

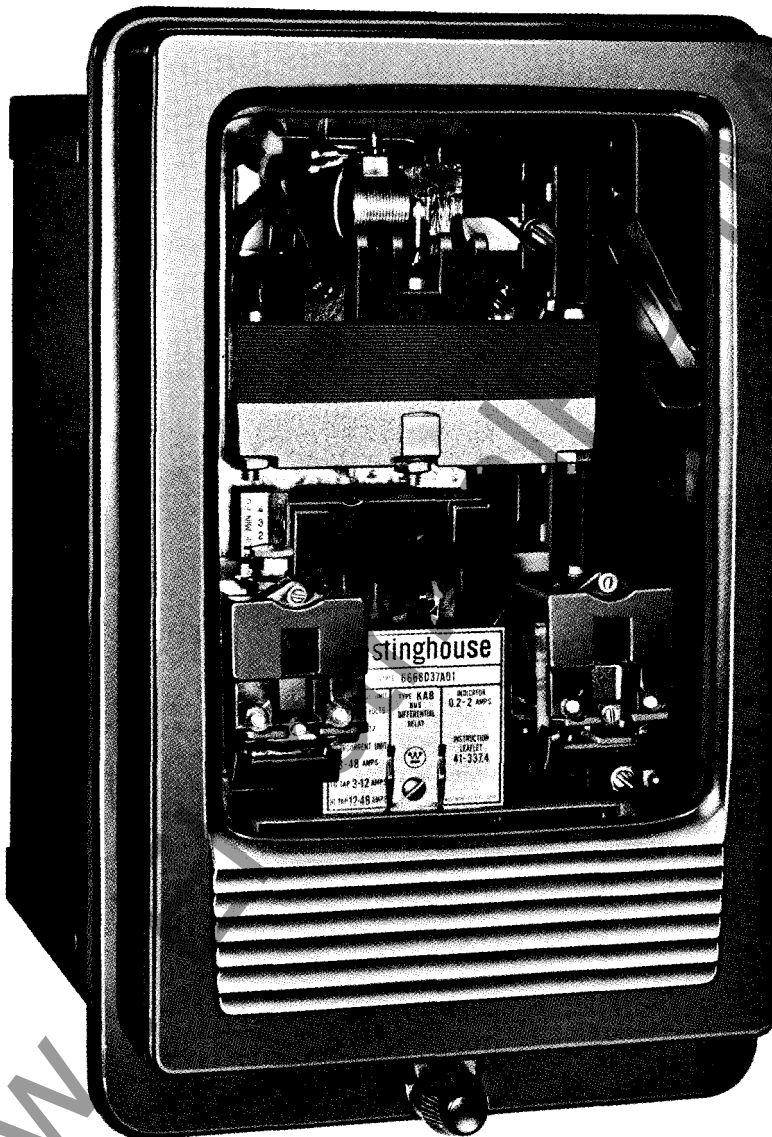

April, 1977
Supersedes DB 41-340, pages 1-4,
dated January, 1974
Mailed to: E, D, C/2015/DB

Device Number 87

Type KAB High Impedance Bus Differential Relay



Application

The type KAB relay is a high-impedance, instantaneous relay for bus differential protection where bushing-type current transformers are in use. An optional low impedance, instantaneous overcurrent unit may be connected in series with the varistor to provide a redundant trip output during moderate and severe fault conditions.

The KAB relay may also be applied in metal clad equipment where current transformers having toroidally wound cores and completely distributed windings are utilized.

Features

The KAB relay, enclosed in the standard Westinghouse Flexitest case, offers several important functional and design advantages:

- The operate time of the voltage unit at two times pick-up is 35 ms. Figure 4 illustrates the results of staged faults. It shows the KAB relay will operate at 1.5 cycles.
- The KAB is supplied in an FT-21 case requiring only $10\frac{7}{16}$ " x $6\frac{3}{8}$ " of panel space.
- The tuned circuit of the KAB voltage unit will remain stable regardless of the change in relay setting. It is inherently immune to dc offset.
- Individual parts of the tuned circuit are available allowing a simple, inexpensive approach to servicing the relay and purchasing replacement parts.
- The KAB design offers the option to omit the 87H overcurrent unit at a reduced price without affecting the operating speed.

Application Considerations

The type KAB relay can be applied for bus protection in most cases where bushing type ct's are in use, and in metal-clad equipment where ct's with toroidally wound cores have their windings completely distributed are employed. Fig. 2 shows the external connection.

The following points should be considered or should be known on any proposed type KAB relay application:

1. All ct's in the bus differential circuit should have the same ratio, and should be operated on their full tap. If tap connection cannot be avoided, the winding section between the

taps being used must be fully distributed and the high voltage which may appear at the full tap terminal due to the auto-transformer action should be checked.

2. The leakage impedance of the ct's which are to be used should be low.
3. The use of the auxiliary ct's is not recommended. If this cannot be avoided the additional impedance from the auxiliary ct's and the high voltage which is transformed by the auxiliary ct's should be checked.
4. The best location for the junction points is equidistant from all ct's.
5. The lead resistance from the junction points to the relay terminals is not critical.
6. A lockout relay contact is recommended to short circuit the varistor following the relay operation in order to prevent the varistor from overheating.

It is recommended that the 86B contact be wired between terminals 9 and 6 to short out the varistor only. Following 86B operation the IT unit is inserted in the differential circuit as a straight overcurrent function allowing for the possibility of using the KAB to energize a breaker failure initiating relay, 62Z, as shown in Fig. 2.

7. To insure a substantial margin of operation on internal faults, the V-unit should not be set higher than the knee voltage, V_k , value of the poorest ct which is connected to the relay.

The knee voltage is defined as the intersection of the extension of the two straight line portions of the saturation curve, ordinate and abscissa must be same scale for each decade.

8. The maximum number of circuits which can be connected to the relay or the minimum

internal fault current required to operate the relay can be estimated from the following equation.

$$I_{min.} = (X I_e + I_R + I_V) N$$

where $I_{min.}$ = minimum internal fault current, RMS.

I_e = ct secondary excitation current at a voltage equal to the setting value of V-unit.

I_R = Current in V-unit at setting voltage V_R (i.e. $I_R = V_R/2600$)

I_V = Current in varistor circuit at a voltage equal to the setting value of V-unit.

N = ct turn's ratio.

X = Number of circuits connected to the bus.

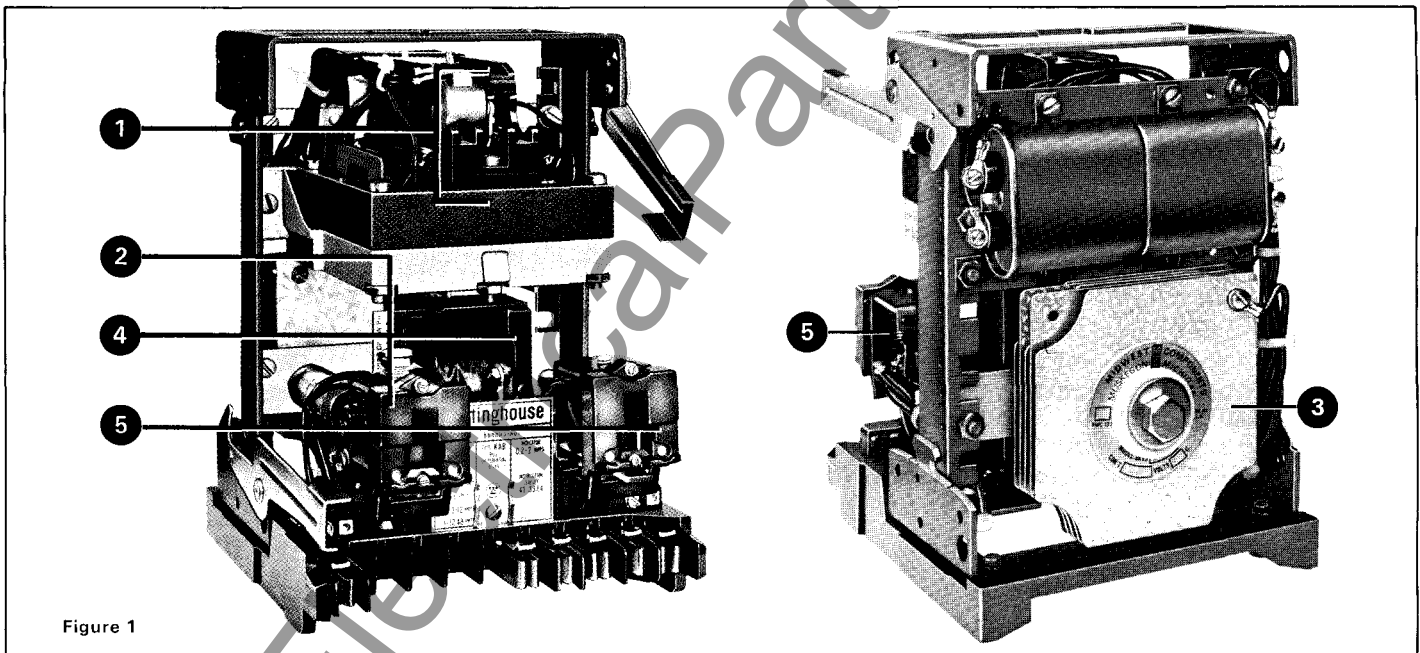

Figure 1

Construction

The KAB relay consists of a high-speed overvoltage cylinder unit (V), a high-speed overcurrent unit (IT), a voltage-limiting suppressor (Varistor), an adjustable reactor and capacitors for completing a tuned circuit, and an indicating contactor switch.

- ① The Overvoltage Cylinder Unit (V) is a product induction cylinder operated by the interaction between the polarizing and operating circuit flux. Its speed of operation at twice pickup is approximately 35 ms (2 cycles); its range of pickup is 75-300 V; or 100-400 V. The pickup is obtained by adjusting the spring windup using adjuster tool style

#774B180G01. Pickup can be changed while relay is in the case.

- ② The Overcurrent Unit (IT) is a small ac operated, clapper-type device with a pickup range of 3 to 48 amperes. The scale plate is calibrated in multiples of minimum pickup: pickup is within ± 10 percent of the setting

Pickup range may be adjusted via a core screw accessible from the top of the unit, and High and Low taps on the coil. The Low tap permits adjustment over a 3 to 12 ampere range; the High tap allows a 12 to 48 ampere range.

- ③ The Varistor is a non-linear voltage dependent resistor.
- ④ The adjustable reactor is an air-gap type having two iron screws which are used at the factory to tune the circuit for maximum current at rated frequency. This feature allows retuning of the circuit in the event other parts of the circuit are replaced.
- ⑤ The Indicating Contactor Switch (ICS) – a small, dc-operated clapper device – drops a target when the relay is operated.



com

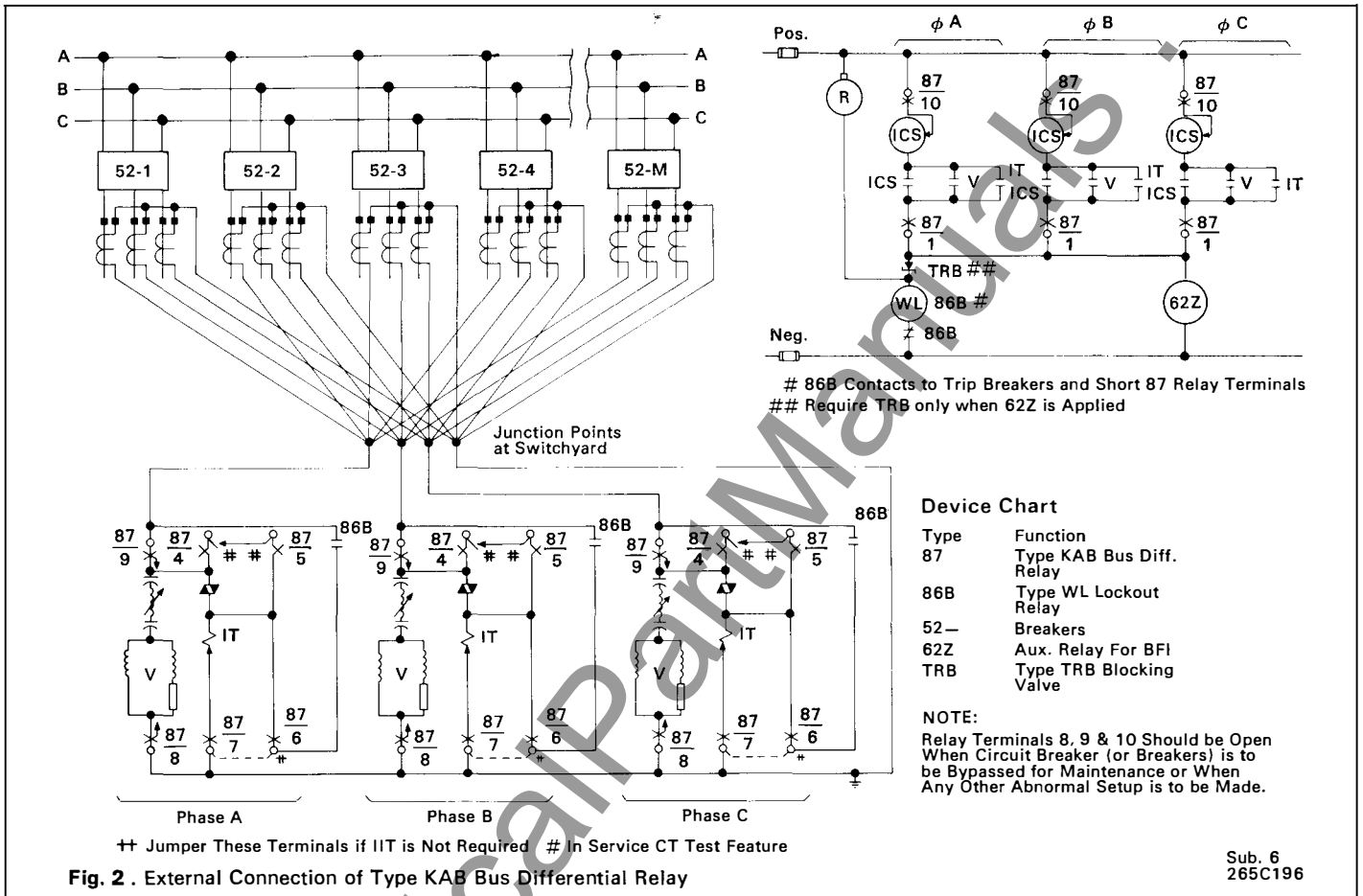

No setting is required for relays with a 1.0 ampere unit. For relays with a 0.2/2.0 ampere unit, connect the lead located in front of the tap block to the desired setting by means of the connecting screw. When the relay energizes a 125 - or 250 - volt dc type WL relay switch, or equivalent, use the 0.2 ampere tap; for 48-volt dc applications set the unit in a tap 2 and use a Type WL relay with a S#304C209G01 coil, or equivalent.

Operation

The relay is connected as shown in external connection Figure 2. For normal operation the voltage at the relay terminals is approximately zero. In the case of an external fault, the voltage at the relay terminals still remains approximately zero if both the source ct's and the faulted ct's are not saturated.

However, during severe external faults the faulted ct may saturate and no voltage or current can be developed from its secondary winding. The source ct's would then have to force their currents through their own windings and through the winding and leads of the faulted ct. In this case a voltage would appear across the junction point equal to the total secondary currents of the source ct's multiplied by the resistance of the faulted ct secondary winding plus its leads to the junction

point. The relay is usually set to operate at some voltage higher than the anticipated voltage expected for this condition. This fault voltage will be lower than the calculated voltage since the faulted ct will always produce some voltage and also the source ct will tend to saturate. The dc offset component of this voltage does not affect the relay operation by reason of the series tuned circuit as well as the insensitivity of the voltage unit to dc.

In the case of an internal fault, the feeder ct's impedances, neglecting the load current, are equal to the magnetizing impedance which is high. Since the relay is high impedance, this makes a high impedance secondary burden to the source ct's, a high voltage will appear at the relay terminals and will be well above the pickup setting.

During severe internal faults the source ct will saturate to limit the RMS value of secondary voltage. However, the peak voltages of the wave form could be quite high and overstress the insulation. A varistor is connected internally to reduce this voltage.

The overvoltage unit is a high speed device and will operate in 2 cycles at twice pickup using a sine wave test voltage. Under fault condition, the crest voltage is rather high, the

operating speed of the V-unit would be faster, Figure 5 shows the operating speed of 1.5 cycles from the typical staged faults. However, an overcurrent unit is provided which may be connected in series with the varistor and will operate in 1 cycle on current flow during severe internal faults when the varistor conducts current to limit the secondary voltage. The application of the overcurrent unit has no effect on the operating speed of the voltage unit.

A high impedance bus differential relay will be subjected to high continuous voltage and will result in damage if any one ct is either open circuited or reversed polarity connection. The KAB relay with "in service ct check" feature, as shown in Fig. 3, will solve this problem. Before putting the relay into service, close all switch handles except terminal 4 and 9. This shunts the high impedance elements, the varistor and the voltage unit, and prevents over-voltage. An ammeter can be inserted to the current test jack at terminal 9. A reading equal to one ct secondary current indicates an open ct connection; a reading equal to twice the ct secondary current indicates a reverse ct connection. The misconnected ct can be identified by shorting and removing each ct in turn from the junction points.

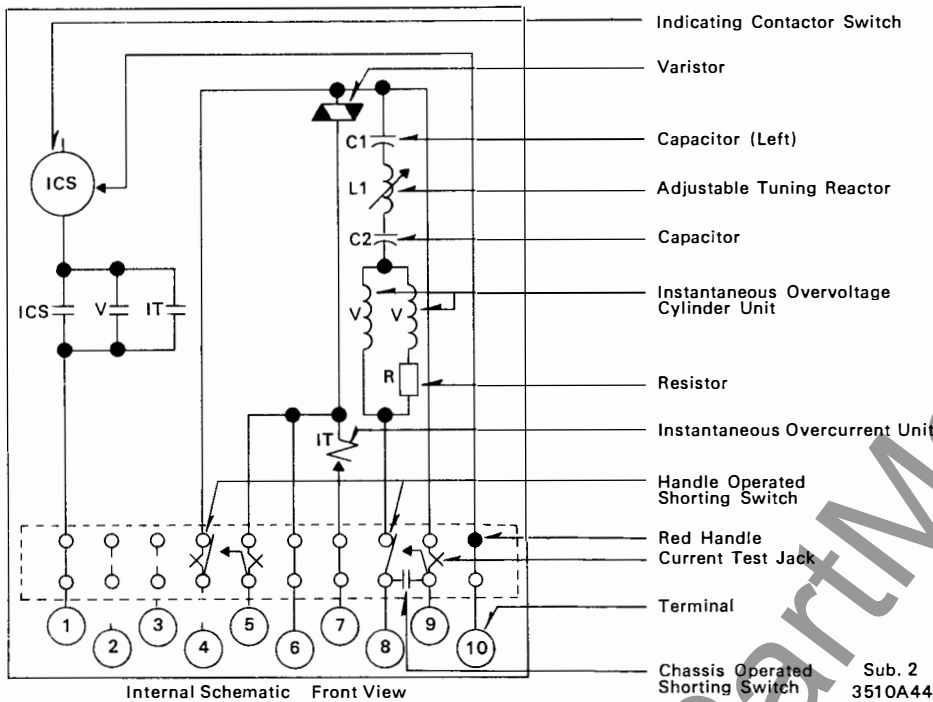

Fig. 3 Relay Type KAB Bus Differential with in Service CT Check Feature.

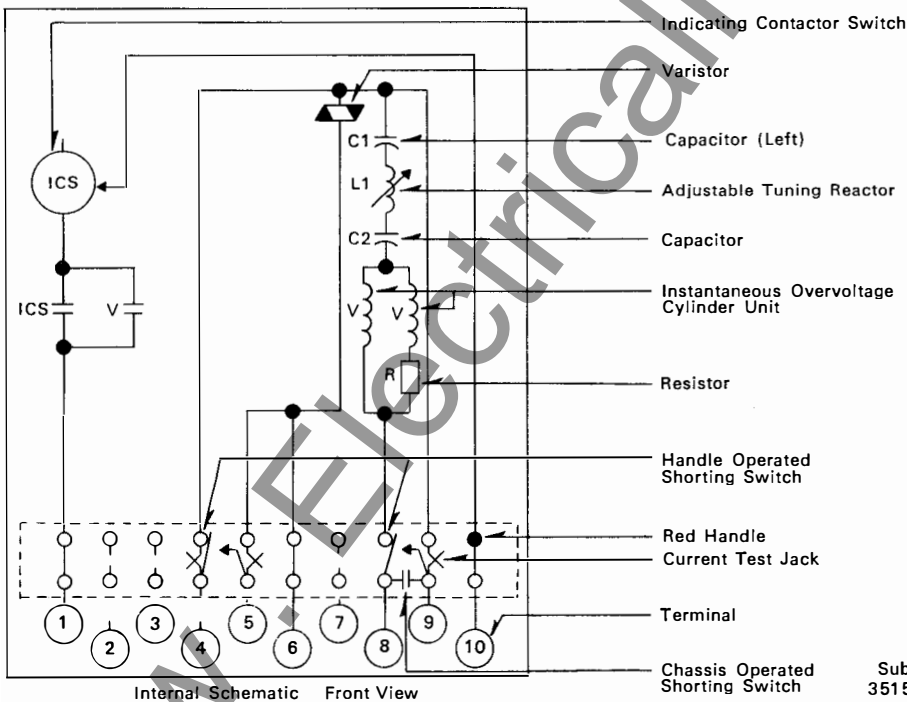

Fig. 4 Relay Type KAB Bus Differential Without IT Unit with in Service CT Check Feature.

Ratings 50 and 60 Hertz Relays

Device	Continuous	
Range	75-300V	100-400V
Overvoltage Unit (V)	250 volts ac 300 volts ac (15 seconds)	250 volts ac 400 volts ac (15 seconds)
Varistor	200 volts ac	200 volts ac
Overcurrent Unit (IT)		
Lo Range	2.5 Amps 100 Amps (1 second)	
Hi Range	10 Amps 200 Amps (1 Second)	
Indicating Contactor Switch (ICS)		
1.0 Amp Rating	5.0 Amps 140 Amps (1 second)	
0.2/2.0 Amp Rating	0.4 Amps 11.5 Amps (1 second)	
0.2 Amp tap	3.2 Amps 88 Amps (1 second)	
2.0 Amp tap		
Varistor	200 Volts ac	

Trip Circuit

The overvoltage unit will close 30 A at 250 Vdc. The seal-in contacts of the ICS will carry this current long enough to trip a circuit breaker.

The overcurrent unit contacts will also close 30 A at 250 Vdc and will carry this current long enough to trip a breaker.

Burden

The relay burden is approximately 2600 ohms in the tuned circuit. However, this burden is not seen by any of the ct's during normal operation or during an external fault. During an internal fault the source ct sees a burden composed of the 2600 ohms in parallel with the Varistor resistance plus the parallel impedance of the unloaded feeder ct's.

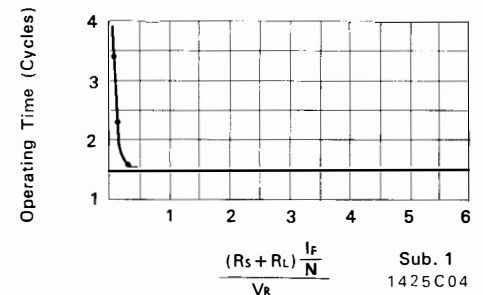

Fig. 5 KAB Relay-Typical Operating Time.

Further Information

Specifications & Ordering Information - TD 41-020

Prices - PL 41-020

Instructions, Setting, Maintenance, etc. - IL 41-337.4

FT-21 Case Dimensions - DB 41-075

Other Westinghouse Protective Relays - Selector Guide 41-000 A, B, C