

Instructions for the Application of Digitrip RMS 500, 600, 700 & 800 Retrofit Kits on Power Circuit Breakers

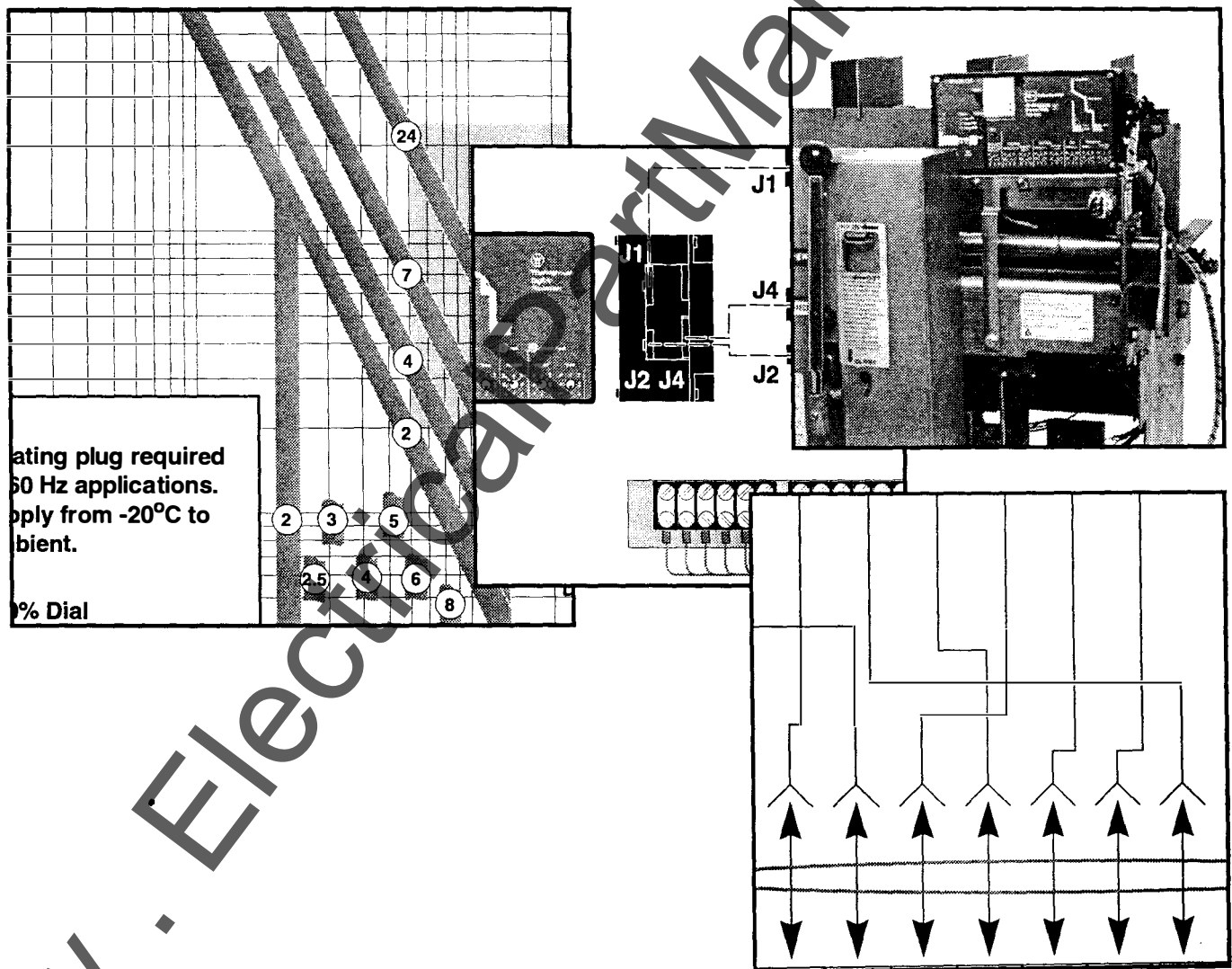

Cutler-Hammer

Five Parkway Center
Pittsburgh, PA 15220

Supersedes AD 33-855 – September, 1993



Table of Contents

Section 1 General Information and Safety Precautions	1	Section 8 Testing, Checkout, and Settings	25
1-1. Safety Precautions		8-1. Dielectric and Meggar Testing	
1-2. Introduction		8-2. Testing the Digitrip RMS Trip System	
1-3. Warranty Disclaimer and Liability Limitation		8-3. Digitrip RMS Self Testing	
Section 2 Digitrip RMS Retrofit Kits, Rating Plugs, and Accessories	3	8-3.1 Recommended Test Points for Digitrip RMS Units Using the Self Test Function	
2-1. Digitrip RMS Retrofit Kits		8-4. Ampptector Test Kit	
2-2. Retrofit Kit Installation Requirements		8-4.1 Recommended Test Points for Digitrip RMS Units Using Cutler-Hammer Ampptector Test Set	
2-3. Digitrip RMS Retrofit Kit Accessories		8-5. Primary Injection Testing	
Section 3 The Digitrip RMS Trip System	6	8-5.1 Recommended Test Points for Digitrip RMS Units Using Primary Injection Tester	
3-1. Digitrip RMS Overcurrent Protection		8-6. Circuit Breaker Checkout and Bench Test	
3-2. Current Sensors (& Sensor Wiring Harness)		8-7. Setting Digitrip RMS IMPACC Address (Digitrip RMS Models 700 & 800 Only)	
3-3. Auxiliary CT Module (& Auxiliary CT Harness)		8-8. Identification of Trip Unit, Breaker, and Switchgear Cell	
3-4. Digitrip RMS/R Trip Unit (& Power Relay Module, ATR)		Section 9 Operation	34
3-5. Making Current Release (Discriminator)		9-1. Breaker Insertion and Removal	
3-6. Digitrip RMS Direct Trip Actuator (DTA) (& Auxiliary Switch Kit)		9-2. Electrical Closing Via IMPACC	
3-7. Digitrip RMS/R Rating Plug and Battery		9-3. In the Event of a Trip	
3-8. External Harness with Plug		9-4. Resetting the Trip Unit After a Trip	
3-9. Potential Transformer Module (PTM)		9-5. Removing the Breaker From the CONNECT Position	
3-10. Cell Harness Assembly		Section 10 Digitrip RMS Retrofit Kit Switchgear Assembly Applications	38
Section 4 Digitrip RMS 500 Basic Retrofit Kits	14	10-1. Zone Interlocking	
(Without Zone Interlocking)		10-2. Remote Alarm Signals and the Power Relay Modules (ATR)	
4-1. Digitrip RMS 500 Basic Retrofit Kit Selection and Content		10-3. Communications and IMPACC	
4-2. Digitrip RMS 500 Basic Retrofit Kit Features		Section 11 Warranty and Service Information	45
Section 5 Digitrip RMS 500 Retrofit Kits	16	11-1. Preventative Maintenance Program	
(With Zone Interlocking)		11-2. Breaker Maintenance	
5-1. Digitrip RMS 500 Retrofit Kit (With Zone Interlocking) Selection and Content		11-3. Warranty Procedure	
5-2. Digitrip RMS 500 Retrofit Kit (With Zone Interlocking) Features		11-4. Digitrip RMS Trip Unit Warranty	
Section 6 Digitrip RMS 600 Retrofit Kits	18	Section 12 Detailed Wiring Information	46
6-1. Digitrip RMS 600 Retrofit Kit Selection and Content		(Common to all Digitrip RMS/R Kits)	
6-2. Digitrip RMS 600 Retrofit Kit Features		12-1. Sensor Harness and CT Harness Wiring	
Section 7 Digitrip RMS 700 & 800 Retrofit Kits	21	12-2. Auxiliary CT Harness Wiring	
7-1. Digitrip RMS 700 & 800 Retrofit Kit Selection and Content		12-3. Auxiliary CT Module Wiring	
7-2. Digitrip RMS 700 & 800 Retrofit Kit Features		Section 13 References	
7-3. Power Flow Convention		Section 14 Explanation of Time-Current Curves	51
7-4. IMPACC Communications Wiring Checkout		14-1. Explanation of the Time-Current Curves	
		14-2. Explanation of Time-Current Tables	
		14-3. An Example of Using Time-Current Tables (LSI)	
		14-5. Curve Plotting Aids (LSI)	

List of Figures and Tables

Section 2 Digitrip RMS Retrofit Kits, Rating Plugs, and Accessories

- Table 2-1 Digitrip Rating Plugs (50 and 60 Hz) and Their Coordination with Sensor Connections
- Table 2-2 Digitrip RMS Retrofit Kit Accessories

Section 3 The Digitrip RMS/R Trip System

- Figure 3-1 Digitrip Retrofit System
- Figure 3-2 Digitrip RMS/R Long Time/Instantaneous Time-Current Curve (LI)
- Figure 3-3 Digitrip RMS/R Long Time/Short Time Time-Current Curve (LS)
- Figure 3-4 Digitrip RMS/R Ground Fault Protection Time-Current Curve (G)
- Figure 3-5 Digitrip RMS Direct Trip Actuator (DTA)

Section 4 Digitrip RMS 500 Basic Retrofit Kits (Without Zone Interlocking)

- Figure 4-1 Digitrip RMS/R 500 Basic External Harness
- Figure 4-2 Digitrip RMS/R 500 Basic Wiring

Section 5 Digitrip RMS 500 Retrofit Kits (With Zone Interlocking)

- Figure 5-1 Digitrip RMS/R 500 External Harness
- Figure 5-2 Digitrip RMS/R 500 Cell Harness
- Figure 5-3 Digitrip RMS/R 500 Wiring

Section 6 Digitrip RMS 600 Retrofit Kits

- Figure 6-1 Digitrip RMS/R 600 External Harness
- Figure 6-2 Digitrip RMS/R 600 Cell Harness
- Figure 6-3 Digitrip RMS/R 600 Wiring

Section 7 Digitrip RMS 700 & 800 Retrofit Kits

- Figure 7-1 Digitrip RMS/R 700 & 800 External Harness
- Figure 7-2 Digitrip RMS/R 700 & 800 Cell Harness
- Figure 7-3 Digitrip RMS/R 700 & 800 Wiring
- Figure 7-4 Digitrip RMS/R 700 & 800 PT Module

Section 8 Testing Retrofitted Breakers

- Figure 8-1 Pick-up Test and Time Test
- Tables 8-1 to 8-3

Section 9 Operation

- Table 9-1 and Table 9-2

Section 10 Digitrip RMS Retrofit Kit Switchgear Assembly Applications

- Figures 10-1 to 10-7

Section 12 Detailed Wiring Information

- (Common to all Digitrip RMS/R Kits)
- Figures 12-1 to 12-6

Section 14 Explanation of Time-Current Curves

- Figure 14-1 Time-Current Curves
- Table 14-1 Long Delay Pickup Currents
- Table 14-2 Short Delay and Instantaneous Pickup Currents
- Table 14-3 Min and Max Trip Times for Long Delay Band
- Table 14-4 Min and Max Trip Times for Short Delay and Instantaneous Band
- Table 14-5 Long Delay Time Values
- Table 14-6 Short Delay Time Values (Flat)
- Table 14-7 Short Delay Time Values (I^2t)

Section 1

General Information and Safety Precautions

1-1. Safety Precautions

The warnings included as part of the procedural steps in this manual are for personnel safety and protection of equipment from damage. An example of a typical warning is shown below to familiarize personnel with the style of presentation. In addition, the following warning applies throughout this manual. It should be read and understood before proceeding.

 **WARNING**

POWER CIRCUIT BREAKERS ARE EQUIPPED WITH HIGH SPEED, HIGH ENERGY OPERATING MECHANISMS. THE BREAKERS AND THEIR ENCLOSURES ARE DESIGNED WITH SEVERAL BUILT-IN INTERLOCKS AND SAFETY FEATURES INTENDED TO PROVIDE SAFE AND PROPER OPERATING SEQUENCES. TO PROVIDE MAXIMUM PROTECTION FOR PERSONNEL ASSOCIATED WITH THE INSTALLATION, OPERATION, AND MAINTENANCE OF THESE BREAKERS, THE FOLLOWING PRACTICES MUST BE FOLLOWED. FAILURE TO FOLLOW THESE PRACTICES MAY RESULT IN DEATH, PERSONAL INJURY, OR PROPERTY DAMAGE.

- Only qualified persons, as defined in the National Electric Code, who are familiar with the installation and maintenance of power circuit breakers and their associated switchgear assemblies should perform any work associated with these breakers.
- Completely read and understand all instructions before attempting any installation, operation, maintenance, or modification of these breakers.
- **Always turn off and lock out the power source feeding the breaker prior to attempting any installation, maintenance, or modification of the breaker. Do not use the circuit breaker as the sole means for isolating a high voltage circuit. Follow all lockout and tagging rules of the National Electric Code and all other applicable codes, regulations, and work rules.**

- Do not work on a closed breaker or a breaker with the closing springs charged. Trip (open) the breaker and be sure the stored energy springs are discharged before performing any work. The breaker may trip open or the charging springs may discharge, causing crushing or cutting injuries.
- For drawout breakers, trip (open), and then remove the breaker to a well-lit work area before beginning work.
- Do not perform any maintenance: including breaker charging, closing, tripping, or any other function which could cause significant movement of the breaker while it is on the extension rails. Doing so may cause the breaker to slip from the rails and fall, potentially causing severe personal injury to those in the vicinity.
- **Do not leave the breaker in an intermediate position in the switchgear cell. Always leave it in the connected, disconnected, or (optional) test position. Failure to do so could lead to improper positioning of the breaker and flashover, causing death, serious personal injury, and/or property damage.**
- Do not defeat any safety interlock. Such interlocks are intended to protect personnel and equipment from damage due to flashover and exposed contacts. Defeating an interlock could lead to death, severe personal injury, and / or property damage.

1-2. Introduction

This application data is provided as a guide, for authorized and qualified personnel only, in the selection and application of Digitrip RMS Retrofit Kits on Power Circuit Breakers.

The information, recommendations, descriptions and safety notations in this document are based on Cutler-Hammer's experience and judgement with respect to retrofitting Power Circuit Breakers. All possible contingencies which may arise during installation, operation or maintenance, and all details and variations of this equipment do not purport to be covered by this document. If further information is desired by the purchaser regarding a particular installation, operation or maintenance of his particular equipment, the local Cutler-Hammer representative should be contacted or phone 1-800-937-5487.

1-3. Warranty Disclaimer and Liability Limitation

The instructions for installation, testing, maintenance, or repair herein are provided for the use of the product in general commercial applications and may not be appropriate for use in nuclear applications. Additional instructions may be available upon specific request to replace, amend, or supplement these instructions to qualify them for use with the product in safety-related applications in a nuclear facility.

The information, recommendations, descriptions, and safety notations in this document are based on Cutler-Hammer's experience and judgement with respect to retrofitting of power breakers. This information should not be considered to be all inclusive or covering all contingencies. If further information is required, Cutler-Hammer should be consulted.

NO WARRANTIES, EXPRESSED OR IMPLIED, INCLUDING WARRANTIES OF FITNESS FOR A PARTICULAR PURPOSE OR MERCHANTABILITY, OR WARRANTIES ARISING FROM COURSE OF DEALING OR USAGE OF TRADE, ARE MADE REGARDING THE INFORMATION, RECOMMENDATIONS AND DESCRIPTIONS CONTAINED HEREIN. In no event will Cutler-Hammer be responsible to the user in contract, in tort (including negligence), strict liability or otherwise, for any special, indirect, incidental, or consequential damage or loss whatsoever, including but not limited to damage to or loss of use of equipment, plant or power system, cost of capital, loss of profits or revenues, cost of replacement power, additional expenses in the use of existing power facilities, or claims against the user by its customers resulting from the use of the information, recommendations, and descriptions contained herein.

Section 2

Digitrip RMS Retrofit Kits, Rating Plugs, and Accessories

2-1. Digitrip RMS Retrofit Kits

Cutler-Hammer Digitrip RMS Retrofit Kits are available for many types of major manufacturers of Power Circuit Breakers. The Digitrip RMS Retrofit Kits are structured according to the Digitrip RMS/R Trip Unit and the specific overcurrent protective features provided.

The product line begins with the Digitrip RMS 500 Basic Retrofit Kit series. True RMS sensing, basic overcurrent protection, and self-testing features are standard. The overcurrent protection provided is determined by the selected Long Time (L), Short Time (S), Instantaneous (I), and Ground Fault (G) Trip Functions.

The balance of the Retrofit Kits listed (Digitrip RMS 500, 600, 700 & 800 series), add increasing levels of features to those of the RMS 500 Basic Retrofit Kits and to each other. The features include Zone Interlocking, Digital Alphanumeric Displays, Remote Alarm Signals, IMPACC Communications, and Energy Monitoring Capability.

Additional information on the features and content of each Digitrip RMS Retrofit Kit is provided in Sections 4 through 7 of this Application Guide.

2-2. Retrofit Kit Installation Requirements

Digitrip RMS Retrofit Kits can be applied to many types of Power Circuit Breakers, provided the Breakers are used on 50 or 60 Hz AC distribution systems. Retrofits for fixed-mounted or nondraw-out Breakers should be referred to Cutler-Hammer for evaluation.

WARNING

THE DESIGN AND CONTENT OF THE RETROFIT KIT IS BASED ON THE FOLLOWING CONDITIONS, WHICH MUST BE ADDRESSED BY THE RETROFIT KIT PURCHASER, PRIOR TO INSTALLATION. FAILURE TO ADDRESS THESE CONDITIONS COULD RESULT IN FAILURE OF THE EQUIPMENT TO OPERATE PROPERLY, PERMANENT EQUIPMENT DAMAGE, AND IN SOME INSTANCES, PERSONAL INJURY OR DEATH:

- 1. The Breaker must be in good mechanical and electrical operating condition.** Breakers that are not in good operating condition should be repaired, reconditioned, or refurbished in addition to being retrofitted. Refer to Section 11 for general guidelines on Breaker preventative maintenance.
- 2. Rating Plug selection.** One 60 Hz Rating Plug is normally provided, which does not exceed the Breakers' maximum continuous current frame rating. If an alternate Rating Plug is required for the Breaker retrofitted, it can be ordered separately or as part of the kit. Table 2-1 provides a complete listing of all Rating Plugs, including those for 50 Hz application. Rating Plugs must coordinate with the Breaker Sensor Tap being used. Together they determine the Breaker I_n (Continuous Current) Rating. Refer to Catalog 26-000 for Retrofit Kit ordering information.
- 3. Retrofit Kits shown with Ground Fault (G) Protection assume a 3-phase 3-wire grounded system.** If the retrofit is for a 4-wire grounded system, the customer must specify the fourth sensor or when ordering the kit. Also, provisions must be made on the Breaker to bring the fourth sensor wiring through the Breaker secondary contacts. Secondary contacts and brackets, etc. are not included in the content of the kits.
- 4. Digitrip RMS 600, 700 & 800 Retrofit Kits require an external (customer supplied) 120 Vac source to power the Trip Unit information functions and Alphanumeric Digital Displays, as applicable.**

Table 2-1
Digitrip Rating Plugs (50 and 60 Hz) and Their Coordination with Sensor Connections

Sensor Rating	60 Hz Rating Plug Catalog Number & I_n Rating	50 Hz Rating Plug Catalog Number & I_n Rating
200:5	PR6A02A010 100 Amp	PR5A02A010 100 Amp
	PR6A02A020 200 Amp	PR5A02A020 200 Amp
300:5	PR6A03A020 200 Amp	PR5A03A020 200 Amp
	PR6A03A025 250 Amp	PR5A03A025 250 Amp
	PR6A03A030 300 Amp	PR5A03A030 300 Amp
400:5	PR6A04A020 200 Amp	PR5A04A020 200 Amp
	PR6A04A025 250 Amp	PR5A04A025 250 Amp
	PR6A04A030 300 Amp	PR5A04A030 300 Amp
	PR6A04A040 400 Amp	PR5A04A040 400 Amp
600:5	PR6A06A030 300 Amp	PR5A06A030 300 Amp
	PR6A06A040 400 Amp	PR5A06A040 400 Amp
	PR6A06A060 600 Amp	PR5A06A060 600 Amp
800:5	PR6A08A040 400 Amp	PR5A08A040 400 Amp
	PR6A08A060 600 Amp	PR5A08A060 600 Amp
	PR6A08A080 800 Amp	PR5A08A080 800 Amp
1200:5	PR6A12A060 600 Amp	PR5A12A060 600 Amp
	PR6A12A080 800 Amp	PR5A12A080 800 Amp
	PR6A12A100 1000 Amp	PR5A12A100 1000 Amp
	PR6A12A120 1200 Amp	PR5A12A120 1200 Amp
1600:5	PR6A16A080 800 Amp	PR5A16A080 800 Amp
	PR6A16A100 1000 Amp	PR5A16A100 1000 Amp
	PR6A16A120 1200 Amp	PR5A16A120 1200 Amp
	PR6A16A160 1600 Amp	PR5A16A160 1600 Amp
2000:5	PR6A20A100 1000 Amp	PR5A20A100 1000 Amp
	PR6A20A120 1200 Amp	PR5A20A120 1200 Amp
	PR6A20A160 1600 Amp	PR5A20A160 1600 Amp
	PR6A20A200 2000 Amp	PR5A20A200 2000 Amp
3000:5	PR6A30A160 1600 Amp	PR5A30A160 1600 Amp
	PR6A30A200 2000 Amp	PR5A30A200 2000 Amp
	PR6A30A250 2500 Amp	PR5A30A250 2500 Amp
	PR6A30A300 3000 Amp	PR5A30A300 3000 Amp
4000:5	PR6A40A200 1000 Amp	PR5A40A200 2000 Amp
	PR6A40A250 2500 Amp	PR5A40A250 2500 Amp
	PR6A40A300 3000 Amp	PR5A40A300 3000 Amp
	PR6A40A320 3200 Amp	PR5A40A320 3200 Amp
	PR6A40A400 4000 Amp	PR5A40A400 4000 Amp

Notes:

1. Sensor Tap rating connected must correspond with the Rating Plug shown.
2. Breaker current rating shown is adjustable down to 50% of the value listed with Digitrip RMS/R Long Delay Pickup Setting.

2-3. Digitrip RMS Retrofit Kit Accessories

Table 2-2 provides a listing of optional accessories that are useful in the installation, maintenance, and

operation of your Breaker equipped with a Digitrip RMS Retrofit Kit.

Table 2-2
Digitrip RMS Retrofit Kit Accessories

Accessory Description	Accessory Style or Catalog Number	Function
Auxiliary Power Module (APM)	PRTAAPM	Powers Digitrip RMS Trip Unit for testing
Amptector Test Kit	140D481G02RR or G03	Tests Digitrip RMS Trip Unit. Requires Adapter Harness.
Amptector Test Kit Adapter Harness*	6503C53G01 (Type1) or 6503C54G01 (Type2) and 6503C55G01 (Breaker Mounted Test Plug)	Tests Digitrip RMS Trip Unit with Amptector Test Kit.
Zone Interlock Shorting Plug	6502C83G01	Plugs into RMS / R Trip Unit Plug J2. Shorts Out G_{IN} to G_{OUT} and S_{IN} to S_{OUT} during Trip Unit testing.
Lithium Battery 3.0 Volt	Model CR 1/3N, Varta Batteries, Inc. , 150 Clarabrook Road, Elmsford, NY 10523 Duracell Model DL 1/3N, South Broadway, Tangtown, NY 10591 (914)-591-7000 Model 2L-76BR, Battery Products Div., Union Carbide Corp. Eveready, 39 Old Ridgebury Road Danbury, CT 06817-0001 (203)-794-7548	Powers Digitrip LED Mode of Trip Indicators (Back-up Power).

*See Section 8-4.

Section 3

The Digitrip RMS Trip System

3-1. Digitrip RMS Overcurrent Protection

The Digitrip RMS Retrofit Kit styles covered by this Application Guide are designed to replace the existing Trip System employed on the Breaker selected for retrofitting.

All Digitrip RMS Retrofit Kits provide basic overcurrent protection, which includes a selected combination of Long Time (L), Short Time (S), Instantaneous (I), and Ground Fault Time (G) Delay Trip Functions. Five major components comprise the Digitrip RMS Trip System; the Current Sensors, Auxiliary CT Module, Digitrip Trip Unit, Rating Plug, and the Direct Trip Actuator (DTA). These components are interconnected by use of the various wiring harnesses to make up the Digitrip RMS Trip System. Breaker interface diagrams for Digitrip RMS 500 through 800 are provided in Sections 4 through 7. These diagrams show the major Digitrip RMS components and their interconnections. Wiring diagrams for each of the Wire Harnesses are shown in Section 12.

Figure 3-1 shows the major components of the Digitrip Retrofit System and their interconnections. The following describes the function and operation of each component.

3-2. Current Sensors (& Sensor Wiring Harness)

Three multi-tapped Current Sensors (one per phase) are located at the rear of the Breaker. The sensors pass information to the Auxiliary CT Module and the Trip Unit on the primary current level passing through the Breaker. All the energy required to power the Digitrip RMS Trip System is produced by the Current Sensors.

The Current Sensors are connected to a terminal block strip on the Auxiliary CT Module by the Sensor Wiring Harness. The Current Sensor Tap ratio connected, in concert with the Rating Plug, determines the I_n (Continuous Current) Rating of the Breaker. At rated primary current, the Current Sensors provide 5 ampere nominal current inputs to the Auxiliary CT Module.

3-3. Auxiliary CT Module (& Auxiliary CT Harness)

The Auxiliary CT Module encloses three auxiliary phase Current Transformers, which reduce the 5 ampere nominal inputs from the Current Sensors to the milliampere level required for the Digitrip RMS/R Trip Unit electronics. When Ground Fault (G) protection is selected, a Ground Auxiliary Current Transformer is also provided, which performs the same function.

A 7 point terminal block strip is mounted on the front of the module. Terminals A through G terminate the inputs from the Current Sensors via the Sensor Wiring Harness. Terminals OP and ON connect the Trip Signal Outputs to the Direct Trip Actuator through the Sensor Wiring Harness or DTA Wiring Harness. A 12 point female CT Plug-in Block is mounted on the right hand side of the module, which receives the male plug of the Auxiliary CT Harness. The Auxiliary CT Harness also has a 10 pin black plug, which plugs into the Trip Unit to connect the Auxiliary CT Inputs to the Trip Unit and receives the Trip Unit trip signal outputs.

3-4. Digitrip RMS/R Trip Unit (& Power Relay Module, ATR)

The Digitrip RMS/R (Rms/R Retrofit) Trip Unit, Figure 3-1, is designed to permit flexibility in retrofit applications. It is a physically repackaged version of the original Digitrip RMS Trip Unit that is used on Cutler-Hammer and Westinghouse DS and SPB Breakers. The RMS and RMS/R Trip Units have the same features and options and have identical characteristic curves, adjustments, and electrical performance.

The Digitrip RMS/R Trip Unit is a microprocessor based protective device that provides true RMS sensing means for proper correlation with thermal characteristics on conductors and equipment. Digitrip RMS/R Trip Units are available in four models, RMS/R 500, 600, 700 & 800. These models are available in horizontal or vertical labeling and display orientations.

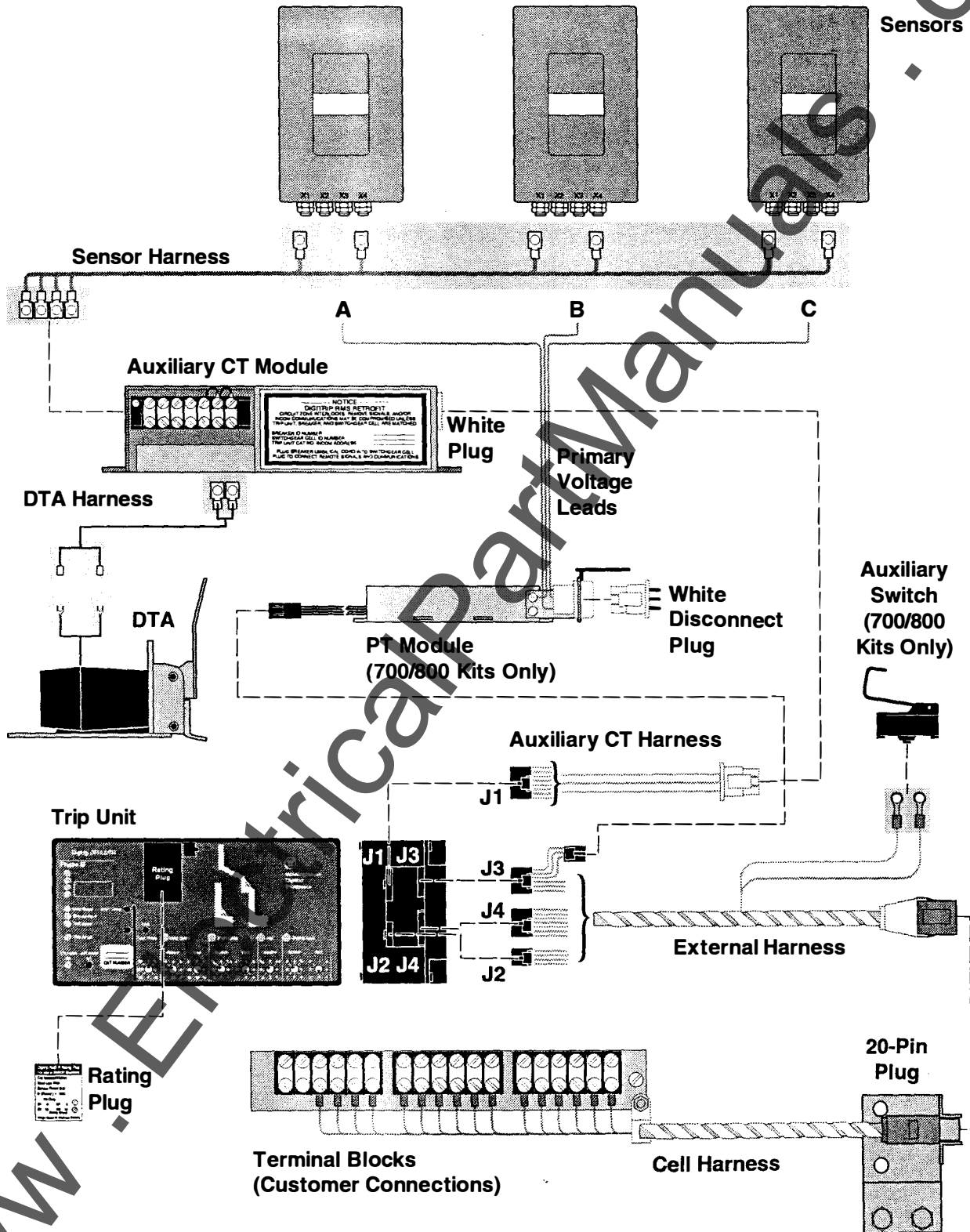

Figure 3-1 Digitrip Retrofit System

The Trip Unit includes a female type receptacle, provided to accept a Rating Plug, which (in concert with the Current Sensors) determines the I_n (Continuous Current) Rating of the Breaker. Adjustable current protective settings are provided for the Long Time (L), Short Time (S), Instantaneous (I), and Ground Fault (G) Trip Functions selected. Short Time (S) and Ground Fault (G) Delays are equipped with an adjustable setting for a flat or an I^2t response. The adjustable settings are step-type, expressed in terms of the I_n (Continuous Current) Rating of the Breaker. LEDs provide Mode of Trip Indications for the L, S, I, and G trip functions. Digitrip RMS/R Trip Units are equipped with multi-pin disconnect plug receptacles, which permit quick connections to the Auxiliary CT Harness and (when supplied) the External Harness.

The Power Relay Module (ATR) is provided in Digitrip RMS/R Trip Unit models 600 through 800 only. The ATR provides hard contact closures for remote indication of the following Trip Unit functions:

- High Load (HL) Alarm: The HL contact closes when the current passing through the Breaker exceeds 85% of the Trip Unit Long Delay Pickup Setting continuously for more than 40 seconds.
- Long Delay (LD) Trip
- Short Circuit (SC) Trip
- Ground Fault (GF) Trip functions
- IMPACC Remote Close (CC1 and CC2) Contact (RMS/R 700 & 800 Trip Units only)

All ATR contacts are rated 1 ampere at 120 Vac or 1 ampere at 28 Vdc. These contacts are generally used for illuminating indicator lights or picking up slave relays local to or remote from the Breaker/Switchgear. A bridge rectifier circuit in the ATR serves to power up (as applicable) the Trip Unit Alphanumeric Display and the INCOM communications logic, when a 120 Vac source is supplied to ATR terminals AC120 and ACCOM.

Digitrip RMS/R Trip Units are equipped with a receptacle to receive the Auxiliary Power Module (APM). The APM is used to supply power to the Trip Unit self-test system during Circuit Breaker testing. Adjustable test settings are provided which enable the unit to be tested with or without tripping the Breaker.

Figures 3-2 through 3-4 provide the published Digitrip RMS Characteristics Curves for Retrofit Breakers. Also provided are the available Trip Unit settings for all trip functions.

3-5. Making Current Release (Discriminator)

When the Digitrip RMS 500 Trip Unit is not equipped with an adjustable instantaneous protection setting, i.e., types LS or LSG, a Making Current Release (or discriminator) circuit is provided. This circuit will prevent the Circuit Breaker from being closed and latched-in on a faulted circuit. The non-adjustable release is pre-set at eleven (11) times the installed Rating Plug ampere rating (I_n).

The Making Current Release is armed only for the first ten (10) cycles following an initial Circuit Breaker closing operation with a load current exceeding approximately 20% of the Circuit Breaker Frame or Sensor Rating. Should the Load Current through the Circuit Breaker drop to a value less than this, the release will re-arm. The release, once armed, will remain armed until the Load Current passing through the Circuit Breaker exceeds approximately 20% for 10 cycles. Any trip operation initiated by the Making Current Release will trip the Circuit Breaker instantaneously.

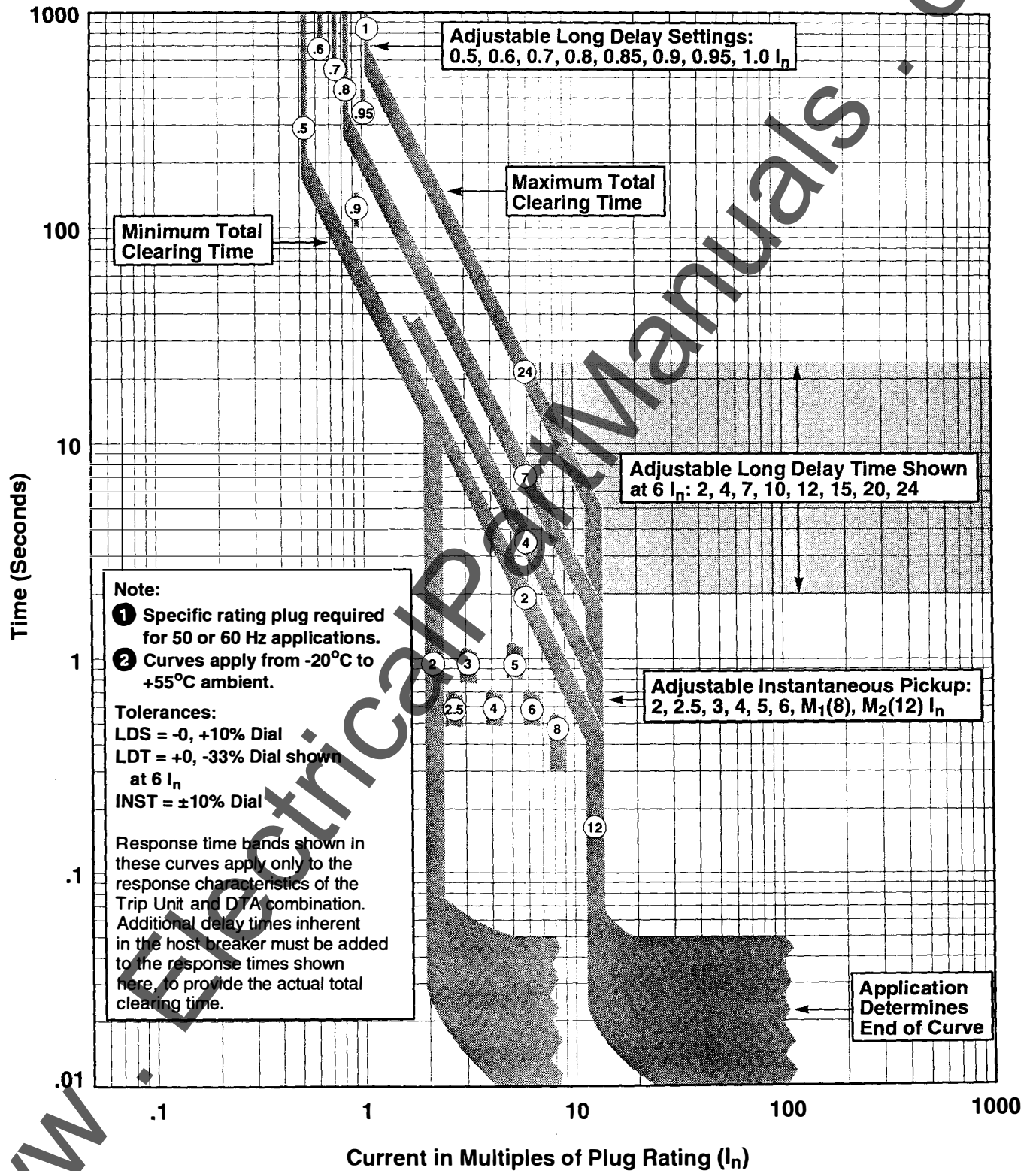

Figure 3-2 Digtrip RMS/R Long Time/Instantaneous Time-Current Curve (LI)

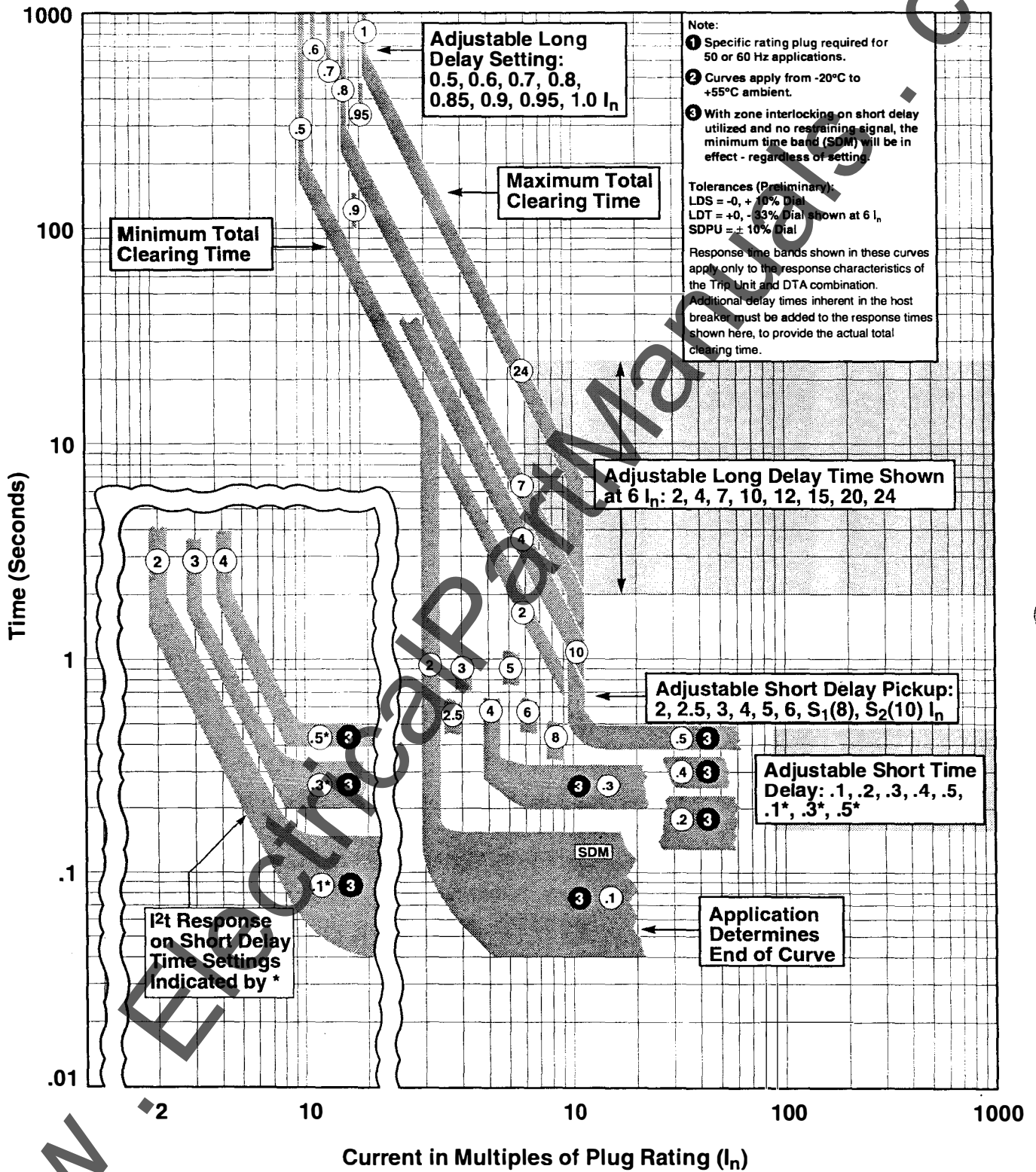

Figure 3-3 Digitrip RMS/R Long Time/Short Time Time-Current Curve (LS)

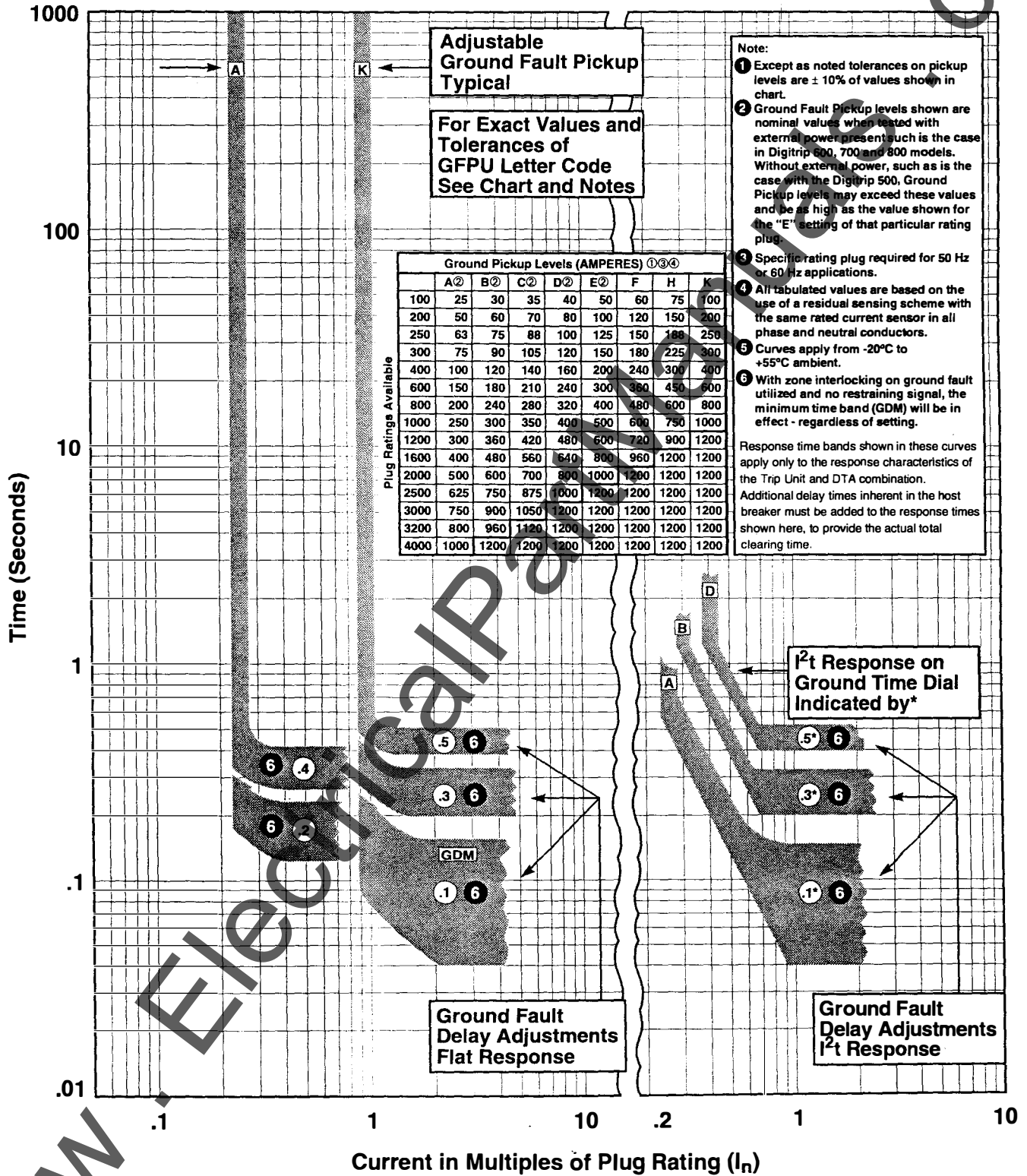

Figure 3-4 Digitrip RMS/R Ground Fault Protection Time-Current Curve (G)

3-6. Digitrip RMS Direct Trip Actuator (DTA) (& Auxiliary Switch Kit) (see Figure 3-5)

The Digitrip RMS Direct Trip Actuator (DTA) receives an electrical trip pulse from the Trip Unit via the Auxiliary CT Module and provides the mechanical trip force to trip the Breaker.

The DTA is made up of a permanent magnet, a disc held by the magnet, a rod acted on by a spring, a means for tripping the Breaker, and a Reset Mechanism for mechanically resetting the Actuator. The magnet cannot pull and reset the disc against the force of the spring acting on the rod, but it can overcome the spring force when the disc is in contact with the magnet pole piece.

A tripping pulse from the Trip Unit counteracts the effect of the permanent magnet, allowing the spring to separate the disc from the magnet pole piece and to actuate the Trip Mechanism. The Trip Mechanism strikes the Breaker Trip Bar and trips the Breaker. As the Breaker opens, the Breaker Mechanism moves the DTA Reset Mechanism, which moves the disc to close the

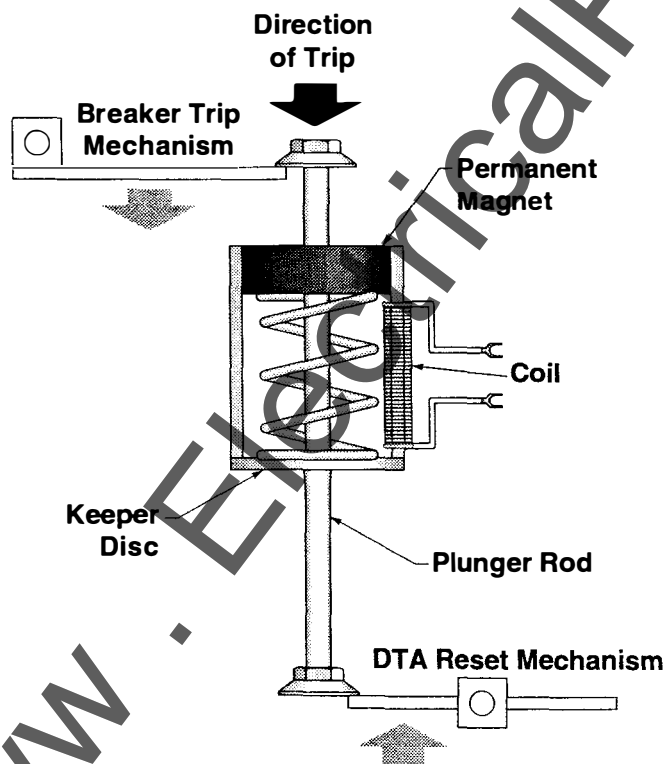

Figure 3-5 Digitrip RMS Direct Trip Actuator (DTA)

air gap between it and the magnet pole piece. The DTA is reset when the disc is held in contact with the magnet pole piece, against the spring force. If the DTA does not reset properly, the Trip Lever will hold the Breaker in the trip free condition and the Breaker will not be able to close.

RMS 700 & 800 Retrofit Kits include an Auxiliary Switch Kit, which usually mounts on or near the DTA. The Auxiliary Switch Kit consists of a microswitch with mounting hardware and brackets. The switch is used to provide the Trip Unit with information on the Breaker position, i.e. open or closed. This status information is passed on through the IMPACC network.

3-7. Digitrip RMS/R Rating Plug and Battery

The Digitrip RMS/R Rating Plug fits into the Digitrip RMS/R Trip Unit and determines the Breaker I_n (Continuous Current) Rating. The Rating Plug must be matched to the installed Current Sensor ratio and the distribution system frequency, i.e. 50 or 60 Hertz. Each Rating Plug has fixed S_1 (8) and S_2 (10) values, which correspond to the Trip Unit maximum Short Delay Pickup settings and M_1 (8) and M_2 (12) values, which correspond to the Trip Unit maximum Instantaneous Pickup settings.

The Rating Plug is equipped with a long-life 3.0 Volt lithium type battery. This back-up battery is not required for the basic Digitrip RMS/R Overcurrent Protective Circuit. It is used to maintain the Trip Unit mode of trip indication LEDs following a Breaker tripping operation, when no external 120 Vac control power source (through the ATR) to the Trip Unit is applied. A new battery will maintain the mode of trip LED for approximately 60 hours when no external 120 Vac source is applied to the Trip Unit. The battery is replaced from the front, without having to remove the Rating Plug from the Trip Unit. Replacement battery types are listed under the Accessories section of this Application Guide.

If a Rating Plug is removed when the Breaker is in the closed position, the Breaker may trip. Therefore, the Rating Plug must be securely plugged in and the Trip Cover put back on the Trip Unit to assure that the Rating Plug stays in place.

3-8. External Harness with Plug

The External Harness has multi-pin disconnect plugs that plug into the Trip Unit to extract Zone Interlocking, Remote Alarm, and IMPACC Communications Signals, as applicable, from the Trip Unit and to connect the 120 Vac power required on RMS 600, 700 & 800 Kits. The External Harness also has a large 20 pin plug that plugs into the Cell Harness Assembly which is mounted in the Switchgear Cell. The External Harness provided with RMS 500 Basic Kits consists of just a small jumper plug that sends out the Zone Interlock signals on the Trip Unit.

3-9. Potential Transformer Module (PTM)

A Potential Transformer Module (PTM) is supplied with each RMS 700 & 800 Kit. The PTM passes on Circuit Breaker primary voltage information to the Trip Unit for use in obtaining IMPACC energy monitoring data. Three 600 volt leads are provided for the PTM primary connection to the Breaker. These leads may be connected to either the Line side or Load side of the Breaker. The PTM secondary terminates to a 4 pin female plug (PT1) to permit connection to the Trip Unit via the 4 pin female plug provided on the External Wiring Harness.

CAUTION

THE PTM PRIMARY DISCONNECT PLUG MUST BE DISCONNECTED WHEN DIELECTRIC TESTING OF THE BREAKER/SWITCHGEAR ASSEMBLY IS PERFORMED OR THE TRIP UNIT MAY BE DAMAGED. DO NOT DISCONNECT THE PTM PLUG WHEN THE BREAKER IS ENERGIZED OR IN THE CONNECTED POSITION. MOVE THE BREAKER TO THE TEST POSITION BEFORE PULLING THE PTM PLUG.

3-10. Cell Harness Assembly

The Cell Harness Assembly is provided on all Retrofit Kits, except the RMS 500 Basic series. Its function is to extract the Zone Interlocking, Remote Alarm, and Communications Signals from the Breaker by connection to the External Wiring Harness and provide terminations for external customer connections. Use of the assembly reduces the time required for retrofit. It eliminates the need to completely rewire the secondary contacts on the Circuit Breaker and in the switchgear to accommodate the added Digitrip RMS signals.

The assembly mounts in the Breaker compartment of the switchgear on the right side sheet. The Cell Plug receives the Breaker External Harness Plug, providing a disconnecting means of extracting the signals from the Breaker. A Wiring Harness brings the signal to terminal blocks for customer external connections in the switchgear. Depending on the Retrofit Kit selected, up to 3 terminal blocks (TB1, TB2, and TB3) are provided.

Section 4

Digitrip RMS 500 Basic Retrofit Kits (Without Zone Interlocking)

4-1. Digitrip RMS 500 Basic Retrofit Kit Selection and Content

The Digitrip RMS 500 Basic Retrofit Kit series provides basic Overcurrent protection only. The Retrofit Kits are available with the applicable Digitrip RMS/R 500 Trip Unit Overcurrent Trip functions, i.e. Long Time (L), Short Time (S), Instantaneous (I), and Ground Fault Time (G) Delays. The combinations available are LI, LS, LSI, LSG, LSI_G.

The complete Digitrip RMS 500 Basic Retrofit Kit is mounted on the Breaker. Therefore, no switchgear cell modifications or wiring are required. Zone Interlocking signals from the Trip Unit are not wired out from the Breaker. The External Harness, refer to Figure 4-1, provided consists of a small jumper plug that shorts out the Zone Interlock signals at the Trip Unit. Refer to Figure 4-2 for the Retrofit Kit wiring connections on the Breaker.

RMS/R 500 BASIC EXTERNAL HARNESS STYLE NO. 6502C83G01

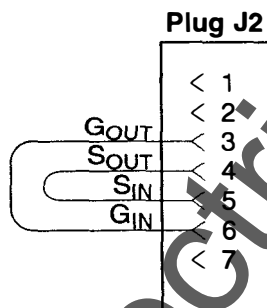

NOTICE:

Plug J2 must be installed with Zone Interlock Jumpers S_{IN}-S_{OUT} and G_{IN}-G_{OUT} or Breaker will trip instantaneously on Short Time and Ground Fault Delay functions.

Figure 4-1 Digitrip RMS/R 500 Basic External Harness

4-2. Digitrip RMS 500 Basic Retrofit Kit Features

The Digitrip RMS/R 500 Trip Unit has the following features available for customer use, when applied in the Digitrip RMS 500 Basic Retrofit Kit:

1. Basic (L,S,I,G) Overcurrent Protection, as selected.
2. True RMS Sensing.
3. Integral Trip Unit Testing.
4. Unit Status Indicator.
5. Local Mode of Trip Indicators.
6. Selectable I_{tr} on Short Time and Ground Fault Time Delays when those options are selected.

The Trip Unit also includes provisions to accept the required Rating Plug. The Rating Plug is equipped with a battery to power the local mode of trip indicators.

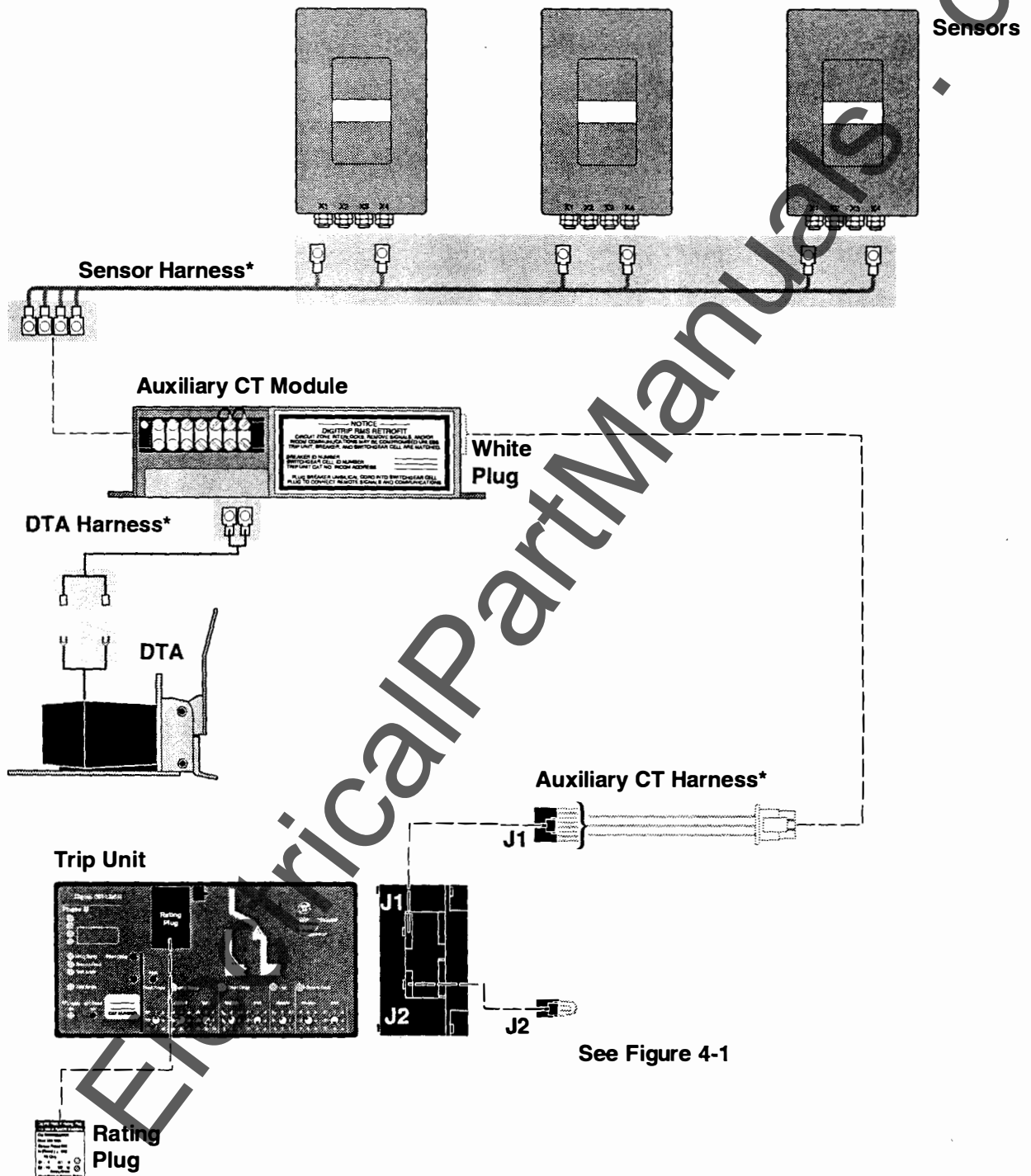

* See Section 12 for detailed wiring connection diagrams.

Figure 4-2 Digitrip RMS/R 500 Basic Wiring

Section 5

Digitrip RMS 500 Basic Retrofit Kits (With Zone Interlocking)

5-1. Digitrip RMS 500 Retrofit Kit (With Zone Interlocking) Selection and Content

The Digitrip RMS 500 Retrofit Kit series provides basic Overcurrent protection plus Zone Interlock capability. The Retrofit Kits are available with the applicable Digitrip RMS/R 500 Trip Unit Overcurrent Trip Functions, i.e. Long Time (L), Short Time (S), Instantaneous (I), and Ground Fault Time (G) Delays. The combinations available are LI, LS, LSI, LIG, LSG, LSIG.

Zone Interlocking signals are extracted from the Trip Unit by the umbilical Wiring Harness with plug. The umbilical Wiring Harness includes a 20 pin plug, which connects to the Cell Harness Assembly. All Retrofit Kit components are mounted on the Breaker, except the Cell Harness Assembly, which is mounted in the Switchgear Cell. Figures 5-1 through 5-3 provide the Retrofit Kit wiring connections on the Breaker and the Switchgear Cell.

5-2. Digitrip RMS 500 Retrofit Kit (With Zone Interlocking) Features

The Digitrip RMS/R 500 Trip Unit has the following features available for customer use, when applied in the Digitrip RMS 500 Basic Retrofit Kit:

1. Basic (L,S,I,G) Overcurrent protection, as selected.
2. True RMS Sensing.
3. Integral Trip Unit Testing.
4. Unit Status Indicator.
5. Local Mode of Trip Indicators.
6. Selectable I²t on Short Time and Ground Fault Time Delays when those options are selected.
7. Zone Interlock capabilities of the Breaker Short Time and Ground Fault Delay functions, when those options are selected.

The Trip Unit also includes provisions to accept the required Rating Plug. The Rating Plug is equipped with a battery to power the local mode of trip indicators.

**RMS/R 500 EXTERNAL HARNESS
STYLE NO. 6502C83G02**

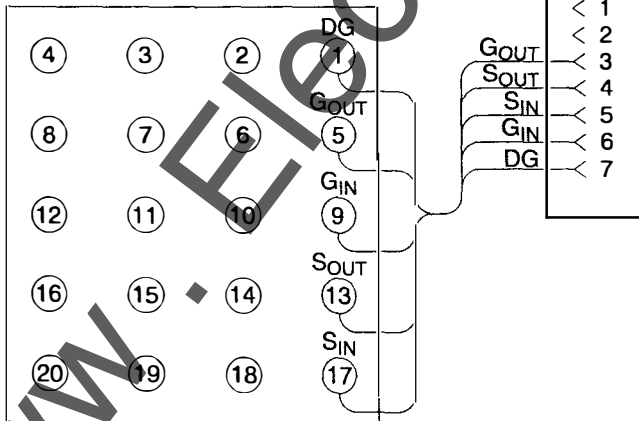
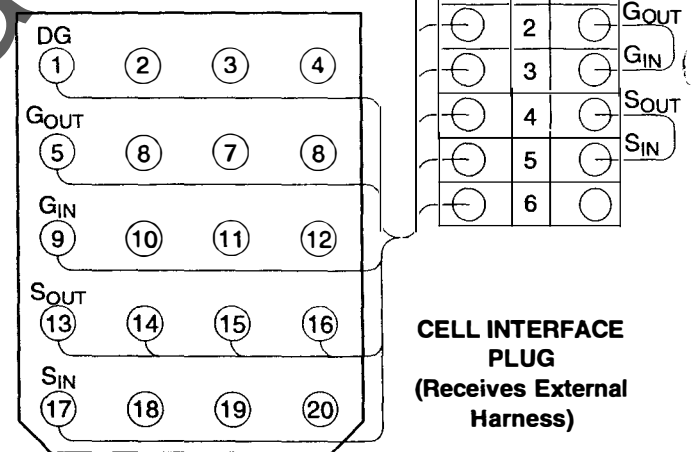

Figure 5-1 Digitrip RMS/R 500 External Harness

**RMS/R 500 CELL HARNESS
STYLE NO. 6502C71G01
6503C57G01**



**CELL INTERFACE PLUG
(Receives External Harness)**

Terminal Block Point & Marking	Description
TB1-1 DG	Zone Interlock Digital Ground
TB1-2 G _{OUT}	Zone Interlock Ground Output
TB1-3 G _{IN}	Zone Interlock Ground Input
TB1-4 S _{OUT}	Zone Interlock Short Delay Output
TB1-5 S _{IN}	Zone Interlock Short Delay Input

NOTICE:

1. Zone Interlock Jumpers S_{IN}-S_{OUT} and G_{IN}-G_{OUT} must be installed on TB1 or Breaker will trip instantaneously on Short Time and Ground Fault Delay functions. Remove jumpers ONLY if Zone Interlocking is required.
2. All wire terminators shown are furnished complete with Retrofit Kit Wiring Harness, except those indicated as customer connections.

Figure 5-2 Digitrip RMS/R 500 Cell Harness

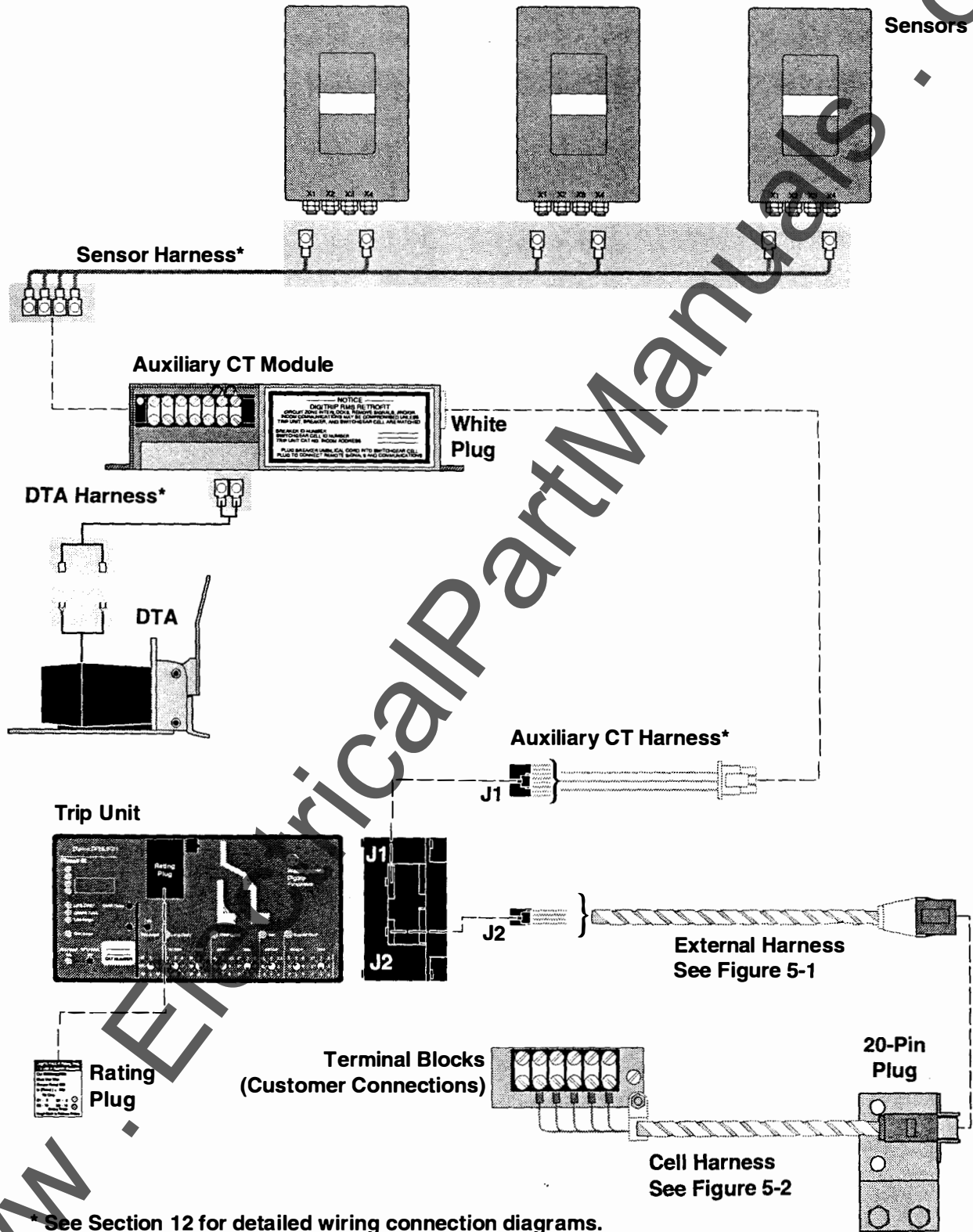

* See Section 12 for detailed wiring connection diagrams.

Figure 5-3 Digitrip RMS/R 500 Wiring

Section 6 Digitrip RMS 600 Basic Retrofit Kits

6-1. Digitrip RMS 600 Retrofit Kit Selection and Content

The Digitrip RMS 600 Retrofit Kit series provides Overcurrent protection, Zone Interlock capability and a local alphanumeric display. The Retrofit Kits are available with the applicable Digitrip RMS/R 500 Trip Unit Overcurrent Trip Functions, i.e. Long Time (L), Short Time (S), Instantaneous (I), & Ground Fault Time (G) Delays. The combinations available are LI, LS, LSI, LIG, LSG, LSIG.

In addition to Zone Interlocking, the RMS 600 Trip Units include the Power Relay Module (ATR) which provides contact closures for remote indication and alarm. Zone Interlocking and remote alarm signals are extracted from the Trip Unit by the External Harness with plug. The umbilical Wiring Harness includes a 20 pin plug, which connects to the Cell Harness Assembly.

An external 120 Vac control source is required to power up the Power Relay Module (ATR) remote signals, the local mode of trip indicators, and the Trip Unit alphanumeric digital display. Figures 6-1 through 6-3 provide the Retrofit Kit wiring connections on the Breaker and in the Switchgear Cell. All Retrofit Kit components are mounted on the Breaker, except the Cell Harness assembly, which is mounted in the Switchgear Cell.

6-2. Digitrip RMS 600 Retrofit Kit Features

The Digitrip RMS 600 Trip Unit has the following features available for customer use, when applied in the Digitrip RMS 600 Retrofit Kit:

1. Basic (L,S,I,G) Overcurrent protection, as selected.
2. True RMS Sensing.
3. Integral Trip Unit Testing.
4. Unit Status Indicator.
5. Local Mode of Trip Indicators.
6. Selectable 1st on Short Time and Ground Fault Time Delays when those options are selected.
7. Zone Interlock capabilities of the Breaker Short Time and Ground Fault Delay functions, when those options are selected.
8. Local Four Digit alphanumeric Display.
9. Remote Signal Contacts for high load and mode of trip indication.

The Trip Unit also includes provisions to accept the required Rating Plug. The Rating Plug is equipped with a battery to light the local mode of trip indicators if external 120 Vac control power is lost.

**RMS/R 600 EXTERNAL HARNESS
STYLE NO. 6502C83G03**

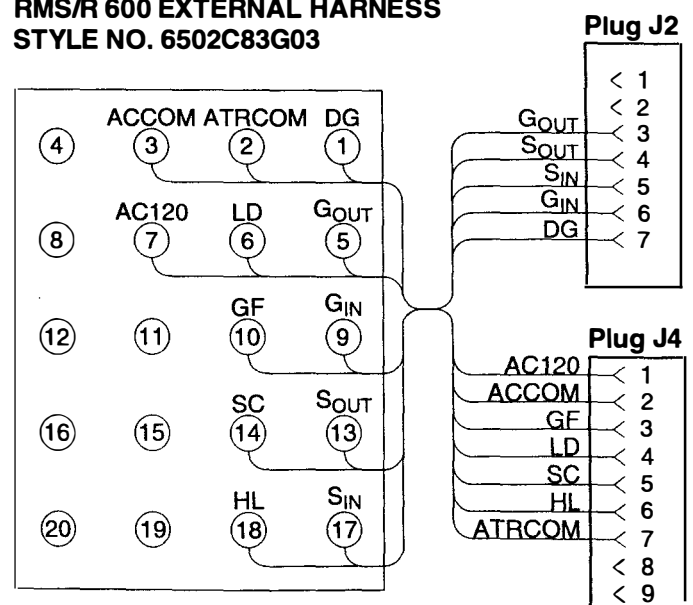
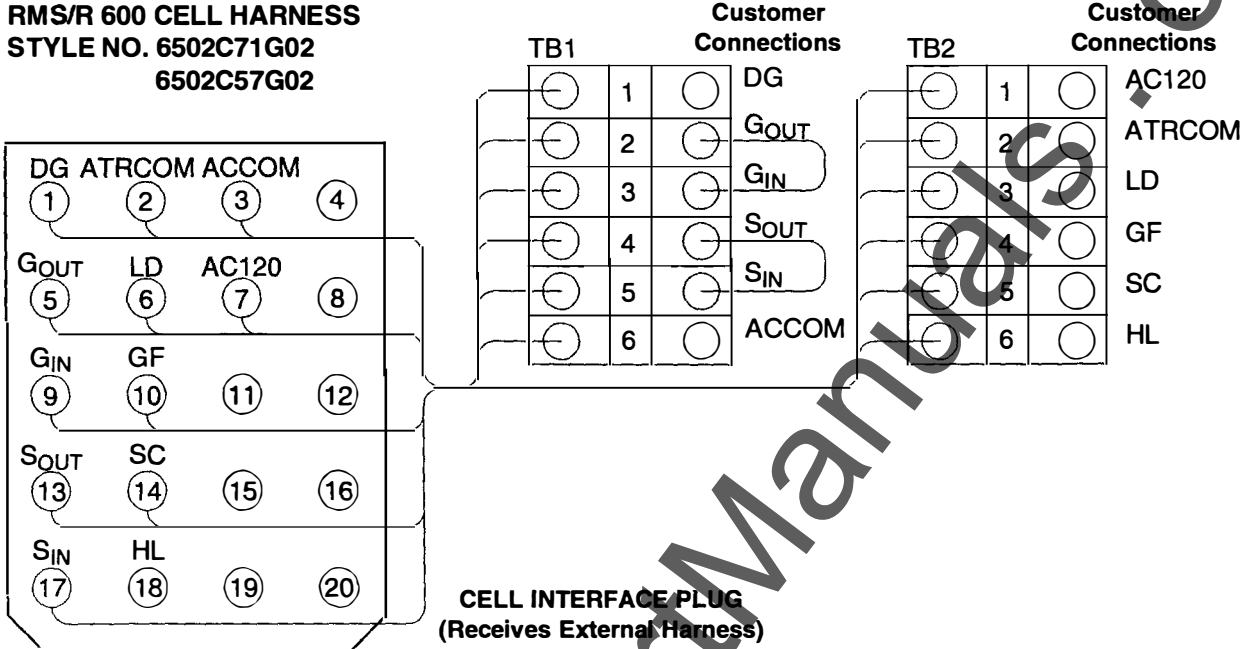

Figure 6-1 Digitrip RMS/R 600 External Harness

RMS/R 600 CELL HARNESS
STYLE NO. 6502C71G02
6502C57G02



Terminal Block Point & Marking	Description
TB1-1 DG	Zone Interlock Digital Ground
TB1-2 G _{OUT}	Zone Interlock Ground Output
TB1-3 G _{IN}	Zone Interlock Ground Input
TB1-4 S _{OUT}	Zone Interlock Short Delay Output
TB1-5 S _{IN}	Zone Interlock Short Delay Input
TB1-6 ACCOM	ATR 120 Vac Input Comm
TB2-1 AC 120	ATR 120 Vac Input Power
TB2-2 ATRCOM	ATR Alarm Contact Common
TB2-3 LD	ATR Long Delay Trip Alarm
TB2-4 GF	ATR Ground Fault Trip Alarm
TB2-5 SC	ATR Short Circuit Trip Alarm
TB2-6 HL	ATR High Load Alarm

NOTICE:

1. Zone Interlock Jumpers S_{IN}-S_{OUT} and G_{IN}-G_{OUT} must be installed on TB1 or Breaker will trip instantaneously on Short Time and Ground Fault Delay functions. Remove jumpers ONLY if Zone Interlocking is required.
2. All wire terminators shown are furnished complete with Retrofit Kit Wiring Harness, except those indicated as customer connections.
3. ATR contacts are rated 1 ampere at 120 Vac or 1 ampere at 28 Vdc.

Figure 6-2 Digitrip RMS/R 600 Cell Harness

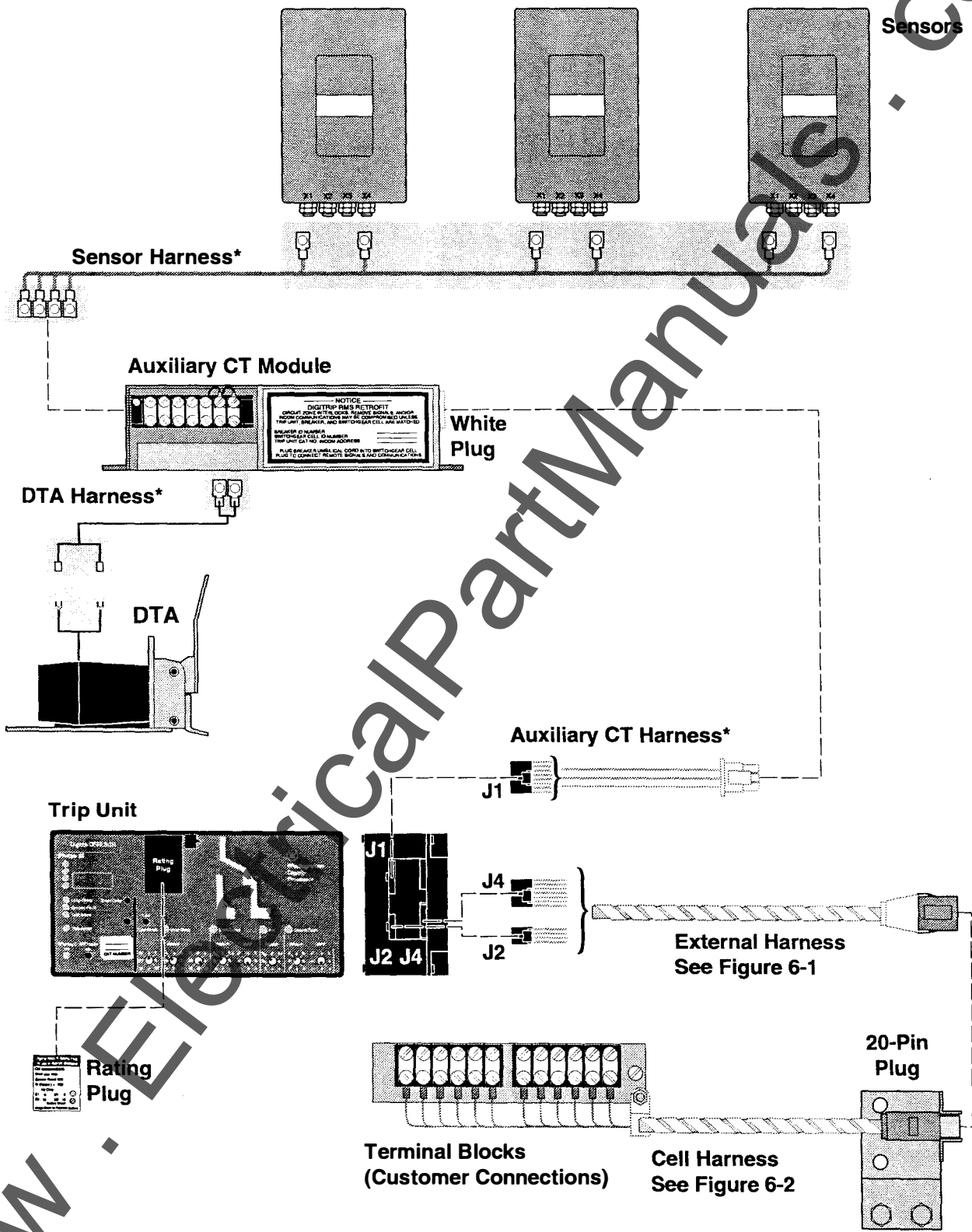

*See Section 12 for detailed wiring connection diagrams.

Figure 6-3 Digitrip RMS/R 600 Wiring

Section 7

Digitrip RMS 700 & 800 Basic Retrofit Kits

7-1. Digitrip RMS 700 & 800 Retrofit Kit Selection and Content

The Digitrip RMS 700 & 800 Retrofit Kit series are the top of the line of Retrofit Kits. The Retrofit Kits are available with the applicable Digitrip RMS/R 500 Trip Unit Overcurrent Trip Functions, i.e. Long Time (L), Short Time(S), Instantaneous (I), & Ground Fault Time (G) Delays. The combinations available are LI, LS, LSI, LIG, LSG, LSIG.

Digitrip RMS 700 & 800 Retrofit Kits feature Communications Capability when applied with the Cutler-Hammer Integrated Monitoring Protection and Control Communications (IMPACC) System. The RMS 700 & 800 Kits have essentially the same content, except the RMS 800 Trip Unit has a local Alphanumeric Display. The Communication, Zone Interlocking, and Remote Alarm Signals are extracted from the Trip Unit by an umbilical Wiring Harness with plug. The umbilical Wiring Harness includes a 20 pin plug, which connects to the Cell Harness Assembly.

An external 120 Vac control source is required to power up the Power Relay Module (ATR) remote signals, the

local mode of trip indicators, IMPACC Communications, and the Digitrip RMS 800 Unit alphanumeric digital display. A Potential Transformer Module (PTM) provides the distribution system voltage input to the Trip Unit. The PTM is provided with a disconnect plug which is to be disconnected in the event of Breaker dielectric testing. Figures 7-1 through 7-4 provide the Retrofit Kit wiring connections on the Breaker and in the Switchgear Cell. All Retrofit Kit components are mounted on the Breaker, except the Cell Harness Assembly.

7-2. Digitrip RMS 700 & 800 Retrofit Kit Features

Digitrip RMS 700 & 800 Trip Units have the following features available for customer use, when applied in Digitrip RMS Retrofit Kits:

1. Basic (L,S,I,G) Overcurrent Protection, as selected.
2. True RMS Sensing.
3. Integral Trip Unit Testing.
4. Unit Status Indicator.
5. Local Mode of Trip Indicators.
6. Selectable I²t on Short Time and Ground Fault Time Delays when those options are selected.

**RMS/R 700/800 EXTERNAL HARNESS
STYLE NO. 6502C83G04**

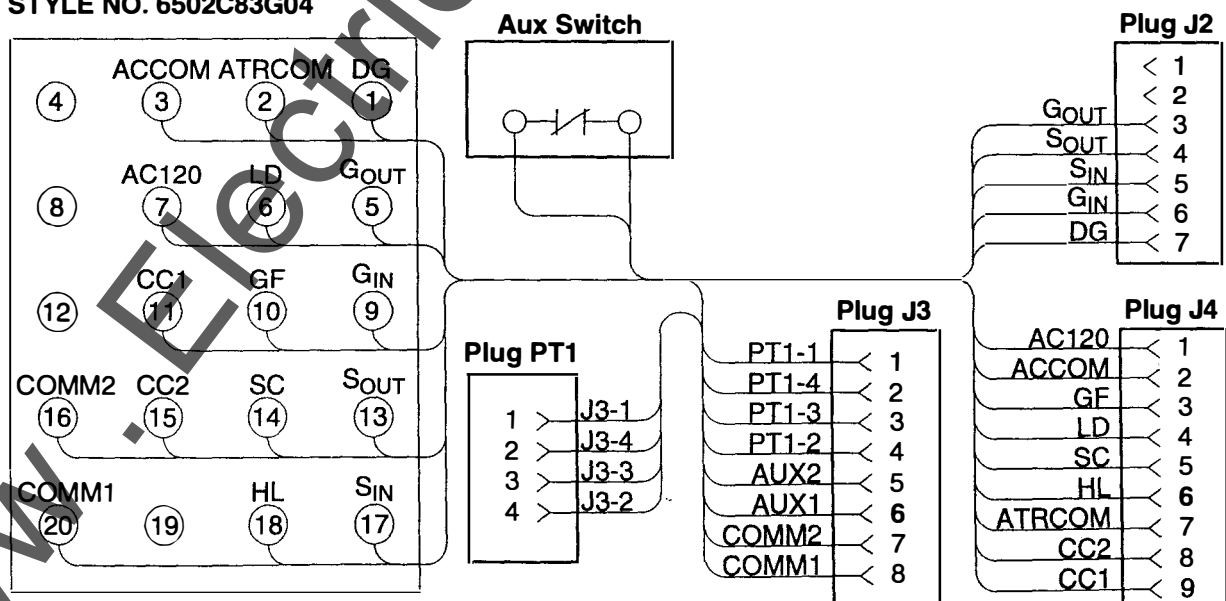

Figure 7-1 Digitrip RMS/R 7/800 External Harness

- 7. Zone Interlock capabilities of the Breaker Short Time and Ground Fault Delay functions, when those options are selected.
- 8. Local Four Digit Alphanumeric Display (Digitrip RMS 800 only).
- 9. Remote Signal Contacts for high load and mode of trip indication.

- 10. Communications when applied with the Cutler-Hammer IMPACC System.
- 11. Energy Monitoring Capability.

The Trip Unit also includes provisions to accept the required Rating Plug. The Rating Plug is equipped with a battery to light the local mode of trip indicators if the external 120 Vac control power is lost.

**RMS/R 700/800 CELL HARNESS
STYLE NO. 6502C71G03
6503C57G03**

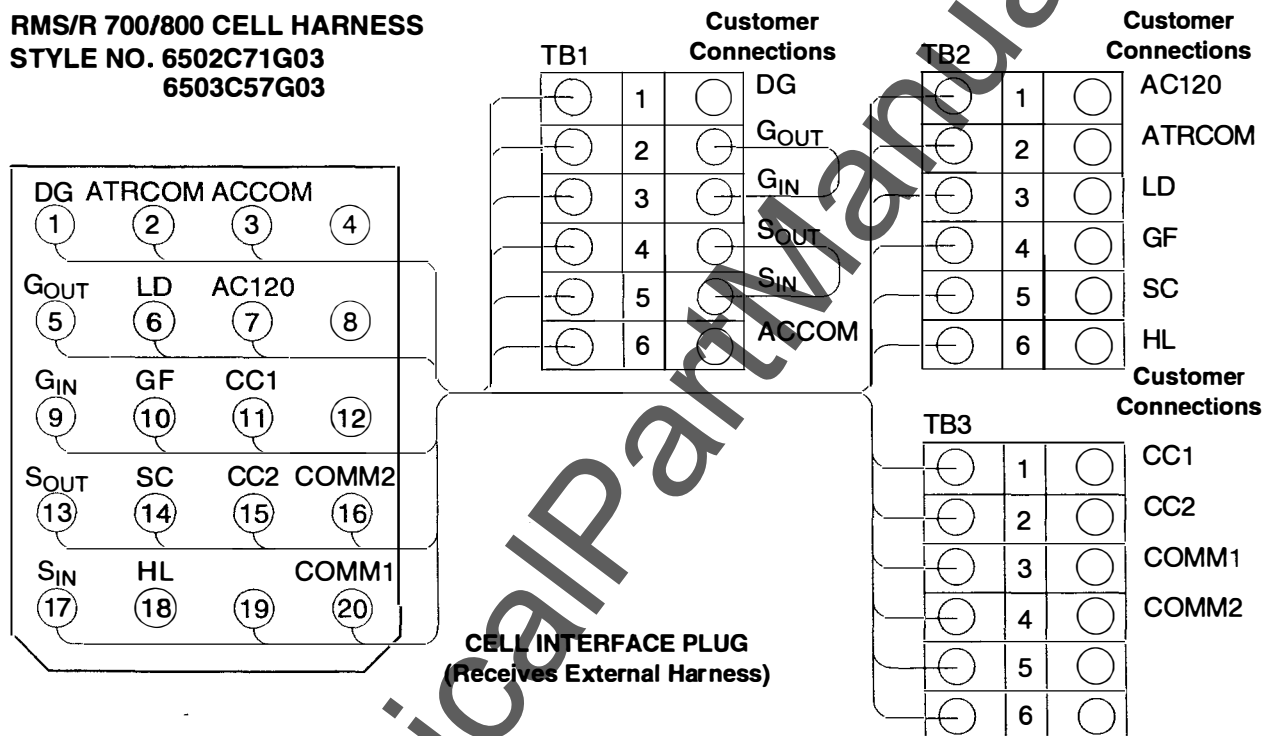

Terminal Block Point & Marking

Point & Marking	Description
TB1-1 DG	Zone Interlock Digital Ground
TB1-2 G _{OUT}	Zone Interlock Ground Output
TB1-3 G _{IN}	Zone Interlock Ground Input
TB1-4 S _{OUT}	Zone Interlock Short Delay Output
TB1-5 S _{IN}	Zone Interlock Short Delay Input
TB1-6 ACCOM	ATR 120 Vac Input Comm
TB2-1 AC 120	ATR 120 Vac Input Power
TB2-2 ATRCOM	ATR Alarm Contact Common*
TB2-3 LD	ATR Long Delay Trip Alarm*
TB2-4 GF	ATR Ground Fault Trip Alarm*
TB2-5 SC	ATR Short Circuit Trip Alarm*
TB2-6 HL	ATR High Load Alarm*

Terminal Block Point & Marking

Point & Marking	Description
TB3-1 CC1	IMPACC Contact Output to Breaker Remote Close Contact*
TB3-2 CC2	IMPACC Contact Output to Breaker Remote Close Contact*
TB3-3 COMM1	IMPACC Twisted Pair Connection
TB3-4 COMM2	IMPACC Twisted Pair Connection
TB3-5	Free Terminal for Twisted Pair Shield, Etc.
TB3-6	Free Terminal for Twisted Pair Shield, Etc.

NOTICE:

- 1. Zone Interlock Jumpers S_{IN}-S_{OUT} and G_{IN}-G_{OUT} must be installed on TB1 or Breaker will trip instantaneously on Short Time and Ground Fault Delay functions. Remove jumpers ONLY if Zone Interlocking is required.
 - 2. All wire terminators shown are furnished complete with Retrofit Kit Wiring Harness, except those indicated as customer connections.
- *ATR contacts are rated 1 ampere at 120 Vac or 1 ampere at 28 Vdc.

Figure 7-2 Digitrip RMS/R 7/800 Cell Harness

7-3. Power Flow Convention

For RMS 700 & 800 kits, proper Power Flow Conventions must be maintained as follows to assure the Trip Unit reads positive power. The factors which affect this are the Direction of Power Flow, the Location of the Sensors (Top or Bottom), and the Polarity of the Sensor Connections.

In describing the Sensor Polarity, the "Common" is the Green Wire, and the "Dot" is the Polarity Mark usually near the X1 terminal on the Sensor.

Table 7-1 should be consulted to determine the proper arrangement to allow the Trip Unit to read power properly. In all cases shown the Current Sensors are mounted with the Sensor Nameplates facing out, so that they can be read with the Sensor installed on the Breaker.

7-4. IMPACC Communications Wiring Checkout

The Trip Unit, Umbilical Cord, and Cell Harness wiring for IMPACC communications can be confirmed as follows:

1. Remove customer twisted-pair connections COMM1, COMM2 (TB3-3, TB3-4).
2. Remove external 120 Vac power.
3. Connect ohm-meter to TB3-3, TB3-4.
4. Keep the umbilical cord connected.
5. The ohm-meter should read approximately 470K ohms.
6. If (5) is OK, then the wiring is confirmed. Remove ohm-meter and replace wiring removed in Steps (1) and (2).

**RMS/R 700/800 PT MODULE
STYLE NO. 6502C82G01
8188A44G01**

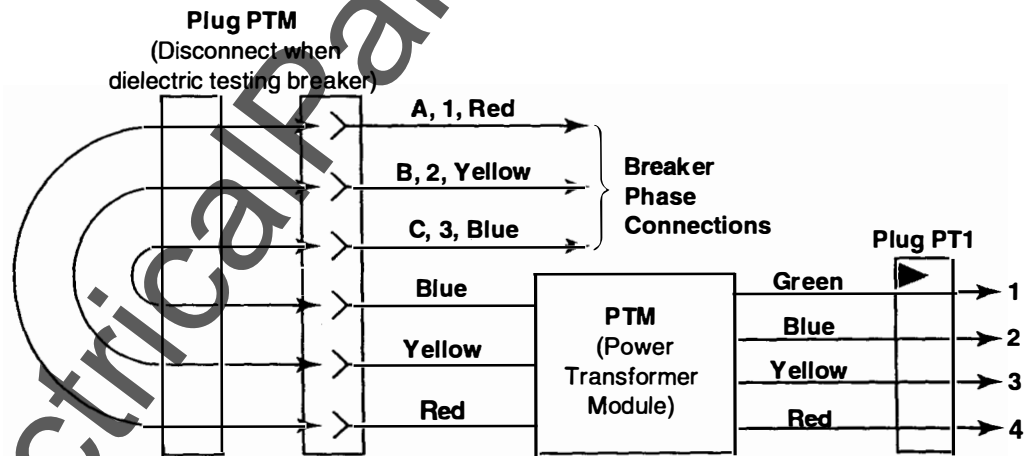
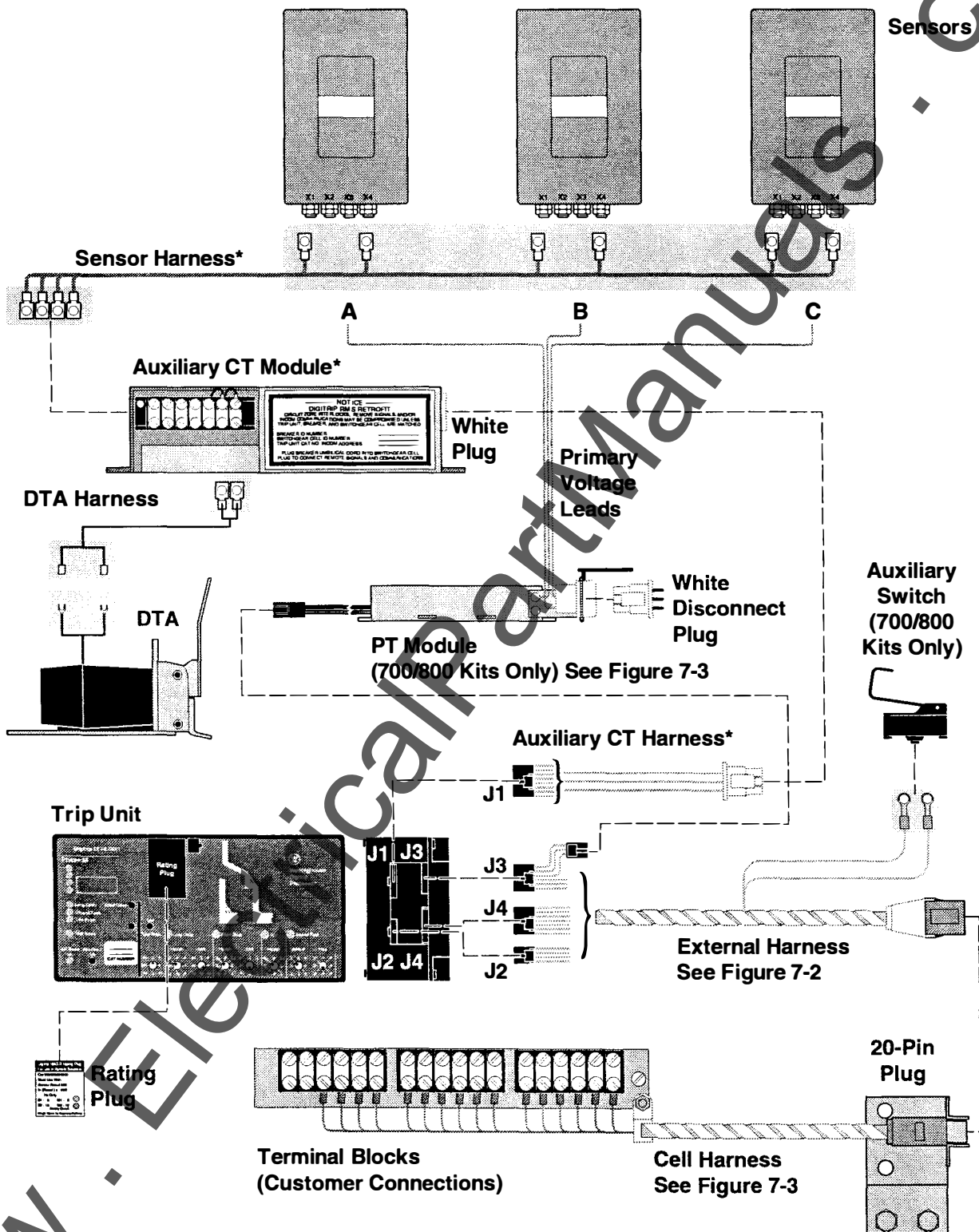

Figure 7-3 Digitrip RMS/R 700/800 PT Module

**Table 7-1
Power Flow Conventions**

Power Flow	Sensor Mounting	Sensor Polarity
Top to Bottom	Top	Common (Green Wire) AWAY FROM Dot (X1)
Top to Bottom	Bottom	Common (Green Wire) ON Dot (X1)
Bottom to Top	Top	Common (Green Wire) ON Dot (X1)
Bottom to Top	Bottom	Common (Green Wire) AWAY FROM Dot (X1)



* See Section 12 for detailed wiring connection diagrams.
See Section 7.3 for power flow conversions.

Figure 7-4 Digitrip RMS/R 7/800 Wiring

Section 8

Testing Retrofitted Breakers

8-1. Dielectric and Meggar Testing



WARNING

REFER TO SECTION 1 ENTITLED "GENERAL INFORMATION AND SAFETY PRECAUTIONS" AND REVIEW ALL THE DIRECTIONS SET FORTH IN THAT SECTION, PRIOR TO STARTING ANY TESTING PROCEDURE. FAILURE TO FOLLOW THE SAFE PRACTICES RECOMMENDED IN SECTION 1 COULD RESULT IN PERSONAL INJURY, DEATH AND/OR EQUIPMENT DAMAGE. TESTING SHOULD ONLY BE CARRIED OUT BY PERSONNEL FAMILIAR WITH THE HAZARDS ASSOCIATED WITH WORKING ON POWER CIRCUIT BREAKERS AND SWITCHGEAR ASSEMBLIES.

CAUTION

TO AVOID POSSIBLE DAMAGE TO TRIP UNIT, PERFORM THE FOLLOWING TWO STEPS BEFORE APPLYING MORE THAN 635 VOLTS TO A BREAKER RETROFITTED WITH A DIGITRIP RMS TRIP SYSTEM:

- 1. On Kits with an Umbilical Cord disconnect the Breaker Umbilical Plug, which connects the External Breaker Cell wiring.**
- 2. Disconnect Potential Transformer Model Plug PTM, which disconnects the Breaker Primary Voltage from the Trip Unit. (RMS 700 & 800 Trip Unit Models only).**

8-2. Testing the Digitrip RMS Trip System

The Digitrip RMS Overcurrent Trip System may be tested by using one of three possible methods, including the Digitrip Self Test, the Amptector Test Kit (with the use of an Amptector Test Kit Adapter Harness), and Primary Injection Testing (e.g. Multi-Amp or ELL).

GENERAL NOTES ON TESTING:

1. Each retrofitted Breaker must be Primary Injection tested to confirm the entire system operation (including Sensors) prior to installation, Secondary Injection testing or Self Test may be used for preventative maintenance testing hereinafter.
2. Each Retrofitted Breaker must be set-up per the distribution system coordination study prior to installation.
3. Trip Units are calibrated and sealed at the factory.
4. Each pick-up or time setting is selected on an eight position switch.
5. Each switch setting has a system tolerance band (shown in Figures 3-2, 3-3 and 3-4 Time-Current Curves).
6. Field testing confirms that the Trip System performs properly according to its tolerance bands.
7. Field testing of pick-up currents is recommended at two levels:
 - Current somewhat below the minimum tolerance band level (to confirm pick-up has not occurred).
 - Current somewhat above the maximum tolerance band level (to confirm pick-up has occurred).
 - Testing time should be the shortest necessary to confirm pick-up status (to limit thermal energy absorbed by the system) – approximately 5 seconds.

8. Field testing of Tripping Times –
 - Confirms that the system trips within the tolerance band
 - 6x current and 10 second time is recommended for Long Delay Tripping time testing (for ease of calculating +0% - 33% time tolerance band and to limit thermal energy absorbed by the system).

9. Digitrip RMS has a memory circuit that simulates the time required to cool down overloaded conductors. When performing repeated Long Delay Trip tests, the results may be erroneous as the Memory Circuit must discharge prior to the next test. The Memory Circuit can be discharged by disconnecting the external power source (Auxiliary Power Module or 120 Vac input through the External Harness) for 5 to 10 seconds between tests.

10. Due to Digitrip RMS Zone Interlocking capability, the Short Delay and Ground Fault Time Trip functions will trip instantaneously, unless Digitrip RMS/R 500 Basic External Harness Plug is placed into Trip Unit plug J2 to short G_{IN} to G_{OUT} and S_{IN} to S_{OUT} , see Figure 4-2. If a 500 Basic External Harness is not available and the kit is furnished with a 500, 600 or 700/800 External Harness, G_{IN} to G_{OUT} and S_{IN} to S_{OUT} can be shorted by plugging the Breaker External Harness into the Cell Plug of the Cell Harness Assembly, see Figure 5-1, 6-1, or 7-1.

band testing, Zone B, confirms that the pick-up will not occur below the minimum pick-up level. Above band testing, Zone C, confirms that the pick-up will occur at or above the minimum pick-up level. Figure 8-1 also shows the tolerance zone for trip times. Field time testing confirms that the Breaker will trip within this time zone.

Digitrip Trip Units are factory tested and calibrated. Field testing of the Retrofit Kits confirms that the Retrofitted Breaker meets the published Time-Current Curves shown in Figures 3-2, 3-3 and 3-4. Each pick-up or time setting on Digitrip Trip Units is selected by choosing one position of eight on each switch. Each switch setting has a tolerance band associated with it as defined in Figures 3-2, 3-3 and 3-4.

Figure 8-1 shows the Zones for pick-up and no pick-up. The Digitrip Unit must not pick-up below Zone A (the pick-up tolerance zone), and must always pick-up above Zone A. Field pick-up testing of the Kits must not be done within the tolerance zone (Zone A), since the Trip Unit may or may not pick-up within this zone. Below

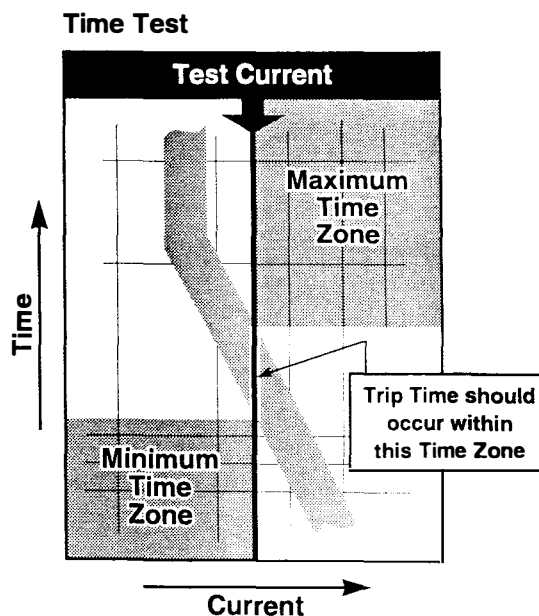
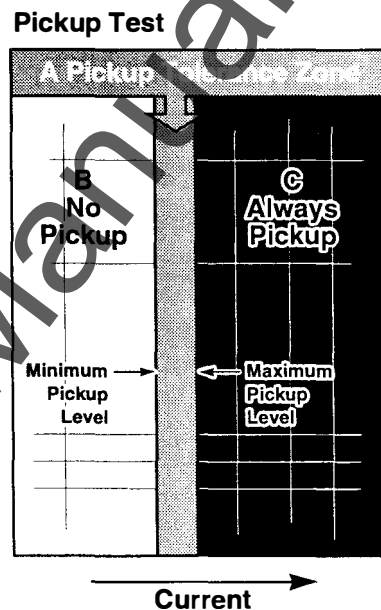

Figure 8-1 Pick-up Test and Time Test



8-3. Digitrip RMS Self Testing System



WARNING

USE OF THE DIGITRIP RMS SELF TEST SYSTEM WHILE THE BREAKER IS IN THE "CONNECTED" POSITION IN THE SWITCHGEAR CELL COMPARTMENT IS NOT RECOMMENDED. THE TRIPPING ACTION OF THE CIRCUIT BREAKER WILL CAUSE DISRUPTION OF SERVICE CAUSED BY UNNECESSARY SWITCHING OF CONNECTED EQUIPMENT.

TESTING SHOULD ONLY BE PERFORMED WHEN THE BREAKER IS LEVERED TO THE "TEST", "DISCONNECTED", OR "REMOVED" POSITIONS. FAILURE TO COMPLY WITH THESE RECOMMENDATIONS COULD RESULT IN INJURY, DEATH, AND/OR EQUIPMENT DAMAGE.

All Digitrip RMS and RMS/R Trip Units are equipped with self testing capability as standard. The self testing system requires one of two external power sources to operate:

- *Auxiliary Power Module (APM, Catalog Number PRTAAPM):* an optional accessory used to power the self testing system. The APM plugs into the Trip Unit Test Port, providing power from a 120 Vac 50/60 Hz circuit.
- *External 120 Vac Source:* The self test system for RMS 600, 700 & 800 retrofits can be powered by an external 120 Vac source applied to the Trip Unit through the Breaker External Harness. When 120 Vac source is supplied to terminals "AC120" and "ACCOM" of the Cell Harness Assembly and the Breaker External Harness is plugged into the cell plug, the self test circuit is powered.

Once the self test system is powered as described above, the trip unit can be enabled to simulate set test conditions. Refer to Section 8-3.1 within this section for specific settings on functional testing.

The "Test Amps" settings are 1, 2, 3, 6T, 8, 10, GFT, and GF each multiplied by the I_n rating. The Breaker will only trip to the open position when the (6T and GFT) settings are used.

The test is started by pushing the TEST push-button.

The Trip Unit will test itself based on the test and time overcurrent settings selected, lighting the "mode of trip" LEDs.

For RMS 600 and 800 Trip Units the alphanumeric digital display will register the elapsed time of the test until the "tripping point" and then register the "cause of trip" coded message on the Alphanumeric Digital display. The simulated fault current can then be viewed by depressing the STEP push-button.

Be sure to push the TRIP RESET push-button to reset the Trip Unit and the LEDs when testing is complete, or you may run down the rating plug battery.

8-3.1 Recommended Test Points for Digitrip RMS Units Using the Self-Test Function

- A. Provide power to the Trip Unit to operate the Self-Test Function use an Auxiliary Power Module (Cat. PRTAAPM) for Digitrip 500 Units. For 600, 700 or 800 units, refer to Figure 6-2 or Figure 7-2 to apply 120 Vac input power directly or use the Auxiliary Power Module. It is necessary to remove the input power between tests to reset the thermal memory of the Trip Unit.
- B. Refer to Table 8-1 to apply the proper settings for each of the eight function selection switches on the Trip Unit. The number of selector switches is dependent on the unctions (LSIG) of the Trip Unit; as a result, your Trip Unit may not have all of the selector switches in the diagram. Refer to Section 3-4 for additional information on the Trip Unit and its Time-Current Curves.
- C. If all of the tests from Table 8-1 yield correct results, the Trip Unit is functioning properly. If any difficulties are encountered during testing, please call Cutler-Hammer at 1-800-937-5487.

Table 8-1

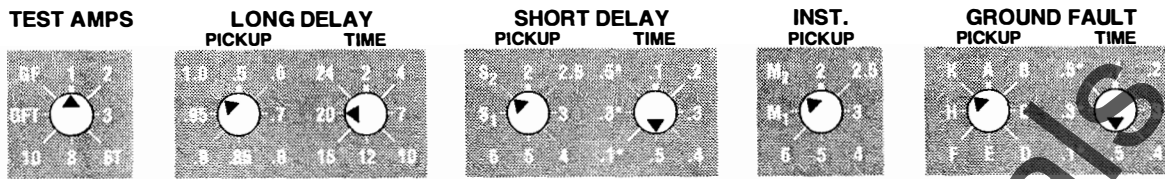

1. Long Delay Pickup Test (A):

1 1.0 20 S₂ .5[†] M₂ K .5[†]

EXPECTED RESULTS: Push the Trip Reset button, followed by the Test button. If the Trip Unit is functioning properly, no LED indicators will light. Push the Trip Reset button again.

2. Long Delay Pickup Test (B):

1 .95 20 S₂ .5[†] M₂ K .5[†]

EXPECTED RESULTS: Push the Test button. If the Trip Unit is functioning properly, the Long Delay LED will begin flashing. Remove power to the unit for at least 5 seconds. Re-apply power and push the Trip Reset button.

3. Long Time Test:

6T 1.0 20 S₂ .5[†] M₂ K .5[†]

EXPECTED RESULTS: Push the Test button and begin timing. If the Trip Unit is functioning properly, the Breaker will trip in between 13.3 and 20 seconds. The Long Delay LED will be flashing while timing out and solid after tripping. Remove power to the unit for at least 5 seconds. Re-apply power and push the Trip Reset button. Reset the Breaker.

4. Short Delay Pickup Test (A):

6T 1.0 20 S₁ .5[†] M₂ K .5[†]

EXPECTED RESULTS: Push the Test button and begin timing. If the Trip Unit is functioning properly, the Breaker will trip in between 13.3 and 20 seconds. The Long Delay LED will be flashing while timing out and solid after tripping. Remove power to the unit for at least 5 seconds. Re-apply power and push the Trip Reset button. Reset the Breaker.

5. Short Time Test (B):

6T 1.0 20 5 .5[†] M₂ K .5[†]

EXPECTED RESULTS: Push the Test button and begin timing. If the Trip Unit is functioning properly, the Breaker will trip in approximately 0.5 seconds. The Short Delay LED will be solidly lit after tripping. Remove power to the unit for at least 5 seconds. Re-apply power and push the Trip Reset button. Reset the Breaker.

6. Instantaneous Test (A):

6T 1.0 20 S₂ .5[†] M₁ K .5[†]

EXPECTED RESULTS: Push the Test button and begin timing. If the Trip Unit is functioning properly, the Breaker will trip in between 13.3 and 20 seconds. The Long Delay LED will be solidly lit after tripping. Remove power to the unit for at least 5 seconds. Re-apply power and push the Trip Reset button. Reset the Breaker.

7. Instantaneous Test (B):

6T 1.0 20 S₂ .5[†] 5 K .5[†]

EXPECTED RESULTS: Push the Test button and begin timing. If the Trip Unit is functioning properly, the Breaker will trip in approximately 0.1 seconds. The Instantaneous LED will be solidly lit after tripping. Remove power to the unit for at least 5 seconds. Re-apply power and push the Trip Reset button. Reset the Breaker.

8. Ground Fault Test (A):

GFT 1.0 20 S₂ .5[†] 5 K .5[†]

EXPECTED RESULTS: Push the Test button and begin timing. If the Trip Unit is functioning properly, the Breaker will trip in approximately 0.5 seconds. The Ground Fault LED will be solidly lit after tripping. Remove power to the unit for at least 5 seconds. Re-apply power and push the Trip Reset button. Reset the Breaker.

9. Ground Fault Test (B):

GFT 1.0 20 S₂ .5[†] 5 K .1[†]

EXPECTED RESULTS: Push the Test button and begin timing. If the Trip Unit is functioning properly, the Breaker will trip in approximately 0.1 seconds. The Ground Fault LED will be solidly lit after tripping. Remove power to the unit for at least 5 seconds. Re-apply power and push the Trip Reset button. Reset the Breaker.

[†] Do not use the .1*, .3* or .5*; the I²t settings.

8-4. Testing Digitrip with the Amptector Test Kit



WARNING

DO NOT USE THE AMPTECTOR TEST KIT TO TEST DIGITRIP RMS WHILE THE BREAKER IS IN THE "CONNECTED" POSITION IN THE SWITCHGEAR CELL COMPARTMENT. TESTING SHOULD ONLY BE PERFORMED WHEN THE BREAKER IS LEVERED TO THE "TEST", "DISCONNECTED" OR "REMOVED" POSITIONS. FAILURE TO COMPLY WITH THESE RECOMMENDATIONS COULD RESULT IN PERSONNEL INJURY, DEATH AND/OR EQUIPMENT DAMAGE.

CAUTION

POSSIBLE DAMAGE TO THE DIGITRIP MAY RESULT FROM THE USE OF STYLES 140D481G01R OR G02 AMPTECTOR TEST KITS. USE ONLY AMPTECTOR TEST KIT WITH STYLES 140E481G02R, 140D481G02RR, OR 140D481G03 FOR TESTING THE DIGITRIP TRIP UNIT.

Digitrip RMS/R Trip Units can be tested over a partial range using either style 140D481G02R, 140D481G02RR or 140D481G03 Amptector Test Kit and an Optional Test Kit Adapter Harness. The available Adapter Harnesses are listed in Table 2-2 and are described as follows:

- *Amptector Test Kit Adapter Harness Type 1:* includes a receptacle for receiving the Test Kit Banana Plug and a set of 7 color-coded spade type terminals for connecting to the Auxiliary CT Module Terminal Block Terminals A through ON. This harness must be manually connected to each Breaker during the test and then removed afterward.
- *Amptector Test Kit Adapter Harness Type 2:* includes a receptacle for receiving the Test Kit Banana Plug and a multi-pin male plug to provide quick connection to the Breaker Mounted Test Plug. The Breaker Mounted Test Plug is an optional accessory, sold as a kit for permanent mounting on each Breaker. It includes a female multi-pin plug with a set of 7 color-coded spade type terminals, which connect to Auxiliary CT Module Terminal Block terminals A through ON. During testing, Adapter Harness Type 2 is plugged into the Breaker Mounted Test Plug and then removed afterward.

NOTICE: The Amptector Test Kit produces a maximum of 30 to 35 amperes when connected to the Test Kit Adapter Harness. The Test Kit outputs are limited to 6-7 times the Rating Plug I_n Rating. This restricts the test range for Short Delay and Instantaneous Testing, but still provides for testing the Long Delay Pickup and Long Delay Time Trip Functions. When testing with the Amptector Test Kit, an external power source to the Trip Unit is required if the Alphanumeric Digital display or the communications features are to be checked. Use either the Auxiliary Power Module (APM) or the 120 Vac input through the Breaker Umbilical Cord (RMS 600, 700, or 800 only) as discussed above. Additional information for testing Digitrip RMS with the Amptector test kit is listed in the REFERENCES section of this document.

8-4.1 Recommended Test Points for Digitrip RMS Units Using Cutler-Hammer Amptector Test Set

- A. Provide power to the Trip Unit for proper operation use an Auxiliary Power Module (Cat. PRTAAPM) for Digitrip 500 Units. For 600, 700 or 800 units, refer to Figure 6-2 or Figure 7-2 to apply 120 Vac input power directly or use the Auxiliary Power Module. Power to the Trip Unit is necessary in order to allow the Amptector test set to read correctly; but the power must be removed between the tests to reset the thermal memory of the Trip Unit.
- B. Make sure that the Amptector test set shuts off automatically when the Breaker trips to prevent potential damage to the Trip Unit.
- C. Refer to Table 8-2 to apply the proper settings for each of the eight function selection switches on the Trip Unit. The number of selector switches is dependent on the functions (LSIG) of the Trip Unit; as a result, your Trip Unit may not have all of the switches as shown in Table 8-2.

The tester secondary amps shown in Table 8-2 are for 100% Rating Plugs, where the Plug Rating (I_n) and Sensor Rating are the same. If your Rating Plug is not 100%, it will be necessary to ratio the secondary amps accordingly.

- D. If all of the tests from Table 8-2 yield correct results, the Trip Unit is functioning properly. If any difficulties are encountered during testing, please call Cutler-Hammer at 1-800-937-5487.

Table 8-2

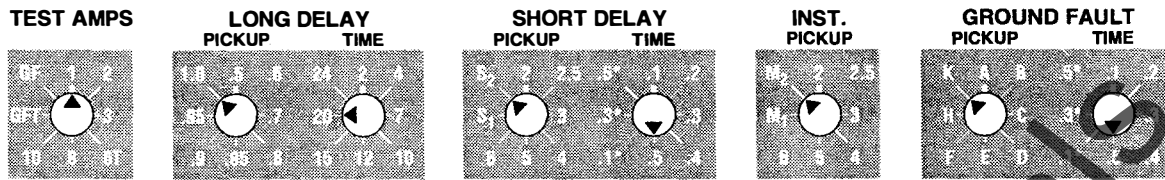

1. Long Delay Pick-up Test (A): Secondary Amps = 4.9 amps

1 1.0 20 S₂ .5 † M₂ K .5 †

EXPECTED RESULTS: Close the Breaker. Push the Trip Reset button, followed by the Test button. If the Trip Unit is functioning properly, no LED indicators will light. Push the Trip Reset button again.

2. Long Delay Pick-up Test (B): Secondary Amps = 5.7 amps

1 1.0 20 S₂ .5 † M₂ K .5 †

EXPECTED RESULTS: Push the Test button. If the Trip Unit is functioning properly, the Long Delay LED will begin flashing. Stop the test. Remove power to the Trip Unit for at least 5 seconds. Re-apply power and push the Trip Reset button.

3. Long Time Test: Secondary Amps = 30 amps

1 1.0 20 S₂ .5 † M₂ K .5 †

EXPECTED RESULTS: Push the Test button and begin timing. If the Trip Unit is functioning properly, the Breaker will trip in between 19 and 29 seconds. The Long Delay LED will be flashing while timing out and solid after tripping. Remove power to the unit for at least 5 seconds. Re-apply power and push the Trip Reset button. Reset the Breaker.

4. Short Delay Pick-up Test (A): Secondary Amps = 25 amps

1 1.0 20 6 .5 † M₂ K .5 †

EXPECTED RESULTS: Push the Test button and begin timing. If the Trip Unit is functioning properly, the Breaker will trip in between 13.3 and 20 seconds. The Long Delay LED will be flashing while timing out and solid after tripping. Remove power to the unit for at least 5 seconds. Re-apply power and push the Trip Reset button. Reset the Breaker.

5. Short Time Pick-up Test (B): Secondary Amps = 35 amps

1 1.0 20 6 .5 † M₂ K .5 †

EXPECTED RESULTS: Push the Test button and begin timing. If the Trip Unit is functioning properly, the Breaker will trip in approximately 0.5 seconds. The Short Delay LED will be solidly lit after tripping. Remove power to the unit for at least 5 seconds. Re-apply power and push the Trip Reset button. Reset the Breaker.

6. Instantaneous Pick-up Test (A): Secondary Amps = 25 amps

1 1.0 20 S₂ .5 † 6 K .5 †

EXPECTED RESULTS: Push the Test button and begin timing. If the Trip Unit is functioning properly, the Breaker will trip in between 19 and 29 seconds. The Long Delay LED will be solidly lit after tripping. Remove power to the unit for at least 5 seconds. Re-apply power and push the Trip Reset button. Reset the Breaker.

7. Instantaneous Pick-up Test (B): Secondary Amps = 35 amps

1 1.0 20 S₂ .5 † 6 K .5 †

EXPECTED RESULTS: Push the Test button and begin timing. If the Trip Unit is functioning properly, the Breaker will trip in less than 0.1 seconds. The Instantaneous LED will be solidly lit after tripping. Remove power to the unit for at least 5 seconds. Re-apply power and push the Trip Reset button. Reset the Breaker.

8. Ground Fault Pick-up Test (A): Secondary Amps = 1.0 amps

1 1.0 20 S₂ .5 † 5 A .5 †

EXPECTED RESULTS: Push the Test button and begin timing. If the Trip Unit is functioning properly, the Breaker will not trip. Remove power to the unit for at least 5 seconds. Re-apply power and push the Trip Reset button.

9. Ground Fault Pick-up Test (B): Secondary Amps = 1.5 amps

1 1.0 20 S₂ .5 † 5 A .5 †

EXPECTED RESULTS: Push the Test button and begin timing. If the Trip Unit is functioning properly, the Breaker will trip in approximately 0.5 seconds. The Ground Fault LED will be solidly lit after tripping. Remove power to the unit for at least 5 seconds. Re-apply power and push the Trip Reset button. Reset the Breaker.

† Do not use the .1*, .3* or .5*; the I²t settings.

8-5. Primary Injection Testing

Primary injection testing is a useful alternative to the secondary injection methods described previously. Primary injection verifies the complete Breaker Overcurrent Protection System, including the Current Sensors, Rating Plug, Trip Unit, and the interconnecting wiring. It involves the use of a tester, e.g. Multi-Amp Tester or EIL, to inject single phase primary current through the Breaker to test the Digitrip RMS Overcurrent Trip System.

When testing Breakers equipped with Ground Fault (G) protection, Auxiliary CT Module Terminals G and N can be shorted together with a suitable jumper to temporarily defeat the Ground Fault Trip Function. This will enable the Breaker to be tested in the Long Delay portion of the curve without tripping on ground fault. The jumper must be removed after testing to reinstate the ground fault protection on the Breaker.

When testing on Breakers with current limiters, the current limiters should be removed and replaced by copper shorting bars during testing. Failure to do so could result in compromising the expected performance of the current limiters. The current limiters must be reinstalled after testing is completed.

When testing, an external power source to the Trip Unit is required if the Alphanumeric Digital Display or the communications features are to be checked. Use either the Auxiliary Power Module (APM) or the 120 Vac input through the Breaker Umbilical Cord (RMS 600, 700, or 800 only) as discussed above.

8-5.1 Recommended Test Points for Digitrip RMS Units Using Primary Injection Tester



PRIMARY INJECTION TESTING CAUSES HEATING OF CIRCUIT BREAKER AND RETROFIT COMPONENTS. FAILURE TO STOP TESTS WHEN INSTRUCTED WILL CAUSE SERIOUS DAMAGE TO BOTH THE BREAKER AND RETROFIT COMPONENTS.

- A. 120 Vac input power to the Trip Unit is not necessary during Primary Injection Testing; but it is recommended because it permits the Alphanumeric Display on Digitrip 600 or 800 units to operate. To provide 120 Vac input power to the Trip Unit, use an Auxiliary Power Module (Cat PRTAAPM) or refer to Figure 6-2 or Figure 7-2 to apply the power directly. It is necessary to remove the input power between tests to reset the thermal memory of the Trip Unit.
- B. Refer to Table 8-3 to apply the proper settings for each of the eight function selection switches on the Trip Unit. The number of selector switches is dependent on the functions (LSIG) of the Trip Unit; as a result, your Trip Unit may not have all of the switches as shown in Table 8-3.

The Primary Current settings shown in Table 8-3 are in percentages of the Plug Rating (I_n). Refer to Section 3-4 for additional information on the Trip Unit and its Time-Current Curves.
- C. If all of the tests from Table 8-3 yield correct results, the Trip Unit is functioning properly. If any difficulties are encountered during testing, please call Cutler-Hammer at 1-800-937-5487.

Table 8-3

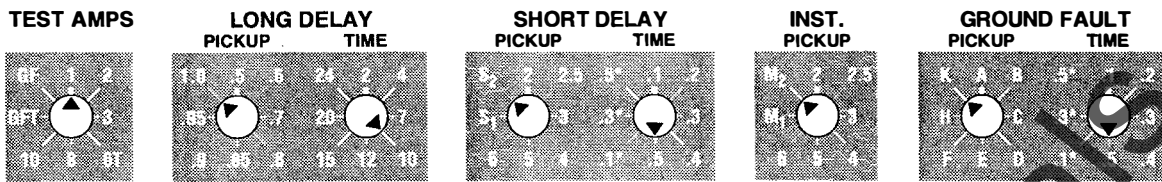

1. Long Delay Pick-up Test (A): Primary Test Current = 100% of I_n

1 1.0 10 S₂ .5 † M₂ K .5 †

EXPECTED RESULTS: Close the Breaker. Push the Trip Reset button, followed by the Test button. If the Trip Unit is functioning properly, no LED indicators will light. Stop the test within 10 seconds. Push the Trip Reset button again.

2. Long Delay Pickup Test (B): Primary Test Current = 115% of I_n

1 1.0 10 S₂ .5 † M₂ K .5 †

EXPECTED RESULTS: Push the Test button. If the Trip Unit is functioning properly, the Long Delay LED will begin flashing. Stop the test within 10 seconds. Remove power to the Trip Unit for at least 5 seconds. Re-apply power and push the Trip Reset button.

3. Long Time Test: Primary Test Current = 600% of I_n

1 1.0 10 S₂ .5 † M₂ K .5 †

EXPECTED RESULTS: Push the Test button and begin timing. If the Trip Unit is functioning properly, the Breaker will trip in between 6.7 and 10 seconds. The Long Delay LED will be flashing while timing out and solid after tripping. Remove power to the unit for at least 5 seconds. Re-apply power and push the Trip Reset button. Reset the Breaker.

4. Short Delay Pick-up Test (A): Primary Test Current = 500% of I_n

1 1.0 10 6 .5 † M₂ K .5 †

EXPECTED RESULTS: Push the Test button and begin timing. If the Trip Unit is functioning properly, the Long Delay LED will begin flashing. **STOP THE TEST WITHIN 5 SECONDS.** Remove power to the unit for at least 5 seconds. Re-apply power and push the Trip Reset button. Reset the Breaker.

5. Short Time Pick-up Test (B): Primary Test Current = 500% of I_n

1 1.0 10 S₂ .5 † 6 K .5 †

EXPECTED RESULTS: Push the Test button and begin timing. If the Trip Unit is functioning properly, the Long Delay LED will begin flashing. **STOP THE TEST WITHIN 5 SECONDS.** Remove power to the unit for at least 5 seconds. Re-apply power and push the Trip Reset button. Reset the Breaker.

6. Instantaneous Pick-up Test (A): Primary Test Current = 700% of I_n

1 1.0 10 6 .5 † M₂ K .5 †

EXPECTED RESULTS: Push the Test button and begin timing. If the Trip Unit is functioning properly, the Breaker will trip approximately 0.5 seconds. The Short Delay LED will be solidly lit after tripping. Remove power to the unit for at least 5 seconds. Re-apply power and push the Trip Reset button. Reset the Breaker.

7. Instantaneous Pick-up Test (B): Primary Test Current = 700% of I_n

1 1.0 10 S₂ .5 † 6 K .5 †

EXPECTED RESULTS: Push the Test button and begin timing. If the Trip Unit is functioning properly, the Breaker will trip in less than 0.1 seconds. The Instantaneous LED will be solidly lit after tripping. Remove power to the unit for at least 5 seconds. Re-apply power and push the Trip Reset button. Reset the Breaker.

8. Ground Fault Pick-up Test (A): Primary Test Current = 20% of I_n

1 1.0 20 S₂ .5 † 5 A .5 †

EXPECTED RESULTS: Push the Test button and begin timing. If the Trip Unit is functioning properly, the Breaker will not trip. Remove power to the unit for at least 5 seconds. Re-apply power and push the Trip Reset button.

9. Ground Fault Pick-up Test (B): Primary Test Current = 30% of I_n

1 1.0 10 S₂ .5 † 5 A .5 †

EXPECTED RESULTS: Push the Test button and begin timing. If the Trip Unit is functioning properly, the Breaker will trip in approximately 0.5 seconds. The Ground Fault LED will be solidly lit after tripping. Remove power to the unit for at least 5 seconds. Re-apply power and push the Trip Reset button. Reset the Breaker.

† Do not use the .1*, .3* or .5*; the I²t settings.

8-6. Circuit Breaker Checkout and Bench Test

Before the Breaker is returned to the Switchgear for placement into service, the Retrofit Kit installation must be checked out and tested. Check all Breaker retrofit wiring paths to be sure that they are properly routed and free from potential interference with Breaker moving parts. Confirm all Wiring Harness terminations are secure.

Perform several Breaker manual close and Overcurrent Trip Operations. This test can be performed using any of the above described test methods. An effective installation checkout and test procedures should include the following:

1. Select and set the proper user-determined Overcurrent Trip Settings for the Digitrip RMS Trip Unit. Verify the Trip Unit is in calibration by selecting and testing several trip points (as applicable) on the Long Delay, Short Delay, Instantaneous, and Ground Fault Time portions of the Digitrip RMS Trip Curve. Record the Trip Unit settings for permanent record and future reference.

GENERAL NOTES ON TESTING:

- Due to the Digitrip RMS Zone Interlocking functions, the Short Delay and Ground Fault Time Trip functions will trip instantaneously unless Digitrip RMS Terminal S_{IN} is shorted to S_{OUT} and G_{IN} to G_{OUT} .
 - Digitrip RMS has a memory circuit that simulates the time required to cool down of overloaded conductors. When performing repeated Long Delay Testing, the results may be erroneous as the Memory Circuit must discharge prior to the next test. The Memory Circuit can be discharged by disconnecting the power source (APM or 120 Vac input) to the Trip Unit between tests or by waiting several minutes between tests.
2. Verify the DTA properly resets. The breaker will not close unless the DTA resets.

3. For breakers equipped with OTS Switches, confirm the proper operation of the OTS switch. When the Breaker trips on an overcurrent condition, the OTS switch must latch and its contacts change state. If not, adjust the OTS switch as detailed in OTS SWITCH ADJUSTMENT PROCEDURE. Manually reset the OTS switch after each trip through the push-button on the Breaker Faceplate or electrically, if applicable, by energizing the OTS reset coil.

Before returning the Breaker to the Switchgear after the Breaker bench testing has been completed, lever the Breaker element levering mechanism from the "TEST" position to the "DISCONNECT" position. Confirm the Breaker position indicator read "OPEN" and the spring charged indicator reads "DISCHARGED".

8-7. Setting Digitrip RMS IMPACC Address (Digitrip RMS Models 700 & 800 Only)

NOTICE: Setting Digitrip RMS IMPACC address provides the Trip Unit a unique identification for communications. IMPACC Communications may be compromised unless Trip Unit, Breaker, and Switchgear Cell are matched.

Each Digitrip RMS Model 700 & 800 Trip Unit has three dip switches that must be set to provide the Trip Unit with a unique address for IMPACC Communications. The Rating Plug must be removed from the Trip Unit to obtain access to the dip switches. Each dip switch can be set with a small blade screwdriver from 0-9. The three switches have a sequence convention of top to bottom for a left to right address.

8-8. Identification of Trip Unit, Breaker, and Switchgear Cell

Your Digitrip RMS Retrofit Kit includes identification labels for the Digitrip RMS Trip Unit, the Breaker Element Faceplate, and the inside of the Switchgear Cell Door. It is important to identify all three, especially when the Trip Unit has an IMPACC address (Models 700 & 800 only).

Section 9 Operation

WARNING

REFER TO SECTION 1 ENTITLED "GENERAL INFORMATION AND SAFETY PRECAUTIONS" AND REVIEW ALL THE DIRECTIONS SET FORTH IN THAT SECTION, PRIOR TO STARTING ANY TESTING PROCEDURE. FAILURE TO FOLLOW THE SAFE PRACTICES RECOMMENDED IN SECTION 1 COULD RESULT IN PERSONAL INJURY, DEATH AND/OR EQUIPMENT DAMAGE. OPERATION OF THIS EQUIPMENT SHOULD ONLY BE CARRIED OUT BY PERSONNEL FAMILIAR WITH WORKING ON POWER CIRCUIT BREAKERS AND SWITCHGEAR ASSEMBLIES.

The information presented for the operation of Digitrip RMS Retrofitted Power Circuit Breakers and Switchgear supplements the content of the original equipment instruction manuals. Further, the information described supplements any established procedures in practice at the customer location.

WARNING

BREAKER AND SWITCHGEAR CELL RETROFIT INSTALLATIONS MUST BE CHECKED AND TESTED PRIOR TO PLACING THE EQUIPMENT IN OPERATION. SECTION 8 PROVIDES INFORMATION ON RECOMMENDED TESTING AND CHECKOUT PROCEDURES, FAILURE TO FOLLOW SUCH PROCEDURES COULD RESULT IN PERSONAL INJURY, DEATH AND/OR EQUIPMENT DAMAGE.

9-1. Breaker Insertion in Switchgear Cell and Power Up

WARNING

PRIOR TO INSERTING THE BREAKER INTO THE CELL, BE SURE THE BREAKER IS IN THE OPEN POSITION AND THE TRIP UNIT ADJUSTABLE SETTINGS ARE CORRECT. ADDITIONALLY, BE SURE THE TRIP UNIT, BREAKER AND SWITCHGEAR CELL ALL MATCH FOR THEIR INTENDED APPLICATION. FAILURE TO DO SO COULD RESULT IN PERSONAL INJURY, DEATH AND/OR EQUIPMENT DAMAGE

Rack the Breaker to the CONNECT position in the Switchgear Cell. RMS 500 Basic Retrofitted Breakers include no External Harness and are ready to be closed. For RMS 500 Zone, 600, 700, & 800 Retrofitted Breakers, plug the External Harness into the Cell Harness Assembly and then close the Breaker. The External Harness connects the External Trip Unit Signals. For RMS 600, 700, & 800 Retrofitted Breakers, the Trip Unit green Status LED will begin to blink when the plug is connected, indicating the Trip Unit is operational and the 120 Vac external source is on. For RMS 500 Basic and RMS 500 Zone Retrofitted Breakers, the Trip Unit green Status LED will begin to blink when the Breaker is closed and primary current of at least 25% of the Sensor Tap selected begins to flow.

NOTICE: *Digitrip RMS Overcurrent Protection is maintained, even when the Breaker External Harness Plug is not plugged into the Cell Harness Plug. The Digitrip RMS Overcurrent Trip System is internally powered by the primary phase currents passing through the Current Sensors.*

9-2. Information Available to Operator While Breaker is in Service

Table 9-1 lists the available information provided by Digitrip RMS Trip Units while the Breaker is in service.

Table 9-1

Data available local to or remote from the Digitrip RMS Trip Unit during operation.	RMS 500	RMS 600	RMS 700	RMS 800
Unit Status Green LED flashes to indicate normal operation of Trip Unit.	X	X	X	X
Long Delay Red LED flashes when Breaker is in Long Delay Pickup and timing out to trip.	X	X	X	X
High Load Red LED lights when current level stays within 85% of Long Delay Pickup for 40 seconds.		X		X
ATR High Load contact closes for remote indication when current level stays within 85% of Long Delay Pickup for 40 seconds.		X	X	X
Alphanumeric Digital Display, showing:				
LDPU (Flashing) when Breaker in Long Delay Pickup		X		X
Individual Phase Currents (reading in amps X 1000)		X		X
Ground Current (reading in amps X 1000)		X		X
Peak Demand (Mega Watts)				X
Present Demand (Mega Watts)				X
Energy (Mega Watt Hours)				X
Depress STEP push-button to view selected field		X		X
Depress RESET push-button to reset peak demand				X
Communications Data Available for remote use at master PC, including:				
Trip Unit IMPACC Address (set at Trip Unit)			X	X
Breaker Status (open or closed)			X	X
Reason for Status (normal, LDPU alarm, or other)			X	X
Breaker Rating Plug Installed			X	X
High Load Indication			X	X
Individual Phase Current levels (amps)			X	X
Ground Current levels (amps)			X	X
Peak Demand (Mega Watts)			X	X
Present Demand (Mega Watts)			X	X
Energy (Mega Watt Hours)			X	X

9-3. Information Available in the Event of a Trip

provides information as summarized in Table 9-2 for operator use.

In the event of a Trip, the Digitrip RMS Trip Unit

Table 9-2

Data available local to or remote from the Digitrip RMS Trip Unit during operation.	RMS 500	RMS 600	RMS 700	RMS 800
Red LEDs light to provide Trip Indication of:				
Long Delay Trip	X	X	X	X
Short Delay Trip	X	X	X	X
Instantaneous Trip	X	X	X	X
Ground Fault Trip	X	X	X	X
Discriminator/Override Trip (LS and LSG only)	X	X	X	X
Alphanumeric Digital Display Shows:				
LDT (Coded message for Long Delay Trip)		X		X
SDT (Coded message for Short Delay Trip)		X		X
INST (Coded message for Instantaneous Trip)		X		X
GNDT (Coded message for Ground Fault Trip)		X		X
DISC (Coded message for Discriminator Trip)		X		X
EXTT (Coded message for External Trip via IMPACC)				X
Phase Currents at trip (reading in amps X 1000)		X		X
Ground Current at trip (reading in amps X 1000)		X		X
Peak Demand (Mega Watts) at trip				X
Present Demand (Mega Watts)				X
Energy (Mega Watts Hours) at trip				X
Depress STEP push-button to delete coded message and view stored data as selected.		X		X
ATR contacts close for remote indication of:				
Long Delay Trip		X	X	X
Short Circuit Trip		X	X	X
Ground Fault		X	X	X
Communications data available for remote use as master PC:				
Device Address (set at Trip Unit)			X	X
Breaker Status (Trip)			X	X
Reason for Status:				
LDT (Coded message for Long Delay Trip)			X	X
SDT (Coded message for Short Delay Trip)			X	X
INST (Coded message for Instantaneous Trip)			X	X
GNDT (Coded message for Ground Fault Trip)			X	X
DISC (Coded message for Discriminator Trip)			X	X
EXTT (Coded message for External Trip via IMPACC)			X	X
Phase Currents at trip (reading in amps X 1000)			X	X
Ground Current at trip (reading in amps X 1000)			X	X
Peak Demand (Mega Watts) at trip			X	X
Present Demand (Mega Watts)			X	X
Energy (Mega Watts Hours) at trip			X	X

9-4. Resetting The Trip Unit After a Trip

Following an Overcurrent Trip, the Trip Unit is reset by depressing the TRIP RESET push-button. The Trip Unit should be reset before the Breaker is closed.

The RMS 500 Retrofit Trip Unit mode of trip LEDs are powered by the Rating Plug battery. The Breaker can be closed without resetting the Trip Unit, however the LED will remain lit until the Trip Unit TRIP RESET push-button is depressed. Resetting the Trip Unit in a timely manner saves on battery life. In new condition the battery will power the LED for approximately 60 hours.

The RMS 600, 700 & 800 Retrofits have provisions for an external 120 Vac source connected through the External Harness. If the 120 Vac source is ON, the Breaker will be held in the Trip Free Condition (cannot be closed) by the Direct Trip Actuator (DTA) until the Trip Unit TRIP RESET push-button is depressed. The Trip Unit mode of trip LEDs are powered by the external 120 Vac source, and backed up by the battery in the Rating Plug. If the external 120 Vac source to the Trip Unit is lost, the Trip Unit acts as described for the RMS 500.

The RMS 700 & 800 Retrofits have communications capability, which permit opening and (for electrically operated Breakers) closing via IMPACC. In the event of an Overcurrent Trip, the Trip Unit will act as described, requiring local resetting of the Trip Unit before the Breaker can be closed. However, if the Breaker is tripped remotely via IMPACC (alphanumeric coded message EXTT), it can be closed via IMPACC without local resetting at the Trip Unit.

Digitrip RMS Trip Units provided without Instantaneous Protection, i.e. LS or LSG, are equipped with a nonadjustable discriminator and instantaneous override circuit. The Discriminator Circuit prevents the Circuit Breaker from being closed and latched-in on a fault. The nonadjustable release is preset at 11 times the installed Rating Plug I_n rating. When the Breaker trips due to the Discriminator/Override, the Discriminator/Override red LED will light.

9-5. Removing The Breaker From the CONNECT Position

RMS 500 Basic Retrofitted Breakers include no External Harness and require no special procedures (other than those normally observed) for removing the Breaker from the CONNECT position in the Switchgear Cell.

RMS 500 Zone, 600, 700 & 800 Retrofitted Kits are equipped with the External Harness. Care must be observed to disconnect the External Harness Plug from the Switchgear Cell Harness Assembly, when removing the Breaker from the CONNECT position.

NOTE: If the Cell Terminal Block, Wiring Harness, and Plug Assembly is properly positioned in the Switchgear Cell with respect to the Breaker, the Breaker can be withdrawn to the TEST position with the External Harness plugged in. However, to withdraw the Breaker completely from the cell, the External Harness must be disconnected.

CAUTION

FAILURE TO DISCONNECT THE EXTERNAL HARNESS FROM THE CELL HARNESS ASSEMBLY IN THE SWITCHGEAR CELL COULD CAUSE PHYSICAL DAMAGE TO THE EQUIPMENT.

Section 10

Digitrip RMS Retrofit Switchgear Assembly Applications

10.1 Zone Interlocking

All Digitrip RMS Trip Units include provisions for Zone Interlocking connection of the Trip Unit short time (S) and Ground Fault (G) delay protective functions. If Zone Interlocking is not required, it must be defeated by shorting out the appropriate terminals.

NOTICE: *Digitrip RMS Zone Interlocking will trip the Breaker instantaneously on Short Time (S) or Ground Fault (G) delay trip functions unless it is defeated as described herein.*

For RMS 500 Basic retrofit Kits, Zone Interlock functions are not wired out from the Trip Unit. The External Harness provided consists of a small jumper plug that shorts out the Zone Interlock signals at the Trip Unit.

For RMS 500 Zone, 600, 700 & 800 Retrofit Kits, Zone Interlock functions are extracted from Trip Unit Plug J2 by the Breaker External Harness as shown in Figure 5-3. The Breaker External Harness plugs into the Cell Harness Assembly. The Terminal Cell Harness includes provisions for external wiring connections as shown in Figure 5-1. Shorting jumpers (S_{IN}-S_{OUT} and G_{IN}-G_{OUT}) are provided at the Terminal Block Assembly to defeat the Zone Interlock functions. These jumpers can be removed and selective zone interlocking schemes applied. Typical connection schemes for multiple Circuit Breakers are shown in Figures 10-1 and 10-2.

10-2. The Power Relay Module (ATR)

RMS 600, 700 & 800 Retrofit Kits include the Power Relay Module (ATR), which is mounted integral to the RMS/R Trip Unit. The ATR input and output signals are extracted from the Trip Unit Plug J4 through the External Harness as shown in Figure 6-3. The Breaker External Harness plugs to the Cell Harness Assembly, which includes provisions for external wiring connections as shown in Figure 6-1. Figure 10-3 shows typical ATR 120 Vac source input and dry contact alarm output connections for remote alarm indication.

10-3. Communications and IMPACC

RMS 700 & 800 Retrofit Kits include communications capability when used with Cutler-Hammer Integrated Monitoring Protection and Control Communications

(IMPACC) System. Each RMS/R Trip Unit includes an Integrated Communications Chip that permits the extraction of Trip Unit data and the implementation of Breaker close and trip commands from a remote master computer. Communications is accomplished from the Trip Unit to the master computer via radio frequency signal over a twisted pair communications network. The communications signal (COMM1 and COMM2) are extracted from Trip Unit Plug J3 through the External Harness as shown in Figure 7-1 and 7-4. The Breaker External Harness plugs to the Cell Harness Assembly, which includes provisions for external wiring connections as shown in Figure 7-2.

Typical ONCOM network communication schemes are shown in Figures 10-4 through 10-6. For a simple pre-engineered network system, the following rules apply:

Rule 1: Up to 5 "main runs" may be connected to the system master computer. Each run may be a maximum of 7500 feet in length from the computer to the farthest addressable device.

Rule 2: A 150 ohm, 0.50 watt "end-of-line" resistor must be placed at the end of each main run at the farthest addressable device. This resistor properly balances the network impedance to reduce the potential for standing waves. For RMS 700 & 800 Retrofit Kits, this resistor is attached to TB3-3 (COMM1) and TB3-4 (COMM2) of the Cell Harness Terminal blocks. (See Figure 7-2)

Rule 3: An unlimited number of "tees" (maximum length 200 feet) can be added to each "main run." No "end-of-line" resistor is required at the end of the "tee." "Tees" must be connected in parallel to the "main run."

Rule 4: If a "main run" or "tee" terminates at its end to an Assemblies Electronic Monitor (AEM) equipped with a Time Stamp Filter (TSF), the communications network can be extended another 7500 feet. The AEM can accommodate a maximum of 40 Digitrip RMS 700 or 800 Trip Units and 8 IQ Data Plus II devices. An "end-of-line" resistor is required at the farthest device on the extended line.

Rule 5: Use of #18 AWG shielded cable is recommended where radio frequency interference of IMPACC with other circuits is possible. The cable shielding serves to prevent the IMPACC signals from such interference.

Legend:
 TB1-1 DG – Digital Ground
 TB1-2 G_{OUT} – Ground Out
 TB1-2 G_{IN} – Ground In

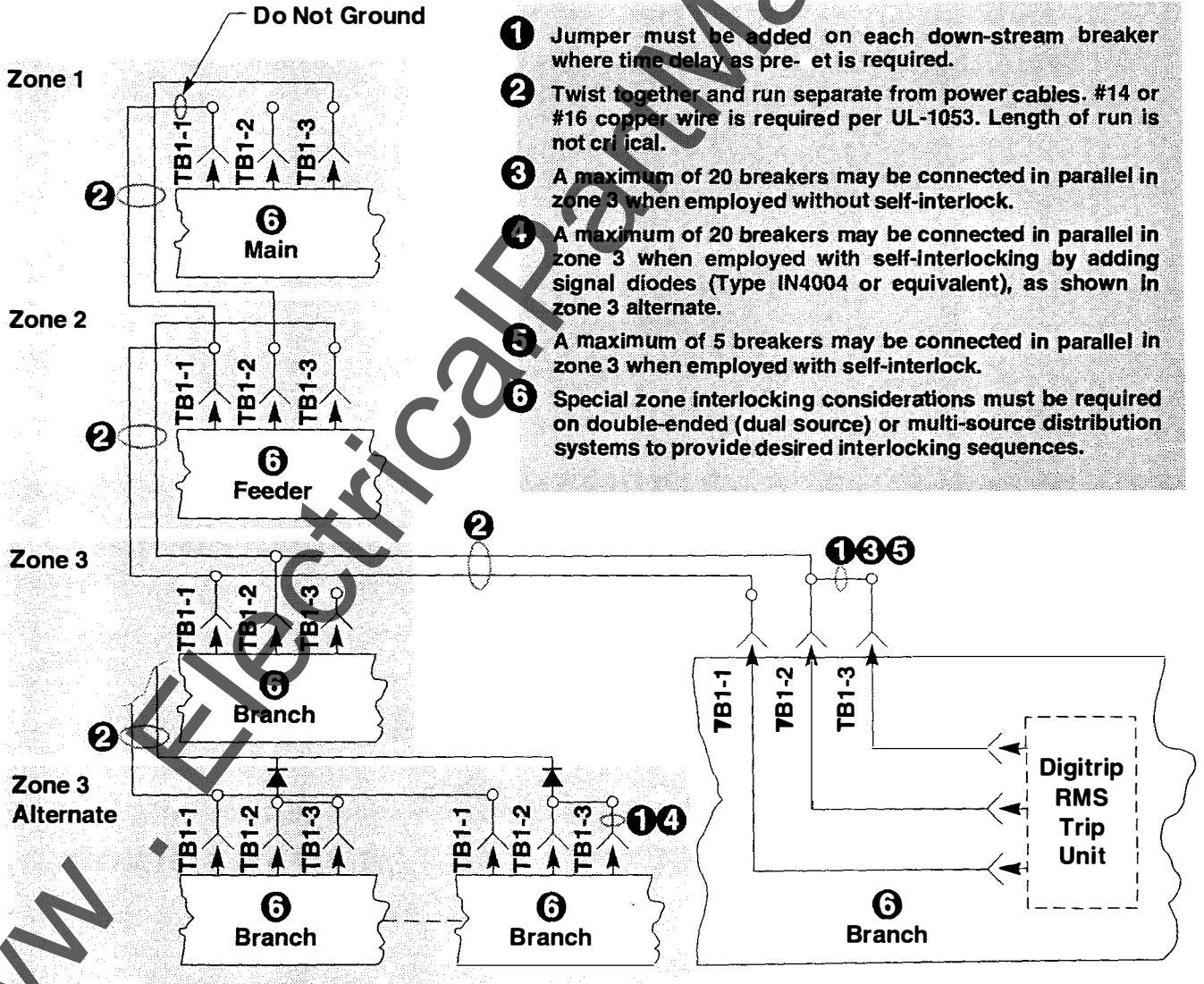
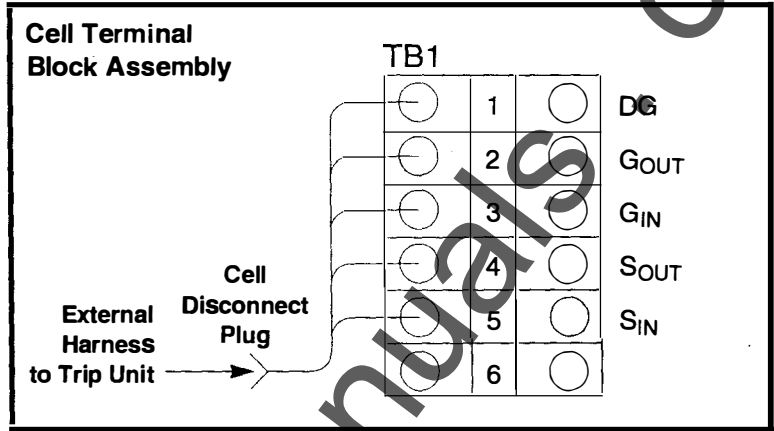

Figure 10-1

Legend:
 TB1-1 DG - Digital Ground
 TB1-4 S_{OUT} - Short Delay Out
 TB1-5 S_{IN} - Short Delay In

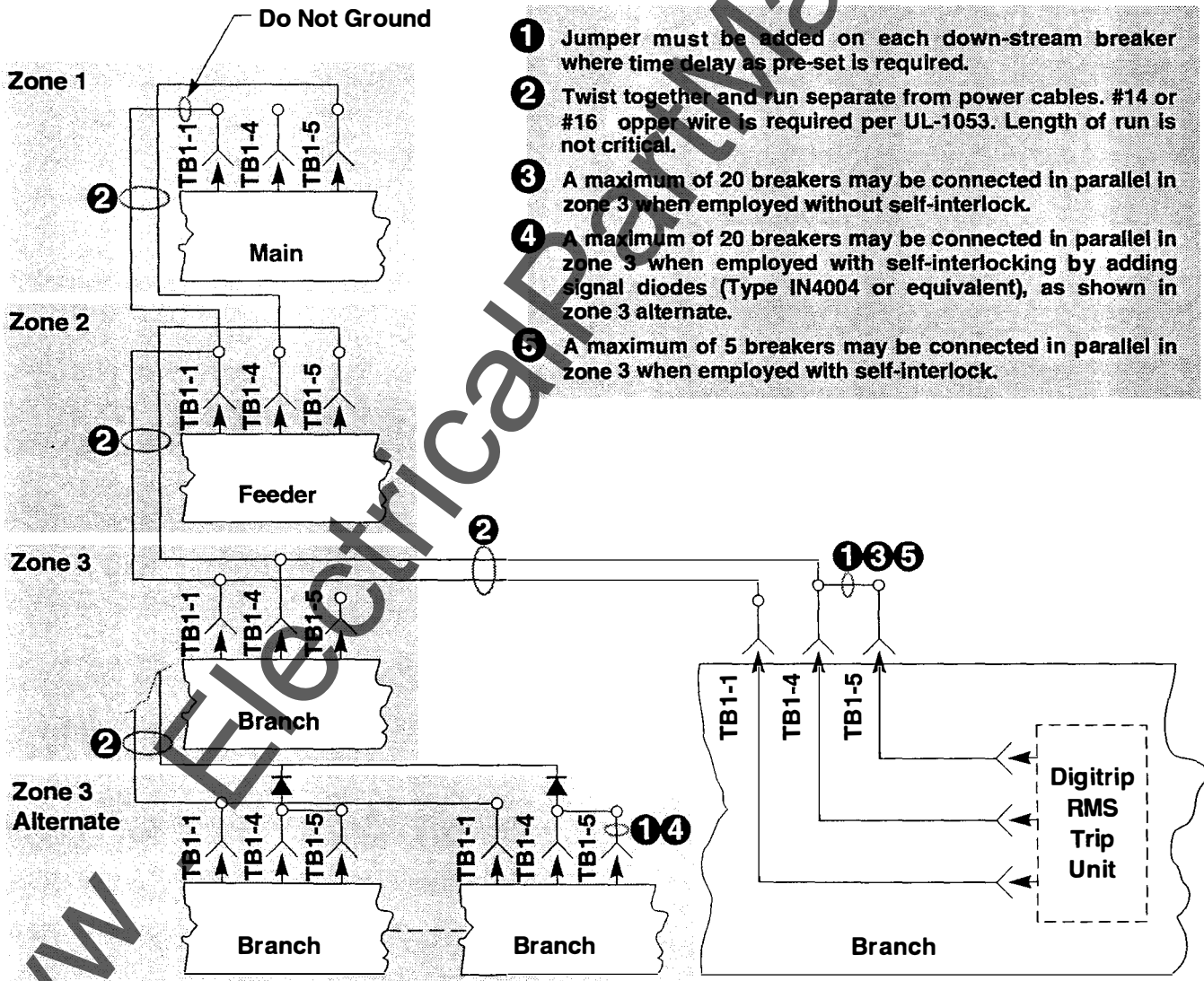
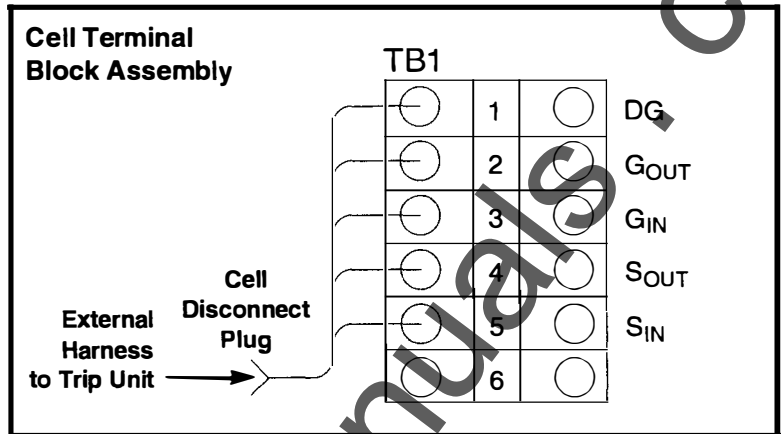

Figure 10-2

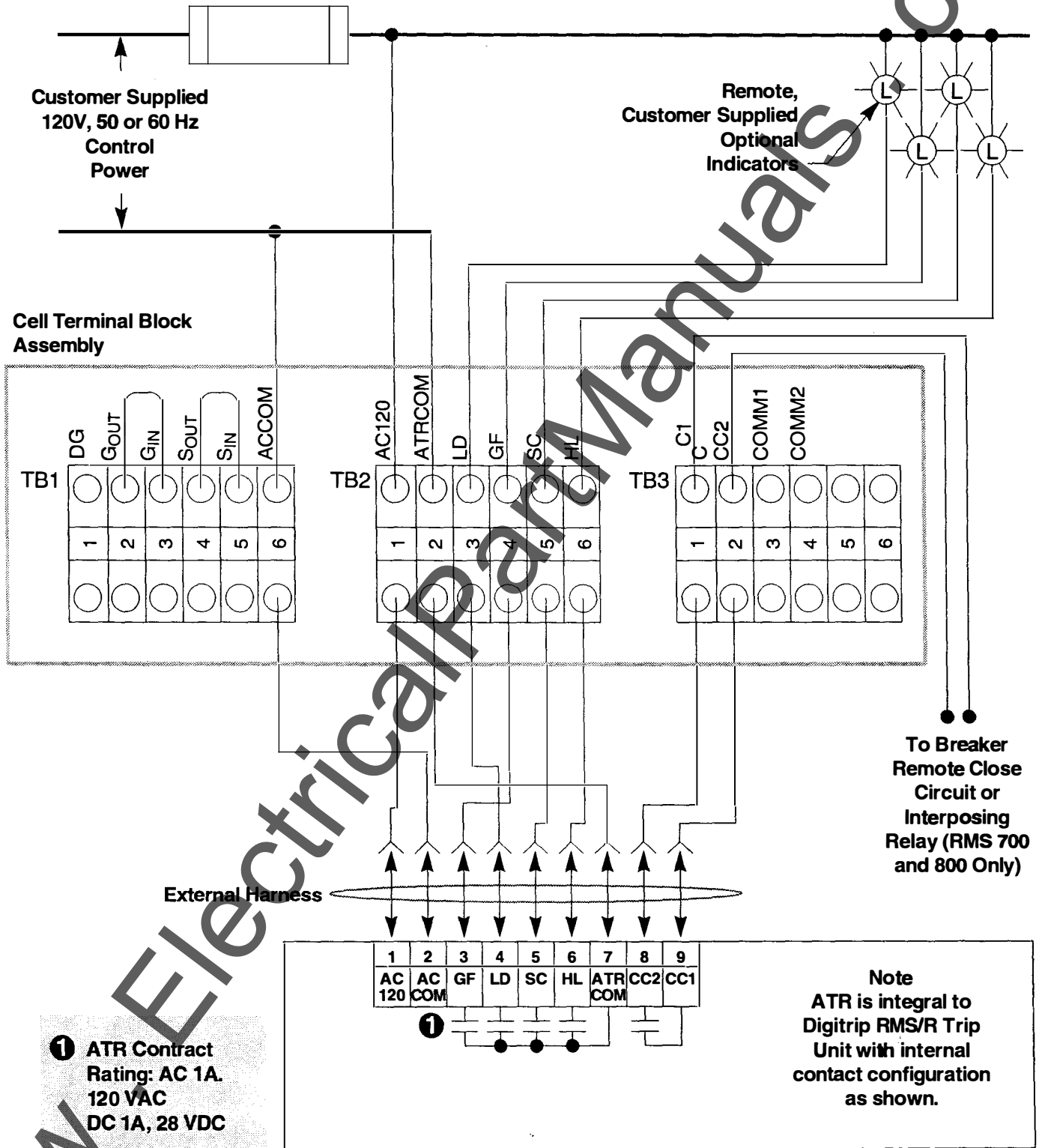
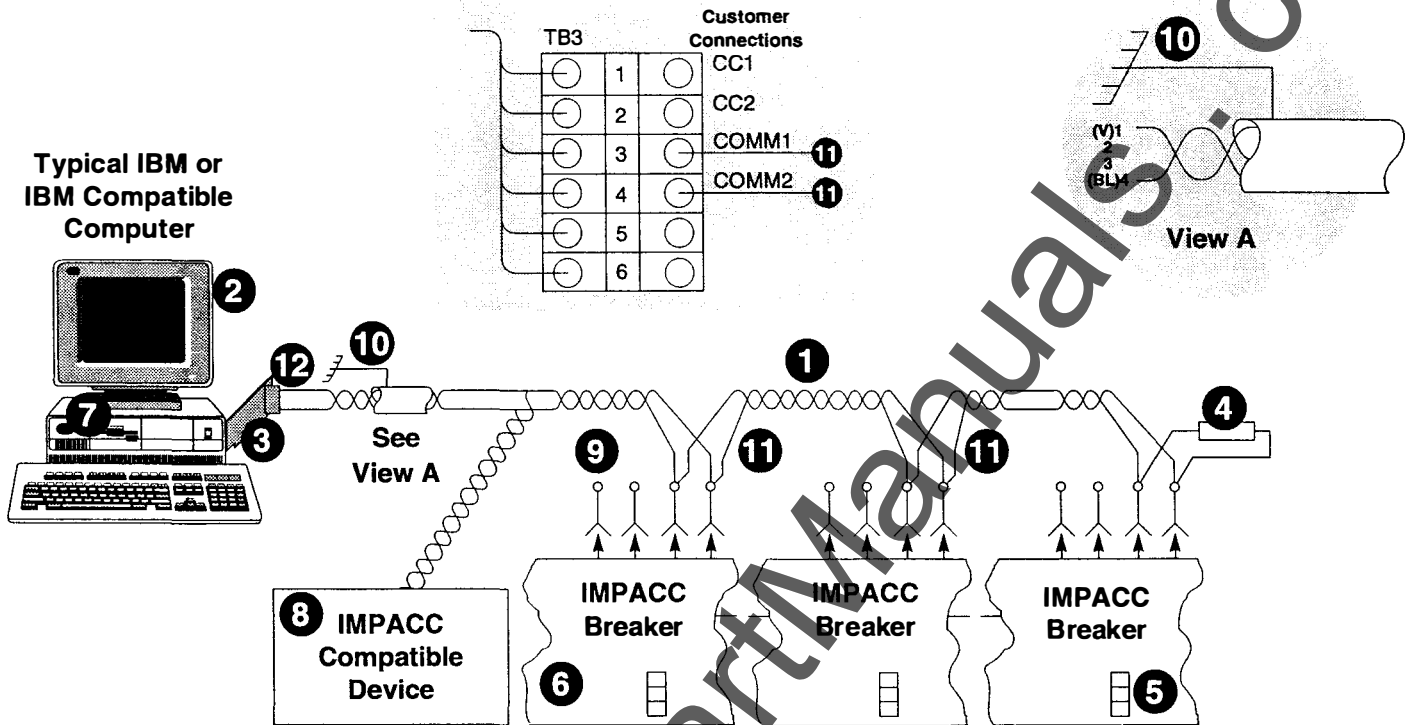
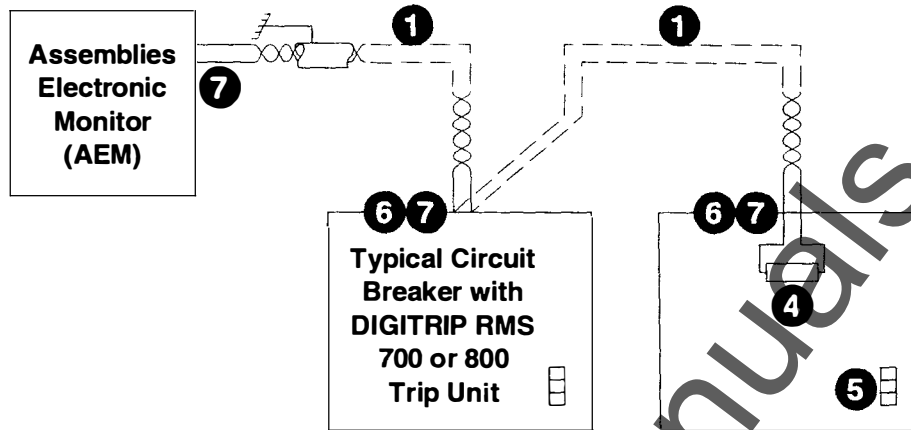

Figure 10-3



- 1 For network interconnections use twisted pair conductors (No. 18 AWG shielded preferred).
- 2 For the master device, use an IBM or equivalent (compatible) personal computer.
- 3 A Cutler-Hammer CONI (Computer Operated Network Interface) card must be inserted into the computer frame.
- 4 A 150 ohm (1/2 watt) carbon composition resistor must be installed on the most remote Circuit Breaker Cell Harness terminals, as shown, where distance from master exceeds 500 feet.
- 5 A 3-digit INCOM address must be present on each Trip Unit. Each IMPACC address must be unique in the system. For instructions, refer to I.L. 29-853 or I.L. 29-854.
- 6 For Retrofit Kits, all connections at the Cell Terminal Block Assembly.
- 7 For application software, contact Cutler-Hammer at 1-800-937-5487.
- 8 Can be connected to other IMPACC compatible devices. See I.L. 29-853 and I.L. 29-854.
- 9 120 Vac incoming power connections at terminals "AC120" and "ACCOM."
- 10 Ground shielding as shown.
- 11 Where devices are daisy chained, interconnect shielding, IMPACC connections at "COMM1" and "COMM2."
- 12 Modular telephone connector, type RJ11, supplied by user.

Figure 10-4



- 1 For network interconnections use twisted pair conductors (No. 18 AWG shielded preferred).
- 2 For the master device, use an IBM or equivalent (compatible) personal computer.
- 3 A Cutler-Hammer CONI (Computer Operated Network Interface) card must be inserted into the computer frame.
- 4 A 150 ohm (1/2 watt) carbon composition resis or must be installed on the most remote Circuit Breaker Cell Harness terminals, as shown.
- 5 A 3-digit INCOM address must be present on each Trip Unit. Each IMPACC address must be unique in the system. For instructions, refer to I.L. 29-853 or I.L. 29-854.
- 6 Refer to Circuit Braker connection diagrams referenced in Figure 10-4 for actual connection.
- 7 Ground shielding as shown. Where devices are daisy chained, interconnect shielding.
- 8 Modular telephone connector type RJ11, suppl ed by user and wired per View A as required by CONI card.

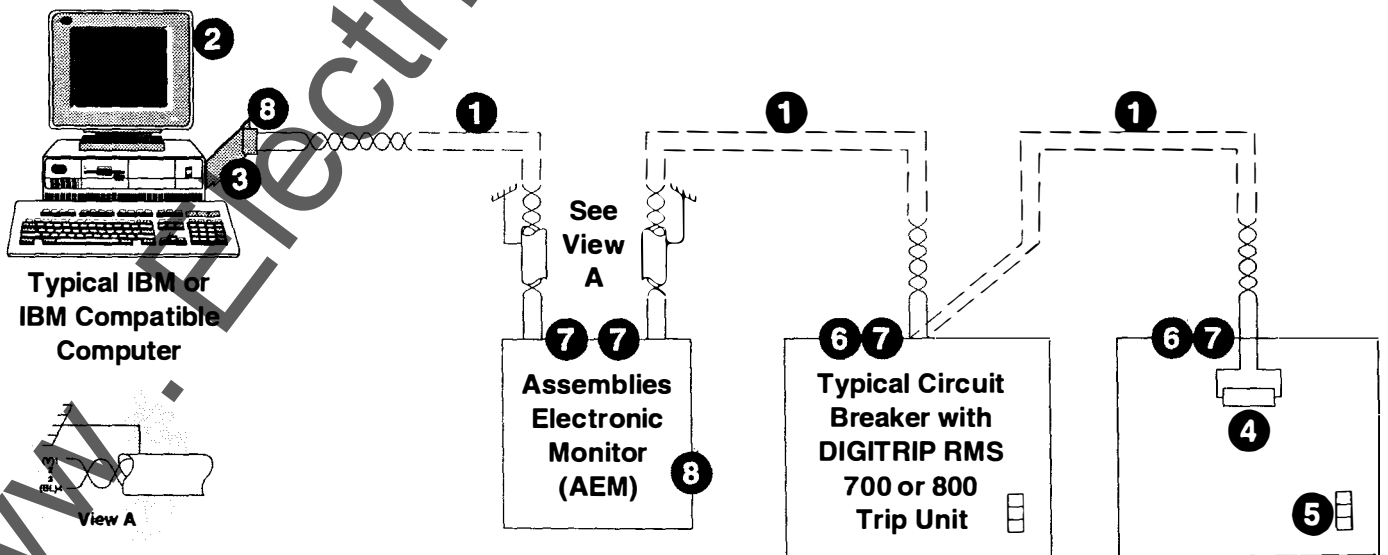
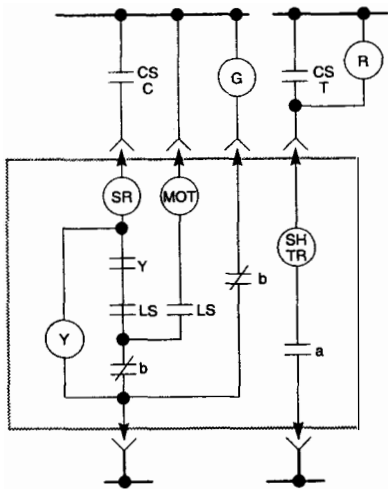
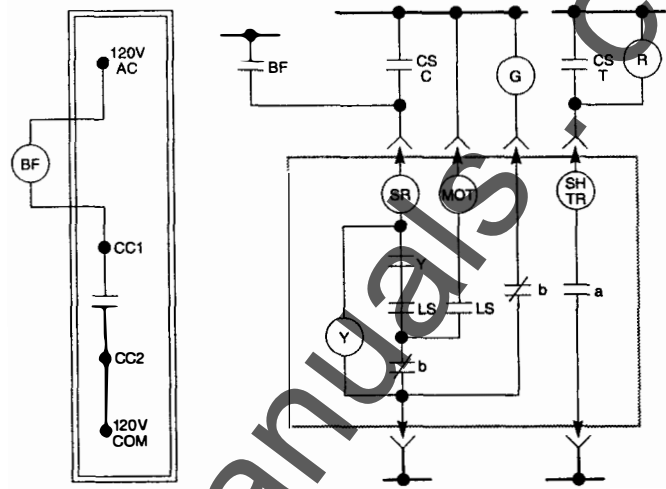

Figure 10-5 (Top) and 10-6 (Bottom)



A. Typical Control Schematic Without CC1/CC2 Modification



Cell terminal block assy.
6502C71G03 or 6503C57G03
Note: Mount "BF" relay or equivalent, in cell near cell terminal block assy.

B. CC1/CC2 Modification to a Typical Control Schematic (Stored Energy)

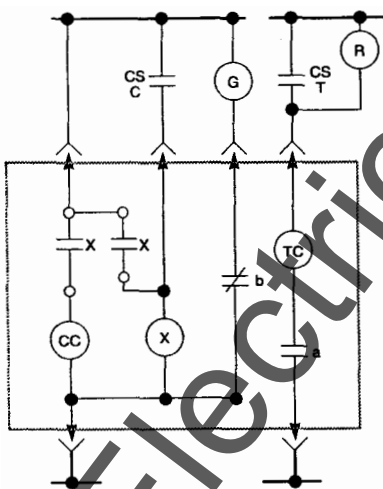

C. Typical Control Schematic Without CC1/CC2 Modification

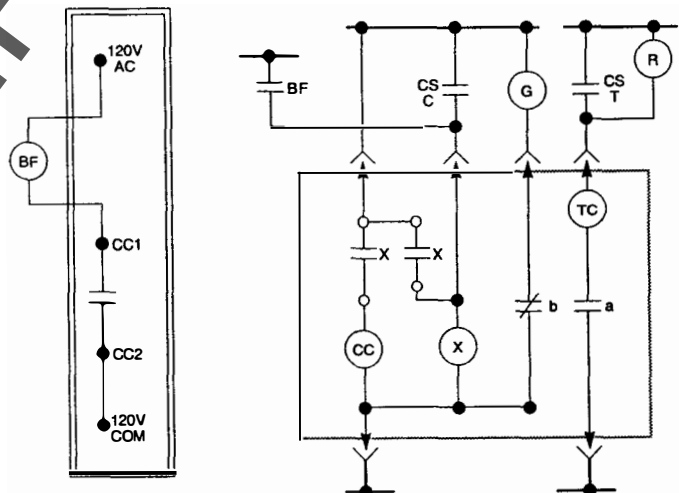

Cell terminal block assy.
6502C71G03 or 6503C57G03
Note: Mount "BF" relay or equivalent, in cell near cell terminal block assy.

D. CC1/CC2 Modification to a Typical Control Schematic (Solenoid)

Figure 10-7 A, B, C, D

Section 11

Maintenance, Warranty, and Service Information

11-1. Preventative Maintenance Program

A periodic maintenance program is essential to assure Breaker and Switchgear reliability and integrity. Periodic maintenance, including testing, inspection, adjustment, and repair should be performed on both the Circuit Breaker and the Switchgear Assembly. For normal operating conditions, a minimum periodic interval of 12 months is recommended. However, additional factors, such as equipment age, state of repair, general condition, local operating environment, number of annual cycles, etc. must be considered in determining an effective maintenance interval.

11-2. Breaker Maintenance

Installation of a Digitrip RMS Retrofit Kit on an existing Circuit Breaker does not alleviate the user from maintaining the Circuit Breaker in good operating condition. The Digitrip RMS Trip System will greatly enhance the capability of the Circuit Breaker to reliably and accurately detect and initiate a trip in the event of an overcurrent condition or fault. However, the ability of the Breaker to trip and clear the fault is directly dependent on the operating condition of the Breaker.

The user should continue to follow the applicable instructions and procedures provided by the Breaker manufacturer and incorporate them into a periodic preventative maintenance program. The following items are not all inclusive, but should be an integral part of such a program:

1. *Cleanliness:* Breaker moving parts, insulation, and current carrying parts should be kept clean from dust, dirt, and sludge.
2. *Lubrication:* The Breaker operating mechanism should open (trip) and close properly and not stick, bind, or jam. The Breaker should be lubricated as required according to the manufacturer's recommendations.

3. *Contact Condition and Adjustment:* Breaker moving and stationary arcing and main contacts should be in proper adjustment, in good condition, and free from burning and pitting. Breaker primary and secondary disconnecting contacts should be in good condition.
4. *General Condition and Repair:* Breaker hardware should be tight and retaining rings intact. Worn out parts should be replaced or repaired. Electrical connections and wire insulation should be sound and free from evidence of overheating.
5. *Digitrip RMS Trip System:* Section 8 provides recommended testing procedures for Digitrip RMS Trip System.

11-3. Warranty Procedure

Digitrip RMS Retrofit Kits include a limited warranty for components for one (1) year from the date of shipment. In the event of a warranty problem with a Retrofit Kit component contact Cutler-Hammer by the channel through which the Retrofit Kit was purchased. Contact the Cutler-Hammer Retrofit Kit distributor, representative, or installer (as applicable) and provide the following information:

1. Original order number by which the Kit component was purchased.
2. Part description.
3. Part catalog and/or style number.
4. Complete description of the problem.

If the problem is covered under warranty, instructions will be provided for obtaining a component replacement or for returning the component for repair.

11-4. Digitrip RMS Trip Unit Warranty

Digitrip RMS Trip Units are factory sealed and are not field serviceable. Breaking the factory seal, opening the Trip Unit, and tampering with its internal components will void any warranty. In the event of a problem with the Trip Unit, contact your local Cutler-Hammer representative per the instructions provided in 11.3 above.

Section 12

Detailed Wiring Common to all Digitrip RMR/R Kits

12.1 Sensor Harness and CT Harness Wiring

To cover both 3 and 4 wire system applications, the Sensor Harness includes two wires to permit the 4th wire connection. These two wires (one tan and one green) are readily identifiable; they are the longest two wires that protrude from the Sensor end of the harness. Determine the applicable wiring diagram (Figure 12-1, 12-2, 12-3, 12-4) for your application, and perform the following:

1. If the retrofit is for a 3-wire system (Figure 12-1 or 12-2) the wires provided for the fourth wire connection are not needed. Remove the terminals from the long ends of the green and tan wires, then use the ohmmeter to confirm the other ends and remove them by sliding them out of the harness.
2. If the retrofit is for a 4-wire system (Figure 12-3 or 12-4) the green and tan wires provided for the fourth connection are required for connection to an open set of Breaker secondary contacts.

Note: For 4-wire grounded systems, the Breaker and Cell Secondary Contacts (if required) and the 4th Sensor for the Switchgear neutral are not included in the Kit contents. These items must be ordered separately from the Kits.

12.2 Auxiliary CT Harness Wiring

Figure 12-5 shows the detailed wiring connections for the Auxiliary CT Harness.

12.3 Auxiliary CT Module Wiring

Figure 12-6 shows the detailed wiring for the Auxiliary CT Modules.

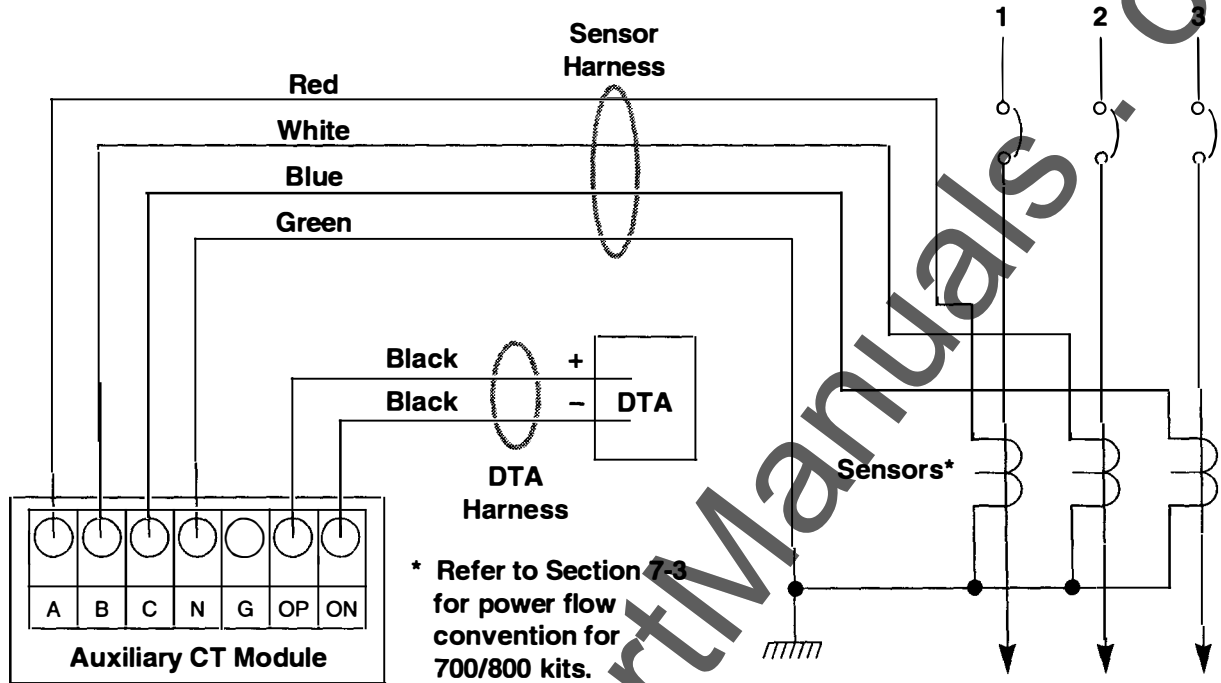

Figure 12-1 Without Ground 3Ø 3-Wire (LI, LS, LSI)

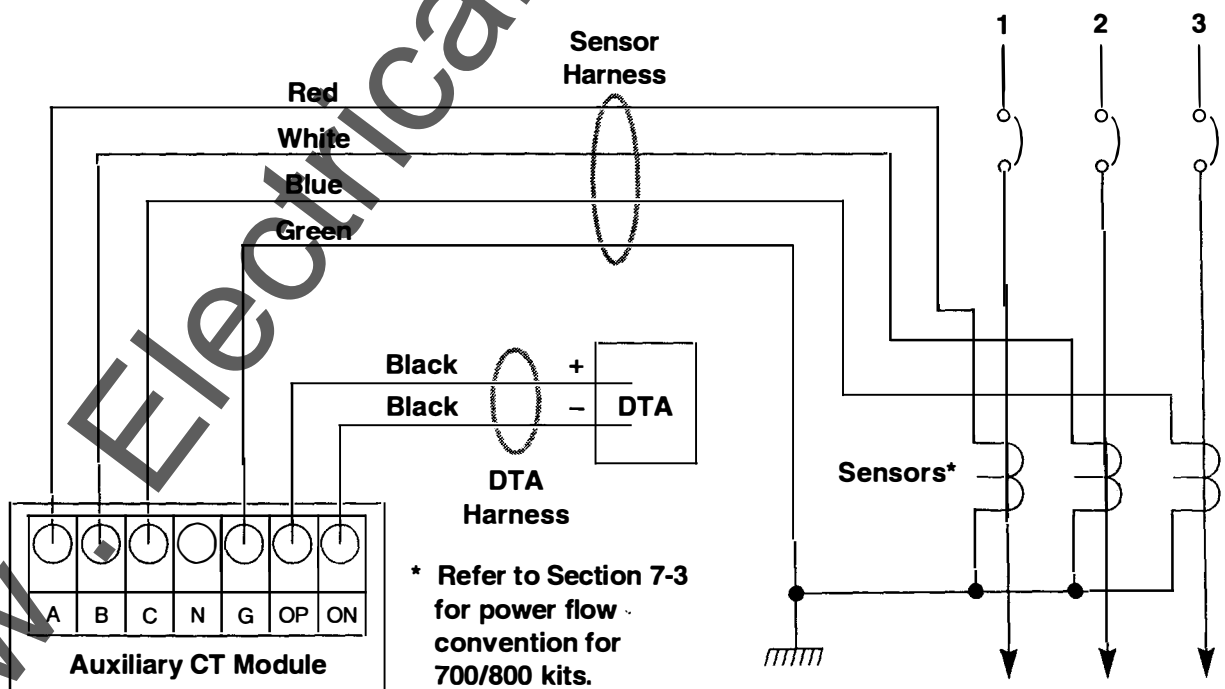

Figure 12-2 With Ground, Without Neutral Connection 3Ø 3-Wire (LIG, LSG, LSIG)

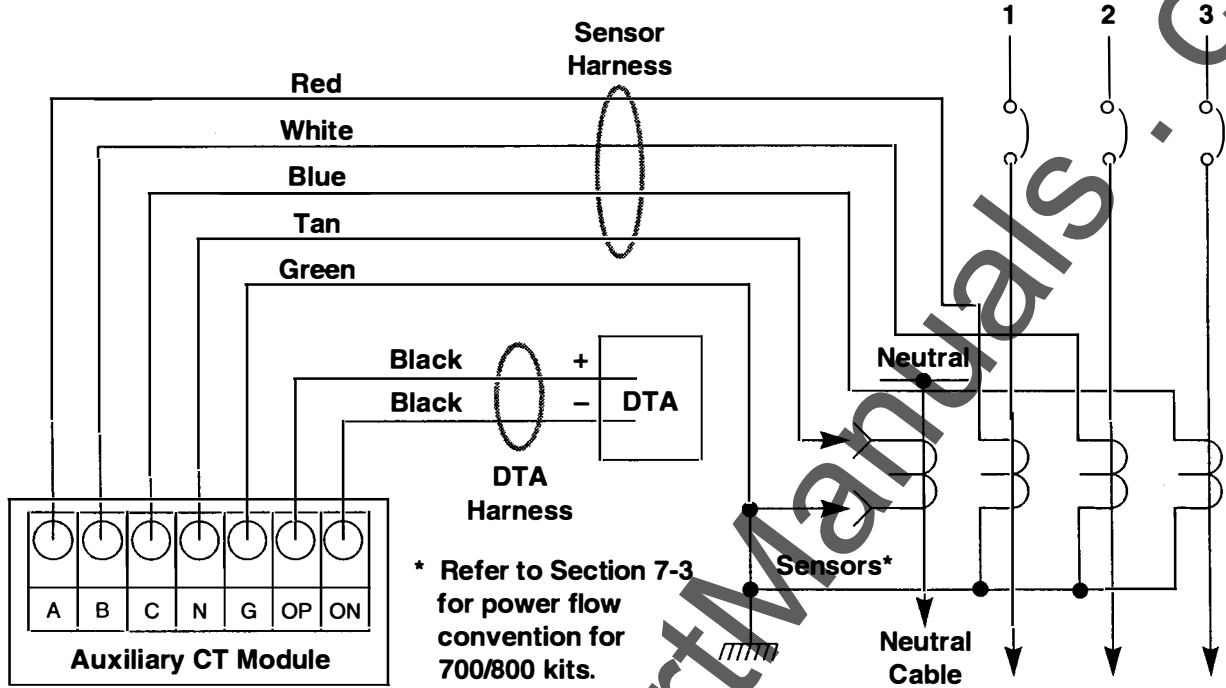

Figure 12-3 With Ground and With Neutral Sensor 3Ø 4-Wire (LIG, LSG, LSIG)

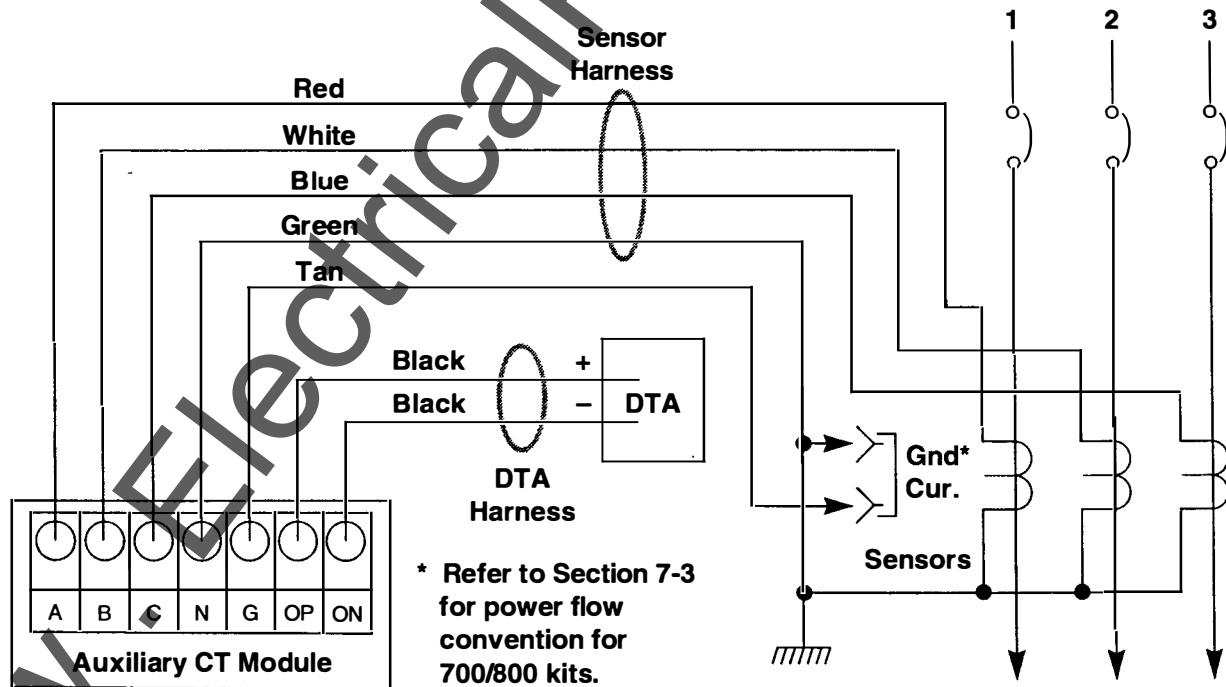

Figure 12-4 With Ground, With External Ground Source 3Ø 3-Wire or 4-Wire (LIG, LSG, LSIG)

**AUX. CT HARNESS
EXTERNAL HARNESS
STYLE NO. 6502C84G01
6502C84G02**

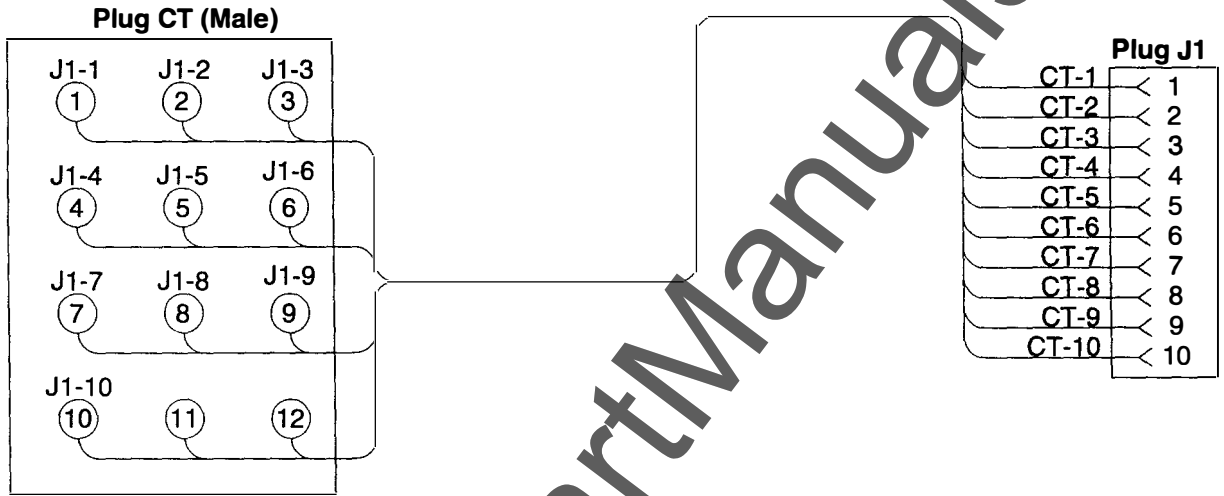

Figure 12-5 Auxiliary CT Harness

Style Numbers: 6502C78G02, 6503C59G02 (With Ground);
6502C78G01, 6503C59G01 (Without Ground)

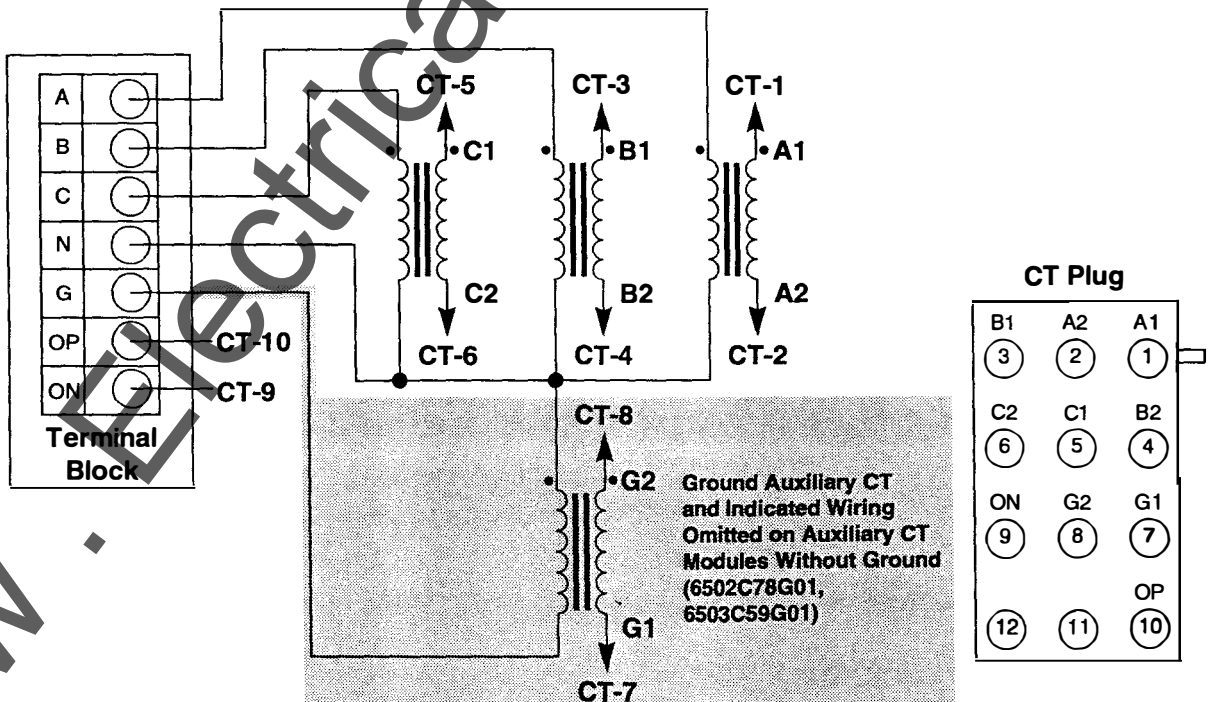

Figure 12-6 Auxiliary CT Module Wiring

Section 13 References

The listed documents are available references applicable to your Digitrip RMS Retrofit Kit installation.

- I.L. 29-851 Instructions for Digitrip RMS 500 Trip Units
- I.L. 29-852 Instructions for Digitrip RMS 600 Trip Units
- I.L. 29-853 Instructions for Digitrip RMS 700 Trip Units
- I.L. 29-854 Instructions for Digitrip RMS 800 Trip Units

The instruction leaflets listed for Digitrip RMS Trip Units provide useful descriptive information that is also applicable to the Digitrip RMS/R.

This Application Data is used in conjunction with the Installation Literature for your particular Breaker application. A wide variety of Kits are available and new Breaker applications are an ongoing development effort. Contact Cutler-Hammer for the latest available Retrofit Kits.

Section 14

Explanation of Time Current Curves

14-1. Explanation of the Time Current Curves (LSI)

Digitrip RMS Trip Units and Digitrip Retrofit Kits have been designed to upgrade existing Breakers to meet the same protection requirements of the most modern Power Circuit Breakers. In fact the Trip Unit and DTA (Direct Trip Actuator) are electrically identical to those found on current DS Breakers, and they are built in the same manufacturing facilities, with the same high level of Quality Control, as those on the DS Breakers. In this way we assure that the retrofit designs are as up to date as our current production.

All Digitrip RMS Trip Units are designed to meet the protection requirements of a modern power distribution system. As is shown in Figure 14-1, Application Current Levels can be broken into three typical regions:

- NORMAL currents, the magnitude of which is within the system continuous current rating.
- OVERLOAD currents, which exceed the system continuous current rating and where conductor heating is the primary concern (such as with an overloaded motor, for example).
- FAULT currents, which are usually caused by an unintended current path (either phase to phase or phase to ground) and can lead to currents as high as the maximum short circuit available from the system.

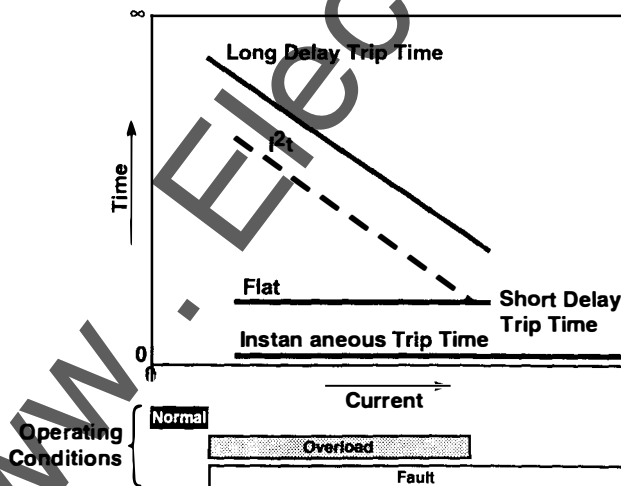

Figure 14-1 Time-Current Curves

Digitrip RMS Trip Units, when set up according to the results of a Power System study of the specific distribution system on which they are applied, will respond to various current levels to provide accurate system protection as well as maximum system stability by properly coordinating with upstream and downstream devices. Again referring to Figure 14-1:

- For NORMAL currents, the Trip Unit will accurately monitor the current, regardless of current waveform (due to its true RMS sensing system), assuring that up to full rated current may flow through the system without falsely tripping the breaker. This is shown as the NORMAL OPERATING CONDITION in Figure 14-1.
- For OVERLOAD currents, the Trip Unit will accurately assess the true heating value of the current (again a distinct advantage of its true RMS sensing system), and trip out following the LONG DELAY TRIP TIME curve in Figure 14-1. There are actually eight different LONG DELAY TRIP TIME curves available on the trip unit (selected by the Long Delay Time switch setting), and each curve follows a constant I^2t slope for excellent heating protection and coordination with other devices. The lowest level of OVERLOAD current to bring on this response is selected by the Long Delay Pickup setting on the Trip Unit (see Sections 14-2 through 14-4 for more information, including tolerances).
- For FAULT currents, the Trip Unit will respond according to either the SHORT DELAY TRIP TIME or the INSTANTANEOUS TRIP TIME shown in Figure 14-1, depending on the fault current magnitude and whether the Short Delay function or Instantaneous function or both are present on the Trip Unit.
- In most applications, main Breakers will have Long Delay and Short Delay functions, but will omit the Instantaneous function to allow a downstream feeder Breaker to clear the fault without tripping the main Breaker, thereby enhancing system stability.

- In many applications, feeder Breakers will have Long Delay, Short Delay and Instantaneous functions to allow a downstream device to clear the fault without tripping the feeder or the main Breaker, thereby maximizing system stability.
- In some applications, feeder Breakers will have Long Delay and Instantaneous functions, but omit the Short Delay function. This is fine for coordination with upstream main Breakers, but the feeder would not normally allow a downstream device to clear the fault without tripping the feeder, thereby compromising the system stability.
- In some applications, feeder breakers will have Long Delay and Short Delay functions, but will omit the Instantaneous function to allow proper operation of an unusual load or coordination with downstream devices.

The SHORT DELAY TRIP TIME curve in Figure 14-1 shows the time to trip response of the Trip Unit to FAULT currents. There are actually eight different SHORT DELAY TRIP TIME curves available on the Trip Unit (selected by the Short Time switch setting), three of which follow a constant I^2t slope for best coordination with downstream devices, five of which are FLAT (fixed trip time). The lowest level of FAULT current to bring on this response is selected by the Short Delay Pickup setting on the trip unit (see Sections 14-2 through 14-4 for more information, including tolerances).

The SHORT DELAY TRIP TIME curves available on the Trip Unit (selected by the Short Time switch setting), can also be modified by a feature of the Digitrip RMS system called ZONE SELECTIVE INTERLOCKING. This feature is provided to allow a more flexible coordination system. For example this feature, when used on both a main and its feeder Breakers, will change the feeder Breaker SHORT DELAY TRIP TIME curve to its fastest flat level if both the main and the feeder are in the SHORT DELAY mode concurrently. (see Sections 10-1 and 14-2 through 14-4 for more information, including tolerances).

The INSTANTANEOUS TRIP TIME curve in Figure 14-1 shows the time to trip response of the Trip Unit to FAULT currents. This curve is FLAT, providing the most rapid trip time possible (with no intentional delay) to be able to clear the fault as fast as possible and minimize the damage to the system. The lowest level of FAULT current to bring on this response is selected by the Instantaneous Pickup setting on the Trip Unit (see Sections 14-2 through 14-4 for more information, including tolerances).

14-2. Explanation of Time-Current Tables (LSI)

The time-current curves shown in Figures 3-1 and 3-2 accurately describe the response of the Digitrip RMS Retrofit Kit Trip System to all relevant levels of current and Trip Unit protection function switch settings, but they are sometimes difficult to interpret for specific combinations of Rating Plugs and switch settings. The purpose of this section is to provide an alternative method for determining the trip system response based on lookup tables rather than curves.

The trip system response to current flowing through the Breaker can be determined by a simple two step process:

1. Identifying which timing band corresponds to the Breaker Current.
2. Identifying the trip time corresponding to the Breaker current and the timing tolerance band.

Tables 14-1 and 14-2 assist in identifying which timing band corresponds to the Breaker Current. Information required to use these tables is:

- Rating Plug Rating (I_n) Tables 14-1, 14-2
- Long Delay Pickup switch setting Table 14-1
- *Short Delay Pickup switch setting Table 14-2
- *Instantaneous Pickup switch setting Table 14-2

* (Your Trip Unit may have one or both of these switches, depending on the protection functions supplied).



Table 14-1
Long Delay Pick-up Currents

Plug Rating (I _n)	Minimum = -0%; Maximum = +10% Tolerance							
	0.50	0.60	0.70	0.80	0.85	0.90	0.95	1.00
100	50	60	70	80	85	90	95	100
	55	66	77	88	94	99	105	110
200	100	120	140	160	170	180	190	200
	110	132	154	176	187	198	209	220
250	125	150	175	200	213	225	238	250
	138	165	193	220	234	248	261	275
300	150	180	210	240	255	270	285	300
	165	198	231	264	281	297	314	330
400	200	240	280	320	340	360	380	400
	220	264	308	352	374	396	418	440
600	300	360	420	480	510	540	570	600
	330	396	462	528	561	594	627	660
800	400	480	560	640	680	720	760	800
	440	528	616	704	748	792	836	880
1000	500	600	700	800	850	900	950	1000
	550	660	770	880	935	990	1045	1100
1200	600	720	840	960	1020	1080	1140	1200
	660	792	924	1056	1122	1188	1254	1320
1600	800	960	1120	1280	1360	1440	1520	1600
	880	1056	1232	1408	1496	1584	1672	1760
2000	1000	1200	1400	1600	1700	1800	1900	2000
	1100	1320	1540	1760	1870	1980	2090	2200
2500	1250	1500	1750	2000	2125	2250	2375	2500
	1375	1650	1925	2200	2338	2475	2613	2750
3000	1500	1800	2100	2400	2550	2700	2850	3000
	1650	1980	2310	2640	2805	2970	3135	3300
3200	1600	1920	2240	2560	2720	2880	3040	3200
	1760	2112	2464	2816	2992	3168	3344	3520
4000	2000	2400	2800	3200	3400	3600	3800	4000
	2200	2640	3080	3520	3740	3960	4180	4400

Table 14-2
Short Delay and Instantaneous Pick-up Currents

Plug Rating (I _n)	Minimum = -10%; Maximum = +10% Tolerance									
	2.0	2.5	3.0	4.0	5.0	6.0	8.0	10.0	12.0	
100	180	225	270	360	450	540	720	900	1080	
	220	275	330	440	550	660	880	1100	1320	
200	360	450	540	720	900	1080	1440	1800	2160	
	440	550	660	880	1100	1320	1760	2200	2640	
250	450	563	675	900	1125	1350	1800	2250	2700	
	550	688	825	1100	1375	1650	2200	2750	3300	
300	540	675	810	1080	1350	1620	2160	2700	3240	
	660	825	990	1320	1650	1980	2640	3300	3960	
400	720	900	1080	1440	1800	2160	2880	3600	4320	
	880	1100	1320	1760	2200	2640	3520	4400	5280	
600	1080	1350	1620	2160	2700	3240	4320	5400	6480	
	1320	1650	1980	2640	3300	3960	5280	6600	7920	
800	1440	1800	2160	2880	3600	4320	5760	7200	8640	
	1760	2200	2640	3520	4400	5280	7040	8800	10560	
1000	1800	2250	2700	3600	4500	5400	7200	9000	10800	
	2200	2750	3300	4400	5500	6600	8800	11000	13200	
1200	2160	2700	3240	4320	5400	6480	8640	10800	12960	
	2640	3300	3960	5280	6600	7920	10560	13200	15840	
1600	2880	3600	4320	5760	7200	8640	11520	14400	17280	
	3520	4400	5280	7040	8800	10560	14080	17600	21120	
2000	3600	4500	5400	7200	9000	10800	14400	18000	21600	
	4400	5500	6600	8800	11000	13200	17600	22000	26400	
2500	4500	5625	6750	9000	11250	13500	18000	22500	27000	
	5500	6875	8250	11000	13750	16500	22000	27500	33000	
3000	5400	6750	8100	10800	13500	16200	21600	27000	32400	
	6600	8250	9900	13200	16500	19800	26400	33000	39600	
3200	5760	7200	8640	11520	14400	17280	23040	28800	34560	
	7040	8800	10560	14080	17600	21120	28160	35200	42240	
4000	7200	9000	10800	14400	18000	21600	28800	36000	43200	
	8800	11000	13200	17600	22000	26400	35200	44000	52800	

What you obtain from these tables is:

- Min and Max Long Delay Pickup Current (LDPU) from Table 14-1
- Min and Max Short Delay Pickup Current (SDPU) from Table 14-2
- Min and Max Instantaneous Pickup Current (INSTPU) from Table 14-2

You can now identify which timing band corresponds to the breaker current.

Breaker Current

Timing Band

- Less than Min LDPUNormal (No Trip)
- *Within Min and Max LDPU...Normal or Long Delay
- Between Max LPDULong Delay and Min SDPU
- *Within Min and Max SDPU ..Long Delay or Short Delay
- Between Max SPDU andShort Delay
- Min INSTPU
- *Within Min and MaxPrevious band or INSTPU Instantaneous
- Above Max INSTPUInstantaneous

*Currents within each pickup tolerance band (Min and Max LDPU, for example) may result in either that timing band or the previous timing band.

Table 14-3
Min and Max Trip Times for Long Delay Band

Long Delay Time (Sec.)	Current Level (Multiples of I _n)																			
	0.50	0.60	0.70	0.80	0.85	0.90	0.95	1.00	2.00	2.50	3.00	4.00	5.00	6.00	7.00	8.00	9.00	10.00	11.00	12.00
2	3:12	2:13	1:38	1:15	1:06	0:59	0:53	0:48	0:12	:07.6	:05.3	:03.0	:01.92	:01.33	:00.97	:00.75	:00.59	:00.48	:00.39	:00.33
2	4:48	3:20	2:27	1:52	1:40	1:29	1:20	1:12	0:18	:11.5	:08.0	:04.5	:02.85	:02.00	:01.46	:01.12	:00.88	:00.72	:00.59	:00.50
4	6:24	4:27	3:16	2:30	2:13	1:59	1:46	1:36	0:24	:15.3	:10.6	:06.0	:03.80	:02.65	:01.95	:01.50	:01.18	:00.96	:00.79	:00.66
4	9:36	6:40	4:54	3:45	3:19	2:58	2:40	2:24	0:36	:23.0	:16.0	:09.0	:05.70	:04.00	:02.90	:02.25	:01.77	:01.44	:01.19	:01.00
7	11:12	7:47	5:43	4:22	3:53	3:27	3:06	2:48	0:42	:27.0	:18.6	:10.5	:06.70	:04.65	:03.40	:02.60	:02.05	:01.68	:01.38	:01.16
7	16:48	11:40	8:34	6:34	5:49	5:11	4:39	4:12	1:03	:40.0	:28.0	:15.7	:10.00	:07.00	:05.10	:03.90	:03.10	:02.50	:02.05	:01.75
10	16:00	11:07	8:10	6:15	5:32	4:56	4:26	4:00	1:00	:38.5	:26.5	:15.0	:09.60	:06.60	:04.85	:03.75	:02.95	:02.40	:01.98	:01.66
10	24:00	16:40	12:15	9:22	8:18	7:24	6:39	6:00	1:30	:57.5	:40.0	:22.5	:14.40	:10.00	:07.30	:05.60	:04.40	:03.60	:02.95	:02.50
12	19:12	13:20	9:48	7:30	6:39	5:56	5:19	4:48	1:12	:46.0	:32.0	:18.0	:11.50	:08.00	:05.80	:04.50	:03.55	:02.85	:02.35	:02.00
12	28:48	20:00	14:42	11:15	9:58	8:53	7:59	7:12	1:48	1:09	:40.0	:27.0	:17.20	:12.00	:08.80	:06.70	:05.30	:04.30	:03.55	:03.00
15	24:00	16:40	12:15	9:22	8:18	7:24	6:39	6:00	1:30	:57.5	:40.0	:22.5	:14.40	:10.00	:07.30	:05.60	:04.40	:03.60	:02.95	:02.50
15	36:00	25:00	18:22	14:04	12:27	11:07	9:58	9:00	2:15	1:26	1:00	:33.5	:21.50	:15.00	:11.00	:08.40	:06.60	:05.40	:04.45	:03.75
20	32:00	22:13	16:20	12:30	11:04	9:53	8:52	8:00	2:00	1:17	:53.0	:30.0	:19.20	:13.30	:09.80	:07.50	:05.90	:04.80	:03.95	:03.30
20	48:00	33:20	24:29	18:45	16:37	14:49	13:18	12:00	3:00	1:55	1:20	:45.0	:28.50	:20.00	:14.60	:11.20	:08.80	:07.20	:05.90	:05.00
24	38:24	26:40	19:36	15:00	13:17	11:51	10:38	9:36	2:24	1:32	1:04	:36.0	:23.00	:16.00	:11.70	:09.00	:07.10	:05.70	:04.75	:04.00
24	57:36	40:00	29:23	22:30	19:56	17:47	15:57	14:24	3:36	2:18	1:36	:54.0	:34.50	:24.00	:17.60	:13.50	:10.60	:08.60	:07.10	:06.00

Time Values Are Shown in Minutes:Seconds.Fractional Seconds

Now that you can identify which timing band corresponds to the Breaker Current, you may proceed to identify the trip time corresponding to the Breaker Current and the timing band in effect by referring to Tables 14-3 and 14-4.

Information required to use these tables is:

- Long Delay Time switch setting Table 14-3
- Long Delay Pickup switch setting Table 14-3
- *Short Delay Time switch setting Table 14-4
- *Short Delay Pickup switch setting Table 14-4
- *Instantaneous Pickup switch setting Table 14-4

*(Your Trip Unit may or may not have this switch, depending on the protection functions supplied).

Table 14-4
Min and Max Trip Times for Short Delay and Instantaneous Band

Short Delay Time (Sec.)	Current Level (Multiples of I_n)												
	2.0	2.5	3.0	4.0	5.0	6.0	7.0	8.0	9.0	10.0	11.0	12.0	13.0+
0.1	0.07	0.04	0.04	0.04	0.04	0.04	0.04	0.04	0.04	0.04	0.04	0.04	0.04
0.1	0.20	0.17	0.17	0.17	0.17	0.17	0.17	0.17	0.17	0.17	0.17	0.17	0.17
0.2	0.23	0.19	0.14	0.14	0.14	0.14	0.14	0.14	0.14	0.14	0.14	0.14	0.14
0.2	0.35	0.29	0.23	0.23	0.23	0.23	0.23	0.23	0.23	0.23	0.23	0.23	0.23
0.3	0.33	0.28	0.20	0.20	0.20	0.20	0.20	0.20	0.20	0.20	0.20	0.20	0.20
0.3	0.50	0.41	0.33	0.33	0.33	0.33	0.33	0.33	0.33	0.33	0.33	0.33	0.33
0.4	0.38	0.32	0.25	0.25	0.25	0.25	0.25	0.25	0.25	0.25	0.25	0.25	0.25
0.4	0.57	0.48	0.38	0.38	0.38	0.38	0.38	0.38	0.38	0.38	0.38	0.38	0.38
0.5	0.57	0.38	0.38	0.38	0.38	0.38	0.38	0.38	0.38	0.38	0.38	0.38	0.38
0.5	0.75	0.50	0.50	0.50	0.50	0.50	0.50	0.50	0.50	0.50	0.50	0.50	0.50
0.1*	1.23	0.78	0.54	0.31	0.20	0.14	0.10	0.08	0.07	0.06	0.06	0.05	0.05
0.1*	2.45	1.57	1.09	0.61	0.39	0.27	0.20	0.19	0.18	0.17	0.17	0.17	0.17
0.3*	3.20	2.05	1.42	0.80	0.51	0.36	0.26	0.20	0.20	0.20	0.20	0.20	0.20
0.3*	4.90	3.14	2.18	1.23	0.78	0.54	0.40	0.36	0.33	0.33	0.33	0.33	0.33
0.5*	6.08	3.89	2.70	1.52	0.97	0.68	0.50	0.38	0.38	0.38	0.38	0.38	0.38
0.5*	9.92	6.35	4.41	2.48	1.59	1.10	0.81	0.62	0.55	0.51	0.50	0.50	0.50

* Denotes I²t response

Instantaneous Time (Sec.)	Current Level (Multiples of I_n)												
	2.0	2.5	3.0	4.0	5.0	6.0	7.0	8.0	9.0	10.0	11.0	12.0	13.0+
Minimum	0.010	0.010	0.010	0.010	0.010	0.010	0.010	0.010	0.010	0.010	0.010	0.010	0.010
Maximum	0.046	0.046	0.046	0.046	0.046	0.046	0.046	0.046	0.046	0.046	0.046	0.046	0.046

Time Values Are Shown in Seconds. Fractional Seconds

Notes:

- Trip times are shown exclusive of breaker clearing time
- Trip times may be slower than shown if current is near the pickup value
- Trip times may be faster for currents much greater than 12X
- Trip times for short delay shown with zone interlock restraining signal present

You can mark the Timing Bands in Tables 14-3 and 14-4 as follows:

Timing Band	Beginning	End	
Long Delay	LDPU setting	SDPU setting or INSTPU setting	Which ever is first.
Short Delay	SDPU setting	INSTPU setting or 13 and Above	Which ever is first.
Instantaneous	INSTPU setting	13 And Above	

14-3. An Example of Using Time-Current Tables (LSI)

The Breaker and Retrofit Kit for this example is a DB-25 with a Digitrip 800 LSI Trip System and a 600 amp Rating Plug. The information required for Tables 14-1 through 14-4 is:

Description	Value	Units	Example Symbol
Rating Plug Rating (I_n)	600	Amps	A
Long Delay Pickup (LDPU)	0.6	$\times I_n$	B
Long Delay Time (LDT)	10	Seconds	C
Short Delay Pickup (SDPU)	4	$\times I_n$	D
Short Delay Time (SDT)	0.5*	Seconds	E
Instantaneous Pickup (INST)	8	$\times I_n$	F

Using Example Table 14-1, for a Plug Rating (I_n) of 600 and LDPU of 0.6 (symbols A and B in the Example Table), we find that:

Min LDPU = 360 amps (Symbol G)
 Max LDPU = 396 amps (Symbol G)

Using Example Table 14-2, for a Plug Rating (I_n) of 600 and SDPU of 4 (symbols A and D in the Example Table), we find that:

Min SDPU = 2160 amps (Symbol H)
 Max SDPU = 2640 amps (Symbol H)

Using Example Table 14-2, for a Plug Rating (I_n) of 600 and INST of 8 (symbols A and F in the Example Table), we find that:

Min INST = 4320 amps (Symbol I)
 Max INST = 5280 amps (Symbol I)

On Example Table 14-3, we mark the Long Delay Band:

Beginning = 6 (I_n) (Symbol B)
 End = 4 (I_n) (Symbol D)
 On Long Delay Time = 10 (Symbol C)

On Example Table 14-4, we mark the Short Delay Band:

Beginning = 4 (I_n) (Symbol D)
 End = 8 (I_n) (Symbol F)
 On Short Delay Time = .5* (Symbol E)

On Example Table 14-4, we mark the Instantaneous Band:

Beginning = 8 (I_n) (Symbol F)
 End = 13 (I_n) & Up (Highest Value)

WWW.ElectricalPartManuals.com

Table 14-1 Example
Long Delay Pick-up Currents

Minimum = -0%; Maximum = +10% Tolerance

Plug Rating (I _n)	Minimum = -0%; Maximum = +10% Tolerance							
	0.50	0.60	0.70	0.80	0.85	0.90	0.95	1.00
100	50 55	60 66	70 77	80 88	85 94	90 99	95 105	100 110
200	100 110	120 132	140 154	160 176	170 187	180 198	190 209	200 220
250	125 138	150 165	175 193	200 220	213 234	225 248	238 261	250 275
300	150 165	180 198	210 231	240 264	255 281	270 297	285 314	300 330
400	200 220	240 264	280 308	320 352	340 374	360 396	380 418	400 440
600	300 330	360 396	420 462	480 528	510 561	540 594	570 627	600 660
800	400 440	480 528	560 616	640 704	680 748	720 792	760 836	800 880
1000	500 550	600 660	700 770	800 880	850 935	900 990	950 1045	1000 1100
1200	600 660	720 792	840 924	960 1056	1020 1122	1080 1188	1140 1254	1200 1320
1600	800 880	960 1056	1120 1232	1280 1408	1360 1496	1440 1584	1520 1672	1600 1760
2000	1000 1100	1200 1320	1400 1540	1600 1760	1700 1870	1800 1980	1900 2090	2000 2200
2500	1250 1375	1500 1650	1750 1925	2000 2200	2125 2338	2250 2475	2375 2613	2500 2750
3000	1500 1650	1800 1980	2100 2310	2400 2640	2550 2805	2700 2970	2850 3135	3000 3300
3200	1600 1760	1920 2112	2240 2464	2560 2816	2720 2992	2880 3168	3040 3344	3200 3520
4000	2000 2200	2400 2640	2800 3080	3200 3520	3400 3740	3600 3960	3800 4180	4000 4400

Table 14-2 Example
Short Delay and Instantaneous Pick-up Currents

Minimum = -10%; Maximum = +10% Tolerance

Plug Rating (I _n)	Minimum = -10%; Maximum = +10% Tolerance									
	2.0	2.5	3.0	4.0	5.0	6.0	8.0	10.0	12.0	
100	180 220	225 275	270 330	360 440	450 550	540 660	720 880	900 1100	1080 1320	
200	360 440	450 550	540 660	720 880	900 1100	1080 1320	1440 1760	1800 2200	2160 2640	
250	450 550	563 688	675 825	810 990	900 1100	1080 1320	1350 1650	1800 2200	2250 2750	
300	540 660	675 825	810 990	1080 1320	1350 1650	1620 1980	2160 2640	2700 3300	3240 3960	
400	720 880	900 1100	1080 1320	1440 1760	1800 2200	2160 2640	2880 3520	3600 4400	4320 5280	
600	1080 1320	1350 1650	1620 1980	2160 2640	2700 3300	3240 3960	4320 5280	5400 6600	6480 7920	
800	1440 1760	1800 2200	2160 2640	2880 3520	3600 4400	4320 5280	5760 7040	7200 8800	8640 10560	
1000	1800 2200	2250 2750	2700 3300	3600 4400	4500 5500	5400 6600	7200 8800	9000 11000	10800 13200	
1200	2160 2640	2700 3300	3240 3960	4320 5280	5400 6600	6480 7920	8640 10560	10800 13200	12960 15640	
1600	2880 3520	3600 4400	4320 5280	5760 7040	7200 8800	8640 10560	11520 14080	14400 17600	17280 21120	
2000	3600 4400	4500 5500	5400 6600	7200 8800	9000 11000	10800 13200	14400 17600	18000 22000	21600 26400	
2500	4500 5500	5625 6875	6750 8250	8100 9900	9000 11000	10800 13200	14400 17600	18000 22000	22500 27500	
3000	5400 6600	6750 8250	8100 9900	10800 13200	13500 16500	16200 19800	21600 26400	27000 33000	32400 39600	
3200	5760 7040	7200 8800	8640 10560	11520 14080	14400 17600	17280 21120	23040 28160	28800 35200	34560 42240	
4000	7200 8800	9000 11000	10800 13200	14400 17600	18000 22000	21600 26400	28800 35200	36000 44000	43200 52800	

Table 14-3 Example
Min and Max Trip Times for Long Delay Band

Long Delay Time (Sec.)	Current Level (Multiples of I _n)																			
	0.50	0.60	0.70	0.80	0.85	0.90	0.95	1.00	2.00	2.50	3.00	4.00	5.00	6.00	7.00	8.00	9.00	10.00	11.00	12.00
2	3:12	2:13	1:38	1:15	1:06	0:59	0:53	0:48	0:12	:07.6	:05.3	:03.0	:01.92	:01.33	:00.97	:00.75	:00.59	:00.48	:00.39	:00.33
2	4:48	3:20	2:27	1:52	1:40	1:29	1:20	1:12	0:18	:11.5	:08.0	:04.5	:02.85	:02.00	:01.46	:01.12	:00.88	:00.72	:00.59	:00.50
4	6:24	4:27	3:16	2:30	2:13	1:59	1:46	1:36	0:24	:15.3	:10.6	:06.0	:03.80	:02.65	:01.95	:01.50	:01.18	:00.96	:00.79	:00.66
4	9:36	6:40	4:54	3:45	3:19	2:58	2:40	2:24	0:36	:23.0	:16.0	:09.0	:05.70	:04.00	:02.90	:02.25	:01.77	:01.44	:01.19	:01.00
7	11:12	7:47	5:43	4:22	3:53	3:27	3:06	2:48	0:42	:27.0	:18.6	:10.5	:06.70	:04.65	:03.40	:02.60	:02.05	:01.68	:01.38	:01.16
7	16:48	11:40	8:34	6:34	5:49	5:11	4:39	4:12	1:03	:40.0	:28.0	:15.7	:10.00	:07.00	:05.10	:03.90	:03.10	:02.50	:02.05	:01.75
10	16:00	11:07	8:10	6:15	5:32	4:56	4:26	4:00	1:00	:38.5	:26.5	:15.0	:09.60	:06.60	:04.85	:03.75	:02.95	:02.40	:01.98	:01.66
10	24:00	16:40	12:15	9:22	8:18	7:24	6:39	6:00	1:30	:57.5	:40.0	:22.5	:14.40	:10.00	:07.30	:05.60	:04.40	:03.60	:02.95	:02.50
12	19:12	13:20	9:48	7:30	6:39	5:56	5:19	4:48	1:12	:46.0	:32.0	:18.0	:11.50	:08.00	:05.80	:04.50	:03.55	:02.85	:02.35	:02.00
12	28:48	20:00	14:42	11:15	9:58	8:53	7:59	7:12	1:48	1:09	:40.0	:27.0	:17.20	:12.00	:08.80	:06.70	:05.30	:04.30	:03.55	:03.00
15	24:00	16:40	12:15	9:22	8:18	7:24	6:39	6:00	1:30	:57.5	:40.0	:22.5	:14.40	:10.00	:07.30	:05.60	:04.40	:03.60	:02.95	:02.50
15	36:00	25:00	18:22	14:04	12:27	11:07	9:58	9:00	2:15	1:26	1:00	:33.5	:21.50	:15.00	:11.00	:08.40	:06.60	:05.40	:04.45	:03.75
20	32:00	22:13	16:20	12:30	11:04	9:53	8:52	8:00	2:00	1:17	:53.0	:30.0	:19.20	:13.30	:09.80	:07.50	:05.90	:04.80	:03.95	:03.30
20	48:00	33:20	24:29	18:45	16:37	14:49	13:18	12:00	3:00	1:55	1:20	:45.0	:28.50	:20.00	:14.60	:11.20	:08.80	:07.20	:05.90	:05.00
24	38:24	26:40	19:36	15:00	13:17	11:51	10:38	9:36	2:24	1:32	1:04	:36.0	:23.00	:16.00	:11.70	:09.00	:07.10	:05.70	:04.75	:04.00
24	57:36	40:00	29:23	22:30	19:56	17:47	15:57	14:24	3:36	2:18	1:36	:54.0	:34.50	:24.00	:17.60	:13.50	:10.60	:08.60	:07.10	:06.00

Time Values Are Shown in Minutes:Seconds.Fractional Seconds

www.ElectricalPanelMag.com

Table 14-4 Example
Min and Max Trip Times for Short Delay and Instantaneous Band

Short Delay Time (Sec.)	Current Level (Multiples of I_n)												
	2.0	2.5	3.0	4.0	5.0	6.0	7.0	8.0	9.0	10.0	11.0	12.0	13.0+
0.1	0.07	0.04	0.04	0.04	0.04	0.04	0.04	0.04	0.04	0.04	0.04	0.04	0.04
0.1	0.20	0.17	0.17	0.17	0.17	0.17	0.17	0.17	0.17	0.17	0.17	0.17	0.17
0.2	0.23	0.19	0.14	0.14	0.14	0.14	0.14	0.14	0.14	0.14	0.14	0.14	0.14
0.2	0.35	0.29	0.23	0.23	0.23	0.23	0.23	0.23	0.23	0.23	0.23	0.23	0.23
0.3	0.33	0.28	0.20	0.20	0.20	0.20	0.20	0.20	0.20	0.20	0.20	0.20	0.20
0.3	0.50	0.41	0.33	0.33	0.33	0.33	0.33	0.33	0.33	0.33	0.33	0.33	0.33
0.4	0.38	0.32	0.25	0.25	0.25	0.25	0.25	0.25	0.25	0.25	0.25	0.25	0.25
0.4	0.57	0.48	0.38	0.38	0.38	0.38	0.38	0.38	0.38	0.38	0.38	0.38	0.38
0.5	0.57	0.38	0.38	0.38	0.38	0.38	0.38	0.38	0.38	0.38	0.38	0.38	0.38
0.5	0.75	0.50	0.50	0.50	0.50	0.50	0.50	0.50	0.50	0.50	0.50	0.50	0.50
0.1*	1.23	0.78	0.54	0.31	0.20	0.14	0.10	0.08	0.07	0.06	0.06	0.05	0.05
0.1*	2.45	1.57	1.09	0.61	0.39	0.27	0.20	0.18	0.18	0.17	0.17	0.17	0.17
0.3*	3.20	2.05	1.42	0.80	0.51	0.36	0.26	0.20	0.20	0.20	0.20	0.20	0.20
0.3*	4.90	3.14	2.18	1.23	0.78	0.54	0.40	0.36	0.33	0.33	0.33	0.33	0.33
0.5*	6.08	3.89	2.70	1.52	0.97	0.68	0.50	0.38	0.38	0.38	0.38	0.38	0.38
0.5*	8.92	6.35	4.41	2.48	1.59	1.10	0.81	0.62	0.55	0.51	0.50	0.50	0.50

* Denotes I²t response

Instantaneous Time (Sec.)	Current Level (Multiples of I_n)												
	2.0	2.5	3.0	4.0	5.0	6.0	7.0	8.0	9.0	10.0	11.0	12.0	13.0+
Minimum	0.010	0.010	0.010	0.010	0.010	0.010	0.010	0.010	0.010	0.010	0.010	0.010	0.010
Maximum	0.046	0.046	0.046	0.046	0.046	0.046	0.046	0.046	0.046	0.046	0.046	0.046	0.046

Time Values Are Shown in Seconds, Fractional Seconds

Notes:

- Trip times are shown exclusive of breaker clearing time
- Trip times may be slower than shown if current is near the pickup value
- Trip times may be faster for currents much greater than 12X
- Trip times for short delay shown with zone interlock restraining signal present

14-4. Curve Plotting Aids (LSI)

The Time-Current Curves shown in Figures 3-2 and 3-3 accurately describe the response of the Digitrip RMS Retrofit Kit Trip System to all relevant levels of current and trip unit protection function switch settings, but they are sometimes difficult to interpret for specific combinations of Rating Plugs and Switch Settings. The purpose of this section is to provide an easy method for plotting the the trip system response on your own graphs rather than transfer information from the Figures.

The method we follow is based on the following observations:

- The Pickup values of current (Min and Max) are vertical lines on the Time-Current plot.
- The Trip times (Min and Max) for Instantaneous and Short Delay (Flat) are horizontal lines on the Time-Current plot. These lines do bend upward for currents close to the pickup value (see Figures 3-2, 3-3), so some "radiusing" will be appropriate in these regions.



GRAPH PAPER:

The log-log paper you use should have 6 decades of time on the vertical axis (from .01 seconds to 10,000 seconds) and 4 decades of current on the horizontal axis (from 10 amps to 100 KA). If your paper is limited to 5 decades of time, eliminate the decade above 1,000 seconds. This will only pose plotting difficulties for higher values of Long Delay Time in combination with lower values of Long Delay Pickup, but that area of the plot can exist above the 1,000 second region with little loss of information.

Step 1: Label the Time (vertical) scale and the Current (horizontal) scale.

Step 2: Draw in CONSTRUCTION lines (lightly) for the various sections of the curve.

CONSTRUCTION LINES:

Long Delay Pickup Current (LDPU): Use Table 14-1 with your Rating Plug Rating (I_n) and Long Delay Pickup Setting to find the Min and Max current values. Draw two vertical lines from 100 sec to 5000 sec at these current values.

Short Delay Pickup Current (SDPU) (skip this step if Short Delay not supplied): Use Table 14-2 with your Rating Plug Rating (I_n) and Short Delay Pickup Setting to find the Min and Max current values. Draw two vertical lines from 0.1 sec to 500 sec at these current values.

Instantaneous Pickup Current (INSTPU) (skip this step if Instantaneous not supplied): Use Table 14-2 with your Rating Plug Rating (I_n) and Instantaneous Pickup Setting to find the Min and Max current values. Draw two vertical lines from .01 sec to 500 sec at these current values.

Long Delay Time (LDT) (Max): This is a sloped line, drawn between an upper left point and lower right point:

Upper Left point:
 Current = 1 x Rating Plug Rating (I_n) (amps)
 Time = Value from Table 14-5

Lower Right point:
 Current = 10 x Rating Plug rating (I_n) (amps)
 Time = Value from table 14-5

If the sloped line does not intersect the Long Delay pickup (Max) line, extend the sloped line until it does.

Long Delay Time (LDT) (Min): This is a sloped line, drawn between an upper left point and a lower right point:

Upper Left point:
 Current = 1 x Rating Plug rating (I_n) (amps)
 Time = Value from Table 14-5

Lower Right point:
 Current = 10 x Rating Plug rating (I_n) (amps)
 Time = Value from Table 14-5

If the sloped line does not intersect the Long Delay pickup (Min) line, extend the sloped line until it does.

Short Delay Time (SDT) (Max) (Flat) (Skip this step if Short Delay not supplied): This is a horizontal line, drawn between 2 x I_n (amps) and 10 x I_n (amps) with the Time = Value from Table 14-6.

Short Delay Time (SDT) (Min) (Flat) (Skip this step if Short Delay not supplied): This is a horizontal line, drawn between 2 x I_n (amps) and 10 x I_n (amps) with the Time = Value from Table 14-6.

Table 14-5
 Long Delay Time Values

Description	Long Delay Time Settings (Seconds)							
	2	4	7	10	12	16	20	24
Maximum Upper Left Point	72.00	144.00	252.00	360.00	432.00	576.00	720.00	864.00
Maximum Lower Right Point	0.72	1.44	2.52	3.60	4.32	5.76	7.2	8.64
Minimum Upper Left Point	48.00	96.00	168.00	240.00	288.00	384.00	480.00	576.00
Minimum Lower Right Point	0.48	0.96	1.68	2.40	2.88	3.84	4.80	5.76

Table 14-6
Short Delay Time Values (Flat)

Description	(Seconds)				
	0.1	0.2	0.3	0.4	0.5
Maximum Horizontal Line	0.17	0.23	0.33	0.38	0.50
Minimum Horizontal Line	0.04	0.14	0.20	0.25	0.38

Short Delay Time (SDT) (Max) (I²t) (Skip this step if Short Delay not supplied): This is a sloped line changing to a horizontal line near 8 x I_n. This sloped portion is drawn between an upper left and lower right point:

Upper Left point:
Current = 2 x Rating Plug rating (I_n) (amps)
Time = Value from Table 14-7

Lower Right point:
Current = 10 x Rating Plug rating (I_n) (amps)
Time = Value from Table 14-7

The horizontal portion is drawn between 7 x I_n (amps) and 10 x I_n (amps) with the Time = Value from Table 14-7.

Short Delay Time (SDT) (Min) (I²t) (Skip this step if Short Delay not supplied): This is a sloped line changing to a horizontal line near 8 x I_n. The sloped portion is drawn between an upper left and lower right point:

Upper Left point:
Current = 2 x Rating Plug rating (I_n) (Amps)
Time = Value from Table 14-7

Lower Right point:
Current = 10 x Rating Plug rating (I_n) (amps)
Time = Value from Table 14-7

The horizontal portion is drawn between 7 x I_n (amps) and 10 x I_n (amps) with the Time = Value from Table 14-7.

Instantaneous Time (INSTT) (Max) (Skip this step if Instantaneous not supplied): This is a horizontal line drawn between 2 x I_n (amps) and 10 x I_n (amps) with the Time = .046 sec.

Table 14-7
Short Delay Time Values (I²t)

Description	(Seconds)		
	.1*	.3*	.5*
Maximum Upper Left Point	2.450	4.900	9.900
Maximum Lower Right Point	0.098	0.196	0.396
Maximum Horizontal Line	0.170	0.330	0.500
Minimum Upper Left Point	1.240	3.200	6.100
Minimum Lower Right Point	0.049	0.128	0.244
Minimum Horizontal Line	0.040	0.200	0.380

Instantaneous Time (INSTT) (Min) (Skip this step if Instantaneous not supplied): This is a horizontal line drawn between 2 x I_n (amps) and 10 x I_n (amps) with the Time = .01 sec.

Step 3: Darken the FINAL lines by tracing over segments of the construction lines.

First darken the Min response curve:

Start at the top of the Long Delay Pickup (Min) line and trace down to the intersection with the Long Delay Time (Min) line.

Continue the trace along the Long Delay Time (Min) line to the intersection with the next vertical pickup line.

- For a LI Trip Unit, it is the Instantaneous Pickup (Min).
- For a LS Trip Unit, it is the Short Delay Pickup (Min).
- For a LSI Trip Unit, it is the Short Delay Pickup (Min).

Continue the trace down the pickup line to the intersection with the next time line.

- For a LI Trip Unit, it is the Instantaneous Time (Min).†
- For a LS Trip Unit, it is the Short Delay Time (Min).†
- For a LSI Trip Unit, it is the Short Delay Time (Min).†

†Remember to radius these intersections.

Continue the trace along the time line to the intersection with the next vertical pickup line.

For a LI Trip Unit, there is no next pickup, so continue the instantaneous time line to the maximum available fault current (determined by your power system study).

For a LS Trip Unit with a Flat time selection[†], there is no next pickup, so continue the short delay time line to the maximum available fault current (determined by your power system study).

For a LS Trip Unit with a I²t time selection, there is no next pickup, so continue down the slope to the intersection with the flat portion of the short delay time line[†], then continue to the maximum available fault current (determined by your power system study).

For a LSI Trip Unit with a Flat time selection[†], the next vertical pickup line is the Instantaneous Pickup (Min).

For a LSI Trip Unit with a I²t time selection, continue down the slope to the intersection with the flat portion of the short delay time line[†], then continue the intersection with the Instantaneous Pickup (Min).

(LSI trip units only) Continue the trace down the Instantaneous Pickup line to the intersection with the Instantaneous Time line[†], then continue along the time line to the maximum available fault current (determined by your power system study).

Now darken the Max response curve:

Start at the top of the Long Delay Pickup (Max) line and trace down to the intersection with the Long Delay Time (Max) line.

Continue the trace along the Long Delay Time (Max) line to the intersection with the next vertical pickup line.

- For a LI trip unit, it is the Instantaneous Pickup (Max).[†]
- For a LS trip unit, it is the Short Delay Pickup (Max).[†]
- For a LSI trip unit, it is the Short Delay Pickup (Max).[†]

[†] Remember to radius these intersections.

Continue the trace down the pickup line to the intersection with the next time line.

- For a LI trip unit, it is the Instantaneous Time (Max).[†]
- For a LS trip unit, it is the Short Delay Time (Max).[†]
- For a LSI trip unit, it is the Short Delay Time (Max).[†]

Continue the trace along the time line to the intersection with the next vertical pickup line.

For a LI Trip Unit, there is no next pickup, so continue the instantaneous time line to the maximum available fault current (determined by your power system study).

For a LS Trip Unit with a Flat time selection[†], there is no next pickup, so continue the short delay time line to the maximum available fault current (determined by your power system study).

For a LS Trip Unit with a I²t time selection, there is no next pickup, so continue down the slope to the intersection with the flat portion of the short delay time line[†], then continue to the maximum available fault current (determined by your power system study).

For a LSI Trip Unit with a Flat time selection[†], the next vertical pickup line is the Instantaneous Pickup (Max).

For a LSI Trip Unit with a I²t time selection, continue down the slope to the intersection with the flat portion of the short delay time line[†], then continue to the intersection with the Instantaneous Pickup (Max).

(LSI trip units only) Continue the trace down the Instantaneous Pickup line to the intersection with the Instantaneous Time line[†], then continue along the time line to the maximum available fault current (determined by your power system study).

[†] Remember to radius these intersections.

Step 4: Erase excess lengths of construction lines to clean up the curves.

We wish to thank you for purchasing the Digitrip Retrofit System. Digitrip Retrofit Kits are designed and manufactured in America with pride. All the components are engineered to fit the existing Circuit Breaker with little or no modifications to the existing Breaker. However due to the wide variety and vintage of Breakers in use today, an occasional problem may arise. Please contact us with any questions, comments or concerns.

Phone: **1-800-937-5487**
(412) 937-6727

Fax. (412) 937-6441

Cutler-Hammer

Five Parkway Center
Pittsburgh, PA 15220

Effective June, 1997
Printed in U.S.A. - K

EAT•N