





# Instructions for Digitrip Models 220, 520, 520i, 520M, and 520Mi Trip Units for use only in Cutler-Hammer Magnum and Magnum DS Circuit Breakers

## Table of Contents

1.0	General Description of Digitrip Trip Units .....	2	5.2	When to Test .....	22
1.1	Protection .....	4	5.3	Functional Field Testing .....	22
1.2	Mode of Trip and Status Information .....	4	5.4	Performance Testing for Ground Fault Trip Units .....	22
1.3	Installation and Removal .....	4	5.4.1	Code Requirements .....	22
1.3.1	Installation of the Trip Unit .....	4	5.4.2	Standards Requirements .....	22
1.3.2	Rating Plug Installation .....	4	5.4.3	General Test Instructions .....	22
1.3.3	Trip Unit/Rating Plug Removal .....	5	6.0	Battery .....	23
1.4	Wiring .....	6	6.1	General .....	23
1.5	Plexiglass Cover .....	6	6.2	Battery Check .....	23
1.6	Ground Alarm/Power Supply Module (520M Models only) .....	6	6.3	Battery Installation and Removal .....	24
1.6.1	Auxiliary Power .....	6	7.0	Frame Ratings (Sensor Ratings and Rating Plugs) .....	10, 24
1.6.2	Ground Alarm .....	6	8.0	Record Keeping .....	25
1.7	Display Feature (520M family only) .....	7	9.0	References .....	25
1.8	Standards .....	7	9.1	Magnum and Magnum DS Circuit Breakers .....	25
2.0	General Description of Magnum Circuit Breakers .....	7	9.2	Time-Current Curves .....	25
2.1	General .....	7	Appendix A	Zone Interlocking Examples .....	29
2.2	Low Energy Trip Actuator .....	8	Appendix B	Troubleshooting Guide .....	31
2.3	Ground Fault Protection .....	8	Appendix C	Typical Breaker Master Connection Diagram .....	33
2.3.1	General .....	9	<hr/>		
2.3.2	Residual Sensing .....	9	 <b>WARNING</b>		
2.3.3	Source Ground Sensing .....	9	<hr/>		
2.3.4	Zero Sequence Sensing .....	9	<b>DO NOT ATTEMPT TO INSTALL OR PERFORM MAINTENANCE ON EQUIPMENT WHILE IT IS ENERGIZED. DEATH OR SEVERE PERSONAL INJURY CAN RESULT FROM CONTACT WITH ENERGIZED EQUIPMENT. ALWAYS VERIFY THAT NO VOLTAGE IS PRESENT BEFORE PROCEEDING. ALWAYS FOLLOW SAFETY PROCEDURES. CUTLER-HAMMER IS NOT LIABLE FOR THE MISAPPLICATION OR MISINSTALLATION OF ITS PRODUCTS.</b>		
2.3.5	Multiple Source/Multiple Ground .....	9	<hr/>		
2.3.6	Ground Fault Settings .....	9	 <b>WARNING</b>		
2.4	Current Sensors (Magnum Frames less than or equal to 3200A) .....	10	<hr/>		
2.5	Current Sensors (Magnum Frames greater than 3200A) .....	10	<b>OBSERVE ALL RECOMMENDATIONS, NOTES, CAUTIONS, AND WARNINGS RELATING TO THE SAFETY OF PERSONNEL AND EQUIPMENT. OB- SERVE AND COMPLY WITH ALL GENERAL AND LOCAL HEALTH AND SAFETY LAWS, CODES, AND PROCEDURES.</b>		
3.0	Principles of Operation .....	10	<hr/>		
3.1	General .....	10	<hr/>		
3.2	Trip and Operation Indicators .....	15	<hr/>		
3.3	Making Current Release .....	15	<hr/>		
3.4	Zone Interlocking (520 family only) .....	15	<hr/>		
4.0	Protection Settings .....	19	<hr/>		
4.1	General .....	19	<hr/>		
4.2	Long Delay Current Setting .....	19	<hr/>		
4.3	Long Delay Time Setting .....	19	<hr/>		
4.4	Short Delay Current Setting .....	20	<hr/>		
4.5	Short Delay Time Setting .....	20	<hr/>		
4.6	Instantaneous Current Setting .....	20	<hr/>		
4.7	Ground Fault Current Setting .....	21	<hr/>		
4.8	Ground Fault Time Delay Setting .....	21	<hr/>		
5.0	Test Procedures .....	21	<hr/>		
5.1	General .....	21	<hr/>		

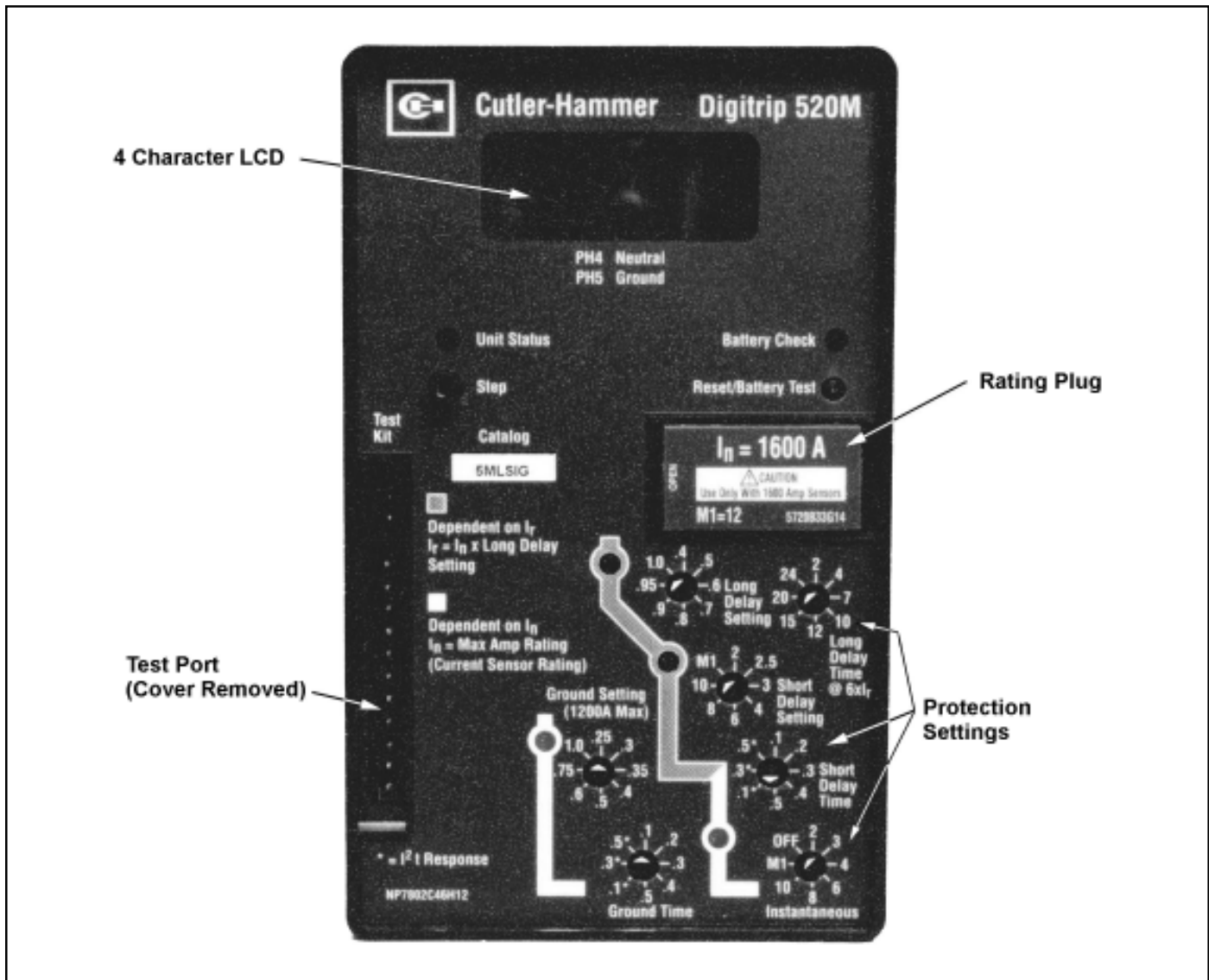

Figure 1.1 Digitrip 520M Trip Unit with Rating Plug

**NOTE:** The recommendations and information contained herein are based on experience and judgement, but should not be considered to be all inclusive or to cover every application or circumstance which may arise.

If you have any questions or need further information or instructions, please contact your local representative or the Customer Support Center at 1-800-356-1234.

**1.0 GENERAL DESCRIPTION OF DIGITRIP TRIP UNITS**

The Digitrip Trip Units are breaker subsystems that provide the protective functions of a circuit breaker. The trip units are in removable housings, installed in the breaker, and can be replaced or upgraded in the field by the customer.

This instruction book specifically covers the application of Digitrip Trip Units, as illustrated in Figure 1.1, installed in Magnum and Magnum DS Breakers. Throughout this Instructional Leaflet, the use of the term “Magnum Breakers” refers to both the Magnum and Magnum DS low-voltage, ac power circuit breakers.

The Magnum Digitrip line of trip units consists of the 220, 520, and 520M for UL standards and models 220, 520i, and 520Mi for IEC standards. Throughout this Instructional Leaflet, the use of the term “DT20 family” refers to the 220, 520, 520i, 520M, and 520Mi units; the term “520 family” refers to only the 520, 520i, 520M, and 520Mi units.

Table 1.1 Protection Types Available for Digitrip Trip Units

Trip Unit Type		Digitrip 220	Digitrip 520/520i	Digitrip 520M/520Mi
Ampere Range		200A-3200A	200A-6300A	200A-6300A
RMS Sensing		Yes	Yes	Yes
<b>Protection and Coordination</b>				
<b>Protection</b> Ordering Options		LI	LSI,LSIG/WLSIG	MLSI,MLSIG,MLSIA/MWLSIG
Fixed Rating Plug (h)		Yes	Yes	Yes
Overtemperature Trip		Yes	Yes	Yes
<b>Long</b>	Long Delay Setting	Fixed @ 1 x (h)	0.4-1.0 x (h)	0.4-1.0 x (h)
<b>Delay</b>	Long Delay Time I <sup>2</sup> t at 6 x (h)	Fixed @ 10 seconds	2-24 Seconds	2-24 Seconds
<b>Protection</b>	Long Delay Thermal Memory	Yes	Yes	Yes
<b>Short</b>	Short Delay Pick-Up <sup>4</sup>	No	200-1000% x (h)	200-1000% x (h)
<b>Delay</b>	Short Delay Time I <sup>2</sup> t at 8 x (h)	No	100-500 ms	100-500 ms
<b>Protection</b>	Short Delay Time FLAT	No	100-500 ms	100-500 ms
	Short Delay Time ZSI <sup>5</sup>	No	Yes	Yes
<b>Instantaneous</b>	Instantaneous Pick-Up <sup>4</sup>	200-1000% x (h)	200-1000% x (h)	200-1000% x (h)
	Off Position	No	Yes	Yes
<b>Protection</b>	Making Current Release	Yes	Yes	Yes
<b>Ground (Earth) Fault</b>	Ground Fault Option	No	Yes	Yes
	Ground Fault Alarm	No	No	Yes <sup>3</sup>
	Ground Fault Pick-Up	No	25-100% x (h) <sup>1</sup>	25-100% x (h) <sup>1</sup>
<b>Protection</b>	Ground Fault Delay I <sup>2</sup> t at .625 x (h)	No	100-500 ms	100-500 ms
	Ground Fault Delay Flat	No	100-500 ms	100-500 ms
	Ground Fault ZSI <sup>5</sup>	No	Yes	Yes
	Ground Fault Memory	No	Yes	Yes
<b>System Diagnostics</b>				
Status/Long Pick-up LED		Yes	Yes	Yes
Cause of Trip LEDs		No	Yes <sup>2</sup>	Yes <sup>2</sup>
Remote Ground Trip/Alarm Contacts		No	No	Yes <sup>3</sup>
<b>System Metering</b>				
Digital Display		No	No	4 Char. LCD

- Notes:
- Limited to 1200 Amperes; this is only for UL versions, not for IEC models.
  - Four cause of trip LEDs—L, S, I, G. Making Current Release is indicated by the Instantaneous LED.
  - Requires optional Ground Alarm/Power Supply Module (see Section 1.6).
  - Additional setting is marked M1 where:  
 800-3200A Frame: M1 = 14 x /n for Plug Amps 200 through 1250A  
 M1 = 12 x /n for Plug Amps 1600, 2000, 2500A  
 M1 = 10 x /n for Plug Amps 3000, 3200A  
 4000-6300A Frame: M1 = 14 x /n for Plug Amps 2000, 2500A (see Section 2.5)  
 M1 = 12 x /n for Plug Amps 3200, 4000, 5000A  
 M1 = 10 x /n for Plug Amps 6300A
  - ZSI = Zone Selective Interlock (see Section 3.4)

The Digitrip 220, 520, and 520M trip units may be applied on both 50 and 60 Hz systems.

Digitrip DT20 family of trip units are microprocessor-based ac protection devices that provide true RMS current sensing for the proper coordination with the thermal characteristics of conductors and equipment. The primary function of the Digitrip Trip Unit is circuit protection. The Digitrip analyzes the secondary current signals from the circuit breaker current sensors and, when preset current levels and time delay settings are exceeded, will send an initiating trip signal to the Trip Actuator of the circuit breaker.

In addition to the basic protection function, the Digitrip 520 family of trip units provides mode of trip information such as:

- Long Time trip (overload)
- Short Time trip
- Instantaneous trip
- Ground (Earth) Fault trip (if supplied).

The current sensors provide operating power to the trip unit. As current begins to flow through the breaker, the sensors generate a secondary current which powers the trip unit.

The Digitrip 520 family of trip units provides five phase and two ground (time-current) curve shaping adjustments. To satisfy the protection needs of any specific installation, the exact selection of the available protection function adjustments is optional. The short delay and ground fault pick-up adjustments can be set for either FLAT or  $I^2t$  response. A pictorial representation of the applicable time-current curves for the selected protection functions is provided, for user reference, on the face of the trip unit as shown in Figure 1.1.

### 1.1 Protection

Each Digitrip DT20 Trip Unit is completely self-contained and requires no external control power to operate its protection systems. It operates from current signal levels derived through current sensors mounted in the circuit breaker. The types of protection available for each model are shown in Table 1.1 and Figures 3.2 through 3.9.

**NOTE:** The Digitrip 220 (LI model), 520 (LSI model), and 520M (MLSI model) can be used on 3-pole or 4-pole circuit breakers for the protection of the neutral circuit. Only these three models can provide neutral protection, although models MLSIA, MLSIG, and MWLSIG can provide neutral metering (see Figures 3.7, 3.8, and 3.9). Refer to the National Electric Code (NEC) for the appropriate application for 4-pole breakers.

### 1.2 Mode of Trip and Status Information

On all DT20 units, a green light emitting diode (LED), labeled Status, blinks approximately once each second to indicate that the trip unit is operating normally. This Status LED will also blink at a faster rate if the Digitrip is in a pick-up, or overload, mode.

Red LEDs on the face of the 520 family of trip units (for Long Delay, Short Delay, and Instantaneous) flash to indicate the cause, or trip mode, for an automatic trip operation (for example, ground fault, overload, or short circuit trip). A battery in the Digitrip unit maintains the trip indication until the Reset/Battery Test button is pushed. The battery is satisfactory if its LED lights green when the Battery Check button is pushed (see Section 6).

**NOTE:** The Digitrip 520 family provides all protection functions regardless of the status of the battery. The battery is only needed to maintain the automatic trip indication.

### 1.3 Installation and Removal

#### 1.3.1 Installation of the Trip Unit

Align the Digitrip unit with the guide pins and spring clip of the Magnum Circuit Breaker. Press the unit into the breaker until the pins on the trip unit seat firmly into the connector housing and the unit clicks into place (see Figure 1.2).

#### 1.3.2 Rating Plug Installation



**DO NOT ENERGIZE THE MAGNUM BREAKER WITH THE DIGITRIP REMOVED OR DISCONNECTED FROM ITS CONNECTOR. DAMAGE TO INTERNAL CURRENT TRANSFORMERS MAY OCCUR DUE TO AN OPEN CIRCUIT CONDITION.**

---



**IF A RATING PLUG IS NOT INSTALLED IN THE TRIP UNIT, THE UNIT WILL TRIP WHEN IT IS ENERGIZED.**

Insert the rating plug into the cavity on the right-hand side of the trip unit. Align the three pins on the plug with the sockets in the cavity. The plug should fit with a slight insertion force.

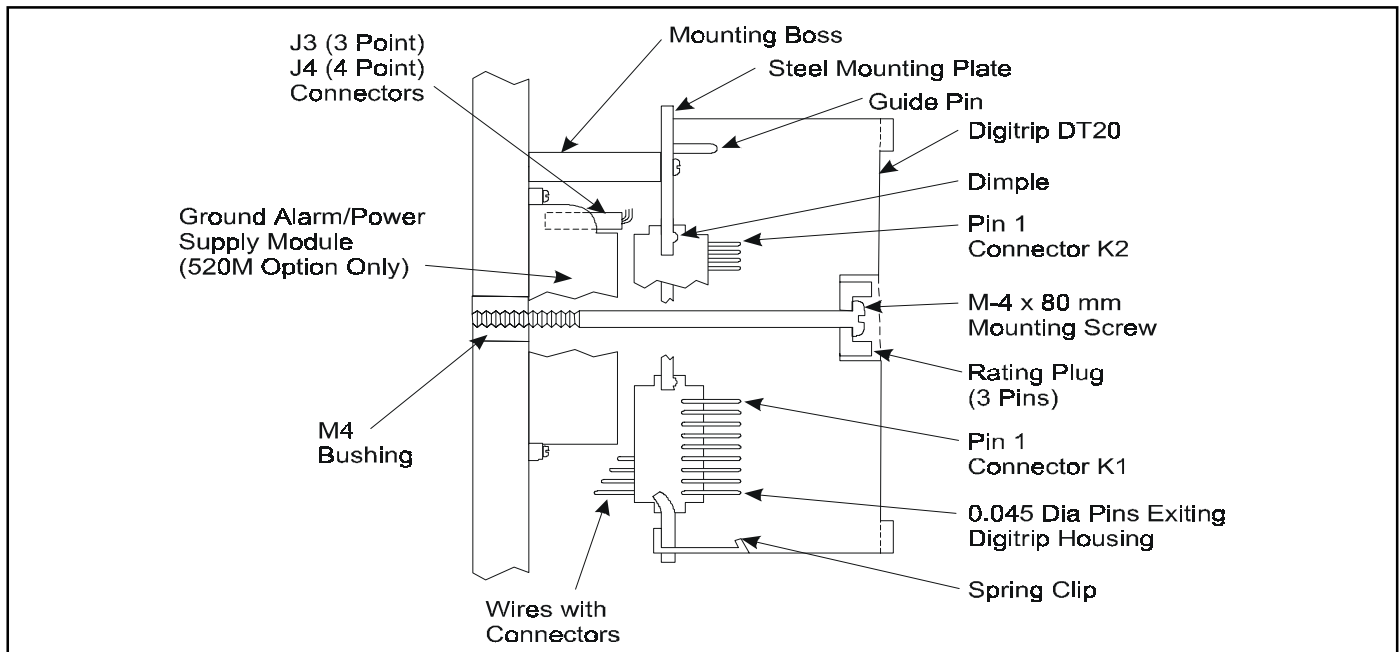

Figure 1.2 Installation of the Digitrip Unit into a Magnum Breaker (Side View)

**CAUTION**

**DO NOT FORCE THE RATING PLUG INTO THE CAVITY.**

Use a 1/8" (3 mm) wide screwdriver to tighten the M4 screw and secure the plug and the trip unit to the circuit breaker (see Figure 1.3). Close the rating plug door.

**CAUTION**

**THE M4 SCREW SHOULD BE TIGHTENED ONLY UNTIL IT IS SNUG. DO NOT USE A LARGE SCREWDRIVER. A 1/8" (3 mm) WIDE SCREWDRIVER BLADE IS ADEQUATE.**

**1.3.3 Trip Unit/Rating Plug Removal**

To remove the rating plug from the trip unit, open the rating plug door. Use a 1/8" (3 mm) wide screwdriver to loosen the M4 screw. Pull the door to release the rating plug from the trip unit.

To remove the trip unit from the circuit breaker, deflect the spring clip to release the unit from the steel mounting plate. Pull the unit to disengage the two 9-pin connectors from the circuit breaker (see Figure 1.2).



Figure 1.3 Installation of the Rating Plug and Mounting Screw

## 1.4 Wiring

The internal components of the breaker, and how they are wired out to the breaker secondary contacts, are shown in the breaker master connection diagram provided as Appendix C.

## 1.5 Plexiglass Cover

A clear, tamper-proof, plexiglass door sits on the breaker cover. This door allows the settings to be viewed but not changed, except by authorized personnel. The plexiglass cover meets applicable tamper-proof requirements. The cover is held in place by two cover screws. Security is insured by the insertion of a standard meter seal through the holes in both of the cover retention screws. The plexiglass cover has an access hole for the Step button on the 520M and 520Mi units.

## 1.6 Ground Alarm/Power Supply Module (520M Models only)

The Ground Alarm/Power Supply Module (see Figure 1.4) is an optional accessory for the Digitrip 520M and 520Mi models. The module can be installed beneath the metal mounting plate of the trip unit in the Magnum Circuit Breaker. The module covers the following input voltage ratings: 120 VAC (7802C83G01), 230 VAC (7802C83G02), and 24/48 VDC (7802C82G01).

### 1.6.1 Auxiliary Power

When the module is wired as shown in Figure 1.5, it will provide an auxiliary power supply so that the 520M/520Mi liquid crystal display (LCD) will be functional even when the circuit breaker has no load. A Digitrip 520M unit **without** auxiliary power will not display data until load current reaches approximately 25% 1 phase or 10% 3 phase of the (In) rating.

### 1.6.2 Ground Alarm

A second function of the module is to provide either a ground trip or ground alarm only output contact via the relay supplied in the module. On Digitrip 520M models with ground fault protection, an LED on the front of the unit also provides an indication of ground fault trip.

#### 1.6.2.1 Ground Fault Trip

When the Ground Alarm/Power Supply module is used with the MLSIG model, this unit will provide ground fault trip contacts when the circuit breaker trips on a ground fault. You must then push the Reset button on the Digitrip in order to reset the contacts (see Figure 1.5, Note 3).

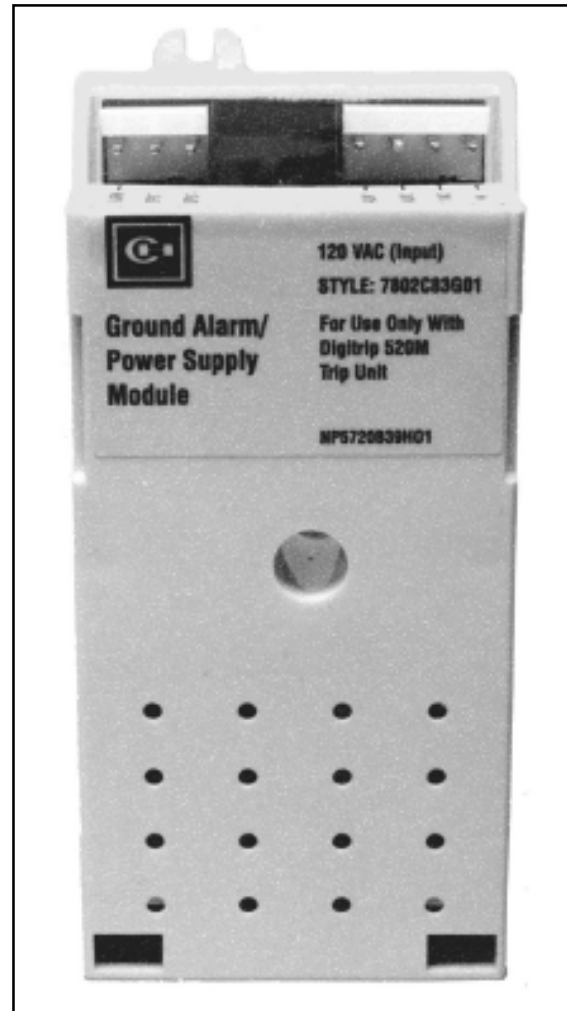

Figure 1.4 Optional Ground Alarm/Power Supply Module for 520M Trip Unit

#### 1.6.2.2 Ground Fault Alarm

A ground fault alarm alerts a user to a ground fault condition without tripping the circuit breaker. A red Alarm Only LED on the front of the trip unit will indicate the presence of a ground fault condition that exceeds the programmed setting.

The ground fault alarm relay is energized when the ground current continuously exceeds the ground fault pickup setting for a time in excess of a 0.1 second delay. The alarm relay will reset automatically if the ground current is less than the ground fault pickup (see Figure 1.5, Note 4).

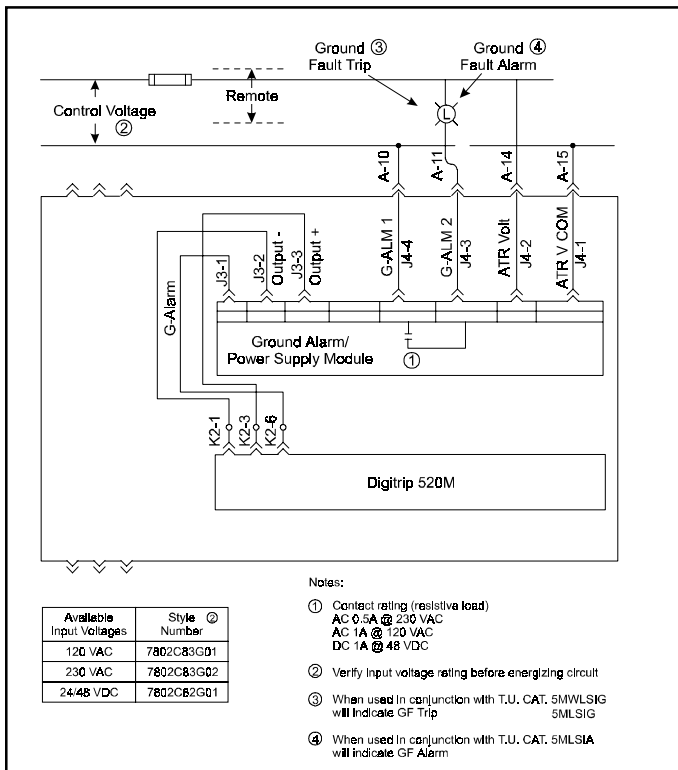

Figure 1.5 Wiring Diagram for 520M Models and Ground Alarm/Power Supply Module

### 1.7 Display Feature (520M family only)

The Digitrip 520M and 520Mi models have a user interface in addition to the green and red LED trip indicators. This seven element display performs a metering function and can be used to monitor load currents.

When the Step button on the face of the trip unit is pressed and released, the display will show PH 1, for Phase 1 or A, and the current value. If the Step button is not pressed again, the display will continue to show the current value for Phase 1. Each time that the Step button is pressed, the next monitored function will be displayed. The other readings can be displayed in the sequence below:

- PH 2 Phase 2 (B)
- PH 3 Phase 3 (C)
- PH 4 Neutral
- PH 5 Ground (if Ground function is supplied)
- HI Highest phase current

OL Overload (Digitrip in overload mode)

Pushing the Step button while the unit is in the OL mode will have the unit again display the overload current value.

HELP This message can indicate more than one problem with the trip unit. If the rating plug is missing, a HELP message and an Instantaneous trip LED light will be observed. The rating plug needs to be installed and the Instantaneous trip LED must be cleared by pressing the Reset/Battery Test button.

This message could also indicate that the trip unit is out of calibration and should be replaced at the earliest opportunity.

### 1.8 Standards

The Digitrip 220, 520, and 520M Trip Units are listed by the Underwriters Laboratories, Inc.,<sup>®</sup> under UL File E52096, for use in Magnum Circuit Breakers. These same units are also listed by the Canadian Standards Association (CSA) under file LR 43556.

All Digitrip units have also passed the IEC 947-2 test program which includes radiated and conducted emission testing. As a result, all units carry the CE mark.

## 2.0 GENERAL DESCRIPTION OF MAGNUM CIRCUIT BREAKERS

### 2.1 General

Magnum Circuit Breakers are tripped automatically on overload fault current conditions by the combined action of three components:

1. The Sensors, which measure the current level
2. The Digitrip Trip Unit, which provides a tripping signal to the Trip Actuator when current and time delay settings are exceeded
3. The low-energy Trip Actuator, which actually trips the circuit breaker

Figure 2.1 shows this tripping circuit for a typical Magnum Breaker. This arrangement provides a very flexible system, covering a wide range of tripping characteristics described by the time-current curves referenced in Section 9.2.

The automatic overload and short circuit tripping characteristics for a specific circuit breaker are determined by the ratings of the installed current sensors with a matching rating plug and the selected functional protection settings. Specific setting instructions are provided in Section 4.

When the functional protection settings are exceeded, the Digitrip unit supplies a trip signal to the Trip Actuator. As a result, all tripping operations initiated by the protection functions of the Digitrip Trip Unit are performed by its internal circuitry. There is no mechanical or direct magnetic action between the primary current and the mechanical tripping parts of the breaker, and external control power is not required.

located under the black molded platform on which the Digitrip unit is supported. The Trip Actuator contains a permanent magnet assembly, moving and stationary core assemblies, a spring, and a coil. Nominal coil resistance is 25 ohms and the black lead is positive. The circuit breaker mechanism assembly contains a mechanism-actuated reset lever and a trip lever to actuate the tripping action of the circuit breaker.

**! WARNING**

**IMPROPER POLARITY CONNECTIONS ON THE TRIP ACTUATOR COIL WILL DEFEAT THE OVERLOAD AND SHORT CIRCUIT PROTECTION, WHICH COULD RESULT IN PERSONAL INJURY.**

**OBSERVE POLARITY MARKINGS ON THE TRIP ACTUATOR LEADS AND CONNECT THEM PROPERLY, USING THE INSTRUCTIONS PROVIDED.**

**2.2 Low-Energy Trip Actuator**

The mechanical force required to initiate the tripping action of a Magnum Circuit Breaker is provided by a special low-energy Trip Actuator. The Trip Actuator is

When the Trip Actuator is reset by the operating mechanism, the moving core assembly is held in readiness against the force of the compressed spring by the permanent magnet. When a tripping action is initiated, the low-energy Trip Actuator coil receives a tripping pulse from the Digitrip unit. This pulse overcomes the holding effect of the permanent magnet, and the moving core is released to trigger the tripping operation via the trip lever.

**2.3 Ground Fault Protection**

**NOTE:** The Digitrip Model 220 is not available with ground fault protection. Only the 520 family has ground fault types available.

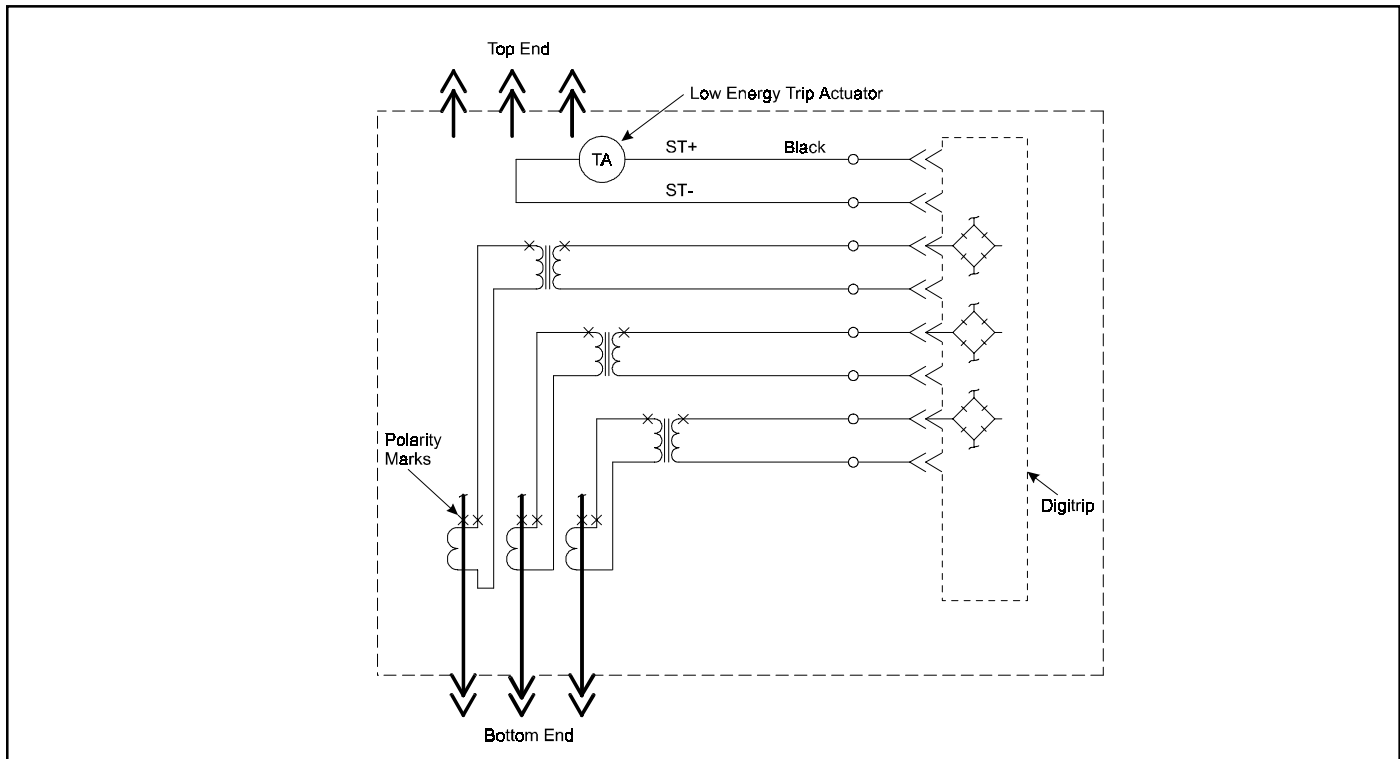

Figure 2.1 Tripping Circuit for a Typical Magnum Breaker (Partial)

### 2.3.1 General

When the Digitrip 520 family includes ground fault protection features, the distribution system characteristics (for example, system grounding, number of sources, number and location of ground points, and the like) must be considered along with the manner and location in which the circuit breaker is applied to the system. These elements are discussed in Sections 2.3.3 through 2.3.6.

The Digitrip 520 family uses three modes of sensing to detect ground fault currents: residual, source ground, and zero sequence (see Table 2.1). Magnum Circuit Breakers can accommodate all three types, except for 4-pole breakers. The breaker secondary contact inputs B-6, B-7 are used to configure the breaker cell positions for the three schemes. No jumper from B-6 to B-7 programs the unit for a residual ground fault scheme, while a jumper from B-6 to B-7 programs the trip unit for either a source ground or zero sequence configuration. If present, this jumper resides on the stationary side of the switchgear assembly. In all three schemes, the proper current sensor input is required on the external sensor input terminals B-4, B-5 of the breaker secondary contacts.

Table 2.1 Digitrip Sensing Modes

Ground (Earth) Fault Sensing Method	Breaker Secondary Contacts Req'd	Applicable Breakers	Figure Reference	Digitrip GF Sensing Element Used
Residual	No Jumper	3 or 4 pole	2.2, 2.3, 2.5, 2.9	element R5
Source Ground	Jumper B6 to B7	3 pole only	2.7	element R4
Zero Sequence	Jumper B6 to B7	3 pole only	2.8	element R4

Note: This information applies to Trip Units with Ground

### 2.3.2 Residual Sensing

Residual Sensing is the standard mode of ground fault sensing in Magnum Circuit Breakers. This mode utilizes one current sensor on each phase conductor and one on the neutral for a 4-wire system (shown in Figures 2.2 and 2.3). If the system neutral is grounded, but no phase to neutral loads are used, the Digitrip 520 family of units includes all of the components necessary for ground fault protection. This mode of sensing vectorially sums the outputs of the three or four individual current sensors. For separately-mounted neutrals, as long as the vectorial sum is zero, then no ground fault exists. The neutral sensor must have characteristics and a ratio which are identical to the three internally-mounted phase current sensors. Available types of neutral sensors are shown in Figure 2.4. Residual ground fault sensing features are adaptable to main and feeder breaker applications. Available ground fault pick-up settings employing Residual Sensing are given in Table 2.2. Figure 2.5 shows a 4-pole breaker with Residual Ground Fault Sensing.



## CAUTION

**IF THE SENSOR CONNECTIONS ARE INCORRECT, A NUISANCE TRIP MAY OCCUR. ALWAYS OBSERVE THE POLARITY MARKINGS ON THE INSTALLATION DRAWINGS. TO INSURE CORRECT GROUND FAULT EQUIPMENT PERFORMANCE, CONDUCT FIELD TESTS TO COMPLY WITH NEC REQUIREMENTS UNDER ARTICLE 230-95(C).**

### 2.3.3 Source Ground Sensing

Depending upon the installation requirements, alternate ground fault sensing schemes may be dictated (see Figures 2.6 and 2.7). The ground return method is usually applied when ground fault protection is desired only on the main circuit breaker in a simple radial system. This method is also applicable to double-ended systems where a mid-point grounding electrode is employed. For this mode of sensing, a single current sensor mounted on the equipment-bonding jumper directly measures the total ground current flowing in the grounding electrode conductor and all other equipment-grounding conductors.

The settings shown in Table 2.1 will apply when the neutral sensor is not the same as the frame rating in a ground return sensing scheme.

### 2.3.4 Zero Sequence Sensing

Zero Sequence Sensing, also referred to as vectorial summation (see Figure 2.8), is applicable to mains, feeders, and special schemes involving zone protection. Zero Sequence current transformers (4 1/2" x 13 1/2" [114 mm x 342 mm] rectangular inside dimensions) are available with 100:1 and 1000:1 ratios.

### 2.3.5 Multiple Source/Multiple Ground

A Multiple Source/Multiple Ground scheme is shown in Figure 2.9. In this figure, a ground fault is shown which has two possible return paths, via the neutral, back to its source. The three neutral sensors are interconnected to sense and detect both ground fault and neutral currents.

Call Cutler-Hammer for more details on this scheme.

### 2.3.6 Ground Fault Settings

The adjustment of the ground fault functional settings (FLAT response or  $I^2t$ ) is discussed in Section 4.8. The effect of these settings is illustrated in the ground fault time-current curve referenced in Section 9. Applicable residual ground fault pick-up settings and current values are given in Table 2.2 as well as in the ground time-current curve.

Table 2.2 Ground (Earth) Fault Current Settings

Ground Fault Current Settings (Amperes) <sup>1</sup>								
Installed Sensor/ Rating Plug (Amperes) /n	.25	.30	.35	.40	.50	.60	.75	1.0
200	50	60	70	80	100	120	150	200
250	63	75	88	100	125	150	188	250
300	75	90	105	120	150	180	225	300
400	100	120	140	160	200	240	300	400
600	150	180	210	240	300	360	450	600
630	158	189	221	252	315	378	473	630
800	200	240	280	320	400	480	600	800
1000	250	300	350	400	500	600	750	1000
1200	300	360	420	480	600	720	900	1200
1250	312	375	438	500	625	750	938	1250
1600	400	480	560	640	800	960	1200	1600 <sup>2</sup>
2000	500	600	700	800	1000	1200	1500 <sup>2</sup>	2000 <sup>2</sup>
2500	625	750	875	1000	1250	1500	1875	2500
3000	750	900	1050	1200	1500 <sup>2</sup>	1800 <sup>2</sup>	2250 <sup>2</sup>	3000 <sup>2</sup>
3200	800	960	1120	1200	1600 <sup>2</sup>	1920 <sup>2</sup>	2400 <sup>2</sup>	3200 <sup>2</sup>
4000 <sup>3</sup>	1000	1200	1400 <sup>2</sup>	1600 <sup>2</sup>	2000 <sup>2</sup>	2400 <sup>2</sup>	3000 <sup>2</sup>	4000 <sup>2</sup>
5000 <sup>3</sup>	1250 <sup>2</sup>	1500 <sup>2</sup>	1750 <sup>2</sup>	2000 <sup>2</sup>	2500 <sup>2</sup>	3000 <sup>2</sup>	3750 <sup>2</sup>	5000 <sup>2</sup>
6300 <sup>3</sup>	1575	1890	2205	2520	3150	3780	4725	6300

1. Tolerance on settings are  $\pm 10\%$  of values shown.  
2. On Models 520 LSIG and 520M LSIG, the shaded values are set to a maximum trip value of 1200 amperes for NEC.  
3. See Section 2.5.

## 2.4 Current Sensors (Magnum Frames less than or equal to 3200A)

The three (3-pole) or four (4-pole) primary current sensors are installed internally in the circuit breaker on the lower conductors of the breaker. The current sensor rating defines the breaker rating ( $I_n$ ). For example, 2000A:1A sensors are used on a 2000A rated breaker. There are four auxiliary current transformers with a ratio of 10:1 which further step down the rated current to 100 milliamperes, which is equivalent to 100% ( $I_n$ ) to the Digitrip.

The primary current sensors produce an output proportional to the load current and furnish the Digitrip DT20 family with the information and energy required to trip the circuit breaker when functional protection settings are exceeded.

If a set of current sensors with a different ratio are installed in the field, the rating plug must also be changed. The associated rating plug must match the current sensor

rating specified on the plug label. The current sensor rating can be viewed through openings in the back of the breaker.

## 2.5 Current Sensors (Magnum Frames greater than 3200A)

The six (3-pole) or eight (4-pole) current sensors installed in the circuit breaker are located on the lower conductors. The poles are paralleled and the corresponding current sensors are also paralleled (see Figure 2.3). For example, a 4000A breaker phase rating has two 2000:1 current sensors wired in parallel, which provides an overall ratio of 4000:2. The auxiliary current transformers have a ratio of 20:1 for this size breaker which further steps down the rated current to 100 milliamperes and is equivalent to 100% ( $I_n$ ) to the Digitrip.

## 3.0 PRINCIPLES OF OPERATION

### 3.1 General

The Digitrip DT20 family of trip units is designed for industrial circuit breaker environments where the ambient temperatures can range from  $-20^\circ\text{C}$  to  $+85^\circ\text{C}$  but rarely exceed  $70^\circ$  to  $75^\circ\text{C}$ . If, however, temperatures in the neighborhood of the trip unit exceed this range, the trip unit performance may be degraded. In order to insure that the tripping function is not compromised due to an over-temperature condition, the Digitrip 520 family microcomputer chip has a built-in over-temperature protection feature, factory set to trip the breaker if the chip temperature is excessive. On the 520 family, if over-temperature is the reason for the trip the red Long Delay Time LED will flash.

The Digitrip uses the Cutler-Hammer custom-designed SURE+chip™, an integrated circuit that includes a microcomputer to perform its numeric and logic functions. The principles of operation of the trip unit are shown in Figure 3.1.

In the Digitrip DT20 family of trip units, all sensing and tripping power required to operate the protection function is derived from the current sensors in the circuit breaker. The secondary currents from these sensors provide the correct input information for the protection functions, as well as tripping power, whenever the circuit breaker is carrying current. These current signals develop analog voltages across the current viewing resistors. The resulting analog voltages are digitized by the SURE+chip™.

The microcomputer continually digitizes these signals. This data is used to calculate true RMS current values, which are then continually compared with the protection function settings and other operating data stored in the

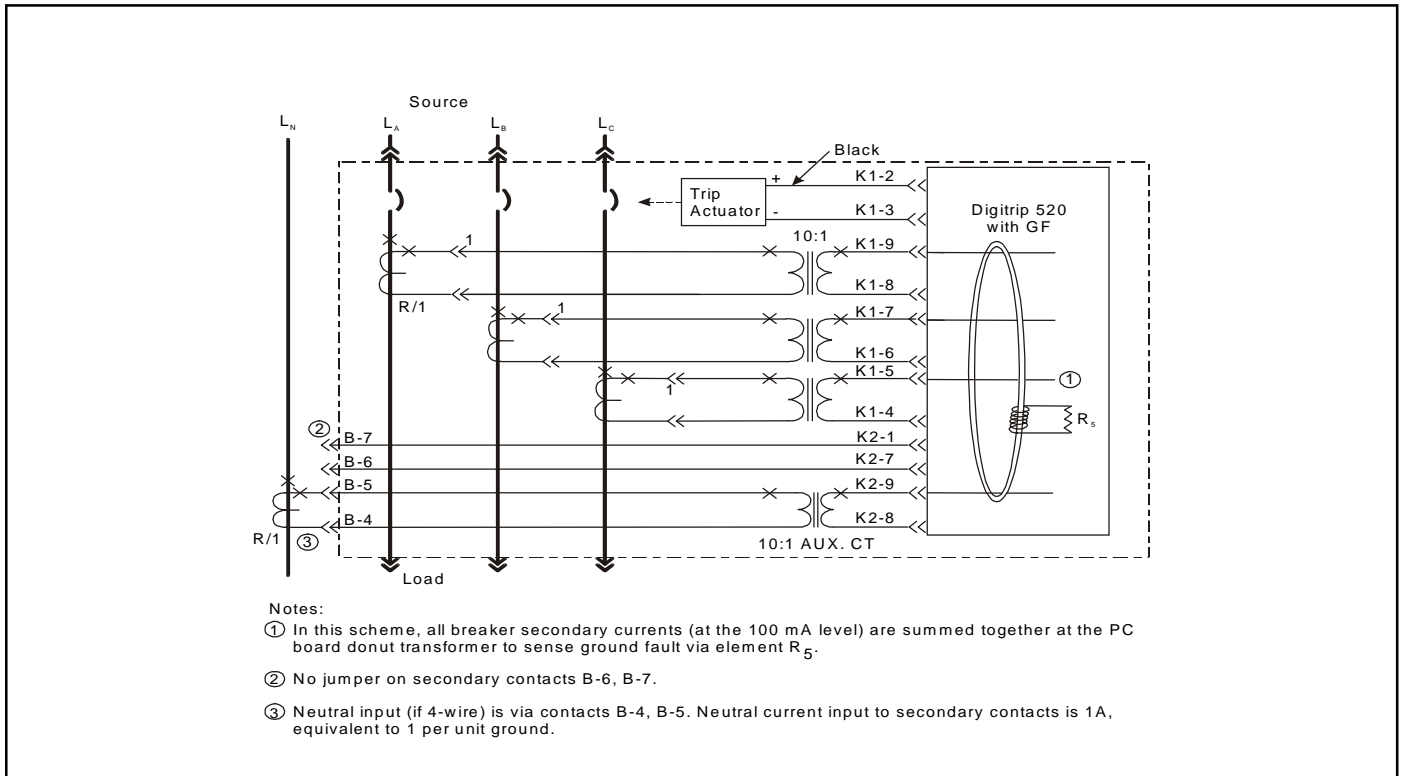

Figure 2.2 3-Pole, 4-Wire Breaker with Neutral Sensor Connections for 3200A Frame Using Residual GF Sensing

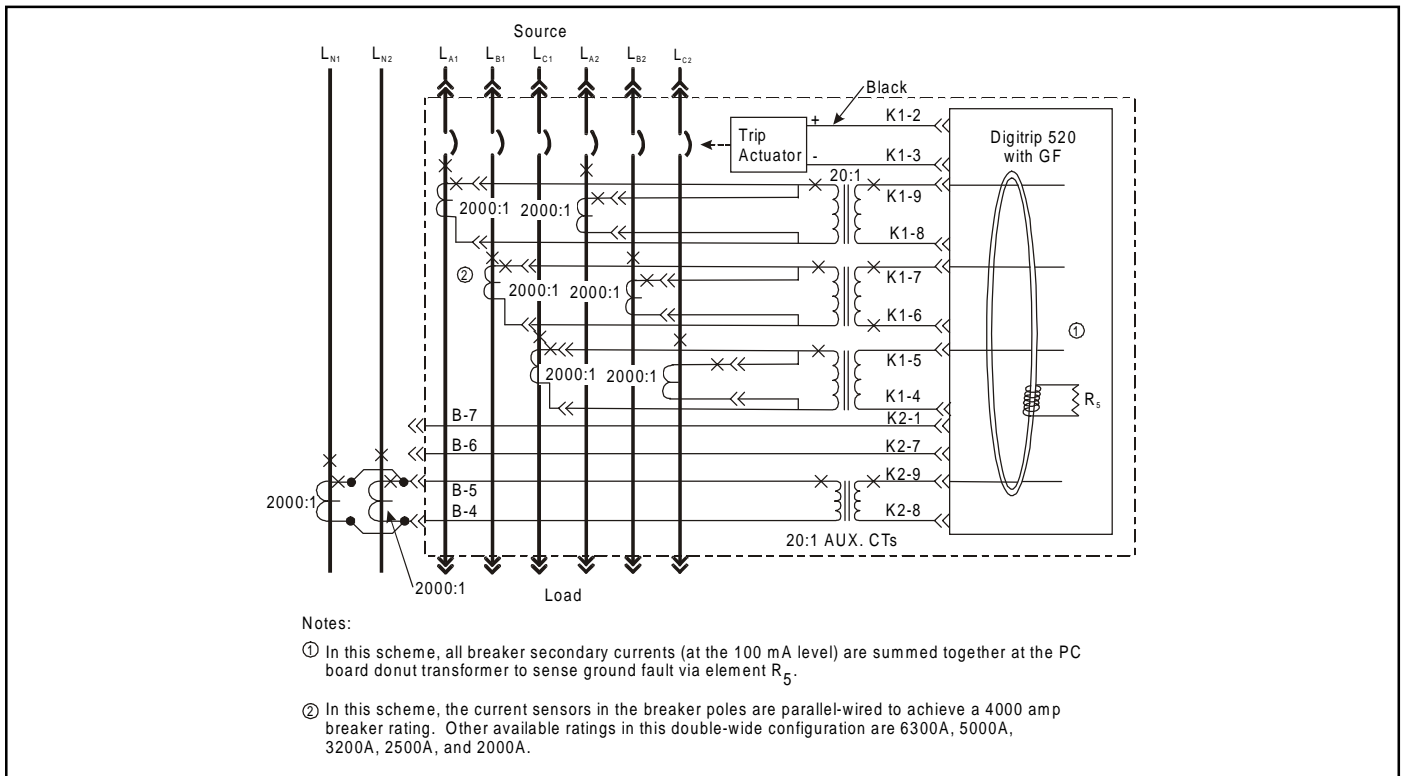

Figure 2.3 Neutral Sensor Connections for 4000A Frame Using Residual Ground Fault Sensing

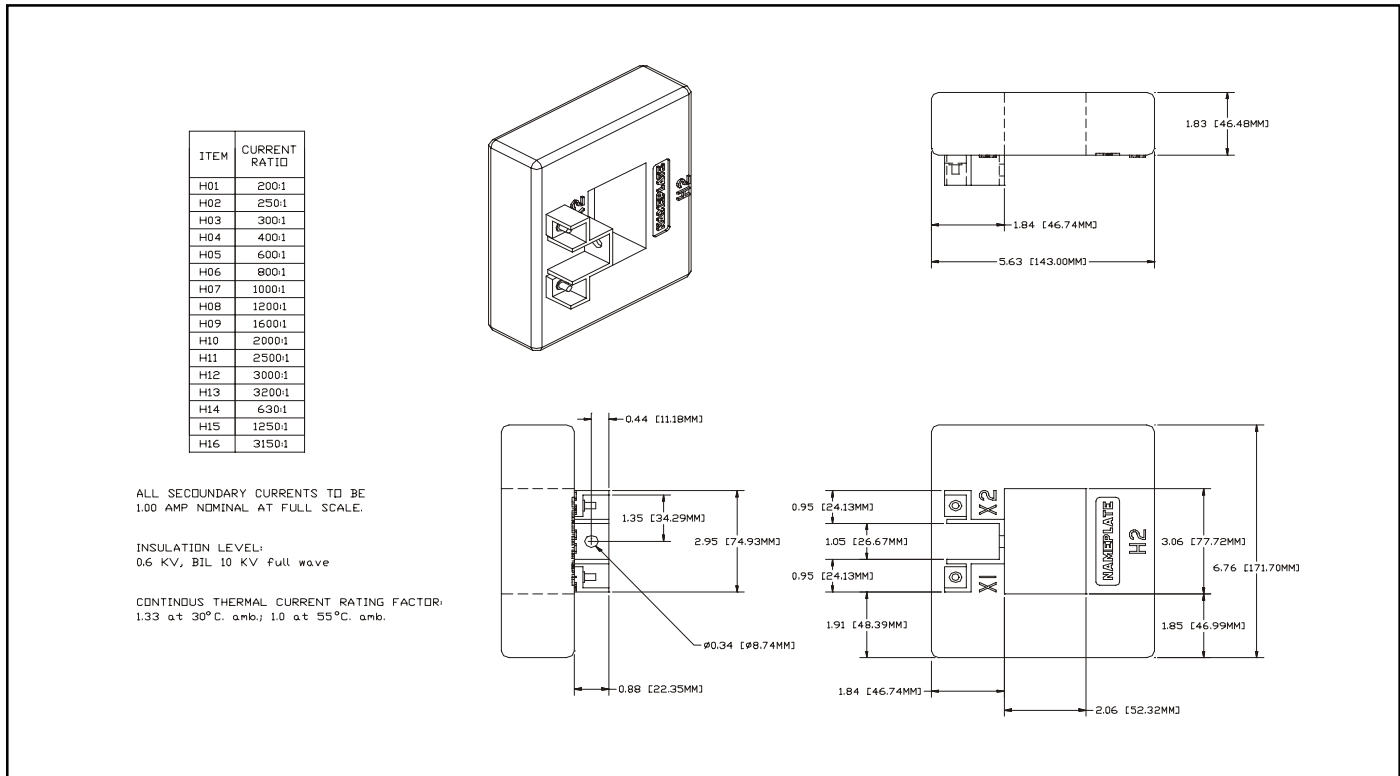

Figure 2.4 Digitrip Neutral Sensor Types

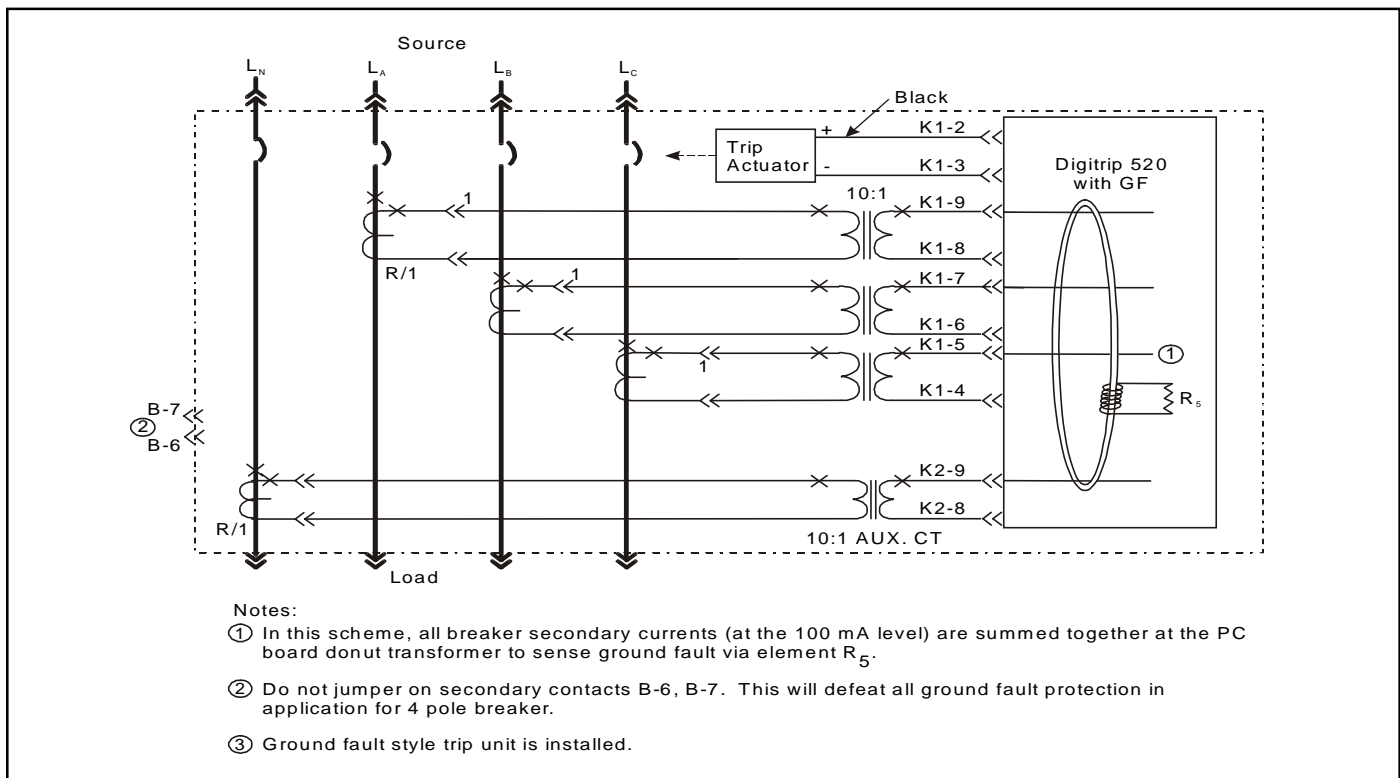

Figure 2.5 4-Pole-3200A Frame Using Residual Ground Fault (Earth-Fault) Sensing

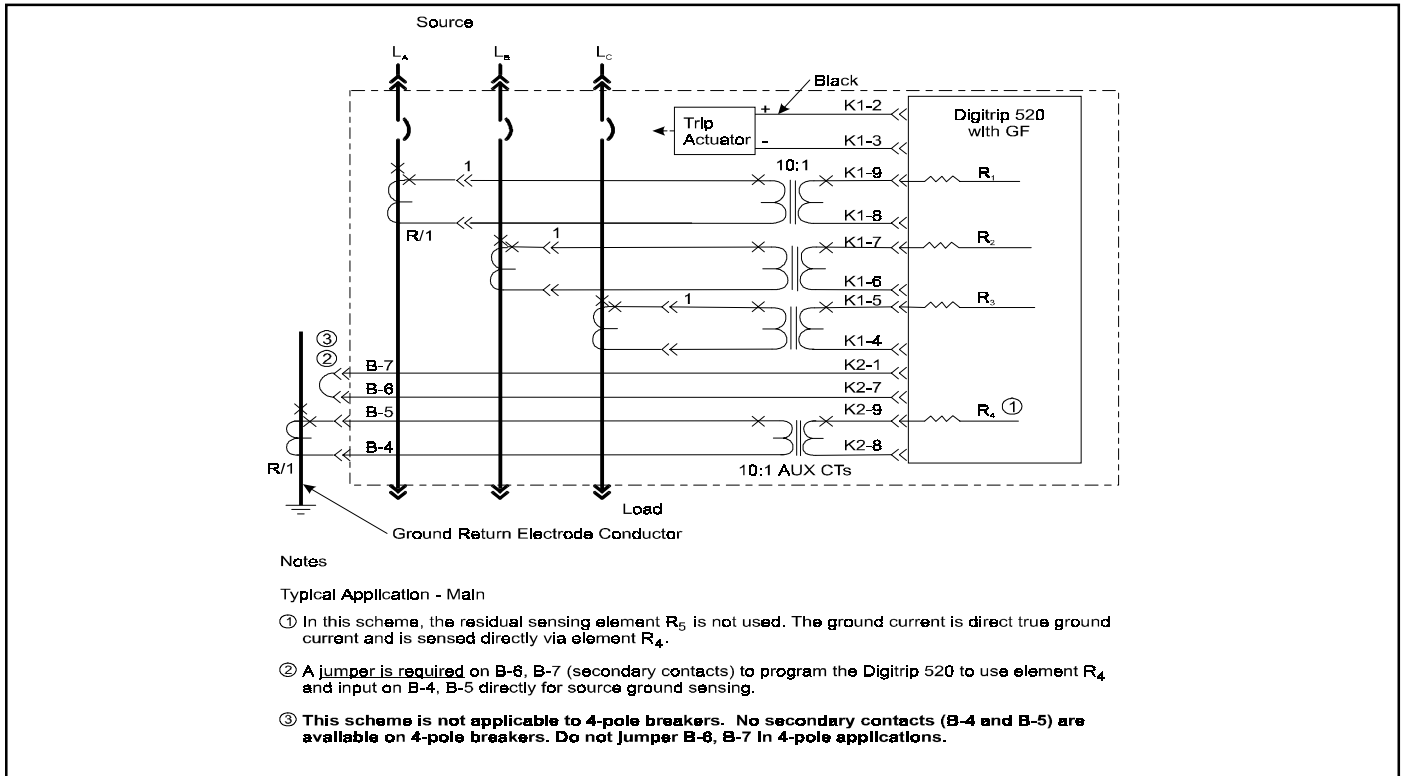

Figure 2.6 Source Ground Fault Sensing Scheme for 3200A Frame

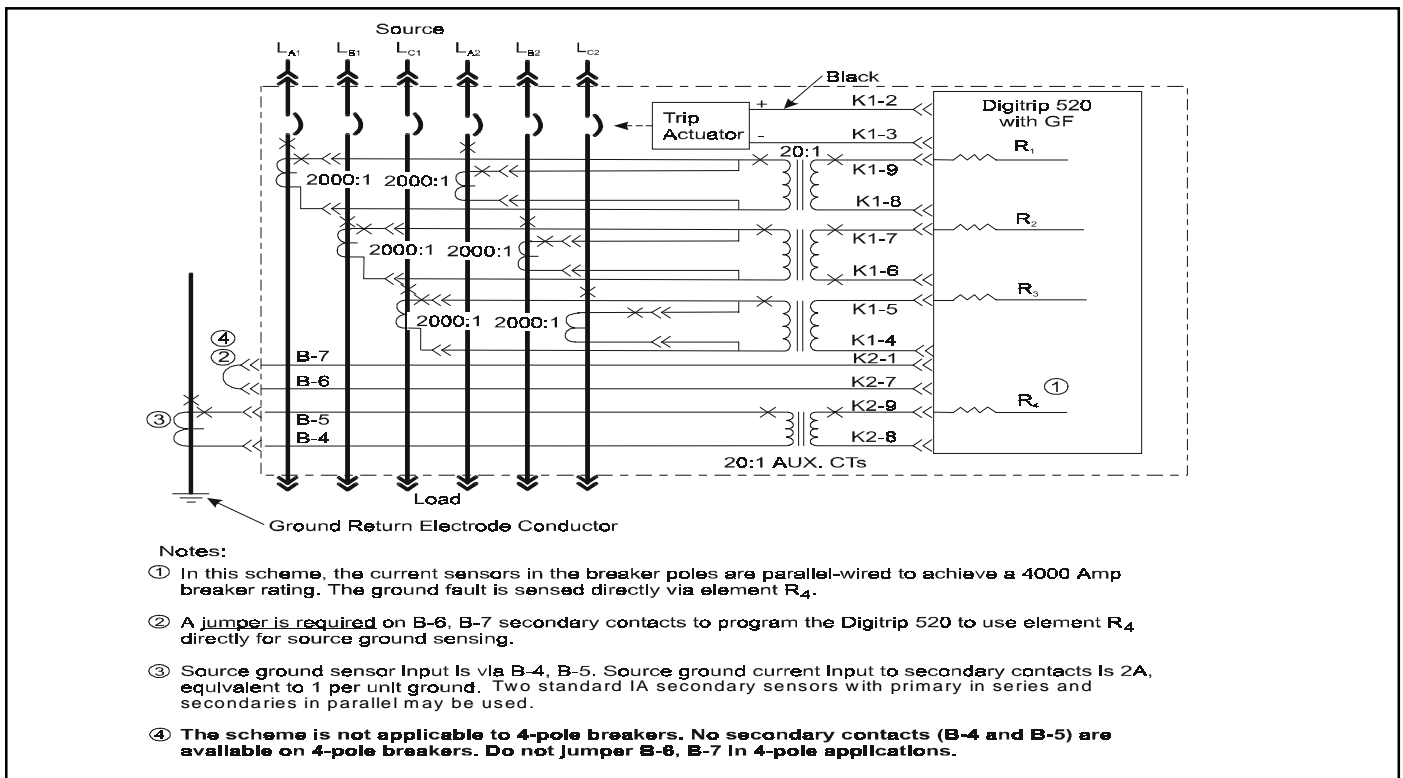

Figure 2.7 Source Ground Fault Sensing Scheme for 4000A Frame



memory. The embedded software then determines whether to initiate protection functions, including tripping the breaker through the Trip Actuator.

### 3.2 Trip and Operation Indicators

The LEDs on the face of the trip unit, shown in Figures 1.1 and 3.3 to 3.9, flash red to indicate the reason for any automatic trip operation. Each LED is strategically located in the related segment of the time-current curve depicted on the face of the trip unit. The reason for the trip is identified by the segment of the time-current curve where the LED is illuminated. Following an automatic trip operation, the backup battery continues to supply power to the LEDs as shown in Figure 3.1. The LED pulse circuit, shown in Figure 3.1, is provided to reduce battery burden and will supply a quick flash of the trip LED approximately every 4 seconds. It is therefore important to view the unit for at least 5 seconds to detect a flashing cause of trip indicator.

Following a trip operation, push the Reset/Battery Test button, shown in Figure 1.1, to turn off the LEDs.

A green LED, shown in Figure 1.1, indicates the operational status of the trip unit. Once the load current through the circuit breaker exceeds approximately 10 percent (3 phase power) of the current sensor rating, the green LED will flash on and off once each second to indicate that the trip unit is energized and operating properly.

**NOTE:** A steady green status LED typically indicates that a low level of load current, on the order of 5% of full load, exists.

### 3.3 Making Current Release

All Digitrip DT20 Trip Units have a Making Current Release function. This safety feature prevents the circuit breaker from being closed and latched-in on a faulted circuit. The nonadjustable release is preset at to a peak current of  $25 \times I_n$  which correlates to approximately  $11 \times I_n$  (rms) with maximum asymmetry.

The Making Current Release is enabled only for the first two cycles following an initial circuit breaker closing operation. The Making Current Release will trip the circuit breaker instantaneously and flash the Instantaneous LED.

### 3.4 Zone Interlocking (520 family only)



**IF ZONE INTERLOCKING IS NOT TO BE USED (I.E., ONLY STANDARD TIME-DELAY COORDINATION IS INTENDED), THE ZONE INTERLOCKING TERMINALS MUST BE CONNECTED BY A JUMPER FROM TERMINAL B8 TO B9 OF THE BREAKER SECONDARY TERMINALS SO THAT THE TIME-DELAY SETTINGS WILL PROVIDE THE INTENDED COORDINATION.**

Zone Selective Interlocking (or Zone Interlocking) is available for the Digitrip 520 family on the Short Delay and Ground Fault protection functions (see Figure 3.1). The zone interlocking signal is wired via a single set of wires labeled Zone In (Zin) and Zone Out (Zout) along with a Zone Common wire. The Zone Selective Interlocking function on the Digitrip 520 family has combined the logic interlocking of Short Delay and Ground Fault. A zone out signal is sent whenever the ground fault pick-up is exceeded or when the short delay value of  $2 \times (I_r)$  is exceeded. Zone Selective Interlocking provides the fastest possible tripping for faults within the zone of protection of the breaker and yet also provides positive coordination among all breakers in the system (mains, ties, feeders, and downstream breakers) to limit a power outage to only the affected parts of the system. When Zone Interlocking is employed, a fault within the zone of protection of the breaker will cause the Digitrip 520 family of units to:

- Trip the affected breaker immediately and, at the same time,
- Send a signal to upstream Digitrip units to restrain from tripping immediately. The restraining signal causes the upstream breakers to follow their set coordination times, so that the service is only minimally disrupted while the fault is cleared in the shortest time possible.

For an example of how Zone Selective Interlocking may be used, see Appendix A of this Instructional Leaflet.

Figure 3.1 Digitrip DT20 Block Diagram with Breaker Interface

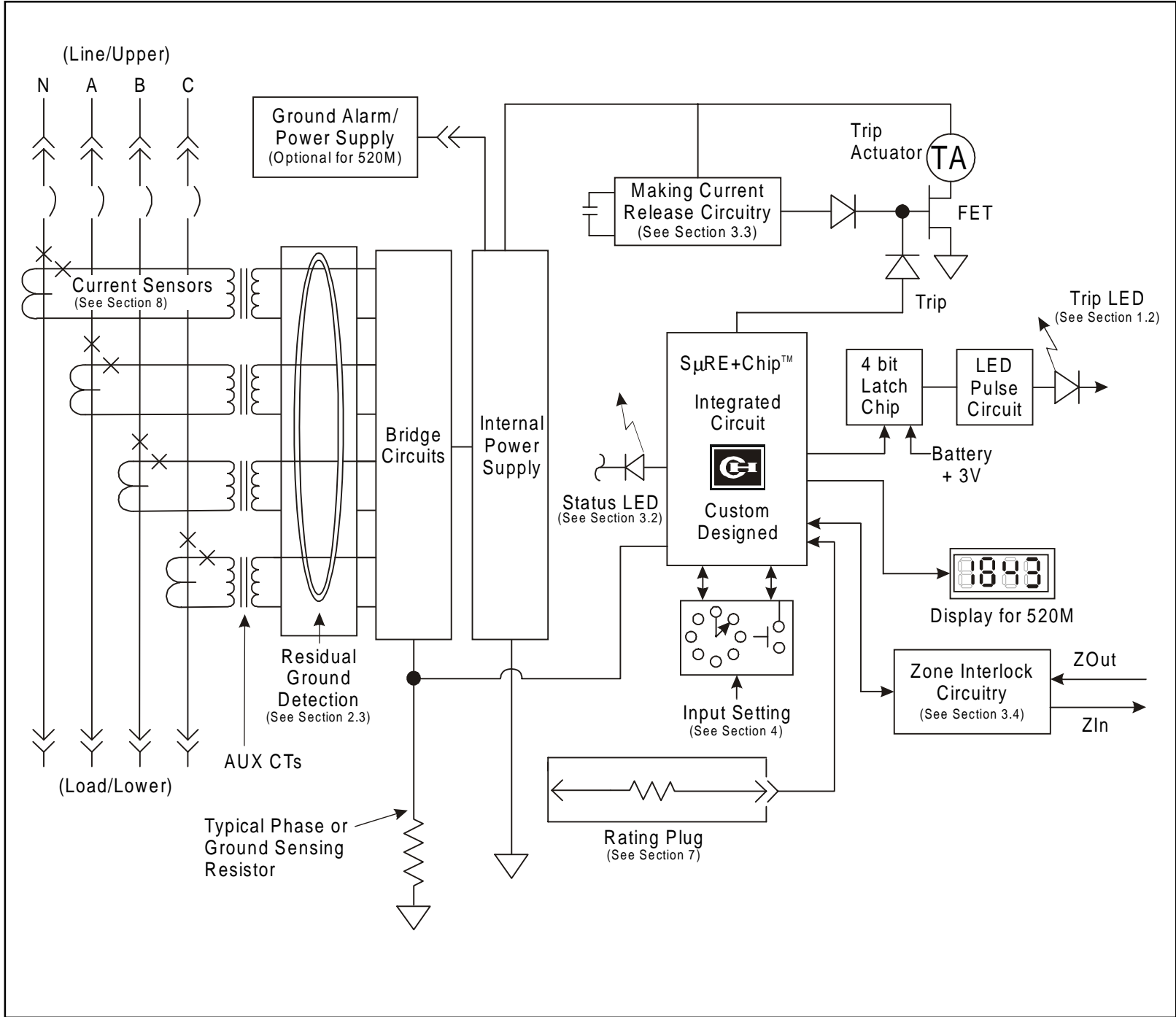

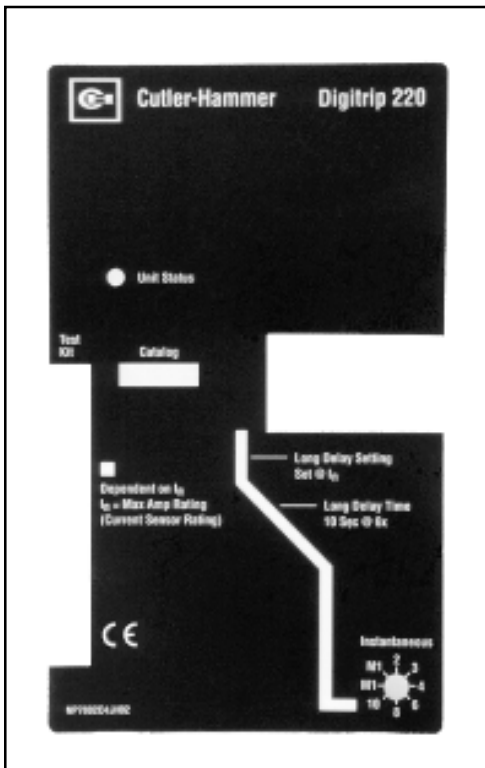

Figure 3.2 Digitrip 220 LSI

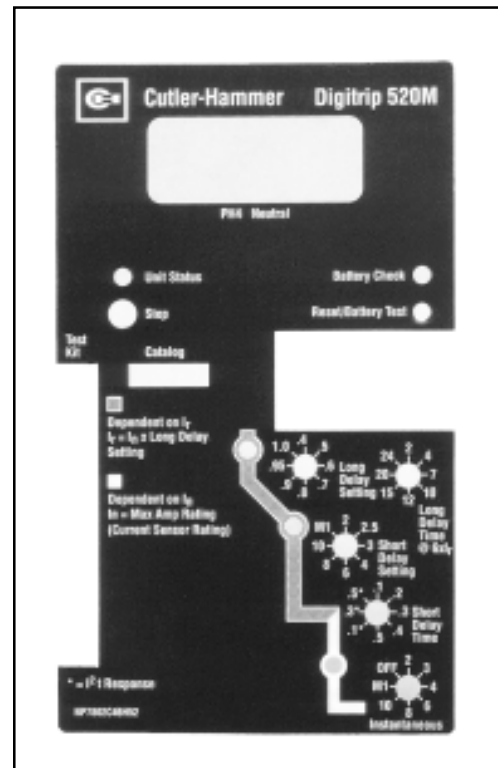

Figure 3.3 Digitrip 520 LSI

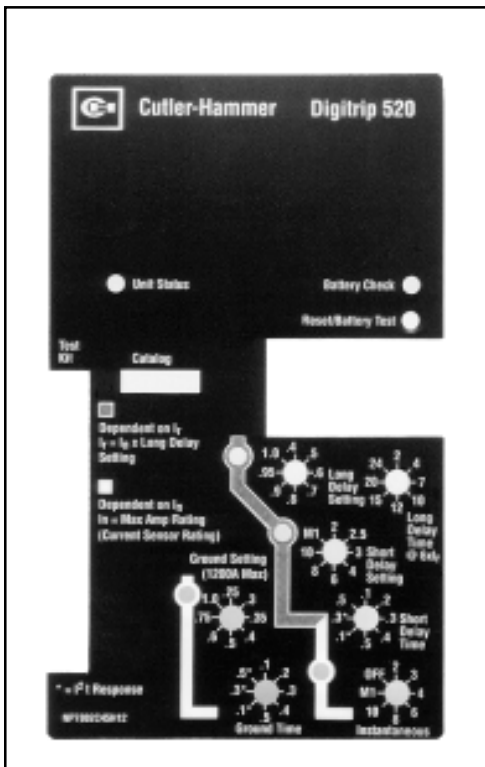

Figure 3.4 Digitrip 520 LSIG

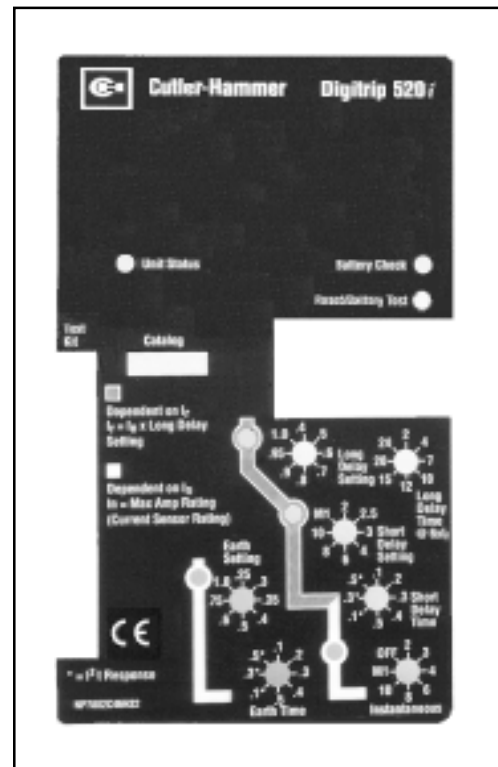

Figure 3.5 Digitrip 520i WLSIG

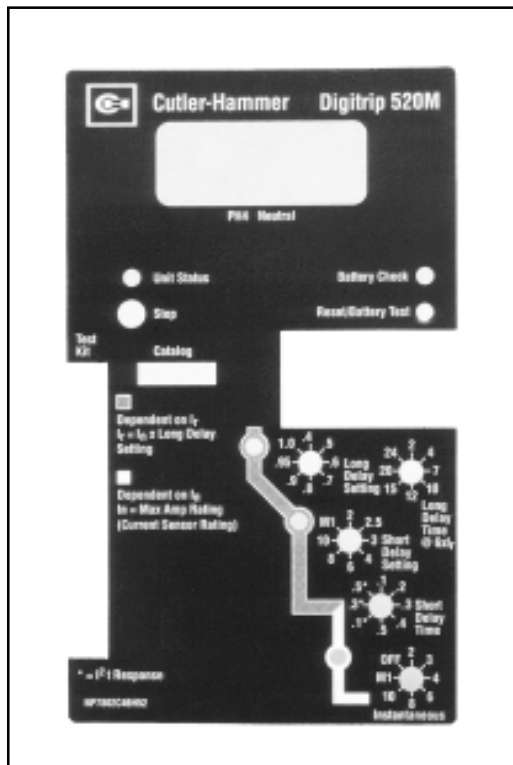

Figure 3.6 Digitrip 520M MLSI

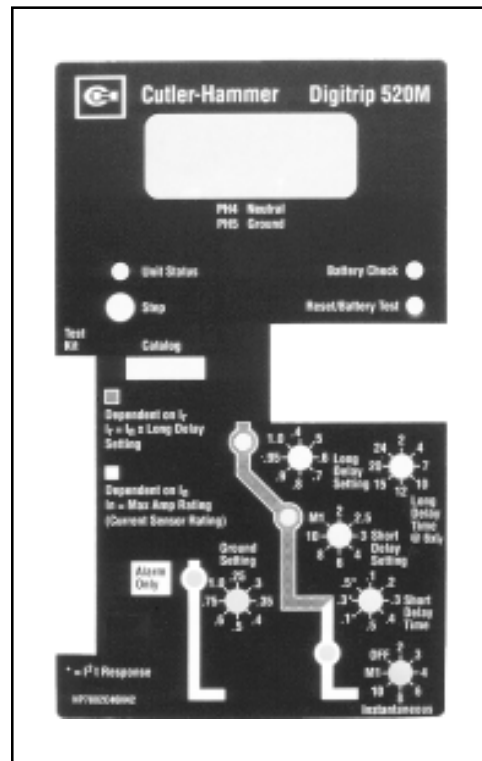

Figure 3.7 Digitrip 520M MLSIA

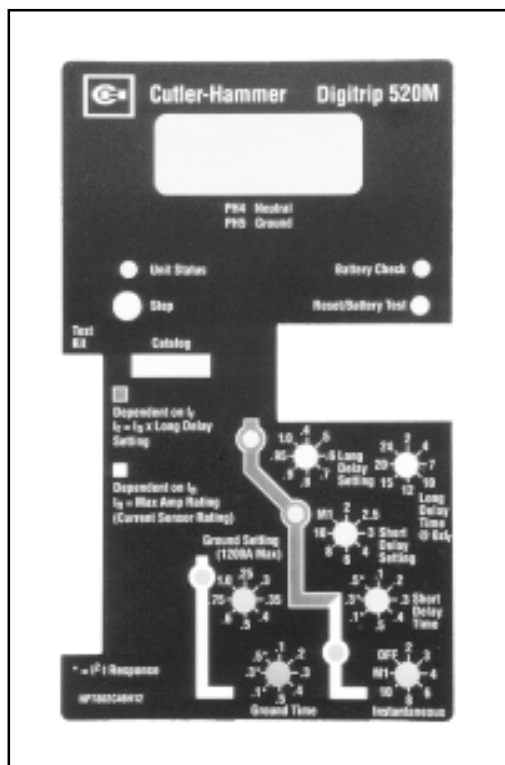

Figure 3.8 Digitrip 520M MLSIG

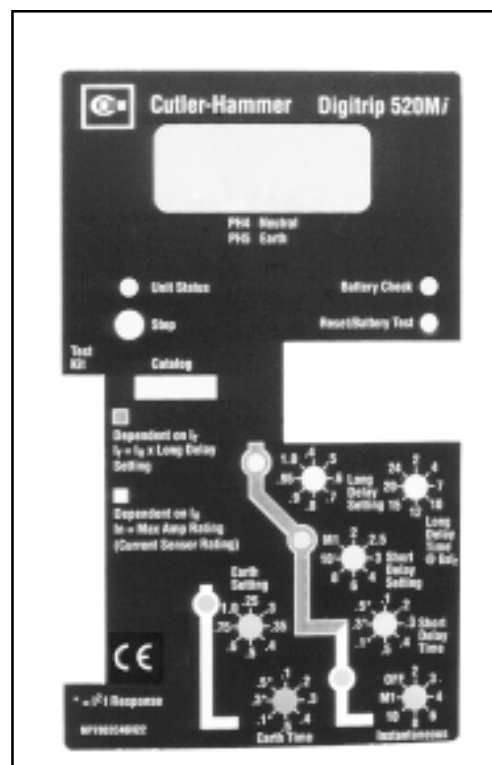

Figure 3.9 Digitrip 520Mi MWLSIG

### 4.0 PROTECTION SETTINGS

#### 4.1 General

Before placing any circuit breaker in operation, set each trip unit protection setting to the values specified by the engineer responsible for the installation. The number of settings that must be made is determined by the type of protection supplied by each unit, as illustrated in Figures 3.2 through 3.9. Each setting is made by turning a rotary switch, using a small screwdriver. The selected setting for each adjustment appears on the trip unit label.

The installed rating plug must match the current sensors which establish the maximum continuous current rating of the circuit breaker ( $I_n$ ). Instantaneous and ground current settings are defined in multiples of ( $I_n$ ).

To illustrate the effect of each protection curve setting, simulated time-current curves are pictured on the face of the trip unit. Each rotary switch is located nearest the portion of the simulated time-current curve that it controls. Should an automatic trip occur (as a result of the current exceeding the pre-selected value), the LED in the appropriate segment of the simulated time-current curve will light red, indicating the reason for the trip.

The available settings, along with the effects of changing the settings, are given in Figures 4.1 through 4.8. Sample settings are represented in boxes (2).

#### 4.2 Long Delay Current Setting

There are 8 available Long Delay Settings, as illustrated in Figure 4.1. Each setting, called ( $I_r$ ), is expressed as a multiple (ranging from .4 to 1) of the current ( $I_n$ ).

**NOTE:** ( $I_r$ ) is also the basis for the Short Delay Current Setting (see Section 4.4).

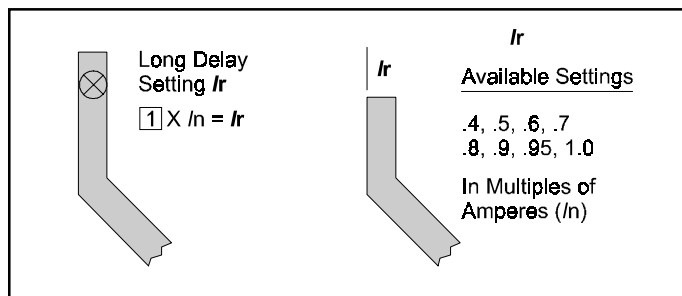

Figure 4.1 Long Delay Current Settings

#### 4.3 Long Delay Time Setting

There are 8 available Long Delay Time Settings, as illustrated in Figure 4.2, ranging from 2 to 24 seconds. These settings are the total clearing times when the current value equals 6 times ( $I_r$ ).

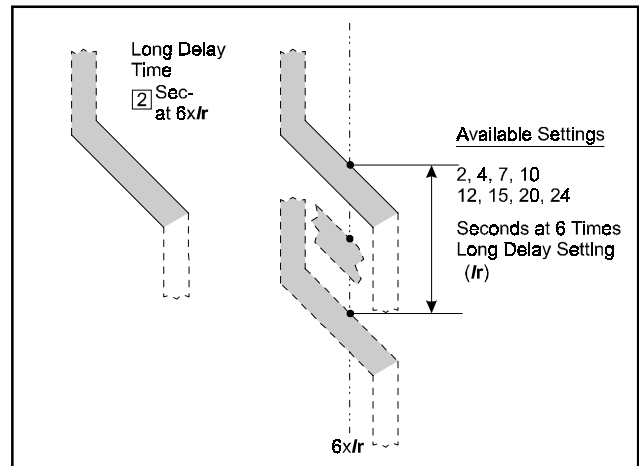

Figure 4.2 Long Delay Time Settings

**NOTE:** In addition to the standard Long Delay Protection Element, the DT20 family of trip units also has a Long Time Memory (LTM) function, which protects load circuits from the effects of repeated overload conditions. If a breaker is reclosed soon after a Long Delay Trip, and the current again exceeds the Long Delay Setting, ( $I_r$ ), the LTM automatically reduces the time to trip to allow for the fact that the load circuit temperature is already higher than normal because of the prior overload condition. Each time the overload condition is repeated, the LTM causes the breaker to trip in a progressively shorter time. When the load current returns to normal, the LTM begins to reset; after about 10 minutes it will have reset fully, so the next Long Delay trip time will again correspond to the Setting value.

**NOTE:** In certain applications, it may be desirable to disable the LTM function. Open the test port located at the lower left-hand front of the trip unit and use small, long-nose pliers to move the LTM jumper inside the test port (see Figure 4.3) to its Inactive position. (The LTM function can be enabled again at any time by moving the LTM jumper back to its original Active position.)

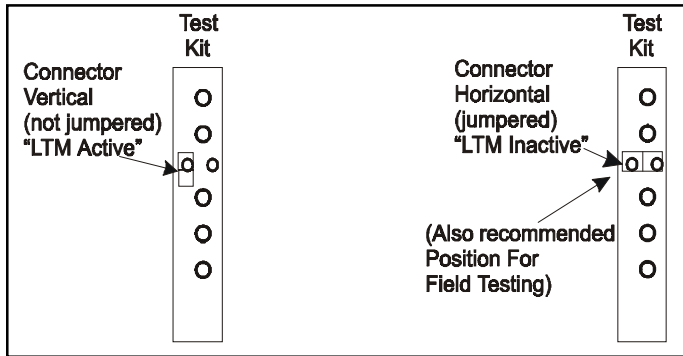

Figure 4.3 Long Time Memory (LTM) Jumper

The action of the LTM must be considered when performing multiple Long Delay Time tests (see Section 5.4).

#### 4.4 Short Delay Current Setting

There are 8 available Short Delay Current Settings, as illustrated in Figure 4.4. Seven settings are in the range from 2 to 10 times ( $I_r$ ). (*REMEMBER: ( $I_r$ ) is the Long Delay Current Setting.*) The maximum value M1 is based on the ampere rating of the circuit breaker and is listed in Note 4 of Table 1.1.

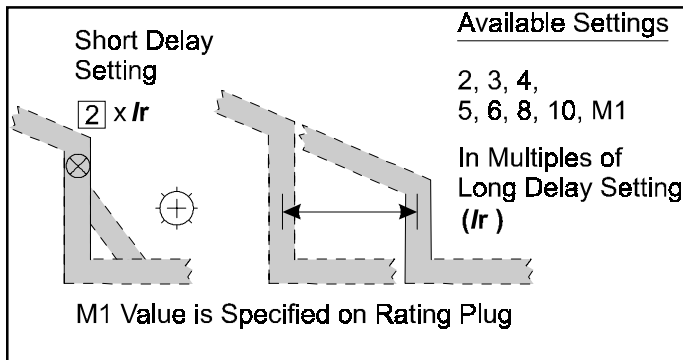

Figure 4.4 Short Delay Current Settings

#### 4.5 Short Delay Time Setting

As illustrated in Figure 4.5, there are two different Short Delay response curve shapes: fixed time (FLAT) and  $I^2t$ . The shape selected depends on the type of selective coordination chosen. The  $I^2t$  response curve will provide a longer time delay for current below  $8 \times I_r$  than will the FLAT response curve.

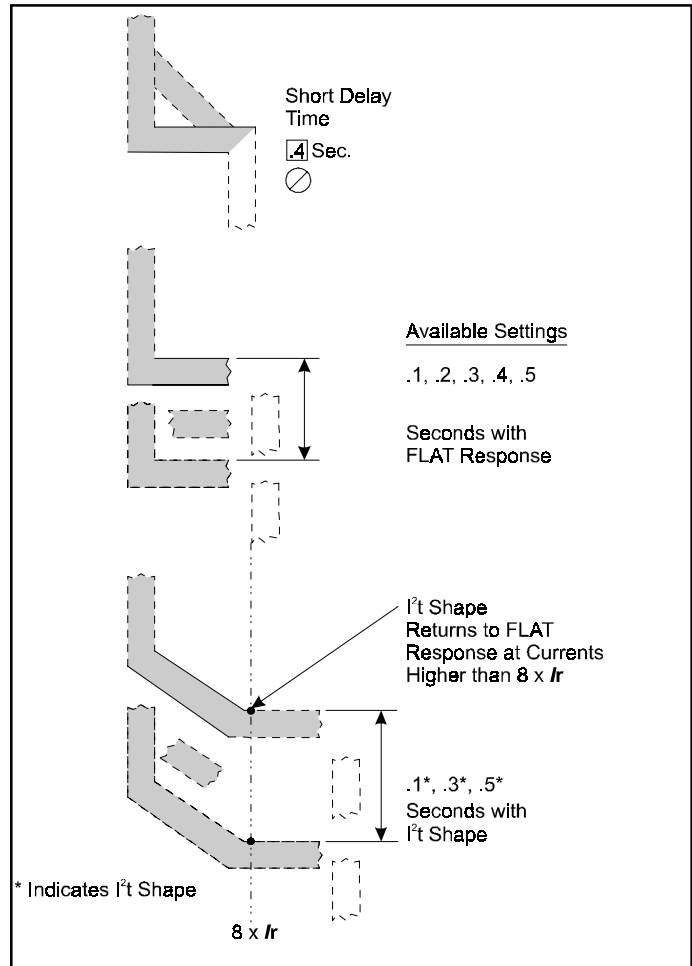

Figure 4.5 Short Delay Time Settings

Five FLAT (.1, .2, .3, .4, .5 seconds) and three  $I^2t$  (.1\*, .3\*, .5\* seconds) response time delay settings are available. The  $I^2t$  response settings are identified by an asterisk (\*). The  $I^2t$  response is applicable to currents less than 8 times the ampere rating of the installed rating plug ( $I_r$ ). For currents greater than  $8 \times I_r$  the  $I^2t$  response reverts to the FLAT response.

**NOTE:** Also see Section 3.4, Zone Interlocking.

#### 4.6 Instantaneous Current Setting

There are 8 available Instantaneous Current Settings, as illustrated in Figure 4.6. Six settings are in the range from 2 to  $10 \times I_n$  the rating plug value, and the other two settings are  $M1 \times I_n$  or Off. The value that M1 has depends upon the sensor rating of the circuit breaker and is specified both on the rating plug label and on the applicable time-current curves referenced in Section 9.

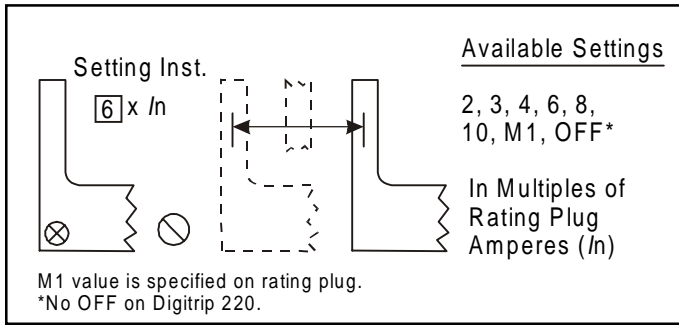

Figure 4.6 Instantaneous Current Settings

4.7 Ground Fault Current Setting

The 8 Ground Fault Current Settings are labeled with values from .25 to 1.0 x (In) (see Figure 4.7). The domestic (U.S.) models have a maximum of 1200A, limited by the firmware of the unit, as shown in Table 1.1 and Table 2.2. The specific Ground Current Settings for each model are listed in Table 2.2 and on the applicable time-current curve for the breaker.

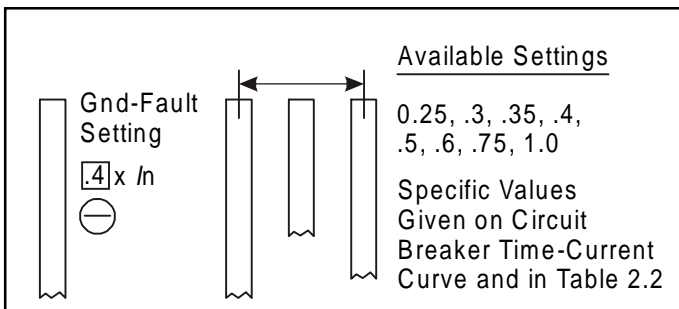

Figure 4.7 Ground Fault Current Settings

4.8 Ground Fault Time Delay Setting

As illustrated in Figure 4.8, there are two different Ground Fault curve shapes: fixed time (FLAT) or I<sup>2</sup>t response. The shape selected depends on the type of selective coordination chosen. The I<sup>2</sup>t response will provide a longer time delay for current below 0.625 x In than will the FLAT response.

Five FLAT (.1, .2, .3, .4, .5 seconds) and three I<sup>2</sup>t (.1\*, .3\*, .5\* seconds) response time delay settings are available. The I<sup>2</sup>t response settings are identified by an asterisk (\*). The I<sup>2</sup>t response is applicable to currents less than 0.625 times the ampere rating of the installed rating plug (In). For currents greater than 0.625 x (In) the I<sup>2</sup>t response reverts to the FLAT response.

**NOTE:** Also see Section 3.4, Zone Interlocking.

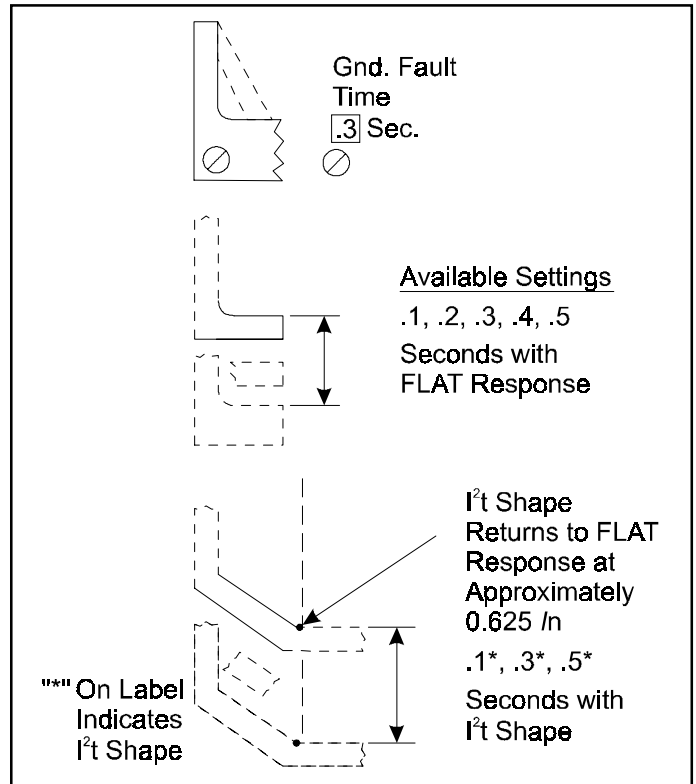

Figure 4.8 Ground Fault Time Delay Settings

5.0 TEST PROCEDURES

5.1 General



**DO NOT ATTEMPT TO INSTALL, TEST, OR PERFORM MAINTENANCE ON EQUIPMENT WHILE IT IS ENERGIZED. DEATH OR SEVERE PERSONAL INJURY CAN RESULT FROM CONTACT WITH ENERGIZED EQUIPMENT.**

**DE-ENERGIZE THE CIRCUIT AND DISCONNECT THE CIRCUIT BREAKER BEFORE PERFORMING MAINTENANCE OR TESTS.**



**ANY TRIPPING OPERATION WILL CAUSE DISRUPTION OF SERVICE AND POSSIBLE PERSONAL INJURY, RESULTING IN THE UNNECESSARY SWITCHING OF CONNECTED EQUIPMENT.**

**CAUTION**

**TESTING A CIRCUIT BREAKER WHILE IT IS IN-SERVICE AND CARRYING LOAD CURRENT IS *NOT* RECOMMENDED.**

**TESTING OF A CIRCUIT BREAKER THAT RESULTS IN THE TRIPPING OF THE CIRCUIT BREAKER SHOULD BE DONE ONLY WITH THE CIRCUIT BREAKER IN THE TEST OR DISCONNECTED CELL POSITIONS OR WHILE THE CIRCUIT BREAKER IS ON A TEST BENCH.**

### 5.2 When to Test

Testing prior to start-up can best be accomplished with the breaker out of its cell or in the Test, Disconnected, or Withdrawn (or Removed) cell positions.

**NOTE:** Since time-current settings are based on desired system coordination and protection schemes, the protection settings selected and preset in accordance with Section 4 should be reset to their as-found conditions if altered during any routine test sequence.

### 5.3 Functional Field Testing

**CAUTION**

**PERFORMING TESTS WITHOUT THE CUTLER-HAMMER-APPROVED TEST KIT MAY DAMAGE THE DIGITRIP UNIT.**

Use the test receptacle to verify a functional load test of a major portion of the electronic circuitry of the Digitrip and the mechanical trip assembly of the breaker. The testing can determine the accuracy of the desired trip settings by performing Long Delay, Short Delay, and Ground Fault functional tests. The Cutler-Hammer-approved test kit is listed below.

Model	Test Kit
Digitrip DT20 family	Test Kit (140D481G02R, 140D481G02RR, 140D481G03, or G04) with Test Kit Adapter 8779C02G04

The test port is located on the front left-hand corner of the DT20 units (see Figure 1.1). To access the port, remove the plexiglass cover from the front of the circuit breaker. Using a small screwdriver, gently pry up on the test port cover to remove this item.

**CAUTION**

**BEFORE PLUGGING A TEST KIT INTO THE TEST PORT, PLACE THE LTM JUMPER IN THE INACTIVE POSITION (SEE FIGURE 4.3). AFTER TESTING, RETURN THE LTM JUMPER TO ITS ORIGINAL POSITION.**

The test kit authorized by Cutler-Hammer for use with the Digitrip units plugs into the test port of the unit and provides a secondary injection test that simulates the current transformer. Existing test kits, styles 140D481G02R, 140D481G02RR, 140D481G03 or G04, along with the Magnum Test Kit Adapter 8779C02G04, can be used to test the trip unit and breaker.

### 5.4 Performance Testing for Ground Fault Trip Units

#### 5.4.1 Code Requirements

The NEC, under Article 230-95-C, requires that any ground fault protection system be performance tested when first installed. Conduct tests in accordance with the approved instructions provided with the equipment. Make a written record of this test and make the results available to the authority having inspection jurisdiction.

#### 5.4.2 Standards Requirements

As a follow-up to the basic performance requirements stipulated by the NEC, UL Standard No. 1053 requires that certain minimum instructions must accompany each ground fault protection system. These statements (Section 5.4.3), plus a copy of the record forms (Figures 8.1, 8.2, and 8.3), are included as part of this Instructional Leaflet.

#### 5.4.3 General Test Instructions

The interconnected system must be evaluated only by qualified personnel and in accordance with the equipment assembler's detailed instructions.

To avoid improper operations following apparently correct simulated test operations, the polarity of the neutral sensor connections (if used) must agree with the equipment assembler's detailed instructions. Where a question exists, consult the specifying engineer and/or equipment assembler.

## ! WARNING

**PERSONAL INJURY CAN OCCUR WHEN WORKING ON POWER SYSTEMS. ALWAYS TURN OFF POWER SUPPLYING BREAKER BEFORE CONDUCTING TESTS. TEST OUT OF THE CELL, IF POSSIBLE. THERE IS A HAZARD OF ELECTRICAL SHOCK OR BURN WHENEVER WORKING IN OR AROUND ELECTRICAL EQUIPMENT.**

Verify the grounding points of the system using high-voltage testers and resistance bridges to ensure that ground paths do not exist that could bypass the sensors.

Use a low-voltage (0 to 24 volt), high-current, ac source to apply a test current of 125 percent of the Digitrip unit pick-up setting through one phase of the circuit breaker. This should cause the breaker to trip in less than 1 second and operate the alarm indicator, if one is supplied. Reset the breaker and the alarm indicator. Repeat the test on the other two phases (see Figure 5.1).

Apply the same current as described above through one phase of the breaker, returning through the neutral sensor. The breaker should not trip, and the alarm indicator, if one is supplied, should not operate. Repeat the test on the other two phases.

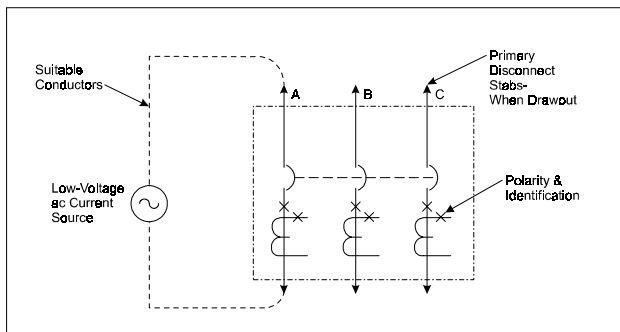

*Figure 5.1 Connection Details for Conducting Single Pole, Single Phase Current Tests with the Breaker Removed from the Cell*

Apply the same current as described above through any two phases of the breaker. The breaker should not trip, and the alarm indicator, if one is supplied, should not operate. Repeat the test using the other two combinations of breaker phases (see Figure 5.2).

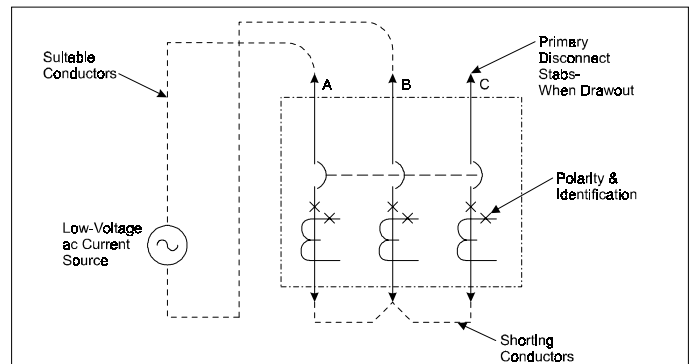

*Figure 5.2 Connection Details for Conducting Single Phase Current Tests with the Breaker Removed from the Cell*

## ! CAUTION

**RESTORE ALL TEMPORARY CONNECTIONS MADE FOR THE PURPOSE OF CONDUCTING TESTS TO PROPER OPERATING CONDITIONS BEFORE RETURNING THE BREAKER TO SERVICE.**

Record the test results on the test form provided with the equipment (Figure 8.3).

## 6.0 BATTERY

### 6.1 General

The battery plays no part in the protection function of the trip unit.

As indicated in Figure 3.1, the battery is provided to maintain the red LED indication of the Cause of Trip in the Digitrip 520 family of trip units. The battery is located under the rating plug door. A battery check pushbutton and a green Battery Check LED are also provided in the 520 family of trip units.

### 6.2 Battery Check

The battery is a long-life, lithium, camera-type unit. Check the status of the battery at any time by pressing the Battery Check pushbutton and observing the green LED. If the Battery Check LED does not light green, replace the battery. The condition of the battery has no effect on the protection function of the trip unit. Even with the battery removed, the unit will still trip the breaker in accordance with its settings. However, without the battery, the Cause of Trip LED will not be lighted red. If the battery is replaced, one or more of the Cause of Trip LEDs may be illuminated. Push the red Reset/Battery Test button to turn off the indicators; the trip unit will be ready to indicate the next cause of trip.

### 6.3 Battery Installation and Removal

The 3-volt lithium cell battery (see Figure 6.1) is easily removed and replaced. The battery is located in the cavity adjacent to the rating plug mounting screw, but is not part of the rating plug. Insert a small screwdriver at the left side of the rating plug, and to the left of the word OPEN, to open the rating plug door. Remove the old battery by pulling up on the removal tab that wraps under the battery cell. When inserting the new cell, pay special attention to ensure that the proper polarity is observed. The main body of the battery is the positive (+) side.

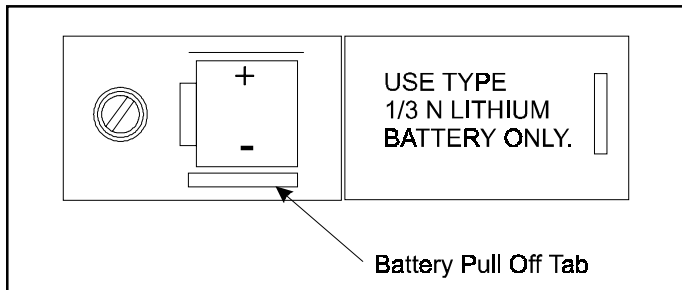

Figure 6.1 Digitrip Battery

**NOTE:** The battery can be replaced at any time, even while the circuit breaker is in-service, without affecting the operation of the circuit breaker or its protection functions.

### CAUTION

**EXERCISE CARE WHEN REPLACING THE BATTERY TO ENSURE THAT THE CORRECT POLARITIES ARE OBSERVED. POLARITY MARKINGS ARE SHOWN ON THE RATING PLUG WHEN THE HINGED COVER IS OPEN. ACCIDENTALLY INSTALLING THE BATTERY IN THE REVERSE DIRECTION WILL NOT HARM EITHER THE TRIP UNIT OR THE BATTERY, BUT WILL DEFEAT THE FUNCTION OF THE BATTERY.**

The replacement battery should be the same type as that already in the trip unit or an equivalent. Acceptable 3.0 volt lithium batteries may be obtained from the following companies:

**Company**  
 VARTA Batteries, Inc.  
 300 Elmsford Boulevard  
 Elmsford, N.Y. 10523  
 914-592-2500  
 (www.varta.com)

**Model**  
 CR 1/3N

Duracell, Inc.  
 Berkshire Corporate Park  
 Bethel, CT 06801  
 1-800-551-2355  
 (www.duracell.com)

DL 1/3N

Sanyo Energy Corporation  
 2055 Sanyo Avenue  
 San Ysidro, CA 92173  
 619-661-6620  
 (www.sanyo.co.jp)

CR 1/3N

### 7.0 FRAME RATINGS (SENSOR RATINGS AND RATING PLUGS)

The frame rating of a circuit breaker is the maximum RMS current it can continuously carry. The maximum short-circuit current rating of the circuit breaker is usually related to the frame rating as well.

A current value, ( $I_n$ ), that is less than the full frame rating may be chosen to be the basis for the coordination of the protection function of the breaker without affecting its short-circuit current capability. For the DT20 family of trip units, this is implemented by changing the current sensors and the corresponding rating plug. These sensors and rating plugs are available in kit form.

The current sensor rating is the maximum current the circuit breaker can carry with the specified current sensors installed. The sensor rating can be the same or less than the frame rating, but not greater.

This value, ( $I_n$ ), is the basis for the trip unit current settings:

1. The Instantaneous and Ground Current Settings (if provided) are multiples of ( $I_n$ ) (see Sections 4.6 and 4.7).
2. The Long Delay Current Setting, ( $I_r$ ), is a fractional multiple of ( $I_n$ ): Long Delay Current Setting = ( $I_r$ ) = LD x ( $I_n$ ) (see Section 4.2).
3. The Short Delay Current Setting is a multiple of ( $I_r$ ): Short Delay Current Setting = SD x ( $I_r$ ) = SD x [LD x ( $I_n$ )] (see Section 4.4).

**CAUTION**

**BEFORE YOU FIT THE RATING PLUG INTO THE TRIP UNIT, BE SURE TO CHECK THAT THE SENSOR RATING MATCHES THAT PRINTED ON THE RATING PLUG DOOR. INSTALLING A RATING PLUG THAT DOES NOT MATCH THE SENSOR RATING CAN PRODUCE SERIOUS MISCOORDINATION AND/OR FAILURE OF THE PROTECTION SYSTEM.**

**NOTE:** Rating plugs from Digitrip models 210, 500, or 510 **CANNOT** be used with DT20 Trip Units.

**8.0 RECORD KEEPING**

Use the forms shown in Figures 8.1 and 8.2 for record keeping. Fill in these forms, giving the indicated reference information and initial time-current trip function settings. If desired, make a copy of the form and attach it to the interior of the breaker cell door or another visible location. Figure 8.3 provides a place for recording test data and actual trip values.

Ideally, sheets of this type should be used and maintained by those personnel in the user's organization that have the responsibility for protection equipment.

**9.0 REFERENCES****9.1 Magnum and Magnum DS Circuit Breakers**

I.B. 2C12060	Magnum DS Breaker Instructions
I.B. 2C13060	Magnum I. Breaker Instructions
4A36346	Zone Interlocking Application with Non-Magnum Breakers

**9.2 Time-Current Curves**

The Time-Current Curves are listed below for particular trip unit models. All protection function time-current settings should be made following the recommendations of the specifying engineer in charge of the installation.

70C1009	Digitrip 220 (LI) Curve
70C1006	Digitrip 520 (LS) Curve
70C1007	Digitrip 520 (I) Curve
70C1008	Digitrip 520 (G) Curve

<b>DIGITRIP</b>				
TRIP FUNCTION SETTINGS				
Circuit No./Address _____		Breaker Shop Order Reference _____		
PER UNIT MULTIPLIERS				
Rating Plug Amperes ( <i>I<sub>n</sub></i> ) _____		<i>I<sub>r</sub></i> Continuous Ampere Rating = LDS x <i>I<sub>n</sub></i> _____		
Trip Function	Per Unit Setting	Multi	Ampere Equivalent Setting	Time Delay
Inst.		<i>I<sub>n</sub></i>		<del> </del>
Long Delay		<i>I<sub>n</sub></i>		Sec.
Short Delay		<i>I<sub>r</sub></i>		Sec.
Ground Fault		<i>I<sub>n</sub></i>		Sec.
Date _____		By _____		

Figure 8.1 Typical Trip Function Record Nameplate

<b>DIGITRIP</b>				
<b>AUTOMATIC TRIP OPERATION RECORD</b>				
<b>Circuit No./Address</b>	<b>Breaker Shop Order Reference</b>			
<b>Trip Function</b>	<b>Settings Reference</b>			
	<b>Orig. 0</b>	<b>Rev. 1</b>	<b>Rev. 2</b>	<b>Rev. 3</b>
Instantaneous				
Long Delay Setting				
Long Delay Time				
Short Setting				
Short Time				
Ground Fault Setting				
Ground Fault Time				
<b>Date of Trip</b>	<b>Trip Mode Indicator</b>	<b>Setting Ref.</b>	<b>Setting Change Made</b>	<b>Investigated By</b>

Figure 8.2 Automatic Trip Operation Record

<b>GROUND FAULT TEST RECORD FORM</b>			
Ground Fault Test Record should be retained by those in charge of the building's electrical installation in order to be available to the authority having jurisdiction.			
<b>Test Date</b>	<b>Circuit Breaker Number</b>	<b>Results</b>	<b>Tested by</b>

Figure 8.3 Typical Performance Test Record Form

---

**NOTICE**

---

**THE PROVISION FOR ZONE INTERLOCKING IS STANDARD ON MAGNUM CIRCUIT BREAKERS WITH DIGITRIP 520 FAMILY TRIP UNITS FOR SHORT TIME AND GROUND FAULT FUNCTIONS. THE APPROPRIATE JUMPER TO TERMINAL B8 AND B9 MUST BE ADDED ON THE BREAKER IF ZONE INTERLOCKING IS NOT DESIRED OR IF FIELD TESTING IS DESIRED.**

**APPENDIX A Zone Interlocking Examples****CASE 1: There is no Zone Selective Interlocking.  
(Standard time delay coordination is used.)**

Assume that a ground fault of 2000 Amperes occurs and refer to Figure A.1.

*Fault at location 3*

The branch breaker will trip, clearing the fault in 0.1 seconds.

*Fault at location 2*

The feeder breaker will trip, clearing the fault in 0.3 seconds.

*Fault at location 1*

The main breaker will trip, clearing the fault in 0.5 seconds.

**CASE 2: There is Zone Selective Interlocking.**

Assume a ground fault of 2000 Amperes occurs and refer to Figure A.1.

*Fault at location 3*

The branch breaker trip unit will initiate the trip in 0.045 seconds to clear the fault and the branch will send a restraint signal to the feeder trip unit; the feeder will send a restraint interlocking signal to Z1.

Main and feeder trip units will begin to time out and, in the event that the branch breaker does not clear the fault, the feeder breaker will clear the fault in 0.3 seconds (as above). Similarly, in the event that the feeder breaker does not clear the fault, the main breaker will clear the fault in 0.5 seconds (as above).

*Fault at location 2*

The feeder breaker trip unit will initiate the trip in 0.045 seconds to clear the fault and will send an interlocking signal to the main trip unit. The main trip unit will begin to time out and, in the event that the feeder breaker Z2 does not clear the fault, the main breaker will clear the fault in 0.5 seconds (as above).

*Fault at location 1*

There are no interlocking signals. The main breaker trip unit will initiate the trip in 0.045 seconds.

Figure A.2 presents a Zone Selective Interlocking connection diagram for a system with two main breakers from incoming sources and a bus tie breaker. Note that the blocking diode D1 is needed so that the feeder breakers can send interlocking signals to both the main and the tie breakers and prevent the tie breaker from sending an interlocking signal to itself.

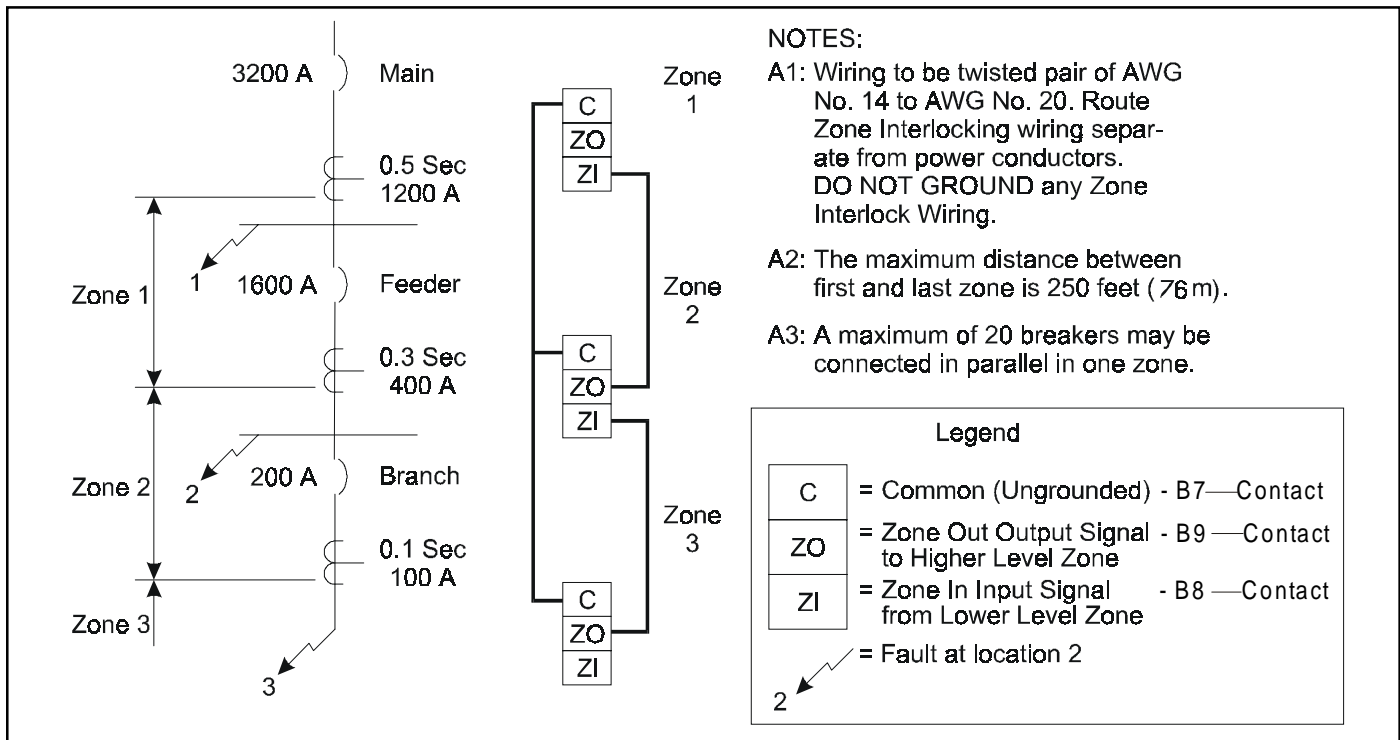

Figure A.1 Typical Zone Interlocking

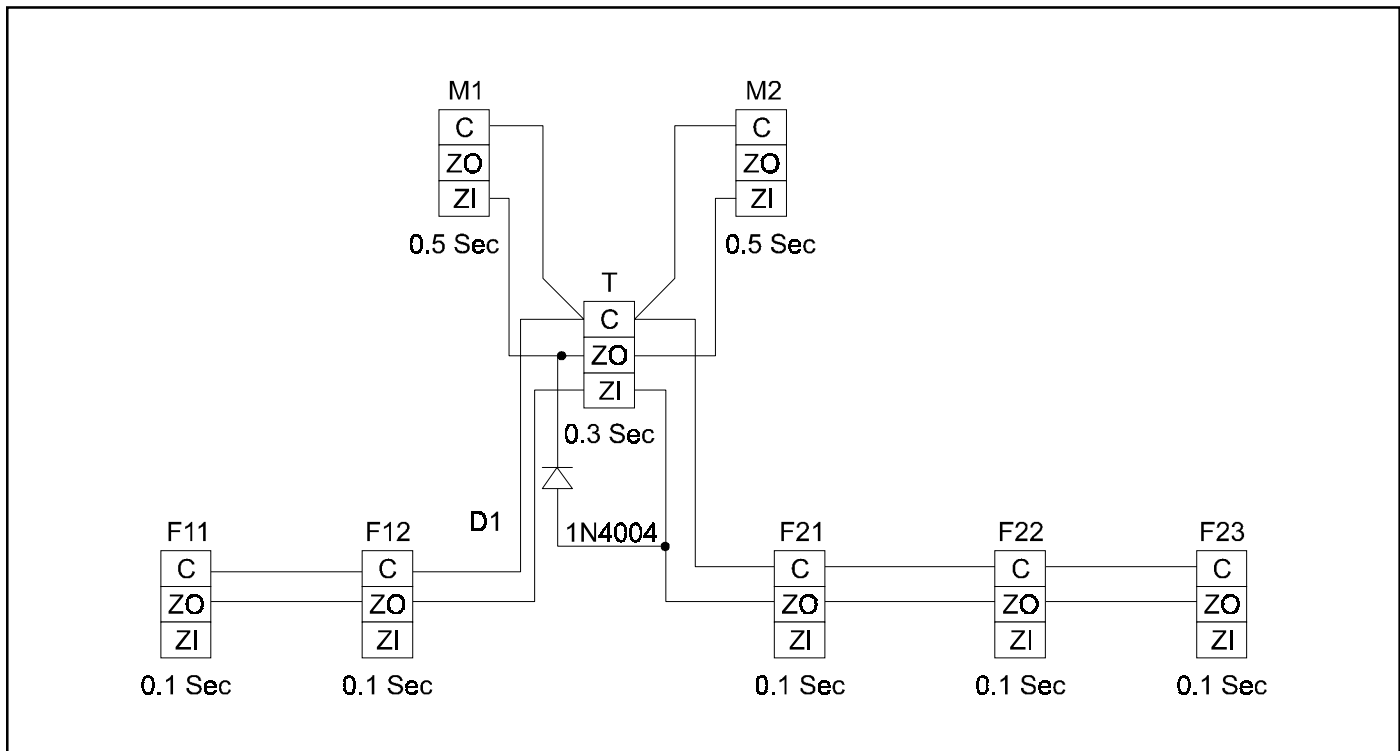

Figure A.2 Typical Zone Interlocking Connections with Two Main Breakers (M1, M2) and a Tie Breaker (T)

## Appendix B Troubleshooting Guide

Symptom	Probable Cause	Possible Solution(s)	References
Unit status LED is not blinking.	Current thru breaker is <25% of sensor rating.	No problem. Status LED will not operate with breaker currents <25% of sensor rating.	
	Trip unit is malfunctioning.	Replace trip unit.	
Unit status LED is steady on.	Light loading.	No problem. Status LED will not flash until 25% of sensor rating.	See Section 3.2 Note.
	Trip unit is malfunctioning.	Replace trip unit.	
As soon as current starts to flow through the breaker, it trips and the Instantaneous trip LED comes on.	Rating plug is not installed or is loose.	Install rating plug and/or check for loose connections.	
	Rating plug is open internally.	Replace rating plug.	
	Trip unit is malfunctioning.	Replace trip unit.	
LED does not come on when battery check button is pressed.	Battery installed backwards.	Install correctly.	
	Dead battery.	Replace battery.	
	Trip unit is malfunctioning.	Replace trip unit.	
Breaker trips on ground fault.	There actually is a ground fault.	Find location of the fault.	
	On 4-wire residual systems, the neutral current sensor may not have the correct ratio or be properly connected.	Check connections at terminals B4 and B5. Check that the neutral current sensor ratio matches the breaker. Check that the connections from the neutral current sensor to the breaker are not reversed. Check B6, B7 for correct programming of jumper.	See Section 2.3, Notes.
	Trip unit is malfunctioning.	Replace trip unit.	
Breaker trips too rapidly on ground fault or short delay (Zone Selective Interlocking not used).	Connection from Zout to Zin is missing.	Make connections B8 to B9.	Refer to Appendix A.
	Trip unit settings are not correct.	Change settings.	
	Trip unit is malfunctioning.	Replace trip unit.	
Breaker trips too rapidly on long delay.	Long Time Memory selected.	Turn off Long Time Memory.	Refer to Section 4.3.
	Trip unit settings are not correct.	Change settings. Long Time Delay setting is based on $6 \times I_r$ .	
LCD display is not energized.	Light load.	Check breaker ordering information.	Refer to Section 1.6.1.
	No auxiliary power input.	Check voltage input terminals A14-A15.	Refer to Section 1.6.1.



Appendix C Typical Breaker Master Connection Diagram

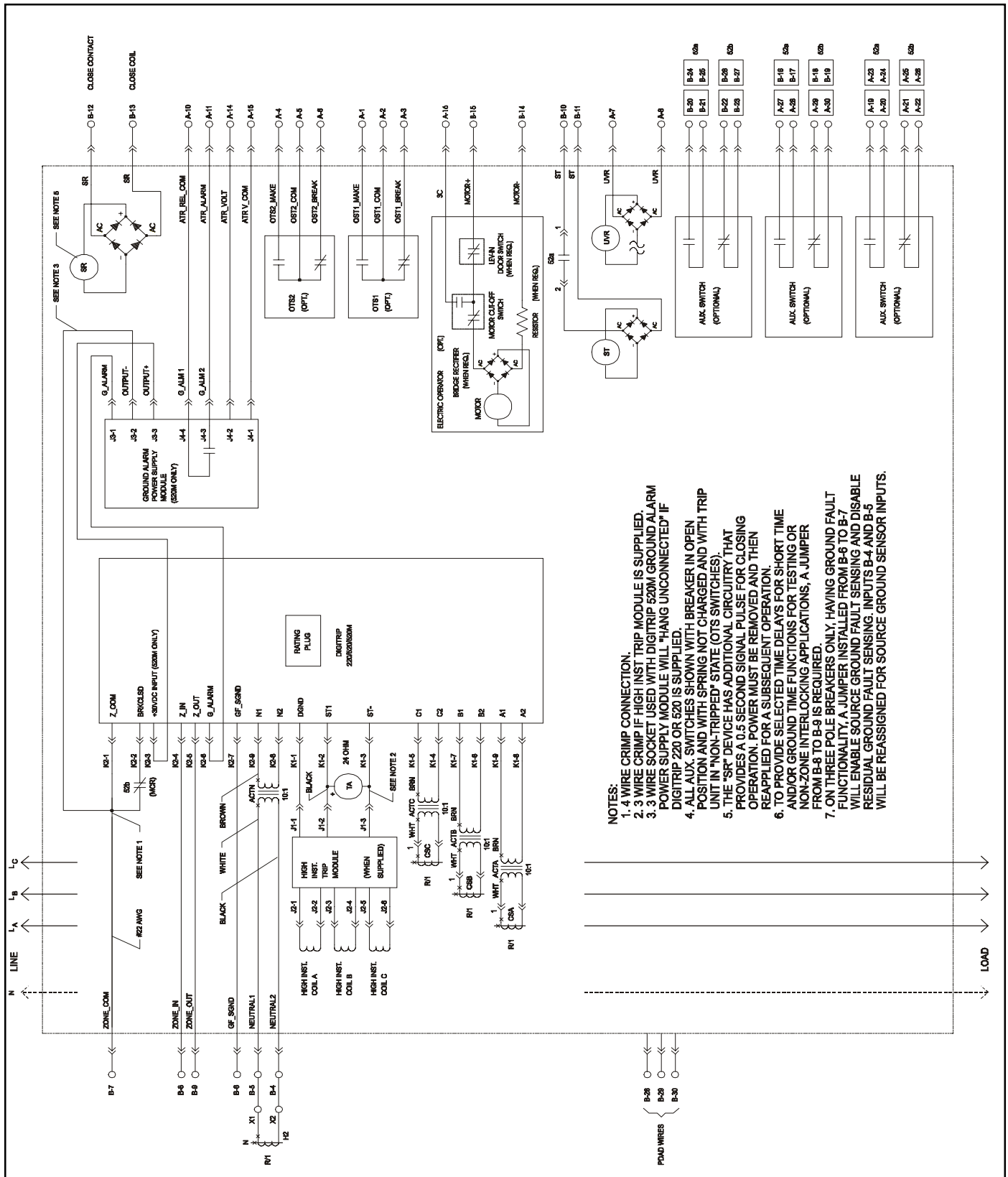

This instruction booklet is published solely for information purposes and should not be considered all inclusive. If further information is required, consult Cutler-Hammer, Inc.

The sale of the product shown in this literature is subject to the terms and conditions outlined in appropriate Cutler-Hammer, Inc., selling policies or other contractual agreements between the parties. This literature is not intended to and does not enlarge or add to any such contract. The sole source governing the rights and remedies of any purchaser of this equipment is the contract between the purchaser and Cutler-Hammer, Inc.

NO WARRANTIES, EXPRESSED OR IMPLIED, INCLUDING WARRANTIES OF FITNESS FOR A PARTICULAR PURPOSE OR MERCHANTABILITY, OR WARRANTIES ARISING FROM THE COURSE OF DEALING OR USAGE OF TRADE, ARE MADE REGARDING THE INFORMATION, RECOMMENDATIONS, AND DESCRIPTIONS CONTAINED HEREIN.

In no event will Cutler-Hammer, Inc., be responsible to the purchaser or user in contract, in tort (including negligence), strict liability, or otherwise for any special, indirect, incidental, or consequential damage or loss whatsoever, including, but not limited to, damage or loss of the use of equipment, plant or power system, cost of capital, loss of power, additional expenses in the use of existing power facilities, or claims against the purchaser or user by its customers resulting from the use of the information, recommendations, and descriptions contained herein.



**Cutler-Hammer**

Pittsburgh, PA U.S.A.

Effective 8/13/99  
Printed in U.S.A.

