

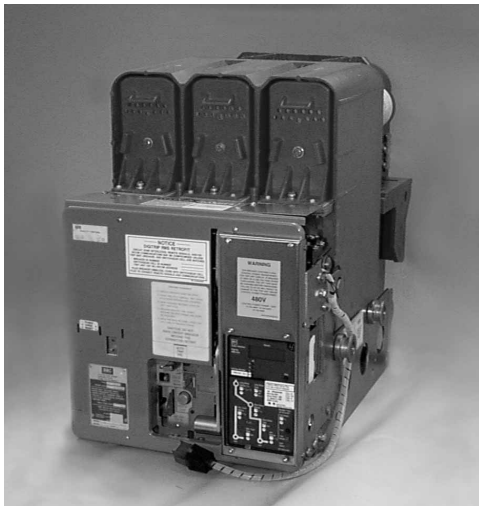

## Digitrip Retrofit System for BBC LKD 8 Breakers



### SAFETY PRECAUTIONS



#### WARNING

**POWER CIRCUIT BREAKERS ARE EQUIPPED WITH HIGH SPEED, HIGH ENERGY OPERATING MECHANISMS. THE BREAKERS AND THEIR ENCLOSURES ARE DESIGNED WITH SEVERAL BUILT-IN INTERLOCKS AND SAFETY FEATURES INTENDED TO PROVIDE SAFE AND PROPER OPERATING SEQUENCES. TO PROVIDE MAXIMUM PROTECTION FOR PERSONNEL ASSOCIATED WITH THE INSTALLATION, OPERATION, AND MAINTENANCE OF THESE BREAKERS, THE FOLLOWING PRACTICES MUST BE FOLLOWED. FAILURE TO FOLLOW THESE PRACTICES MAY RESULT IN DEATH, PERSONAL INJURY, OR PROPERTY DAMAGE.**

- Only qualified persons, as defined in the National Electric Code, who are familiar with the installation and maintenance of power circuit breakers and their associated switchgear assemblies should perform any work associated with these breakers.

- Completely read and understand all instructions before attempting any installation, operation, maintenance, or modification of these breakers.
- **Always turn off and lock out the power source feeding the breaker prior to attempting any installation, maintenance, or modification of the breaker. Do not use the circuit breaker as the sole means for isolating a high voltage circuit. Follow all lockout and tagging rules of the National Electric Code and all other applicable codes, regulations, and work rules.**
- Do not work on a closed breaker or a breaker with the closing springs charged. Trip (open) the breaker and be sure the stored energy springs are discharged before performing any work. The breaker may trip open or the charging springs may discharge, causing crushing or cutting injuries.
- For drawout breakers, trip (open), and then remove the breaker to a well-lit work area before beginning work.
- Do not perform any maintenance: including breaker charging, closing, tripping, or any other function which could cause significant movement of the breaker while it is on the extension rails. Doing so may cause the breaker to slip from the rails and fall, potentially causing severe personal injury to those in the vicinity.
- **Do not leave the breaker in an intermediate position in the switchgear cell. Always leave it in the connected, disconnected or (optional) test position. Failure to do so could lead to improper positioning of the breaker and flashover, causing death, serious personal injury, and / or property damage.**
- **Do not defeat any safety interlock. Such interlocks are intended to protect personnel and equipment from damage due to flashover and exposed contacts. Defeating an interlock could lead to death, severe personal injury, and / or property damage.**

Cutler-Hammer Digitrip Retrofit Kits are available in a number of configurations that provide a wide range of features. The Digitrip System starts with the 510 Basic Kit which offers true RMS sensing, overcurrent protection, and self-testing features. Advanced Digitrip Retrofit Kits feature zone interlocking, digital alphanumeric displays, remote alarm signals, PowerNet communications, energy monitoring capabilities, power factors, and harmonic content measurements.

The following table provides a quick reference of the components supplied with each level of Retrofit Kit. Before beginning the Retrofit process, take a minute to review the information contained in the table. It is important that the Retrofitter understands which level of Retrofit Kit is to be installed and which components are included with the Kit.

The instructions contained in this manual cover the installation of all levels of the Retrofit Kit. If the Kit you are installing does not contain a certain component, skip the instructions for that component and proceed to the next.

Throughout the Retrofit process, refer to the Torque Tables at the back of this manual for specific torque values.

If you have any questions concerning the Retrofit Kit and / or the Retrofit process, contact Cutler-Hammer at 1-800-937-5487.

| Components                                      | 510 Basic | 510 with Zone Interlock | 610                 | 810                 | 910                 |
|---|-----------|-------------------------|---------------------|---------------------|---------------------|
| Trip Unit                                       |           |                         |                     |                     |                     |
| Rating Plug                                     |           |                         |                     |                     |                     |
| Auxiliary Current Transformer (CT) Module       |           |                         |                     |                     |                     |
| Auxiliary CT Harness                            |           |                         |                     |                     |                     |
| Sensors   |           |                         |                     |                     |                     |
| Sensor Harness                                  |           |                         |                     |                     |                     |
| Direct Trip Actuator (DTA)                      |           |                         |                     |                     |                     |
| Mounting Brackets and Hardware                  |           |                         |                     |                     |                     |
| External Harness                                | Plug      | 1 Connector Harness     | 2 Connector Harness | 4 Connector Harness | 4 Connector Harness |
| Cell Harness                                    |           |                         |                     |                     |                     |
| Breaker Mounted Control Power Transformer (CPT) |           |                         |                     |                     |                     |
| Potential Transformer (PT) Module               |           |                         |                     |                     |                     |
| Auxiliary Switch                                |           |                         |                     |                     |                     |

### Step 1: General Breaker Preparation

Before attempting to remove the Breaker from the Cell, or perform any Retrofit Operation, be sure to read and understand the Safety Precautions section of this manual. In addition, be sure to read and understand the *Instructions for the Application of Digitrip RMS Retrofit Kits on Power Circuit Breakers* (Retrofit Application Data - Publication AD-33-855-2), supplied with the Digitrip Retrofit Kit.



### WARNING

**DO NOT ATTEMPT TO INSTALL OR PERFORM MAINTENANCE ON EQUIPMENT WHILE IT IS ENERGIZED. SEVERE PERSONAL INJURY OR DEATH CAN RESULT FROM CONTACT WITH ENERGIZED EQUIPMENT. VERIFY THAT NO VOLTAGE IS PRESENT BEFORE PROCEEDING.**

- A. Trip the Breaker and remove it from the Cell.  
Move the Breaker to a clean, well-lit work area.

**NOTE:** It is the responsibility of the Retrofitter to insure that the Breaker and all original components are in good condition. Visually inspect all Breaker components for signs of damage or wear. If any signs of damage or wear are detected for components *not included* in the Retrofit kit, secure the necessary replacement parts *before* beginning the Retrofit process.

The force necessary to trip the Breaker should not exceed three (3) lbs.

**NOTE:** It is the responsibility of the Retrofitter to insure that the proper, manufacturer's recommended crimping tools and terminals are used for each type of connector. It is also the responsibility of the Retrofitter to insure that all wire preparations, connections, strippings, terminations, and wiring techniques are performed according to the latest IEEE, NEC, and / or NEMA industry standards, specifications, codes, and guidelines.

To begin the Retrofit process, refer to the components list at the end of this manual. Lay-out the components and hardware according to the steps outlined. The parts bags are labeled with the corresponding step number. The components and hardware will be used to complete each step in the Retrofit process.

**NOTE:** The Breaker used for the photographs contained in this manual was a Fused version of the BBC LKD 8 Breaker. Therefore, if Retrofitting a Non-fused version of the Breaker, some photographs may not exactly match the Breaker being Retrofitted.

### Step 2: Removing the Original Trip System and Preparing the Breaker for Retrofitting



Refer to the BBC LKD 8 Instruction Manual, originally supplied with the Breaker, to perform the following procedures.

- Remove and save the Breaker Front Plate and all mounting hardware.
- Remove and save the Breaker Top Plate and all mounting hardware.
- Remove and save the Breaker Top Plate Mounting Bracket and all mounting hardware.
- Remove and save the Arc Chutes and all mounting hardware.

- E. Remove and save the Arc Chute Retaining Bar and all mounting hardware.
- F. Remove and scrap the original Solid State Trip Unit and all associated mounting hardware.
- G. Remove and scrap the original Direct Trip Actuator and all associated mounting hardware and wiring.
- J. Remove and save the Fuses and all mounting hardware.
- K. Remove and save the screws that secure the Blown Fuse Indicator Wires to the outer, upright Copper Connectors.
- L. Remove the hardware that secures the Bottom Finger Clusters to the bottom Breaker Stabs. Remove and save the Bottom Finger Clusters and all mounting hardware.

*For Fused Breakers Only.*

- H. Remove and save the top Fuse Insulation Piece and all mounting hardware.

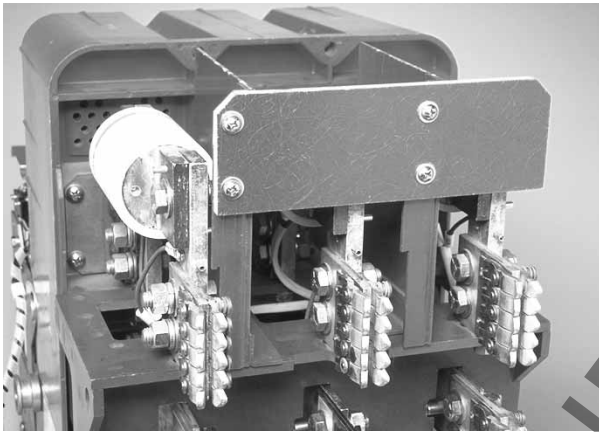

- I. Remove and save the Insulation Barriers located between the Phase 1 & 2 and Phase 2 & 3 Fuses and all mounting hardware. Note that the two rear mounting bolts also secure the wire clamps that hold the Blown Fuse Indicator Wiring Harness in place.

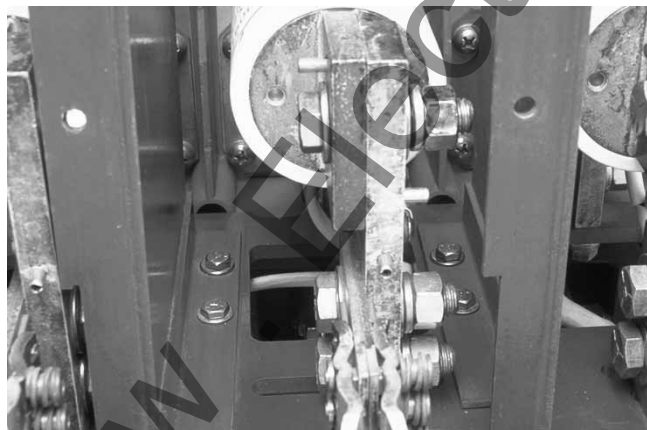

- M. Working from the bottom of the Fuse Cradle, remove and save the three bolts that secure the Fuse Cradle to the Top Breaker Stabs. Remove and save the Fuse Cradle and all mounting hardware.

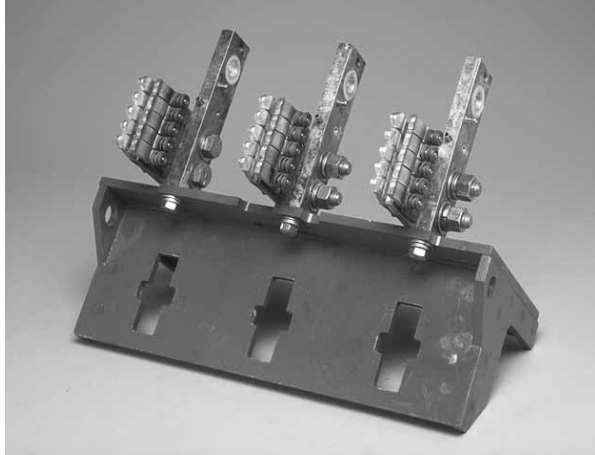

*For Non-Fused Breakers Only.*

- N. Remove the hardware that secures the bottom Finger Clusters to the bottom Breaker Stabs. Remove and save the bottom Finger Clusters and all mounting hardware.

*For All Breakers.*

- O. Remove and scrap the original Sensors, Sensor Harness, and mounting hardware. Save the Sensor Retaining Plate and the original spacers for use later in the Retrofit Process.

**Step 3: Installing the Sensors**

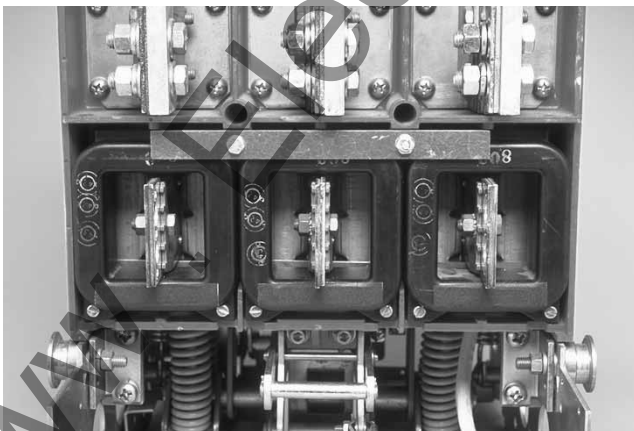

- A. Slide a Sensor over each bottom Breaker Stab, as shown. Note that the Sensors must be installed with the label facing away from the Breaker and the Terminals on the bottom.

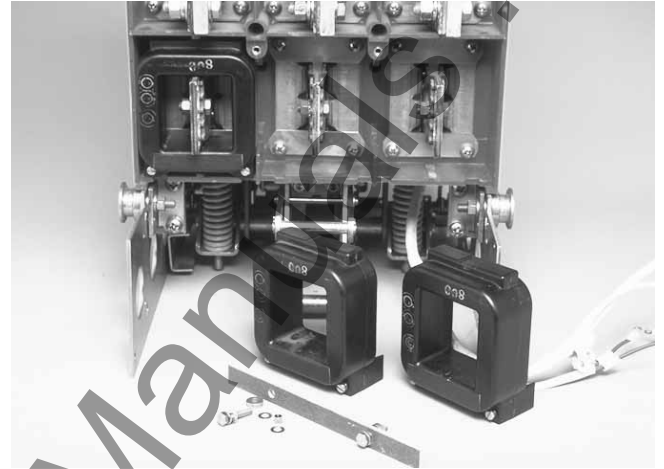

- B. Secure the Sensors to the Breaker using the original Sensor Retaining Plate; the (2) original spacers; the (2) new spacers; and the (2) .250-20 x 1.00" bolts, (2) lock washers, and (6) flat washers supplied. To insure that the Sensors are correctly secured to the Breaker, the original spacers and new mounting hardware and spacers must be used in the following order. Install a lock washer then flat washer onto the bolt. Insert the bolt through the Sensor Retaining Plate. Then install a flat washer, new spacer, flat washer, then the original spacer onto the bolt as shown.

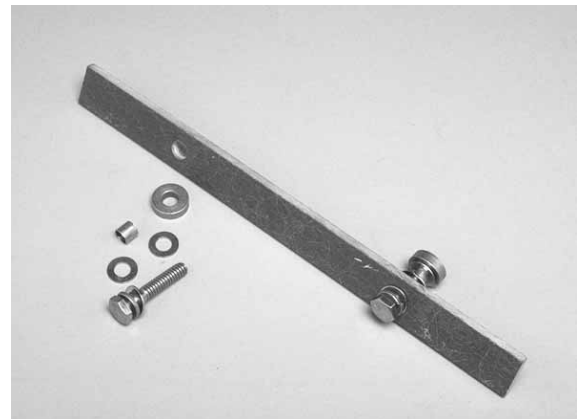

#### Step 4: Preparing and Installing the Auxiliary CT Harness and DTA Wires

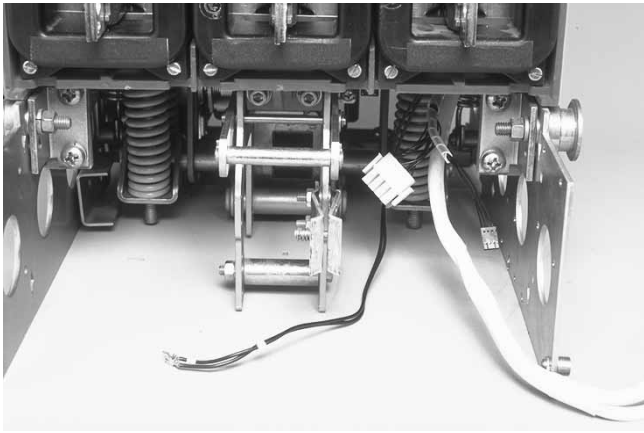

- A. Straighten the Aux. CT Harness in preparation to install the supplied spiral wire wrap.

*For Kits Supplied with a PT Module Only:*  
Straighten and lay the PT Extension Harness next to the Aux. CT Harness. Note that the male plug on the PT Extension Harness must correspond with the white, 9-position connector on the Aux. CT Harness.

- B. Install the supplied spiral wire wrap on the Aux. CT Harness and, if applicable, the PT Extension Harness as shown.

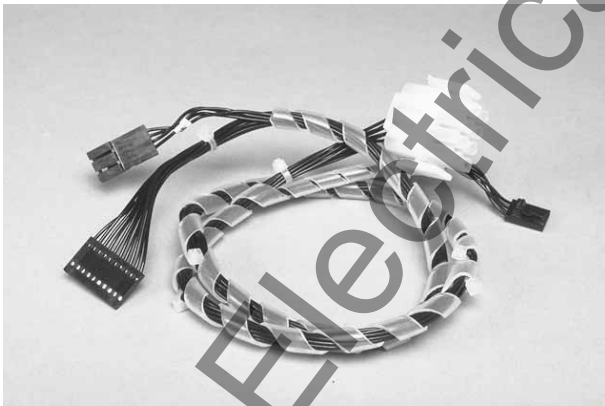

- C. Working from the left rear corner of the Breaker, feed the Aux. CT Harness up through the Breaker, as shown, to the front, top left corner of the Breaker.

**NOTE:** If the Breaker being Retrofitted is Fused, the Aux. CT Harness will follow the same route as the Blown Fuse Indicator Wiring Harness.



- D. Working from the front, left top corner of the Breaker, route the DTA Extension Harness down through the Breaker, following the same path as the Aux. CT Harness.

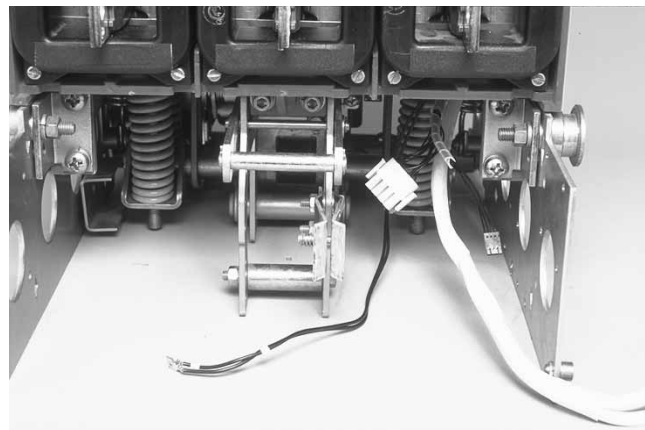

E. *For Kits Supplied with a Breaker Mounted CPT Only:* Again working from the front, left top corner of the Breaker, route the CPT Harness down through the Breaker following the same path as the DTA Extension Harness and Aux. CT Harness.

**Step 5: Installing the Aux. CT Module**

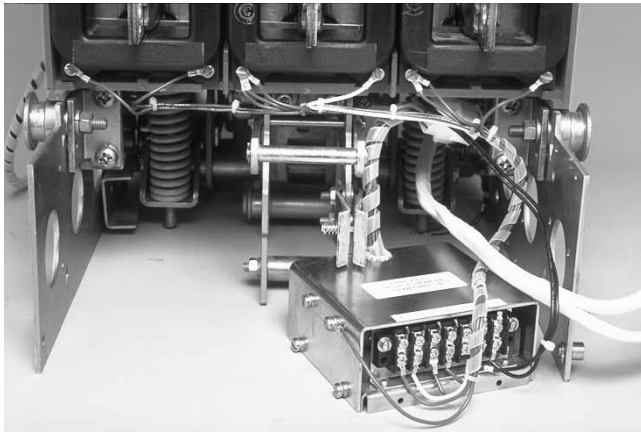

A. Using Drilling Plan "A", drill three (3) .219" holes in the left Breaker Frame. These will be used later in the Retrofit Process to mount the Aux. CT Module.

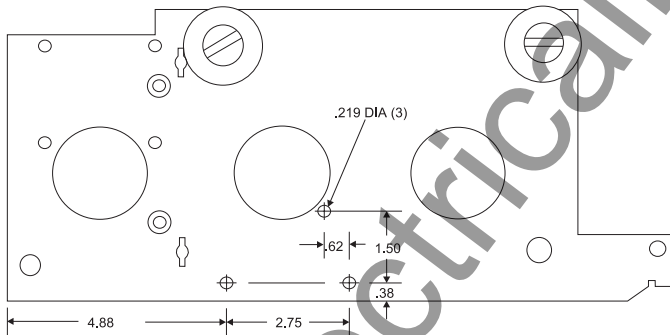

**Drilling Plan "A"**

*For Kits Supplied with a Breaker Mounted CPT Only:* Using Drilling Plan "B", drill four (4) .219" holes in the left Breaker Frame. These will be used later in the Retrofit Process to mount the Breaker Mounted CPT.

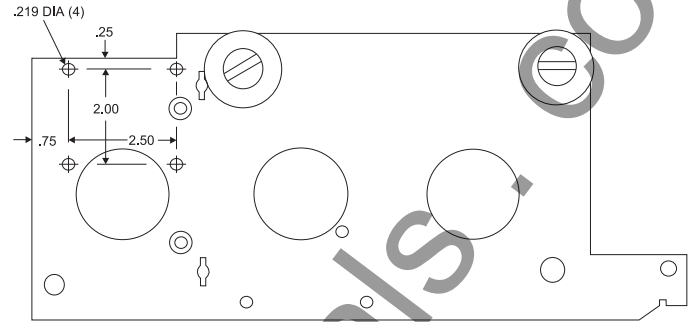

**Drilling Plan "B"**

*For Kits Supplied with a PT Module Only.*

- B. Remove and save the Warning Label Mounting Bracket from the PT Module.
- C. Align the Glass Poly Insulation Barrier and the PT Module with the holes in the PT Module Mounting Bracket as shown. Secure the PT Module and Insulation Plate to the mounting bracket using the (2) .138-32 x .500" screws, (4) flat washers, (2) lock washers, and (2) nuts supplied.
- D. Align the Warning Label Mounting Bracket, removed in Step 5-B, with the holes in the PT Module Mounting Bracket as shown. Secure the PT Module Warning Label Bracket to the mounting bracket using the (2) .112-40 x .250" screws, (2) lock washers, and (2) flat washers supplied.

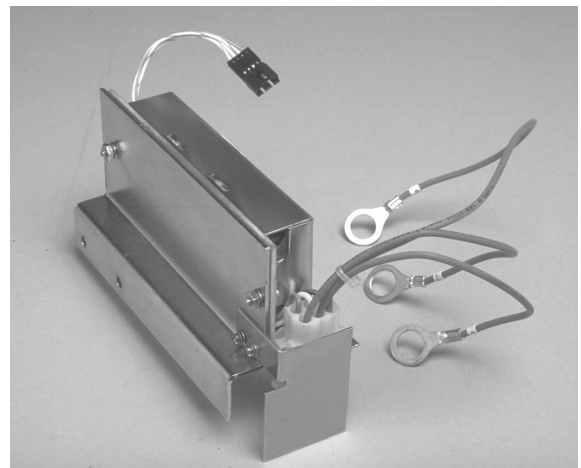

- E. Align the PT Module Assembly, as shown, with the holes in the top, left side of the Aux. CT Module. Secure the PT Module Assembly to the Aux. CT Module using the (2) .190-16 x .500" thread cutting screws, (2) lock washers, and (2) flat washers supplied.
- F. Install the supplied PT Module Warning Label, as shown, over the existing label.



*For All Breakers.*

- G. Working from the back of the Breaker, set the Aux. CT Module near the left side of the Breaker. Connect the DTA Extension Harness to the terminals of the Aux. CT Module: positive (+) wire to the OP terminal and the unmarked wire to the ON terminal.
- H. Connect the Sensor Harness to the proper terminals on the Aux. CT Module. Refer to Section 12 of the Retrofit Application Data, supplied with the Retrofit Kit, for detailed wiring specifications.

Connect the green ground wire from the Sensor Harness (with the ring terminal) to the screw in the left side of the Aux. CT Module.

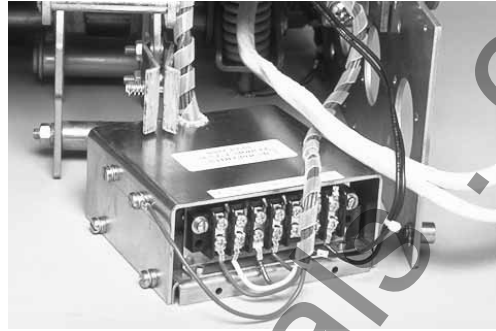

*For Kits Supplied with a PT Module Only:*  
Connect the green ground wire from the Sensor Harness (with the ring terminal) to the front screw securing the PT Module to the Aux. CT Module.

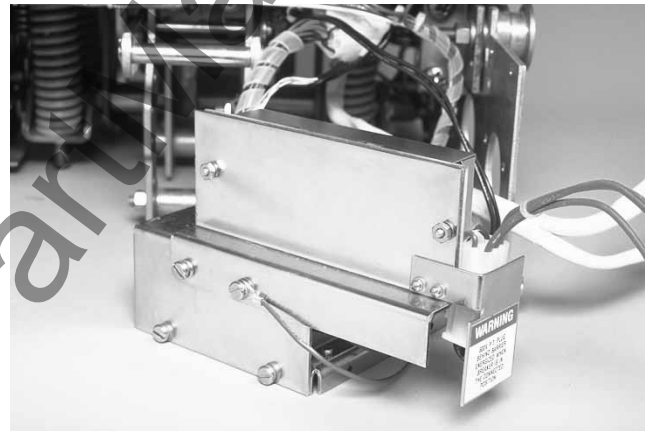

- I. Route the Sensor Harness to the Sensors. Connect the ring terminals of the Sensor Harness to the Sensors. Refer to Section 12 of the Retrofit Application Data, supplied with the Retrofit Kit, for detailed wiring specifications.

Depending on the Sensors supplied with the Retrofit Kit, the following conventions apply.

**Sensor Style No.**

|            |               |
|------------|---------------|
| 4A35845H01 | X1-X2 = 800 A |
| 4A35856H01 | X1-X2 = 600 A |
| 4A35857H01 | X1-X2 = 400 A |

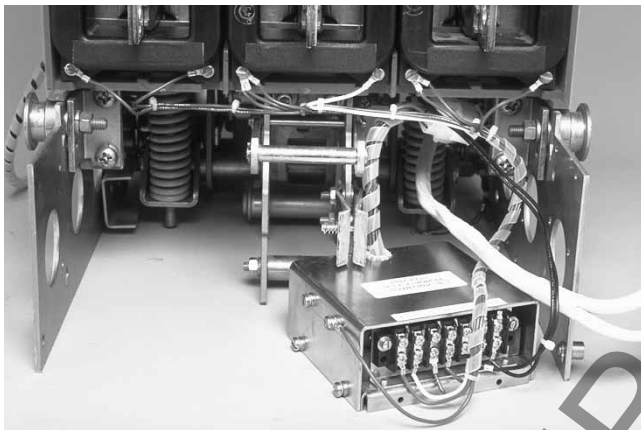

- J. Remove the existing screws from the right side of the Aux. CT Module.
- K. *For Kits Supplied with a PT Module Only:* Connect the PT Extension Harness to the PT Harness.



**NOTE: The PT Wires will be connected to the Breaker later in the Retrofit Process.**

- L. Connect the Aux. CT Harness to the Aux. CT Module.



- M. Align the Aux. CT Module Assembly with the three (3) holes drilled in the left Breaker Frame in Step 5-A. Secure the Aux. CT Module Assembly to the left Breaker Frame using the (3) .190-16 x .500" thread cutting screws, (3) lock washers, and (3) flat washers supplied.

For Kits Supplied with a Breaker Mounted CPT Only.

### Step 6: Installing the Breaker Mounted CPT



**NOTE:** The High Voltage (HV) Wires have a **LOAD Side** and a **LINE Side**. The HV Wires must be installed in the correct orientation during the following procedure. For the purpose of identification, the words "Load Side" are marked on the female fuse receptacle of each HV Wire.



**NOTE:** The Load Side HV Wires are longer than necessary and are cut during the following steps. Before cutting the wires, be sure that sufficient length is left so that the connections can be made to the correct terminals on the CPT.

- A. Temporarily position the black plug of the CPT Harness near the bottom, right side of the front of the Breaker.
- B. Temporarily align the holes in the Breaker Mounted CPT with the holes drilled in the left Breaker Frame in Step 5-A. Note that the X1 and X2 terminals face the top of the Breaker.
- C. Route the CPT Harness to the Breaker Mounted CPT. Mark and cut the CPT Harness to an appropriate length. Strip an appropriate length of insulation and attach a .138" ring terminal to each wire of the CPT Harness.
- D. Again, temporarily align the CPT with the holes in the left Breaker Frame. Position the fuses on the High Voltage (HV) Wires in an accessible location near the top of the CPT. Route the Load Side HV Wires to the "H" terminals on the CPT.
- E. Mark and cut the Load Side of each HV Wire to an appropriate length for connection to the CPT. Remove and place the CPT on the work surface near the left, rear corner of the Breaker.
- F. Strip an appropriate length of insulation from the Load Side HV Wires and attach a .138" ring terminal to each. Attach the HV Wires to the CPT terminals to achieve the required voltage (see the following table).

| Voltage Required | CPT Terminals Used |
|------------------|--------------------|
| 480 Volt Circuit | H1 & H4            |
| 240 Volt Circuit | H1 & H3            |
| 208 Volt Circuit | H1 & H2            |

**NOTE: The terminals to which the Load Side HV wires are connected determine the voltage of the CPT which, in turn, limits the voltage of the Breaker. Verify that the line voltage of the circuit matches the CPT voltage BEFORE putting the Breaker into service.**

**NOTE: To avoid the possibility of arcing, the ring terminals of the HV Wires must be situated so they are completely behind the Glass Poly Insulation (See Photo).**

- I. Temporarily place the HV Fuses in the Breaker above the mounting position of the Breaker Mounted CPT. Align the Breaker Mounted CPT Assembly with the holes in the left Breaker Frame. Secure the CPT to the left Breaker Frame using the (4) .190-32 x .625" screws, (8) flat washers, (4) lock washers, and (4) nuts supplied.

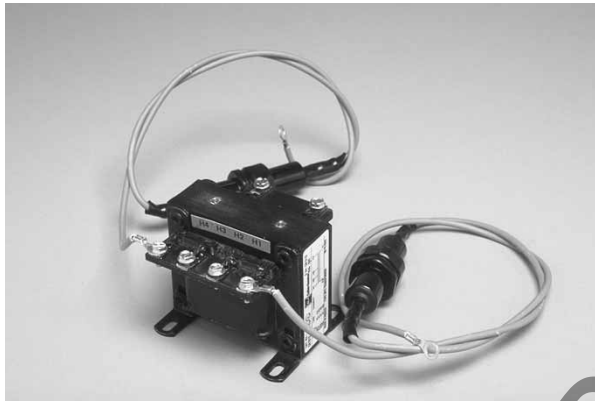

- G. Connect the CPT Harness ring terminals to the X1 and X2 terminals on the CPT.
- H. Attach the Glass Poly Insulation Plate to the top of the CPT, as shown, using the (2) .138-20 x .375" thread cutting screws, (2) lock washers, and (2) flat washers supplied.



**NOTE: The Line Side HV Wires will be connected to the Breaker later in the Retrofit Process.**

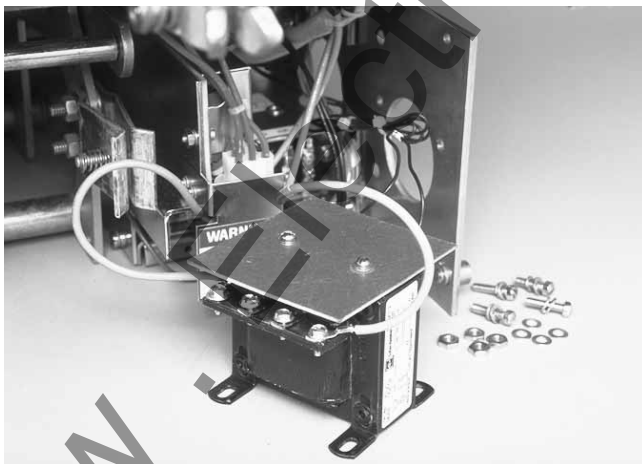

## Step 7: Reinstalling the Original Rear Breaker Components

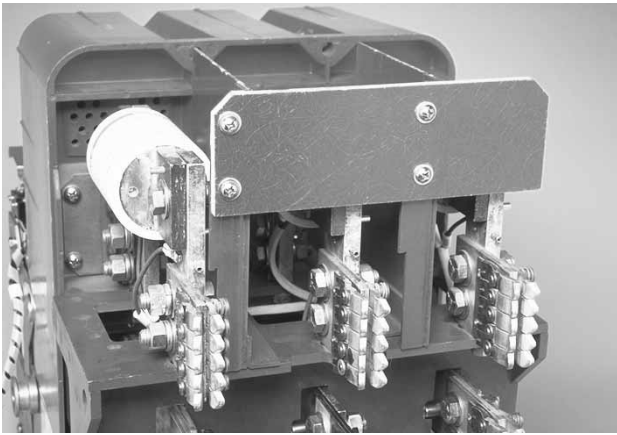

- A. *For Kits Supplied with a PT Module Only.* Refer to Section 7-3, Power Flow Convention of the Retrofit Application Data, supplied with the Retrofit Kit, for additional wiring information and to verify the Phase Convention used on this Breaker Application.

The PT Wires are marked for connection to Phases 1, 2, and 3 with corresponding numbers.

**NOTE:** Before cutting the PT Wires, verify the Phase Convention used on the Breaker Application.

Route the PT Wires to a position suitable for attachment to the proper Breaker Bottom Stabs. Move the PT Wire markers to a position where they will still be attached to the wires after cutting. Cut the wires to length, strip an appropriate length of insulation, and install a .500" ring terminal to each PT Wire.

*For Non-Fused Breakers Only.*

- B. Align the bottom Finger Clusters with the holes in the bottom Breaker Stabs. Using the original mounting hardware, secure the Finger Clusters to the bottom Breaker Stabs.

*For Kits Supplied with a PT Module Only.* Connect the Phase 1, 2, and 3 PT Wires to the appropriate bottom Breaker Stabs using the existing hardware that secures the Finger Clusters to the bottom Breaker Stabs.

*For Fused Breakers Only.*

- C. *For Kits Supplied with a PT Module Only:* Remove one of the bolts securing each Copper Connector to the bottom Breaker Stabs. Connect the Phase 1, 2, and 3 PT Wires to the appropriate bottom Breaker Stabs using the hardware just removed.

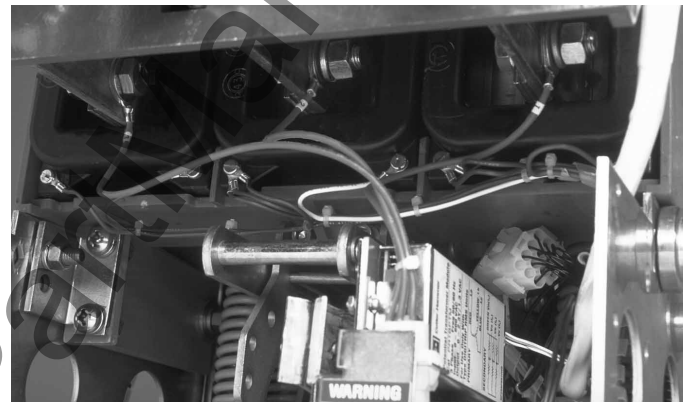

**NOTE:** For detailed instructions for Steps 7-D through 7-I, please refer to the BBC LKD 8 Instruction Manual originally supplied with the Breaker

- D. Using the original components and mounting hardware, reinstall the Fuse Cradle (removed in Step 2-M).
- E. Using the original components and mounting hardware, reinstall the Finger Clusters (removed in Step 2-L) on the bottom Breaker Stabs.
- F. Using the original screws, reconnect the Blown Fuse Indicator Wires (removed in Step 2-K) to their original positions on the outer, upright Copper Connectors.
- G. Using the original components and mounting hardware, reinstall the Fuses (removed in Step 2-J).

- H. Using the original components and mounting hardware, reinstall the Insulation Barriers (removed in Step 2-I) between the Phase 1 & 2 and Phase 2 & 3 Fuses. Note that the two rear mounting bolts must also secure the wire clamps that hold the Blown Fuse Indicator Wiring Harness in place.
- I. Using the original components and mounting hardware, reinstall the top Fuse Insulation Piece (removed in Step 2-H).

For Kits Supplied with a Breaker Mounted CPT Only.

**Step 8: Connecting the HV Wires**

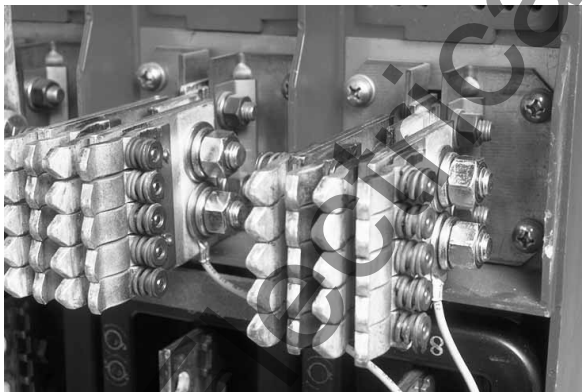
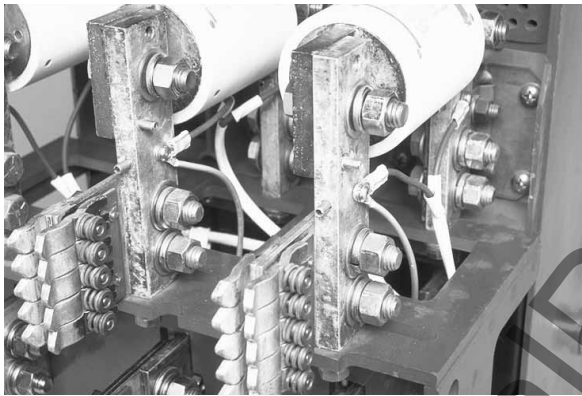

**NOTE:** The power convention of the BBC LKD 8 Series Breakers is normally *Top to Bottom*, meaning the *Top Breaker Stabs* are on the *Line Side* of the Breaker and the *Bottom Breaker Stabs* are on the *Load Side*.

**The HV Wires from the CPT MUST BE ATTACHED to the *Line Side* of the Breaker.** If it is determined that the power flow for the Breaker application is opposite the normal convention, the HV Wires must be attached to the **Bottom Breaker Stabs**. The bolts used to secure the bottom Finger Clusters (Non-Fused Versions) or Copper Connectors (Fused Versions) can be used to connect the HV Wires.

**NOTE:** The *Line Side* HV Wires are longer than necessary and are cut during the following steps. Before cutting the wires, be sure that sufficient length is left so that the connections can be made to the correct Breaker Stabs.

- A. Route the Line Side HV Wires up along the back of the Breaker to the Phase 1 & 2 or Phase 2 & 3 top Breaker Stabs.
- B. Insure that the HV Fuses are still positioned in an accessible location above the Breaker Mounted CPT.



*For Fused Breakers Only.*

- C. The HV Wires should be connected to the Breaker using the same hardware that connects the Finger Cluster-side, Blown Fuse Indicator Wires to the Phase 1 & 2 or Phase 2 & 3 upright Copper Connectors.

Cut the HV Wires to the appropriate length for attachment to the appropriate upright Copper Connectors. Strip an appropriate length of insulation from each HV Wire and attach a .190" ring terminal to each Line Side HV Wire. Using the existing hardware, secure the Line Side HV Wires to the appropriate upright Copper Connectors.

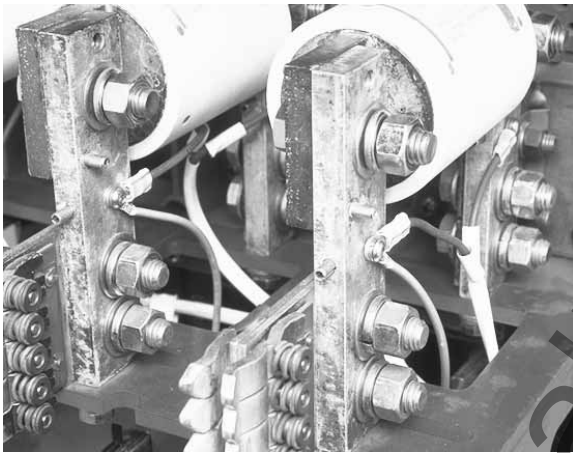

*For Non-Fused Breakers Only.*

- D. The HV Wires should be connected to the Breaker using the same hardware that connects the Finger Clusters to the Phase 1 & 2 or Phase 2 & 3 top Breaker Stabs.

Cut the HV Wires to the appropriate length for attachment to the appropriate top Breaker Stabs. Strip an appropriate length of insulation from each HV Wire and attach a .500" ring terminal to each Line Side HV Wire. Using the existing hardware, secure the Line Side HV Wires to the appropriate top Breaker Stab.

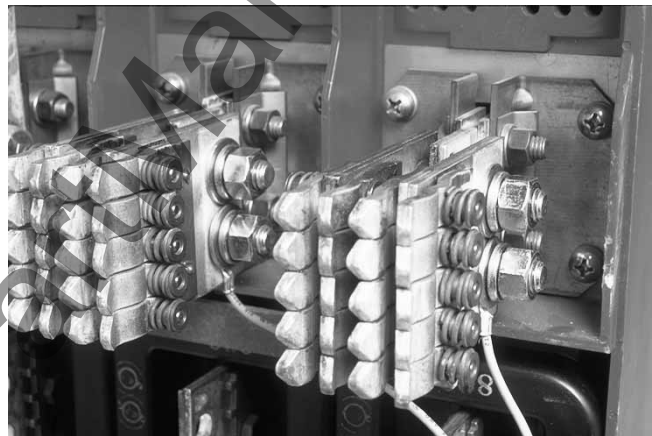

**Step 9: Preparing to Install the Front Mounted Digitrip Retrofit Components**



- C. Using Drilling Plan "D", drill two (2) .219" diameter holes in the left Breaker Center Frame. These will be used later in the Retrofit Process to mount the Trip Rod Assembly.

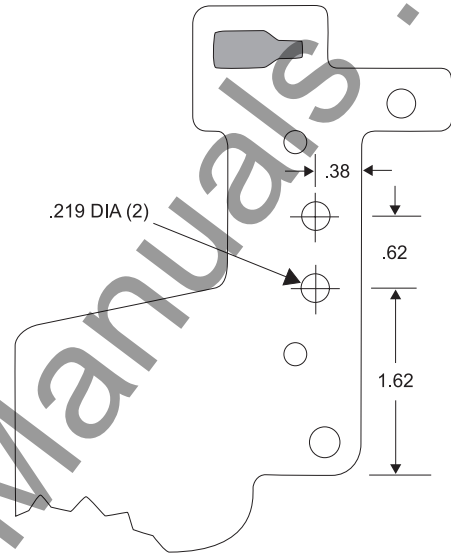

**Drilling Plan "D"**

**NOTE: For the following steps, insure that no drill shavings fall into the Breaker.**

- A. Using Drilling Plan "C", drill two (2) .266" diameter holes in the right Breaker Frame. These will be used later in the Retrofit Process to mount the DTA Assembly.

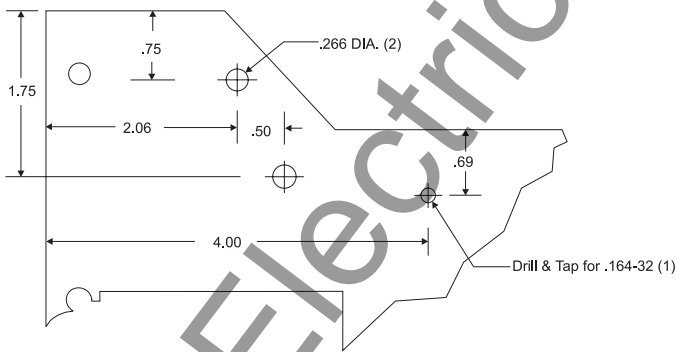

**Drilling Plan "C"**

- B. Again using Drilling Plan "C", drill and tap one (1) hole in the right Breaker Frame to accept a .164-32 screw. This will be used later in the Retrofit Process to secure the External Harness to the side of the Breaker.

**Step 10: Installing the Trip Unit Deck Plate Assembly and Trip Unit**

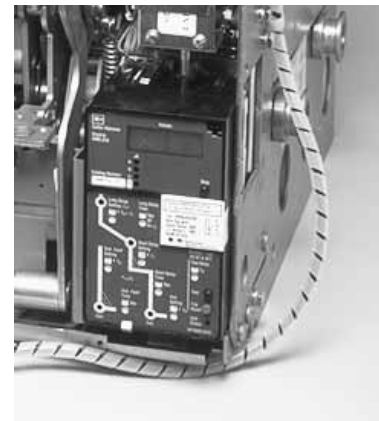

- A. Working from the back of the Trip Unit Deck Plate Assembly, connect the External Harness male connectors to the female connectors on the Deck Plate. Secure the External Harness to the back of the Deck Plate using the (2) wire clamps, (2) .164-16 x .500" thread cutting screws, and (2) flat washers supplied.

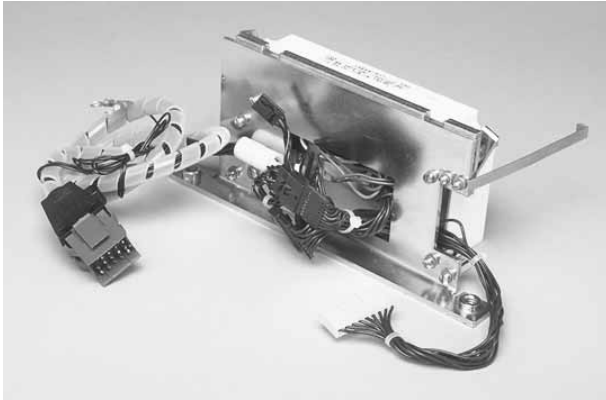

**NOTE: For 510 Basic Retrofit Kits, the External Harness is the plug pictured below. It is to be plugged into the female receptacle on the Trip Unit Deck Plate Assembly.**

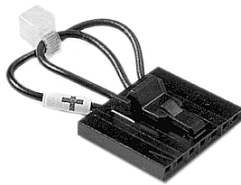

- B. Place the Trip Unit Deck Plate Assembly near the front of the Breaker. Connect the Aux. CT Harness to the female receptacle on the Deck Plate Assembly.
- C. *For Kits Supplied with a PT Module Only:* Connect the PT Extension Harness to the female connector on the External Harness.
- D. *For Kits Supplied with a Breaker Mounted CPT Only:* Remove the 9-position External Harness plug from the female receptacle on the Trip Unit Deck Plate Assembly. Insert the black plug from the CPT Harness into the same female receptacle. Reinsert the External Harness Plug just removed into the female receptacle on the CPT Harness.



- E. Carefully insert most wiring and connections into the cutout in the back of the Trip Unit Deck Plate Assembly. This is important to insure proper clearance when the Trip Unit Deck Plate Assembly is mounted in the Breaker.
- F. Use the wire tie provided to secure all applicable wiring to the External Harness.

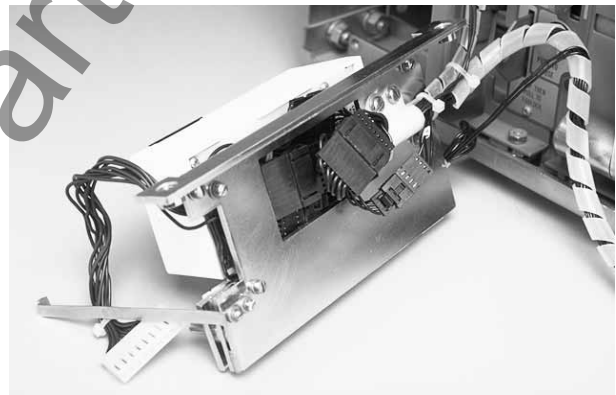

- G. Temporarily route all wiring and harnesses across the Breaker, along the Arc Chute Retaining Bar, to the right side of the Breaker. Align the Trip Unit Deck Plate Assembly with the existing holes near the bottom, front of the right Breaker Frame.

*For 810 & 910 Kits Only:* Note that the Communications Harness Connector must be positioned towards the front of the Breaker.

- H. Secure the Trip Unit Deck Plate Assembly to the right Breaker Frame using the (2) .250-20 x .625" bolts, (2) lock washers, and (2) flat washers supplied.

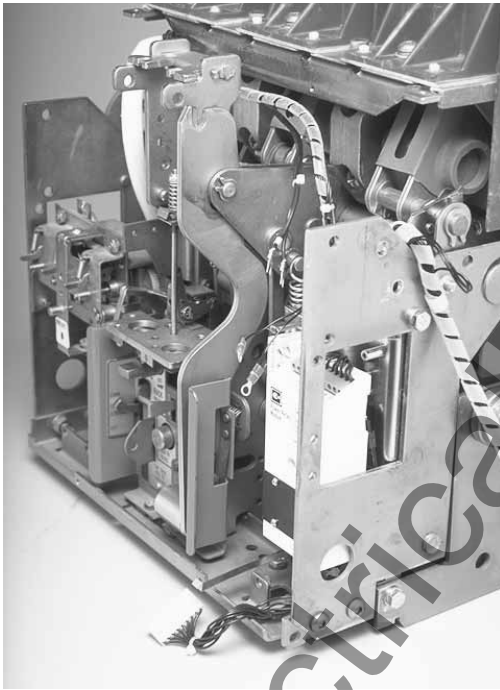

- I. Using the (1) wire clamp, (1) .164-32 x .375" screw (1) lock washer, and (1) flat washer supplied, secure the External Harness to the right Breaker Frame, as shown using the hole drilled in Step 9-B.



- J. *For 810 & 910 Kits Only:* Position the Trip Unit near the right front corner of the Trip Unit Deck Plate Assembly. Insert the male Communications Harness Connector into the female receptacle in the back of the Trip Unit. Note that the metal pins on the Communications Harness Connector must face upwards (towards the top of the Trip Unit). See the Warning Label supplied with the Retrofit Kit for illustration.

**NOTE: This Communications Harness Connector Warning Label will be installed later in the Retrofit Process.**

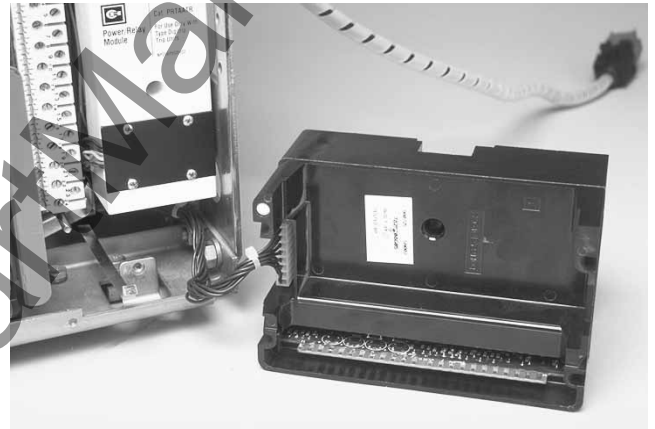

**CAUTION: If the Communications Harness Connector is inserted upside down (metal pins downward), communications problems will occur.**

- K. With the top of the Trip Unit rotated slightly outwards, align the bottom of the Trip Unit with the bottom Trip Unit Deck Plate locking clip. Align the Trip Unit Edge Card with the receptacle on the Trip Unit Deck Plate Assembly then rotate the top of the Trip Unit into the Deck Plate Assembly until the top clip locks the Trip Unit in place.

**NOTE: After the Trip Unit is in place, insure that both the top and bottom locking clips are properly engaged.**

**CAUTION:** Do not apply undue force when installing the Trip Unit. If it does not easily plug into the Deck Plate Assembly, make sure the Edge Card is properly aligned with the receptacle. Applying undue force can damage the Trip Unit and / or Deck Plate Assembly.

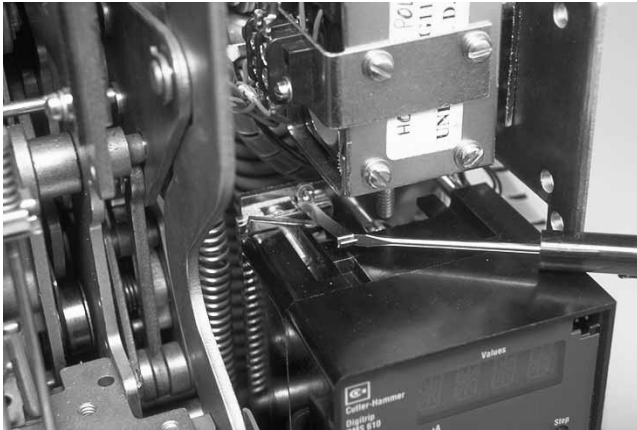

**NOTE:** The Trip Unit Edge Card must seat properly in the Deck Plate Assembly before the Rating Plug is installed.

- L. Insert the Rating Plug into its receptacle in the Trip Unit.

### Step 11: Installing and Adjusting the DTA and Trip Rod Assembly

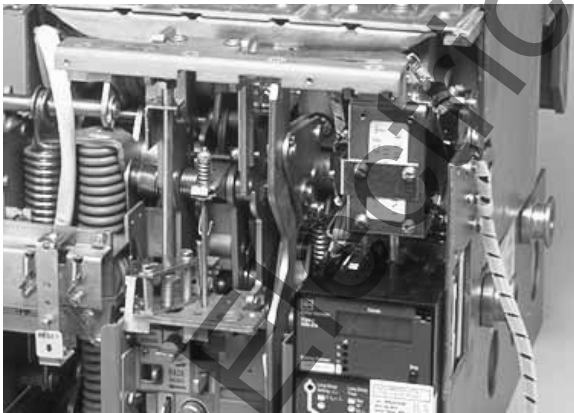

- A. Drill two (2) .152" diameter holes in appropriate locations in the front edge of the Arc Chute Retaining Bracket (removed in Step 2-E). These will be used later in the Retrofit Process to secure the Aux. CT Harness, DTA Wires, and if applicable, the PT Extension Harness and CPT Harness in place.



- B. With the Trip Arm Assembly oriented as shown, insert the Trip Arm Assembly into the Breaker. Note that the Trip Arm Assembly Mounting Bracket must be positioned between the right and left Breaker Center Frames. The Trip Arm Assembly will be mounted in the Breaker later in the Retrofit process.

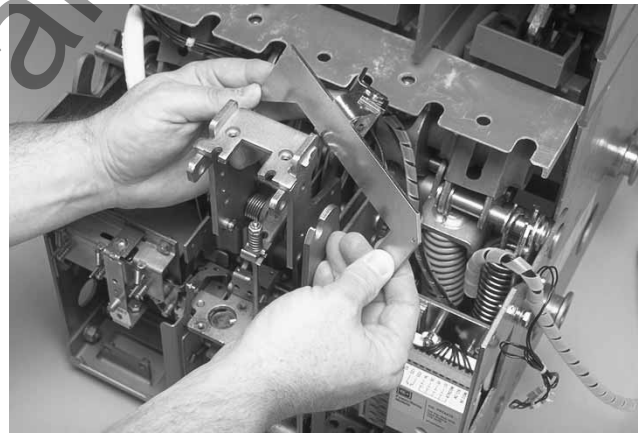

- C. Using the original hardware, reinstall the Arc Chute Retaining Bar and the Arc Chutes removed in Steps 2-D & E respectively.

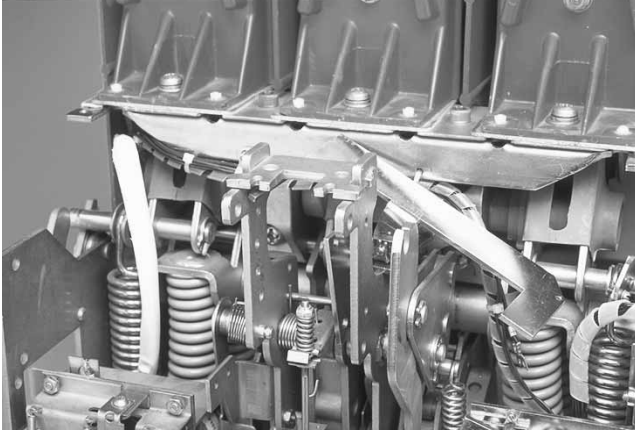

- D. Align the Trip Arm Assembly Mounting Bracket with the existing holes in the right, Breaker Center Frame. Secure the Trip Arm Assembly to the right Breaker Center Plate using the (2) .190-32 x .625" screws, (2) lock washers, (2) flat washers, and the nut plate supplied.

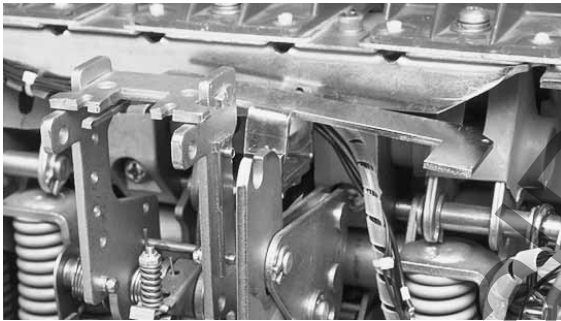

- E. After examining the orientation of the components on the bottom of the Trip Rod Assembly, remove and discard the two (2) nuts installed on the bottom screws. These nuts were installed to keep the components together during shipping.



- F. While holding the Trip Rod Assembly together, align the Trip Rod Assembly, as shown, with the existing holes in the Breaker Center Plate. Secure the Trip Rod Assembly to the Breaker Center Plate using the (2) screws that were pre-installed in the bottom of the Trip Rod Assembly.

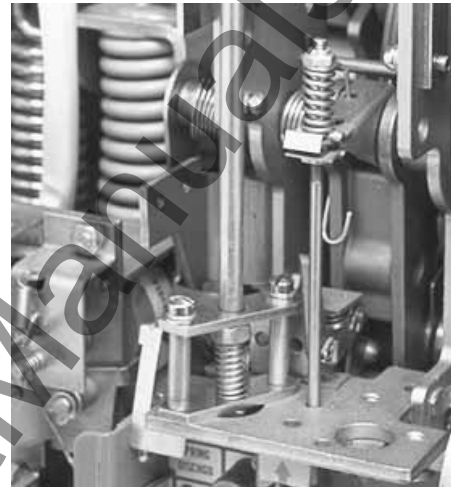

- G. Align the holes in the Trip Rod Assembly Guide Bracket with the holes drilled in the left Breaker Center Frame in Step 9-C. Secure the Guide Bracket to the left Breaker Center Plate using the (2) .190-32 x .625" screws, (2) lock washers, (4) flat washers, and (2) nuts supplied.

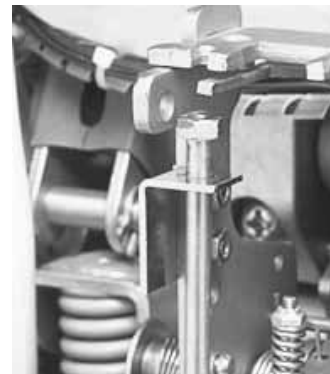

- H. Remove the locking screw and open the Reset Spring Connecting Link and install it over the Breaker Cross Bar, as shown, between the right Charging Spring and the right Breaker Frame. Note that the side with the threaded hole must be positioned facing the middle of the Breaker.



Close the Reset Spring Connecting Link around the Breaker Cross Bar. Secure the Connecting Link in the CLOSED position by inserting and tightening the locking screw.



- I. Route the DTA Extension Harness to the right side of the Breaker. Connect the wire from the DTA Extension Harness marked with "+" to the terminal to which the "+" DTA Wire is attached and the unmarked wire to the other terminal.

- J. Align the DTA Assembly, as shown, with the holes drilled in the right Breaker Frame in Step 9-A. Secure the DTA Assembly to the Breaker using the (2).250-20 x .625" bolts, (2) lock washers, and (2) flat washers supplied.



- K. *For Kits Supplied with an Auxiliary Switch Only:* Using diagonals, cut two (2) inches off the end of the Microswitch arm. Align the Microswitch, as shown, with the holes in the Auxiliary Switch Mounting Bracket. Secure the Microswitch to the Auxiliary Switch Mounting Bracket using the (2).138-32 x 1.00" screws, (2) lock washers, and (2) flat washers supplied.

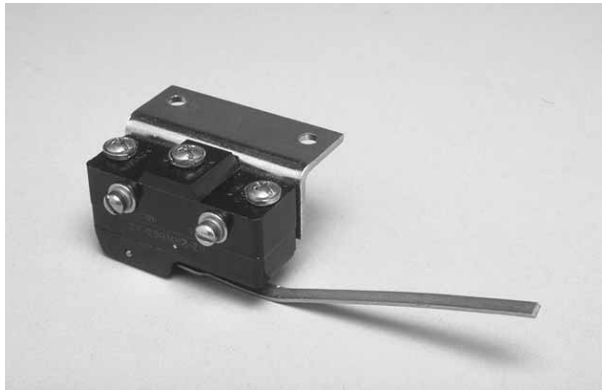

Slightly bend the Auxiliary Switch Arm as shown. Align the Auxiliary Switch Assembly with the existing holes in the top of the DTA Assembly. Secure the Auxiliary Switch Assembly to the DTA Assembly using the (2).164-32 x .312" Pan lock screws and (2) flat washers supplied.

- L. Install the Reset Spring, as shown, between the Reset Spring Connecting Link and the Trip Plate.

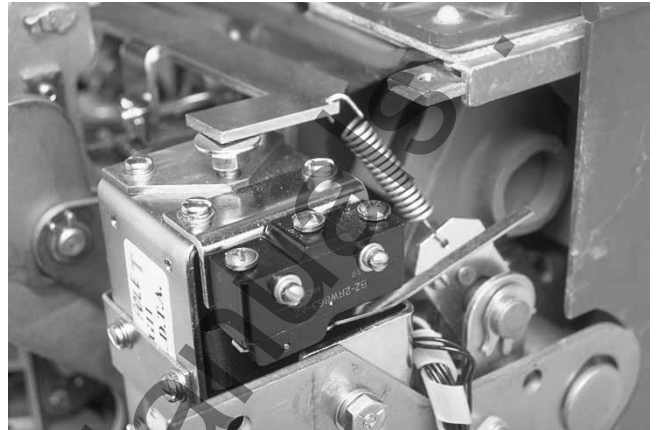

- M. Turn the DTA Adjusting nut down the DTA Shaft. Apply the supplied Loc-Tite® to the threads of the DTA Shaft. As you wind the DTA Adjusting nut up the DTA Shaft, observe the gap between the Trip Shaft and the bottom surface of the left side of the Trip Arm. While applying slight downward pressure on the Trip Shaft, move the DTA Adjusting Nut up the DTA Shaft until a gap of .03" is achieved between the top of the Trip Shaft and the bottom of the Trip Arm.

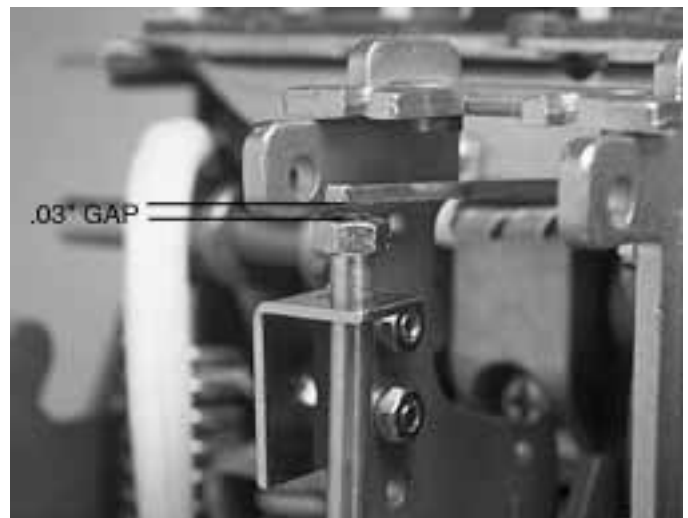

N. Connect a 24 VDC power supply to the DTA terminals; positive to positive and negative to negative. Close the Breaker manually. Energize the DTA to trip the Breaker; de-energize when the Breaker trips. Make certain that the DTA resets. If the Breaker fails to properly trip or reset, make the necessary adjustments to insure a .03" gap between the top of the Trip Shaft and the bottom of the Trip Arm. Repeat the procedure until proper trip and reset is achieved.

### Step 12: Final Wire Routing and Connection

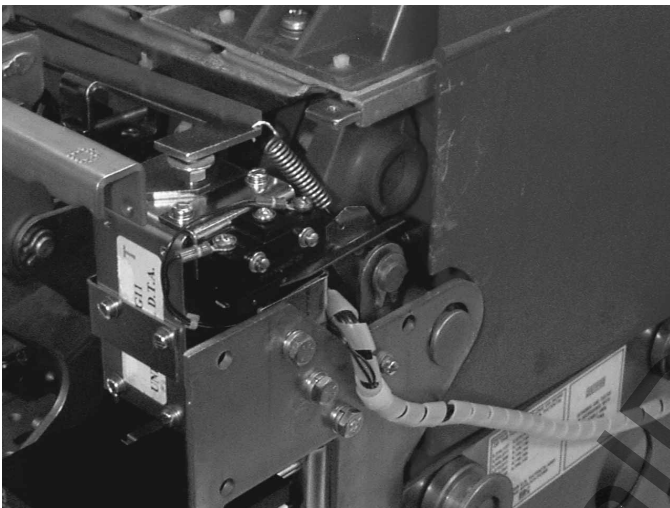

A. *For Kits Supplied with an Auxiliary Switch Only.* Route the Auxiliary Switch Wires from the External Harness to the Auxiliary Switch. Connect one wire to normally closed terminal and the other wire to the common terminal of the Auxiliary Switch.

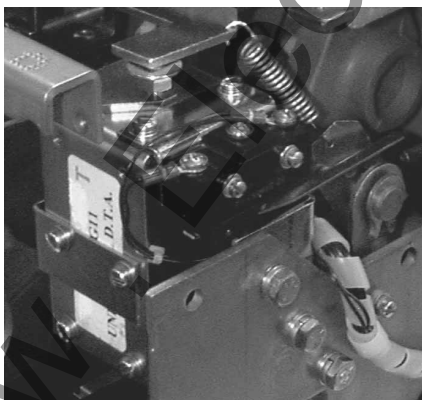

B. Using the holes drilled in Step 9-D, secure the Aux. CT Harness, DTA Extension Harness, and (if applicable) the PT Extension Harness and CPT Wires to the front of the Arc Chute retaining Bar using the (1) wire clamp, (1) .164-16 x .500" thread cutting screw, (1) flat washer, and (1) wire tie supplied.

C. Use the wire ties provided to dress all wires and harnesses to keep them away from any moving parts within the Breaker.

### Step 13: Breaker Front Plate Modifications and Final Breaker Reassembly



- A. Using Drilling / Cutting Plan "E", drill and tap five (5) holes in the Breaker Front Plate to accept .138-32 screws.

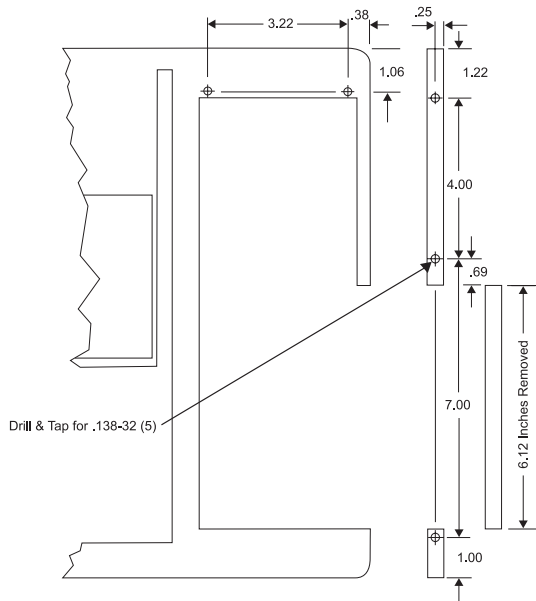

Drilling / Cutting Plan "E"

- B. Again referring to Drilling / Cutting Plan "E", remove the identified 6.12" section from the right side of the Breaker Front Plate.

**NOTE: After cutting, file the metal edges of the Breaker Front Plate to insure that there are no sharp edges.**



- C. Align the Trip Unit Metal Cover, as shown, with the holes just drilled in the Breaker Front Plate. Secure the Trip Unit Metal Cover to the Breaker Front Plate using the (2) .138-32 x 1.00" screws, (4) flat washers, (2) lock washers, and (2) nuts supplied to secure the top and the (3) .138-32 x .375" Pan screws and (3) lock washers to secure the side.



- D. *For 810 & 910 Kits Only:* Attach the Communications Harness Connector Warning Label, as shown, to the inside of the Trip Unit Cover Assembly. If the Retrofitter opts to attach this label in a different position, it must be in a prominent position.



- E. *For Kits Supplied with a Breaker Mounted CPT Only:* Attach the appropriate CPT Voltage Warning Label for the Breaker on the outside of the Trip Unit Cover. If the Retrofitter opts to attach this label in a different position, it must be in a prominent position.

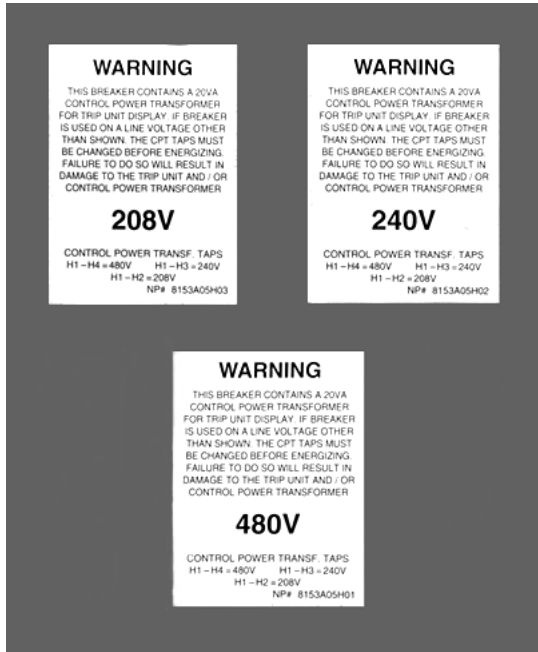

#### Step 14: Testing the Breaker

- A. Measure the force necessary to trip the Breaker at the point where the Trip Finger impacts the Trip Rod. The force necessary to trip the Breaker **MUST NOT EXCEED THREE (3) lbs.**

- B. The Retrofit must be tested using primary injection. Refer to Section 8 of the Instructions for the *Application of Digitrip RMS Retrofit Kits on Power Circuit Breakers* (Publication AD 33-855-2), supplied with the Retrofit Kit, for detailed testing procedures and specifications. For test information specific to the Trip Unit, refer to the IL publication supplied with the Retrofit Kit (see the Pick List for the IL number).

- C. While Section 8 of the *Instructions for the Application of Digitrip RMS Retrofit Kits on Power Circuit Breakers* provides the information necessary for testing the Breaker, please keep the following notes in mind when reviewing other sections of the publication.

**Caution:** When all testing is complete, the Trip Unit must be reset. Failure to do so may cause the battery in the Rating plug to run down.

#### Notes:

1. **For All Kits Other Than 510 Basic.** If testing the Breaker with Short Delay or Ground Fault functions, be sure to either plug in the Cell Harness Assembly or use the Zone Interlock Shorting Plug. Failure to do so may result in shorter than expected trip times.
2. **For 810 and 910 Kits Only.** Without any power applied to the system (neither the 120 volt power supply nor the Aux. Power Module connected), plug the External Harness into the Cell Harness and check the impedance between COM 1 and COM 2. The impedance should be between one (1) and three (3) ohms. If the impedance is not within this range, trace the wiring and examine each connection to assure its integrity.

Confirm that the PowerNet communication wiring is correct by following the procedures detailed in Section 7.4 of the Instructions for the Application of Digitrip RMS Retrofit Kits on Power Circuit Breakers. Note that for 810 and 910 Kits, the impedance between COM 1 and COM 2 should be between one (1) and three (3) ohms.

When testing is complete, disconnect the External Harness from the Cell Harness. Final External Harness connection will be performed later in the Retrofit Process.

- D. Install the Breaker Top Plate Mounting Bracket using the original hardware (removed in Step 2-C).

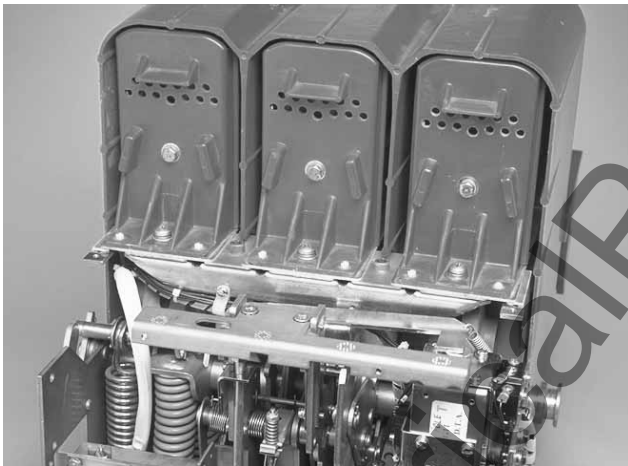

- E. Install the Breaker Top Plate using the original mounting hardware (removed in Step 2-B).



- F. Install the modified Breaker Front Plate using the original mounting hardware (removed in Step 2-A).
- G. Align the Trip Unit Plexiglas Cover with the Trip Unit. Note that the two (2) access holes in the Trip Unit Plexiglas Cover must be oriented towards the right side of the Trip Unit and that the bottom Trip Unit Deck Plate Locking Clip extends slightly through the hole near the bottom left of the cover.
- H. Attach the Digitrip Nameplate on the outside of the Breaker Front Plate in a prominent position.



*For Kits Supplied with a Cell Harness Only.*

### Step 15: Mounting the Cell Harness

- A. The Cell Harness is to be mounted in the Breaker Cell. The connector end is to be mounted on the right front side of the Cell, in a location suitable for connection with the External Harness. The Terminal Blocks can be mounted anywhere space is available in the Cell as long as connection to the External Harness can be made.
- B. Route the Cell Harness wiring to keep it away from any moving parts within the Cell Housing.

---

**Step 16: Installing the Retrofitted Breaker in the Cell**

---

**WARNING**

---

Do not leave the Breaker in an intermediate position in the switchgear cell. Always leave it in the **CONNECTED, DISCONNECTED, or (Optional) TEST** position. Failure to do so could lead to improper positioning of the Breaker and flashover, causing death, serious personal injury, and / or property damage.

**NOTE:** It is the responsibility of the Retrofitter to insure proper Breaker / Cell fit. When racking the Breaker into the Connected position, the Retrofitter **MUST FOLLOW BOTH** the manufacturer's instructions and the customer's safety standards and procedures for racking a Breaker into the Connected position.

- A. With the Breaker in the Open position and the springs discharged, slowly rack the Breaker into the Connected position, making sure there is no interference or binding. The Breaker should rack smoothly and without mechanical interference between any Breaker and Cell parts. The Retrofitter will feel some resistance when the primary fingers connect onto the stabs of the Cell. This is normal.

However, if any unusual resistance is detected that could be abnormal interference between the Breaker and Cell parts, stop immediately and move the Breaker out of the Connected position. Examine what is causing the interference and correct the situation.

## Digitrip Retrofit Kit Installation Components for BBC LKD 8 Breakers

| Step           | Description                                    | Style No.     | Qty. | Comment    |
|----------------|--|---------------|------|------------|
| Step 3         | Sensor   | See Pick List | 3    |            |
|                | Sensor Mounting Parts                          | 4A35843G04    | 1    |            |
|                | Spacer   |               | 2    |            |
|                | .250 - 20 × 1.00 Lng. Hex Bolt                 |               | 2    |            |
|                | .250 Flat Washer Stl.                          |               | 6    |            |
|                | .250 Lock Washer Stl.                          |               | 2    |            |
| Step 4         | Auxiliary CT Harness                           | 6502C84G02    | 1    |            |
|                | DTA Extension Harness                          |               | 1    |            |
|                | PT Extension Harness                           | 6502C85G01    | 1    | Comm. Only |
|                | CPT Harness                                    | From Step 6   | 1    | CPT Only   |
|                | Spiral Wire Wrap (24")                         | From Step 10  | 1    |            |
| Step 5         | Aux. CT Module                                 | 6506C45G01    | 1    |            |
|                | Aux. CT Module Mounting Parts                  | 4A35843G05    | 1    |            |
|                | .190 - 16 × .500 Lng. Screw T.C.               |               | 3    |            |
|                | .190 Flat Washer Stl.                          |               | 3    |            |
|                | .190 Lock Washer Stl.                          |               | 3    |            |
|                | PT Module Kit                                  | 6502C82G01    | 1    | Comm. Only |
|                | .138 Flat Washer Stl.                          |               | 4    | Comm. Only |
|                | .138 Lock Washer Stl.                          |               | 2    | Comm. Only |
|                | .138-32 Nut Hex Stl.                           |               | 2    | Comm. Only |
|                | Ring Terminals (.190, .250, .312, .375, .500), |               | 3    | Each Size  |
|                |  |               |      | Comm. Only |
|                | PT Module Mounting Parts                       | 4A35843G06    | 1    | Comm. Only |
|                | Mounting Bracket                               |               | 1    | Comm. Only |
|                | Glass Poly Insulation                          |               | 1    | Comm. Only |
|                | .190 - 16 × .500 Lng. Screw T.C.               |               | 2    | Comm. Only |
|                | .190 Flat Washer Stl.                          |               | 2    | Comm. Only |
|                | .190 Lock Washer Stl.                          |               | 2    | Comm. Only |
|                | .138-32 × .500 Lng. Screw                      |               | 2    | Comm. Only |
|                | Warning Plate Mounting Parts                   | 4A35843G07    | 1    | Comm. Only |
|                | .112 - 40 × .25 Screw Fil.                     |               | 2    | Comm. Only |
|                | .112 Flat Washer Stl.                          |               | 2    | Comm. Only |
|                | .112 Lock Washer Stl.                          |               | 2    | Comm. Only |
|                | PT Warning Label                               |               | 1    | Comm. Only |
| Sensor Harness | See Pick List                                  | 1             |      |            |

| Step                  | Description   | Style No.     | Qty. | Comment                |
|-----------------------|---|---------------|------|------------------------|
| Step 6                | Breaker Mounted CPT Kit                             | 8259A91G05    | 1    | CPT Only               |
|                       | .138-20 × .375 Lng. Screw T. C.                     |               | 2    | CPT Only               |
|                       | Ring Terminals (.138, .190, .250, .312, .375, .500) |               | 2    | Each Size,<br>CPT Only |
|                       | CPT Mounting Parts                                  | 4A35843G20    | 1    | CPT Only               |
|                       | .190 - 32 × .625 Lng. Screw Fil.                    |               | 4    | CPT Only               |
|                       | .190 Flat Washer Stl.                               |               | 8    | CPT Only               |
|                       | .190 Lock Washer Stl.                               |               | 4    | CPT Only               |
|                       | .190 - 32 Nut Hex Stl.                              |               | 4    | CPT Only               |
|                       | .138 Flat Washer Stl.                               |               | 2    | CPT Only               |
|                       | .138 Lock Washer Stl.                               |               | 2    | CPT Only               |
|                       | Warning Label (208, 240, & 480 Volt)                |               | 1    | Each, CPT Only         |
| Step 7                | Ring Terminals (.500)                               | From Step 5   | 3    | Comm. Only             |
| Step 8                | Ring Terminals                                      |               |      |                        |
|                       | .190 - Fused Breakers                               | From Step 6   | 2    | CPT Only               |
|                       | .500 - Non-Fused Breakers                           | From Step 6   | 2    | CPT Only               |
| Step 10               | Trip Unit   | See Pick List | 1    |                        |
|                       | Rating Plug   | See Pick List | 1    |                        |
|                       | External Harness 6502C83G__                         |               | 1    |                        |
|                       | Trip Unit Deck Plate Assembly                       | See Pick List | 1    |                        |
|                       | Communications Harness Warning Label                |               | 1    | Comm. Only             |
|                       | Deck Plate Mounting Parts                           | 4A35843G08    | 1    |                        |
|                       | .250 - 20 × .625 Lng. Hex Bolt                      |               | 2    |                        |
|                       | .250 Flat Washer Stl.                               |               | 2    |                        |
|                       | .250 Lock Washer Stl.                               |               | 2    |                        |
|                       | .164 - 16 × .500 Lng. Screw T.C.                    |               | 2    |                        |
|                       | .164 Flat Washer Stl.                               |               | 2    |                        |
|                       | Digitrip Nameplate                                  |               | 1    |                        |
|                       | Spiral Wire Wrap (24")                              |               | 1    |                        |
|                       | Wire Clamp Nylon                                    |               | 2    |                        |
|                       | External Harness Mounting Parts                     | 4A35843G09    | 1    |                        |
|                       | .164 - 32 × .375 Lng. Screw Fil.                    |               | 1    |                        |
| .164 Flat Washer Stl. |   | 1             |      |                        |
| .164 Lock Washer Stl. |   | 1             |      |                        |
| Wire Clamp Nylon      |   | 1             |      |                        |
| Wire Tie Nylon        | From Step 12  | 1             |      |                        |
| Step 11               | DTA Assembly  | 4A35843G33    | 1    |                        |
|                       | DTA Mounting Parts                                  | 4A35843G10    | 1    |                        |
|                       | .250 - 20 × .625 Lng. Hex Bolt                      |               | 2    |                        |
|                       | .250 Flat Washer Stl.                               |               | 2    |                        |
|                       | .250 Lock Washer Stl.                               |               | 2    |                        |
|                       | Loc-Tite®   |               | 1    |                        |
|                       | Trip Arm Assembly Mounting Parts                    | 4A35843G11    | 1    |                        |
|                       | Trip Arm Assembly                                   |               | 1    |                        |
|                       | .190 - 32 × .625 Lng. Screw Fil.                    |               | 2    |                        |
|                       | .190 Flat Washer Stl.                               |               | 2    |                        |
| .190 Lock Washer Stl. |   | 2             |      |                        |

| Step    | Description                          | Style No.  | Qty. | Comment           |
|---------|--------------------------------------|------------|------|-------------------|
| Step 11 | Nut Plate Stl.                       |            | 1    |                   |
| (Cont.) | Trip Rod Assembly Mounting Parts     | 4A35843G12 | 1    |                   |
|         | Trip Rod Assembly                    |            | 1    |                   |
|         | .190 - 32 × .625 Lng. Screw Fil.     |            | 2    |                   |
|         | .190 Flat Washer Stl.                |            | 4    |                   |
|         | .190 Lock Washer Stl.                |            | 2    |                   |
|         | .190 - 32 Hex Nut Stl.               |            | 2    |                   |
|         | Reset Spring Parts                   | 4A35843G13 | 1    |                   |
|         | Reset Spring Mounting                |            | 1    |                   |
|         | Spring Reset                         |            | 1    |                   |
|         | Aux. Switch Kit                      | 4A35843G02 | 1    | Comm. Only        |
|         | Microswitch                          |            | 1    | Comm. Only        |
|         | Mounting Bracket                     |            | 1    | Comm. Only        |
|         | .164 - 32 × .312 Lng. Screw Pan Lock |            | 2    | Comm. Only        |
|         | .164 Flat Washer Stl.                |            | 2    | Comm. Only        |
|         | .138 - 32 × 1.00 Lng. Screw Fil.     |            | 2    | Comm. Only        |
|         | .138 Flat Washer Stl.                |            | 2    | Comm. Only        |
|         | .138 Lock Washer Stl.                |            | 2    | Comm. Only        |
| Step 12 | Harness Mounting Parts               | 4A35843G14 | 1    |                   |
|         | .164 - 16 × .500 Lng. Screws T.C.    |            | 1    |                   |
|         | .164 Flat Washer Stl.                |            | 1    |                   |
|         | Wire Clamp Nylon                     |            | 1    |                   |
|         | Wire Tie Nylon                       |            | 12   |                   |
| Step 13 | Trip Unit Cover Mounting Parts       | 4A35843G15 | 1    |                   |
|         | Trip Unit Metal Cover                |            | 1    |                   |
|         | Trip Unit Plexiglas Cover            |            | 1    |                   |
|         | .138 - 32 × 1.00 Lng. Screw Fil.     |            | 2    |                   |
|         | .138 - 32 × .375 Lng. Screw Pan      |            | 3    |                   |
|         | .138 - 20 × .375 Lng. Screw T. C.    |            | 4    |                   |
|         | .138 Flat Washer Stl.                |            | 8    |                   |
|         | .138 Lock Washer Stl.                |            | 9    |                   |
|         | .138 - 32 Hex Nut Stl.               |            | 2    |                   |
| Step 15 | Cell Harness                         | 6503C57G__ | 1    | Except 510 Basics |

NOTE: Due to the wide vintage of Breakers and the multiple functions of the Retrofit components, some excess hardware may remain when the Retrofit is complete.

### Torque Values for General Mounting and Screw Size Conversion

| Decimal Size (in) | Standard Size | Torque (in-lbs) | Torque (ft-lbs) |
|-------------------|---------------|-----------------|-----------------|
| .112              | 4-40          | 10              | 0.8             |
| .138              | 6-32          | 18              | 1.5             |
| .164              | 8-32          | 36              | 3.0             |
| .190              | 10-32         | 46              | 3.8             |
| .250              | 1/4-20        | 100             | 8.3             |
| .312              | 5/16-18       | 206             | 17.2            |
| .375              | 3/8-16        | 356             | 29.7            |
| .438              | 7/16-14       | 572             | 47.7            |
| .500              | 1/2-13        | 856             | 71.3            |

### Torque Values for Copper BUS Connectors

| Decimal Size (in) | Standard Size | Torque (in-lbs) | Torque (ft-lbs) |
|-------------------|---------------|-----------------|-----------------|
| .250              | 1/4-20        | 60              | 5               |
| .312              | 5/16-18       | 144             | 12              |
| .375              | 3/8-06        | 240             | 20              |
| .500              | 1/2-13        | 600             | 50              |

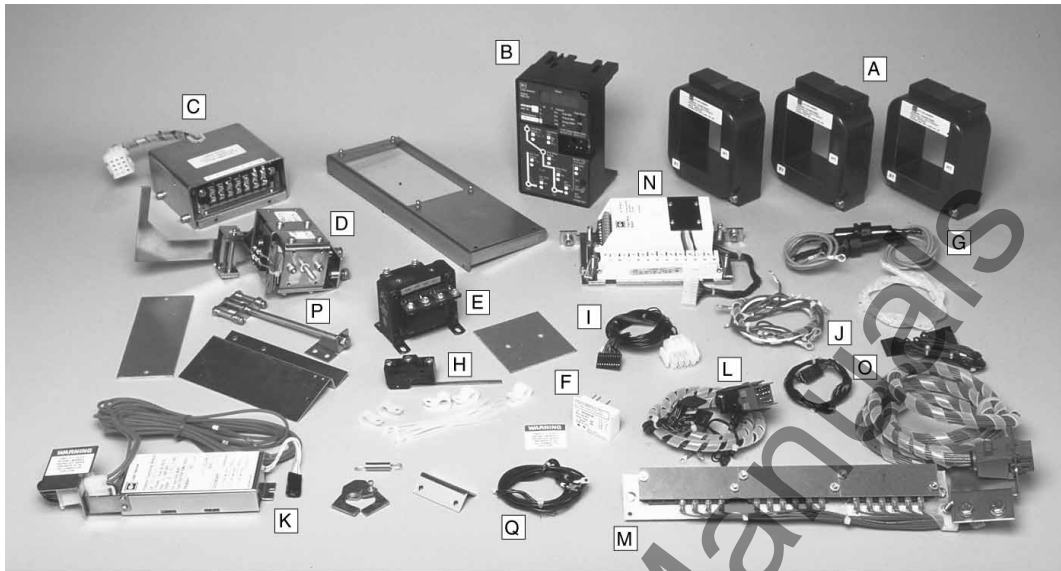

- |                               |                           |
|-------------------------------|---------------------------|
| A. Sensors                    | I. Aux. CT Harness        |
| B. Trip Unit                  | J. Sensor Harness         |
| C. Aux. CT Module             | K. PT Module              |
| D. Direct Trip Actuator (DTA) | L. External Harness       |
| E. CPT Kit (Optional)         | M. Cell Terminal Block    |
| F. Rating Plug                | N. Trip Unit Deck Plate   |
| G. HV Wires                   | O. P.T. Extension Harness |
| H. Aux. Switch                | P. Trip Rod Assembly      |
|                               | Q. DTA Extension Harness  |

*We wish to thank you for purchasing the Digitrip Retrofit System. Digitrip Retrofit Kits are designed and manufactured in America with pride. All the components are engineered to fit the existing Circuit Breaker with little or no modifications to the existing Breaker. However due to the wide variety and vintage of Breakers in use today, an occasional problem may arise. Please contact us with any questions, comments or concerns.*

Phone: **1-800-937-5487**

Fax: (724) 779-5899

The instructions for installation, testing, maintenance, or repair herein are provided for the use of the product in general commercial applications and may not be appropriate for use in nuclear applications. Additional instructions may be available upon specific request to replace, amend, or supplement these instructions to qualify them for use with the product in safety-related applications in a nuclear facility.

The information, recommendations, descriptions, and safety notations in this document are based on Cutler-Hammer's experience and judgment with respect to Retrofitting of Power Breakers. This information should not be considered to be all inclusive or covering all contingencies. If further information is required, Cutler-Hammer should be consulted.

**NO WARRANTIES, EXPRESSED OR IMPLIED, INCLUDING WARRANTIES OF FITNESS FOR A PARTICULAR PURPOSE OR MERCHANTABILITY, OR WARRANTIES ARISING FROM COURSE OF DEALING OR USAGE OF TRADE, ARE MADE REGARDING THE INFORMATION, RECOMMENDATIONS AND DESCRIPTIONS CONTAINED HEREIN.** In no event will Cutler-Hammer be responsible to the user in contract, in tort (including negligence), strict liability or otherwise, for any special, indirect, incidental, or consequential damage or loss whatsoever, including but not limited to damage to or loss of use of equipment, plant or power system, cost of capital, loss of profits or revenues, cost of replacement power, additional expenses in the use of existing power facilities, or claims against the user by its customers resulting from the use of the information, recommendations, and descriptions contained herein.

## Cutler-Hammer

130 Commonwealth Drive  
Warrendale, PA 15086

Effective October, 2000

Printed in U.S.A. - K

**EAT•N**