

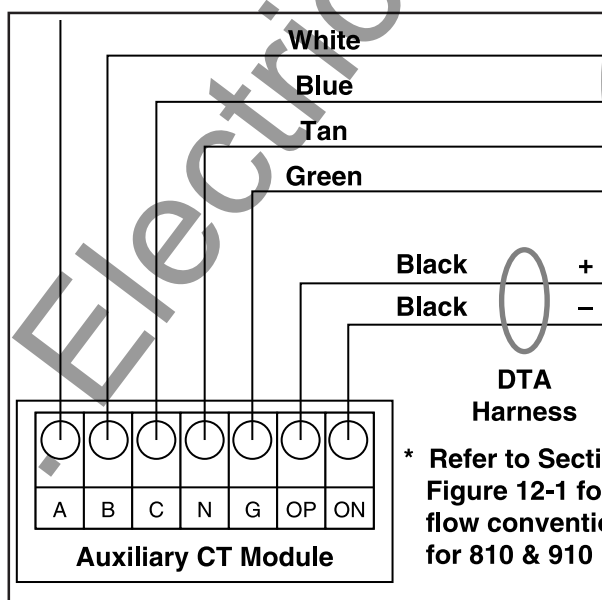

Instructions for the Application of Digitrip RMS 510, 610, 810, & 910 Retrofit Kits on Power Circuit Breakers

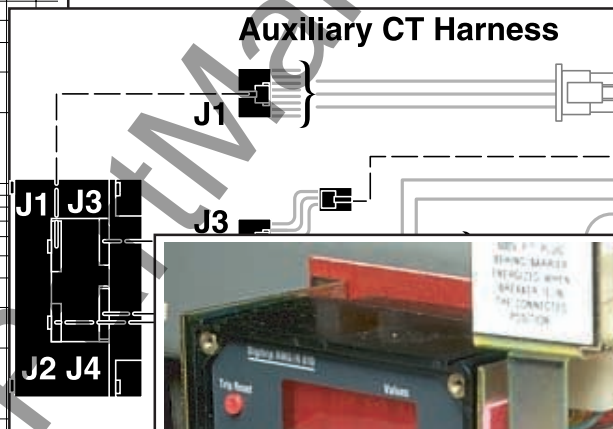

* Refer to Section 12.1 for flow convention for 810 & 910 kits.

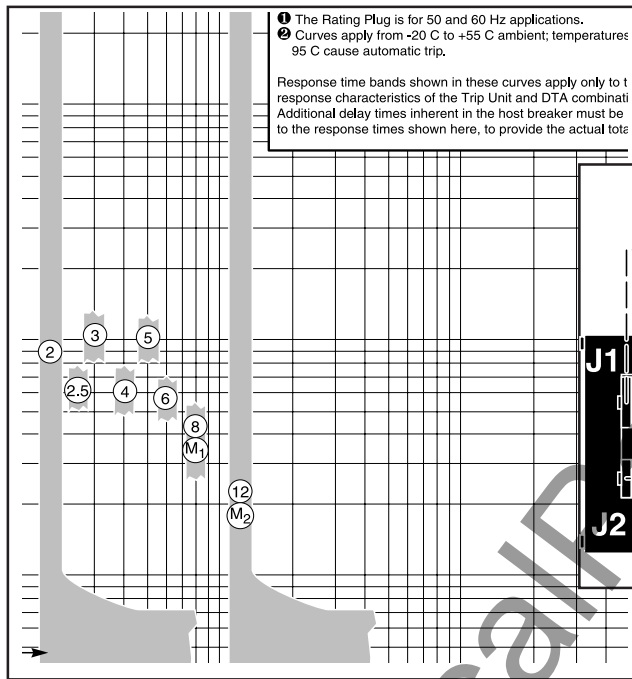

www.ElectricalPartManuals.com



Instructions for the Application of Digitrip RMS 510, 610, 810, & 910 Retrofit Kits on Power Circuit Breakers

CONTENTS

Description

Section 1 General Information and Safety Precautions 5

1.1 Safety Precautions 5

1.2 Introduction 6

1.3 Warranty Disclaimer and Liability Limitation 6

Section 2 Digitrip RMS Retrofit Kits, Rating Plugs, and Accessories 7

2.1 Digitrip RMS Retrofit Kits 7

2.2 Retrofit Kit Installation Requirements 7

2.3 The Retrofit Process 8

2.4 Digitrip RMS Retrofit Kit Accessories 8

Section 3 The Digitrip RMS Trip System 11

3.1 Digitrip RMS Overcurrent Protection 11

3.2 Current Sensors and Sensor Wiring Harness 11

3.3 Auxiliary CT Module and Auxiliary CT Harness 11

3.4 Digitrip RMS Trip Unit and Power Relay Module (ATR) 11

3.5 Long Time Memory Function 17

3.6 Discriminator (High Initial Current Release) 17

3.7 Digitrip RMS Direct Trip Actuator (DTA) and Auxiliary Switch Kit (See Figure 3-6) 18

3.8 Digitrip RMS Retrofit Rating Plug and Battery 19

3.9 External Harness 20

3.10 Potential Transformer (PT) Module 20

3.11 Cell Harness Assembly 20

3.12 Breaker Mounted Control Power Transformer (CPT) 20

Section 4 Digitrip RMS 510 Basic Retrofit Kits (Without Zone Interlocks) 21

4.1 Digitrip RMS 510 Basic Retrofit Kit Selection and Content 21

4.2 Digitrip RMS 510 Basic Retrofit Kit Features 21

Section 5 Digitrip RMS 510 Retrofit Kits (With Zone Interlocks) 23

5.1 Digitrip RMS 510 Retrofit Kit (With Zone Interlocks) Selection and Content 23

5.2 Digitrip RMS 510 Retrofit Kit (With Zone Interlocks) Features 23

Section 6 Digitrip RMS 610 Retrofit Kits 25

6.1 Digitrip RMS 610 Retrofit Kit Selection and Content 25

6.2 Digitrip RMS 610 Retrofit Kit Features ... 25

Section 7 Digitrip RMS 810 & 910 Retrofit Kits 27

7.1 Digitrip RMS 810 & 910 Retrofit Kit Selection and Content 27

7.2 Digitrip RMS 810 & 910 Retrofit Kit Features 27

7.3 Power Flow Convention 29

7.4 PowerNet Communications Wiring Checkout 30

Section 8 Testing Retrofitted Breakers	31	Section 12 Detailed Wiring of Harnesses and Related Components	63
8.1 Dielectric and Meggar Testing	31	12.1 Sensor Harness Wiring	63
8.2 Trip System Testing – General Notes	31	12.2 Auxiliary CT Harness Wiring	63
8.3 Recommended Test Accessories	32	12.3 Auxiliary CT Module Wiring	63
8.4 Explanation of Test Procedures	33	Section 13 References	73
8.5 Primary Injection Testing	35	Section 14 Explanation of Time Current Curves	75
8.5.1 Primary Injection Test Procedures ...	35	14.1 Explanation of the Time Current Curves (LSI)	75
8.6 Digitrip RMS Self-Testing System	39		
8.6.1 Self-Testing Procedures	39		
8.7 Testing Digitrip with the DS Breaker			
Secondary Injection Test Kit	42		
8.7.1 Secondary Injection Testing	43		
8.7.2 Secondary Injection Test Procedures	43		
8.8 Circuit Breaker Checkout and Bench Test	46		
Section 9 Operation	47	Figures	
9.1 Breaker Insertion in Switchgear Cell and Power Up	47	3-1 Digitrip Retrofit System	13
9.2 Information Available to Operator While Breaker Is in Service	48	3-2 Digitrip RMS Long Time / Short Time-Current Curves (LS)	14
9.3 Information Available in the Event of a Trip	49	3-3 Digitrip RMS Instantaneous Time-Current Curve (I)	15
9.4 Resetting The Trip Unit After a Trip	50	3-4a Digitrip RMS Ground Fault Protection Time-Current Curve (G)	16
9.5 Removing the Breaker From the CONNECT Position	50	3-4b Digitrip RMS Ground Fault Protection Time-Current Curve (G)	17
Section 10 Digitrip RMS Retrofit Switchgear Assembly Applications	51	3-5 Disabling the Long Time Memory (LTM) Function	18
10.1 Zone Interlocking	51	3-6 Digitrip RMS Direct Trip Actuator (DTA) ...	19
10.1.1 Zone Selective Interlocking	51	4-1 Digitrip RMS 510 Basic Wiring	22
10.2 Setting Digitrip RMS Communications Address (Digitrip RMS 810 & 910 Kits Only)	54	5-1 Digitrip RMS 510 Wiring	24
10.3 Identification of Trip Unit, Breaker, and Switchgear Cell	57	6-1 Digitrip RMS 610 Wiring	26
10.4 The Power Relay Module (ATR)	57	7-1 Digitrip RMS 810 & 910 Wiring	28
10.5 Communications and PowerNet	57	7-2 Power Flow Conventions	29
Section 11 Maintenance, Warranty, and Service Information	61	8-1 Pick-up Test and Time Test	32
11.1 Preventative Maintenance Program	61	8-2 Adapter Methods	42
11.2 Breaker Maintenance	61	10-1 Zone Selective Interlocking	51
11.3 Warranty Procedure	61	10-2 Connection Schematics for Multiple Circuit Breakers	52
11.4 Digitrip RMS Trip Unit Warranty	61	10-3 Connection Schematics for Multiple Circuit Breakers	53
		10-4 Digitrip Trip Unit Display Panel	55
		10-5 Terminating Resistor Location	56
		10-6 Terminating Resistor Location	56
		10-7 Terminating Resistor Location	57

10-8 Typical ATR 120 VAC Source Input and Dry Contact Alarm Output Connections for Remote Alarm Indication 58

10-9 Typical Control Schematic Without CC1 / CC2 Modification 59

10-10 Typical Control Schematic Without CC1 / CC2 Modification 59

10-11 CC1 / CC2 Modification to a Typical Control Schematic (Stored Energy) 59

10-12 CC1 / CC2 Modification to a Typical Control Schematic (Solenoid) 59

12-1 Without Ground 3Ø 3-Wire (LI, LS, LSI) 64

12-2 With Ground, Without Neutral Connection 3Ø 3-Wire (LIG, LSG, LSIG) 64

12-3 With Ground and With Neutral Sensor 3Ø 4-Wire (LIG, LSG, LSIG) 65

12-4 With Ground, With External Ground Source 3Ø 3-Wire or 4-Wire (LIG, LSG, LSGI) 65

12-5 Auxiliary CT Harness 66

12-6 Auxiliary CT Module Wiring 66

12-7 Digitrip RMS 510 Basic External Harness 67

12-8 Digitrip RMS 510 External Harness 67

12-9 Digitrip RMS 610 External Harness 67

12-10 Digitrip RMS 810 & 910 External Harness with CPT Adapter Harness 68

12-11 Digitrip RMS 810 & 910 External Harness 68

12-12 Digitrip RMS 510 Cell Harness 69

12-13 Digitrip RMS 610 Cell Harness 69

12-14 Digitrip RMS 810 & 910 Cell Harness 70

12-15 Digitrip RMS 810 & 910 Simplified Cell Harness 71

12-16 Digitrip RMS 810 & 910 PT Module 71

14-1 Time-Current Curves 76

Tables

2-1 Digitrip Rating Plugs (50 and 60 Hz) and Their Coordination with Sensor Connections 9

2-2 Digitrip RMS Retrofit Kit Accessories 10

8-1 Primary Injection Testing Settings and Expected Test Results 36

8-2 Self-Testing of the Digitrip Trip Unit Settings and Expected Test Results 40

8-3 DS Breaker Secondary Injection Testing Settings and Expected Test Results 44

9-1 Information Available to Operator While Breaker is in Service 48

9-2 Information Available in the Event of a Trip 49

12-1 Power Flow Conventions 63

NOTES

www.ElectricalPartManuals.com

SECTION 1 GENERAL INFORMATION AND SAFETY PRECAUTIONS

1.1 Safety Precautions

The warnings included as part of the procedural steps in this manual are for personnel safety and protection of the equipment from damage. An example of a typical warning is shown here to familiarize personnel with the style of presentation. In addition, the following warning applies throughout this manual. It should be read and understood before proceeding.



WARNING

POWER CIRCUIT BREAKERS ARE EQUIPPED WITH HIGH SPEED, HIGH ENERGY OPERATING MECHANISMS. THE BREAKERS AND THEIR ENCLOSURES ARE DESIGNED WITH SEVERAL BUILT-IN INTERLOCKS AND SAFETY FEATURES INTENDED TO PROVIDE SAFE AND PROPER OPERATING SEQUENCES. TO PROVIDE MAXIMUM PROTECTION FOR PERSONNEL ASSOCIATED WITH THE INSTALLATION, OPERATION, AND MAINTENANCE OF THESE BREAKERS, THE FOLLOWING PRACTICES MUST BE FOLLOWED. FAILURE TO FOLLOW THESE PRACTICES MAY RESULT IN DEATH, PERSONAL INJURY, OR PROPERTY DAMAGE.

- Only qualified persons, as defined in the National Electric Code, who are familiar with the installation and maintenance of Power Circuit Breakers and their associated switchgear assemblies should perform any work associated with these Breakers.
- Completely read and understand all instructions before attempting any installation, operation, maintenance, or modification of these Breakers.
- Always turn off and lock out the power source feeding the Breaker prior to attempting any installation, maintenance, or modification of the Breaker. Do not use the Circuit Breaker as the sole means for isolating a high voltage circuit. Follow all lockout and tagging rules of the National Electric Code and all other applicable codes, regulations, and work rules.

- Do not work on a closed Breaker or a Breaker with the closing springs charged. Trip (open) the Breaker and be sure the stored energy springs are discharged before performing any work. The Breaker may trip (open) or the charging springs may discharge, causing crushing or cutting injuries.
- For drawout Breakers, trip (open) and then remove the Breaker to a well-lit work area before beginning work.
- Do not perform any maintenance: including Breaker charging, closing, tripping, or any other function which could cause significant movement of the Breaker while it is on the extension rails. Doing so may cause the Breaker to slip from the rails and fall, potentially causing severe personal injury to those in the vicinity.
- **Do not leave the breaker in an intermediate position in the Switchgear Cell. Always leave it in the connected, disconnected, or (optional) test position. Failure to do so could lead to improper positioning of the breaker and flashover, causing death, serious personal injury, and / or property damage.**
- **Do not defeat any safety interlock. Such interlocks are intended to protect personnel and equipment from damage due to flashover and exposed contacts. Defeating an interlock could lead to death, severe personal injury, and / or property damage.**

1.2 Introduction

This Application Data is provided as a guide, for authorized and qualified personnel only, in the selection and application of Digitrip RMS Retrofit Kits on Power Circuit Breakers.

The information, recommendations, descriptions, and safety notations in this document are based on Cutler-Hammer's experience and judgement with respect to retrofitting Power Circuit Breakers. All possible contingencies which may arise during installation, operation, or maintenance, and all details and variations of this equipment do not purport to be covered by this document. If further information is desired by the purchaser regarding a particular installation, operation, or maintenance of his particular equipment, contact your local Cutler-Hammer representative or phone 1-800-937-5487.

1.3 Warranty Disclaimer and Liability Limitation

The instructions for installation, testing, maintenance, or repair herein are provided for the use of the product in general commercial applications and may not be appropriate for use in nuclear applications. Additional instructions may be available upon specific request to replace, amend, or supplement these instructions to qualify them for use with the product in safety related applications in a nuclear facility.

The information, recommendations, descriptions, and safety notations in this document are based on Cutler-Hammer's experience and judgement with respect to retrofitting of Power Circuit Breakers. This information should not be considered to be all inclusive or covering all contingencies. If further information is required, Cutler-Hammer should be consulted.

NO WARRANTIES, EXPRESSED OR IMPLIED, INCLUDING WARRANTIES OF FITNESS FOR A PARTICULAR PURPOSE OR MERCHANTABILITY, OR WARRANTIES ARISING FROM COURSE OF DEALING OR USAGE OF TRADE, ARE MADE REGARDING THE INFORMATION, RECOMMENDATIONS, AND DESCRIPTIONS CONTAINED HEREIN. In

no event will Cutler-Hammer be responsible to the user in contract, in tort (including negligence), strict liability or otherwise, for any special, indirect, incidental, or consequential damage or loss whatsoever, including but not limited to damage to or loss of use of equipment, plant or power system, cost of capital, loss of profits or revenues, cost of replacement power, additional expenses in the use of existing power facilities, or claims against the user by its customers resulting from the use of the information, recommendations, and descriptions contained herein.

SECTION 2 DIGITRIP RMS RETROFIT KITS, RATING PLUGS, AND ACCESSORIES

2.1 Digitrip RMS Retrofit Kits

Cutler-Hammer Digitrip RMS Retrofit Kits are available for many Breakers produced by major manufacturers of Power Circuit Breakers. The Digitrip RMS Retrofit Kits are structured according to the Digitrip RMS Trip Unit and the specific Overcurrent Protective features provided.

The product line begins with the Digitrip RMS 510 Basic Retrofit Kit series. True RMS sensing, basic Overcurrent Protection, and self-testing features are standard. The Overcurrent Protection provided is determined by the selected Long Time (L), Short Time (S), Instantaneous (I), and Ground Fault (G) Trip Functions.

The balance of the Retrofit Kits listed, Digitrip RMS 510, 610, 810, & 910 series, add increasing levels of features to those of the RMS 510 Basic Retrofit Kits and to each other. The features include Zone Interlocking, Digital Alphanumeric Displays, Remote Alarm Signals, PowerNet Communications, Energy Monitoring Capability, and Harmonic Distortion Information.

Additional information on the features and content of each Digitrip RMS Retrofit Kit is provided in Sections 4 through 7 of this Application Guide.

2.2 Retrofit Kit Installation Requirements

Digitrip RMS Retrofit Kits can be applied to many types of Power Circuit Breakers, provided the Breakers are used on 50 or 60 Hz AC distribution systems. Retrofits for fixed mounted or non-drawnout Breakers should be referred to Cutler-Hammer for evaluation.



WARNING

THE DESIGN AND CONTENT OF THE RETROFIT KIT IS BASED ON THE FOLLOWING CONDITIONS, WHICH MUST BE ADDRESSED BY THE RETROFIT KIT PURCHASER, PRIOR TO INSTALLATION. FAILURE TO ADDRESS THESE CONDITIONS COULD RESULT IN FAILURE OF THE EQUIPMENT TO OPERATE PROPERLY, PERMANENT EQUIPMENT DAMAGE, AND IN SOME INSTANCES, PERSONAL INJURY OR DEATH.

- 1. The Breaker must be in good mechanical and electrical operating condition.** Breakers that are not in good operating condition must be repaired, reconditioned, or refurbished prior to being retrofitted. Refer to Section 11 for general guidelines on Breaker preventative maintenance.
- 2. Rating Plug selection.** One Rating Plug is normally provided, which does not exceed the Breaker's maximum continuous current frame rating. If an alternate Rating Plug is required for the Breaker being retrofitted, it can be ordered separately or as part of the kit. Table 2-1 provides a complete listing of all Rating Plugs. Rating Plugs must coordinate with the Breaker Sensor Tap being used. Together they determine the Breaker Continuous Current Rating (I_n). Refer to Catalog 26-000 and the Digitrip Retrofit Kit Product Guide for Retrofit Kit ordering information.

3. **Retrofit Kits shown with Ground Fault (G) Protection assume a 3-phase, 3-wire grounded system.** If the retrofit is for a 4-wire grounded system, the customer must specify the fourth sensor when ordering the kit. Also, provisions must be made on the Breaker to bring the fourth sensor wiring through the Breaker secondary contacts. Secondary contacts and brackets, etc. are not included in the content of the kits.
4. **Digitrip RMS 610, 810, & 910 Retrofit Kits require an external (customer supplied) 120 VAC source** to power the Trip Unit information functions and Alphanumeric Digital Displays, as applicable. If the Optional Breaker Mounted Control Power Transformer (CPT) is utilized, the External 120 VAC power source via the Cell Harness assembly is not utilized for this condition.

2.3 The Retrofit Process

During the Retrofit process, the Retrofitter must adhere to the following guidelines to insure that the Breaker is in good working condition, that the Retrofit is performed correctly, and that the Breaker is ready to return to service.

1. It is the responsibility of the Retrofitter to insure that the Breaker and all original components are in good condition by visually inspecting each component for signs of damage or wear. If any signs of damage or wear are detected for components not included in the Retrofit Kit, the Retrofitter must secure the necessary replacement parts before beginning the Retrofit process.
2. It is the responsibility of the Retrofitter to carefully follow all instructions supplied with the Retrofit kit.
3. It is the responsibility of the Retrofitter to insure that the Direct Trip Actuator (DTA) Assembly has been correctly set-up, according to the specifications given within the instructions supplied with the Retrofit Kit.
4. It is the responsibility of the Retrofitter to insure that, following the Retrofit process, the force necessary to trip the Breaker meets the specifications given within the instructions supplied with the Retrofit Kit.
5. It is the responsibility of the Retrofitter to test the Retrofitted Breaker using primary injection. Refer to Section 8 of this manual for detailed testing procedures and specifications. For test information specific to the Trip Unit, refer to the IL publication supplied with the Retrofit Kit.
6. It is the responsibility of the Retrofitter to mount the Cell Harness in the cell in a location suitable for connection with the External Harness.
7. It is the responsibility of the Retrofitter to install the retrofitted Breaker in the Cell to insure proper Breaker / Cell fit and correct Breaker operation.

2.4 Digitrip RMS Retrofit Kit Accessories

Table 2-2 provides a listing of optional accessories that are useful in the installation, maintenance, and operation of your Breaker equipped with a Digitrip RMS Retrofit Kit.

Table 2-1 Digitrip Rating Plugs (50 and 60 Hz) and Their Coordination with Sensor Connections

<i>Sensor Rating</i>	<i>50/60 Hz Rating Plug Catalog Number & I_n Rating</i>		<i>Sensor Rating</i>	<i>50/60 Hz Rating Plug Catalog Number & I_n Rating</i>	
200:5	RP6A02A010	100 Amp	1600:5	RP6A16A080	800 Amp
	RP6A02A020	200 Amp		RP6A16A100	1000 Amp
300:5	RP6A03A020	200 Amp		RP6A16A120	1200 Amp
	RP6A03A025	250 Amp		RP6A16A160	1600 Amp
	RP6A03A030	300 Amp	2000:5	RP6A20A100	1000 Amp
400:5	RP6A04A020	200 Amp		RP6A20A120	1200 Amp
	RP6A04A025	250 Amp		RP6A20A160	1600 Amp
	RP6A04A030	300 Amp		RP6A20A200	2000 Amp
	RP6A04A040	400 Amp	3000:5	RP6A30A160	1600 Amp
600:5	RP6A06A030	300 Amp		RP6A30A200	2000 Amp
	RP6A06A040	400 Amp		RP6A30A250	2500 Amp
	RP6A06A060	600 Amp		RP6A30A300	3000 Amp
800:5	RP6A08A040	400 Amp	3200:5	RP6A32A160	1600 Amp
	RP6A08A060	600 Amp		RP6A32A200	2000 Amp
	RP6A08A080	800 Amp		RP6A32A240	2400 Amp
1200:5	RP6A12A060 RP6A12A080 RP6A12A100 RP6A12A120	600 Amp		4000:5	RP6A32A320
		800 Amp	RP6A40A200		2000 Amp
		1000 Amp	RP6A40A250		2500 Amp
		1200 Amp	RP6A40A300		3000 Amp
				RP6A40A320	3200 Amp
				RP6A40A400	4000 Amp

Notes:

1. Sensor Tap rating connected must correspond with the Rating Plug shown.
2. Breaker current rating shown is adjustable down to 50% of the value listed with Digitrip RMS Long Delay Pickup Setting.
3. Rating Plugs for Digitrip 510, 610, 810, & 910 are NOT interchangeable with Rating Plugs for Digitrip 500, 600, 700, or 800.
4. A complete listing of all Rating Plugs (Retrofit, DS and SPB) is in the Cat 26-000, Second Edition, March 1997.

Table 2-2 Digitrip RMS Retrofit Kit Accessories

<i>Accessory Description</i>	<i>Accessory Style or Catalog Number</i>	<i>Function</i>
Auxiliary Power Module (APM)	PRTAAPM	Powers Digitrip RMS Trip Unit for testing.
Secondary Injection Test Kit	8779C02G02	Tests Digitrip RMS Trip Unit by Secondary Injection. Requires Adapter Harness.
Adapter Harnesses*	6503C53G01 (Type1) or 6503C54G01 (Type 2) and 6503C55G01 (Breaker Mounted Test Plug)	Connects Secondary Injection Test Set to Trip System for testing.
External Harness (For 510 Basic Kit)	6502C83G01	Plugs into RMS Trip Unit Plug J2. Shorts Out G_{IN} to G_{OUT} and S_{IN} to S_{OUT} during Trip Unit testing.
Lithium Battery 3.0 Volt NOTE: Sourced from the listed suppliers.	Type CR 1/3N Varta Batteries, Inc., 150 Clarbrook Road, Elmsford, NY 10523 Type DL 1/3N Duracell, South Broadway, Tarrytown, NY 10591 (914)591-7000 Type CR 1/3N Sanyo Electric, Inc., Battery Division 200 Riser Road Little Ferry, NJ 07643	Powers Digitrip LED Trip Indicators (Back-up Power).
Cell Harness Assembly	6503C57G03	Provides auxiliary power and shorts out the Zone Interlocks during testing, for all 610, 810, & 910 Kits with an External Harness.

*See Section 8.7

SECTION 3 THE DIGITRIP RMS TRIP SYSTEM

3.1 Digitrip RMS Overcurrent Protection

The Digitrip RMS Retrofit Kits covered by this Application Guide are designed to replace the existing Trip System employed on the Breaker selected for Retrofitting.

All Digitrip RMS Retrofit Kits provide basic Overcurrent Protection, which includes a selected combination of Long Time (L), Short Time (S), Instantaneous (I), and Ground Fault Time (G) Delay Trip Functions. Five major components comprise the Digitrip RMS Trip System: the Current Sensors; Auxiliary CT Module; Digitrip Trip Unit; Rating Plug; and the Direct Trip Actuator (DTA). These components are interconnected by use of the various wiring harnesses to make up the Digitrip RMS Trip System. Breaker interface diagrams for Digitrip RMS 510 through 910 are provided in Sections 4 through 7. These diagrams show the major Digitrip RMS components and their interconnections. Wiring diagrams for each of the wiring harnesses are shown in Section 12.

Figure 3-1 shows the major components of the Digitrip Retrofit System and their interconnections. The following sections describe the function and operation of each component.

3.2 Current Sensors and Sensor Wiring Harness

Three single or multi-tapped Current Sensors (one per phase) are located at the rear of the Breaker. The Sensors pass information to the Auxiliary CT Module and the Trip Unit about the primary current level passing through the Breaker. All the energy required to power the Digitrip RMS Trip System is produced by the Current Sensors.

The Current Sensors are connected to a terminal block strip on the Auxiliary CT Module by the Sensor Wiring Harness. The Current Sensor Tap ratio connected, in concert with the Rating Plug, determines the Continuous Current Rating (In) of the Breaker. At rated primary current, the Current Sensors provide 5 ampere nominal current inputs to the Auxiliary CT Module.

3.3 Auxiliary CT Module and Auxiliary CT Harness

The Auxiliary CT Module encloses three auxiliary phase Current Transformers, which reduce the 5 ampere nominal inputs from the Current Sensors to the milliampere level required for the Digitrip RMS Trip Unit electronics. When Ground Fault (G) protection is selected, a Ground Auxiliary Current Transformer is also provided, which performs the same function.

A 7-point terminal block strip is mounted to the Auxiliary CT Module. Terminals A through G terminate the inputs from the Current Sensors via the Sensor Wiring Harness. Terminals OP and ON connect the Trip Signal Outputs to the Direct Trip Actuator (DTA) via the Sensor Wiring Harness or DTA Wiring Harness. A 12-point female CT Plug-in Block is mounted on the right hand side of the module, which receives the male plug of the Auxiliary CT Harness. The Auxiliary CT Harness also has a 10-pin black plug, which plugs into the Trip Unit to connect the Auxiliary CT Inputs to the Trip Unit and receives the Trip Unit trip signal outputs. Refer to Figure 12-6 for Auxiliary CT Module wiring.

3.4 Digitrip RMS Trip Unit and Power Relay Module (ATR)

The 10-Series Digitrip RMS Trip Units (510 through 910 Kits), Figure 3-1, are designed to permit flexibility in Retrofit applications. They are physically repackaged versions of the original 100-Series Digitrip RMS Trip Units that were used on Cutler-Hammer DS and SPB Breakers. The RMS Trip Units have the same features and options and have identical characteristic curves, adjustments, and electrical performance.

The Digitrip RMS Trip Unit is a microprocessor based protective device that provides true RMS sensing means for proper correlation with thermal characteristics on conductors and equipment. Digitrip RMS Trip Units are available in four models, RMS 510, 610, 810, & 910. These models are available in horizontal or vertical labeling and display orientations.

The Trip Unit includes a female type receptacle provided to accept a Rating Plug, which, in concert with the Current Sensors, determines the Continuous Current Rating (In) of the Breaker or the Long Delay (Ir) Setting of the Breaker. Adjustable current protective settings are provided for the Long Time (L), Short Time (S), Instantaneous (I), and Ground Fault (G) Trip Functions selected. Short Time (S) and Ground Fault (G) Delays are equipped with an adjustable setting for a flat or an I²t response. The adjustable settings are step-type, expressed in terms of Continuous Current Rating (In) the maximum of the Breaker or the Long Delay Setting (Ir) of the Breaker. LEDs provide Mode of Trip Indications for the L, S, I, and G trip functions. Digitrip RMS Trip Units are equipped with multi-pin disconnect plug receptacles which permit quick connections to the Auxiliary CT Harness and, when supplied, the External Harness.

The Power Relay Module (ATR) is provided in Digitrip RMS Trip Unit Kits 610 through 910 only. The ATR provides hard contact closures for remote indication of the following Trip Unit functions:

- High Load (HL) Alarm
The HL contact closes when the current passing through the Breaker exceeds 85% of the Trip Unit Long Delay Pickup Setting continuously for more than 40 seconds.
- Long Delay (LD) Trip
- Short Circuit (SC) Trip
- Ground Fault (GF) Trip
- PowerNet Remote Close (CC1 and CC2) Contact (RMS 810 & 910 Trip Units only)

All ATR contacts are rated 1 ampere at 120 VAC or 1 ampere at 28 VDC. These contacts are generally used for illuminating indicator lights or picking up slave relays local to or remote from the Breaker / Switchgear. A bridge rectifier circuit in the ATR serves to power up the Trip Unit, the Trip Unit Alphanumeric Display, and the INCOM Communications, when a 120 VAC source is supplied to ATR terminals AC120 and ACCOM.

Digitrip RMS Trip Units are equipped with a receptacle, located on the front of the Trip Unit, to receive the Auxiliary Power Module (APM). The APM is used to supply power to the Trip Unit self-test system during Circuit Breaker testing. Adjustable test settings are provided which enable the unit to be tested with or without tripping the Breaker.

Figures 3-2 through 3-4a & 3-4b provide the published Digitrip RMS Characteristics Curves for Retrofit Breakers. Also provided are the available Trip Unit settings for all trip functions. These curves are available on onion paper as Applications Data 32-870.

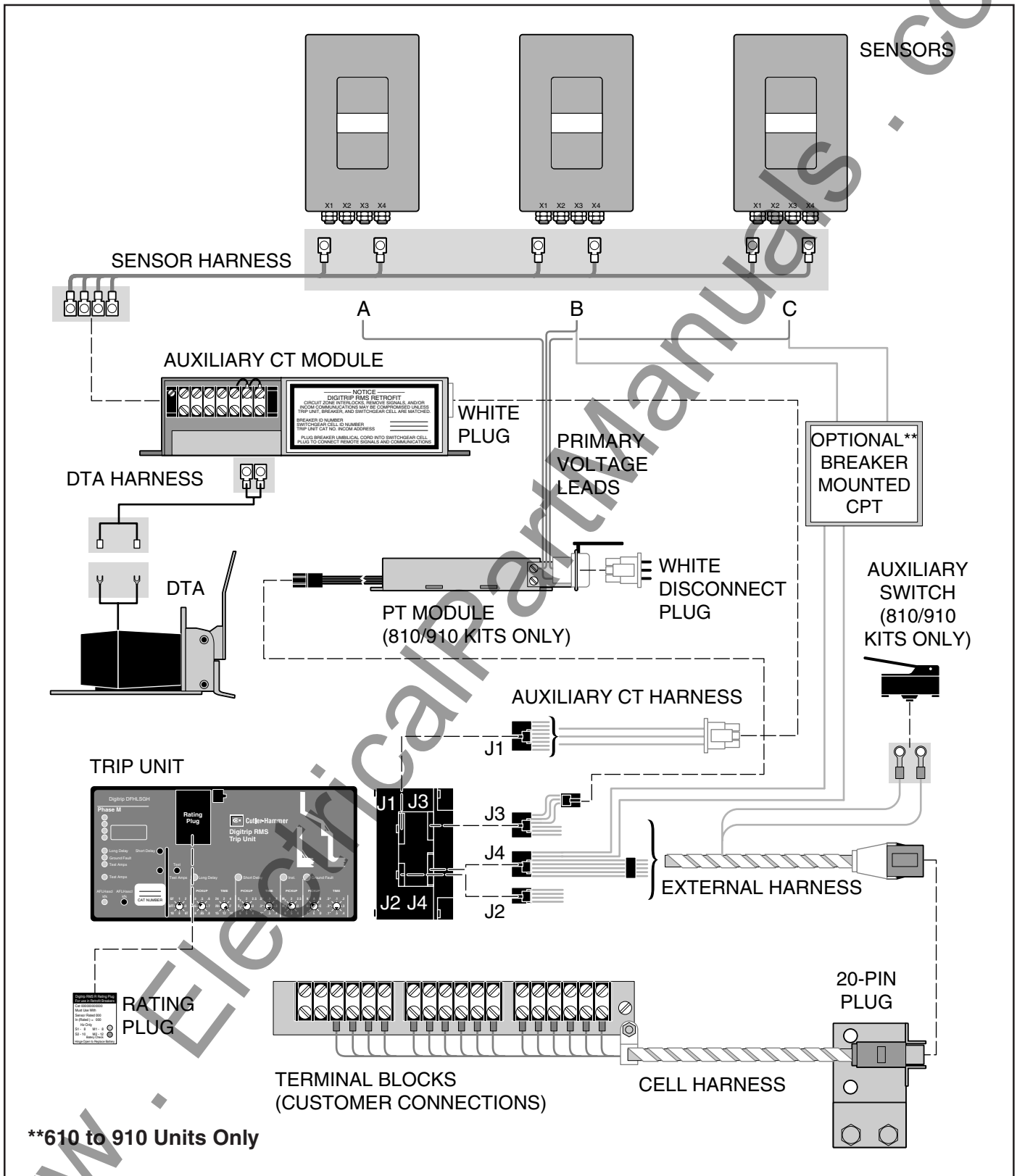

****610 to 910 Units Only**

Fig. 3-1 Digitrip Retrofit System

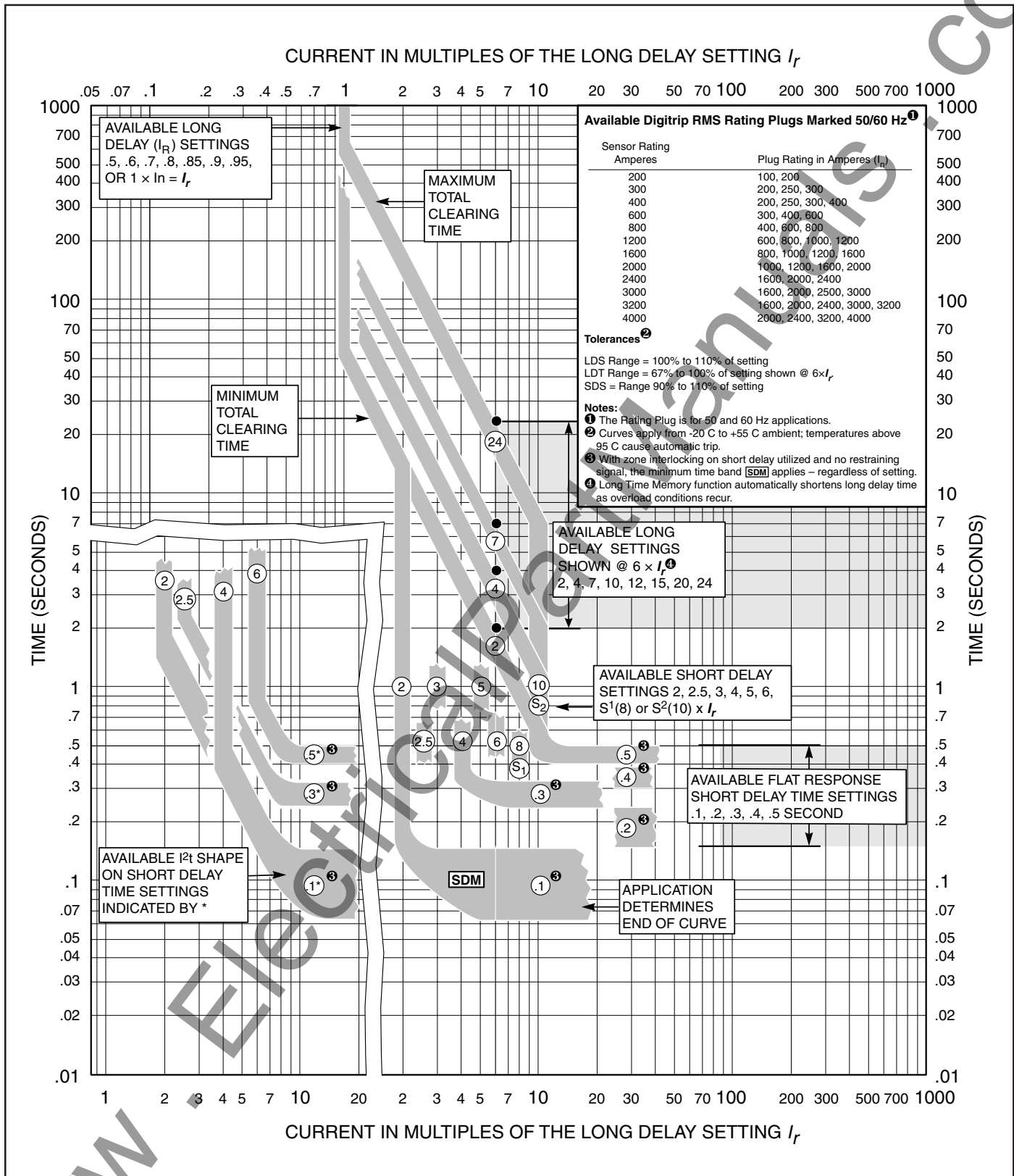

Fig. 3-2 Digitrip RMS Long Time / Short Time-Current Curves

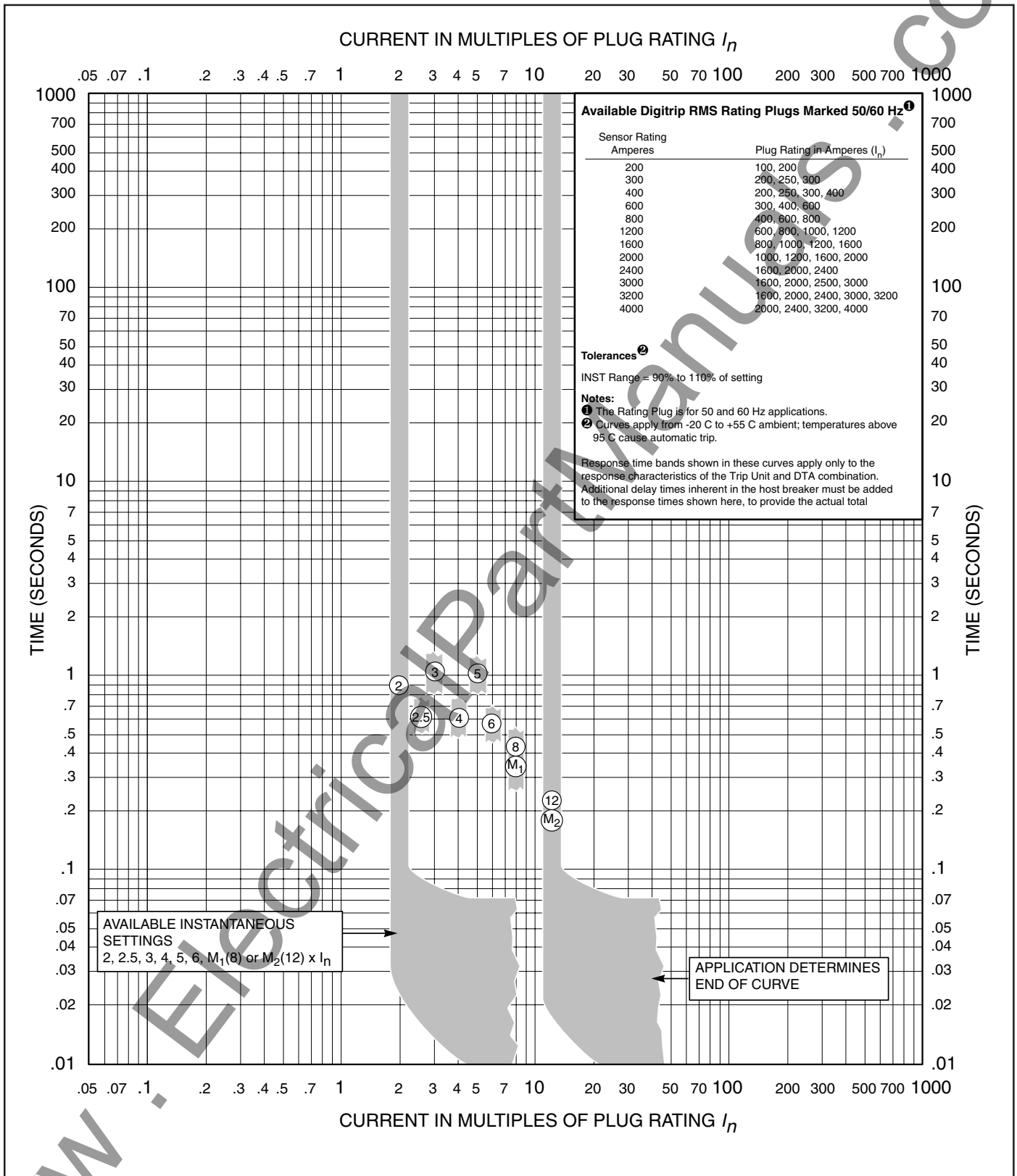

Fig. 3-3 Digitrip RMS Instantaneous Time-Current Curve (I)

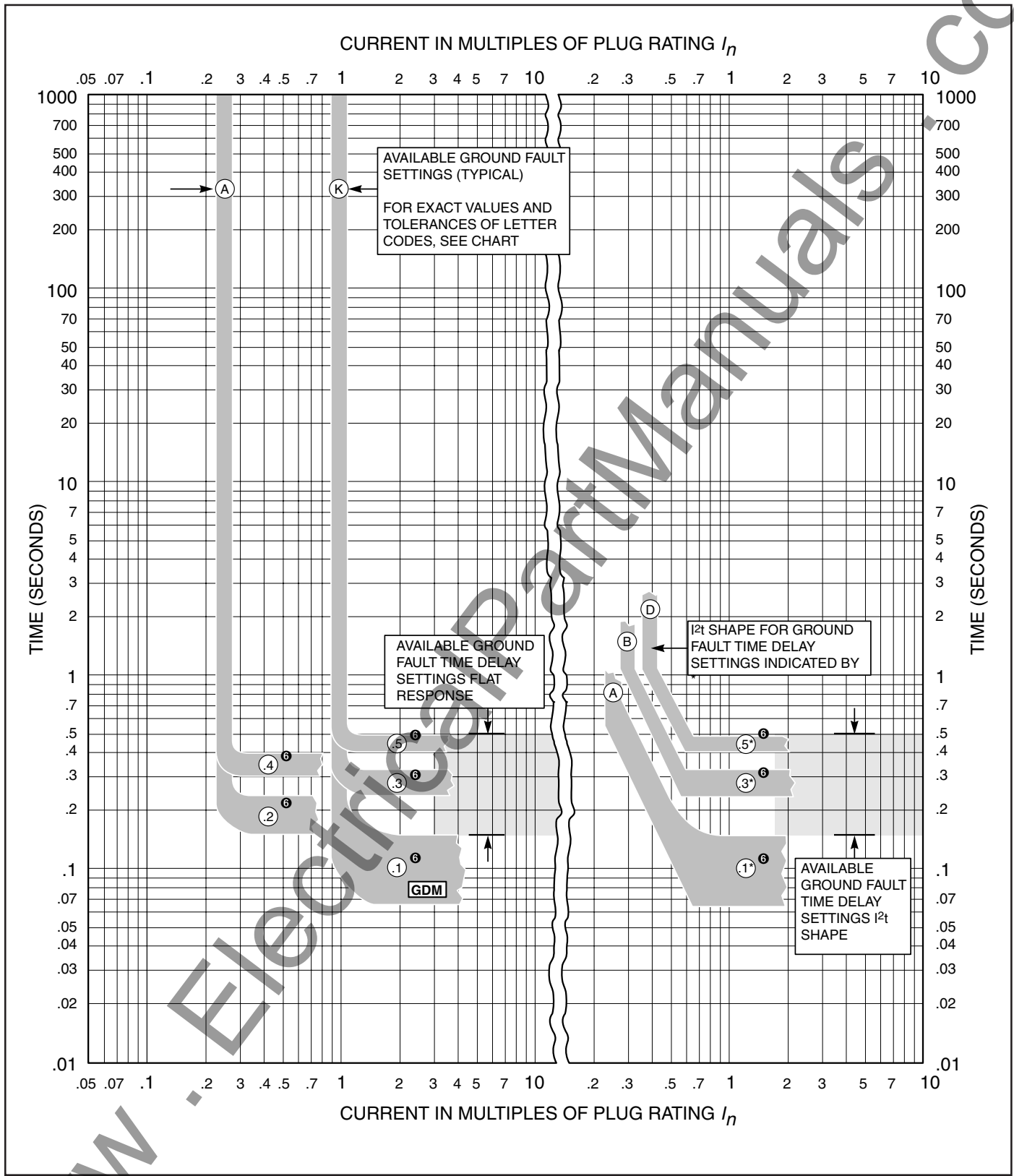

Fig. 3-4a Digitrip RMS Ground Fault Protection Time-Current Curve (G)

3.5 Long Time Memory Function

In addition to the standard Long Delay Protection Element, Digitrip RMS 510, 610, 810, & 910 Trip Units also have an unpowered Long Time Memory function (LTM), which serves to protect load circuits from the effects of repeated overload conditions. If a Breaker is reclosed soon after a Long Delay Trip and the current again exceeds the Long Delay Setting (I_r), the LTM automatically reduces the time to trip to allow for the fact that the Load Circuit temperature is already higher than normal, due to the prior overload condition. Each time an overload condition is repeated, the LTM causes the Breaker to trip in a time progressively earlier than the “Long Delay Time Settings”. When the Load Current returns to normal, the LTM begins to reset; and after about 10 minutes it has reset fully. Therefore the next Long Delay Trip Time will again be the “Setting” value.

In certain applications, it may be desirable to disable the LTM function. The LTM function can be disabled by first removing the Rating Plug from the Trip Unit (Figure 3-5a), and then moving the LTM Jumper found inside the Rating Plug cavity on the Trip Unit (Figure 3.5b) to its “INACTIVE” connection (Figure 3.5c). You can enable the LTM function again at any time by moving the LTM Jumper back

to its original “ACTIVE” connection. The action of the LTM is a factor to consider in performing multiple Long Delay Time tests as described in Section 8 of this manual.

3.6 Discriminator (High Initial Current Release)

When the Digitrip RMS Trip Unit is not equipped with an adjustable instantaneous protection setting, i.e.: types LS or LSG, a Discriminator Circuit is provided. This circuit will prevent the Circuit Breaker from being closed and latched-in on a faulted circuit. The nonadjustable release is preset at eleven (11) times the installed Rating Plug ampere rating (I_n).

The Discriminator is armed only for the first ten (10) cycles following an initial Circuit Breaker closing operation with a load current exceeding approximately 20% of the Circuit Breaker Frame or Sensor Rating. Should the Load Current through the Circuit Breaker drop to a value less than this, the Discriminator will re-arm. Once armed, it will remain armed until the Load Current passing through the Circuit Breaker exceeds approximately 20% for 10 cycles. Any trip operation initiated by the Discriminator will trip the Circuit Breaker instantaneously. The Discriminator can be selected “on” or “off” by a switch selection on the front of the Trip Unit.

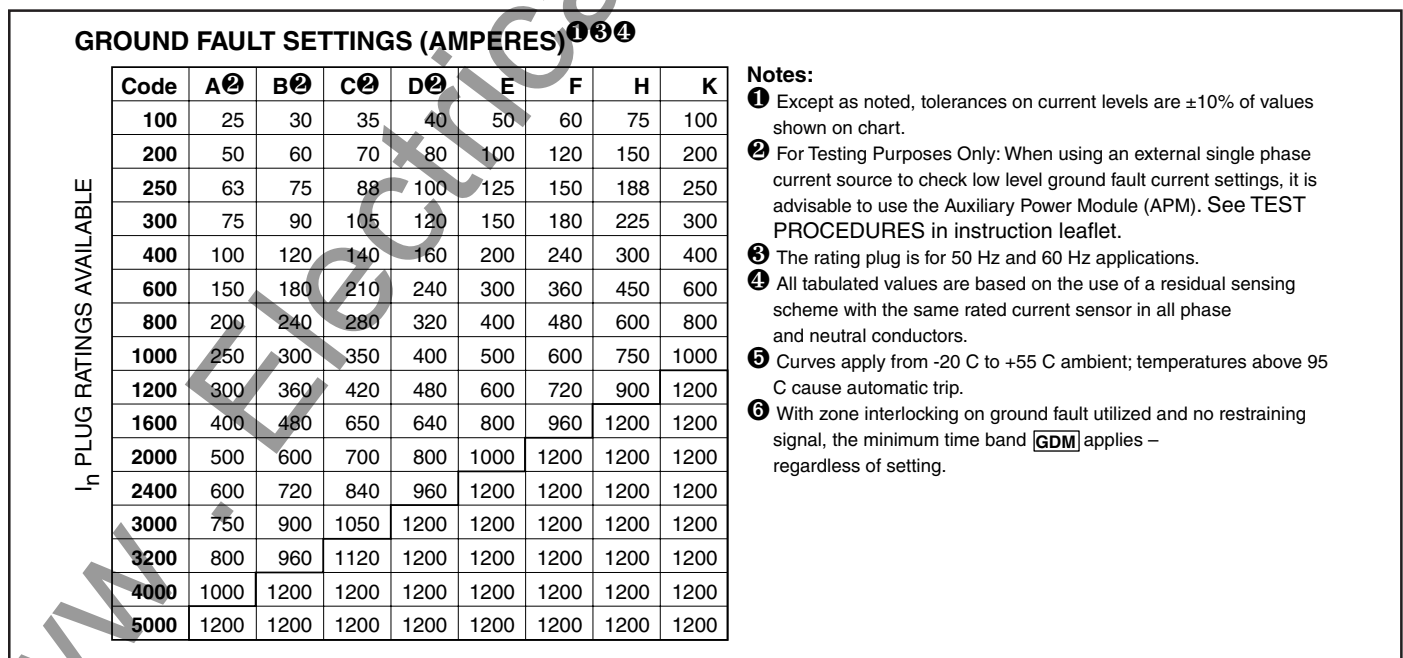

Fig. 3-4b Digitrip RMS Ground Fault Protection Time-Current Curve (G)

3.7 Digitrip RMS Direct Trip Actuator (DTA) and Auxiliary Switch Kit (See Figure 3-6)

The Digitrip RMS Direct Trip Actuator (DTA) receives an electrical trip pulse from the Trip Unit via the Auxiliary CT Module and provides the mechanical trip force to trip the Breaker.

The DTA is made up of a permanent magnet, a disc held by the magnet, a rod acted on by a spring, a means for tripping the Breaker, and a Reset Mechanism for mechanically resetting the DTA. The magnet cannot pull and reset the disc against the force of the spring acting on the rod, but it can overcome the spring force when the disc is in contact with the magnet pole piece.

A tripping pulse from the Trip Unit counteracts the effect of the permanent magnet, allowing the spring to separate the disc from the magnet pole piece and to actuate the DTA. The DTA strikes the Trip Paddle and trips the Breaker. As the Breaker opens, the Breaker Mechanism moves the DTA

Reset Mechanism, which moves the disc to close the air gap between it and the magnet pole piece. The DTA is reset when the disc is held in contact with the magnet pole piece, against the spring force. If the DTA does not reset properly, the DTA will hold the Breaker in the trip free condition and the Breaker will not be able to close.

For Powered Trip Units: Once an overcurrent has occurred, the Trip Unit sends an electrical signal to the DTA which will be monitored until the Trip Unit is reset, keeping the Breaker in a trip free condition.

RMS 810 & 910 Retrofit Kits include an Auxiliary Switch Kit, which usually mounts on or near the DTA. The Auxiliary Switch Kit consists of a microswitch with mounting hardware and brackets. The switch is used to provide the Trip Unit with information on the Breaker status, i.e.: open or closed. This status information is passed on through the PowerNet network.

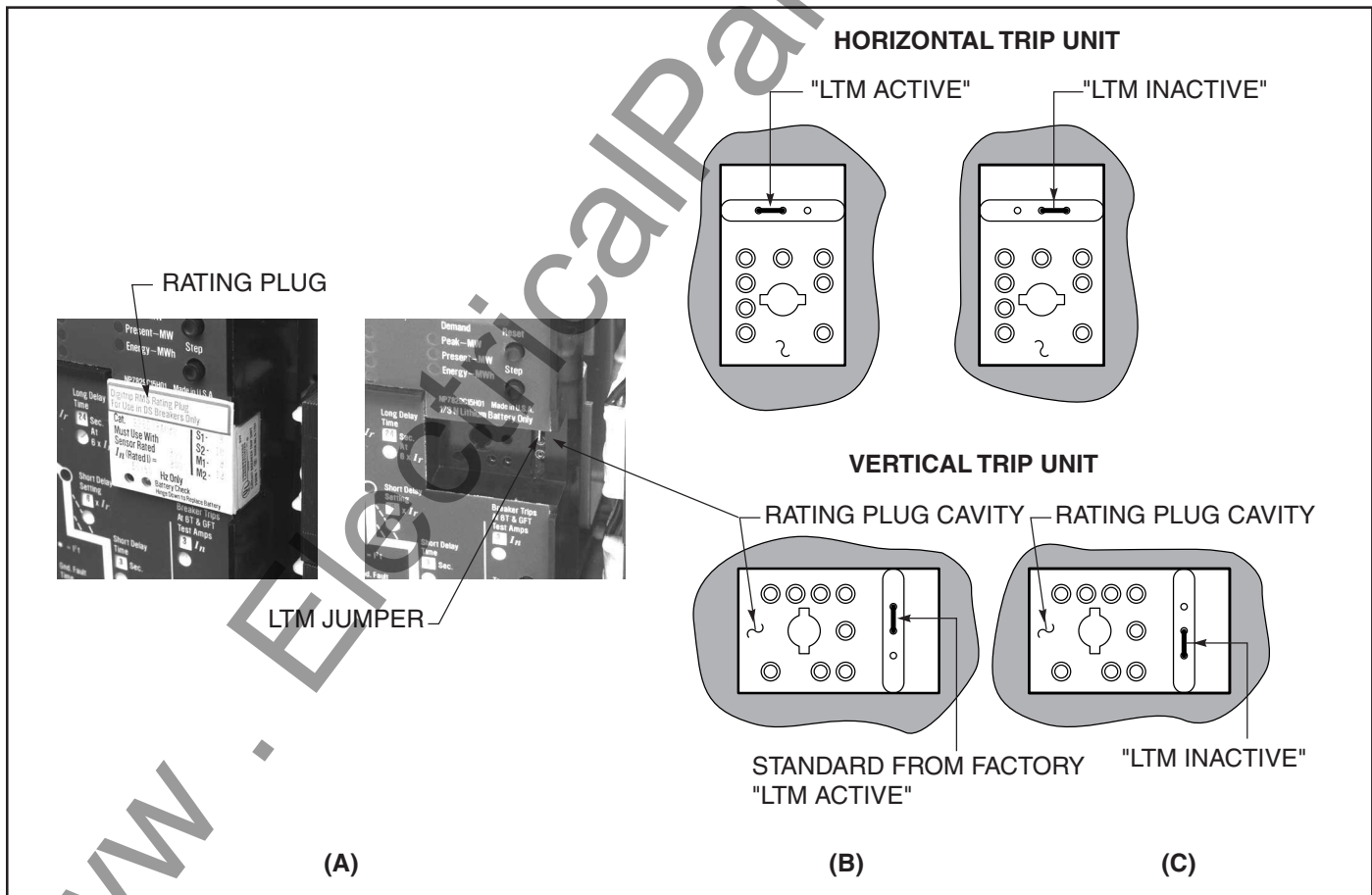

Fig. 3-5 Disabling the Long Time Memory (LTM) Function

3.8 Digitrip RMS Retrofit Rating Plug and Battery

The Digitrip RMS Rating Plug fits into the Digitrip RMS Trip Unit and determines the Breaker Continuous Current Rating, In. The Rating Plug must be matched to the installed Current Sensor ratio. The Rating Plug can be used in 50 Hz or 60 Hz applications. Each Rating Plug has fixed S1 (8) and S2 (10) values, which correspond to the Trip Unit's highest two Short Delay Settings. Each Rating Plug also has fixed M1 (8) and M2 (12) values, which correspond to the Trip Unit's highest two Instantaneous Settings.

Each Rating Plug is equipped with a long life, 3.0 Volt lithium type back-up battery. This back-up battery is not required for the basic Digitrip RMS Overcurrent Protective Functions. It is used to maintain the Trip Unit mode of trip indication LEDs, following a Breaker tripping operation, when no

120 VAC control power source (through the ATR) to the Trip Unit is applied. A new battery will maintain the mode of trip LED for approximately 60 hours when no 120 VAC source is applied to the Trip Unit. The battery is replaced from the front, without having to remove the Rating Plug from the Trip Unit. Replacement battery types are listed under the Accessories, Section 2, of this Application Guide.

SPB Rating Plugs are matched to the Breaker Frames which are suitable. The Rating Plug Attachment is accomplished by use of a specific Rating Plug screw size and length.

If a Rating Plug is removed when the Breaker is in the closed position, the Breaker may trip. Therefore, the Rating Plug must be securely plugged in and the Trip Cover put back on the Trip Unit to assure that the Rating Plug stays in place.

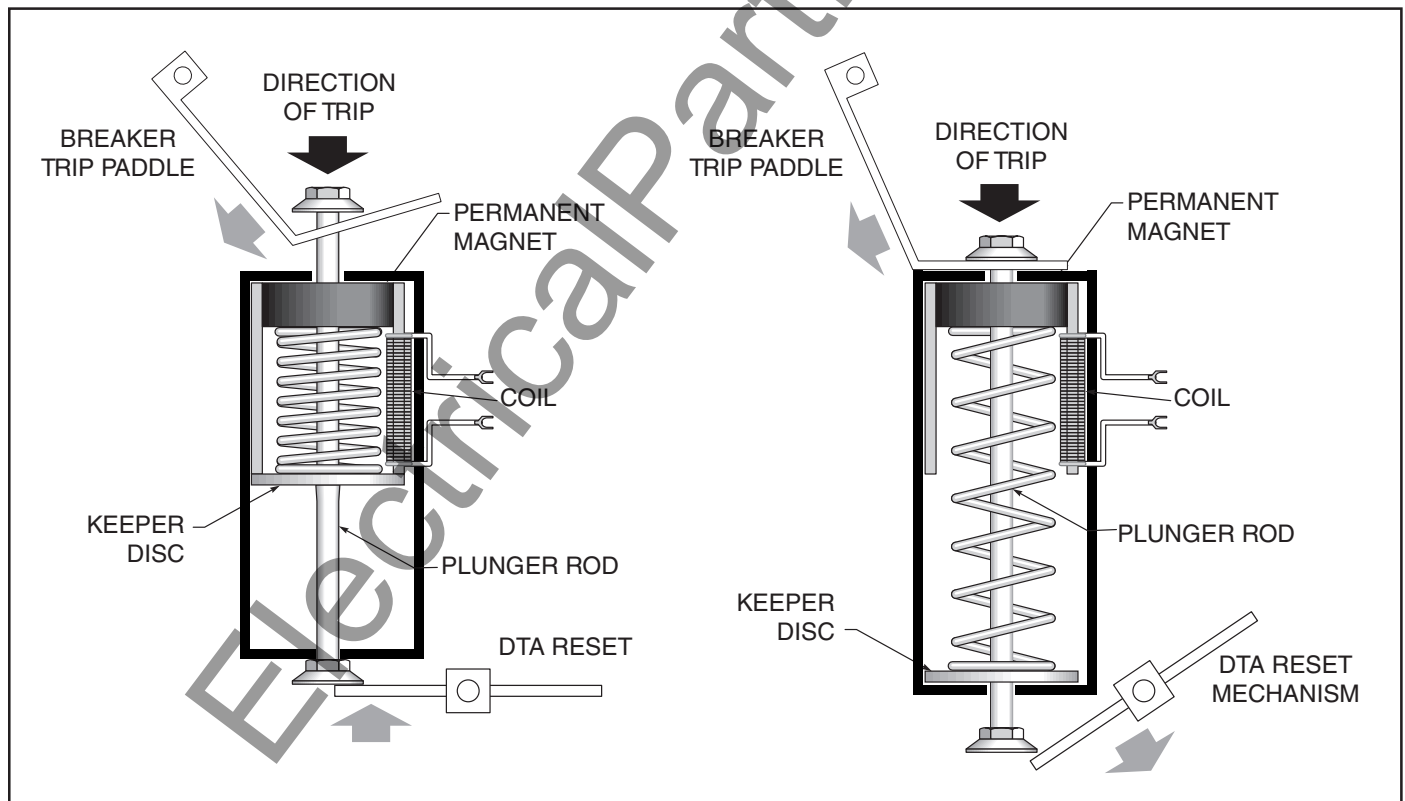

Fig. 3-6 Digitrip RMS Direct Trip Actuator (DTA)

3.9 External Harness

The External Harness is used to extract Zone Interlocking, Remote Alarm, and PowerNet communications signals, as applicable, from the Trip Unit and to connect the 120 VAC power required on RMS 610, 810, & 910 Kits. The External Harness also has a large 20-pin plug that plugs into the Cell Harness Assembly which is mounted in the Switchgear Cell. The External Harness provided with RMS 510 Basic Kits consists of just a small jumper plug that shorts out the Zone Interlock connections on the Trip Unit.

3.10 Potential Transformer (PT) Module

A Potential Transformer (PT) Module is supplied with each RMS 810 & 910 Kit. The PT Module passes on Circuit Breaker primary voltage information to the Trip Unit for use in obtaining PowerNet energy monitoring data. Three (3) 600 Volt leads are provided for the PT Module primary connection to the Breaker. These leads may be connected to either the Line Side or Load Side of the Breaker. The PT Module secondary terminates to a 4-pin female plug to permit connection to the Trip Unit.



CAUTION

THE PT MODULE PRIMARY DISCONNECT PLUG MUST BE DISCONNECTED WHEN DIELECTRIC TESTING OF THE BREAKER / SWITCHGEAR ASSEMBLY IS PERFORMED OR THE TRIP UNIT AND / OR THE PT MODULE MAY BE DAMAGED. DO NOT DISCONNECT THE PT MODULE PLUG WHEN THE BREAKER IS ENERGIZED OR IN THE CONNECTED POSITION. MOVE THE BREAKER TO THE TEST POSITION BEFORE PULLING THE PT MODULE PLUG.

3.11 Cell Harness Assembly

The Cell Harness Assembly is provided on all Retrofit Kits, except the RMS 510 Basic series and the 610 simplified kits with the Breaker Mounted Control Power Transformer (CPT). Its function is to extract the Zone Interlocking, Remote Alarm, and Communications Signals from the Breaker by connection to the External Wiring Harness, and provide terminations for external customer connections. Use of the Cell Harness Assembly reduces the time required for Retrofit. It eliminates the need to completely rewire the secondary contacts on the Circuit Breaker and in the Switchgear to accommodate the added Digitrip RMS signals.

The Cell Harness Assembly mounts in the Breaker compartment of the Switchgear. The Cell Plug receives the Breaker External Harness Plug, providing a disconnectable means of extracting the signals from the Breaker. A Wiring Harness brings the signal to terminal blocks for customer external connections in the Switchgear. Depending on the Retrofit Kit selected, up to three (3) terminal blocks (TB1, TB2, and TB3) are provided.

3.12 Breaker Mounted Control Power Transformer (CPT)

Digitrip RMS 610, 810, & 910 Retrofit Kits are available with an optional Breaker Mounted Control Power Transformer (CPT), which provides the 120 VAC input to the ATR by tapping the Line Side of the Breaker and transforming that voltage to 120 VAC. This option is widely used because it eliminates the need to run 120 VAC control power from cell to cell in the Switchgear.



CAUTION

ISOLATE THE BREAKER MOUNTED CPT WHEN DIELECTRIC TESTING OF BREAKER / SWITCHGEAR ASSEMBLY IS PERFORMED OR THE CPT MAY BE DAMAGED.

SECTION 4 DIGITRIP RMS 510 BASIC RETROFIT KITS (WITHOUT ZONE INTERLOCKS)

4.1 Digitrip RMS 510 Basic Retrofit Kit Selection and Content

The Digitrip RMS 510 Basic Retrofit Kit series provides basic Overcurrent Protection only. The Retrofit Kits are available with the applicable Digitrip RMS 510 Trip Unit Overcurrent Trip Functions, (i.e.: Long Time (L); Short Time (S); Instantaneous (I); and Ground Fault Time (G) Delays). The combinations available are LI, LS, LSI, LIG, LSG, LSIG.

The complete Digitrip RMS 510 Basic Retrofit Kit is mounted on the Breaker. Therefore, no Switchgear Cell modifications or wiring are required. Zone Interlocking signals from the Trip Unit are not wired out from the Breaker. The External Harness (Figure 12-7) consists of a small jumper plug that shorts out the Zone Interlock signals at the Trip Unit. Refer to Figure 4-1 for the Retrofit Kit wiring connections on the Breaker.

NOTE: Figure 4-1 applies to Retrofit Kits other than SPB and DS Retrofit Kits. Refer to the DS or SPB ILs or kit manual for specific wiring.

4.2 Digitrip RMS 510 Basic Retrofit Kit Features

The Digitrip RMS 510 Trip Unit has the following features available for customer use, when applied in the Digitrip RMS 510 Basic Retrofit Kit:

1. Basic (L, S, I, G) Overcurrent Protection, as selected;
2. True RMS Sensing;
3. Integral Trip Unit Testing;
4. Unit Status Indicator;
5. Local Mode of Trip Indicators; and
6. Selectable I^2t on Short Time and Ground Fault Time Delays when those options are selected.

The Trip Unit also includes provisions to accept the required Rating Plug. The Rating Plug is equipped with a battery to power the local mode of trip indicators.

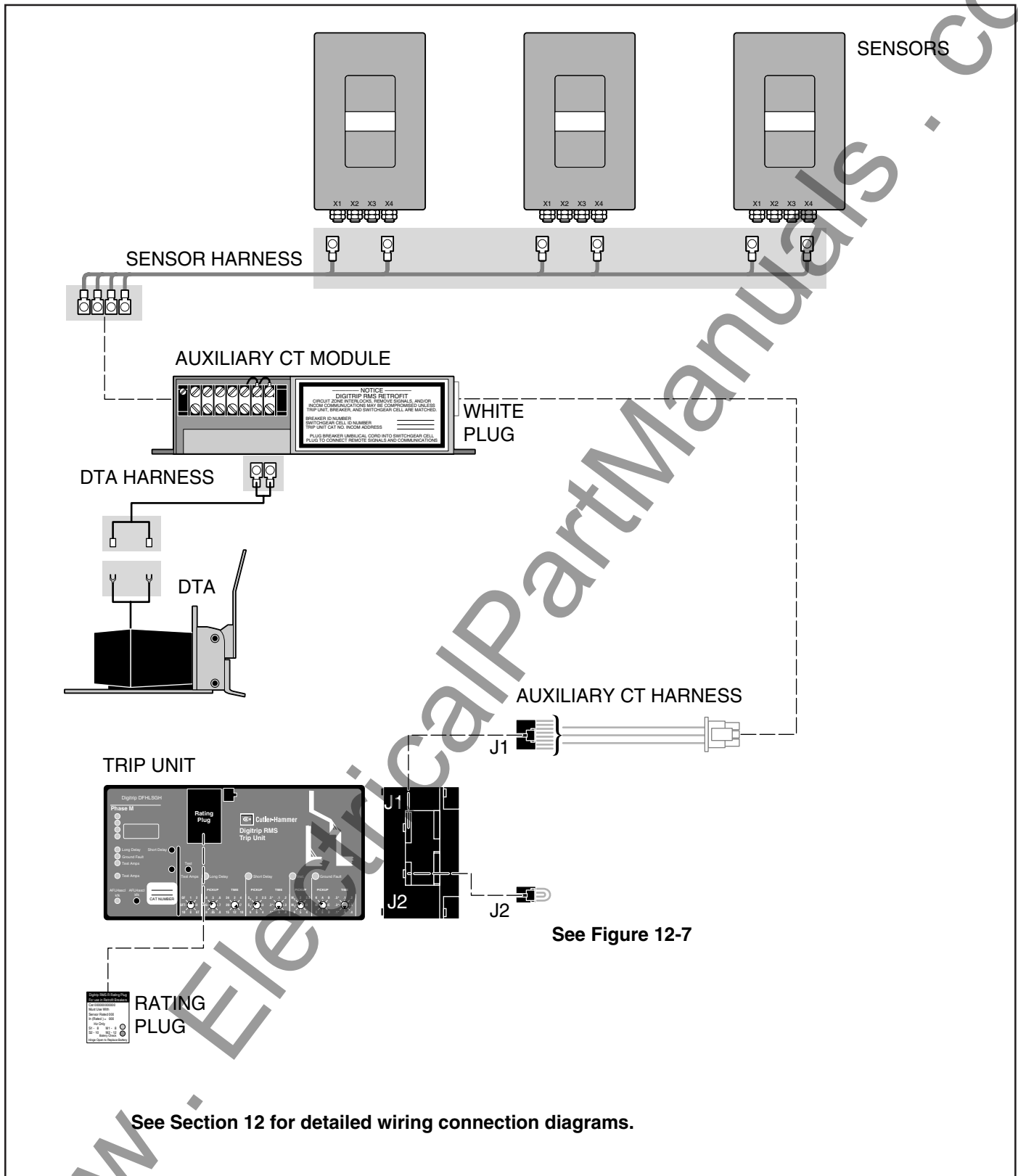

See Section 12 for detailed wiring connection diagrams.

Fig. 4-1 Digitrip RMS 510 Basic Wiring

SECTION 5 DIGITRIP RMS 510 RETROFIT KITS (WITH ZONE INTERLOCKS)

5.1 Digitrip RMS 510 Retrofit Kit (With Zone Interlocks) Selection and Content

The Digitrip RMS 510 Retrofit Kit series provides basic Overcurrent Protection plus Zone Interlock capability. The Retrofit Kits are available with the applicable Digitrip RMS 510 Trip Unit Overcurrent Trip Functions, (i.e.: Long Time (L), Short Time (S), Instantaneous (I), and Ground Fault Time (G) Delays). The combinations available are LI, LS, LSI, LIG, LSG, LSIG.

Zone Interlock signals are extracted from the Trip Unit by the External Harness. The External Harness includes a 20-pin plug, which connects to the Cell Harness Assembly. All Retrofit Kit components are mounted on the Breaker, except the Cell Harness Assembly, which is mounted in the Switchgear Cell. Figures 5-1, 12-8 and 12-12 provide the Retrofit Kit wiring connections on the Breaker and the Switchgear Cell.

5.2 Digitrip RMS 510 Retrofit Kit (With Zone Interlocks) Features

The Digitrip RMS 510 Trip Unit has the following features available for customer use, when applied in the Digitrip RMS 510 Basic Retrofit Kit with Zone Interlocks:

1. Basic (L,S,I,G) Overcurrent Protection, as selected.
2. True RMS Sensing;
3. Integral Trip Unit Testing;
4. Unit Status Indicator;
5. Local Mode of Trip Indicators;
6. Selectable I^2t on Short Time and Ground Fault Time Delays when those options are selected; and
7. Zone Interlock capabilities of the Breaker Short Time and Ground Fault Delay Functions, when those options are selected.

The Trip Unit also includes provisions to accept the required Rating Plug. The Rating Plug is equipped with a battery to power the local mode of trip indicators.

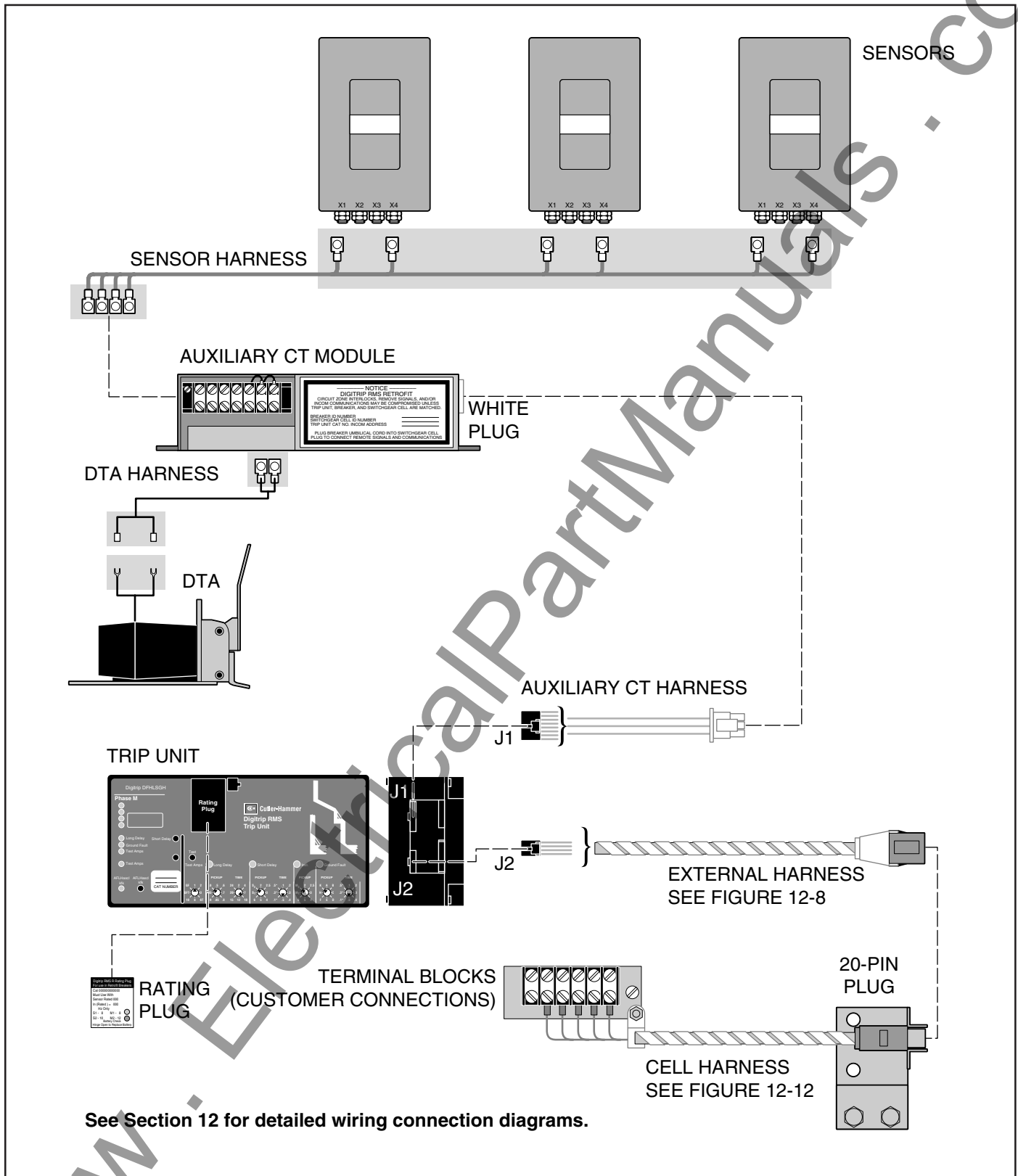

See Section 12 for detailed wiring connection diagrams.

Fig. 5-1 Digitrip RMS 510 Wiring

SECTION 6 DIGITRIP RMS 610 RETROFIT KITS

6.1 Digitrip RMS 610 Retrofit Kit Selection and Content

The Digitrip RMS 610 Retrofit Kit series provides Overcurrent protection, Zone Interlock capability, and a local Alphanumeric Display. The Retrofit Kits are available with the applicable Digitrip RMS 610 Trip Unit Overcurrent Trip Functions, (i.e.: Long Time (L), Short Time (S), Instantaneous (I), & Ground Fault Time (G) Delays). The combinations available are LI, LS, LSI, LIG, LSG, LSIG.

In addition to Zone Interlocks, the RMS 610 Trip Units include the Power Relay Module (ATR) which provides contact closures for remote indication and alarm. Zone Interlocking and remote alarm signals are extracted from the Trip Unit by the External Harness. The External Harness includes a 20-pin plug, which connects to the Cell Harness Assembly.

A 120 VAC control power source is required to power up the Power Relay Module (ATR) remote signals, the local mode of trip indicators, and the Trip Unit Alphanumeric Digital Display. Figures 6-1, 12-9, and 12-13 provide the Retrofit Kit wiring connections on the Breaker and in the Switchgear Cell. All Retrofit Kit components are mounted on the Breaker, except the Cell Harness Assembly, which is mounted in the Switchgear Cell.

The 120 VAC control power can be supplied externally via wiring in the Cell or it can be supplied via the Breaker Mounted Control Power Transformer (CPT) (optional with the Retrofit Kit).

6.2 Digitrip RMS 610 Retrofit Kit Features

The Digitrip RMS 610 Trip Unit has the following features available for customer use, when applied in the Digitrip RMS 610 Retrofit Kit:

1. Basic (L,S,I,G) Overcurrent Protection, as selected;
2. True RMS Sensing;
3. Integral Trip Unit Testing;
4. Unit Status Indicator;
5. Local Mode of Trip Indicators;
6. Selectable I²t on Short Time and Ground Fault Time Delays when those options are selected;
7. Local Four Digit Alphanumeric Display;
- 8.* Zone Interlock capabilities of the Breaker Short Time and Ground Fault Delay Functions, when those options are selected;
- 9.* Remote Relay Contacts for high load and mode of trip indication; and
10. For powered 610, 810, & 910 Trip Units: Once an overcurrent has occurred, the Trip Unit sends an electrical signal to the Direct Trip Actuator (DTA) which will be monitored until the Trip Unit is reset, keeping the Breaker in a trip free condition.

The Trip Unit also includes provisions to accept the required Rating Plug. The Rating Plug is equipped with a battery to light the local mode of trip indicators if the 120 VAC control power is lost.

* The Zone Interlock and ATR relay contacts are available on 610 Kits with normal External Harness. A popular option is to specify the Breaker Mounted CPT with a simplified External Harness in which case no Cell Harness is used. This option omits the Zone Interlock and remote relay connections, but does maintain the Alphanumeric Display and trouble shooting capability of the Digitrip RMS 610 Kit.

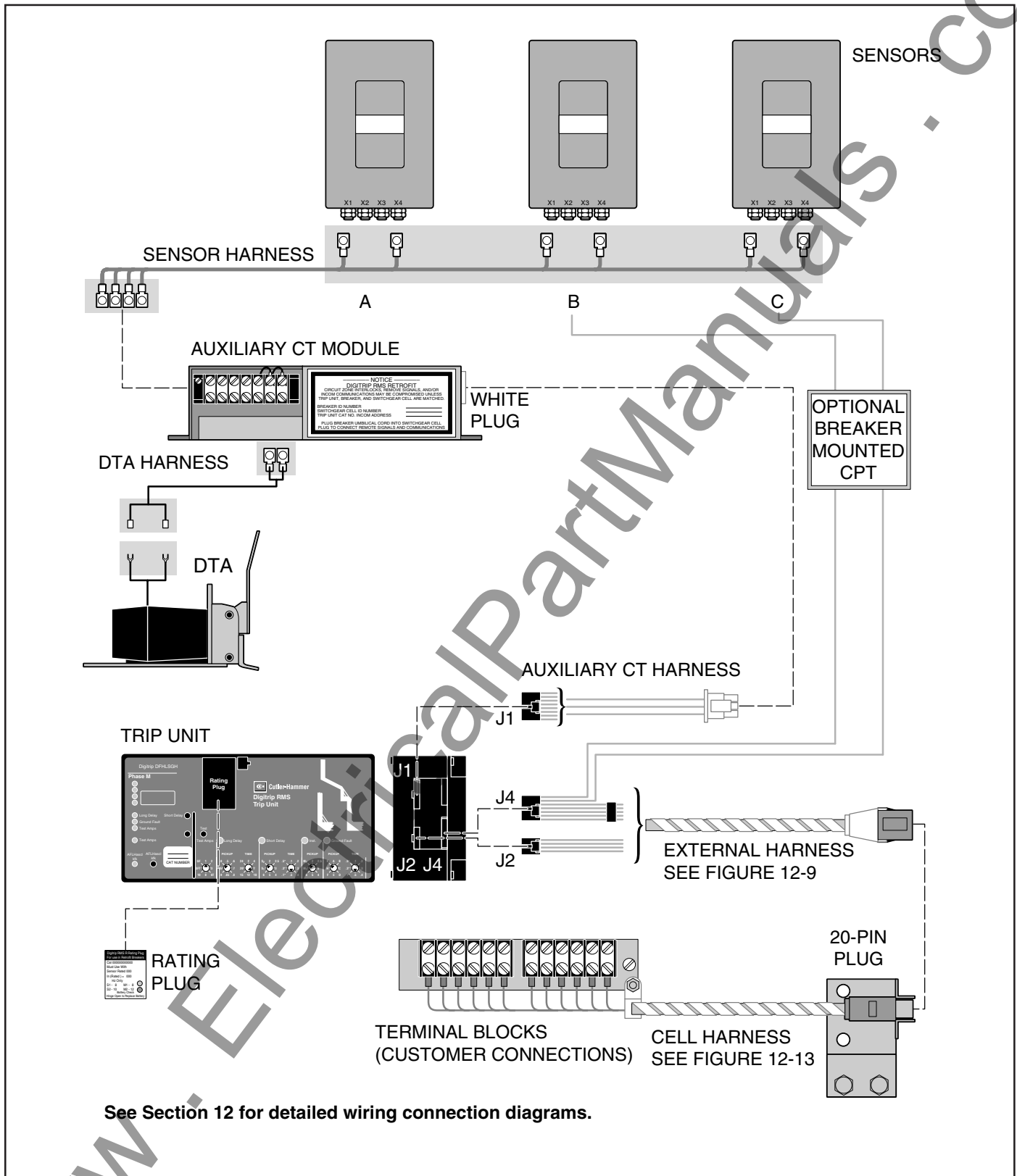

See Section 12 for detailed wiring connection diagrams.

Fig. 6-1 Digitrip RMS 610 Wiring

SECTION 7 DIGITRIP RMS 810 & 910 RETROFIT KITS

7.1 Digitrip RMS 810 & 910 Retrofit Kit Selection and Content

The Digitrip RMS 810 & 910 Retrofit Kit series are the top of the line of Retrofit Kits. The Retrofit Kits are available with the applicable Digitrip RMS Trip Unit Overcurrent Trip Functions, (i.e.: Long Time (L), Short Time (S), Instantaneous (I), and Ground Fault Time (G) Delays). The combinations available are LI, LS, LSI, LIG, LSG, LSIG.

Digitrip RMS 810 & 910 Retrofit Kits feature Communications Capability when applied with the Cutler-Hammer PowerNet System. The RMS 810 & 910 Kits have essentially the same content, except for the Trip Unit. The Communication, Zone Interlocks, and Remote Alarm Signals are extracted from the Trip Unit by an External Harness. The External Harness includes a 20-pin plug, which connects to the Cell Harness Assembly.

A 120 VAC control power source is required to power up the Power Relay Module (ATR) remote signals, the local mode of trip indicators, PowerNet Communications, and the Trip Unit Alphanumeric Digital Display. A Potential Transformer (PT) Module provides the distribution system voltage input to the Trip Unit. The PT Module is provided with a disconnect plug which is to be disconnected in the event of Breaker dielectric testing. Figures 7-1, 12-10, and 12-14 provide the Retrofit Kit wiring connections on the Breaker and in the Switchgear Cell. All Retrofit Kit components are mounted on the Breaker, except the Cell Harness Assembly.

The 120 VAC control power can be supplied externally, via wiring in the cell, or it can be supplied via a Breaker Mounted Control Power Transformer (CPT) which is optional with the Retrofit Kit.

7.2 Digitrip RMS 810 & 910 Retrofit Kit Features

Digitrip RMS 810 & 910 Trip Units have the following features available for customer use, when applied in Digitrip RMS Retrofit Kits:

1. Basic (L, S, I, G) Overcurrent Protection, as selected;
2. Defeatable Discriminator Capability, if instantaneous function is not provided;
3. LTM Memory Function;
4. True RMS Sensing;
5. Integral Trip Unit Testing;
6. Unit Status Indicator;
7. Local Mode of Trip Indicators;
8. Selectable I^2t on Short Time and Ground Fault Time Delays when those options are selected;
9. Local Four Digit Alphanumeric Display;
- 10.* Zone Interlock capabilities of the Breaker Short Time and Ground Fault Delay Functions, when those options are selected;
- 11.* Remote Relay Contacts for high load and mode of trip indication;
12. For Powered 610, 810, & 910 Trip Units: Once an overcurrent has occurred, the Trip Unit sends an electrical signal to the Direct Trip Actuator (DTA) which will be monitored until the Trip Unit is reset, keeping the Breaker in a trip free condition;

*The Zone Interlock and ATR Relay Contacts are available on 810 & 910 Kits with the normal Cell Harness. A popular option is to specify the Breaker Mounted CPT with a simplified Cell Harness. In this case, the Zone Interlock and ATR contacts are omitted and only the INCOMM connections are required in the Cell (Figure 7-1).

This option minimizes the Cell work required to just running the PowerNet twisted pair from Cell to Cell (see Section 10).

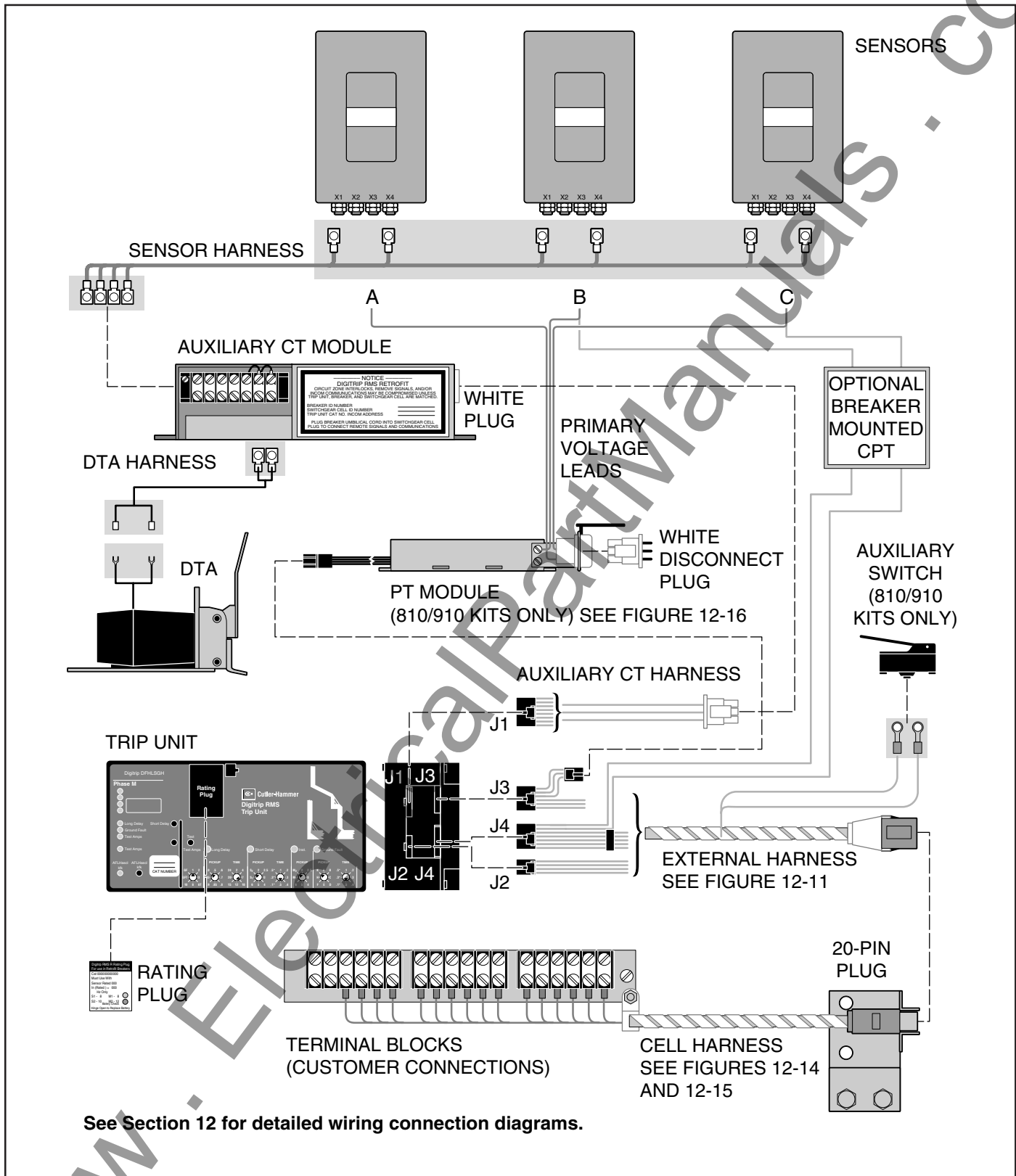

Fig. 7-1 Digitrip RMS 810 & 910 Wiring

- 13. Communications when applied with the Cutler-Hammer PowerNet System;
- 14. Energy Monitoring Capability;
- 15. Power Quality (Digitrip 910 only); and
- 16. System Voltage (Digitrip 910 Only).

The Trip Unit also includes provisions to accept the required Rating Plug. The Rating Plug is equipped with a battery to light the local mode of trip indicators if the 120 VAC control power is lost.

7.3 Power Flow Convention

For RMS 810 & 910 Kits, proper Power Flow Conventions must be maintained as follows to assure the Trip Unit reads positive power. The factors which affect this are the Direction of Power Flow, the Location of the Sensors (Top or Bottom), and the Polarity of the Sensor Connections.

In describing the Sensor Polarity, the “Common” is the Green Wire, and the “Dot” is the Polarity Mark, usually located near the X1 terminal on the Sensor.

Figure 7-2 should be consulted to determine the proper arrangement to allow the Trip Unit to read power properly. In all cases shown, the Current Sensors are mounted with the Sensor Nameplates facing out so that they can be read with the Sensor installed on the Breaker.

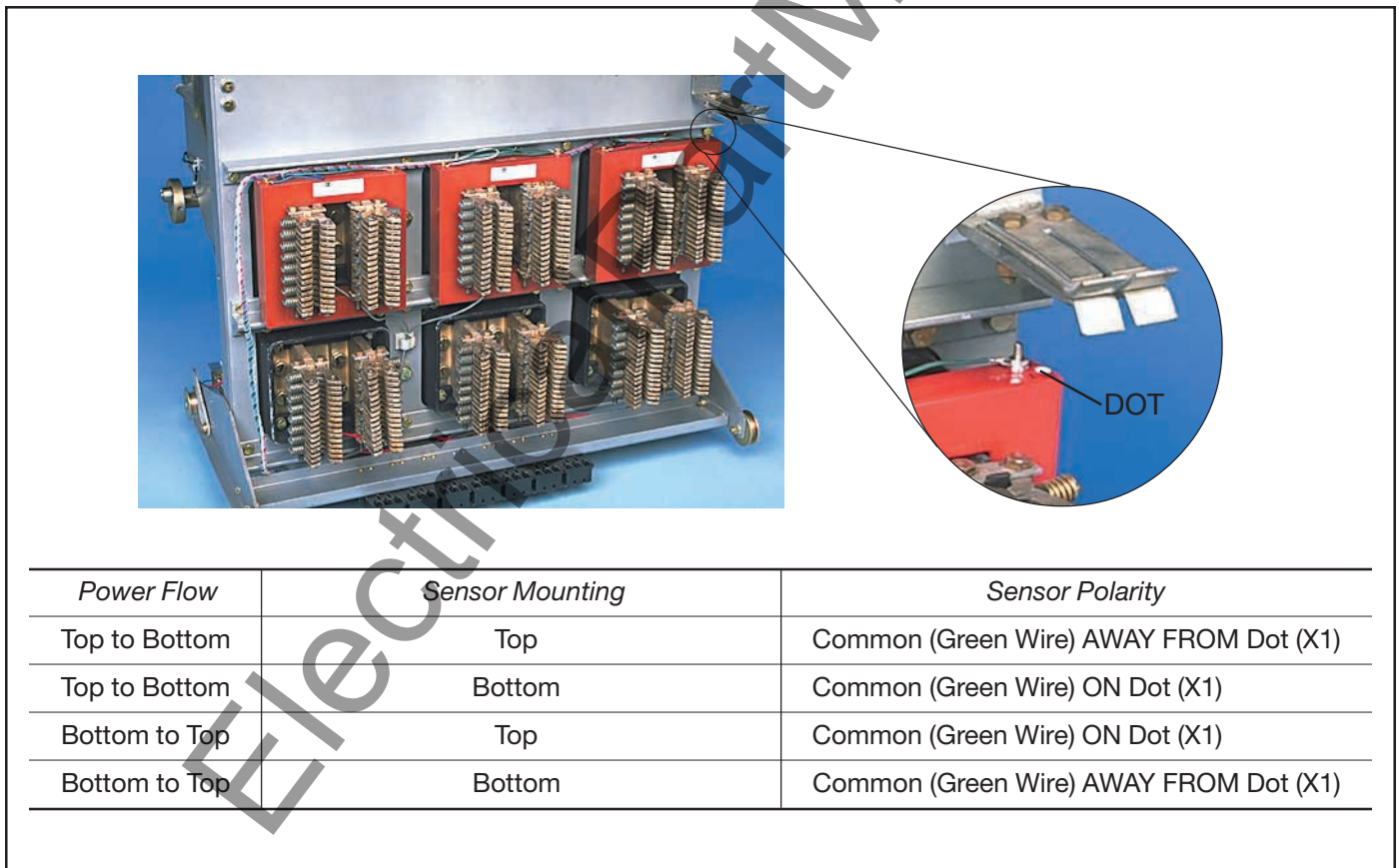

Fig. 7-2 Power Flow Conventions

7.4 PowerNet Communications Wiring Checkout

The Trip Unit, External Harness, and Cell Harness wiring for PowerNet communications can be confirmed as follows.

1. Place the Breaker in Test (Disconnected) position.
2. Remove the customer twisted pair connections COMM1, COMM2.
3. Remove the external 120 VAC power.
4. Connect an Ohm meter to COMM1 and COMM2 on the Terminal Block.
5. Keep the External Harness connected.
6. The Ohm meter should read approximately 1 to 2 ohms.
7. If (6) is OK, then the wiring is confirmed.

Remove the Ohm meter and replace wiring removed in Steps (2) and (3).

SECTION 8 TESTING RETROFITTED BREAKERS

8.1 Dielectric and Meggar Testing



WARNING

REFER TO SECTION 1, ENTITLED “GENERAL INFORMATION AND SAFETY PRECAUTIONS”, AND REVIEW ALL THE DIRECTIONS SET FORTH IN THAT SECTION PRIOR TO STARTING ANY TESTING PROCEDURE. FAILURE TO FOLLOW THE SAFE PRACTICES RECOMMENDED IN SECTION 1 COULD RESULT IN PERSONAL INJURY, DEATH, AND / OR EQUIPMENT DAMAGE. TESTING SHOULD ONLY BE CARRIED OUT BY PERSONNEL FAMILIAR WITH THE HAZARDS ASSOCIATED WITH WORKING ON POWER CIRCUIT BREAKERS AND SWITCHGEAR ASSEMBLIES.



CAUTION

TO AVOID POSSIBLE DAMAGE TO THE TRIP UNIT, PERFORM THE FOLLOWING TWO STEPS BEFORE APPLYING MORE THAN 600 VOLTS TO A BREAKER RETROFITTED WITH A DIGITRIP RMS TRIP SYSTEM.

1. Disconnect the white plug from the Potential Transformer (PT) Module. This action disconnects the Breaker Primary Voltage from the Trip Unit (RMS 810, 910, and OPTIM).
2. For kits with a Breaker Mounted Control Power Transformer (CPT), disconnect it from the Breaker by removing the two in-line fuses from the system voltage wires.

8.2 Trip System Testing – General Notes

- A. Each Retrofitted Breaker must be tested using the Primary Injection method to confirm the entire system operation (including Sensors) prior to installation. Use the test settings shown in Table 8-1.

Once the Breaker has been tested using the Primary Injection method, the Self-Test or the Secondary Injection method may be used for subsequent preventative maintenance testing. If you wish to test the Trip Unit at the customer's settings, then we suggest using Cutler-Hammers Digitest software program, which will facilitate any combination of settings. Please call Cutler-Hammer at 1-800-937-5487 for more information on the Digitest program.

- B. Each Retrofitted Breaker must be set up per the distribution system coordination study prior to installation.

- C. Digitrip Trip Units are calibrated, sealed at the factory, and are not repairable. Field testing of the Retrofit Kits confirms that the Retrofitted Breaker meets the published Time-Current Curves shown in Figures 3-2, 3-3, and 3-4.

Each pick-up or time setting on Digitrip Trip Units is selected by choosing one position of eight on each switch. However, the Discriminator function has an eight position “On / Off” switch. Positions one through seven (1 – 7) are “On” while position eight (8) is “Off” for the Discriminator function. Each switch setting has a tolerance band associated with it as defined in the Figures 3-2, 3-3, and 3-4.

Figure 8-1 shows the zones for pick-up and no pick-up. The Digitrip Trip Unit must not pick-up below Zone A (the pick-up tolerance zone) and must always pick-up above Zone A. Field pick-up testing of the Retrofit Kits must not be done within the tolerance zone (Zone A), since the Trip Unit may or may not pick-up within this zone. Below band testing, Zone B, confirms that the pick-up will not occur below the minimum pick-up level. Above band testing, Zone C, confirms that the pick-up will occur at or above the minimum pick-up level. Figure 8-1 also shows the tolerance zone for trip times. Field time testing confirms that the Breaker will trip within this time zone.

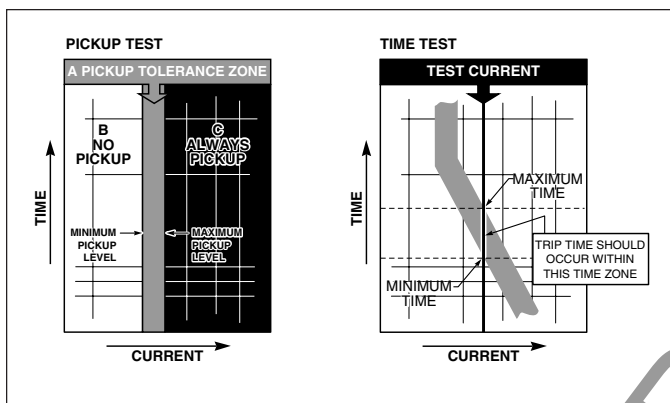

Fig. 8-1 Pick-up Test and Time Test

8.3 Recommended Test Accessories

1. **Auxiliary Power Module (APM)**
Catalog number – PRTAAPM,
Style number – 1267C16G01
 - Provides auxiliary power to the Trip Unit's microprocessor.
 - Applicable to all Retrofit Kits. It is required on Retrofit Kits with a Breaker Mounted CPT.
2. **120 VAC Power Supply with an On / Off switch Retrofitter supplied switch and plug.**
 - Reduces wear on the Auxiliary Power Module plugs.
 - Applicable to the Auxiliary Power Module and the test Cell Harness assembly.
3. **Test Cell Harness Assembly**
Style number – 6503C57G03
 - Shorts out Zone Interlocks.
 - Provides auxiliary power to the Trip Unit when equipped with a power cord and a 120 VAC power supply with an On / Off switch.
 - Applicable to 510 Retrofit Kits (with Zone Interlocks (ZSI)), 610 to 910 and OPTIM Retrofit Kits.
 - Not applicable to the 510 Basic Retrofit Kits (without Zone Interlocks).
4. **ZSI Shorting Plug**
Style number – 6502C83G01 for all Retrofit Kits except for the DS Retrofit Kit.
 - DS Retrofit Kits - standard with all Trip Units from 510 to OPTIM.
 - Shorts out Zone Interlocks.
 - Applicable to all Retrofit Kits when not using the Test Cell Harness Assembly to short out the Zone Interlocks.
5. **Amptector and Digitrip Test Set**
Style number – 8779C02G02
 - Tests the Trip Unit, DTA, and Auxiliary CT Module during Secondary Injection Testing.
 - Applicable to all Retrofit Kits for Secondary Injection Testing.

8.4 Explanation of Test Procedures

1. Defeat (Short Out) Zone Interlocks

- Ground Fault time and Short Delay time will be at the minimum values during testing, if not defeated.
- Use ZSI Shorting Plug or the Test Cell Harness Assembly.
- Already included on 510 Basic Retrofit Kits.

2. Defeat Unpowered Thermal Memory (LTM)

- LTM automatically reduces the time to trip the Breaker, if not defeated.
- Remove rating plug from the Trip Unit. Jumper is located at the back of the Rating Plug cavity.
- Move jumper to the right for horizontal Trip Units. Move jumper to the bottom position for vertical and standard Trip Units.
- Insert the Rating Plug back into the Trip Unit.

3. Defeat Ground Fault Trip Function (Primary Injection Testing Only)

- Will trip the Breaker on Ground Fault when testing the Long Delay trip function, if not defeated.
- Move the green wire from the “G” terminal to the “N” terminal (on the Auxiliary CT Module) before testing Long Delay, Short Delay, or Instantaneous (phase testing).
- Green wire must be returned to “G” terminal after phase testing.
- Required for all Trip Units equipped with Ground Fault protection.

4. Use Auxiliary Power

- Provide power to the Trip Unit for Primary Injection, Self, and Secondary Injection Testing.
- Use the Auxiliary Power Module and plug it into the front of the Trip Unit, or use Test Cell Harness Assembly and plug it into External Harness.

5. Reset Trip Unit (Resetting Powered Thermal Memory)

- If not reset, the LED will remain lit and reduce the Rating Plug’s battery life for 510 Trip Units.
- If not reset, the Breaker will be held in the Trip Free condition and the LED will remain lit for 610 to 910 Trip Units.

1st Reset Method

- With Auxiliary Power “On”, press Trip Unit’s Reset button.
- Turn Auxiliary Power “Off” for 10 seconds.
- Turn Auxiliary Power “On”.

2nd Reset Method

- With Auxiliary Power “On”, set the Test Amps to 1.
- Press and release the Trip Unit’s Test push button.
- Quickly press and release the Trip Unit’s Reset button before Trip Unit operates.

6. Reset Trip Settings

- See the appropriate table to apply the proper Trip Unit settings.

7. Abort Test

- Avoid overheating all the components during Primary Injection testing.
- Avoid overheating of the Aux. CT module and Trip Unit during Secondary Injection testing.
- Speeds up the testing process for a Self Test.
- Manually stop the test per the appropriate table, if the Breaker does not trip (see “Stop Test After” column).

8. Confirm Breaker Status

- Confirm the Breaker position indicator reads “OPEN” and the spring charged indicator reads “DISCHARGED”.
- After the tests are completed, change to the customer’s Trip Unit settings.

Notes

www.ElectricalPartManuals.com

8.5 Primary Injection Testing



WARNING

PRIMARY INJECTION TESTING CAUSES HEATING OF CIRCUIT BREAKER AND RETROFIT COMPONENTS. FAILURE TO STOP THE TESTS WHEN INSTRUCTED WILL CAUSE SERIOUS DAMAGE TO BOTH THE BREAKER AND RETROFIT COMPONENTS.

Primary Injection verifies the complete Breaker Overcurrent Protection System, including the Current Sensors, Rating Plug, Trip Unit, and the interconnecting wiring. It involves the use of a tester (e.g.: Multi-amp Tester or EIL) to inject single phase primary current through the Breaker to test the Digitrip RMS Overcurrent Trip System.

When testing on Breakers with Current Limiters, the Current Limiters should be removed and replaced by copper shorting bars during testing. Failure to do so could result in compromising the expected performance of the Current Limiters. The Current Limiters must be reinstalled after testing is completed.

If all of the tests from Table 8-1 yield correct results, the Trip Unit is functioning properly. If any difficulties are encountered during testing, please call Cutler-Hammer at 1-800-937-5487.

8.5.1 Primary Injection Test Procedures

A. Prior to Primary Injection Testing:

- Defeat Zone Interlocks;
- Defeat Unpowered Thermal Memory;
- Defeat Ground Fault trip function; and
- Use Auxiliary Power.

B. During Primary Injection Testing:

- Reset the Trip Unit;
- Reset the Trip Settings (see Table 8-1);
- Close the Breaker;
- Conduct the test (see Table 8-1);
- Abort the Test (see Table 8-1); and
- Record the Test Results.
 - Compare the actual results with the expected test results in Table 8-1.
 - 610, 810, & 910 Trip Units will display the elapsed time of the test and then display the cause of Trip Code.
 - Press the Step button to view the test current magnitude after each test.
 - Permanently record the results to verify calibration of the Trip System.

C. After Primary Injection Testing:

- Reset the Trip Unit;
- Confirm the Breaker Status; and
- Confirm the Ground Fault Trip Function is activated.

Table 8-1 Primary Injection Testing
Testing Settings

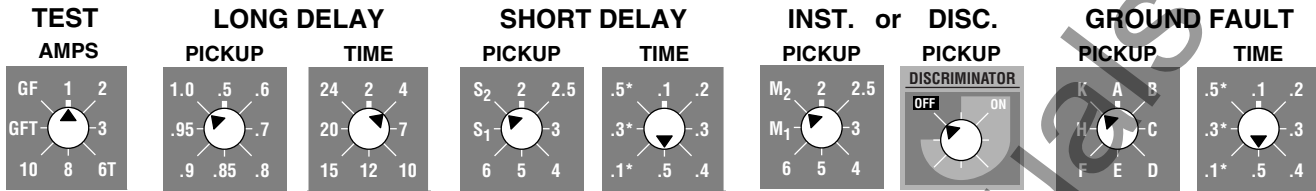

1. Long Delay Pickup Test (A)

1 1.0 4 S₂ .5[†] M₂ OFF K .5[†]

2. Long Delay Pickup Test (B)

1 1.0 4 S₂ .5[†] M₂ OFF K .5[†]

3. Long Time Test

1 1.0 4 S₂ .5[†] M₂ OFF K .5[†]

4. Short Delay Pickup Test (A)**

1 1.0 4 6 .5[†] M₂ OFF K .5[†]

5. Short Delay Pickup Test (B)

1 1.0 4 6 .5[†] M₂ OFF K .5[†]

6. Instantaneous Test (A)**

1 1.0 4 S₂ .5[†] 3 K .5[†]

7. Instantaneous Test (B)

1 1.0 4 S₂ .5[†] 3 K .5[†]

8. Discriminator Test

1 1.0 4 S₂ .5[†] ON K .5[†]

9. Ground Fault Test (A)

1 1.0 4 S₂ .5[†] 3 OFF A .5[†]

10. Ground Fault Test (B)

1 1.0 4 S₂ .5[†] 3 OFF A .5[†]

[†] Do not use the 5*; the I²t setting.

Expected Test Results

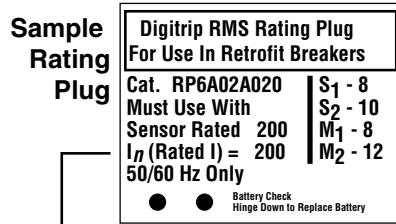

STOP TEST AFTER	PRIMARY AMPS	TRIP TIME	DISPLAY AMPS	FAULT DISPLAY	LED STATUS	BREAKER STATUS
5 SEC.	100% of I_n	NO TRIP	$1 \times I_n$	NONE	LONG DELAY OFF	NO TRIP
5 SEC.	115% of I_n	NO TRIP	$1.15 \times I_n$	LDPU	LONG DELAY FLASHING	NO TRIP
20 SEC.	300% of I_n	10.7 to 16 SEC.	$3 \times I_n$	LDT	LONG DELAY ON STEADY	TRIPPED
5 SEC.	250% of I_n	NO TRIP	$2.5 \times I_n$	LDT	LONG DELAY FLASHING	NO TRIP
5 SEC.	650% of I_n	.38 to .5 SEC.	$3.5 \times I_n$	SDT	SHORT DELAY ON STEADY	TRIPPED
5 SEC.	250% of I_n	NO TRIP	$2.5 \times I_n$	LDT	LONG DELAY FLASHING	NO TRIP
5 SEC.	350% of I_n	>.1 SEC.	$3.5 \times I_n$	INST	INST. ON STEADY	TRIPPED
5 SEC.	1300% of I_n	>.1 SEC.	$13 \times I_n$	DISC	DISC. ON STEADY	TRIPPED
5 SEC.	20% of I_n	NO TRIP	$0.2 \times I_n$	NONE	GND. FAULT OFF	NO TRIP
5 SEC.	30% of I_n	.38 to .5 SEC.	$0.3 \times I_n$	GNDT	GND. FAULT ON STEADY	TRIPPED

Notes

www.ElectricalPartManuals.com

8.6 Digitrip RMS Self-Testing System



WARNING

USE OF THE DIGITRIP RMS SELF-TEST SYSTEM, WHILE THE BREAKER IS IN THE “CONNECTED” POSITION IN THE SWITCHGEAR CELL COMPARTMENT, IS NOT RECOMMENDED. THE TRIPPING ACTION OF THE CIRCUIT BREAKER WILL CAUSE DISRUPTION OF SERVICE CAUSED BY UNNECESSARY SWITCHING OF CONNECTED EQUIPMENT.

TESTING SHOULD ONLY BE PERFORMED WHEN THE BREAKER IS LEVERED TO THE “TEST”, “DISCONNECTED”, OR “REMOVED” POSITIONS. FAILURE TO COMPLY WITH THESE RECOMMENDATIONS COULD RESULT IN INJURY, DEATH, AND / OR EQUIPMENT DAMAGE.

All Digitrip RMS 10-Series and 100-Series Trip Units are equipped with self-testing capability as standard.

The “Test Amps” settings are 1, 2, 3, 6T, 8, 10, GFT, and GF, each multiplied by the In rating. The Breaker will only trip when the (6T and GFT) settings are used.

The test is started by pushing and then releasing the Test push button. The Trip Unit will test itself based on the Test and Time Overcurrent settings selected, lighting the appropriate “Mode of Trip” LED.

If all of the tests from Table 8-2 yield correct results, the Trip Unit is functioning properly. If any difficulties are encountered during testing, please call Cutler-Hammer at 1-800-937-5487.

8.6.1 Self-Testing Procedures

A. Prior to Self-Testing:

- Defeat Zone Interlocks;
- Defeat Unpowered Thermal Memory; and
- Use Auxiliary Power.

B. During Self-Testing:

- Reset the Trip Unit;
- Reset the Trip Settings (see Table 8-2);
- Close the Breaker;
- Conduct the test (see Table 8-2);
- Abort the Test (see Table 8-2); and
- Record the Test Results.
 - Compare actual results with the expected test results in Table 8-2.
 - 610, 810, & 910 Trip Units will display the elapsed time of the test and then display the cause of Trip Code.
 - Press the Step button to view the test current magnitude after each test.
 - Permanently record the results to verify calibration of the Trip System.

C. After Self-Testing:

- Reset the Trip Unit; and
- Confirm the Breaker Status.

Table 8-2 Self-Testing of the Digitrip Trip Unit Settings

Testing Settings

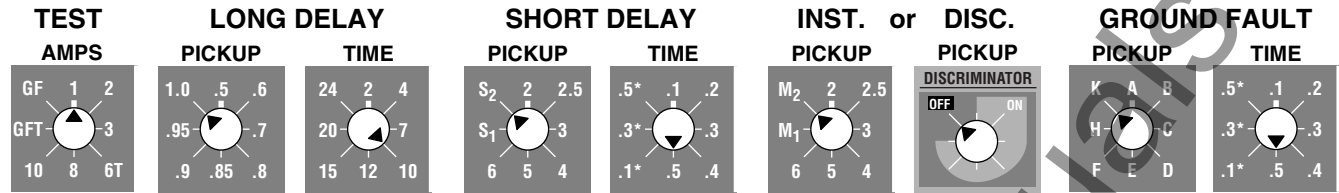

1. Long Delay Pickup Test (A)

1	1.0	10	S ₂	.5 [†]	M ₂	OFF	K	.5 [†]
---	-----	----	----------------	-----------------	----------------	-----	---	-----------------

2. Long Delay Pickup Test (B)

1	.95	10	S ₂	.5 [†]	M ₂	OFF	K	.5 [†]
---	-----	----	----------------	-----------------	----------------	-----	---	-----------------

3. Long Time Test

6T	1.0	10	S ₂	.5 [†]	M ₂	OFF	K	.5 [†]
----	-----	----	----------------	-----------------	----------------	-----	---	-----------------

4. Short Delay Pickup Test (A)

6T	1.0	10	S ₁	.5 [†]	M ₂	OFF	K	.5 [†]
----	-----	----	----------------	-----------------	----------------	-----	---	-----------------

5. Short Delay Pickup Test (B)

6T	1.0	10	5	.5 [†]	M ₂	OFF	K	.5 [†]
----	-----	----	---	-----------------	----------------	-----	---	-----------------

6. Instantaneous Test (A)

6T	1.0	10	S ₂	.5 [†]	M ₁	OFF	K	.5 [†]
----	-----	----	----------------	-----------------	----------------	-----	---	-----------------

7. Instantaneous Test (B)

6T	1.0	10	S ₂	.5 [†]	5	OFF	K	.5 [†]
----	-----	----	----------------	-----------------	---	-----	---	-----------------

8. Ground Fault Test (A)

GFT	1.0	10	S ₂	.5 [†]	5	OFF	K	.5 [†]
-----	-----	----	----------------	-----------------	---	-----	---	-----------------

9. Ground Fault Test (B)

GFT	1.0	10	S ₂	.5 [†]	5	OFF	K	.1 [†]
-----	-----	----	----------------	-----------------	---	-----	---	-----------------

† Do not use the .5*; the I²t setting.

Expected Test Results

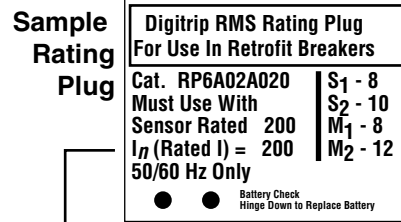

STOP TEST AFTER	TRIP TIME	DISPLAY AMPS	FAULT DISPLAY	LED STATUS	BREAKER STATUS
5 SEC.	NO TRIP	1 x I _n	NONE	LONG DELAY OFF	NO TRIP
5 SEC.	NO TRIP	1 x I _n	NONE	LONG DELAY FLASHING	NO TRIP
15 SEC.	6.7 to 10 SEC.	6 x I _n	LDT	LONG DELAY ON STEADY	TRIPPED
15 SEC.	6.7 to 10 SEC.	6 x I _n	NONE	LONG DELAY ON STEADY	TRIPPED
5 SEC.	.38 to .5 SEC.	6 x I _n	SDT	SHORT DELAY ON STEADY	TRIPPED
15 SEC.	6.7 to 10 SEC.	6 x I _n	LDT	LONG DELAY ON STEADY	TRIPPED
5 SEC.	>.1 SEC.	6 x I _n	INST	INST. ON STEADY	TRIPPED
5 SEC.	.38 to .5 SEC.	1 x I _n	GNDT	GND. FAULT ON STEADY	TRIPPED
5 SEC.	>.1 SEC.	1 x I _n	GNDT	GND. FAULT ON STEADY	TRIPPED

8.7 Testing Digitrip with the DS Breaker Secondary Injection Test Kit

Digitrip RMS Trip Units can be tested over a partial range using AMPTECTOR & DIGITRIP TEST SET and an Optional Test Kit Adapter Harness. The available Adapter Harnesses are listed in Table 2-2 and are described as follows.

- 1. Adapter Method 1** – Insert the test kit banana plug into the receptacle end of the Adapter Harness (#6503C53G01), then attach the labeled spade terminals to the Aux. CT Module Terminal Block Terminals “A” through “On”. This Adapter Harness must be manually connected to the Breaker for the test and removed afterwards (see Figure 8-2A).
- 2. Adapter Method 2** – Insert the test kit banana plug into the receptacle end of the Adapter Harness (#6503C54G01) then insert the Adapter Harness’s 12-pin male plug into the Breaker Mounted Harness (#6503C55G01) (see Figure 8-2B).

NOTE: The Breaker Mounted Test Plug is an optional accessory, sold as a kit for permanent mounting on each Breaker. It includes a 12-pin female plug with a set of seven (7) labeled spade type terminals which connect to the Aux. CT Module terminals “A” through “On”.

- 3. Adapter Method 3** - Insert the test kit banana plug into the receptacle end of the DS Adapter (#8779C02G03) then insert the DS Adapter’s 9-pin male plug into the Second Adapter Harness (#6503C54G02). Insert the 12-pin male plug of the Harness (#6503C54G02) into the Breaker Mounted Harness (#6503C55G01) (see Figure 8-2C).

NOTE: The DS Breaker Secondary Injection Test Kit produces a maximum of 30 to 35 amperes when connected to the Test Kit Adapter Harness. The Test Kit outputs are limited to 6-to-7 times the Rating Plug In Rating. This restricts the test range for Short Delay and Instantaneous Testing, but still provides for testing the Long Delay Pickup and Long Delay Time Trip Functions. An external power source to the Trip Unit is required for Secondary Injection Testing. Use either the Auxiliary Power Module (APM) or the 120 VAC input through the Breaker External Harness (RMS 610, 810, & 910 only) as discussed above. Additional information for testing Digitrip RMS with the test kit is listed in the “References” section of this document.

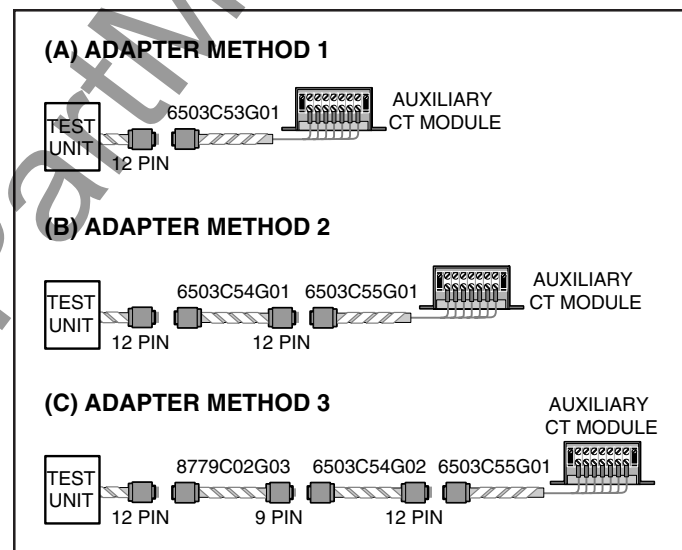

Fig. 8-2 Adapter Methods

8.7.1 Secondary Injection Testing



WARNING

DO NOT USE THE AMPTECTOR TEST KIT TO TEST DIGITRIP RMS WHILE THE BREAKER IS IN THE “CONNECTED” POSITION IN THE SWITCHGEAR CELL COMPARTMENT. TESTING SHOULD ONLY BE PERFORMED WHEN THE BREAKER IS LEVERED TO THE “TEST”, “DISCONNECTED” OR “REMOVED” POSITIONS. FAILURE TO COMPLY WITH THESE RECOMMENDATIONS COULD RESULT IN PERSONNEL INJURY, DEATH, AND / OR EQUIPMENT DAMAGE.

POSSIBLE DAMAGE TO THE DIGITRIP TRIP UNIT MAY RESULT FROM THE USE OF STYLE NUMBERS 140D481G01R OR G02 TEST KITS. ONLY USE A TEST KIT WITH STYLE NUMBER 8779CO2G02 FOR TESTING THE DIGITRIP TRIP UNIT.

The tester secondary amps, shown in Table 8-3, are for 100% Rating Plugs, where the Plug Rating (In) and Sensor Rating are the same. If your Rating Plug is not 100%, it will be necessary to ratio the secondary amps accordingly.

If all of the tests from Table 8-3 yield correct results, the Trip Unit is functioning properly. If any difficulties are encountered during testing, please call Cutler-Hammer at 1-800-937-5487.

8.7.2 Secondary Injection Test Procedures

A. Prior to Secondary Injection Testing:

- Defeat Zone Interlocks;
- Defeat Unpowered Thermal Memory; and
- Use Auxiliary Power.

B. During Secondary Injection Testing:

- Reset the Trip Unit;
- Reset the Trip Settings (see Table 8-3);
- Close the Breaker;
- Conduct the test (see Table 8-3);
- Abort the Test (see Table 8-3); and
- Record the Test Results.
 - Compare actual results with the expected test results in Table 8-3.
 - 610, 810, & 910 Trip Units will display the elapsed time of the test and then display the cause of Trip Code.
 - Press the Step button to view the test current magnitude after each test.
 - Permanently record the results to verify calibration of the Trip System.

C. After Secondary Injection Testing:

- Reset the Trip Unit; and
- Confirm the Breaker Status.

Table 8-3 DS Breaker Secondary Injection Testing
Testing Settings

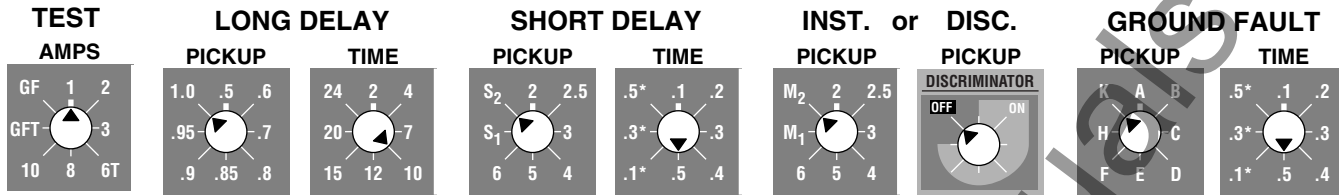

1. Long Delay Pickup Test (A)

1	1.0	10	S ₂	.5 [†]	M ₂	OFF	K	.5 [†]
---	-----	----	----------------	-----------------	----------------	-----	---	-----------------

2. Long Delay Pickup Test (B)

1	1.0	10	S ₂	.5 [†]	M ₂	OFF	K	.5 [†]
---	-----	----	----------------	-----------------	----------------	-----	---	-----------------

3. Long Time Test

1	1.0	10	S ₂	.5 [†]	M ₂	OFF	K	.5 [†]
---	-----	----	----------------	-----------------	----------------	-----	---	-----------------

4. Short Delay Pickup Test (A)

1	1.0	10	6	.5 [†]	M ₂	OFF	K	.5 [†]
---	-----	----	---	-----------------	----------------	-----	---	-----------------

5. Short Delay Pickup Test (B)

1	1.0	10	6	.5 [†]	M ₂	OFF	K	.5 [†]
---	-----	----	---	-----------------	----------------	-----	---	-----------------

6. Instantaneous Test (A)**

1	1.0	10	S ₂	.5 [†]	6	OFF	K	.5 [†]
---	-----	----	----------------	-----------------	---	-----	---	-----------------

7. Instantaneous Test (B)

1	1.0	10	S ₂	.5 [†]	6	OFF	K	.5 [†]
---	-----	----	----------------	-----------------	---	-----	---	-----------------

8. Ground Fault Test (A)

1	1.0	10	S ₂	.5 [†]	6	OFF	A	.5 [†]
---	-----	----	----------------	-----------------	---	-----	---	-----------------

9. Ground Fault Test (B)

1	1.0	10	S ₂	.5 [†]	5	OFF	A	.5 [†]
---	-----	----	----------------	-----------------	---	-----	---	-----------------

[†] Do not use the .5*; the I²t setting.

Expected Test Results

Sample Rating Plug

Digitrip RMS Rating Plug	
For Use In Retrofit Breakers	
Cat. RP6A02A020	S ₁ - 8
Must Use With	S ₂ - 10
Sensor Rated 200	M ₁ - 8
I _n (Rated I) = 200	M ₂ - 12
50/60 Hz Only	
● ● Battery Check Hinge Down to Replace Battery	

STOP TEST AFTER	SECONDARY AMPS	TRIP TIME	DISPLAY AMPS	FAULT DISPLAY	LED STATUS	BREAKER STATUS
5 SEC.	4.9	NO TRIP	.98 x I _n	NONE	LONG DELAY OFF	NO TRIP
5 SEC.	5.7	NO TRIP	1.14 x I _n	LDPU	LONG DELAY FLASHING	NO TRIP
15 SEC.	30	6.7 to 10 SEC.	6 x I _n	LDT	LONG DELAY ON STEADY	TRIPPED
5 SEC.	25	9.6 to 14.4 SEC.	5 x I _n	LDT	LONG DELAY FLASHING	NO TRIP
5 SEC.	35	.38 to .5 SEC.	7 x I _n	SDT	SHORT DELAY ON STEADY	TRIPPED
5 SEC.	25	NO TRIP	5 x I _n	LDT	LONG DELAY FLASHING	NO TRIP
5 SEC.	35	>.1 SEC.	7 x I _n	INST	INST. ON STEADY	TRIPPED
5 SEC.	1.0	NO TRIP	.2 x I _n	NONE	GND. FAULT OFF	NO TRIP
5 SEC.	1.5	.38 to .5 SEC.	.3 x I _n	GNDT	GND. FAULT ON STEADY	TRIPPED

8.8 Circuit Breaker Checkout and Bench Test

Before the Breaker is returned to the Switchgear for placement into service, the Retrofit Kit installation must be checked out and tested. Check all Breaker Retrofit wiring paths to be sure that they are properly routed and free from potential interference with moving parts within the Breaker. Confirm that all Wiring Harness terminations are secure.

Perform several Breaker Manual Close and Overcurrent Trip Operations. This test can be performed using any of the above described test methods. An effective installation checkout and test procedure should include the following.

1. Select and set the proper, user determined Overcurrent Trip Settings for the Digitrip RMS Trip Unit. Verify the Trip Unit is in calibration by selecting and testing several trip points (as applicable) on the Long Delay, Short Delay, Instantaneous, and Ground Fault Time portions of the Digitrip RMS Trip Curve. Record the Trip Unit settings for permanent record and future reference. Reset the Trip Unit after testing or the Rating Plug battery will discharge.

2. Verify the Direct Trip Actuator (DTA) properly resets. The Breaker will not close unless the DTA resets.
3. For Breakers equipped with Overcurrent Trip Switches (OTS), confirm the proper operation of the OTS. When the Breaker trips on an overcurrent condition, the OTS must latch and its contacts change state. If not, adjust the OTS as detailed in OTS Adjustment Procedures in manufacturer's original instructions that accompanied the Breaker or Switchgear.

Manually reset the OTS after each trip through the push button on the Breaker Faceplate or electrically, if applicable, by energizing the OTS Reset Coil.

Before returning the Breaker to the Switchgear after Breaker bench testing has been completed, lever the Breaker element levering mechanism from the "TEST" position to the "DISCONNECT" position. Confirm the Breaker position indicator reads "OPEN" and the spring charged indicator reads "DISCHARGED".

SECTION 9 OPERATION

**WARNING**

REFER TO SECTION 1 ENTITLED “GENERAL INFORMATION AND SAFETY PRECAUTIONS” AND REVIEW ALL THE DIRECTIONS SET FORTH IN THAT SECTION, PRIOR TO STARTING ANY TESTING PROCEDURE. FAILURE TO FOLLOW THE SAFE PRACTICES RECOMMENDED IN SECTION 1 COULD RESULT IN PERSONAL INJURY, DEATH AND/OR EQUIPMENT DAMAGE. OPERATION OF THIS EQUIPMENT SHOULD ONLY BE CARRIED OUT BY PERSONNEL FAMILIAR WITH WORKING ON POWER CIRCUIT BREAKERS AND SWITCHGEAR ASSEMBLIES.

The information presented for the operation of Digitrip RMS Retrofitted Power Circuit Breakers and Switchgear supplements the content of the original equipment instruction manuals. Further, the information described supplements any established procedures in practice at the customer location.

**WARNING**

BREAKER AND SWITCHGEAR CELL RETROFIT INSTALLATIONS MUST BE CHECKED AND TESTED PRIOR TO PLACING THE EQUIPMENT IN OPERATION. SECTION 8 PROVIDES INFORMATION ON RECOMMENDED TESTING AND CHECKOUT PROCEDURES. FAILURE TO FOLLOW SUCH PROCEDURES COULD RESULT IN PERSONAL INJURY, DEATH, AND / OR EQUIPMENT DAMAGE.

9.1 Breaker Insertion in Switchgear Cell and Power Up

**WARNING**

PRIOR TO INSERTING THE BREAKER INTO THE CELL, BE SURE THE BREAKER IS IN THE OPEN POSITION AND THE TRIP UNIT ADJUSTABLE SETTINGS ARE CORRECT. ADDITIONALLY, BE SURE THE TRIP UNIT, BREAKER AND SWITCHGEAR CELL ALL MATCH FOR THEIR INTENDED APPLICATION. FAILURE TO DO SO COULD RESULT IN PERSONAL INJURY, DEATH, AND / OR EQUIPMENT DAMAGE.

NOTE: It is the responsibility of the Retrofitter to install the Retrofitted Breaker in the Cell to insure proper Breaker / Cell fit and correct Breaker operation.

Rack the Breaker to the CONNECT position in the Switchgear Cell. RMS 510 Basic Retrofitted Breakers include no External Harness and are ready to be closed. For RMS 510 Zone, 610, 810, & 910 Retrofitted Breakers, plug the External Harness into the Cell Harness Assembly and then close the Breaker. The External Harness connects the External Trip Unit Signals. For RMS 610, 810, & 910 Retrofitted Breakers, the Trip Unit “Green” Status LED will begin to blink when the plug is connected, indicating the Trip Unit is operational and the 120 VAC external source is on. For RMS 610, 810, & 910 Retrofitted Breakers with an optional Breaker Mounted Control Power Transformer (CPT), the 120 VAC external source is derived from the Line side of the Breaker. For RMS 510 Basic and RMS 510 Zone Retrofitted Breakers, the Trip Unit “Green” Status LED will begin to blink when the Breaker is closed and Primary Current of at least 25% of the Sensor Tap selected begins to flow.

NOTE: Digitrip RMS Overcurrent Protection is maintained, even when the Breaker External Harness Plug is not plugged into the Cell Harness Plug. The Digitrip RMS Overcurrent Trip System is internally powered by the primary phase currents passing through the Current Sensors.

9.2 Information Available to Operator While Breaker Is in Service

Table 9-1 lists the available information provided by Digitrip RMS Trip Units while the Breaker is in service.

Table 9-1

<i>Data available local to, or remote from, the Digitrip RMS Trip Unit during operation.</i>	<i>RMS 510</i>	<i>RMS 610</i>	<i>RMS 810</i>	<i>RMS 910</i>
Unit Status Green LED flashes to indicate normal operation of Trip Unit.	X	X	X	X
Long Delay Red LED flashes when Breaker is in Long Delay Pickup and timing out to trip.	X	X	X	X
High Load Red LED lights when current level stays within 85% of Long Delay Pickup for 40 seconds.		X	X	X
ATR High Load contact closes for remote indication when current level stays within 85% of Long Delay Pickup for 40 seconds.		X	X	X
Alphanumeric Digital Display, showing: LDPU (Flashing) when Breaker in Long Delay Pickup; Individual Phase Currents (reading in amps x 1000); Ground Current (reading in amps x 1000); Peak Demand (Mega Watts); Present Demand (Mega Watts); Energy (Mega Watt Hours).		X	X	X
Depress STEP push-button to view selected field.		X	X	X
Depress RESET push-button to reset peak demand.			X	X
Communications Data Available for remote use at master PC, including: Trip Unit PowerNet Address (set at Trip Unit); Breaker Status (open or closed); Reason for Status (normal, LDPU alarm, or other); Breaker Rating Plug Installed; High Load Indication; Individual Phase Current levels (amps); Ground Current levels (amps); Peak Demand (Mega Watts); Present Demand (Mega Watts); Energy (Mega Watt Hours); Power Factor; Power Quality (Harmonics); Voltage.			X	X

9.3 Information Available in the Event of a Trip

In the event of a Trip, the Digitrip RMS Trip Unit provides information as summarized in Table 9-2 for operator use.

Table 9-2

<i>Data available local to, or remote from, the Digitrip RMS Trip Unit during operation.</i>	<i>RMS 510</i>	<i>RMS 610</i>	<i>RMS 810 & 910</i>
Red LEDs light to provide Trip Indication of: Long Delay Trip; Short Delay Trip; Instantaneous Trip; Ground Fault Trip; Discriminator/Override Trip (LS and LSG only).	X X X X X	X X X X X	X X X X X
Alphanumeric Digital Display Shows: LDT (Coded message for Long Delay Trip); SDT (Coded message for Short Delay Trip); INST (Coded message for Instantaneous Trip); GNDT (Coded message for Ground Fault Trip); DISC (Coded message for Discriminator Trip); EXTT (Coded message for External Trip via PowerNet); Phase Currents at trip (reading in amps x 1000); Ground Current at trip (reading in amps x 1000); Peak Demand (Mega Watts) at trip; Present Demand (Mega Watts); Energy (Mega Watts Hours) at trip; Depress STEP push-button to delete coded message ; and view stored data as selected.		X X X X X X X X X X X X	X X X X X X X X X X X
ATR contacts close for remote indication of: Long Delay Trip; Short Delay Trip; Long Delay Trip.		X X X	X X X
Communications data available for remote use as master PC: Device Address (set at Trip Unit); Breaker Status (Trip).			X X
Reason for Status: LDT (Coded message for Long Delay Trip); SDT (Coded message for Short Delay Trip); INST (Coded message for Instantaneous Trip); GNDT (Coded message for Ground Fault Trip); DISC (Coded message for Discriminator Trip); EXTT (Coded message for External Trip via PowerNet); Phase Currents at trip (reading in amps x 1000); Ground Current at trip (reading in amps x 1000); Peak Demand (Mega Watts) at trip; Present Demand (Mega Watts Hours); Energy (Mega Watts Hours) at trip.			X X X X X X X X X X X

9.4 Resetting The Trip Unit After a Trip

Following an Overcurrent Trip, the Trip Unit is reset by depressing the TRIP RESET push button. The Trip Unit should be reset before the Breaker is closed.

The RMS 510 Retrofit Trip Unit mode of trip LEDs are powered by the Rating Plug battery. The Breaker can be closed without resetting the Trip Unit, however the LED will remain lit until the Trip Unit TRIP RESET push button is depressed. Resetting the Trip Unit in a timely manner saves on battery life. In new condition, the battery will power the LED for approximately 60 hours.

The RMS 610, 810, & 910 Retrofits have provisions for 120 VAC source. If the 120 VAC source is "ON," the Breaker will be held in the Trip Free Condition (cannot be closed) by the Direct Trip Actuator (DTA) until the Trip Unit TRIP RESET push button is depressed. The Trip Unit mode of trip LEDs are powered by the 120 VAC source, and backed up by the battery in the Rating Plug. If the 120 VAC source to the Trip Unit is lost, the Trip Unit acts as described for the RMS 510.

The RMS 810 & 910 Retrofits have communications capability, which permit opening and (for electrically operated Breakers) closing via PowerNet. In the event of an Overcurrent Trip, the Trip Unit will act as described, requiring local resetting of the Trip Unit before the Breaker can be closed. However, if the Breaker is tripped remotely via PowerNet (alphanumeric coded message EXT1), it can be closed via PowerNet without local resetting at the Trip Unit.

9.5 Removing the Breaker From the CONNECT Position

RMS 510 Basic Retrofitted Breakers include no External Harness and require no special procedures (other than those normally observed) for removing the Breaker from the CONNECT position in the Switchgear Cell.

RMS 510 Zone, 610, 810, & 910 Retrofitted Kits are equipped with an External Harness. Care must be observed to disconnect the External Harness Plug from the Switchgear Cell Harness Assembly when removing the Breaker from the CONNECT position.

NOTE: If the Cell Terminal Block, Wiring Harness, and Plug Assembly are properly positioned in the Switchgear Cell with respect to the Breaker, the Breaker can be withdrawn to the TEST position with the External Harness plugged in. However, to withdraw the Breaker completely from the cell, the External Harness must be disconnected.



CAUTION

FAILURE TO DISCONNECT THE EXTERNAL HARNESS FROM THE CELL HARNESS ASSEMBLY IN THE SWITCHGEAR CELL COULD CAUSE PHYSICAL DAMAGE TO THE EQUIPMENT.

SECTION 10 DIGITRIP RMS RETROFIT SWITCHGEAR ASSEMBLY APPLICATIONS

10.1 Zone Interlocking

Zone Selective Interlocking (ZSI) capabilities are available with Digitrip RMS 510, 610, 810, & 910 Trip Units. ZSI provides positive system coordination by allowing the Breaker closest to the fault to trip without any preset time delay. This is achieved by setting up the distribution system as shown in the adjacent diagram. The hard wired connection between Trip Units sends a restraining signal upstream, allowing the Breaker closest to the fault to trip instantaneously.

ZSI's superior system coordination ensures that the Breaker closest to the fault will trip without preset time delays while reducing stress on the distribution system.

10.1.1 Zone Selective Interlocking

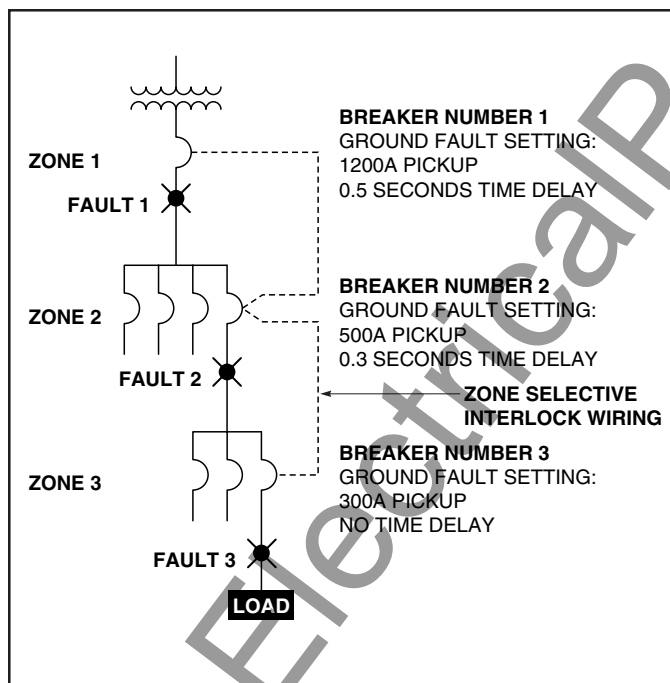

Fig. 10-1 Zone Selective Interlocking

Fault 1 – There are no interlocking signals. The main Breaker Trip Unit will initiate the trip instantaneously.

Fault 2 – The feeder Breaker Trip Unit will initiate the trip instantaneously to clear the fault; and Zone 2 will send an interlocking signal to the Zone 1 Trip Unit. The Zone 1 Trip Unit will begin to time out and, in the event that the feeder Breaker in Zone 2 would not clear the fault, the main Breaker in Zone 1 will clear the fault in 0.5 seconds.

Fault 3 – The branch Breaker Trip Unit will initiate the trip instantaneously to clear the fault; Zone 3 will send an interlocking signal to the Zone 2 Trip Unit; and Zone 2 will send an interlocking signal to Zone 1.

Zone 1 and Zone 2 Trip Units will begin to time out and, in the event that the branch breaker in Zone 3 would not clear the fault, the feeder breaker in Zone 2 will clear the fault in 0.3 seconds. Similarly, in the event that the feeder breaker in Zone 2 would not clear the fault, the main breaker in Zone 1 will clear the fault in 0.5 seconds.

NOTE: Digitrip RMS Zone Interlocking will trip the Breaker instantaneously on Short Time (S) or Ground Fault (G) Delay Trip Functions unless it is defeated as described in the following text.

For RMS 510 Basic Retrofit Kits, Zone Interlock functions are not wired out from the Trip Unit. The External Harness provided consists of a small jumper plug that shorts out the Zone Interlock signals at the Trip Unit.

For RMS 510 Zone, 610, 810, & 910 Retrofit Kits, Zone Interlock functions are available at the Cell Harness assembly as shown in Figure 12-12. The Breaker External Harness plugs into the Cell Harness Assembly, which includes provisions for external wiring connections as shown in Figure 12-12. Shorting jumpers are provided at the Terminal Block Assembly to defeat the Zone Interlock functions. These jumpers can be removed and selective Zone Interlocking schemes applied. Typical connection schemes for multiple Circuit Breakers are shown in Figures 10-2 and 10-3.

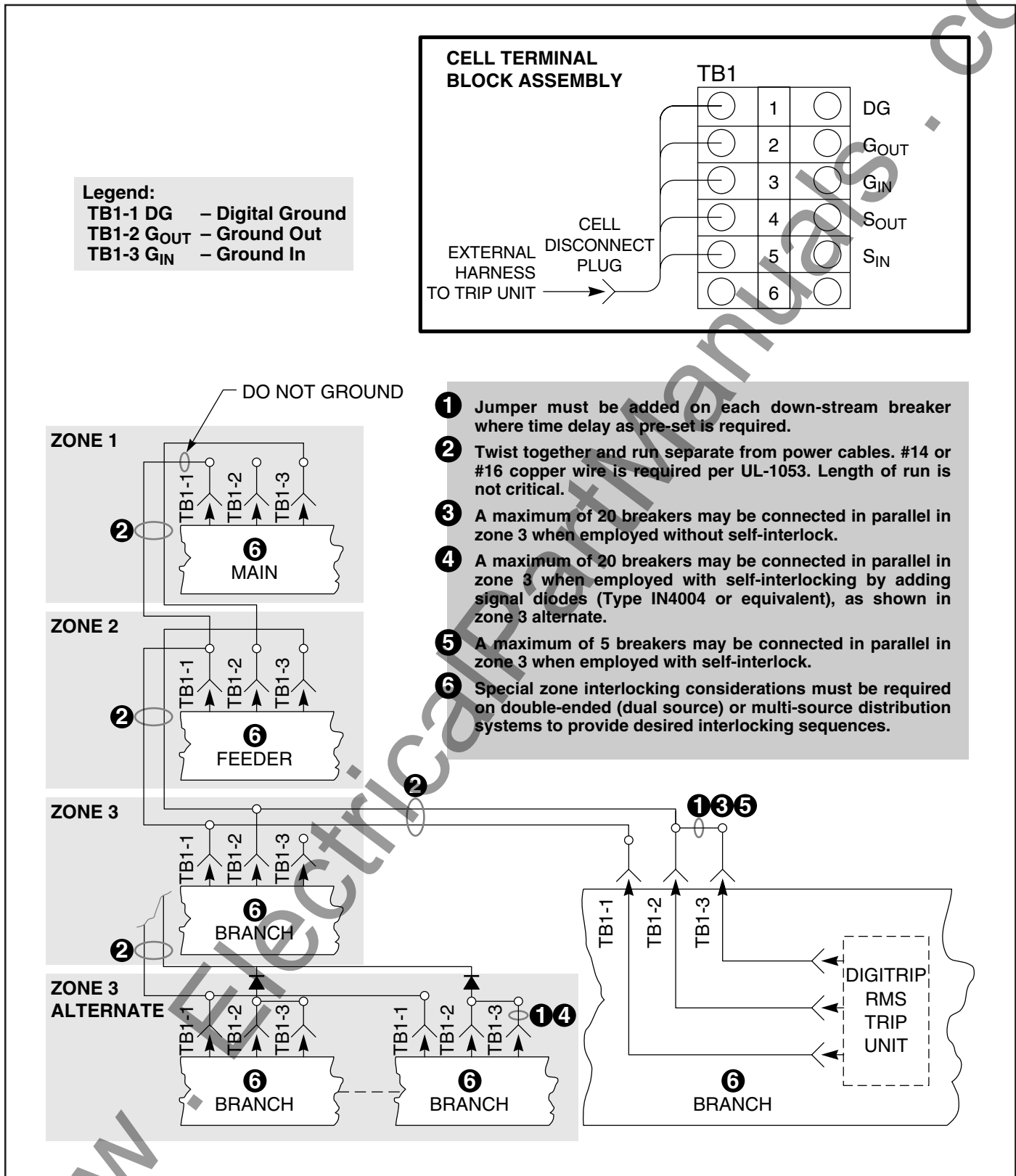

Fig. 10-2 Connection Schematics for Multiple Circuit Breakers

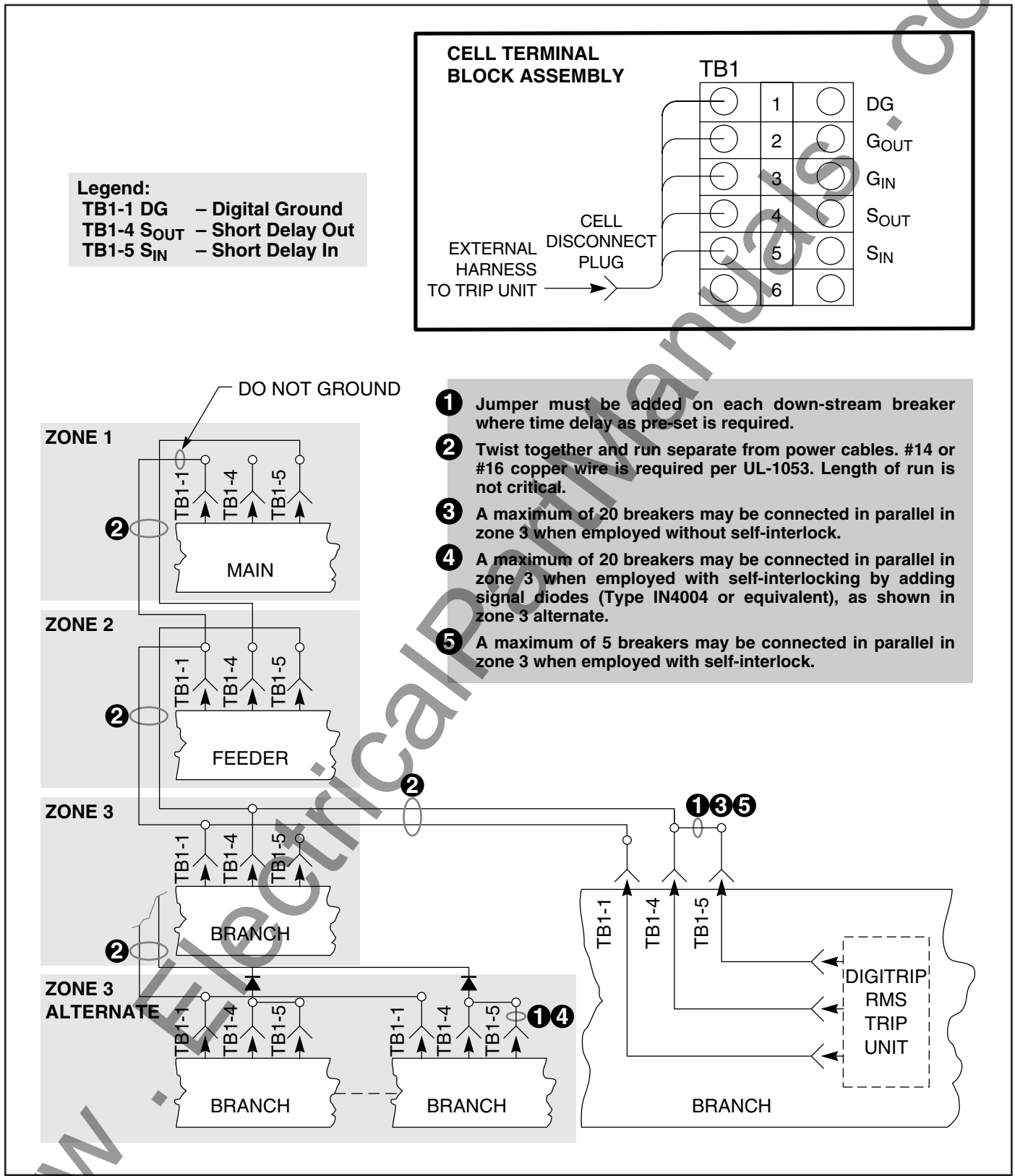

Fig. 10-3 Connection Schematics for Multiple Circuit Breakers

10.2 Setting Digitrip RMS Communications Address (Digitrip RMS 810 & 910 Kits Only)

NOTE: Setting Digitrip RMS PowerNet Address provides the Trip Unit a unique identification for communications. PowerNet Communications may be compromised unless the Trip Unit, Breaker, and Switchgear Cell are matched.

To enable the INCOMM communications system to identify each Circuit Breaker individually, the Digitrip RMS 810 & 910 Trip Units have a unique three digit "ADDRESS" which INCOMM uses to identify the Trip Unit and the Circuit Breaker it controls.

NOTE: Digitrip 810 & 910 Trip Units will already contain a factory-set Baud Rate and Address which, in general, will not apply to your network. For proper communications, each Trip Unit Address and Baud Rate must be set to the values applicable for your network. Similarly, prior to the installation of a Trip Unit into its Circuit Breaker, or prior to installation of a Circuit Breaker into its compartment (after maintenance for example), the user should verify that the Baud Rate and Address are correct. Failure to use the correct Baud Rate or Address can confuse the communication system. It is recommended that the appropriate Baud Rate, Address, and Circuit Breaker Cell location or bus or circuit reference be recorded in the spaces provided on the Trip Unit Display Panel, for future reference (see Figure 10-4).

The user can view the present Address and assign a new 3-digit Address by the following the procedure detailed below.

NOTE: The Breaker need not be open and may be carrying current.

1. Press and continue to hold in the "Trip Reset" push button (see Figure 10-4).
2. Watch the display window and, after about 5 seconds, the kA, MW, or MWh value will disappear, and either the letter H or L (Baud Rate code), followed by the 3-digit Address (between 001 and 999, there is no 000) will appear. (You do need to continue to hold in the "Trip Reset" push button.)
3. To increment the Address, press and release the "Demand Reset" push button near the display window (see Figure 10-2). The Address will increase by one unit each time you press the Demand Reset push button. If you press and hold the Demand Reset push button, the Address will increase continuously, slowly at first, and then faster as you continue to hold the button in. (Continue to hold in the Trip Reset push button while you do this.)
4. To decrement the Address, press and release the "Step" push button, also located near the display window (see Figure 10-4). The Address will decrease by one unit each time you press the Step push button. If you press and hold the Step push button, the Address will decrease continuously, slowly at first, and then faster as you continue to hold the button in. (Continue to hold in the Trip Reset push button while you do this.)
5. The letter "H" refers to the High (9,600) Baud Rate; and the letter "L" refers to the Low (1,200) Baud Rate. An "X" in the Baud Rate field indicates that neither High nor Low Baud Rate has been selected. Press and release the "Test" push button to change the Baud Rate. (You do need to continue to hold in the Trip Reset push button.)

Suggestion: Before you press and release the "Test" push button, set the "Test Amps" switch to 1 to minimize the effect of an unintended test, which can occur if your other finger would happen to come off the "Trip Reset" push button. For correct communications, be sure to use the Terminating Resistor at the end of the twisted pair (last element in the INCOMM chain). Figures 10-5, 10-6, and 10-7 show the location of the Terminating Resistor. Refer to T. D. 17-531 for the correct PowerNet wiring specification.
6. When the Address and Baud Rate code in the display window are correct, release the "Trip Reset" push button to save the values into the Trip Unit's non-volatile memory, and the kA, MW, or MWh value will return to the display window. If control power is lost, the Trip Unit will still know its (new) Address and Baud Rate.

NOTE: If control power is lost while you are changing the Address or Baud Rate (i.e.: while you are still holding in the “Trip Reset” push button), the display will go blank and when the control power is restored, the Trip Unit will still retain the previous Address and Baud Rate values, as if you had not been trying to change them.

NOTE: As shown in Figure 10-4, there is a space to record both the INCOMM Address and the Cell Number (to identify the Breaker location within the assembly) to the left and below the display window. Because Trip Units and Circuit Breakers of the same

rating are interchangeable, if more than one has been withdrawn for maintenance at one time, it is critical that each unit be returned to its correct Cell location so that the circuit has the correct Address.

For example, if two identical Breakers (one whose Trip Unit Address is 001 and the other whose Address is 100) were switched, the INCOMM communications system will be confused and the information coming from the 001 Trip Unit, as well as the commands going to the 001 Trip Unit, will actually involve the 100 circuit, and vice versa.

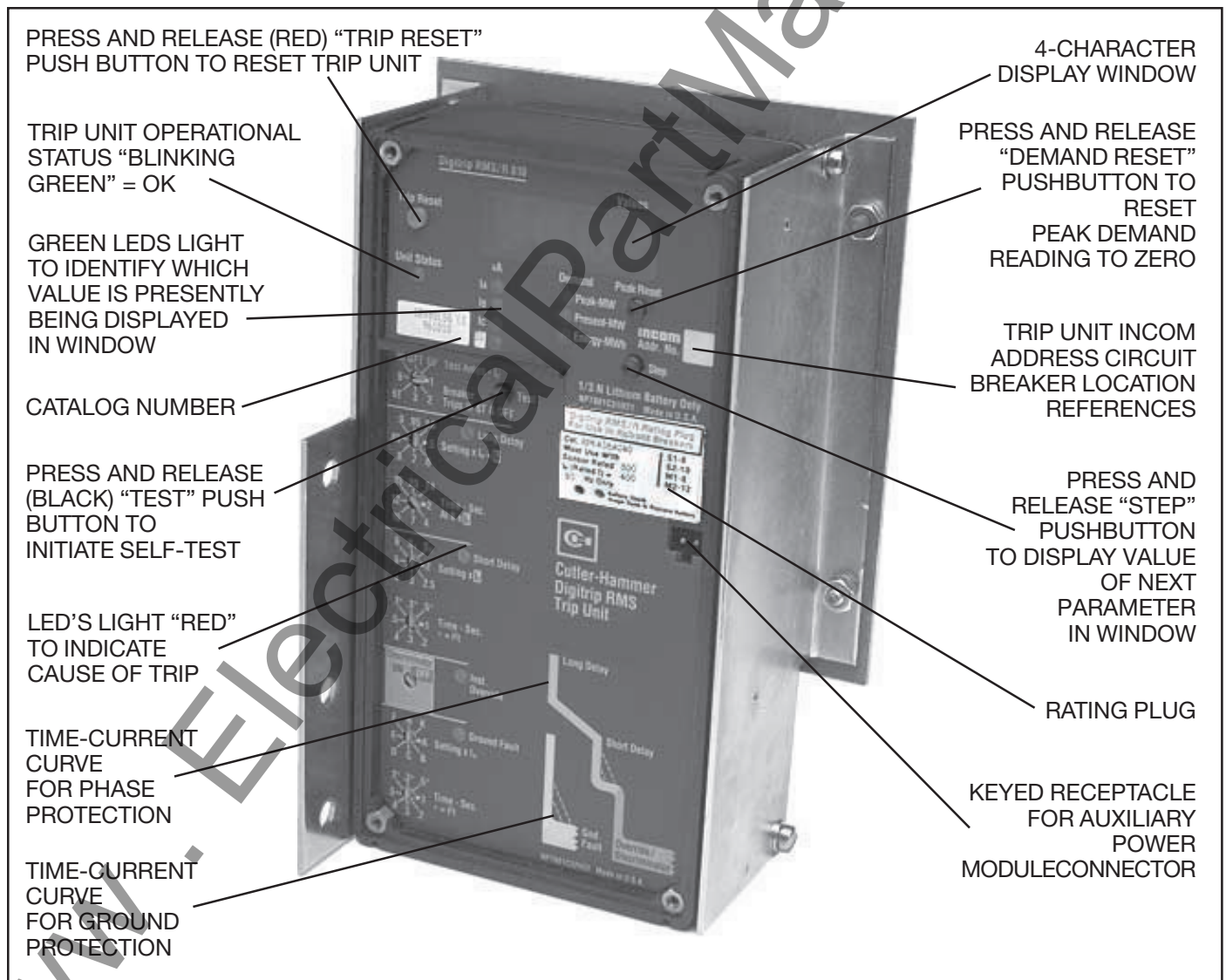

Fig. 10-4 Digitrip Trip Unit Display Panel

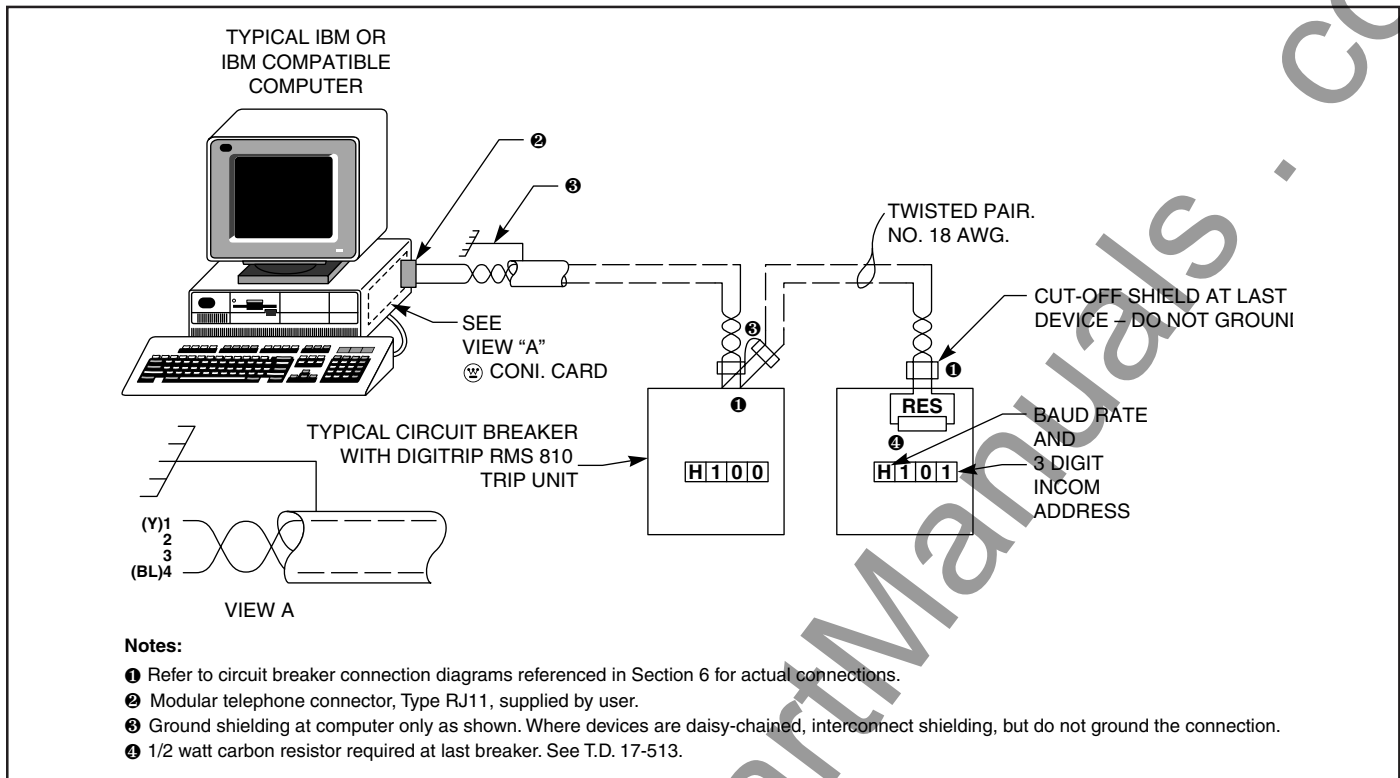

Fig. 10-5 Terminating Resistor Location

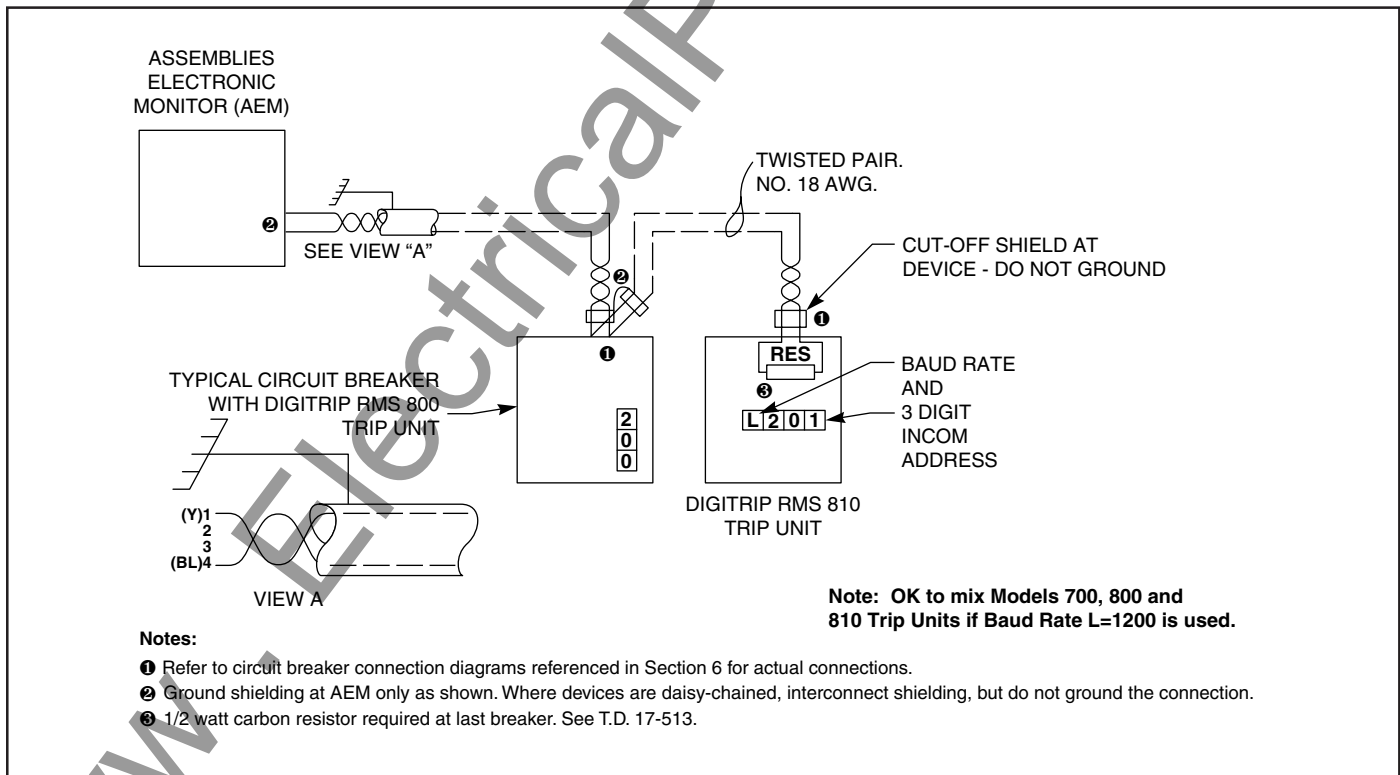

Fig. 10-6 Terminating Resistor Location

10.3 Identification of Trip Unit, Breaker, and Switchgear Cell

Your Digitrip RMS Retrofit Kit includes identification labels for the Digitrip RMS Trip Unit, the Breaker Element Faceplate, and the inside of the Switchgear Cell Door. It is important to identify all three, especially when the Trip Unit has a PowerNet address (Models 810 & 910 only).

10.4 The Power Relay Module (ATR)

RMS 610, 810, & 910 Retrofit Kits include the Power Relay Module (ATR), which is mounted integral to the RMS Trip Unit. The ATR input and output signals are extracted from the Trip Unit Plug J4 through the External Harness as shown in Figure 12-9. The Breaker External Harness plugs to the Cell Harness Assembly, which includes provisions for external wiring connections as shown in Figure 6-1. Figure 10-8 shows typical ATR 120 VAC source input and dry contact alarm output connections for remote alarm indication.

10.5 Communications and PowerNet

RMS 810 & 910 Retrofit Kits include communications capability when used with Cutler-Hammer's PowerNet System. Each RMS Trip Unit includes an Integrated Communications Chip that permits the extraction of Trip Unit data and the implementation of Breaker close and trip commands from a remote master computer. Communication is accomplished from the Trip Unit to the master computer via radio frequency signal over a twisted pair communications network. The communications signal (COMM1 and COMM2) are extracted from Trip Unit Plug J3 through the External Harness as shown in Figure 12-10. The Breaker External Harness plugs to the Cell Harness Assembly, which includes provisions for external wiring connections as shown in Figure 7-1. Figures 10-9 through 10-12 show typical Cell wiring provisions if the PowerNet computer close feature is to be utilized.

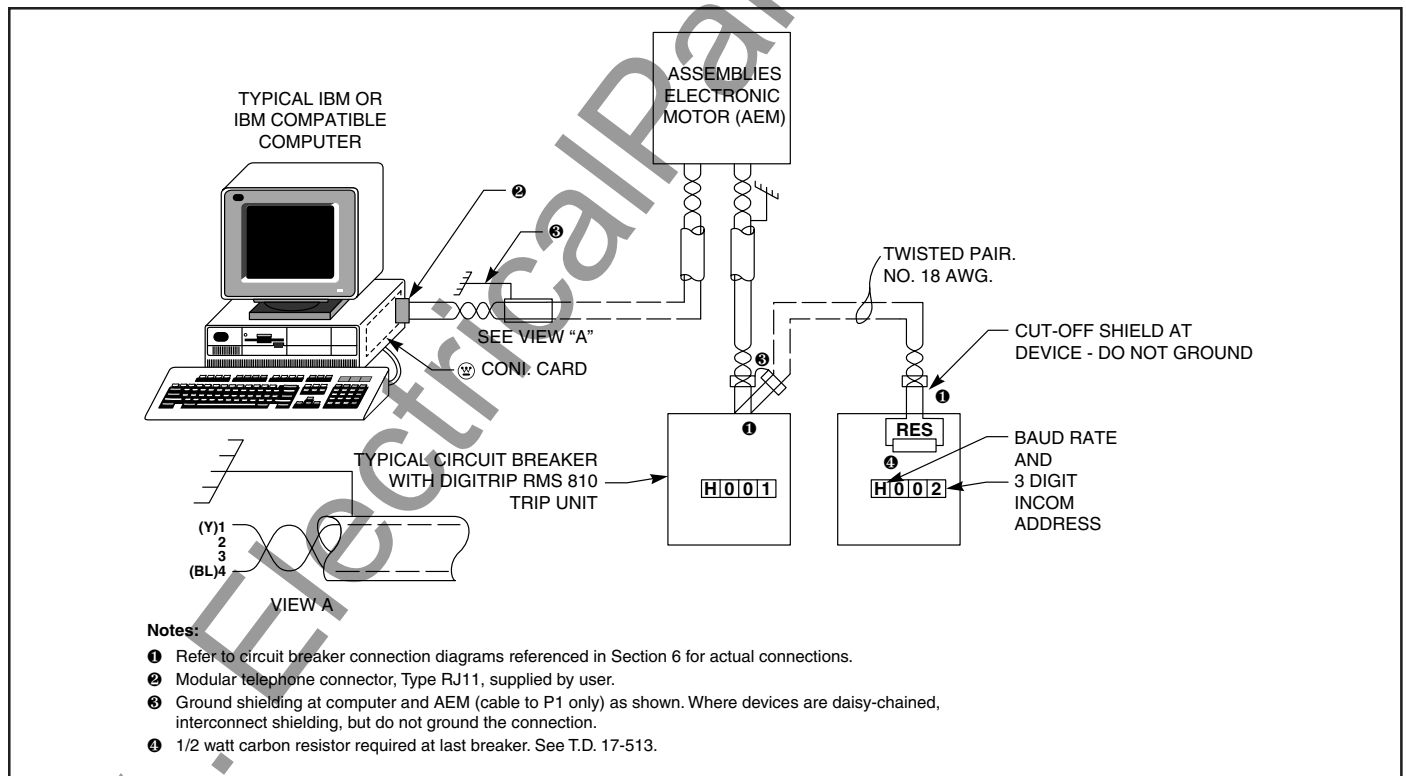

Fig. 10-7 Terminating Resistor Location

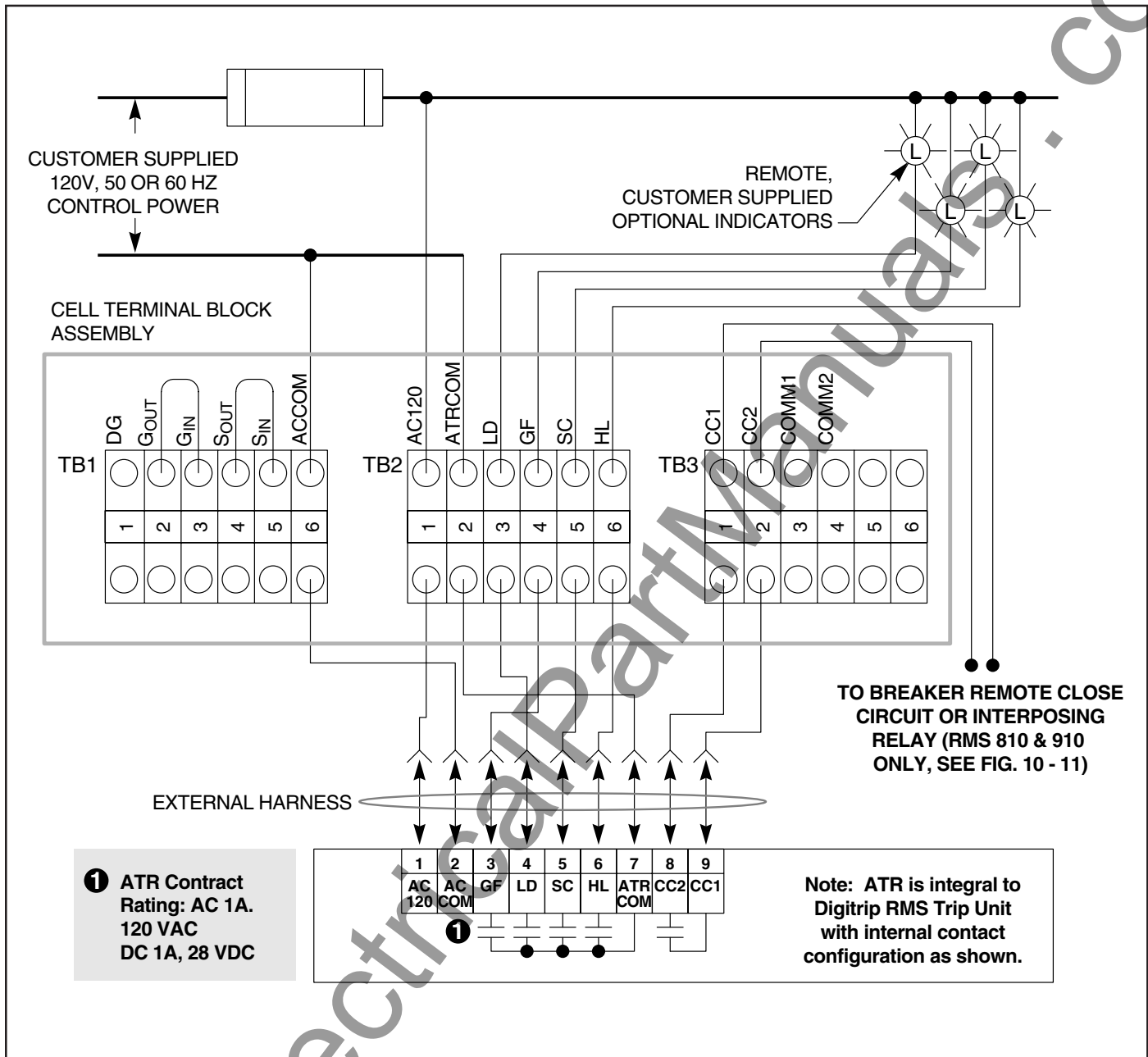

Fig. 10-8 Typical ATR 120 VAC Source Input and Dry Contact Alarm Output Connections for Remote Alarm Indications

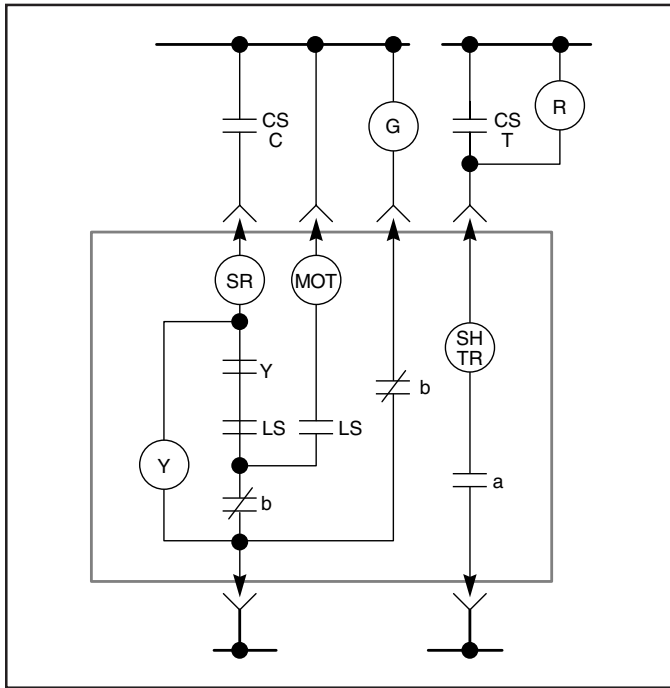

Fig. 10-9 Typical Control Schematic Without CC1 / CC2 Modification

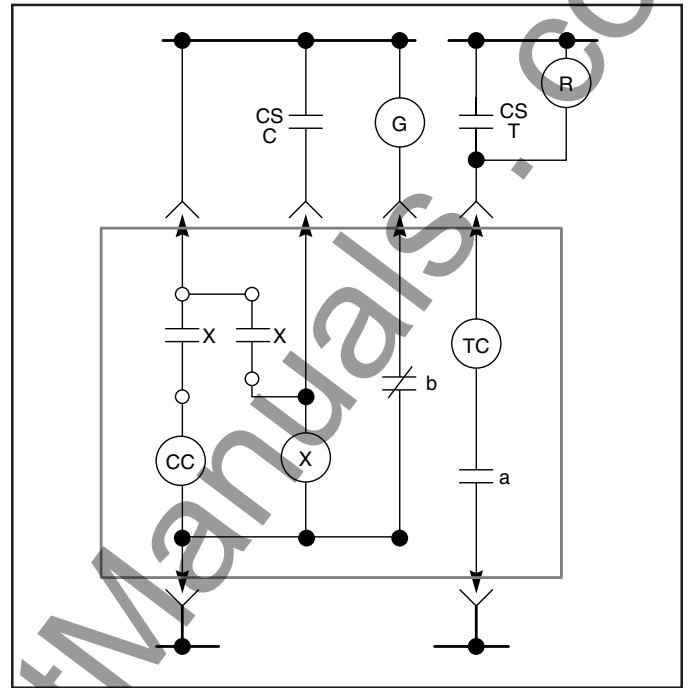
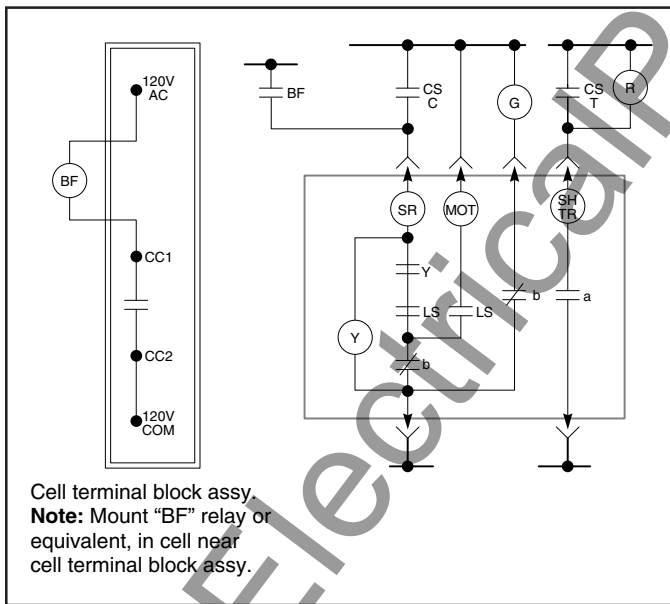
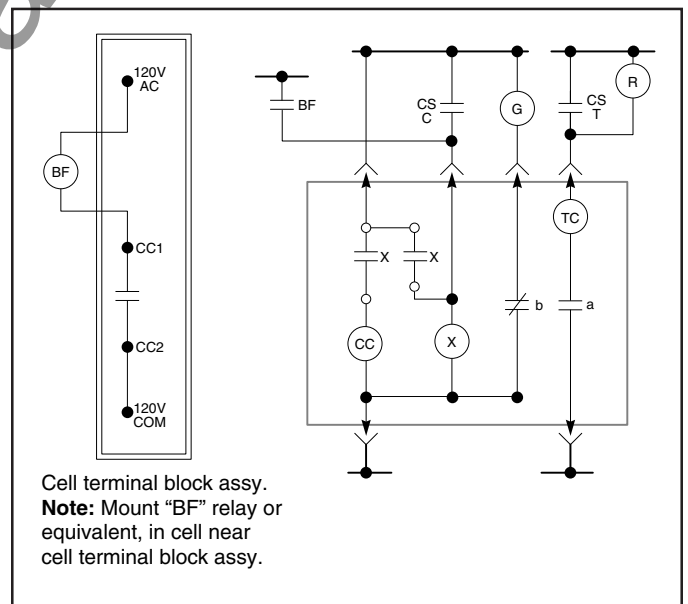

Fig. 10-10 Typical Control Schematic Without CC1 / CC2 Modification



Cell terminal block assy.
Note: Mount "BF" relay or equivalent, in cell near cell terminal block assy.

Fig. 10-11 CC1 / CC2 Modification to a Typical Control Schematic (Stored Energy)



Cell terminal block assy.
Note: Mount "BF" relay or equivalent, in cell near cell terminal block assy.

Fig. 10-12 CC1 / CC2 Modification to a Typical Control Schematic (Solenoid)

Notes

www.ElectricalPartManuals.com

SECTION 11 MAINTENANCE, WARRANTY, AND SERVICE INFORMATION

11.1 Preventative Maintenance Program

A periodic maintenance program is essential to assure Breaker and Switchgear reliability and integrity. Periodic maintenance, including testing, inspection, adjustment, and repair should be performed on both the Circuit Breaker and the Switchgear Assembly. For normal operating conditions, a minimum periodic interval of 12 months is recommended. However, additional factors, such as equipment age, state of repair, general condition, local operating environment, number of annual cycles, etc. must be considered in determining an effective maintenance interval.

11.2 Breaker Maintenance

Installation of a Digitrip RMS Retrofit Kit on an existing Circuit Breaker does not alleviate the user from maintaining the Circuit Breaker in good operating condition. The Digitrip RMS Trip System will greatly enhance the capability of the Circuit Breaker to reliably and accurately detect and initiate a trip in the event of an overcurrent condition or fault. However, the ability of the Breaker to trip and clear the fault is directly dependent on the operating condition of the Breaker.

The user should continue to follow the applicable instructions and procedures provided by the Breaker manufacturer and incorporate them into a periodic preventative maintenance program. The following items are not all inclusive, but should be an integral part of such a program:

1. *Cleanliness:* Breaker moving parts, insulation, and current carrying parts should be kept clean from dust, dirt, and sludge.
2. *Lubrication:* The Breaker operating mechanism should open (trip) and close properly and not stick, bind, or jam. The Breaker should be lubricated as required according to the manufacturer's recommendations.
3. *Contact Condition and Adjustment:* Breaker moving and stationary arching and main contacts should be in proper adjustment, in good condition, and free from burning and pitting. Breaker primary and secondary disconnecting contacts should be in good condition.

4. *General Condition and Repair:* Breaker hardware should be tight and retaining rings intact. Worn out parts should be replaced or repaired. Electrical connections and wire insulation should be sound and free from evidence of overheating.
5. *Digitrip RMS Trip System:* Section 8 provides recommended testing procedures for Digitrip RMS Trip System.

11.3 Warranty Procedure

Digitrip RMS Retrofit Kits include a limited warranty for components for one (1) year from the date of shipment. In the event of a warranty problem with a Retrofit Kit component contact Cutler-Hammer by the channel through which the Retrofit Kit was purchased. Contact the Cutler-Hammer Retrofit Kit distributor, representative, or installer (as applicable) and provide the following information:

1. Original order number by which the kit component was purchased;
2. Part description;
3. Part catalog and/or style number; and
4. Complete description of the problem.

If the problem is covered under warranty, instructions will be provided for obtaining a component replacement or for returning the component for repair.

11.4 Digitrip RMS Trip Unit Warranty

Digitrip RMS Trip Units are factory sealed and are not field serviceable. Breaking the factory seal, opening the Trip Unit, and tampering with the internal components will void any warranty. In the event of a problem with the Trip Unit, contact your local Cutler-Hammer representative per the instructions provided in 11-3 above.

Notes

www.ElectricalPartManuals.com

SECTION 12 DETAILED WIRING OF HARNESSES AND RELATED COMPONENTS

12.1 Sensor Harness Wiring

To cover both 3 and 4 wire system applications, the Sensor Harness includes two wires to permit the 4th wire connection. These two wires (one tan and one green) are readily identifiable; they are the longest two wires that protrude from the Sensor end of the harness. Determine the applicable wiring diagram (Figure 12-1, 12-2, 12-3 and 12-4) for your application, and perform the following.

1. If the retrofit is for a 3-wire system (Figure 12-1 or 12-2), the wires provided for the 4th wire connection are not needed. Remove the terminals from the long ends of the green and tan wires, then use an Ohm meter to confirm the other ends and remove them by sliding them out of the harness.
2. If the retrofit is for a 4-wire system (Figure 12-3 or 12-4,) the green and tan wires provided for the fourth connection are required for connection to an open set of Breaker Secondary Contacts.
3. In describing the Sensor Polarity, the “Common” is the Green Wire, and the “Dot” is the Polarity Mark, usually located near the X1 terminal on the Sensor.

Table 12-1 should be consulted to determine the proper arrangement to allow the Trip Unit to read power properly. In all cases shown, the Current Sensors are mounted with the Sensor Nameplates facing out so that they can be read with the Sensor installed on the Breaker.

NOTE: For 4-wire grounded systems, the Breaker and Cell Secondary Contacts are not included in the kit. These items must be ordered separately from the Original Equipment Manufacturer. The 4th Sensor for the Switchgear neutral is included when ordered with the Retrofit kit. The 4th Sensor is mounted on the neutral bus bar. It is the responsibility of the Retrofitter to locate an appropriate place to mount the 4th Sensor and to insure proper Breaker operation.

12.2 Auxiliary CT Harness Wiring

Figure 12-5 shows the detailed wiring connections for the Auxiliary CT Harness.

12.3 Auxiliary CT Module Wiring

Figure 12-6 shows the detailed wiring for the Auxiliary CT Module.

Table 12-1 Power Flow Conventions

<i>Power Flow</i>	<i>Sensor Mounting</i>	<i>Sensor Polarity</i>
Top to Bottom	Top	Common (Green Wire) AWAY FROM Dot (X1)
Top to Bottom	Bottom	Common (Green Wire) ON Dot (X1)
Bottom to Top	Top	Common (Green Wire) ON Dot (X1)
Bottom to Top	Bottom	Common (Green Wire) AWAY FROM Dot (X1)

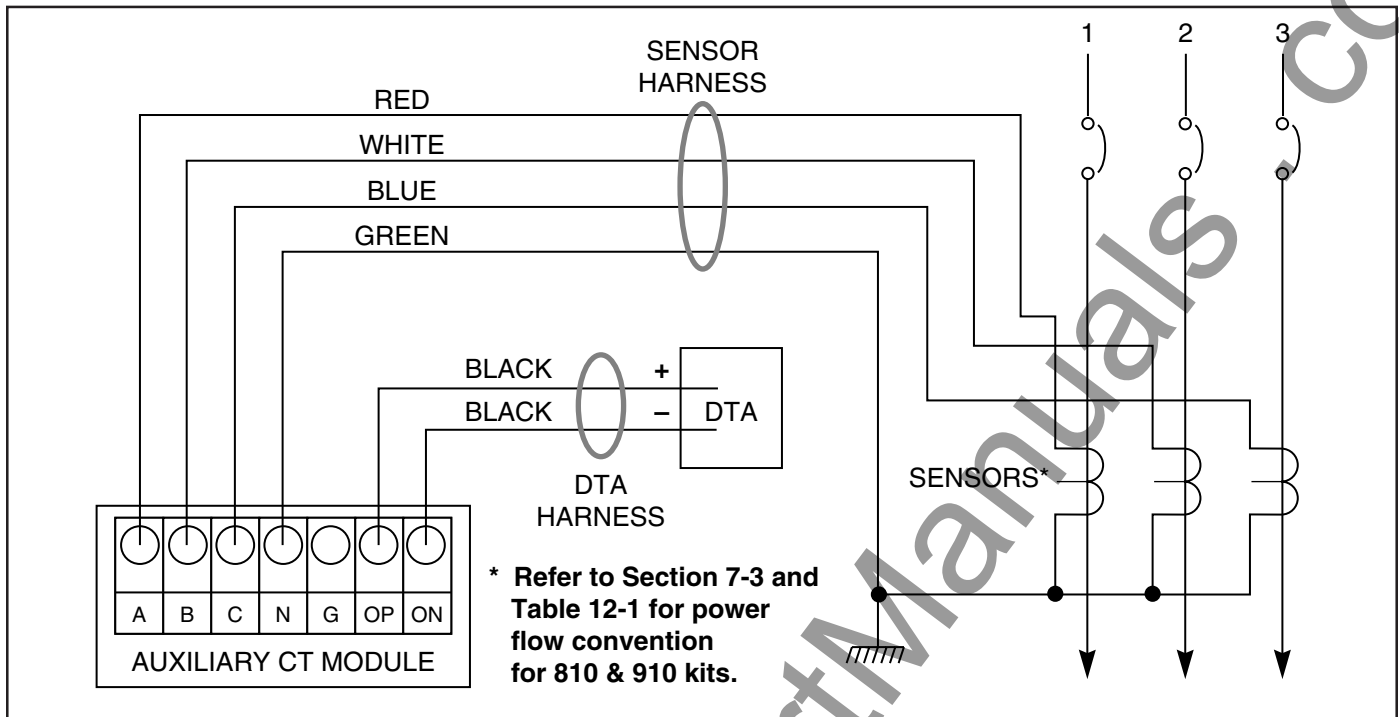

Fig. 12-1 Without Ground 3Ø 3-Wire (LI, LS, LSI)

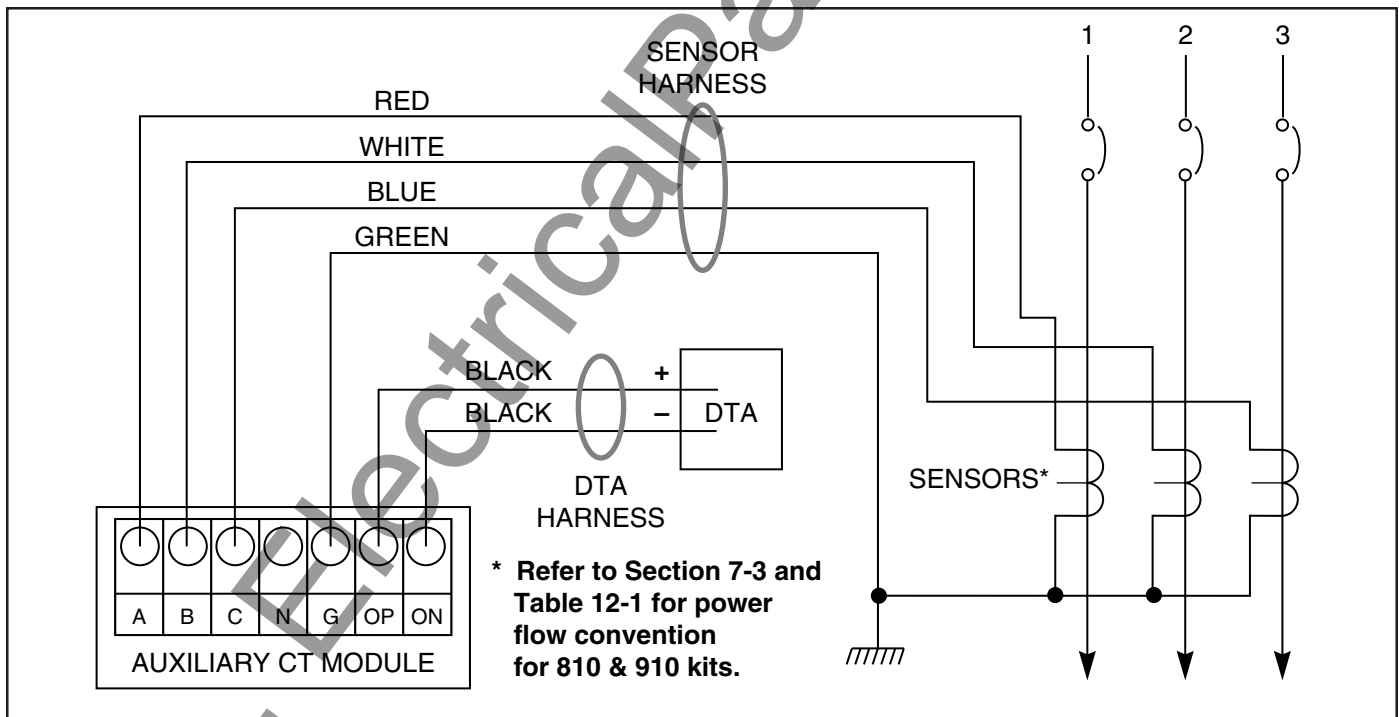

Fig. 12-2 With Ground, Without Neutral Connection 3Ø 3-Wire (LIG, LSG, LSIG)

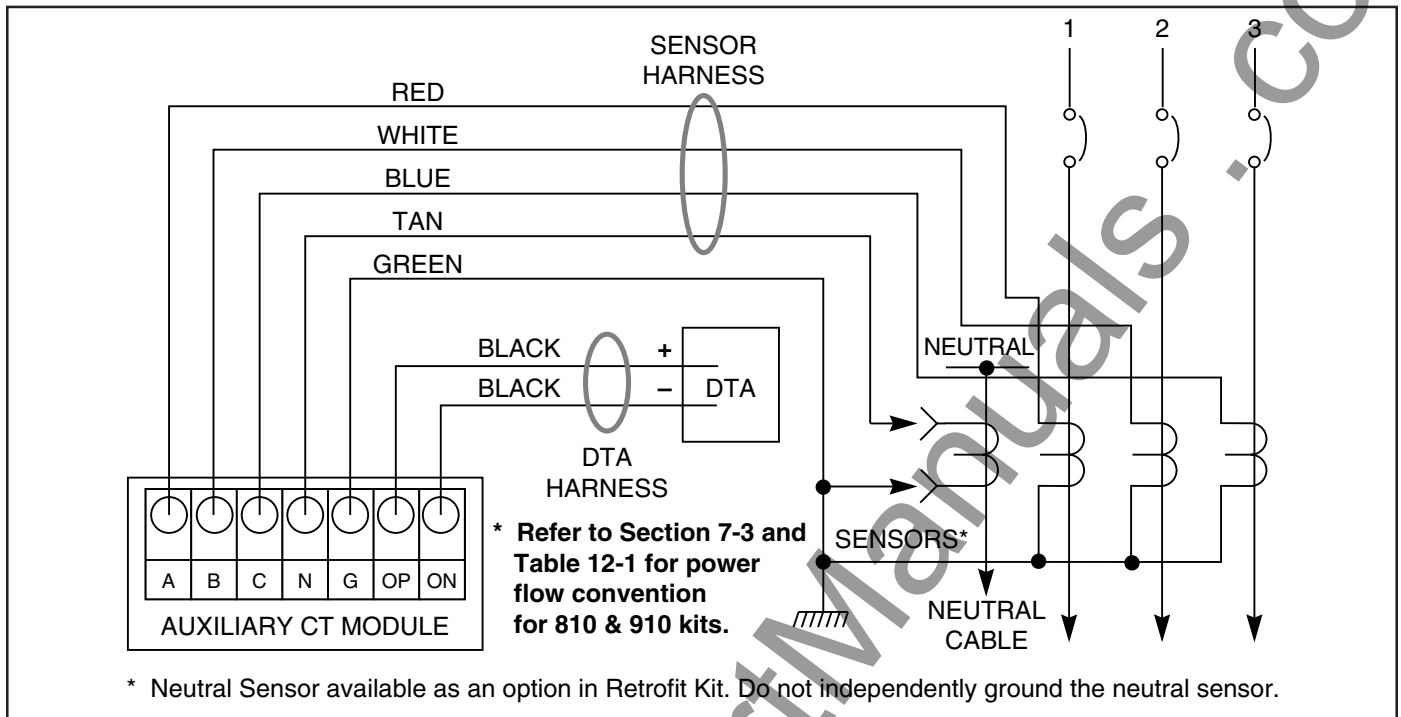

Fig. 12-3 With Ground and With Neutral Sensor 3Ø 4-Wire (LIG, LSG, LSIG)

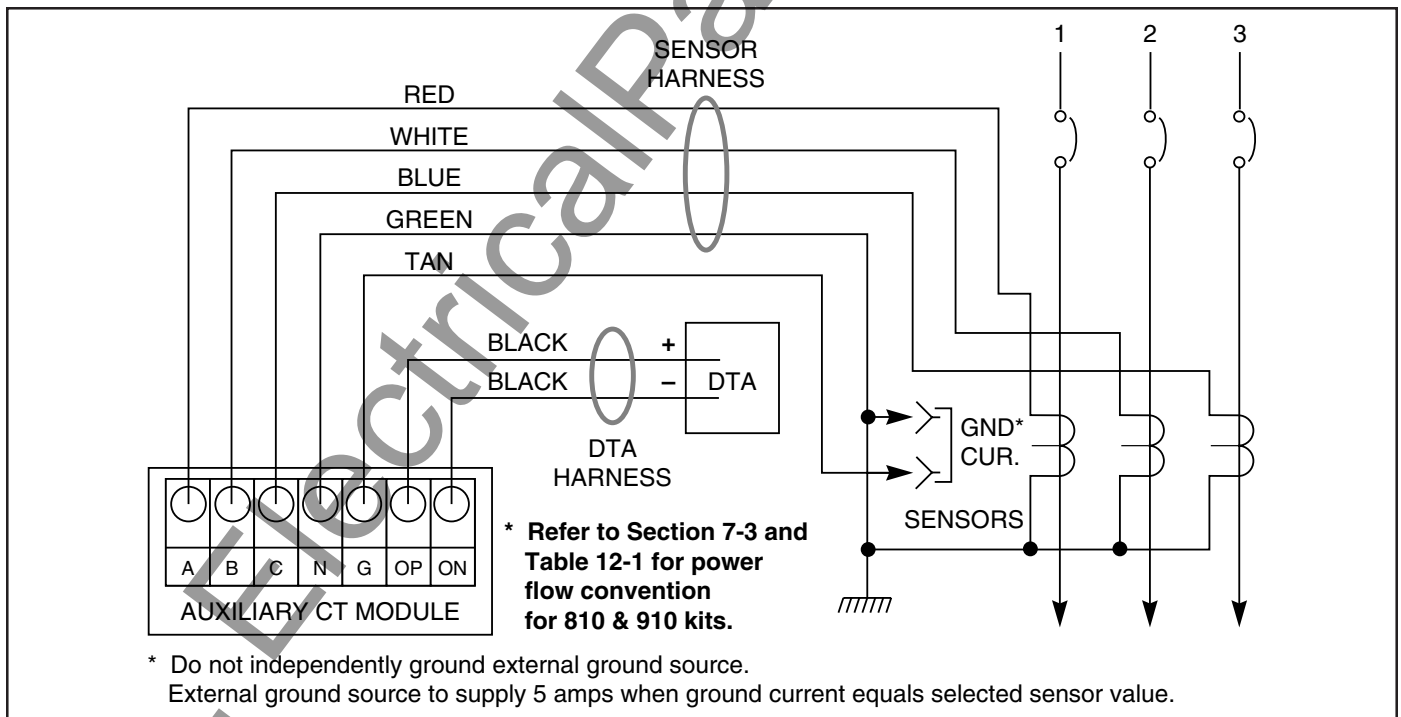

Fig. 12-4 With Ground, Without Neutral Connection 3Ø 3-Wire (LIG, LSG, LSIG)

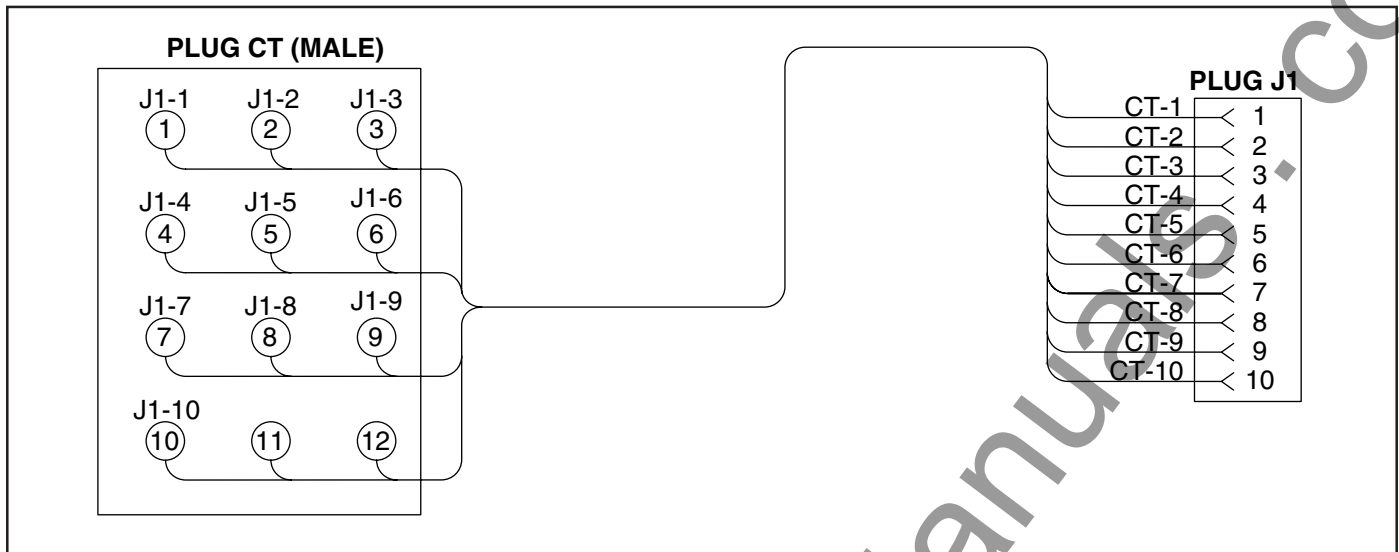

Fig. 12-5 Auxiliary CT Harness

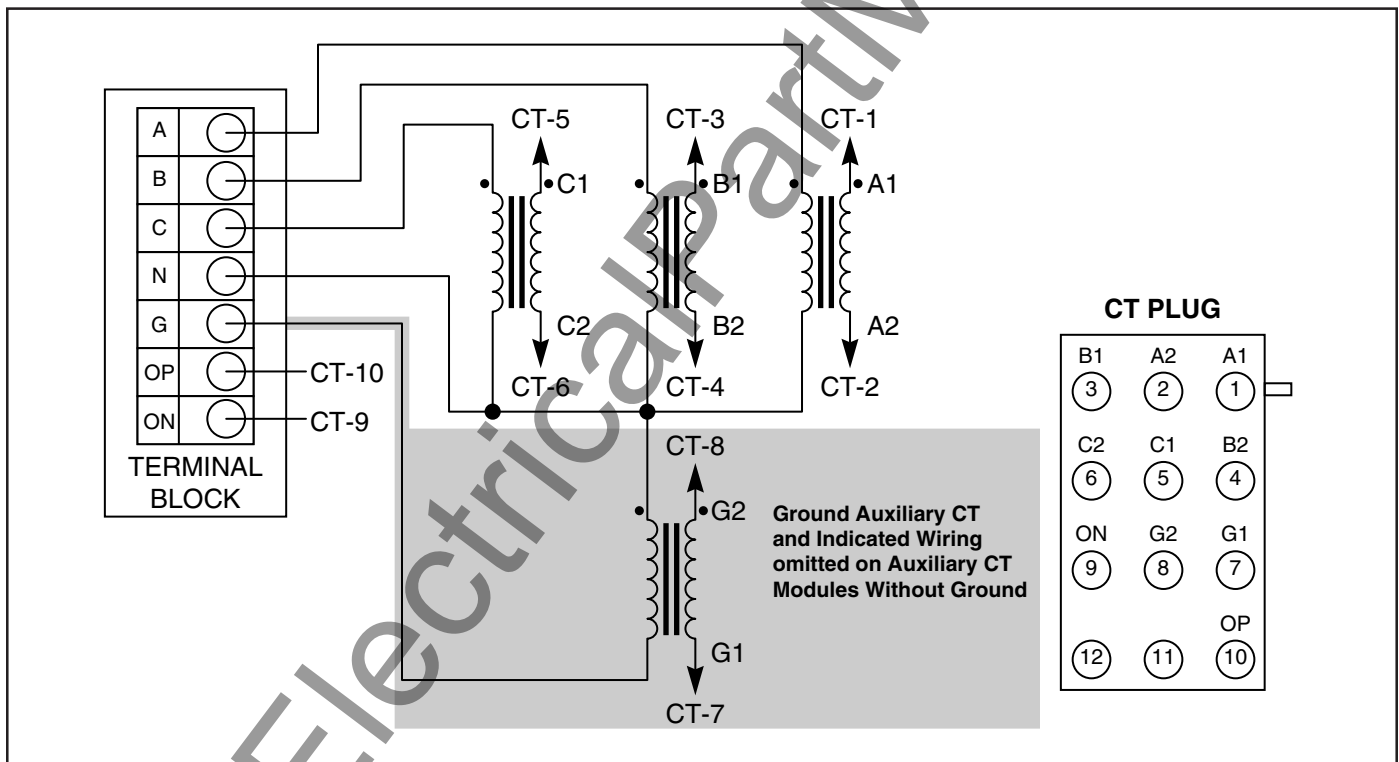

Fig. 12-6 Auxiliary CT Module Wiring

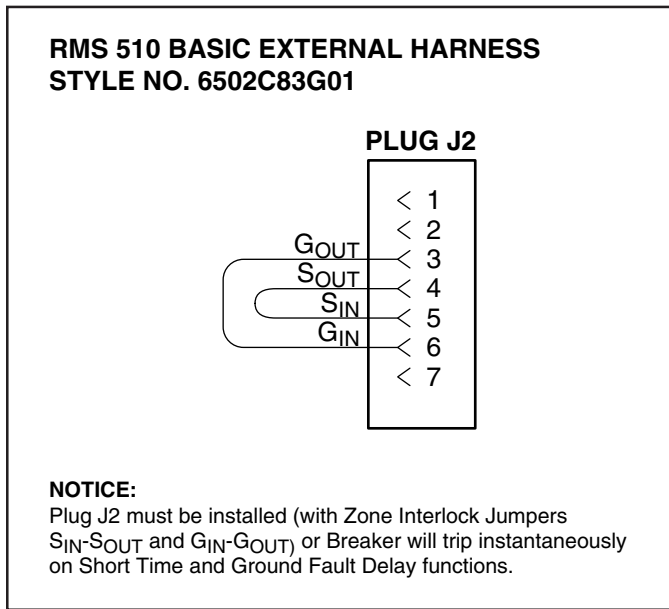

Fig. 12-7 Digitrip RMS 510 Basic External Harness

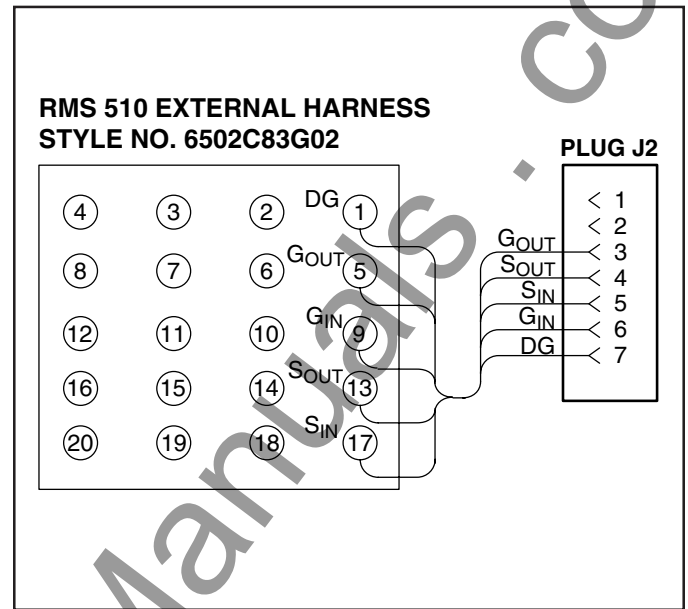

Fig. 12-8 Digitrip RMS 510 External Harness

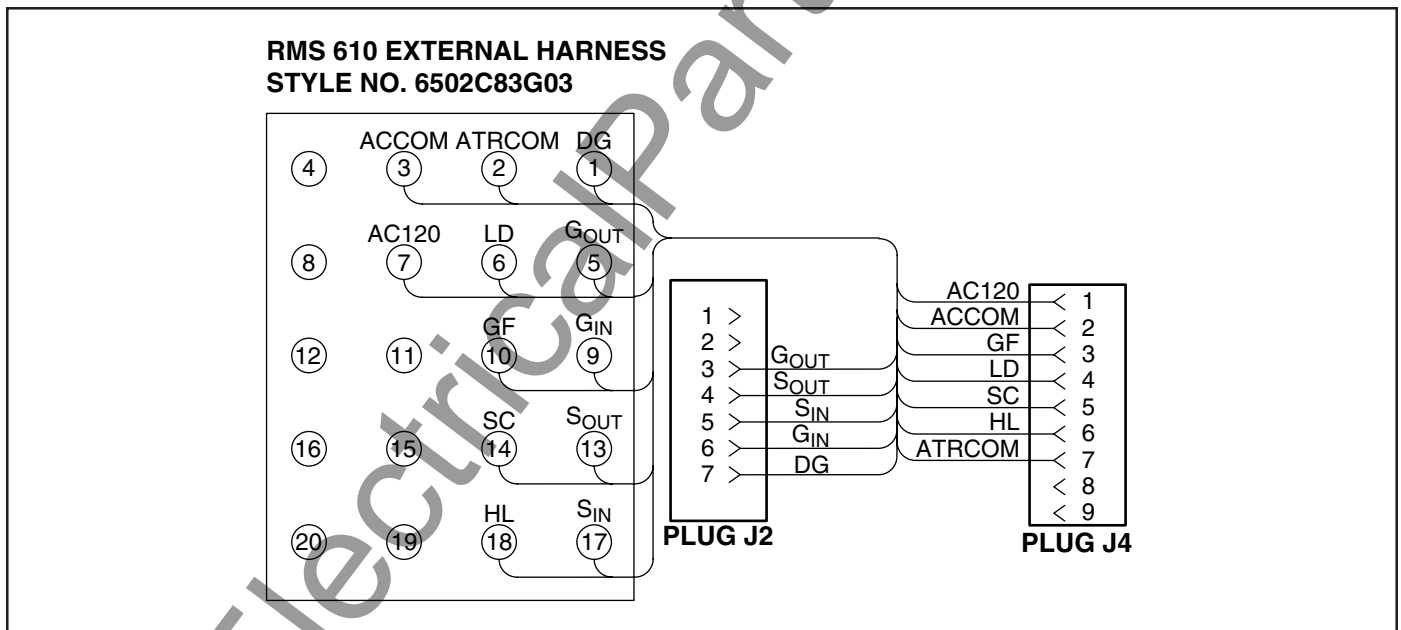

Fig. 12-9 Digitrip RMS 610 External Harness

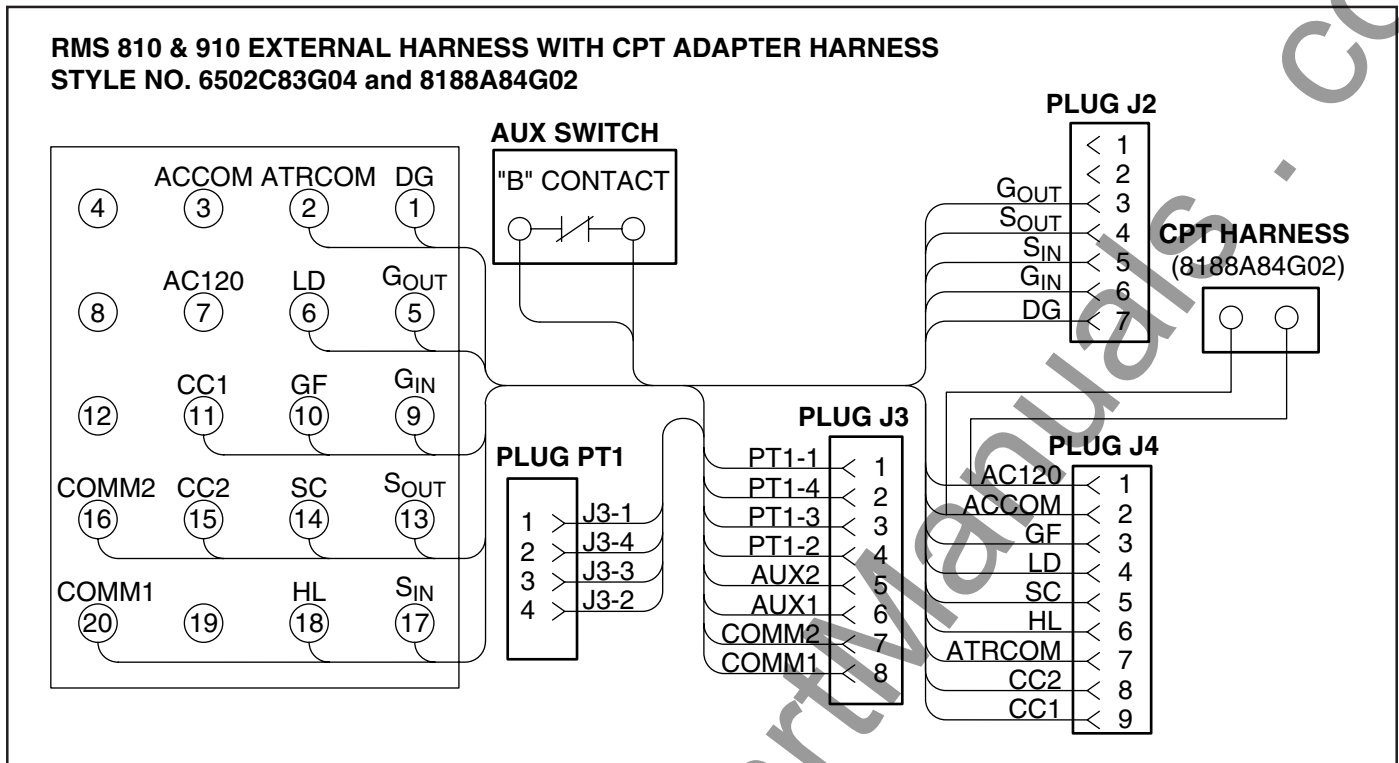

Fig. 12-10 Digitrip RMS 810 & 910 External Harness with CPT Adapter Harness

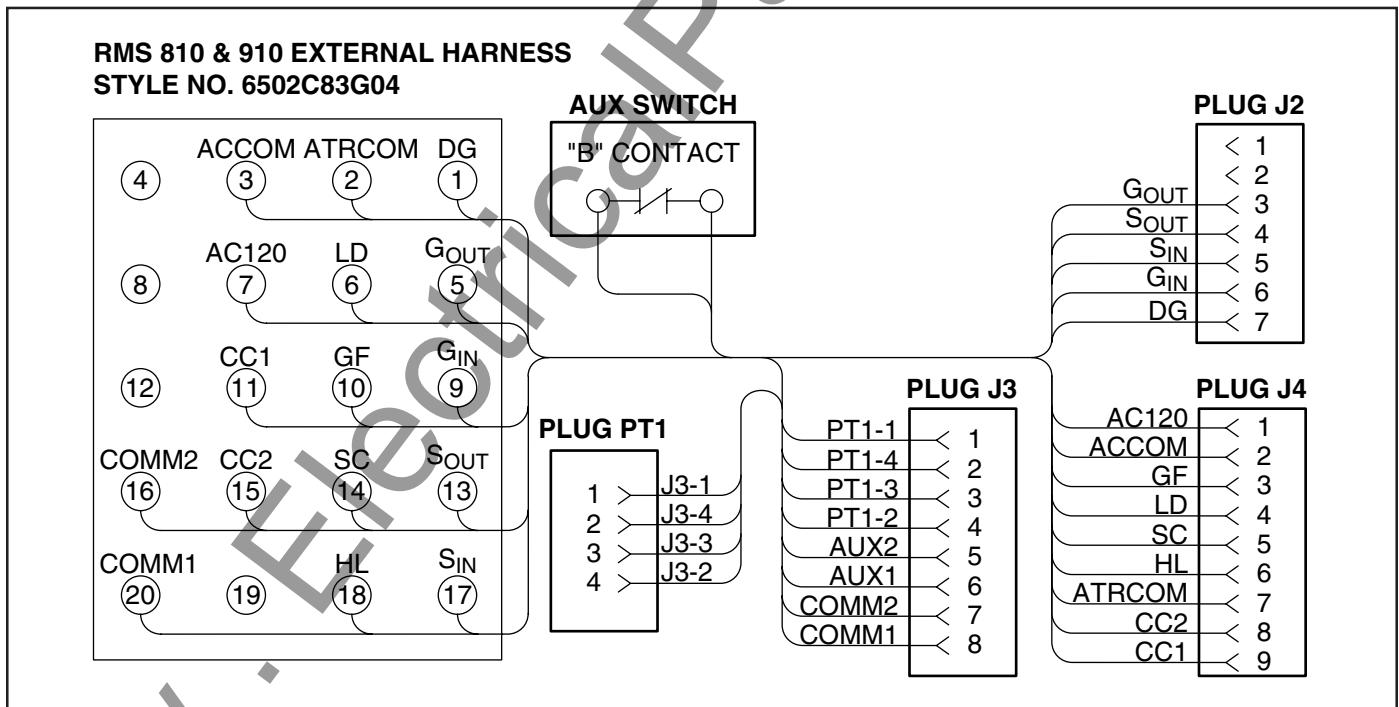

Fig. 12-11 Digitrip RMS 810 & 910 External Harness

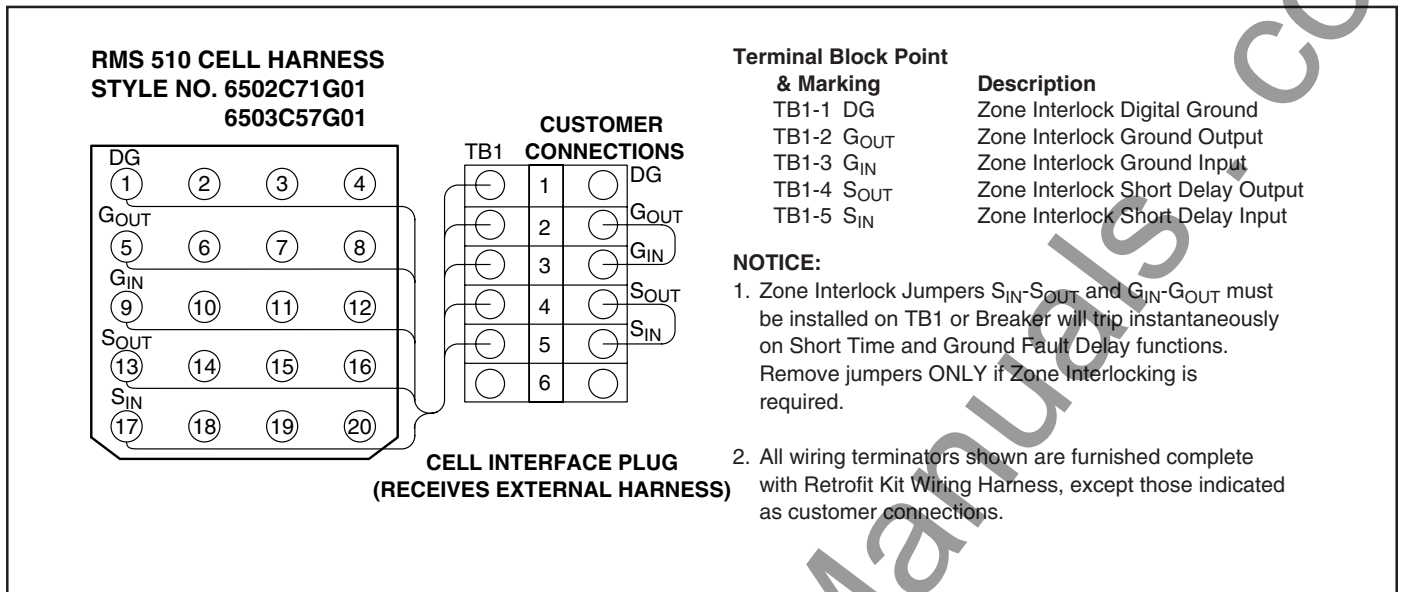

Fig. 12-12 Digitrip RMS 510 Cell Harness

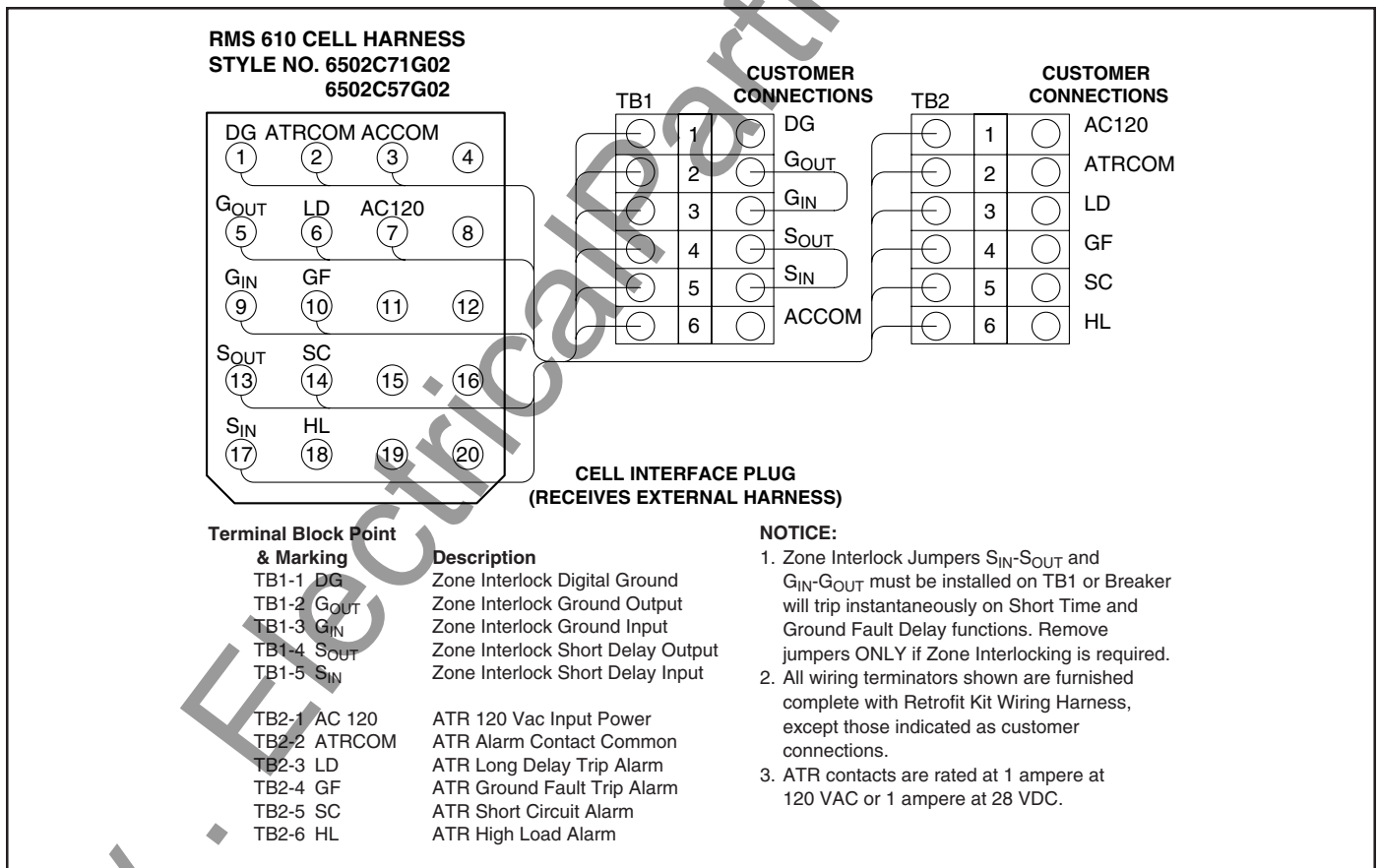

Fig. 12-13 Digitrip RMS 610 Cell Harness

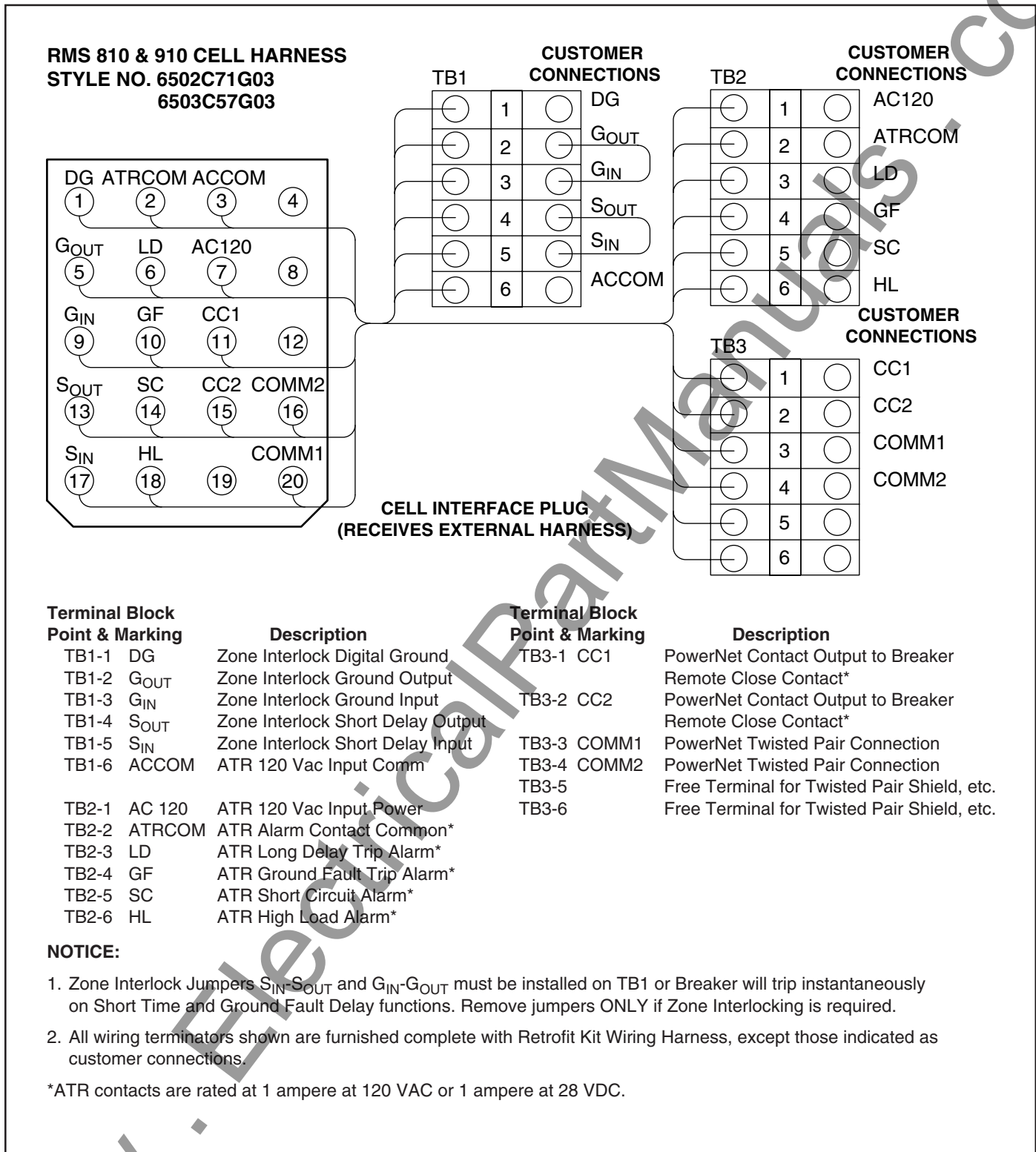

Fig. 12-14 Digitrip RMS 810 & 910 Cell Harness

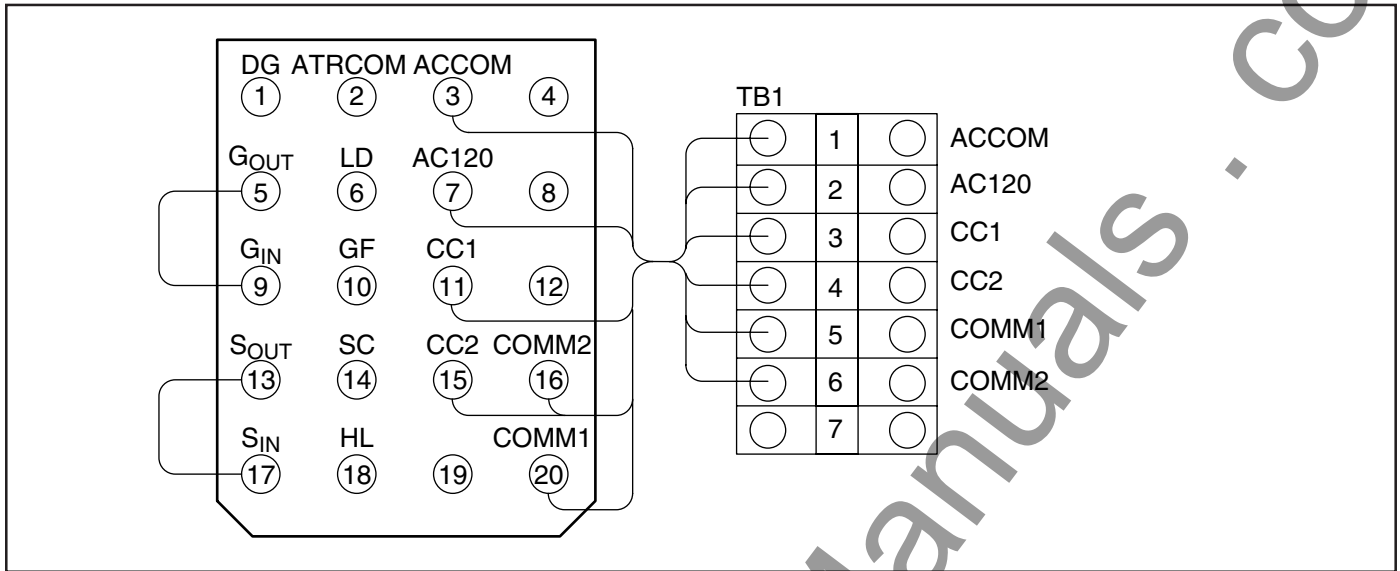

Fig. 12-15 Digitrip RMS 810 & 910 Simplified Cell Harness

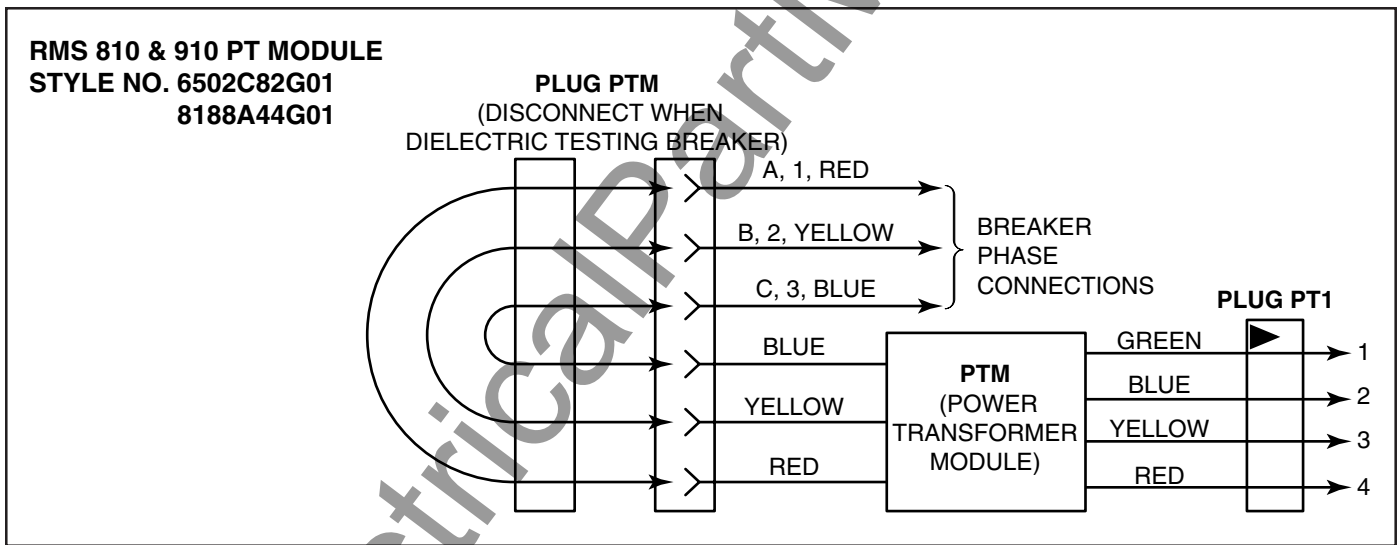

Fig. 12-16 Digitrip RMS 810 & 910 PT Module

Notes

www.ElectricalPartManuals.com

SECTION 13 REFERENCES

The listed documents are available references applicable to your Digitrip RMS Retrofit Kit installation.

- AD 29-862: Typical Time-current Characteristic Curve for Type SPB Systems Pow-r Breakers.
- AD 32-870: Characteristic Curves for DS Breakers with Digitrip RMS 510, 610, 810, & 910 Trip Units.
- IL 29-885: Instructions for Digitrip RMS 510 Trip Units.
- IL 29-886: Instructions for Digitrip RMS 610 Trip Units.
- IL 29-888: Instructions for Digitrip RMS 810 Trip Units.
- IL 29-889: Instructions for Digitrip RMS 910 Trip Units.

The instruction leaflets listed for the 10-Series Digitrip RMS Trip Units and for SPB System Breakers provide useful descriptive information that is also applicable to the 100-Series Digitrip RMS Trip Units.

This Application Data is used in conjunction with the Installation Literature for your particular Breaker application. A wide variety of Kits are available and new Breaker applications are an ongoing development effort. Contact Cutler-Hammer for the latest available Retrofit Kits.

If you wish to test the Trip Unit at the customer's settings, then we suggest Cutler-Hammer's Digitest software program, which will facilitate any combination of settings. Contact Cutler-Hammer at 1-800-937-5487 for information on the Digitest program.

Notes

www.ElectricalPartManuals.com

SECTION 14 EXPLANATION OF TIME CURRENT CURVES

14.1 Explanation of the Time Current Curves (LSI)

Digitrip RMS Trip Units and Digitrip Retrofit Kits have been designed to upgrade existing Breakers to meet the same protection requirements of the most modern Power Circuit Breakers. In fact, the Trip Unit and Direct Trip Actuator (DTA) are electrically identical to those found on current DS Breakers. They are built in the same manufacturing facilities, with the same high level of Quality Control, as those on the DS Breakers. In this way, we assure that the Retrofit Designs are as up to date as our current production.

All Digitrip RMS Trip Units are designed to meet the protection requirements of a modern power distribution system. As is shown in Figure 14-1, Application Current Levels can be broken into three typical regions:

- NORMAL currents, the magnitude of which is within the system continuous current rating;
- OVERLOAD currents, which exceed the system continuous current rating and where conductor heating is the primary concern (such as with an overloaded motor, for example);
- FAULT currents, which are usually caused by an unintended current path (either phase to phase or phase to ground) and can lead to currents as high as the maximum short circuit available from the system.

Digitrip RMS Trip Units, when set up according to the results of a Power System study of the specific distribution system on which they are applied, will respond to various current levels to provide accurate system protection as well as maximum system stability by properly coordinating with upstream and downstream devices (Figure 14-1).

- For NORMAL currents, the Trip Unit will accurately monitor the current, regardless of current waveform (due to its true RMS sensing system), assuring that up to full rated current may flow through the system without falsely tripping the breaker. This is shown as the NORMAL OPERATING CONDITION in Figure 14-1.
- For OVERLOAD currents, the Trip Unit will accurately assess the true heating value of the current (again a distinct advantage of its true RMS sensing system), and trip out following the LONG DELAY TRIP TIME curve in Figure 14-1. There are actually eight different LONG DELAY TRIP TIME curves available on the Trip Unit (selected by the Long Delay Time switch setting), and each curve follows a constant I^2t slope for excellent heating protection and coordination with other devices. The lowest level of OVERLOAD current to bring on this response is selected by the Long Delay Pickup setting on the Trip Unit.
- For FAULT currents, the Trip Unit will respond according to either the SHORT DELAY TRIP TIME or the INSTANTANEOUS TRIP TIME shown in Figure 14-1, depending on the fault current magnitude and whether the Short Delay function or Instantaneous function or both are present on the Trip Unit.

The SHORT DELAY TRIP TIME curve in Figure 14-1 shows the time to trip response of the Trip Unit to FAULT currents. There are actually eight different SHORT DELAY TRIP TIME curves available on the Trip Unit (selected by the Short Time switch setting), three of which follow a constant I^2t slope for best coordination with downstream devices, five of which are FLAT (fixed trip time). The lowest level of FAULT current to bring on this response is selected by the Short Delay Pickup setting on the Trip Unit.

The SHORT DELAY TRIP TIME curves available on the Trip Unit (selected by the Short Time switch setting), can also be modified by a feature of the Digitrip RMS system called ZONE SELECTIVE INTERLOCKING.

The INSTANTANEOUS TRIP TIME curve in Figure 14-1 shows the time to trip response of the Trip Unit to FAULT currents. This curve is FLAT, providing the most rapid trip time possible (with no intentional delay) to be able to clear the fault as fast as possible and minimize the damage to the system. The lowest level of FAULT current to bring on this response is selected by the Instantaneous Pickup setting on the Trip Unit.

In most applications, main Breakers will have Long Delay and Short Delay functions, but will omit the Instantaneous function to allow a downstream feeder Breaker to clear the fault without tripping the main Breaker, thereby enhancing system stability.

In many applications, feeder Breakers will have Long Delay, Short Delay, and Instantaneous functions to allow a downstream device to clear the fault without tripping the feeder or the main Breaker, thereby maximizing system stability.

In some applications, feeder Breakers will have Long Delay and Instantaneous functions, but omit the Short Delay function. This is fine for coordination with upstream main Breakers, but the feeder would not normally allow a downstream device to clear the fault without tripping the feeder, thereby compromising the system stability.

In some applications, feeder Breakers will have Long Delay and Short Delay functions, but will omit the Instantaneous function to allow proper operation of an unusual load or coordination with downstream devices.

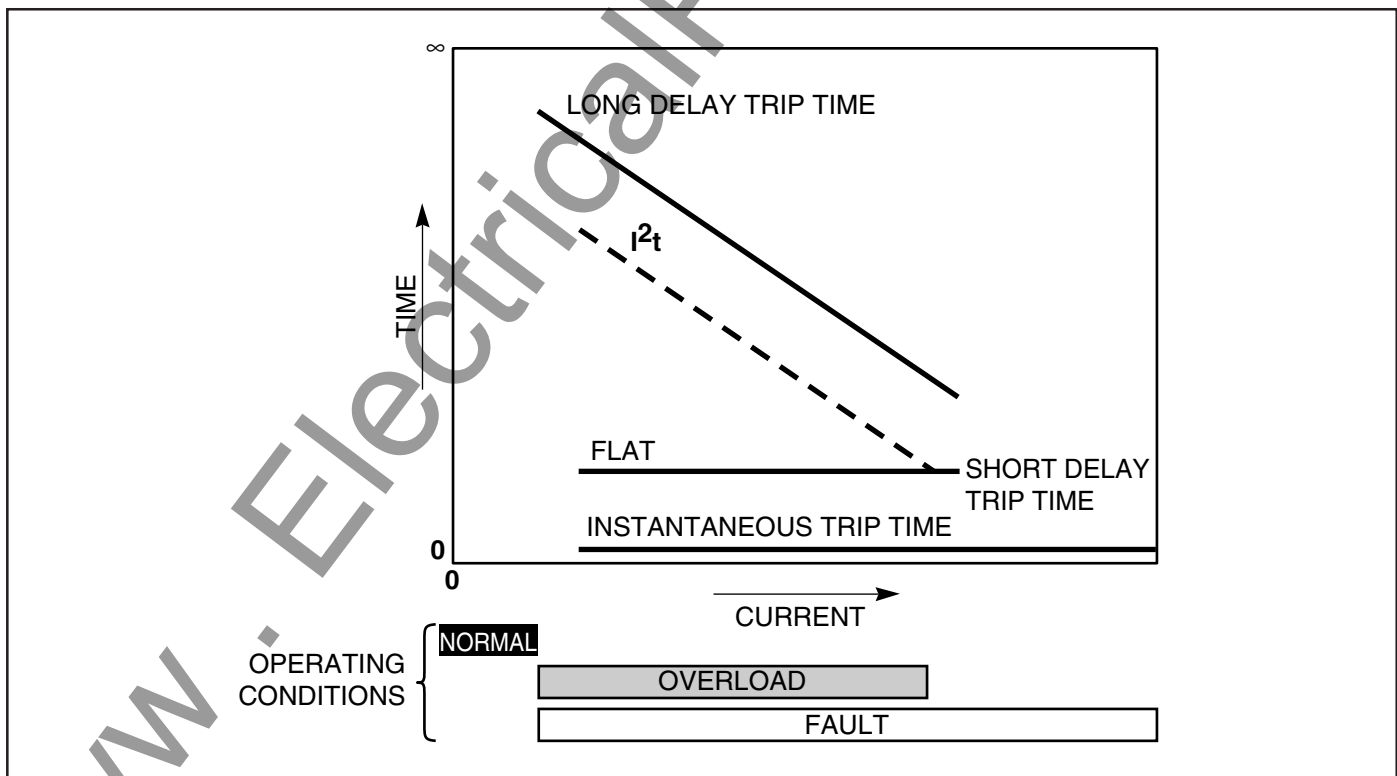

Fig. 14-1 Time-Current Curves

www.ElectricalPartManuals.com

We wish to thank you for purchasing the Digitrip Retrofit System. Digitrip Retrofit Kits are designed and manufactured in America with pride. All the components are engineered to fit the existing Circuit Breaker with little or no modifications to the existing Breaker. However due to the wide variety and vintage of Breakers in use today, an occasional problem may arise. Please contact us with any questions, comments or concerns.

Phone: **1-800-937-5487** Fax: (724) 779-5899

The information, recommendations, descriptions, and safety notations in this document are based on Cutler-Hammer's experience and judgement with respect to retrofitting of power breakers. This information should not be considered to be all inclusive or covering all contingencies. If further information is required, Cutler-Hammer should be consulted.

NO WARRANTIES, EXPRESSED OR IMPLIED, INCLUDING WARRANTIES OF FITNESS FOR A PARTICULAR PURPOSE OR MERCHANTABILITY, OR WARRANTIES ARISING FROM COURSE OF DEALING OR USAGE OF TRADE, ARE MADE REGARDING THE INFORMATION, RECOMMENDATIONS AND DESCRIPTIONS CONTAINED HEREIN. In no event will Cutler-Hammer be responsible to the user in contract, in tort (including negligence), strict liability or otherwise, for any special, indirect, incidental, or consequential damage or loss whatsoever, including but not limited to damage to or loss of use of equipment, plant or power system, cost of capital, loss of profits or revenues, cost of replacement power, additional expenses in the use of existing power facilities, or claims against the user by its customers resulting from the use of the information, recommendations, and descriptions contained herein.

Cutler-Hammer

Pittsburgh, Pennsylvania U.S.A.

Publication No. AD 33-855-2
February 2000
Printed in U.S.A./TBG00001

EAT•N