



Digitrip Retrofit System for Federal Pioneer 50 / 65 H-2 Breakers



SAFETY PRECAUTIONS

WARNING

POWER CIRCUIT BREAKERS ARE EQUIPPED WITH HIGH SPEED, HIGH ENERGY OPERATING MECHANISMS. THE BREAKERS AND THEIR ENCLOSURES ARE DESIGNED WITH SEVERAL BUILT-IN INTERLOCKS AND SAFETY FEATURES INTENDED TO PROVIDE SAFE AND PROPER OPERATING SEQUENCES. TO PROVIDE MAXIMUM PROTECTION FOR PERSONNEL ASSOCIATED WITH THE INSTALLATION, OPERATION, AND MAINTENANCE OF THESE BREAKERS, THE FOLLOWING PRACTICES MUST BE FOLLOWED. FAILURE TO FOLLOW THESE PRACTICES MAY RESULT IN DEATH, PERSONAL INJURY, OR PROPERTY DAMAGE.

- Only qualified persons, as defined in the National Electric Code, who are familiar with the installation and maintenance of power circuit breakers and their associated switchgear assemblies should perform any work associated with these breakers.
- Completely read and understand all instructions before attempting any installation, operation, maintenance, or modification of these breakers.
- **Always turn off and lock out the power source feeding the breaker prior to attempting any installation, maintenance, or modification of the breaker. Do not use the circuit breaker as the sole means for isolating a high voltage circuit. Follow all lockout and tagging rules of the National Electric Code and all other applicable codes, regulations, and work rules.**
- Do not work on a closed breaker or a breaker with the closing springs charged. Trip (open) the breaker and be sure the stored energy springs are discharged before performing any work. The breaker may trip open or the charging springs may discharge, causing crushing or cutting injuries.



- For drawout breakers, trip (open), and then remove the breaker to a well-lit work area before beginning work.
- Do not perform any maintenance: including breaker charging, closing, tripping, or any other function which could cause significant movement of the breaker while it is on the extension rails. Doing so may cause the breaker to slip from the rails and fall, potentially causing severe personal injury to those in the vicinity.
- **Do not leave the breaker in an intermediate position in the switchgear cell. Always leave it in the connected, disconnected, or (optional) test position. Failure to do so could lead to improper positioning of the breaker and flashover, causing death, serious personal injury, and / or property damage.**
- **Do not defeat any safety interlock. Such interlocks are intended to protect personnel and equipment from damage due to flashover and exposed contacts. Defeating an interlock could lead to death, severe personal injury, and / or property damage.**



Digitrip Retrofit System for Federal Pioneer 50 / 65 H-2 Breakers

CONTENTS

Description

- Introduction 5
- Step 1: General Breaker Preparation 6
- Step 2: Removing the Original Components and Preparing the Breaker for Retrofitting 7
- Step 3: Installing the Sensors and Sensor Harness (Partial) 8
- Step 4: Preparing the Aux. CT Assembly 11
- Step 5: Installing the Breaker Mounted CPT 13
- Step 6: Installing the Trip Finger 19
- Step 7: Installing the DTA 21
- Step 8: Installing the Aux. CT Module Assembly and the Trip Unit 24
- Step 9: Installing the External Harness and Final Wiring 27
- Step 10: Testing the Breaker 29
- Step 11: Mounting the Cell Harness 30
- Step 12: Installing the Retrofitted Breaker in the Cell 30

Figures

- 1. Overview: Original Components Removed from the Breaker and Saved for Reinstallation. 7
- 2. Hood Assembly, Arc Chutes, Flash Barrier, Interphase Barriers, and Side Barriers Removed from the Breaker. 7
- 3. Charging Handle, Face Plate, and Floating Trim Removed from the Breaker. 8

- 4. Overview: Sensors Installed in the Breaker. . 8
- 5. Finger Clusters Removed from the Bottom Load Terminals (Electrically Operated). 8
- 6. Lower Molding and Load Terminals Removed from the Breaker. 9
- 7. Sensor and Spacers Installed on a Jumper. . 9
- 8. Sensors, Load Terminals, and Lower Molding Installed on the Breaker. 10
- 9. Finger Clusters Reinstalled on the Load Terminals (Electrically Operated). 10
- 10. Sensor Harness Connected to the Sensors. 10
- 11. Routing of the Sensor Harness. 11
- 12. Overview: Aux. CT Assembly and PT Module Ready for Installation. 11
- 13. Glass Poly Barrier Mounted to the Aux. CT Module. 11
- 14. PT Module Mounted to the Aux. CT Module Assembly. 12
- 15. Aux. CT Module Assembly Placed on the Breaker Frame. 12
- 16. PT Wires Connected to the Jumper Bolts. . 12
- 17. PT Wires Secured to the Sensor Harness. . 13
- 18. Overview: Breaker Mounted CPT Installed in the Breaker. 13
- 19. Fuse Clips and Spade Connector Removed from the CPT 13
- 20. CPT Module Installed on the Mounting Bracket. 14
- 21. Drilling Plan "A". 14
- 22. Load and Line Sides of the HV Wires. 14

INTRODUCTION

Cutler-Hammer Digitrip Retrofit Kits are available in a number of configurations that provide a wide range of features. The Digitrip System starts with the 510 Basic Kit which offers true RMS sensing, overcurrent protection, and self-testing features. Advanced Digitrip Retrofit Kits feature zone interlocking, digital alphanumeric displays, remote alarm signals, PowerNet communications, energy monitoring capabilities, power factors, and harmonic content measurements.

Table 1 provides a quick reference of the components supplied with each level of Retrofit Kit. Before beginning the Retrofit process, take a minute to review the information contained in Table 1. It is important that the Retrofitter understands which

level of Retrofit Kit is to be installed and which components are included with the Kit.

The instructions contained in this manual cover the installation of all levels of Retrofit Kit. If the Kit you are installing does not contain a certain component, skip the instructions for that component and proceed to the next.

Throughout the Retrofit process, refer to the Torque Tables at the back of this manual for specific torque values.

If you have any questions concerning the Retrofit Kit and / or the Retrofit process, contact Cutler-Hammer at: 1-800-937-5487.

Table 1 Available Retrofit Kits

Components	510 Basic	510 with Zone Interlock	610	810	910
Trip Unit					
Rating Plug					
Auxiliary Current Transformer (CT) Module					
Auxiliary CT Harness					
Sensors					
Sensor Harness					
Direct Trip Actuator (DTA)					
Mounting Brackets and Hardware					
External Harness	Plug	1 Connector Harness	2 Connector Harness	4 Connector Harness	4 Connector Harness
Cell Harness					
Breaker Mounted Control Power Transformer (CPT)					
Potential Transformer (PT) Module					
Auxiliary Switch					

STEP 1: GENERAL BREAKER PREPARATION

Before attempting to remove the Breaker from the Cell or perform any Retrofit Operation, be sure to read and understand the Safety Precautions section of this manual. In addition, be sure to read and understand the Instructions for the Application of Digitrip RMS Retrofit Kits on Power Circuit Breakers (Retrofit Application Data - Publication AD 33-855-3), supplied with the Digitrip Retrofit Kit.



WARNING

DO NOT ATTEMPT TO INSTALL OR PERFORM MAINTENANCE ON EQUIPMENT WHILE IT IS ENERGIZED. SEVERE PERSONAL INJURY OR DEATH CAN RESULT FROM CONTACT WITH ENERGIZED EQUIPMENT. VERIFY THAT NO VOLTAGE IS PRESENT BEFORE PROCEEDING.

- A. Trip the Breaker and remove it from the Cell.
Move the Breaker to a clean, well-lit work area.

NOTE: It is the responsibility of the Retrofitter to insure that the Breaker and all original components are in good condition. Visually inspect all Breaker components for signs of damage or wear. If any signs of damage or wear are detected for components not included in the Retrofit Kit, secure the necessary replacement parts before beginning the Retrofit Process.

The force necessary to trip the Breaker should not exceed three (3) lbs.

NOTE: It is the responsibility of the Retrofitter to insure that the proper, manufacturer's recommended crimping tools and terminals are used for each type of connector. It is also the responsibility of the Retrofitter to insure that all wire preparations, connections, strippings, terminations, and wiring techniques are performed according to the latest IEEE, NEC, and / or NEMA industry standards, specifications, codes, and guidelines.

To begin the Retrofit Process, refer to the components list at the end of this manual. Layout the components and hardware according to the steps outlined. The parts bags are labeled with the corresponding step number. The components and hardware will be used to complete each step in the Retrofit Process.

STEP 2: REMOVING THE ORIGINAL COMPONENTS AND PREPARING THE BREAKER FOR RETROFITTING

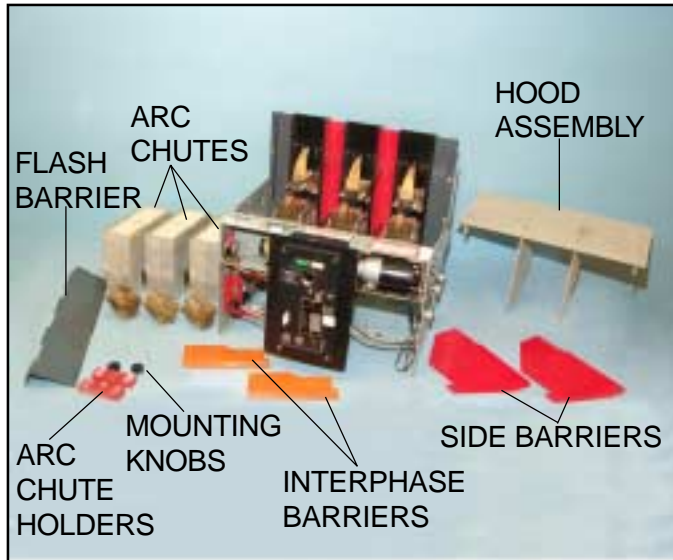

Fig. 1 Overview: Original Components Removed from the Breaker and Saved for Reinstallation.

NOTE: Throughout this Retrofit, an electrically operated Breaker was used for the support photographs. Where the components and / or procedures differ between the electrically and mechanically operated Breakers, photos of both are supplied for clarity.

NOTE: The Breakers Retrofitted in the creation of this IL had 21" wide Frames. If the Breaker being Retrofitted is either narrower or wider, exact locations for drilling any mounting holes must be confirmed before drilling. The locations may not match the Drilling Plans contained in this IL.

Refer to the Federal Pioneer 50 / 65 H-2 Instruction Manual, originally supplied with the Breaker, to perform the following procedures.

- A. Remove and discard the original Trip Unit and all associated wiring and mounting hardware.
- B. Remove and save the Hood Assembly.
- C. Remove the Mounting Knobs and Arc Chute Holders securing the Arc Chutes to the Breaker. Remove and save the Arc Chutes, the Holders, and the Mounting Knobs.
- D. Remove and save the two (2) Side Barriers.
- E. Remove the mounting hardware securing the Flash Barrier to the Breaker. Remove and save the Flash Barrier and the mounting hardware.
- F. Remove and save the Phase 1 & 2 and Phase 2 & 3 Interphase Barriers.



Fig. 2 Hood Assembly, Arc Chutes, Flash Barrier, Interphase Barriers, and Side Barriers Removed from the Breaker.

NOTE: Removing the Charging Handle, Breaker Face Plate, and the Floating Trim detailed in Steps "G" and "H" below, are not mandatory for the Retrofit. However, removing these components will provide additional access to the internal Breaker mechanisms during the Retrofit.

- G. Remove and save the Charging Handle.
- H. Remove the hardware securing the Breaker Face Plate to the Breaker. Remove and save the Face Plate, Floating Trim, and mounting hardware.



Fig. 3 Charging Handle, Face Plate, and Floating Trim Removed from the Breaker.

STEP 3: INSTALLING THE SENSORS AND SENSOR HARNESS (PARTIAL)

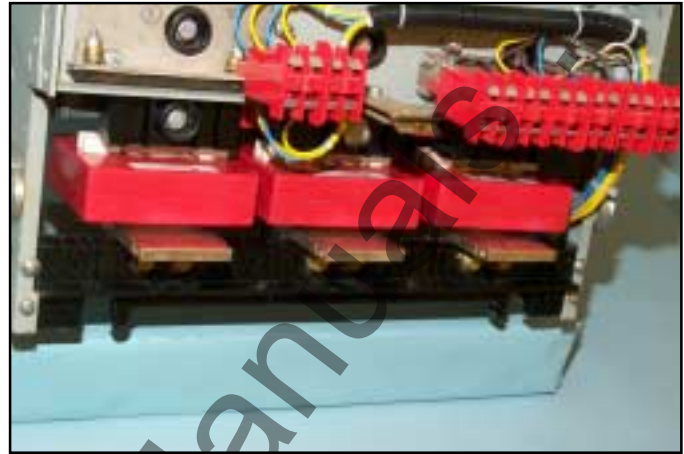

Fig. 4 Overview: Sensors Installed in the Breaker.

Refer to the Federal Pioneer 50 / 65 H-2 Instruction Manual, originally supplied with the Breaker, to perform the following procedures.

- A. Remove the hardware securing the Finger Clusters (Drawout Contacts) to the bottom Load Terminals. Remove and save the Finger Clusters and mounting hardware.
- B. Raise the rear of the Breaker approximately four (4) inches to provide clearance for the following steps.



Fig. 5 Finger Clusters Removed from the Bottom Load Terminals (Electrically Operated).

- C. Loosen the six (6) bolts and nuts securing the rear Lower Molding and Load Terminals to the Jumpers.
- D. Remove and save the mounting hardware securing the Lower Molding to the right and left sides of the Breaker.
- E. While "spreading" the sides of the Breaker, remove the Lower Molding and Load Terminals from the Breaker. Note that as you are removing the Lower Molding, the Load Terminals will fall free.
- F. Remove the original Sensors from the Jumpers. Scrap the original Sensors and all associated wiring.



Fig. 6 Lower Molding and Load Terminals Removed from the Breaker.

- G. Install a new Sensor and two (2) spacers, as shown, on each Jumper. Note that the Sensors must be installed with the terminals towards the inside of the Breaker. The combination of the Sensors and spacers create a "friction fit" to hold the Sensors in place.



Fig. 7 Sensor and Spacers Installed on a Jumper.



- H. To reinstall the Lower Molding, align the Load Terminals with the holes in the Lower Molding. Insert the bolts into the Lower Molding and Load Terminals and thread two (2) to three (3) turns to keep the Load Terminals in place.

Insert the right side of the Lower Molding into position with the right side of the Breaker (when viewed from the rear). While "spreading" the left side of the Breaker, push the left side of the Lower Molding into place.

- I. Using the original mounting hardware removed in Step 3-D, secure the Lower Molding to the Breaker.
- J. Tighten the six (6) original bolts and nuts until the Load Terminals are securely mated to the Jumpers.

For Kits Supplied with a PT Module Only:
Leave one (1) nut loose on each Load Terminal. These will be used later in the Retrofit Process to secure the PT Wires.

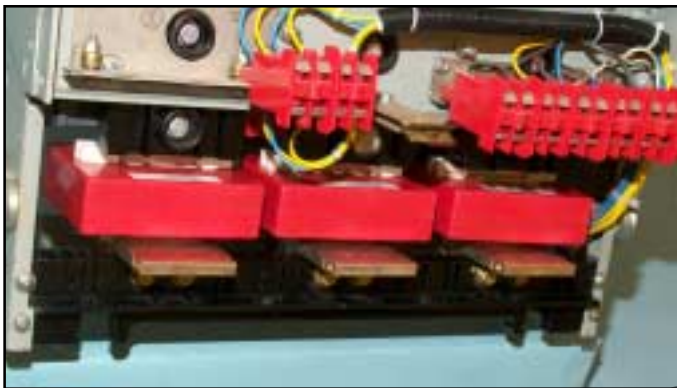

Fig. 8 Sensors, Load Terminals, and Lower Molding Installed on the Breaker.

- K. Using the original mounting hardware, reinstall the bottom Finger Clusters on the Load Terminals in their original positions.



Fig. 9 Finger Clusters Reinstalled on the Load Terminals (Electrically Operated).

- L. Remove what was used to elevate the back of the Breaker and return the Breaker to its rest position.
- M. Working from the front of the Breaker, connect the ring terminals of the Sensor Harness to the Sensor Terminals. Refer to Section 12 of the Application Data, supplied with the Retrofit Kit, for detailed wiring specifications.

For FP 50 / 65 H-2 Retrofits, the following conventions apply.

Table 2 Sensor Taps Rating

Sensor Style No.	Terminal Com.	Amps
9A10020H01	X1 - X2 =	800 A
	X1 - X3 =	1,600 A
9A10021H01	X1 - X2 =	1,200 A
	X1 - X3 =	2,000 A



Fig. 10 Sensor Harness Connected to the Sensors.

- N. Route the Sensor Harness along the back of the Breaker towards the left side. Use the self-adhesive mounting pads and wire ties supplied to secure the Sensor Harness away from any moving parts within the Breaker.

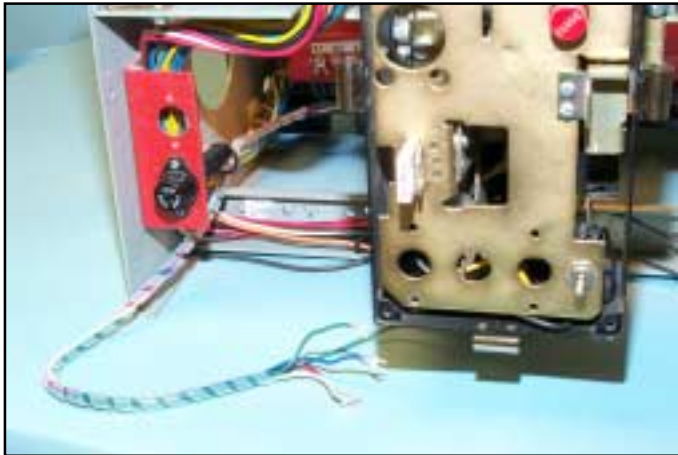

Fig. 11 Routing of the Sensor Harness.

STEP 4: PREPARING THE AUX. CT ASSEMBLY



Fig. 12 Overview: Aux. CT Assembly and PT Module Ready for Installation.

- A. Align the Glass Poly Barrier with the existing holes in the back of the Aux. CT Module as shown. Secure the Barrier to the Aux. CT Module using the using the (2) .190-32 x .375" screws, (2) lock washers, and (2) flat washers supplied.

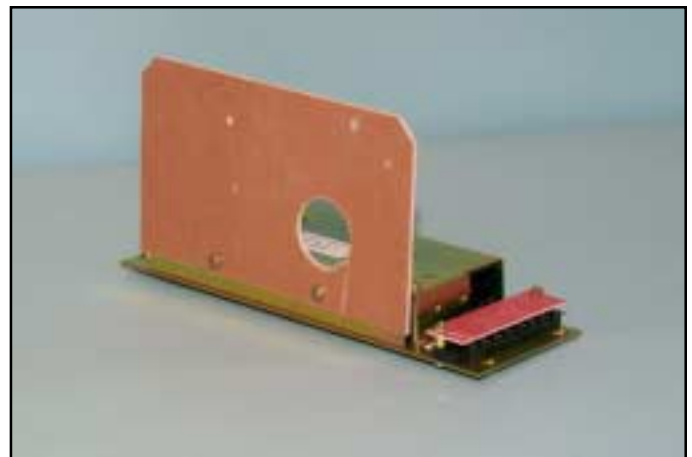

Fig. 13 Glass Poly Barrier Mounted to the Aux. CT Module.

For Kits Supplied with a PT Module Only.

- B. Align the PT Module with the existing holes in the Glass Poly Barrier as shown. Secure the PT Module to the Glass Poly Barrier using the (2) .138-32 x .500" screws, (4) flat washers, (2) lock washers, and (2) nuts supplied.



Fig. 14 PT Module Mounted to the Aux. CT Module Assembly.

NOTE: To ease installation, the PT Wires will be connected to the Jumpers in the following steps. To accomplish this, the Aux. CT Module Assembly must be set on the top of the Breaker Frame. Until the Aux. CT Module Assembly is mounted later in the Retrofit Process, care must be taken to insure that the Aux. CT Module Assembly is not "knocked off" the Breaker.

C. Set the Aux. CT Module Assembly on the top of the Breaker Frame.

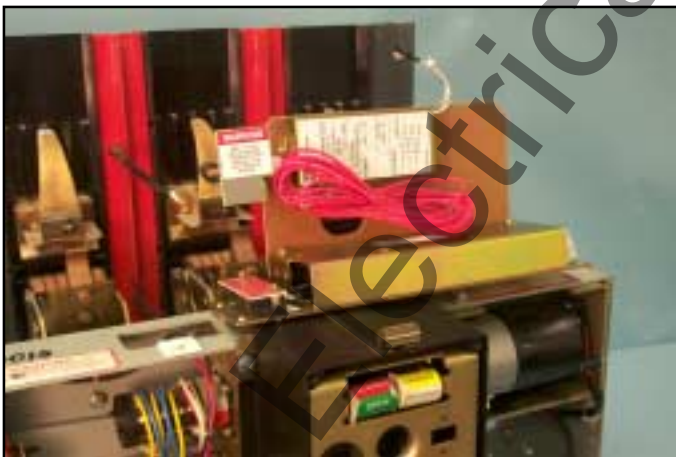

Fig. 15 Aux. CT Module Assembly Placed on the Breaker Frame.

D. Route the PT Wires through the cut-out in the top and middle Breaker Frames, down towards the bottom left rear corner of the Breaker.

E. The PT Wires are marked for connection to Phases 1, 2, and 3 with corresponding numbers.

NOTE: Before cutting the PT Wires, verify the Phase Convention used on the Breaker Application.

Route the PT Wires to a position suitable for attachment to the bolts that secure the Load Terminals to the Jumpers. These were left loose in Step 3. Move the PT Wire markers to a position where they will still be attached to the wires after cutting. Cut the wires to the appropriate length, strip each wire .250", and install a .500" ring terminal on each wire. Remove the nuts and washers from the Jumper bolts left loose in Step 3-J. Using the hardware just removed, connect the PT Wires to the Jumpers.



Fig. 16 PT Wires Connected to the Jumper Bolts.

F. Use the wire ties supplied to secure the PT Wires to the Sensor Harness running along the inside of the left Breaker Frame.



Fig. 17 PT Wires Secured to the Sensor Harness.

For Kits Supplied with a Breaker Mounted CPT and / or Auxiliary Switch Only.

STEP 5: INSTALLING THE BREAKER MOUNTED CPT



Fig. 18 Overview: Breaker Mounted CPT Installed in the Breaker.

- A. Remove and save the (2) .190 - 32 x .250" screws securing the fuse clips and male spade connector installed on the CPT. Discard the fuse clips and spade connector, then reinstall the screws in the CPT Terminals.



Fig. 19 Fuse Clips and Spade Connector Removed from the CPT

- B. Align the CPT Module with the holes in the CPT Mounting Bracket as shown. Note that when viewed from the angled end of the Mounting Bracket, the "X" Terminals should be towards the left edge of the Mounting Bracket. Secure the CPT Module to the CPT Mounting Bracket using the (4) .190-32 x .500" screws, (8) flat washers, (4) lock washers, and (4) nuts supplied.



Fig. 20 CPT Module Installed on the Mounting Bracket.

- C. Using Drilling Plan "A", drill two (2) .281" diameter holes in the bottom front Breaker Channel. Note that it may be necessary to temporarily remove the existing wire ties and mounting pad in order to drill the Breaker Channel.

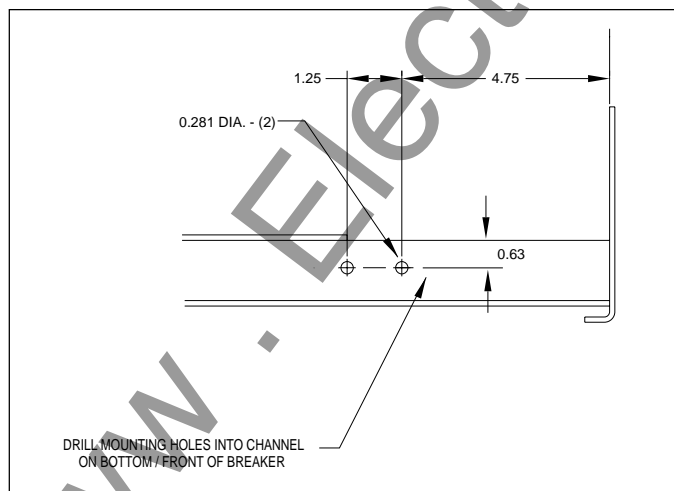

Fig. 21 Drilling Plan "A".

- NOTE:** The Load Side HV Wires are longer than necessary and are cut during the following step. Before cutting the wires, be sure that sufficient length is left so that the HV Wire Fuses are accessible and that the connections can be made to the correct "H" terminals on the CPT.

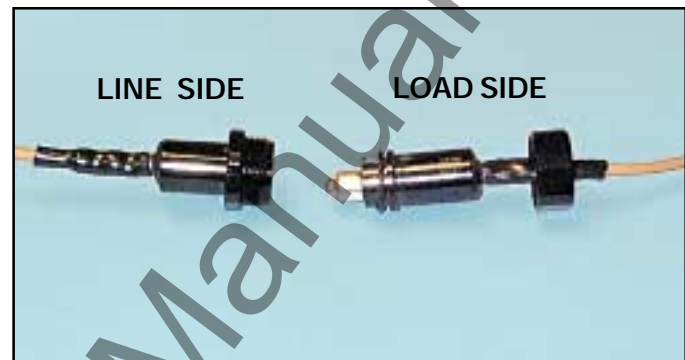

Fig. 22 Load and Line Sides of the HV Wires.

- D. Set the CPT Assembly in front of the bottom front Breaker Channel, near the holes drilled in Step C. Position the HV Fuses along the right side of the Breaker, roughly half way between the front and back of the Breaker.
- E. Mark and cut the Load Side of each HV Wire to an appropriate length for connection to the "H" terminals of the CPT. Strip an appropriate length of insulation from the Load Side HV Wires and attach a .138" ring terminal to each. Attach the HV Wires to the CPT terminals to achieve the required voltage (see Table 3).

- NOTE:** The terminals to which the Load Side HV wires are connected determine the voltage of the CPT. Verify that the line voltage of the circuit matches the CPT voltage BEFORE putting the Breaker into service.

Table 3 CPT High Voltage Taps for Standard and Special Order CPTs

Standard CPT (Style #9A10037G01 & G02)	
<i>Voltage Required</i>	<i>CPT Terminals Used</i>
480 Volt Circuit	H1 & H4
240 Volt Circuit	H2 & H4
208 Volt Circuit	H3 & H4
Special Order 575 Volt CPT (Style #9A10037G03 & G04)	
575 Volt Circuit	H1 & H4
460 Volt Circuit	H2 & H4
230 Volt Circuit	H3 & H4

F. Connect the CPT Wires to the appropriate "X" terminals of the CPT Module as shown. See Table 4 for Tap information. Temporarily route the CPT Wires towards the left side of the Breaker. These will be routed and connected along with the Sensor Harness later in the Retrofit Process.

Table 4 CPT Low Voltage Taps for Standard and Special Order CPTs (After Removing Fuse Clips)

Standard CPT (Style #9A10037G01 & G02)	
<i>120 Voltage Required</i>	<i>CPT Terminals Used</i>
Secondary Circuit	X1 & X2
Special Order 575 Volt CPT (Style #9A10037G03 & G04)	
Secondary Circuit	X1 & X2

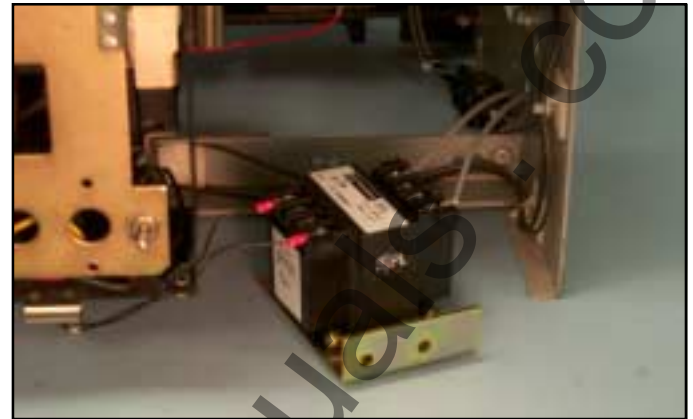

Fig. 23 HV and CPT Wires Connected to the CPT Module.

G. After the HV and CPT Wires have been connected to the proper terminals of the CPT, install the "A" and "B" Finger-Safe Covers over the CPT Terminals as shown. Secure the Finger-Safe Covers to the CPT using the (4) .098 - 28 x .375" screws supplied with the CPT Kit. Torque the screws to 8 - 10 in./lbs.

NOTE: The "C" and "D" Finger-Safe Covers supplied with the CPT Kit are not used in this application and should be discarded.



Fig. 24 Finger-Safe Covers Installed on the CPT Module.

H. For Kits Supplied with an Auxiliary Switch Only: Cut 2.88" off the Microswitch Arm. Align the Microswitch, as shown, with the existing holes in the Auxiliary Switch Mounting Bracket. Secure the Microswitch to the Mounting Bracket using the (2) .138-32 x 1.00" screws, (4) flat washers, (2) lock washers, and (2) nuts supplied.

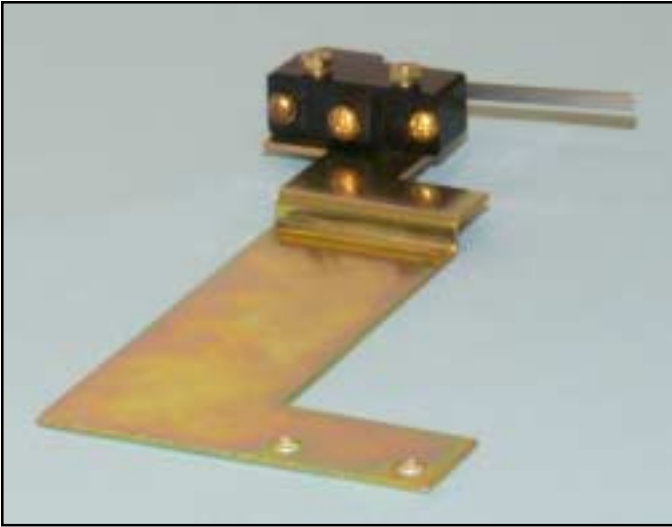

Fig. 25 Microswitch Mounted to the Auxiliary Switch Mounting Bracket.

- I. Align the CPT Assembly, as shown, with the holes drilled in the bottom front Breaker Channel in Step 5-C. Secure the CPT Assembly to the bottom front Breaker Channel using the (2) .250-20 × .750" bolts, (4) flat washers, (2) lock washers, and (2) nuts supplied.

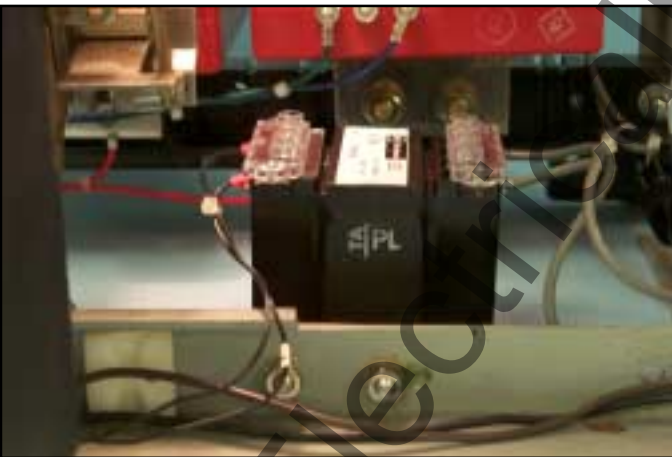

Fig. 26 CPT Assembly Installed in the Breaker.

For Kits Supplied with an Auxiliary Switch Only: The hardware and holes used to secure CPT Assembly to the Breaker are also used to secure the Auxiliary Switch Assembly. The Auxiliary Switch Mounting Bracket should be placed behind the CPT Mounting Bracket, as shown.



Fig. 27 Auxiliary Switch and CPT Assemblies Installed in the Breaker.

As the Auxiliary Switch Assembly is being installed in the Breaker, insure that the Auxiliary Switch Arm engages the Closing Link as shown.



Fig. 28 Correct Engagement of the Auxiliary Switch Arm.

NOTE: The power convention of Circuit Breakers is normally Top to Bottom, meaning the Top Load Terminals (Breaker Stabs) are on the Line Side of the Breaker and the Bottom Load Terminals are on the Load Side.

The HV Wires from the CPT MUST BE ATTACHED to the Line Side of the Breaker. If it is determined that the power flow for the Breaker application is opposite the normal convention, the HV Wires must be attached to the Bottom Load Terminals. In the case of the Line Side being the Bottom Load Terminals, the bolts that secure the Load Terminals to the Jumpers can be used for HV Wire attachment.

NOTE: The Line Side HV Wires are longer than necessary and are cut during the following steps. Before cutting the wires, be sure that sufficient length is left so that the HV Wire Fuses are accessible and that the connections can be made to the correct Load Terminals.

- J. Route the HV Line Side Wires up towards the appropriate Top Load Terminals. Cut each HV Wire to an appropriate length, then strip .250" from each wire.

NOTE: There are two distinct types of Finger Clusters that were used on FP 50 / 65 H-2. Finger Clusters that are secured to the Load Terminals from the sides; and Finger Clusters that are secured to the Load Terminals from the top. The following procedures detail HV Wire connection for both applications.

- K. *For Finger Clusters Secured to the Load Terminals from the Sides:* Crimp a .312" ring terminal to each HV Wire. Completely remove the mounting hardware from one side of the appropriate Finger Clusters. Loosen the hardware on the opposite sides of each Finger Cluster. Slide the HV Wire ring terminals between the Finger Clusters and the Load Terminals as shown.



Fig. 29 Correct Orientation of the HV Wire Ring Terminals.

Using the original bolts and the (2) new .250" washers supplied, secure the HV Wires to the Finger Clusters and Load Terminals.



Fig. 30 HV Wires Connected to Side Secured Finger Clusters.

- L. *For Finger Clusters Secured to the Load Terminals from the Top:* Crimp a .500" ring terminal to each HV Wire. Completely remove one of the two bolts securing the appropriate Finger Clusters to the Load Terminals. Align the HV ring terminals with the Finger Cluster Mounting Holes. Using the original mounting hardware, secure the HV Wires to the appropriate Finger Clusters.



Fig. 31 HV Wires Connected to Top Secured Finger Clusters.

M. Use the nylon wire ties and self adhesive pads supplied to keep the HV Fuses and Wires away from any moving parts.

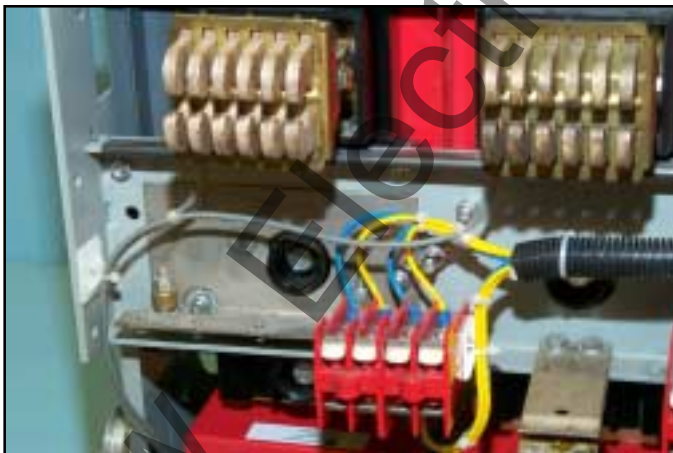
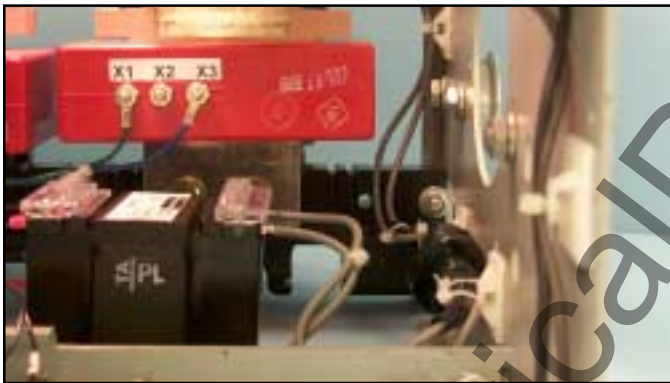

Fig. 32 HV Fuses and Wires Secured Away from Moving Breaker.

N. Install the appropriate CPT Voltage Label in a clearly visible location on the Breaker Face Plate.



Fig. 33 CPT Voltage Labels supplied with the CPT Kit.

STEP 6: INSTALLING THE TRIP FINGER



Fig. 34 Overview: Trip Finger Installed in the Breaker - Long Trip Shaft.

NOTE: FP 50 / 65 H-2 Breakers were equipped with two different Trip Shafts: a long Trip Shaft (as shown in Figure 34) or a short Trip Shaft (as shown in Figure 35). If the Breaker being Retrofitted has a long Trip Shaft, use the new Trip Finger with the Style Number 9A10093G05. If the Breaker being Retrofitted has a short Trip Shaft, use the new Trip Finger with the Style Number 9A10093G06.



Fig. 36 Trip Finger to be used with a Long Trip Shaft (Style Number 9A10093G05).



Fig. 37 Trip Finger to be used with a Short Trip Shaft (Style Number 9A10093G06).



Fig. 35 Short Trip Shaft.

- A. For Breakers with a Short Trip Shaft Only: Remove and scrap the existing Trip Finger and mounting hardware.



Fig. 38 Original Trip Finger Removed from an Electrically Operated Breaker with Short Trip Shaft.

- B. *For Breakers Equipped with a Long Trip Shaft Only:* Align the inner hole in the Trip Finger with the existing hole near the end of the Trip Shaft. Secure the Trip Finger to the Trip Shaft using the (2) .190-32 × 1.25" screws, (4) flat washers, (2) lock washers, and (2) nuts supplied. Note that the screw that "pinches" the Trip Finger together should not be over tightened.

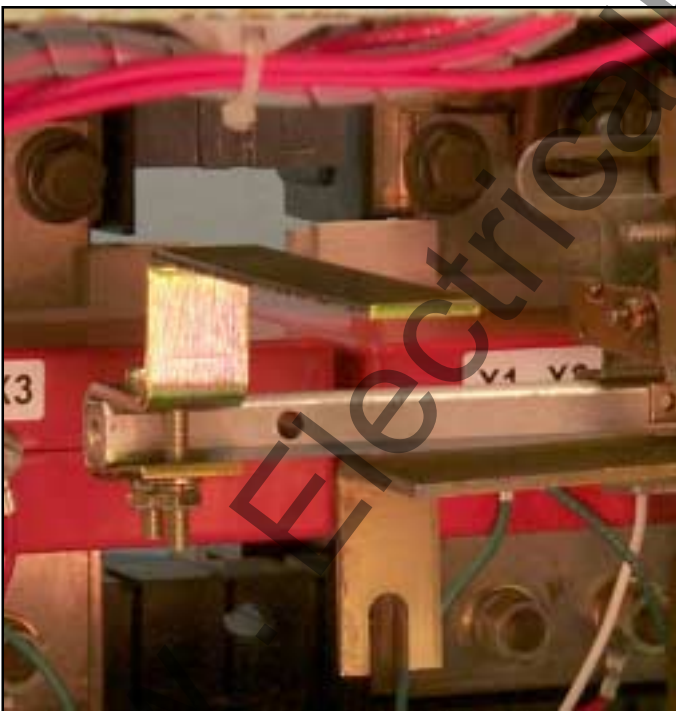

Fig. 39 Trip Finger Installed on a Long Trip Shaft.

For Breakers Equipped with a Short Trip Shaft Only: Align the hole in the Trip Finger with the existing hole near the end of the Trip Shaft. Secure the Trip Finger to the Trip Shaft using the (1) .190-32 × 1.25" screw, (2) flat washers, (1) lock washer, and (1) nut supplied.



Fig. 40 Trip Finger Installed on a Short Trip Shaft.

STEP 7: INSTALLING THE DTA

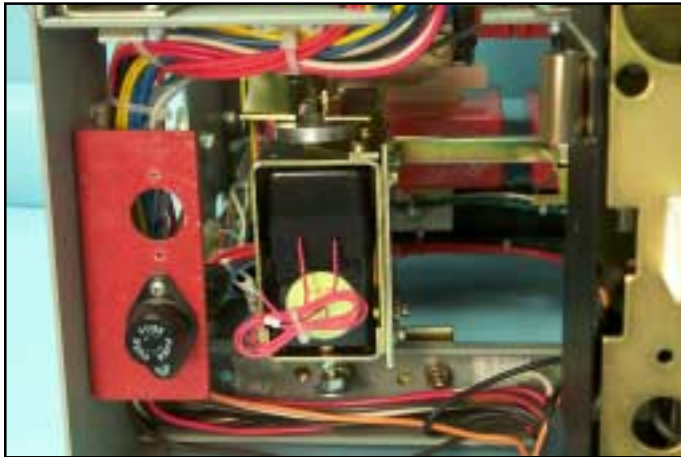

Fig. 41 Overview: DTA Installed in the Breaker.

- A. If existing holes do not already exist, using Drilling Plan "B", drill two (2) .281" diameter holes in the bottom front Breaker Channel. Note that it may be necessary to temporarily remove the existing wire ties and mounting pad in order to drill the Breaker Channel.

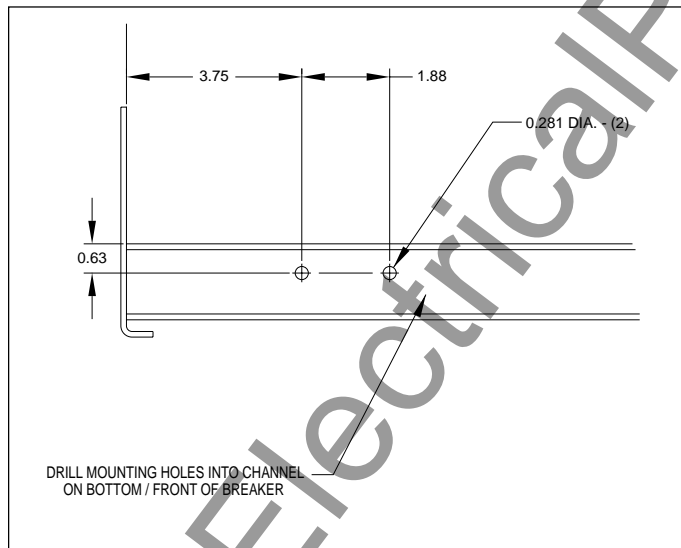

Fig. 42 Drilling Plan "B".

- B. Remove the nut and one (1) wide flat washer from the end of the DTA Reset Shaft.



Fig. 43 Hardware to Remove from the DTA Trip Shaft.

- C. Align the DTA, as shown, with the existing holes or the holes drilled in Step 7-A. Secure the DTA to the bottom front Breaker Channel using the (2) .250-20 x .625" bolts, (4) flat washers, (2) lock washers, and (2) nuts supplied.

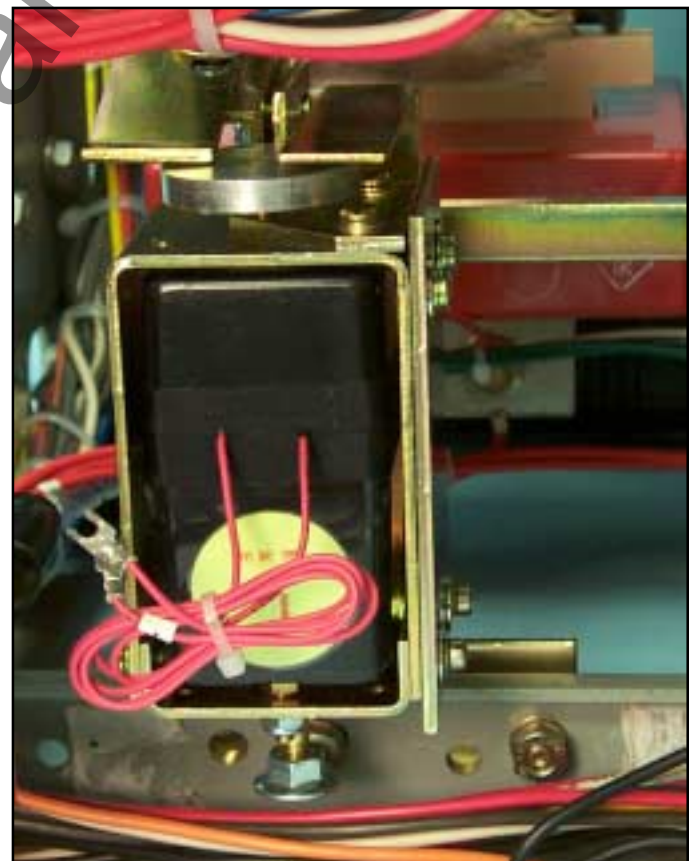

Fig. 44 DTA Mounted to the Bottom Front Breaker Channel.

NOTE: For the following procedures, it is recommended that the Retrofitter have both the Breaker's Slow Close Handle and an appropriate block of wood available.

- D. Using the Slow Close Handle, slightly move the Closing Link forward towards the "Closed" position. Place a block of wood between one of the Closing Links and the inner Breaker Frame. Slowly move the Slow Close Handle towards the back of the Breaker until the wood block is engaged.



Fig. 45 Slow Close Handle Engaged in the Closing Link.

- E. Align the slot in the "L" Bracket with the DTA Reset Shaft. Using the (1) .375-16 x 1.00" shoulder bolt, (3) flat washers, and (1) nut supplied, loosely mount the Reset "L" Bracket, as shown, to the Closing Link. Note that extra flat washer is to be installed between the "L" Bracket and the Closing Link.

Tighten the nut, then back it off three (3) to four (4) turns. Apply Loc-Tite® 243 to the threads of the bolt, fully tighten the nut, then back the nut off one-half to one turn to allow the "L" Bracket to pivot.

- F. Using the wide flat washer and nut removed in Step 7-B, secure the "L" Bracket to the DTA Reset Shaft.



Fig. 46 Reset "L" Bracket Installed on the DTA Shaft.

- G. Again using the Slow Close Handle, release the pressure on the Closing Link and remove the wood block. Return the Breaker to the fully "Open" position.

- H. Back-off the nuts on the DTA Reset Shaft. Apply Loc-Tite® 243 to the threads of the Reset Shaft. Adjust the nut below the "L" Bracket on the Reset Shaft until a cage height of .875" is achieved. Fully tighten the nut securing the Reset "L" Bracket to the Reset Shaft.

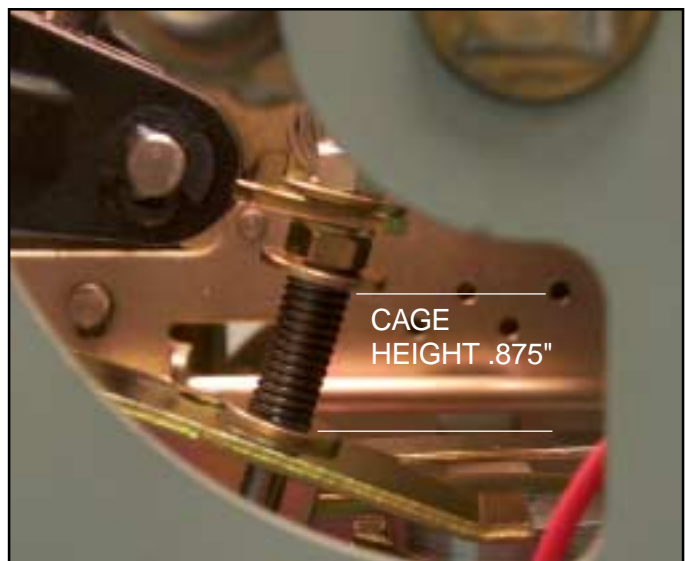

Fig. 47 Proper Cage Height Adjustment.

I. "Close" the Breaker.

NOTE: Throughout the Trip System Setup procedure, be sure to keep hands and fingers away from any moving parts within the Breaker. Failure to do so could result in serious injury.

J. Back-off the DTA Trip Disk. Apply Loc-Tite® 243 to the threads of the DTA Shaft. Turn the DTA Trip Disk until a gap of .070 to .100 is achieved between the top of the Disk and the bottom of the Trip Finger.

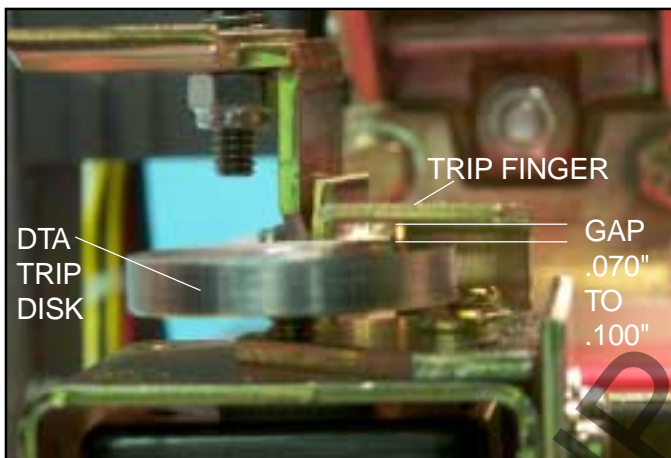

Fig. 48 Proper Air Gap Adjustment.

K. Return the Breaker to the "Open" position.

L. Using the self-adhesive mounting pads and wire ties supplied, secure the original wiring to the Breaker Channel.

M. Route the DTA Wires, the Sensor Harness, and if applicable the CPT wires as shown towards the top of the Breaker. Use the wire ties supplied to secure and bundle the wires to keep them clear of any moving parts within the Breaker.



Fig. 49 Routing and Securing of the Original and New Wiring.

STEP 8: INSTALLING THE AUX. CT MODULE ASSEMBLY AND THE TRIP UNIT



Fig. 50 Overview: Aux. CT Assembly and Trip Unit Installed on the Breaker.

NOTE: For Steps 8-A through 8-E, the original components removed and saved during Step 2 will be reinstalled. Refer to the Federal Pioneer 50 / 65 H-2 Instruction Manual, originally supplied with the Breaker, to perform the reinstallations.

- A. Reinstall the Phase 1 & 2 and Phase 2 & 3 Interphase Barriers.
- B. Using the original hardware, reinstall the Flash Barrier.
- C. Reinstall the Side Barriers.
- D. Reinstall the Arc Chutes, the Arc Chute Holders, and the Mounting Knobs.
- E. Reinstall the Hood Assembly.

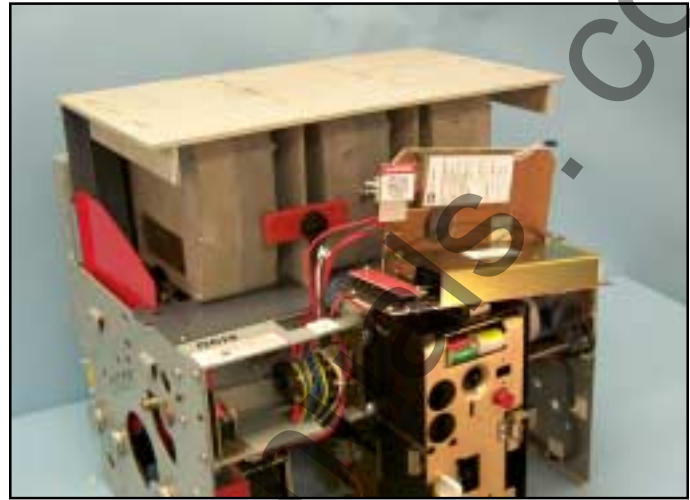

Fig. 51 Original Components Reinstalled on the Breaker.

- F. Remove and scrap the existing hardware from the top, front right corner of the Breaker and near the top, left rear corner of the Face Plate Box.

NOTE: If no holes exist at these locations, use Drilling Plan "C" to drill two (2) .281" holes in the top Breaker Frame.

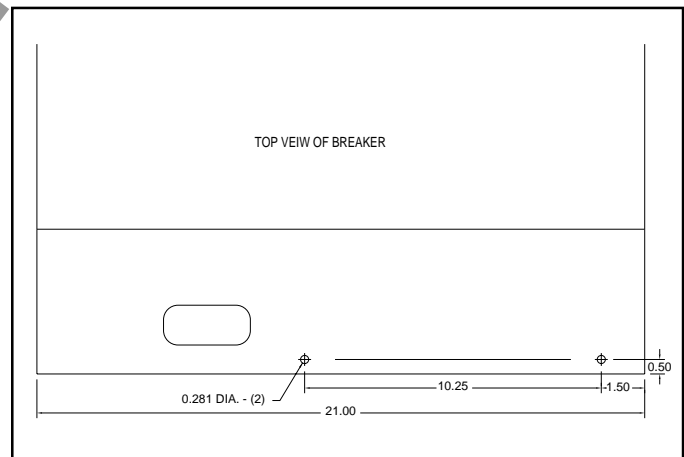

Fig. 52 Drilling Plan "C".

- G. Align the right and left Aux. CT Module Mounting Brackets, as shown, with the holes from which the hardware was just removed. Secure the Aux. CT Module Mounting Brackets to the Breaker using the (2) .250-20 × .625" bolts, (2) lock washers, and (2) flat washers supplied. If the existing holes are not threaded, or if the holes were drilled during this process, use the additional (2) .250-20 nuts and (2) flat washers supplied to secure the Aux. CT Module Mounting Brackets.



Fig. 53 Aux. CT Module Mounting Brackets Installed on the Breaker.

- H. Align the Aux. CT Module Assembly with the holes in the Aux. CT Module Mounting Brackets. Secure the Aux. CT Module Assembly to the Brackets using the (4) .190-32 × .500" flat head screws.
- I. Route the Sensor Harness and the DTA Wires towards the Aux. CT Module Terminal Block.

For Kits Supplied with a Breaker Mounted CPT Only: Route the CPT wires across the top of the Aux. CT Module, against the bottom of the Glass Poly Barrier. If necessary, use the self-adhesive mounting pad and wire tie supplied to hold the CPT Wires in place.



Fig. 54 Aux. CT Module Assembly Installed on the Breaker and Preliminary Routing of the Sensor Harness, DTA Wires, and CPT Wires.

- J. Remove and save the Aux. CT Module Terminal Block Cover and mounting hardware.
- K. Connect the "+" DTA Wire to the "OP" terminal of the 7-Point Terminal Block and the unmarked wire to the "ON" terminal.



Fig. 55 DTA Wires Connected to the Aux. CT Module Terminal Block.

- L. Connect the Sensor Harness to the proper terminals of the 7-Point Terminal Block. Refer to Section 12 of the Retrofit Application Data, supplied with the Retrofit Kit, for detailed wiring specifications.

Note that the Sensor Harness Ground Wire (with ring terminal) will be connected later in the Retrofit Process.

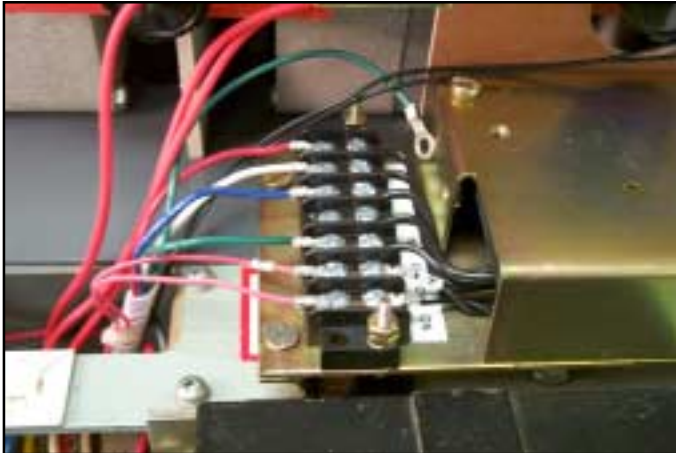

Fig. 56 Sensor Harness Connected to the Aux. CT Module Terminal Block.

- M. Reinstall the 7-Point Terminal Cover.
- N. Mount the Trip Unit to the top of the Aux. CT Module as shown using the (2) .190-32 x 4.00" screws, (2) lock washers, (2) flat washers, and (2) spacers supplied. Note that the brass spacers are positioned between the top of the Aux. CT Module and the bottom rear of the Trip Unit. Do not fully tighten the screws at this time.
- O. Mount the left and right Trip Unit Support Clips to the sides of the Aux. CT Module and into the bottom front slots in the Trip Unit as shown. Secure using the (4) .190-32 x .500" screws, (4) lock washers, and (4) flat washers supplied. Use one of the left Support Clip Mounting Screws to secure the Sensor Harness Ground Wire to the Aux. CT Module.

Secure the Trip Unit by tightening the 4.00" screws installed in Step 8-N.

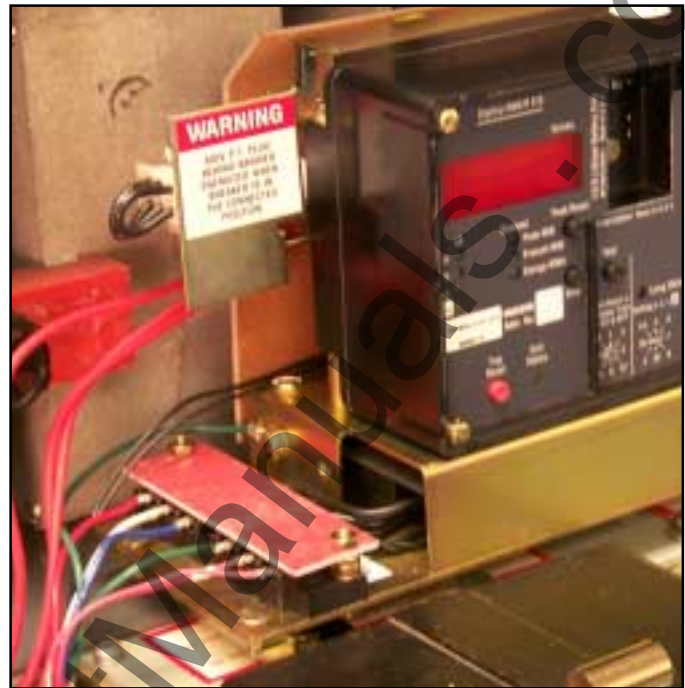

Fig. 57 Support Clips and Sensor Harness Ground Wire Connected to the Aux. CT Module.

- P. Remove the Trip Unit Cover and install the Rating Plug supplied with the Retrofit Kit. Reinstall the Cover.
- Q. Install the Aux. CT Harness between the Trip Unit and the Aux. CT Module.



Fig. 58 Rating Plug and Aux. CT Harness Installed.

- R. Use the self-adhesive mounting pads and wire ties supplied to secure the Sensor Harness, DTA Wires and if applicable, the PT Wires and CPT Wires away from any moving parts within the Breaker.
- S. Install the Digitrip Retrofit Label on the top of the Trip Unit.

STEP 9: INSTALLING THE EXTERNAL HARNESS AND FINAL WIRING



Fig. 59 Overview: External Harness Installed on the Breaker.

- A. Connect the External Harness to the Trip Unit.

NOTE: For 510 Basic Kits, the External Harness is the shorting plug pictured below. It is to be plugged into the right side of the Trip Unit.



Fig. 60 510 Basic Kit External Harness Shorting Plug.

- B. *For Kits Supplied with a PT Module Only:* Plug the connector from the PT Module into its receptacle on the External Harness.

- C. *For Kits Supplied with an Auxiliary Switch Only:* Route the two (2) wires (with ring terminals) from the External Harness, down through the Breaker to the Auxiliary Switch. Connect one (1) wire to the normally "Open" terminal and the other wire to the "Common" terminal of the Auxiliary Switch.



Fig. 61 External Harness Wires Connected to the Auxiliary Switch.

- D. *For Kits Supplied with a Breaker Mounted CPT Only:* Remove the External Harness plug installed in the bottom rear socket of the Trip Unit. Insert the black plug of the CPT Harness into the same receptacle in the Trip Unit. Reinsert the External Harness Plug just removed into the female receptacle on the CPT Harness.



Fig. 62 External Harness Connections at the Trip Unit.

- E. Secure the External Harness to the right Breaker Frame using the self-adhesive mounting pad and wire tie supplied.



Fig. 63 External Harness Secured to the Side of the Breaker.

- F. Use the self-adhesive mounting pads and wire ties supplied to dress all wires and harnesses to keep them away from any moving parts within the Breaker.
- G. If the Breaker Face Plate, Floating Trim, and Charging Handle were removed during the Retrofit, reinstall them using the original mounting hardware.

STEP 10: TESTING THE BREAKER

- A. Measure the force necessary to trip the Breaker at where the Trip Finger impacts the DTA Adjusting Disk. The force necessary to trip the Breaker **MUST NOT EXCEED** 3 lbs.
- B. The Retrofit must be tested using primary injection. Refer to Section 8 of the Instructions for the *Application of Digitrip RMS Retrofit Kits on Power Circuit Breakers* (Publication AD 33-855-3, May 2001), supplied with the Retrofit Kit, for detailed testing procedures and specifications. For test information specific to the Trip Unit, refer to the IL publication supplied with the Retrofit Kit (see the Pick List for the IL number).
- C. While Section 8 of the *Instructions for the Application of Digitrip RMS Retrofit Kits on Power Circuit Breakers* provides the information necessary for testing the Breaker, please keep the following notes in mind when reviewing other sections of the publication.

**CAUTION**

WHEN ALL TESTING IS COMPLETE, THE TRIP UNIT MUST BE RESET. FAILURE TO DO SO MAY CAUSE THE BATTERY IN THE RATING PLUG TO RUN DOWN.

NOTES:

1. ***For All Kits Other Than 510 Basic:*** If testing the Breaker with Short Delay or Ground Fault functions, be sure to either plug in the Cell Harness Assembly or use the Zone Interlock Shorting Plug. Failure to do so may result in shorter than expected trip times.
2. ***For 810 and 910 Kits Only:*** Without any power applied to the system (neither the 120 volt power supply nor the Aux. Power Module connected), plug the External Harness into the Cell Harness and check the impedance between COM 1 and COM 2. The impedance should be between one (1) and three (3) ohms. If the impedance is not within this range, trace the wiring and examine each connection to assure its integrity.

Confirm that the PowerNet communication wiring is correct by following the procedures detailed in Section 7.4 of the Instructions for the Application of Digitrip RMS Retrofit Kits on Power Circuit Breakers. Note that for 810 and 910 Kits, the impedance between COM 1 and COM 2 should be between one (1) and three (3) ohms.

When testing is complete, disconnect the External Harness from the Cell Harness. Final External Harness connection will be performed later in the Retrofit Process.

STEP 11: MOUNTING THE CELL HARNESS

- A. The Cell Harness is to be mounted in the Breaker Cell. The connector end is to be mounted on the left side of the Cell, in a location suitable for connection with the External Harness. The Terminal Blocks can be mounted anywhere space is available in the Cell as long as connection to the External Harness can be made.
- B. Route the Cell Harness wiring to keep it away from any moving parts within the Cell Housing.

STEP 12: INSTALLING THE RETROFITTED BREAKER IN THE CELL**WARNING**

DO NOT LEAVE THE BREAKER IN AN INTERMEDIATE POSITION IN THE SWITCHGEAR CELL. ALWAYS LEAVE IT IN THE CONNECTED, DISCONNECTED, OR (OPTIONAL) TEST POSITION. FAILURE TO DO SO COULD LEAD TO IMPROPER POSITIONING OF THE BREAKER AND FLASHOVER, CAUSING DEATH, SERIOUS PERSONAL INJURY, AND / OR PROPERTY DAMAGE.

NOTE: It is the responsibility of the Retrofitter to insure proper Breaker / Cell fit. When racking the Breaker into the Connected position, the Retrofitter **MUST FOLLOW BOTH** the manufacturer's instructions and the customer's safety standards and procedures for racking a Breaker into the Connected position.

- A. With the Breaker in the Open position and the springs discharged, slowly rack the Breaker into the Connected position, making sure there is no interference or binding. The Breaker should rack smoothly and without mechanical interference between any Breaker and Cell parts. The Retrofitter will feel some resistance when the primary fingers connect onto the stabs of the Cell. This is normal.

However, if any unusual resistance is detected that could be abnormal interference between the Breaker and Cell parts, stop immediately and move the Breaker out of the Connected position. Examine what is causing the interference and correct the situation.

Digitrip Retrofit Kit Installation Components for Federal Pioneer 50 / 65 H-2 Breaker RMS/R Retrofits

Step	Description		Qty.	Comment
Step 3	Sensor	See Pick List	3	
	Sensor Mounting Parts	9A10093G04	1	
	Spacer		6	
	Sensor Harness Parts	9A10093G07	1	
	Sensor Harness	See Pick List	1	
	Mounting Pad - 1 ", Self Adhesive		6	
	Wire Tie Nylon		16	
Step 4	Aux. CT Module	6503C59G__	1	
	Trip Unit Mounting Parts	9A10093G10	1	
	Trip Unit Barrier		1	
	Aux. CT Mounting Bracket R. H.		1	
	Aux. CT Mounting Bracket L. H.		1	
	Support Clip RH		1	
	Support Clip LH		1	
	.250-20 x .625 Lng. Bolt Stl.		2	
	.250 Flat Washer Stl.		4	
	.250 Lock Washer Stl.		2	
	.250-20 Nut Hex Stl.		2	
	.190-32 x 4.00 Lng. Screw Fil.		2	
	.190-32 x .500 Lng. Screw F. H.		4	
	.190-32 x .500 Lng. Screw P. H.		4	
	.190-32 x .375 Lng. Screw P. H.		2	
	.190 Flat Washer Stl.		8	
	.190 Lock Washer Stl.		8	
	Spacer Brass		2	
	Label Digitrip Retrofit		1	
	PT Module	6502C82G01	1	} Comm. Only
	Ring Terminal (.190, .250, .312, .375, .500 -Each Size)		3	
	PT Module Mounting Parts	9A10093G11	1	
	.138-32 x .500 Lng. Screw P. H.		2	
	.138 Flat Washer Stl.		4	
	.138 Lock Washer Stl.		2	
	.138-32 Nut Hex Stl.		2	
Wire Tie Nylon				From Step 3
Step 5	Breaker Mounted CPT Kit	See Pick List	1	} CPT Only
	MTE Transformer		1	
	HV Fused Wires		2	
	CPT Wires		1	
	Mounting Hardware Kit		1	
	.190-32 x .750 Lng. Screw Fil.		4	
	.190-32 x .375 Lng. Screw Fil.		2	
	.190 Flat Washer Stl.		10	
	.190 Lock Washer Stl.		6	
	.190-32 Nut Hex Stl.		4	
Ring Terminal (.138, .190, .250, .312, .375, .500 -Each Size)		2		

Digitrip Retrofit Kit Installation Components for Federal Pioneer 50 / 65 H-2 Breaker RMS/R Retrofits

Step	Description	Qty.	Comment	
Step 5 (cont.)	Wire Tie Nylon	12	}	
	Warning Label (208, 240, 480, & 575 Volt - Each)	1		
	Finger-Safe Cover Kit	1		
	Cover (A, B, C, & D Each)	1		
	.098-28 × .375 Lng. Screw Fil.	4		
	CPT Mounting Parts	1		
	CPT Mounting Bracket	1		
	.250-20 × .750 Lng. Bolt Stl.	2		
	.250 Flat Washer Stl.	6		
	.250 Lock Washer Stl.	2		
	.250-20 Nut Hex Stl.	2		
	.190-32 × .500 Lng. Screw F. H.	4		
	.190 Flat Washer Stl.	8		
	.190 Lock Washer Stl.	4		
	.190-32 Nut Hex Stl.	4		
	Auxiliary Switch Kit	1		
	Microswitch	1		
	Auxiliary Switch Mounting Bracket	1		
	.250-20 × .750 Lng. Bolt Stl.	2		
	.250 Flat Washer Stl.	4		
.250 Lock Washer Stl.	2			
.250-20 Nut Hex Stl.	2			
.138-32 × 1.00 Lng. Screw Fil.	2			
.138 Flat Washer Stl.	4			
.138 Lock Washer Stl.	2			
.138-32 Nut Hex Stl.	2			
Mounting Pad - 1", Self Adhesive				
Wire Tie Nylon				
Step 6	Trip Finger Parts (Long Trip Shaft)	1	}	
	Trip Finger	1		
	.190-32 × 1.25 Lng. Screw Fil.	2		
	.190 Flat Washer Stl.	4		
	.190 Lock Washer Stl.	2		
	.190-32 Nut Hex Stl.	2		
	Trip Finger Parts (Short Trip Shaft)	1		
	Trip Finger	1		
	.190-32 × 1.25 Lng. Screw P.H.	1		
	.190 Flat Washer Stl.	2		
	.190 Lock Washer Stl.	2		
	.190-32 Nut Hex Stl.	1		
Step 7	DTA Assembly	1		}
	DTA Mounting Parts	1		
	.250-20 × .625 Lng. Bolt Stl.	2		
	.250 Flat Washer Stl.	4		
	.250 Lock Washer Stl.	2		

Digitrip Retrofit Kit Installation Components for Federal Pioneer 50 / 65 H-2 Breaker RMS/R Retrofits

Step	Description	Qty.	Comment	
Step 7	.250-20 Nut Hex Stl.	2		
(cont.)	Loc-Tite® 243	1		
	Reset Parts	1		
	9A10093G09	1		
	L Bracket Reset	1		
	.375-16 × 1.00 HEX BOLT	1		
	.375-16 HEX NUT	1		
	.375 FLAT WASHER	3		
	Loc-Tite® 243	1		
	Mounting Pad - 1 “, Self Adhesive		} From Step 3	
	Wire Tie Nylon			
Step 8	Aux. CT Mounting Bracket R. H.	1	} From Step 4	
	Aux. CT Mounting Bracket L. H.	1		
	Support Clip R. H.	1		
	Support Clip L. H.	1		
	.250-20 × .625 Lng. Bolt Stl.	2		
	.250 Flat Washer Stl.	4		
	.250 Lock Washer Stl.	2		
	.190-32 × 4.00 Lng. Screw Fil.	2		
	.190-32 × .500 Lng. Screw F. H.	4		
	.190-32 × .500 Lng. Screw P. H.	4		
	.190-32 × .375 Lng. Screw P. H.	2		
	.190 Flat Washer Stl.	8		
	.190 Lock Washer Stl.	8		
	Spacer Brass	2		
	Label Digitrip Retrofit	1		
	Auxiliary CT Harness	1		
	6502C84G01	1		} From Step 3
	Mounting Pad - 1 “, Self Adhesive			
	Wire Tie Nylon			
Step 9	External Harness	1	Except 510 Basic	
	Mounting Pad - 1 “, Self Adhesive		} From Step 3	
	Wire Tie Nylon			
Step 11	Cell Harness	1	See Pick List	

NOTE: Due to the wide variety of Breakers and the multiple functions of the Retrofit components, some excess hardware may remain when the Retrofit is complete.

Table 5 Torque Values for General Mounting and Screw Size Conversion

<i>Decimal Size (in)</i>	<i>Standard Size</i>	<i>Torque (in-lbs)</i>	<i>Torque (ft-lbs)</i>
.112	4-40	10	0.8
.138	6-32	18	1.5
.164	8-32	36	3.0
.190	10-32	46	3.8
.250	1/4-20	100	8.3
.312	5/16-18	206	17.2
.375	3/8-16	356	29.7
.438	7/16-14	572	47.7
.500	1/2-13	856	71.3

Table 6 Torque Values for Copper BUS Connectors

<i>Decimal Size (in)</i>	<i>Standard Size</i>	<i>Torque (in-lbs)</i>	<i>Torque (ft-lbs)</i>
.250	1/4-20	60	5
.312	5/16-18	144	12
.375	3/8-16	240	20
.500	1/2-13	600	50

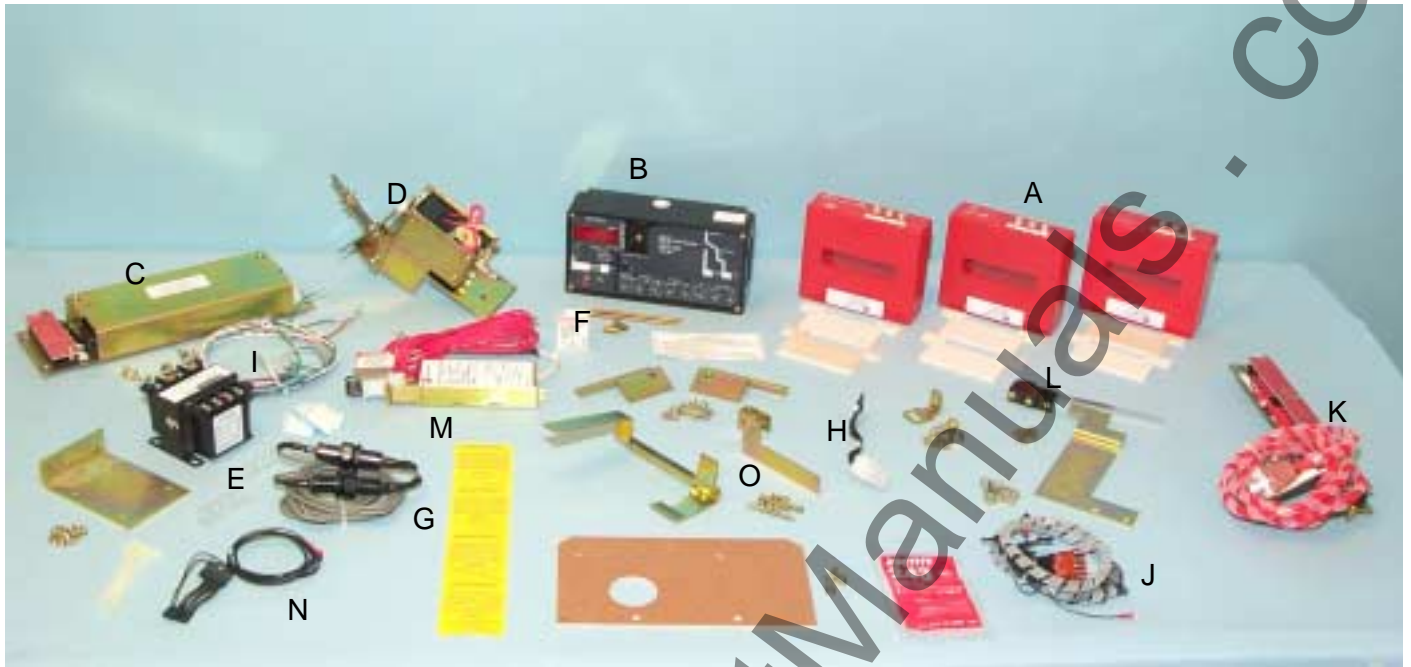

Fig. 64 Retrofit Components

- | | |
|-------------------------------|------------------------|
| A. Sensors | I. Sensor Harness |
| B. Trip Unit | J. External Harness |
| C. Aux. CT Module | K. Cell Terminal Block |
| D. Direct Trip Actuator (DTA) | L. Aux. Switch |
| E. CPT Transformer | M. PT Module |
| F. Rating Plug | N. CPT Harness |
| G. HV Wires | O. Trip Finger(s) |
| H. Aux. CT Harness | |

Notes

www.ElectricalPartManuals.com

Notes

www.ElectricalPartManuals.com

Notes

www.ElectricalPartManuals.com

Notes

www.ElectricalPartManuals.com

We wish to thank you for purchasing the Digitrip Retrofit System. Digitrip Retrofit Kits are designed and manufactured in America with pride. All the components are engineered to fit the existing Circuit Breaker with little or no modifications to the existing Breaker. However due to the wide variety and vintage of Breakers in use today, an occasional problem may arise. Please contact us with any questions, comments or concerns.

Phone: 1-800-937-5487 Fax. (724) 779-5899

The instructions for installation, testing, maintenance, or repair herein are provided for the use of the product in general commercial applications and may not be appropriate for use in nuclear applications. Additional instructions may be available upon specific request to replace, amend, or supplement these instructions to qualify them for use with the product in safety-related applications in a nuclear facility.

The information, recommendations, descriptions, and safety notations in this document are based on Cutler-Hammer's experience and judgement with respect to Retrofitting of Power Breakers. This information should not be considered to be all inclusive or covering all contingencies. If further information is required, Cutler-Hammer should be consulted.

NO WARRANTIES, EXPRESSED OR IMPLIED, INCLUDING WARRANTIES OF FITNESS FOR A PARTICULAR PURPOSE OR MERCHANTABILITY, OR WARRANTIES ARISING FROM COURSE OF DEALING OR USAGE OF TRADE, ARE MADE REGARDING THE INFORMATION, RECOMMENDATIONS AND DESCRIPTIONS CONTAINED HEREIN. In no event will Cutler-Hammer be responsible to the user in contract, in tort (including negligence), strict liability or otherwise, for any special, indirect, incidental, or consequential damage or loss whatsoever, including but not limited to damage to or loss of use of equipment, plant or power system, cost of capital, loss of profits or revenues, cost of replacement power, additional expenses in the use of existing power facilities, or claims against the user by its customers resulting from the use of the information, recommendations, and descriptions contained herein.

Cutler-Hammer

Pittsburgh, Pennsylvania U.S.A.

Publication No. I.L. 33-FHC-2
September 2001
Printed in U.S.A./TBG00045

EATON