



# INSTRUCTIONS FOR MAGNUM DS METAL-ENCLOSED LOW-VOLTAGE SWITCHGEAR ASSEMBLIES WITH MAGNUM DS BREAKERS

Read and understand these instructions before attempting to unpack, assemble, operate or maintain this type equipment.

All possible contingencies which may arise during installation, operation or maintenance, and all details and variations of this equipment do not purport to be covered by these instructions. If further information is desired by purchaser regarding his particular installation, operation or maintenance of particular equipment, contact the local Cutler-Hammer representative.

installation, operation and maintenance of Magnum DS Metal-Enclosed Low-Voltage Switchgear used with Magnum DS Power Air Circuit Breakers.

For application information consult applicable descriptive bulletins, application publications and/or the applicable industry standards.

For installation, operation and maintenance of Low-Voltage Power Circuit Breakers see separate instruction books.

### SAFETY

All safety codes, safety standards and/or regulations must be strictly observed in the installation, operation and maintenance of this equipment.



**METAL-ENCLOSED LOW-VOLTAGE SWITCHGEAR ASSEMBLIES COVERED BY THESE INSTRUCTIONS ARE DESIGNED AND TESTED TO OPERATE WITHIN THEIR NAMEPLATE RATINGS. OPERATION OUTSIDE OF THESE RATINGS MAY CAUSE THE EQUIPMENT TO FAIL RESULTING IN DEATH, SERIOUS INJURY AND/OR PROPERTY DAMAGE. ALL RESPONSIBLE PERSONNEL SHOULD LOCATE THE EQUIPMENT NAMEPLATE AND BE FAMILIAR WITH THE INFORMATION PROVIDED ON THE NAMEPLATE. THE MAGNUM DS NAMEPLATE IS SHOWN IN FIGURE 1.**



**THE DANGER, WARNING AND CAUTION MESSAGES INCLUDED AS PART OF THE PROCEDURAL STEPS IN THIS MANUAL ARE FOR PERSONNEL SAFETY AND PROTECTION OF EQUIPMENT FROM DAMAGE. AN EXAMPLE OF A TYPICAL WARNING LABEL HEADING IS SHOWN ABOVE THIS PARAGRAPH TO FAMILIARIZE PERSONNEL WITH THE TYPE OF PRESENTATION. THIS WILL HELP TO ASSURE THAT PERSONNEL ARE ALERT TO THESE MESSAGES. IN ADDITION, THESE MESSAGES ARE ALL UPPER CASE AND BOLDFACE.**

### PURPOSE

This instruction manual is expressly intended to cover the

SWITCHGEAR INFORMATION					
DRAWING NO.	SHOP ORDER	G.O. NUMBER	ITEM NUMBER	MFD. AT	DATE
VOLTAGE	PH	WIRE	SHORT CIRCUIT CURRENT	SHORT TIME CURRENT	HZ
MAIN BUS	SECTION BUS	2.2 kV INSULATION LEVEL			
MAIN NEUTRAL	SECTION NEUTRAL	CUTLER-HAMMER INC. MADE IN THE USA 272P024H01			

Figure 1 Blank Magnum DS Rating Nameplate

**TABLE OF CONTENTS****SECTION 1****INTRODUCTION**

1.1	General Information	4
1.2	Safety Features	4
1.3	Safety Practices	4
1.4	Qualified Personnel	5
1.5	Precautions	5
1.6	Other Publications and Documentation	6

**SECTION 2****RECEIVING, HANDLING AND STORAGE**

2.1	General Information	7
2.2	Receiving	7
2.3	Precautions	7
2.3.1	Overhead Lifting	7
2.3.2	Rolling	8
2.3.3	Shipping Skid and Lifting Plate Removal	8
2.4	Storage	8

**SECTION 3****EQUIPMENT DESCRIPTION**

3.1	General Description	11
3.2	Front Compartment	11
3.2.1	Breaker Cell	12
3.2.1.1	Breaker Cassette	12
3.2.1.1.1	Extension Rails	12
3.2.1.1.2	Breaker Interference Interlocks	12
3.2.1.2	Key Interlocks	13
3.2.1.3	Metering Current Transformers	13
3.2.1.4	Cell Switch	15
3.2.1.5	Space Heaters	15
3.2.1.6	Shutters	15
3.2.2	Secondary Terminal Compartment	15
3.2.3	Control Wiring	16
3.2.4	Auxiliary Compartment	17
3.2.5	Auxiliary/Transition Section	17
3.3	Bus Compartment	17
3.4	Cable Compartment	17
3.5	Ground Bus	17
3.6	Outdoor Enclosure Type 3R	18
3.7	Type Magnum DS Circuit Breakers	18

**SECTION 4****INSTALLATION**

4.1	General Information	19
4.2	Location and Foundation	19
4.2.1	Location	19
4.2.2	Foundation	20
4.2.3	Indoor Equipment	20
4.2.4	Outdoor Equipment	21
4.2.5	Conduits	21
4.3	Shipping Group Assembly	21

## TABLE OF CONTENTS

4.3.1	Assembly Procedures	21
4.4	Bus, Cable and Control Connections	21
4.4.1	Bus Connections	21
4.4.2	Bus Joint Preparation	21
4.4.3	Bolt Tightness	23
4.4.4	Ground Bus	23
4.4.5	Power Cable Lashing	23
4.4.6	Control Connections	24
4.5	Traveling Circuit Breaker Lifter	25
4.6	Moving Parts	25
<b>SECTION 5</b>	<b>INSPECTION AND TESTING PRIOR TO OPERATION</b>	
5.1	General Information	28
5.2	Test Equipment	28
5.3	Connections	28
5.4	Auxiliary Equipment	28
5.5	Ground Fault Systems	28
5.6	Circuit Breakers and Trip Units	29
5.7	Final Steps	29
<b>SECTION 6</b>	<b>PERIODIC INSPECTION AND TESTING</b>	
6.1	General Information	30
6.2	Access to Switchgear Assembly Parts	30
6.2.1	Main Bus and Cable Compartment	30
6.2.2	Drawout Main Disconnecting Contacts and Current Transformers	30
6.2.3	Control Equipment	30
6.3	Inspection and Maintenance Schedule	30
6.3.1	Individual Devices	31
6.3.2	Overall Assembly Installation	31
6.3.3	Buses and Connections	31
6.3.4	Drawout, Main Disconnecting Contacts and Supports	31
6.3.5	Instruments, Relays and Other Panel Devices	31
6.3.6	Secondary Wiring, Blocks and Connections	31
6.3.7	Mechanical Parts	32
6.3.8	Ventilation	32
6.3.9	Records	32
6.3.10	Abnormal Conditions	32
6.3.11	Lubrication	32
6.3.12	Renewal Parts	32

## SECTION 1: INTRODUCTION

### 1.1 GENERAL INFORMATION

Magnum DS Switchgear assemblies with Magnum DS Low-Voltage ac Power Circuit Breakers control and protect power circuits through 600 Volts ac and interrupting capacities through 100 kA at 480 Volts. The switchgear assembly is composed of vertical sections that are arranged to suit the customer's requirements. Magnum DS switchgear utilizes a four high structure design consisting of various combinations of Magnum DS Low-Voltage ac Power Circuit Breakers and auxiliary compartments (Figure 1.1). Rear accessible bus and cable compartments provide space for connections, maintenance and inspection.

This instruction manual contains important procedures and information pertinent to the receiving, handling, storage, installation, operation and maintenance of Magnum DS Low-Voltage Switchgear. Information provided in this instruction manual and by other supplied documentation and/or drawings should be read and understood by all personnel responsible for supervision, operation or maintenance. Familiarization should always include the characteristics of each piece of equipment contained in or mounted on the switchgear assembly.

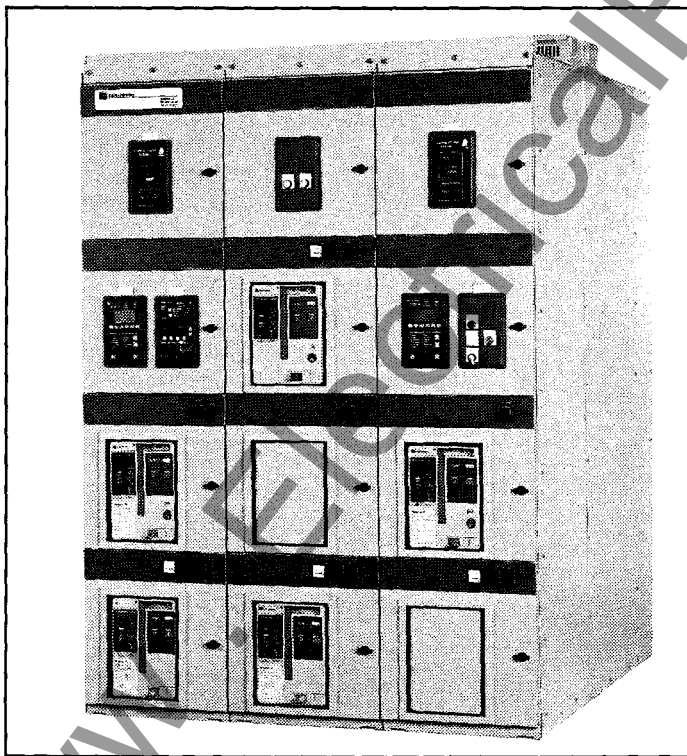

Figure 1-1 Type Magnum DS Low-Voltage Indoor Switchgear (Front View)

Proper installation, operation and maintenance are essential to assure continued satisfactory service from the equipment. It should not be installed in places where it will be required to operate at voltage, currents or fault capacities greater than those for which it was designed, or where the environmental conditions are dirty, corrosive, humid or otherwise harsh or unsuitable. (Ref. ANSI C37.20.1 for abnormal operation conditions).

### 1.2 SAFETY FEATURES

Each Magnum DS Assembly is manufactured with built-in interlocks and safety-related features. They are provided to reduce hazards to operating personnel and provide proper operating sequences.



**METAL-ENCLOSED LOW-VOLTAGE SWITCHGEAR ASSEMBLIES ARE PROVIDED WITH MANY SAFETY FEATURES. NEVERTHELESS, THEY CONTAIN POWER CIRCUITS WITH HIGH FAULT CAPACITY. THE VOLTAGES AND POWER LEVELS AVAILABLE IN THIS EQUIPMENT MAKE CONTACT WITH BARE CONDUCTORS OR TERMINALS EXTREMELY DANGEROUS, AND IS LIKELY TO BE FATAL. ALL POWER SHOULD BE TURNED OFF OR ADEQUATE PROTECTIVE EQUIPMENT USED WHEN WORKING INSIDE SUCH EQUIPMENT. IN ADDITION TO THE HAZARDS INHERENT TO THE SWITCHGEAR ASSEMBLY ITSELF, OPERATION BY UNQUALIFIED PERSONS MAY CAUSE DAMAGE TO CONNECTED EQUIPMENT AND INJURY TO OPERATORS OF CONNECTED EQUIPMENT.**

**UNDER NO CIRCUMSTANCE SHOULD THE INTERLOCKS OR OTHER SAFETY FEATURES BE MADE INOPERATIVE, AS THIS MAY RESULT IN DEATH, BODILY INJURY OR PROPERTY DAMAGE.**

**TO PROTECT PERSONNEL DURING THE INSTALLATION, OPERATION AND MAINTENANCE OF THIS EQUIPMENT, THE FOLLOWING PRACTICES MUST BE FOLLOWED:**

### 1.3 SAFETY PRACTICES

Type Magnum DS Low-Voltage Switchgear is complex high current electrical equipment. It is designed to operate within the voltage and current limitations shown on the nameplate (Figure 1). Do not apply this equipment to systems with voltages and/or currents in excess of these limits.

1. Only qualified electrical personnel familiar with the construction and operation of this equipment and the associated hazards should be permitted to work on such equipment. Additionally, only qualified personnel should be permitted to install or operate such equipment.
2. Always be certain that the primary and secondary circuits are de-energized before attempting any maintenance.
3. For maximum safety, only insert a completely assembled drawout breaker into an energized cell. Front covers and inter-pole barriers are safety features and must be in place when energized.
4. Always ensure that drawout circuit breakers are in one of four designed positions: "Connect", "Test", "Disconnect" or "Withdrawn". A circuit breaker permitted to remain in an intermediate position could result in control circuits being improperly connected causing other equipment to malfunction.
5. Do not remove access covers unless the circuits to be exposed are de-energized.
6. Use calibrated test equipment of known reliability to confirm that all circuits are de-energized before servicing.
7. After maintenance, be certain every current transformer secondary circuit is completely connected or shorted.

**DANGER**

**IF THE SECOND CIRCUIT OF ANY CURRENT TRANSFORMER IS LEFT OPEN WITHOUT LOAD, AND ITS PRIMARY CIRCUIT IS ENERGIZED, A DANGEROUSLY HIGH VOLTAGE IS DEVELOPED ACROSS TRANSFORMER SECONDARY TERMINALS. TO PREVENT DEATH, BODILY INJURY OR ELECTRICAL SHOCK, EITHER DE-ENERGIZE THE CIRCUIT BY OPENING THE BREAKER, OR SHORT CIRCUIT CURRENT TRANSFORMER SECONDARY TERMINALS, BEFORE PROCEEDING WITH MAINTENANCE.**

8. Always be certain that all assembly hardware is in place and bolted tightly before inserting a drawout circuit breaker into its compartment.

**WARNING**

**FAILURE TO FOLLOW THESE DIRECTIONS COULD RESULT IN DEATH, SERIOUS BODILY INJURY OR PROPERTY DAMAGE.**

#### 1.4 QUALIFIED PERSONNEL

For the purpose of operating switchgear assemblies, a person who has been thoroughly trained in the operation of the circuit breakers and any included instrumentation and who has complete knowledge of the loads connected to the assembly may be considered to be a qualified person.

For the purpose of installing, inspecting and maintaining switchgear assemblies, a qualified person must ALSO be thoroughly trained in regard to the hazards inherent to working with electricity and in the proper way to perform such work. The individual should be able to de-energize, clear and tag circuits in accordance with established safety practices. In addition, the individual should be equipped with, and trained in the use of, protective equipment (rubber gloves, flash clothes, etc.) for those occasions when it is not possible to de-energize all circuits before doing maintenance work in the area.

#### 1.5 PRECAUTIONS

1. If relays are included, remove all blocking. Check control circuits (except voltage and current transformer circuits) for grounds and short circuits before applying control power.
2. Connect the assembly to the station ground before applying any power.
3. In case of fire, do not use liquid fire extinguisher until all circuits have been disconnected.
4. If an indoor assembly is to be stored prior to installation, it must be protected from the weather and kept free of condensation.
5. If an outdoor assembly is to be stored prior to installation, provisions must be made for energizing the space heaters to prevent condensation of moisture inside the assembly.

## 1.6 OTHER PUBLICATIONS AND DOCUMENTATION

In addition to this instruction manual, other printed information and documentation is supplied with each assembly. This additional information will include, but not necessarily be limited to, a Magnum DS Low-Voltage Power Circuit Breaker instruction manual, arrangement drawings, and connection diagrams.

## SECTION 2: RECEIVING, HANDLING AND STORAGE

### 2.1 GENERAL INFORMATION

Magnum DS Metal-Enclosed Low-Voltage Switchgear assemblies are shipped in one or more shipping groups, depending on the number of vertical sections, or the limitations of handling facilities at the installation site. This would usually be up to five vertical sections for an indoor assembly, or up to three or four sections for an outdoor assembly.

Indoor shipping groups are secured by lag bolts to wooden skids that extend beyond all sides of the switchgear. All shipping sections are shipped so as to be protected from the weather during shipment but are not suitable for storage outdoors as shipped. Outdoor assemblies are not weatherproof until completely assembled. Treat them the same as indoor equipment until fully assembled.

### 2.2 RECEIVING

When a switchgear assembly reaches its destination, the purchaser should check the material received against the shipping list to be certain that all items have arrived. Note accurately any discrepancies. Each shipping group is plainly marked with or accompanied by an identifying shop order number, general order number and shipping weight. Each shipment includes a contents list which is a part of the overall package of shipping papers. To avoid the loss of any parts, the contents of each container should be carefully checked against the packing list. Do not discard any packing material until it is certain that every item has been received in the proper condition and that certain packing material will not be required later for equipment storage. Larger items, such as indoor traveling lifters, are shipped in separate cartons. Other loose and unmounted items may be packed in the same box as the lifter (Figure 2-1). These items, such as shipping split hardware, should be logged in and set aside in a safe location until the assembly has been set in its final position.

Equipment shipped from the factory is carefully packed and inspected prior to its departure. On occasion, however, equipment damage is incurred during transportation. If any damage is found, file a damage claim immediately with the transportation carrier and notify a Cutler-Hammer representative. All claims should be filed as soon as possible and include applicable part numbers, shop order numbers and/or general order numbers.

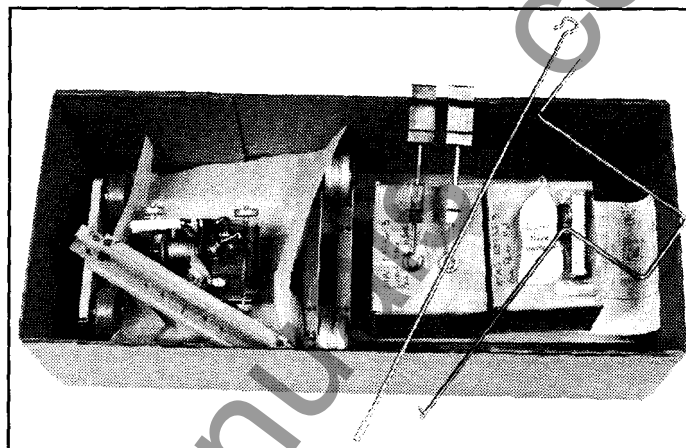

Figure 2-1 Carton Containing Indoor Lifter Assembly

### 2.3 PRECAUTIONS

It is preferable to use an overhead crane when moving the assembly. Circumstances at the installation location may prevent the use of an overhead crane for all movement. In such instances, the careful use of rollers can be employed. Although the methods for moving indoor and outdoor assemblies are similar, the techniques vary slightly. The differences are highlighted in this section.

#### 2.3.1 OVERHEAD LIFTING

**Indoor Assemblies:** For ease of handling by crane, each indoor shipping group is equipped with a lifting angle that extends the length of the shipping group. The lifting angle is designed and placed such that a spreader bar is not required between the lifting cables (Figure 2-2). Spreader bars can, however, be used if the overhead space is limited for crane use.

**Outdoor Assembly:** Lifting plates are attached along the assembly base at the front and rear for crane cable attachment. The methods used for lifting an outdoor assembly are similar to those used with an indoor assembly, except that spreader bars, not provided, must be placed between lift cables to prevent equipment damage (Figure 2-3). If it appears that the cables will touch the assembly during the lifting process, place appropriately sized lumber along the sides where contact could be made between the cable and the equipment. This will prevent damage caused by the lifting cables.

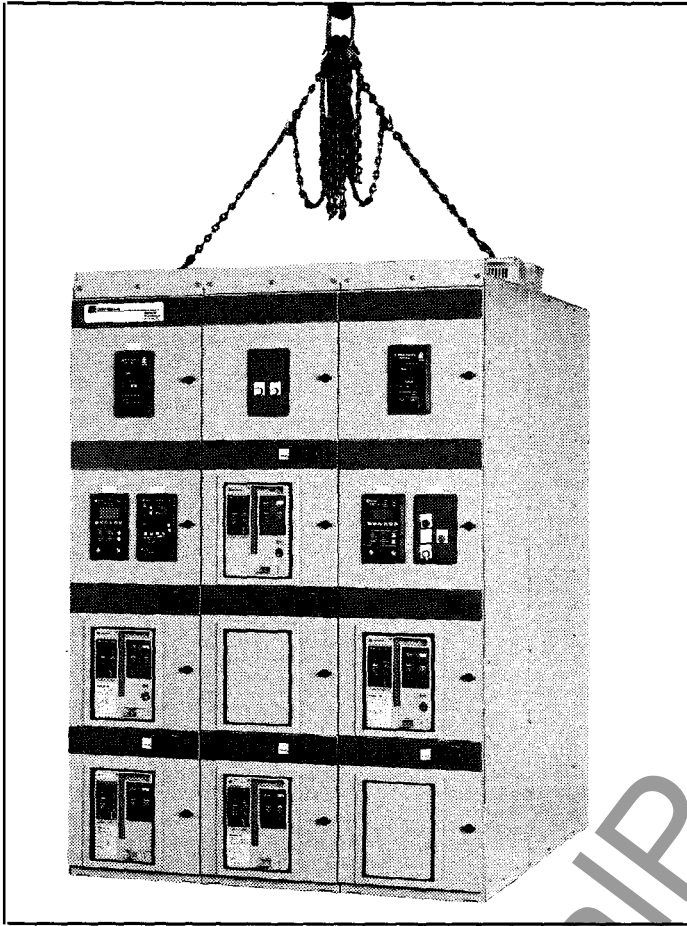

Figure 2-2 Indoor Assembly Lifting Method

### 2.3.2 ROLLING

If during the moving and positioning process it is not feasible to use an overhead crane, the equipment can be moved on construction rollers. The shipping skids on indoor assemblies or the heavy steel base on outdoor assemblies are used directly when rolling. If conditions are such that the indoor assemblies cannot be rolled into position with the shipping skids in place, they may be removed before rolling the assemblies. For best results, however, the shipping skids should be used. Use no less than four evenly spaced rollers for assembly movement. Since equipment length can vary, each 1.5 to 2.0 feet (457 to 610 mm.) of equipment length requires a roller. As the equipment is carefully moved, the rollers that become free at the end opposite the movement direction should once again be placed at the front for continued movement (Figure 2-4).

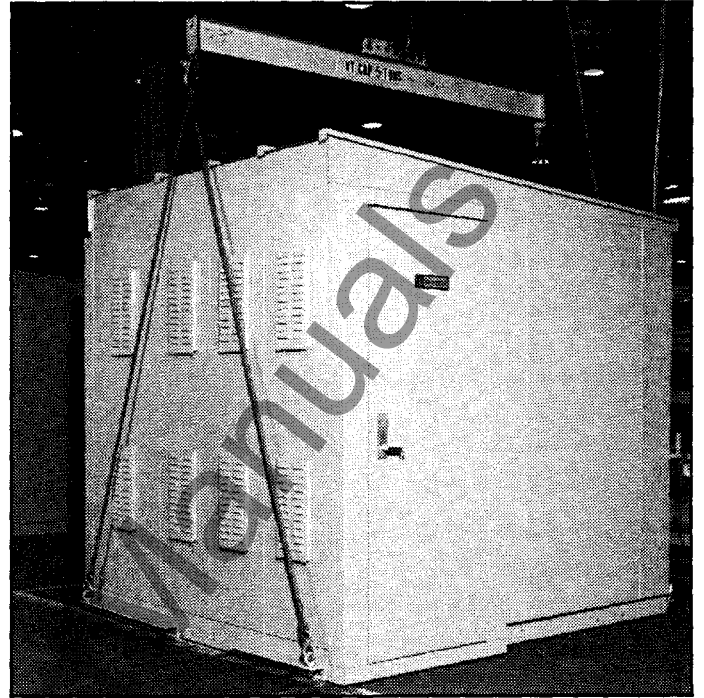

Figure 2-3 Outdoor Assembly Lifting Method

### 2.3.3 SHIPPING SKID AND LIFTING PLATE REMOVAL

The wooden shipping skid bolted to the bottom of an indoor assembly should be removed once the indoor assembly is in its permanent location. Lag bolts attach the shipping skids to the assembly from the inside. The holes that remain after the skids and lag bolts are removed are used in securing the indoor assembly permanently in position (Figure 2-5).

Once an outdoor assembly is in its permanent location remove the lifting eyes from the angles (Figure 2-6). Rotate the angles 180 degrees and reinstall. Use the angles to bolt the assembly to the foundation.

## 2.4 STORAGE

An indoor switchgear assembly which cannot be installed and put into service immediately should be stored in a dry and clean place, preferably indoors in a heated building. Conditions such as dampness, changes in temperature, dirty or corrosive atmospheres should be carefully avoided. Special precautions are required if the indoor assembly is to be stored outdoors. The assembly must be kept clean, well ventilated, and warm enough to prevent condensation. It will be necessary to cover the assembly and install temporary heating equipment.

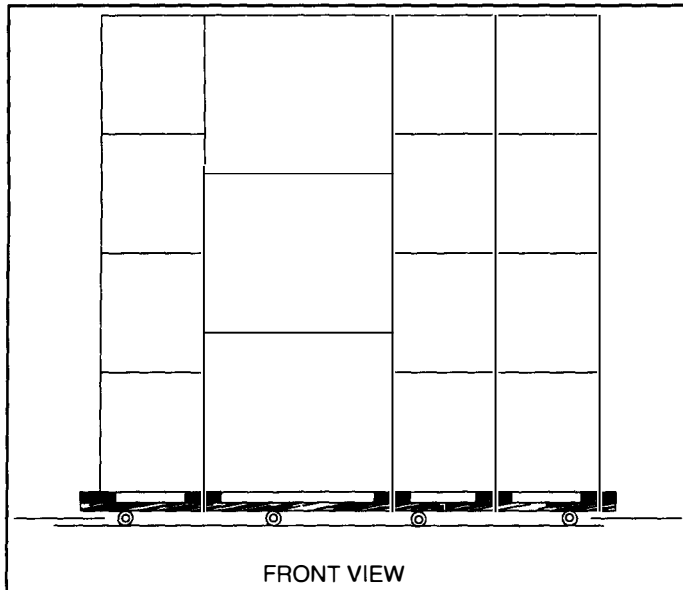

Figure 2-4 Assembly Rolling Procedure

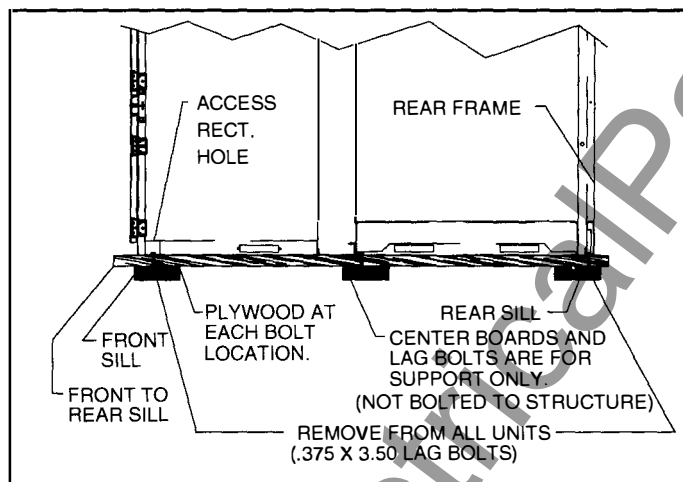

Figure 2-5 Shipping Skid

Approximately 250 watts per vertical section are required for average conditions. Outdoor storage of indoor equipment, even for a brief period, is not recommended and should be avoided. The covering provided during shipment for indoor assemblies is **NOT** adequate for outdoor storage. Covering must be adequate to protect the assembly from dust and falling debris, but loose enough to permit adequate ventilation. Place blocking on the roof of the equipment to keep covering material from restricting the air flow.

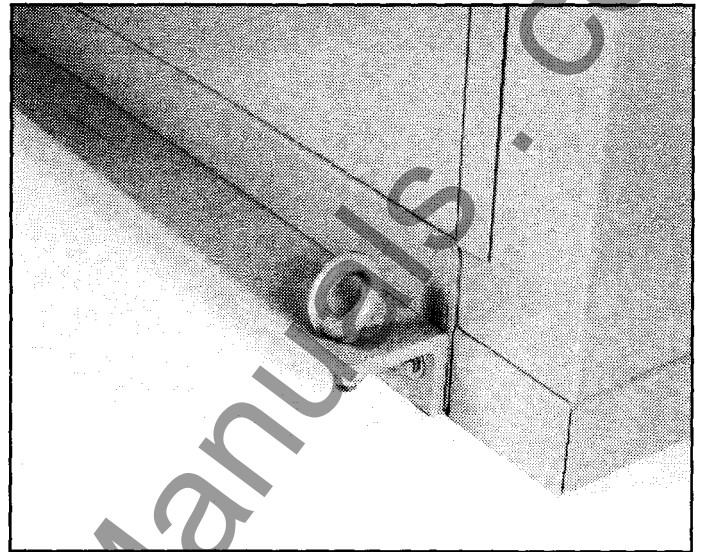
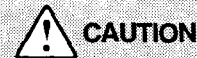

Figure 2-6 Lifting Angle in Place on Outdoor Assembly

A fully assembled outdoor assembly requires a minimum of care during outdoor storage. The area should be reasonably free of dirt and corrosive gases. The space heaters, which are standard with weatherproof assemblies, must be energized to prevent condensation.

Outdoor assemblies which are not fully assembled must be treated in the same manner as indoor equipment.



**CARE MUST BE TAKEN THAT INTEGRAL CONTROL POWER TRANSFORMERS ARE NOT BACK-FED. DISCONNECT PRIMARY AND SECONDARY FUSES.**

During storage, all assemblies, whether indoor or outdoor, should be placed on a firm, level surface. This will prevent any unnecessary strain or possible distortion.

Store all other separately packaged accessory equipment in a clean, dry location. It is recommended that a water-proof cover be placed over drawout circuit breaker cartons and the cartons kept in an indoor storage location when the circuit breakers are stored separately from the assembly.

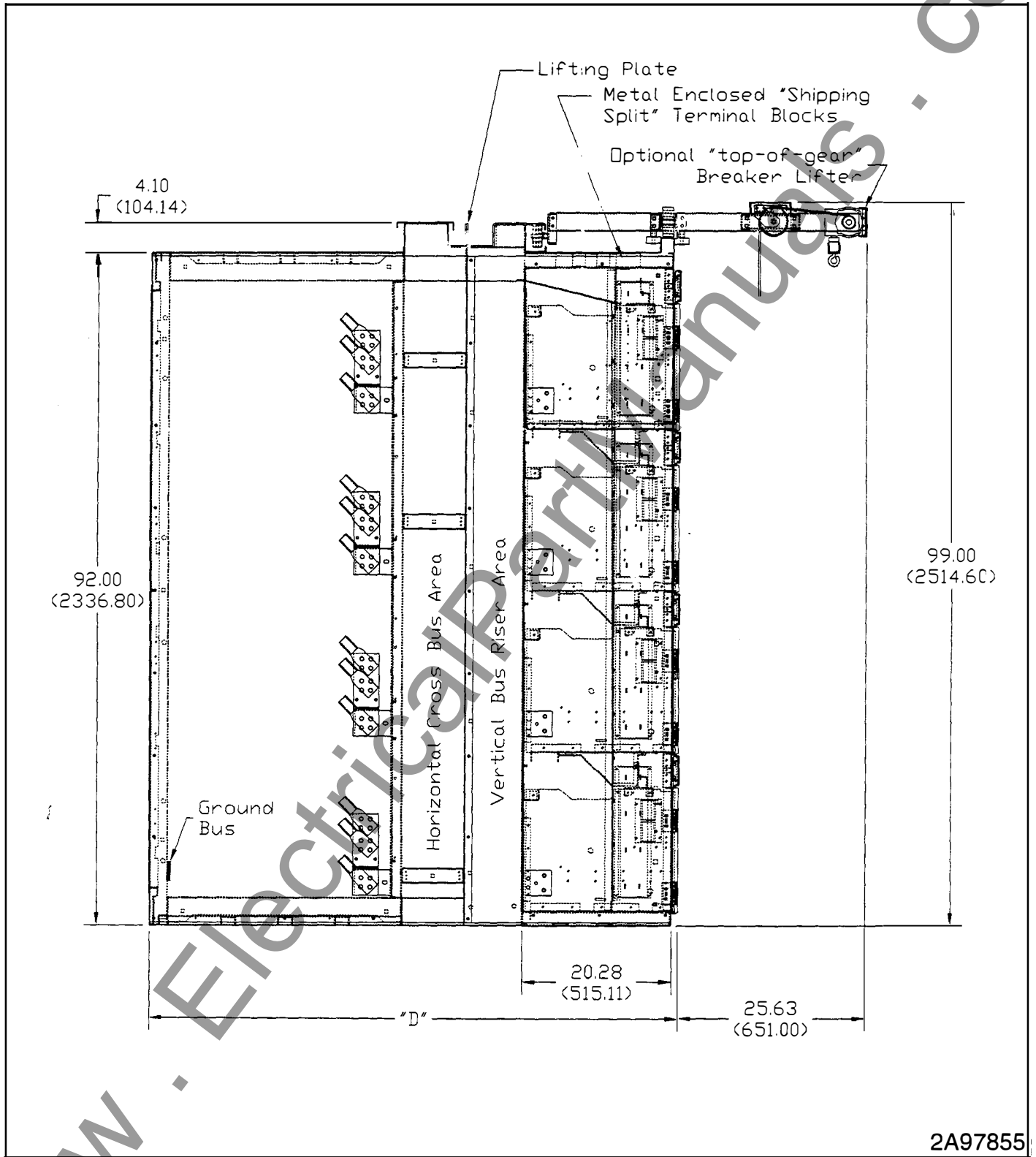

Figure 3-1 Four High Vertical Section (Side View)

## SECTION 3: EQUIPMENT DESCRIPTION

### 3.1 GENERAL DESCRIPTION

The following descriptions apply to standard metal-enclosed construction and wiring. Special features and control schemes are often incorporated. These special features are evident on the drawings and diagrams for the specific switchgear assembly. Instructions on standard apparatus such as relays, instruments, control switches and circuit breakers are included elsewhere in separate instruction books or sheets.

Each low-voltage (600 Volts and below) indoor and outdoor metal-enclosed switchgear assembly is factory assembled and tested. It is designed to require a minimum amount of labor for installation.

The switchgear assembly consists of a stationary structure that includes one or more free-standing vertical sections mechanically and electrically joined to make a single coordinated installation. Each vertical section consists of three major parts: front compartment, bus compartment, and cable compartment (Figure 3-1).

Type Magnum DS metal-enclosed switchgear assemblies are available for both indoor (NEMA Type 1) and outdoor (NEMA Type 3R) applications. The circuit breakers and design features are similar whether the installation be indoor or outdoor. An outdoor metal-enclosed switchgear assembly is constructed by assembling an outdoor enclosure around a standard indoor switchgear assembly.

Modifications can be made to the NEMA 1 enclosure for use in drip resistant or sprinkler resistant environments. When this is the case, these parts are shipped separately to reduce the risk of damage during shipping and handling. Installation instructions are given in drawing included in the information packet attached to the side of the switchgear assembly. Should additional copies of this drawing be needed, contact your nearest Cutler-Hammer sales office.

### 3.2 FRONT COMPARTMENT

The front compartment is a bolted steel structure. This structure may be an auxiliary unit used to house instruments, relays, switches and their associated auxiliary equipment or it may be divided into a maximum of four individual cells used to house circuit breakers (Figure 3-2). These individual cells may also be used as instrument cells by omitting the circuit breaker and its associated stationary parts. The hinged door then becomes available for mounting instruments, relays, etc.



Figure 3-2 One High Magnum DS Breaker in Connected Position

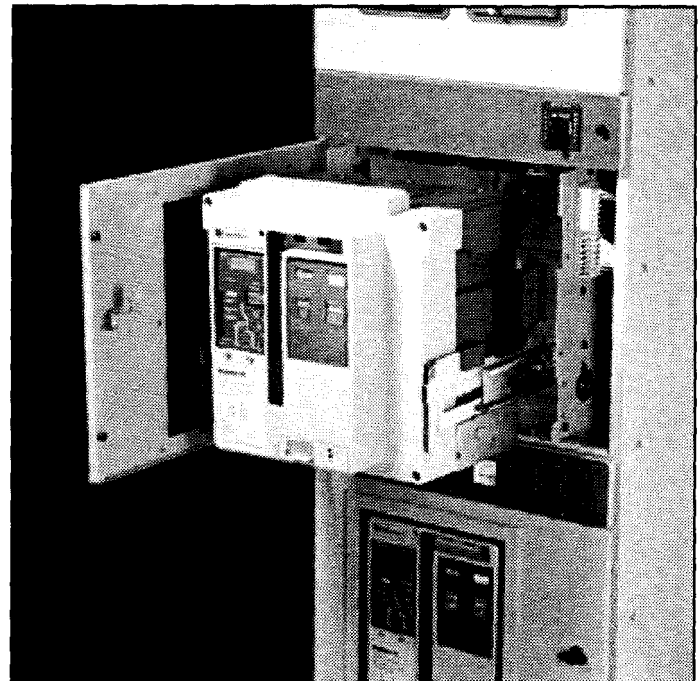

Figure 3-3 Magnum DS Breaker on Extension Rails

Above each breaker cell exists a compartment that contains terminal blocks and control wiring for connections to circuit breaker's secondary terminals and other devices. Breaker control devices and instrumentation may be mounted on the door defining this compartment.

### 3.2.1 BREAKER CELLS

In cells equipped for circuit breakers, a bolted-in cassette with extension rails supports the breaker (Figure 3-3). The cassette provides the mounting for the stationary secondary control disconnecting contacts and is located in the top/front region of the breaker cell (Figure 3-4). These provide the control circuit interface to the circuit breaker. In addition, the cassette provides the stationary ground contact for the circuit breaker, the truck operated switch (cell switch), and shorting terminal blocks for cell mounted instrument current transformers. A molded glass polyester plate at the rear of the breaker cell provides mounting for the instrument class current transformers.

The breaker cell provides three positions for the circuit breaker identified as "connect", "test" and "disconnect". Each specific position is indicated by the position indicator on the circuit breaker as it moves into and out of the cell. The "withdrawn" position is attained when the circuit breaker is removed from the cell with the extension rails fully extended.

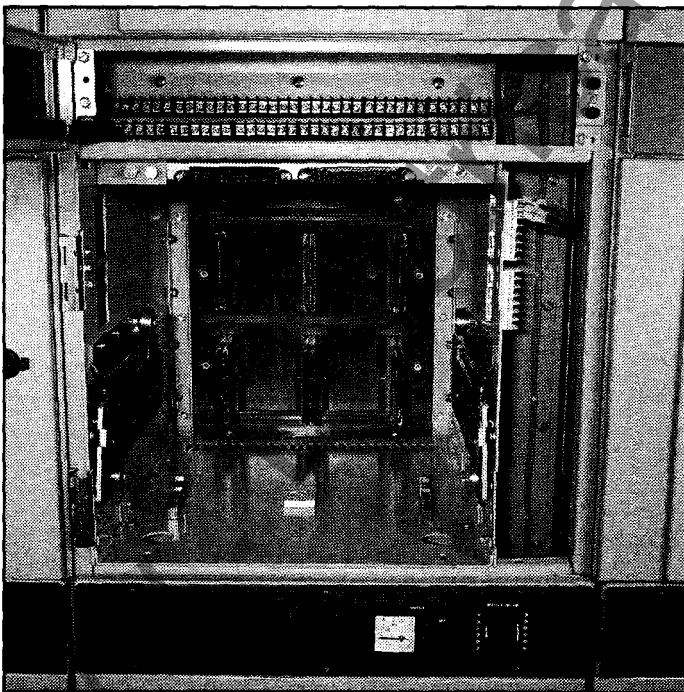

Figure 3-4 Magnum DS Breaker Cell

In the "connect" position, both the primary and secondary contacts are engaged and the circuit breaker is ready for operation. In the "test" position, only the secondary control contacts are engaged and the circuit breaker can be operated electrically without energizing the power circuit. In the "disconnect" position, both the primary and secondary control contacts are disengaged and the entire circuit breaker is isolated. Unlike the "connect" and "test" positions, the circuit breaker is not held captive in the cell in the "disconnect" position.

With the extension rails pushed in, the door can be closed with the breaker located in the "connect", "test" and "disconnect" positions.

When the levering device, located on the circuit breaker, is moved to the "disconnect" position the circuit breaker can then be freely withdrawn out of the cell.

#### 3.2.1.1 BREAKER CASSETTE

The breaker cassette supports the breaker in the cell and on the movable extension rails as the breaker is placed into the cell. The cassette also contains the following features:

##### 3.2.1.1.1 EXTENSION RAILS

The extension rails are withdrawn from the breaker cassette by pulling the black handles located on the end of the extension rails. Once extended, the breaker is placed onto the draw-out rails by aligning the hook features located on each side of the circuit breaker housing with the slotted features in the draw-out rails. The breaker is then pushed into the cell until it reaches a positive stop.

##### 3.2.1.1.2 BREAKER INTERFERENCE INTERLOCKS

800, 1600, 2000 and 3200 Ampere circuit breakers have the same dimensions. To prevent insertion of circuit breakers with mismatching features, insufficient interrupting ratings, or incorrect frame size into cells, interference interlocks are provided.



**DO NOT DISABLE AN INTERFERENCE INTERLOCK. USING A LOWER CAPACITY BREAKER MAY RESULT IN A VIOLENT ELECTRICAL FAULT AND CAUSE DEATH, OTHER BODILY HARM AND SEVERE EQUIPMENT DAMAGE.**

These interference interlocks are steel pins located on the floor of the breaker cassette. As the breaker is pushed into the cell, the mating pins on the breaker bottom moves past a set of corresponding pins on the breaker cassette. If the breaker is not matched correctly for the cell, the pins will not clear each other and the breaker will not travel to the disconnect position.

<b>BREAKERS WHICH WILL FIT CELL IN EMERGENCIES</b>	
<b>BREAKER CELL</b>	<b>EMERGENCY SITUATION</b>
MDS-408	MDS-608, MDS-616, MDS-620, MDS-808, MDS-816, MDS-820, MDS-C08, MDS-C16, MDS-C20
MDS-608 MDS-616 MDS-620	MDS-608, MDS-616, MDS-620, MDS-808, MDS-816, MDS-820, MDS-C08, MDS-C16, MDS-C20
MDS-808 MDS-816 MDS-820	MDS-808, MDS-816, MDS-820, MDS-C08, MDS-C16, MDS-C20
MDS-C08 MDS-C16 MDS-C20	MDS-C08, MDS-C16, MDS-C20
MDS-632	MDS-832, MDS-C32
MDS-832	MDS-C32
MDS-C32	NONE



**CAUTION**

**IN EMERGENCY SITUATIONS THE BREAKER LISTED ON THE RIGHT WILL FIT THE CELL LISTED ON THE LEFT. HOWEVER, DO SO ONLY IF TRIP UNIT CAN BE ADJUSTED TO PROTECT THE COMPLETE CIRCUIT.**

Table 3-1 Emergency Usage of Breakers

**3.2.1.2 KEY INTERLOCKS**

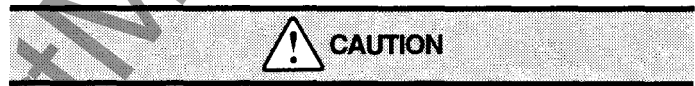
Key interlocks are supplied when it is necessary to ensure the proper sequence of operation between two or more circuit breakers or between a circuit breaker, fuse truck or transformer high voltage disconnect switch. The interlock mechanism provided in a circuit breaker cell functions by keeping the breaker cell trip-free. The key interlock mechanism is located on the wire way side of the circuit breaker. The breaker can be removed, inserted, or a different breaker installed and the cell will remain trip-free. The key interlock operates by pulling the slide forward, rotating the key, and removing it from the lock. The slide mechanism actuates a lever located on the circuit breaker, which prevents the breaker from being closed. The key can then be used in another location. The cell will remain trip-free until the key is put back into the lock, rotated, and the slide retracted.



**TO FACILITATE MANUFACTURE AND INSTALLATION PROCEDURES, A KEY IS SUPPLIED WITH EACH LOCK. BEFORE PLACING A SWITCHGEAR ASSEMBLY WITH KEY INTERLOCKS IN OPERATION, THE KEY SCHEME MUST BE CAREFULLY CHECKED, AND ONLY THE PROPER KEYS LEFT IN THE LOCKS. ALL EXTRA KEYS MUST BE REMOVED AND DESTROYED OR STORED WHERE NOT AVAILABLE TO OPERATING PERSONNEL. THIS PROCEDURE IS NECESSARY SINCE THE IMPROPER USE OF SPARE KEYS WILL DEFEAT THE INTERLOCKING SCHEME.**

**3.2.1.3 METERING CURRENT TRANSFORMERS**

When required for metering, current transformers are positioned around the stationary main contacts (Figure 3-4). Holes are provided in the main contact support insulation for mounting front accessible current transformers. See table for metering accuracies.

Short circuiting terminal blocks are provided as standard for each set of current transformers.

**DANGER**

**IF THE SECONDARY CIRCUIT OF ANY CURRENT TRANSFORMER IS LEFT OPEN WITHOUT LOAD, AND ITS PRIMARY CIRCUIT IS ENERGIZED, A DANGEROUSLY HIGH VOLTAGE IS DEVELOPED ACROSS TRANSFORMER SECONDARY TERMINALS. TO PREVENT DEATH, BODILY INJURY OR ELECTRICAL SHOCK, EITHER DE-ENERGIZE THE CIRCUIT BY OPENING THE BREAKER, OR SHORT CIRCUIT CURRENT TRANSFORMER SECONDARY TERMINALS, BEFORE PROCEEDING WITH MAINTENANCE.**

Current Transformer Metering Accuracy Metering Type Current Transformers for Mounting in Circuit Breaker Cells								
Breaker Frame Rating	Ratio	Ratio	B-0.1	B-0.2	B-0.5	B-0.9	B-1.8	
800, 1600, 2000	100/5	100/1	2.4	—	—	—	—	
	150/5	150/1	1.2	2.4	—	—	—	
	200/5	200/1	1.2	2.4	2.4	—	—	
	250/5	250/1	0.6	1.2	2.4	—	—	
	300/5	300/1	0.6	0.6	1.2	2.4	—	
	400/5	400/1	0.3	0.6	1.2	1.2	—	
	500/5	500/1	0.3	0.3	0.6	1.2	2.4	
	600/5	600/1	0.3	0.3	0.6	1.2	1.2	
	750/5	750/1	0.3	0.3	0.3	0.6	1.2	
	800/5	800/1	0.3	0.3	0.3	0.6	1.2	
	1000/5	1000/1	0.3	0.3	0.3	0.6	0.6	
	1200/5	1200/1	0.3	0.3	0.3	0.6	0.6	
	1500/5	1500/1	0.3	0.3	0.3	0.6	0.6	
	1600/5	1600/1	0.3	0.3	0.3	0.6	0.6	
	2000/5	2000/1	0.3	0.3	0.3	0.6	0.3	
	3200	1600/5	1600/1	0.3	0.3	0.6	0.6	1.2
2000/5		2000/1	0.3	0.3	0.3	0.6	0.6	
2400/5		2400/1	0.3	0.3	0.3	0.3	0.6	
2500/5		2500/1	0.3	0.3	0.3	0.3	0.3	
3000/5		3000/1	0.3	0.3	0.3	0.3	0.3	
3200/5		3200/1	0.3	0.3	0.3	0.3	0.3	
3500/5		3500/1	0.3	0.3	0.3	0.3	0.3	
4000/5		4000/1	0.3	0.3	0.3	0.3	0.3	
4000	4000/5	4000/1	0.3	0.3	0.3	0.3	0.3	
5000	5000/5	5000/1	Refer to Cutler-Hammer					

Table 3-2 Current Transformer Metering Accuracy

**3.2.1.4 CELL SWITCH**

An optional cell switch is operated by movement of the circuit breaker between the “connect” and “test” positions. It is mounted at the rear of the breaker cell. A lever connected to the switch shaft is actuated by the frame of the breaker as it moves into or out of the “connect” position. As a result, the cell switch can be used to electrically indicate whether or not the breaker is in the “CONNECT” position.

Its most common uses are for disconnecting remote control circuits to electrically operated breakers, and for bypassing “b” interlocking auxiliary contacts when a breaker is withdrawn from the connected position.

**3.2.1.5 SPACE HEATERS**

Space heaters are furnished as standard equipment in outdoor switchgear assemblies to eliminate condensation. Heaters are placed at the rear of the “D” position breaker cell, the bottom of bus compartment and the bottom of the cable compartment. As an option, space heaters can be installed in indoor equipment.

**3.2.1.6 SHUTTERS**

Shutters covering the primary contacts are supplied on an optional basis. The shutter is operated as a circuit breaker is moved into and out of the cell. These are provided to prevent accidental contact with live bus.

**DANGER**

**DO NOT ATTEMPT TO ACTIVATE SHUTTERS MANUALLY! SHUTTERS ARE ONLY INTENDED TO BE OPERATED BY THE CIRCUIT BREAKER. ALL POWER SHOULD BE TURNED OFF PRIOR TO INSPECTING SHUTTERS. FAILURE TO DO SO COULD RESULT IN DEATH, SERIOUS BODILY INJURY OR PROPERTY DAMAGE.**

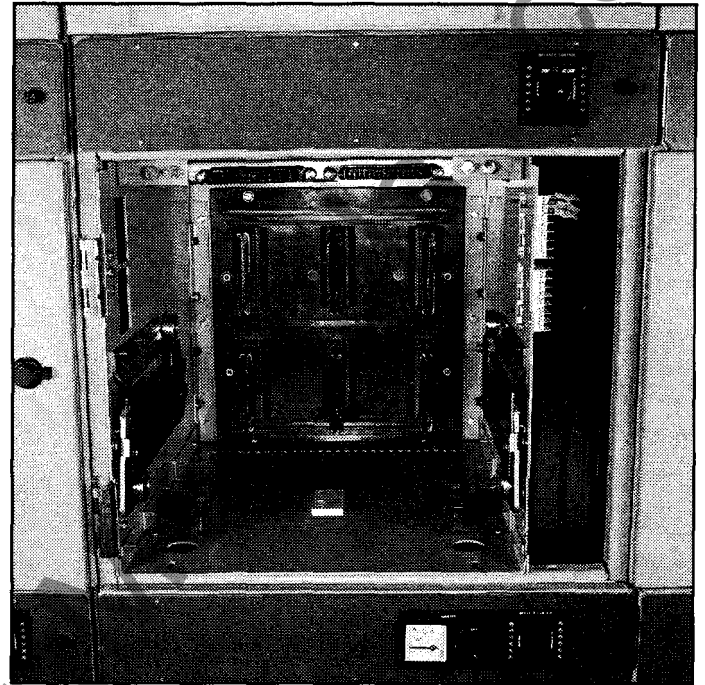

Figure 3-5 Secondary Disconnect Terminal Compartment

**3.2.2 SECONDARY TERMINAL COMPARTMENT**

Above each breaker cell is a narrow door (Figure 3-5). Control wiring entering or leaving the cell is connected to terminal blocks in the area behind this door. This area provides mounting for up to 72 termination points. Factory connections are made on the rear side of these terminal blocks. Field connections are made along the front surface of these terminal blocks by hinging the terminal block cover down. A screw type terminal landing is provided. See Figure 3-6 for secondary disconnect terminal arrangement.

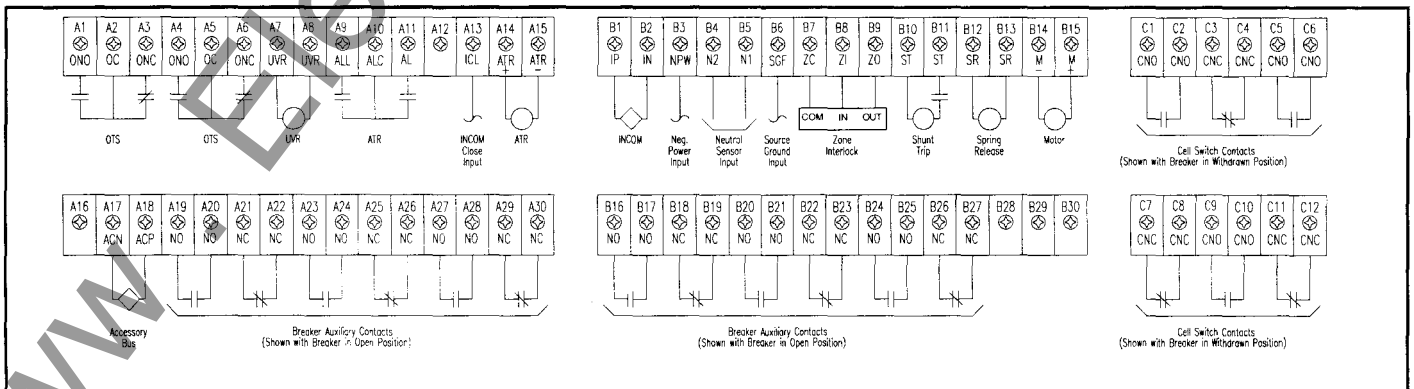

Figure 3-6 Secondary Disconnect Terminal Arrangement

### 3.2.3 CONTROL WIRING

The standard wire used in Switchgear Assemblies is Type SIS stranded copper, No. 14 AWG. For communication wire, No. 18 AWG shielded with 600 volt insulation is used.

Field installed control wiring is to enter the enclosure in the bus compartment for top entry and in the breaker compartment base for bottom entry as shown in Figure 3-8. The right side of the front compartment has been reserved for field wiring to run from top to bottom. For top entry field control wiring, an enclosed wiring trough is provided to run wiring forward. When the wiring exits the wiring trough it can then be transitioned vertically to the appropriate breaker cell by tying to the vertical plane provided. Lances punched into this plane provide placement of wire ties for securing wire bundles.

The control conduit cover plates for top (Figure 3-7) and bottom entry are removable. Once removed, these plates can then be punched for the appropriate conduit size.

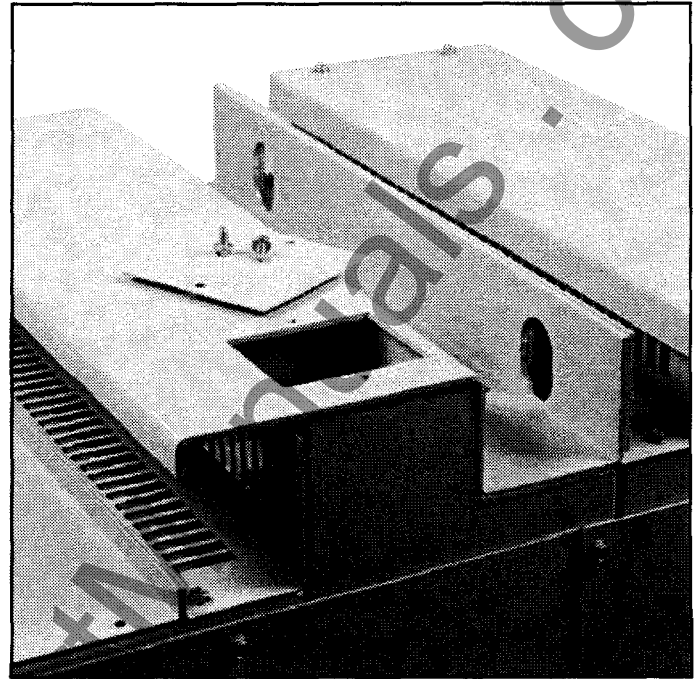

Figure 3-7 Top Conduit Cover Plate

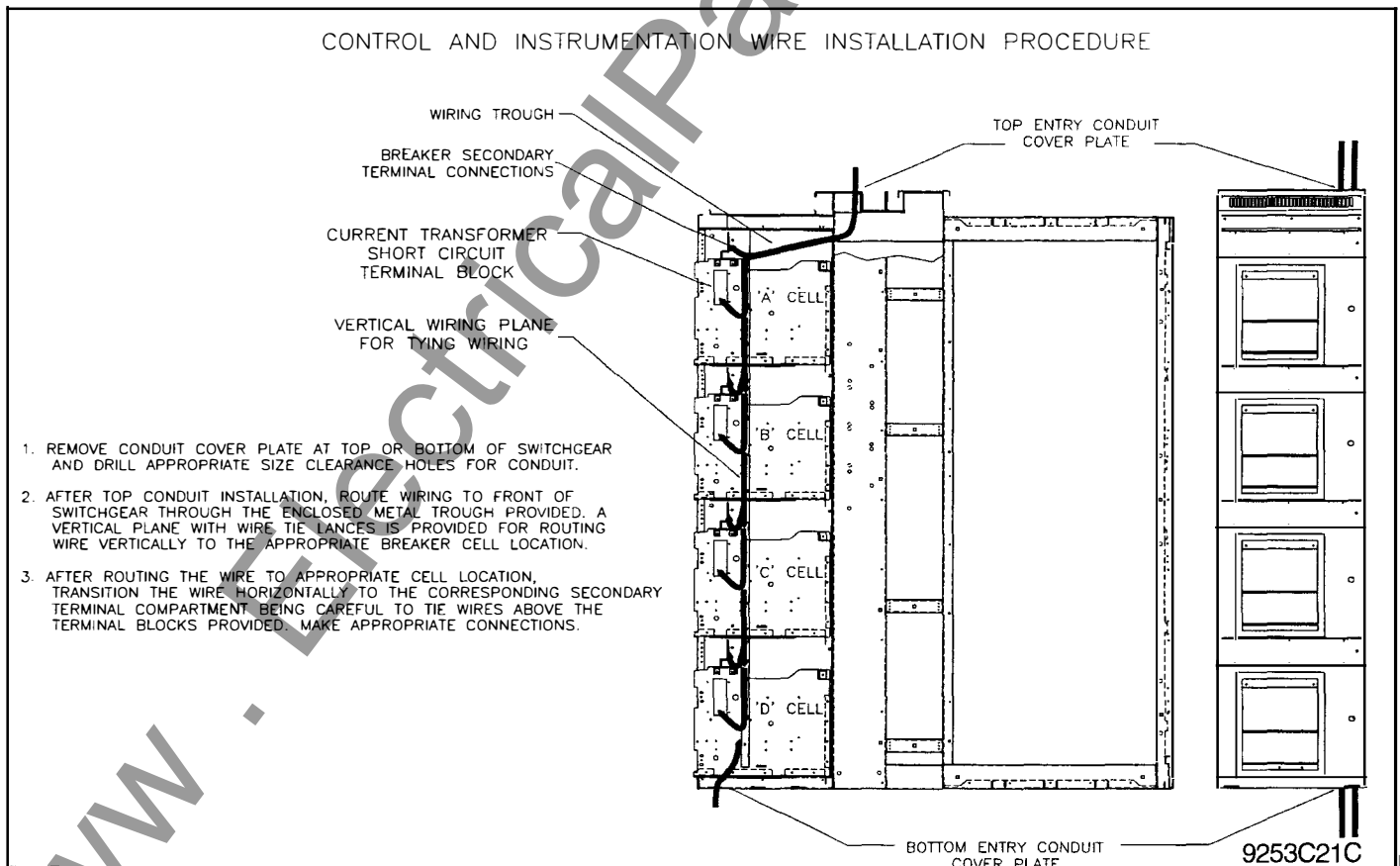

Figure 3-8 Field Installed Control Wiring

### 3.2.4 AUXILIARY COMPARTMENT

Auxiliary compartments are normally the same physical size as a circuit breaker cell. They are used to house and mount instruments, control components and other auxiliary devices. The compartment has a hinged front door that is used for mounting a variety of devices (Figure 3-9).

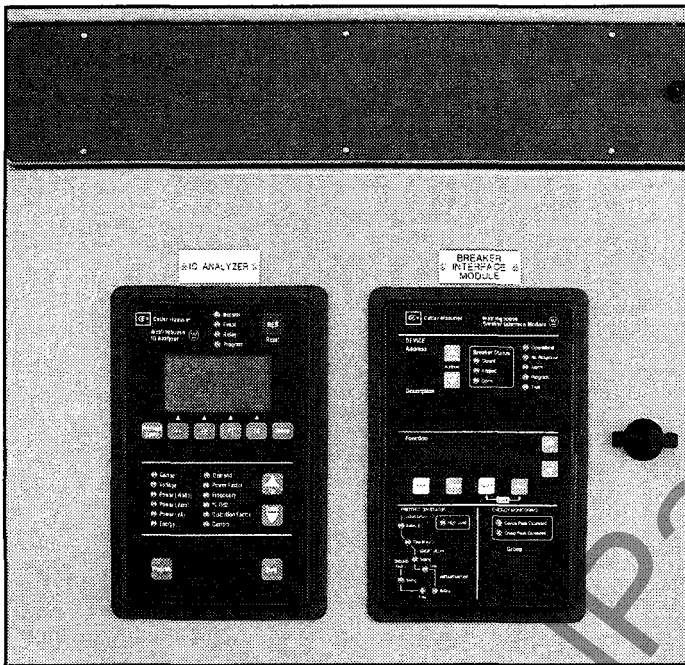

Figure 3-9 Auxiliary Compartment Door

### 3.2.5 AUXILIARY/TRANSITION SECTION

Full height auxiliary sections with hinged front doors or transition sections with bolted covers are provided for a variety of reasons; (1) additional bus space needed for matching up to different equipment assemblies; (2) close coupling to transformer; (3) mounting and wiring of additional control equipment. These vertical sections can be 11, or 22 inches (279 or 559 mm.) wide, depending upon the need and application.

### 3.3 BUS COMPARTMENT

The bus compartment provides space for vertical and horizontal bus. The compartment is located just behind the front compartment and is fully isolated from breaker and auxiliary cells. (See Figure 3-1) In addition, optional grounded steel barriers are placed between the bus and rear cable connections, providing an additional degree of safety. This helps prevent accidental contact with the main bus during maintenance procedures.

The horizontal main bus ties the vertical sections together electrically; the vertical bus feeds the individual breaker compartments. Bus sizing is based on ANSI standard temperature rise criteria of 65 Degrees C over 40 Degrees C ambient. All bus meets industry standard phase-to-phase clearance without utilizing insulated bus. Standard main and section bus is silver-plated copper with tin-plated copper optional.

### 3.4 CABLE COMPARTMENT

The cable compartment is located behind the bus compartment and provides sufficient room for easy cable installation. Bus bars extend the line or load side of the stationary disconnecting contacts into the cable compartment. Lug landings will accept compression or mechanical lugs. They are mounted on a 45 degree angle, up or down, to facilitate cable termination with minimum bending (Figure 3-10). On four-wire systems, an isolated neutral bus extends the length of the line-up and includes a tap for outgoing neutral cable for each feeder breaker.

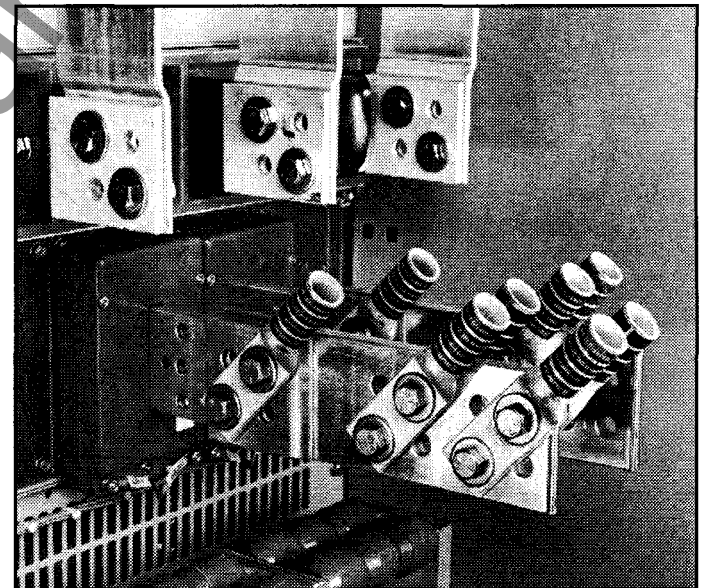

Figure 3-10 Load Runbacks with Lug Adapters

### 3.5 GROUND BUS

A permanent, low-resistance ground connection is essential for safe operation. A terminal for the connection to the station ground is provided in the service entrance section.

The ground bus is located at the bottom rear of the cable section and includes terminals for customer's connections (Figure 3-11).

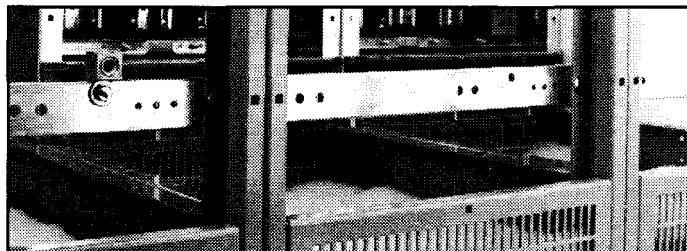

Figure 3-11 Ground Bus in Cable Compartment

### 3.6 OUTDOOR ENCLOSURE TYPE 3R

The Magnum DS outdoor design is the indoor design enclosed in a separate outdoor enclosure (Figure 3-12). The rigid structure foundation base is easily anchored to a pad using the supplied lifting/tie down angles. A separate channel base is not required.

A front operating and maintenance aisle extends through all units of the assembly. A large reinforced door with panic hardware is standard at each end of the aisle. These doors can be opened from the inside, even when pad-locked from the outside. The rear access doors are hinged and provided with door stops. These braces keep the doors open at a 90 degree angle.

The outdoor structure also includes, as standard, filtered ventilation openings (filters can be changed without opening aisle or rear compartment doors), aisle lighting, GFI protected convenience receptacles and space heaters. When specified, a thermostat is mounted in the cable

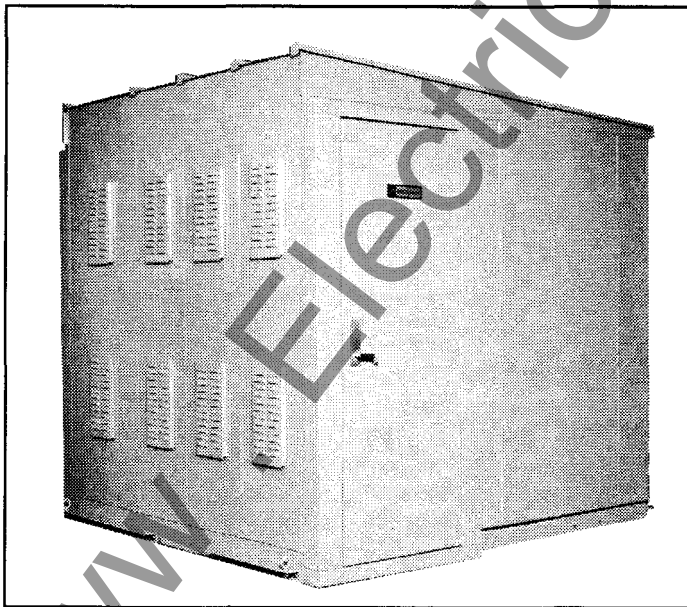

Figure 3-12 Outdoor Enclosure

compartment. Space heaters are located in the "D" position breaker cell, bus compartment and cable compartment of each vertical section.

### 3.7 TYPE MAGNUM DS CIRCUIT BREAKERS

Refer to Instruction Book 2C12060H01 for receiving, handling and storing, description and operation, installation, adjustments, and maintenance instructions. Circuit breaker data, and renewal parts information is also included.

### 4: INSTALLATION



**BEFORE PROCEEDING WITH ANY INSTALLATION, TESTING, START-UP OR MAINTENANCE, REVIEW ALL OF SECTION 1 FOR SAFETY PRACTICES AND RECOMMENDATIONS. FAILURE TO DO SO COULD RESULT IN DEATH, SERIOUS BODILY INJURY OR PROPERTY DAMAGE.**

#### 4.1 GENERAL INFORMATION

This section contains instructions for installing Magnum DS Metal-Enclosed Low-Voltage Switchgear Assemblies. Proper installation of Magnum DS Metal-Enclosed Low-Voltage Switchgear is of prime importance. Too much emphasis cannot be placed on this phase of the work. Study the associated instruction manuals and drawings carefully.

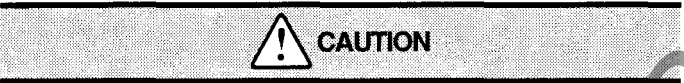

**PERSONNEL INSTALLING THIS EQUIPMENT MUST BE THOROUGHLY FAMILIAR WITH ALL ASSOCIATED INSTRUCTION MANUALS AND APPLICABLE GOVERNING**

**CODES. ADDITIONALLY, ALL DRAWINGS, WHETHER MECHANICAL OR ELECTRICAL, MUST BE UNDERSTOOD AND STRICTLY FOLLOWED TO PREVENT POSSIBLE DAMAGE TO THE SWITCHGEAR OR EQUIPMENT BEING PROTECTED.**

#### 4.2 LOCATION AND FOUNDATION

Magnum DS Metal-Enclosed Low-Voltage Switchgear is assembled at the factory on smooth level surfaces to assure correct alignment of all parts. Extra care by the purchaser in selecting the location and preparing the foundation will result in reduced installation costs, as well as good equipment performance.

##### 4.2.1 LOCATION

In general, the location will have been determined during the specification and/or procurement phases. Indoor locations impose certain requirements which must be met so that the switchgear assembly may operate efficiently with the least amount of maintenance. Consideration must be given to the aisle space required at the front and rear of the equipment, space at the ends of the lineup, and equipment ventilation (Figure 4-1). In addition to Figure 4-1, refer to floor plan drawings supplied as part of the equipment drawing package.

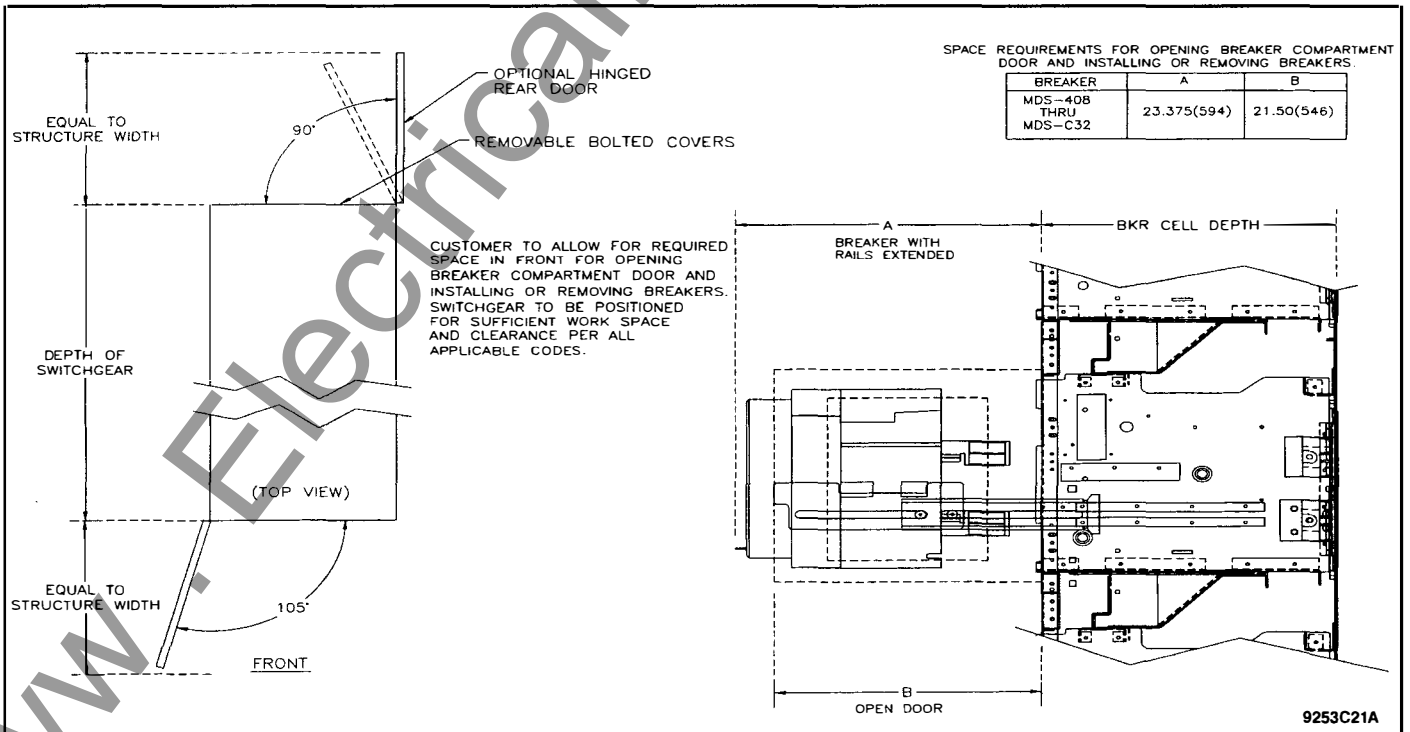

Figure 4-1 Typical Installation Space Requirements

The space at the front must be sufficient to permit the opening of doors, the insertion and withdrawal of circuit breakers, and the transfer of circuit breakers to other compartments by means of an overhead lifter or portable lifting device. The space at the rear must be sufficient to open rear doors, install cables, inspect equipment and perform maintenance.

Switchgear equipment should be placed in a clean, dry area, allowing air to freely circulate. The bus and cable compartments are ventilated by means of air entering the ventilation openings in the rear of the enclosure and leaving through a ventilator in the bus compartment roof.

**4.2.2 FOUNDATION**

The floor or foundation must be smooth, level (within 1/8 inch per three feet [3.5 mm./meter] in any direction) and strong enough to support the weight of the equipment without sagging. Table 4-1 outlines the approximate weights for various ratings of indoor and outdoor switchgear assemblies.

Actual weights will depend upon the amount of equipment in the individual sections. Adequate safety factors must be included in any weight calculation. If the foundation is subject to vibration and/or impact loads, special mounting considerations must take place to prevent the transmission of vibration or shock to the equipment.

**4.2.3 INDOOR EQUIPMENT**

The preferred method of anchoring an indoor assembly is by fastening it to level steel channels which are embedded in the concrete floor. Holes that remain after the wooded skids are removed from indoor assemblies are used for securing the assembly permanently in position. Four inch (5.4 lb./ft) structural channels are recommended as a minimum size for the average lineup of indoor equipment.



**THE FRONT AND REAR CHANNELS MUST BE SET AND ALIGNED WITH EACH OTHER AND MUST BE LEVEL (0.125" PER THREE FEET [3.5 MM./METER]) OVER THEIR ENTIRE LENGTH TO AVOID DISTORTION OF THE STRUCTURE. THE FINISHED FLOOR MAY HAVE A SLIGHT PITCH AWAY FROM THE CHANNELS BUT IN NO CASE SHOULD THE FINISHED FLOOR BE HIGHER THAN THE CHANNELS.**

Magnum DS Switchgear Structure Weights Weights in Lbs. (Kg) Approximate Dimension in inches (mm) Approximate		
<b>Indoor Switchgear Assemblies Less Breakers</b>		
Width	Depth	Weights
<b>BREAKER STRUCTURES</b>		
22 (558.8)	60-66 (1524-1676)	1300 (590)
22 (558.8)	72-78 (1829-1981)	1400 (635)
22 (558.8)	84-90 (2133-2286)	1500 (680)
44 (1117.6)	60-66 (1524-1676)	1500 (680)
44 (1117.6)	72-78 (1829-1981)	1600 (726)
44 (1117.6)	84-90 (2133-2286)	1700 (771)
<b>AUXILIARY STRUCTURES</b>		
22 (558.8)	60-66 (1524-1676)	1000 (454)
22 (558.8)	72-78 (1829-1981)	1100 (499)
22 (558.8)	84-90 (2133-2286)	1200 (544)
44 (1117.6)	60-66 (1524-1676)	1100 (499)
44 (1117.6)	72-78 (1829-1981)	1200 (544)
44 (1117.6)	84-90 (2133-2286)	1300 (590)
<b>TRANSFORMER TRANSITION STRUCTURES</b>		
22 (558.8)	60-90 (1524-2286)	1000 (454)
<b>BUSSED TRANSITION STRUCTURES</b>		
11 (279.4)	60-66 (1524-1676)	500 (318)
<b>Drawout Breaker Element ①</b>		
MDS-408		130 (59)
MDS-608		130 (59)
MDS-808		145 (66)
MDS-C08		145 (66)
MDS-616		130 (59)
MDS-816		145 (66)
MDS-C16		145 (66)
MDS-620		145 (66)
MDS-820		145 (66)
MDS-C20		145 (66)
MDS-632		175 (80)
MDS-832		175 (80)
MDS-C32		175 (80)
MDS-840		310 (141)
MDS-C40		310 (141)
MDS-850		310 (141)
MDS-C50		310 (141)

① Impact weight equals 1.5 times breaker static weight.

Table 4-1 Switchgear Weights

Each unit is fastened to the floor channels by either bolting or welding. Welding is a quick and easy method of securing the switchgear assembly in place, while eliminating the layout of the mounting holes in the channels.

#### 4.2.4 OUTDOOR EQUIPMENT

Outdoor assemblies do not require floor channels. Hold down plates are provided by rotating the lifting angles 180 degrees and then permanently bolted to the foundation. As was the case with the indoor foundation, the outdoor foundation should also be level from front to rear and side to side to prevent distortion. For further details see the foundation plans provided with the equipment.

#### 4.2.5 CONDUITS

Provisions must be made in the foundation for all conduits entering from below. Specific floor plan details provided with the equipment must be used to determine the final conduit layout, spacing of floor channels, and floor space required for each lineup (Figure 4-2).

Power conduits should project above the finished floor not more than two inches (51 mm) for an indoor assembly. Control wire conduits should not extend higher than 1 inch (25 mm). It will simplify moving the groups into place if the conduits are flush with the concrete surface and appropriate extension sleeves added after the units are in their final location. See the floor plan information supplied with the assembly for conduit space and location.

#### 4.3 SHIPPING GROUP ASSEMBLY

Before assembling the switchgear equipment, all components should be available at the site location. The prepared foundation should be ready and all embedded conduits installed and capped.

##### 4.3.1 ASSEMBLY PROCEDURES

When correctly installed, both indoor and outdoor assemblies should conform to the following requirements:

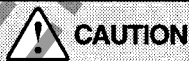

**CAUTION**

**PRIOR TO INSTALLATION AND ASSEMBLY, BE CERTAIN THE FOUNDATION IS LEVEL AND FREE OF ANY DEBRIS TO PREVENT EQUIPMENT DAMAGE.**

1. Front panels should form a straight line. When transformers and/or other gear are included, equipment should be located in keeping with the plan drawings supplied with the equipment.
2. Vertical sections must be correctly spaced from center to center and plumb. A suggestion for lining up the shipping groups is to establish a base line a few inches in front of the switchboard and parallel to the final location. Equalize the distances from the front of the shipping groups to the base line, thus making the face of the assembly parallel to the base line. Check each vertical section by dropping a plumb line from the top corner of each vertical section. It should align with the bottom corner.
3. The entire assembly of vertical sections should be securely fastened to floor channels or base pad.
4. Shipping groups must be securely bolted together and all bus and control wiring connections properly made.

After the first shipping group has been located, the second shipping group should be moved into position and similarly checked. The shipping groups are fastened together in accordance with the instructions given in drawing 9253C18. This drawing is included in the information packet attached to the side of the switchgear assembly. Should additional copies of this drawing be needed, contact your nearest Cutler-Hammer sales office.

#### 4.4 BUS, CABLE AND CONTROL CONNECTIONS

##### 4.4.1 BUS CONNECTIONS

All connections of the main and neutral buses, and the ground bus at shipping breaks are made by means of bolted splice plates. These are always plated, bolted joints. Required hardware and splice plates are provided. Provision is made at the ends of the lineup, not adjacent to transformers, for future expansion by means of bolted bus joints.

See drawing 9253C18 for typical shipping split cross bus and neutral installation instructions. This drawing is included in the information packet attached to the side of the switchgear assembly. Should additional copies of this drawing be needed, contact your nearest Cutler-Hammer sales office.

##### 4.4.2 BUS JOINT PREPARATION

The bolting areas of all bus materials are plated to provide a reliable joint. In some atmospheres the plating will become tarnished, but this does not reduce its effective-

Floor Plan/Conduit Area

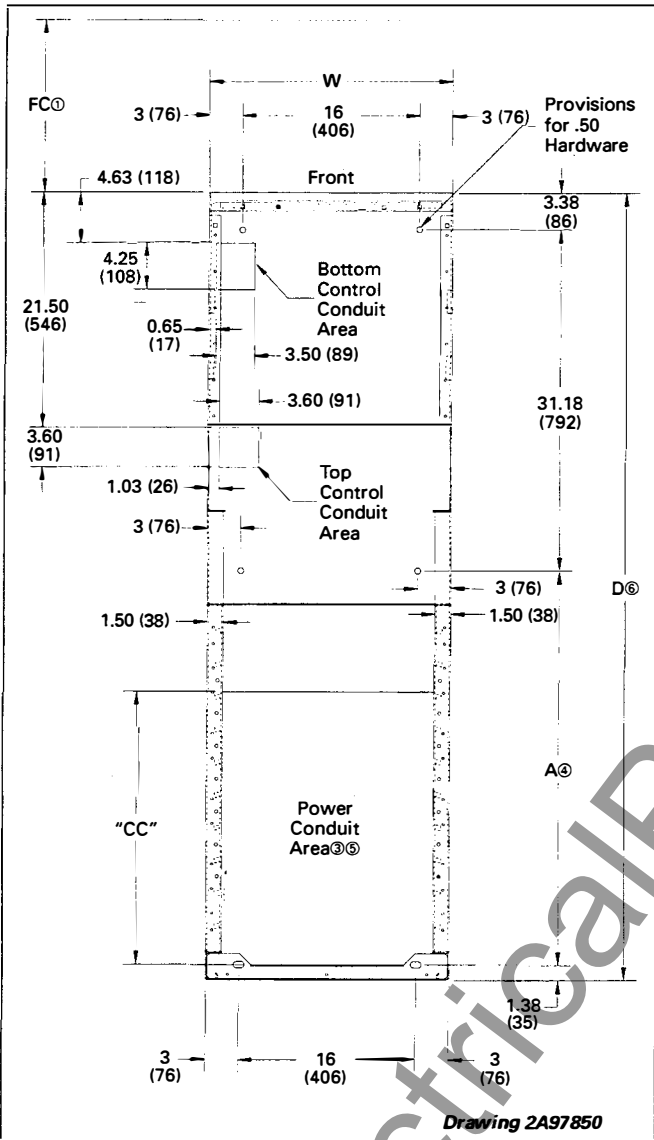

Drawing 2A97850

- ① FC is the recommended front clearance for breaker removal with top-of-switchgear-mounted breaker lifter. If a portable breaker lifter is to be used, allow at least 84 inches (2134 mm) of aisle space.
- ② When a zero-sequence ground-fault CT is mounted on line-side or load-side of a breaker, reduce CC dimension by 10 inches (254 mm).
- ③ Stub conduit 2 inches (50 mm) maximum in power cable area, 1 inch (25 mm) maximum in control wiring area.
- ④ Bolt hole location for mounting the center floor channel when required. Floor channels not included.
- ⑤ For available area for bus duct connection contact Cutler-Hammer.
- ⑥ Hinged rear doors add 1.25 inches (32 mm).

Dimensions, in Inches (Millimeters)

FC①	W	D⑥	A④	CC②	Recommended Number of Power Conduits (Maximum)③	
					3.5-Inch	4-Inch
36 (914)	22 (559)	60 (1524)	24 (611)	13.3 (338)	6	6
		66 (1676)	30 (764)	19.3 (490)	9	9
		72 (1829)	36 (916)	25.3 (643)	12	12
		78 (1981)	42 (1069)	31.3 (795)	15	15
		84 (2134)	48 (1221)	37.3 (948)	18	18
36 (914)	44 (1118)	60 (1524)	24 (611)	13.3 (338)	12	12
		66 (1676)	30 (764)	19.3 (490)	18	18
		72 (1829)	36 (916)	25.3 (643)	24	24
		78 (1981)	42 (1069)	31.3 (795)	30	30
		84 (2134)	48 (1221)	37.3 (948)	36	36
		90 (2286)	54 (1373)	43.3 (1100)	42	42

Center of Gravity Location

Center of Gravity	
For seismic calculations, the following dimensions should be used to locate the center of gravity for Indoor Magnum DS Switchgear:	
Vertical . . . . .	60 inches (1524 mm)
Left-to-right . . . . .	center of lineup
From the front . . . . .	26 inches (660 mm)

Magnum DS Power Conduit Layouts

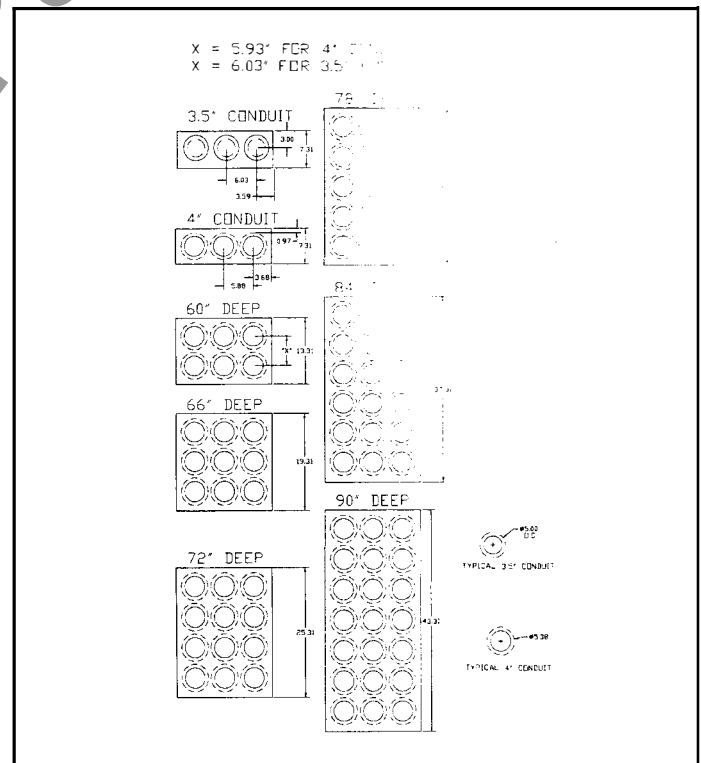

2A97849

Fig. 4-2 Indoor Equipment Location of Anchor Points and Conduit Location

ness. Dirt grease and other foreign material must be removed from the surfaces before they are joined. For dirty surfaces use a lint-free, water-dampened cloth. If this does not produce satisfactory results, use a lint-free cloth dampened with a mild solvent such as mineral spirits, Stoddard solvent or isopropyl alcohol. Again, wipe it dry after cleaning.

 **CAUTION**

**THE MILD SOLVENTS DESCRIBED ARE FLAMMABLE. PROVIDE ADEQUATE VENTILATION AND KEEP AWAY FROM FLAMES AND OTHER IGNITION SOURCES. CONSULT YOUR SAFETY DEPARTMENT BEFORE USING. NO SOLVENT IS SAFE IN AN UNVENTILATED AND POORLY VENTILATED SPACE.**

**4.4.3 BOLT TIGHTNESS**

All fasteners holding structural members, barriers and covers are installed at the factory tight enough to assure rigidity of the assembly and to prevent rattling of the covers after the equipment is energized. When covers or barriers are removed during installation, care should be taken to solidly tighten all bolts after replacing.

Bolts installed in bus joints and connections are high strength steel, SAE Grade 5. The reliability of current conducting joints is dependent upon the tightness of the joint. Therefore, extreme care must be taken when making or remaking bus joints in the field to assure their tightness. Bolts in bus connections should be tightened according to Table 4-2.

TORQUE FOR BOLTS IN BUS BAR JOINTS (USING GRADE 5 STEEL BOLTS)	
BOLT SIZE	TORQUE FT/LBS (NEWTON/METERS)
3/8 - 16	20 (27)
1/2 - 13	50 (65)

Table 4-2 Bolt Tightness For Bus Connections

**4.4.4 GROUND BUS**

The joint in the ground bus is made by means of a single splice plate bolted directly to the inside of the rear steel frame (Figure 3-11). It is important that the ground bus be connected first since it provides an integral ground for all the equipment. It must be connected to the station ground before energizing equipment.

Terminals are provided on the ground bus for connection to the station ground. This connection should be a direct connection and not run in metal conduit. The grounding conductor should be capable of carrying the maximum line-to-ground current for the duration of the fault.

 **DANGER**

**A PERMANENT, LOW-RESISTANCE GROUND IS ESSENTIAL FOR ADEQUATE PROTECTION. A POOR GROUND COULD BE WORSE THAN NONE, SINCE IT GIVES A FALSE FEELING OF SAFETY TO THOSE WORKING AROUND THE EQUIPMENT. IMPROPERLY GROUNDED EQUIPMENT COULD RESULT IN DEATH, BODILY INJURY OR PROPERTY DAMAGE.**

**4.4.5 POWER CABLE LASHING**

Each switchgear assembly is provided with either crimp or mechanical lug landings arranged so that the lugs are pointed up or down at a 45 degree angle to reduce the cable bending required for installation. (Figure 4-3).

Cable lashing is not required for 1600, 2000 and 3200 ampere circuit breaker frames at short circuit currents at or below 65kA if the installation methods given in (A) and (B) are followed. At short circuit currents above 65kA the guidelines given in Figure 4-4 should be followed. For 800 ampere circuit breaker frames at all short circuit currents cable lashing methods given in Figure 4-4 should be followed.

To assure the short circuit ratings of the switchgear the following cable lugs are to be used for power cables:

**A) COMPRESSION CRIMP LUGS**

- 1) Two mounting holes.
- 2) Minimum of double crimp.
- 3) Must be crimped with hydraulic crimper with minimum of 12 tons (11 metric tons) compression.

**B) MECHANICAL SCREW LUGS**

- 1) Aluminum body lug with two mounting holes.
- 2) One 1/2" hex cable holding screws torqued to 500 in. lbs. (56.5 Newton/Meters).

When the above lugs or installation methods are not used follow the cable lashing instructions given in Figure 4-4.

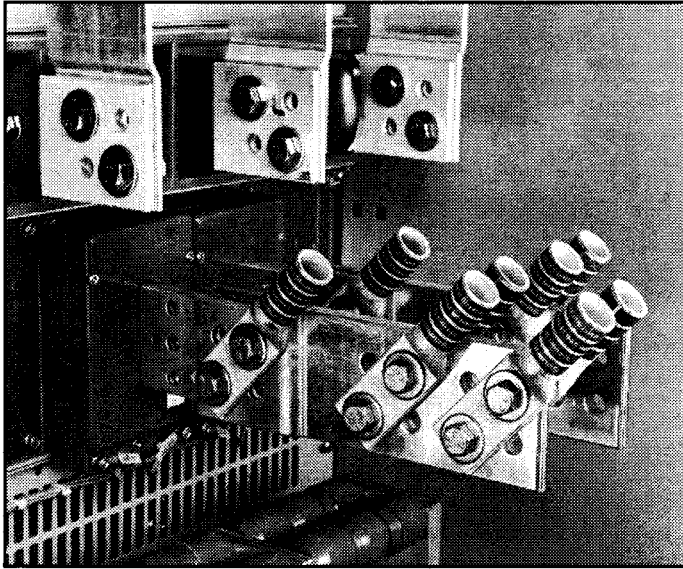

Figure 4-3 Lug Landings

**4.4.6 CONTROL CONNECTIONS**

All control wiring that connects between two shipping sections must be reconnected to their correct points on the terminal blocks located on top of the vertical sections as shown in Figure 4-5. These connection points are located beneath the top cover of the breaker compartment.

Male/female pull-a-part terminal blocks are utilized for shipping section control wiring connections. The connections are made by plugging the appropriate male pig-tail into the corresponding female connector. Control wiring should be checked with the connection diagram to ensure that all connections have been made properly, all fuses installed, current transformer circuits completed, and connections tightened.

Before applying control power, check all control circuits for grounds, except current and voltage transformer secondaries. Integrally supplied ac control sources are provided with a safety ground on the neutral side of 120 V circuits.

**CABLE LASHING IS NOT REQUIRED WHEN FACTORY SUPPLIED LUGS ARE INSTALLED AS INSTRUCTED IN PARAGRAPH 4.4.5. OTHERWISE THE FOLLOWING INSTRUCTIONS MUST BE FOLLOWED:**

TO INSURE THE SHORT CIRCUIT RATINGS OF THIS EQUIPMENT, CABLE LASHING IS NECESSARY FOR BREAKERS 2000 AMPS OR LESS WHEN THE LUGS LISTED IN PARAGRAPH 4.4.5 ARE NOT USED.

1. SHORT CIRCUIT RATINGS ABOVE 10KA REQUIRE ALL LINE AND LOAD CABLES, FOR 2000 AMP AND UNDER CIRCUITS. BE LASHED AS SHOWN BELOW.
2. THE FOLLOWING 3/8" DIA. 3 STRAND NYLON TWISTED ROPE MUST BE USED. SIZE #12, 3/8" DIA. WITH THE FOLLOWING MINIMUM STRENGTHS

TENSILE/BREAKING STRENGTH	WORKING LOAD
3340 LBS. [1515 KG]	278 LBS. [126 KG]

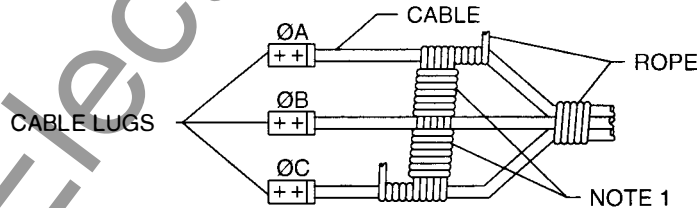

AFTER CABLE IS ROUTED AS CLOSE TOGETHER AS POSSIBLE, THE ROPE IS TO BE WRAPPED AROUND THE CABLE 6" [15 CM] FROM LUGS. SECOND WRAP IS TO BE APPLIED 6"[15 CM] FROM THE FIRST WRAP. EACH SET OF WRAPS CONTAINS 5 LOOPS.

NOTE 1: WHEN THE CABLE IS NOT COMPLETELY TOGETHER, ROPE WRAP SHOULD BE PLACED AROUND THE ROPE TO FIRM UP SUPPORTS.

Figure 4-4 Cable Lashing Instructions

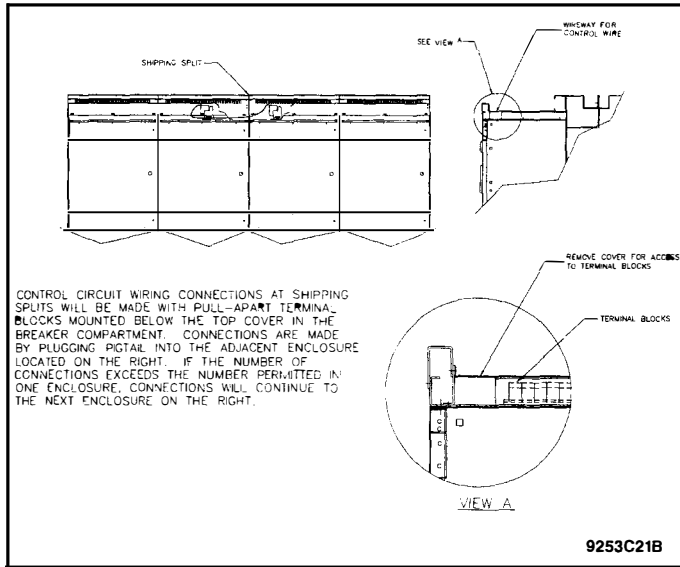

*Figure 4-5 Shipping Split Control Terminal Block Connection*

No grounds should be present on dc circuits. Make sure all circuits are clear and that any electrically operated circuit breakers are in the "remove" position.

If the control power source is other than a self-contained control power transformer, the conductors from the source to the assembly must be of adequate size to avoid excessive voltage drop during operation.

If the control power source is other than a self-contained control power transformer, the conductors from the source to the assembly must be of adequate size to avoid excessive voltage drop during operation.

#### 4.5 TRAVELING CIRCUIT BREAKER LIFTER

The traveling overhead circuit breaker lifter is a standard device installed on outdoor assemblies. Check to be certain that the carriage assembly moves freely across the entire length of the switchgear.

Indoor switchgear assemblies are supplied with overhead lifters as an optional item. When an optional lifter is supplied, it is shipped in a separate carton (Figure 2-1) with instructions for assembly.

In general, the installation of the lifter assembly is not difficult. Certain steps should, however, be carefully followed to ensure smooth operation.

For proper installation of the overhead breaker lifter follow the instructions in Figures 4-6 and 4-7. Figure 4-8 shows how to attach to the breaker for lifting.



**WARNING**

**DO NOT STAND UNDER THE CIRCUIT BREAKER DURING HOISTING OPERATIONS. THE CIRCUIT BREAKER MIGHT SLIP AND CAUSE PERSONAL INJURY. KEEP HANDS AND TOOLS AWAY FROM SPREADER BAR, LIFTING HOOKS AND BREAKER. SEVERE INJURY MAY RESULT. SUDDEN MOTIONS ARE COMMON IN A CABLE UNDER TENSION AS IT WINDS AROUND A WINCH DRUM.**

#### 4.6 MOVING PARTS

There are few moving parts in the stationary structures of switchgear assemblies. It is recommended that all moving parts be carefully operated by hand. This will ensure that no binding or damage has occurred during shipment or handling. In some cases accessories may be blocked or braced for shipment. Thoroughly check apparatus, such as meters and relays, for forms of blocking or bracing which must be removed.

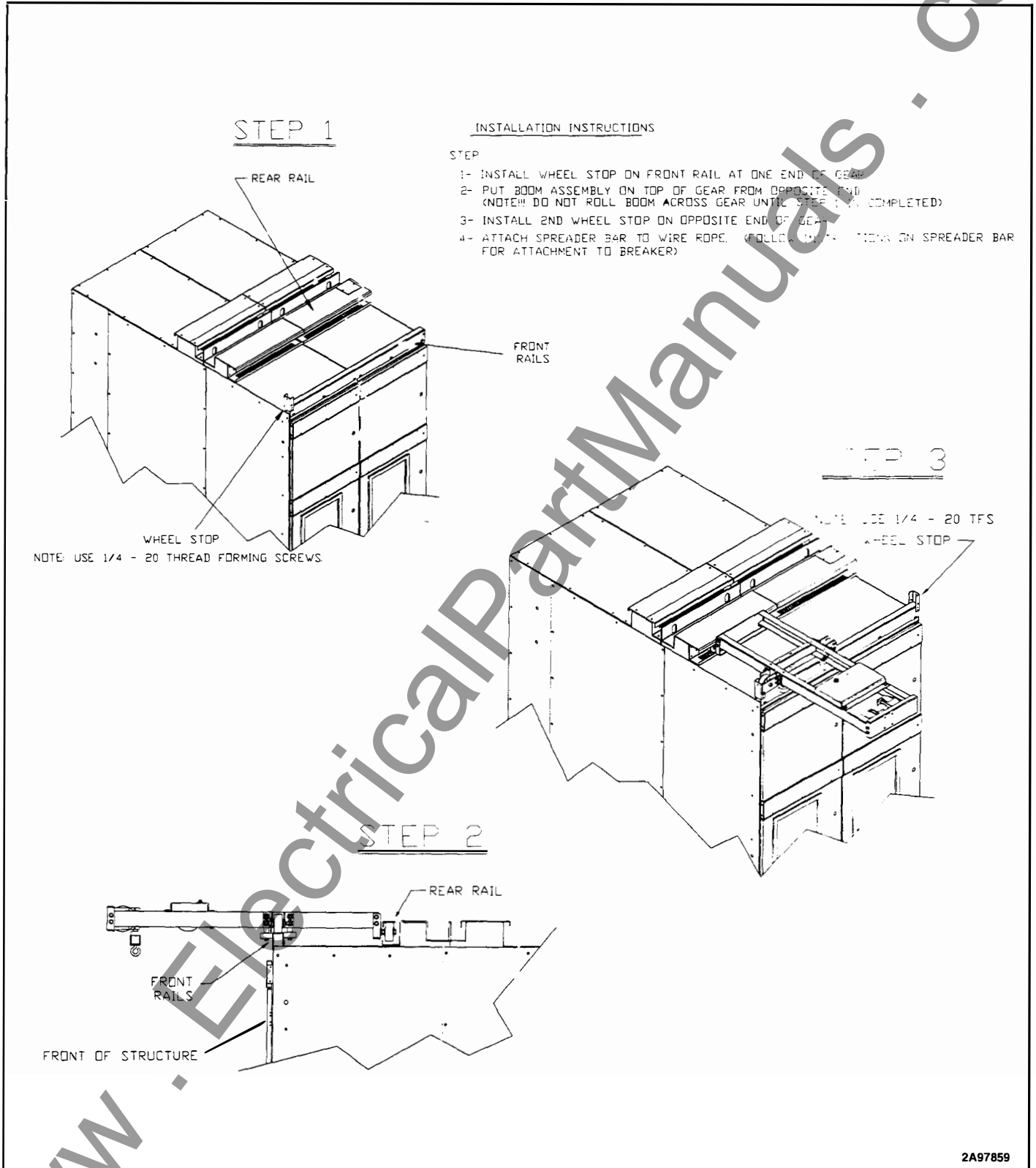

Figure 4-6 Breaker Lifter Installation

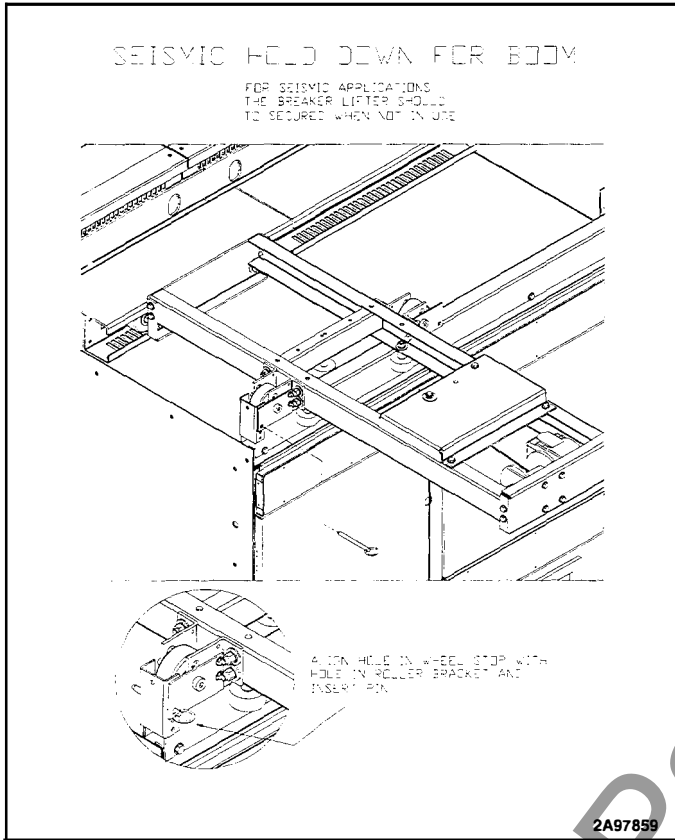

Figure 4-7 Breaker Lifter Installation

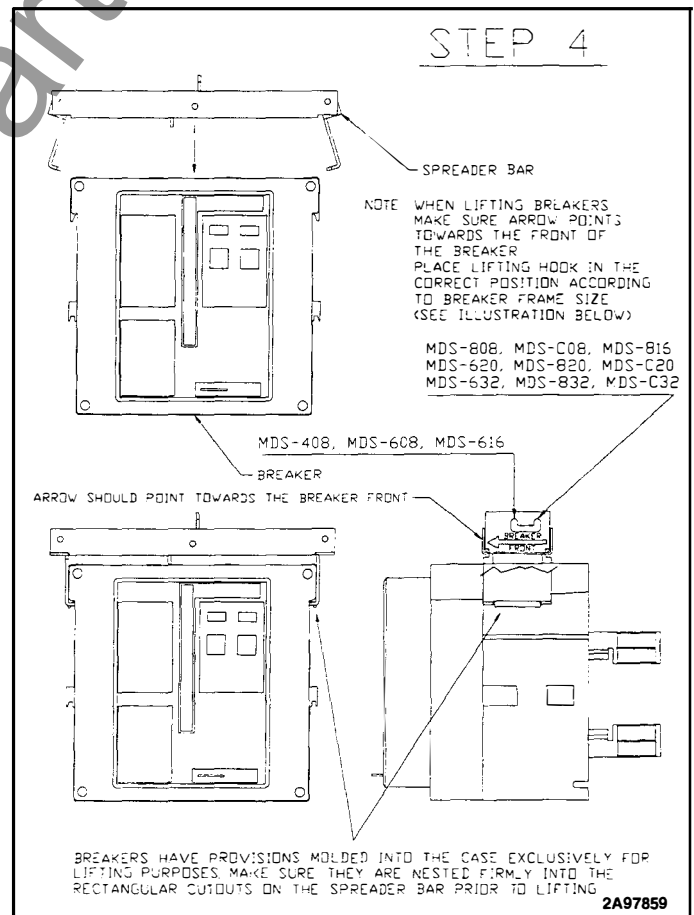

Figure 4-8 Hooking Arrangement for Lifting Breakers

**5: INSPECTION AND TESTING PRIOR TO OPERATION****DANGER**

**BEFORE PROCEEDING WITH ANY INSTALLATION, TESTING, START-UP OR MAINTENANCE, REVIEW ALL OF SECTION 1 FOR SAFETY PRACTICES AND RECOMMENDATIONS. FAILURE TO DO SO COULD RESULT IN DEATH, SERIOUS BODILY INJURY OR PROPERTY DAMAGE.**

**5.1 GENERAL INFORMATION**

After the switchgear assembly and apparatus to be controlled have been installed and all interconnections made, the equipment should be given a final check and tested before being placed in service. This is necessary to assure that the equipment has been correctly installed and that all connections are complete and have been made properly.

**DANGER**

**TO AVOID POSSIBLE DEATH, BODILY INJURY OR ELECTRICAL SHOCK, EXTREME CARE MUST BE EXERCISED TO PREVENT THE EQUIPMENT FROM BEING CONNECTED TO THE POWER SYSTEM WHILE THE PRELIMINARY TESTS ARE BEING CONDUCTED. IF DISCONNECTING SWITCHES ARE NOT AVAILABLE, LINE LEADS SHOULD BE DISCONNECTED TO ACCOMPLISH THIS NECESSARY STEP.**

Directions for testing relays, instruments, meters, circuit breakers and other electronic devices, which may be a part of the assembly, are given in the instruction book for each individual device. The proper settings for protective devices are normally determined from a coordination study performed by the purchaser or consultant. Factory settings were those used for production testing and do not reflect specific site requirements.

**5.2 TEST EQUIPMENT**

Test equipment will depend on the rating and type of installation. Portable voltmeters of the multi-scale type will be required. For larger installations, ammeters should be available in case unexpected circumstances arise. An ohmmeter and "megger" will prove invaluable in checking insulation and continuity of the circuits. A simple portable device for "ringing" or "lighting-out" circuits may be used for the continuity check.

**5.3 CONNECTIONS**

Wire connections, accessible bolted bus connections and barriers should be examined to be sure that they have not been loosened or damaged during shipment or installation.

The connections to equipment external from the switchgear assembly such as remote control, interlock circuits and auxiliary switches should be checked for continuity to ensure that they are also correct. There must be definite assurance that connections are correct before an attempt is made to operate the equipment.

Verify that all shipping split wiring has been correctly connected.

**5.4 AUXILIARY EQUIPMENT**

If space heaters are supplied, they should be energized to confirm correct operation.

Relays included on the instrument panels are normally set for production testing levels when shipped. The final settings of the relays should be coordinated with other parts of the system in accordance with the purchaser's standards or operation practice. Any necessary modifications to the relay settings should be carried out in accordance with the instruction leaflet for that particular relay.

All covers for meters, relays and other devices removed during testing, should be carefully handled when removed. The covers should be put back in place promptly to keep dust and dirt from collecting.

**5.5 GROUND FAULT SYSTEMS (PER THE NATIONAL ELECTRIC CODE)**

Ground fault protection of service entrance equipment shall be provided for solidly grounded wye electrical services of more than 150 volts to ground, but not exceeding 600 volts phase-to-phase for each service disconnecting means rated 1000 amperes or more. The ground fault protection system shall be performance tested when first installed on site. The test shall be conducted in accordance with instructions outlined in Section 230-95 of the National Electrical Code.

Performance testing of ground fault protection systems should be undertaken only by qualified personnel. In the tests requiring the use of high current test equipment, it is usually necessary to obtain the services of a qualified testing organization. See IB 32-693 for Magnum DS Breaker ground fault conformance testing.

## 5.6 CIRCUIT BREAKERS AND TRIP UNITS

All circuit breakers should be checked to be sure that they are in accordance with the requirements of the circuits. The circuit breakers and associated safety interlocks should have been checked mechanically during the equipment installation phase. This was, however, only preliminary and a more detailed inspection and testing procedure, both electrical and mechanical, must take place prior to putting the equipment into service. For information on complete testing and maintenance of the circuit breakers and trip units, refer to the separate circuit breaker and trip unit instruction manuals.



## 5.7 FINAL STEPS

**ENERGIZING THE SWITCHGEAR FOR THE FIRST TIME IS POTENTIALLY DANGEROUS. THEREFORE, ONLY QUALIFIED PERSONNEL SHOULD BE PRESENT WHEN THE EQUIPMENT IS ENERGIZED. IF PROBLEMS CAUSED BY DAMAGE OR POOR INSTALLATION PRACTICES HAVE NOT BEEN DETECTED IN THE CHECKOUT PROCEDURE (PREVIOUSLY DESCRIBED), DEATH, PERSONAL INJURY OR SERIOUS DAMAGE CAN RESULT WHEN POWER IS APPLIED.**

Before energizing, another thorough check should be made using the following checklist.

1. Have circuit breakers and other operation mechanisms been exercised?
2. Has electrical insulation resistance been tested phase-to-phase and phase-to-ground? Record these readings for future reference.
3. Have relay, meter and instrument connections been checked?
4. Have the electrically operated mechanisms of all circuit breakers been checked?
5. Has the ground fault protection system been checked in accordance with the National Electrical Code?
6. Are the adjustable trip units properly set?
7. Is all field wiring secured and not in contact with live bus?
8. Are all grounding connections properly made?
9. Has an inspection been performed to ensure that all debris, dirt, tools, scrap wire, and any other foreign objects were removed and that all vent openings are free from obstructions?
10. Have all barriers and covers been replaced and doors closed and latched?
11. Turn all circuit breakers to the OFF position before energizing the bus.
12. Electrically-operated breakers:  
Have all breakers in the disconnected position. Rack each breaker in one at a time after the board is energized. This way only one breaker will be electrically charged at a time. This is done so that control circuit fuses are not overloaded by all breakers charging at the same time.

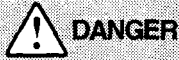
**SECTION 6: PERIODIC INSPECTION AND TESTING****6.1 GENERAL INFORMATION**

**BEFORE PROCEEDING WITH ANY INSTALLATION, TESTING, START-UP OR MAINTENANCE, REVIEW ALL OF SECTION 1 FOR SAFETY PRACTICES AND RECOMMENDATIONS. FAILURE TO DO SO COULD RESULT IN DEATH, SERIOUS BODILY INJURY OR PROPERTY DAMAGE.**



**WHEN INSPECTING, REPAIRING AND PREFORMING MAINTENANCE ON A MAGNUM DS SWITCHGEAR ASSEMBLY, THE FACT THAT DANGEROUS VOLTAGES MAY EXIST MUST BE KEPT IN MIND. PRECAUTIONS MUST BE TAKEN TO ENSURE THAT PERSONNEL DO NOT COME IN CONTACT WITH ENERGIZED PARTS. FAILURE TO DO SO COULD RESULT IN DEATH, PERSONAL INJURY OR ELECTRICAL SHOCK.**

Some common general precautions for high power circuits are:

1. All connections should be considered energized until the crew expecting to work on them is assured that the circuits are de-energized, and all precautions have been taken to ensure that there is no chance of a circuit being energized after work is underway.
2. Breakers which have been opened to de-energize a circuit to permit work on the equipment should be locked open and a suitable visible warning device placed on them.
3. Do not work on parts normally carrying high current until they have been disconnected from the system and connected to the ground bus. When performing maintenance, provisions should be made by the purchaser for connecting adequate flexible ground leads to every part of the switching equipment.
4. A good and reliable ground connection is necessary for every switchgear assembly installation. This ground connection should be of sufficient capacity to take care of any abnormal condition that might occur on the system and should be independent of the grounds used for any other apparatus.

**6.2 ACCESS TO SWITCHGEAR ASSEMBLY PARTS****6.2.1 MAIN BUS AND CABLE COMPARTMENT**

A Magnum DS Metal-Enclosed Low-Voltage Switchgear Assembly is designed so that internal compartments provide isolation between the Magnum DS circuit breaker compartment, the main bus and cable compartment. Access to high current parts is provided by removable covers and barriers.



**BARRIERS AND COVERS SHOULD NOT BE REMOVED UNLESS THE PARTS TO BE EXPOSED ARE DE-ENERGIZED. ADDITIONALLY, BE CERTAIN THAT ALL BARRIERS AND COVERS ARE PROPERLY REPLACED IMMEDIATELY UPON CONCLUSION OF MAINTENANCE OR INSPECTION PROCEDURES. FAILURE TO DO SO COULD CAUSE DEATH, BODILY INJURY OR PROPERTY DAMAGE.**

**6.2.2 DRAWOUT MAIN DISCONNECTING CONTACTS AND CURRENT TRANSFORMERS**

The primary stationary disconnecting contacts and ring-type current transformers are located on the breaker cell rear wall. These contacts and transformers are easily exposed unless provided with an optional safety shutter system.



**BE EXTREMELY CAREFUL NOT TO TOUCH ANY CONTACTS OR TRANSFORMERS UNLESS ALL UPPER AND LOWER HIGH CURRENT PARTS ARE DE-ENERGIZED. FAILURE TO DO SO COULD CAUSE DEATH, PERSONAL INJURY OR ELECTRICAL SHOCK.**

**6.2.3 CONTROL EQUIPMENT**

With the exception of apparatus such as current transformers and space heaters, control equipment is generally accessible without exposing high voltage parts.

**6.3 INSPECTION AND MAINTENANCE SCHEDULE**

To assure high quality service, a definite maintenance schedule is essential. Plant operation and local conditions vary to such an extent that the schedule should be tailored to the conditions. The following general requirements should be helpful in establishing a program.

**DANGER**

**WHEN ENERGIZED, A CIRCUIT BREAKER IS PART OF A HIGH POWER SYSTEM. BEFORE ATTEMPTING ANY INSPECTION OR MAINTENANCE, BE SURE THAT ALL PRIMARY AND CONTROL CIRCUITS HAVE BEEN DE-ENERGIZED AND GROUNDED AS REQUIRED. ALSO MAKE CERTAIN THAT PROPER STEPS HAVE BEEN TAKEN TO BE SURE THAT THEY WILL REMAIN DE-ENERGIZED UNTIL ALL WORK IS COMPLETED. FAILURE TO DO SO COULD RESULT IN DEATH, BODILY INJURY OR ELECTRICAL SHOCK.**

### 6.3.1 INDIVIDUAL DEVICES

The maintenance schedule for individual devices, such as circuit breakers, relays and instruments, should be based first on the recommendations contained in their individual instruction books. These operations should be coordinated with the overall program to result in the least operating inconvenience and circuit shutdown.

### 6.3.2 OVERALL ASSEMBLY INSTALLATION

When operating and local conditions are normal the switchgear assembly should be given a thorough overall maintenance check at least annually. Where abnormal conditions exist, more frequent inspection and maintenance is necessary.

### 6.3.3 BUSES AND CONNECTIONS

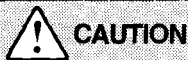
**CAUTION**

**THE MILD SOLVENTS DESCRIBED ARE FLAMMABLE. PROVIDE ADEQUATE VENTILATION AND KEEP AWAY FROM FLAMES AND OTHER IGNITION SOURCES. CONSULT YOUR SAFETY DEPARTMENT BEFORE USING.**

De-energize primary circuits and remove barriers from primary compartments. Before cleaning, record "megger" readings between phases and to ground. Inspect for signs of overheating or weakened insulation. Remove as much dirt, dust and other foreign material as possible from the insulation and conductors with minimum exposure to any solvents. The recommended cleaning procedure is to use an industrial quality vacuum cleaner and/or a lint-free cloth. In most cases, this will be sufficient. For accumulations which cannot be removed by the above procedure, a lint-free cloth slightly dampened with water can be used. Allow the switchgear apparatus to dry for at least four hours at room temperature before energizing. If this

procedure does not produce satisfactory results, use lint-free cloth dampened with a mild solvent, such as mineral spirits, Stoddard solvent, or isopropyl alcohol. Dry the same as when using a water dampened cloth.

After buses and insulation have been dusted, wiped clean, and dried, take "megger" readings again between the buses and ground and between phases. Keep a record of these readings for future reference in determining when trends occur that would indicate a decrease of resistance.

A one-minute dielectric test was preformed on all bus at the factory in accordance with ANSI C37.20.1. Repeating these tests is not required for field installation unless the equipment has been in extended or outdoor storage, or major bus modifications have been made. If required, 2200 Vac should be applied between each phase, and each phase-to-ground. All connections to the bus from control power or metering circuits must first be isolated from the bus. Circuit Breakers must be in the withdrawn or removed position. Devices such as lightening arresters and capacitors must also be disconnected.

### 6.3.4 DRAWOUT, MAIN DISCONNECTING CONTACTS AND SUPPORTS

Remove each breaker from its cell. Remember, all circuits should be de-energized. Expose primary contacts and their supports. Inspect for abnormal wear or overheating. Discoloration of the surface is not harmful unless corrosion due to atmospheric conditions is severe, leaving deposits on the surface. Follow the cleaning instructions outlined in Section 6.3.3. Check each breaker while it is out of the housing for all items recommended in the instruction book applying to the breaker.

### 6.3.5 INSTRUMENTS, RELAYS AND OTHER PANEL DEVICES

Individual devices should be maintained according to the specific instructions supplied for each device. Remove relay covers and inspect interiors for dust or dirt. All devices should be checked for correct operation.

### 6.3.6 SECONDARY WIRING, BLOCKS AND CONNECTIONS

Check all wiring connections for tightness, including those at the current and voltage transformers and at the terminal blocks where circuits leave the assembly. Make sure that all secondary wiring connections are properly connected to the switchgear assembly ground bus where so indicated. Visually inspect control circuit secondary contact blocks, both fixed in the cell and moveable on the breaker, for abnormal signs of wear, fatigue or overheating.

### 6.3.7 MECHANICAL PARTS

Visually check and manually operate mechanical moving parts, such as cell switches, position interlocks, cell protective shutters (when provided), door latches/hinges, and drawout rails.

### 6.3.8 VENTILATION

Check all air passages and intakes for obstructions and accumulations of dirt. When filters are used, replace or clean when dirty.

### 6.3.9 RECORDS

The condition of each vertical section at the time of inspection should be listed in a permanent record to become a guide for anticipating the need for replacements or for special attention between regular maintenance periods.

### 6.3.10 ABNORMAL CONDITIONS

Type Magnum DS Switchgear Assemblies have been designed for "NORMAL" operating conditions as defined in ANSI C37.20.1. Local conditions such as high humidity, salt-laden atmosphere, corrosive gases, heavy dust, or severe circuit operating conditions are considered to be abnormal. Any of these conditions will require more frequent inspections.

It should be emphasized that a series of quarterly inspections are advisable until the progressive facts of the local conditions can be analyzed to determine a schedule which will maintain equipment in satisfactory condition.

In some locations, conditions may be so bad that the frequency of maintenance will interfere with operation and production schedules. In such cases, consideration should be given to the possibility of enclosing the switchgear assembly in a relatively tight room. If this approach is followed, a sufficient quantity of clean air must be supplied to the room to ensure that a positive pressure is maintained in the room. Under such conditions, a more normal maintenance schedule can be established. Such an arrangement could also provide for cooling the air where the ambient temperature is relatively high, further improving operation conditions.

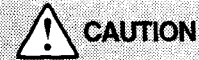

**FAILURE TO INSPECT, CLEAN, LUBRICATE AND MAINTAIN THE SWITCHGEAR ASSEMBLY AT RECOMMENDED FREQUENCIES COULD RESULT IN FAILURE OF THE EQUIPMENT TO OPERATE PROPERLY UNDER FAULT CONDITIONS, WHICH COULD CAUSE EQUIPMENT DAMAGE, DEATH AND/OR BODILY INJURY.**

### 6.3.11 LUBRICATION

A metal-enclosed low-voltage switchgear assembly is designed so that lubrication is not required under normal conditions. Abnormal local conditions, such as high humidity, salt-laden atmosphere, corrosive gases, or severe circuit operating conditions, may demand the use of lubricants. In such cases, a dry or powder lubricant may be used on moving or mating mechanical parts, and a thin film of "Vaseline" on disconnecting contacts. The application of the lubricants should be held to minimum to reduce the accumulation of dust and dirt. During routine maintenance old lubricants should be wiped off before fresh lubricants are applied.

### 6.3.12 RENEWAL PARTS

When ordering renewal or spare parts, include as much information as possible. In many cases, the style number of the new part can be obtained from identification on the old part. Always include a description of the old part. Specify the rating, vertical section and compartment number. Always supply the general order number and/or the shop order number of the assembly itself.



NOTES:

www.ElectricalPartManuals.com

FOR RENEWAL PARTS INFORMATION CALL YOUR LOCAL AUTHORIZED CUTLER-HAMMER DISTRIBUTOR. FOR THE NAME OF THE NEAREST CUTLER-HAMMER DISTRIBUTOR, PLEASE CALL:

**1-800-525-2000**

TO ASSURE SAFETY OF OPERATION AND CONTINUITY OF SERVICE, ALWAYS USE GENUINE CUTLER-HAMMER AFTERMARKET PARTS AND PRODUCT UPGRADES.

SHOULD YOU NEED FACTORY ASSISTANCE ON THIS Magnum DS LOW-VOLTAGE ASSEMBLY OR OPTIONS FOR UPGRADING YOUR OTHER LOW-VOLTAGE ASSEMBLIES PRODUCTS, CALL:

**1-800-BKR-FAST  
(1-800-257-3278)**

This instruction booklet is published solely for information purposes and should not be considered all inclusive. If further information is required, you should consult Cutler-Hammer.

Sale of product shown in this literature is subject to terms and conditions outlined in appropriate Cutler-Hammer selling policies or other contractual agreement between the parties. This literature is not intended to and does not enlarge or add to any such contract. The sole source governing the rights and remedies of any purchaser of this equipment is the contract between the purchaser and Cutler-Hammer.

**NO WARRANTIES, EXPRESSED OR IMPLIED, INCLUDING WARRANTIES OF FITNESS FOR A PARTICULAR PURPOSE OR MERCHANTABILITY, OR WARRANTIES ARISING FROM COURSE OF DEALING OR USAGE OF TRADE, ARE MADE REGARDING THE INFORMATION, RECOMMENDATIONS AND DESCRIPTIONS CONTAINED HEREIN.** In no event will Cutler-Hammer be responsible to the purchaser or user in contract, in tort (including negligence), strict liability or otherwise for any special, indirect, incidental or consequential damage or loss whatsoever, including but not limited to damage or loss of use of equipment, plant or power system, cost of capital, loss of power, additional expenses in the use of existing power facilities, or claims against the purchaser or user by its customers resulting from the use of the information, recommendations and descriptions contained herein.

Cutler-Hammer

221 Heywood Road  
Arden, NC 28704