

INSTRUCTION MANUAL

For

Cutler-Hammer DST-2VR

Vacuum Unit Replacement Of

Federal Pacific DST-2, 1200/2000A

Utilizing The VCP-WR Element

CUTLER-HAMMER ELECTRIC CORPORATION
POWER BREAKER CENTER
310 Maxwell Avenue
Greenwood, S.C. 29646
(864)223-6525

INSTRUCTION MANUAL

For

OPERATION AND MAINTENANCE

Of The

CUTLER-HAMMER DST-2VR

250 and 350 MVA, 4.76kV

500 MVA, 8.25kV

500 and 750 MVA, 15kV

Vacuum Unit Replacement Of

Federal Pacific DST-2

1200 or 2000 Amp Circuit Breakers

Utilizing The VCP-WR Element

**READ AND UNDERSTAND THESE INSTRUCTIONS BEFORE ATTEMPTING ANY
INSTALLATION, OPERATION OR MAINTENANCE OF THIS CIRCUIT BREAKER.**

WARNING

THE CIRCUIT BREAKER AND VACUUM CONVERTED COMPONENTS DESCRIBED IN THIS BOOK ARE DESIGNED AND TESTED TO OPERATE WITHIN THE ELECTRICAL RATINGS WHICH APPEAR ON THE NAMEPLATE OF EACH MANUFACTURED UNIT. OPERATION OUTSIDE OF THESE RATINGS MIGHT CAUSE THE EQUIPMENT TO FAIL, RESULTING IN DEATH, PERSONAL INJURY, AND/OR PROPERTY DAMAGE.

IT IS THE RESPONSIBILITY OF THE EQUIPMENT USER TO ENSURE THAT THE EQUIPMENT IS APPLIED ACCORDING TO APPLICABLE SAFETY CODES, SAFETY STANDARDS, AND REGULATIONS.

www.ElectricalPartMan.com

TABLE OF CONTENTS

LIST OF ILLUSTRATIONS	1
SECTION 1 - INTRODUCTION	3
SECTION 2 - SAFE PRACTICES	4
SECTION 3 - SPECIAL TOOLS	6
SECTION 4 - INSTALLATION INSPECTION	7
4.1 EXAMINATION FOR DAMAGE	7
4.2 OPERATIONAL POSITIONS	7
4.3 INSERTION PROCEDURE	8
4.4 REMOVAL PROCEDURE	12
4.5 MANUAL OPERATIONAL CHECKS	13
4.6 VACUUM INTEGRITY CHECKS	13
4.7 APPLIED POTENTIAL TEST	13
4.8 CONTACT EROSION, CONTACT WIPE AND STROKE	14
4.9 PRIMARY CIRCUIT RESISTANCE TESTS	14
4.10 ELECTRICAL OPERATIONAL CHECKS	14
4.11 MECHANICAL INTERLOCK (FLOOR TRIP) OPERATIONAL CHECKS	14
SECTION 5 - DESCRIPTION AND OPERATION	15
5.1 VACUUM INTERRUPTER	15
5.1.1 THE INTERRUPTER ASSEMBLY	15
5.1.2 CONTACT EROSION INDICATOR	17
5.1.3 CONTACT WIPE AND STROKE	17
5.2 PHASE BARRIERS	18
5.3 PRIMARY BUSHINGS AND DISCONNECTS	18
5.4 STORED ENERGY MECHANISM	18
5.4.1 CLOSING SPRING CHARGING	23
5.4.2 CLOSING OPERATION	23
5.4.3 TRIPPING OPERATION	24
5.4.4 TRIP-FREE OPERATION	24
5.5 ELECTRICAL CONTROL	24
5.6 SECONDARY CONNECTION BLOCK	28

5.7	INTERLOCKS	28
5.7.1	ANTI-CLOSE INTERLOCK	28
5.7.2	LEVERING INTERLOCK (FLOOR TRIP/INTERLOCK PEDAL)	29
5.7.3	SHUTTER INTERLOCK	29
5.8	LEVERING SYSTEM TRIP AND SPRING RELEASE INTERLOCKS .	29
5.9	LEVERING SYSTEM & LEVERING HANDLE	29
5.10	GROUNDING CONTACT	32
SECTION 6 - MAINTENANCE AND INSPECTION		34
6.1	SAFE WORK CONSIDERATIONS	34
6.2	FREQUENCY OF INSPECTION	34
6.3	VACUUM INTERRUPTER INTEGRITY TEST	35
6.4	CONTACT EROSION CHECKS	38
6.5	CLEANING	38
6.6	SECONDARY WIRING INSPECTIONS	38
6.7	INSULATION INTEGRITY TESTS	39
6.7.1	PRIMARY CIRCUIT INSULATION TESTS	39
6.7.2	SECONDARY CIRCUIT INSULATION TEST	39
6.8	PRIMARY CIRCUIT RESISTANCE TEST	40
6.9	MECHANISM INSPECTIONS	40
6.10	LUBRICATION	40
6.11	PRIMARY BUSHING AND DISCONNECT (FINGER CLUSTER) INSPECTION	41
6.12	SECONDARY CONTACT BLOCK INSPECTION	41
6.13	TROUBLESHOOTING GUIDE	44
6.14	INSPECTION AND MAINTENANCE	47
SECTION 7 - RENEWAL PARTS		49
7.1	RENEWAL PARTS ORDERING INFORMATION	49
7.2	RECOMMENDED SPARE PARTS	49
ENGINEERING SERVICE OFFICES		54

LIST OF ILLUSTRATIONS

FIGURE 1.1		
	Outline and Component Identification	2
FIGURE 4.1		
	Levering Handle	11
FIGURE 5.1		
	Contact Erosion Indication (Breaker Closed)	16
FIGURE 5.2		
	Mechanism Component Location (Front Cover Removed)	20
FIGURE 5.3		
	Closing Cam and Trip Linkage (Left Side Views)	21
FIGURE 5.4		
	Charging Spring Schematic (Left Side Views)	22
FIGURE 5.5		
	Basic Wiring Diagram	25
FIGURE 5.6		
	DC Control Schematic	26
FIGURE 5.7		
	Levering System for Breaker in Cell	33
FIGURE 6.1		
	Contact Wipe Determination	37
FIGURE 6.2		
	Relubrication Guide (Grease)	42
FIGURE 6.3		
	Relubrication Guide (Oil)	43
FIGURE 6.4		
	Torque Specification Chart	48

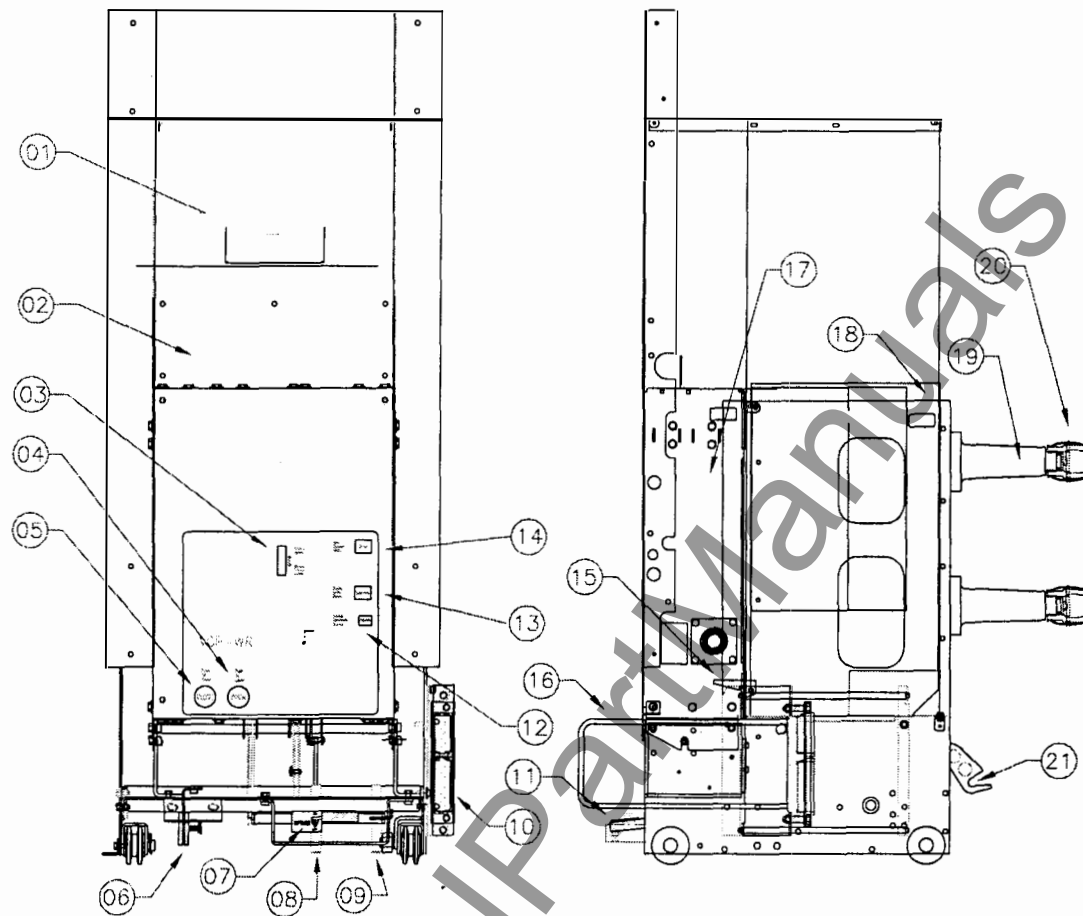

- | | |
|--------------------------------|----------------------------|
| 1. NAMEPLATE | 11. INTERLOCK PEDAL |
| 2. WIRING ACCESS | 12. OPERATIONS COUNTER |
| 3. MANUAL CHARGE | 13. CLOSING SPRING STATUS |
| 4. MANUAL OPEN | 14. MAIN CONTACT STATUS |
| 5. MANUAL CLOSE | 15. SECONDARY SLIDE LATCH |
| 6. GROUND CONTACT | 16. SECONDARY SLIDE HANDLE |
| 7. MOTOR CUTOFF SW. | 17. VCP-18WR ELEMENT |
| 8. TRIP-FREE PLUNGER | 18. PHASE BARRIER |
| 9. SPRING DISCH PLUNGER | 19. PRIMARY BUSHING |
| 10. SECONDARY CONTACT BLOCK(S) | 20. PRIMARY DISCONNECT |
| | 21. MOC OPERATOR |

◆ (NOTE: 8.25kV/15kV SHOWN, 4.76kV-250 SIMILAR)

FIGURE 1.1 OUTLINE AND COMPONENT IDENTIFICATION

SECTION 1 - INTRODUCTION

The purpose of this book is to provide information for the installation, operation, and maintenance of CUTLER-HAMMER vacuum replacement type DST-2VR circuit breakers with the VCP-WR element. The VCP-WR vacuum replacement type DST-2VR circuit breakers are designed to be used in existing type DST-2 metal-enclosed switchgear and provide equal or superior electrical and mechanical performance as compared to the design ratings of the original circuit breaker.

This book is intended to be used in conjunction with the technical information provided with the original equipment order which includes, but which is not limited to electrical control schematic and wiring diagrams, outline diagrams, installation plans, and procedures for installation and maintenance of accessory items.

Satisfactory performance is dependent upon proper application, correct installation, and adequate maintenance. It is strongly recommended that this instruction book be carefully read and followed in order to realize optimum performance and long useful life of the circuit breaker. It is further recommended that the installation be performed by a CUTLER-HAMMER trained engineer or technician.

WARNING

VACUUM REPLACEMENT TYPE DST-2VR BREAKERS ARE PROTECTIVE DEVICES AND MAXIMUM RATED DEVICES. THEREFORE, THEY SHOULD NOT UNDER ANY CIRCUMSTANCES BE APPLIED OUTSIDE OF THEIR NAMEPLATE RATING.

ALL POSSIBLE CONTINGENCIES WHICH MIGHT ARISE DURING INSTALLATION, OPERATION, OR MAINTENANCE, AND ALL DETAILS AND VARIATIONS OF THIS EQUIPMENT ARE NOT COVERED BY THESE INSTRUCTIONS. IF FURTHER INFORMATION IS DESIRED BY THE PURCHASER REGARDING A PARTICULAR INSTALLATION, OPERATION, OR MAINTENANCE OF THIS EQUIPMENT, THE LOCAL CUTLER-HAMMER ELECTRIC CORPORATION ENGINEERING SERVICES DIVISION REPRESENTATIVE SHOULD BE CONTACTED.

PLEASE REFER TO FIGURE 1.1 - OUTLINE AND COMPONENT IDENTIFICATION. IT IS IMPORTANT THAT OPERATING AND MAINTENANCE PERSONNEL BE THOROUGHLY FAMILIAR WITH THE BREAKER COMPONENTS.

SECTION 2 - SAFE PRACTICES

CUTLER-HAMMER type VCP-WR replacement breakers are equipped with high speed, high energy operating mechanisms. They are designed with several built-in interlocks and safety features to provide safe and proper operating sequences.

WARNING

TO ENSURE THE SAFETY OF PERSONNEL ASSOCIATED WITH THE INSTALLATION, OPERATION, AND MAINTENANCE OF THESE BREAKERS, THE FOLLOWING PRACTICES MUST BE FOLLOWED:

- * Only qualified persons, as defined in The National Electric Code (ANSI/NFPA 70), who are familiar with the installation and maintenance of medium voltage circuits and equipment should be permitted to work on these breakers.
- * Read and understand this instruction book before installing, operating or maintaining the vacuum replacement circuit breakers.
- * The electrical functions of the circuit breaker control circuit should not be modified or bypassed.
- * The breaker Interlock Pedal and floor trips that are operated by the cell floor ramps when levered in create the same protective interlock functions as the original DST-2 Breaker interlocks and should not be modified or bypassed.
- * Always remove the maintenance tool from the breaker after charging the closing springs.
- * Be sure the breaker is disconnected from all sources of electrical energy before working on the breaker. Always remove the breaker from the cubicle before performing any maintenance. Failure to do so could result in electrical shock, leading to death, severe personal injury, or property damage.
- * Maintenance and repairs should be performed by experienced personnel who are familiar with the components and operation of CUTLER-HAMMER type VCP-WR vacuum replacement breakers.
- * DO NOT work on a closed breaker, or a breaker with closing springs charged. Check that the closing springs are discharged before working on the breaker. (Look at the "Closing Spring Status" indicator, Figure 1.1) Failure to do so could result

in cutting or crushing injuries.

- * Check that the opening spring is discharged before working on the breaker. The opening spring is discharged when the main contacts are open. (Look at the "Main Contact Status" indicator, Figure 1.1)
- * Whenever the breaker is moved in its cell, be sure to positively identify that the breaker is left in one of its four basic cell positions which are: connect, test, disconnect, or withdrawn. (See Section 4.2) Do not leave the breaker in an intermediate position. Failure to do so could result in a flashover and possible death, personal injury, or property damage.
- * Do not use the circuit breaker as the sole means of isolating a high voltage circuit. Always remove the breaker to the "disconnect" position and follow all lockout and tagging rules of The National Electrical Code, and all applicable codes, regulations and work rules.
- * The manual spring charging handle should be used for maintenance testing only. It can be used in an emergency for charging the closing spring in cases where there is no closing voltage or where only tripping voltage is available, but in both cases, the handle must be removed immediately after manually charging the closing springs.

WARNING

FAILURE TO REMOVE SPRING CHARGING HANDLE MAY CAUSE SEVERE INJURY AND/OR EQUIPMENT DAMAGE WHEN THE BREAKER IS CLOSED.

- * Close and latch the cell door before performing any switching operations with the breaker while the breaker is in the "connect" position.
- * Close and latch the door if the cell is to be left unattended, and tag according to status.

WARNING

FAILURE TO FOLLOW THESE SAFE PRACTICES MAY RESULT IN DEATH, PERSONAL INJURY OR PROPERTY DAMAGE.

SECTION 3 - SPECIAL TOOLS

Maintenance handle: This tool is used to manually charge the closing spring. One maintenance handle is provided with each vacuum replacement breaker.

Levering Handle: The levering handle is used to lever the circuit breaker into and out of the cell. This handle is the same as the one provided with the original DST-2 breaker levering mechanism and is therefore not normally provided as part of the vacuum conversion.

Secondary connection block extension cable: The extension cable can be used to connect the circuit breaker to a "test cabinet" or to the switchgear cell's secondary receptacle block so that the breaker can be electrically operated while not installed in the switchgear cell. This extension cable is the same one provided with the original DST-2 breaker and is therefore not normally included as part of the vacuum conversion.

SECTION 4 - INSTALLATION INSPECTION

WARNING

BEFORE PLACING THE BREAKER IN SERVICE, CAREFULLY FOLLOW THE INSTALLATION PROCEDURE BELOW AND THE SAFE PRACTICES SET FORTH IN SECTION 2. NOT FOLLOWING THE PROCEDURE MAY RESULT IN INCORRECT BREAKER OPERATION LEADING TO DEATH, BODILY INJURY, AND PROPERTY DAMAGE.

When the breaker is first commissioned into service and each time the breaker is returned to service, it should be carefully examined and checked to make sure it is operating correctly.

4.1 EXAMINATION FOR DAMAGE

Examine the breaker for loose or obviously damaged parts. **Never attempt to install nor operate a damaged breaker.**

4.2 OPERATIONAL POSITIONS

The breaker has four basic operational positions:

- (1) **Breaker withdrawn from cell.** In the "withdrawn" position the breaker is out of the cell. The levering handle is not required for this position. The breaker can be operated in this position and extreme care should be exercised to avoid inadvertent operation and possible injury or equipment damage.
- (2) **Breaker in the cell in the disconnect position.** As the breaker is pushed into the cell it will reach a position where all four wheels are on the cell floor guide rails and the floor spring discharge interlock has not activated. This is the "disconnect" position and the breaker can still be operated because there is no interface of the cell floor interlocks with breaker interlock linkage. No cell labeling is provided to verify this position.
- (3) **Breaker in the test position.** The "test" position is achieved when the breaker has advanced into the cell about 8 inches from the disconnect position and the audible click of the lock engaging the interlock rail has been observed. The test position can be verified by the inability to move the breaker in or out, the Interlock Pedal is in the up position, and the cell label "test" is visible on the floor of the cell in front of the breaker's left front wheel.

- (4) **Breaker in the connect position.** The "connect" position is achieved by moving the breaker into the cell using the levering handle for about 8 inches of travel (from the test position) until a mechanical stop is reached. As the breaker is advanced from the test position, the primary voltage source shutters will open allowing the breaker stabs to engage with the source. This is the fully engaged or connected position. The connect position can be verified by the inability to move the breaker in or out, and the cell label "operating" is visible on the floor of the cell in front of the breaker's left front wheel. The breaker is now ready for service.

CAUTION

DO NOT USE ANY TOOL TO LEVER THE BREAKER FROM TEST OR CONNECTED POSITION OTHER THAN THE LEVERING HANDLE. (Figure 4.1)

4.3 INSERTION PROCEDURE

- a. Place the breaker in the withdrawn position. In the "withdrawn" position the breaker is out of the cell. The levering handle is not required for this position. The breaker can be operated in this position and extreme care should be exercised to avoid inadvertent operation and possible injury or equipment damage.

CAUTION

THE BREAKER CAN BE OPERATED IN THE WITHDRAWN POSITION AND EXTREME CARE SHOULD BE EXERCISED TO AVOID INADVERTENT OPERATION AND POSSIBLE INJURY OR EQUIPMENT DAMAGE.

- b. From the withdrawn position, align the center groove of the breaker wheels with the guide rails of the cell.
- c. Check that the closing spring status indicator reads "DISCHARGED" and that the main contact status indicator reads "OPEN". Manually trip, close, and trip the breaker as needed to obtain this status.
- d. Push the circuit breaker into the cell until all the wheels are on the guide rails and the spring discharge linkage has not cycled. No mechanical stop will be reached. This is the "disconnect" position and the breaker can still be operated because

there is no interface of the cell floor interlocks with breaker interlock linkage. No cell labeling is provided to verify this position.

- e. Push or lever the breaker further into the cell. Depressing the Interlock Pedal will make this operation easier but, due to the cell design, depressing the pedal is not required at this stage.

Note: Depressing of the Interlock Pedal automatically positions the motor cutoff switch to "off".

- f. Once movement has started, the Interlock Pedal should be released if depressed. The levering handle may be required to move the breaker completely into the test position and its use is illustrated in Figure 4.1. An audible click of the interlock plunger engaging the interlock rail will be observed at about 8 inches travel from the disconnect position. The Interlock Pedal will travel down at the beginning of movement and rapidly rise to lock the breaker in the test position at the end of the normal travel from disconnect to test. The movement of the handle provides an open signal that remains throughout all intermediate breaker positions and the floor trip will be combined with a closing signal between the disconnect and test position to discharge the closing springs. The breaker remains in the trip free-state until the test position is reached. The test position can be verified by the inability to move the breaker in or out, the Interlock Pedal is in the up position, and the cell label "test" is visible on the floor of the cell in front of the breaker's left front wheel.
- g. In the "test" position, the breaker can be operated manually and electrically, thus allowing maintenance tests or checks. To operate the breaker electrically, the secondary control block must be engaged at this time. The slider is located on the lower right hand area of the circuit breaker frame. If electrical testing is desired at this stage, engage the secondary control block slider by releasing the slide latch and pushing the slider toward the rear several inches. Push firmly on the front side of the slider until the contact block engages with the corresponding cell receptacle. Return the manual motor cutoff switch to the "on" position. The spring charging motor will begin to run and charge the closing spring. The breaker is now in the "test" position, with control voltage applied, and ready for electrical or manual testing.
- h. To install the breaker in the connected position the levering handle will have to be used. Insure the breaker is open and engage the levering handle with the breaker and floor levering cutouts (See Figure 4.1).

- i. Depress the Interlock Pedal and start levering in the breaker by shifting the levering handle back and forth. Once movement has started, the pedal should be released. The closing springs may be in the charged state but the internal PS switch will open circuit the close spring release coil (preventing an electrical close). At this point any attempt to mechanically close the breaker will cause a trip-free operation with no re-charging of the closing springs (PS2 has open-circuited the charging motor circuit and the Interlock Pedal operation has automatically turned the motor cutoff switch to "off"). As advancement into the cell continues, the primary voltage source shutters will open allowing the breaker stabs to engage with the source.

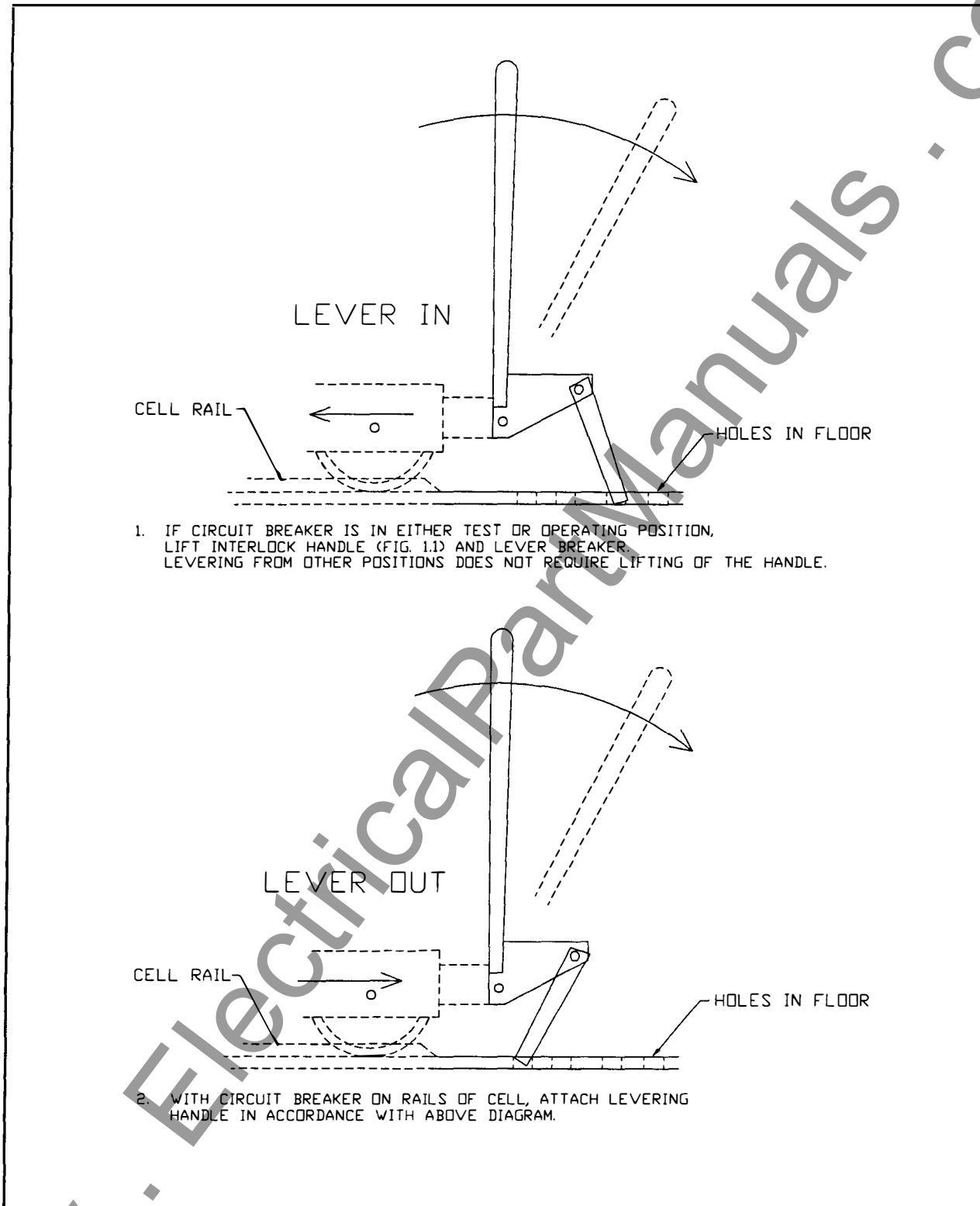

FIGURE 4.1 LEVERING HANDLE

- j. Continue moving the breaker into the cell using the levering handle for about 8 inches of travel from the test position until a mechanical stop is reached. This is the fully engaged or connected position. The connect position can be verified by the inability to move the breaker in or out, the Interlock Pedal is up and has released the trip mechanism, and the cell label "operating" is visible on the floor of the cell in front of the breaker's left front wheel. Manually return the motor cutoff switch to the "on" position. The breaker is now ready for service.

4.4 REMOVAL PROCEDURE

To remove the breaker from the cell it must be in the open position. Insure the breaker is open and engage the levering handle. The Interlock Pedal must be depressed which will raise the trip mechanism and trip the breaker. Move the breaker out using the levering handle illustrated in figure 4.1. The breaker will start coming out of the cell before the main stabs are disconnected and will be in a non-operable mode and will go through a trip free operation if any attempt to close it is made in the intermediate position. Also, the secondary control block will disengage automatically before the main stabs are disconnected. The shutters will close after the main stabs have cleared, isolating the breaker from its source. Continue levering out until the position indicator on the floor of the cell shows test and the Interlock Pedal rises to lock the breaker in position. At this time you are in the test position and the trip mechanism is released, allowing the breaker to be operated either electrically or mechanically. If you desire to electrically open or close the breaker in the test position, the secondary control block must be re-engaged and the manual motor cutoff switch turned "on".

To remove the breaker from the test position to the disconnected position, the breaker must be tripped if closed, the Interlock Pedal must be depressed, and the secondary contact block should be disengaged. When moving out of the test position, a floor close signal will combine with the trip signal from the Interlock Pedal to force a trip-free condition. This will cause the charging springs to discharge leaving the breaker in the open position and the closing springs discharged. The breaker is in a non-operable state.

Once the breaker is withdrawn past the floor trip activation area, it is in the disconnected position. The levering handle should be removed at this point. The breaker is ready to be removed from the cell if desired.

4.5 MANUAL OPERATIONAL CHECKS

Perform manual operational checks. To make these checks, the breaker must be in either the withdrawn, disconnect, or test position . With the breaker in one of the above positions, place the maintenance handle into the manual charging opening and charge the closing spring. Approximately 36 up and down strokes of the handle are required to cause the "Charging Spring Status" indicator to show "Charged."

Remove the maintenance handle.

CAUTION

ALWAYS REMOVE THE MAINTENANCE HANDLE AFTER CHARGING THE SPRING. FAILURE TO REMOVE THE MAINTENANCE HANDLE FROM THE BREAKER COULD CAUSE DAMAGE TO THE BREAKER MECHANISM, AND CAN BE HAZARDOUS TO PERSONNEL IF THE BREAKER WERE TO CLOSE.

Close and open the breaker by pushing the manual close button then the manual open button located on the front of the breaker. (See Figure 1.1)

Repeat the charge, close, and open procedure several times to confirm that the mechanism operates consistently and reliably.

CAUTION

DO NOT ATTEMPT TO INSTALL OR OPERATE A VACUUM CIRCUIT BREAKER UNTIL A VACUUM INTEGRITY TEST IS PERFORMED.

Remove the breaker from the cell and move to an area with adequate room for the following tests:

4.6 VACUUM INTEGRITY CHECKS

Check the vacuum integrity of the interrupters of three pole units by conducting the applied potential test described in Section 6.3 of this book.

4.7 APPLIED POTENTIAL TEST

Perform insulation integrity tests as described in Section 6.7.

4.8 CONTACT EROSION, CONTACT WIPE AND STROKE

Close the breaker. Check all three vacuum interrupter erosion indicator marks as described in Section 6.4 and shown in Fig. 5.1 to verify that contact erosion is not greater than the service limit. Check contact wipe and stroke (Section 5.1.3).

4.9 PRIMARY CIRCUIT RESISTANCE TESTS

Check the primary circuit resistance of the three pole units as described in Section 6.8. The resistance should not exceed the values specified. Record the values for future reference.

4.10 ELECTRICAL OPERATIONAL CHECKS

Perform electrical operations checks. Close and trip the circuit breaker electrically several times to verify that the operation is reliable and consistent. Check that the operation of the spring charging motor is reasonably prompt and that the motor makes no unusual noise. These checks can be performed by placing the breaker into its "test" position in the switchgear cell (section 4.2), or by connecting the breaker to a "test cabinet" or the switchgear cell's secondary receptacle using the special extension cable designed for this purpose and described in section 3.

WARNING

WHILE CHECKS ARE PERFORMED IN THE BREAKER COMPARTMENT, CARE MUST BE EXERCISED TO MAKE CERTAIN THAT PRIMARY CIRCUIT IS NOT ENERGIZED.

DO NOT PERFORM ELECTRICAL OPERATION CHECKS WITH THE BREAKER IN THE "CONNECT" POSITION BECAUSE OF THE POSSIBILITY OF CONNECTING DE-ENERGIZED LOAD CIRCUITS TO THE ELECTRICAL POWER SOURCE, RESULTING IN DEATH, PERSONAL INJURY OR EQUIPMENT DAMAGE.

4.11 MECHANICAL INTERLOCK (FLOOR TRIP) OPERATIONAL CHECKS

Check the operation of the mechanical interlock (floor trip) by observing the main contact status and closing spring status as the breaker is moved between the disconnect and test position. The breaker should discharge its closing springs when moved between the disconnect and test positions and remain open between the test and connect positions. (Refer to Section 5.7 for information concerning correct operation of these components).

SECTION 5 - DESCRIPTION AND OPERATION

CUTLER-HAMMER type DST-2VR replacement breakers with VCP-WR elements are horizontal, draw-out, vacuum circuit breakers. They are designed to be used with existing installations of type DST-2 metal-clad switchgear. The front mounted spring type stored energy mechanism facilitates inspection and provides improved access to components for servicing. The long life characteristics of the vacuum interrupters and proven high reliability of spring-type stored energy mechanisms assure long, trouble-free service with minimum maintenance.

5.1 VACUUM INTERRUPTER

Vacuum interrupters offer the advantages of enclosed arc interruption, small size and weight, longer life, reduced maintenance, minimal mechanical shock, and elimination of contact degradation caused by environmental contamination.

In the closed position, current flows through the interrupter moving and fixed stems and the faces of the main contacts. As the contacts part, an arc is drawn between the contact surfaces. The arc is rapidly moved away from the main contacts to the slotted contact surfaces by self-induced magnetic effects. This minimizes contact erosion and hot spots on the contact surfaces. The arc flows in an ionized metal vapor and as the vapor leaves the contact area, it condenses into the metal shield which surrounds the contacts.

At current zero, the arc extinguishes and vapor production ceases. Very rapid dispersion, cooling, recombination, and deionization of the metal vapor plasma and fast condensation of metal vapor causes the vacuum to be quickly restored and prevents the transient recovery voltage from causing a restrike across the gap of the open contacts.

5.1.1 THE INTERRUPTER ASSEMBLY

Each interrupter is assembled at the factory as a unit to assure correct dimensional relationships between working components. The interrupter assembly consists of a vacuum interrupter, glass polyester insulation, upper and lower clamps, buss connections, bell crank, operating rod, and contact load spring. The vacuum interrupter is mounted vertically with the fixed stem upward and the moving stem downward. The glass polyester insulation and clamps support the interrupter and are fastened to the breaker's stored energy mechanism frame. Upper and lower buss work provide electrical connections from each interrupter to the breaker's cast epoxy primary bushings while flexible shunts provide isolation from mechanical shock and movement of the interrupter's moving stem. The operating rod, loading spring, and bell crank transfer mechanical motion from the breaker's operating mechanism to the moving stem of the interrupter. A vacuum interrupter erosion indicator is located on the moving stem of the interrupter. It is visible when the breaker is withdrawn and is viewed from the rear of the breaker. (See Figure 5.1)

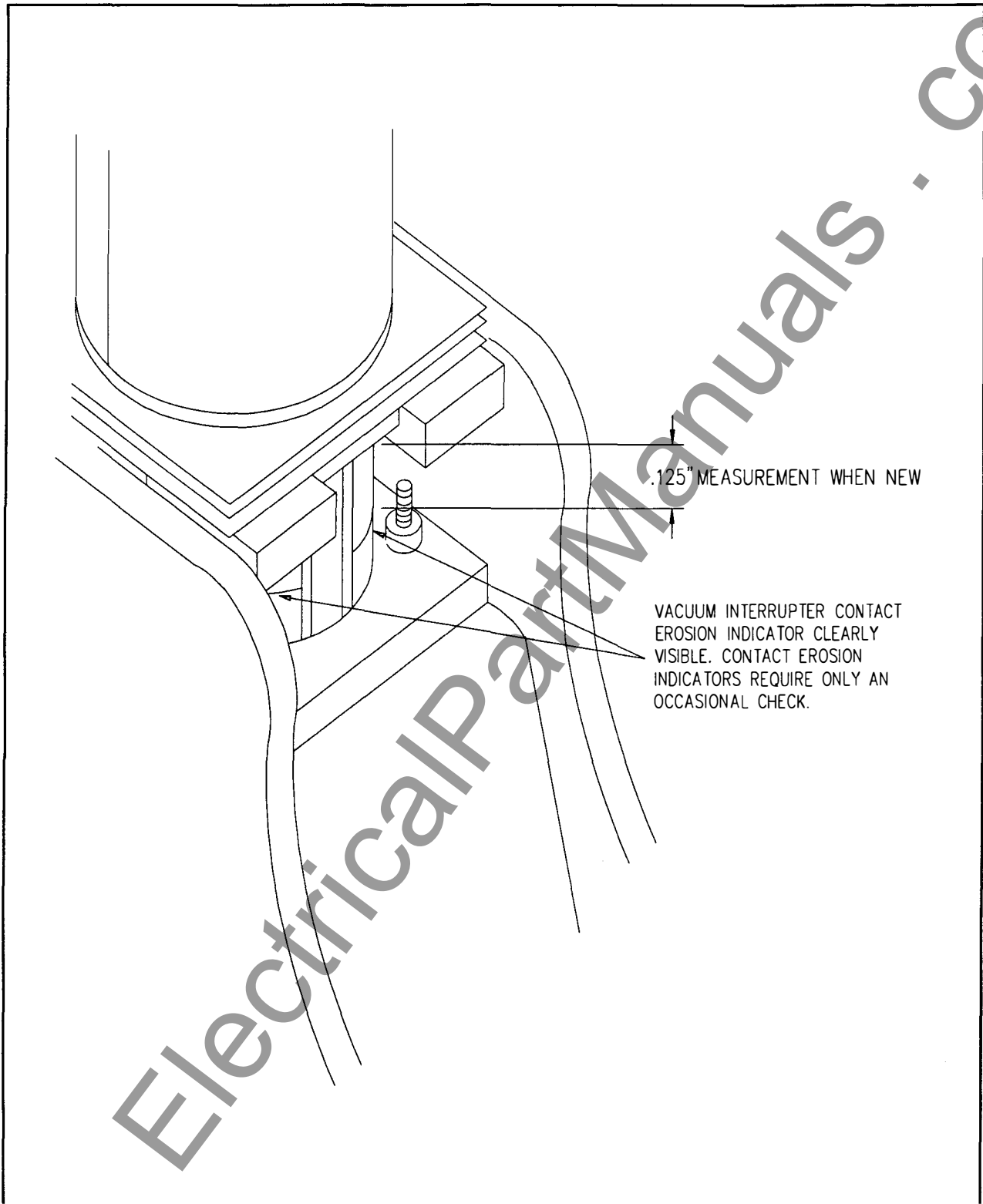

FIGURE 5.1 CONTACT EROSION INDICATION (BREAKER CLOSED)

5.1.2 CONTACT EROSION INDICATOR

When contact erosion reaches 1/8 inch, the interrupter assembly must be replaced. The contact erosion indicator is a horizontal line marked on the moving stem of the interrupter (See Figure 5.1).

To judge erosion, close the breaker and view the erosion mark on each vacuum interrupter moving stem. When the vacuum interrupter is new, the mark is approximately 1/8 inch below the stem guide. If the mark is no longer visible (because it has moved under the stem guide), the interrupter is at the end of its allowable wear, and the complete interrupter assembly must be replaced.

WARNING

FAILURE TO REPLACE THE INTERRUPTER ASSEMBLY WHEN INDICATED BY THE CONTACT EROSION INDICATOR COULD CAUSE THE BREAKER TO FAIL, LEADING TO DEATH, PERSONAL INJURY OR PROPERTY DAMAGE.

5.1.3 CONTACT WIPE AND STROKE

Wipe is a measure of (1) force to hold vacuum interrupter contacts closed and (2) energy to hammer the contacts open with sufficient speed for safe and clean interruption.

Stroke is the gap between fixed and moving contacts of vacuum interrupter with the breaker open.

The circuit breaker mechanism provides a fixed amount of motion to the operating rods. First portion of the motion is used to close the contacts (i.e., stroke) and the remainder is used to further compress the preloaded wipe spring. This additional compression is called wipe. Wipe and stroke are thus related to each other. As the stroke increases due to erosion of contacts, the wipe decreases. A great deal of effort and ingenuity has been spent in the design of Type VCP-WR breakers, in order to eliminate any need for field adjustment of wipe or stroke. Thus, there is no provision for adjustments.

WARNING

THERE IS NO PROVISION FOR IN-SERVICE ADJUSTMENTS OF CONTACT WIPE AND STROKE. ALL SUCH ADJUSTMENTS ARE FACTORY SET AND SHOULD NOT BE ATTEMPTED IN THE FIELD.

5.2 PHASE BARRIERS

Phase barriers are flat sheets of insulation placed between the interrupter assemblies and at the side of the breaker frame. (See Figure 1.1) Barriers are attached to the breaker frame through angle brackets.

WARNING

ALL FOUR PHASE BARRIERS MUST BE IN PLACE BEFORE PLACING THE CIRCUIT BREAKER INTO SERVICE. FAILURE TO HAVE THEM IN POSITION CAN CAUSE DEATH, SERIOUS PERSONAL INJURY AND/OR PROPERTY DAMAGE.

5.3 PRIMARY BUSHINGS AND DISCONNECTS

The six line and load bushings, which are the primary circuit terminals of the circuit breaker, consist of six silver plated conductors cast into cyclo-aliphatic epoxy forms and are bolted to an insulated backboard. Multiple finger type primary disconnecting contacts at the ends of the conductors provide means for connecting and disconnecting the breaker to the bus terminals in the switchgear compartment.

5.4 STORED ENERGY MECHANISM

The spring-type stored energy operating mechanism is mounted above the breaker frame and in the front of the breaker. Manual closing and opening controls are at the front panel (Figure 5.2) so that they are accessible while the breaker is in any of its four basic positions. (See Section 4.2)

The mechanism stores the closing energy by charging the closing springs. When released, the stored energy closes the breaker, charges the wipe and resets springs. The mechanism may rest in any one of the four positions shown in Figure 5.3 as follows:

- a. Breaker open, closing springs discharged.
- b. Breaker open, closing springs charged.
- c. Breaker closed, closing springs discharged.
- d. Breaker closed, closing springs charged.

The mechanism is a mechanically "trip-free" type. This means that if an electrical or mechanical trip signal is present at the same time as a close signal, the closing spring will discharge without causing a closing direction movement in the primary circuit contacts.

In normal operation the closing spring is charged by the spring charging motor, and the breaker is closed electrically by the switchgear control circuit signal to energize the spring release coil. Tripping is caused by energizing the trip coil through the control circuit.

For maintenance inspection purposes the closing springs can be charged manually by using the maintenance tool and the breaker can be closed and tripped by pushing the "Push to Close" and "Push to Open" buttons on the front panel.

WARNING

KEEP HANDS AND FINGERS AWAY FROM BREAKER'S INTERNAL PARTS WHILE THE BREAKER CONTACTS ARE CLOSED OR THE CLOSING SPRINGS ARE CHARGED. THE BREAKER CONTACTS MAY OPEN OR THE CLOSING SPRINGS DISCHARGE CAUSING CRUSHING INJURY. DISCHARGE THE SPRINGS AND OPEN THE BREAKER BEFORE PERFORMING ANY MAINTENANCE, INSPECTION OR REPAIR ON THE BREAKER.

THE DESIGN OF THIS CIRCUIT BREAKER ALLOWS MECHANICAL CLOSING AND TRIPPING OF THE BREAKER WHILE IT IS IN THE "CONNECT" POSITION. HOWEVER, THE BREAKER SHOULD BE CLOSED MECHANICALLY ONLY IF THERE IS POSITIVE VERIFICATION THAT LOAD SIDE CONDITIONS PERMIT. IT IS RECOMMENDED THAT CLOSING THE BREAKER IN THE "CONNECT" POSITION ALWAYS BE DONE WITH THE CUBICLE DOOR CLOSED. FAILURE TO FOLLOW THESE DIRECTIONS MAY CAUSE DEATH, PERSONAL INJURY, OR PROPERTY DAMAGE.

ELECTRICAL TRIPPING CAN BE VERIFIED WHEN THE BREAKER IS IN THE "TEST" POSITION.

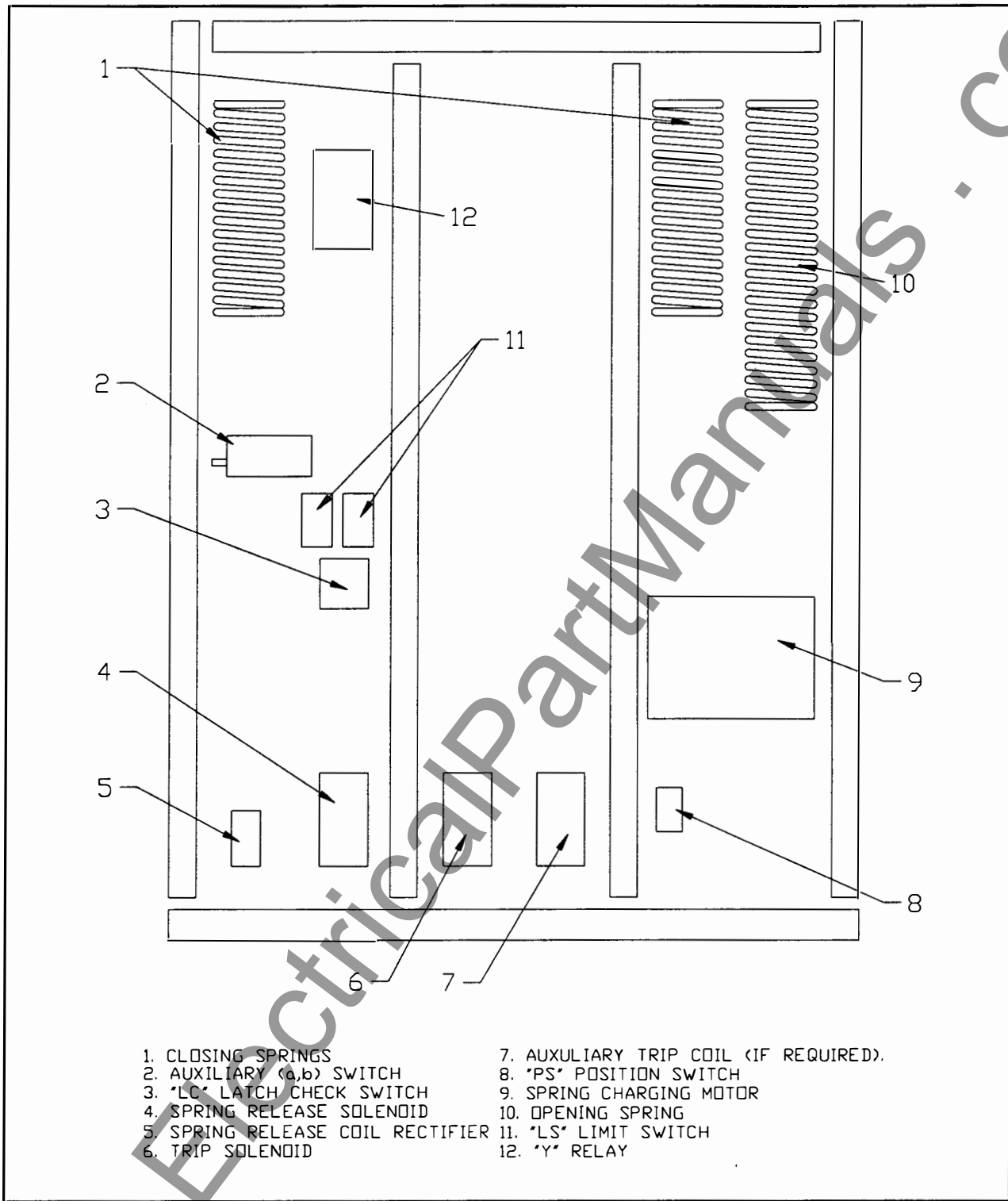

FIGURE 5.2 MECHANISM COMPONENT LOCATION (FRONT COVER REMOVED)

- 1.POLE SHAFT
- 2.MAIN LINK
- 3.BANANA LINK
- 4.TRIP LATCH
- 5.SHUNT TRIP CLAPPER
- 6.SHUNT TRIP COIL

- 7.CAM SHAFT
- 8.CLOSING CAM
- 9.OPERATING ROD
- 10.MAIN LINK ROLLER
- 11.TRIP BAR "D" SHAFT

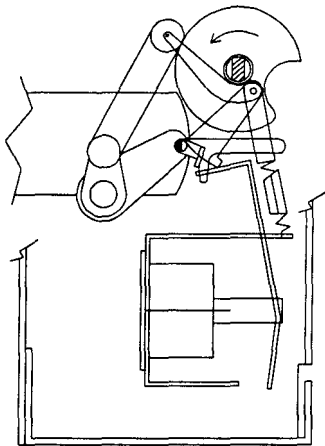

FIG. 5.3A BREAKER OPEN & CLOSING SPRING NOT CHARGED

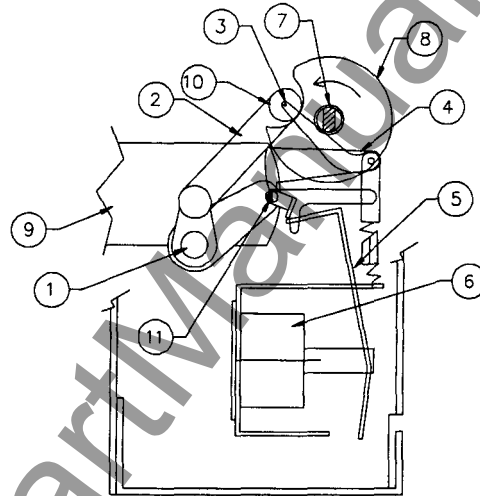

FIG. 5.3B BREAKER OPEN & CLOSING SPRING CHARGED

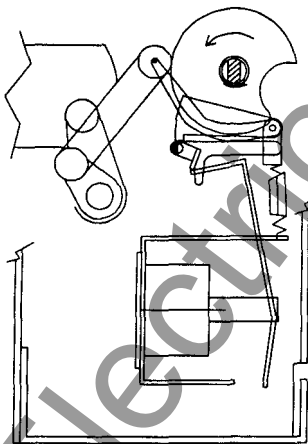

FIG. 5.3C BREAKER CLOSED & CLOSING SPRING NOT CHARGED
FIGURE 5.3 CLOSING CAM AND TRIP LINKAGE

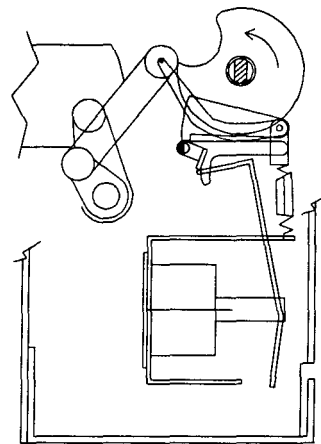
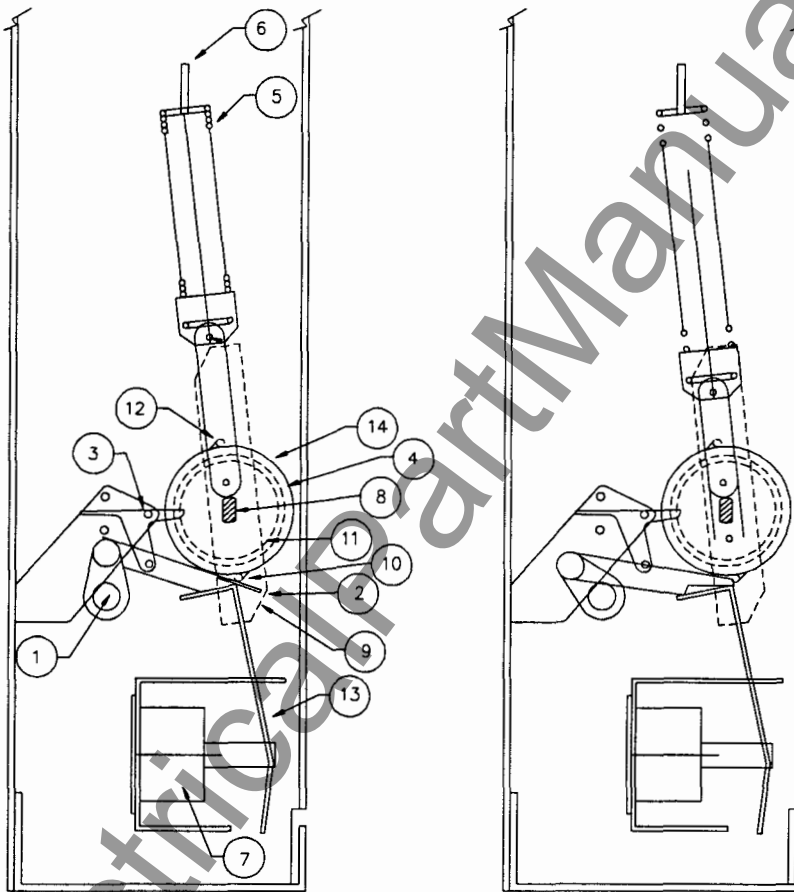

FIG. 5.3D BREAKER CLOSED AND CLOSING SPRING CHARGED

FIGURE 5.3 CLOSING CAM AND TRIP LINKAGE (LEFT SIDE VIEWS)

- | | |
|---------------------------------|------------------------------------|
| 1. POLE SHAFT | 8. CAM SHAFT |
| 2. ANTICLOSE INTERLOCK | 9. MOTOR RATCHET LEVER |
| 3. SPRING RELEASE (CLOSE) LATCH | 10. DRIVE PAWL |
| 4. SPRING CRANK | 11. RACHET WHEEL |
| 5. CLOSING SPRING | 12. HOLDING PAWL |
| 6. CLOSING SPRING FIXED END | 13. SPRING RELEASE (CLOSE) CLAPPER |
| 7. SPRING RELEASE (CLOSE) COIL | 14. CLOSING CAM |



BREAKER OPEN SPRING DISCHARGED

BREAKER OPEN SPRING CHARGED

FIGURE 5.4 CHARGING SPRING SCHEMATIC (LEFT SIDE VIEWS)

5.4.1 CLOSING SPRING CHARGING (Refer to Figure 5.4)

Figure 5.4 shows schematic section views of the spring charging parts of the stored energy mechanism.

The major component of the mechanism is a cam shaft assembly which consists of a hex shaft to which are attached two closing spring cranks (one on each end), the closing cam, drive plate, and a free-wheeling ratchet wheel.

The ratchet wheel (11) is actuated by an oscillating ratchet lever (9) and drive pawl (10) driven by the motor eccentric cam. As the ratchet wheel rotates, it pushes the drive plates which in turn rotate the closing spring cranks and the closing cam on the cam shaft. The motor will continue to run until the limit switch "LS" contact disconnects the motor.

The closing spring cranks have spring ends connected to them which are in turn coupled to the closing springs. As the cranks rotate, the closing springs get charged.

The closing springs are completely charged, when the spring cranks go over dead center and the closing stop roller (14) comes against the spring release latch (3). The closing springs are now held in the fully charged position.

The closing springs may also be charged manually as follows: Insert the maintenance tool in the manual charging socket. Move it up and down several times (about 36) until a clicking sound is heard and closing spring status indicator shows "charged" (Figure 1.1). Any further motion of the maintenance tool will result in free wheeling of the ratchet wheel and will not result into advance of charging.

5.4.2 CLOSING OPERATION

Figure 5.3 shows the positions of the closing cam and tripping linkage for four different operational states. In Figure 5.3a the breaker is open and the closing springs are discharged. In this state, the trip latch is disengaged from the trip "D" shaft (unlatched). After the closing springs become charged, the trip latch snaps into the fully reset or latched position (Figure 5.3b).

When the spring release clapper (13 of Fig. 5.4) moves into the face of the spring release coil (electrically or manually), the upper portion of the clapper pushes the spring release latch (3 of Fig. 5.4) upward. When the spring release latch moves, the cam shaft assembly is free to rotate. The force of the closing cam (8), moving the main link (2), rotating the pole shaft (1) (which charges the opening spring). This moves the three operating rods (9), closes the main contacts and charges the contact loading springs (not shown). The operational state immediately after the main contacts close but before the spring charging motor recharges the closing springs is illustrated in Figure 5.3c.

Interference of the trip "D" shaft with the trip latch prevents the linkage from collapsing, and holds the breaker closed.

Figure 5.3d shows the breaker in the closed state after the closing springs have been recharged. The recharging of the spring rotates the closing cam one half turn. In this position the main link roller rides on the cylindrical portion of the cam, and the main link does not move out of position.

5.4.3 TRIPPING OPERATION

When the trip bar "D" shaft (11) is turned by movement of the shunt trip clapper (5), the trip latch will slip past the straight cut portion of the trip bar shaft and will allow the banana link and main link roller to rise. The energy of the opening spring and contact loading springs is released to open the main contacts. The mechanism is in the state illustrated (Figure 5.3b) after the breaker is tripped open.

5.4.4 TRIP-FREE OPERATION

During the normal closing process, the position of the trip latch (4) and banana link (3) causes the main link roller (10) to move in a fixed arc such that the main link can drive the pole shaft. If the trip latch is released by rotation of the trip bar "D" shaft before or during the closing process, the main link roller rises to a position which prevents the main link from driving the pole shaft (trip free operation). When the manual trip button is held depressed, any attempt to close the breaker will discharge the closing springs, without any movement of the pole shaft or vacuum interrupter stem.

5.5 ELECTRICAL CONTROL

There are two basic control schemes for type DST-2VR replacement breakers with the VCP-WR element; One for DC control and one for AC control. Figure 5.5 shows the basic wiring diagram, and Figure 5.6 shows the DC scheme. These control schemes are for the VCP-W element with DC control power. A solid-state full-wave bridge rectifier is used for breakers which are used in AC control source schemes and the functioning of the breaker is identical to that of the DC source scheme. The complete wiring and schematic diagrams for each vacuum replacement breaker is included in the data pack shipped with the individual breaker. This discussion is intended to familiarize the service engineer or technician with the functional operation of the control scheme.

When the breaker's secondary connector block engages the cell secondary receptacle block, the spring charging motor is expected to run and charge the closing springs. The limit switch "LS", sometimes called the motor cutoff switch, disconnects the motor when the springs are fully extended.

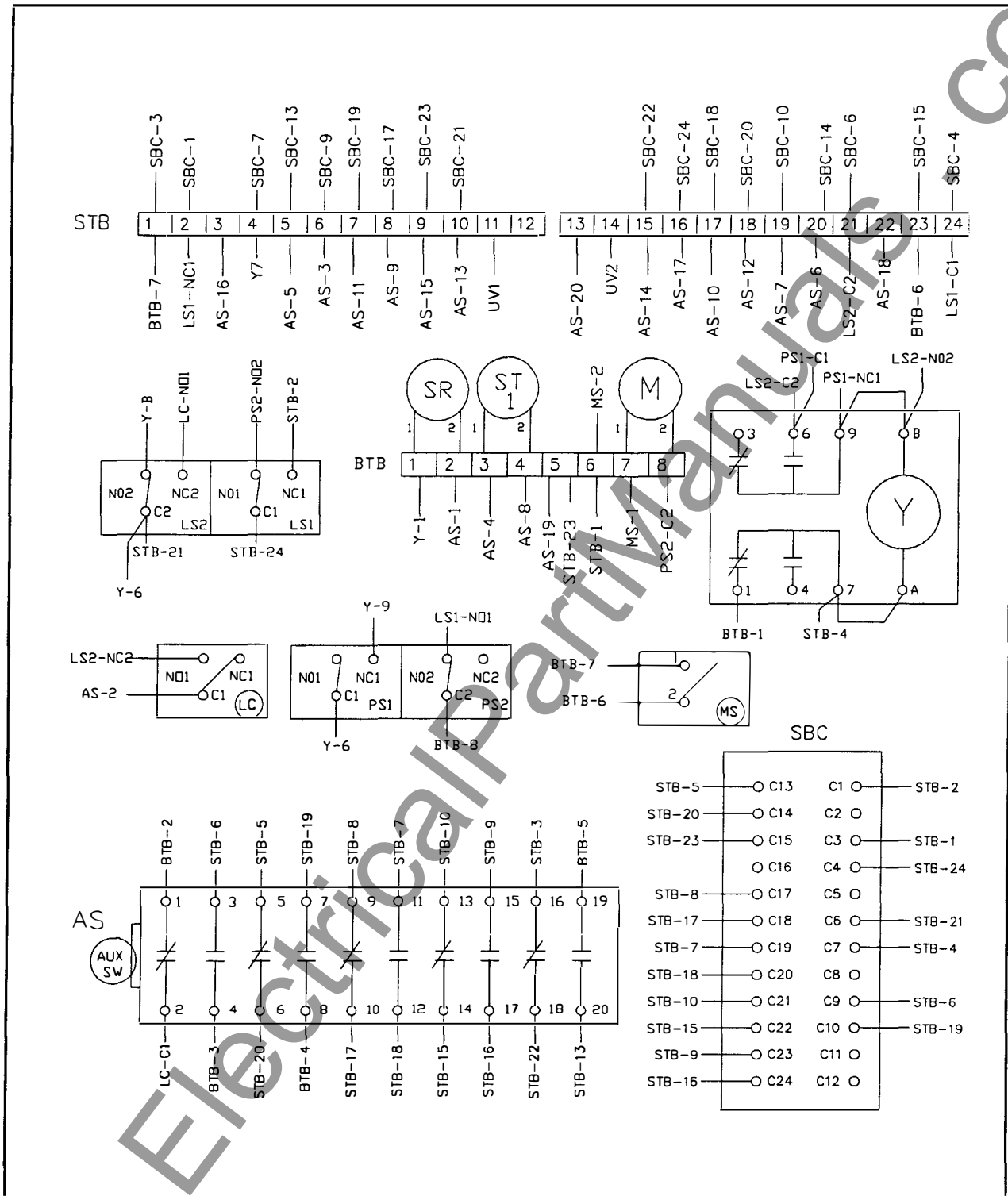

FIGURE 5.5 BASIC WIRING DIAGRAM

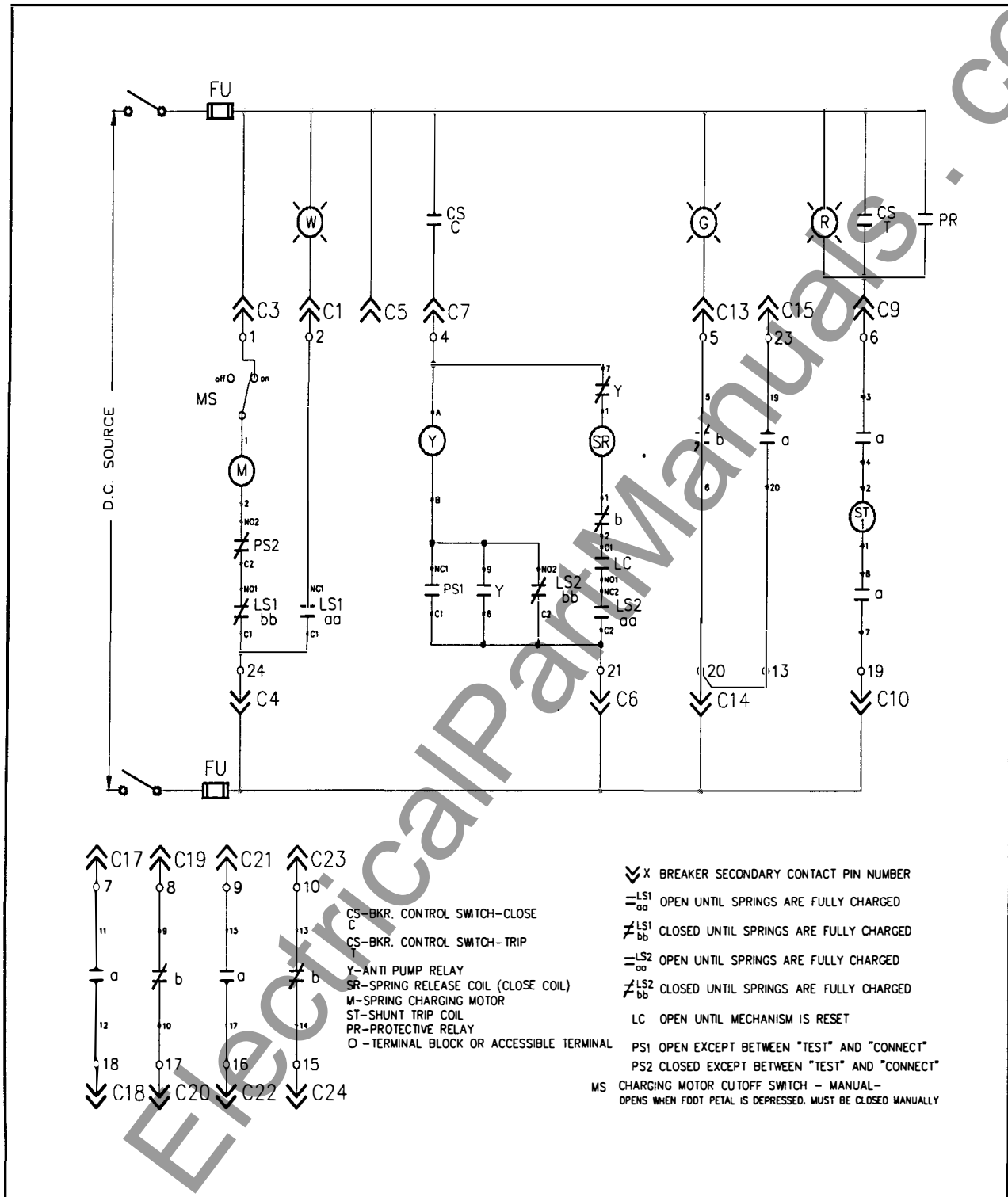

FIGURE 5.6 DC CONTROL SCHEMATIC

The signal to close the breaker is received at pin number "C7". The conditions that are required to energize the "SR" spring release coil are determined by the state of the "Y" relay, "b" switch, "LC" latch check, and "LS2aa" limit switch contacts. The "Y" relay contact interrupts the "SR" spring release circuit if the close signal at pin "C7" has persisted since the last close-open operation of the breaker. The principal function of this "Y" relay is to prevent repeated closing and reopening in the situation where a close signal persists while a breaker is closing a power source onto a faulted feeder circuit (anti-pumping function). The other function of the "Y" relay is to prevent energizing of the "SR" coil whenever the "PS" position switch is closed, most especially for the possibility that an unintentional close signal is present while the breaker is at a cell position between "disconnect" and "connect". The "PS" position switch contact is closed whenever the Levering System mounted tripping cam is holding the trip rod in a raised position. In normal sequence of operation the "Y" relay coil is energized when the "LS" contact closes as the closing springs are discharged to close the breaker. A "Y" contact in parallel with the "LS" contact maintains the "Y" coil energized after the "LS" contact opens on spring recharging. The "b" contact serves to interrupt the "SR" coil as soon as the main contacts close as well as to prevent energizing of the "SR" coil should the breaker be already closed when a close signal is initiated. The "LC" contact permits energizing the "SR" coil only if the trip latch is engaged fully on the trip shaft. The "LS" limit switch contact permits energizing the "SR" only when the closing springs are fully extended (fully charged).

A solid-state full-wave bridge rectifier is used for breakers which are used in AC control source schemes. The functioning of the breaker closing circuit is identical to that of the DC source scheme.

Upon closing the breaker, the spring charging motor "M" automatically begins to run, charging the closing spring.

The signal to open the breaker is received through secondary control block pin "C9". The source of power to energize the "ST" shunt trip relay is the "P" and "N" circuits for the DC control source scheme. The source of tripping power is the "+" and "-" output of a capacitive trip device for AC source control schemes. Two auxiliary switch "a" contacts interrupt the "ST" shunt trip coil circuit as soon as the breaker main contacts open and also prevent energizing of the "ST" coil should the breaker be already open when an opening signal is initiated. For the DC control source scheme, a red light (R) on the switchgear control panel is used as an indication that the breaker is closed, the trip circuit is continuous, and that control source voltage is available for tripping. For AC control source schemes, the red light is controlled by a single "a" contact to indicate that the breaker is closed and AC control power is present.

A green light (G) at the switchgear control panel is controlled by a single "b" auxiliary switch contact and is indication that the breaker is open and control voltage is available.

5.6 SECONDARY CONNECTION BLOCK

The breaker control circuit is connected to the switchgear control through a 24-point secondary connection block (Figure 1.1). The secondary connection block engages as the breaker is levered into the "connect" position, or it can be engaged while the breaker is in the "test" position by releasing the latch and pushing forward on the slider located at the lower right hand of the breaker frame. The latch causes the secondary connection block to disengage whenever the breaker is levered out of the "connect" position.

CAUTION

THE SECONDARY CONNECTION BLOCK SHOULD NOT BE CONNECTED UNTIL THE BREAKER IS LEVERED INTO THE TEST POSITION.

5.7 INTERLOCKS

There are several interlocks built into the CUTLER-HAMMER vacuum replacement DST-2VR breakers. Each of these interlocks performs exactly the same function it did on the original breaker. These interlocks exist to safeguard personnel and equipment. The basic premise behind the interlocking arrangement on the vacuum replacement breaker is that the breaker must not be inserted into or removed from a live circuit while the main contacts are closed. In addition to the original interlocks, the CUTLER-HAMMER type VCP-WR element provides an anti-close interlock.

WARNING

INTERLOCKS ARE PROTECTIVE DEVICES FOR PERSONNEL AND EQUIPMENT. DO NOT BYPASS, MODIFY, OR MAKE INOPERATIVE ANY INTERLOCKS. DOING SO COULD CAUSE DEATH, SERIOUS PERSONAL INJURY, AND/OR PROPERTY DAMAGE.

5.7.1 ANTI-CLOSE INTERLOCK

The anti-close interlock prevents discharging of the closing springs if the breaker is already closed (Figure 5.4, Item 2). When the breaker is closed, the interlock component moves away from the spring release clapper so that it cannot lift the spring release latch (3).

5.7.2 LEVERING INTERLOCK (FLOOR TRIP/INTERLOCK PEDAL)

The levering interlock prevents engaging a shut breaker with live cell buss work or removing a breaker from the cell with charged springs. The basic premise of this interlock is that no breaker should be connected to or removed from cell primary circuitry when shut. The levering interlock accomplishes this by providing a trip signal to the breaker automatically from the floor trip whenever the breaker is in an intermediate position in the cell or manually whenever the Interlock Pedal is depressed.

5.7.3 SHUTTER INTERLOCK

Each Federal Pacific DST-2 cell is equipped with a shutter to shield the high voltage stabs in the cubicle when the breaker is not in the cubicle. The shutter is regulated by a roller located on the underside of the breaker that opens the shutter as the breaker is levered into the cell and closes the shutter as the breaker is levered out of the cell.

5.8 LEVERING SYSTEM TRIP AND SPRING RELEASE INTERLOCKS

The Levering System tripping and spring release interlocks perform the following:

- a. Set the breaker mechanically trip-free whenever the breaker is between the "test" and "disconnect" positions.
- b. Set the breaker in a safe condition (breaker open, springs discharged) when moved between the "test" and the "disconnect" positions.
- c. Insert a mechanical trip signal to open the position switch, preventing the energizing of the spring release coil whenever the breaker is in an intermediate position.
- d. Prevent inadvertent cycling (pumping) of the breaker between the test and connect positions.

5.9 LEVERING SYSTEM & LEVERING HANDLE

The levering system moves the circuit breaker between the "disconnect", "test" and "connect" positions. The levering handle provides leverage enough to overcome the resistance to movement provided by the primary disconnects, secondary connection block terminal engagement and breaker wheels.

The levering handle attaches to the front of the breaker and engages with the cell floor to push the breaker into the cell or draw the breaker from the cell. A very large mechanical advantage is realized because of the long length of the levering handle relative to the driving arm that engages the floor of the cell. Figure 4.1 illustrates the orientation of the levering handle with the breaker and cell. Minimal effort is required to move the breaker from "disconnect" to "connect" position. Care and experience is needed in order to determine whether a more than usual force is required to lever the breaker into a cell, as this might be an indication of a mechanical interference or misalignment of components. If unusual force is noted, the breaker should be withdrawn from the cell and re-examined to determine the reason.

WARNING

DO NOT FORCE THE BREAKER INTO THE CELL. FORCING MAY DAMAGE PARTS THEREBY RISKING DEATH, PERSONAL INJURY, AND/OR PROPERTY DAMAGE.

CELL POSITION DESCRIPTION (See Figure 5.7)

- Position A.** This is the "withdrawn" position. In the "withdrawn" position the breaker is out of the cell. The levering handle is not required for this position and the levering system interlocks are not automatic outside the cell. The breaker can be operated in this position and extreme care should be exercised to avoid inadvertent operation and possible injury or equipment damage.
- Position B.** As the breaker is pushed into the cell it will reach a position where all four wheels are on the cell floor guide rails and the floor spring discharge interlock has not activated. This is the "disconnect" position and the breaker can still be operated because there is no interface of the cell floor interlocks with breaker interlock linkage. No cell labeling is provided to verify this position.
- Position C.** The breaker is advanced into the cell. The depressing of the Interlock Pedal will make this operation easier but due to the cell design, depressing of the Interlock Pedal is not required at this stage. Once movement has started, the Interlock Pedal should be released if depressed. The levering handle may be required to move the breaker completely into the test position and it's use is illustrated in Figure 4.1. The Interlock Pedal will travel down at the beginning of movement and rapidly rise to lock the breaker in the test position at the end of the normal travel from disconnect to test. The movement of the Interlock Pedal provides an open signal that remains throughout all intermediate breaker positions and the floor trip will be recruited for a closing signal between the disconnect and test position to discharge the closing springs and render the breaker trip-free. The breaker

remains in the trip-free state until position "D" (test) is reached.

- Position D.** The test position will be realized when an audible click of the interlock plunger engaging the interlock rail is observed at about 8 inches travel from the disconnect position. In the "test" position, the breaker can be closed and tripped manually and electrically, thus allowing maintenance test or checks. To operate the breaker electrically, the secondary control block must be engaged and the manual motor cutoff switch turned "on".
- Position E.** To continue installing the breaker to the connected position the levering handle will have to be used and the Interlock Pedal depressed. The interlock plunger riding on the interlock rail will provide a continuous trip signal during this intermediate breaker position. The closing springs may be in the charged state but the internal PS switch will open circuit the close spring release coil (preventing an electrical close). At this point any attempt to mechanically close the breaker will cause a trip-free operation. As you continue to advance the breaker into the cell the primary voltage source shutters will open allowing the breaker stabs to engage with the source.
- Position F.** The "connect" position is achieved by moving the breaker into the cell using the levering handle for about 8 inches of travel (from the test position) until a mechanical stop is reached. As you continue to advance the breaker into the cell the primary voltage source shutters will open allowing the breaker stabs to engage with the source. This is the fully engaged or connected position. The connect position can be verified by the inability to move the breaker in or out, the Interlock Pedal has released the trip mechanism and is up, and the cell label "operating" is visible on the floor of the cell in front of the breaker's left front wheel. The breaker is now ready for service.

CAUTION

DO NOT USE ANY TOOL TO LEVER THE BREAKER FROM TEST OR CONNECTED POSITION OTHER THAN THE LEVERING HANDLE. (Figure 4.1)

- Position G.** To remove the breaker from the cell it must be in the open position. Lever the breaker in the outward direction. Also, the secondary control stabs will disengage before the main stabs are disconnected. The breaker is in a non-operate mode and will go through a trip free operation if an attempt to close it were made. Continue levering the breaker out, and the shutters will close after the main stabs have cleared, isolating the breaker from its source.
- Position H.** Continue levering until the Interlock Pedal has again risen and locked the breaker in the test position. The breaker is now in the test position and the

trip mechanism is released, allowing the breaker to be operated either electrically or mechanically. To operate electrically, the secondary control block must be re-engaged and the manual cutoff switch turned "on".

- Position I.** To remove the breaker from the test position to the disconnected position, the breaker must be tripped if closed, the Interlock Pedal must be depressed, and the secondary contact block should be disengaged. When moving out of the test position, a floor close signal will combine with the trip signal from the Interlock Pedal to force a trip-free condition. This will cause the charging springs to discharge leaving the breaker in the open position and the closing springs discharged. The breaker is in a non-operable state.
- Position J.** Once the breaker is withdrawn past the floor trip activation area, it is in the disconnected position. All the wheels are on the guide rails and the spring discharge linkage has just cycled. The breaker can still be operated mechanically because there is no interface of the cell floor interlocks with breaker interlock linkage. No mechanical stop will be reached and no cell labeling is provided to verify this position. The breaker is ready to be removed from the cell if desired.
- Position K.** The breaker is removed from the cell and in the withdrawn position. The levering handle is not required for this position and the levering system interlocks are not automatic outside the cell. The breaker can be operated in this position and extreme care should be exercised to avoid inadvertent operation and possible injury or equipment damage.

5.10 GROUNDING CONTACT

The grounding contact is an assembly of two spring loaded fingers which ground the breaker frame by engaging the switchgear cell grounding bus when the breaker is levered into the "connect" position. The ground contact is located at the rear of the breaker near the floor and visible from the back of the breaker when out of the cell.

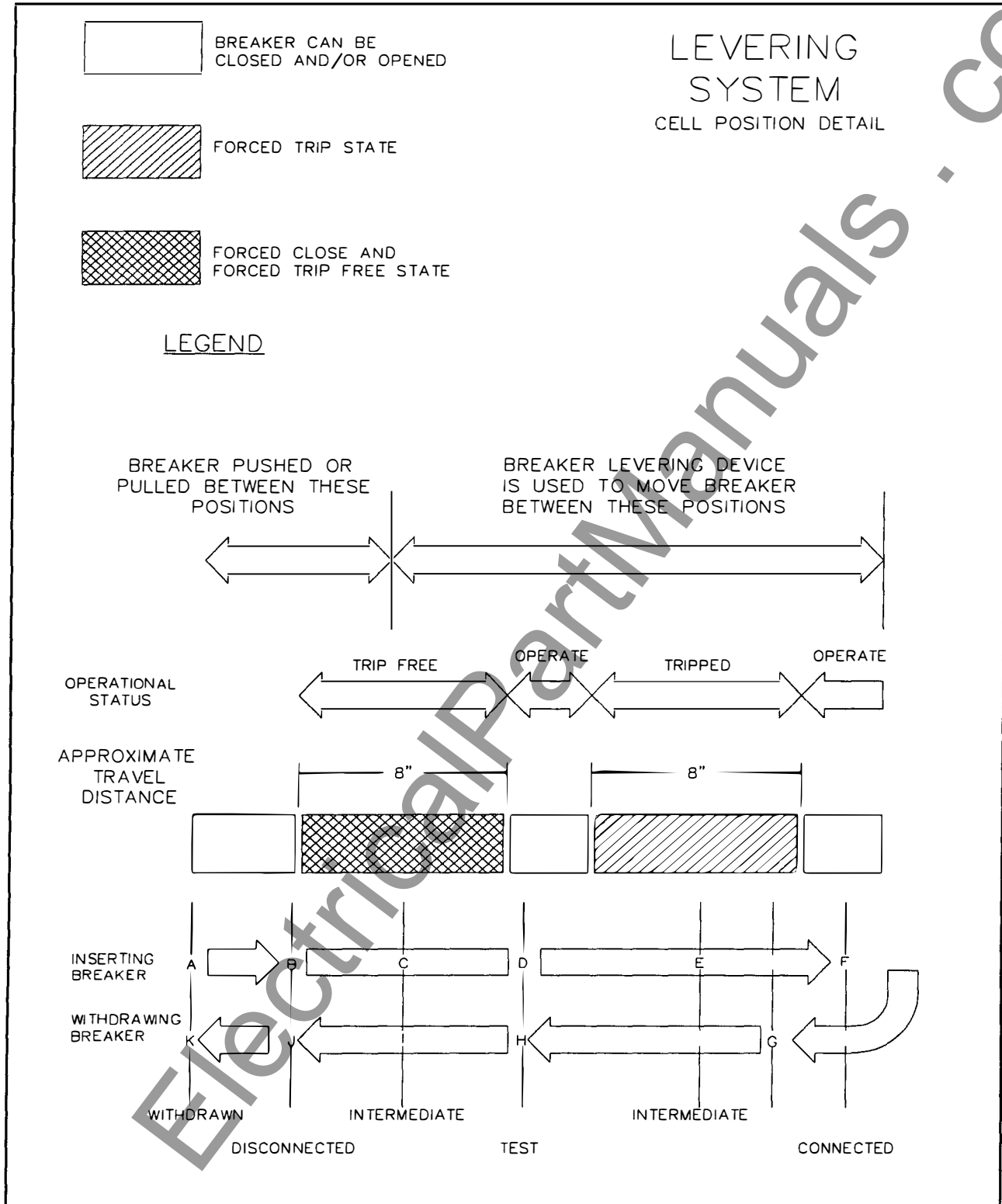

FIGURE 5.7 LEVERING SYSTEM FOR BREAKER IN CELL

SECTION 6 - MAINTENANCE AND INSPECTION

6.1 SAFE WORK CONSIDERATIONS

- * Review and follow the safe practices set forth in Section 2.
- * Do not work on a breaker in the "connected" position.
- * Do not work on a breaker with secondary connecting block engaged.
- * Do not work on a breaker with springs charged or contacts closed.
- * Do not defeat any interlocks.
- * Do not leave the maintenance tool in the spring charge opening after manually charging the closing springs.

WARNING

FAILURE TO FOLLOW THESE DIRECTIONS OR THOSE IN SECTION 2 MAY RESULT IN DEATH, SERIOUS BODILY INJURY AND/OR PROPERTY DAMAGE.

6.2 FREQUENCY OF INSPECTION

The circuit breaker should be inspected before initiation into service and after the first six-month period in service.

Under non-fault interrupting conditions, it is recommended that the breaker be inspected once annually or according to the following table, whichever comes first.

<u>CIRCUIT BREAKER RATINGS</u>	<u>OPERATIONS BETWEEN SERVICING</u>
4.76 through 15kV, 29kA and below, 2000 amperes and below	2000
4.76kV, 1200 through 3000A, 41 ka 15kV, 1200 through 3000A, 37 ka	1000

These operations can be either no-load mechanical, load current switching, bulk capacitor

or reactor switching operations, or motor starting applications.

Severe service conditions require more frequent inspections.

For complete information regarding maintenance periods, refer to ANSI C37.06 - 1987 Table 8.

It is important to thoroughly inspect and electrically test the breaker before returning the breaker to service if it interrupts a faulted circuit.

Maintenance consists of cleaning, adjusting, lubricating, and tightening of accessible bolts, units, and screws as described further in this section.

As operational experience and maintenance test and inspection records are developed, the schedule should be adjusted.

6.3 VACUUM INTERRUPTER INTEGRITY TEST

Satisfactory performance of the vacuum interrupters depends on regular checks of vacuum integrity. An applied potential test of 15kV AC RMS, 60 Hz applied for one minute across the terminals of open interrupters should be performed to confirm vacuum integrity for continued service for 5kV breakers. An applied potential test of 21kV AC RMS, 60 Hz should be applied for 7.5 kV and 15 kV breakers. During this test, the following precaution must be observed:

WARNING

APPLYING HIGH VOLTAGE ACROSS A PAIR OF CONTACTS IN VACUUM MIGHT PRODUCE X-RADIATION. THE RADIATION INCREASES WITH AN INCREASE IN VOLTAGE OR DECREASE IN CONTACT SPACING. X-RADIATION PRODUCED DURING THIS TEST WITH RECOMMENDED VOLTAGE AND NORMAL CONTACT SPACING IS EXTREMELY LOW AND WELL BELOW MAXIMUM PERMITTED BY STANDARDS. HOWEVER, AS A PRECAUTIONARY MEASURE AGAINST THE POSSIBLE APPLICATION OF HIGHER THAN RECOMMENDED VOLTAGE OR LESSER THAN NORMAL CONTACT SPACING, IT IS RECOMMENDED THAT ALL PERSONNEL STAND AT LEAST ONE METER AWAY FROM AND IN FRONT OF THE BREAKER WHENEVER HIGH VOLTAGE IS APPLIED FOR TESTING.

Conduct the vacuum integrity test with the breaker contacts open. Electrically connect all top primary conductors together and to one high voltage terminal of the test set. Connect all bottom conductors together to the other terminal of the test set and to the grounded circuit breaker frame. Connect all secondary (control circuit) contacts together and to the grounded frame of the breaker. Starting at zero, increase the applied potential to 15/21kV

AC, at the uniform rate of no more than 750 volts/second, and maintain this voltage for one minute, then return the voltage to zero at the uniform rate of no more than 750 volts/second. Before touching or handling any of the breaker or test set components, discharge any remaining electrical charge by temporarily grounding the interrupter terminals and the center shield of each interrupter.

The judgment criteria for this test is that all three interrupters must be capable of withstanding the applied over-potential without breakdown. If there is a breakdown, defective interrupters should be identified by an individual test, then the defective interrupter assemblies should be replaced and retested before returning the breaker to service.

To avoid ambiguity in the AC applied potential test due to leakage or displacement (capacitive) current, the test set should have sufficient volt-ampere capacity. It is recommended that equipment be capable of delivering 25 milliamperes for one minute at the 15/21kV voltage level (375/525 volt-ampere rating, respectively).

The AC applied potential test is recommended as most effective. A DC test may be performed if no AC test set is available. In this case, 21kV DC for the 5kV breaker, or 40kV DC for 7.5kV and 15kV breakers, should be applied for one minute, and the test equipment should be capable of delivering 5 milliamperes current for one minute to avoid ambiguity due to leakage or field emission currents. Because of the physical nature of vacuum interrupters, the amount of leakage current indicated on the DC test set cannot be used in judging the test result nor for comparison purposes. The single judgment criteria is that there is no breakdown during the one minute application of over-potential.

CAUTION

SOME DC HIGH POTENTIAL TEST DEVICES HAVE UNFILTERED VOLTAGE OUTPUT WHICH ARE NOT SUITABLE FOR TESTING VACUUM INTERRUPTERS BECAUSE THE PEAK VOLTAGE APPEARING ACROSS THE INTERRUPTERS CAN BE SUBSTANTIALLY GREATER THAN THE VALUE READ ON THE METER. FAILURE TO FOLLOW THESE DIRECTIONS MAY CAUSE THE INTERRUPTER TO APPEAR TO HAVE FAILED THE TEST WHEN IN FACT IT CORRECTLY PASSED.

If a test set of less than 25mA AC or 5mA DC rating is the only set available, vacuum interrupters may be tested individually. Connect all other interrupter terminals to the grounded breaker frame when testing individually. If individual VI's are tested, test current capability may be one third of these values.

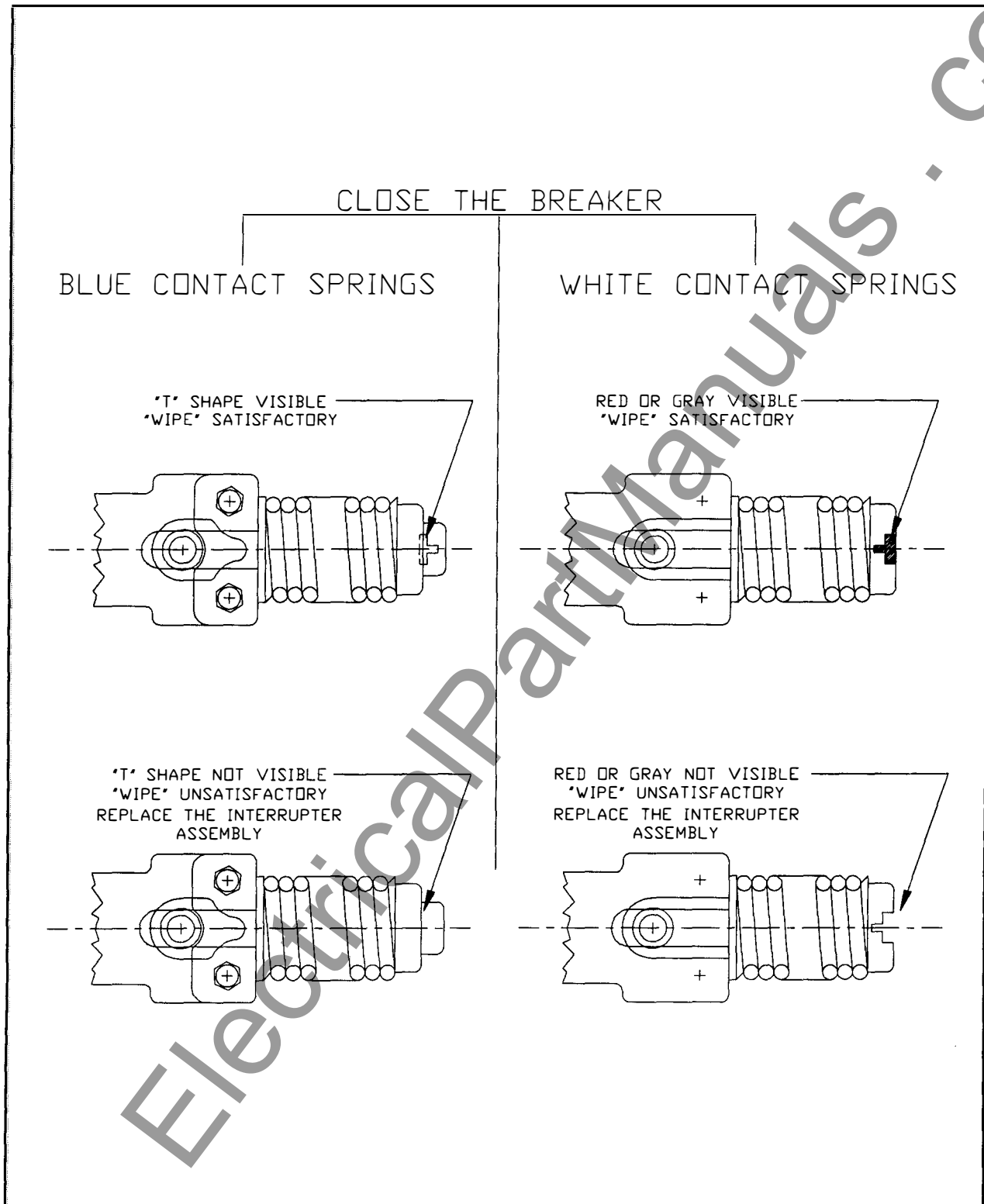

FIGURE 6.1 CONTACT WIPE DETERMINATION

6.4 CONTACT EROSION CHECKS

The main contacts are inside the interrupter and require no maintenance readjustments. However, during high current interruptions there is a small amount of erosion of the contact surfaces. Maximum allowable erosion during the usable lifetime of the interrupter is 1/8 inch. To measure contact erosion, close the breaker and visually inspect each vacuum interrupter moving stem from the rear of the breaker. If the erosion indicator mark is visible (See Figure 5.1), erosion has not reached the service limit. If the mark is not visible, vacuum interrupter assembly replacement is required.

The adequacy of contact wipe can be determined by simply observing the vacuum interrupter side of the operating rod assembly on a closed breaker. Figure 6.1 shows the procedure for determining the contact wipe. If the wipe is not adequate, the vacuum interrupter assembly (Pole Unit) must be replaced. Field adjustment is not possible. (See Section 7 for Replacement Procedure).

WARNING

FAILURE TO REPLACE A VACUUM INTERRUPTER ASSEMBLY WHEN CONTACT EROSION MARK IS NOT VISIBLE OR WIPE IS UNSATISFACTORY, WILL CAUSE THE BREAKER TO FAIL TO INTERRUPT AND THEREBY CAUSE PROPERTY DAMAGE OR PERSONAL INJURY.

6.5 CLEANING

All insulation surfaces, including vacuum interrupters, should be maintained clean and dry. Cleaning is normally performed by wiping all insulating surfaces with a dry, lint free cloth. In cases where tightly adhering dirt cannot be removed by wiping, a mild chemical solvent such as Stoddards solvent (Cutler-Hammer 55812CA) or distilled water can be used to wet the wiping cloth. But be sure that the surfaces are dried immediately after cleaning.

6.6 SECONDARY WIRING INSPECTIONS

The secondary wiring should be inspected for damage to the insulating jacket of the conductors. Terminal strip hardware and compression-type wire terminations should be checked for tightness.

6.7 INSULATION INTEGRITY TESTS

The following tests will check both primary and secondary insulation integrity.

6.7.1 PRIMARY CIRCUIT INSULATION TESTS

The integrity of primary insulation should be checked with an applied potential test. For breakers rated at 4.76kV, 8.25kV, and 15kV, the test voltages are 15kV, 21kV, and 21kV AC RMS, 60 Hz respectively applied for one minute. Before conducting the test, be sure that vacuum interrupters and insulation have been carefully cleaned by wiping them down, and that all four phase barriers are in place and the breaker main contacts are closed. Electrically connect one high voltage terminal of the test set to an upper or lower terminal of one interrupter connect the other terminal of the test set and all remaining interrupter terminals to the grounded frame of the breaker. Raise the test potential from zero to the test level, maintain the test voltage for one minute, and lower the voltage to zero. Before handling or touching any breaker component, discharge all the interrupter terminals and static shields by temporarily connecting each to the grounded frame of the breaker. Reconnect the test set and apply the test over-potential to the other two interrupters in the same fashion. The judgment criteria is that all primary circuits withstand the over-potential without breakdown. To assure that the breaker is in a safe condition after this test, open the circuit breaker and check that opening springs and closing springs are discharged.

The AC applied potential test is recommended as most effective. A DC test may be performed if no AC test set is available. In this case, breakers rated at 4.76kV, 8.25kV, and 15kV are tested at voltages of 21kV, 40kV, and 40kV DC respectively applied to each pole in a manner similar to the AC test for one minute. A DC test set which incorporates a capacitor-filtered high voltage circuit should be used to assure that voltage peaks are not greater than the DC average value indicated on the test set's built-in volt meter.

6.7.2 SECONDARY CIRCUIT INSULATION TEST

Temporarily disconnect the spring charging motor's leads. Electrically connect together all contacts of the secondary disconnect block. Apply 1125 Volts AC RMS, 60Hz test set potential between the secondary disconnect block and the grounded breaker frame for one minute. Temporarily ground the secondary circuit to assure that no charge remains, remove the temporary electrical connections made at the contact block, and reconnect the motor leads.

6.8 PRIMARY CIRCUIT RESISTANCE TEST

Measure the resistance of each interrupter circuit from the top bushing terminal to the lower bushing terminal. The primary disconnect finger clusters should not be included in the circuit for this measurement because the finger springs do not bear correct pressure when the breaker is not connected to the bus terminals of the switchgear cell. Primary resistance for each of the three breaker primary circuits should not exceed 60 and 30 micro-ohms for 1200 and 2000 amp. breakers respectively when measured at the bolted bus connections nearest to the vacuum interrupter. This judgment criteria is based on the use of a low-resistance ohmmeter which delivers 100 DC amperes or more during the measurement. **Temperature corrected measurements taken between the end of the line and load bushings should be within 10% of the recorded line to load production test values as recorded on the test data sheets included with each breaker.**

6.9 MECHANISM INSPECTIONS

Inspect the breaker once a year when operating in a clean, non corrosive environment. For a dusty and corrosive environment, inspection should be performed twice a year. Additionally, it is recommended to inspect the breaker every time it interrupts fault current.

Make a careful visual inspection of the mechanism for loose parts such as bolts, nuts, pins, and rings. Check for signs of excessive wear or damage to the mechanism components. Contact CUTLER-HAMMER Engineering Service to repair worn or damaged components. Operate the breaker open-close-open several times manually and electrically to make certain the operation is consistent and reliable.

The brushes in the spring charging motor should be replaced every 5000 close-open operations of the breaker.

Check that the operations counter advances one count for each open-close operation.

6.10 LUBRICATION

All parts that require lubrication in the breaker element have been lubricated during the assembly with molybdenum disulfide grease, Cutler-Hammer material No. 53701QB. Over a period of time, this lubricant may be pushed out of the way, or degrade. Proper lubrication at regular intervals is essential for maintaining the reliable performance of the mechanism. Once a year or every 2000 operations whichever comes first, the breaker should be relubricated. The locations shown in Figure 6.3 should be lubricated with a drop of light machine oil such as Mobil 1, and the points shown on Figure 6.2 with 53701QB grease.

Roller bearings are used on the pole shaft, the cam shaft, the main link and the motor eccentric. These bearings are packed at the factory with a top grade slow oxidizing grease which normally should be effective for many years. They should not be disturbed unless there is definite evidence of sluggishness, dirt, or parts are dismantled for some reason.

If it becomes necessary to disassemble the mechanism, the bearings and related parts should be thoroughly cleaned of old grease with a good grease solvent. Do not use carbon tetrachloride. They should then be washed in light machine oil until the cleaner is removed. After the oil has been drawn off, the bearings should be packed with Cutler-Hammer material 53701QB or equivalent.

The general technique for relubrication is to remove the old lubricant material which can be reached without disassembly of mechanism components, apply a small amount of lube at the surface of each specified location and operate the breaker several times (close and open) to allow the lubricant to work into sliding joints. Excess lubricant should then be wiped from all surfaces.

6.11 PRIMARY BUSHING AND DISCONNECT (FINGER CLUSTER) INSPECTION

Visually inspect the upper and lower bushings for cracks and/or separation of insulating materials from the copper conductors. Remove the six primary disconnecting finger clusters and inspect all surfaces that carry current for signs of burning, pitting, or discoloration which indicates overheating. Primary disconnects which have been overheated will not be able to sustain sufficient pressure on the contact fingers for carrying load current. Overheated disconnects must be replaced.

6.12 SECONDARY CONTACT BLOCK INSPECTION

Visually inspect the contact block for cracked, broken, deformed, or otherwise damaged components. Recheck that all control circuit connecting terminals are tight. Examine the contact surfaces of each pin and ensure that dirt or other contaminants have not built up. If contact surfaces are not clean, they should be cleaned with a soft cloth.

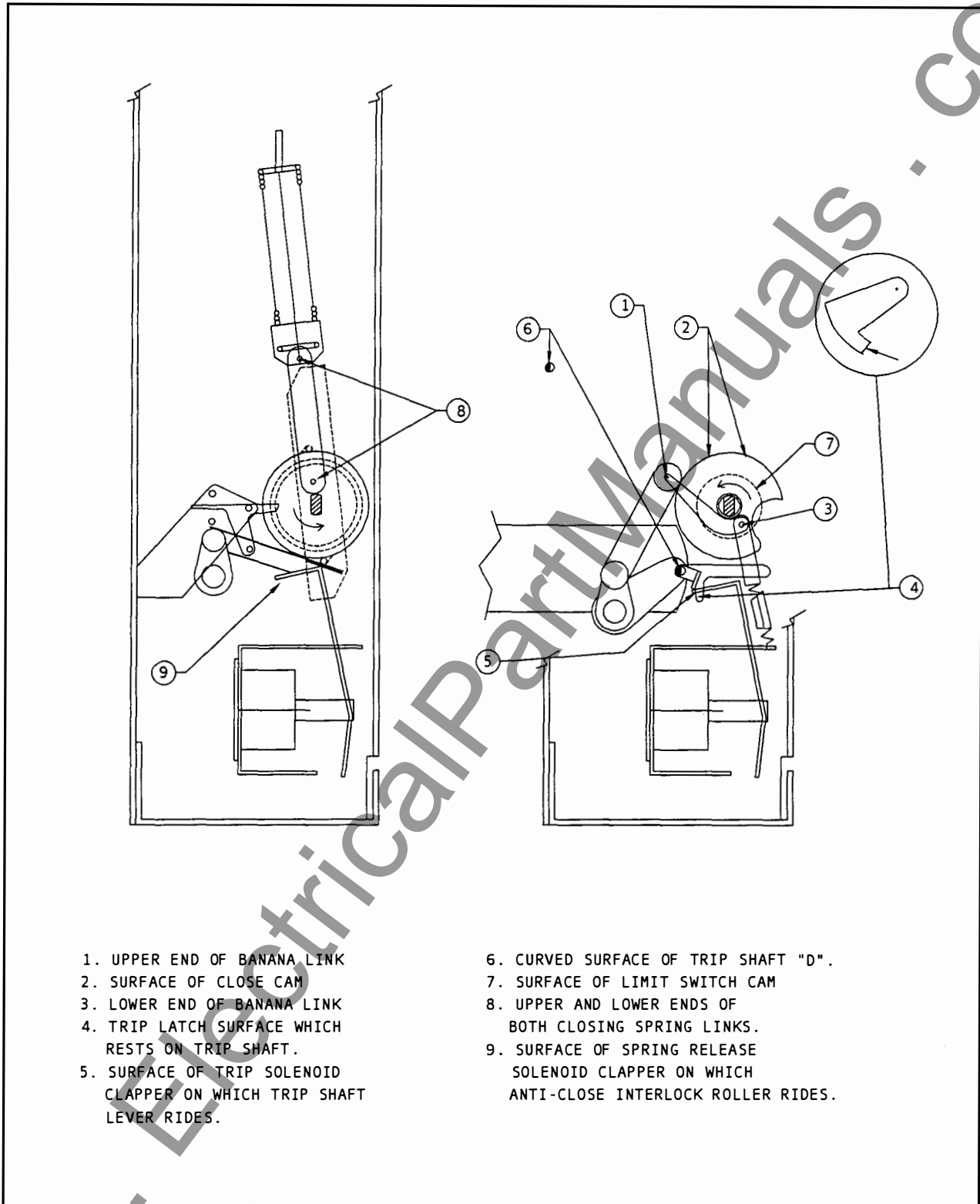

FIGURE 6.2 RELUBRICATION GUIDE (GREASE)

● APPLY ONE DROP OF LIGHT MACHINE OIL SUCH AS MOBIL 1 AT LOCATIONS SHOWN

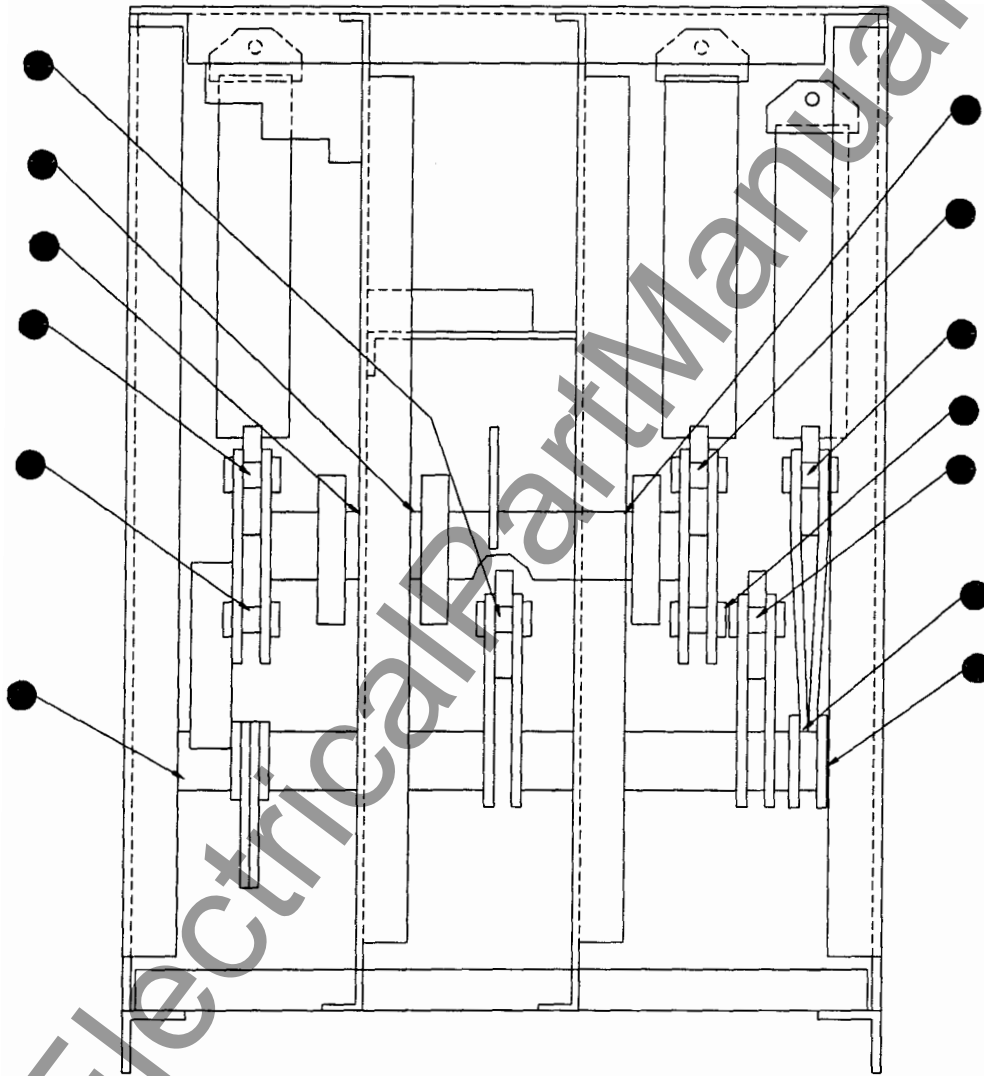

FIGURE 6.3 RELUBRICATION GUIDE (OIL)

6.13 TROUBLESHOOTING GUIDE

WARNING

TRUBLESHOOTING SHOULD BE CONDUCTED BY A CUTLER-HAMMER SERVICE ENGINEER OR OTHER QUALIFIED PERSON.

TROUBLEPOSSIBLE CAUSE

VACUUM REPLACEMENT BREAKER IS DIFFICULT TO LEVER IN CUBICLE

Excessive force required on levering handle shaft.

Wheels not rolling freely; they require adequate lubrication. See Section 6.10 for proper lubricating instructions.

Finger clusters not lubricated. Apply thin coat of petroleum jelly to contact surface of fingers in the cluster.

BREAKER FAILS TO CLOSE

Closing springs not charged.

CONTROL CIRCUIT AREA

Control power failure.

Open circuit at secondary disconnect block. (Fig. 1.1)

"LS" limit switch open or operating lever deformed. (Fig. 5.2)

Spring charging motor brushes worn beyond usable length.

Spring charging motor failure.

MECHANISM

Holding pawl, drive pawl, ratchet wheel, or drive plate broken or worn. (Fig. 5.4)

Cam shaft jammed. (Fig. 5.4)

Ratchet lever reset spring broken or disconnected. (Fig. 5.4)

BREAKER FAILS TO CLOSE

Closing spring charged, but spring release solenoid does not operate electrically.

CONTROL CIRCUIT AREA (Fig. 5.5)

Spring release coil rectifier open or short circuit (AC control version only).

Spring release coil circuit interrupted at "Y", "LS", "b", "LC"

Spring release coil open circuit or has shorted turns.

MECHANISM

"LC" latch check switch operating lever bent or broken. (Fig. 5.2)

Trip latch not engaged on trip shaft; trip solenoid clapper not returned to reset position, main and pole shaft not fully "open" position, trip latch reset springs damaged or disconnected. (Fig. 5.3)

"LS" limit switch open or operating lever deformed.

MECHANISM (Fig. 5.3)

Trip shaft worn.

Trip latch worn.

Trip lift rod jammed.

Trip solenoid clapper not reset.

Trip shaft reset spring disconnected, broken, or missing.

Electrical trip signal absent from switchgear control.

Closing springs discharge on "close" signal, but breaker does not close.

BREAKER CLOSSES UNEXPECTEDLY

Breaker closes immediately as it levered into "connect" position with closing signal from switchgear.

Breaker closes in "connect" position after tripping or after closing springs charge with closing signal from switchgear.

Malfunction of "surprise closing" devices: position switch "PS" or levering interlock or "Y" relay.

Spring release latch failing to reset.

Spring release lift rod jammed.

Malfunction of "anti-pump" devices: limit switch "LS" or "Y" relay.

Spring release latch failing to reset.

Spring release lift rod jammed.

Breaker closes in any position without a closing signal.

BREAKER FAILS TO TRIP

Trip solenoid does not operate.

Spring release latch failing to reset.

Spring release lift rod jammed.

CONTROL CIRCUIT AREA

Control power failure.

Switchgear capacitive trip device failure (capacitor trip versions only).

Open in trip coil circuit at "a" contact of auxiliary switch.

Trip coil open circuit or has shorted turns.

BREAKER FAILS TO TRIP

Trip solenoid clapper moves, but breaker does not trip.

Breaker mechanism trips open, but one or more interrupters fail to break primary circuit.

MECHANISM AREA (Fig. 5.3)

Trip shaft or trip latched jammed.

Pole shaft jammed.

Operating rod broken or pin missing.

Interrupter contact welded closed.

BREAKER TRIPS UNEXPECTEDLY

Trip shaft reset spring disconnected, missing, or broken.

Trip latch worn.

Trip shaft worn.

Protective relay miscoordination or misapplication.

6.14 INSPECTION AND MAINTENANCE

<u>AREA</u>	<u>INSPECTION ITEM</u>	<u>CRITERIA</u>	<u>INSPECTION METHOD</u>	<u>CORRECTIVE ACTION IF NECESSARY</u>
INSULATION	Insulator housing, operating rods, tie-bars and barriers	No dirt	Visual check	Clean with lint-free cloth
		No cracking	Visual check	Replace cracked unit
INSULATION INTEGRITY	Main circuit to Ground	Withstand test voltage for 1 minute	Hipot Tester (Sect. 6.7.1)	Clean and retest or replace
	Between Main Circuit Terminals	Withstand test voltage for 1 minute	Hipot Tester (Sect.6.7.1)	Clean and retest or replace
	Control Circuit to Ground	Withstand 1125VAC (60Hz) for 1 minute	Hipot Tester (Sect. 6.7.2)	Clean and retest or replace
POWER ELEMENTS	Vacuum Interrupters	Contact Erosion visibility of mark	Visual-Close the breaker and look for green mark on moving stem from the rear of the breaker (see Fig. 5.1)	If mark is not visible, replace interrupter assembly
		Contact wipe visible	Visual (Fig. 6.1)	Replace VI assembly
		Adequate vacuum	See Section 6.3	Replace interrupter assembly if vacuum is not adequate
		Dirt on ceramic body	Visual check	Clean with dry lint-free cloth
	Primary Disconnects	No burning or damaged	Visual check	Replace if burned, or eroded
CONTROL CIRCUIT	Closing and tripping devices including disconnects	Smooth and correct operation by control power	Test closing and tripping of breaker twice	Replace any defective device- identify per troubleshooting PARTS chart
	Wiring	Securely tied in proper place	Visual check	Repair or tie as necessary
	Terminals	Tight	Physical check	Tighten or replace if necessary
	Motor	At-5000 Operations	Check Counter	Replace brushes
OPERATING MECHANISM	Tightness of hardware	No loose missing parts	Visual and tightening with appropriate tools	Tighten or reinstate if necessary
	Dust or foreign matter	No dust or foreign matter	Visual check	Clean as necessary
	Lubrication	Smooth operation no excessive wear	Sight and feel	Lubricate sparingly with light machine oil
	Deformation or excessive wear	No excessive deformation or wear	Visual and operational	Remove cause and replace parts
	Manual operation	Smooth operation	Manual charging, closing, and tripping	Correct per troubleshooting chart if necessary

TYPE OF JOINT	STEEL		COPPER		MOLDED BAKELITE	
	TORQUE IN FOOT POUNDS					BOLT DIA. AND THREAD TYPE
	1/4-20	5/16-18	3/8-16	7/16-14	1/2-13	
STEEL BOLT & NUT 	8	17	30	50	75	
STEEL BOLT INTO STEEL THREAD 	8	17	30	50	75	
STEEL BOLT & NUT COPPER STOCK 	5	12	20	30	50	
STEEL BOLT INTO COPPER THREAD 	5	10	15	25	40	
STEEL BOLT & NUT BAKELITE & COPPER 	—	—	15	—	40	
PRIMARY BUSHING	1200 AMP		DST-2VR			
BUSHING MOUNT	—	—	—	—	15	
PRIMARY DISC.	—	12	—	—	—	
PRIMARY BUSHING	2000 AMP		DST-2VR			
BUSHING MOUNT	—	—	—	—	25	
PRIMARY DISC.	—	12	—	—	—	

FIGURE 6.4 TORQUE SPECIFICATION CHART

SECTION 7 - RENEWAL PARTS

In order to minimize production downtime, it is recommended that an adequate quantity of spare parts be carried in stock. The quantity will vary from customer to customer, depending upon the service severity and continuity requirements. Each customer should develop his own stock level based on operating experience. The table of items below may be used as a guide.

7.1 RENEWAL PARTS ORDERING INFORMATION

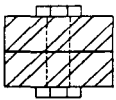
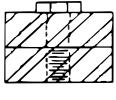
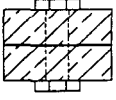
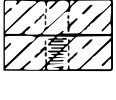
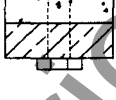
- * Always specify breaker rating information and shop order or G.O. number. For Nuclear Safety Related breakers the nameplate serial number is followed by a "-1E", and should so be noted on inquiries.
- * Describe the item, give style number and voltage (for electrical components) or G.O. number. Specify the quantity and preferred method of shipment.
- * Send all orders or correspondence to the nearest CUTLER-HAMMER Engineering Service office listed at the end of this manual.

7.2 RECOMMENDED SPARE PARTS

Quantities are recommended per 5 units. Where no quantity is given, part number is provided for ordering information only.

RECOMMENDED MECHANICAL SPARE PARTS				
SPARE PART	DST-2VR250 (4.76kV)	DST-2VR350 (4.76kV)	DST-2VR500/750 (8.25kV & 15kV)	QUANTITY
<u>Shock Absorber</u>	5677B26H01	5677B26H01	5677B26H01	
<u>Trip Latch (Hatchet)</u>	699B040G03	699B040G03	699B040G03	
<u>Labels Kit (Element)</u>	8295A45G01	8295A45G01	8295A45G01	1
<u>Trip D Shaft</u>	694C638G01	694C638G01	694C638G01	
<u>Shutter Roller</u>	7962D86030	7962D86030	7962D86030	

Moc Fork	7962D79004	7962D79004	7962D79004	1
Phase Barrier Inner Outer	5677B34H01 7962D72001	5677B36H01 7962D72001	5677B34H01 & 7962D02003 7962D02001	

RECOMMENDED ELECTRICAL SPARE PARTS				
SPARE PART	DST-2VR250 (4.76kV)	DST-2VR350 (4.76kV)	DST-2VR500/750 (8.25kV & 15kV)	QTY.
Primary Disc. (1200A)	B0370G01	B0370G01	B0370G01	2
Primary Disc. (2000A)	FPE 1551B5675	FPE 1551B5675	FPE 1551B5675	2
Secondary Disconnect (16 Pin)	Thomas & Betts MS 216	Thomas & Betts MS 216	Thomas & Betts MS 216	1
Secondary Disconnect (24 Pin)	Thomas & Betts MS 224	Thomas & Betts MS 224	Thomas & Betts MS 224	1
Ground Contact	7961D07003	7961D07003	7961D07003	1
Auxiliary Switch	5697B02G02	5697B02G02	5697B02G02	
Charging Motor 48 VDC 125 VDC / 120 VAC 250 VDC / 240 VAC	699B196G06 699B196G04 699B196G05	699B196G06 699B196G04 699B196G05	699B196G06 699B196G04 699B196G05	1
Motor Brush Kit	8063A77G01	8063A77G01	8063A77G01	1
Spring Release Coils 48 VDC 125 VDC / 120 VAC 250 VDC / 240 VAC	3759A76G11 3759A76G12 3759A76G13	3759A76G11 3759A76G12 3759A76G13	3759A76G11 3759A76G12 3759A76G13	1
Rectifier (A.C. Close Only) 120 / 240 VAC	3759A79G02	3759A79G02	3759A79G02	1

Anti-Pump (Y) Relay 48 VDC 125 VDC 250 VDC 120 VAC 240 VAC	8237A27H03 8237A27H04 8237A27H05 8237A27H01 8237A27H02	8237A27H03 8237A27H04 8237A27H05 8237A27H01 8237A27H02	8237A27H03 8237A27H04 8237A27H05 8237A27H01 8237A27H02	1
Shunt Trip Coils 48 VDC 125 VDC / 120 VAC 250 VDC / 240 VAC	3759A76G11 3759A76G12 3759A76G13	3759A76G11 3759A76G12 3759A76G13	3759A76G11 3759A76G12 3759A76G13	1
UV Trip Coils 48 VDC 125 VDC 250 VDC 120 VAC 240 VAC	8064A19G01 8064A19G02 8064A19G03 701B615G07 701B615G08	8064A19G01 8064A19G02 8064A19G03 701B615G07 701B615G08	8064A19G01 8064A19G02 8064A19G03 701B615G07 701B615G08	1
Motor Cutoff Switch	5677B02G11	5677B02G11	5677B02G11	1
Manual Motor Cutoff Switch	8396K108	8396K108	8396K108	1
Latch Check Switch	699B147G01	699B147G01	699B147G01	1
Position Switch 1 Position Switch 2	699B147H01 3759A93H02	699B147H01 3759A93H02	699B147H01 3759A93H02	1

VCP-WR SERIES 18 SPARE ELEMENT STYLE NUMBER (4.76kV)					
CONTROL VOLTAGE		DST-2VR250 4.76kV, 1200A	DST-2VR250 4.76kV, 2000A	DST-2VR350 4.76kV, 1200A	DST-2VR350 4.76kV, 2000A
CLOSE & MOTOR	TRIP	ELEMENT STYLE	ELEMENT STYLE	ELEMENT STYLE	ELEMENT STYLE
48 VDC	48 VDC	3A74502G01	3A74503G01	3A74505G01	3A74506G01
125 VDC	125 VDC	3A74502G02	3A74503G02	3A74505G02	3A74506G02

250 VDC	250 VDC	3A74502G03	3A74503G03	3A74505G03	3A74506G03
120 VAC	48 VDC	3A74502G04	3A74503G04	3A74505G04	3A74506G04
240 VAC	48 VDC	3A74502G05	3A74503G05	3A74505G05	3A74506G05
120 VAC	CAP (120V)	3A74502G06	3A74503G06	3A74505G06	3A74506G06
240 VAC	CAP (240V)	3A74502G07	3A74503G07	3A74505G07	3A74506G07

VCP-WR SERIES 18 SPARE ELEMENT STYLE NUMBER (8.25kV)			
CONTROL VOLTAGE		DST-2VR500 8.25kV, 1200A	DST-2VR500 8.25kV, 2000A
CLOSE & MOTOR	TRIP	ELEMENT STYLE	ELEMENT STYLE
48 VDC	48 VDC	3A74508G01	3A74509G01
125 VDC	125 VDC	3A74508G02	3A74509G02
250 VDC	250 VDC	3A74508G03	3A74509G03
120 VAC	48 VDC	3A74508G04	3A74509G04
240 VAC	48 VDC	3A74508G05	3A74509G05
120 VAC	CAP (120V)	3A74508G06	3A74509G06
240 VAC	CAP (240V)	3A74508G07	3A74509G07

VCP-WR SERIES 18 SPARE ELEMENT STYLE NUMBER (15kV)					
CONTROL VOLTAGE		DST-2VR500 15kV, 1200A	DST-2VR500 15kV, 2000A	DST-2VR750 15kV, 1200A	DST-2VR750 15kV, 2000A
CLOSE & MOTOR	TRIP	ELEMENT STYLE	ELEMENT STYLE	ELEMENT STYLE	ELEMENT STYLE
48 VDC	48 VDC	3A74511G01	3A74512G01	3A74514G01	3A74515G01
125 VDC	125 VDC	3A74511G02	3A74512G02	3A74514G02	3A74515G02
250 VDC	250 VDC	3A74511G03	3A74512G03	3A74514G03	3A74515G03
120 VAC	48 VDC	3A74511G04	3A74512G04	3A74514G04	3A74515G04
240 VAC	48 VDC	3A74511G05	3A74512G05	3A74514G05	3A74515G05
120 VAC	CAP (120V)	3A74511G06	3A74512G06	3A74514G06	3A74515G06
240 VAC	CAP (240V)	3A74511G07	3A74512G07	3A74514G07	3A74515G07

VCP-WR SERIES 18 SPARE INTERRUPTER ASSEMBLY (POLE UNIT) STYLE NUMBER					
RATED AMPERAGE	DST- 2VR250 4.76kV	DST- 2VR350 4.76kV	DST-2VR500 8.25kV	DST- 2VR500 15kV	DST- 2VR750 15kV
1200 Amp.	3A73923H01	3A73932H01	3A73925H01	3A73928H01	3A73930H01
2000 Amp.	3A73924H01	3A73933H01	3A73926H01	3A73929H01	3A73931H01

CUTLER-HAMMER ENGINEERING SERVICE OFFICES

ALABAMA

Cutler-Hammer
1920 Seattle Slew Dr.
Helena, AL 35080
205/621-6440

Cutler-Hammer
1001 Yeager Parkway
Pelham, AL 35124
205/621-6401

ARIZONA

Cutler-Hammer
2415 W. Huntington Dr. St 101
Tempe, AZ 85282
602/414-5312

CALIFORNIA

Cutler-Hammer
1343 E. Gene Autry Way
Anaheim, CA 92805
714/704-5920

Cutler-Hammer
11770 Bernardo Plaza Ct, St 366
San Diego, CA 92128
619/613-2816

Cutler-Hammer
1555 Doolittle Dr. Suite 110
San Leandro, CA 94577
510/614-7990

COLORADO

Cutler-Hammer
1610 West Tuffs
Littleton, CO 80110
303/470-8280

FLORIDA

Cutler-Hammer
2151 W. Hillsboro Blvd, St 300
Deerfield Beach, FL 33442
954/481-8509

GEORGIA

Cutler-Hammer
9000 Central Park Rd, St 200
Atlanta, GA 30328
770/671-2630

ILLINOIS

Cutler-Hammer
104 E. Chestnut Ave.
Westmont, IL 60559
630/325-6780

INDIANA

Cutler-Hammer
7998 Georgetown Rd, St 400
Indianapolis, IN 46268
317/704-2520

KANSAS

Cutler-Hammer
1796 Kansas City Rd.
Olathe, KS 66061
913/390-0628

KENTUCKY

Cutler-Hammer
1230 Liberty Bank Lane
Louisville, KY 40222
205/621-6401

LOUISIANA

Cutler-Hammer
11568 Merchantile Dr.
Baton Rouge, LA 70809
504/756-1622

MAINE

Cutler-Hammer
RR #3, 910 F
Winthrop, ME 04364
207/377-5742

MARYLAND

Cutler-Hammer
6671 Santa Barbara Ct.
Elkridge, MD 21075
410/379-0157

MASSACHUSETTS

Cutler-Hammer
113 Cedar St, St S1
Milford, MA 01757
508/634-7600

MICHIGAN

Cutler-Hammer
26201 Northwestern Hwy.
Southfield, MI 48076
248/356-2193

MINNESOTA

Cutler-Hammer
5421 Feltl Rd. Suite 190
Minnetonka, MN 55343
612/912-1330

MISSOURI

Cutler-Hammer
2043 Woodland Parkway, St 100
St. Louis, MO 63146
314/812-2810

NEW JERSEY

Cutler-Hammer
379 Thornall St., 8th Floor
Edison, NJ 08837
732/205-2615

NEW YORK

Cutler-Hammer
495 Commerce Drive
Amherst, NY 14228
716/691-4333

NORTH CAROLINA

Cutler-Hammer
5540 Centerview Dr., St 318
Raleigh, NC 27606
919/852-2520

OHIO

Cutler-Hammer
4711 Hinckley Industrial Pkwy.
Cleveland, OH 44109
502/645-0352

Cutler-Hammer
8930 Beckett Rd.
West Chester, OH 45069
513/387-2033

OREGON

Cutler-Hammer
6024 SW Jean Rd. Bldg. C8
Lake Oswego, OR 97035
503/636-8333

PENNSYLVANIA

Cutler-Hammer
150 Radnor-Chester Rd.
Suite 320, Bldg. A
St. Davids, PA 19087
610/293-2350

Cutler-Hammer
130 Commonwealth Drive
Warrendale, PA 15086
724/779-5800

SOUTH CAROLINA

Cutler-Hammer
310 Maxwell Ave.
Greenwood, SC 29646
864/223-6525

TEXAS

Cutler-Hammer
6006 N. Mesa # 328
El Paso, TX 79912
915/833-2255

Cutler-Hammer
1100 Avenue T
Grand Prairie, TX 75050
972/606-5933

Cutler-Hammer
8706 Meldrum St.
Houston, TX 77075
713/948-8235

UTAH

Cutler-Hammer
2550 S. Decker Lake Blvd #10
West Valley City, UT 84119
801/974-0415

VIRGINIA

Cutler-Hammer
8100 Three Chopt Rd. Suite 20
Richmond, VA 23229
804/285-2061

WASHINGTON

Cutler-Hammer
11317B NE 120th St.
Kirkland, WA 98034
425/814-0622

WEST VIRGINIA

Cutler-Hammer
1403 Johnson Avenue
Bridgeport, WV 26330
304/842-9007

WISCONSIN

Cutler-Hammer
2350 Pershing St. Suite C
Appleton, WI 54914
920/997-0350

CANADA

Cutler-Hammer
#6 2135 32nd Ave. NE
Calgary, Alberta
Canada T2E 6Z3
403/216-3950

Cutler-Hammer
10331 B 178th St.
Edmonton, Alberta
Canada T5S 1R5
403/444-0060

Cutler-Hammer
1A-315 McDonald Crescent
Ft. McMurray, Alberta T9H 4B7
403/790-0114

Cutler-Hammer
67 Chartersville Rd.
Dieppe, New Brunswick E1A 1K2
506/383-2903

Cutler-Hammer
259 Bayview Dr. Unit #2
Barrie, Ontario L4N 4Y8
705/735-9000

Cutler-Hammer

3228 South Service Rd.
Burlington, Ontario
Canada L7R 3Y8
905/631-4715

Cutler-Hammer
20 Steckle Place Unit 16
Kitchener, Ontario N2E 2C3
519/893-4848

Cutler-Hammer
30 Camelot Dr. Suite 500
Nepean, Ontario K2G 5X8

613/225-3325

Cutler-Hammer
1273 North Service Rd.
Oakville, Ontario L6H 1A7
905/815-0500

Cutler-Hammer
598 Falconbridge Rd. Unit 1A
Sudbury, Ontario P3A 5K6
705/524-7955

Cutler-Hammer
1275 rue Industrielle
LaPrairie, Quebec
Canada J5R 2E4

www.ElectricalPartManuals.com

www.ElectricalPartManuals.com

www.ElectricalPartManuals.com