

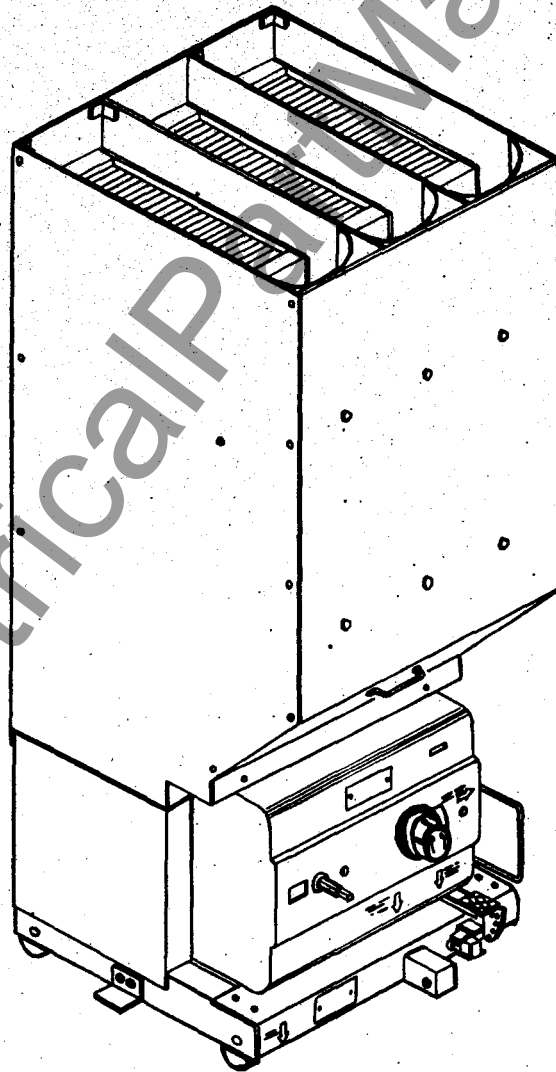

INSTRUCTION MANUAL

**TYPE DST-2 5KV & 15KV
MAGNETIC AIR CIRCUIT BREAKER
IN-820.11 DATED APRIL, 1972**



FEDERAL PACIFIC ELECTRIC COMPANY

150 AVENUE L, NEWARK, NEW JERSEY 07101

PRINTED IN U.S.A.

TABLE OF CONTENTS

PART I – GENERAL INFORMATION

1. Introduction	3
1.1 Foreword	3
1.2 General Description	4
1.3 Construction	4
1.4 Features	4
2. Shipping	4
3. Inspection	5
4. Storage Prior to Installation	5
5. Installation	5
5.1 Preliminary Operations	5
5.2 Safety Precautions	5
5.3 Mechanical Checking	5
5.4 Installation	5
5.4.1 Lifting	5
5.4.2 Arc-chute Fitting	5
5.5 Racking Operations	6
5.6 Manual Checking of Operating Mechanism	7
5.7 Electrical Checking of Operating Mechanism	7

PART II – GENERAL MAINTENANCE

6.1 Periodical Inspection	7
6.1.1 Arc-chute Inspection	7
6.1.2 Arcing Contact Inspection	7
6.1.3 Replacement and Adjustment of Arcing Contacts	7
6.1.4 Main Contact Inspection	8
6.1.5 Main Contact Replacement	8
6.2 Operating Mechanism Maintenance	9

PART III – DETAILED MAINTENANCE PROCEDURES

7. Operating Mechanism	9
7.1 Characteristics	9
7.2 Principles of Operation	9-11
7.2.1 Breaker Open—Closing Springs Discharged	9
7.2.2 Breaker Open—Closing Springs Charged	9
7.2.3 Breaker Closed with Closing Springs Discharged	11
7.2.4 Breaker Closed with Springs Charged	11
7.3 Trouble Shooting	11
7.3.1 The Breaker Cannot be Closed	11
7.3.2 Problem with the Spring Charging Motor or in the Chain	11
7.3.3 The Breaker Cannot be Opened Electrically	11-12
7.4 Checks and Adjustments	12
7.4.1 Adjustment of the Closing Spring Mechanical Lock	12
7.4.2 Checking the Trip Bar for Breaker Opening	12
7.4.3 Checking the Closing Release for Closing the Breaker	12
7.4.4 Adjustment of the Clearance between the Ratchet Pawl and the Sprocket Wheel to Prevent Overstressing the Pitch Chain	12

PART IV – APPENDIX

7.5 Fitting, Replacement and Adjustment of the Trip Latch	13
7.6 Replacement of the Closing Spring	13
7.7 Hydraulic Shock Absorber	13
7.8 Fitting the Operating Mechanism to the Breaker	14
8. Schedule of Maintenance	14
9. Operating Time & Contact Velocities	15
10. Control Power Requirements	15
11. Wiring Diagrams: AC close; DC close	16
12. Accessories	17-19
13. Spare Parts	19-23

Refer to IN-820.4A for metal-clad switchgear installation, operation and maintenance instructions.

PART I – General Information

1 INTRODUCTION

1.1 FOREWORD

Federal Pacific Electric Company apparatus is built to the highest standard of quality to insure continuous reliable service with a minimum of maintenance. Some routine preventative maintenance is, however, required on semi-annual or annual basis in accordance with the various uses of the product. It is suggested that, due to the precision craftsmanship involved in the construction of this apparatus, no attempts (with the exception of few minor adjustments) should be made by the customer to fix or adjust clearances.

Should the need occur, the Field Service Department of the Power Equipment Systems Division of Federal Pacific Electric Company is equipped to assist you with any maintenance or repair which may be required throughout the anticipated long life of this equipment.

FPE "On-Site Test Facilities" are available to you. This service includes engineering inspection and testing of electrical equipment planned to supplement your regular maintenance program, to improve equipment reliability and to protect your investment. Such services, for Metal Enclosed,

Metal Clad Switchgear, and other type Electrical Apparatus are as follows:

- (a) Cleaning of cells with low pressure air or vacuum.
- (b) Inspection of cell bushings, cable connections and bus joint connections.
- (c) General inspection of control wiring and components.
- (d) 2500 Volt DC Megger Tests and DC Hi-pot Tests for Insulation Reliability.
- (e) Protective Relay Calibration Tests for Response and Time Delay.
- (f) 5KV and 15KV circuit breaker electrical and mechanical operating checks coordinated with relay response.
- (g) Transformer oil or askarel dielectric Hi-pot Tests (also on minimum oil breakers and tank type oil breakers).

For further information regarding service, please contact the Manager of Field Service Department at Newark, New Jersey.

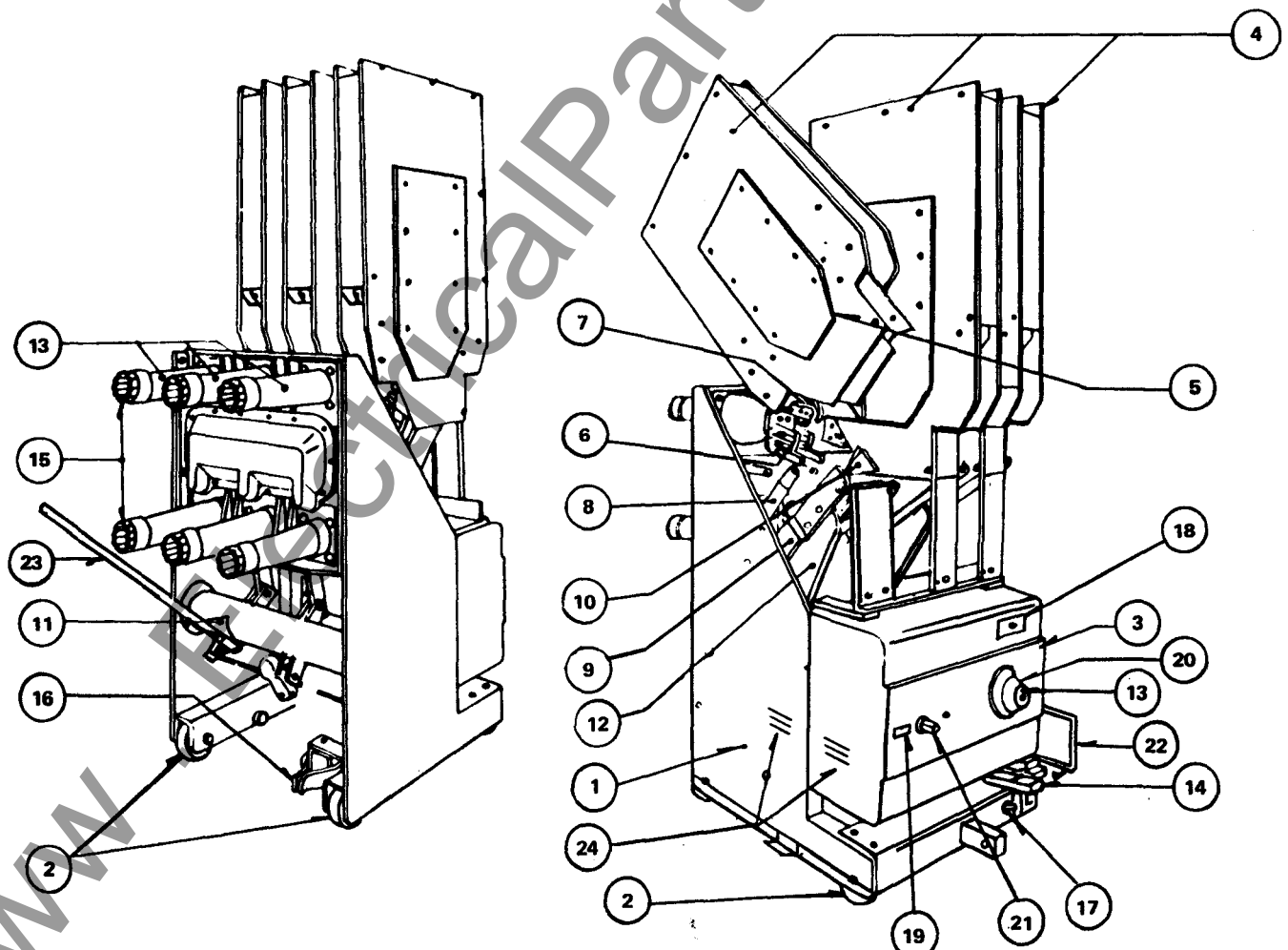

5kV 75, 150 and 250 MVA CIRCUIT BREAKER
Figure 1

1.2 GENERAL DESCRIPTION (Figure 1)

The DST-2 Magnetic Air Circuit Breaker is electrically operated, horizontal drawout for use in indoor and outdoor metal-clad switchgear.

It is designed for international application and service; therefore, the dimensional data is given in both the metric and English systems. The hardware is based on the metric system.

It is composed of three separate poles supported by a welded steel frame (1) and provided with wheels (2) so it can be easily moved in and out of its cell.

Each pole consists of two separate parts:

(a) Arc-chute (4) – is a chamber filled with ceramic baffles. It has a magnetic structure that forces the arc into constrictions provided by the baffling. The magnetic field is generated by coils (5) within the arc chute. Cooling and elongation of the arc within the baffle structure forces quick extinction of the arc.

(b) Contact unit – is made up of the main contacts, fixed (6) and moving (9) and the arcing contacts, fixed (7) and moving (10).

The main contacts, of silver plated copper, carry the normal service current. They are not affected by the interruption since they open before the arcing contacts separate.

The fixed and moving arcing contacts are made with tungsten-copper arc resistant inlays and are capable of interrupting high short circuit current without damage.

The puffer nozzles (8) are located under the fixed contacts. The moving contact group is operated by the shaft (11), through insulated links (12). The metal frame is grounded through the ground contacts (16).

A welded sheet steel front barrier is grounded thus assuring safety to operating personnel. The contact structures are separated by insulated interphase barriers.

The breaker can be either manually operated by means of a knob (13) or remotely operated.

The motor charged spring closing mechanism (3) is especially designed for medium voltage circuit breakers. It is completely enclosed for safety and dirt exclusion.

1.3 CONSTRUCTION

The DST-2 is a drawout type breaker. It is built to allow ease of maintenance and operation. The breaker is available complete with cell or for insertion into a metal-clad breaker cell. The breaker can be positioned as follows:

1. "Connected" position – where primary and secondary disconnects are automatically connected.
2. "Test" position ("Isolated" position) – where primary disconnects are disconnected and secondary disconnects can be manually connected or disconnected.
3. Removed from the cell by operating the "racking in" lever. It is provided with a pedal operated interlocking device (14).

The circuit breaker is fitted with spring loaded, self aligning primary disconnects which engage the stationary studs mounted in insulating bushings in the cell (15).

When the breaker is in "Test Position" or drawn out of the cell, the cell shutter, operated by racking action of the

breaker, covers the live parts providing protection to personnel.

1.4 DST-2 FEATURES (Fig. 1 unless otherwise noted)

All breakers are equipped with the following parts and provisions.

- (1) Arc-chutes (4)
- (2) Barrier (1, Fig. 2)
- (3) 5 Unit auxiliary switch with 2"a" and 2"b" extra contacts (1, Fig. 5). Other types available upon request.
- (4) Lockout switch. (Blocks closing and motor circuits) (17)
- (5) Latch check switch (2, Fig. 5)
- (6) Mechanical operation counter (counts trip operations) (18)
- (7) "Y" relay (5, Fig. 5)
- (8) TC trip solenoid and 52X close solenoid (3, Fig. 5)
- (9) Charging motor (4, Fig. 5)
- (10) Mechanical indication of "Charged" and "Discharged"
- (11) Mechanical indication of "Open" and "Closed" (20)
- (12) Mechanical indication of "Charged" and "Discharged" (19)
- (13) Mechanical drawout interlock (prevents movement of breaker in or out of cell with contacts closed) (14)
- (14) Mechanical interlock discharges closing spring when inserting or removing breaker from cell.
- (15) Padlock provision. (Lock breaker tripped with pedal down or lock to prevent racking in or out with pedal up. (14)
- (16) Provision for manual charging of springs (21)
- (17) Manual trip – close control knob (13)
- (18) Automatic Secondary contacts in "Connected" position (22)
- (19) Manually operated secondary contacts in "Test" position.
- (20) Mechanism is mechanically and electrically trip free.

2 SHIPPING

All circuit breakers are assembled and tested for optimum performance in the factory before shipment. The 5kV 250 MVA circuit breaker is shipped completely assembled in one crate. The 5kV 350 MVA and 15kV circuit breakers are shipped in two crates. The basic circuit breaker on its truck with interphase barrier is in one crate. The three arc chutes are packed in a second crate.

The serial number of each circuit breaker is on its nameplate. It is also stenciled on both breaker frame and operating mechanism frame as indicated in (24, Fig. 1). The crates are marked with the factory order number.

A copy of the packing list, enclosed in a waterproof envelope is nailed on the outside of the circuit breaker crate. Only one envelope is furnished with orders for more than one circuit breaker shipped to a single destination.

Each circuit breaker, in its crate, is enclosed in a polyethylene dust-and-moisture-proof bag.

3 INSPECTION UPON RECEIPT OF SHIPMENT

When a shipment of circuit breakers is received, each crate should be examined before it is removed from the railroad car or truck. If any damage or indication of rough handling is evident, a description of the condition should be written on the freight bill, a claim should be filed against the carrier immediately, and notice of the extent of damage sent without delay to Federal Pacific Electric Co. at the address from which shipment was made, giving serial number of the breaker, the carrier's name, and the car number if shipped by rail. This information enables the company to supply needed information to assist the purchaser in support of the claim. (See 6.1.1)

4 STORAGE PRIOR TO INSTALLATION

A breaker can be safely stored provided that the following instructions are observed:

- Handle the breaker with the utmost care, lift circuit breaker less arc chutes using a hoist or similar means and attach the sling hooks to the holes on the sides of the breaker. The 5 and 15kV circuit breakers with arc chutes are lifted by fitting the sling under the wheel channels and securing top to prevent tipping.
- Upon receipt of the breaker an inspection should be made. The circuit breaker should be stored, "Opened" and "Discharged", in its original shipping container. The 15kV and 5kV 350 arc chutes should be stored in the original shipping crate.
- Keep the breakers in a dry place, protected against dust and chemical agents, preferably in cells with cell or auxiliary heaters energized.

5 INSTALLATION

5.1 PRELIMINARY OPERATIONS

Before setting a breaker into operation, the following operations should be carried out:

- Carefully clean all parts of the breaker with a dry cloth.
- Check the condition of contacts and terminals. The main contacts are coated with a thin layer of contact lubricant. If the main contacts are dirty they should be cleaned with acetone and sparingly relubricated with FPE #1551 A 5853 contact grease. The terminals and arcing contacts should be cleaned with acetone. The three moving arcing contacts must close and open simultaneously. See section 6.1.3, Page 7 for adjustment specification.

Tighten all the parts listed in Appendix 8 under "Maintenance to be carried out."

5.2 SAFETY PRECAUTIONS

The following checks should be made before putting a breaker into service.

- Check the alignment between the ground contact (16, Fig. 1) and the grounding blade located on the cell floor.
- Insure that the arc chutes are properly connected.
- Check the main and secondary electrical connections.
- Never rack the breaker into the "Operate" position without the arc chutes and interphase barriers properly installed.

5.3 MECHANICAL CHECKING

Each circuit breaker is carefully inspected and operated at the plant before shipment; yet it is advisable to carry out some closing and opening operations before putting a breaker into service. For detailed inspection remove arc chutes and interphase barriers and follow the instructions for "Manual Checking of Operating Mechanism" (Section 5.6).

5.4 INSTALLATION

5.4.1 Lifting

Lifting is to be done as described in Section 4 (a). Handle the breaker with the utmost care, lift it using a hoist or similar means. Inspect for breakage. (See 6.1.1)

5.4.2 Arc chute Fitting (Fig. 2)

5kV 350 and 15kV Arc Chute Mounting

Arc chutes are shipped separately from circuit breaker and must be mounted before installation. Arc chute return connection and arc chute must be positioned as follows:

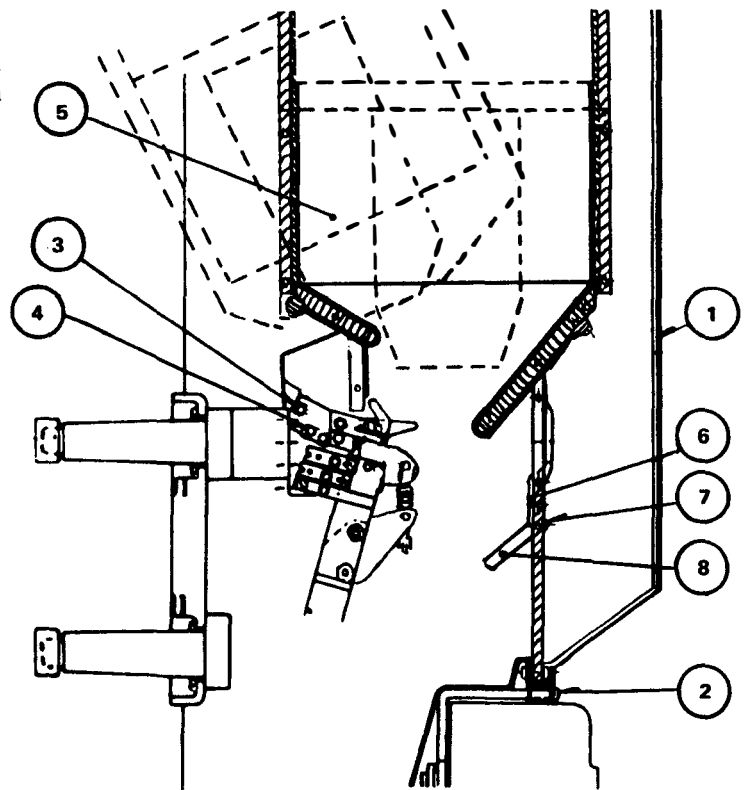

5kV 75, 150 AND 250 MVA
Figure 2a

It is imperative that arc chute return connection is securely against arc chute support plate. Check that both nuts are tight affording a good electrical connection.

Before fitting the arc chutes on the 15kV circuit breaker or 5kV 350, make sure there is no foreign matter inside them. Then:

- (a) Remove screws (2) and remove the interphase barrier (1).
- (b) Lift arc chute with lifting yoke (Page 18) and fit the conductor pin (3) into saddles (4). Arc chute lifting station is provided in aisle units.
- (c) Rotate the arc chute downwards until plates (6) are fitted to stud (7).
- (d) Fix the arc chute by means of nuts on studs (7), making sure that the connector (8) is assembled outside of the plates (6). See Fig. 2b and 2c.

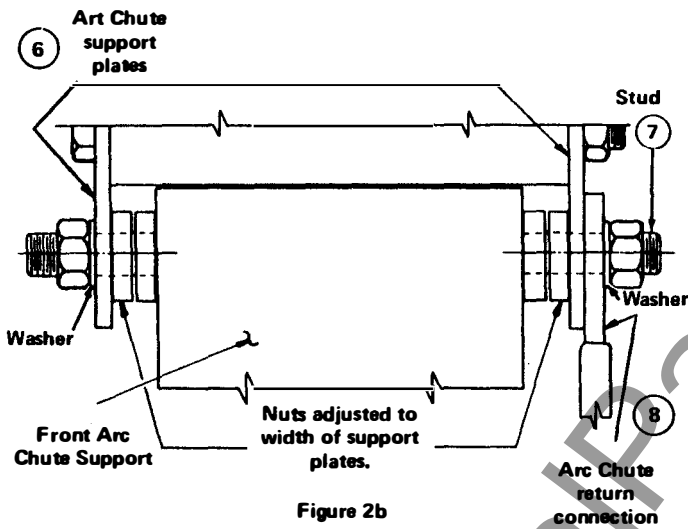

Figure 2b

5kV, 75, 150 and 250 Arc Chute Mounting

Arc chutes are shipped already assembled to circuit breaker. In the event of arc chute removal, the arc chute return connection and arc chute must be positioned as follows:

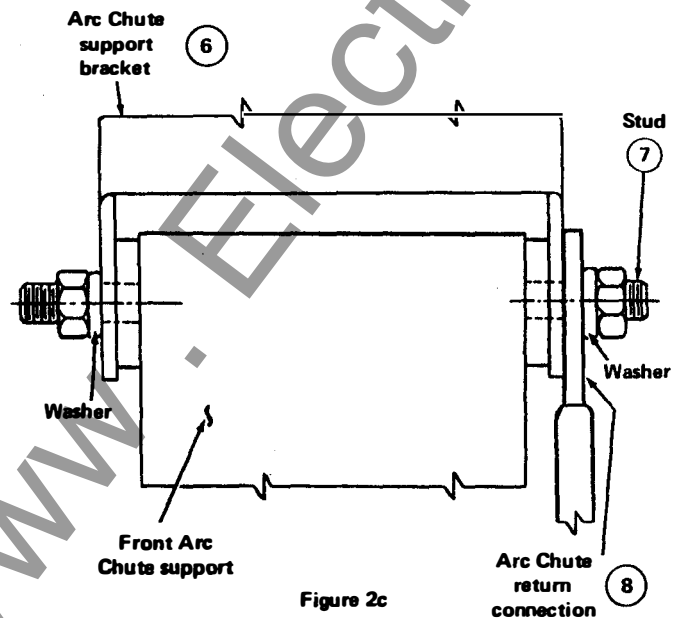

Figure 2c

It is imperative that the arc chute return connection is securely against arc chute support bracket. Check that both nuts are tight affording a good electrical connection.

5.5 RACKING OPERATIONS (Fig. 3a, 3b, 3c)

- (a) Roll the breaker on the rails using handling dolly and check that it moves freely.
- (b) Move the breaker to the "Test" position using the racking lever, as shown in Figure 3a. Shift lever back and forth until you hear the clicking sound of the lock engaging the interlock rail. Lockout switch, (3), must be reset if operating circuit breaker in "Test" position is desired.
- (c) To continue racking, repeat the preceding operations after releasing the interlock bar (1) by pressing the pedal (2). Trip the circuit breaker before pressing the interlock pedal. Reset the lockout switch each time after pressing interlock pedal to permit electrical operation.
- (d) To rack the breaker out; place the lever as shown in Fig. 3b and perform the same operations as above.

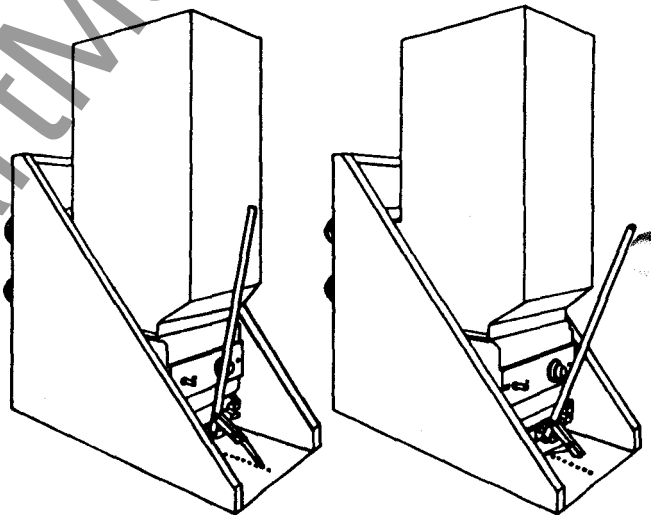

Figure 3a

Figure 3b

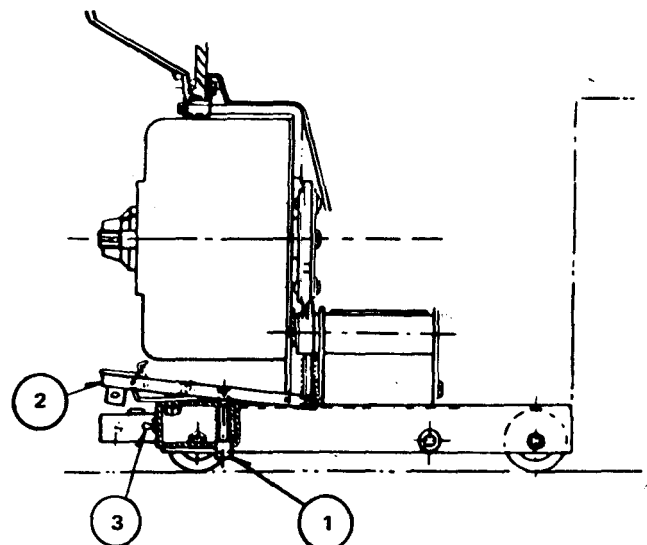

Figure 3c

5.6 MANUAL CHECKING OF OPERATING MECHANISM (Circuit Breaker Out of Cell)

Charge the closing springs by means of manual charging handle, then close and trip the breaker manually. Check mechanical operation of the mechanism. The breaker should operate smoothly and freely without any indication of binding.

Check that the control voltage agrees with the breaker nameplate and is within the limits specified in Appendix 10.

It is suggested that several mechanical closing and opening operations be performed.

5.7 CHECKING ELECTRICAL OPERATION OF MECHANISM

The circuit breaker may be electrically operated safely in the cell in the "Test" position. Move the breaker in the cell until the interlock bar drops into the first notch. This is the "Test" position. The shutter should remain down isolating the breaker from the high voltage bus. The secondary circuit is completed by manually pushing the secondary contact operating handle (right side of breaker frame) all the way in (22, Fig. 1). Reset the lockout switch (17, Fig. 1) by lifting the toggle handle. Close and trip the breaker several times from the control switch. After each closing operation the motor will recharge the closing springs.

PART II – General Maintenance

6.1 PERIODIC INSPECTION

A schedule for maintenance of a breaker in service is included in Appendix No. 8. In addition to the listed operation it is recommended to carefully clean the breaker at least every six months.

The contacts and arc chutes should be frequently and carefully inspected, as instructed in 6.1.1 – 6.1.5, if the breaker has been subjected to frequent operations on short circuits or overload.

The breaker, and in particular the operating mechanism, should be frequently inspected if the breaker has been subjected to dust or corrosive industrial atmospheres.

6.1.1 Arc Chute Inspection (Figure 2)

Draw the breaker out, remove the safety barrier (1) as instructed in 5.4.2, loosen the nuts of studs (7), rotate the arc chutes approximately 45° backward one at a time by rotating around pins (3) then check the conditions of the arc chute plates.

If any breakages or flaws on arc chutes or ceramic plates or burning on blow-out coils are found, it is advisable to replace the arc chute. Replacement arc chutes may be ordered direct from the factory, by contacting Switchgear Marketing, Newark, New Jersey.

6.1.2 Arcing Contact Inspection

Draw the breaker out, remove the interphase barrier and arc chutes.

The arcing contacts should be reasonably clean, without pits and deformations. Small pits can be filed without modifying the shape of the contacts. In normal use, when currents of approximately the rated value are being interrupted, the arcing contacts might be slightly worn; replacement, however, is unnecessary.

In more severe service when appreciable wear is noticed, the arcing contacts should be replaced as described in 6.1.3.

Appendix No. 8 indicates the maximum number of operations the breaker should be expected to perform without replacement of the contacts.

6.1.3 Replacement and Adjusting of Arcing Contact (Figure 4)

Draw the breaker out, remove the interphase barrier and arc chutes (Fig. 2). Replace the arcing contacts as follows:

- (a) Open the breaker and discharge the closing springs.
- (b) 5kV 250, 350 and 15kV 750 MVA – Remove nut from contact pivot pin and remove pin. Remove spring pin retainer and spring pin. Remove 2 shunt screws and remove moving arcing contact. Install new contact in reverse procedure.
15kV 500 – Remove 3 studs securing moving arcing contact to the blades. Install new contact making certain that nuts are securely tightened.
- (c) Remove stationary arcing contact springs (5) (Fig. 4b and 4c) by removing adjusting nuts and stud. Remove upper shunt screw. Remove arcing contact assembly, remount shunt onto new arcing contacts and install in reverse procedure.
- (d) Adjust the moving arcing contact, making sure that all 3 poles close simultaneously and fixed to moving main contact gap as arcing contacts touch: 5kV 250 = 8 ± 1 mm (.32 \pm .04 in.); 5kV 350 = 4 ± 1 mm (.160 \pm .04 in.); 15 kV = 11 ± 1 mm (.44 \pm .04 in.). Contacts may be slowly closed using the maintenance bar (23, Fig. 1) for the 5kV breaker, and "Maintenance Close Device" (Page 19) for the 15kV breaker.
- (e) Close the breaker (Fig. 4c) and adjust the length of springs (5) to 11mm (.44 inch) for 15kV 500 and 14.5mm (.57 inch) for other ratings.
- (f) Open and close the breaker several times to check mechanical operation.
- (g) Remount the arc chutes and the interphase barrier as instructed in 5.4.2.

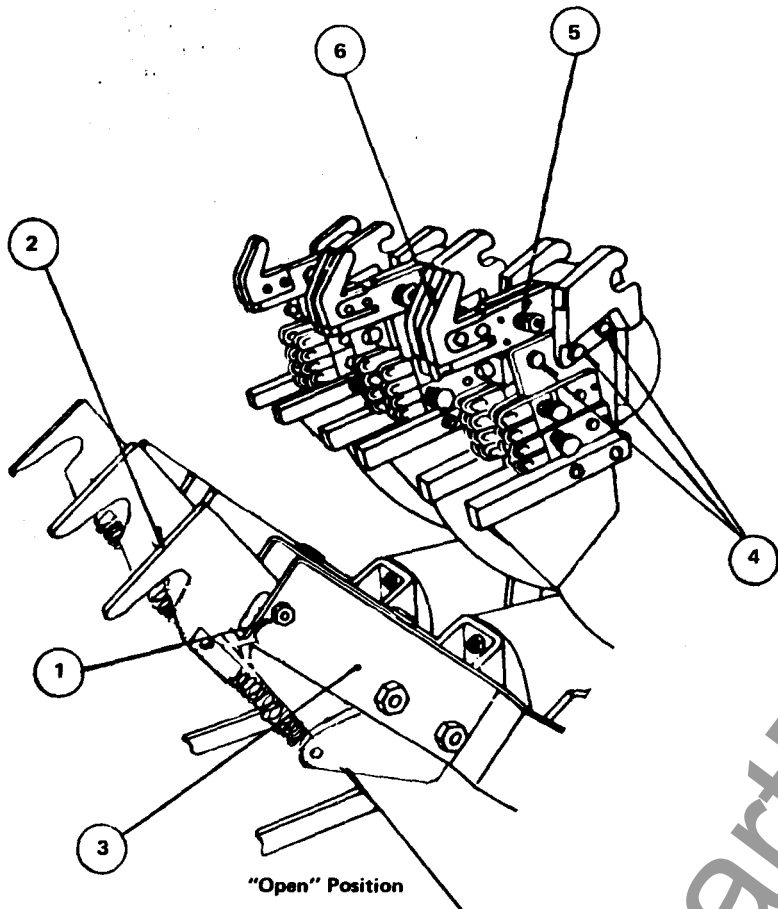

"Open" Position

Figure 4a

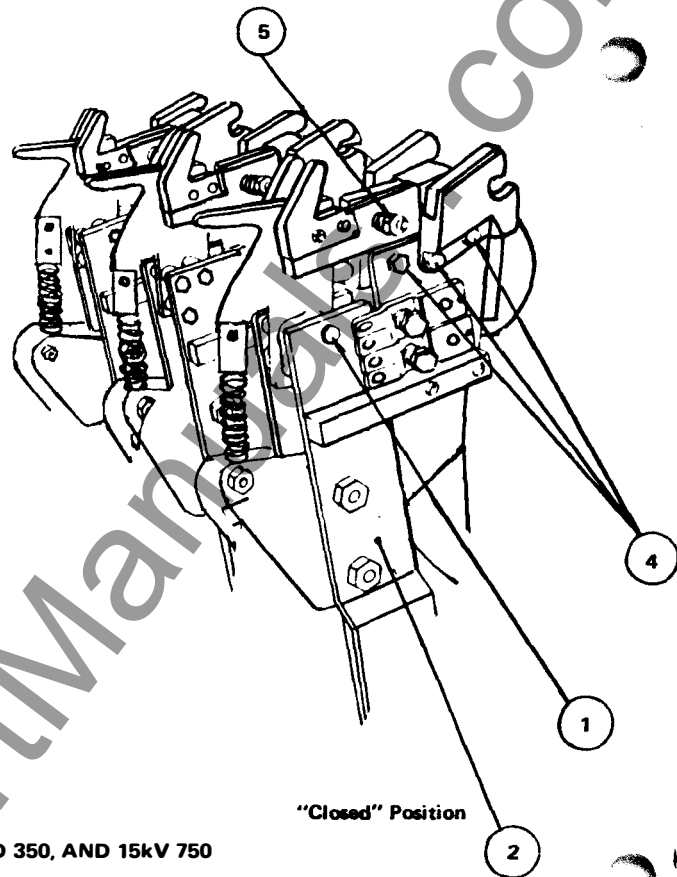

"Closed" Position

Figure 4b

5kV 75, 150, 250 AND 350, AND 15kV 750

6.1.4 Main Contact Inspection

Draw the breaker out, remove the interphase barrier, and tilt the arc chute back approximately 45° one at a time. Inspect the main contacts making sure they are in good condition and see that the face of the contact is coated lightly with FPE #1551 A 5853 Contact Lubricant. Use only minute quantity. Since these contacts do not break any current they should not be pitted or burnt.

(See Appendix 8 for the number of operations the main contact can withstand before replacement is necessary.)

15kV 500 MVA

11 ± 0.5mm
(.43 ± .02 in.)

All other ratings:
14.5 ± 0.5mm
(.57 ± .020 in.)

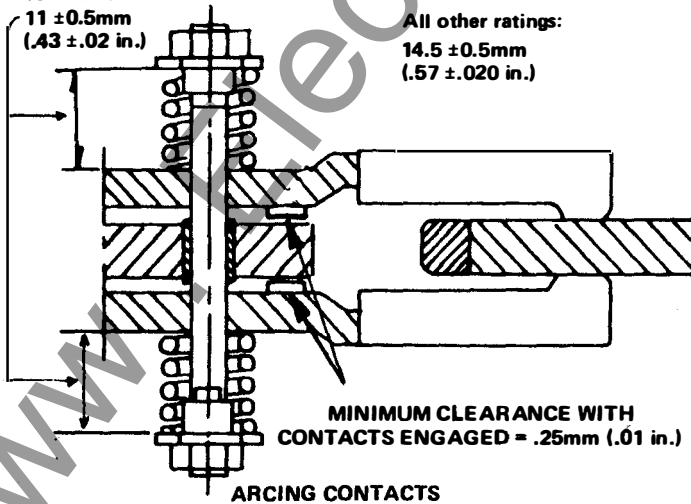

MINIMUM CLEARANCE WITH CONTACTS ENGAGED = .25mm (.01 in.)

ARCING CONTACTS

Figure 4c

6.1.5 Main Contact Replacing

Draw the breaker out, remove the interphase barrier and arc chutes. Replace the main contacts as follows: (Fig. 4d)

- Open the breaker and discharge the closing springs.
- Remove the spring by unscrewing the locknut and removing the adjusting screw. Remove main contact. Install new contacts in reverse procedure. NOTE: New self locking nut should be used.
- Adjust the main contact springs so that the length is 10 ± 2mm (.40 ± .008 in.) when the contacts are closed.

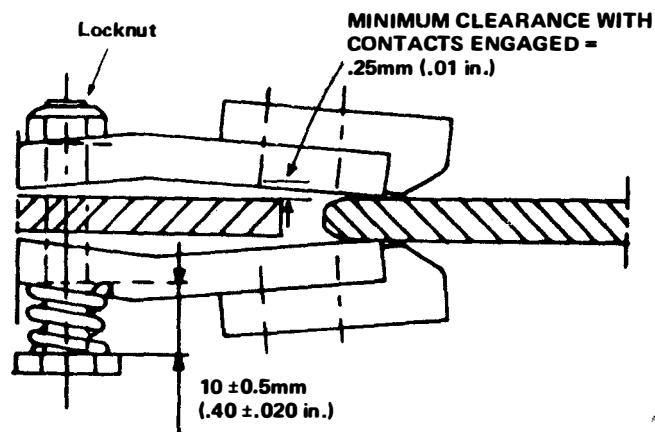

MINIMUM CLEARANCE WITH CONTACTS ENGAGED = .25mm (.01 in.)

10 ± 0.5mm
(.40 ± .020 in.)

MAIN CONTACTS

Figure 4d

To check contact alignment, use maintenance close handles (see Accessories Section).

Primary Disconnect Inspection

Check primary disconnect fingers to assure that they are positioned in a circle, not bent, and clean of residue.

Secondary Disconnect Inspection

Check molded contact assembly and moving carriage assembly to assure they they are not damaged and that the contact pins are not bent.

6.2 OPERATING MECHANISM MAINTENANCE

(Figure 9a and 9b)

The operating mechanism is supplied thoroughly lubricated and does not need any special care during its lifetime. It is, however, advisable to clean it carefully after every 2000 operations or once a year, whichever comes first.

The cleaning should be done by means of a paint brush drenched with acetone or other similar solvent with the breaker "Open" and springs "Discharged".

The links, levers, pins and chain drive mechanism should be lubricated with good quality light grease SAE Grade 1.

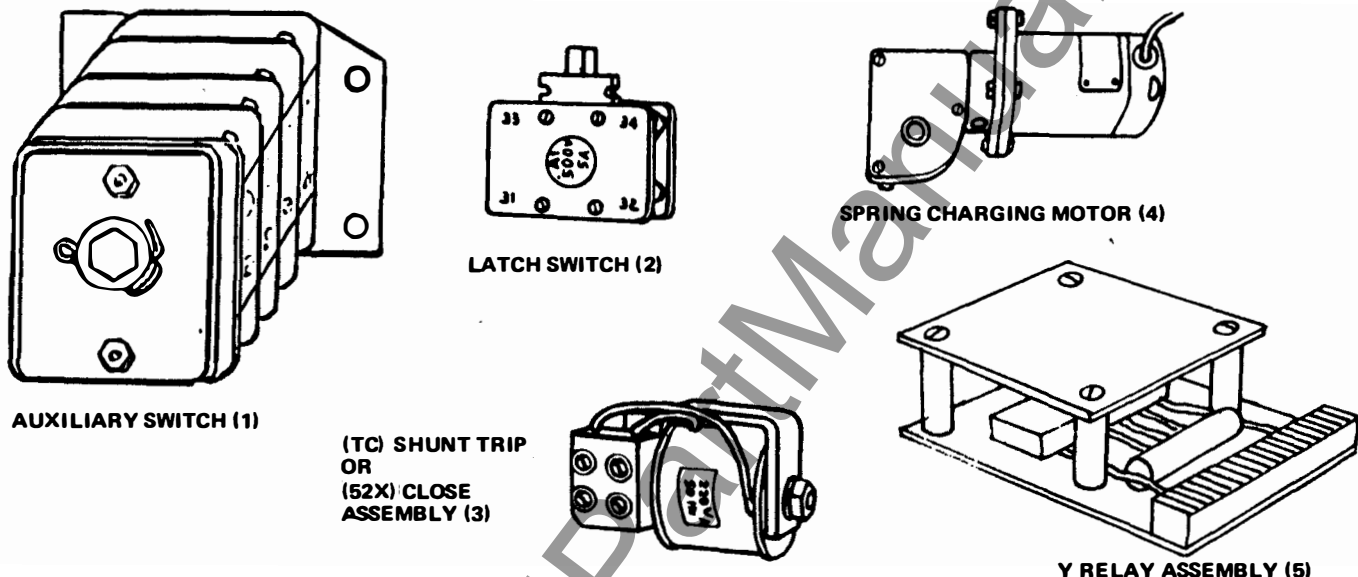

Figure 5

PART III — Detailed Maintenance Procedure

7 OPERATING MECHANISM (TYPE "AEM")

7.1 CHARACTERISTICS

The closing springs of the operating mechanism are charged by the motor. The spring charging time is approximately 10 seconds.

The mechanism performs the following cycles:

(a) Starting with the breaker open and springs charged:
CO → TC → CO → TC → CO

Where: CO is a "Close-Open" operation
TC is the Spring charging time

(b) Starting with the breaker closed and springs charged:
O → t → CO → TC → CO

Where: O is an "Open" operation
t is the reset time

7.2 PRINCIPLES OF OPERATION

The operating positions of the mechanism are described and shown in the following pages.

7.2.1 Breaker Open—Closing Springs (1) Discharged (Figure 6a)

The breaker is in this position after each "Close-Open" cycle before recharging. This is a transient position.

7.2.2 Breaker Open — Closing Springs (1) Charged (Figure 6b)

This is the usual operating position of the open breaker. The springs can be charged as follows: (Fig. 6a).

(a) Manual Charging.

Turn the shaft (3) half a turn clockwise using the crank (2). This corresponds to complete charging of the springs. When the shaft (3) is rotated, it drives the shaft (5) by means of the chain (4). The shaft, being connected to lever (6) through connecting rod (7) and crank, (8) causes, in its turn, the charging of the springs.

BREAKER OPEN: CLOSING SPRINGS DISCHARGED

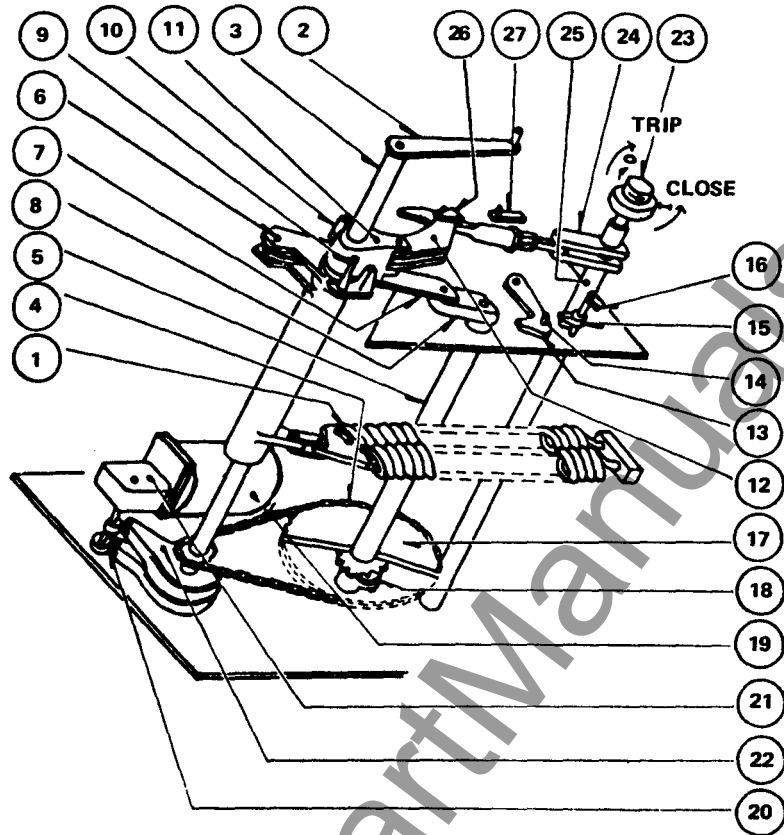

Figure 6a

BREAKER OPEN: CLOSING SPRINGS CHARGED

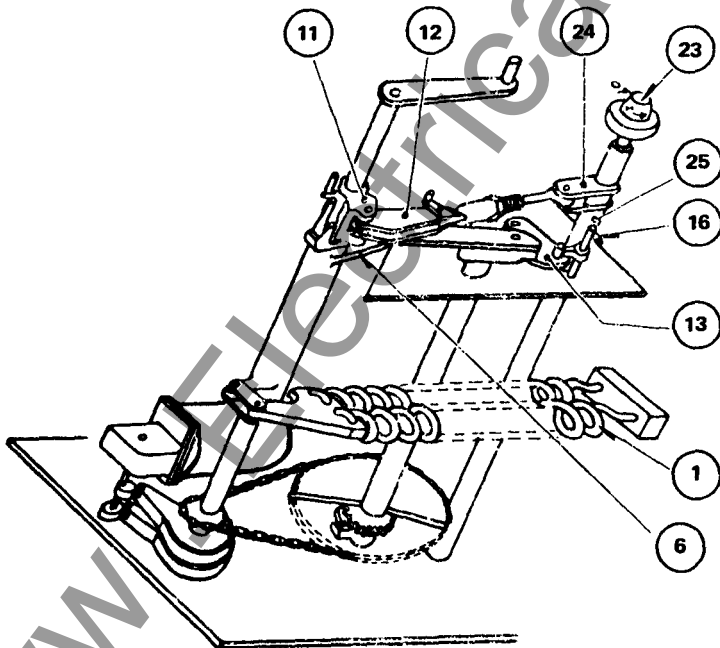

Figure 6b

BREAKER CLOSED: CLOSING SPRINGS CHARGED

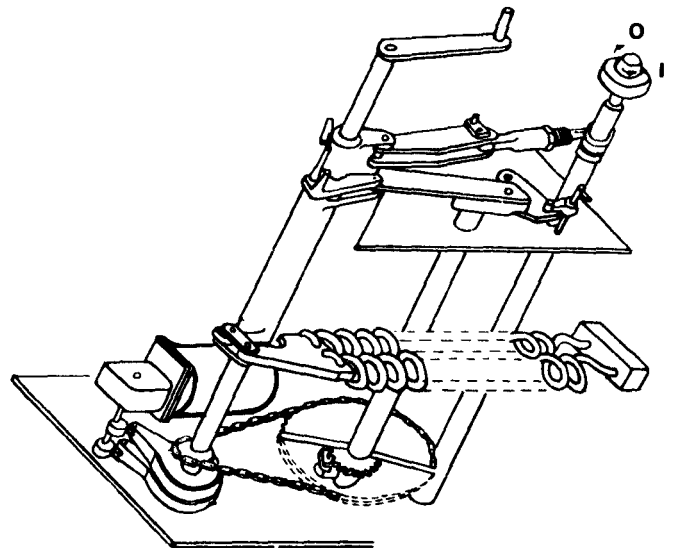

Figure 6d

BREAKER CLOSED: CLOSING SPRINGS DISCHARGED

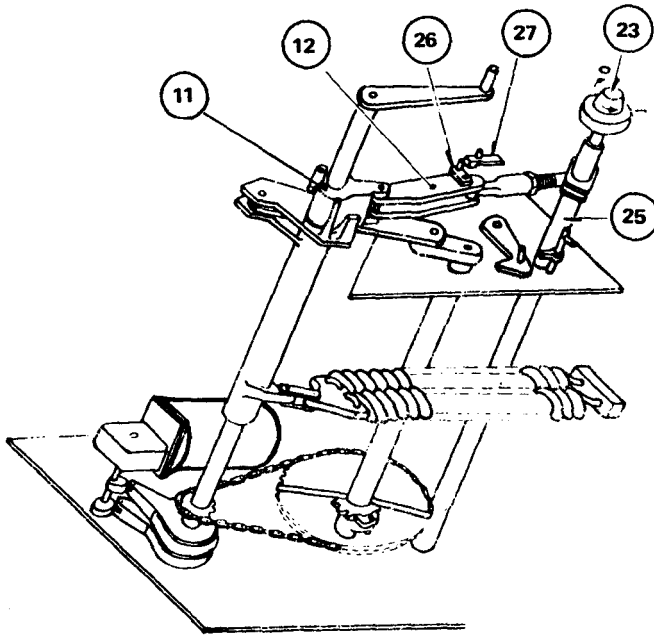

Figure 6c

At the end of this motion the trip latch assumes the latch position.

When fully charged, the primary closing latch (13) is held fixed by the secondary closing latch (15) on shaft (16) by means of bearing (14) assuring the springs are kept charged. The sprocket wheel (17) is then free from ratchet (18) and idles. The breaker will not close if springs (1) are not completely charged.

Although the spring charging can be done manually as described above, the usual procedure is to perform this operation by means of a motor.

(b) Motor Charging.

When motor (19) is energized, it rotates camshaft (20) through the reduction gear (21); the clutches (22) are actuated in such a way as to charge the springs in the same way it is done manually (see 6a).

If during the operation, the voltage supply fails, the motor is always in a position to continue charging once the power is restored. Charging can of course be continued manually, if necessary.

7.2.3 Breaker Closed with Closing Springs Discharged (Figure 6c)

This is a transient state for the breaker. It occurs whenever the breaker is closed and before the springs are recharged. The breaker mechanism is changed to this position as follows:

The shaft (16) is rotated either by the electrical close operation or manually with knob (23).

The latch (13) is released and springs (1) rotate the lever (6) counter-clockwise. This drives the shaft (25) clockwise through lever (11) and trip link and closes the breaker.

$3 + 0.5\text{mm}$
 $- .00\text{mm}$
(.118 + .02 in.)
 $- .00$ in.)

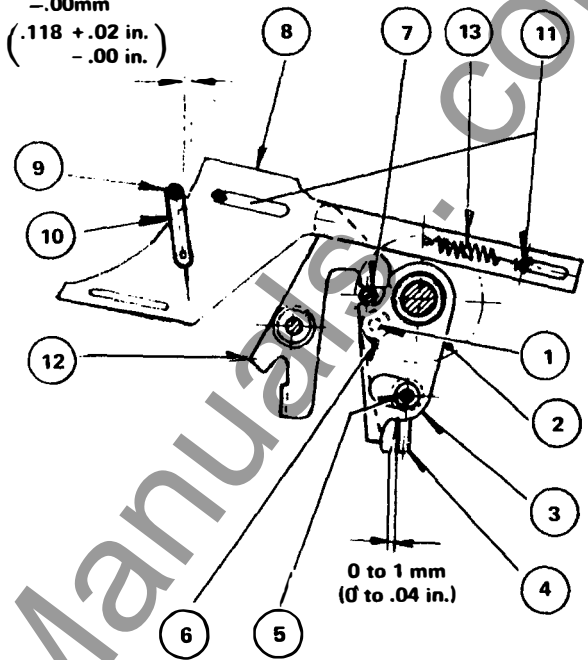

Figure 7

7.2.4 Breaker Closed with Springs Charged (Figure 6d)

This is the usual operating position of the closed breaker. The trip operation can be performed as follows:

- Manually, by rotating knob (23).
- Remote, through the shunt trip.

7.3 TROUBLE SHOOTING

7.3.1 When the Breaker Cannot be Closed

This may be due to the following:

- Looseness of the eccentric (6, Fig. 7) – adjust as instructed in 7.4.1.
- Warpage of the trip rod (8, Fig. 7) – check as instructed in 7.4.2.
- Wear of lever (7, Fig. 7, Page 10). – This trouble is very uncommon and may occur after a number of operations much greater than that recommended. The lever (7) is to be replaced at our plant or by an FPE Field Service Engineer.
- Clearance between the ratchet pawl (3, Fig. 8) and the sprocket wheel (4, Fig. 8) is different from the prescribed clearance. – See 7.4.4 for adjustment.

7.3.2 Problem with the Spring Charging Motor or in the Chain (16) (Figure 8)

This happens if the clearance between the ratchet pawl (3) and the sprocket wheel is incorrect. See 7.4.4 for adjustment.

7.3.3 The Breaker Cannot be Opened Electrically

This may be due to the auxiliary circuit not being closed.

Verify the circuits and their connection to the switchgear terminal blocks.

7.4 CHECKS AND ADJUSTMENT

7.4.1 Adjustment of the Closing Spring Mechanical Lock (Figure 7)

Since this adjustment is to be made with the breaker closed, the eccentric (6, Fig. 7) should first be locked by tightening screw (1) in such a way as to position the lobe opposite the pin (7); then, with the breaker closed and springs discharged, perform the following operations:

- Loosen screw (1) slightly.
- Turn knob (2) counter-clockwise until the clearance between the lever (3) and the pin (4) of trip bar (5) is between 0 and .04 inch (0 and .1 mm).
- Rotate the eccentric (6) until it is touching pin (7) of knob (2); lock it in this position by tightening the screw (1).

7.4.2 Checking the Trip Bar (8) for Opening the Breaker (Figure 7)

When the breaker is closed, the clearance between the pin (9) of the trip lever (10) and the trip rod (8) actuated by the knob (2) is to be 3 to 4mm (.12 to .16 in.). Should this clearance be less, the pin (9) would hit the trip bar (8) thus tripping the breaker.

Therefore, it is necessary to check that:

- The trip bar (8) is not warped and is not held upward by foreign matter.
- That the pins (11) are provided with washers and split rings.
- That the lever (12) is not warped and moves freely.
- That the spring (13) is fastened securely.

7.4.3 Checking the Closing Release (7) for Closing the Breaker (Figure 8)

With breaker open and springs discharged:

- Check for free movement of closing release bar (7) and make sure that when it is in the stop position, the right end of lever (6) is stopped by the slot (9) in the dividing plate.
- Roller (5) should engage lever (6) with a minimum overlap of 1.5mm (.06 inch).

7.4.4 Adjustment of the Clearance between the Ratchet Pawl (3) and the Sprocket Wheel (4) to prevent undue stresses to the Chain or to the Spring Charging Motor (Figure 8)

Starting from spring "Discharged" (1) position, rotate the shaft (2) half a turn clockwise, which corresponds to the full closing spring charging.

The ratchet pawl (3) must clear the sprocket wheel (4) at the instant when the bearing (5) presses against the upper part of lever (6) of closing release bar (7), thus assuring the spring "Charged" position.

If the ratchet pawl (3) clears the sprocket wheel (4) *before* the bearing (5) presses on the lever (6), the closing springs (1) are not completely charged and the breaker cannot be closed.

If, on the other hand, the ratchet pawl (3) clears the sprocket wheel (4) *after* the bearing (5) has pressed on the lever (6), the pitch chain (16) would be subjected to undue stresses and the motor would be excessively overloaded.

Therefore, with the springs in "Charged" position, the clearance between the ratchet pawl (3) and the sprocket wheel (4) must be $4 \pm .5\text{mm}$ (.16 \pm .02 inch). This is set by adjusting the eccentric (8) fixed to the base plate to get the clearance required.

The manual charge crank will override if an operator continues to charge after the mechanism is fully charged. This prevents possible damage to the mechanism.

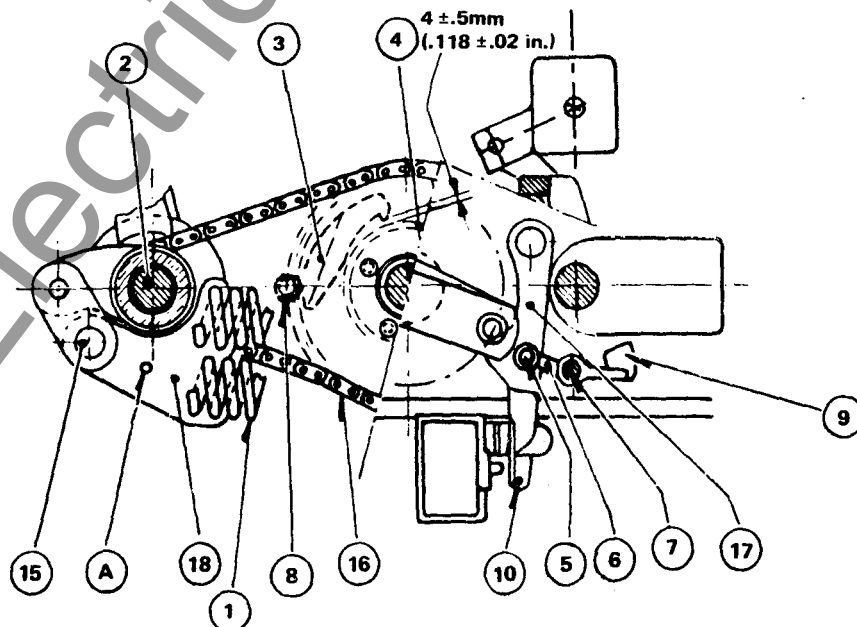

Figure 8

PART IV – Appendix

APPENDIX 7.5

Fitting, Replacement and Adjustment of the Trip Latch (Fig. 10).

- Open the breaker and discharge the springs.
- De-energize the auxiliary circuits.
- Charge the closing springs until the Trip Linkage system latches in the position shown, Fig. 10.
- Remove the split washer (2) and slip out the pin (3).
- Lift the lever (4) by operating on latch (5).
- Remove the clips and washers from pin (6).
- Disengage the trace reset springs (9).
- Remove the trace.

Adjustment of linkage length is made by screwing, in or out, of the right part into the left part of the assembly (item 7 and 8).

- Adjust the new assembly length (L) to equal the length of the one removed.
- To reassemble, reverse the above steps.

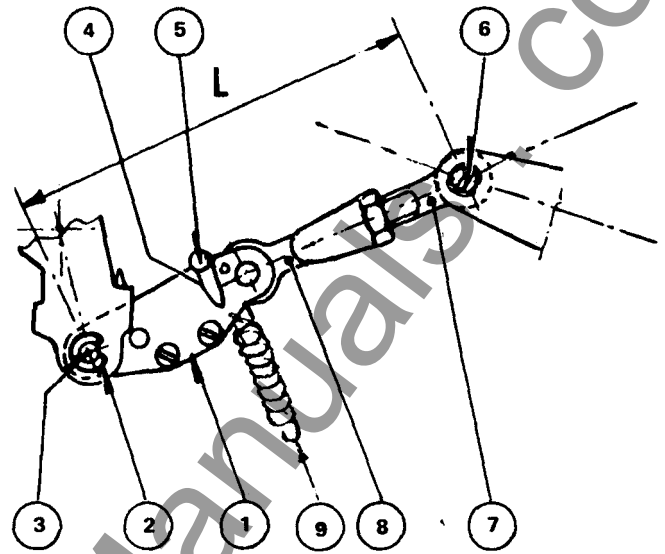

Figure 10

APPENDIX 7.6

(Type "AEM" Mechanism Only)

Replacement of Closing Springs (Fig. 8).

The closing springs can be fitted with the help of a hook (Fig. 11) which will be supplied on request, as follows:

- Insert a 5mm (.20 inch) dia. pin into hole (A) of closing spring support (18).
- Fit the hook to the pin and insert the threaded portion of the hook into the hole drilled in the left part of the operating mechanism housing.
- By means of the nut supplied with the hook, charge the springs until pin (15) can be fitted.
- Remove the hook and check the spring charging operation.

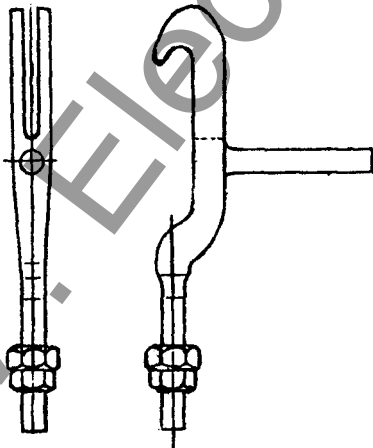

Figure 11

APPENDIX 7.7

Hydraulic Shock Absorber

Check Shock Absorber for any signs of leakage and for moving contact stopping without rebound.

An accurate check could only be made using a travel analyzer. Rebound is adjusted by shifting mounting brackets as shown.

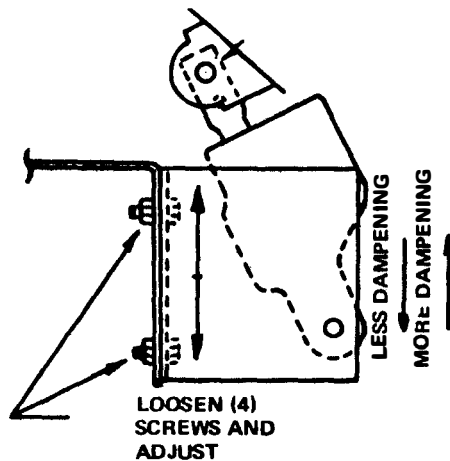

Figure 12a

5kV Except 5kV 350, 3000A

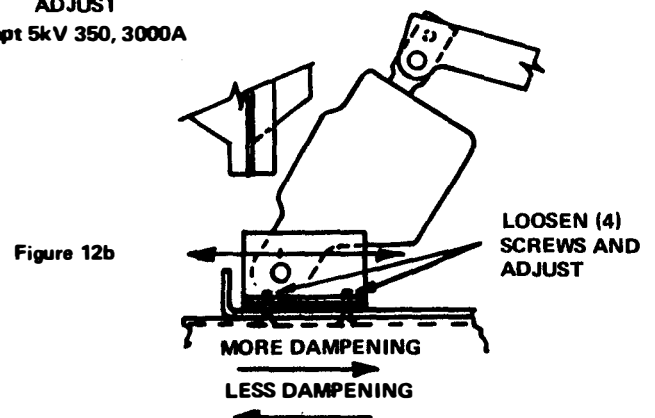

Figure 12b

5kV 350, 3000A and 15kV

APPENDIX 7.8

Fitting the Operating Mechanism to the Main Breaker.

The DST-2 is shipped as one unit with the operating mechanism mounted on the main breaker. If, however, it becomes necessary to remove the mechanism it should be refitted horizontally as shown in (Fig. 9a), using the holes in the frame as indicated in (Fig. 9b).

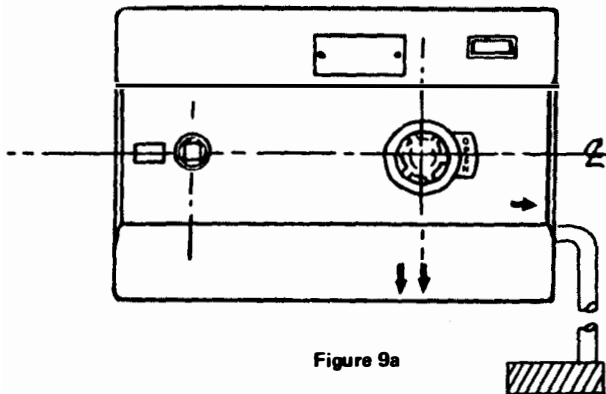

Figure 9a

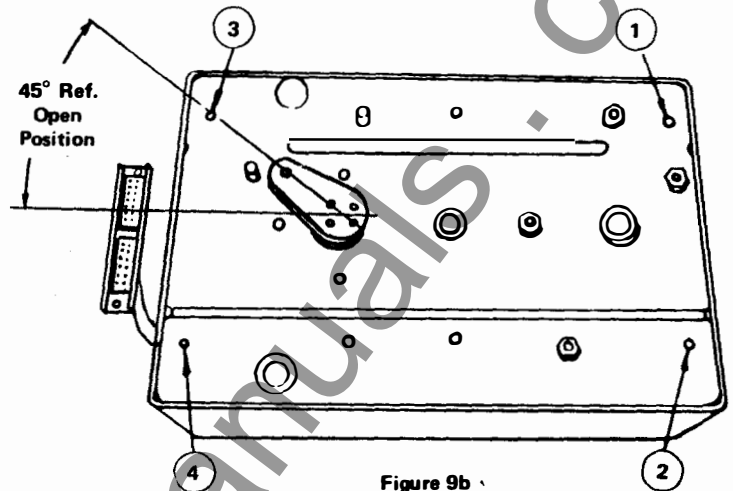

Figure 9b

NOTE: Mechanism should be assembled in the "Open" position and closing springs "Discharged". Moving contacts should be in the "Fully Open" position.

APPENDIX 8

RECOMMENDED MAINTENANCE SCHEDULE FOR THE DST-2 TYPE BREAKER

MAINTENANCE TO BE CARRIED OUT		NUMBER OF OPERATIONS	
		5kV 250 & 15kV 500 = 10,000 max. Every 2000	5kV 350 & 15kV 750 = 5,000 max. Every 4000 Or Once Annually, if Less
INSPECTION	Arc chutes (1)	X	
	Main contacts		X
	Arcing contacts (2)	X	
	Main contact lubrication	X	
	Tightening of nuts, screws, etc.	X	
	Tightening of connections, shunt trip	X	
	Operating mechanism chain.		X
	Auxiliary contacts on the operating mechanism	X	
Closing release latch		X	

(1) The arc chutes can withstand without being serviced:					
Mechanical Operations		Interruptions with rated current rated voltage $\cos \phi = 0.8$		Interruptions with the full short-circuit current at rated voltage $\cos \phi = 0.15$	
number	with inspection every	number	with inspection every	number replacement	with inspection after
10,000	2,000	5,000	2,000	as required	1 duty cycle

(2) The lifetime of arcing contacts depend on the nature of operations. Their condition is to be inspected: replacement is required when their wear is noticeable. Numbers of operations that the arcing contacts can withstand without being replaced are indicated below.	
Interruptions with rated current at rated voltage $\cos \phi = 0.8$	Interruptions with the full short-circuit current at rated voltage $\cos \phi = 0.15$
5,000	1 duty cycle

APPENDIX 9

OPERATING TIME & CONTACT VELOCITIES OF DST-2 – 5 & 15kV

Circuit Breaker	Opening Velocity in Ft/Sec	Closing Velocity in Ft/Sec	Opening Time in Milliseconds	Closing Time in Milliseconds
5kV 75 -1200A 5kV 150-1200A 5kV 250-1200A 5kV 350-1200A	12.4–14.1	17.0–18.7	40-50	60-70
5kV 250-2000A 5KV 350-2000A & 3000A	12.4–14.1	15.4–17.0	40-50	60-70
15kV 150-1200A 15kV 250-1200A 15kV 500-1200A 15kV 500 & 750-1200A	14.4–15.7	18.7–20.3	40-50	70-80
15kV 500-2000A 15kV 750-2000A & 3000A	14.4–15.7	16.4–18.0	40-50	70-80

Note: Closing velocity measured in area 1½ inch before “arc contact touch” to “arc contact touch”.

Opening velocity measured in area from “arc contact touch” to 1½ inch from “arc contact touch”.

APPENDIX 10

DST-2 AIR CIRCUIT BREAKER CONTROL POWER REQUIREMENTS

AVAILABLE TRIPPING VOLTAGE

Voltage, Nominal	24 VDC	48 VDC	125 VDC	250 VDC	115 VAC 230 VAC CAPACITOR TRIP	
Voltage Range	14 – 30	28 – 60	70 – 140	140 – 280	95 – 125	170 – 250
Current Required (Intermittent) At Nominal Voltage	12.5	6.25	2.4	1.2	0.1 max.	0.1 max.
Recommended Fuse	None	None	None	None	None	None

AVAILABLE SPRING CLOSING MOTOR VOLTAGES

Voltage, Nominal	48 VDC	125 VDC	250 VDC	115 VAC	230 VAC
Voltage Range	36 – 60	90 – 130	180 – 260	95 – 125	190 – 250
Current Required	14	5.3	2.65	5.2	2.6
* Recommended Fuse (FPE ECN 250V Dual Element)	8	3.2	1.6	3.2	1.6

AVAILABLE CLOSING RELEASE COIL VOLTAGES

Voltage, Nominal	24 VDC Special	48 VDC	125 VDC	250 VDC	115 VAC	230 VAC
Voltage Range	18 – 30	36 – 60	90 – 130	180 – 260	95 – 125	190 – 250
Current Required At Nominal Voltage	12.5	6.25	2.4	1.2	4.4	2.2
Recommended Fuse (FPE ECO @ 250V One-time Cartridge)	10	10	10	10	10	10

* Use fuse recommended for motor circuit when close and motor circuit have common power supply.

APPENDIX 11

WIRING DIAGRAM

Com

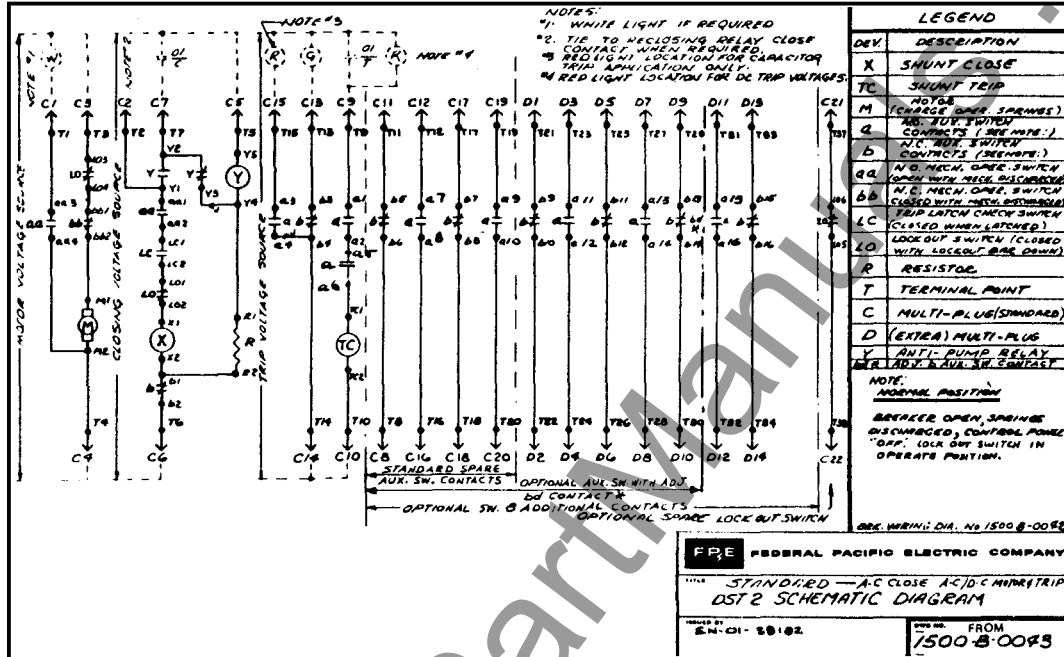

AC Close

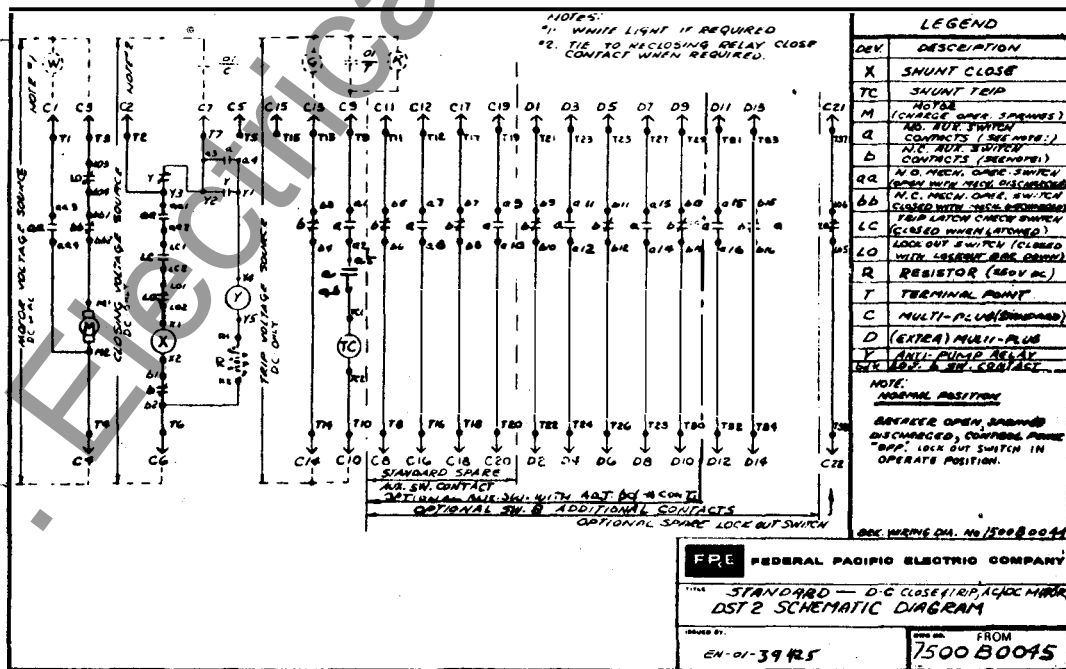

DC Close

motor C-4
 close C-17
 Trip 4-3
 Trip 9710

APPENDIX 12

Standard and Optional Accessories

SPRING CHARGING CRANK

DWG. NO. 1551 A 5539 (Standard)

1. Attach crank to square shaft at front left of mechanism.
2. Rotate until ratcheting ceases. The closing springs are then charged.

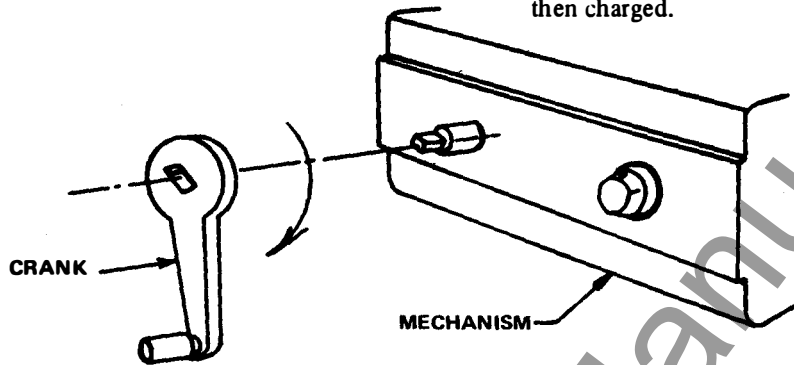

RACKING HANDLE,

DWG. NO. 2251 B 5412 (Standard)

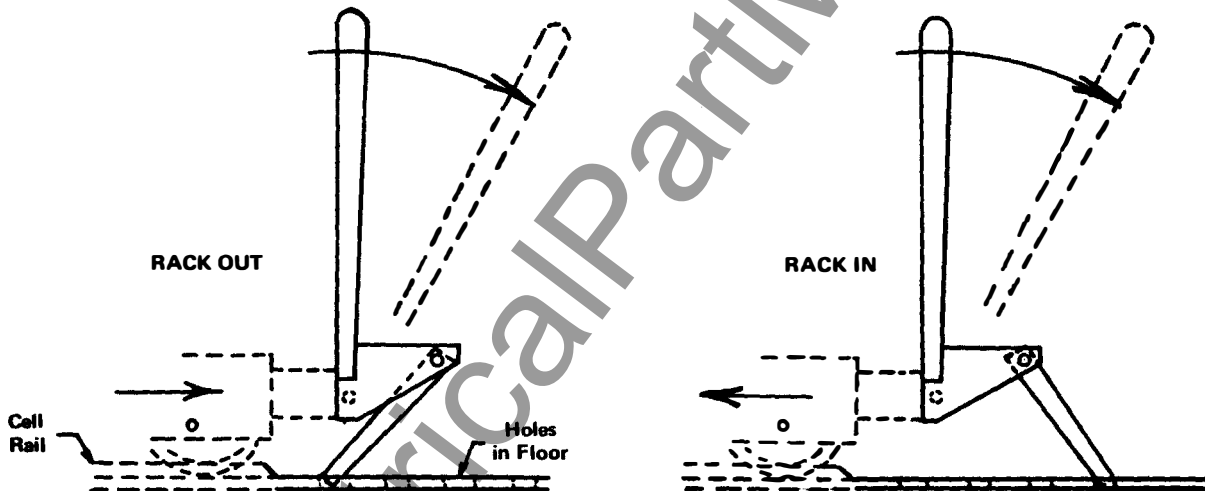

1. With circuit breaker on rails of cell, attach racking handle in accordance with above diagram.
2. If circuit breaker is in either test or operating position, depress pedal (14, Fig. 1) and rack. Racking from other positions does not require depressing of the pedal.

HANDLING DOLLY

DWG. NO. 2254 C 4327 (Optional)

1. Position dolly against left side of racking handle engagement block and with lifting angle under frame.
2. Rotate lever by pressing on right side until circuit breaker front wheels are off the ground.
3. Circuit breaker could now be pushed in any direction.
4. Disengage by pressing on left side and then allowing lever to rotate upward.

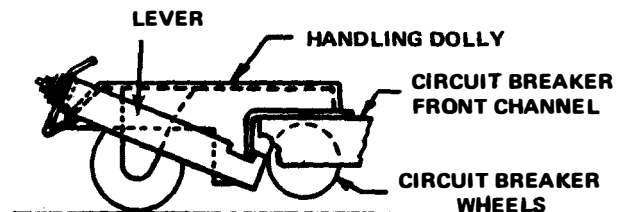

TRANSFER TRUCK

For outdoor non-walk-in 5 and 15kV switchgear.

	5kV	2251 D 4689
6" High Base	15kV	2251 D 4690
13½" High Base	5kV	2251 D 4691
	15kV	2251 D 4692

HANDLING DOLLY

DWG. NO. 2251 C 4842 (Standard)

1. Position wheel below circuit breaker racking block with dolly handle up.
2. Lower handle to approximate position as shown.
3. Circuit breaker could now be pushed in any direction by turning handle.

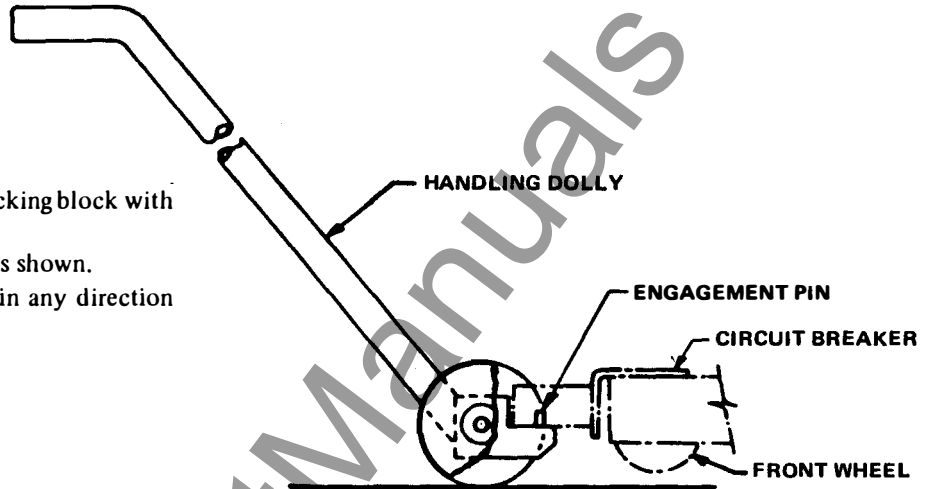

5kV ARC CHUTE LIFTING YOKE, DWG. NO. 1552 B 5597

15kV ARC CHUTE LIFTING YOKE, DWG. NO. 1551 B 5597

(Standard)

1. Attach arc chute lifting yoke and tighten clamping screws securely.
2. Lift by means of lifting hook or sling at point "A"; arc chute will swing at proper angle for removing or assembling on to circuit breaker.

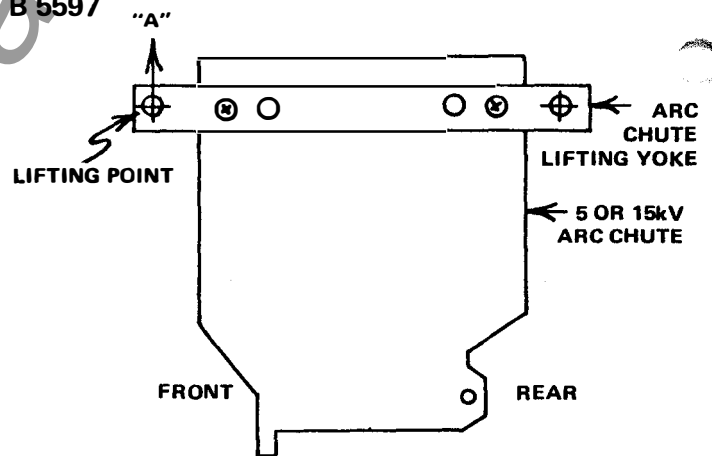

5kV MAINTENANCE CLOSE HANDLE DWG. NO. 1551 B 5628

(Standard)

1. Attach handle to main shaft as shown.
2. Rotate downwards until contacts touch and inspect contact sequence.

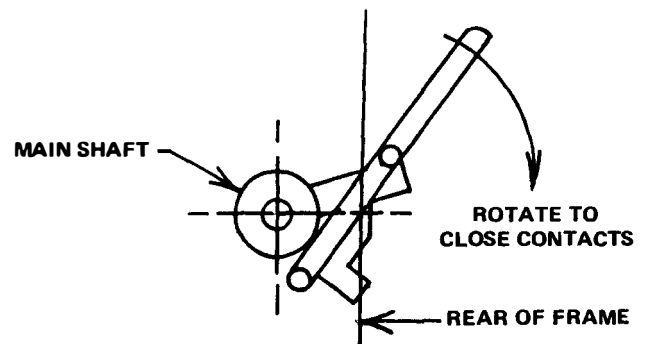

**15kV MAINTENANCE CLOSE,
DWG. NO. 1551 C 5820 (Standard)**

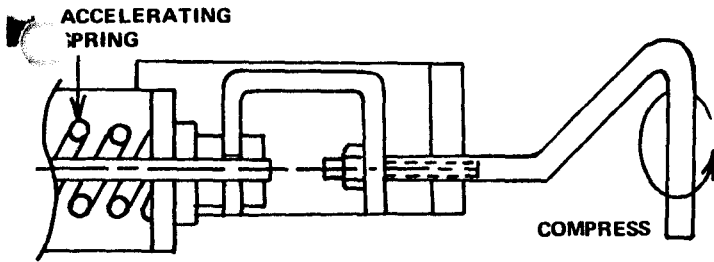

1. Attach handle to extension of accelerating spring as shown.
2. Compress accelerating spring by turning handle CCW.
3. Rotate contact blades by hand and inspect contact sequence.

TEST JUMPER, DWG. NO. 2251 C 4509 (Optional)

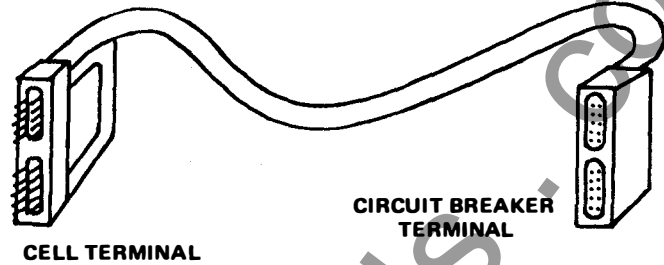

1. With circuit breaker near the cell, insert one end of the jumper to the circuit breaker secondary disconnect terminal.
2. Insert the other end to the cell secondary disconnect terminal. The circuit breaker could now be tested electrically from switch on instrument door.

TEST CABINET ASS'Y DWG. NO. 2251 D 4340 (Optional)

1. With the circuit breaker removed from the cell and moved near the test cabinet, insert one end of the test jumper to the circuit breaker.
2. Connect the other end to the Test Cabinet secondary disconnect terminal. The circuit breaker can now be tested electrically from the test cabinet.

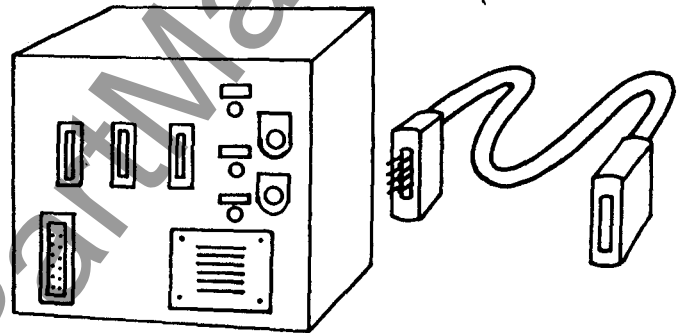

APPENDIX 13

TABLE OF SPARE PARTS FOR BREAKER SERIES DST-2

Typical part numbers shown. Breaker Serial Numbers must be given when ordering replacement parts.

No.	Sketch	Description	Quantity for 1 Breaker	Part No.	Type of Breaker
1		Arc Chute	3	1551 D 5464	5kV 250 MVA
				1551 D 6006	5kV 350 MVA
				1552 D 5484	15kV 500 MVA
				1553 D 5484	15kV 750 MVA
2		Fixed Arcing Contact	3 Pairs	1565 D 5641	5kV 350 MVA 15kV 750 MVA
				1551 D 5641	5kV 250 MVA 15kV 500

TABLE OF SPARE PARTS FOR BREAKER SERIES DST-2



No.	Sketch	Description	Quantity for 1 Breaker	Part No.	Type of Breaker
3		Moving Arcing Contact	3	1552 D 5641	5kV 250 MVA & 350 MVA
				1569 D 5641	15kV 750 MVA
4		Moving Arcing Contact	3	1553 D 5641	15kV 500 MVA
5		Main Fixed Contact	24	1571 D 5641	15kV 500 MVA 1200A
			48	1571 D 5641	15kV 750 MVA 1200A
			48	1555 D 5641	5kV 250 and 350 MVA 1200A
			48	1554 D 5641	15kV 500 & 750 MVA 2000A and 3000A
6		Leading Finger for Moving Contact	6	1568 D 5641	5kV 250 MVA 2000A 5kV 350 MVA 1200 & 2000A 15kV 750 MVA 2000A
				1556 D 5641	5kV 250 MVA 1200A 5kV 350 MVA 3000A 15kV 750 MVA 1200 & 3000A
7		Fixed Arcing Contact Spring	6	1557 D 5641	15kV 500 MVA
				1558 D 5641	5kV 250 MVA, 350 MVA, and 15kV 750 MVA

TABLE OF SPARE PARTS FOR BREAKER SERIES DST-2

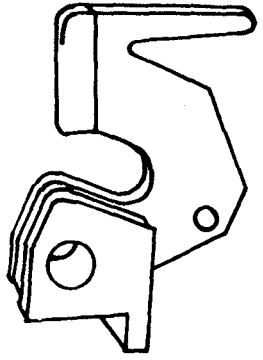
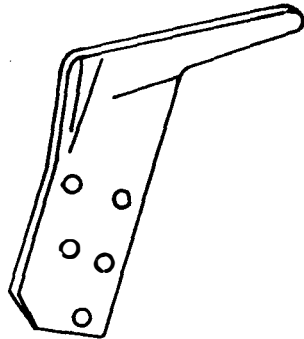
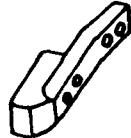
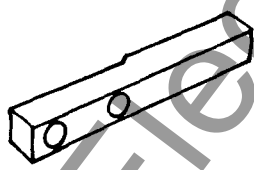

No.	Sketch	Description	Quantity for 1 Breaker	Part No.	Applied Voltage
8		Rotating Moving Arcing Contact Spring	3	1559 D 5641	5kV 250 MVA, 350 MVA, and 15kV 750 MVA
9		Main Fixed Contact Spring	24	1560 D 5641	All 5 and 15kV
10		Type AEM Mechanism	1	1551 B 6044	5kV 250, 1200 & 2000A 15kV 500, 1200 & 2000A
				1552 B 6044	5kV 350, 1200, 2000 & 3000A 15kV, 750-3000A
				1553 B 6044	15kV 750-1200 & 2000A
11		Shunt Close Assembly	1	1556 A 5575	24VDC
				1551 A 5575	48VDC & 115VAC
				1552 A 5575	125VDC [#] 223
				1553 A 5575	250VDC
				1555 A 5575	230VAC
12		Y Relay Assembly	1	1551 B 5758	48VDC
				1552 B 5758	125VDC [#] 324
				1553 B 5758	250VDC
				1554 B 5758	115VAC
				1555 B 5758	230VAC
				1556 B 5758	24VDC

TABLE OF SPARE PARTS FOR BREAKER SERIES DST-2

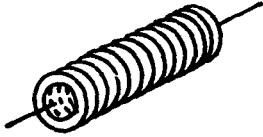

No.	Sketch	Description	Quantity for 1 Breaker	Part No.	Applied Voltage
13		Shunt Trip Assembly	1	1551 C 5584	24VDC
				1552 C 5584	48VDC
				1553 C 5584 # 274	125VDC 115/230VAC CAP. TRIP.
				1554 C 5584	250VDC
14		Spring Charging Motor	1	1551 B 5585	48VDC
				1553 B 5585	250VDC
				1554 B 5585	115 VAC & # 125VDC 1147
				1555 B 5585	230 VAC
15		<i>Auxiliary Switch</i> Basic breaker is equipped with 5 unit aux. switch which provides "2a" and "2b" spare contacts. It is not necessary to specify this switch on breaker orders.	1	1551 D 5557	All
		7 Unit aux. switch with 5a & 5b spare contacts. Convertible contact b13-b14 is adjustable with infinite resolution.	1	1552 D 5557	All
		8 unit aux. switch with 6a & 6b spare contacts.	1	1553 D 5557	All
16		<i>Lockout Switch</i> Basic breaker is equipped with 2 pole lockout switch used for internal control. It is not necessary to specify this switch on breaker order.	1	1501 A 5592	AC Charging Motor Applications
		Lockout switch with one additional spare contact.	1	1502 A 5592	90,20 DC Charging Motor Applications

TABLE OF SPARE PARTS FOR BREAKER SERIES DST-2

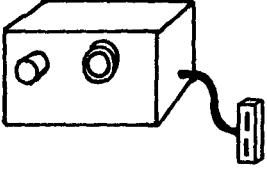
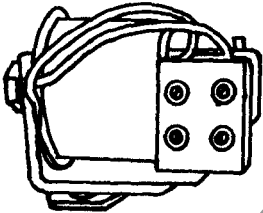
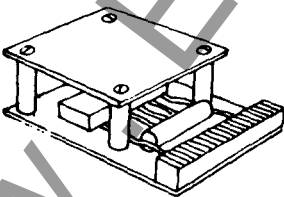
No.	Sketch	Description	Quantity for 1 Breaker	Part No.	Applied Voltage
17		Latch Switch	3	1564 D 5641	All 53.00
18		Secondary Disconnect Contact Assembly with 24 contacts	1	1551 B 5369	24 Pins
		16 Contact Block if req'd.		1502 A 5418	16 Pins
19		Primary Disconnect Contact Assembly	6	1553 A 5533	1200A
				1551 B 5675	2000A
20		Primary Disconnect Contact Assembly	6	1572 D 5641	5kV 350 3000A & 15kV 500 or 750 3000A

www.ElectricalPartManuals.com

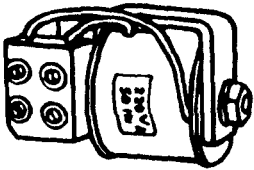
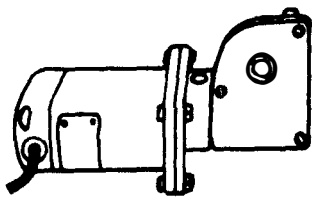
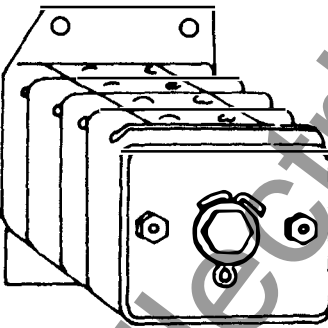
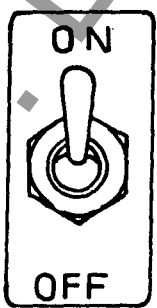
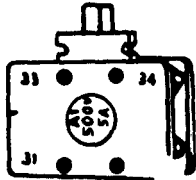
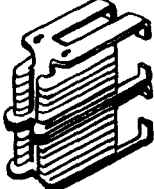