

LOW-VOLTAGE POWER CIRCUIT BREAKERS
INSTRUCTIONS

TYPE K-3000, K-4000,
K-3000S, K-4000S CIRCUIT BREAKERS

Stationary Switchboard Mounted and Drawout Mounted

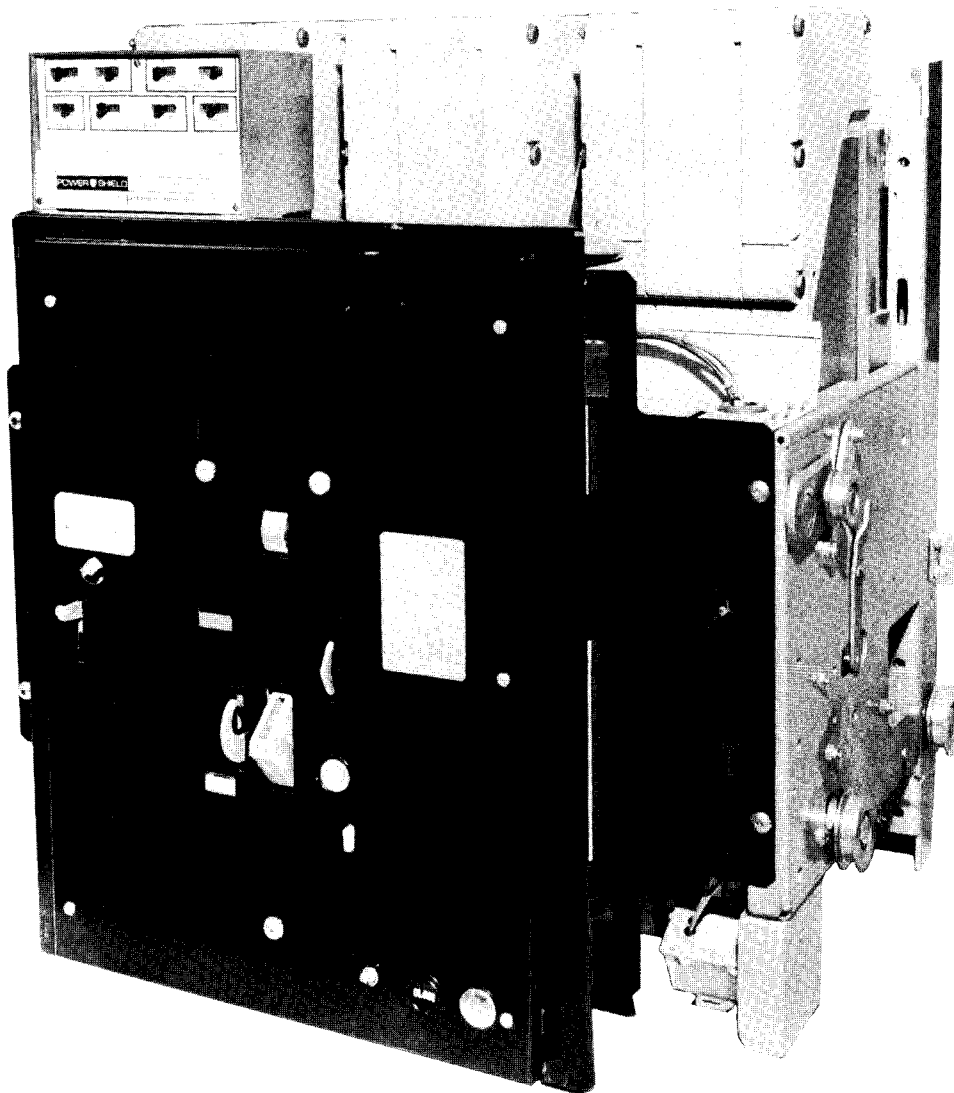

ITE Imperial Corporation



CONTENTS

	Page
Introduction	3
Receiving and Storage	3
Basic Handling Instructions	3
Circuit Breaker Operation	3
Circuit Breaker Rating	3
Closing Spring Operation	3
Escutcheon Operating Features	5
Circuit Breaker Nameplate	5
Manual Charging Handle	5
Manual Trip Button	5
Circuit Breaker "Open" or "Closed" Indicator	5
Automatic Trip Indicator	5
Automatic Trip Alarm Contacts	5
Automatic Trip Lockout	5
Padlocking Device	5
Closing Spring Charge Indicator	5
Motor Disconnect Switch	6
Electrical Close Push Button	6
Manual Close Lever	6
Racking Mechanism (Drawout Breaker)	6
Operation of Devices	6
Electro-Mechanical Overcurrent Trip Devices	6
Power Shield Solid State Overcurrent Trip Devices	6
Control Relay	8
Auxiliary Switches	8
Undervoltage Trip Device	8
Installation, Initial Testing and Removal	9
Installation	9
Checking Circuit Breaker Operation	9
Manual Closing Operation	9
Circuit Breaker Removal (Drawout Type)	10
Maintenance and Adjustments	10
Safety Notes	10
Periodic Maintenance Inspection	10
Arc Chutes	10
Insulation Structure	10
Contacts	10
Contact Pitting	10
Contact Pressure Check and Adjustment	11
Manual Slow Close to Check Contact Pressure	11
Operating Mechanism	13
Primary Trip Latch	13
Tripper Bar Adjustment	13
Primary Close Latch	13
Shunt Trip Device	13
Magnetic Latch Device	13
Electro-Mechanical Overcurrent Trip Device Adjustments	14
Solid State Overcurrent Trip Device Settings	15
Lubrication	15
Dielectric Test	15
Electrical Characteristics of Control Devices	16
Renewal Parts	16



INSTRUCTIONS FOR TYPE K-3000, K-4000, K-3000S, K-4000S CIRCUIT BREAKERS

Stationary Switchboard Mounted and Drawout Mounted

INTRODUCTION

These instructions apply to the type K-3000 and K-4000, K-3000S and K-4000S circuit breakers; 3000 and 4000 ampere ac continuous current rating respectively. The type K-3000 and K-4000 are equipped with electromechanical overcurrent trip devices, whereas the type K-3000S and K-4000S incorporate the solid state overcurrent trip devices. A K-3000S circuit breaker is shown on the front cover of this bulletin.

The K-3000 and K-4000 circuit breakers can be furnished with two or three poles for dc or ac operation. K-3000S and K-4000S circuit breakers are only furnished for three pole ac operation.

All circuit breakers can be furnished as drawout or stationary mounted and are available as manually or electrically operated, and with electrical control devices available in various ac and dc voltage combinations. Many optional features are also available.

An electrical operated, drawout type circuit breaker is shown in Figure 1, with a typical schematic diagram shown in Figure 2.

These instructions should be read thoroughly before handling, installing and/or operating the circuit breaker.

RECEIVING AND STORAGE

Immediately upon receipt of the circuit breakers, examine the cartons to determine if any damage or loss was sustained during transit. If injury or rough handling is evident, file a damage claim at once with the carrier and promptly notify the I-T-E Imperial Corporation. The I-T-E Imperial Corporation is not responsible for damage of goods after delivery to the carrier. However, the I-T-E Imperial Corporation will lend assistance if notified of claims.

Unpack the circuit breakers as soon as possible after receipt. If unpacking is delayed, difficulty may be experienced in making a claim for damages not evident upon receipt. Use care in unpacking in order to avoid damaging any of the circuit breaker parts. Check the contents of each carton against the packing list before discarding any packing material. If any shortage of material is discovered, promptly notify the nearest representative of the I-T-E Imperial Corporation. Information specifying the purchase order number, carton number and part numbers of the damaged or missing parts should accompany the claim.

Circuit breakers should be installed in their permanent location as soon as possible. (See Basic Handling below.) If the breakers are not to be placed in service for some time, it is advisable to provide adequate means of protection. This may be done by keeping the breaker on its original skid, covering with waterproof paper and sealing to prevent infiltration of dirt. Where conditions of high humidity prevail, the use of heaters is recommended.

BASIC HANDLING INSTRUCTIONS

Once the circuit breaker has been unbolted and removed from its shipping skid, it should be turned to the upright position and placed on a flat surface to avoid damage to breaker parts. For safety, all handling in this position should utilize the lifting yoke (20) shown in Figure 1.

CIRCUIT BREAKER OPERATION

CIRCUIT BREAKER RATING

The K-3000/K-3000S and K-4000/K-4000S circuit breakers are designed to carry a maximum ac continuous current of 3000 amperes and 4000 amperes respectively. Exceeding these ratings may raise the temperature of the breakers beyond their design limit and thus affect the life of the breaker. Thus, any long-time pickup setting exceeding 100% of the frame size is to be used only for coordination, not for carrying increased continuous current.

CLOSING SPRING OPERATION

The two closing springs supply the power that closes the circuit breaker and also charge the two opening springs during the closing operation. The closing springs are charged by a motor in the electrically operated breaker and charged by hand in the manually operated breaker; however, in either type, the springs are charged the same amount and when charged, the spring energy is available to close the breaker, thus referred to as "stored energy." The closing springs are normally charged when the breaker is opened. If charged after closing, the breaker may be opened and then reclosed without recharging the springs. In drawout breakers, the closing springs are automatically discharged when the breaker is moved from the disconnected to the withdrawn position (shown in Figure 1). This prevents accidental discharge.

These instructions do not purport to cover all details or variations in equipment nor to provide for every possible contingency to be met in connection with installation, operation, or maintenance. Should further information be desired or should particular problems arise which are not covered sufficiently for the purchaser's purposes the matter should be referred to the I-T-E Imperial Corporation.

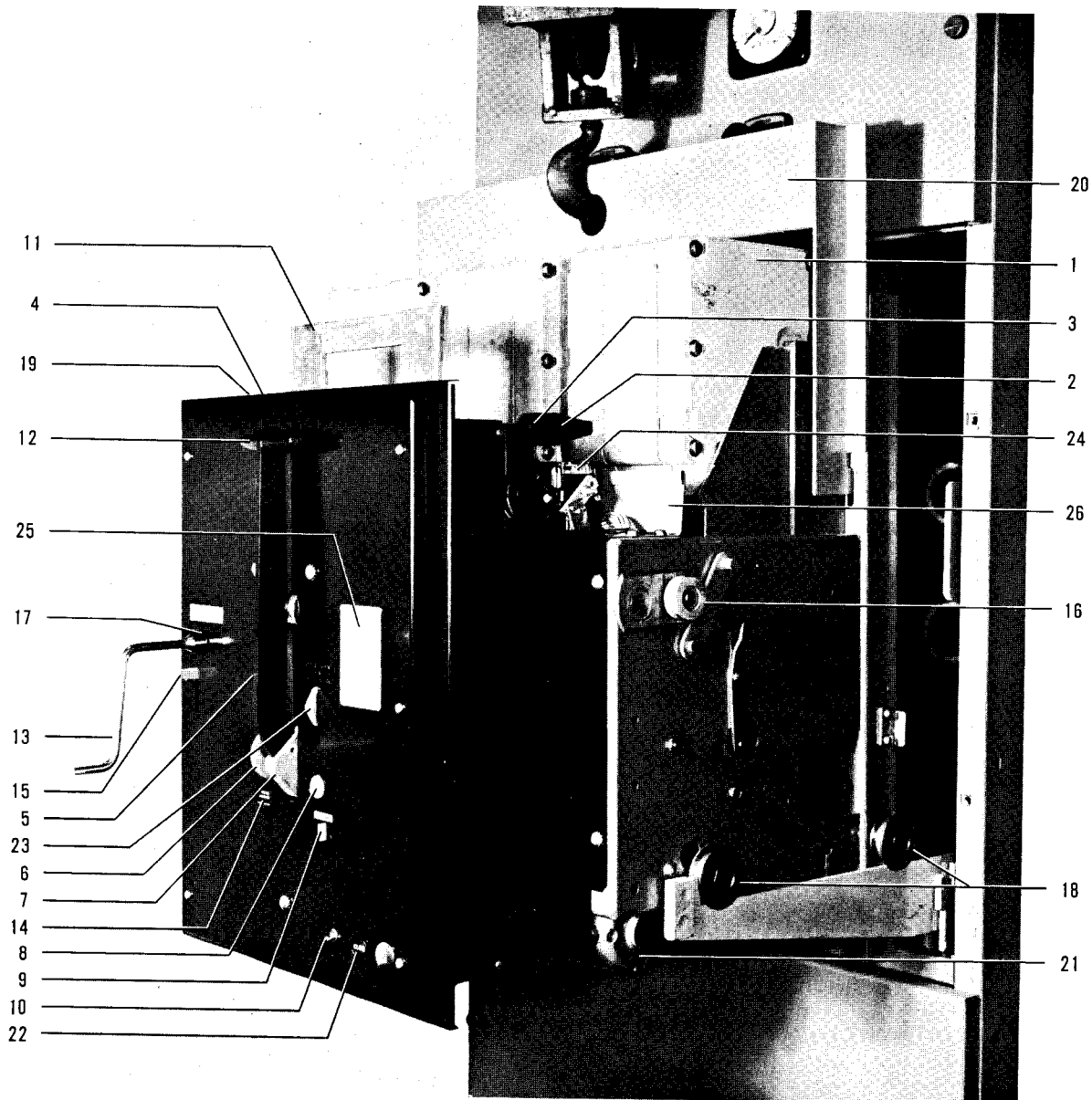

- | | | |
|--|--|-----------------------------------|
| 1. Arc Chute | 11. Spring Retainer Bracket | 21. Closing Spring Charging Motor |
| 2. Arc Chute Retainer Molding | 12. Manual Charge Handle | 22. Electrical Close Button |
| 3. Arc Chute Mounting Screw | 13. Racking Crank | 23. Locking Hasp |
| *4. Shutter | 14. Closing Spring Charge Indicator | 24. Auxiliary Switch |
| *5. Visual Indicator for
Breaker "Closed" or "Opened" | 15. Drawout Lever | 25. Nameplate |
| 6. Manual Close Lever | 16. Racking Cam Rollers | 26. Plate |
| 7. Manual Charging Lever | 17. Racking Crank Opening | |
| 8. Manual Trip Button | 18. Wheels | |
| 9. Automatic Trip Indicator | *19. Shutter Lock Screw
(Inserted in Shutter) | |
| 10. Motor Disconnect Switch | 20. Lifting Yoke | |

*Not Visible in This View

Fig. 1 — Typical Electrically Operated, Drawout Type
K-3000 Circuit Breaker



ESCUTCHEON OPERATING FEATURES

Manually and electrically operated circuit breakers are provided with an extendible escutcheon face plate. This escutcheon provides a central area for the controls which are mounted directly on the circuit breaker.

The controls for manually operated circuit breakers, Figure 1, included in the escutcheon face plate are: (25) a nameplate giving the various ratings assigned to the particular type of circuit breaker, (12) the manual charging handle, (8) the manual trip button, (5) the "OPEN" and "CLOSED" position indicator, (9) the automatic trip indicator with optional facilities for alarm indication and for lockout, (23) a means for padlocking the circuit breaker in the "CONNECTED," "TEST" or "DISCONNECTED" positions, and (14) closing spring charging indicator.

The controls for the electrically operated circuit breakers, Figure 1, are the same as the manually operated circuit breakers except the charging handle (12) is removed and stored for maintenance use, and the presence of (10) motor disconnect switch for the motor electrical circuit and (22) electrical close push button switch.

The manually and electrically operated drawout circuit breaker escutcheon also contains the racking crank opening (17) and interlocking drawout lever (15).

A self-aligning plate, immediately behind the escutcheon face plate, is used to exclude dust from the circuit breaker compartment. On drawout type circuit breakers, the escutcheon face will protrude through the front door of the compartment when the circuit breaker is in the "TEST" and "DISCONNECTED" positions. In these positions, the dustplate still functions to exclude dust.

Circuit Breaker Nameplate (Figure 1, Item 25)

The circuit breaker nameplate contains information regarding (1) the manufacturer's name and address, (2) type of circuit breaker design, (3) serial number of circuit breaker, (4) continuous current rating of frame size, (5) short circuit current rating at rated voltages, (6) frequency, (7) short time current.

Manual Charging Handle (Figure 1, Item 12)

The manual charging handle is a T-shaped lever used to charge the closing springs by pumping approximately ten times.

Manual Trip Button (Figure 1, Item 8)

The manual trip button, when pushed, trips the circuit breaker to "OPEN."

Circuit Breaker "OPEN" or "CLOSED" Indicator (Figure 1, Item 5)

This indicator shows the physical position of the circuit breaker contacts.

Automatic Trip Indicator (Figure 1, Item 9) (Not including undervoltage, alarm switch or lockout)

The automatic trip indicator is provided as standard equipment on the K-line® circuit breakers and is used to indicate the operation of the overcurrent trip device.

This device is an indicator only and does not prevent the circuit breaker reclosing.

Upon an overcurrent trip operation, the indicator protrudes from the front plate approximately 1/2 inch.

The automatic trip indicator should be reset after each trip indication by pushing back into its normal latch position. The operator should investigate the cause of tripping before resetting the automatic trip indicator and subsequent reclosing the circuit breaker after an outage which results in an operation of the indicator.

Automatic Trip Alarm Contacts (Hand Reset)

(Figure 1, Item 9)

An alarm switch for remote electrical indication, which is optional, shows when automatic tripping has occurred. This is accomplished by adding a precision snap switch to the automatic trip indicator assembly. The automatic trip indicator actuates the roller on the alarm switch which in turn causes a normally open contact to close and a normally closed contact to open on overcurrent trip. The alarm contact is manually reset by pushing the trip indicator (9) back into its normal position.

Automatic Trip Lockout (Hand Reset) (Figure 1, Item 9)

An additional device (which is also optional) may be added to the automatic trip indicator assembly device which serves to mechanically prevent reclosing the circuit breaker after an automatic trip operation. When the trip indicator is pushed in the circuit breaker mechanism can then be operated to close the circuit breaker contacts.

Padlocking Device (Figure 1, Item 23)

All K-line circuit breakers are equipped with means of padlocking the circuit breaker mechanism in a trip-free position. This is accomplished by the use of a locking plate to maintain the manual trip button in a tripping direction when the locking plate is held forward by one or more padlocks. To obtain the condition for padlocking the circuit breaker in the open position, the manual trip button is pushed inward. Then the padlock plate is pulled out and the padlock inserted into the vertical slot. In this position, the mechanism is maintained trip free and the contact arm cannot be moved to the closed position.

On circuit breakers equipped with drawout mechanism, the padlocking device is associated with the drawout interlocking mechanism so that the circuit breaker cannot be moved from any of its three basic drawout positions of "CONNECTED," "TEST" or "DISCONNECTED" with the padlocking in effect.

Closing Spring Charge Indicator (Figure 1, Item 14)

Under normal operating conditions, the closing springs are automatically charged after each tripping operation. However, there are occasions when the springs will be in a discharged state. Therefore, it is desirable that means be available to indicate the charged or uncharged condition of the closing springs. This is accomplished by a visual indicator seen through an aperture in the escutcheon plate. The indicator is marked "CHARGED" and "UNCHARGED."



Motor Disconnect Switch (Figure 1, Item 10)

The motor disconnect switch is a double pole, single-throw toggle type switch connected in series with the charging motor circuit and is used to disconnect the motor from the voltage source. This switch is used (1), when it is desirable to prevent automatic recharging of the closing springs just prior to taking the circuit breaker out of service for maintenance and (2), for control wiring dielectric test. The motor must be disconnected for the control wiring dielectric test and subsequently tested at 540 V ac or 760 V dc.

Electrical Close Push Button (Figure 1, Item 22)

The electrical close push button is used to electrically close the circuit from the escutcheon. This contact is connected in series with the latch release coil. Energizing the latch release coil allows the charged springs to close the circuit breaker.

Manual Close Lever (Figure 1, Item 6)

The manual close lever is provided on all circuit breakers to provide a safe means of closing the breaker without control power. The lever is provided with a ring to which a lanyard should be attached for closing the breaker at a safe distance.

Racking Mechanism (Drawout Breaker)

The racking mechanism is used to move the circuit breaker to any one of its three positions—"CONNECTED," "TEST" or "DISCONNECTED." All of these positions are attainable with the cubicle door closed or opened. The breaker can be closed only when the drawout lever (15, Figure 1) is up and when up, the racking crank (13, Figure 1) cannot be turned.

The circuit breaker must be in the "OPEN" position before lever (15, Figure 1) can be pushed down. In order to move the circuit breaker from one position to another, the lever must be pushed down and the crank turned; once turning begins, the lever will stay down until another position is reached and the lever will snap up, preventing additional turning, until the lever is again pushed down.

When the padlocking device is locked, the lever (15) is locked in the up position preventing movement of the racking mechanism.

Figure 1 shows the breaker in the fully withdrawn position.

There are two sets of indicator lines on the left side of the breaker to show breaker position. One set is visible with the switchboard door closed, the other visible when the door is open.

OPERATION OF DEVICES

Electro-Mechanical Overcurrent Trip Devices Type K-3000 and K-4000 Circuit Breakers (Figures 10 and 11)

(A) Type OD-300 General Purpose Overcurrent Trip Device. The type OD-300 overcurrent trip device, for general purpose applications, provides long-time delay tripping on moderate overcurrents which are above the long-time pickup setting; and instantaneous tripping on fault currents above the instantaneous trip setting. This

device must be properly set to provide adequate protection for an electrical system. Three adjustment screws on the bottom of the device provide independent control of the long-time pickup, instantaneous pickup and amount of time delay. The nameplate of this device shows the setting of these adjustments and the range of settings which are available. For information on the time-current characteristics of this device, request a copy of TD-6693.

(B) Type OD-400 Selective Overcurrent Trip Device. The type OD-400 overcurrent trip device, for selective tripping applications, provides long-time delay and short-time delay tripping. Independent adjustment of both pickup and time delay is provided for both types of tripping. The nameplate of this device shows the settings which are available. For information on the time-current characteristics of this device, request a copy of TD-6694.

(C) See Table 1 for complete list of Electro-Mechanical overcurrent trip devices available.

Power Shield™ Solid State Overcurrent Trip Devices Type K-3000S and K-4000S Circuit Breakers (See Figure 12)

This device includes the power supply sensors, overcurrent sensors, Power Shield solid state logic assembly, magnetic latch and the interconnecting wiring. Each phase of the circuit breaker has a power supply sensor and overcurrent sensor. The trip elements that are available are: long-time delay, instantaneous, short-time delay and ground fault. On a 3-phase 4-wire system, an additional remote sensor, mounted in the neutral bus, is required for complete ground fault protection.

The logic assembly is mounted near the front of the circuit breaker and with the cubicle door open the overcurrent control panel is readily accessible. This device must be properly set, as required by individual circuit conditions, to provide adequate protection for an electrical system. The movable plugs on the control panel provide independent control of the long-time, short-time, instantaneous and ground fault pickup and amount of time delay. The overcurrent device, with the exception of ground fault, will trip at the value of the AMPERE TAP setting times the plug setting of the various pickup elements. The ground fault trip value will be the plug setting value times 100, as indicated on the nameplate.

(A) Type SS-3. This trip device is for general purpose application. It provides long-time delay tripping on moderate overcurrents, which are above the long-time pickup settings, and instantaneous tripping on fault currents above the instantaneous trip setting. For information on the time-current characteristics of this device, request a copy of TD-6966.

(B) Type SS-4 Selective Overcurrent Trip Device. This trip device, for selective tripping application, provides long-time delay and short-time delay tripping. For information on the time-current characteristics of this device, request a copy of TD-6967.

(C) Type SS-5 Triple-Selective Overcurrent Trip Device. This device includes the trip elements found in both the SS-3 and SS-4; i.e., long-time delay, short-time



delay, and instantaneous tripping. For information on the time-current characteristics of this device, request a copy of TD-6967.

(D) The above three solid state overcurrent trip devices are available with ground fault protection and

are designated by the types SS-3G, SS-4G and SS-5G. For information on the time current characteristics of this feature, request a copy of TD-6968.

(E) See Table 1A for a complete list of standard Solid State overcurrent trip devices.

TABLE 1
STANDARD ELECTRO-MECHANICAL OVERCURRENT TRIP DEVICES

Overcurrent Device Type	Trip Element			Time-Current Characteristic Curve
	Long-Time	Short-Time	Instantaneous	
OD-300	X		X	TD-6693
OD-400	X	X		TD-6694
OD-500	X	X	X	TD-6695
OD-600	X		X	TD-6695
OD-700			X	None
OD-800			X	None
OD-900		X	X	TD-6699
OD-1000		X		TD-6699

NOTE: OD-300 long-time delay element has one time delay band only. All other long-time & short-time delay elements have three time delay bands.

TABLE 1A
STANDARD SOLID STATE OVERCURRENT TRIP DEVICES

Overcurrent Device Type	Trip Element				Time-Current Characteristic Curve
	Long-Time	Short-Time	Instantaneous	Ground	
SS-3	X		X		TD-6966
SS-3G	X		X	X	TD-6966 TD-6968
SS-4	X	X			TD-6967
SS-4G	X	X		X	TD-6967 TD-6968
SS-5	X	X	X		TD-6967
SS-5G	X	X	X	X	TD-6967 TD-6968

NOTE: Time-current characteristic curves are not included in this book because separate coordination curves are normally provided with each order. When field calibration is performed, necessary instruction books (refer to page 15) will be provided and will include all pertinent timing information.



Control Relay

This device is contained in the black insulated molding, 3" x 5" x 6" approximate, located at the lower front of the mechanism and is used on all electrically operated mechanisms. The 52Y coil, and contacts 52Y/1, 52Y/2 are connected as shown in the schematic diagram, Figure 2. The purpose of this device is to require that, if the remote or local close contacts are closed, resulting in the charging springs discharging, the close contacts must first be released (opened) before the breaker can be reclosed. This prevents closing the breaker more than one time unless the close contacts are first released.

Auxiliary Switches

The auxiliary switches (24, Figure 1) contain the "a" and "b" contacts (Figure 2) and are furnished in 4 or 8 contact arrangements. They are mechanically interconnected with the main breaker contacts such that, with

the breaker closed, the "a" contacts are closed. With the circuit breaker open, the "b" contacts are closed.

Undervoltage Trip Device

The electrically reset undervoltage trip device is a single-phase device which automatically trips the circuit breaker when the line voltage decreases to 30 to 60 percent of the rated voltage. This device may be furnished either for instantaneous trip operation or with adjustable time delay tripping of 0-15 seconds. The undervoltage trip device is an integral unit which may be added to the circuit breaker either at the factory or in the field.

The undervoltage device may be connected so that the automatic trip indicator (Figure 1, Item 9) will protrude from the front plate when the breaker is tripped by the undervoltage device.

See Table 4, page 16, for electrical characteristics.

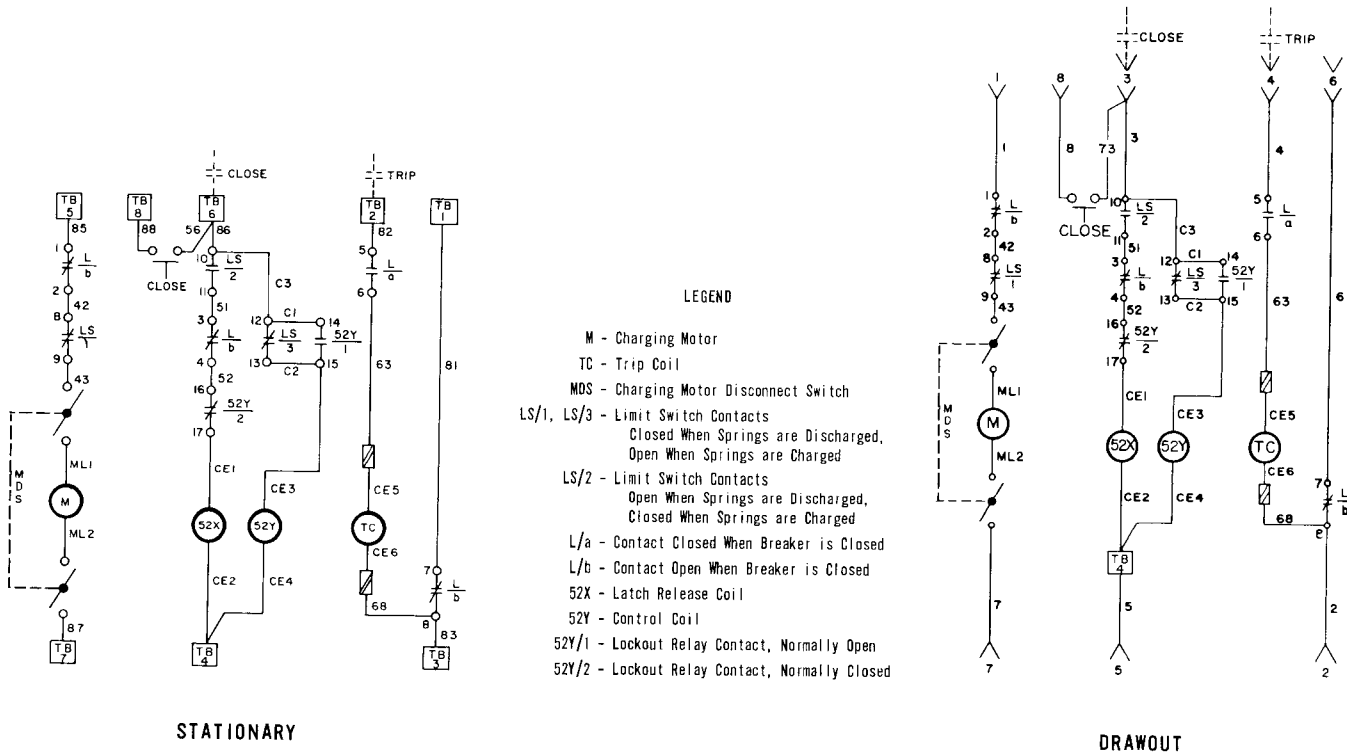

Fig. 2 — Typical Schematic Diagram of Control Circuit



INSTALLATION, INITIAL TESTING AND REMOVAL (Drawout & Stationary)

FOR SAFETY: When installing or removing stationary breakers, the supply for primary and control circuits must be de-energized at all times. Testing of stationary breakers to be done with the primary supply circuit de-energized.

For initial installation of drawout breakers in the "CONNECTED" position, the supply for the primary circuit should be de-energized. Testing of the drawout breaker to be done in the test position.

NOTE: (K-3000 and K-4000 Circuit Breakers) Prior to inserting the circuit breaker into the switchboard and with the breaker in the upright position, exercise the three long time armatures (1" wide armatures) several times until resistance to motion has increased, indicating that the oil dashpot is functioning properly. Improper operation can result because the circuit breaker is shipped or stored on its back. This causes the oil in the dashpot to be displaced and an air bubble can be trapped under the piston. The exercise removes the air to permit proper operation.

INSTALLATION (Drawout Type)

(See Figure 1)

The circuit breaker must be in the "OPEN" position, the racking crank (13) when inserted in opening (17) is rotated counterclockwise until the racking cam roller (16) is rotated down into a 45° angle, and the motor disconnect switch (10) for electrically operated circuit breakers is in the "OFF" position. **NOTE:** Lever (15) must be pushed down to permit the rotation of crank (13).

Open compartment door and lower the right and left hand tracks to fully extended position.

Use lifting yoke (20, Figure 1), which is inserted in holes in the upper rear frame, and lower circuit breaker wheels (18) onto track extensions. Remove lifting yoke.

Push circuit breaker into compartment until racking cam rollers (16) stop against their guides.

CAUTION: RAISE TRACK EXTENSION INTO COMPARTMENT BEFORE RACKING.

Insert racking crank (13) into opening (17) and depress drawout lever (15). Turn crank clockwise until automatically stopped. Breaker is now in "DISCONNECT" position. An arrow on the left side of plate (26) will also line up with "DISCONNECT" on the cradle.

Again depress drawout lever (15) and turn crank clockwise until automatically stopped. Breaker is now in "TEST" position.

INSTALLATION (Stationary Type)

Lifting yoke (20) should be used to move the breaker to the switchboard; however, other handling means will be required to move the breaker into position inside the switchboard.

CHECKING CIRCUIT BREAKER OPERATION IN "TEST" POSITION (Electrically Operated, Drawout Type)

(See Figure 1)

- a. Manually reset automatic trip indicator (9) if it protrudes approximately 1/2". Push in to reset.
- b. Turn motor disconnect switch (10) to "ON" position and closing springs will automatically charge.
- c. Close circuit breaker by local close button and trip by local trip button.

NOTE: All breakers have a manual trip button. The local close button for electrical breakers is standard. The local trip button for electrical breakers is optional.

- d. Close and trip circuit breaker by means of remote control switch.
- e. Check each auxiliary device for proper operation.

CHECKING CIRCUIT BREAKER OPERATION IN "TEST" POSITION (Manually Operated, Drawout Type)

(See Figure 1)

- a. Manually reset automatic trip indicator (9) if it protrudes approximately 1/2". Push in to reset.
- b. Charge and close circuit breaker; See "Manual Closing Operation" below.
- c. Trip by manual "TRIP" button (8).
- d. Check each auxiliary device for proper operation.

CHECKING CIRCUIT BREAKER OPERATION IN "CONNECTED" POSITION (Drawout Type)

After completing check procedures in "TEST" position, continue as follows:

With circuit breaker in "OPEN" position and motor disconnect switch (10) in "OFF" position, insert racking crank (13) in opening (17) and press down drawout lever (15). Rotate the racking crank clockwise until lever (15) moves up and cranking is automatically stopped. Breaker is now in "CONNECTED" position. Excessive cranking force indicates misalignment or interference of parts.

CHECKING CIRCUIT BREAKER OPERATION (Stationary Type)

Follow the same procedure as for drawout circuit breaker, except the circuit breaker will be in the "CONNECTED" position. Primary supply circuit must be de-energized.

MANUAL CLOSING OPERATION

The following manual closing procedures are recommended:

(See Figure 1)

- a. Observe circuit breaker conditions on control escutcheon.



b. If closing springs are discharged, manually charge closing springs by means of the manual charge lever (12) then pull the manual close lever (6) by a lanyard from a safe distance.

c. If springs are charged, pull the manual close lever (6) by means of a lanyard from a safe distance.

d. For partially charged closing springs, should closing not occur upon pulling the manual close lever, continue charging until closing springs are completely charged (heard to snap) and by visual indicator (14), then pull manual close lever (6) by means of a lanyard from a safe distance.

CIRCUIT BREAKER REMOVAL (Drawout Type)

(See Figure 1)

a. Trip circuit breaker by any tripping means.

b. Open front compartment door.

c. Engage racking crank (13) in opening (17) and push drawout lever (15) down. Rotate racking crank counterclockwise until racking mechanism automatically stops at "TEST" position. Lower track extensions.

d. Repeat step "C" to rack circuit breaker to "DISCONNECT" position.

e. Depress drawout lever (15) and continue cranking counterclockwise as far as stops will allow. (Do not force beyond stops.)

f. Pull circuit breaker forward to fully extended position. (Should the circuit breaker be charged, closing springs will automatically be discharged at this point.)

g. Remove circuit breaker from tracks with lifting yoke, then raise tracks into compartment and close door.

MAINTENANCE AND ADJUSTMENTS

SAFETY NOTES

De-energize both primary and control circuits before making any inspections, adjustments or replacements of parts. Make certain breaker is open by observing indicator (5, Figure 1), and closing springs are not charged by observing indicator (14, Figure 1).

When it is necessary that the charging springs be charged, or the circuit breaker be closed, make sure to stay clear of operating parts.

Stationary breakers should be checked for operation with the control circuit energized and the primary power de-energized. Drawout breakers should be withdrawn to "TEST" position for checking the breaker operation. For further inspection, adjustments, cleaning or replacement of parts, the drawout circuit breaker should be withdrawn and moved to a suitable area.

Stationary breakers should likewise be removed, but, if removal is not possible, then the primary and control circuit sources MUST BE DE-ENERGIZED.

PERIODIC MAINTENANCE INSPECTION

The safety and successful functioning of the connected apparatus depends upon the proper operation of the circuit breaker. Therefore, it is recommended that a maintenance program be established that will provide for a periodic inspection of the circuit breaker after

250 no load or load current switching operations.

If 250 operations are not completed in the first year of service, the circuit breakers should be inspected regardless. The circuit breaker should also be inspected after a short circuit or severe overload interruption, regardless of time period or number of operations.

Where unusual service conditions, as covered by AN Standard C37.13, exist, it must be assumed that these conditions were considered at the time of order; that the equipment supplied was designed for the special application; and that an appropriate supplemental maintenance program has been developed. These maintenance instructions only cover circuit breakers used under the standard usual service conditions.

The inspection should include opening and closing the circuit breaker electrically and manually. The unit should be visually inspected for loose or damaged parts. Arc chutes, contacts and insulation structure should be inspected as described below.

ARC CHUTES

If the circuit breaker has a solid state overcurrent trip device, it is necessary to remove two 1/4" diameter screws fastening the solid state control assembly, so that the control assembly can be moved to permit removal of the arc chute.

a. Remove two arc chute mounting screws (3, Figure 1) and retainer molding (2). Lift arc chute (1) up and draw out.

b. Inspect for breakage to side moldings, center moldings, arc plates and liner plates. Check for presence of foreign particles such as chips of moldings and metal.

INSULATION STRUCTURE

Insulated parts should be checked for damage. Dust and dirt should be removed by air or wiped with a clean lintless cloth. Do not use any oil base solvents.

CONTACTS

a. Remove dirt or grease on contacts with a clean lintless cloth.

b. Discoloration of the main contacts does not necessarily indicate damage. However, this condition may be removed by opening and closing the circuit breaker under no-load conditions.

CONTACT PITTING

a. A moderate amount of pitting will not interfere with the operation of the arcing contacts.

Should it be necessary to dress the arcing contacts to remove small burrs, cover the mechanism with a cloth. Follow the contour of the contacts with light wipes of a fine file and do not attempt to eliminate pitting entirely. When finished, remove cloth and wipe off any remaining dirt or filings. Do not use emery cloth or the like for sanding contacts. The material deposits affect continuous current ability adversely.

b. Should the main contacts show more than moderate pitting, check the contact pressure.



CONTACT PRESSURE CHECK AND ADJUSTMENT

(See Figure 3)

FOR SAFETY: Keep clear of breaker parts during this operation.

a. Close the breaker. Lever (15, Figure 1) must be in the up position.

b. For each set of eight contacts on one pole, the smallest gap "A" should be .090-.095 inch. If adjustment is required, loosen lock screw (2). Turn adjustment screw (1) until .090-.095 is obtained on the smallest gap of the eight contacts. Repeat this for the other two poles.

c. Slow close the breaker (see "Manual Slow Close to Check Contact Pressure" below) until the first arcing contact of the three poles just touches and hold in this position. Adjust the other two poles, screw (1), until the leading arcing contacts of each pole make simultaneously within 1/32 inch.

Tighten lock screw (2).

MANUAL SLOW CLOSE TO CHECK CONTACT PRESSURE

(See Figures 1, 3 and 4)

a. Remove arc chutes (1).

b. If the circuit breaker closing springs are discharged as seen by the spring charged indicator (14), engage the manual charge handle (12) with the charg-

ing lever (7). Pump charging lever until the circuit breaker closing springs are heard to snap into the charged position.

c. Remove screw (19), shift the shutter (4) to the left and insert the spring retainer bracket (11) so that its tips fit into the closing springs and its flanges fit into the holes in the closing spring guides.

NOTE: On drawout breakers, shutter (4) cannot be opened unless breaker drawout mechanism is in the "DISCONNECT", "TEST" or "CONNECTED" position. The drawout lever (15) cannot be operated when shutter (4) is open.

d. Use a stick to hold the spring retainer bracket (11) toward the front of the breaker and in place while pulling the manual close lever (6) to discharge the closing springs. (This will partially close contacts.)

e. Insert the manual charge handle (12) into the charging lever socket and pump to slow close the circuit breaker to the required amount.

f. To remove the spring retainer bracket (11), push the manual trip button (8) to trip the circuit breaker. Continue pumping until closing springs are again heard to snap. Then remove spring retainer bracket.

g. The circuit breaker is now charged and ready to be closed.

h. To discharge closing springs, pull the manual close lever (6) and push manual trip button (8).

i. Put arc chutes (1) back on.

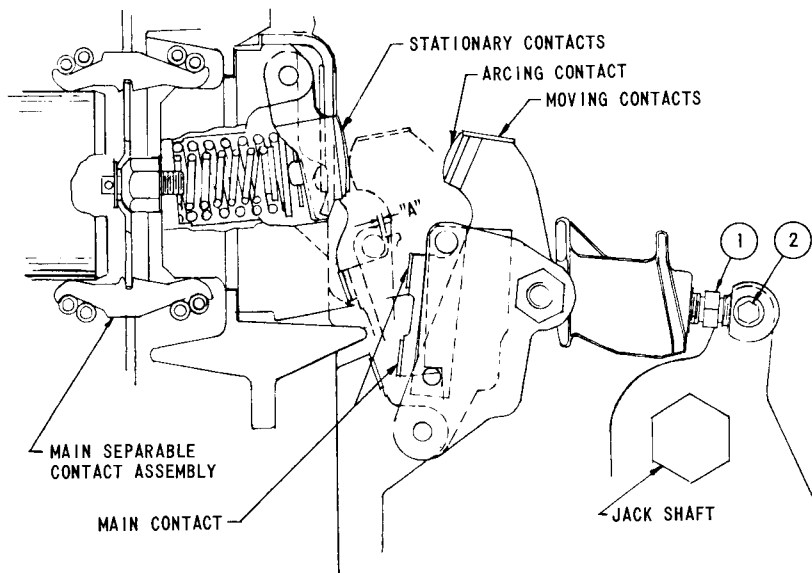

Fig. 3 — Contact Pressure Check and Adjustment

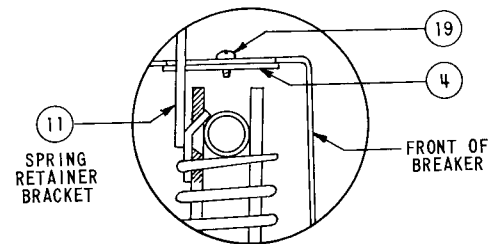

Fig. 4 — Shutter Detail

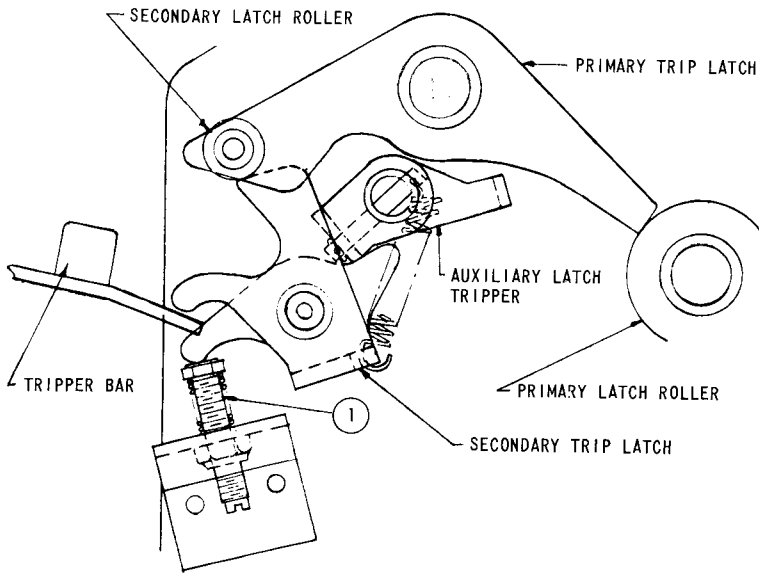

Fig. 5 — Primary Trip Latch Adjustment

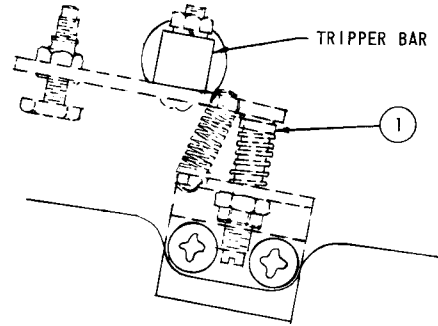

Fig. 6 — Tripper Bar Tripper Adjustment

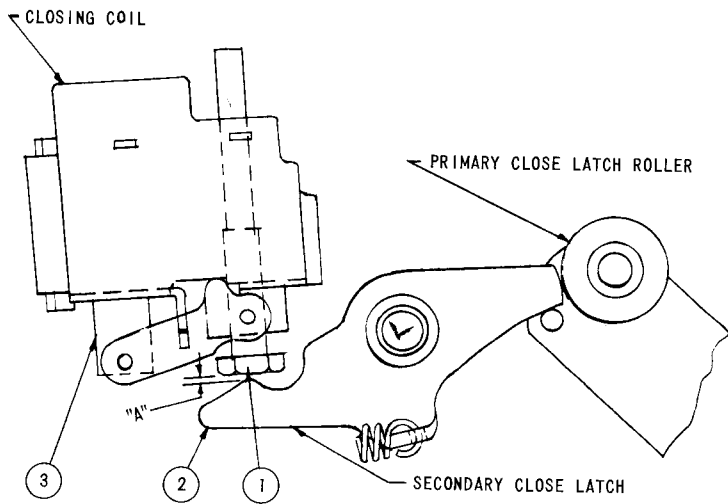

Fig. 7 — Primary Close Latch Adjustment

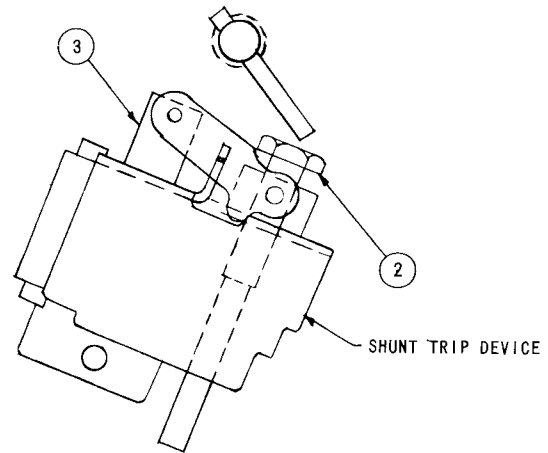

Fig. 8 — Shunt Trip Device Adjustment



OPERATING MECHANISM

The circuit breaker mechanism is adjusted at the factory for correct operation and should not be disturbed unless necessary.

FOR SAFETY: Keep hands clear of all moving parts. Serious injuries can result if a person comes in contact with breaker parts when the breaker is being opened or closed, or closing springs are being charged or discharged. Use extension tools for manipulating breaker parts.

If field testing indicates breaker malfunction, the following items may be checked.

Primary Trip Latch

Figure 5 shows the arrangement necessary for the breaker to be in the closed position. The spring holds the secondary trip latch down against screw (1). The secondary trip latch holds the secondary latch roller up, which in turn holds the opposite end of the primary trip latch down. This prevents the primary latch roller from moving to the left and opening the breaker. If none of the various trip devices are acting on the tripper bar or the auxiliary latch tripper to open the breaker or to prevent the breaker from closing and the breaker still will not close, then the following adjustment should be made.

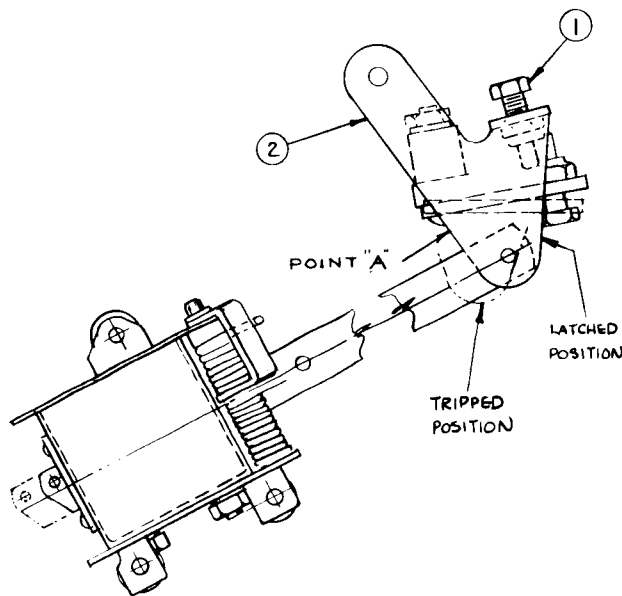

**Fig. 9 — Magnetic Latch Trip Adjustment
Type K-3000S and K-4000S Circuit Breakers**

a. Turn screw (1) down to insure that secondary trip latch will hold the secondary latch roller up.

b. With the breaker closed, turn up on screw (1) until the breaker trips.

c. Turn screw (1) down two turns.

Tripper Bar Adjustment (Figure 6)

To insure that tripper bar and tripper is in the correct position with the secondary trip latch, check and adjust as follows:

a. Turn screw (1) down to make certain the tripper will not trip out the breaker.

b. With breaker closed, turn screw (1) up until the breaker trips.

c. Turn screw (1) down 2 3/4 turns.

Primary Close Latch (See Figure 7)

a. With the circuit breaker closing springs charged and breaker contacts opened, the closing plunger (3) in de-energized position, there should be a 1/16" air gap between the rod (1) and the secondary latch (2) at point "A". Turn rod (1) for 1/16" dimension.

Shunt Trip Device (See Figure 8)

a. Turn trip rod (2) down until circuit breaker does not trip with plunger (3) held down.

b. Close circuit breaker.

c. Push plunger (3) down as far as possible and hold in this position while turning up trip rod (2) until circuit breaker just trips.

d. Turn rod (2) up 2 1/2 to 3 turns.

**Magnetic Latch Device (Type K-3000S, K-4000S)
Trip Adjustment (Refer to Figure 9)**

1. Turn adjusting screw (1) out as far as possible so that the circuit breaker will not trip when the magnetic latch trips.

2. Remove the terminal block cover on the solid state assembly by removing two lower screws (Fig. 12). Disconnect two wires at terminals 15 and 16.

3. Close the circuit breaker.

4. While lightly pushing at point "A" so that the lever (2) does not move through its full stroke and trip the circuit breaker, momentarily apply the voltage (3 V) from two dry cell batteries, size "D", to the two wires (+ to wire 16, - to wire 15) that were disconnected in operation 2. The magnetic latch should trip.

5. Gradually release the hold on lever (2).

6. While holding the lever (2) in the tripped position, turn in on screw (1) until the circuit breaker just trips, then turn in one additional turn.

7. Replace wires 15 and 16 and the terminal block cover.



**ELECTRO-MECHANICAL
OVERCURRENT TRIP DEVICE ADJUSTMENTS**

Short Time Delay Adjustment (See Figure 11)
(OD Types 400, 500, 900, 1000).

Push the short time lever to rear of breaker and slide the lever to the desired band. Make sure the lever pin drops into the pin hole.

Long Time Delay Band Adjustment (Figure 10)
(OD Types 400, 500, 600).

To reset long time delay to a different band, first loosen the locking screw for long-time delay adjustment approximately one turn. Turn the adjusting knob until the pointer lines up with the desired line marked "Minimum Time", "Instantaneous Time" or "Maximum Time". Retighten the locking screw.

NOTE: OD-300 has only one long-time delay setting; therefore resetting is not required.

Pick-Up Setting Adjustments (Figure 10)

Pick-up settings may be changed by turning the appropriate adjusting screw until the moving indicator lines

up with the desired pick-up point line.

NOTE: The top line corresponds to the top pick-up point, the second line from the top corresponds to the second pick-up point from the top, etc.

Armature Trip Travel Adjustment

CAUTION: Keep hands clear of all moving parts. The circuit breaker will trip to the "OPEN" position while checking or adjusting the armature trip travel.

The overload device trip travel is set at the factory; however, if trip travel readjustment is required due to replacement of overloads or other parts, then readjust as follows:

- a. (See Figure 10.) Back out on the two trip adjusting screws until the screws are engaging the nut by approximately two turns.
- b. Charge springs and close circuit breaker.
- c. Using a one foot long (approximate) stick, push up on long time armature, thick armature at point "A", and hold it tight against the magnet. Turn in screw marked "Right" until the breaker just trips. Continue to turn the screw in an additional 1 1/2 turns.

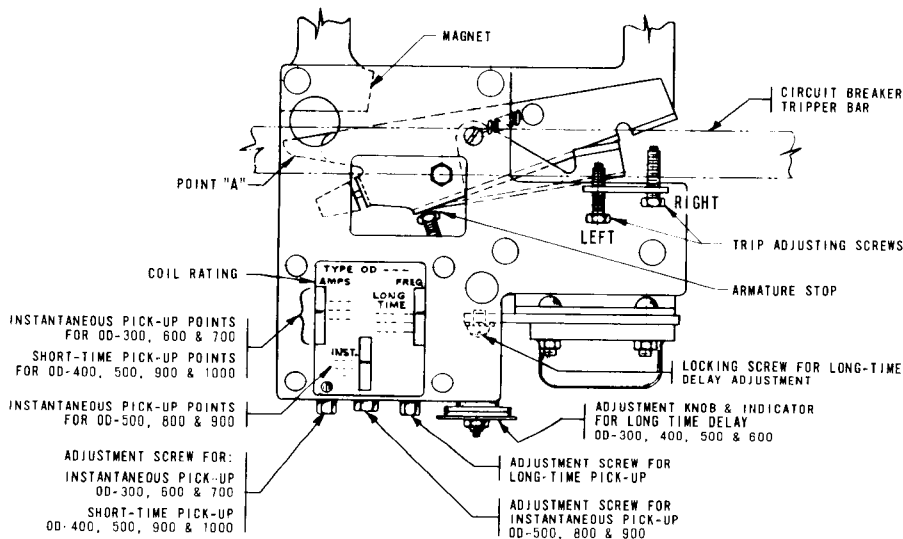

Fig. 10 — Overload Device Adjustments

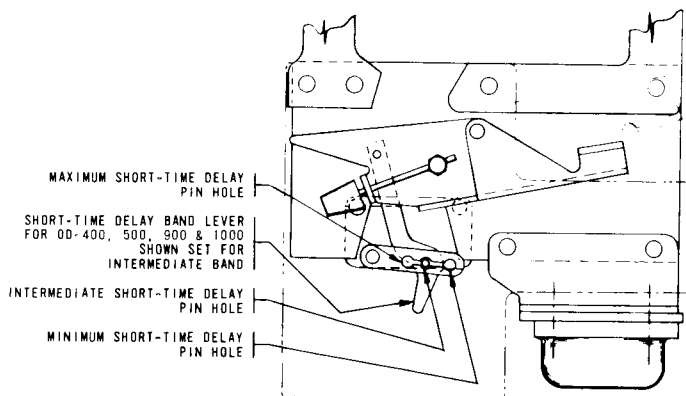

Fig. 11 — Short-Time Delay Band Adjustments



d. Charge springs and close circuit breaker. Push up on the thin armature and adjust the screw marked "Left" using the same procedure as "c" above.

e. Readjust the trip travel at the other two poles using the same procedure (steps a through d).

Field Testing of Electro-Mechanical Overcurrent Trip Devices

Refer to I-T-E Test Procedure IB-9.1.7-5 for complete testing of devices.

SOLID STATE OVERCURRENT TRIP DEVICE SETTINGS (See Figure 12)

No adjustments are necessary in selecting trip settings on this trip device. The selector plugs (solid circle) allow flexibility in settings and may be moved from one plug tap to another, consistent, however, with the pickup and time band settings necessary for proper circuit protection. Make certain that the selector plugs are pushed in completely for proper operation. If a plug is left out or not secure, the affected element will trip at the minimum setting shown, for safety, but coordination will be affected.

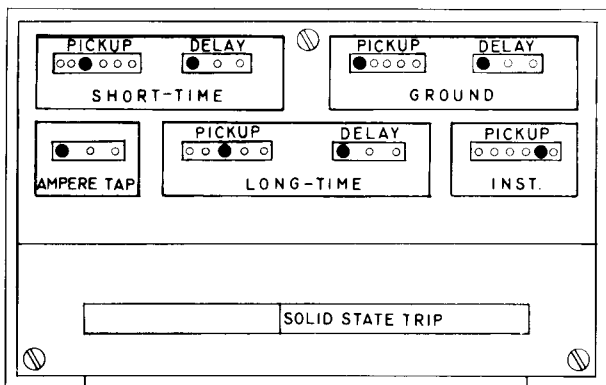

Fig. 12 — Solid State Overcurrent Trip Device Type SS-5G Shown

Field Testing of Solid State Overcurrent Trip Devices

Refer to I-T-E IB-9.1.7-21 for complete testing of these devices.

LUBRICATION

The K-line circuit breakers are lubricated during factory assembly as follows:

1. All mating surfaces of moving current-carrying joints have been lubricated with NO-OX-ID special Grade "A" grease manufactured by Dearborn Chemical Company.

2. All other mechanism parts, bearings, pins, etc. have been lubricated with NEBULA EP 5F manufactured by the Humble Oil and Refining Company.

The circuit breaker requires no lubrication during its normal service life. However, if the grease should become contaminated or if parts are replaced, any relubrication should be done with NO-OX-ID or NEBULA grease as applicable.

NOTES:

1. Do not use NO-OX-ID grease on any main and arcing contact surfaces.

2. It is recommended that the primary disconnects be maintained by renewing the NO-OX-ID grease during maintenance periods.

3. Do not use light oil to lubricate any mechanism parts.

4. Do not allow grease to be deposited on any latch roller surface during relubrication.

5. The charging motor is sealed and no lubrication is required.

6. DO NOT LUBRICATE OVERCURRENT TRIP DEVICES.

DIELECTRIC TEST

If the insulation has become contaminated, or routine tests are required, the test voltages to be applied for one minute to test the ability of the insulation to withstand overvoltages are as shown in Table 2 below.

It is not recommended that the motor be dielectric tested, but if desired, then test at 540 V ac or 760 V dc.

**TABLE 2
TEST VOLTAGES TO BE APPLIED FOR ONE MINUTE
TO TEST THE ABILITY OF THE INSULATION TO WITHSTAND OVERVOLTAGES**

	Breaker Open	Breaker Closed	Breaker Open or Closed
Breaker in Service or After Storage	1650 V ac -- 2300 V dc a. Between line and load terminals and metal parts normally grounded. b. Between line and load terminals	1650 V ac -- 2300 V dc a. Between terminals and metal parts normally grounded. b. Between phases.	1125 V ac -- 1600 V dc a. Between control circuit and metal parts normally grounded. NOTE: Motor must be disconnected from control circuit for this test.
After Short Circuit	1320 V ac -- 1860 V dc a and b as above	1320 V ac -- 1860 V dc a and b as above	900 V ac -- 1260 V dc a as above



On K-3000S and K-4000S circuit breakers, connect all sixteen terminals of the power shield solid state logic box together and to ground when conducting tests listed in Table 2. These terminals are located under the lower front cover of the logic box.

An additional dielectric test should be performed on K-3000S and K-4000S circuit breakers as follows: Connect all sixteen terminals of the power shield solid state logic box together and apply 500 V ac between the sixteen terminals and metal parts normally grounded.

ELECTRICAL CHARACTERISTICS OF CONTROL DEVICES

For closing and tripping currents, voltages and ranges, refer to Table 3 below.

For undervoltage trip devices, standard voltages and operating data, refer to Table 4 below.

Current values are average steady state values. Momentary inrush currents for all charging motors and ac coils are approximately 6-8 times these values.

RENEWAL PARTS

I-T-E recommends only those renewal parts be stocked that will be required to insure proper and timely maintenance for normal operation of the circuit breakers.

Refer to Renewal Parts Bulletin RP-9.1.8-2 for complete ordering information and Parts List. A copy of this bulletin will be furnished on request.

The minimum quantity of assemblies and items recommended in this bulletin is predicated on infrequent replacement of parts based on accumulated tests and operating experience. Total assemblies are recommended for fast replacement, when necessary, to return the breaker to service as quickly as possible. Then certain replaced assemblies, such as the stationary upper terminals, can be returned to the factory for nominal reconditioning. The bulletin contains specific part ordering instructions; and if desired, specific instructions regarding replacement of those part assemblies recommended, that are not obvious, are also available if ordered.

TABLE 3
ELECTRICAL CHARACTERISTICS OF CONTROL DEVICES
CLOSING AND TRIPPING CURRENTS, VOLTAGES AND RANGES

Type Breaker	Nominal Control Voltage	Average Closing Motor Current Amperes	Shunt Trip Current Amperes	Closing Relay Current Amperes		Closing Circuit Voltage Range	Shunt Trip Circuit Voltage Range	Recommended Control Fuse Size
				Anti-Pump	Release			
K-3000 K-4000 K-3000S K-4000S	115 V ac 60 cycle	10.	10.0	.15	4.0	95-125	50-125	10 A
	230 V ac 60 cycle	5.	1.84	.075	1.84	190-250	190-250	10 A
	48 V dc	25.	5.0	.11	5.0	35-40	28-60	15 A
	125 V dc	10.	2.0	.06	2.0	90-130	70-140	10 A
	250 V dc	5.	1.0	.03	1.0	180-260	140-280	10 A

TABLE 4
UNDervoltage TRIP DEVICE
STANDARD VOLTAGES AND OPERATING DATA

Service Voltage	Current at Rated Volts	Maximum Pickup Voltage	Dropout Voltage Range
115 V ac 60 cycle	0.5	92	35-69
230 V ac 60 cycle	0.2	184	69-138
480 V ac 60 cycle	0.1	384	144-288
48 V dc	0.32	38	14-29
125 V dc	0.2	100	38-75
250 V dc	0.1	200	75-150



ITE Imperial Corporation