

SIEMENS

Static Trip III

Information and Instruction Guide

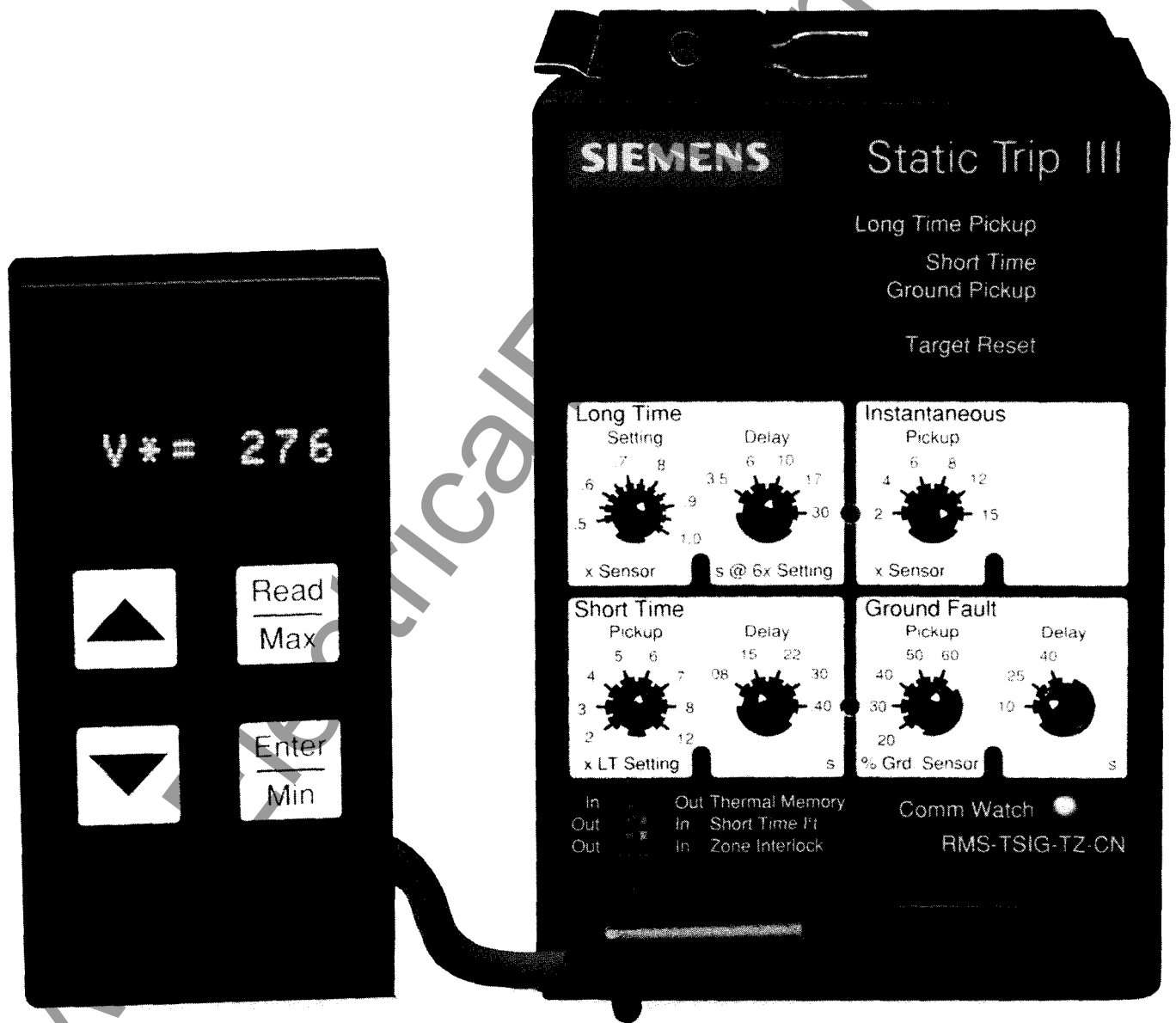



⚠ DANGER

Hazardous voltages and high-speed moving parts will cause severe personal injury and equipment damage.

Always de-energize and ground the equipment before maintenance. Maintenance should be performed only by qualified personnel. The use of unauthorized parts in the repair of the equipment or tampering by unqualified personnel will result in dangerous conditions which can cause severe personal injury or equipment damage. Follow all safety instructions contained herein.

IMPORTANT

The information contained herein is general in nature and not intended for specific application purposes. It does not relieve the user of responsibility to use sound practices in application, installation, operation, and maintenance of the equipment purchased. Siemens reserves the right to make changes in the specifications shown herein or to make improvements at any time without notice or obligations. Should a conflict arise between the general information contained in this publication and the contents of drawings or supplementary material or both, the latter shall take precedence.

QUALIFIED PERSONNEL

For the purpose of this manual a qualified person is one who is familiar with the installation, construction or operation of the equipment and the hazards involved. In addition, this person has the following qualifications:

- (a) **is trained and authorized** to de-energize, clear, ground, and tag circuits and equipment in accordance with established safety practices.
- (b) **is trained** in the proper care and use of protective equipment such as rubber gloves, hard hat, safety glasses or face shields, flash clothing, etc., in accordance with established safety practices.
- (c) **is trained** in rendering first aid.

SUMMARY

These instructions do not purport to cover all details or variations in equipment, nor to provide for every possible contingency to be met in connection with installation, operation, or maintenance. Should further information be desired or should particular problems arise which are not covered sufficiently for the purchaser's purposes, the matter should be referred to the local sales office, listed on back of this instruction guide.

The contents of this instruction manual shall not become part of or modify any prior or existing agreement, commitment or relationship. The sales contract contains the entire obligation of Siemens Energy & Automation, Inc. The warranty contained in the contract between the parties is the sole warranty of Siemens Energy & Automation, Inc. Any statements contained herein do not create new warranties or modify the existing warranty.

Table of Contents

General Information	1-4	Phase Sensor Rating	27
Introduction	2	Ground Sensor Rating	27
Overcurrent Protection Configurations	3	Phase Rotation	27
LCD Targets	3	Volts Source	27
Communications and Metering Functions	3	Volts Scale	27
Extended Protective Relaying	3	Volts Mode	27
Logging Functions	4	kW Demand Period and Number of Periods	27
Alarm Output	4	Comm Trip	27
Remote Open/Close/Trip	4	Comm Close	27
Functional Characteristics Summary	4	Comm Open	27-28
Principles of Operation	5-7	Default Values	28
Functional Circuit Description	5	Source for Configuration Parameters	28
User Control	6	Static Trip IIIC Rear Connectors	28
Current Sensors	6	Ten-Position Rear Connector	28
Protective Fault Operation	6	Four-Position Rear Connector	28
Tripping Actuator	6	Programmable Settings Integrity Protection	28
External Power Supply	7	Testing	29-35
PT Module	7	General	29
BDU Breaker Display Unit	7	Secondary Current Testing	29
Isolated Input/Output	7	Test Connections	29
Shadow Protection	7	Long Time Pickup Test	29-30
Installation and Adjustments Instructions	8-17	Short Time Pickup Test	30
Installing and Removing the Trip Unit	8	Instantaneous Trip Test	30
Removing and Replacing Trip Unit Cover	9	Ground Pickup Test	30
Setting the Overcurrent Protection Adjustments	9	Long Time Delay Test	30
Trip Unit Current Shaping Adjustments Curve	10	Thermal Memory Test	31
Long Time Fault Protection	11	Short Time Delay Test	31
Long Time Setting	11	Ground Time Delay Test	31
Long Time Delay	12	Zone Interlock Test	31
Thermal Memory	12	Load Indicator Output Test	32
Short Time Pickup	13	Tripping Actuator Test	32
Short Time Delay	13-14	Current Sensor Test	32
Instantaneous Fault Protection	14	Connections	32
Instantaneous Pickup	14	Continuity Checks	32
Ground Fault Protection	15	Excitation Test	33
Ground Fault Pickup	15	Sensor Polarity	33
Ground Fault Delay	16	Primary Current Testing	33-34
Ground Fault Memory Circuit	16	High Potential and Megger Testing	35
Constructing a Time-Current Curve	16-17	Breaker Display Unit	36-43
Ground Fault Sensing Diagrams	18	Breaker Display Unit	36
Current Sensor Wiring Diagrams	19	Selecting Operating Mode	36
Zone Interlocking	20	Data Mode	36
Metering and Extended Protective Relaying	21-28	Reading Metering Data	36
Measured Parameters Specifications	21-22	Reading Maximum and Minimum Values	37
Power Flow Sign Conventions	22	Reading the Alarm (ALRM) Log	37
Extended Protective Relaying Functions	22	Reading the Trip Log	38
Current Unbalance	22	Program Mode	38
Voltage Unbalance	23	Entering the Password	38
Under Voltage	23	Changing the Password	39
Over Voltage	23	Viewing Configuration Parameters and Set-Points	40
Under Frequency	23	Setting Configuration Parameters and Set-Points	41
Over Frequency	23	Clearing Min/Max and kWhr/kVARhr Values	42
Reverse Power	24	LED Display Brightness Control	42
Trip Log	24	BDU Self-Test Function	42
Trip Log Stored Parameters	24	BDU Error Messages	43
Alarm Functions	24-25	Accessories	44-46
Over Range Alarms	25	Zone Interlocking Components	44
Under Range Alarms	25	Zone Interlock Expanders	44
Unbalance Alarms	25	Zone Interlock Coupler	44
Power Factor Alarm	25	Sealable Transparent Cover	44
Power Factor Scale	26	Power Supplies	45
Event Log	26	Portable Test Set - Type PTS4	45
Alarm Log	26	Communications Secondary Disconnects	45
Recalibrating and Reprogramming	26	Breaker Position Switch	46
Password Protection	26	Interposing Relay	46
Remote Monitoring and Programming	26	Potential Transformers	46
Local Monitoring and Programming	26	Ordering Information	47-49
Fundamental Configuration Parameters	27	Current Sensor and Accessory Part Numbers	47
Address	27	Static Trip III Part Number Designations	48
Baud Rate	27	Trip Unit Catalog Number Definitions	49

General Information

Introduction

The trip units of the Static Trip III family are microprocessor controlled overcurrent protection devices for application with Siemens Type RL series of low voltage power circuit breakers as well as other manufacturer's circuit breakers. In addition to the basic overcurrent protection functions, Static Trip III trip units have a full complement of standard and optional features. Included in these features are serial communications, energy monitoring, and additional protective relaying functions. This full-features capability together with programmable flexibility allows for the easy adaptation of new and changing protection requirements.

A standard feature on all trip units is RMS current sensing. As opposed to peak-current sensing, RMS sensing measures the true heating potential of the current waveform. This allows for more accurate overcurrent protection and eliminates

nuisance tripping due to harmonic distortion of the current waveform.

There are four basic models of the trip units. All models are interchangeable on any frame rating of Siemens Type RL low voltage power circuit breakers.

- Static Trip III models provide basic overcurrent protection.
- Static Trip IIIIC versions provide the added capabilities of communications and current metering.
- Static Trip IIIICP devices have full power metering.
- Static Trip IIIICPX trip units have extended protective relaying capabilities.

Static Trip III trip units are also available with a universal mounting package for retrofit applications. The trip units may be used to retrofit the low voltage circuit breakers of almost every switchgear manufacturer.

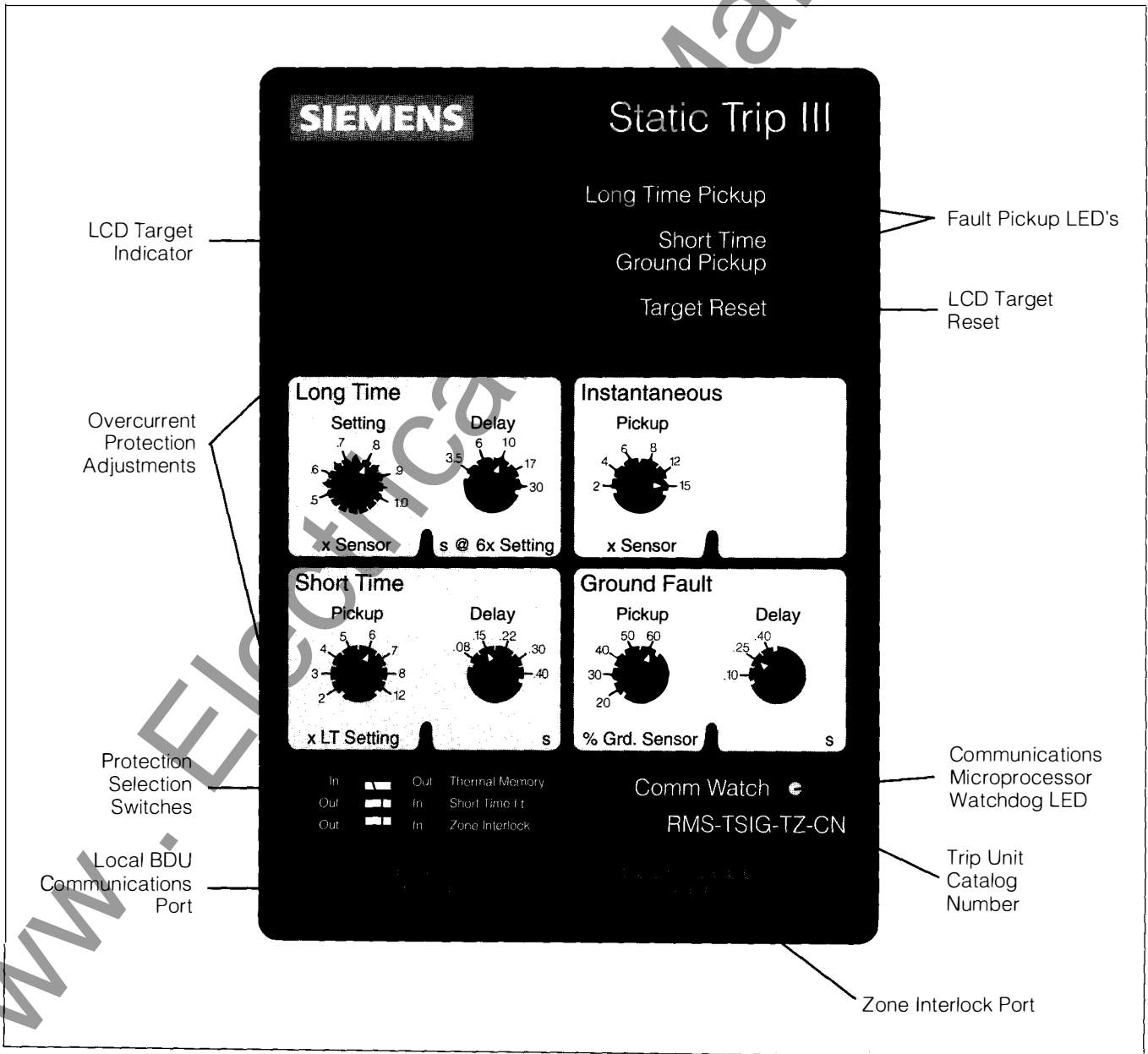

General Information

Overcurrent Protection Configurations

Static Trip III trip units are available in six basic overcurrent protection configurations to meet specific protection requirements. All trip units have Long Time fault protection with switchable thermal memory. This is designated by the suffix identifier T immediately following the letters RMS in the catalog number designation. All trip units include the LCD target indicator and fault pickup LED's. The "-T" suffix after the basic overcurrent protection identifier shows the LCD target is provided. Zone interlocking capability is also standard on trip units with short time or ground fault protection, but additional components and wiring are required to connect trip units together into a functioning zone-interlocked system. The "Z" suffix indicates zone interlocking capability. Available protection configurations are:

Protection Configuration

Long Time/Instantaneous
 Long Time/Short Time
 Long Time/Short Time/Instantaneous
 Long Time/Instantaneous/Ground Fault
 Long Time/Short Time/Ground Fault
 Long Time/Short Time/Instantaneous/
 Ground Fault

Identifier

RMS-TI-T
 RMS-TS-TZ
 RMS-TSI-TZ
 RMS-TIG-TZ
 RMS-TSG-TZ
 RMS-TSIG-TZ

LCD Targets

A custom liquid crystal display (LCD) provides a visual indication of an overcurrent tripping action. Target retention is provided by capacitive stored energy in the trip unit, eliminating the need for batteries. In addition to the tripping information, improper operation of the protection microprocessor is displayed on the LCD. The displayed legends are:

- OVERLOAD - long time delay tripping
- SHORT CIRCUIT - short time delay or instantaneous tripping
- GROUND FAULT - ground fault delay tripping
- DISABLED - watchdog circuit indicates protection microprocessor not functioning properly

Communications and Metering Functions

Static Trip IIIC trip units meter and communicate phase currents; Static Trip IIICP trip units meter and communicate currents, voltages, power, and energy information. Neutral and ground current metering is available on both models. (See table for list of parameters measured.)

A second microprocessor, referred to as the communications microprocessor, is used in these trip units to implement the communications and metering functions. A green "Comm Watch" LED, visible from the front of the trip unit, provides a visual indication of the operation of the second microprocessor. When the control power is present and the microprocessor is passing the built-in test routine, the LED blinks with a half-second pulse every three seconds. A burst of pulses also occurs whenever the trip unit is communicating to a master device via the RS-485 port at the back of the unit.

The same current sensors, used in the overcurrent protection function, are used in the current metering function. Special purpose Potential Transformer (PT) modules are used in measuring the voltages, (see Accessories section). The accuracy of the integrated digital metering functions is comparable to separate traditional analog instrumentation.

Metering Functions		
Measured Parameters	Model	
	IIIC	IIICP
Phase Current	•	•
Avg. Phase Currents	•	•
Ground Current ①	•	•
Neutral Current ②	opt	opt
Phase Voltages ③		•
Avg. Phase Voltage ③		•
Line Voltages		•
Avg. Line Voltage		•
kW		•
kW Demand		•
kW Hours		•
kW Hours Reverse		•
kVA		•
kVAR		•
kVAR Hours		•
Power Factor		•
Frequency		•

① Included when ground fault protection specified

② Requires "N" option and neutral current sensor

③ Only displayed for four wire systems

Two communications ports are available from which to read the metered data. A port on the front of the trip unit provides access for local monitoring with the Siemens BDU Breaker Display Unit, (see Breaker Display Unit section). A port on the back of the trip unit allows the trip unit to be integrated into the Siemens ACCESS™ electrical distribution communication system. The metered data can be displayed at a Power Monitor™ panel or personal computer. Network communications are over a shielded twisted pair data bus, SEABus. The real-time clock in the trip unit is periodically synchronized with a master clock in the network for accurate, to the second, time stamping of events.

Extended Protective Relaying

Static Trip IIICPX trip units provide the same overcurrent protection, communications, and metering as the Static Trip IIICP model plus seven additional protective relaying functions. The protection functions have independent pickup thresholds and delays. The pickup and delay set-points may be accessed and set remotely via the communications bus or locally via the BDU Breaker Display Unit, (see Breaker Display Unit section). Adjusting of the set-points is protected by a password to prevent their being changed by unauthorized personnel. Viewing of the set-point values is unprotected.

General Information

Static Trip IIIC/CP/CPX Protective Relay Functions		
Protective Function	Pickup Setting Range (SET=)	Time Delay Range (DLY=)
Current Unbalance	5-50%	1-15 seconds
Voltage Unbalance	5-50%	1-15 seconds
Overvoltage	60-660V	1-15 seconds
Undervoltage	60-660V	1-15 seconds
Reverse Power	10-2000kW	1-15 seconds
Overfrequency	50-70Hz	1-15 seconds
Underfrequency	45-60Hz	1-15 seconds

Logging Functions

Static Trip IIIC/CP/CPX model trip units include several logging functions for recording tripping events, pickup conditions, alarm activity, and minimum and maximum measured values. All logged data is accessible via the communications bus. Most of the information can also be read using the BDU accessory. Accurate time-stamping of trip and event log data requires periodic synchronization via the communications bus using a master device such as the Power Monitor display and monitoring device. The logging capabilities with type of memory, accessibility, and time-stamp characteristics are summarized in the following table:

Logging Characteristic	Trip Log	Event Log	Alarm Log	Min/Max Log
Type of Memory ①	Non-volatile	Active	Active	Non-volatile
Information Stored	Last three tripping events	Approximately ten events ②	Last alarm relay activation	Min/Max for all real-time measured parameters
Time-Stamped at Trip Unit	Yes	Yes	No	No
Accessible Via: RS-485				
Comm. Port	Yes	Yes	No ④	Yes
Local BDU				
Comm. Port	Yes ③	No	Yes	Yes

- ① The non-volatile memory is EEPROM which requires no batteries and is unaffected by loss of control power. The active memory requires control power to maintain data.
- ② The actual number of events that may be recorded depends on memory required for each type of event. The nominal number of recorded events is ten. Events include pickup active and inactive, circuit breaker position change, alarm setpoint activation and release, and alarm relay activation. The most recent events are retained.
- ③ Only the most recent trip event is available to the BDU, without time-stamp information.
- ④ The Alarm Log information is a duplicate of the Event Log message associated with relay activation thereby providing a local readout of what caused the alarm relay to activate. This feature provides the flexibility to read all critical data from the trip unit when the RS-485 network communications capability is not being used or is not fully implemented by the master device.

Alarm Output

A standard feature on Static Trip IIIC/CP/CPX trip units is an alarm output. Any of the trip unit's measured parameters can be set to activate the output based on threshold and delay setpoints. Activation of the output is recorded in the trip unit's event log for remote signaling via the communications bus.

The trip unit alarm output is a solid state optically isolated 100mA 12V signal. An interposing relay is required to provide a 1A 120V ac/125V dc NO solid state contact for integration into alarm or control schemes (see Accessories section).

Remote Open/Close/Trip

Static Trip IIIC/CP/CPX trip units can be wired to open and/or close an electrically operated circuit breaker on command from a Power Monitor™ unit or other master device using the RS-485 communications port. The alarm output is used for the "open" command, thereby restricting use for other alarm functions. The "trip" command uses the tripping actuator to open the circuit breaker and requires no additional components or wiring. Note that if a bell alarm contact is installed on the circuit breaker, using the "trip" command may cause other unintended functions such as prevention of automatic throwover. Care should be taken to select either "open" or "trip" functions to meet the intended application. All open, close and trip communication commands are secure to prevent unintended operation, and can be disabled at the trip unit.

Functional Characteristics Summary

The functional characteristics of Static Trip III trip units are summarized in the following table. The catalog number designations on the front of the trip unit delineate the trip unit's characteristics. An explanation of the catalog number designation is given in the Ordering Information section.

Functions/Static Trip III Model	III	IIIC	IIICP	IIICPX
Self-Powered Overcurrent Protection	•	•	•	•
RMS Sensing	•	•	•	•
Switchable Thermal Memory	•	•	•	•
Ground Fault Protection	opt	opt	opt	opt
LCD Target	•	•	•	•
Protective Microprocessor Watchdog	•	•	•	•
Pickup LEDs	•	•	•	•
Zone Interlocking ①	opt	opt	opt	opt
Retrofit Universal Mounting Package	opt	opt	opt	opt
RS-485 Communications Port		•	•	•
Breaker Display Unit Port ②		•	•	•
Communications Microprocessor Watchdog		•	•	•
Comm Watch LED		•	•	•
Backup "Shadow" Protection		•	•	•
Trip Log		•	•	•
Alarm Relay Output ①		opt	opt	opt
Trip Unit Status Indication		•	•	•
Breaker Position Indication		•	•	•
Breaker Operation Counter		•	•	•
Communication Open/Close/Trip ①⑤		opt	opt	opt
Event Log		•	•	•
Phase Current Metering		•	•	•
Ground Current Metering ③		•	•	•
Neutral Current Metering ④		•	•	•
Min/Max Current Log		•	•	•
Power Metering Functions			•	•
Min/Max Power Log			•	•
Extended Protective Relaying			•	•
Extended Trip Log			•	•

- ① Requires additional wiring to meet specific application.
- ② Supports optional Breaker Display Unit accessory.
- ③ Included when ground fault protection specified
- ④ Requires "N" option and neutral current sensor.
- ⑤ Open command uses alarm relay output and restricts use for other alarm functions. Close command requires electrically operated breaker.

Principles of Operation

Functional Circuit Description

Static Trip III trip units use microprocessors to execute the numerical and logic operations of the fault protection, metering, and communications functions. The protection microprocessor and its associated memory circuits are totally dedicated

to the overcurrent fault protection functions. Trip units with communications capabilities have an additional microprocessor and memory which executes the communications, metering, and extended protection functions.

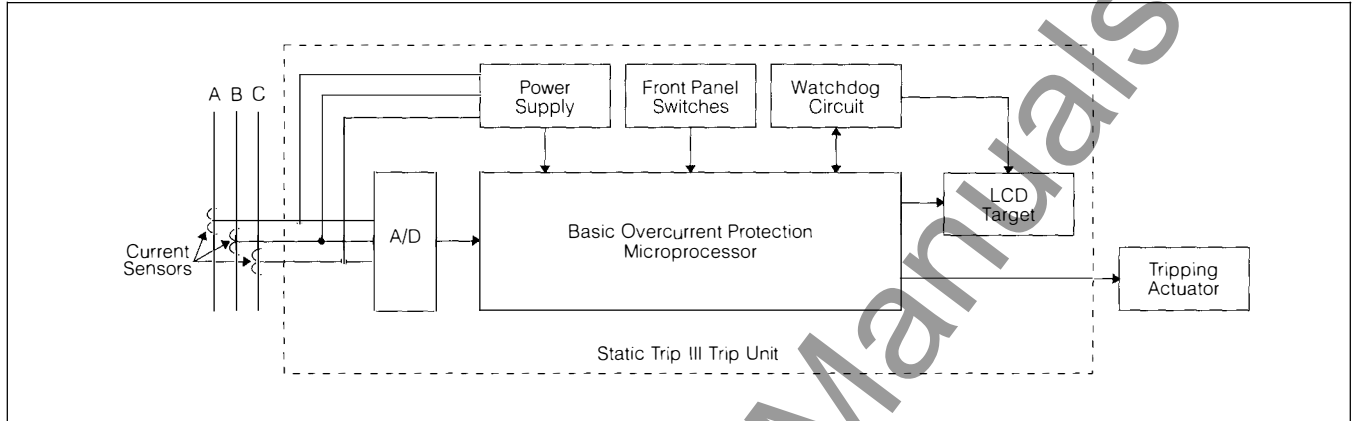

Static Trip III Tripping System Functional Block Diagram

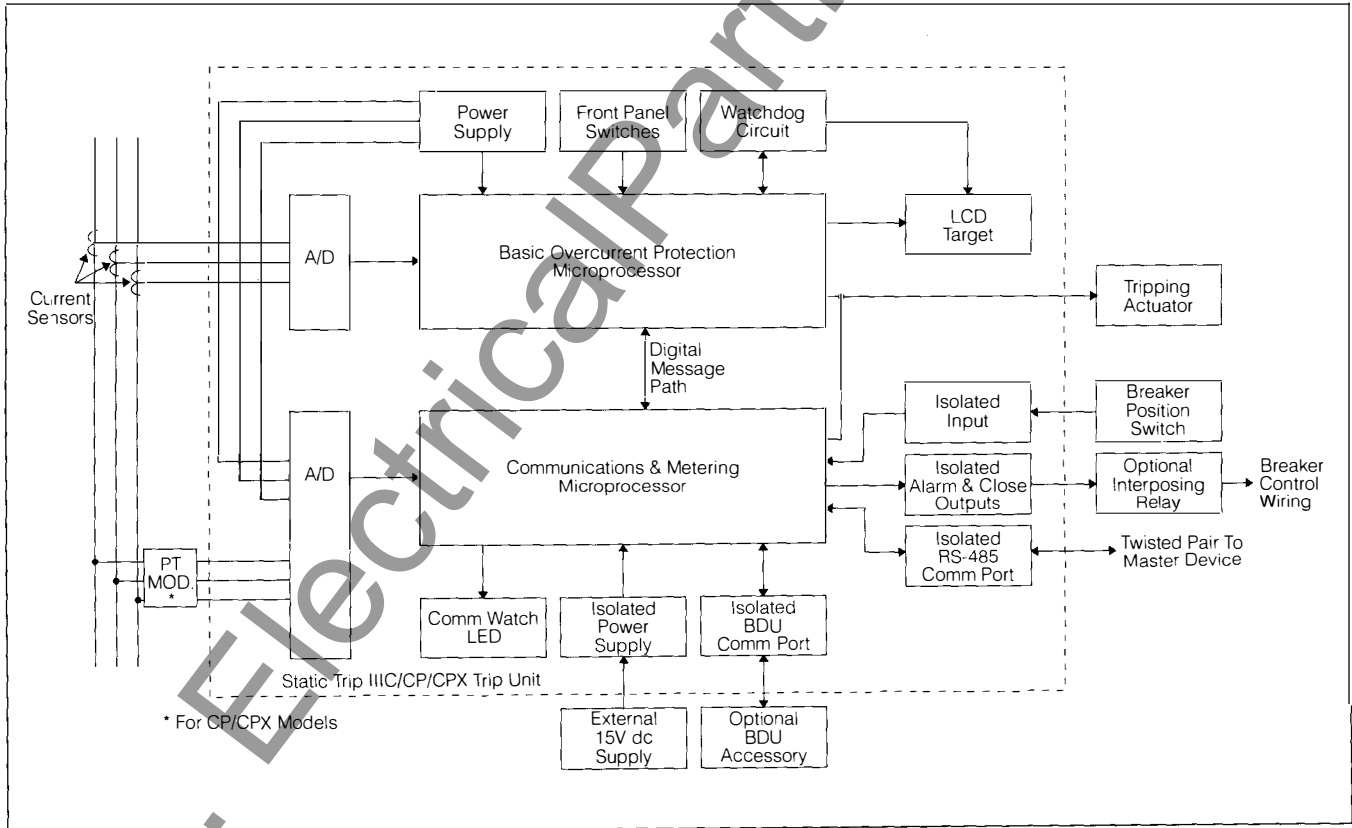

Static Trip IIIIC/CP/CPX Tripping System Functional Block Diagram

Principles of Operation

User Control

The adjustments and switches on the trip unit's face and the programming via the communications ports allow the user control of the trip unit. By these means the user selects the numerical values and software routines, stored in the memory circuits, that are to be used by the microprocessors in performing their functions. The selection and programming process has been designed to be straight forward and user friendly to the degree that the internal operation of the trip unit is totally transparent to the user.

Current Sensors

Current level data for fault protection and metering are derived from special purpose current sensors mounted in the circuit breaker. These current sensors are toroidal current transformers. As passive devices they provide high reliability with minimum signal error. The rated primary current of the sensors establish the maximum continuous current rating of the circuit breaker. The rated secondary current for the sensors is 0.5 amperes at rated primary current. All the sensors used with Static Trip III trip units are encapsulated in polymeric material to protect the windings and prevent motion during a short circuit fault condition.

The current sensors provide operating power as well as current level data. Therefore, when the circuit breaker is carrying load currents, Static Trip III trip units require no external connections or control power to perform their basic overcurrent protective functions.

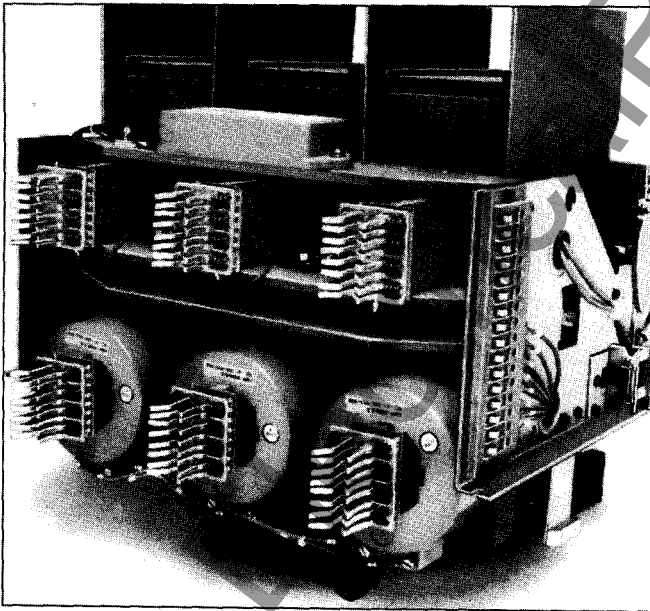

Current Sensors

Protective Fault Operation

The following is a brief description of the process for overcurrent fault protection. The process for the extended protective relaying functions is very similar.

The current signals from the sensors are converted to digital voltages by a resistor network and analog to digital converters (A/D's) in the trip unit. The digital voltages are stored in temporary memory and are used by the microprocessors in detecting and processing overcurrent conditions and in metering.

The protection microprocessor reads the temporarily stored digital voltages and compares their values with the set of values corresponding to the setting selected by the user. When an overcurrent condition is detected, the microprocessor's software begins to process the appropriate protection function. During the processing of the protection function, the microprocessor continues to monitor the incoming current level data. If the overcurrent condition continues until the processing is completed and the appropriate delay time has elapsed, a tripping command is issued by the microprocessor. The tripping command from the microprocessor causes an output signal to be sent to a coil in the tripping actuator.

Tripping Actuator

When the circuit breaker is closed, the tripping actuator is held in a charged position by a permanent magnet. The output signal from the trip unit energizes a coil inside the actuator causing the magnetic flux to shift to a new path. This releases the stored energy of a spring, also located inside the actuator, and trips the circuit breaker. When the circuit breaker mechanism opens, the actuator is automatically returned to the charged-and-held position by a reset mechanism. A second coil inside the tripping actuator is used to augment the holding power of the permanent magnet during high short circuit conditions so that stray magnetic fields will not cause unintended release or demagnetization while the trip unit is in short time delay (US Patent issued).

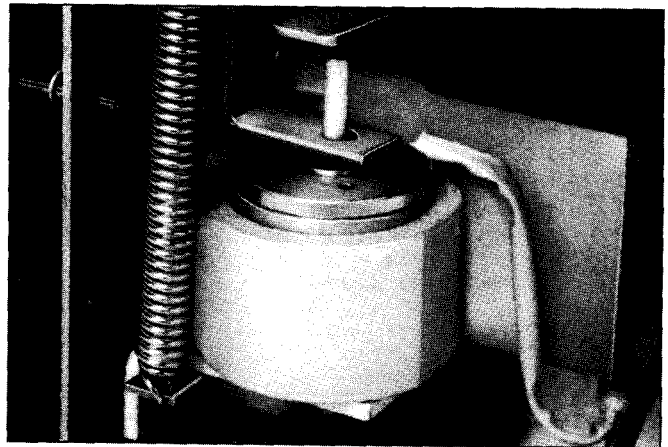

Tripping Actuator (bottom view)

Principles of Operation

External Power Supply

Static Trip IIIC/CP/CPX model trip units require external 15V dc control power for the communications microprocessor. This allows communication with the trip unit during all load current conditions, even with the circuit breaker switched off. Internal isolation prevents wiring faults from damaging the trip unit's protective circuits.

PT Module

A special purpose potential transformer assembly is used to supply voltage signals to Static Trip IIIC/CP/CPX model trip units and provide isolation from the primary circuits. Class CC 1A 600V fuses are used to protect against internal PT module faults. The PT modules are encapsulated in polymeric material to protect the transformer windings and withstand mechanical vibration when mounted directly on the circuit breaker. The PT module primary inputs are from the three phases plus neutral. For 3-wire systems, the neutral conductor input is not used.

BDU Breaker Display Unit

The BDU accessory provides a local means of reading data from and programming Static Trip IIIC/CP/CPX model trip units. It contains its own microprocessor which controls the display and communicates with the trip unit using the local BDU communication port. Power to operate the LED display and microprocessor circuitry is derived from the trip unit through this same port.

Isolated Input/Output

Input for a 52b breaker position switch and outputs for Alarm (output 1) and Close Breaker (output 2) are optically isolated to protect the trip unit's internal protection circuits from external wiring faults. These outputs are rated 100mA 12V and require an interposing relay to integrate these control signals into the desired breaker wiring.

Shadow Protection

The overcurrent protection functions are enhanced by the communications microprocessor. The protection microprocessor operates totally independent of the communications and metering functions. Should communications or metering processing fail, the protection functions will remain fully operational. However, the communications microprocessor is programmed to provide backup or "shadow" fault protection. The "shadow" protection curve is defined by pickup and delay values slightly above the highest available settings for Long Time and Short Time functions. In the unlikely event of a protection microprocessor failure, the communications microprocessor will execute the overcurrent protection functions.

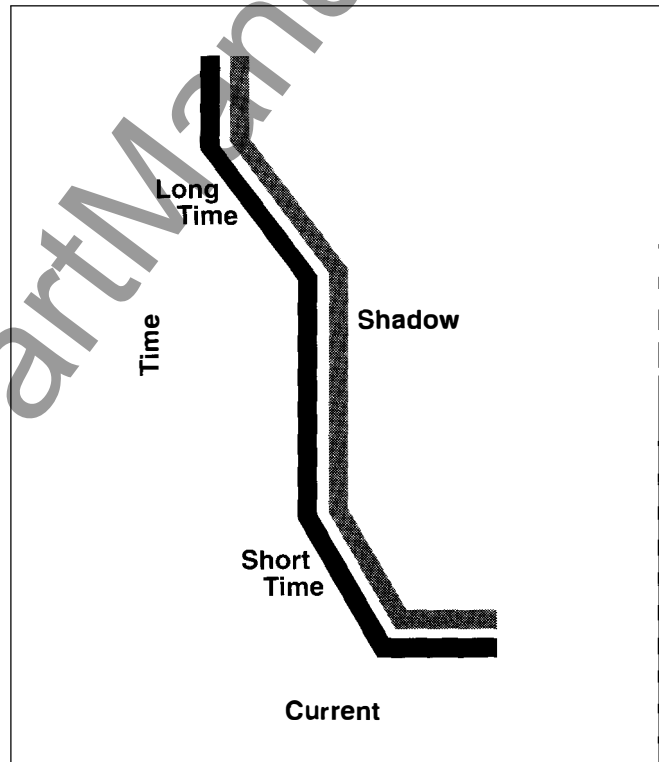

Shadow Protection

Installation and Adjustments Instructions



⚠ DANGER

Hazardous Voltage.
Will cause severe injury or death.

Turn power off and lock out supplying device before installing or removing trip unit.

Before installing or removing the trip unit, the circuit breaker should be placed in the open position with the mechanism discharged. Draw-out breakers should be in the disconnected position.

The Static Trip III trip unit mounts onto a slide-type bracket at the lower right side of Siemens Type RL circuit breakers. (Note that retrofit version trip unit does not include a slide bracket. Also, retrofit of standard trip unit to other manufacturer's breakers may use different locations.)

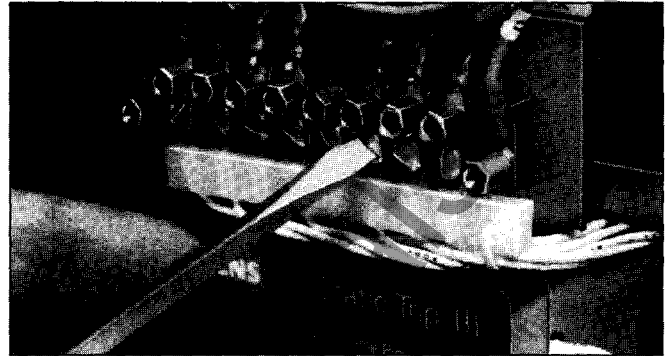

4.) Align the terminal block fanning strip with the terminal block and secure it with the eight (8) #6 - 32 slotted head screws.

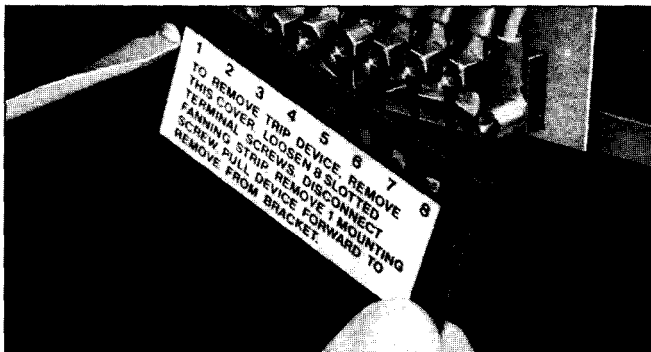

1.) Remove the terminal block cover.

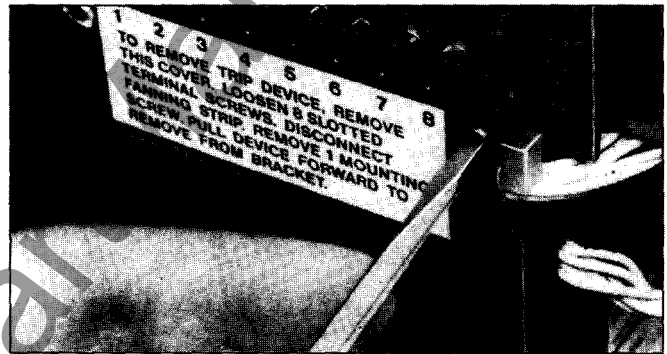

5.) Replace the terminal block cover.

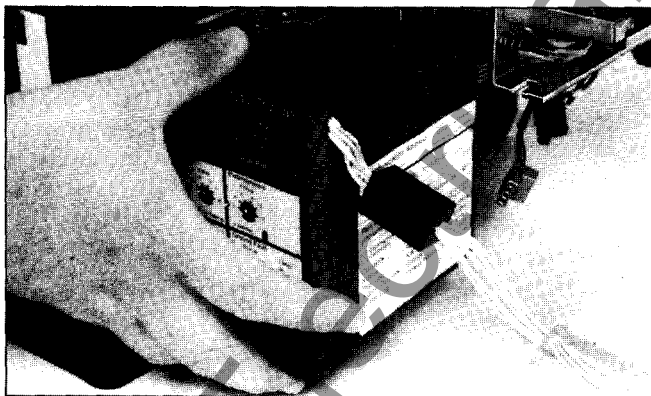

2.) Align the trip unit and slide it all the way onto the bracket.



6.) Insert the BDU and/or zone interlock cables at the front of the trip unit.

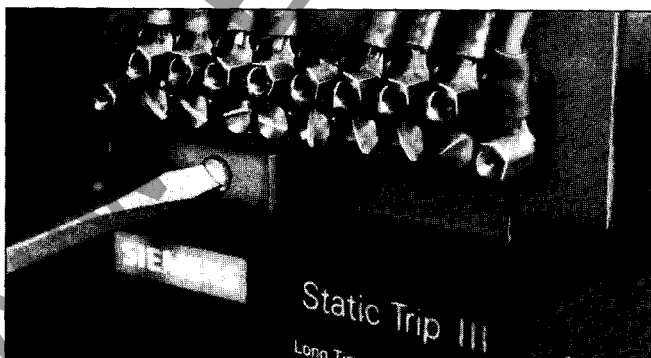

3.) Secure the trip unit with a single (1) #6 - 32 mounting screw.

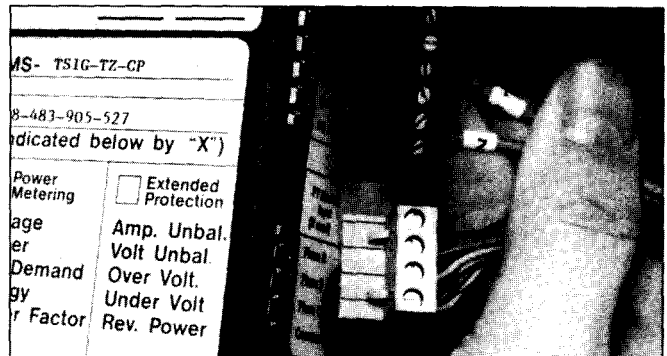

7.) Insert the appropriate communications and PT module connectors at the rear of the trip unit. Installation of the trip unit is now complete.

Use the reverse procedure to remove the trip unit from the circuit breaker.

Installation and Adjustments Instructions

Removing and Replacing the Trip Unit's Transparent Cover

The current protection adjustments on the front panel of the trip unit can be secured against tampering by a plexiglass transparent cover (see Accessories section).



1.) Prior to setting the adjustments, the transparent cover must be removed. All that is required to remove the cover is to remove the two nylon sealing screws that hold it in place.



2.) After the adjustments have been set to the desired positions, the cover should be replaced and a wire may be inserted.



3.) After inserting the wire, secure with a lead seal to prevent tampering.

Setting the Overcurrent Protection Adjustments

The trip unit executes its overcurrent protection functions based on the current sensor rating and the settings of the current protection adjustments. Therefore, care should be taken by the user to make proper sensor selection and adjustment settings.

NOTE: An adjustment will momentarily revert to its minimum possible setting whenever a change to the adjustment is being made. This may cause inadvertent tripping of the circuit breaker if the adjustment is made while the circuit breaker is carrying load current. Therefore, Siemens recommends that all adjustment changes be made with the circuit breaker open.

To set an adjustment, place a slotted screw driver onto the point-to-point adjustment switch and rotate the switch to the desired setting.

The figure on the following page describes the region of the time current curve that is being affected by each adjustment.

Installation and Adjustments Instructions

Trip Unit Current Shaping Adjustments

(This curve is for illustration purposes only)

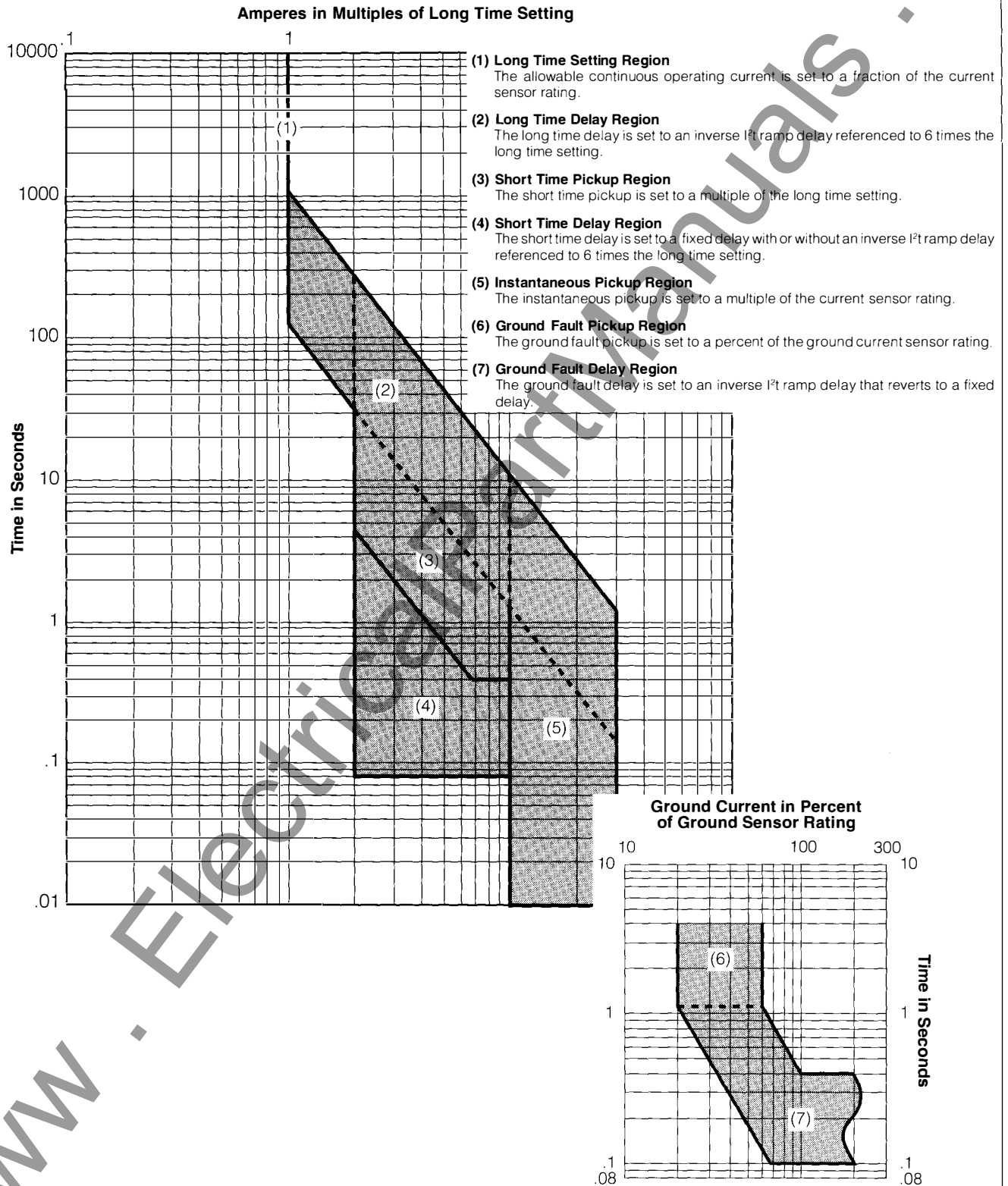

Installation and Adjustments Instructions

Long Time Fault Protection

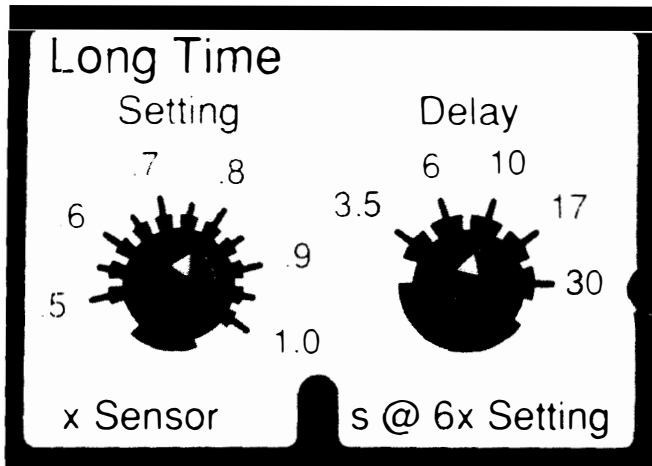

Long Time Setting

The long time setting establishes the maximum current level at which the circuit breaker will continuously operate without initiating a tripping sequence. With the setting switch, the continuous operating current level may be set to .5, .55, .6, .65, .7, .75, .8, .85, .9, .95, or 1.0 times the current sensor rating.

The variance in the tripping sequence pickup due to electronic components tolerances is less than 10%. The trip units are designed to accommodate this variance. The pickup is automatically set by the trip unit to a value that is 10% greater than the switch setting. Therefore, the actual pickup value will be between the switch setting and a value 20% greater than the switch settings. This ensures that the circuit breaker will operate continuously at a current corresponding to the switch setting.

On a Siemens Type RL circuit breaker, the current sensor rating is given on the circuit breaker rating label located directly above the trip unit. A similar sensor rating label should be found when retrofit to other manufacturer's circuit breakers.

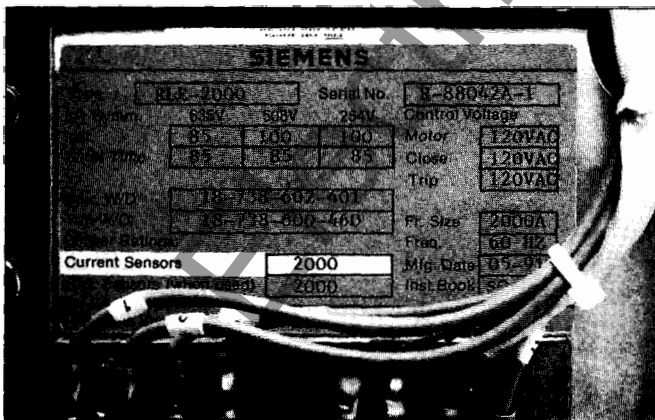

Circuit Breaker Rating Label

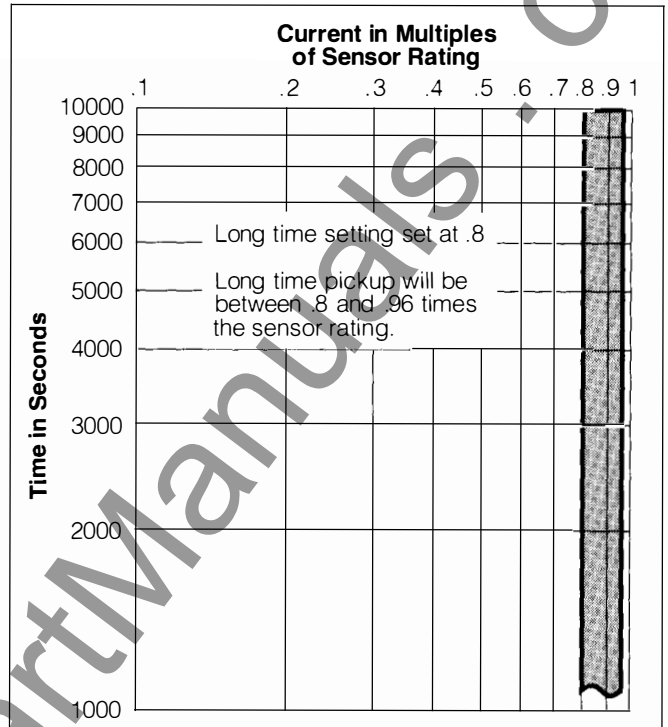

Example – Long Time Pickup
Refer to drawing 18-754-891-401 for accurate time current plot.

Installation and Adjustments Instructions

Long Time Delay

The long time delay sets the tripping delay of the trip unit based on the magnitude of the overcurrent condition. The setting of the long time delay selects one of five delay bands. The delay bands are inverse I^2t ramp functions. The I^2t delay provides a selective long time protection because the delay is inversely proportional to the square of the magnitude of the overcurrent condition. This means that higher overcurrent conditions have shorter delays and, conversely, lower overcurrent conditions have longer delays. The lower values of the selected band define the minimum delay for the initiation of the circuit breaker tripping. The upper values of the band define the maximum time for the clearing of the tripping action, including circuit breaker opening and arc quenching time. The lower value of the long time delay band is referenced to 3.5, 6, 10, 17, or 30 seconds at a current corresponding to 6 times the long time setting. Changing the long time setting changes the current to which the time delays are referenced.

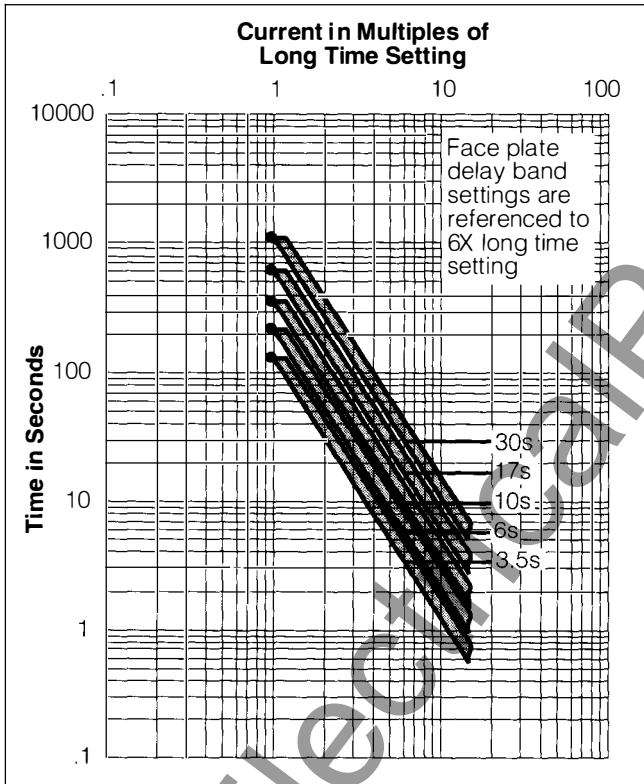

Example - Long Time Delay Bands
Refer to drawing 18-754-890-401 for accurate time current plot.

Thermal Memory

Included in the long time fault protection is a "Thermal Memory" function. The purpose of the "Thermal Memory" function is to protect against a persistent intermittent overcurrent condition. The function may be activated by placing the Thermal Memory switch, on the front of the trip unit, to the "In" position.

With the function activated, the long time delay counter does not immediately reset to zero when the current falls below the long time pickup value. Instead, it counts down at a rate determined by the magnitude of the remaining current. When there is a persistent intermittent overcurrent that does not reach the short time pickup level, the delay counts are accumulated. Tripping occurs when the accumulated value reaches the selected long time delay. In the special case where the current drops to nearly zero, the long time delay counter does reset to zero.

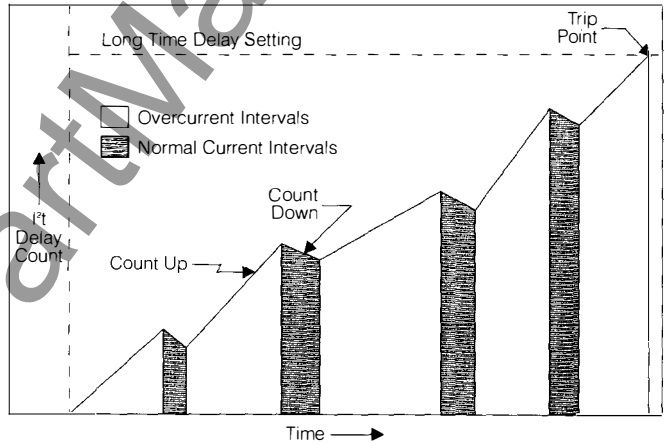

Thermal Memory protects against persistent intermittent overcurrents.

Short Time Fault Protection

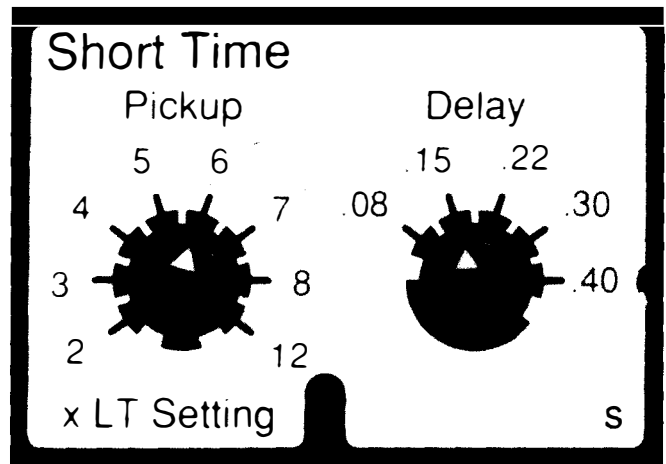

Installation and Adjustments Instructions

Short Time Pickup

The short time pickup sets the level of high current the circuit breaker is allowed to carry for a short period of time. This pickup, together with the short time delay, allows downstream circuit breakers time to clear short circuit faults without tripping the upstream circuit breakers. When the pickup level is exceeded, the trip unit initiates the short time fault protection tripping sequence. The short time pickup may be set to 2, 3, 4, 5, 6, 7, 8, or 12 times the long time setting. Changing the long time setting changes the short time pickup current level.

The short time pickup is also implemented to accommodate possible variances in the tripping sequence pickup value due to electronic components tolerances. The functional operation is the same as it is for the long time setting previously presented. The tolerance is plus 20%/minus 0%.

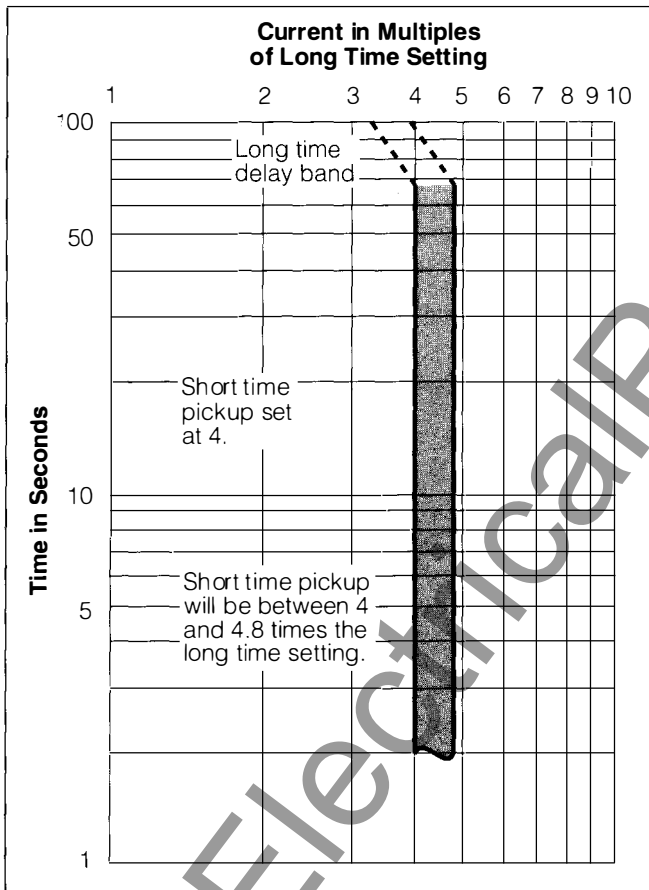

Example – Short Time Pickup
Refer to drawing 18-754-890-401 for accurate time current plot.

Short Time Delay

The short time delay sets the tripping delay of the trip unit in response to a current in excess of the short time pickup current level. The setting of the short time delay selects one of five fixed delay bands. The lower value of the selected band defines the minimum delay for the initiation of the circuit breaker tripping. The upper value of the band defines the maximum time for the clearing of the tripping action including circuit breaker opening and arc quenching time. The lower value of the short time delay band may be set to .08, .15, .22, .30, or .40 seconds.

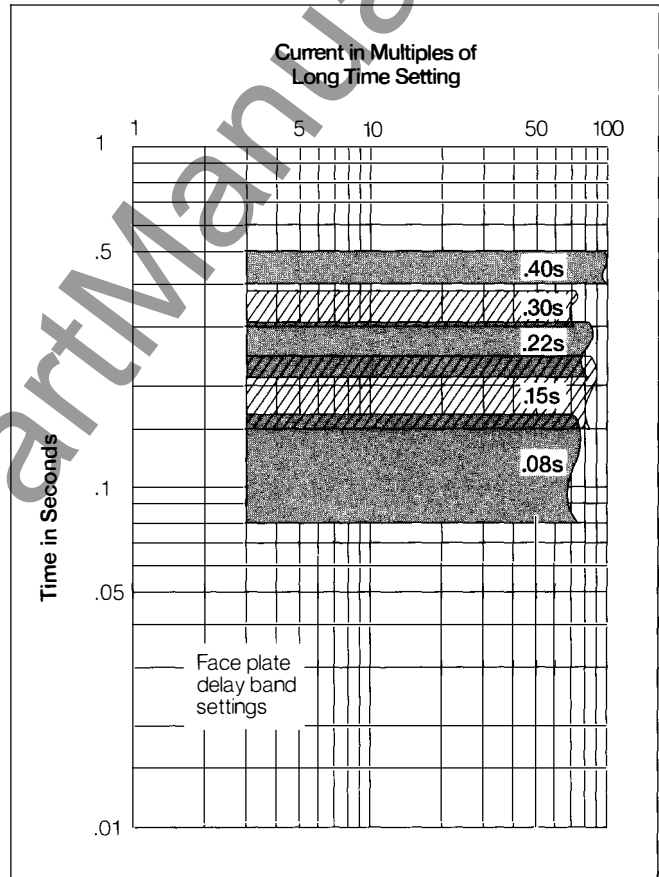

Example – Short Time Delay Bands (Fixed Delay)
Refer to drawing 18-754-890-401 for accurate time current plot.

Installation and Adjustments Instructions

A switch on the front of trip units with short time fault protection allows for the selection of an inverse I^2t ramp function short time delay. In some applications the I^2t delay allows for better coordination with downstream circuit breakers and fuses. The lower value of the I^2t delay band is preset to a calibrated value of .5 seconds at a current corresponding to 6 times the long time setting. Changing the long time setting changes the current at which the time delay is referenced. At higher currents the I^2t delay reverts to a fixed delay at the value selected with the short time delay switch.

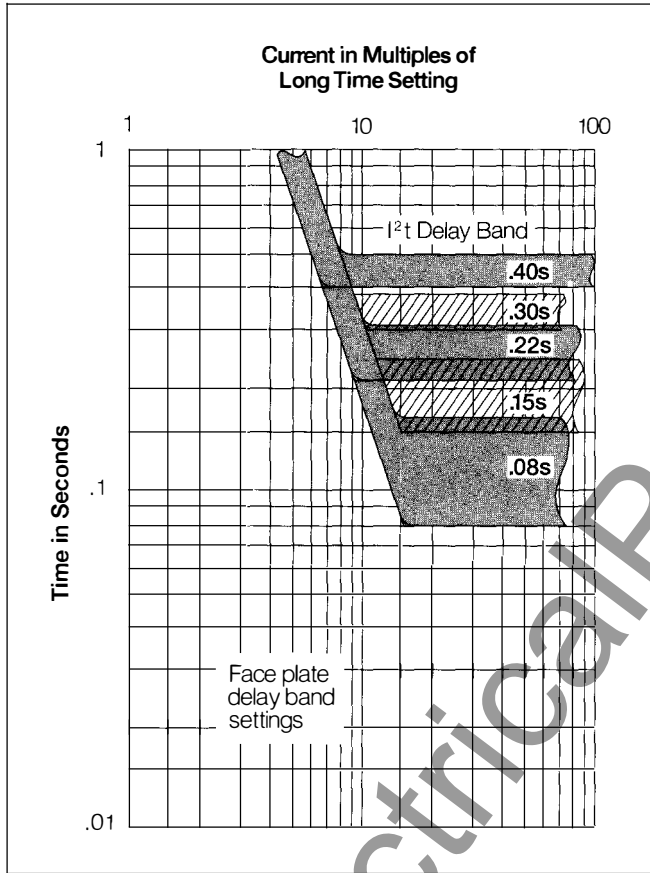

Example – Short Time Delay Bands with I^2t ramp delay
Refer to drawing 18-754-890-401 for accurate time current plot.

Instantaneous Fault Protection

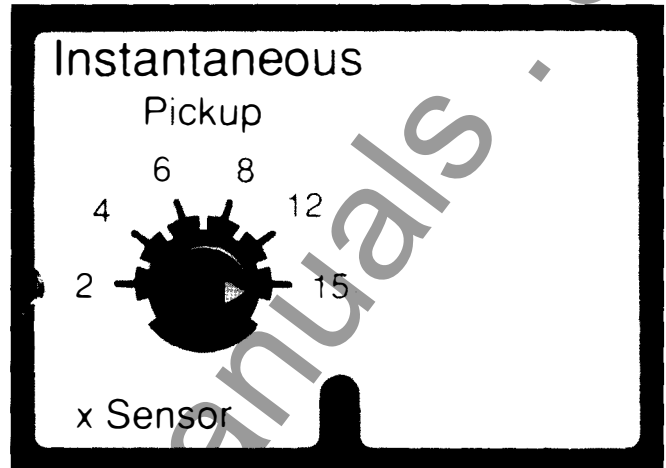

Instantaneous Pickup

The instantaneous pickup sets the level of high current at which the trip unit will trip the circuit breaker without an intentional time delay. Non-delayed tripping, in response to a severe overcurrent condition, minimizes potential damage to electrical systems and equipment. The instantaneous pickup may be set to 2, 4, 6, 8, 12, or 15 times the current sensor rating. The pickup is independent of the long time setting.

The tolerance on the instantaneous pickup is plus 20% / minus 0%.

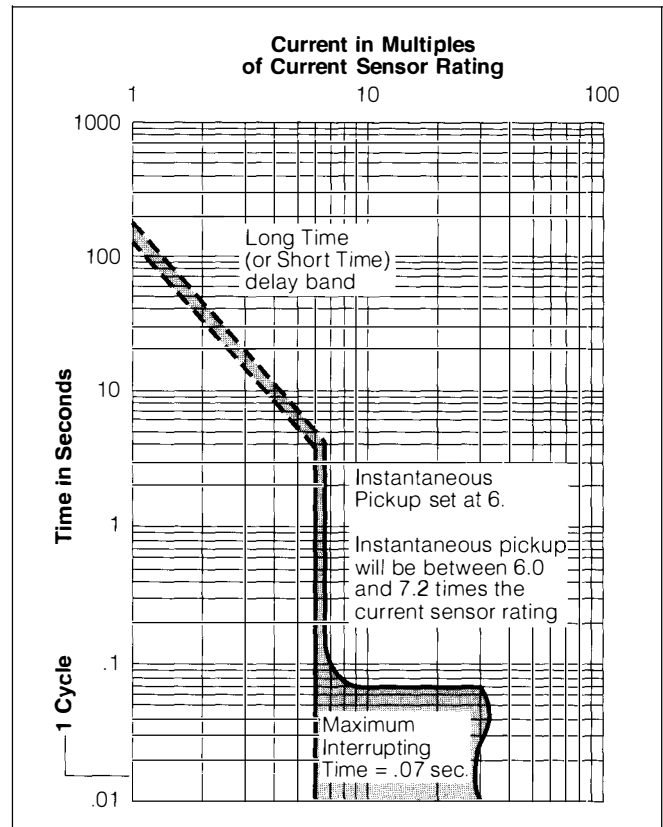

Example – Instantaneous Pickup
Refer to drawing 18-754-889-401 for accurate time current plot.

Installation and Adjustments Instructions

Ground Fault Protection

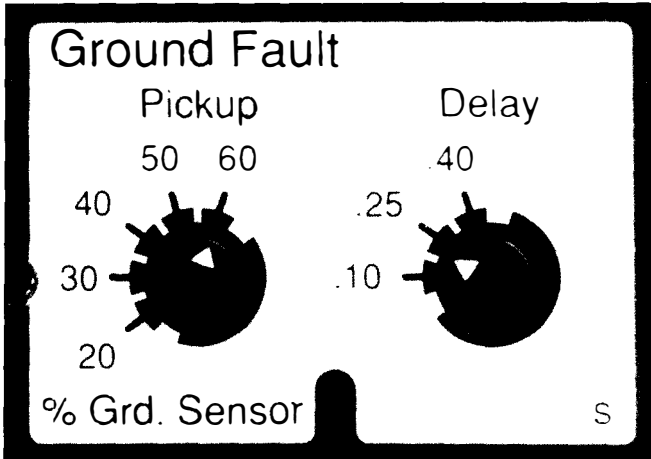

On trip units with both Short Time and Ground Fault Protection, the ground fault tripping is inhibited if the trip unit is executing the short time fault protection sequence.

Ground Fault Pickup

The ground fault pickup sets the level of ground current at which the circuit interruption sequence is initiated. Together with the ground fault delay, this setting allows selective tripping between main and feeder or other downstream circuit breakers. The ground fault pickup may be set to 20, 30, 40, 50 or, 60% of the ground sensor rating. The tolerance on the ground fault pickup is plus or minus 10%.

Note that the ground fault pickup adjustment references the "Ground Sensor Rating." This gives simple referencing regardless of the type of ground fault scheme used. Furthermore, it allows trip units to be interchanged between circuit breaker frames of all ratings and between different ground fault schemes. The ground sensor rating appears on the circuit breaker rating label above the trip unit for residual ground fault sensing schemes, or on the right side of the circuit breaker cubicle for direct source or zero sequence type schemes. See the ground fault sensing diagrams for additional information.

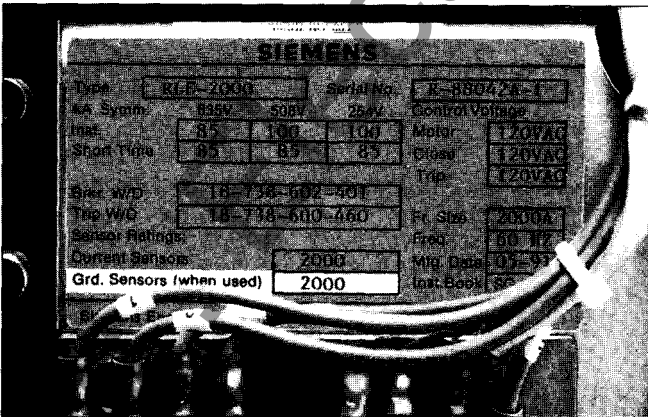

Residual Ground Fault Schemes

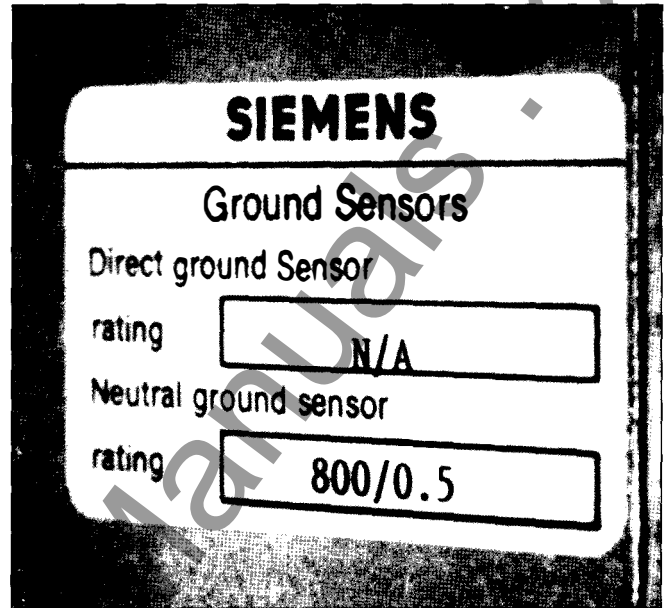

Direct Source or Zero Sequence Ground Fault Schemes

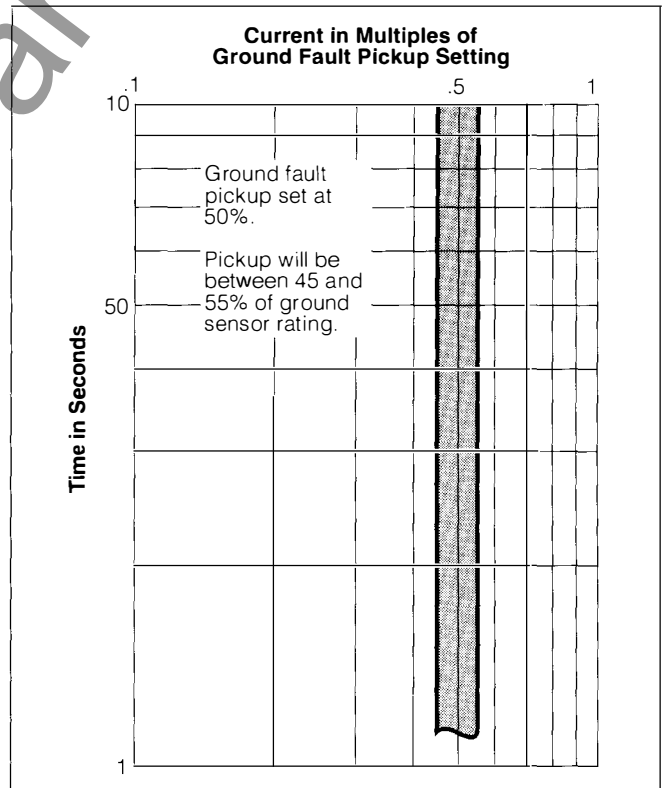

Example – Ground Fault Pickup
Refer to drawing 18-754-892-401 for accurate time current plot.

Installation and Adjustments Instructions

Ground Fault Delay

The ground fault delay sets the tripping delay of the trip unit in response to a ground current in excess of the ground fault pickup level. The ground fault delay band is an inverse I²t ramp function that reverts to a fixed delay at the value selected with the ground fault delay switch. The lower value of the I²t delay band is preset to a value of .5 seconds at a ground current corresponding to 1.5 times the ground fault pickup. The fixed delay may be set to .10, .25, or .40 seconds.

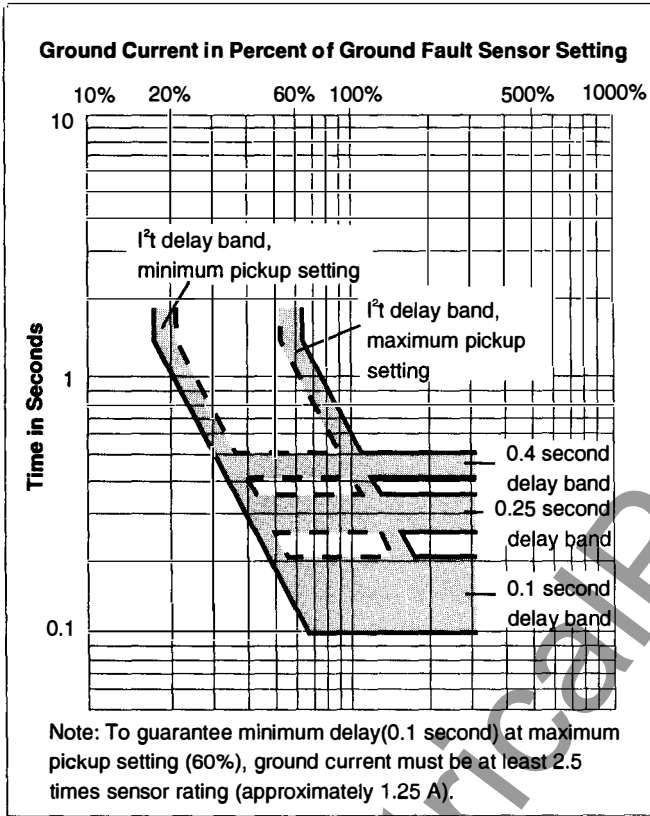

Example – Ground Fault Delay Bands
Refer to drawing 18-754-892-401 for accurate time current plot.

Ground Fault Memory Circuit

All Static Trip III trip units with ground fault protection come equipped with a ground fault memory circuit. This circuit effectively integrates ground fault currents with time. This provides an added protection by preventing the ground fault delay circuits from being reset when the ground fault currents are intermittent and/or erratic. The time constants for the current integration are preset within the trip unit as a function of the ground fault delay.

Constructing a Time-Current Curve

The following instructions are for constructing a Time-Current Curve for a trip unit with long time, short time, and instantaneous fault protection. The construction of a curve for ground fault protection or for trip units without short time or without instantaneous fault protection is very similar.

1. Select the long time setting and delay band to be used.
Example: .6 long time setting
10-second delay band

2. Select the short time pickup.
Example: 4 times the long time setting

3. Lightly trace a line from the long time pickup point to the reference point given in the table below for the selected Long Time Delay Band. Now darken the line between the long time pickup point and the intersection with the minimum short time pickup line; extending the trace, if necessary (this intersection defines the short time pickup point). This line is the lower limit of the long time delay band. (Note: without short time fault protection the line would extend to the instantaneous pickup point.)

Example: From (1x, 360 sec) to short time pickup point (The line would pass through the reference point (6x, 10 sec).)

Long Time Delay Band	Long Time Pickup Point	Reference Point
30 seconds	(1x, 1080 sec)	(6x, 30 sec)
17 seconds	(1x, 612 sec)	(6x, 17 sec)
10 seconds	(1x, 360 sec)	(6x, 10 sec)
6 seconds	(1x, 216 sec)	(6x, 6 sec)
3.5 seconds	(1x, 126 sec)	(6x, 3.5 sec)

4. Draw a vertical line from the top of the graph to the long time pickup point. This line defines the minimum long time pickup.

Example: From (1x, 10000 sec) to (1x, 360 sec)

5. Select the short time delay band to be used.

Example: .3-second delay band

6. Draw a vertical line from the short time pickup point on the long time delay line to the selected short time delay. This line defines the minimum short time pickup.

Example: From the short time pickup point to .3-second time line

7. Select the instantaneous pickup.

Example: 12 times current sensor rating

Since the instantaneous pickup is selected with respect to the current sensor rating, it must be divided by the long time pickup to determine its position on the graph

Example: $12 \div .6 = 20$

8. Draw a horizontal line along the short time delay line from the short time pickup line to the instantaneous pickup point. This line is the lower limit of the short time delay band.

Example: From 4 to 20 along the .3-second time line

9. Draw a vertical line from the instantaneous pickup point to the bottom of the graph. This line defines the minimum instantaneous pickup.

Example: From (20x, .3 sec) to (20x, .01 sec)

10. The maximum lines of the long time pickup, long time delay band, and short time pickup are offset from the minimum lines by 20%. The maximum line of the short time delay band is .08 seconds greater than the delay setting. Draw these lines.

Example:

- a. Maximum long time pickup is a vertical line from (1.2x, 10000 sec) to (1.2x, 360 sec).
- b. Maximum long time delay is from (1.2x, 360 sec) to maximum short time pickup (4 x 120% = 4.8). The line would pass through the new reference point (6 x 120% = 7.2x, 10 sec).
- c. Maximum short time pickup is a vertical line from the pickup point to the .38-second time line.

Installation and Adjustments Instructions

d. Maximum short time delay is a horizontal line along the .38-second time line from the maximum short time pickup to the maximum instantaneous pickup.

line extends from the maximum value of the short time delay band to .07 seconds, the maximum interrupting time.
 Example: $(12 + .6) \times 120\% = 24$

11. The maximum instantaneous pickup line is a line corresponding to a value that is 20% greater than the setting, The

12. The I²t short time ramp delay may be added to the Time Current Curve by using previously presented data, see Short Time Fault Protection.

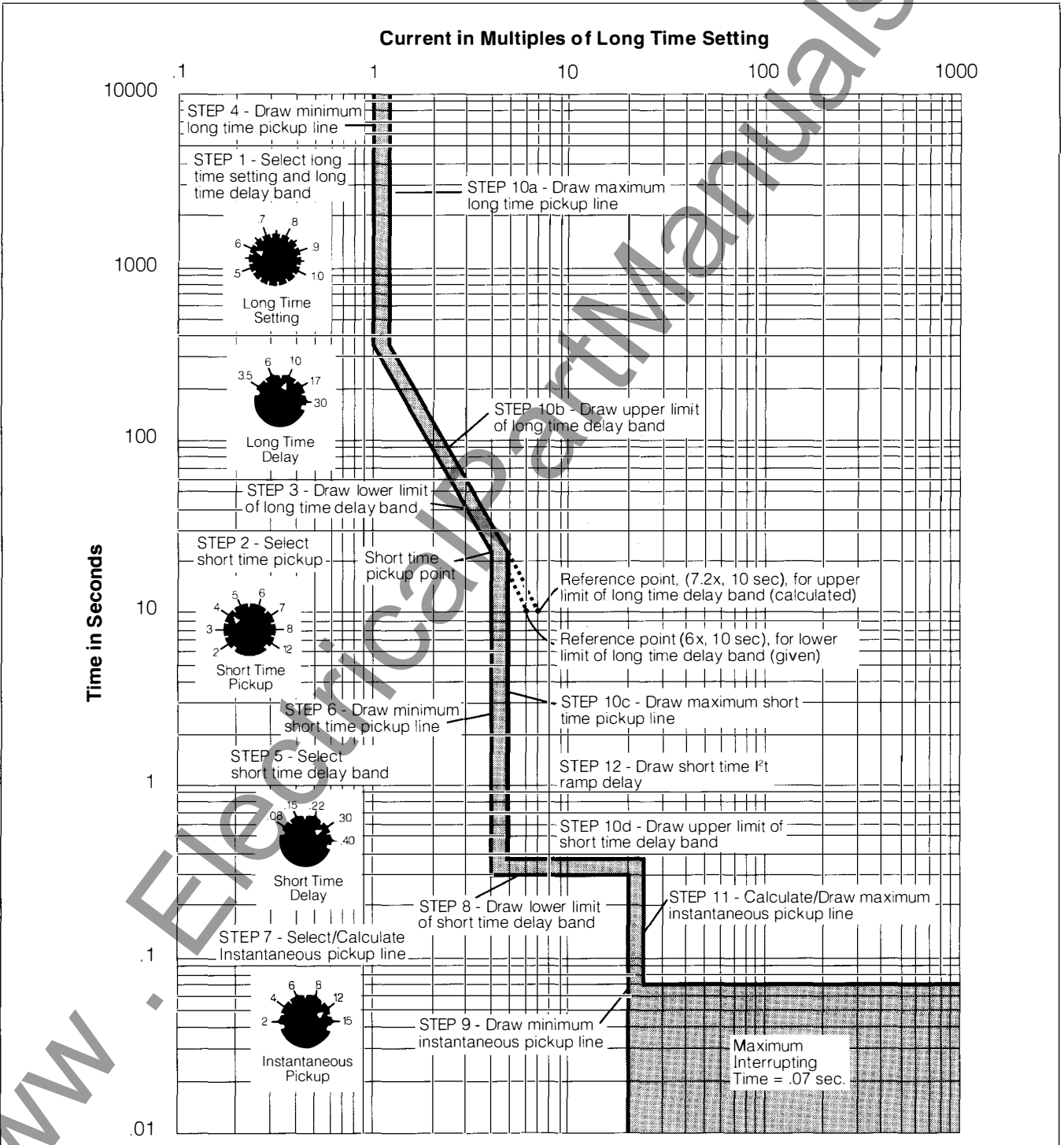

Example Time-Current Curve

Ground Fault Sensing Diagrams

Ground Fault Sensing Diagrams

The trip unit can be configured to accommodate the following ground fault sensing schemes.

- 3-Phase, 3-Wire Residual
- 3-Phase, 4-Wire Residual
- Direct Ground
- Zero Sequence

The following are brief descriptions of the ground fault sensing schemes as they relate to the Static Trip III trip units. Detailed technical and application information on the ground fault sensing schemes is contained in the Siemens Electrical Products Specification Guide (SG 306 1)

Residual (3-Phase, 3-Wire) - Under normal system conditions, (without the presence of a ground fault) the vector sum of the phase currents being monitored by the trip unit is zero. This is also true under the condition of an overcurrent phase-to-phase fault and phase unbalance condition. When a phase-to-ground fault occurs, the vector sum of the phase currents is directly proportional to the magnitude of the ground fault. The trip unit's microprocessor uses this vector sum data in the execution of the ground fault protection function. The trip unit utilizes the internal breaker current sensors. No external current sensors are required.

Circuit breaker current sensors are available with separate 2000A ground sensor windings to provide the 1200A maximum ground fault pickup setting required by NEC Article 230-95 for service entrance applications. Wiring diagrams for the two 3-Phase, 3-Wire ground fault sensing schemes are given in the Current Sensor Wiring Diagrams section. In either case, the current sensors are mounted on the circuit breaker. No external current sensors are required.

Residual (3-Phase, 4-Wire) - In the 3-Phase, 4-Wire Residual scheme a fourth current sensor is connected in the neutral conductor to "Sense" normal neutral currents. Under normal system conditions the vector sum of the currents in all phases equals the neutral current. This is also true under the condition of an overcurrent phase-to-phase fault and phase unbalance

condition. When a phase-to-ground fault occurs, the fault current returns via a path other than the neutral. Therefore, the vector sum of the phase currents no longer equals the neutral current. This current differential is detected by the trip unit and used in the execution of the ground fault protection function. Current sensors with separate 2000A NEC windings are usable for this sensing scheme, just as for 3-Phase, 3-Wire residual ground sensing (see Current Sensor Wiring Diagrams).

Direct Ground - In this scheme, the phase currents are not used in detecting and processing ground faults. The trip unit executes the ground fault protection function based on data from a ground current sensor. This sensor is located on the neutral connection to ground at the service entrance, and is connected to the appropriate input terminals on the trip unit (see Current Sensor Wiring Diagrams).

Zero Sequence - This scheme is very similar to the Residual Schemes. The traditional method is to use a core balance type current sensor which encircles all phase conductors and neutral on a four wire system. Under normal system conditions or a phase-to-phase fault condition, there is no output from the sensor to the trip unit because the vector sum of the currents through the sensor window is zero. If a ground fault occurs, the ground current is not seen by the sensor, which returns to the source by a path other than through the sensor window. The sensor detects this current imbalance and provides the data required by the trip unit to execute the ground fault protection function. The zero sequence sensor is connected to the appropriate input terminals of the trip unit (see Current Sensor Wiring Diagrams).

Alternatively, three or four current sensors or standard CT's can be connected together, as with the Residual Schemes described above. In this case, however, only the electrical sum of the sensor outputs is used as direct input to the trip unit's ground fault circuit terminals (the sensors are not used for phase current input). This is the electrical equivalent of the traditional magnetic core balance summation.

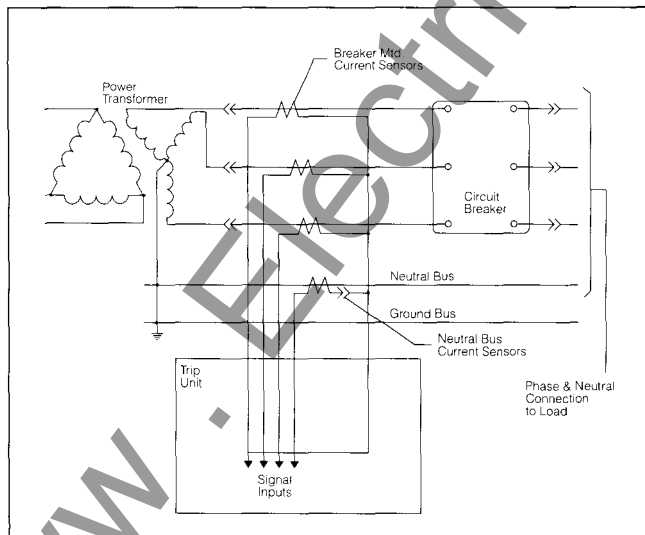

Residual Sensing, Circuit Breaker Wiring for Ground Protection (3-Phase, 4-Wire System Shown)

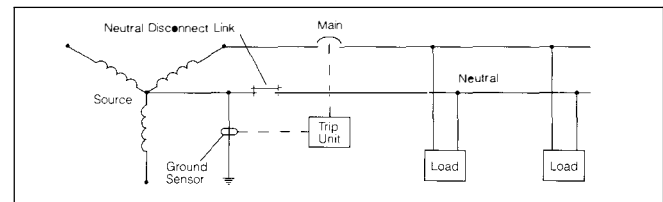

Direct Ground Current Sensing

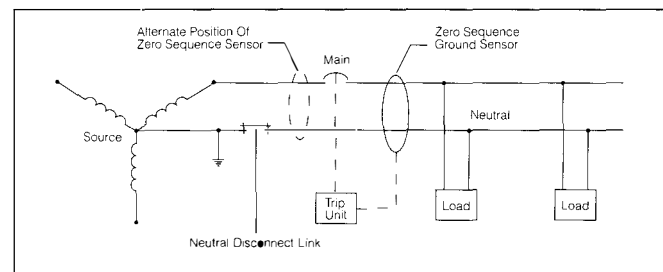

Zero Sequence Ground Fault Protection

Current Sensor Wiring Diagrams

Circuit Breaker Current Sensor Wiring Diagrams

The wiring diagrams shown here represent the standard circuit breaker wiring schemes to connect current sensors to the Static Trip III device. These schemes have been designed to meet a variety of ground fault and neutral current sensing methods while maintaining interchangeability of trip units. Note that trip units with the "N" suffix have terminal blocks with a ninth pin for separate neutral current measurement. While each wiring scheme is intended for a specific ground fault or neutral current measurement application, different model trip units can be substituted without affecting basic phase overcurrent protection. Refer to the equipment and circuit breaker wiring diagrams for each specific order for additional information.

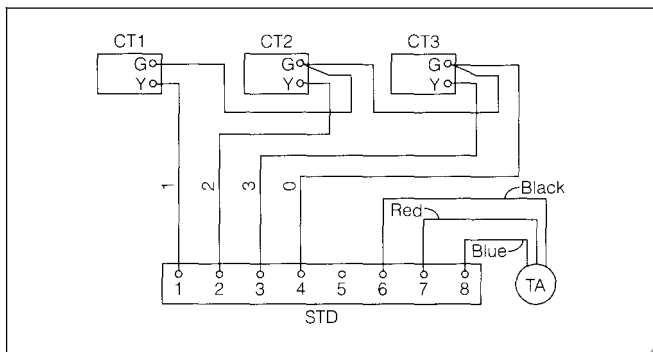

Figure 1 - 3W (or 3WR)

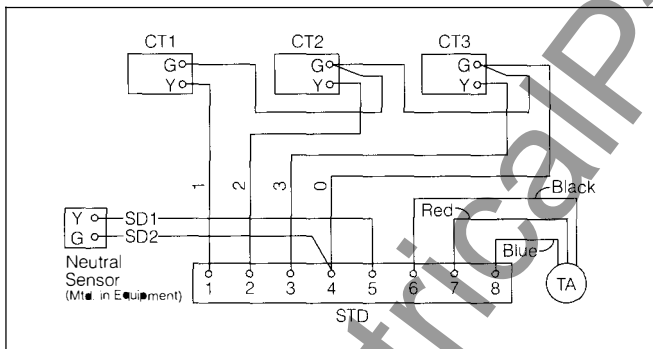

Figure 2 - 4WR

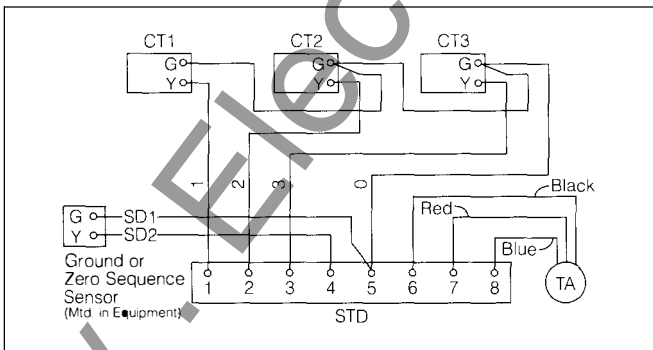

Figure 3 - 4WD

- Legend:**
 CT1 = Current Sensor Phase 1 (or A)
 TA = Tripping Actuator
 STD = Static Trip III Device
 SD1 = Secondary Disconnect Pin 1

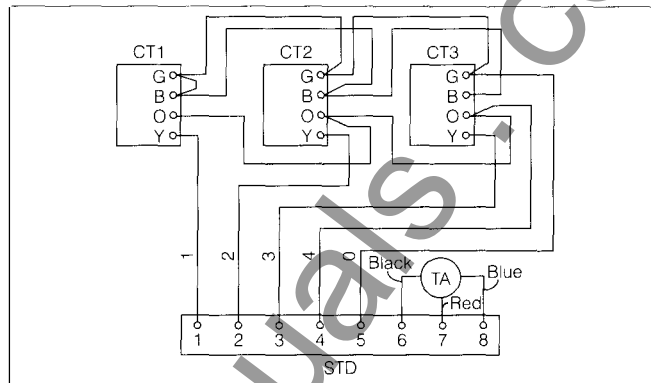

Figure 4 - 3WR-NEC

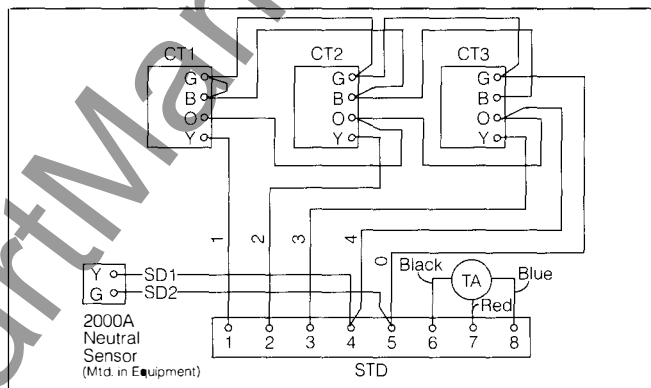

Figure 5 - 4WR-NEC

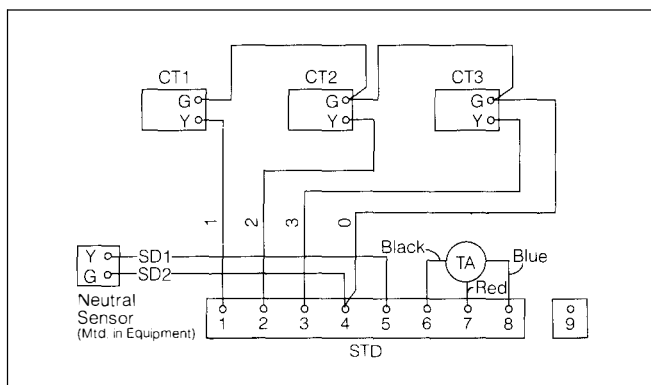

Figure 6 - 4WN (or 4WNR)

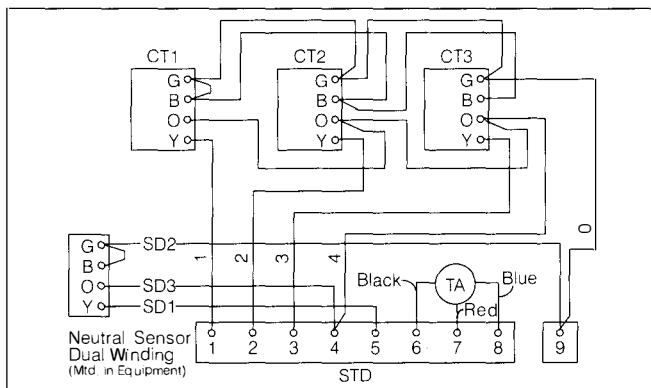

Figure 7 - 4WNR-NEC

Zone Interlocking

Zone Interlocking

Zone interlocking capability is provided as standard on trip units with short time or ground fault protection, but additional components and wiring are required to connect trip units together into a functioning zone-interlocked system.

Zone selective interlocking of series connected circuit breakers provides for a closer coordination of short time and ground fault protection in a power distribution network. When a zone interlock type fault current is detected, the trip units send a blocking signal notifying the upstream circuit breakers that the fault is being cleared at a lower level. If a circuit breaker experiencing the fault receives a blocking signal, it executes the fault protection function based on the programmed short time or ground fault time delay band. If it does not receive a blocking signal, it executes the fault protection function based on the minimum delay band. This coordinated procedure provides for a high level of fault protection to the bus structure between the zones.

If, for some reason, the fault current is not cleared by the tripping of the lowest level circuit breaker experiencing the fault, the higher level circuit breakers' trip units continue their pre-programmed tripping functions at their set time delays.

Static Trip III trip units may be connected together to form a zone interlock network. They may also be connected into a zone interlock network with Siemens' molded case and/or insulated case circuit breakers' trip units. The connection of Static Trip III trip units into a zone interlock network is with a Multiplexer/Translator or with Zone Interlock Expander(s) and Zone Interlock Couplers (see Accessories section). The 15-pin sub "D" connector on the front of the trip unit is used in connecting the trip unit into the network. The zone interlock "In/Out" switch on the front of the trip unit provides local configuration control. Set the zone interlock switch to the "Out" position when not used in a zone interlock network to avoid selective coordination problems.

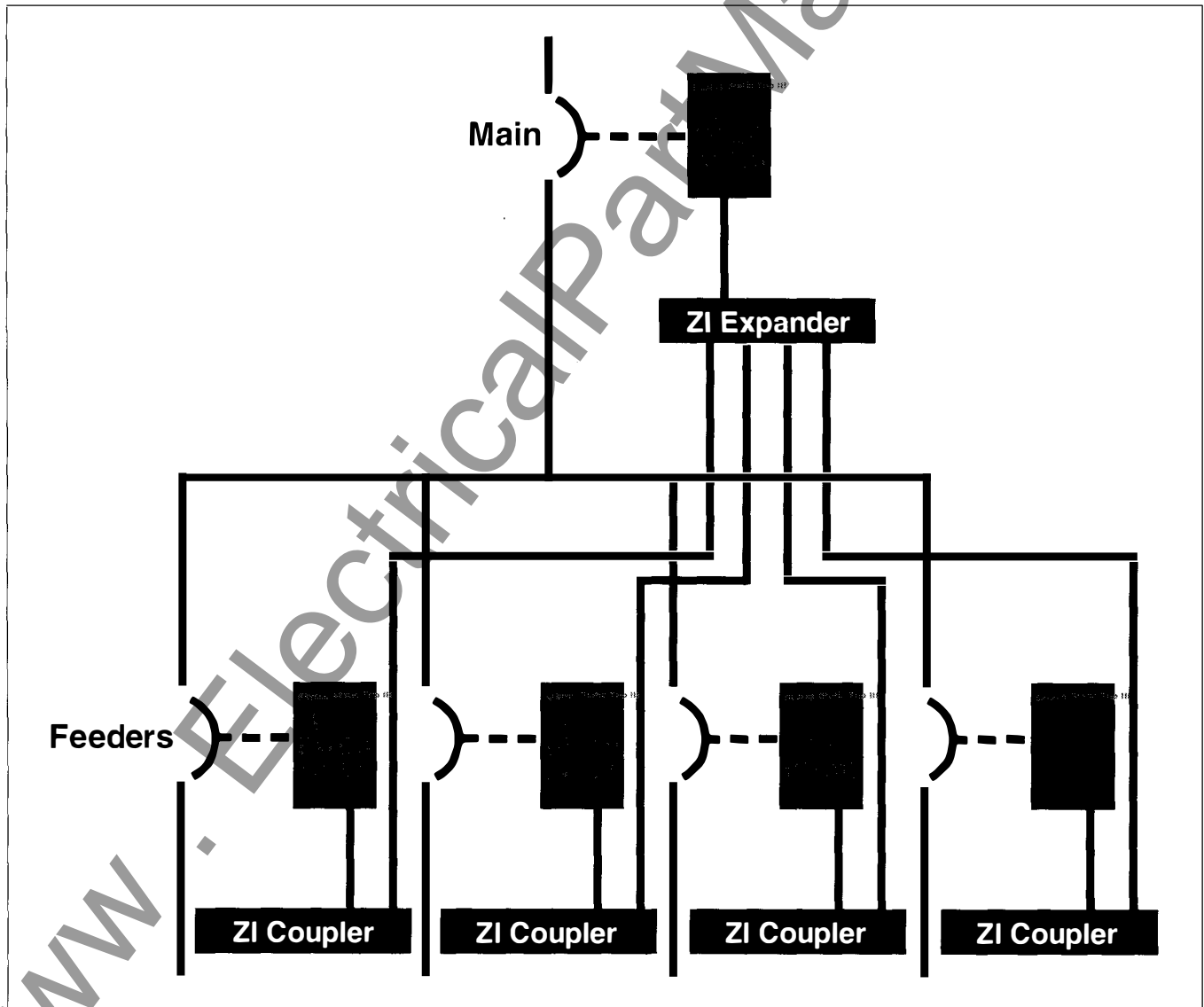

Example of Zone Interlocking Connection between Static Trip III devices

Metering and Extended Protective Relaying

Metering Functions

The metered and logged parameters of Static Trip IIIC/CP/CPX trip units may be monitored remotely over the communications bus or locally with the Breaker Display Unit (see Breaker Display Unit section). The specifications of the metered parameters are given in the following table. The real-time and min/max values represent averages of each measured parameter over approximately one second.

Measured Parameters Specifications

Parameter	Description	Parameter	Description
Phase Currents	Measured RMS Value of each Phase Current Range: 0 to 1000% of Phase Current Sensor Primary Rating Accuracy: $\pm 1\%$ of Phase Sensor from 10% to 125% of Phase Sensor BDU Display: Ia = XXXX Ib = XXXX Ic = XXXX	Frequency	Measured Line Frequency taken from Phase A Voltage Range: 45.0 to 70.0 Hz Accuracy: $\pm 0.25\%$ of reading provided Va is above 90V. BDU Display: Hz = XX.X
Average Phase Current	Arithmetic Average of Phase A, Phase B, and Phase C Currents BDU Display: I* = XXXX	Real Power	Signed Sum of the Measured Real Power of all 3 Phases in Kilowatts Range: $\pm 7,200$ (Normally Limited by Breaker Size) Accuracy: $\pm 2\%$ of Reading provided power factor is greater than 50% and current and voltage signals are within their specified accuracy ranges. BDU Display: kW = XXXX
Ground Current	Measured RMS Value of Ground Current Range: 0 to 125% of Ground Sensor Primary Rating Accuracy: $\pm 1\%$ of Ground Sensor from 10% to 125% of Ground Sensor BDU Display: Ig = XXXX	Reactive Power	Signed Sum of the Measured Power of all 3 Phases in Kilovars Range: $\pm 7,200$ (Normally Limited by Breaker Size) Accuracy: $\pm 2\%$ of Reading provided power factor is less than 90% and current and voltage signals are within their specified accuracy ranges. BDU Display: kQ = XXXX
Neutral Current	Measured RMS Value of Neutral Current Range: 0 to 1000% of Neutral Current Sensor Primary Rating Accuracy: $\pm 1\%$ of Neutral Sensor from 10% to 125% of Neutral Sensor BDU Display: In = XXXX	Apparent Power	Sum of the Apparent Power of all 3 Phases in Kilovolt Amperes Range: 0 to 7,200 (Normally Limited by Breaker Size) Accuracy: $\pm 2\%$ of Reading provided, current and voltage signals are within their specified accuracy ranges. BDU Display: kVA = XXXX
Phase Voltages	Measured RMS Value of each Phase Voltage (4 Wire Mode only) Range: 0 to 380 Volts Accuracy: $\pm 1\%$ of reading from 70 to 380 Volts BDU Display: Va = XXX Vb = XXX Vc = XXX	Power Factor	Ratio of Real Power to Apparent Power Range: -.99 to 1.00 Accuracy: .04 between .50 leading and .50 lagging provided current and voltage signals are within their specified accuracy ranges. BDU Display: PF = X.XX
Average Phase Voltage	Arithmetic Average of A, B and C Phase Voltages (4-Wire mode only) BDU Display: V* = XXX	Kilowatt Hours	Signed Accumulation of Real Energy in 1000's of Watt Hours Range: 0 to $\pm 9,999,999$ Kilowatt Hours Accuracy: $\pm 2\%$ of Reading BDU Display: kWh = XXXX (or MWh = XXXX)
Line Voltages	Measured RMS Value of each Line to Line Voltage (3-Wire and 4-Wire Modes) Range: 0 to 660 Volts Accuracy: $\pm 1\%$ of reading from 120 to 660 Volts BDU Display: Vab = XXX Vbc = XXX Vca = XXX	Kilowatt Hours Reverse	Accumulation of Real Energy in 1000's of Negative Watt Hours Range: 0 to $\pm 9,999,999$ Kilowatt Hours Accuracy: $\pm 2\%$ of Reading BDU Display: -kWh XXXX (or -MWh XXXX)
Average Line Voltage	Arithmetic Average of A-B, B-C, and C-A Line to Line Voltage BDU Display: V** = XXX	KiloVAR Hours	Signed Accumulation of Reactive Energy in 1000's of VAR Hours Range: 0 to $\pm 9,999,999$ KiloVAR Hours Accuracy: $\pm 2\%$ of Reading BDU Display: kWh = XXXX (or MWh = XXXX)

Metering and Extended Protective Relaying

Parameter	Description
kW Demand	Kilowatt Demand Using Fixed or Sliding Window Approach
	Range: $\pm 7,200$
	Accuracy: $\pm 2\%$ of Reading provided power factor is greater than 50% and current and voltage signals are within their specified accuracy ranges.
	BDU Display: kW D = XXXX

Power Flow Sign Conventions

Static Trip IIICP/CPX model trip devices are capable of measuring real (kW) and reactive (kVAR) power flows in both directions. The circuit breaker and trip unit symbols below show the example where the top terminals of the circuit breaker are connected to the normal power source, and the trip unit is configured with "V SOURCE" set to "TOP". The term "forward" power flow means that kilowatts (or kiloVARs) are being consumed by the "LOAD"; "reverse" flow means power is being supplied by the "LOAD". The sign conventions used for kW, kVAR and PF are shown in the four quadrants of the power diagram below.

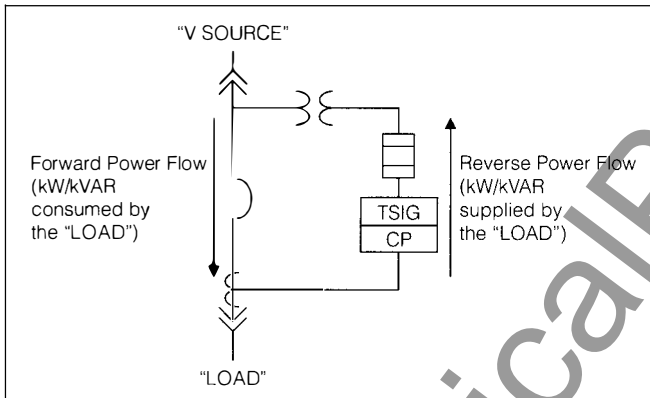

Circuit Breaker/Trip Unit symbols showing power flows

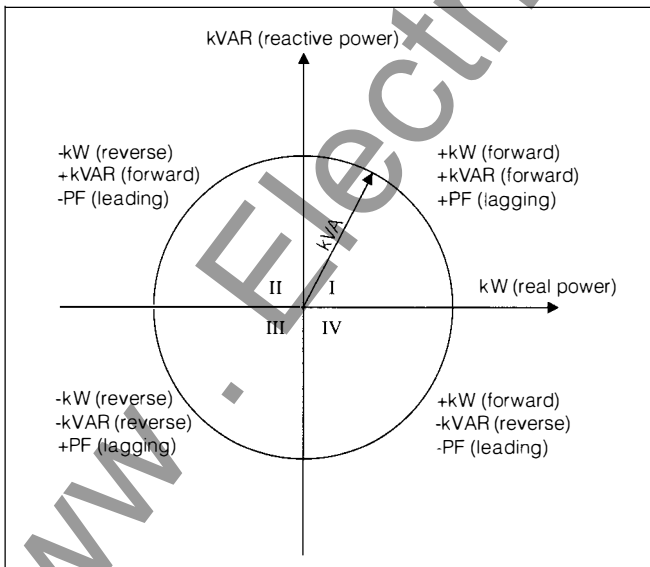

Power Diagram with Sign Conventions in each quadrant

Extended Protective Relay Functions

Extended protective relaying functions are provided with the trip unit when the "X" model type is ordered. There are 7 relaying functions, described below. Each function is capable of tripping the circuit breaker when the proper conditions are met. To activate a function, first set a pickup value and a delay value; then enable (turn on) the function. When the measured conditions relating to the appropriate function exceed the pickup value, a pickup flag will be set and the value of the measured conditions will be logged into the trip unit's event log. If the pickup stays on for the delay value time, the circuit breaker will be tripped. In addition, the measured conditions at the time of the trip, the relaying function which caused the trip, the breaker status, and the time of the trip will be entered into a trip log. The data in the event log and trip log can be viewed from a master device using the RS-485 bus. The trip log can also be read from the BDU accessory, but without time-stamp information.

Note: All relaying functions, except current unbalance, are prevented from operating unless the circuit breaker position is sensed as closed. This feature prohibits repetitive pickups and trip signals from being generated on an open breaker. Repetitive pickups would result in multiple writes to the event logs and trip logs; repetitive trip signals would result in multiple drive signals being sent to the actuator. For example: The undervoltage relay on an open feeder breaker is enabled with a pickup of 440 volts and a delay of 1 second. An upstream circuit breaker is opened. Without the above feature, the undervoltage relay on the feeder breaker would pickup, timeout, and attempt to trip. This process would repeat every 1 second until manually stopped. Therefore for proper operation of the relaying functions, the breaker position switch must be functioning properly.

Current Unbalance - Current Unbalance is a protective relay function that protects against an unbalance in the phase currents. Each phase current, (I_a , I_b and I_c) is compared to the arithmetic average of the three phase currents, I^* . Tripping occurs when any phase current exceeds the programmed unbalance pickup for a period of time equal to the delay time setting. The pickup must remain active for the entire delay time for a trip to occur. If the current unbalance condition subsides in less time than the delay time, the pickup will go inactive and the current unbalance protective relaying function will be reset. When tripping occurs, the actual condition that caused the trip is recorded in the trip unit's nonvolatile trip log.

Programmable settings:

Trip: Yes, No or Clr

Pickup: 5% to 50% in increments of 1%

Delay: 1 to 15 seconds in increments of 1 second

Average current is defined as $[I_a + I_b + I_c]/3 = I^*$.

Pickup occurs if the absolute value of $1 - (I_a/I^*)$ or (I_b/I^*) or $(I_c/I^*) \times 100\%$ is equal to or greater than the pickup setting. Current unbalance is disabled for any phase current less than 15% of sensor rating.

Data recorded in the event log:

Pickup Active: Time at which pickup went active and I_a , I_b , I_c at pickup.

Pickup Inactive: Time at which pickup went inactive.

Metering and Extended Protective Relaying

Voltage Unbalance - Voltage Unbalance is a protective relaying function that protects against an unbalance in the line-to-line voltages. Each line-to-line voltage, Vab, Vbc and Vca, is compared to the arithmetic average of the three line-to-line voltages, V^{**} . Tripping occurs when any line-to-line voltage exceeds the programmed unbalance pickup for a period of time equal to the delay time setting. The pickup must remain active for the entire delay time for a trip to occur. If the voltage unbalance condition subsides in less time than the delay time, the pickup will go inactive and the voltage unbalance protective relaying function will be reset. When tripping occurs, the actual condition that caused the trip is recorded in the trip unit's nonvolatile trip log.

Programmable settings:

- Trip: Yes, No or Clr
- Pickup: 5% to 50% in increments of 1%
- Delay: 1 to 15 seconds in increments of 1 second

Average line-to-line voltage is defined as $[Vab + Vbc + Vca] / 3 = V^{**}$.

Pickup occurs if the absolute value of $1 - (Vab/V^{**})$ or (Vbc/V^{**}) or $(Vca/V^{**}) \times 100\%$ is equal to or greater than the pickup setting. Voltage unbalance is disabled for any line voltage less than 15% of V SCALE.

Data recorded in the event log:

Pickup Active: Time at which pickup went active and Vab, Vbc and Vca at pickup.

Pickup Inactive: Time at which pickup went inactive.

Under Voltage - Under Voltage is a protective relaying function that protects against a line-to-line under voltage condition. Tripping occurs when any line-to-line voltage drops below the programmed under voltage pickup for a period of time equal to the delay time setting. The pickup must remain active for the entire delay time for a trip to occur. If the under voltage condition subsides in less time than the delay time, the pickup will go inactive and the under voltage protective relaying function will be reset. When tripping occurs, the condition that caused the trip is recorded in the trip unit's nonvolatile trip log.

Programmable settings:

- Trip: Yes, No or Clr
- Pickup: 60 to 660 volts in increments of 1 volt
- Delay: 1 to 15 seconds in increments of 1 second

Pickup occurs if Vab, Vbc or Vca is less than the pickup setting

Data recorded in the event log:

Pickup Active: Time at which pickup went active and Vab, Vbc and Vca at pickup.

Pickup Inactive: Time at which pickup went inactive.

Over Voltage - Over Voltage is a protective relaying function that protects against a line-to-line over voltage condition. Tripping occurs when any line-to-line voltage exceeds the programmed over voltage pickup for a period of time equal to the delay time setting. The pickup must remain active for the entire delay time for a trip to occur. If the over voltage condition subsides in less time than the delay time, the pickup will go inactive and the over voltage protective relaying function will be reset. When tripping occurs, the actual condition that caused the trip is recorded in the trip unit's nonvolatile trip log.

Programmable settings:

- Trip: Yes, No or Clr
- Pickup: 60 to 660 volts in increments of 1 volt
- Delay: 1 to 15 seconds in increments of 1 second

Pickup occurs if Vab, Vbc or Vca is greater than the pickup setting.

Data recorded in the event log:

Pickup Active: Time at which pickup went active and Vab, Vbc and Vca at pickup.

Pickup Inactive: Time at which pickup went inactive.

Under Frequency - Under Frequency is a protective relaying function that protects against an under frequency condition. Tripping occurs when the frequency drops below the programmed under frequency pickup for a period of time equal to the delay time setting. The pickup must remain active for the entire delay time for a trip to occur. If the under frequency condition subsides in less time than the delay time, the pickup will go inactive and the under frequency protective relaying function will be reset. When tripping occurs, the actual condition that caused the trip is recorded in the trip unit's nonvolatile trip log. Under Frequency is disabled if Va is less than 90V.

Programmable settings:

- Trip: Yes, No or Clr
- Pickup: 45.0 to 70.0 Hz in increments of .1 Hz
- Delay: 1 to 15 seconds in increments of 1 second

Pickup occurs if the frequency is less than the pickup setting.

Data recorded in the event log:

Pickup Active: Time at which pickup went active and frequency at pickup.

Pickup Inactive: Time at which pickup went inactive.

Over Frequency - Over Frequency is a protective relaying function that protects against an over frequency condition. Tripping occurs when the frequency exceeds the programmed over frequency pickup for a period of time equal to the delay time setting. The pickup must remain active for the entire delay time for a trip to occur. If the over frequency condition subsides in less time than the delay time, the pickup will go inactive and the over frequency protective relaying function will be reset. When tripping occurs, the actual condition that caused the trip is recorded in the trip unit's nonvolatile trip log. Over Frequency is disabled if Va is less than 90V.

Programmable settings:

- Trip: Yes, No or Clr
- Pickup: 45.0 to 70.0 Hz in increments of .1 Hz
- Delay: 1 to 15 seconds in increments of 1 second

Pickup occurs if the frequency is greater than the pickup setting.

Data recorded in the event log:

Pickup Active: Time at which pickup went active and frequency at pickup.

Pickup Inactive: Time at which pickup went inactive.

Metering and Extended Protective Relaying

Reverse Power - Reverse Power is a protective relaying function that protects against an excessive reverse power condition. Tripping occurs when the reverse power exceeds the programmed reverse power pickup for a period of time equal to the delay time setting. The pickup must remain active for the entire delay time for a trip to occur. If the reverse power condition subsides in less time than the delay time, the pickup will go inactive and the reverse power protective relaying function will be reset. When a tripping occurs, the actual condition that caused the trip is recorded in the trip unit's nonvolatile trip log.

Programmable settings:

- Trip: Yes, No or Clr
- Pickup: 10 to 7200 kilowatts (kW) in increments of 1 kW
- Delay: 1 to 15 seconds in increments of 1 second

For convenience, the pickup value is entered as a positive value. Pickup occurs if the measured power is negative and the absolute value of the measured power is greater than the pickup setting.

Data recorded in the event log:

- Pickup Active: Time at which pickup went active and measured power at pickup.
- Pickup Inactive: Time at which pickup went inactive.

Trip Log - The last 3 tripping events are recorded in the trip unit's nonvolatile trip log. Included in the recording are the time of the trip (year, month, day, hour, minute, second, and hundredths of seconds), the condition of the circuit breaker (open, closed or failure), all the basic and extended pickups which were active at the time of the trip, the condition of the trip unit's protection microprocessor (Pass/Fail), and the actual protective function (basic, extended, or shadow) which caused the trip. A "failure" condition is recorded if the circuit breaker position is not sensed to go open within a set time limit after a trip command is issued. In addition, the relevant measured parameters at the time of the trip are also stored in the trip log. The measured currents at time of trip are calculated over approximately one cycle at the time a trip command is actually initiated. The magnitude of the measured current will be limited by saturation of the current sensors above about fifteen times rated primary current, but should still provide an indication of which phases were involved even for a major short circuit. All of the trip log information may be read by a master device, such as a Power Monitor™ panel via the RS-485 bus. The most recent trip event data, without the time-stamp information may be read locally with the Breaker Display Unit (see Breaker Display Unit section). Note that time stamped information requires a master device to periodically synchronize all device clocks on the RS-485 network. While time-stamp information is always stored in the trip log, it should only be relied on when a master is used to continuously monitor the network.

Trip Log Stored Parameters

Cause of the Trip	Parameters Stored in Trip Log
Overload Short Circuit Ground Fault Current Unbalance	Ia, Ib, Ic, and if option present – In, Ig Ia, Ib, Ic, and if option present – In, Ig Ia, Ib, Ic, Ig, and if option present – In Ia, Ib, Ic, and if option present – In, Ig
Over Voltage Under Voltage Voltage Unbalance	Vab, Vbc, Vca, and V** Vab, Vbc, Vca, and V** Vab, Vbc, Vca, and V**
Over Frequency Under Frequency	Hz, Vab, Vbc, Vca, and V** Hz, Vab, Vbc, Vca, and V**
Reverse Power	kW, KQ, and kVA
Shadow	Ia, Ib, Ic, and if option present – In, Ig

Alarm Functions

There are up to 15 different alarm functions available with a trip unit, depending upon the model type. The basic communicating trip unit, Static Trip III C, provides 2 or 3 alarm functions depending on presence of the ground fault protective function. The "P" option provides 11 additional alarm functions and the "N" option provides 1 more. Each alarm function is user programmable for mode of operation, alarm threshold value, and delay time.

There are two user-selectable operating modes associated with each alarm function. The first sets the alarm function on or off. In the off mode, alarm threshold and time delay values can be set, but no action will be taken. This effectively disables the respective alarm function. In the on mode, the alarm function is enabled and alarm activity associated with the respective alarm function will be recorded in the trip unit's event log. Both alarm activation and deactivation are stored in the event log. An alarm becomes active when the programmed alarm threshold value has been exceeded for the specified delay time. When an alarm goes active, the time, alarm function and associated measured parameters are written into the trip unit's event log. An alarm becomes inactive when the measured parameter no longer meets the programmed alarm threshold value. When an alarm goes inactive, the time and associated alarm function are written into the trip unit's event log.

The second user-selectable operating mode sets relay output control yes or no. Selecting yes will close the relay output contacts when the associated alarm function becomes active. The alarm function that causes the relay output contacts to close will be identified as part of its event log message, and will also be recorded in the trip unit's alarm log along with the associated measured parameters. The alarm log is a subset of the event log specifically for the purpose of allowing the BDU accessory to display what alarm function caused the most recent relay output contact closure. The relay output contacts will open when the measured parameter no longer meets the programmed alarm threshold value. If multiple alarm functions have been set to control relay output, the contacts will open when all functions set for relay control no longer meet their programmed alarm thresholds. The alarm function which last allows the relay output contacts to open will also be identified as part of its event log message. Operation of the relay output contacts can also be done remotely using

Metering and Extended Protective Relaying

the RS-485 communications bus. This requires that the master network device (such as the Power Monitor™ display and monitoring unit) first put relay output control in manual mode before open or close commands can be issued. While in manual mode, alarm functions are blocked from automatically opening or closing relay contacts; although alarm activation and deactivation events will still be recorded in the trip unit's event log. Note that manual operation of the relay output contacts using commands issued over the RS-485 bus will be recorded as "relay comm open" or "relay comm close" messages in the event log.

Operation of alarm functions is not directly affected by the circuit breaker position. If an alarm function is set on and becomes active or inactive, associated messages will be recorded in the event log even with the circuit breaker open. Likewise, if relay output control has been set to on, relay contacts will open or close regardless of circuit breaker position. This operating characteristic must be kept in mind when using the relay output contacts for control logic, interlocking, annunciation or other applications and when setting alarm limits.

Relay output control cannot be set to yes unless the alarm mode is set on. This effectively provides three possible operating modes for each alarm function as summarized in the table below.

Operating Mode	Settings		Alarm Actions		
	Alarm	Relay	Stored in Event Log ^①	Control Relay Output ^②	Stored in Alarm Log ^③
1	off	no			
2	on	no	x		
3	on	yes	x	x	x

① The event log is read using the RS-485 communications port and contains time-stamped information about the most recent alarm activation and deactivation events. When the relay output control is set to yes, the event log also identifies which function causes the relay to close and the function which allows the relay to open.

● Note that setting the relay output for manual control using the RS-485 communications bus will block control due to alarm activation and deactivation

③ The alarm log is read using the BDU accessory and contains information about the alarm function which causes the most recent relay output contact closure.

Note: If a trip unit is moved to a circuit breaker with different size sensors, which require the phase sensor and possibly the ground sensor values to be reentered, check the alarm limits to insure that their settings are compatible with the different sensor values.

Over Range Alarms - For these types of alarms, if any of the relevant measured parameters exceed the programmed alarm threshold for the alarm delay time, the alarm function will go active (assuming the alarm is not set to Off). After going active, the alarm will go inactive only when all the relevant measured parameters are below the programmed threshold value for at least 1 second. When negative values are programmed for the alarm threshold, the measured value will be considered to exceed the threshold only if the measured value is negative and its absolute value exceeds the absolute value of the threshold setting. For example, a measured value of -800 exceeds a programmed value of -700.

Over Range Alarms

Alarm Function	Alarm Threshold Range	Alarm Delay (Sec.)	Min. Model Type Req.	Measured Parameter
Over Phase Current	1-40,000 Amps	1-255	C	Ia, Ib, Ic
Over Ground Current	1-4,000 Amps	1-255	C	Ig
Over Neutral Current	1-40,000 Amps	1-255	CN	In
Over Voltage	60-660 Volts	1-255	CP	Vab, Vbc, Vca
Over KW	10-7,200 KW	1-255	CP	kW
Over KVA	10-7,200 KVA	1-255	CP	kVA
Over Frequency	45.0-70.0 Hz	1-255	CP	Hz
Over Reverse KW	10-7,200 KW	1-255	CP	kW
Over KW Demand	10-7,200 KW	1-255	CP	kWD
Over KVAR	10-7,200 KVAR	1-255	CP	kQ

Under Range Alarms - For these types of alarms, if any of the relevant measured parameters are less than the programmed alarm threshold for the alarm delay time, the alarm function will go active (assuming the alarm is not set to Off). After going active, the alarm will go inactive only when all the relevant measured parameters are greater than the programmed threshold value for at least 1 second.

Under Range Alarms

Alarm Function	Alarm Pickup Range	Alarm Delay (Sec.)	Min. Model Type Req.	Measured Parameter
Under Voltage	60-660 Volts	1-255	CP	Vab, Vbc, Vca
Under Frequency	45.0-70.0 Hz	1-255	CP	Hz

Unbalance Alarms - Unbalance is defined as the comparison of a measured phase current or line-to-line voltage to the arithmetic average of all three measured phase currents or line-to-line voltages. The unbalance is expressed in percent. All three measured parameters, regardless of their magnitude, are used in determining the average. When calculating the unbalance, a measured parameter is used only if its magnitude is greater than 15% of the phase sensor rating for current or 15% of V SCALE for voltage. If the calculated unbalance exceeds the threshold value for the alarm delay time, the alarm function will go active (assuming the alarm is not set to Off). After going active, the alarm will go inactive only when the calculated unbalance drops below the programmed threshold value for at least 1 second.

Unbalance Alarms

Alarm Function	Alarm Pickup Range	Alarm Delay (Sec.)	Min. Model Type Req.	Measured Parameter
Current Unbalance	5%-50%	1-255	C	Ia, Ib, Ic
Voltage Unbalance	5%-50%	1-255	CP	Vab, Vbc, Vca

Power Factor Alarm - The Power Factor alarm is a unique type of alarm function. It is displayed as a signed value from -0.01 to +1 to +0.01. Unity power factor is +1.00. Power factors less than unity are displayed signed to indicate leading or lagging.

Metering and Extended Protective Relaying

Power Factor Scale

Unity
Leading -0.01, -0.02, -0.03...-0.98, -0.99 +1.00, +0.99, +0.98...+0.03, +0.02, +0.01 Lagging

Power Factor alarm characteristics:

- Alarm pickup-1 range: $-.01 - +.01$
- Alarm pickup-2 range: $-.01 - +.01$
- Delay time: 1–255 sec.
- Min. model type req.: CP
- Measured parameter: PF

The Power Factor alarm has 2 pickup values, each of which can be programmed to any point along the scale. The Power Factor alarm will go active when the measured power factor (PF) falls outside of the pickup points set along the scale for the programmed delay time. The following examples illustrate pickup settings and corresponding alarm regions along the power factor scale.

Example 1

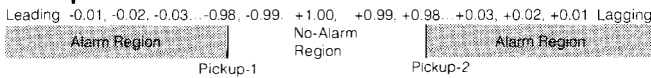

Example 2

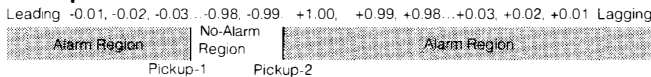

Example 3

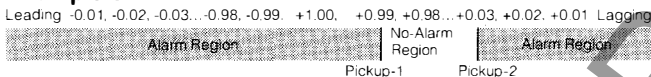

Note that the Power Factor alarm is disabled if I^* is below 15% or above 125% of sensor rating or V^{**} is below 15% of V SCALE.

Event Log - The event log uses active memory with the capacity to nominally record the 10 most recent alarm events. If any of the preceding alarms go active, the time the alarm went active, the name of the alarm function, and the values of the measured parameters associated with the alarm are written into the event log. If an alarm causes the alarm relay to close, an additional event is written signifying that the relay has closed and indicating which alarm caused the closure. When an active alarm goes inactive, the name of the alarm and the time that the alarm went inactive is written into the log. If the alarm going inactive results in a closed alarm relay being opened, an additional event is written indicating which alarm caused the relay to open and the time it was opened.

Upon request the event log information is sent to the master device, such as a Power Monitor™ panel, via the RS-485 bus. The event log is not accessible with the BDU Breaker Display Unit, (see Alarm Log below).

Alarm Log - A separate alarm log is maintained by the trip unit for use by the BDU display accessory. This log records the last action which caused the alarm relay to close. This includes the 15 alarm actions plus remote closing or opening of the alarm relay via a command from a master device using the RS-485 bus.

Recalibration and Reprogramming

Updating program code in the trip unit's metering board normally will not require recalibration of metering functions. However, in the unlikely event that the metering board microprocessor should have to be replaced, the trip unit must be returned to the factory for recalibration and reprogramming of the metering, protective relaying, and alarm functions to the factory default settings.

Calibration of the trip unit's metering functions can be done at the customer's site if the customer has the proper equipment. The equipment requirements are a 3-phase current and voltage source accurate to 1/4% or better with output ranges of 0.2500, 0.5000, and 1.000 amps and 300 volts. The phase angle between each current and voltage must be adjustable. Necessary delays are 0°, 90°, and -90°. Consult a Siemens Energy and Automation, Inc. sales office or field service office for more information.

Password Protection

Data can be read by anyone using the remote communications port with a master device such as the Power Monitor panel, or using the local communications port with a BDU device. Changing the configuration such as current sensor rating, alarm limits, extended protective relaying set-points, or trip unit address can be done only after entering a user-defined password. Passwords are stored in the master device (e.g. Power Monitor™ panel) and in the trip unit for the BDU display accessory.

Remote Monitoring and Programming

The communications port on the back of the trip unit provides an industry-standard RS-485 interface for remote monitor and control equipment. The remote equipment may be a Power Monitor™ panel, personal computer (PC), or LAD display unit in the Siemens ACCESS™ system. The Power Monitor™ unit is a microprocessor-controlled display and monitoring device that provides real-time data display, discrete input status display, event logging, and programming of field devices which provide circuit protection and protective relaying for industrial AC power systems. For detailed information see the Power Monitor™ Instruction and Operation Guide, SG-4018. The ACCESS™ electrical distribution communications system provides the capability to monitor and manage the entire power distribution networks of energy-intensive facilities. Information on the ACCESS™ system is contained in the ACCESS™ Bulletin, SG 3099.

Local Monitoring and Programming

Local monitoring and programming can be done with a portable PC or with a Breaker Display Unit (BDU). The communications port on the back of the trip unit provides access for the portable PC. The Isolated Multi-Drop™ converter by Siemens may be used to provide an RS-485 to RS-232 interface for the PC.

The BDU is a simple and convenient device for reading the metered data and trip unit log. The BDU can also be used to set the configuration parameters and set-points of the alarms and extended protective relaying functions.

Metering and Extended Protective Relaying

Fundamental Configuration Parameters

The parameters described in this paragraph must be set for proper operation of the trip unit. They affect fundamental communications and metering functions. Parameters that must be set for a given trip unit model are indicated with a (+) in the following table.

Fundamental Configuration Parameters

Parameter	Trip Unit Model	
	IIIC/CN	IIICP/CNP/CPX/CNPX
Address	+	+
Baud Rate	+	+
Phase Sensor Rating	+	+
Ground Sensor Rating	+	+
Phase Rotation		+
Volts Source		+
Volts Scale		+
Volts Mode		+
Demand Period Length		+
Number of Periods		+
Comm Trip	+	+
Comm Close	+	+
Comm Open	+	+

Address - The Address must be set for all communicating model types. Valid ranges are 1 through 224. The trip units are shipped from stock at address 222. It is recommended that only addresses 1 through 221 be used in an installation. Each trip unit connected on the same network must have a unique address. The address 222 is also suggested as the "parking" address of any trip unit taken out of service.

Baud Rate - All trip units connected on the same network must have the same baud rate. Valid selections for Baud Rate are 2,400, 4,800, and 9,600 baud. The trip units are shipped from the factory set for 4,800 baud.

Phase Sensor Rating - The Phase Sensor rating (or I SCALE) must be set equal to the primary amperage rating of the current sensor on the circuit breaker in which the trip unit is installed. Example: If the current sensor is rated at 800 Amps (800/0.5), then 800 would be the value used for the Phase Sensor Rating. This number affects the values displayed for the metered currents Ia, Ib, Ic and In (if ordered). On CP models it also affects the values displayed for kW, kVA, kVAR, kWh, kVARH, kWhR, and kWd. It also affects the operation of any current or power based alarm and relaying functions. The normal range of the Phase Sensor Rating is 80 to 4,000.

Ground Sensor Rating - The Ground Sensor rating (or G SCALE) must be set equal to the primary amperage rating of the ground sensor used by the circuit breaker for ground fault sensing. Example: If the ground sensor is rated at 800 Amps (800/0.5), then 800 would be the value used for the Ground Sensor Rating. This number affects the values displayed for the metered current Ig. It also affects the operation of the ground current based alarm function.

Phase Rotation - The Phase Rotation must be set to the phasing of the system in which the circuit breaker is installed. It may be set to ABC (normal phasing) or ACB (inverted

phasing). The setting affects values displayed for the voltages, kW, kVAR, kWh, kWhR, kVARH, and kWd. It also affects the operation of any voltage or power based relaying functions.

Volts Source - The Volts Source is settable to Top or Bottom. It should be set to Top if the power source is fed into the top of the circuit breaker; Bottom if the power source is fed into the bottom. This setting affects the displayed sign of the kW and kVAR readings. It also affects the accumulated values for kWh, kWhR, kVARH, and kWd and the operation of any associated alarm and relay functions.

Volts Scale - The Volts Scale is normally set to the nominal line-line voltage (208, 240, 380, 480, or 600) of the system. The value is used by the voltage unbalance alarm and relay functions. It does not affect the displayed voltage values.

Volts Mode - The Volts Mode is settable to 3-Wire or 4-Wire. Use 3-Wire when there is no neutral connection in the system; otherwise, use 4-Wire. In 3-Wire mode, phase to neutral voltages will not be measured or displayed.

kW Demand Period Length and Number of Periods - Demand Period Length is settable from 1 to 99 minutes. Number (of) Periods is settable from 1 to 15. This allows for fixed interval or sliding window methods of demand calculation. For the fixed interval, set the Length to the desired time and set the Number of Periods to 1. For the sliding window method, set the Length and the Number of Periods such that their product equals the desired demand interval.

Comm Trip - The Comm Trip is settable to either On or Off. All communications trip units are capable of tripping the circuit breaker via a series of commands from a master device using the RS-485 bus. Comm Trip must be set to On for the command sequence to be recognized and a trip to occur. Remote tripping of the circuit breaker is stored in the trip unit's event log. The Comm Trip setting does not affect the operation of any of the trip unit's protection functions, neither the basic nor the extended functions.

Comm Close - The Comm Close is settable to either On or Off. All communications trip units are capable of closing the circuit breaker via a series of commands from a master device using the RS-485 bus. Comm Close must be set to On for the command sequence to be recognized and a closure to occur. Remote closing of the circuit breaker is stored in the trip unit's event log. A special Anti-Pump "Y" Relay is used to integrate the Output 2 (close breaker) signal into electrically operated Type RL breaker wiring (see Instruction Manual SG3068 for details).

Comm Open - The Comm Open is settable to either On or Off. When used with the appropriate interposing relay, communications trip units are capable of opening an electrically operated circuit breaker via a series of commands from a master device using the RS-485 bus. Comm Open must be set to On for the command sequence to be recognized and an opening to occur. Remote opening of the circuit breaker is stored in the trip unit's event log.

Metering and Extended Protective Relaying

The Output 1 contact located on the back of the trip unit is used for the Comm Open function. The contact can be controlled by either the Comm Open command or by an alarm action, but not by both. When Comm Open is set to On, the alarm functions are prohibited from controlling the contact. Note that when the Comm Open is set to On and an open command is sent from a master device, the Output 1 contact will activate and then automatically deactivate when the 52b breaker position input indicates that the circuit breaker has actually opened. When the Comm Open is Off, control of the alarm relay output reverts to the alarm function, and will not automatically deactivate when the circuit breaker opens.

Default Values

The default values for the fundamental configuration parameters are given in the following table along with the source for programming proper values*.

* Trip units shipped separately from the factory for replacement, spare or retrofit use are all preprogrammed to the default values shown. Trip units shipped installed in circuit breakers for future compartments, spares or to OEM's will be preprogrammed to the values given on the breaker 90-series drawings for breaker-specific information such as phase current sensors. Trip units shipped as part of complete equipment should be preprogrammed to include application-specific information such as phase rotation and volt mode. This information is included in the communication diagram which is supplied as part of the standard customer drawing package with Siemens type R low voltage switchgear. Similar means of recording proper values should be used when the trip unit is installed in applications other than Siemens type R switchgear (consult equipment supplier or create a comparable documentation means as required).

Source for Configuration Parameters

Parameter	Default	Source of Configuration	
		One-line ①	Comm. Diag. ②
Address	222		x
Baud Rate	4,800		Default ③
Phase Sensor	150	x	
Grd Sensor	150	x	
Comm Close	Disabled	x	
Comm Open/Alrm	Disabled	x	
Comm Trip	Disabled	x	
Phase Rotation	ABC		x
Source	Top		x
Volt Scale	600		x
Volt Mode	3-Wire		x
kWD # of periods	15		x
kWD Length	1		x

Notes:

- ① Trip units factory installed in Type RL low voltage power circuit breakers are preprogrammed to breaker-specific information shown on the circuit breaker's 90-series drawing.
- ② Trip units installed in circuit breakers shipped with Type R low voltage switchgear will be preprogrammed to application-specific information shown on the communications diagram supplied with the equipment. Consult equipment manufacturer if trip unit is supplied in other equipment or create similar documentation means.
- ③ Use baud rate for specific system as required.

Static Trip IIIC Rear Connectors

There are two connectors on the rear of communicating trip units. A 10-position connector and a 4-position connector. The pin-outs and functions of these two connectors are given in the following tables.

Ten-Position Rear Connector

Connector Pins (1-10)	Function Use	Range
Earth Ground	Connects to Earth Ground	
+15 VDC typical	Power Supply Input	15 VDC +0/-1.5 at 200 mA C(NPX) only, 450 mA Max with BDU Plus I/O Source Load
15 VDC Return	Power Supply Return	
RS-485 Data +	Communications Network	
RS-485 Data -	Communications Network	
Not Used	Do Not Use	
Input 52b	Breaker Position Input	Must be "b" contact
Output 1	Alarm or Open Relay	+15 V at 100 mA Max Sink
Output 2	Breaker Close Output	+15 V at 100 mA Max Sink
I/O Source	Power Source for Output 1, Output 2, and Input 52b	+10 V at 200 mA, Short Circuit Protected in trip unit

Four-Position Rear Connector

Connector Pins (1-4)	Function use	Range
Phase A	PT Output Voltage Input	6.6 VRMS Max
Phase B	PT Output Voltage Input	6.6 VRMS Max
Phase C	PT Output Voltage Input	6.6 VRMS Max
Common	PT Output Common	

Programmable Settings Integrity Protection

The Static Trip IIIC(NPX) trip unit insures data integrity of its internal settings by performing a 16-bit Cyclic Redundancy Check (CRC) of its data. The CRC is made periodically and every time the trip unit's data is updated or changed by the user or when a "Clear Targets" command is issued. If the CRC should detect corrupted data, one of two error flags will be set. These "flags" are read as status bits in the RS-485 communications data packets, where they can be interpreted and displayed as error messages at a master device such as the Power Monitor™ display unit. One flag will be set only if the calibration factors used for metering data are corrupted. If this occurs, the trip unit will default to preset calibration values for metering but basic protective functions will not be affected; however, the trip unit should be recalibrated. The other flag will be set if the CRC detects corrupted data in either the configuration settings, extended protective relay functions settings, or alarm functions settings. If this should occur, the situation can usually be corrected by first checking the settings in each area mentioned and then correcting any errors. The flag can then be reset by doing a "Clear Targets" command from a master device (such as the Power Monitor™ display unit) on the RS-485 bus. Wait at least 60 seconds; if the flag returns have the trip unit serviced.

Testing

General

Static Trip III trip devices can be field tested either with primary current through the breaker or with secondary current applied directly to the trip device. The ease of testing with secondary current is one of the advantages of these devices. With comparatively inexpensive and readily available equipment, it is possible to demonstrate that the tripping system will open the breaker and verify that the device conforms to the published time-current curves. However, field testing cannot be expected to be as accurate as factory calibration. Therefore slight discrepancies between field tests and factory calibration can be regarded as normal. If large deviations or improper operation should occur, it is recommended that your Siemens Energy & Automation office be contacted for advice.

Secondary Current Testing

Portable test set PTS4 is available for secondary current testing and is designed to plug into a standard 120 volt outlet. With this test set, Static Trip III trip devices can be tested by themselves, or on a circuit breaker outside the cubicle, or inside the cubicle with the breaker in the TEST or DISCONNECTED position. A training videotape is available which shows proper operation of the PTS4 test set (see Ordering Information section).

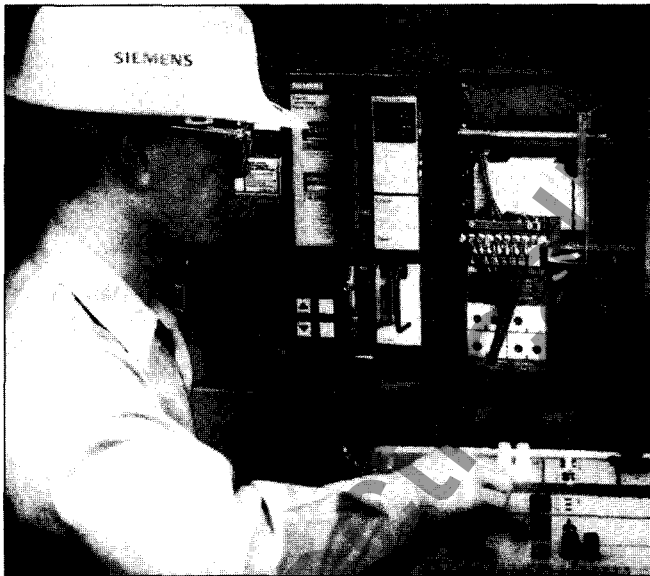

Portable Test Set PTS4

There is a terminal block on the circuit breaker just above the trip device. This terminal block accepts a plug from the test set when testing with the device on the breaker. Make all connections with power removed from the test set.

When testing with the Static Trip III device off the circuit breaker, connections must be made to the spade type terminals of the connecting strip. Making these connections involves the risk of shorting between clips which can damage the device. To avoid this, the PTS4 test set includes a terminal block for the connecting strip from the trip device similar to the one on the circuit breaker so that the spade terminals are properly isolated. The output of the test set is internally connected to the terminal block.

Static Trip III devices have two LEDs (Light Emitting Diodes) mounted on the front panel. One of these indicates Long Time Pickup and the other indicates Short Time or Ground Pickup. Unlike the earlier model of trip devices no connections are required to indicate when pickup occurs. These LEDs also operate during normal operation on the breaker, and are useful in indicating when the long time current setting may be set too low.

Test Connections

NOTE: When first trying to test Static Trip III devices with the neutral metering (CN or CNP) option, older style PTS4 test sets will need a minor mechanical modification. Refer to PTS4 manual SG-3138-01 for details.

Current is supplied to terminals 1 and 5 to test phase 1; 2 and 5 to test phase 2; 3 and 5 to test phase 3; and 4 and 5 to test the ground circuit on devices with ground fault tripping.

For secondary current testing a circuit breaker is not needed. If the device is mounted on a circuit breaker it is not necessary to close the breaker.

Long Time Pickup Test

Set the Long Time Current Setting on .5. Move the switch above the LED timer readout on the PTS4 to "Static Trip III Long Time" and select the phase to be tested. Raise the current slowly until the long time pickup LED is illuminated. This should occur between .25 and .30 amperes (or between the setting value and 120% of the setting value), as shown in Table 1. Decrease the current slightly and the LED should go out. When the LED is illuminated continuously the device will eventually time out. The Long Time circuits calculate the true RMS value. This produces a noticeable time delay (about 3 to 4 seconds) from the time the current reaches the pickup point to the time pickup is indicated by the LED.

Repeat the test for the other available settings and compare to the values in Table 1 below.

The current values for secondary testing of Static Trip III Long Time function are given in Table 1 below.

Table 1
Long Time Secondary Pickup Current

Current Setting		.50	.55	.60	.65	.70	.75	.80	.85	.90	.95	1.0
Secondary Amperes	Min	.25	.275	.30	.325	.35	.375	.40	.425	.45	.475	.50
	Max	.30	.330	.36	.390	.42	.450	.48	.510	.54	.570	.60

The illumination on the pickup LED indicates that the time delay has started. The timing circuit does not have the time lag evident in the pickup indication. When the "Thermal Memory" switch is "Out," the Long Time elements will be cleared each time the LED goes out; if the "Thermal Memory" switch is "In," the device will accumulate the overload times and will treat a series of short overloads as if it were one interval. While the overload is below the current setting the time register slowly resets, so that if the periods between overloads are long enough the device will not trip.

Short Time Pickup Test

Set Long Time Current Setting on .5 and Short Time Pickup on 2. Move the switch above the LED timer readout on the PTS-4 to "All Other Tests" and select the phase to be tested. Raise the current slowly until the Short Time/Ground Pickup LED begins to flash. This should be between .50 and .60 amperes (or the setting value and 120% of the setting value) as shown in Table 2. Repeat for other Short Time settings as desired making sure that the Instantaneous setting (if present) is not set below the Short Time Pickup. Note that the circuit breaker may trip (or PTS4 test set may sense trip signal and shut off power) very quickly after the pickup light comes on.

NOTE: Do not allow currents above one ampere to continue for more than a minute at a time to avoid overheating the trip device. A circuit breaker is provided in the PTS4 test set to prevent thermal damage from repeated high current tests.

Table 2
Short Time
Secondary Pickup Currents
(Long Time Current Setting on .5)

Short Time Pickup		2	3	4	5	6	7	8	12
Secondary Amperes	Min	.50	.75	1.00	1.25	1.50	1.75	2.00	3.00
	Max	.60	.90	1.20	1.50	1.80	2.10	2.40	3.60

Instantaneous Trip Test

Pickup for the Instantaneous element is demonstrated by tripping of the circuit breaker or operation of the targets and relay in the portable test set since immediate trip will be executed.

Instantaneous is calibrated in multiples of 0.5 ampere. Unlike the Short Time Pickup it is not effected by the current setting of the Long Time element.

Note: Do not allow currents above one ampere to flow for more than a minute, to avoid overheating the trip device. A circuit breaker is provided in the PTS4 test set to prevent thermal damage from repeated high current tests. At higher settings some of the other circuits may time out while the current is being raised to the instantaneous level. This can be minimized by setting the Long Time Current and Delay and Short Time Pickup on their maximum settings.

On devices with Targets the Short Circuit target should operate when the device operates on its Instantaneous or Short Time element.

Select the phase to be tested. Move the switch above the LED timer readout on the PTS4 to "All Other Tests". Set the Instantaneous on 2, increase the current slowly until the breaker trips and/or the PTS4 test set timer stops. This should occur between 1.0 and 1.2 amperes, as shown in Table 3. Test the other pickup settings as desired. See Table 3 for calibrated pickup values.

Table 3
Instantaneous
Secondary Pickup Currents^①

Instantaneous Pickup		2	4	6	8	12	15
Secondary Amperes	Min	1.0	2.0	3.0	4.0	6.0	7.5
	Max	1.2	2.4	3.6	4.8	7.2	9.0

^① Note on earlier model trip units with light grey faceplate, the tolerance for instantaneous pickup was $\pm 10\%$ rather than $+20\%/0\%$ for current production units.

Ground Pickup Test

Set Ground Fault Pickup on 60. Select Static Trip III ground test on the PTS4. Move the switch above the LED timer readout on the PTS4 to "All Other Tests". Raise the current slowly until the Short Time/Ground Pickup LED begins to flash. This should occur between .27 and .33 amperes, as shown in Table 4. Repeat for other Ground Fault settings as desired.

Table 4
Ground Fault
Secondary Pickup Currents

Ground Fault Pickup		20	30	40	50	60
Secondary Amperes	Min	.09	.135	.18	.225	.27
	Max	.11	.165	.22	.275	.33

Due to the low values of current, the trip device may not trip the circuit breaker when tested with secondary current into the ground circuit only. It may be necessary to supply some phase current in order to have sufficient power to release the tripping actuator. The PTS4 test set provides this function automatically.

Long Time Delay Test

Use the high range ammeter setting on the PTS4 test set.

1. Move the switch above the timer LED readout on the PTS4 to "Static Trip III Long Time" and select the phase to be tested.
2. Close the switch and set the current to the desired value.
3. Open the switch (and close the circuit breaker).
4. Without changing the setting of the current source, close the switch and measure the time until the breaker opens or PTS4 relay stops timing. Compare the results to the time current curves, (see curves in Installation and Adjustment Instruction, page 12)

Example: Set Long Time Current Setting on .5, Long Time Delay on 17. Input current at 1.5 amperes (6 times .25). Set Short Time Delay and Instantaneous on 12x. The timed interval should be between 17 and 25 seconds.

Testing

On models with targets the Overload target should indicate when tripping occurs.

Note: While timing out at values slightly above pick-up with the "Thermal Memory" switch "Out," normal variations in supply voltage may cause the device to drop out momentarily and cause the timing to be interrupted. It is recommended that the pickup LED be monitored throughout the test. Also, for the same reason, attempting to test Long Time timing at less than 20 percent above the current setting may not be successful.

Thermal Memory Test

The "Thermal Memory" function accumulates the Long Time signal and provides a cool down function for the Long Time delay. Switching the thermal memory "Out" disables the integrator and allows the long time delay elements to reset whenever the long time signal drops below pickup. When the "Thermal Memory" switch is "In" the long time delay elements are not reset when the signal drops below pickup, but are decreased slowly with time.

To check the operation of the circuit, set Long Time Current Setting on .5, Long Time Delay on 3.5 and move the "Thermal Memory" switch to "In." Make sure the switch above the LED timer readout on the PTS4 is set to "Static Trip III Long Time." Apply .55 amperes to one phase input and allow the device to time out. Record the time. Move the "Thermal Memory" switch to "Out," repeat the same test and record the time. It should be the same as the first test.

Now move the "Thermal Memory" switch back to "In." Repeat the test, but this time momentarily lower the current every 10 seconds to 0.2 ampere for approximately 3 seconds until the long time pickup LED goes out. Be very careful to not drop below 0.15 amperes. Again, measure and record tripping time. This should be somewhat longer than the first two tests. Move the "Thermal Memory" switch to the "Out" position and repeat this test. In this case the device should never time out and it should be possible to continue the cycle indefinitely.

Short Time Delay Test

To test, set Instantaneous to its maximum and move the small selector switch labeled Short Time I²t to "Out." Move the switch above the LED timer readout on the PTS4 to "All Other Tests" and select the phase to be tested. Set Long Time Current Setting on .5, Short Time Pickup on 2X, set the PTS4 test set current source for 2 to 3 amperes, and apply the test current. A timeout should occur within the limits of the Short Time Delay selected.

On models with Targets the Short Circuit target should operate. On models with Zone Interlocking the time delay will be approximately 0.1 second with the Zone Interlock switch "In."

NOTE: Normal variation in supply voltage to the PTS4 test set can cause significant changes to the test current output, especially at high current settings. Therefore, it is recommended that test currents be set at least 3 times the Short Time Pickup to ensure that the trip unit remains in pickup throughout the timing test.

Short Time I²t Test

To test, set Long Time Current Setting on .5, Short Time Pickup on 2X, Short Time Delay on .40, and move the Short Time I²t selector switch to "Out." Select "All other Tests" and "High"

current setting on the PTS4. Set test current to 1.5 amperes. Tripping times should be .40 to .50 seconds with I²t switched "Out", and about 1 second with I²t "In."

Ground Time Delay Test

The Ground time delay can be tested similar to the Short Time delay test. When the tripping output appears, the Ground Fault target appears.

Zone Interlock Test

On devices with the Zone Interlock option, both the Short Time and the Ground time delay bands are affected by the incoming ZI signal. With no incoming ZI signal both time delay bands will be on their minimum. When an incoming ZI signal is present both the Short Time and Ground delay elements operate on the band selected by the front panel controls.

On devices containing the ZI function, the ZI output circuit provides an output signal anytime either the Short Time or Ground pickup values are exceeded. Both the incoming and outgoing ZI circuits are isolated by an optical isolator inside the device, so some power must be provided to the trip devices, as in normal operation. Both sets of signals are brought out the 15 pin connector. Terminal numbering is from 1 through 15.

Pin 1 and 2 are the device negative power.

Pin 3 is the device +12 volt power

Pin 4 is the +5 volts from the target power supply

Pin 5 is the ZI positive signal input

Pin 6 is the ZI negative signal input

Pin 7 is the ZI negative signal output

Pin 8 is the ZI positive signal output

The signals from the 15 pin connector are connected together into a Zone Interlocking System through a Zone Interlock Coupler and/or Zone Interlock Expander mounted in the breaker cubicle.

To check the operation of the ZI input circuit, set the Short Time and Ground time delay bands above minimum band so that a difference in timing can be detected. Move the Short Time I²t switch to the "out" position and Zone Interlock switch to the "In" position. Run the time delay test as described previously. The measured times should correspond to the minimum time delay, regardless of setting. Now plug the ZI signal tester (18-732-790-563) into the 15-pin connector on the front of the trip unit. The LED on the ZI tester indicates when an outgoing ZI signal is present, and should light whenever Short Time or Ground Pickup occurs. The small toggle switch on the ZI tester can be used to activate an incoming ZI signal to the trip unit. With the incoming ZI blocking signal switched on, the measured delay should correspond to the time delay setting, not the minimum delay.

If the short time I²t switch is "In," the incoming ZI signal will not change the time delay unless the current used in the test is above the range where the I²t ramp circuits affect the delay.

Load Indicator Output Test

Early model Static Trip III trip devices have a nine pin connector on the front of the device to connect to the load indicator unit, (see page 49). If the load indicator is available it can be used to test the output signals. If there is a malfunction between the two assemblies, substitution of either unit is the best field test to isolate the defective assembly.

The output signal is a four bit, latched, parallel binary word representing the calculated RMS current in the highest phase. This is provided to the load indicator on pins 2 through 5 of the nine pin connector, with the following code.

Binary Word	Current, in Multiples of Long Time Pickup Value
0001	0.6x
0010	0.7x
0011	0.8x
0100	0.9x
0101	1.0x (this is long time pickup current)
0110	1.1x
0111	1.2x
1000	1.3x
1001	1.4x

The connector also contains +5 volts on pin 1 to power the load indicator.

The negative or common line is on pin 9.

Pin 8 is a signal called Not Reset . This signal is used to enable the load indicator and is +5 volts dc when current supplied to the trip device is above approximately 100 milliamperes. Below this input level none of the data is accepted. All pins can be checked with a voltmeter while current is adjusted as desired. Flickering of the LED output is normal.

The load indicator assembly decodes the number and drives a light emitting diode bar display to indicate the magnitude of current. The indicator also contains an alarm setting switchband circuitry that selects any one of the current levels indicated and closes a solid state alarm contact when that level is exceeded.

The solid state contact is rated 1 ampere, 125V nominal dc or ac.

Tripping Actuator Test

If the trip device fails to trip the breaker, the question arises as to whether the trouble is in the trip device or in the actuator. Substitution of a known trip device is an easy way to supply a quick answer.

If another trip device is not available, the actuator can be tested by applying voltage to its trip winding with the PTS4 test set. This winding connects to the terminal block with the positive terminal on number 7 and the negative terminal on number 6. The leads at the actuator are also color coded, red is positive, black is negative, and blue is the hold-in winding.

With the breaker closed apply DC voltage to the terminals for the trip winding, start at zero voltage and slowly increase until the actuator trips. The voltage should be between 3 and 6 volts. Should the actuator fail to trip check the coil resistance. It should be between 15 and 25 ohms. Double check the polarity of the test voltage and check for any mechanical interference in or around the actuator.

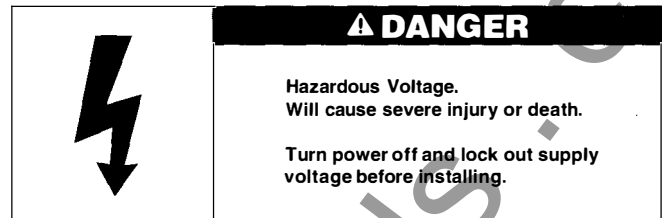

Do not disassemble the tripping actuator, this may partially demagnetize it, and remagnetizing requires special equipment.

Current Sensor Test

The tests described in the preceding verify performance of the trip device and tripping actuator.

The third link in the Static Trip III protection system is the breaker mounted current sensors. These are special purpose current transformers. When secondary current testing is done with the trip device on the breaker, the current sensors are subjected to approximately their normal excitation so that a transformer with shorted turns may show up in the form of pickup values above tolerance. However, further testing is required to tell if the problem is in the trip device or in the sensors. Moreover, an open circuit in the transformer winding or wiring would not show up at all. Therefore, it is desirable to test the current sensors as described in the following.

Connections

If the trip device is on the breaker, disconnect it by removing the connector strip from the lower row of terminal block connections. The current sensors can now be tested by making connections to the banana jacks on the top row of terminal block connections.

Continuity Checks

An ohmmeter is most suitable for checking the continuity of the sensor secondary windings and wiring. Connect the ohmmeter from terminal 1 to terminal 5 for Phase 1, from terminal 2 to terminal 5 for Phase 2, from terminal 3 to terminal 5 for Phase 3. The exact value of resistance is not important so long as there is continuity. The resistance should be approximately the same for all phases on a given breaker, but can vary widely for the various sensor ratings available.

When ground protection is provided, the ground sensor or neutral sensor, whichever is used, is mounted external to the circuit breaker and is wired to the trip device through the breaker secondary disconnects on the side of the breaker. To check this circuit the breaker must be in the TEST position. Then the ohmmeter check can be made between terminal 4 and terminal 5 of the trip device terminal block. The circuit breaker wiring diagram should be checked for any special connections that may have been made. When the neutral metering option is supplied, a ninth terminal is provided on the trip device terminal block. Check for neutral sensor continuity between terminal 9 and terminal 5 just as is done for ground fault.

Excitation Test

The purpose of an excitation test is to reveal shorted turns in the current sensor winding. Sixty (or 50) Hertz ac voltage is applied to the secondary winding and the exciting current is monitored. Short circuit turns will be revealed by excessive exciting current and possibly by overheating of the winding. A 120V variable transformer (Variac) and a low range ammeter is all that is required, although a 0-150 Volt ac voltmeter is desirable to monitor the applied voltage. The ammeter in the PTS4 test set can be used by passing current through the external current input.

In the absence of a voltmeter the dial reading on the variable transformer can be used as an approximate voltage indicator. See table 5.

Table 5
Current Sensor
Exciting Current Test

Sensor Rating	Applied Volts (V)	120 Volt Variac Setting	Maximum Exciting Current (A)
150	33.5	25	0.25
200	67	50	0.15
300	67	50	0.10
400	67	50	0.10
600	67	50	0.05
800	134	100	0.03
1200 & up	134	100	0.02

Again each phase must be tested in turn and the trip device must be disconnected. Connect the ac supply to terminals 1 and 5 for Phase 1, terminals 2 and 5 for Phase 2 and from terminals 3 and 5 for Phase 3. The output selector switch can be used to select each phase when the PTS4 test set is used as the AC ammeter. To test the ground sensor or neutral sensor it is necessary to have the breaker in the cubicle, in the TEST position. Again check the breaker wiring diagram, for any special connections that may have been made.

Table 5 gives the applied voltage and test limits of exciting current for all standard current sensor ratings.

The value of .02 ampere is about the lowest readable current using the ammeters in the PTS4 portable test sets, and the sensor that meets this limit will give satisfactory performance. Normal exciting currents for sensors rated 400 amperes and above may be well below this value. Therefore when checking high rating sensors it is essential to perform the continuity check. For the lower ratios the continuity check can be omitted since the indicated magnetizing current would verify continuity.

Sensor Polarity

For the ground fault detection elements to operate properly the sensors must be connected with the proper polarity. Siemens current sensors and ground/neutral sensors are checked for polarity at the factory and terminals are marked with a polarity dot. Therefore a simple check for proper connection according to the breaker wiring diagram is all that should normally be required to verify that the trip unit is receiving the correct ground fault signal.

If there is doubt that a given sensor is properly marked, its polarity can be checked by "flashing" the primary with a short duration pulse of known dc polarity and observing the polarity of the induced secondary voltage on make and break of the primary. A 6 volt dry cell can be used for the primary source and the polarity indicated by a dc voltmeter connected to the secondary winding. Refer to the equipment one line or breaker wiring diagram for the correct neutral or ground return sensor polarity.

Primary Current Testing

Testing with primary current applied to the circuit breaker requires a low voltage high current supply that can deliver currents up to 4 or 6 times the sensor rated current. There is commercially available equipment made for this purpose. This equipment generally includes the ammeters and timers needed to fully test the breaker.

Primary current testing can provide the ultimate in assurance that the entire protective system is functioning properly, since the entire system is tested at one time. However primary current testing may present additional problems. One major difficulty arises from the non-linear impedance of the trip device power supply circuit. This circuit is designed to provide power to operate at low levels of current then change impedance for higher levels of current to protect the trip device. When supplied from a low voltage source this changing impedance alters the waveshape of the current supplied to the trip device. This can result in insufficient power to properly operate the tripped device, or it may affect the indication of the source ammeter, depending on the ammeter design, leading to the erroneous assumption that the trip device calibration is incorrect.

Testing

One other major difficulty with primary current testing is related to the duty cycle limitation of the circuit breaker and current sensor. A properly operating tripping system will be self-protecting from thermal damage up to the circuit breaker short time and interruption rating, providing that the duty cycle applicable for each rating is not exceeded. The standard duty cycle for the short time rating as demonstrated per ANSI C37.50 is 0.5 Seconds On, 15 Seconds Off followed by another On period of 0.5 Second. The On intervals are too short to read the ammeter on the current source. For the instantaneous interruption rating each of the On intervals are reduced to approximately 50 Milliseconds. Because of this, calibration of the trip device high range settings cannot be accurately done with primary current.

The calibration can be verified safely at the lower settings and "operation only" verified at the higher set points.

IMPORTANT: If the duty cycle limits are exceeded during testing, the circuit breaker or current sensor as well as the trip device may be damaged. Between tests, the unit must remain OFF long enough to allow the current sensor to cool. In addition, if there is a fault in the system, the breaker may not operate within its rated time, and the system will not be self protecting.

Therefore to properly protect the tripping system from potential damage and still assure proper operation, the following procedure is recommended.

If the breaker has a ground fault sensing trip device connect a jumper between terminals 4 and 5 of the trip device.

1. Apply to one pole of the circuit breaker an input current of one half the current sensor rating and measure the trip device power supply voltage. This voltage can be measured with the negative lead of the voltmeter on Pin 1 or 2 of the 15 pin connector. The positive lead is terminal block number 7, the red lead of the actuator. If this voltage exceeds 11 Volts with half rated current supplied, it can be assured that the wave shape distortion can be disregarded except for its possible effect on the ammeter indication. Test all three poles of the breaker in a similar manner, this establishes that the device power supply circuits are working.
2. Set the long time current setting to the .5 position. Slowly increase the current from zero while watching the long time pickup LED. Pickup should occur at one-half the current sensor rating with a tolerance of minus zero to plus 20 percent, not including any ammeter error. Pickup is the lowest current at which the LED remains illuminated. Repeat for all three poles of the circuit breaker. This proves the input circuits are all working. When the pickup indication is present, the long time circuit timing element is released and the device will time out on LONG TIME.

Repeat calibration check on the other long time current settings as desired.

3. Set long time current setting on .5, long time delay on 3.5, short time pickup and instantaneous on 12. Set the input current equal to the current sensor rating. Remove and reapply the power, allow the device to time out and trip the breaker. The time delay should meet the published curves for the device being tested. Repeat for all long time bands. Note that the Static Trip III long time circuits respond to the RMS value of the input current, and depending on the type of ammeter being used the times may all appear to be longer than expected. If the test set has an RMS responding ammeter the time values should check properly.
4. Set instantaneous at 2, short time pickup at 12, long time delay on its maximum of 30. The breaker should trip instantaneous at twice the current sensor rated current with a tolerance of minus zero to plus 20 percent. Repeat for all three poles of the breaker.
5. Set short time pickup at 2, instantaneous at 12, long time delay on its maximum, and short time delay on minimum of .08. Set long time current setting .5. Slowly increase the current. The breaker should trip at the current sensor rated current with a tolerance of minus zero to plus 20 percent. The time delay circuit can allow the current to increase after tripping has been initiated, so the rate at which the current is increased must be limited to prevent "overshoot."
6. With the same settings as in step 5, adjust the supply current to 3 times the current sensor rating. Apply the current and observe the tripping time. Test all five short time delay bands. Note if the device contains Zone Interlocking, a ZI input signal must be supplied or the Zone Interlock switch moved to the "out" position in order to test other than the minimum time delay band.
7. Increase both instantaneous and short time pickup to 12, set the long time delay on 3.5, long time current setting on .5. Adjust the supply to twice current sensor rating. Apply this current and observe tripping time. Test at the same current for all long time delay bands. Verify that they meet the published values. Other values of current can be tested if overheating is prevented.
8. The operation of the Short Time I^2t ramp, and time delay bands can also be checked as desired.
9. If the device has ground fault tripping, remove the jumper from terminals 4 and 5. Set Ground Fault pickup on 60, increase the supply current from zero, verify that the ground circuit trips the breaker at 60% with a tolerance of plus or minus 10% of the Ground Sensor rating. Lower settings can be tested. Depending on the amount of waveshape distortion there may not be enough power to trip the breaker at the lowest available ground fault pickup value with no other phase currents.
10. To demonstrate operation at normal control settings, reset all controls to the desired values, set current to a high enough value to definitely cause tripping, apply current, and verify that tripping does occur as expected.

Testing

High Potential and Megger Testing

Static Trip III trip units are designed as part of an integrated tripping system and are not intended for direct connection to high voltage sources.

IMPORTANT: Injection of high potential to any of the trip unit connections (including current sensor inputs, tripping actuator outputs, PT module voltage inputs, control power input, RS-485 communications output or sub D connections on the front of the unit) may cause damage to the trip device or other portion of the tripping system including associated accessories. Therefore to properly perform high potential or megger testing on electrical equipment which contains circuit breakers with Static Trip III tripping systems, the following precautions should be observed:

1. The tripping system's current sensors provide adequate high voltage isolation from the primary circuits to allow normal high potential or megger testing between phases or from phase to ground without damage to the tripping system. Do not apply high voltage to any of the tripping systems secondary connections such as the current sensor output terminals or the trip unit connection terminal block.
2. For circuit breakers equipped with communicating model trip devices, do not apply high voltage to the communications secondary disconnect or to the RS-485 communications bus and 15V dc power supply wiring in the equipment or on the circuit breaker itself.
3. Circuit breakers equipped with power metering model trip devices use specially-designed PT modules to provide isolated voltage inputs to the trip device. These PT
4. modules are designed to withstand brief high potential testing at up to 2200V ac without damage to the trip unit or the PT module itself. While inadvertent high potential or megger testing should not cause damage, it will give erroneous readings. Therefore the PT module should be taken out of the circuit being tested, just as is normally done for traditional instrumentation. For cases where the PT module's input connections are made to the circuit breaker primary conductors, simply rack the breaker to the disconnected position to perform high potential or megger testing on the electrical equipment bus or cable runs. Otherwise, remove the PT module primary fuses to test the equipment or the breaker itself. Refer to circuit breaker or equipment wiring diagrams to determine how the PT module is used in your application.
5. Communicating model trip devices include low-level outputs which may be wired into alarm or remote open/close control circuits. When used, these outputs are wired into their respective control circuits through interposing relays which should be indicated on the equipment and/or circuit breaker wiring diagrams. The control circuit side of the interposing relays can be tested as is normally done for secondary wiring. Do not use high potential testing on the trip unit side of the interposing relay circuits.
5. Trip units with Short Time or Ground Fault protective functions may be wired together into a zone interlocking system. Zone interlocking couplers, expanders or multiplexer/translator devices are used to make these connections between devices. Do not use high potential testing on these zone interlocking connections.

Breaker Display Unit





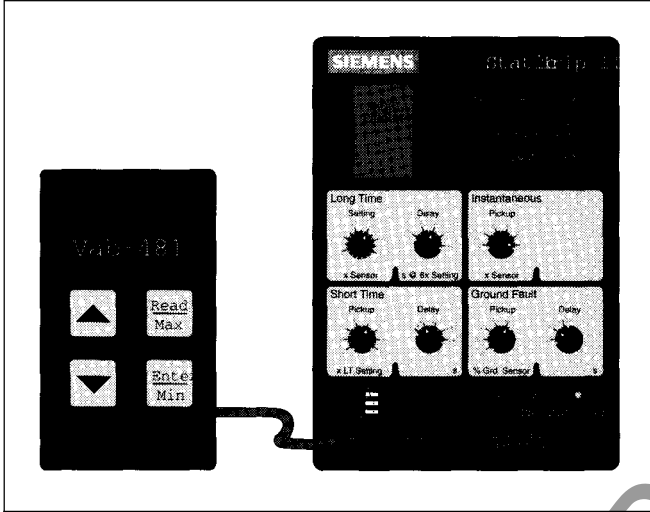

Breaker Display Unit

The Breaker Display Unit (BDU) is used to locally monitor and program Static Trip III trip units with metering and/or extended protective relaying capabilities. The BDU may be mounted on the front cover of Type RL circuit breakers or other surface near the trip unit. The BDU interfaces with the trip unit through the local communications port on the front of the trip unit. Power for the BDU is supplied by the trip unit, eliminating the need for an additional power source.



BDU Mounted on Type RL circuit breaker

Operator control of the BDU's display and trip unit programming is with the four-key key-pad. Each key has two primary functions, depending upon the parameter or data being displayed. The primary functions of the keys are briefly identified as follows:

-  • scroll to previous window in the sequence
-  • scroll to next window in the sequence
-  • read additional data
-  • display maximum value
-  • display minimum value
-  • enter displayed data (e.g. protection threshold)
-  • display maximum value

Selecting Operating Mode – There are two operating modes of the BDU. The data mode is used to read the parameters of the metered functions and to read the alarm, trip, and Min/Max logs. The program mode is used when setting the configuration parameters, alarm set-points, thresholds, and time delays.

Pressing Read and Enter at the same time toggles the BDU between the data and program modes. The modes will always start at the beginning of their respective routines, regardless of where the window was in the exited mode. The words "DATA" or "PROGRAM" will appear on the display, indicating the operating modes.

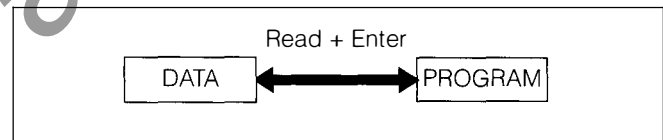

Toggle by pressing the Read and Enter keys at the same time.

Data Mode – The data mode is the default mode of the BDU. When power is first applied, the BDU will be in the data mode. If the BDU is in the program mode and a key is not pressed within five minutes, the BDU will automatically toggle to the data mode.

Reading Metering Data – The BDU may be allowed to automatically scroll through the real-time metered values or may be manually scrolled with the Up and Down keys. If no key has been pressed within 4 seconds after the data mode has been selected, the BDU will automatically start scrolling through the illustrated sequence. The automatic scroll mode will start immediately after initial power up or after executing the self test mode. The BDU does not automatically scroll through the alarm and trip logs. After the BDU has scrolled through and displayed all of the metered values, it automatically returns to the beginning and scrolls through the values again. The readout time of each displayed value is 4 seconds. The Up and Down keys may be used to more quickly scroll to a desired readout. The display will remain on the selected measured parameter until manually scrolled to another parameter or until the automatic scroll mode is executed again. When a reverse value is displayed, the display will alternately flash REVS and the metered value. Similarly, LEAD (or LAG) will flash when viewing power factor.

Breaker Display Unit

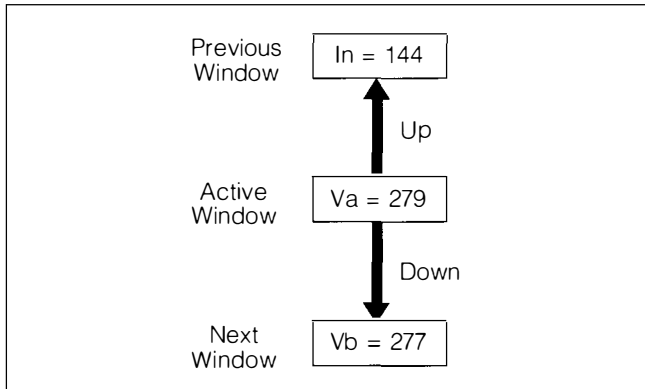

Scroll with the Up and Down keys

Data Mode Scrolling Sequence

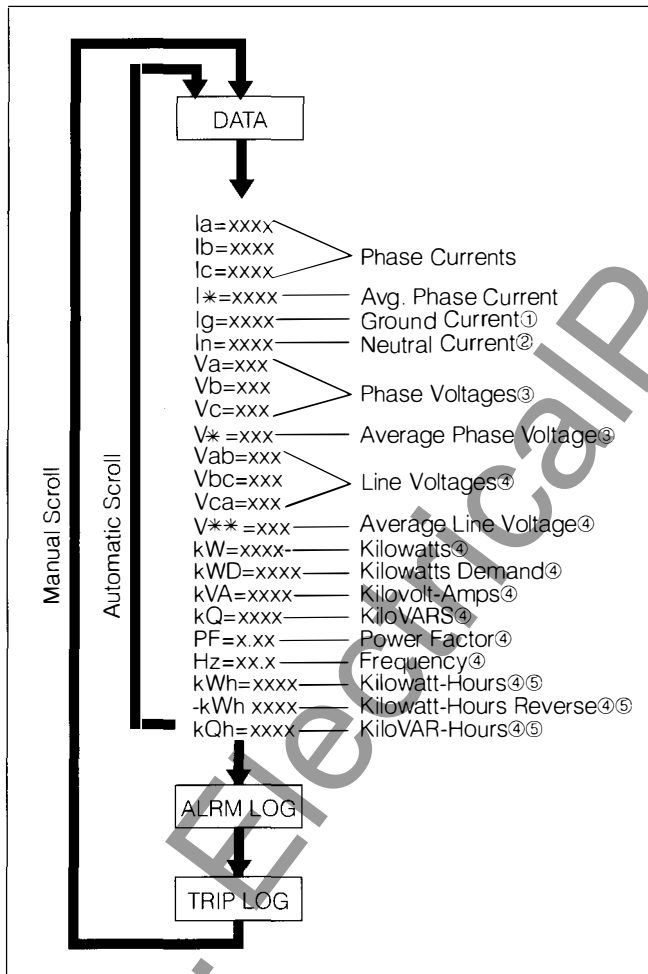

- ① Only displayed for trip units with ground fault protection.
- ② Only displayed for trip units with neutral current metering option
- ③ Only displayed for trip units with power metering option in "4-Wire" mode.
- ④ Only displayed for trip units with power metering option.
- ⑤ The reset for the kWh and kQh is in the program mode. Note that the BDU will automatically shift to MWh/MQh when the values of kWh/kQh exceed 9999.

Reading Maximum and Minimum Values – The maximum and minimum values of a displayed real-time parameter are read by pressing the Max and Min keys. The BDU will automatically return to displaying the corresponding real-time value if no other keys are pressed for 4 seconds. Pressing Up or Down while the BDU is displaying a maximum or minimum value scrolls to the real-time value of the next parameter in the sequence. The reset for the maximum and minimum values is in the program mode.

When the maximum power factor is displayed, the display will indicate leading or lagging.

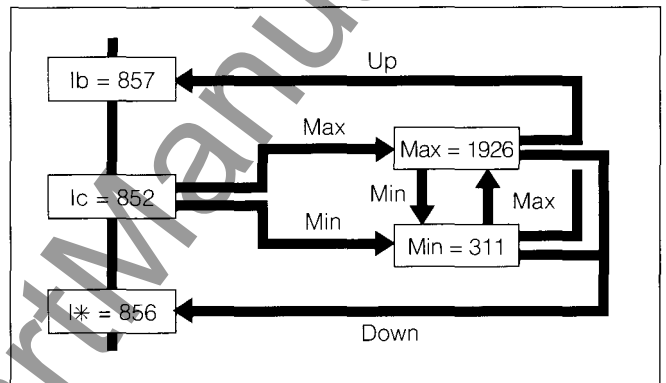

Reading the Maximum and Minimum values

Reading the Alarm (ALRM) Log – From the "ALRM LOG" window, the most recent alarm log event can be read by pressing Read to display the cause of the alarm, followed by Read (or Down) to display the associated measured parameters. The display will return to the "ALRM LOG" window when the Read (or Down) key is pressed after the last parameter is displayed. Pressing Down or Up from the "ALRM LOG" window scrolls the display to the next window in the sequence. The cause and associated measured parameters displayed are given in the following table. The message "No Log" will be displayed if there is no alarm information available from the trip unit.

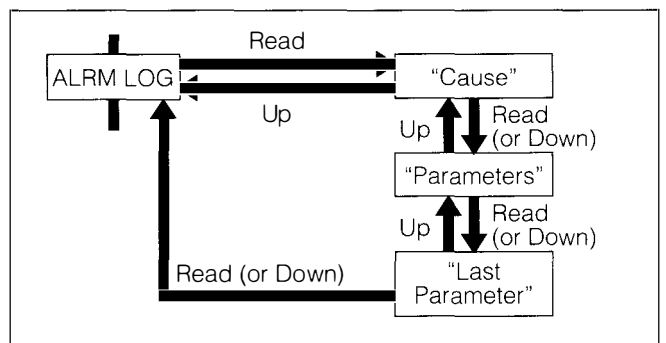

Reading the Alarm Log

Breaker Display Unit

Alarm Log Cause and Parameters Displayed

Alarm Cause	Message	Associated Measured Parameters
Overcurrent Over Ground Current Over Neutral Current Current Unbalance	OVER I OVER Ig OVER In I UNBAL	Ia, Ib, Ic, and if option present Ig, In
Communications Command	REMOTE	OPENED or CLOSED
Over Voltage Undervoltage Voltage Unbalance	OVER V UNDER V V UNBAL	Vab, Vbc, Vca, V**
Reverse Power Over Power	REVRs kW OVER kW	kW
Over kW Demand	OVER kWd	kWd
Over kVA	OVER kVA	kVA
Over kVAR	OVER kQ	kQ
Over/Under PF	PWR FCTR	PF
Over Frequency Under Frequency	OVER Hz UNDER Hz	Hz

If the BDU is connected to the trip unit when the alarm relay is activated, the event is immediately displayed. The "ALRM LOG" flashes on and off several times at 1-second intervals. The BDU then automatically starts displaying the cause and associated measured parameters. This sequence of flashing "ALRM LOG" and displaying alarm log values continues until any key is pressed, returning the display to manual control. Note that the alarm log has not been erased when returning to manual control and can again be read by manually scrolling to the "ALRM LOG" window.

Reading the Trip Log – From the "TRIP LOG" window, the most recent trip log event can be read by pressing Read to display the cause of the trip, followed by Read (or Down) to display the associated measured parameters. The display will return to the "TRIP LOG" window when the Read (or Down) key is pressed after the last parameter is displayed. Pressing Down or Up from the "TRIP LOG" window scrolls the display to the next window in the sequence. The cause and associated measured parameters displayed are given in the following table. The message "No Log" will be displayed if there is no tripping information available from the trip unit.

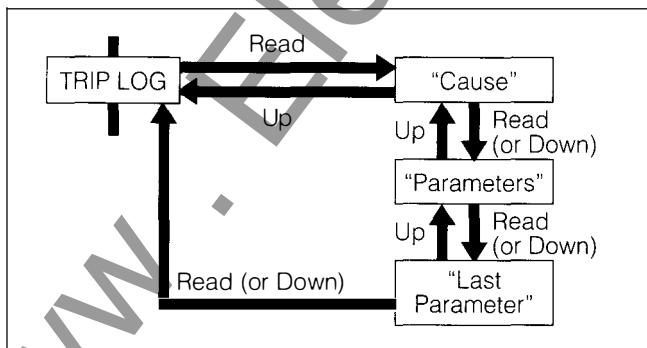

Reading the Trip Log

Trip Log Cause and Parameters Displayed

Trip Cause	Message	Associated Measured Parameters
Overload Short Time Instantaneous Ground Fault	OVERLOAD SHORT SHORT GROUND	Ia, Ib, Ic, and if option present Ig, In
Shadow	SHADOW	
Current Unbalance*	I UNBAL	Vab, Vbc Vca, V**
Communications Command	REMOTE	
Over Voltage* Under Voltage* Voltage Unbalance*	OVER V UNDER V V UNBAL	kW, kVA, kQ
Reverse Power*	REVRs kW	
Over Frequency* Under Frequency*	OVER Hz UNDER Hz	Hz, Vab, Vbc Vca, V**

Note: * indicates "X" option tripping functions

If the BDU is connected to the trip unit when the circuit breaker is tripped, the event is immediately displayed. The "TRIP LOG" flashes on and off several times at 1-second intervals. The BDU then automatically starts displaying the cause and associated measured parameters. This sequence of flashing "TRIP LOG" and displaying trip log values continues until the circuit breaker is closed or until any key is pressed. Closing the circuit breaker restarts the automatic data scrolling through the real-time measured values; pressing a key returns the display to manual control. Note that the trip log automatic flashing sequence takes priority over the alarm log automatic sequence.

Program Mode – The set-points for the alarms, thresholds, and delays are set in the program mode. They are protected with a password to prevent unauthorized changes. The password is not required to view the configuration and set-points. There is no automatic scrolling sequence in the program mode. However, if no key has been pressed for five minutes, the display will revert to Data mode and start its auto scrolling of real-time metered values.

Entering the Password – After entering the program mode and moving down (or up) in the scrolling sequence, the "PASSWORD" message is displayed. If the Down (or Up) key is pressed again, the display moves to the next message in the main scrolling sequence, but the configuration parameters and set-points cannot be changed; they can only be viewed. If the Enter (or Read) key is pressed, the four-digit password may be entered. This will allow the user to view and change the configuration and set-points.

The password is entered starting with the right-most digit. Flashing acts as a cursor to indicate the active digit (this manual will use an underline symbol to signify the digit which would be flashing). The Up and Down keys are used to scroll the numbers from 0 through 9. When the correct digit is displayed, pressing the Enter key enters the number and indexes the cursor to the next left digit. The digits not being activated are displayed as X's. After the last digit is entered, the word "Correct" or "Incorrect" will be briefly displayed. The BDU

Breaker Display Unit

Program Mode Main Scrolling Sequence

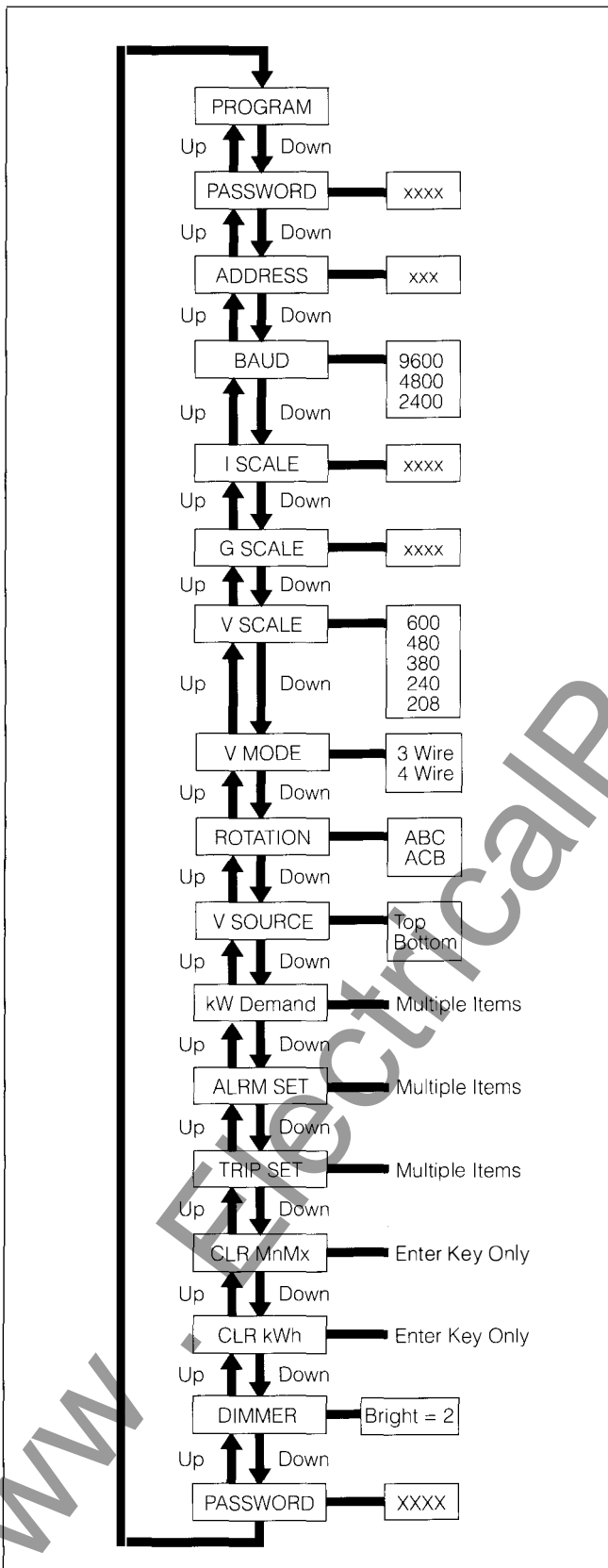

will then automatically return to the "Password" window. If the password is correct, the operator may both view and make changes. If the password is incorrect, the operator may try to enter the password again or may elect to only view set-points and configuration parameters. This example shows entering the password "5723".

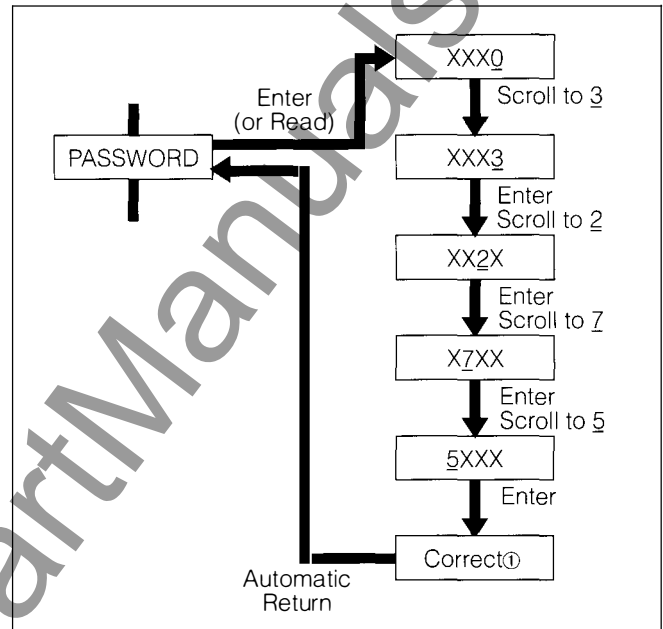

● The message "Incorrect" will appear if the wrong password has been entered.

The Password must be correctly entered to change configuration parameters and set-points. Contact your Siemens sales representative should you forget the correct password. Note that the password, as well as all other programmable parameters, is stored in the trip unit's internal memory, not in the BDU.

Changing the Password – The password can be changed once the current password has been entered. Changing the password requires two matching entries of the new password, as described below.

To change the password, enter the current password as noted in the section above, but this time press and hold the Enter key after the left-most digit has been keyed in. The message "Correct" will be displayed, followed within a few seconds by the messages "Change?" and then "New=XXX0". Now release the Enter key and enter the new password exactly as was done for the current password (note that releasing the Enter key before the "New=XXX0" message appears will cause the display to automatically return to the "PASSWORD" window). After keying in the left-most digit and pressing Enter, the message "ReEnter!" will appear followed a few seconds later by "NEW=XXX0" (The Enter key does not have to be held to automatically advance to this window). Reenter the new password. This time the message "Executed" will appear and the display will automatically return to the "PASSWORD" window. The password has now been changed. If the second entry of the new password does not match the first, the message "Canceled" will appear briefly, the display will automatically return to the "PASSWORD" window, and the original password will be retained. The example shows changing the password from "5723" to "2001".

Breaker Display Unit

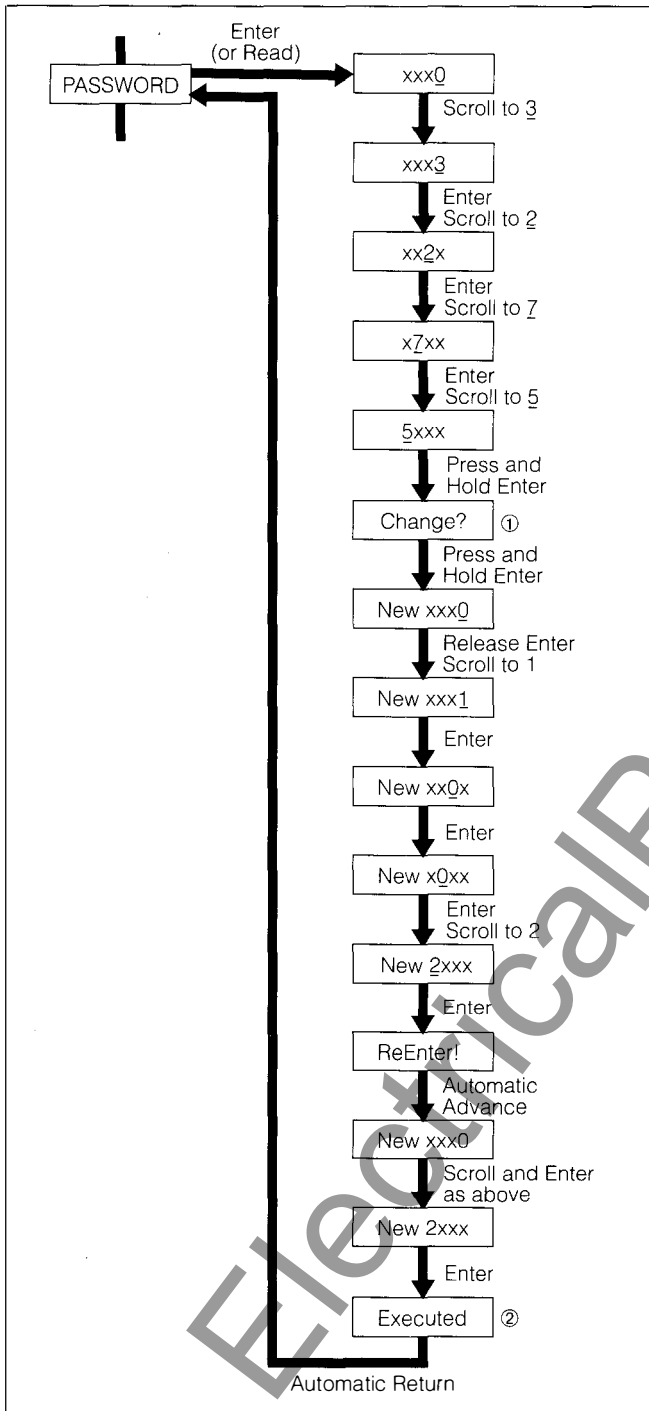

- ① The message "Incorrect" will appear if the wrong password has been entered and the display will automatically return to the "PASSWORD" window.
- ② The message "Canceled" will appear if the second entry of the new password does not match the first.

Changing the Password (example shows changing password from 5723 to 2001).

Viewing Configuration Parameters and Set-Points – All items except "kWDemand", "ALRMSET" and "TRIPSET" have a single parameter or set-point. To view a single parameter or

set-point item, use the Up or Down key to scroll to the desired item. Press Read to display the parameter or set-point. Enter returns the window to the main scrolling sequence.

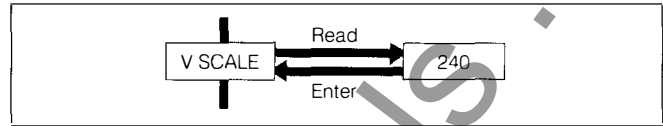

Read to display; Enter to return.

The kWDemand varies only slightly from the single parameter items in that there are two parameters listed; "LEN=" for the length of each period, and "NUM=" for the number of periods to complete the demand interval.

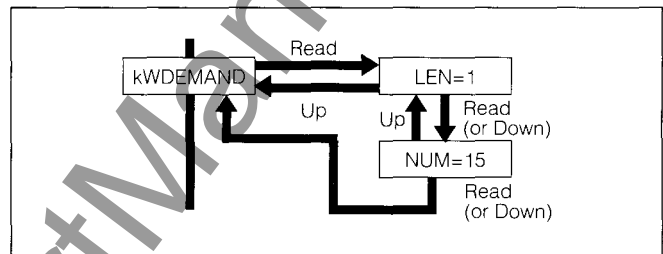

Viewing the kWDemand interval settings

"ALRMSET" and "TRIP SET" have several optional configuration parameters and set-points. To view an alarm parameter or set-point, scroll to the "ALRM SET" window. Press Read to display the alarm functions and scroll with the Down (or Up) key to the desired function. Note that functions that are programmed to activate the alarm relay or trip the circuit breaker are highlighted with a solid arrow ("◀"). With the desired function displayed, press Read to view the configuration parameters. Scroll down using the Read (or Down) key or scroll up using the Up key to view the threshold and delay settings. Continuing to press the Read (or Down) or Up keys will return the window to the alarm function. Pressing the Down or Up keys from the alarm function sequence will return the window to the main program sequence. Note that "N/A" will be displayed if a given option is not installed in the trip unit.

The same procedure is used to view the "TRIP SET" parameters and set-points. Note that some software version BDU's will display "S=" in place of "SET=".

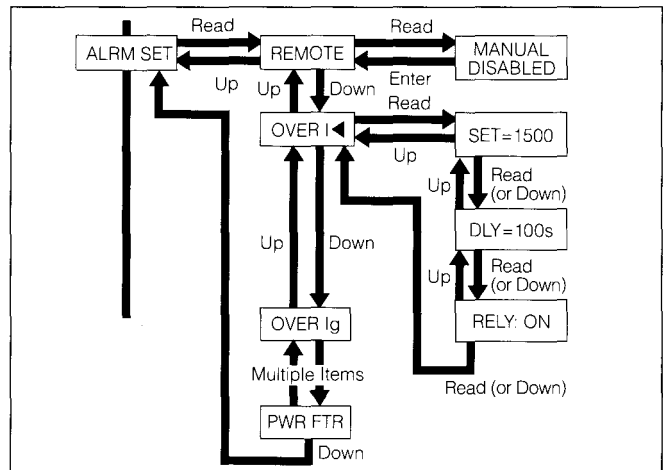

Viewing the Alarm Settings

Breaker Display Unit

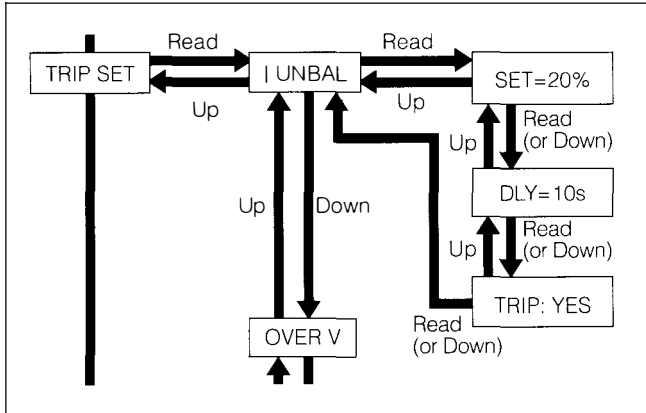

Viewing the Trip Settings

Setting Configuration Parameters and Set-Points – To change the setting of a single configuration parameter or set-point item, use the Down (or Up) key to scroll to the item in the main program sequence to be changed. Press Read to enter the parameter or set-point window. Some parameters and set-points are entered using the same procedure as was used to enter the password. The remainder are entered by scrolling to the desired displayed selection and pressing the Enter key.

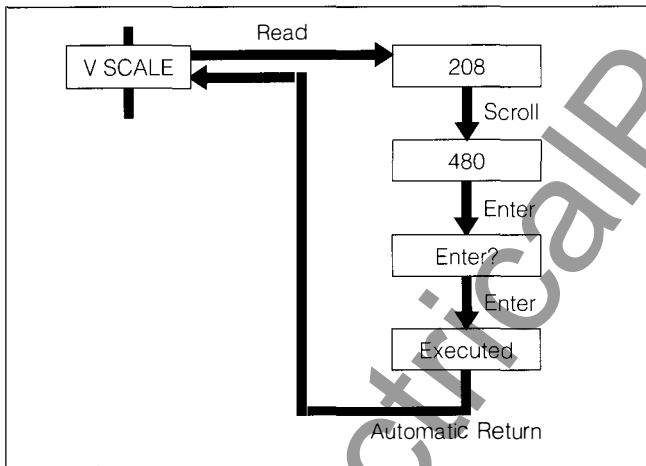

Scroll to desired selection; press Enter twice to confirm (Example shows changing V SCALE from 208 to 480).

To change the setting of an alarm or trip configuration parameter or set-point, use the Read and Down (or Up) keys to access the desired alarm or trip function. Then press Read to access the configuration sequence for the selected alarm or trip functions. Note that "N/A" will be displayed if a given option is not installed in the trip unit, and no set points can be programmed. Each window in this configuration sequence can now be changed using the Up or Down keys to scroll through digits or toggle through relay or trip options. Numbers are entered as is done for the password, starting with the right-most digit. After the left-most digit is keyed in (even if it is a blank or zero) and the Enter key pressed, the display will request confirmation with the message "Enter?". Press Enter again to change the configuration; any other key to abort the

change and retain the original setting. Pressing Read at any configuration window will advance to the next window without requiring digit-by-digit indexing and without changing the setting.

Alarm and trip settings can be cleared by setting configuration to "RELY:CLR" or "TRIP:CLR".

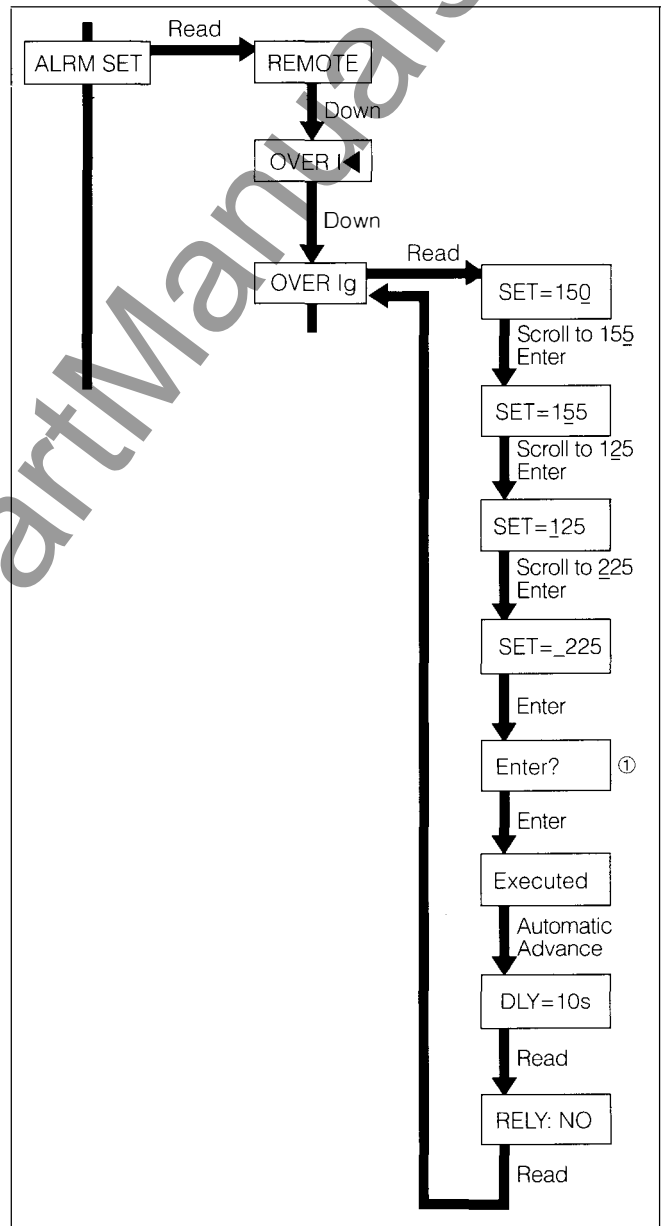

① Pressing any other key than Enter will abort changes and automatically advance to the next configuration window.

Changing the Alarm Settings (Example shows changing OVER Ig alarm set-point from 150 to 225).

Breaker Display Unit

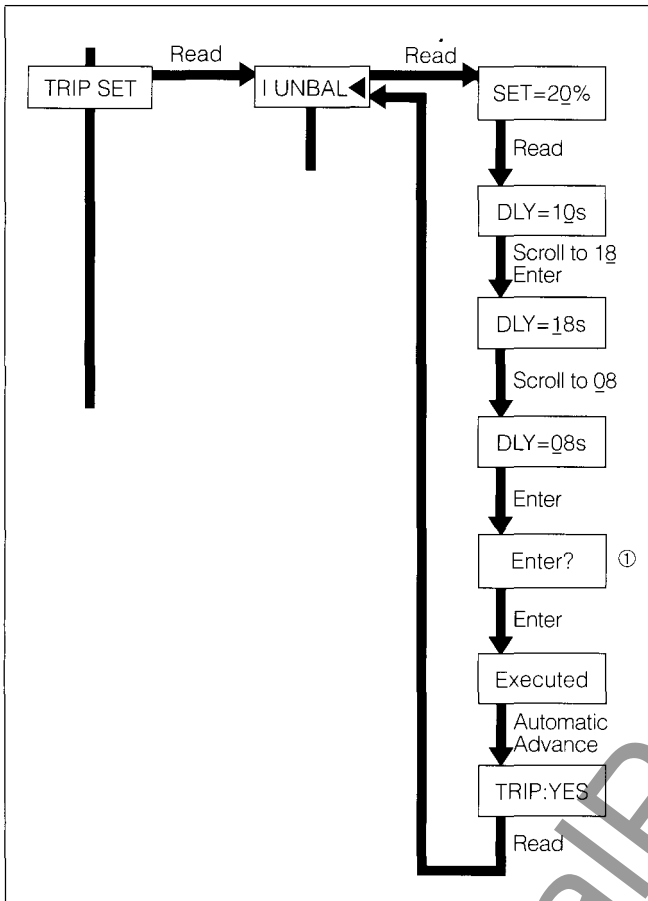

① Pressing any other key than Enter will abort changes and automatically advance to the next configuration window.

Changing the Trip Settings (Example shows changing I UNBAL delay from 10 to 8 seconds)

Clearing Min/Max and kWhr/kVARhr Values – The minimum/maximum values for all real-time measured parameters and the accumulated kilowatt and kilovar hours can be cleared after entering the correct password. To clear min/max values, use the Up or Down keys to scroll through the main program sequence to the “CLR Mn/Mx” window and press Enter. The message “Enter?” will appear requesting confirmation. Pressing Enter again will reset the min/max log in the trip unit’s non-volatile memory to the present values of each real-time measured parameter, and the message “Executed” will be briefly displayed before returning to the “CLR Mn/Mx” window. Pressing any other key will abort clearing of the min/max log and return to the “CLR Mn/Mx” window after a brief “Canceled” message is displayed. Resetting the kilowatt hour and kilovar hour registers to zero is accomplished from the “CLR kWh” window in the same way. Note that no action can be taken from these two program windows unless the correct password has been entered.

LED Display Brightness Control – The LED display brightness has been selected to meet a wide variety of ambient lighting conditions, and should not require adjustment. The LED brightness can be changed, however, to meet extreme lighting conditions if required. To vary the brightness, select the “DIMMER” window in the main program sequence and press Read to display the preset setting; shown as “Bright=2”. If the password has been entered, the Up and Down keys can be used to select brightness from 0 (brightest) to 6 (dimmiest). The LED brightness will immediately change as different numbers are selected. When the desired brightness is found, press Enter to return to the “DIMMER” window. Note that the new brightness number is stored in active memory in the BDU and will automatically return to the default value of 2 if control power is lost momentarily.

BDU Self-Test Function – The BDU has a self-testing feature which allows the operator to check for proper operation of all pixels (or dots) in the LED display, read the version numbers of the BDU and trip unit software, and read the catalog suffix number of the trip unit to indicate the metering and protective relaying function options which are installed. The self-test function can also be used to reset the BDU microprocessor in the unlikely event of a program execution error.

The self-test function is activated from any window by pressing the Up and Down keys at the same time and then holding them down as the display automatically scrolls through “Test?” followed by the LED pixel check “ ”. Releasing the keys will allow an automatic scroll indicating BDU RAM memory pass or fail, BDU ROM memory pass or fail, the BDU software version number (shown as “BDU:2.10”) followed by an indication of the installed metering and protection options and trip unit software version number (shown as “CNPX 2.24”) and an automatic return to the top of the data mode sequence

Breaker Display Unit

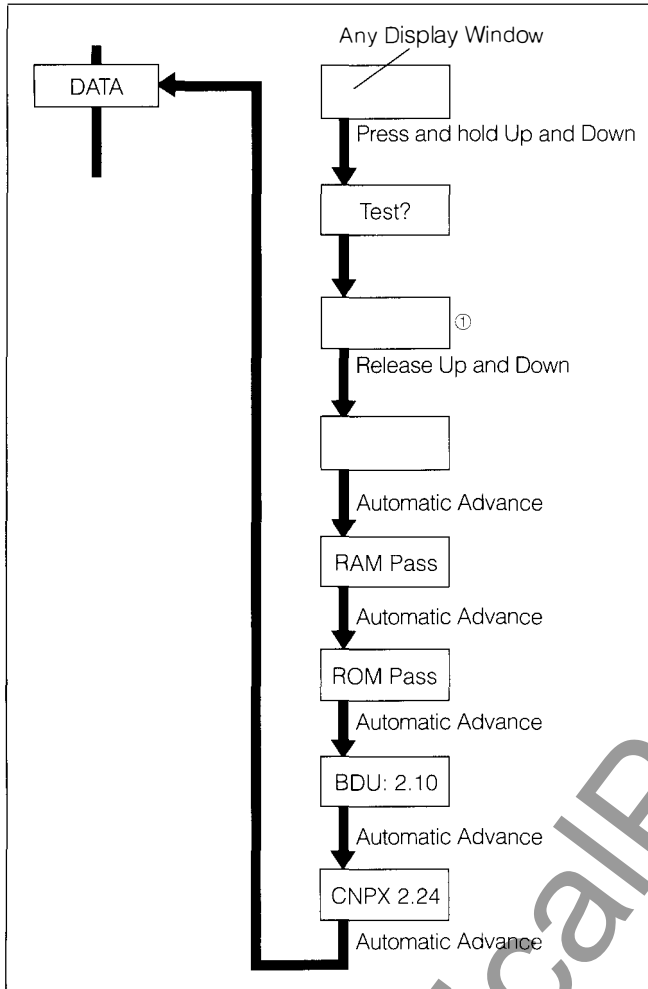

① Releasing the Up and Down keys before the pixel check display appears will automatically return to the initial window.

BDU Error Messages – The BDU constantly monitors the trip unit for information and is able to provide some diagnostic information as well as range and configuration checking. The table below summarizes the messages which may be displayed along with a brief explanation of their meaning.

Error Message	Cause of Error
No Ack 1	Hardware problem with the communications line between the BDU and the trip unit
No Ack 2	No response or incorrect response from the trip unit due to software or electrical interference on the communication line between the BDU and trip unit.
No Ack 3	Execution of command from the BDU not properly confirmed by the trip unit.
Config Er	Configuration error between BDU and trip unit programmed values
Range Er	Value out of permissible range
Unknown	The BDU cannot interpret the alarm log, trip log or other information requested from the trip unit.

Accessories

Zone Interlocking Components

Static Trip III trip units with the "-TZ" suffix are capable of being connected together into a zone interlocking system. Zone interlock expanders and couplers are used for connections between Static Trip III trip units. Multiplexer/Translators are used for connections between Static Trip III units and Sentron Series molded case or SB insulated case circuit breakers with zone interlocking capability (for additional information refer to the Multiplexer Translator Information and Instruction Guide, bulletin number 2.21-1A).

Zone Interlock Expanders

Two zone interlock expander models are available for use with Static Trip III units to connect a single upstream circuit breaker to multiple downstream circuit breakers. One model includes a cable for direct connection to the upstream trip unit's sub "D" connector; a second version provides for additional inputs from downstream trip units. Each expander has 6 optically-isolated input channels for connection to downstream trip units. Each expander also includes a set of parallel output terminals for connecting the zone interlock signal to an expander farther upstream. No external power supply is required.

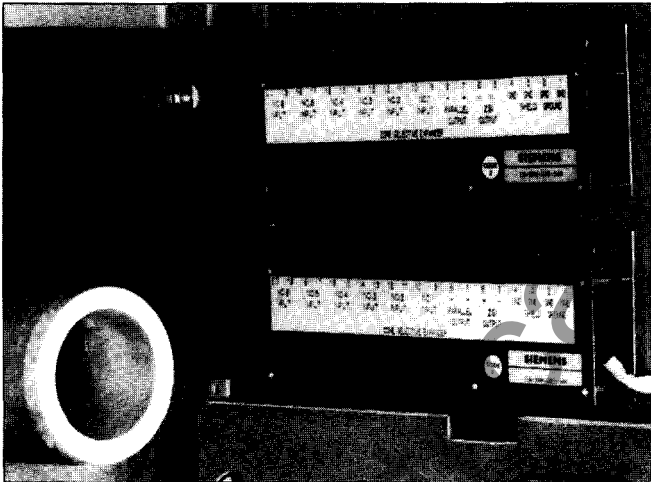

Zone Interlock Expanders

Zone Interlock Coupler

The zone interlock coupler is used to connect a single trip unit into a zone interlock system, and includes a cable for direct connection to the trip unit's sub "D" connector. The coupler also has one optically-isolated input and one output channel. The input channel may be used to connect to another coupler associated with a downstream trip unit. The output channel may be used to drive up to two upstream coupler or expander input channels connected in parallel. No external power supply is required.

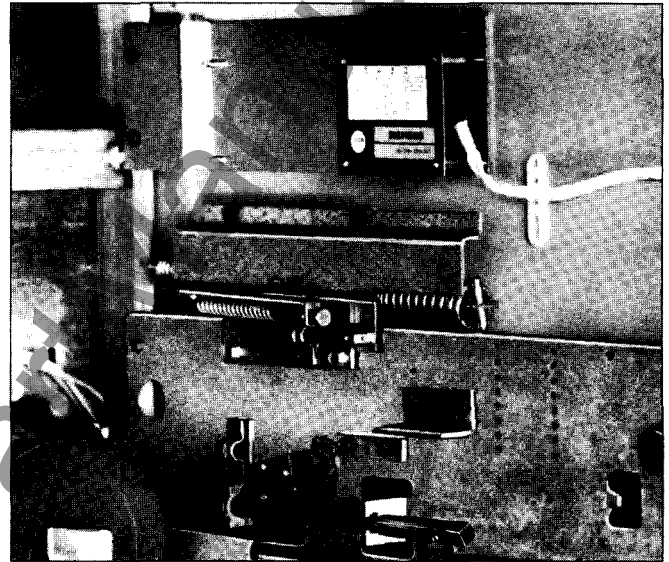

Zone Interlocking Coupler

Sealable Transparent Cover

The transparent cover is used to help prevent tampering with the overcurrent protection adjustments. The cover is held in place over the face of the trip unit with two screws. Holes in the screws allow the cover to be secured in place with a wire and lead seal. When the cover is in place, the overcurrent protection adjustments are not accessible.

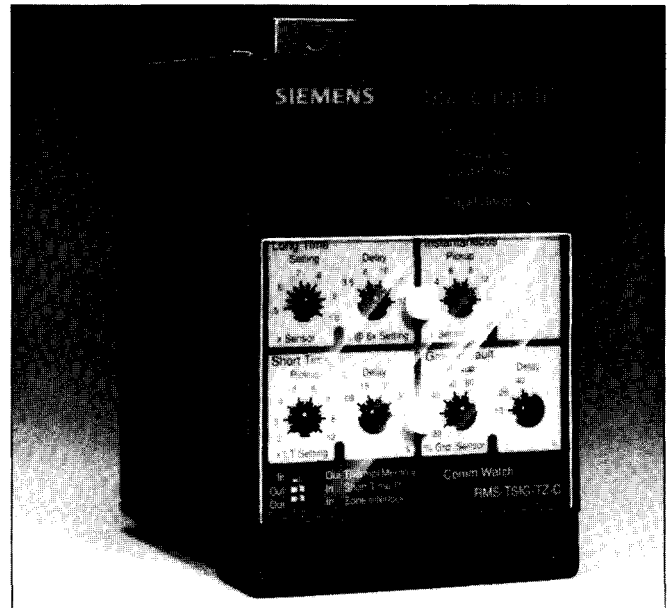

Static Trip III with Transparent Cover

Accessories

Power Supplies

Static Trip III C/CP/CPX model trip units require external 15V dc control power for the communications microprocessor. Three power supply models are available with sufficient volt-ampere capacity for up to 2, 8 or 16 trip units. Because BDUs require the same amount of power as communicating trip units, you must count both BDUs and trip units when determining the power supply capacity you need. For example, the power supply with a capacity for eight trip units can only support four trip units if you attach a BDU to each trip unit. The power supplies have 120V ac/125V dc input and typically mount in an instrument compartment.

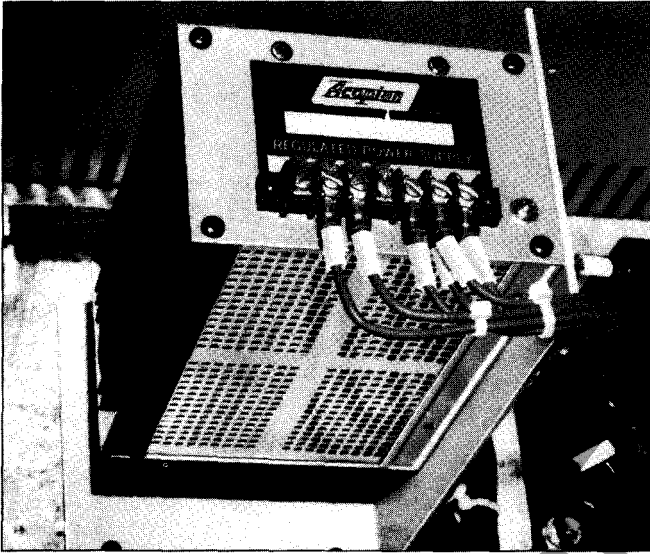

Typical power supply mounted in instrument compartment

Portable Test Set - Type PTS4

Siemens' portable test set type PTS4 is designed for testing Static Trip III trip units. The test set provides a means of testing the magnetic tripping actuator as well as the trip unit. The portable test set, using power from an ordinary 120 volt convenience outlet, can provide circuit breaker testing equivalent to much more expensive and cumbersome primary current testing. The instructions for testing the Static Trip III with the PTS4 were presented in the Testing section. For additional information see Portable Test Set - Type PTS4 Instruction Guide SG-3138.

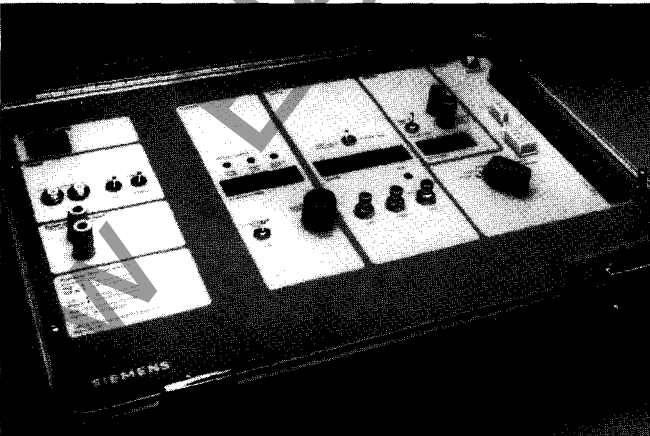

PTS4 Portable Test Set

Communications Secondary Disconnects

A specially-designed communications secondary disconnect assembly is used for Static Trip III C/CP/CPX trip unit's communications, 15V dc control power and alarm signals. This communications disconnect has gold plated contacts for reliable electrical connection. The communications disconnect is self-aligning and makes contact in the connected position only. Cubicle and breaker assemblies are available for upgrades to Type RL circuit breakers, for use by OEM's or for retrofit applications.

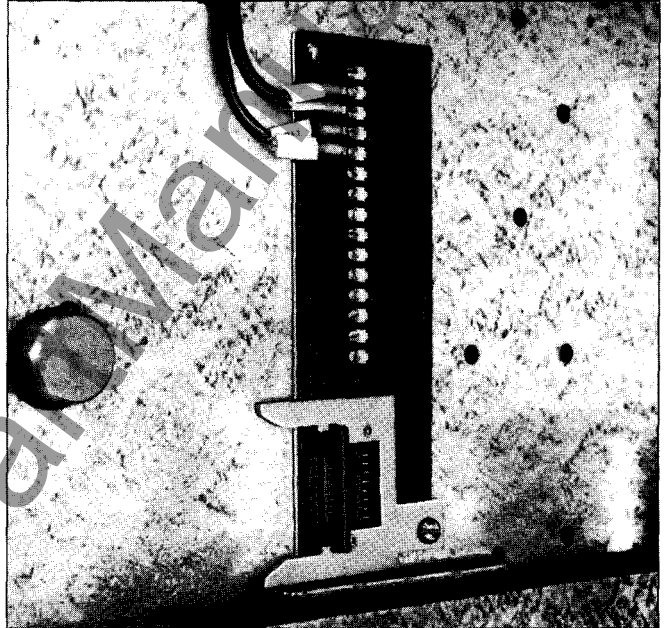

Cubicle Disconnect in Type RL circuit breaker compartment

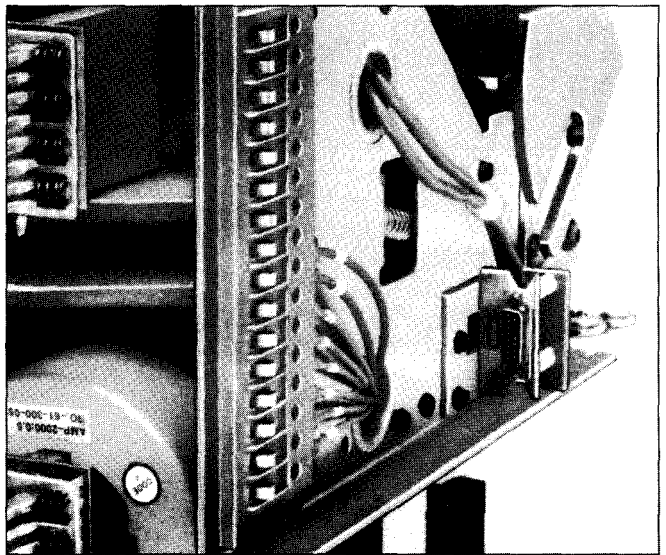

Breaker Disconnect on Type RL circuit breaker

Accessories

Breaker Position Switch

A spring-loaded switch is used for circuit breaker open/closed position input to Static Trip IIIC/CP/CPX trip units. The switch assembly is designed for simple mounting to Type RL circuit breakers, but can be used for retrofit to other circuit breakers as well. The switch is wired to the trip unit as a 52b contact so that an open connection will appear as a closed breaker.

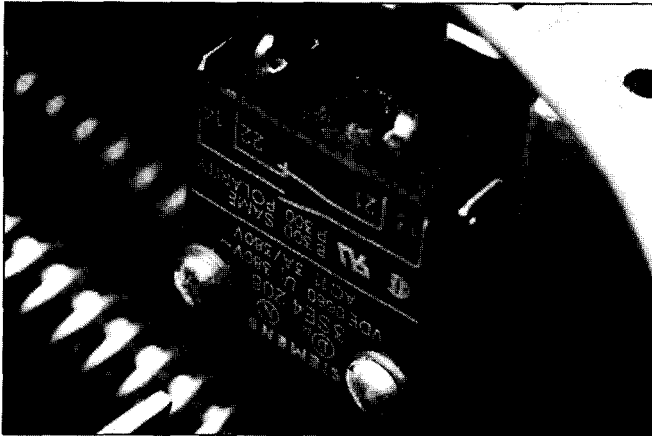

Position switch mounted on Type RL circuit breaker

Interposing Relay

An interposing relay is required to integrate the Static Trip IIIC/CP/CPX model trip units' 100mA 12V dc Output 1 signal into alarm or control schemes. The interposing relay provides a 1A 120V ac/125V dc normally open solid state contact and can be mounted in the circuit breaker compartment.



Interposing Relay mounted in Type RL circuit breaker compartment.

Potential Transformers

Two potential transformer models are available for use with power metering version Static Trip III devices. The catalog number PTM-A is designed for integral mounting on type RL low voltage power circuit breakers; the PTM-B uses a more general purpose mounting which is better suited for retrofit applications. Kits are available which include the PT module, wire and primary fuse assemblies for upgrading Type RL, circuit breakers or installation on other manufacturers equipment.

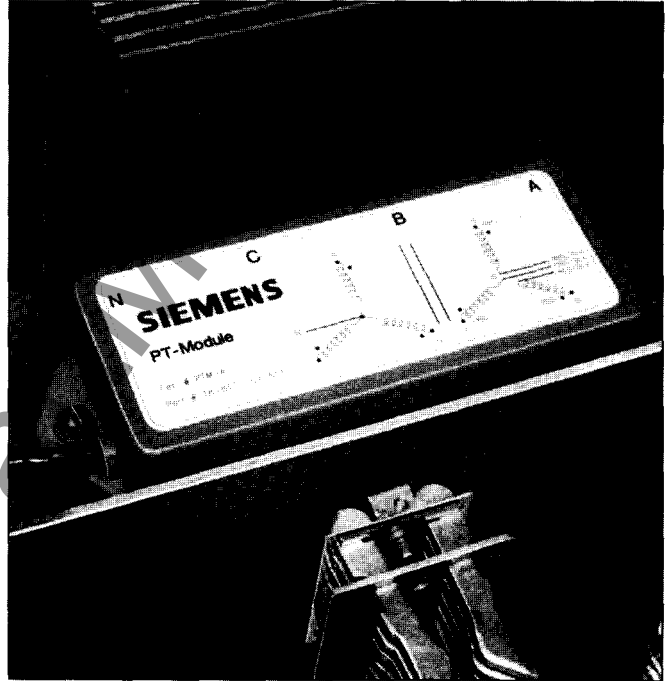

Installed Potential Transformer on Type RL breaker

Ordering Information

Single Winding Current Sensors Part Numbers 61-300-053-

Current Rating	Part Number Suffix	Frame Ratings
150A	501	800A/1600A/2000A
200A	502	
300A	503	
400A	504	
600A	505	
800A	506	
1200A	507	1600A/2000A
1600A	508	
2000A	509	2000A
1200A	510	3200A
1600A	511	
2000A	512	
2400A	525	
3000A	526	
3200A	513	
1600A	514	4000A
2000A	515	
3200A	516	
4000A	517	

Dual Winding Current Sensors with Separate 2000A Ground Sensor Winding Part Numbers 61-300-059- (Meets NEC Article 230-95 Service Entrance Requirement)

Current Rating	Part Number Suffix	Frame Ratings
2000A	509	2000A
1200A	501	3200A
1600A	502	
2000A	503	
3200A	504	
1600A	505	4000A
2000A	506	
3200A	507	
4000A	508	

Tapped Current Sensor Part Numbers 61-300-065- (Taps at 25%, 50% and 75% of Sensor Current Rating)

Current Rating	Part Number Suffix	Frame Ratings
800A	501	800A
1600A	502	1600A/2000A
2000A	503	2000A
3200A	504	3200A
4000A	505	4000A

Neutral/Ground Current Sensor with Integral Conductor^① Part Numbers 18-811-676-

Current Rating	Part Number Suffix	Frame Ratings
800A	506	800A/1600A/2000A
1200A	507	
1600A	508	
2000A	509	
1200A	516	3200A/4000A
1600A	517	
2000A	518	
2400A	521	
3200A	519	
4000A	520	

^① Breaker mounted current sensors (61-series part numbers) can also be used as neutral/ground sensors where the integral conductor is not required.

Tripping Actuator 18-809-575-504

Zone Interlocking Components

Coupler with connector cable 18-658-143-544
 Expander with connector cable 18-658-143-545
 Expander without connector cable 18-658-143-546

Sealable Transparent Cover 18-658-574-882

Power Supplies

For up to 2 communicating trip units* 18-658-143-549
 For up to 8 communicating trip units* 18-658-143-550
 For up to 16 communicating trip units* 18-658-143-551

* Because BDUs require the same amount of power as communicating trip units, you must count both BDUs and trip units when determining the power supply capacity you need. For example, the power supply with a capacity for eight trip units can only support four trip units if you attach a BDU to each trip unit.

Communications Disconnects

Cubicle Disconnect 18-658-143-547
 Circuit Breaker Disconnect 18-658-143-548

Breaker Position Switch 00-000-466-771

Interposing Relay 18-658-143-552

Potential Transformer Modules

PTM-1 Kit for RL breakers 18-487-906-501
 PTM-2 Kit for Universal Mounting 18-487-910-501

Breaker Display Unit

BDU - replacement unit only 18-658-582-544
 BDU Cable Assembly only 18-658-582-546
 RL 800 to 2000 Upgrade Kit* 18-818-334-501
 RL 3200 to 4000 Upgrade Kit* 18-818-335-501

* includes prewired circuit breaker cover, BDU and cable

Portable Test Set - PTS4 18-473-254-502

Training Video Tape for PTS4 V003

Static Trip III Retrofit Kits Consult factory

Neutral Current Sensors with Separate 2000A Ground Sensor Winding and Integral Conductor^① Part Numbers 18-811-676-

(Meets NEC Article 230-95 Service Entrance Requirements)

Current Rating	Part Number Suffix	Frame Ratings
1200A	522	3200A/4000A
1600A	523	
2000A	524	
3200A	525	
4000A	526	

Ordering Information

Static Trip III Part Numbers

Static Trip III trip units are identified by an 11 digit part number (18-483-905-xxx). The last three digits in the part numbers identify the trip units' functional characteristics.

Static Trip III Trip Unit Part Numbers 18-483-905-

Cat. No. Prefix	Overcurrent Tripping Functions	No Communication (No Suffix)	Communications					
			-C	-CN	-CP	-CNP	-CPX	-CNPX
RMS-	TI-T	504	510	516	522	528	546	552
RMS-	TS-TZ	505	511	517	523	529	547	553
RMS-	TSI-TZ	506	512	518	524	530	548	554
RMS-	TIG-TZ	507	513	519	525	531	549	555
RMS-	TSG-TZ	508	514	520	526	532	550	556
RMS-	TSIG-TZ	509	515	521	527	533	551	557
			Neutral Metering			Power Metering		
						Neutral Metering		Extended Protection
						Neutral Metering		

Static Trip III R Part Numbers (Retrofit Version)

Static Trip III R retrofit version trip units are identified by an 11 digit part number (18-486-475-xxx). The last three digits in the part numbers identify the trip units' functional characteristics, and are identical to the three digit coding used for the standard package.

Static Trip III R Trip Unit Part Numbers 18-486-475-

Cat. No. Prefix	Overcurrent Tripping Functions	No Communication -R	Communications					
			-C-R	-CN-R	-CP-R	-CNP-R	-CPX-R	-CNPX-R
RMS-	TI-T	504	510	516	522	528	546	552
RMS-	TS-TZ	505	511	517	523	529	547	553
RMS-	TSI-TZ	506	512	518	524	530	548	554
RMS-	TIG-TZ	507	513	519	525	531	549	555
RMS-	TSG-TZ	508	514	520	526	532	550	556
RMS-	TSIG-TZ	509	515	521	527	533	551	557
			Neutral Metering			Power Metering		
						Neutral Metering		Extended Protection
						Neutral Metering		

NOTE: Early model Static Trip III trip units supported the load indicator accessory and had a medium gray faceplate. These units are no longer in production, however 18-483-905-xxx part numbers above with similar functional characteristics can be substituted. Consult factory if support for an existing load indicator accessory is required.

Ordering Information

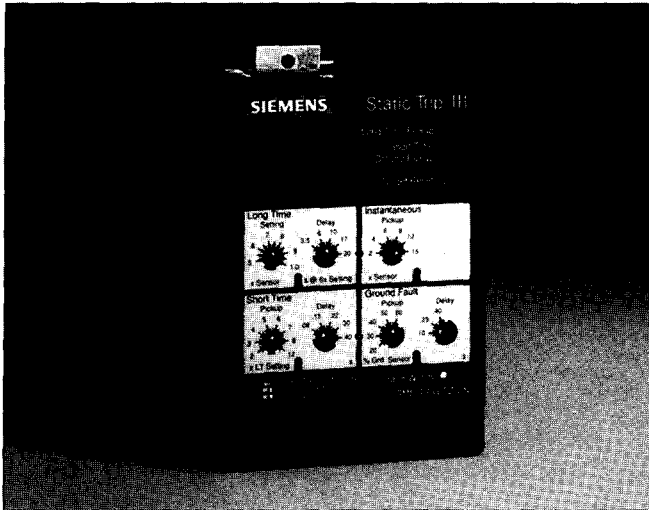

Standard Package for Mounting on Type RL Circuit Breakers

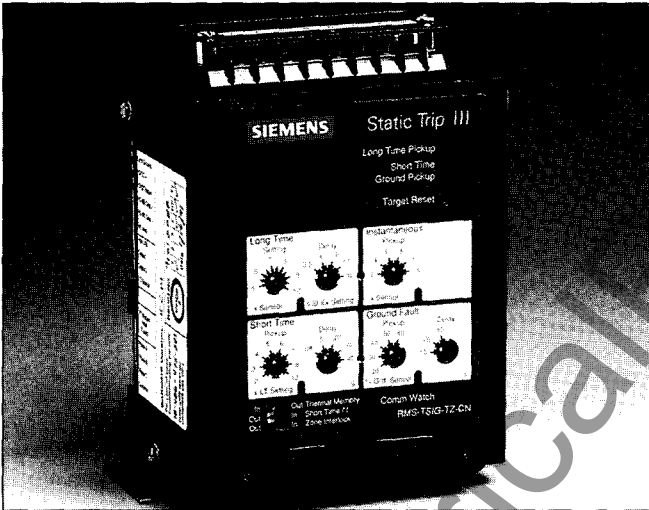

Retrofit Package for Universal Mounting



Obsolete Version

Trip Unit Catalog Number Definitions

The letters following the RMS at the lower right of the front of a Static Trip III trip unit identify the specific functional characteristics of the device. The definitions of the letters are as follows:

Static Trip III Catalog Number Definitions

RMS - T S I G - T Z - C N P X - R

Basic Product Designations:

- T = Long Time with switchable thermal memory
- S = Short Time
- I = Instantaneous
- G = Ground Fault

LCD Targets/Watchdog Circuit

Zone Interlocking Capability
(Automatically supplied with Short Time and/or Ground Fault)

Communications Capability

Options Available With Communications:

- N = Neutral Current Metering
- P = Power Metering
- X = Protective Relaying

Retrofit Package for Universal Mounting
(not included as part of the front label identification)

SIEMENS

Siemens Energy
& Automation, Inc.

P.O. Box 29503
Raleigh, NC 27626-0503

www.ElectricalPartManuals.com