

Westinghouse

Type G-40

Recording Instruments

INSTRUCTIONS

GENERAL

The type G-40 recording instruments should be installed where they will not be subjected to excessive vibration, dust, moisture or variations in temperature. In general, good indicating instrument practice should be followed, with additional regard to the fact that temperatures below freezing will interfere with the flow of ink.

The design of the type G-40 recording instruments obviates the need for excessive clearance from neighboring instruments when mounting on a switchboard. As little as one-half inch on each side of type G-40 is sufficient clearance to allow plenty of room for changing gears, winding clock, inking, etc., because of the titling paper carriage construction.

When mounting on metal panels with the associated shunts, reactors and resistors when required, keep in mind the insulation rating specified for these various accessories. Type G-40 recording instruments are tested for use on circuits up to and including 750 volts.

Type G-40 recorders are well shielded against stray fields, the "External field influence" being less than $\frac{1}{4}$ per cent. External fields stronger than 5 oersteds should be avoided.

INSTALLATION

Unpacking

Unpack carefully. Be sure that all small accessories, spare parts, etc., are found before discarding the packing material. Preserve the packing case for use in the future, whenever it may be necessary to either store or reship the instrument.

For list of accessories supplied with each recorder see page 9.

Mounting

Carefully observe the following directions and execute them in the order in which they are given:

- Thoroughly familiarize yourself with all the information in this instruction book.
- For panel mounting, drill the panel according to the drilling plans in this leaflet. When mounting, see that the instrument is level.

- Mount the instrument upon the switchboard or other support, using a level to insure its being placed in a vertical position both parallel and perpendicular to the board. The support should be as free as possible from vibration.

- Trace out all external electrical connections carefully and connect according to the proper diagram. Except in the case of portable instruments, all diagrams are made showing the connections as they appear from the rear of the board unless specifically indicated otherwise. The cover is held in place by four thumb screws, which release quickly when turned, due to their quadruple threads.

Remove cover and tilt the paper driving unit forward as shown in Fig. 4. The unit is held in position by a latch which must be released by means of the lever at the upper end of the right hand side plate. If desired the complete chart mechanism may be removed, while it is in the forward position.

Removing the Pen

It is advisable to remove the pen before proceeding further.

The moving element incorporates a removable arm on which the pen is located. To remove the pen, press the flat springs apart.

Release the spring mounting and movement locking mechanism, in the G-40 type by turning the locking nut shown in Fig. 5. The movement must always be locked before transporting an instrument.

Make a general mechanical inspection to see that rough handling in shipment has not damaged any parts of the instrument.

Inserting the Chart

The paper driving unit being in the forward position as shown in Fig. 4, the unused roll of paper is placed in the upper receptacle at the rear of the unit as shown in Fig. 2. Unroll a short length of the paper, and feed it carefully

under the chart roller and guards over driving drum pins; by pressing the paper on this drum, it can be forced to rotate through the friction clutch, without driving the timing mechanism. Continue to roll the paper on the drum until the end of the paper extends about eight inches below the recorder. Crease the paper squarely across, about one-half inch from the edge, and fold it in so that the smooth folded edge is away from the recorder. Remove the re-roll spool by pressing the right-hand spring stop to the right and lifting out the spool. Thread the folded paper into the re-roll spool slot, and wind on a few turns of paper. Insert the re-roll spool on the re-roll drive pulley at the left, rotating if necessary to engage the drive means, and press the right-hand end of the spool in place. Both spools rotate clockwise when viewed from the left-hand side of the recorder.

Starting the Clock

On the spring clock, there is a small lever by which the mechanism can be started or stopped. Move the lever "up" to stop, and press it "down" to start the clock.

For the synchronous motor, a small separable plug and socket serve to disconnect and stop the motor when desired.

Clocks may either be hand-wound eight-day spring-driven type, or the synchronous motor type. The clock provides the power for driving the strip chart. Either form of clock can be set to drive the paper at normal speeds of $\frac{3}{4}$, $1\frac{1}{2}$, 3, or 6 inches an hour. The various speeds just mentioned are made possible by using appropriate sets of gears furnished with the instrument. These gears are held in place by a thumb nut, both when stored on the lower side of the chart mechanism, and also when in use, one at a time, at the left of the clock mechanism. When inserting the gears, required for the paper chart speed desired, take care to align the slot with the shaft pin before pressing the gear into place. The chart speed produced by each gear is stamped on its face.

TYPE G-40 RECORDING INSTRUMENTS—Continued

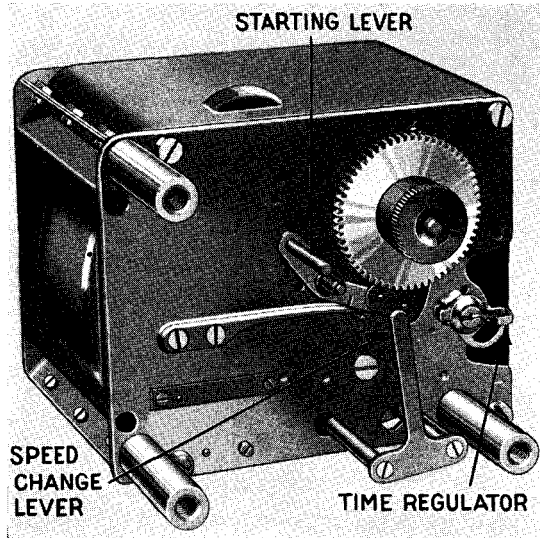

FIG. 1—SPRING DRIVEN HAND WOUND EIGHT-DAY CLOCK

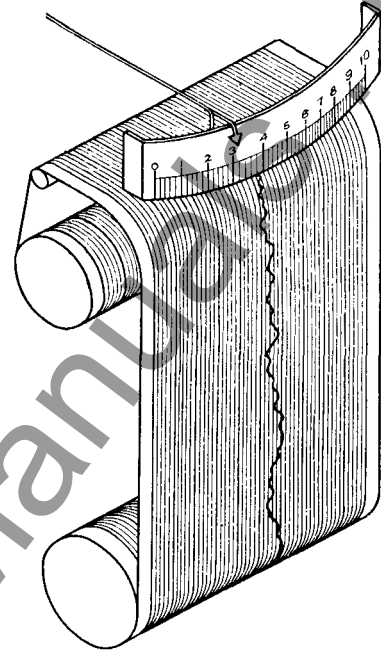

FIG. 2—SCHEMATIC VIEW, PAPER ROLL FEED

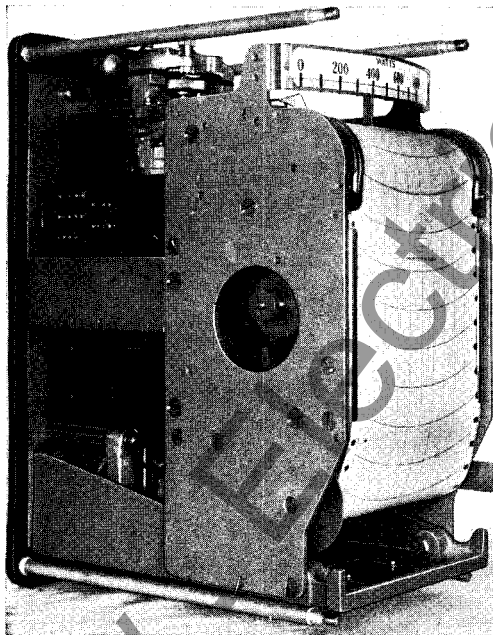

FIG. 3—GY RECORDER WITH CHART MECHANISM IN OPERATING POSITION

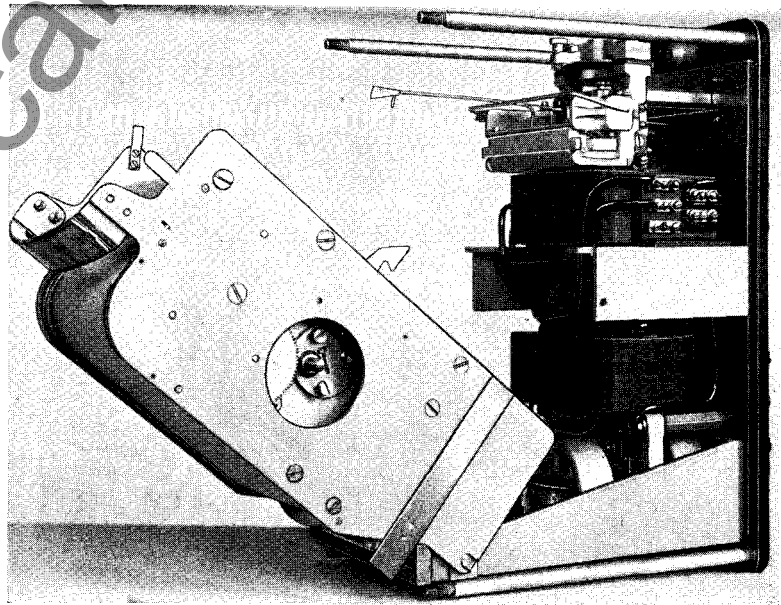

FIG. 4—GY-40 RECORDER WITH COVER REMOVED

TYPE G-40 RECORDING INSTRUMENTS—Continued

A high speed, sixty times as fast as the normal speed (inches per minute instead of per hour), is available by shifting the speed lever. This gives chart speeds of $\frac{3}{4}$, $1\frac{1}{2}$, 3, and 6 inches a minute.

The synchronous motor, when supplied with well-regulated a-c. power supply, drives the chart accurately at either high or normal speeds. The high speed of the spring clock is intended for short tests and is not a precision timing device. The spring clock, at normal speed, utilizes a jeweled escapement, while for high speed, a double fly-ball governor is used. The normal speed of the spring clock is as accurate as any well-made clock, and can be regulated for "fast" or "slow" in the usual manner of such clocks.

Filling Pen and Inkwell

The pen having been previously removed, remove the cast alloy ink-well by lifting its front and sliding directly out. Use the special ink as specified on label of the bottle, and fill the ink-well to within about one-sixteenth of an inch of the opening, using the ink-well filler for this purpose. (The filler should not be submerged in the ink-well during filling, as bubbles may become entrapped in the ink causing stoppage of the feed through the pen.) Replace the ink-well, then put the pen in place, and fill the pen using the rubber pen-starter. The pen is of the capillary tube type and therefore must be primed before it will start marking. This is done by inserting the front tip of the pen in the little hole in the pen-starter. This hole is at right angles to the conical tube projecting from the rubber bulb. With the pen point in the pen-starter, and the other end of the pen dipping in the filled ink-well, first press the bulb and then release it, to draw ink into the pen. With the pen tube full of ink, the moving arm should be balanced so that the pen tip rests lightly but definitely on the paper. If the point rests too heavily on the paper, excessive friction results, decreasing the accuracy of the recording, while if the point rests too lightly, an unsatisfactory marking will result. The adjustment is readily made, when required, by sliding the helical balance weight on the tail-piece of the pen.

Caution:—when shipping or transporting remove all ink from the well to

avoid possibility of spilling on mechanism.

Setting Zero

After the paper driving unit is restored to its normal position, and the paper chart is inserted, the zero can be set with power off or with the instrument disconnected. It is preferable to set the pen point to zero on the paper chart, rather than on the indicating dial. A knurled stud, located above the moving element, actuates a pinion and gear which control the upper spring of the moving element. See Fig. 5 for position of zero adjuster.

See that the moving element returns to zero freely when deflected slightly forward and backward by hand. The ink should be flowing as it has a tendency to reduce the friction at the pen point.

If the connections have been opened for adjusting zero, reconnect the instrument to the circuit. (Remember that connections to current transformers must never be opened while current is flowing.)

Adjusting For Time

The paper chart is operated by the clock through a friction clutch drive. To set the chart for the right time, turn the chart roller and chart forward to the correct time by hand.

If it is desired to turn the chart backward for more than a few inches, it will be necessary to tilt the paper driving unit forward again and rewind some of the paper upon the paper supply spool.

The date of the starting may be marked in pencil on the chart, together with any other useful notations.

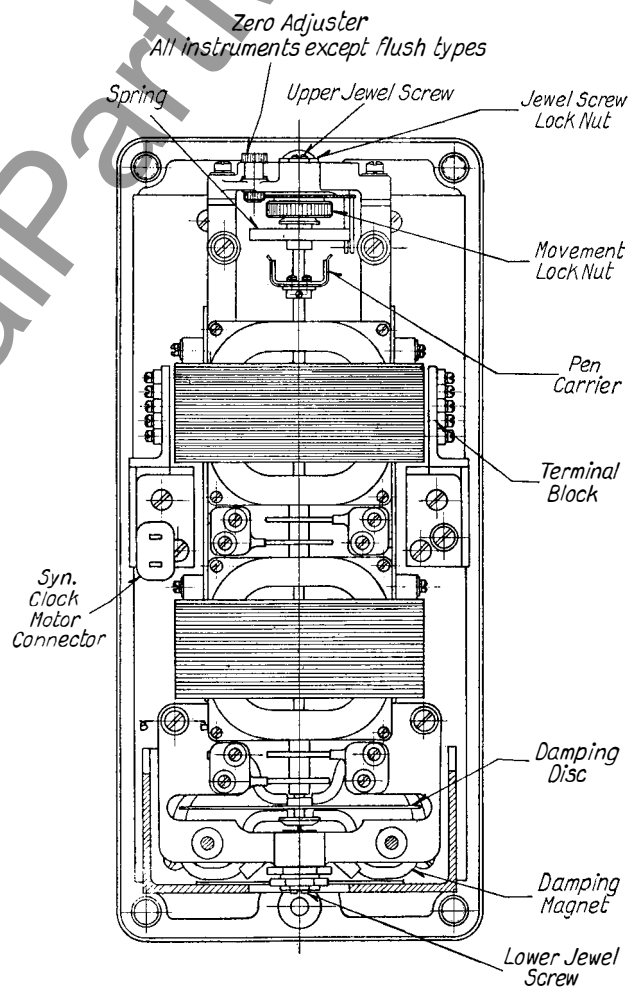

FIG. 5—PRINCIPAL PARTS AS DESCRIBED IN TEXT, VIEW SHOWS POLYPHASE WATTMETER OR INSTRUMENT

TYPE G-40 RECORDING INSTRUMENTS—Continued

MAINTENANCE

Type G-40 recording instruments are carefully designed and manufactured, and will require a minimum of maintenance under reasonable service conditions.

Ink and Inking System

The ink supplied has been carefully developed for this purpose and tested over a period of years, for the particular requirements of these recorders.

If the recorder has been out of service for some time, the ink reservoir should be thoroughly washed with water or alcohol, and refilled with fresh ink. If the recorder is to be taken out of service for any appreciable time, the pen and ink-well should first be thoroughly flushed out and cleaned with alcohol or water.

The pen is a capillary silver tube with a special platinum-iridium tubular point. The rubber bulb pen-starter can be used either to fill or clean the pen, while the tiny cleaning wire furnished is the best way to clear the small hole in the tubular pen point. After cleaning and refilling the pen, it should be checked for balance. If the marking edge becomes rough, it should be carefully rehone to a smooth surface with a slightly rounded edge to avoid scratching the record chart.

Paper Drive

The main driving drum pulley has a smooth groove, while the re-roll pulley has a knurled groove. The spring wire belt connecting these pulleys remains in place even when the re-roll spool is removed for the insertion of paper. The tension of the driving belt is not critical, and the combination of the smooth and grooved pulleys, with the single-clock mechanism, allows the re-roll to collect an entire roll of paper.

Clocks

Spring Wound Clock—In common with ordinary high grade clocks these recorder clocks must be occasionally cleaned and oiled.

It is recommended that any necessary cleaning and oiling be done by a first-class local jeweler or instrument maker. The clock mechanism is easily removed for cleaning or repair by taking out

three machine screws at the left of the paper carriage.

Clock bearings may be cleaned by brushing out with naphtha or clock cleaning fluid. After being thoroughly dried, the bearings should be lubricated with a high grade clock oil such as Westinghouse Clock Oil S# 935736. This oil comes in 2 ounce bottles. The main spring should be lubricated by injecting some petrolatum (vaseline) or Westinghouse Lubricant S# 821360 between the convolutions when the spring is not wound up.

The timing regulation of hand wound clocks is accomplished in exactly the same way as for ordinary balance wheel clocks or watches.

Synchronous Clocks — Synchronous clocks are self-starting and do not require any regulation. They are only applicable with accuracy to circuits having frequency regulation, to the frequency for which the clock is designed. The clock train of gears should be occasionally cleaned and lubricated as above indicated for spring driven clocks.

Permissible voltage variation is from 80 to 115% of nominal voltage rating.

CALIBRATION

The accuracy of recording instruments can be checked by comparing them with known standards in the same manner as indicating instruments.

The calibration of recording voltmeters, ammeters and wattmeters can be varied by changing the location of outer ends of the spring in the spring clamp over a range of about plus or minus 5%. Increasing the active length of the spring increases the reading for a given setting of the standard. The spring clamp is shown in Fig. 5.

In general the calibration is performed in the same way as for indicating instruments, using portable standards of known accuracy, such as the PX-5 or PY-5 instruments. An adjustment for scale distribution consists of moving the pen arm with respect to the coil. In case movements are repaired the originally calibrated angles must be restored as follows:

A-C. Ammeters—pen 18 degrees in advance of moving coil.

A-C. Voltmeters—pen 15 degrees in advance of moving coil.

A-C. Wattmeters—pen in line with coil.

D-C. Instruments—pen in line with coil.

In the A-C. ammeters, the moving coil is connected across the stationary coil with a reactor-resistor network to give proper current distribution with variations in frequency. If after adjusting the pen arm position the calibration does not match the chart lines throughout, the procedure as follows:

1. Adjust full scale at 60 cycles, by means of spring.
2. If instrument reads low on D-C., reduce resistance of the spool in series with the moving coil, or vice versa.
3. Recheck on 60 cycles, readjusting the spring if necessary.

The calibration of voltmeters and wattmeters can also be varied by re-adjusting the series resistors, but this method is not in general recommended, except for special cases. These resistance values are chosen to give the best accuracy under varying temperature or polyphase unbalancing conditions. Where it is desired to entirely change the rating or full scale capacity of an instrument, special directions should be obtained from the Company, or the entire instrument should be returned to the factory for this purpose.

Shunted type D-C. ammeters are calibrated as millivoltmeters with the rated millivolts (generally 100 MV full scale) applied to the outer ends of the special leads furnished with the instrument. When calibrating these for use with shunts below 200 Amp. capacity allow for the shunted current taken by the instrument, which is approximately $\frac{1}{2}$ ampere. For example, for a 100 ampere shunt $100 \text{ M.V.} = (100 - .5) = 99.5 \text{ amp.}$

Polyphase wattmeters are calibrated on single phase circuits, with the current coils in series and the potential coils in parallel. When used with transformers the "Calibration Constant" is equal to the product of the CT and the PT ratios.

TYPE G-40 RECORDING INSTRUMENTS—Continued

Varmeters (volt-ampere-reactive) are ordinary wattmeters with an external "reactive compensator" or phase shifting transformer unit, for measuring the sine component of the voltamperes. The calibration is the same as that of the straight wattmeter. In some cases the zero is placed in the center of the scale instead of at the left end, to show power flow reversal or reactive power reversal.

Portable shunted D-C.-A-C. wattmeters are specially calibrated for both D-C. and A-C. operation, by adjusting the full scale current to be 5 amperes at nominal (i.e. for instance 500) watts D-C. and adjusting the resistance of the current coil and shunt leads to take 5 amperes when 100 millivolts are applied.

Accuracy Rating—The accuracy ratings are expressed in terms of full scale capacity per A.S.A. standards and are as follows.

Permanent magnet moving coil types:

D-C. shunt operated (100 M.V.)
ammeters..... Within 1½%

D-C. voltmeters and milliam-
meters..... Within 1%

Single element Electrodynamic types:

A-C. Voltmeters and ammeters
..... Within 1%.

A-C. wattmeters and varmeters
..... Within 1%.

Power Factor meters*..... 1%

Frequency meters*..... 1%

Double element Electrodynamic types:

A-C. Polyphase wattmeters and
varmeters..... Within 1%.

Power Factor meters*..... 1%

Frequency meters*..... 1%

*Variations of ¼ cycle clearly shown.

Variation in Records

Sluggishness of action, indicated by the record not showing actual variations in the quantity measured, may be due to one of the following causes: (a) friction in the movable system of the meter element; (b) friction in the pen operating mechanism.

Friction in the moving element can be best detected by removing the pen and tilting the chart unit forward. Move the damping disk slightly from side to side and note whether it returns to the original position. Friction in the moving element may be due to dirt, or magnetic particles in the air gaps, or to a damaged jewel or pivot.

If the friction only exists when the pen is in action with the ink flowing correctly, the friction obviously is due to

roughness or other incorrect condition of the pen or paper, or to the balance weight causing the pen to bear too heavily on the paper.

The character of the record obtained depends on the speed of the chart paper and the nature of the circuit. The choice of a chart speed depends upon the character of the load and the accuracy with which it is desired to read the time. On loads which are subject to large swings and oscillations, it is usually best to use a speed of six inches an hour, otherwise the ink will soak through the paper causing the pen to wear through it and no record will be obtained as the pen traverses the same line several times and wears through the paper. On a higher speed, the paper will move slightly between successive trips and the record will be legible.

Excessive shocks or vibration may also cause records to be unsatisfactory, by producing an excessive flow of ink, or causing the pen to wear through the paper.

PRINCIPLES OF OPERATION

The G-40 recorders are of the "direct acting" type, in which the recording mechanism, is driven directly by the measuring elements. The movements are magnetically shielded against external fields. In general the measuring elements operate on the same principle as corresponding indicating instruments. However, in order to operate through the friction of the marking pen, the elements are made much larger and powerful than those of indicating instruments, and they take correspondingly a larger amount of power to operate the coils. Briefly the characteristics of the different G-40 forms are as follows.

GX-40

Permanent Magnet Moving Coil Principle—Self-contained ammeters and milliammeters require only that the proper polarity be supplied, and that the current is within the full-scale rating of the instrument.

Self-contained ammeters and milliammeters for D-C.

Millivoltmeters and shunt operated ammeters for D-C.

Voltmeters for D-C.

Type GX-40 ammeters, using external shunts, read full scale for 100 millivolts, for zero left scale. If, as noted in paragraph 4, the instrument is adjusted for center zero, the reading will be 50—0—50 millivolts. When used as a zero left instrument, a regular 100-millivolt shunt is used at its rated capacity to supply a full-scale reading on the recorder. For center zero, a 100-millivolt shunt would supply 50 millivolts for half its current rating, since this is all that is required for a center zero type GX-40. The millivolt rating refers to the drop across the outer ends of the shunt leads, and not to the instrument terminal voltage.

Voltmeters—These are applicable to cases where it is necessary to use a polarized type of voltmeter. The sensitivity is approximately 40 ohms per volt.

GY-40**Electrodynamic Principle**

For A-C. power frequency circuits or for D-C. self-contained ammeters, up to 20 Amp. max.

Ammeters for use with current transformers.

Voltmeters for direct connection or for use with potential transformers. The voltmeters are suitable for A-C. power frequency applications and also with slightly less accuracy for D-C. circuits.

Wattmeters, single element, 2 element and 3 current coil forms. These electrodynamic instruments have iron cored magnetic circuits in order to increase the operating torques. In this respect they differ from the ordinary indicating type electrodynamic instruments. Damping is by means of a watt-hour meter form of disk with watt-hour meter damping magnets of the usual type, as shown in Fig. 5.

The polyphase wattmeters are made in two forms as follows: (See also diagrams of connections).

The two element wattmeters are for application to 2 or 3 phase 3 wire systems, or to single phase 2 or 3 wire systems.

The three current coil wattmeters are for application to 3 phase 4 wire systems which may be unbalanced.

The straight 2 element wattmeter can be used on balanced 3 phase 4 wire systems.

TYPE G-40 RECORDING INSTRUMENTS—Continued

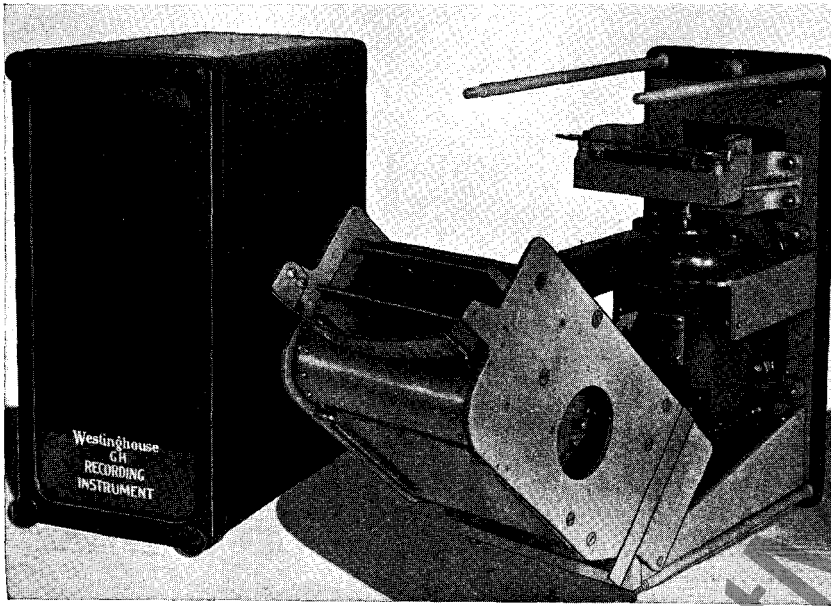

FIG. 6—TYPE GH RECORDING INSTRUMENT OPERATED BY ADS POSITION MOTOR

The power factor meters and resonant circuit frequency meters also have movements operating on the electrodynamic principle.

A-C-D-C. Electrodynamic watt-meters, of the portable type are applicable for use on direct currents in connection with ammeter shunts, and at the same time for use on A-C., from the secondaries of current transformers. See special notes given in connection with the diagrams, Figures 73 to 77.

GS-40

Position Recorder—This instrument is largely used at the receiving end of a position type telemeter system.

The usual duplicate units of synchrotie motors are required, one on the recorder, and the other at the point the position of which is to be recorded. The motor used in the recorder rotates 300 degrees, and is geared down to the scale angle of 48 degrees, insuring increased accuracy of readings.

It is essential to connect the leads in the proper sequence corresponding to the sequence of the leads in the transmitting instrument.

Corresponding leads on the transmitter and recording receiver are marked for identification to agree with the connections used in the original calibration.

A precaution to be observed is to avoid open circuiting any of the connections while the pen is in position, because the

very high torque action of the instrument is sufficient to seriously damage pen if the armature turns too suddenly. For the same reason the movement must be locked in position and only released after the current is applied.

The Connection diagrams are furnished with the Westinghouse instruction leaflet pertaining to the position type telemeter system and transmitter.

GH-40 PILOTEL RECORDER

The Pilotel is adapted to the measurement and recording of quantities, the low power of which precludes the direct action of the pen element.

The friction of a pen across paper, even although small, is much too large to permit direct recording of currents of micro-magnitude. Using the principle of magnetic pickup and electronic amplifier, a high-torque action is produced in the pilotel type recorder.

An amplifier is provided to drive the pen, and it is actuated by a driving motor, the position of which is determined by a pilot element, which in turn is guided by low-energy measuring device.

Since the great advantage of this type recorder lies in its ability to record low-energy quantities, it is regularly made with high sensitivity moving elements. With moving coil permanent magnet measuring elements, the energy consumption for full-scale recording can be as low as 5 microwatts.

The amplifier is a simple device operating on the "null" principle. No calibration is required, further insuring reliability. A spare set of tubes should be kept available so that replacement can readily be made by simply sub-

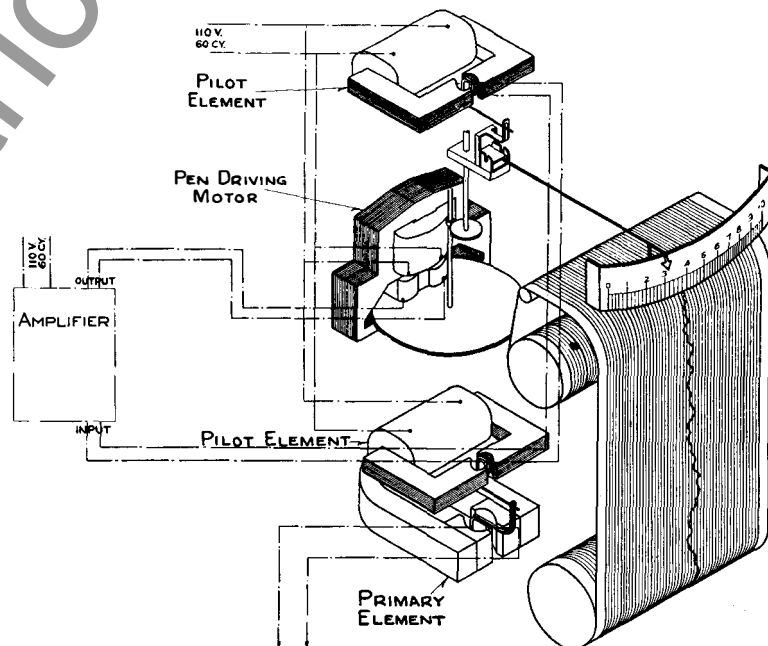

FIG. 7—SCHEMATIC DIAGRAM OF THE PILOTEL RECORDER

TYPE G-40 RECORDING INSTRUMENTS—Continued

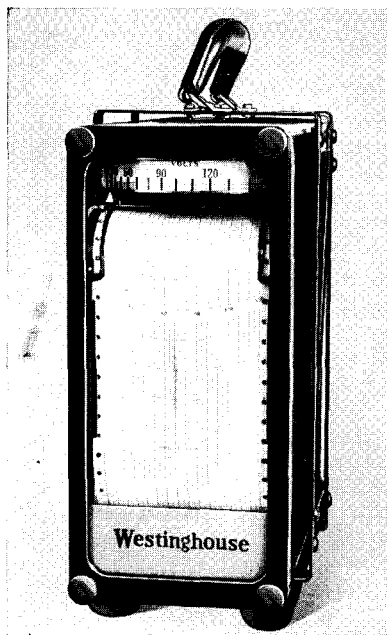

FIG. 8—PORTABLE TYPE GY-40 RECORDING A-C. VOLTMETER

stituting new ones for those that have been in service.

This electronic recorder consists essentially of the following parts:

- a. The primary or measuring element which may be any usual type indicating instrument mechanism.
- b. The pilot element attached to the measuring element.
- c. The pilot element at the pen mechanism.
- d. The motor element for driving the recording pen and for carrying the second pilot element coil.
- e. An amplifier for furnishing reversible driving power to the pen motor.

The principle of operation of the recorder may be understood by a study of the schematic diagram Fig. 7 and the following explanation:

The primary element, which may be any electrical measuring mechanism the position of which depends upon the quantity being measured, is mechanically connected to a pilot element which comprises a moving coil mechanism rotatable in an alternating current field. This field is provided by a stationary electromagnet connected to an auxiliary controlling circuit. The moving coil of

this pilot coil is connected in series with the moving coil of the duplicate pilot element which is mechanically connected to the pen-driving motor as shown in the schematic diagram. The stationary fields of both pilot elements are connected in parallel to the same a-c. source. The moving coils of the pilot elements are connected in series opposing each other. When these coils do not occupy the same relative positions in the a-c. fields, the voltage induced in the coils are not equal, so that the output voltage at the terminals of the pilot moving coils is of a value depending upon the magnitude of this difference. This voltage is of the order of 50 millivolts per degree deflection. The output of these coils is connected to the grid of the amplifier tube of the power amplifier unit. The a-c. output of the amplifier is the same frequency as the pilot element excitation.

The pen-driving motor is essentially a two-phase motor of which one phase is continually energized from the same source of power as the pilot element electromagnet coils. The phase position of the current in the other phase of the motor is determined by the relative positions of the pilot coils which determine the polarity and magnitude of voltage of the amplifier grid, and as a consequence, the a-c. output of the amplifier. With the second phase of the pen-driving motor connected to the amplifier output, the motor will turn in a clockwise or counter-clockwise direction at a speed proportional to the difference in pilot coil positions. This results in a proportionate response action of the pen motor.

The pen motor turns in one direction or the other until the difference in pilot voltages is zero, which results in a null method. As such, it is free from any errors which might result from aging, or change in characteristics of the vacuum tubes, which would result during their normal life. Usual decreases in emission or amplification factor result only in a decrease in the speed of response which is so small as to be unnoticeable for normal changes. Changes in control voltage within rather wide limits produce no noticeable effect. This is also true for changes in control frequency and wave form. Temperature changes produce no error. Stray fields affect both pilot coils equally so that no errors result.

Decreased output of tubes due to aging has the same effect as a decrease in control voltage; namely, a reduction in torque gradient. A large decrease in response is an indication that new tubes are required.

Flush Mounted Switchboard Type

The instructions for the projecting type recorders are equally applicable to the flush type except that the zero adjusting mechanism Fig. 5 is arranged for accessibility from the front after removal of the flush type glass cover.

Portable Recorders

The portable instruments consist of a switchboard type unit and a resistor compartment unit (for voltmeters or wattmeters only), mounted in a carrying frame as shown in Fig. 8. The instructions for the switchboard type are to be followed in general for the portable type. However on account of the nature of the service, special precautions must be taken when using portable instruments.

When removing a portable instrument from a test location, or transferring it to another location proceed as follows:

- (a) Disconnect all circuits.
- (b) Remove the pen unit and the inkwell so as to avoid spilling the ink in transit. Clean out the ink, or return it to the bottle for future use.
- (c) If the instrument will not be used quite soon, clean out the capillary pen.
- (d) Lock the movement for transportation, by means of the "movement lock nut" Fig. 5, (GY-40 type only) replace the pen in position. Stop the clock (if key wound).

The special portable wattmeters which are intended for both A-C. and D-C. service are specially calibrated to operate at both 100 millivolts, D-C. and at 5 amperes D-C. or A-C., full scale. See figures 73 to 77 and sub notes given with the figures. It is essential to use only the special leads furnished with the instrument when connecting to a D-C. shunt, and to have all the connections perfectly clean and tight.

TYPE G-40 RECORDING INSTRUMENTS—Continued

OUTLINE DIMENSIONS IN INCHES

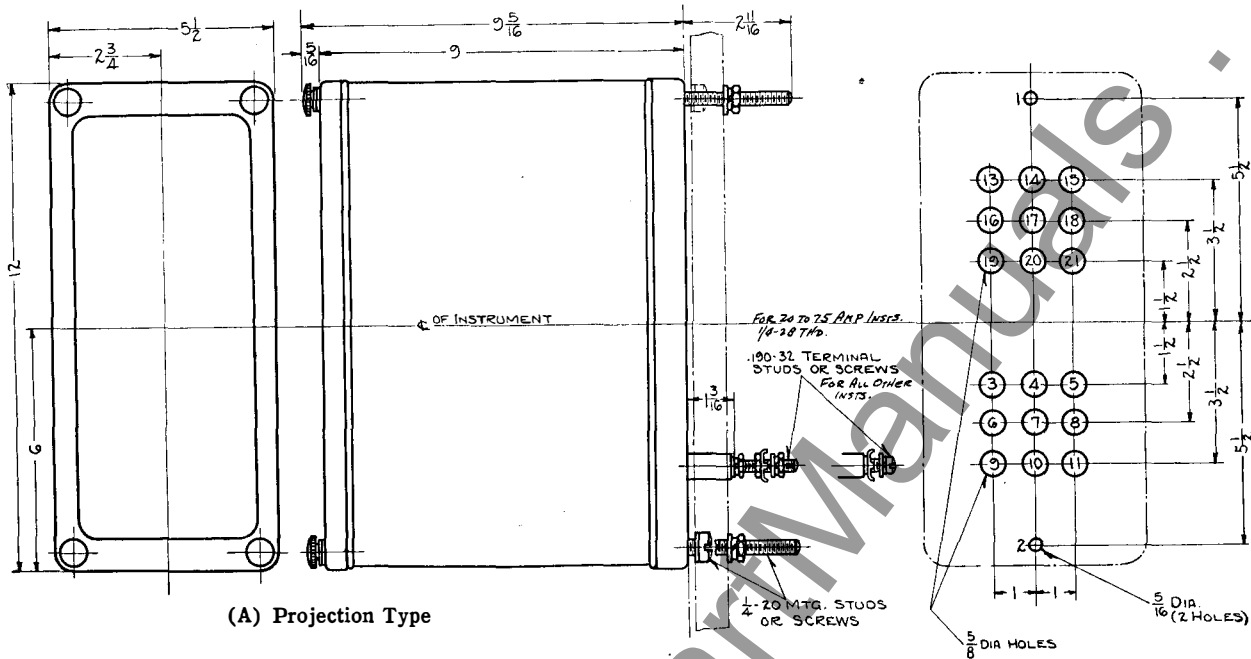

(A) Projection Type

DRILLING INSTRUCTIONS

Type of Instrument	Drill Hole No.
"GY" Polyphase Watt Meter.....	1-2-3-5-6-8-16-18-19-21
"GY" Polyphase Watt Meter—3 Current Coil.....	1-2-3-4-5-6-7-8-16-18-19-21
"GY" Single Phase Watt Meter.....	1-2-16-18-19-21
"GY" Voltmeter and Ammeter—"A-C".....	1-2-16-18
"GS" Differential Position Recorder.....	1-2-16-17-18-19-20-21
"GX" Voltmeter and Ammeter—"D-C".....	1-2-6-8
"GY" Single Phase Wattmeter—Double Current Range.....	1-2-3-5-6-8-16-18
"GY" Polyphase Wattmeter—Double Current Range.....	1-2-3-4-5-6-7-8-16-17-18-19-20-21
"GS" Position Recorder.....	1-2-16-17-18-19-21
Syn. Clock (Single Voltage Rating).....	9-11
Syn. Clock (Two Voltage Rating).....	9-10-11

NOTE:—FOR 3/8 OR 1/2" METAL SWITCHBOARD, USE SCREWS FOR MOUNTING INSTRUMENT & TERMINALS.
 FOR 1/4" TO 1" SWITCHBOARD, USE STUDS FOR MOUNTING INSTRUMENT & SCREWS FOR TERMINALS.
 FOR ALL OTHER SWITCHBOARDS, USE STUDS FOR MOUNTING INSTRUMENTS & FOR TERMINALS

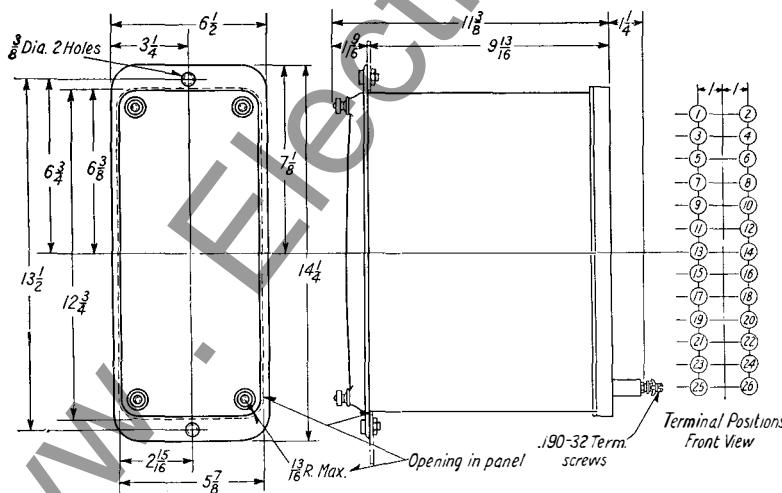

(B) Flush Type

FIG. 9—OUTLINE AND DRILLING PLAN, TYPE G-40 RECORDERS

Type of Instrument	TERMINAL NUMBERS USED For Inst. Mechanism
Ammeter	15-16
Voltmeter	15-16
1 Ph. Wattmeter	15 to 18 incl.
P. Ph. Wattmeter	15 to 22 incl.
3 Curr. Coil Wattmeter	11-12, 15 to 22 incl.
2 Ph. 4 W. Wattmeter	15 to 22 incl.
2 Ph. 4 W. Varmeter	15 to 22 incl.
3 Ph. 3 W. Varmeter	15 to 22 incl.
P. Ph. Power Factor Meter	17 to 22 incl.
Frequency Meter	15-16-19
Position Recorder	17 to 21 incl.
Diff. Pos. Recorder	17 to 22 incl.
For Syn. Motor Clock When Used	25-26
For Lamps When Used	5-6

General Data

SUPPLIES FURNISHED WITH EACH RECORDER

Quantity	Style	Description
3	Chart rolls, 3 inches per hour (supplied for low range when recorder has more than one range, unless otherwise specified on order).
1	059 478	Red ink, 2 oz. bottle, ready to use.
1	72 449	Rubber syringe for filling ink well.
1	837 390	Rubber syringe for starting pen.
1 pkg.	837 391	Pen cleaning wires.
1	876 241	Winding key (furnished with recorders having handwound clocks).
1*	820 502	Change gear for 3/4" per hour.
1*	820 488	Change gear for 1 1/4" per hour.
1**	820 486	Change gear for 3" per hour.
1*	820 484	Change gear for 6" per hour.

Change gears are conveniently mounted in the chart mechanism and may be changed at will. Only one gear need be changed.

ADDITIONAL SUPPLIES

Description	Style No.	Description	Style No.
Red ink (2 oz. bottle, ready to use).....	1 059 478	Green Ink (2 oz. bottle ready to use).....	1 209 421
Red ink (8 oz. bottle, ready to use).....	1 059 479	Green Ink (8 oz. bottle ready to use).....	1 209 422
Red ink (16 oz. bottle, ready to use).....	1 059 480	Green Ink (16 oz. bottle ready to use).....	1 209 423
Pen complete with balancing nut.....	837 392	Thumb nut to hold change gears.....	820 479
Ink well complete.....	1 003 925	Chart rewind spring belt (15 3/8" long).....	836 127
Pen starting syringe.....	837 390	Chart rewind spool.....	836 073
Ink well filling syringe.....	72 449		
Pen cleaning wires (style includes 1 doz.).....	837 391	Bearings for (dynamometer) alternating current recorders.	
		Jewel screw.....	876 914
		Jewel screw lock nut.....	876 889
		Pivot.....	876 903
Synchronous motor driven clock 115 volt, 60 cycle.....	1 158 339		
Synchronous motor driven clock 115 volt, 50 cycle.....		
Synchronous motor driven clock 115 volt, 25 cycle.....	Bearings for (permanent magnet moving coil) direct current recorders.	
Handwound 8-day clock.....	876 242	Jewel screw.....	877 013
Winding key for handwound clock.....	876 241	Jewel screw lock nut .190-32 Hex. B.M. Sc. Nut Pin.	
Carrying case 6 1/2" x 19" x 17" high, covered with Fabricoid, to contain complete meter, extra charts, supplies, etc.....	1 096 004	2-C.....	Std. Hdwr.
		Pivot.....	876 370

POWER CONSUMPTION

Direct Current Recorders

Type	At Rating	Circuit	Watts	Ohms Resistance
GX-40 Millivoltmeter, 0-100 M.V.	100 M.V.	Millivolt	.05	0.2
GX-40 Ammeter, 0-5 A.	5	Current	0.5	.02
GX-40 Voltmeter, 0-150 V.	150	Voltage	3.75	6000

Alternating Current Recorders

Type	At Rating	Circuit	60 CYCLE			
			V.A.	Watts	Vars	% P.F.
GY-40 Ammeter, 0-5 A.....	5	Current	10	6.25	7.8	62.5
GY-40 Voltmeter, 0-150 V.....	115	Voltage	13.3	13.3	0.0	100
GY-40 Single Phase Wattmeter.....	5	Current	7.05	2.8	6.4	40
		Voltage	115	12.5	0.0	100
GY-40 3 Ph. 3-W. Wattmeter, 2 Ph. 4-W. Wattmeter.....	5	Current	6.0	3.3	5.0	55
		Voltage	115	12.9	0.0	100
GY-40 3 Ph. 4-W.	5	Current { A	3.0	1.7	2.5	55
		{ C	3.0	1.7	2.5	55
		{ B	6.0	3.3	5.0	55
Wattmeter (3 C.C.—2 P.C.).....	115	Voltage	12.9	12.9	0.0	100
†GY-40 3 Ph. 3-W.	5	Current	6.0	3.3	5.0	55
†Varmeter (2 C.C.—2 P.C.).....	115	Voltage { A-B	7.45	-5.7	...
		{ B-C	7.45	+1.7	...
		{ C-A	13.9	-2.0	...
Frequency Meter.....	115	Voltage	6.4	6.4	0.4	99
Power Factor Meter.....	115	Voltage	13.	13.	0	100
	5	Current	18.6	9.5	16.	51
	5	Current	12.	6.4	10.1	55

† Varmeter voltage circuit burdens include burdens of compensators.

Synchronous Clock Motors

GY-40 Syn. Motor }.....	115	Voltage	3.3
Driven Clock }.....	230	Voltage	6.

Internal Connection Diagrams—Front View

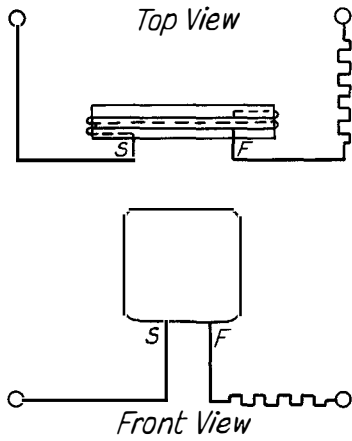

FIG. 10—TYPE GX-40 D-C. RECORDING VOLTMETERS OR MILLIVOLTMETER WITH SERIES RESISTANCE

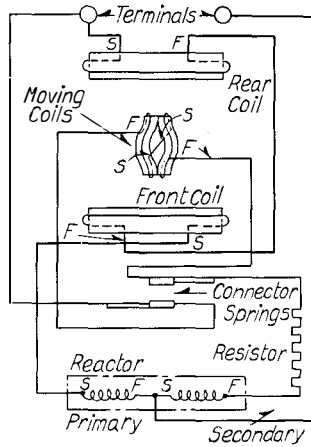

FIG. 11—TYPE GY-40 ELECTRODYNAMIC AMMETER 2.5, 5, 7.5 AND 10 AMP. (COILS IN SERIES)

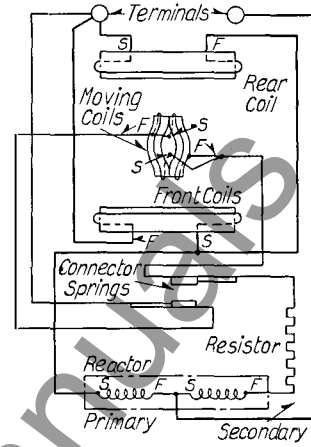

FIG. 12—TYPE GY-40 ELECTRODYNAMIC AMMETER 15 AND 20 AMP. (COILS IN PARALLEL)

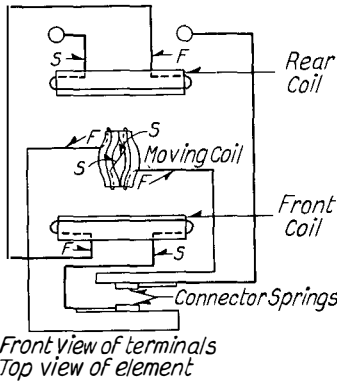

FIG. 13—TYPE GY-40 ELECTRODYNAMIC VOLT-METER

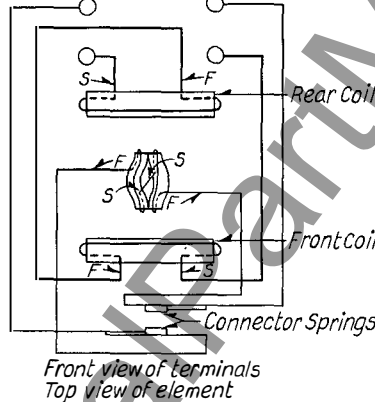

FIG. 14—TYPE GY-40 SINGLE-PHASE WATTMETER

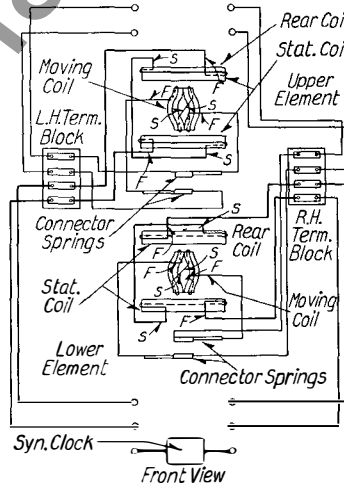

FIG. 15*—TYPE GY-40 POLYPHASE WATTMETER

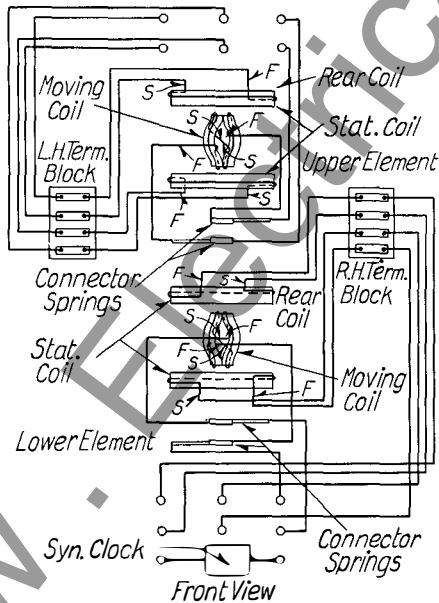

FIG. 16*—TYPE GY-40 POLYPHASE WATTMETER WITH TWO CURRENT RANGES

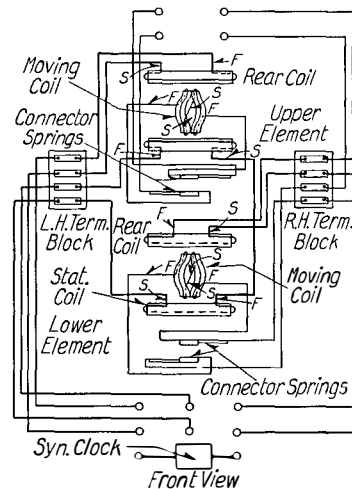

FIG. 17*—TYPE GY-40 THREE CURRENT COIL POLYPHASE WATTMETER

S—Signifies START Lead F—Signifies FINISH Lead

*These diagrams show coils connected to stud pairs arranged vertically as in projection type instruments. The internal coil connections of the flush type instruments terminate on studs arranged horizontally as shown in external diagrams, Figures 51 to 57 inc.

External Connection Diagrams

INSTRUMENTS SHOWN REAR VIEW. EXTERNAL BOXES SHOWN FRONT VIEW.

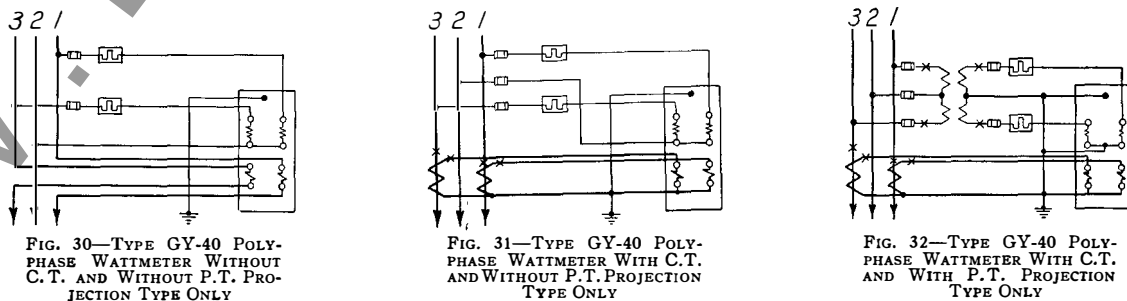
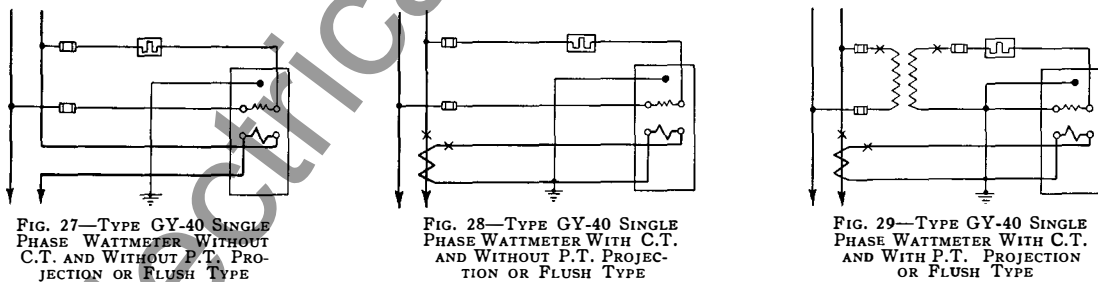
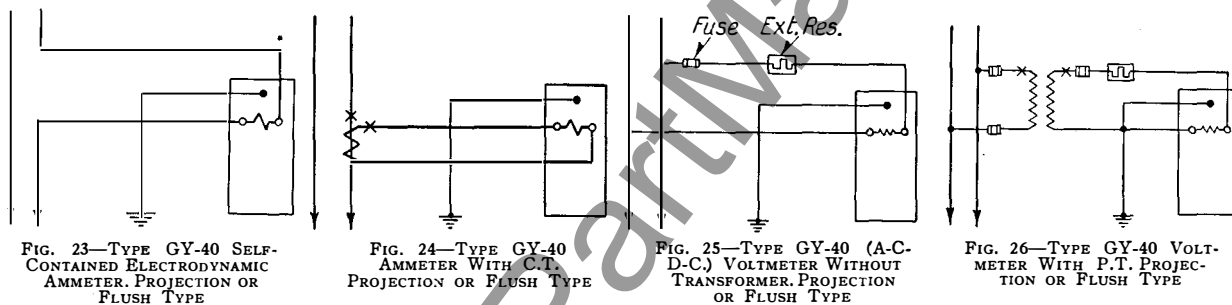
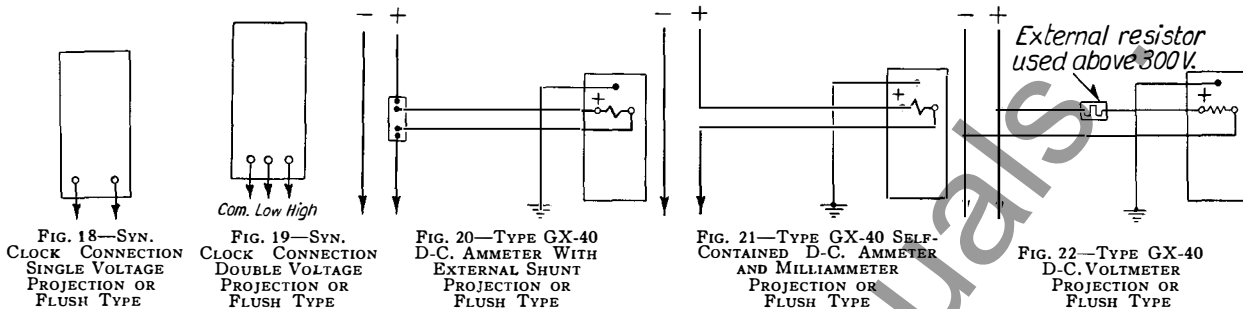

External Connection Diagrams—Continued

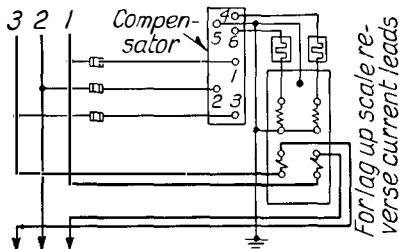

FIG. 33—TYPE GY-40 3 PHASE—3 WIRE VARMETER WITHOUT C.T. AND WITHOUT P.T. PROJECTION TYPE ONLY

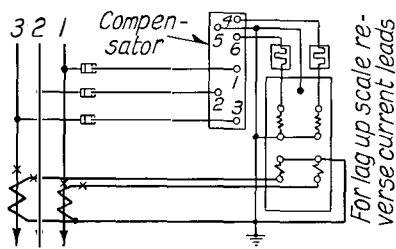

FIG. 34—TYPE GY-40 3 PHASE—3 WIRE VARMETER WITH C.T. AND WITHOUT P.T. PROJECTION TYPE ONLY

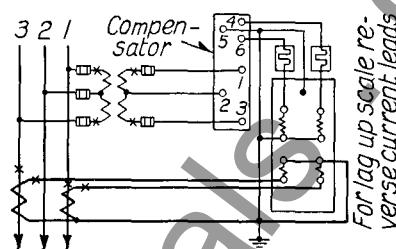

FIG. 35—TYPE GY-40 3 PHASE—3 WIRE VARMETER WITH C.T. AND WITH P.T. PROJECTION TYPE ONLY

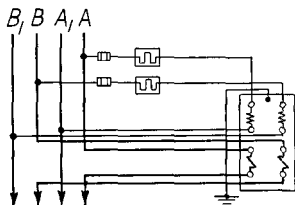

FIG. 36—TYPE GY-40 2 PHASE—4 WIRE POLYPHASE WATTMETER WITHOUT C.T. AND WITHOUT P.T. PROJECTION TYPE ONLY

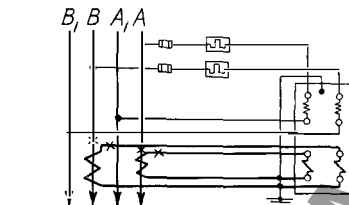

FIG. 37—TYPE GY-40 2 PHASE—4 WIRE POLYPHASE WATTMETER WITH C.T. AND WITHOUT P.T. PROJECTION TYPE ONLY

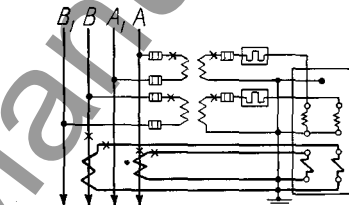

FIG. 38—TYPE GY-40 2 PHASE—4 WIRE POLYPHASE WATTMETER WITH C.T. AND WITH P.T. PROJECTION TYPE ONLY

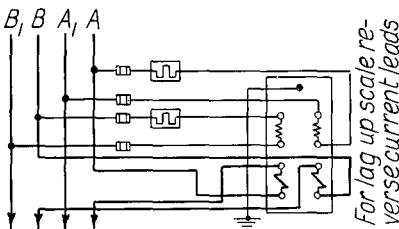

FIG. 39—TYPE GY-40 2 PHASE—4 WIRE POLYPHASE VARMETER WITHOUT C.T. AND WITHOUT P.T. PROJECTION TYPE ONLY

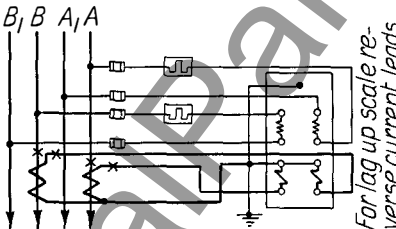

FIG. 40—TYPE GY-40 2 PHASE—4 WIRE POLYPHASE VARMETER WITH C.T. AND WITHOUT P.T. PROJECTION TYPE ONLY

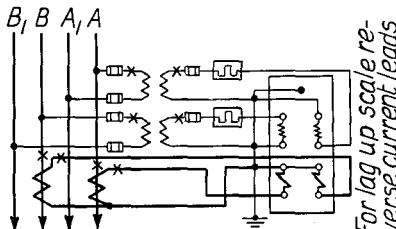

FIG. 41—TYPE GY-40 2 PHASE—4 WIRE POLYPHASE VARMETER WITH C.T. AND WITH P.T. PROJECTION TYPE ONLY

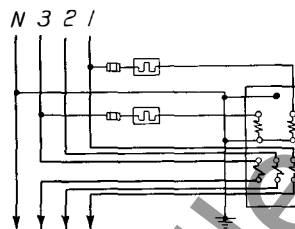

FIG. 42—TYPE GY-40 3 C.C. POLYPHASE WATTMETER WITHOUT C.T. AND WITHOUT P.T. PROJECTION TYPE ONLY

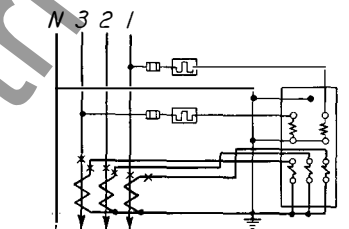

FIG. 43—TYPE GY-40 3 C.C. POLYPHASE WATTMETER WITH C.T. AND WITHOUT P.T. PROJECTION TYPE ONLY

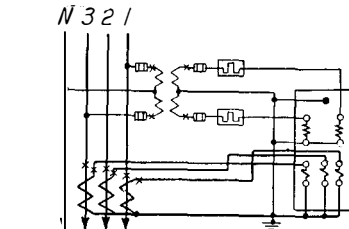

FIG. 44—TYPE GY-40 3 C.C. POLYPHASE WATTMETER WITH C.T. AND WITH P.T. PROJECTION TYPE ONLY

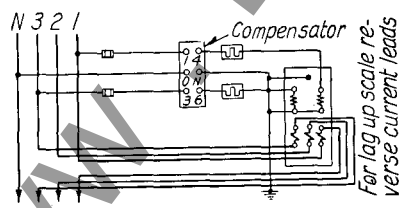

FIG. 45—TYPE GY-40 3 C.C. 3 PHASE—4 WIRE VARMETER WITHOUT C.T. AND WITHOUT P.T. PROJECTION TYPE ONLY

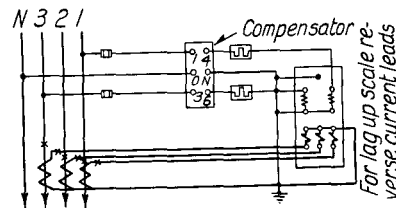

FIG. 46—TYPE GY-40 3 C.C. 3 PHASE—4 WIRE VARMETER WITH C.T. AND WITHOUT P.T. PROJECTION TYPE ONLY

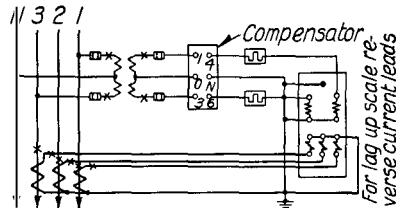

FIG. 47—TYPE GY-40 3 C.C. 3 PHASE—4 WIRE VARMETER WITH C.T. AND WITH P.T. PROJECTION TYPE ONLY

External Connection Diagrams—Continued

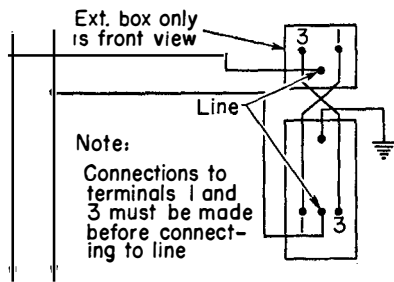

FIG. 48—TYPE GY-40 FREQUENCY METER, PROJECTION TYPE

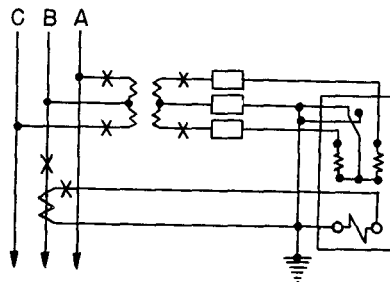

FIG. 49—TYPE GY-40 POLYPHASE POWER FACTOR METER WITH ONE CURRENT TRANSFORMER, PROJECTION TYPE

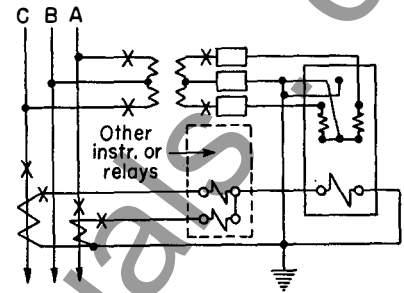

FIG. 50—TYPE GY-40 POLYPHASE POWER FACTOR METER WITH TWO CURRENT TRANSFORMERS, PROJECTION TYPE

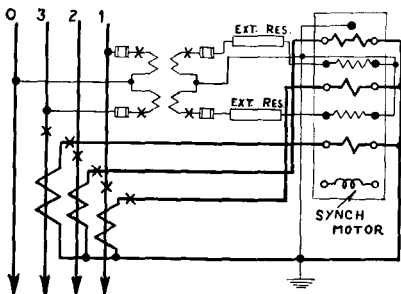

FIG. 51—THREE CURRENT COIL WATTMETER, FLUSH TYPE ONLY

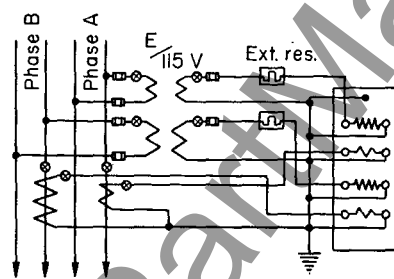

FIG. 52—TWO-PHASE, 4-WIRE WATTMETER, FLUSH TYPE ONLY

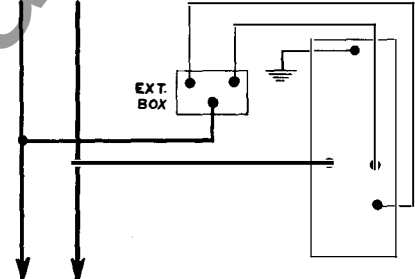

FIG. 53—FREQUENCY METER, FLUSH TYPE ONLY

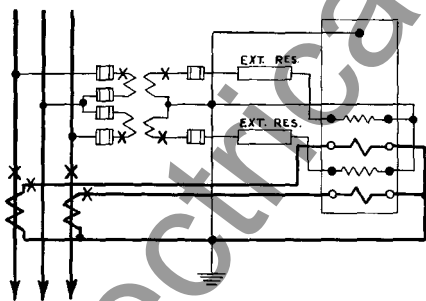
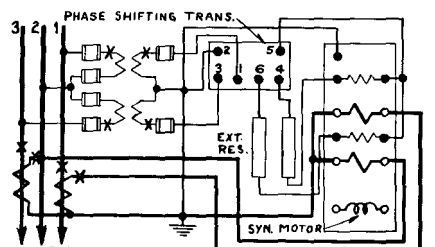

FIG. 54—POLYPHASE WATTMETER, FLUSH TYPE ONLY



2 ELEMENT METER 2PH-3W
CORRECT PH. SEQUENCE 1-2-3
CONNECTIONS ARE FOR LAG-0-LEAD SCALE REVERSE CUR. COIL CONN
FOR LEAD-0-LAG. STD. WATTMETER CALIBRATION.

FIG. 55—THREE-PHASE, 3-WIRE VAR METER, FLUSH TYPE ONLY

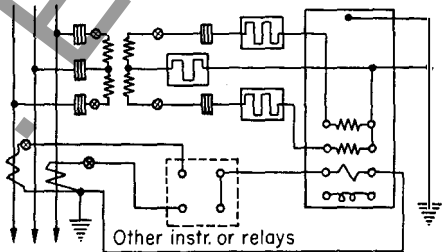

FIG. 56—POLYPHASE POWER FACTOR METER WITH TWO CURRENT TRANSFORMERS, FLUSH TYPE ONLY

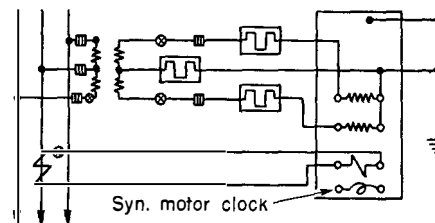
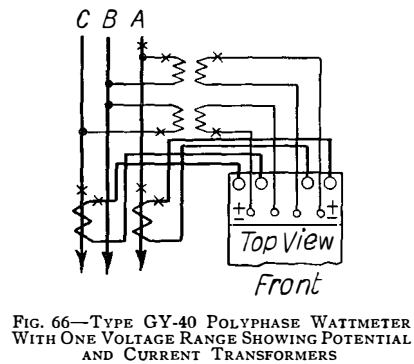
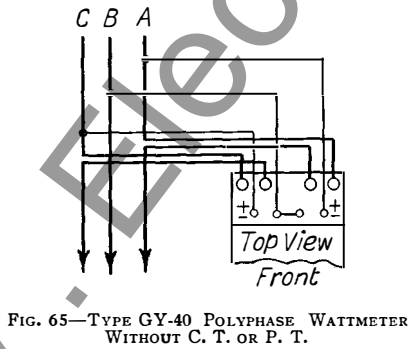
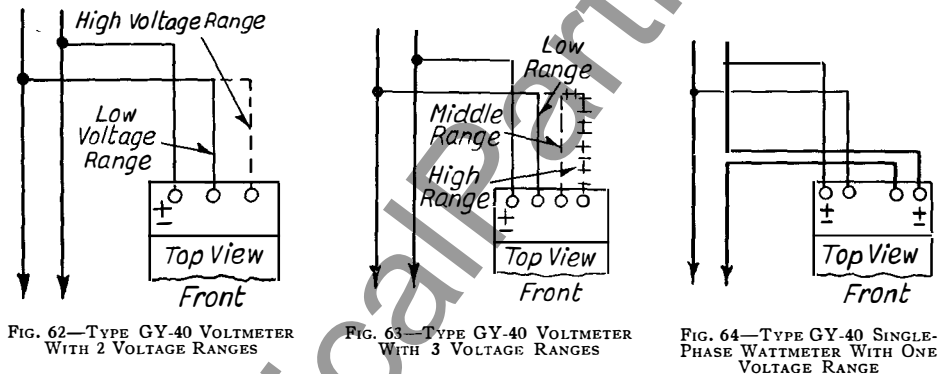
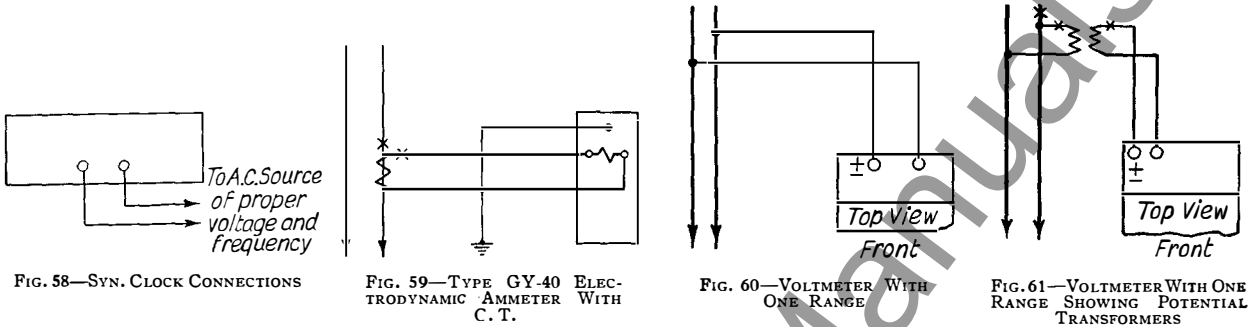

FIG. 57—POLYPHASE POWER FACTOR METER WITH ONE CURRENT TRANSFORMER, FLUSH TYPE ONLY

PORTABLE RECORDING INSTRUMENTS

External Connection Diagrams

For connections for GX-40 Portable D.C. Ammeters and Voltmeters refer to switchboard connection diagrams, Figures 18 to 22.



PORTABLE RECORDING INSTRUMENTS—Continued

EXTERNAL CONNECTION DIAGRAMS—Continued

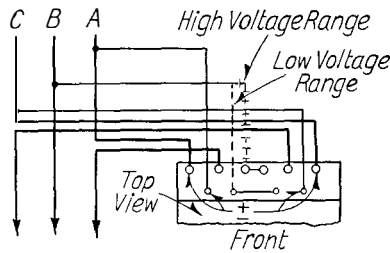

FIG. 67—TYPE GY-40 POLYPHASE WATTMETER WITH 2 VOLTAGE RANGES

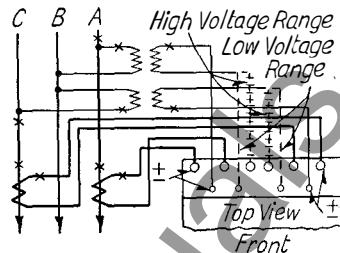

FIG. 68—TYPE GY-40 POLYPHASE WATTMETER WITH 2 VOLTAGE RANGES SHOWING POTENTIAL AND CURRENT TRANSFORMERS

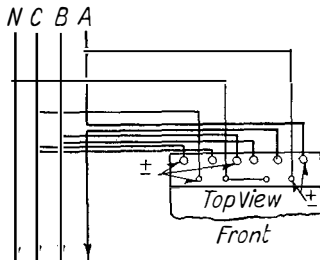

FIG. 69—TYPE GY-40, 3 CURRENT COIL POLYPHASE WATTMETER WITHOUT C.T. OR P.T.

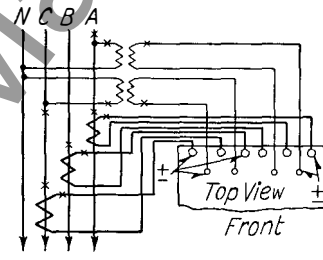

FIG. 70—TYPE GY-40, 3 CURRENT COIL POLYPHASE WATTMETER WITH P.T. AND C.T.

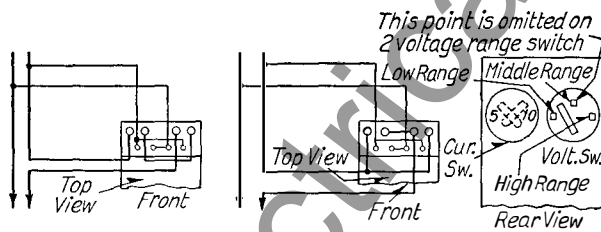

FIG. 71—EXTERNAL CONNECTIONS FOR POLYPHASE WATTMETER HAVING RANGE CHANGING SWITCHES FOR 2 CURRENT RANGES AND 2 OR 3 VOLTAGE RANGES WHEN USED IN A SINGLE-PHASE CIRCUIT

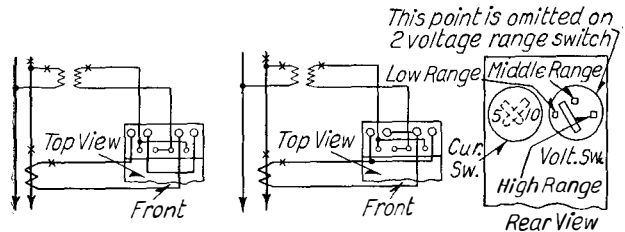

FIG. 72—EXTERNAL CONNECTIONS SHOWING CURRENT AND POTENTIAL TRANSFORMERS FOR POLYPHASE WATTMETER HAVING RANGE CHANGING SWITCHES FOR 2 CURRENT RANGES AND 2 OR 3 VOLTAGE RANGES WHEN USED IN A SINGLE-PHASE CIRCUIT

Multipliers for Fig. 71—Left View Only.
For right View Multiplier is 1/2 Values Given.

CURRENT	0-1000 WATT SCALE		MULTIPLIER*
	CURRENT	VOLTAGE	
5 Amp.	100	1/2	
5 Amp.	200	1	
10 Amp.	100	1	
10 Amp.	200	2	
5 Amp.	500	2 1/2	
10 Amp.	500	5	

Multipliers for Polyphase Wattmeter having range-changing switches when used on 3 phase, 3 wire, per Fig. 65-66.

CURRENT	0-1000 WATT SCALE		MULTIPLIER*
	CURRENT	VOLTAGE	
5 Amp.	100	1	
5 Amp.	200	2	
10 Amp.	100	2	
10 Amp.	200	4	
5 Amp.	500	5	
10 Amp.	500	10	

Where current or voltage transformers/or both are used also multiply by the product of the transformer ratios.

EXTERNAL CONNECTION DIAGRAMS—Continued

PORTABLE D-C.-A-C. WATTMETERS

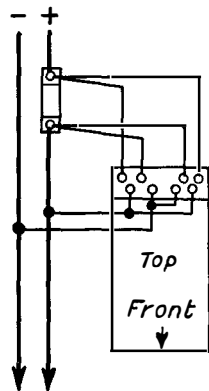

FIG. 73—TWO-WIRE D-C.

With this connection the coils divert 10 amperes from the shunt. Shunts up to 2000 amperes are adjusted to allow for this.

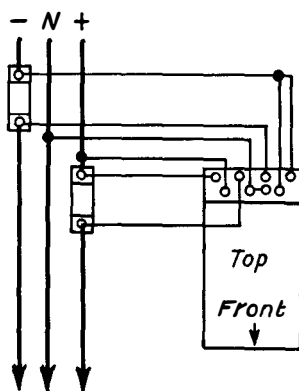

FIG. 74—THREE-WIRE D-C.

With this connection the coils divert 5 amperes from each shunt. Shunts up to 1000 amperes are adjusted to allow for this.

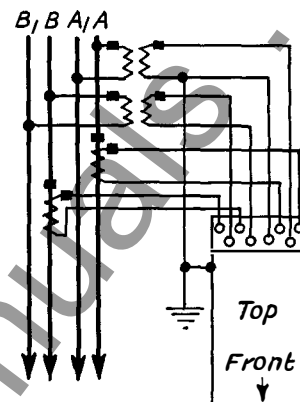

FIG. 75—TWO-PHASE, FOUR-WIRE

With these connections Figs. 73, and 74 it is specially important to use only the shunt leads furnished, and to have all the connections clean and tight.

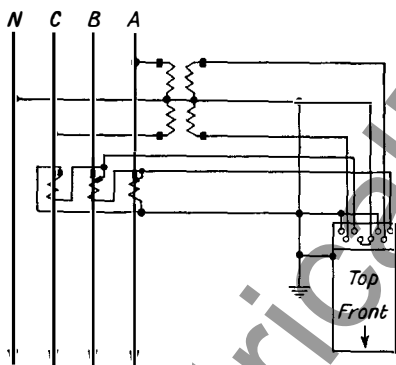

FIG. 76—THREE-PHASE, 4-WIRE WITH CURRENT AND POTENTIAL TRANSFORMER.

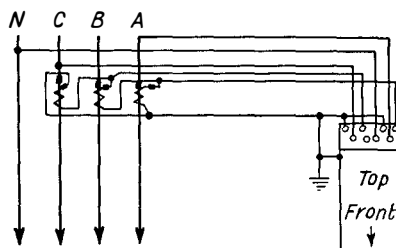

FIG. 77—THREE-PHASE, 4-WIRE WITH CURRENT TRANSFORMER.

NOTE: For one, two, or three phase, wire follow Figures 65 and 66.

RETURN TO
Westinghouse Electric Corp.
METER DIVISION
NEWARK, N. J.

Westinghouse Electric Corporation
Meter Division, Newark, N. J.