

**Instructions for Installation,
Operation, and Maintenance of
Type VCP-W Vacuum
Circuit Breakers**

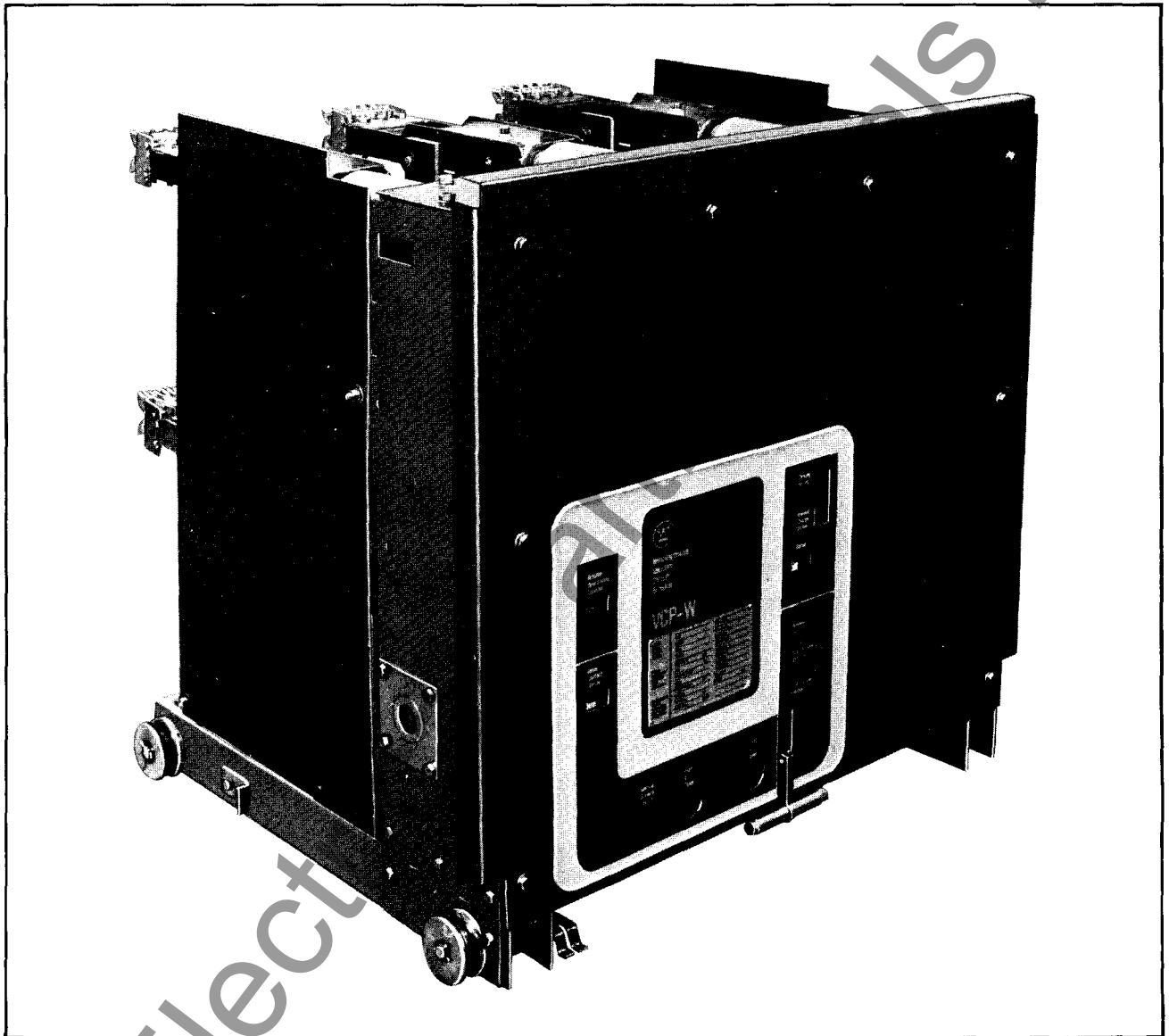

I.B. 32-255-1A



READ AND UNDERSTAND THESE INSTRUCTIONS BEFORE ATTEMPTING ANY UNPACKING, ASSEMBLY, OPERATION OR MAINTENANCE OF THE CIRCUIT BREAKERS.

All possible contingencies which may arise during installation, operation, or maintenance, and all details and variations of this equipment do not purport to be covered by these instructions. If further information is desired by purchaser regarding his particular installation, operation or maintenance of his equipment, the local Westinghouse Electric Corporation representative should be contacted.

Westinghouse Electric Corporation

Distribution and Control Business Unit
Electrical Components Division
Pittsburgh, PA 15220

Effective November, 1989 Supersedes I.B. 32-255-1 dated January, 1988

CAUTION

THE CIRCUIT BREAKERS DESCRIBED IN THIS BOOK ARE DESIGNED AND TESTED TO OPERATE WITHIN THEIR NAMEPLATE RATINGS. OPERATION OUTSIDE OF THESE RATINGS MAY CAUSE THE EQUIPMENT TO FAIL, RESULTING IN BODILY INJURY AND PROPERTY DAMAGE.

ALL SAFETY CODES, SAFETY STANDARDS AND/OR REGULATIONS AS THEY MAY BE APPLIED TO THIS TYPE OF EQUIPMENT MUST BE STRICTLY ADHERED TO.

TABLE OF CONTENTS

Description	Page	Description	Page
1.0 INTRODUCTION	3	5.4.4 Floor Tripping and Spring Release Interlocks	31
2.0 RECOMMENDED SAFE PRACTICES	5	5.5 Miscellaneous	33
3.0 RECEIVING, HANDLING, AND STORAGE	6	5.5.1 Ground Contact	33
3.1 Receiving	6	5.5.2 MOC and TOC Switch Operators	33
3.2 Handling	9	5.5.3 Operations Counter	33
3.3 Storage	9	5.6 Levering Device	33
4.0 INSTALLATION	11	6.0 MAINTENANCE	34
4.1 Initial Inspection and Operation	11	6.1 General	34
4.2 Manual Breaker Operation	11	6.2 Frequency of Inspection	34
4.3 Vacuum Interrupter Integrity Check	11	6.3 Inspection and Maintenance Chart	35
4.4 Primary and Secondary Insulation Check	11	6.4 Vacuum Interrupter Integrity Test	36
4.5 Contact Erosion Check	11	6.5 Contact Erosion and Wipe	37
4.6 Primary Circuit Resistance Check	11	6.6 Insulation	39
4.7 Nameplate Information Check	11	6.7 Insulation Integrity Check	39
4.8 Electrical Operation Check	11	6.8 Primary Circuit Resistance Check	39
4.9 Breaker/Compartment Interface Check	17	6.9 Mechanism Check	39
5.0 DESCRIPTION AND OPERATION	20	6.10 Lubrication	40
5.1 Interrupter Assembly	20	6.11 Troubleshooting Chart	40
5.1.1 Vacuum Interrupter	20	7.0 RENEWAL PARTS	43
5.1.2 Contact Erosion Indication	20	7.1 Recommended Parts	43
5.1.3 Contact Wipe and Stroke	21	7.2 Ordering Instructions	47
5.1.4 Phase Barriers	21	7.3 Replacement Procedures	48
5.2 Stored Energy Mechanism	24	7.3.1 Location of Components	48
5.2.1 Operation of Stored Energy Mechanism	24	7.3.2 Replacement of Vacuum Interrupter Assembly	49
5.2.2 Charging	24	7.3.3 Replacement of Push Rod Assembly	51
5.2.3 Closing Operation	24	7.3.4 Replacement of Spring Charging Motor	52
5.2.4 Tripping Operation	27	7.3.5 Replacement of Auxiliary Switch Assembly	53
5.2.5 Trip Free Operation	27	7.3.6 Replacement of Latch Check and Position Switches	54
5.3 Control Scheme	27	7.3.7 Replacement of Spring Release Coil and Shunt Trip Coil	55
5.3.1 Timing	30	7.3.8 Replacement of the Motor Cut Off Switch	56
5.3.2 Secondary Disconnects	30	APPENDIX	57
5.3.3 Undervoltage Trip Device	30		
5.4 Interlocks	31		
5.4.1 Breaker - Compartment Code Plates	31		
5.4.2 Positive Interlock	31		
5.4.3 Anti-Close Interlock	31		

SECTION 1 – INTRODUCTION

The purpose of this book is to provide instructions for unpacking, storage, installation, operation and maintenance of Type VCP-W, Vacuum Circuit Breakers. They are horizontal drawout type removable interrupting elements for use in VC-W Metal-Clad Switchgear to provide reliable control and protection for medium voltage electrical equipment and circuits. VCP-W breakers are designed for reliable performance with ease of handling and maintenance. Like ratings are interchangeable with each other.

Satisfactory performance of these breakers is contingent upon proper application, correct installation and adequate maintenance. It is strongly recommended this instruction book be carefully read and followed in order to obtain optimum performance for long useful life of the circuit breakers.

TYPE VCP-W BREAKERS ARE PROTECTIVE DEVICES, AS SUCH, THEY ARE MAXIMUM RATED DEVICES. THEREFORE, THEY SHOULD NOT UNDER ANY CIRCUMSTANCES BE APPLIED OUTSIDE THEIR NAMEPLATE RATINGS.

1.1 The available VCP-W breakers and their weights are listed in the table below:

Type of Breaker	Continuous Current Rating		Type of Breaker	Continuous Current Rating	
	Amps	lbs.		Amps	lbs.
50VCP-W250	1200	350	150VCP-W500	1200	350
	2000	410		2000	410
	3000	525		3000	525
50VCP-W350	1200	460	150VCP-W750	1200	350
	2000	490		2000	410
	3000	525		3000	525
75VCP-W500	1200	375	150VCP-W1000	1200	460
	2000	410		2000	490
	3000	525		3000	525

All possible contingencies which may arise during installation, operation, or maintenance, and all details and variations of this equipment do not purport to be covered by these instructions. If further information is desired by purchaser regarding his particular installation, operation or maintenance of his equipment, the local Westinghouse Electric Corporation representative should be contacted.

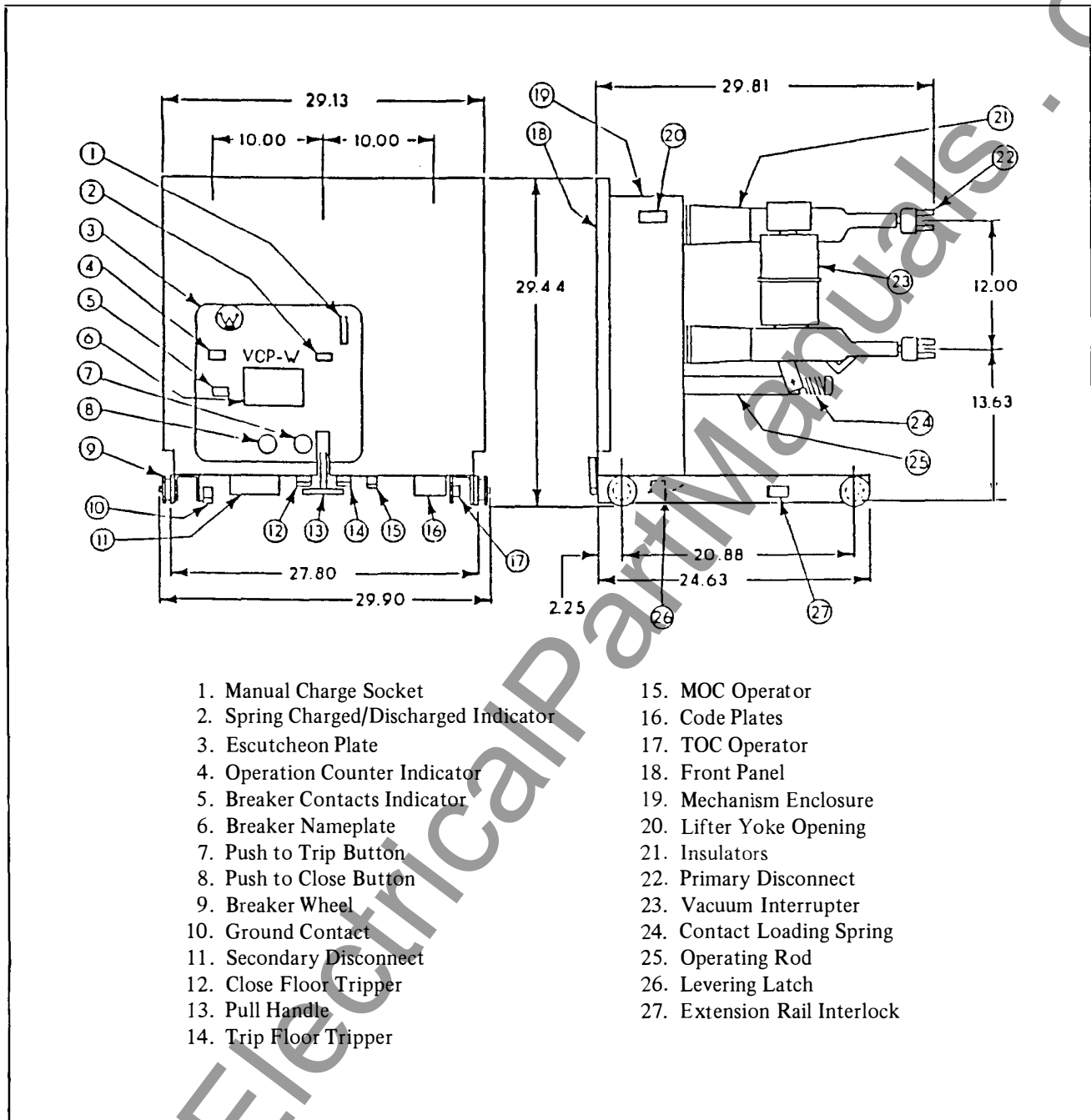

Fig. 1.1 Outline and Dimensions

SECTION 2 – SAFE PRACTICES

Type VCP-W breakers are equipped with high speed, high energy operating mechanisms. They are designed with several built-in interlocks and safety features to provide safe and proper operating sequences. To ensure safety of personnel associated with installation, operation and maintenance of these breakers, the following recommendations should be considered :

Only qualified persons, as defined in the National Electric Safety Code, who are familiar with the installation and maintenance of medium voltage circuits and equipment should be permitted to work on these breakers.

Read these instructions carefully before attempting any installation, operation or maintenance of these breakers.

- DO NOT work on an energized breaker.
- DO NOT work on a breaker with the secondary test coupler engaged.
- DO NOT work on a closed breaker or a breaker with closing springs charged.
- DO NOT USE a circuit breaker by itself as the sole means of isolating a high voltage circuit. For the safety of personnel performing maintenance operations on the breaker or connected equipment, all components should be disconnected by means of a visible break, and securely grounded.
- DO NOT leave breaker in an intermediate position in a cell. Always have the breaker either in the Test or Connected position.
- Always remove the maintenance tool from the breaker after charging the closing springs.
- Breakers are equipped with safety interlocks, DO NOT defeat them. This may result in bodily injury or equipment damage.

SECTION 3 – RECEIVING, HANDLING, AND STORING

Type VCP-W circuit breakers are subjected to complete factory production tests and inspection before being packed. They are shipped in packages designed to provide maximum protection to the equipment during shipment and storage and at the same time to provide convenient handling. Accessories such as the maintenance tool, levering crank, etc, are shipped separately with the switchgear assembly.

3.1 RECEIVING

Upon receipt of the equipment, inspect the crates for any signs of damage or rough handling. Open the crates carefully to avoid any damage to the contents. Use a nail puller rather than a crow bar.

When opening the crates, be careful that any loose items or hardware are not discarded with the packing material. Check the contents of each package against the packing list.

Examine the breaker for any signs of shipping damage such as broken, missing or loose hardware, damaged or deformed insulation and other components. File claims immediately with the carrier if damage or loss is detected and notify the nearest Westinghouse Sales Office.

Until the breaker is ready to be delivered to the switchgear site for installation, DO NOT remove it from the wooden crate. If the breaker is to be placed in storage, maximum protection can be obtained by keeping it in its crate.

TOOLS AND ACCESSORIES

Dockable Dolly: Used to insert or withdraw the breaker from the lower compartment without portable lifter. The dolly also may be used to transport the breaker around. (6510C71G01)

Maintenance Tool: Used to charge the closing springs manually and lift the shutter in breaker compartment. (8064A02G01)

Lifting Yoke: Used to lift the breaker. (691C607G01)

Levering Crank: Used to crank the breaker between Test and Connected positions. (Standard 701B601G02, with clutch 701B601G01).

Electric Levering Device: 1A30257G01

Test Jumper: Used to operate the breaker electrically as it rests on the extended rails outside the breaker compartment or on the transport dolly. This jumper connects the breaker secondary disconnects to the compartment secondary disconnects. (6526C23G01)

Test Cabinet: Used to provide power to operate the breaker outside its compartment. (8346A28G01 thru G04 depending upon control scheme and voltage requirement.)

Primary Disconnect Pliers: Used to install and remove primary disconnects. (591C901G01)

Portable Lifter: Used to lift the breaker from or to the extended rails of the breaker compartment. (6366C91H01)

Travel Transducer: Used to take time travel records. (701B613G01)

Ramp: Used to insert or withdraw the breaker from the lower compartment without portable lifter. (7811C71G01)

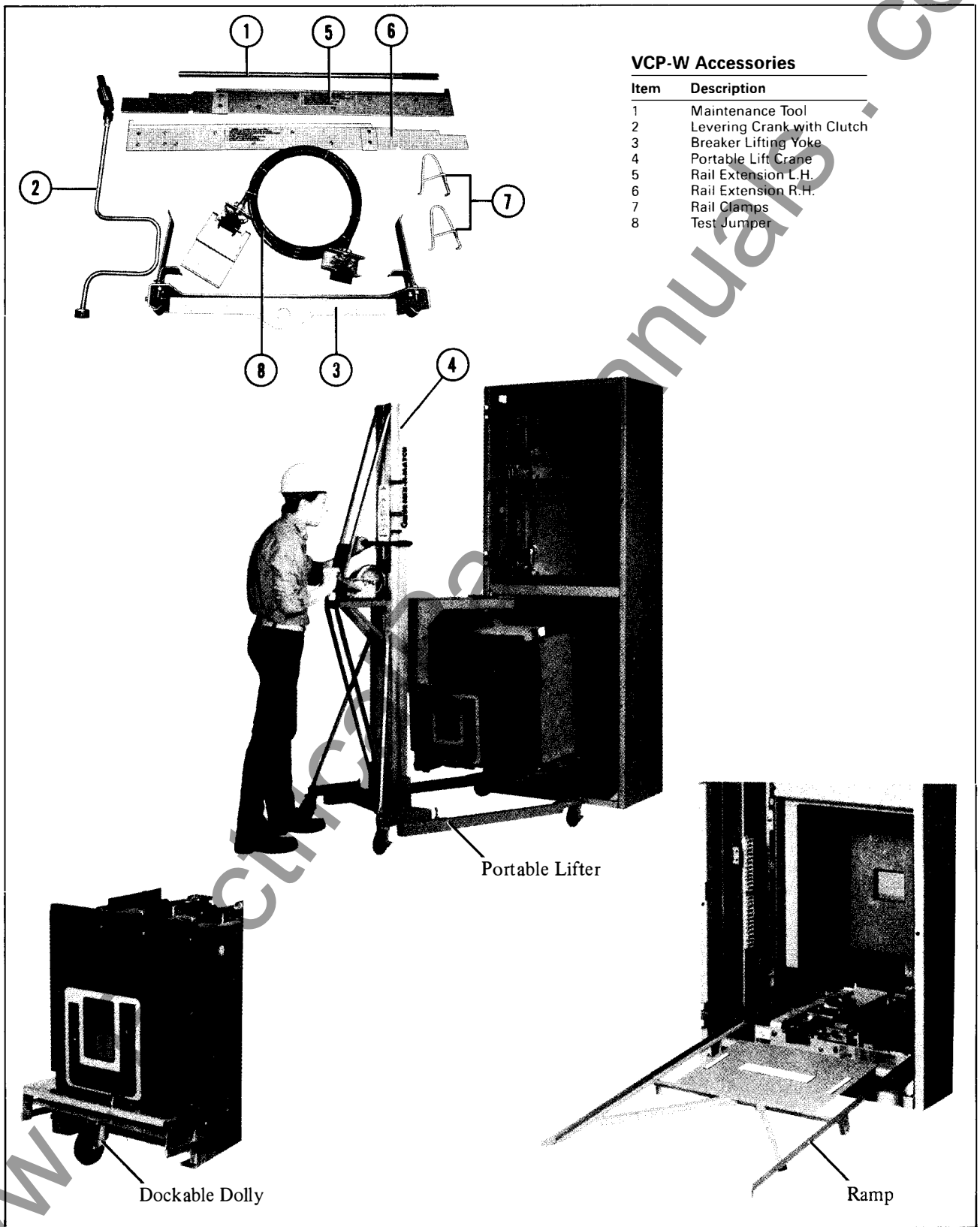

VCP-W Accessories

Item	Description
1	Maintenance Tool
2	Levering Crank with Clutch
3	Breaker Lifting Yoke
4	Portable Lift Crane
5	Rail Extension L.H.
6	Rail Extension R.H.
7	Rail Clamps
8	Test Jumper

Fig. 3.1 VacClad-W Switchgear Tools and Accessories

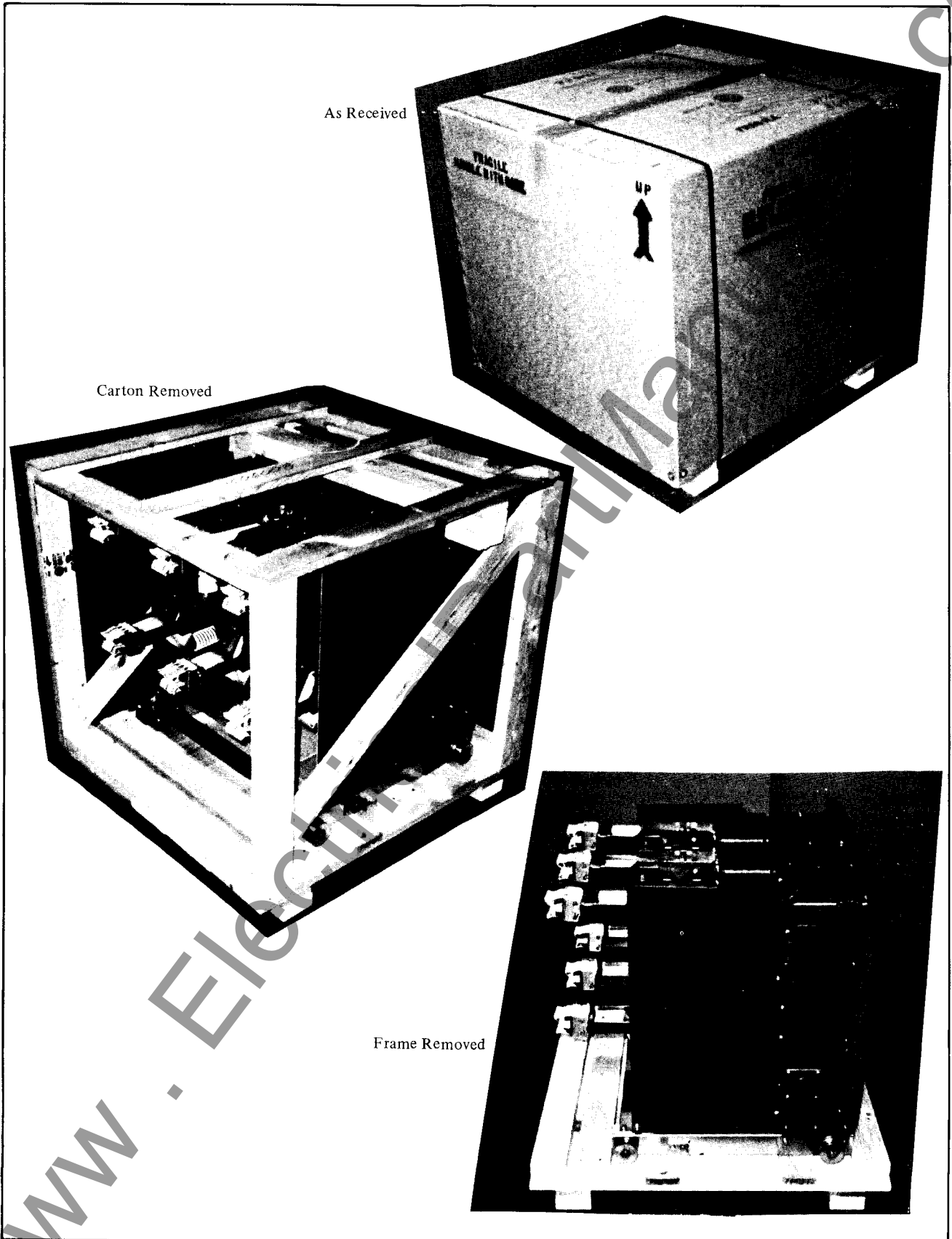

Fig. 3.2 Type VCP-W Breaker

3.2 HANDLING

Type VCP-W breaker shipping containers are designed to be handled either by use of a rope sling and an overhead lifting device or by fork lift truck. If containers must be skidded for any distance it is preferable to use roller conveyors or individual pipe rollers.

Once the breakers have been inspected for shipping damage, it is best to return them to their original shipping crates until they are ready to be installed in the Metal-Clad Switchgear.

The breaker is secured to the crate by banding straps. When it is ready for installation, remove these straps. A lifting yoke is provided for each order. Position this lifting yoke on the top of the breaker and insert lifters into the breaker side openings with the lifting hole towards the interrupters. It is recommended that the portable lifter (optionally provided) be used to lift the breaker. The crate should be raised on 2 x 4 or 4 x 4 blocks to permit the breaker lifting device legs to run underneath the crate. If the portable lifter is not available, any lifter may be used provided that it is rated for at least 800 lbs.

3.3 STORAGE

If the circuit breaker is to be placed in storage, maximum protection can be obtained by keeping it in the original wooden crate. Before placing it in storage, checks should be made to make sure that the breaker is free from shipping damage and is in satisfactory operating condition.

The breaker is shipped with its contacts open and closing springs discharged. The indicators on the front panel should confirm this. Insert the maintenance tool in the manual charge socket opening near center right. Charge the closing springs by pumping the handle up and down about 36 times until crisp metallic "click" is heard. This indicates that the closing springs are charged and is shown by the closing spring "charged" (yellow) indicator. Remove the maintenance tool. Push the "manual close" button. The breaker will close as shown by the breaker contacts "closed" (red) indicator. Push the "manual trip" button. The breaker will trip as shown by the breaker contacts "open" (green) indicator. After completing this initial check, leave the closing springs "discharged" and breaker contacts "open".

Outdoor storage is NOT recommended. If unavoidable, the outdoor location must be well drained and a temporary shelter from sun, rain, snow, corrosive fumes, dust, dirt, falling objects, excessive moisture, etc. must be provided. Containers should be arranged to permit free circulation of air on all sides and temporary heaters should be used to minimize condensation. Moisture can cause rusting of metal parts and deterioration of high voltage insulation. A heat level of approximately 400 watts for each 100 cubic feet of volume is recommended with the heaters distributed uniformly throughout the structure near the floor. If the circuit breakers are stacked for storage, the stacks should be limited to two high.

Indoor storage should be in a building with sufficient heat and circulation to prevent condensation. If the building is not heated, the same general rule for heat as for outdoor storage should be applied.

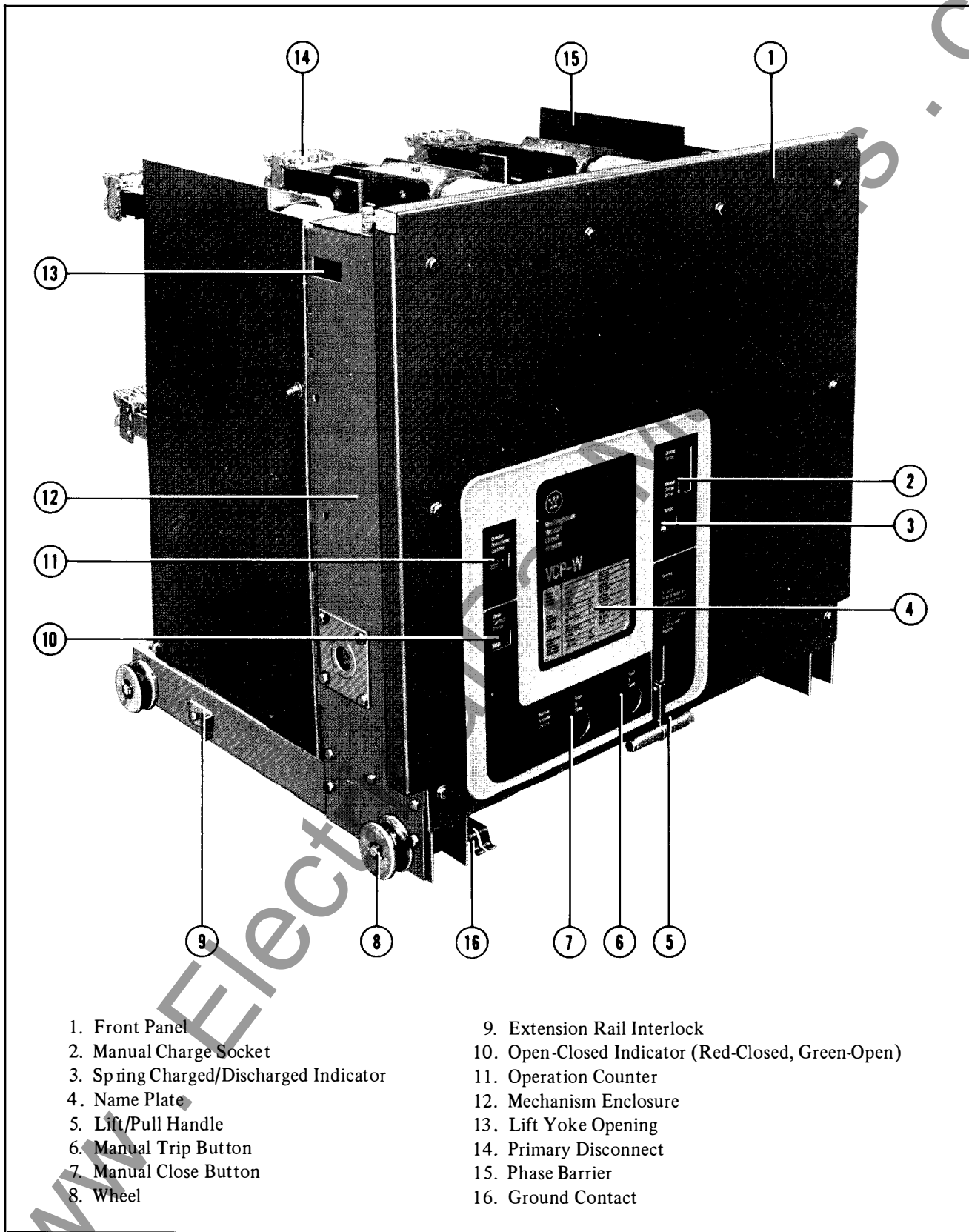

- | | |
|--|--|
| 1. Front Panel | 9. Extension Rail Interlock |
| 2. Manual Charge Socket | 10. Open-Closed Indicator (Red-Closed, Green-Open) |
| 3. Spring Charged/Discharged Indicator | 11. Operation Counter |
| 4. Name Plate | 12. Mechanism Enclosure |
| 5. Lift/Pull Handle | 13. Lift Yoke Opening |
| 6. Manual Trip Button | 14. Primary Disconnect |
| 7. Manual Close Button | 15. Phase Barrier |
| 8. Wheel | 16. Ground Contact |

Fig. 3.3 External View of the VCP-W Breaker

SECTION 4 - INSTALLATION

4.1 INITIAL INSPECTION AND OPERATION

Before attempting to put the breaker in service, it should be carefully examined and operated manually and electrically.

Examine breaker for loose or obviously damaged parts.

- 4.2 Perform Manual Operations Check: Place the maintenance tool into the manual charge socket opening and charge the closing springs with about 36 up and down strokes of the handle. When charging is complete, the closing crank goes over center with an audible “click” and the springs Charged/Discharged Indicator shows “Charged”.

Note: If the springs are to be charged on a closed breaker, no click is heard at the end of charging operation. Discontinue charging and remove maintenance tool as soon as "Charged" flag is fully visible. Continued attempt to further charge may result in the damage of mechanism.

Remove the maintenance tool.

Close and trip the breaker several times.

- 4.3 Check Vacuum Interrupter Integrity : Using a dry lint-free cloth or a paper towel, clean all the insulating surfaces of the pole units. Conduct a vacuum interrupter integrity check as described in the maintenance Section, 6.4.
- 4.4 Check breaker primary and secondary insulation per Section 6.6.
- 4.5 Check Contact Erosion Indicator : Manually charge the closing springs and close the breaker. View the vacuum interrupter moving stems from the rear of the breaker. The erosion mark should be visible on each vacuum interrupter moving stem as described in Section 6.5.
- 4.6 Check Primary Circuit Resistance : Check the primary circuit resistance as described in the Maintenance Section 6.8. The resistance should not exceed the values specified. Record the values obtained for future reference.
- 4.7 Compare the breaker nameplate information with switchgear drawings for compatibility. Breaker and compartment code plates do match power ratings, but do not match control voltages.
- 4.8 Perform electrical operations check.

After going through the above steps, the breaker is now ready to be operated electrically. It is preferred that this check be made with the breaker in the Test position in the breaker compartment.

CAUTION

WHILE CHECKS ARE PERFORMED IN THE BREAKER COMPARTMENT, CARE MUST BE EXERCISED TO MAKE CERTAIN THAT PRIMARY CIRCUIT IS NOT ENERGIZED.

- a. MAKE CERTAIN THAT LEVERING NUT IS ALL THE WAY UP FRONT INTO TEST POSITION. (See Figure 4.2, Item 6).
- b. Engage extension rails to the fixed rails. (See Fig. 4.4a).
- c. Load the breaker on extension rails carefully. (See Fig. 4.4b).

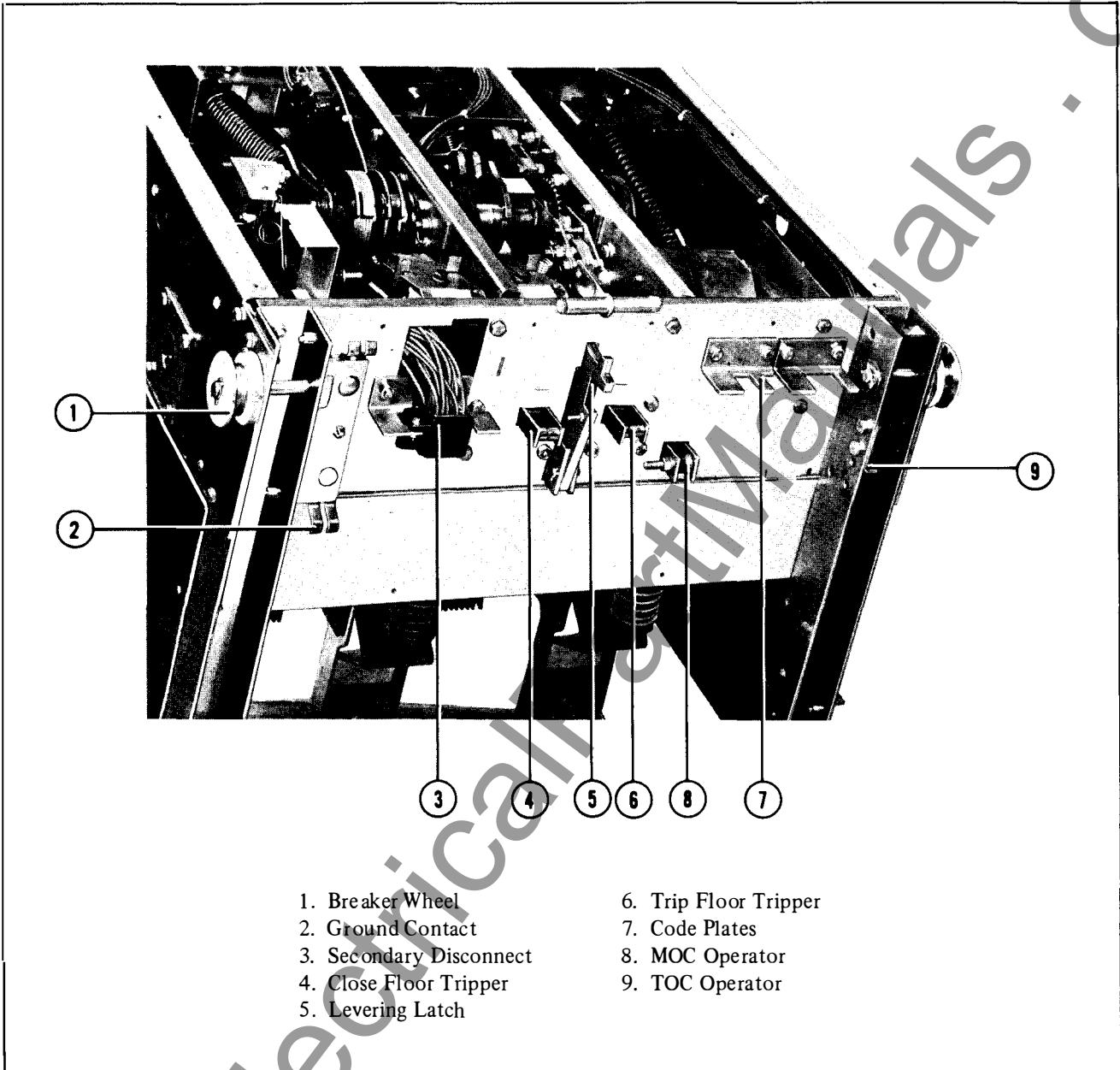
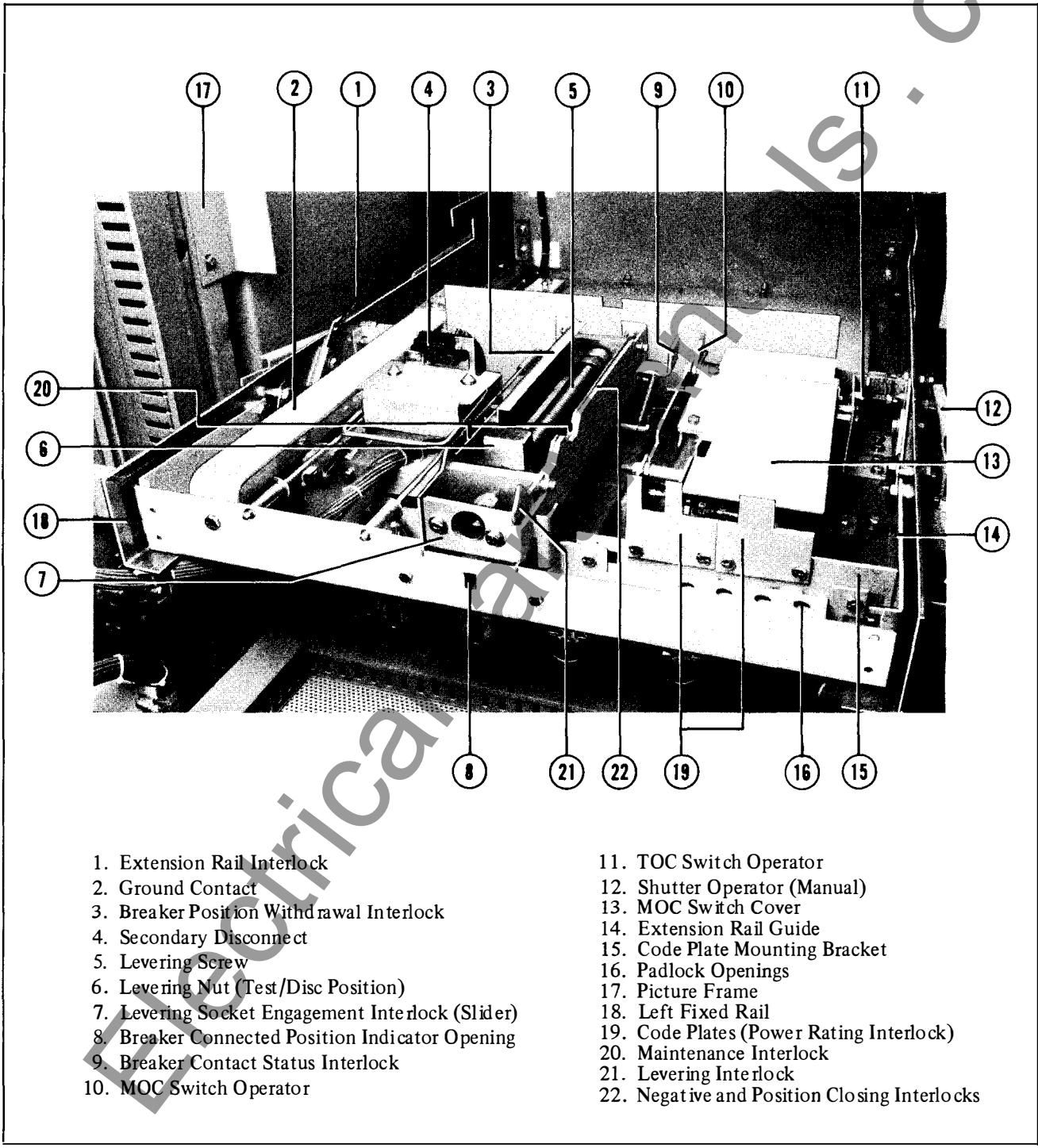
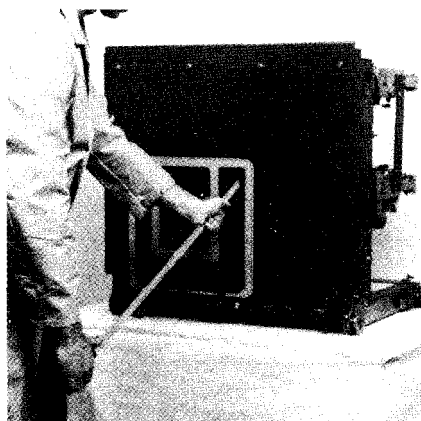

Fig. 4.1 VCP-W Breaker Showing Interface Components



- | | |
|---|--|
| <ul style="list-style-type: none"> 1. Extension Rail Interlock 2. Ground Contact 3. Breaker Position Withdrawal Interlock 4. Secondary Disconnect 5. Levering Screw 6. Levering Nut (Test/Disc Position) 7. Levering Socket Engagement Interlock (Slider) 8. Breaker Connected Position Indicator Opening 9. Breaker Contact Status Interlock 10. MOC Switch Operator | <ul style="list-style-type: none"> 11. TOC Switch Operator 12. Shutter Operator (Manual) 13. MOC Switch Cover 14. Extension Rail Guide 15. Code Plate Mounting Bracket 16. Padlock Openings 17. Picture Frame 18. Left Fixed Rail 19. Code Plates (Power Rating Interlock) 20. Maintenance Interlock 21. Levering Interlock 22. Negative and Position Closing Interlocks |
|---|--|

Fig. 4.2 VC-W Switchgear Breaker Compartment



a. Inserting the Maintenance Tool Into the Manual Charging Socket

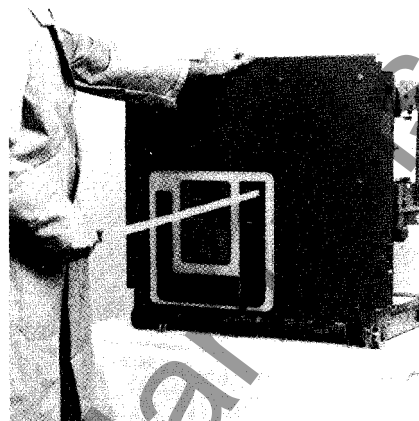

b. Charging the Closing Springs

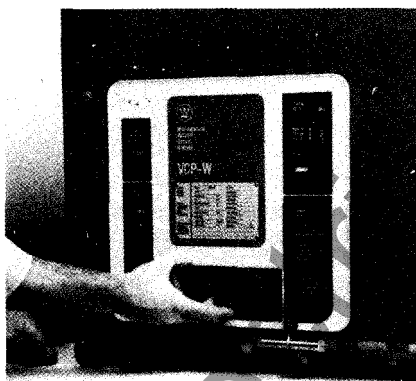

c. Manually Closing the Breaker

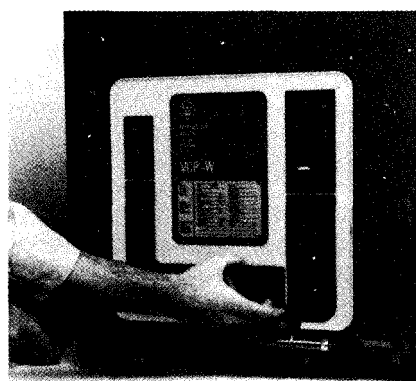

d. Manually Tripping the Breaker

Fig. 4.3 Type VCP-W Breaker Manual Operation Check

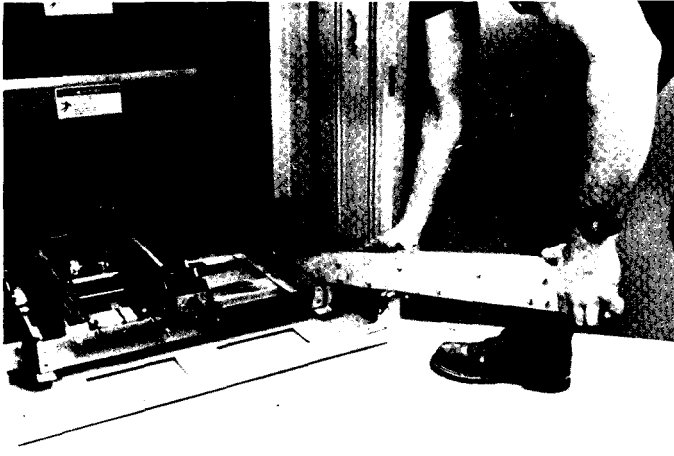

a. Inserting the Extension Rail in the Lower Compartment

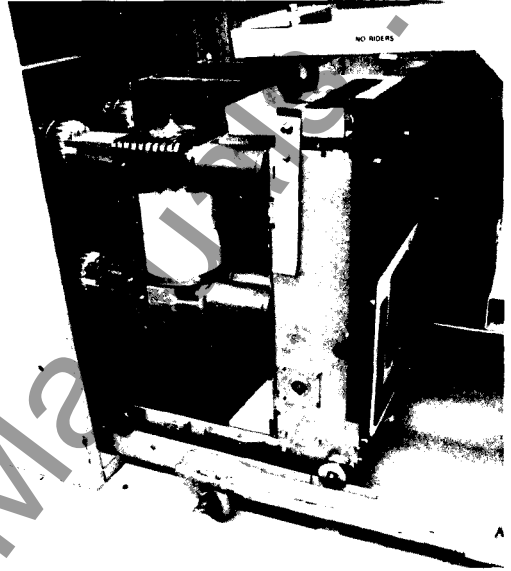

b. Lowering the Breaker on the Extension Rail



c. Removing the Lifting Yoke

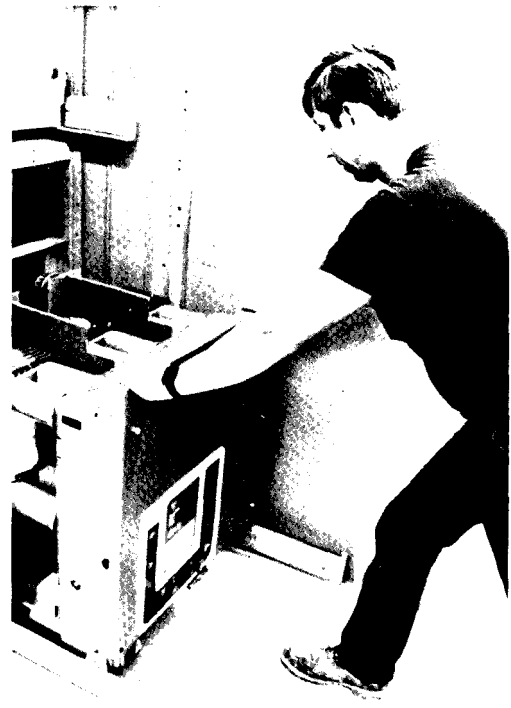

d. Pushing the Breaker to the Test Position

Fig. 4.4 Type VCP-W Breaker Installation Check

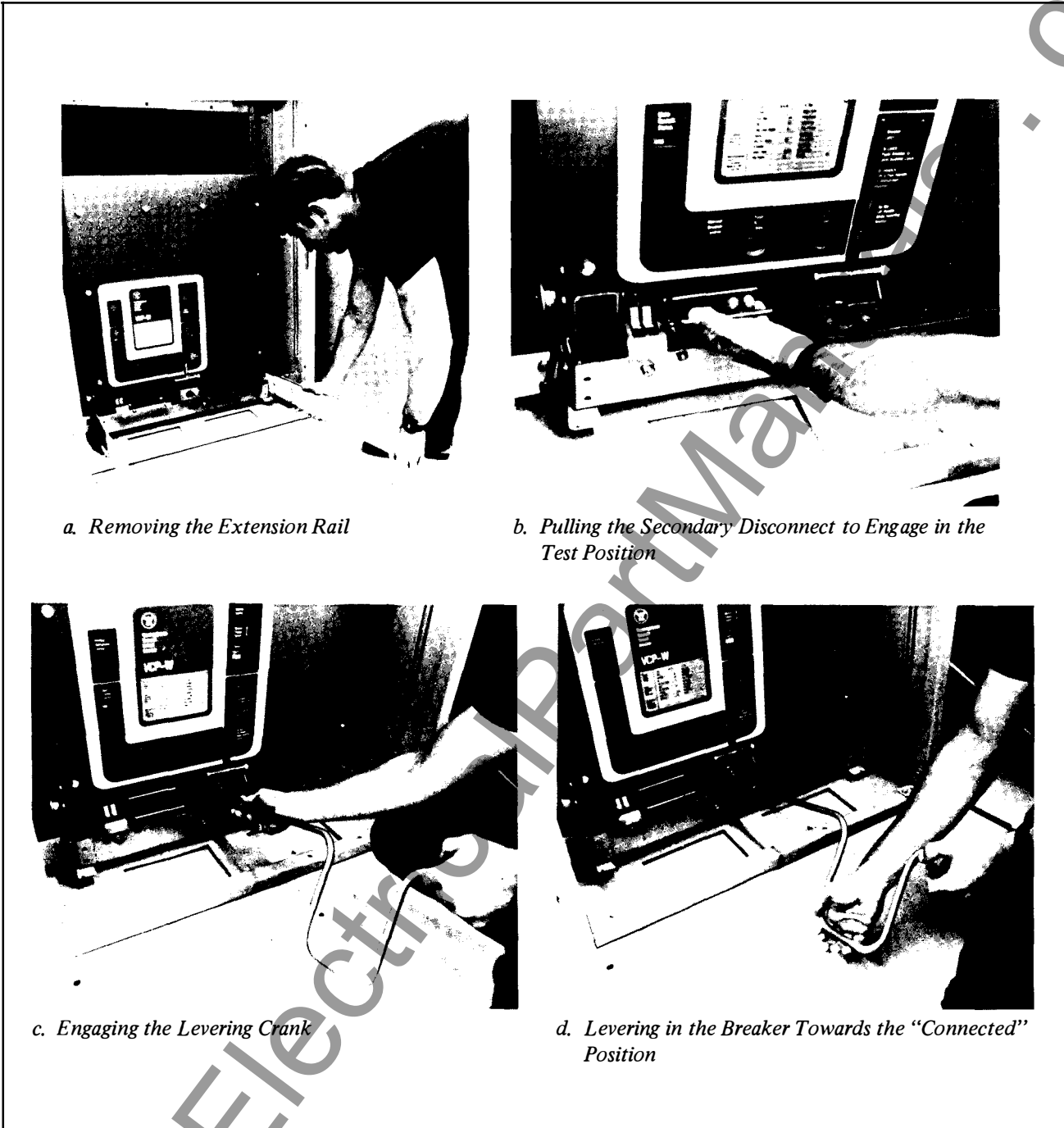

Fig. 4.5 Type VCP-W Breaker Installation Check

- d. Remove Auto Lifting Yoke. (See Fig. 4.4c)
- e. Push the breaker into the compartment (see Fig. 4.4d). Test position as confirmed by a crisp metallic sound of the breaker levering latch engaging the levering nut.
- f. Remove the extension rails. (See Fig. 4.5a)
- g. Raise the handle and pull secondary disconnect cage forward as far as possible to engage with breaker secondaries. As soon as control power is available, the motor will start charging the closing springs. (See Fig. 4.5b)
- h. Close and trip the breaker several times to verify closing and tripping operations.
- i. Close the breaker.

4.9 Breaker/Compartment Interface Check. The assembly is provided with the following interlocks to ensure safe and correct operation.

- (a) **POWER RATING INTERLOCK:**
Prevents the insertion of the breaker into the Test position unless enclosure power rating is equal or higher than breaker rating. (Fig. 4.2, Item 19.)
- (b) **MAINTENANCE INTERLOCK:**
Trips, closes and trips the breaker if it is closed and charged as it is moved from Test position to extension rails or from extension rails to Test position. (Fig. 4.2, Item 20.)
- (c) **LEVERING INTERLOCKS:**
Trips the breaker (if closed) as levering crank is engaged to move the breaker from Test to Connected position. (Fig. 4.2, Item 21.)
- (d) **POSITIVE INTERLOCK:**
Prevents engagement of the levering crank if the breaker is closed and in Connected position. (Fig. 4.2, Item 9.)
- (e) **NEGATIVE INTERLOCK:**
Prevents the breaker from closing between Connected & Test positions. (Fig. 4.2, Item 22.)
- (f) **POSITION CLOSING INTERLOCK:**
Prevents the breaker from closing automatically when moved from Test to Connected position if the closing switch is maintained during the levering in operation. (Fig. 4.2, Item 22.)
- (g) **POSITION WITHDRAWAL INTERLOCK:**
Prevents the breaker from being withdrawn by pulling unless it is in Test position. (Fig. 4.2, Item 3.)
- (h) **EXTENSION RAIL INTERLOCK:**
Prevents the breaker from being withdrawn out of enclosure unless the extension rails are engaged to fixed rails. (Fig. 4.2, Item 1.)

Check the correct operation of above interlocks as follows:

- At the conclusion of checks in section 4.8, the breaker is in the Test position, closed and springs charged.

- NOTE: DO NOT USE any tool to lever the breaker from Test or Connected position other than the levering crank provided. Correct operation of some of the interlocks is dependent upon use of the levering crank provided with the switchgear.
- Engage the levering crank handle. The breaker shall automatically trip and MOC switches shall operate. (If the breaker compartment is equipped with MOC switches that are required to operate in Test position.) (See Fig. 4.5c)
- Lever the breaker towards Connected position. As it begins to move towards the Connected position, shutters shall open freely. Breaker's movement into Connected position is indicated by red flag in front of the levering device. TOC switch shall also operate (if provided). Remove the levering crank. (See Fig. 4.5d)
- Close the breaker. MOC switches shall operate (if provided) and the motor closing springs start charging if control power is available.
- Attempt to engage the levering crank. The slider cannot be pushed far enough to engage levering crank. Trip the breaker, engage the levering crank and lever the breaker out approximately halfway towards Test position. (See Fig. 4.5c)
- Attempt to lift the breaker lift/pull handle and pull out the breaker. Position withdrawal interlock shall prevent lifting of the handle high enough to disengage the levering latch from the nut. In turn, the breaker cannot be pulled out. (See Fig. 4.6b)
- Attempt to close the breaker by pushing the manual close button. (See Fig. 4.3c). The breaker shall go "trip free." (Springs will discharge but the breaker will not close). Lever the breaker into Test position. Secondary Disconnects shall disengage automatically. Engage Disconnects by pulling them forward as far as possible. Close the breaker. The motor shall start charging springs automatically.
- Remove the extension rails. Disengage the levering latch by lifting the handle on the breaker and try to pull the breaker out. The breaker shall not move out more than two inches beyond Test position. Push the breaker to Test position. Engage extension rails. Disengage the levering latch again and pull the breaker out. The breaker shall trip, close, and trip as it comes out on the extension rails from Test position.

Correct operation indicates that the breaker is ready for installation.

CAUTION

BEFORE ENERGIZING THE PRIMARY CIRCUIT MAKE CERTAIN THAT ALL ENCLOSURE DOORS ARE CLOSED.



a. Engaging the Extension Rails Before Removing the Breaker



b. Pulling the Breaker Out on the Extension Rails Note That Lift/Pull Handle Must Be Lifted to Pull the Breaker Out

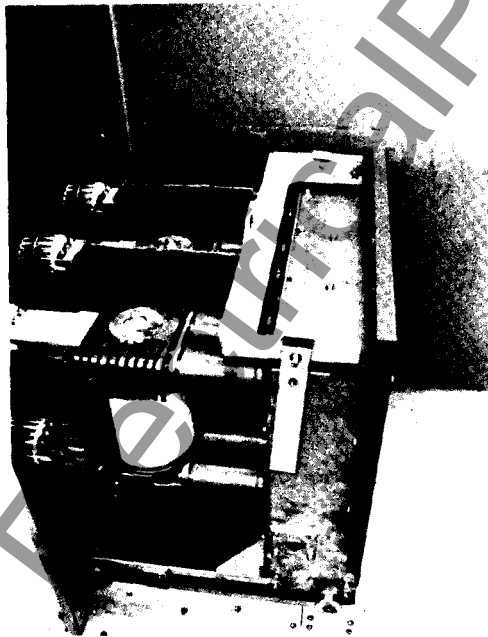

c. Showing the Lifting Yoke Engaged

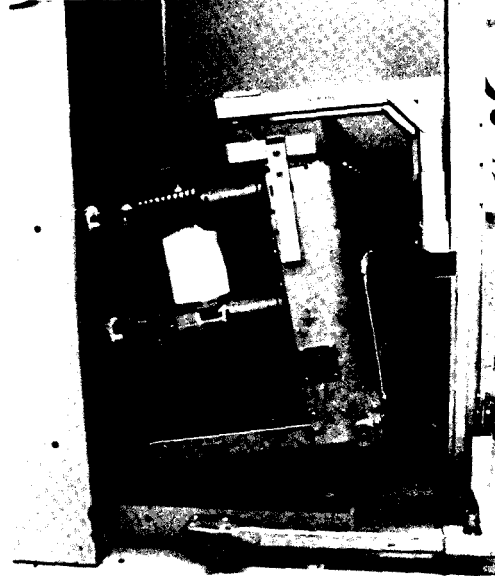

d. Lifting the Breaker with the Portable Lifter

Fig. 4.6 Type VCP-W Breaker – Being Removed from Enclosure

SECTION 5 – DESCRIPTION AND OPERATION

Westinghouse type VCP-W breakers are horizontal draw out vacuum circuit breakers. They are designed for use in VC-W Metal-Clad switchgear compartments. Most ratings can be stacked two high in a vertical section which results in considerable savings in floor space. They use vacuum interrupters to close and open the primary circuit. The mechanism is front mounted spring stored energy type which not only aids personnel safety but also provides ease of inspection and accessibility for servicing. The same basic mechanism is used for all ratings. Thus a minimum investment in spare parts is required. Due to the inherent long life characteristics of the vacuum interrupters and a highly reliable spring stored energy type mechanism, type VCP-W circuit breakers provide long trouble free service with minimum maintenance.

5.1 INTERRUPTER ASSEMBLY

The vacuum interrupter is mounted vertically and is supported from the fixed stem clamped to the top conductor. Current transfer from the fixed and moving stems of the interrupter are through a unique Westinghouse patented clamped joint. This design not only eliminates any need for lubrication and maintenance as required in typical sliding joints but also assures a reliable low resistance joint. Multiple finger type primary disconnecting contacts at the ends of the top and bottom conductors provide means for connecting and disconnecting the breaker to the primary stabs in the switchgear compartment.

A vacuum interrupter erosion indicator is located on the moving stem of the interrupter. It is visible when the breaker is withdrawn and is viewed from the rear of the breaker. (See Fig. 6.2)

5.1.1 VACUUM INTERRUPTER

The Type VCP-W breaker for VC-W Metal-Clad switchgear utilizes vacuum interrupters for interruption and switching functions. Vacuum interruption offers the advantages of enclosed interrupters, small size and weight, short interrupting time, long life, reduced maintenance and environmental compatibility (low noise, no arc by-products and minimum mechanical shock).

Arc interruption is simple and fast. In the closed position, current flows thru the interrupter. When the contacts are opened, an arc is drawn between the contact surfaces. It is rapidly moved around the slotted contact surfaces by self-induced magnetic force which prevent gross contact erosion and the formation of hot spots on the surfaces. The arc burns in an ionized metal vapor which continually leaves the contact area and condenses on the surrounding metal shield.

At current zero, the arc extinguishes: vapor production ceases. Very rapid dispersion, cooling, recombination, and deionization of the metal vapor plasma together with the fast condensation of metal vapor products cause the vacuum to be quickly restored. Hence the opened contacts withstand the transient recovery voltage.

5.1.2 CONTACT EROSION INDICATOR

The purpose of the Contact Erosion Indicator is to show the erosion of the Vacuum Interrupter contacts. When contact erosion reaches 1/8 inch, the interrupter assembly must be replaced. The contact erosion indicator is a mark located on the moving stem of the interrupter. See Fig. 6.2.

In order to determine if the contacts have eroded to the extent that the interrupter must be replaced, close the breaker and observe the erosion mark placed on each vacuum interrupter moving stem from the rear of the breaker. If the mark on the vacuum interrupter stem is visible, the interrupter is ok. If the mark is no longer visible, the interrupter assembly must be replaced.

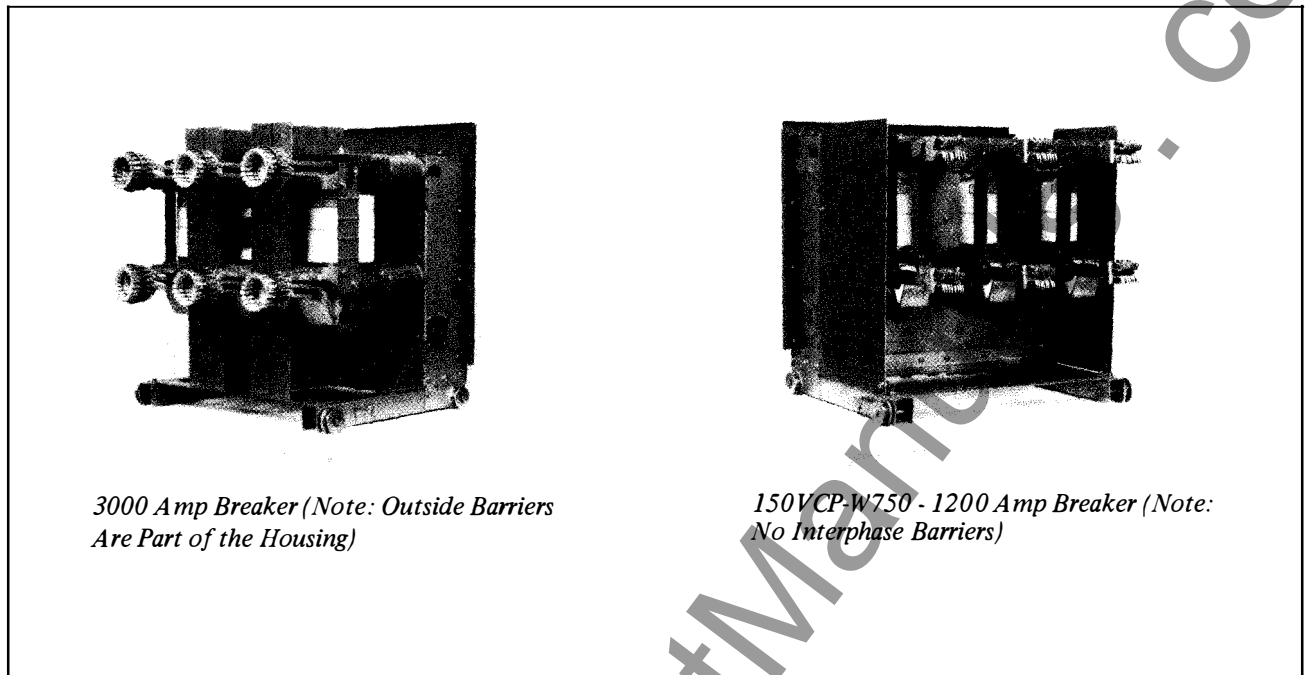

Fig. 5.1 VCP-W Breakers Showing Barriers

5.1.3 CONTACT WIPE AND STROKE

Wipe is the indication of (1) force holding the vacuum interrupter contacts closed and (2) energy to hammer the contacts open with sufficient speed for safe and clean interruptions.

Stroke is the gap between fixed and moving contacts of vacuum interrupter with the breaker open.

Circuit breaker mechanism provides fixed amount of motion to the operating rods. First portion of the motion is used to close the contacts (i.e. stroke) and the remainder is used to further compress preloaded wipe spring. This additional compression is called wipe. Wipe and stroke are thus related to each other. As the stroke increases due to erosion of contacts, the wipe decreases. A great deal of effort and ingenuity has been spent in design of the Type VCP-W breakers in order to eliminate any need for field adjustment of wipe or stroke. There is no provision for inservice adjustments. All such adjustments are factory set and should not be attempted in the field.

5.1.4 PHASE BARRIERS

Phase barriers on all VCP-W breakers are made from 1/8 inch thick glass polyester. See Figure 3.1. Table 5.1 gives the number and configuration of barriers required for each breaker rating.

CAUTION

The breaker should not be placed in its compartment unless the phase barriers are in place.

TABLE 5.1 VCP-W BREAKER BARRIER CONFIGURATIONS

BREAKER RATING	AMPS	VAC INTERRUPTER DIAMETER INCHES	NUMBER OF BARRIERS
50VCPW250	1200	4	2
	2000	5	4
	3000	7	2+2 in cell
50VCPW350	1200	7	2+2 in cell
	2000	7	2+2 in cell
	3000	7	2+2 in cell
75VCPW500	1200	5	4
	2000	5	4
	3000	7	2+2 in cell
150VCPW500	1200	4	2
	2000	5	4
	3000	7	2+2 in cell
150VCPW750	1200	4	2
	2000	5	4
	3000	7	2+2 in cell
150VCPW1000	1200	7	2+2 in cell
	2000	7	2+2 in cell
	3000	7	2+2 in cell

NUMBER OF BARRIERS – KEY

- 2 Exterior barriers on the breaker.
- 4 Exterior and interior barriers on the breaker.
- 2+2 in cell Interior barriers on the breaker along with 2 exterior barriers mounted on the sides of the cell.

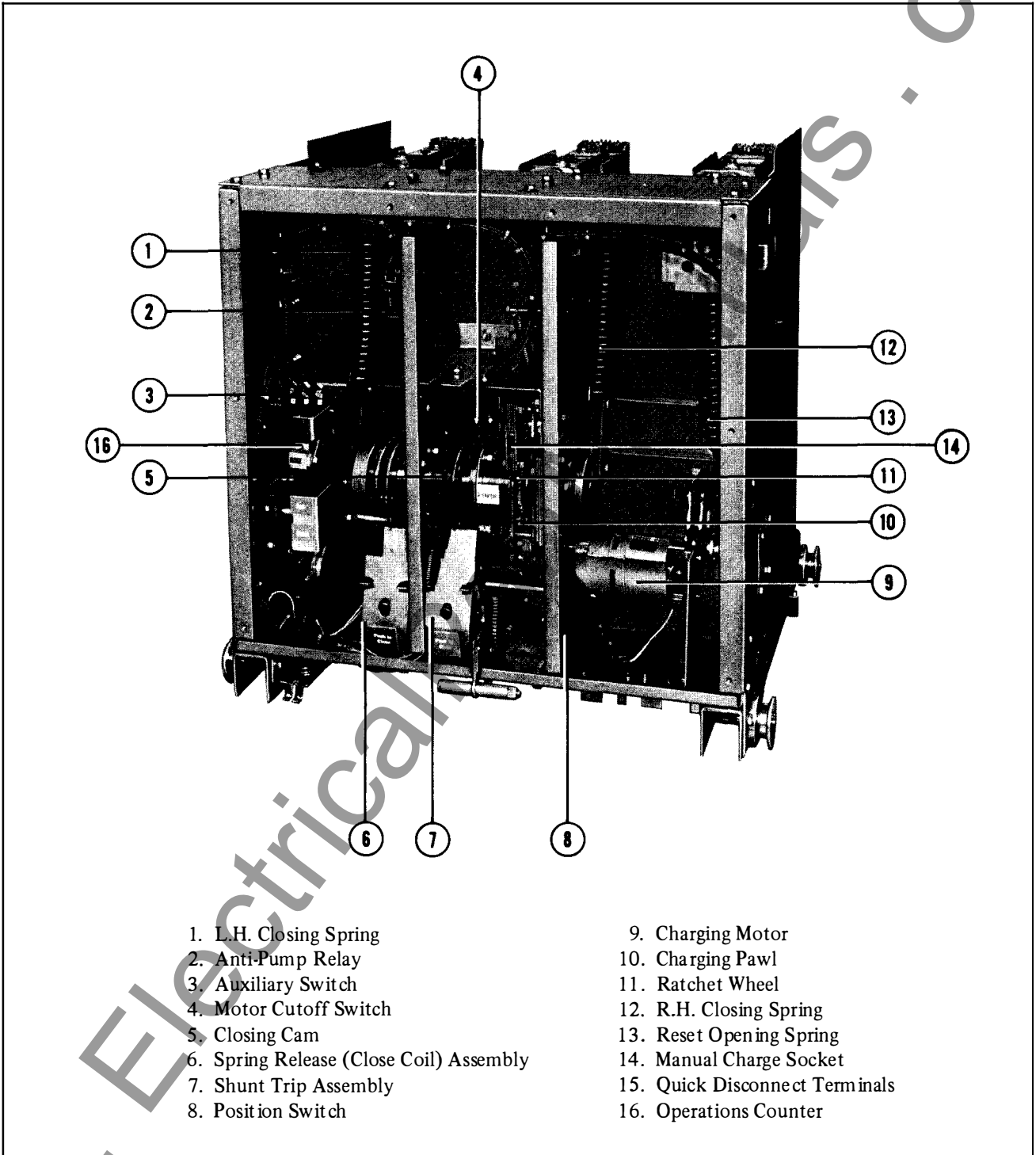

- | | |
|---|--------------------------------|
| 1. L.H. Closing Spring | 9. Charging Motor |
| 2. Anti-Pump Relay | 10. Charging Pawl |
| 3. Auxiliary Switch | 11. Ratchet Wheel |
| 4. Motor Cutoff Switch | 12. R.H. Closing Spring |
| 5. Closing Cam | 13. Reset Opening Spring |
| 6. Spring Release (Close Coil) Assembly | 14. Manual Charge Socket |
| 7. Shunt Trip Assembly | 15. Quick Disconnect Terminals |
| 8. Position Switch | 16. Operations Counter |

Fig. 5.2 VCP-W Breaker – Front Panel Removed

5.2 STORED ENERGY MECHANISM

The spring stored energy operating mechanism is arranged vertically in the front of the breaker. It includes all the elements for storing the energy, closing and tripping of the breaker, manual and electrical controls, and interlocks. Manual controls are all in the front and readily accessible. The vacuum interrupter assemblies are mounted on insulators on the rear of the mechanism assembly. Motion to close and open the interrupter contacts is provided through operating rods connecting the mechanism pole shaft to the bell cranks of the interrupter assemblies.

5.2.1 OPERATION OF STORED ENERGY MECHANISM

The mechanism stores the closing energy by charging the closing springs. When released, the stored energy closes the breaker, charges the wipe and reset springs. The mechanism may rest in any one of the four positions shown in Figure 5.3 as follows :

- a. Breaker open, closing springs discharged.
- b. Breaker open, closing springs charged.
- c. Breaker closed, closing springs discharged.
- d. Breaker closed, closing springs charged.

5.2.2 CHARGING

Figure 5.4 shows schematic views of the spring charging parts of the stored energy mechanism.

The major component of the mechanism is a cam shaft assembly which consists of a hex shaft to which are attached two closing spring cranks (one on each end), the closing cam, drive plates, and a free-wheeling ratchet wheel.

The ratchet wheel is actuated by an oscillating mechanism driven by motor eccentric. As the ratchet wheel rotates, it pushes the drive plates which in turn rotate the closing spring cranks and the closing cam with it.

The closing spring cranks have spring ends connected to them which are in turn coupled to the closing springs. As the cranks rotate, the closing springs get charged.

When the closing springs are completely charged, the spring cranks go over dead center and the closing stop roller comes against the spring release latch. The closing springs are now held in fully charged position.

The closing springs may also be charged manually as follows: Insert the maintenance tool in the manual charging socket (Fig. 4.3). Move it up and down several times (about 36) until clicking sound is heard and closing springs charging indicator shows "charged". Any further motion of the maintenance tool will result in free wheeling of the ratchet wheel and will not result into advance of charging.

5.2.3 CLOSING OPERATION

Figure 5.3 shows the positions of the closing cam and tripping linkage. Note that in Fig. 5.3a in which the breaker is open and the closing springs are discharged, the trip "D" shaft and the trip latch are in the unlatched position as in Fig. 5.3b.

The closing springs can be released to close the breaker by moving the spring release latch out of the way. This is done electrically or manually by depressing the spring release lever which turns the spring release latch out of the

- 1. Pole Shaft
- 2. Main Link
- 3. Banana Link
- 4. Trip Latch
- 5. Shunt Trip Lever
- 6. Shunt Trip Coil

- 7. Cam Shaft
- 8. Closing Cam
- 9. Operating Rod
- 10. Main Link Roller
- 11. Trip Bar "D" Shaft
- 12. Trip Latch Reset Spring

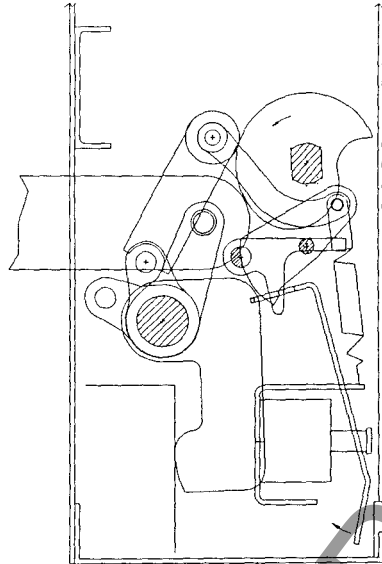

Fig. 5.3a Breaker Open and Closing Spring Not Charged

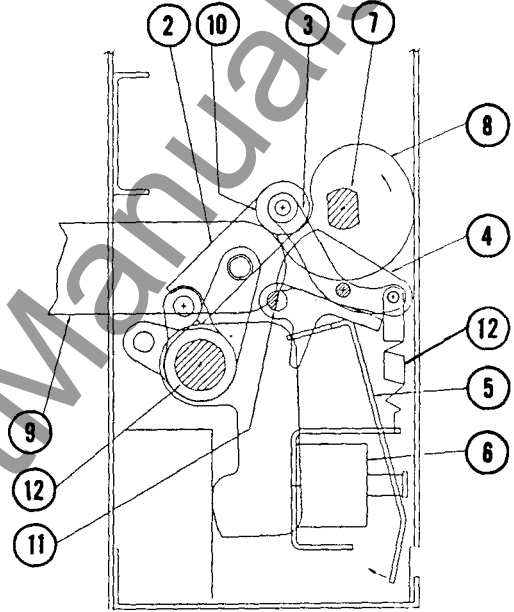

Fig. 5.3b Breaker Open and Closing Spring Charged

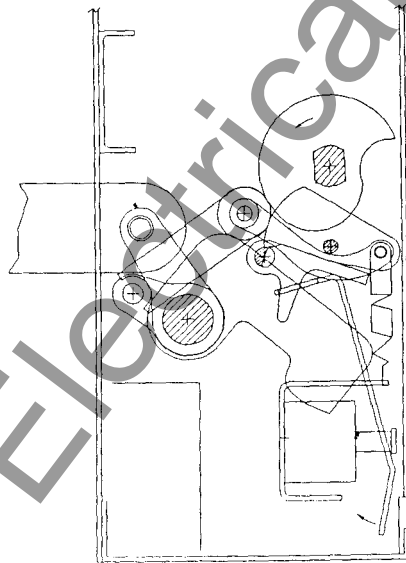

Fig. 5.3c Breaker Closed and Closing Spring Not Charged

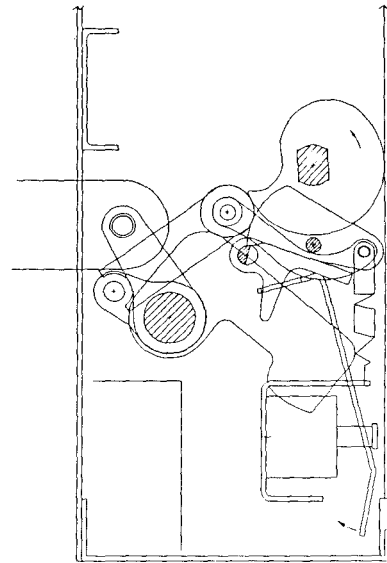

Fig. 5.3d Breaker Closed and Closing Spring Charged

Fig. 5.3 Closing Cam and Trip Linkage

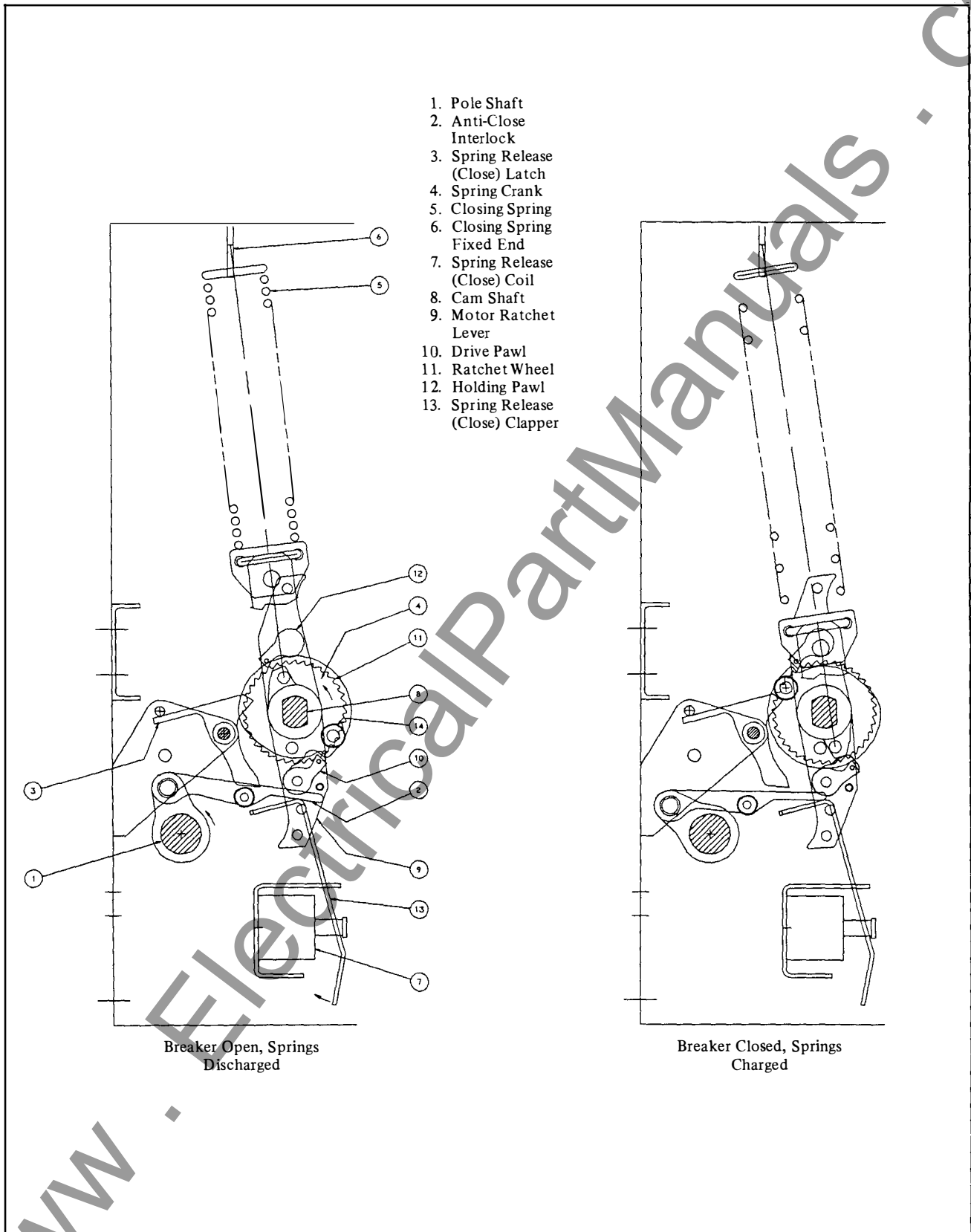

Fig. 5.4 Charging Schematic

way of the closing stop roller. The force of the closing spring rotates the cam shaft thru the spring cranks. The closing cam being attached to the cam shaft in turn rotates the pole shaft through the main link to close the breaker.

In Figure 5.3c the linkage is shown with the breaker in the closed position before the closing springs have been recharged. Interference of the trip "D" shaft with the trip latch prevents linkage from collapsing and holds the breaker closed.

Figure 5.3d shows the breaker in the closed position after the closing springs have been recharged. Note that the spring charging rotates the closing cam by one half turn. Since the cam surface in contact with the main link roller is cylindrical in this region, spring charging operation does not affect the mechanism linkage.

Since the primary contacts are completely enclosed in the vacuum interrupter and not adjustable in any way, "Slow Close" capability is not provided for this breaker.

5.2.4 TRIPPING OPERATION

When the trip "D" shaft is turned either by trip button or trip coil, all links return to the original "open" condition shown in Fig. 5.3a.

5.2.5 TRIP FREE OPERATION

When manual trip button is held depressed, any attempt to close the breaker ends up in discharge of closing springs without any movement of pole shaft or vacuum interrupter stem.

5.3 CONTROL SCHEME

There are two basic control schemes for type VCP-W breakers - one for DC control and one for AC control. See Fig. 5.5. There may be different control voltages or more than one tripping element, but the principal mode of operation is as follows:

As soon as the secondary disconnects make up, the spring charging motor automatically starts charging the closing springs provided the control power is available. When the springs are charged, the motor cut off (LS/bb) switch turns the motor off. The breaker may be closed by making up control switch close (CS/C) contact. Automatically upon closing of the breaker, the motor starts charging the closing springs. The breaker may be tripped any time by making up control switch trip (CS/T) contacts.

Note the position switch (PS) contact in spring release circuit in the scheme. This contact remains made while the breaker is being levered between Test and Connected position. Consequently it prevents the breaker from closing automatically even though control switch close contact may have been made while the breaker is levered to the Connected position.

When the CS/C contact is made, the SR closes the breaker. If the CS/C contact is maintained after the breaker closes, the Y relay is picked-up. The Y/a contact seals in Y until CS/C is opened. The Y/b contact opens the SR circuit so that even though the breaker would subsequently open, it could not be re-closed before the CS/C were released and remade. This is the anti-pump function.

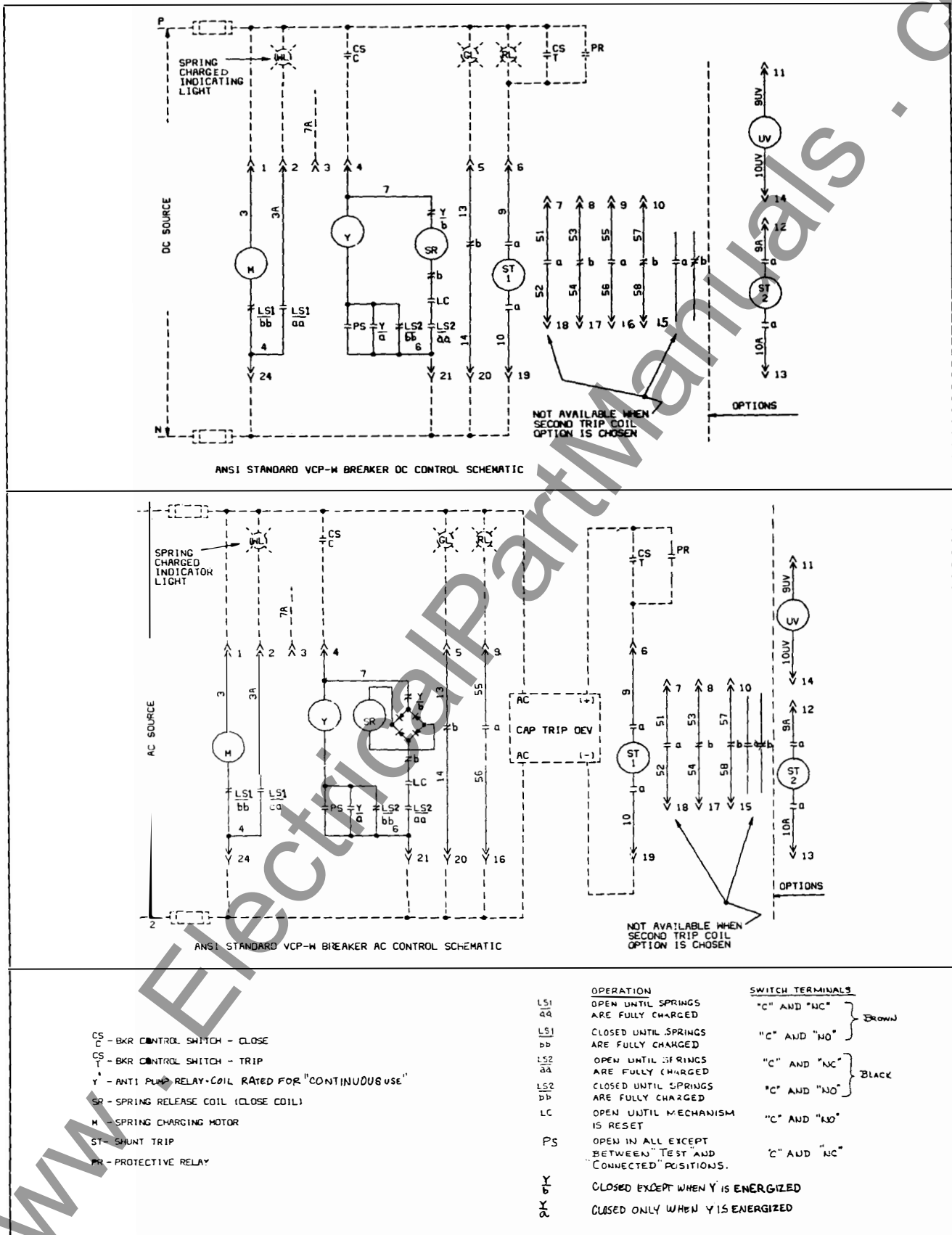

Fig. 5.5 Typical "DC" and "AC" Control Schemes

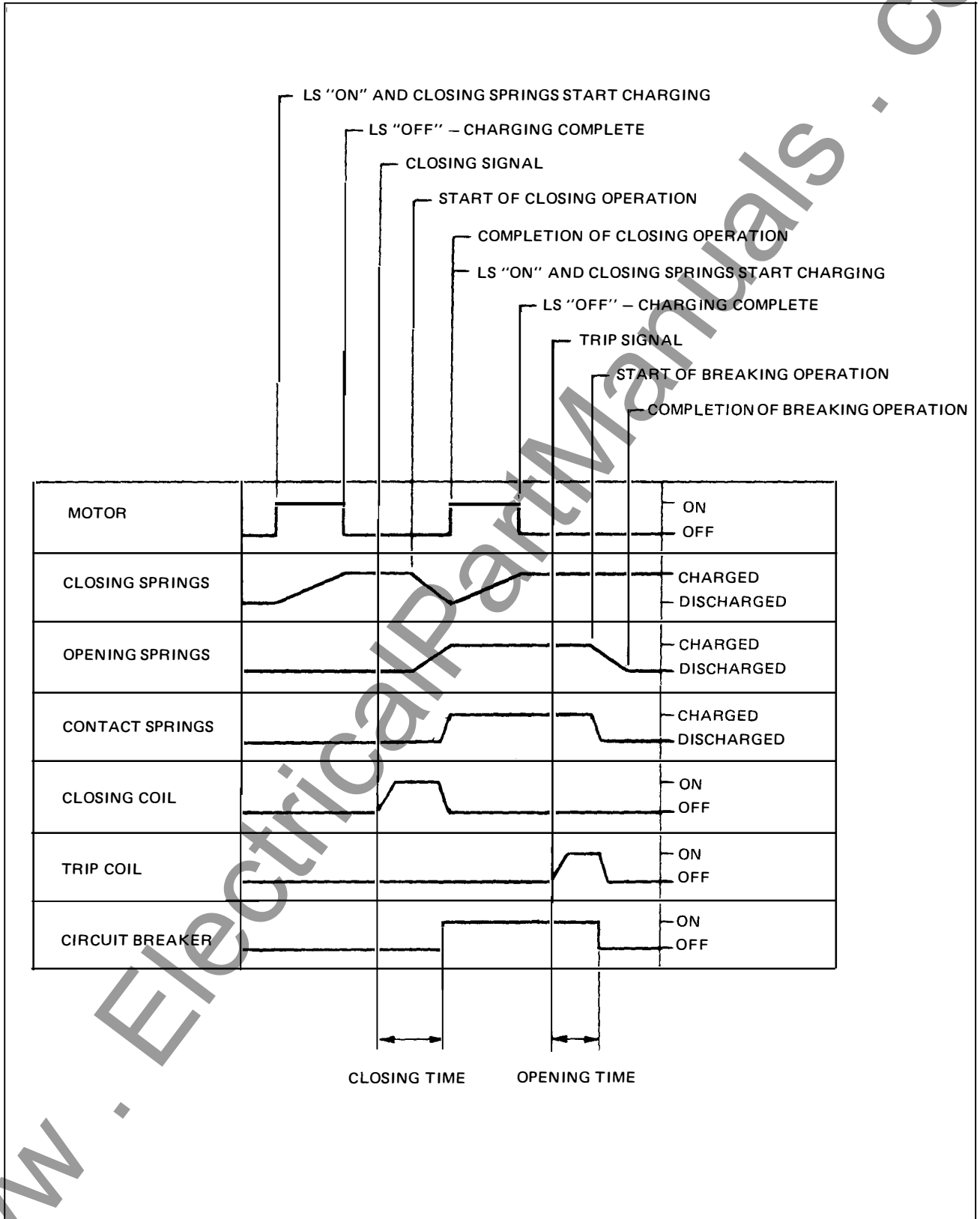

Fig. 5.6 VCP-W Breaker Charge-Close-Open Operation

5.3.1 TIMING

The opening and closing times for the circuit breakers vary depending upon the control voltage and the power rating. However, the typical ranges are as follows:

TABLE 5.3.1

Event	Time in Milliseconds
Closing Time (From Initiation of Close Signal to Contact Make)	45-60
Opening Time (Initiation of Trip Signal to Contact Break)	30-45
Reclosing Time (Initiation of Trip Signal to Contact Break)	140-165

5.3.2 SECONDARY DISCONNECTS

The breaker control wiring is arranged to connect a 25 point male plug with a corresponding female plug mounted in the switchgear compartment. The breaker plug is mounted on the left side under the bottom pan of the mechanism and it is fixed in that position. The female plug in the compartment is mounted on a movable carriage. See Figures 4.1 and 4.2. The secondary disconnects will engage automatically as the breaker is levered into the Connected position.

To engage the secondary contacts while the breaker is in Test position, raise the handle and pull the carriage all the way towards the front. This will latch the contacts. To disengage, simply push the carriage to the rear.

5.3.3 UNDERVOLTAGE TRIP DEVICE

The undervoltage trip device for VCP-W breakers is an electromechanical device that operates to open the breaker at 30% or less of the voltage rating of the trip coil. The device does not open the breaker at values above 60% of the voltage rating of its trip coil. However, 60% may operate to open the breaker when the voltage across the trip coil is greater than 30%, but is 60% or less of the voltage rating of its trip coil.

The circuit breaker can be closed as long as the voltage to the device trip coil is maintained at 85% or above the rated level.

The devices are available only in instantaneous type and rated voltages of 48 Vdc, 125 Vdc, and 250 Vdc.

With the breaker closed and sufficient voltage on the Undervoltage Trip Device coil, the moving clapper^① is held to the stationary yoke^② by the magnetic force (produced by the coil^③ against the extension springs^④ pulling the moving clapper apart from the yoke. The moving clapper is connected to the mechanism Trip D Shaft lever^⑤ by a slotted link^⑥. When the voltage to the Undervoltage Trip Coil goes down as described earlier, the extension springs force overcome reduced magnetic force and pull the moving clapper up. The slotted link in turn upsets the Trip D Shaft and the breaker trips open.

As the breaker opens, the reset lever^⑦ connected to the pole shaft lever^⑧ operates to reset the moving clapper. As long as the breaker remains open, the reset lever holds down the moving clapper to the yoke. When the breaker

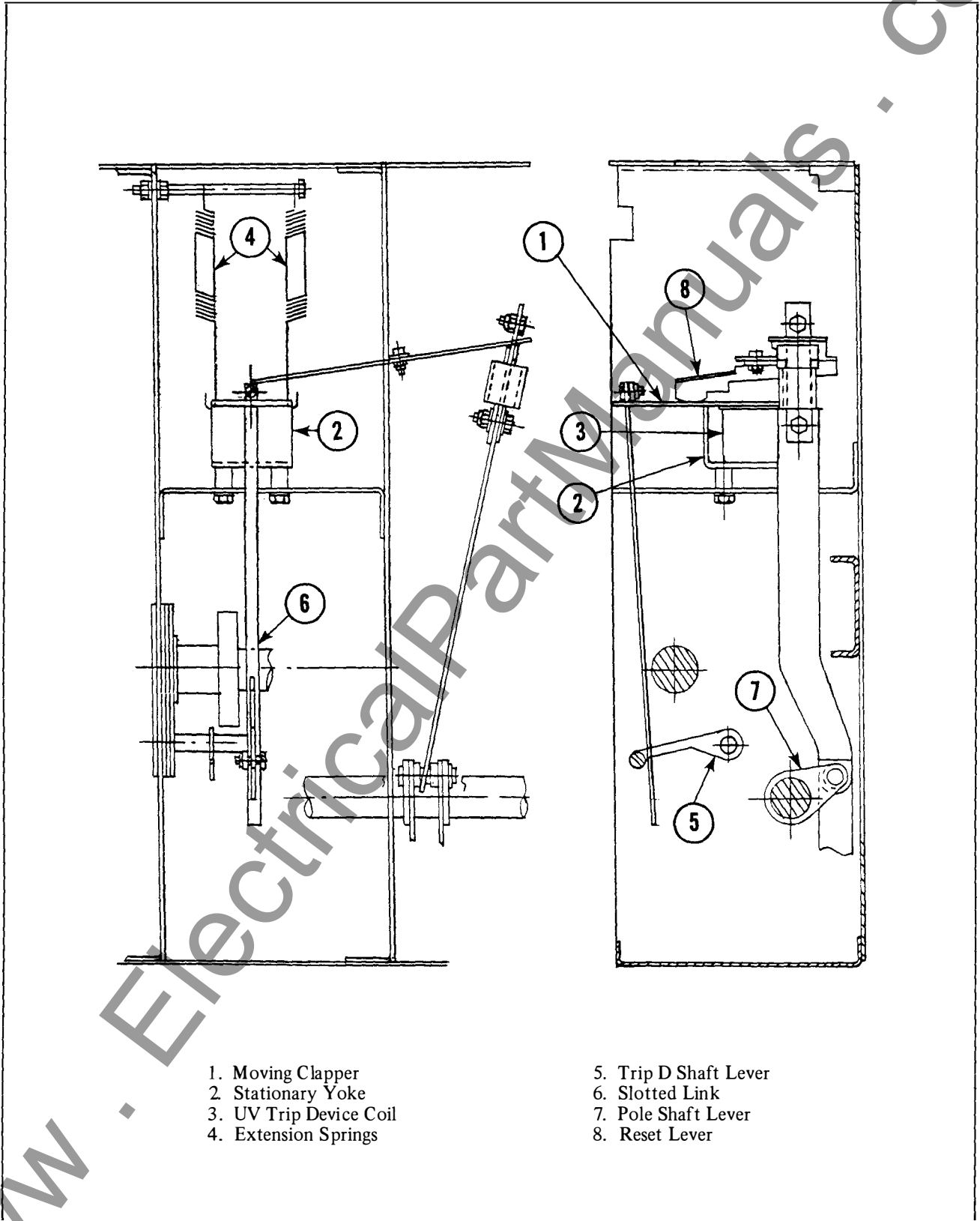

Fig. 5.7 Undervoltage Trip Device Configuration

closes, the reset lever moves away from the moving clapper. If the Undervoltage Trip Device coil has at least 85% of the rated voltage, the moving clapper is held to the yoke by the magnetic force, even though the reset lever has moved up.

5.4 INTERLOCKS

All VCP-W breakers are equipped with several interlocks. These interlocks permit proper and safe breaker operation.

CAUTION

CONDITIONS HAZARDOUS TO PERSONNEL, EQUIPMENT AND PROPERTY CAN BE CREATED SHOULD ANY OF THE INTERLOCKS BE BY-PASSED OR MADE INOPERATIVE.

5.4.1 BREAKER-COMPARTMENT CODE PLATES (POWER RATING INTERLOCK)

A set of two code plates on the breaker and two in the compartment form this interlock. It is intended to prevent the insertion of a lower rated breaker into a higher rated compartment. The ratings are based on continuous current, interrupting current, close and latch current and maximum voltage. Breakers with the same or higher ratings in all of the above categories, can be inserted into compartments of equal or lower rating. If the ratings do not agree, the breaker cannot be inserted into the Test position. See Figure 4.1.

NOTE: Code plates do not block out control voltage or scheme incompatibility.

5.4.2 POSITIVE INTERLOCK

The purpose of this interlock is to prevent engaging the levering crank when the breaker is closed and in the Connected position. A tab on the right hand side of the levering slide cage interferes with the breaker MOC switch operator thus preventing the slide from moving far enough to permit engagement of the levering crank. See Figs. 4.1 and 4.2.

5.4.3 ANTI-CLOSE INTERLOCK

This interlock prevents releasing the closing springs electrically or manually if the breaker is already closed (see Figure 5.4). On a closed breaker, the interlock lever moves toward the rear. In this position, the movement of the spring release clapper does not lift the lever and thus the spring release latch cannot be moved.

5.4.4 FLOOR TRIPPING AND SPRING RELEASE INTERLOCKS

These interlocks are operated by the interaction between the floor tripper rollers Figure 4.1 on the bottom of the breaker and levering device rails. They perform several functions:

1. Hold the breaker trip free between the Test and Connected positions. The latch check switch is also held open thus preventing any electrical close signal from closing the breaker, (negative interlock).
2. Permit the breaker to be withdrawn in safe mode (breaker open, springs discharged) when moved from the Test to the withdrawn position or vice versa, (maintenance interlock).
3. Trip the breaker (if closed) before being levered from Test position, (levering interlock).

The above functions are accomplished by pushing up the tripper rollers which in turn rotate the trip "D" shaft or spring release latch.

5.5 MISCELLANEOUS

5.5.1 GROUND CONTACT

The Ground Contact is an assembly of spring loaded fingers to provide a means for grounding the breaker chassis when it is inserted into the switchgear compartment. The ground contact is located on the left side of the breaker under the mechanism bottom pan. An extension of the switchgear ground bus is secured to the compartment floor in such a position to engage the ground contact when the breaker is pushed into the Test position and to remain engaged in all positions up to the Connected position. (See Figures 4.1 and 4.2.)

5.5.2 MOC AND TOC SWITCH OPERATORS

As shown in figure 4.1, the MOC (Mechanism Operated Control) switch operator is coupled to the pole shaft. In the Test and Connected positions of the breaker, this operator aligns directly above the MOC switch bell crank levers in the compartment. As the breaker closes, the operator moves down and pushes the bell crank lever to change the MOC switch contact position. Thus, MOC switch contacts operate in the same manner as the auxiliary switch contacts in the breaker. (Note that the MOC switch operator is provided on all breakers but MOC switches in the compartment are provided only when specified on the switchgear order).

As shown in Figure 4.1, the TOC (Truck Operated Control) switch operator is mounted inside the right foot of the breaker. It operates the TOC switch as the breaker moves to the Connected position in the switchgear compartment.

5.5.3 OPERATIONS COUNTER

All breakers are equipped with the mechanical operations counter. As the breaker opens, the linkage connects to the pole shaft lever advancing the counter reading by one. (See Fig. 5.2.)

5.6 LEVERING DEVICE

The purpose of the Levering Device is to move the circuit breaker between the Test and Connected positions. For VCP-W breakers, the device is a drive screw and drive nut. Although the device is mounted in the switchgear compartment, a brief description here will help understanding the operation. See Figures 4.1 and 4.2.

The levering device consists of a drive screw, a drive nut, two side rails and a sliding cage. In the Test position, the nut is all the way to the front. As the breaker is pushed in, the levering latch snaps on the nut. Turning the crank clockwise while pushing forward advances the breaker toward the Connected position. During this travel, the floor tripper "Trip" roller is lifted up holding the breaker trip free. When the breaker reaches the Connected position, the crank cannot be turned any further. A red flag, shown in figure 4.2, indicates that the breaker is fully engaged.

If the breaker is closed in the Connected position, the slider cannot be pushed forward to permit engagement of the levering crank. After tripping the breaker, the levering crank may be engaged and the breaker withdrawn to the Test position by turning the crank counterclockwise. This position is indicated by no further motion of the crank.

The breaker levering latch may be disengaged only when the breaker is in the Test position, by lifting the latch release. As the breaker is withdrawn, it comes out with the contacts open and the springs discharged because of the floor tripping and spring release interlocks.

SECTION 6 – INSPECTION AND MAINTENANCE

6.1 When performing any maintenance, be sure about the following:

- Do not work on a breaker in the "Connected" position.
- Do not work on a breaker with secondary disconnects engaged.
- Do not work on a breaker with springs charged or contacts closed.
- Do not defeat any safety interlocks.
- Do not leave maintenance tool in the socket after charging the closing springs.
- Do not stand less than one meter away from the breaker when testing for vacuum integrity.

6.2 FREQUENCY OF INSPECTION

Inspect the breaker once a year when operating in a clean, non corrosive environment. For a dusty and corrosive environment, inspection should be performed twice a year. Additionally, it is recommended to inspect the breaker every time it interrupts fault current.

Refer to the table on following page for maintenance and inspection check points.

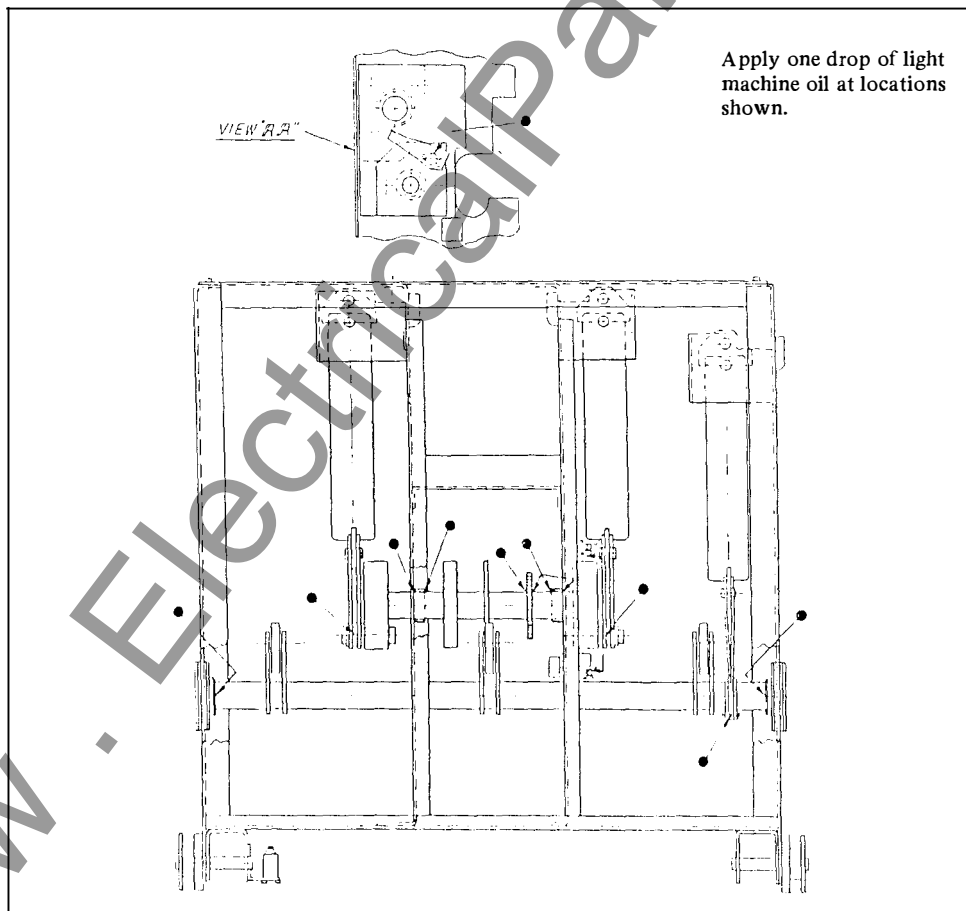

Fig. 6.1 Lubrication Points

6.3 INSPECTION AND MAINTENANCE

No./Section	Inspection Item	Criteria	Inspection Method	Corrective Action if Necessary
1	Insulation	Stand off insulators, operating rods, tie-bars and barriers	No dirt Visual check	Clean with lint-free cloth.
			No cracking Visual check	Replace entire pole unit if cracked.
Insulation Integrity	Main Circuit to Ground.	Withstand 27 kv, 60 Hz for 1 minute.	Hipot Tester	Clean and retest or replace.
	Between Main Circuit Terminals.	Withstand 27 kv, 60 Hz for 1 minute.	Hipot Tester	Clean and retest or replace.
	Control Circuit to Ground.	Withstand 1125V, (60 Hz) for 1 minute.	Hipot Tester	Clean and retest or replace.
2	Power Elements	Vacuum Interrupters	Contact wear - visibility of mark. Visual - Close the breaker and look for green mark on moving stem from the rear of the breaker (see Fig. 6.2).	If mark is not visible, replace interrupter assembly.
			Adequate Vacuum See Section 6.4.	Replace interrupter assembly if vacuum is not adequate.
			Dirt on ceramic body. Visual check	Clean with dry lint-free cloth.
3	Control Circuit Parts	Primary Disconnects	No burning or damage Visual check	Replace if burned, damaged or eroded.
		Closing and tripping devices including disconnects.	Smooth and correct operation by control power. Test closing and tripping of the breaker twice.	Replace any defective device - Identify per troubleshooting chart.
4	Operating Mechanism	Wiring	Securely tied in proper place. Visual check	Repair or tie as necessary
		Terminals	Tight Visual check	Tighten or replace if necessary.
		Motor	At-5000 Operations Check Counter	Replace brushes.
		Tightness of hardware.	No loose or missing parts. Visual and tightening with appropriate tools.	Tighten or reinstate if necessary.
	Dust or foreign matter.	No dust or foreign matter. Visual check	Clean as necessary.	
	Lubrication	Smooth operation and no excessive wear. Sight and feel	Lubricate very sparingly with light machine oil.	
	Deformation or excessive wear.	No excessive deformation or wear. Visual and operational.	Remove cause and replace parts.	
	Manual operation.	Smooth and crisp operation. Manual charging closing and tripping.	Correct per troubleshooting chart if necessary.	

Torque Required to Tighten the Bolts

Bolt Size	8-32	10-32	25-20	31-18	38-16	50-13
Torque Lb. In.	24	36	72	144	300	540

6.4 VACUUM INTERRUPTER INTEGRITY TEST

Vacuum interrupters used in type VCP-W circuit breakers are highly reliable interrupting elements. Satisfactory performance of these devices is dependent upon the integrity of the vacuum in the interrupter and the internal dielectric strength. Both these parameters can be readily checked by a one minute 27 kV ac rms high potential test. During this test, the following caution must be observed:

CAUTION

APPLYING ABNORMALLY HIGH VOLTAGE ACROSS A PAIR OF CONTACTS IN VACUUM MAY PRODUCE X-RADIATION. THE RADIATION MAY INCREASE WITH THE INCREASE IN VOLTAGE AND/OR DECREASE IN CONTACT SPACING. X-RADIATION PRODUCED DURING THIS TEST WITH RECOMMENDED VOLTAGE AND NORMAL CONTACT SPACING IS EXTREMELY LOW AND WELL BELOW MAXIMUM PERMITTED BY STANDARDS. HOWEVER, AS A PRECAUTIONARY MEASURE AGAINST POSSIBILITY OF APPLICATION OF HIGHER THAN RECOMMENDED VOLTAGE AND/OR BELOW NORMAL CONTACT SPACING, IT IS RECOMMENDED THAT ALL OPERATING PERSONNEL STAND AT LEAST ONE METER AWAY IN FRONT OF THE BREAKER.

With the breaker open and securely resting either on the extension rails or the floor, connect all top primary studs (bars) together and to the high potential machine lead. Connect all bottom studs together and ground them along with the breaker frame. Start the machine at zero potential, increase to 27 kV ac rms, 60 Hz and maintain for one minute. Successful withstand indicates that all interrupters are satisfactory. If there is a breakdown, the defective interrupter or interrupters should be identified by an individual test and replaced before placing the breaker in service.

After the high potential is removed, discharge any electrical charge that may be retained, particularly from the center shield of vacuum interrupters. To avoid any ambiguity in the ac high potential test due to leakage or displacement (capacitive) current, the test unit should have sufficient volt-ampere capacity. It is recommended that the equipment be capable of delivering 25 milliamperes for one minute.

Although an ac high potential test is recommended, a dc test may be performed if only a dc test unit is available. In this case the 40 k Vdc test, equipment must be capable of delivering 5 milliamperes for one minute to avoid ambiguity due to field emission or leakage currents.

The current delivery capability of 25 mA ac and 5 mA dc apply when all three VIs are tested in parallel. If individual VIs are tested, current capability may be one third of these values.

Note that the indicated high-potential test voltages of 27 kV ac rms and 40 kV dc apply irrespective of whether the breaker voltage rating is 5 kV, 7.5 kV, or 15 kV.

CAUTION

Some DC high potential units, operating as unfiltered halfwave rectifiers, are not suitable for use to test vacuum interrupters because the peak voltage appearing across the interrupters can be substantially greater than the value read on the meter.

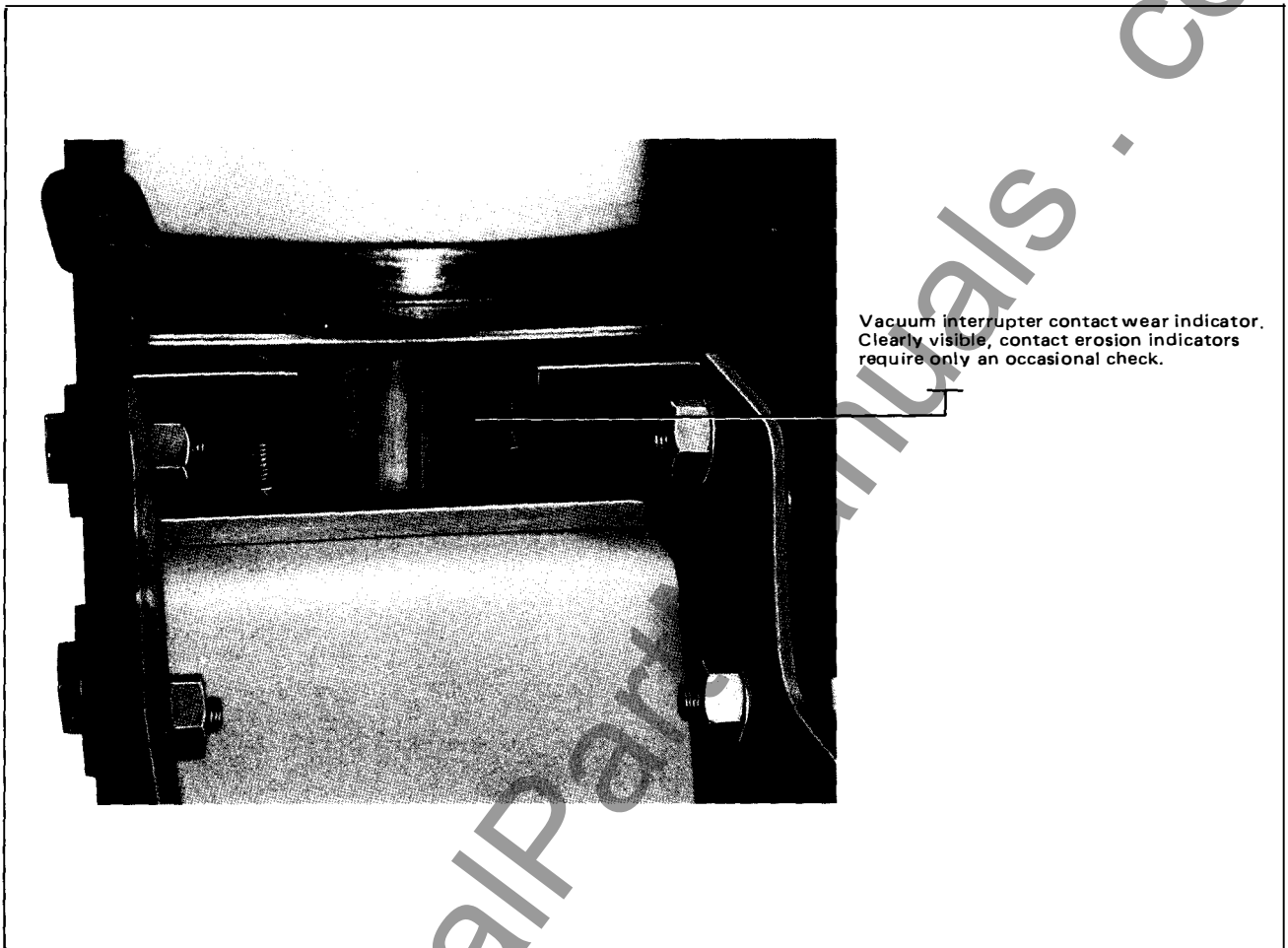

Fig. 6.2 *Vacuum Interrupter Showing Contact Erosion Indicator*

6.5 CONTACT EROSION AND WIPE

Since the contacts are contained inside the interrupter, they remain clean and require no maintenance. However, during high current interruptions there may be a minimal amount of erosion from the contact surfaces. Maximum permitted erosion is 1/8 inch. To determine contact erosion, close the breaker and observe the vacuum interrupter moving stem from the rear of the breaker. If the mark on each stem is visible, erosion has not reached maximum value thus indicating satisfactory contact surface of the interrupter. If the mark is not visible, the vacuum interrupter assembly must be replaced.

The adequacy of contact wipe can be determined by simply observing the vacuum interrupter side of the operating rod assembly on a closed breaker. (See Figure 6.3.)

If the wipe is not adequate, the vacuum interrupter assembly (Pole Unit) must be replaced. No field adjustment is possible.

It is extremely unlikely that the contact erosion will reach 1/8 inch during normal lifetime of the breaker. If it does, the vacuum interrupter assembly must be replaced.

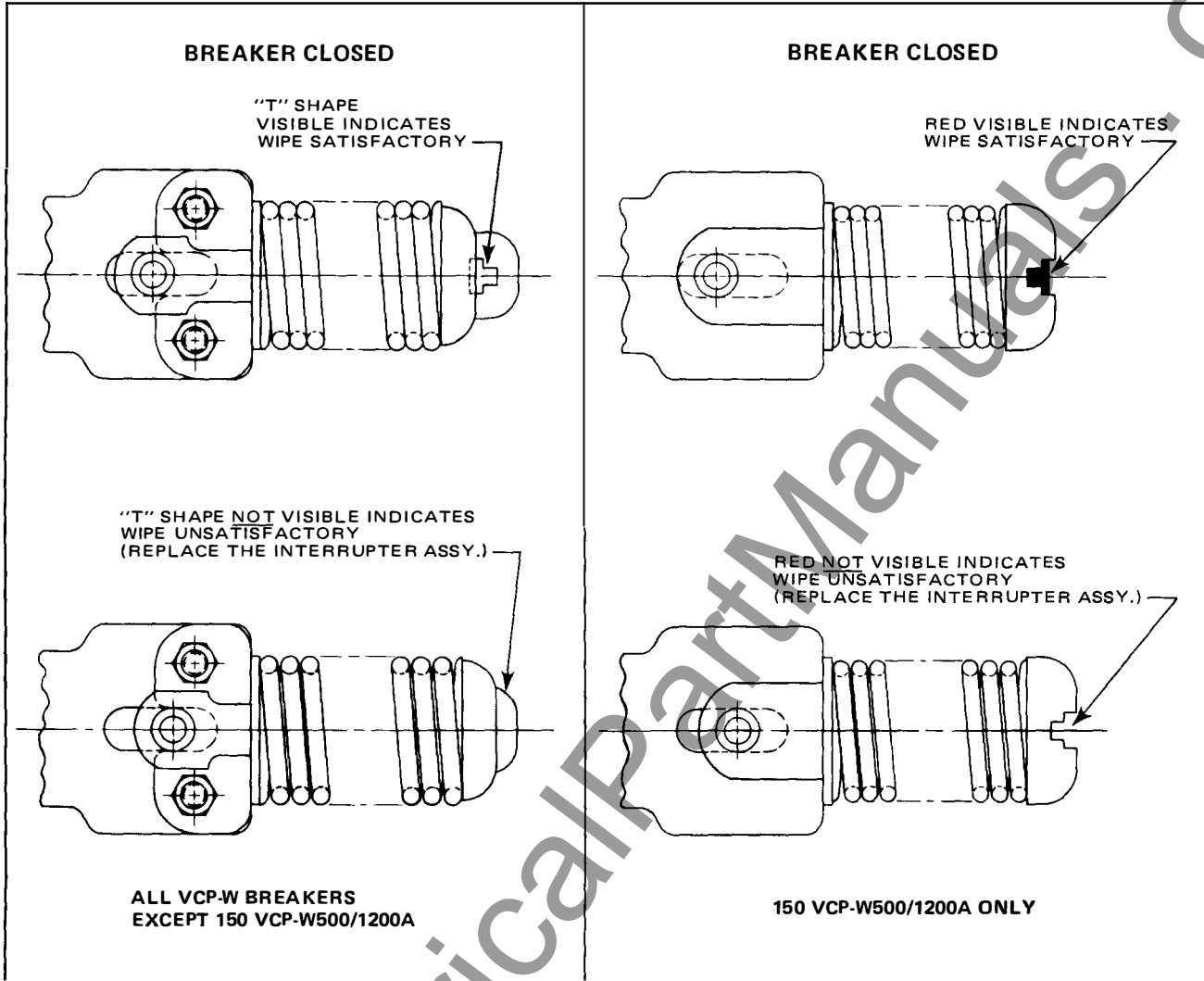

Fig. 6.3 Wipe Indication

6.6 INSULATION

In VCP-W breakers, insulation maintenance primarily consists of keeping and insulating surfaces clean. This can be done by wiping off all insulating surfaces with a dry lint free cloth or dry paper towel. In case there is any tightly adhering dirt that will not come off by wiping, it can be removed with a mild solvent or distilled water. But be sure that the surfaces are dry before placing the breaker in service. If a solvent is required to cut dirt, use Stoddard's Solvent Westinghouse 55812CA or commercial equivalent. Secondary control wiring requires inspection for tightness of all connections and damage to insulation.

6.7 INSULATION INTEGRITY CHECK

PRIMARY CIRCUIT :

The integrity of primary insulation may be checked by the ac high potential test. The test voltage depends upon the maximum rated voltage of the breaker. For the breakers rated 4.76 kV, 8.25 kV, and 15 kV, the test voltages are 15 kV, 27 kV and 27 kV RMS, 60 Hz respectively. Conduct the test as follows:

Close the breaker. Connect the high potential lead of the test machine to one of the poles of the breaker. Connect the remaining poles and breaker frame to ground. Start the machine with output potential at zero and increase to the test voltage. Maintain the test voltage for one minute. Repeat for the remaining poles. Successful withstand indicates satisfactory insulation strength of the primary circuit.

If a DC high potential machine is used, make certain that the peak voltage does not exceed the peak of the corresponding AC RMS test voltage.

SECONDARY CIRCUIT

Isolate the motor by pulling apart the two insulated quick disconnecting terminals in the two motor leads provided for this purpose (see Figure 5.2). Connect all points of the secondary disconnect pins with a shooting wire. Connect this wire to the high potential lead of the test machine. Ground the breaker frame. Starting with zero, increase the voltage to 1125 RMS, 60 Hz. Maintain the voltage for one minute. Successful withstand indicates satisfactory insulation strength of the secondary control circuit. Remove the shooting wire and reconnect the motor leads.

6.8 PRIMARY CIRCUIT RESISTANCE CHECK

Since the main contacts are inside the vacuum chamber they remain clean and require no maintenance at any time. Unlike most typical circuit breaker designs, VCP-W breakers do not have sliding contacts at the moving stem either. Instead they use a highly reliable and unique flexible clamp designed that eliminates the need for lubrication and inspection for wear.

If desired, the DC resistance of the primary circuit may be measured as follows: close the breaker, pass at least 100 amps DC current through the breaker. With the low resistance instrument, measure resistance across the studs on the breaker side of the disconnects for each pole. The resistance should not exceed 60, 40, 20 micro-ohms for 1200, 2000, and 3000 amp respectively.

6.9 MECHANISM CHECK

Make a careful visual inspection of the mechanism for any loose parts such as bolts, nuts, pins, rings, etc. Check for excessive wear or damage to the breaker components. Operate the breaker several times manually and electrically.

Check the closing and opening times to verify that they are in accordance with the limits in Table 5.3.1.

6.10 LUBRICATION

All parts that require lubrication have been lubricated during the assembly with molydenum disulphide grease, Westinghouse M No. 53701QB. Over a period of time, this lubricant may be pushed out of the way or degrade. Proper lubrication at regular intervals is essential for maintaining the reliable performance of the mechanism. Once a year or every 2000 operations (1000 operations for 3000 amp breaker) whichever comes first, the breaker should be relubricated. The locations shown in Figure 6.1 should be lubricated with a drop of light machine oil.

After lubrication, operate the breaker several times manually and electrically.

Roller bearings are used on the pole shaft, the cam shaft, the main link and the motor eccentric. These bearings are packed at the factory with a top grade slow oxidizing grease which normally should be effective for many years. They should not be disturbed unless there is definite evidence of sluggishness, dirt or parts are dismantled for some reason.

If it becomes necessary to disassemble the mechanism, the bearings and related parts should be thoroughly cleaned, remove old grease in a good grease solvent. Do not use carbon tetrachloride. They should then be washed in light machine oil until the cleaner is removed. After the oil has been drawn off, the bearings should be packed with Westinghouse Grease 53701QB or equivalent.

6.11 TROUBLESHOOTING CHART

<u>SYMPTOM</u>	<u>INSPECTION AREA</u>	<u>PROBABLE DEFECTS</u>
<u>FAILS TO CLOSE</u> -Closing Springs not charged	-Control Circuit -Mechanism	-Control Power (Fuse Blown or Switch off) -Secondary Disconnects (Pins 1 and or 24 not engaging) -Motor Cut-off Switch (Poor or burned contacts. Lever not operational.) -Terminals and connectors (Poor or burned contacts) -Motor (Brushes worn or commutator segment open) -Pawls (Slipping or broken) -Ratchet Wheel (Teeth worn or broken) -Cam Shaft Assy. (Sluggish or jammed) -Oscillator - (Reset spring off or broken)

SYMPTOM

FAILS TO CLOSE

-Closing Springs
Charged but breaker
does not close

INSPECTION AREA

No Closing Sound
(Close Coil does not-----
pick up)

PROBABLE DEFECTS

- Control Power
(Fuse blown or switch off)
- Secondary Disconnects
(Pins 4 and or 21 not engaging)
- Anti Pump Relay
(Y relay N.C. contact
open or burned or
relay picks up)
- Close Coil
(Open or burned)
- Latch Check Switch
(Contact open - Bad
switch or trip bar not reset)
- Auxiliary Switch
(b contact open or burned)
- Motor Cut off/
Limit Switch
(Contacts open or burned)
- Trip Coil Assy.
(Clapper fails to reset)
- Pole Shaft
(Not open fully)
- Trip Latch Reset Springs
(Damaged or missing)
- Trip Bar - D Shaft
(Fails to remain reset)
- Trip Latch - Hatchet
(Fails to remain reset)
- Trip Floor Tripper
(Fails to remain reset)
- Close Latch
(Binding)
- Close Latch Roller
Binding
- Trip Circuit Energized

-Closing Sound-----
But no Close

UNDESIRABLY TRIPS

-Control Circuit-----

- Close Circuit
(CS/C Getting
shorted)
- Close Release
Latch
(Fails to reset)

-Mechanism-----

- Close Floor
Tripper
(Fails to reset)

SYMPTOM
FAILS TO CLOSE **INSPECTION AREA** **PROBABLE DEFECTS**

-No Trip Sound-----	-Control Circuit-----	-Control Power (Fuse blown or switch off)
		-Secondary Disconnects (Pins 6 and or 19 not engaging)
		-Auxiliary Switch (a contacts not making poor or burned)
		-Trip Coil (Burned or open)
		-Terminals & Connections (Poor or burned or open)
	Trip Mechanism-----	-Trip Clapper (Jammed)
		-Trip Bar, Trip Latch (Jammed)
-Trip Sound----- But no trip	Trip Mechanism-----	-Pole Shaft (Jammed)
		-Operating Rod Assembly (Broken or pins out)
	-Vacuum Interrupter (One or more Welded)	

UNDESIRABLY TRIPS

-----	-Control Circuit-----	-Control Power (CS/T Switch, remains made)
		-Trip Coil Clapper (Not resetting)
	-Mechanism-----	-Trip Bar or Trip Latch (Poor engagement of mating or worn surfaces)
		-Trip Bar Reset Spring (Loss of torque)

SECTION 7 – RENEWAL PARTS AND ACCESSORIES

GENERAL



In order to minimize production downtime, it is recommended that an adequate quantity of spare parts be carried in stock. The quantity will vary from customer to customer, depending upon the service severity and continuity requirements. Each customer should develop his own stock level based on operating experience.



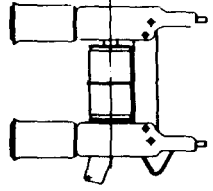
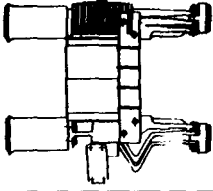
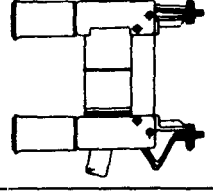
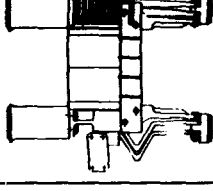
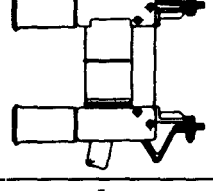
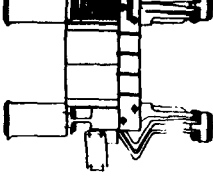

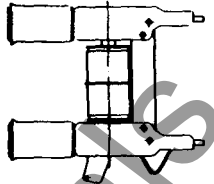
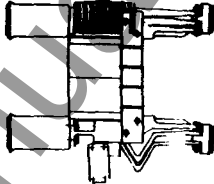
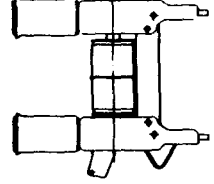
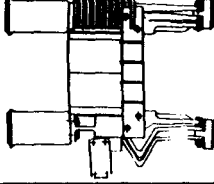
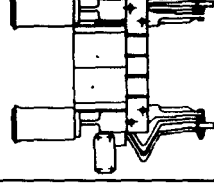
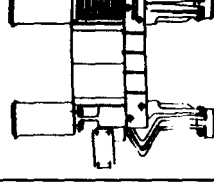
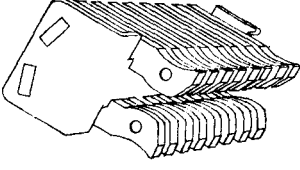
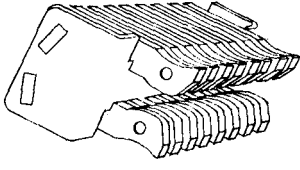

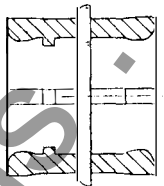
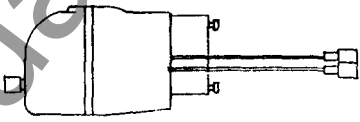
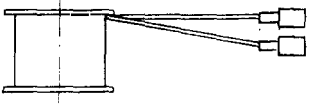
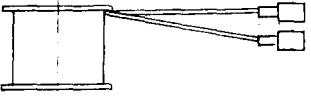
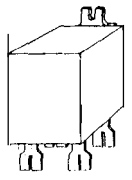
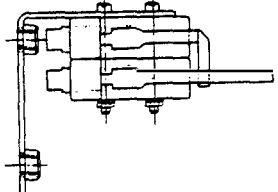
The following items in the quantity specified may be used as a guide:

7.1 RECOMMENDED RENEWAL PARTS FOR VCP-W CIRCUIT BREAKERS

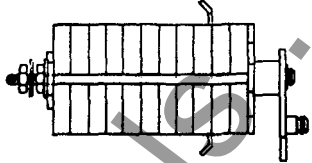
Line No.	Description	Style No.	Qty.	
01	Interrupter Assembly	8297A02H01	3	
02	50VCPW250-1200A-58 kA	8297A05H01	3	
03	50VCPW250-2000A-58 kA	8297A03H01	3	
04	50VCPW250H-2000A-78 kA	8297A06H01	3	
05	50VCPW250-3000A-58 kA	8297A04H01	3	
06	50VCPW250H-3000A-78 kA	8297A07H01	3	
07	50VCPW350-1200A-78 kA	8297A08H01	3	
08	50VCPW350-2000A-78 kA	8297A09H01	3	
09	50VCPW350-3000A-78 kA	8297A10H01	3	
10	75VCPW500-1200A-66 kA	8297A11H01	3	
11	75VCPW500-2000A-66 kA	8297A12H01	3	
12	75VCPW500-3000A-66 kA	8297A13H01	3	

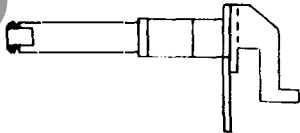
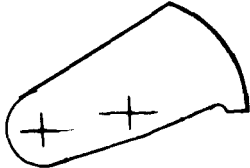
Line No.	Description	Style No.	Qty.	
13	Interrupter Assembly 150VCPW500-1200A-37 kA	8297A17H01	3	
14		8297A20H01	3	
15		8297A18H01	3	
16		8297A21H01	3	
17	150VCPW500-3000A-37 kA	8297A19H01	3	
18		8297A22H01	3	
19	150VCPW750-1200A-58 kA	8297A23H01	3	
20		8297A26H01	3	
21		8297A24H01	3	
22		8297A27H01	3	
23	150VCPW750-3000A-58 kA	8297A25H01	3	
24		8297A28H01	3	
25	150VCPW1000-1200A-77 kA	8297A29H01	3	
26		8297A30H01	3	
27	150VCPW1000-3000A-77 kA	8297A31H01	3	
28	1200 Amp. Primary Disconnects (16 Contacts)	508B022G01	6	
29	2000 Amp. Primary Disconnects (20 Contacts)	580B012G01	6	

Line No.	Description	Style No.	Qty.	
30	3000 Amp. Primary Disconnects 20 Contacts	692C037G01	6	
31 32 33	Spring Charging Motor 48V DC 125V DC/120V AC 250V DC/240V AC	699B196G03 699B196G01 699B196G02	1 1 1	
34 35 36	Spring Rel. (Close) Coil 48V DC 125V DC/120V AC 250V DC/240V AC	3759A76G01 3759A76G02 3759A76G03	1 1 1	
38 39 40	Shunt Trip Coil 48V DC 125V DC and 120V AC Cap Trip 250V DC and 240V AC Cap Trip	3759A76G01 3759A76G02 3759A76G03	1 1 1	
41 42 43 44 45	Anti-Pump Y Relay 48V DC 125V DC 250V DC 120V AC 240V AC	3759A74G03 3759A74G04 3759A74G05 3759A74G01 3759A74G02	1 1 1 1 1	
46	Motor Cut-Off Switch Assembly	699B199G01	1	
47	Latch Check Switch	8064A03G01	1	

Line No.	Description	Style No.	Qty.	
48	Auxiliary Switch	698B822H01	1	
49	Fastener Kit (Several of each Item)	8061A01G01	1	
50	Trip D-Shaft	691C380G01	1	
51	Trip Latch (Hatchet)	699B040G01	1	
52	Motor Brushes Kit	8063A77G01	1	
53	Push Rod 150VCPW 500-1200	691C650G01	3	
54	Push Rods All Others	691C651G01	3	

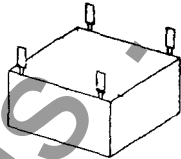
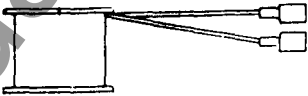
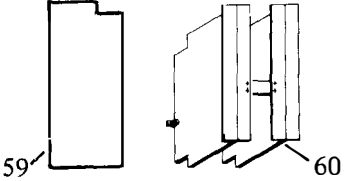
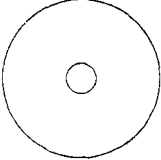
Line No.	Description	Style No.	Qty.	
55	Rectifier (120/240V AC)	3759A79G01	1	
56 57 58	Undervoltage Trip Coil 48 V DC 125 V DC 250 V DC	8064A19G01 8064A19G02 8064A19G03	1 1 1	
59 60	Phase Barrier (4" and 5" VI) Phase Barrier Assembly (7" VI)	691C176H01 691C648G01	2 1	
61	Breaker Wheel	3617A99H01	1	

7.2 ORDERING INSTRUCTIONS

- Always specify breaker rating information and shop order number.
- Describe the item, give style number and specify the quantity desired.
- For electrical components, specify voltage.
- State method of shipment desired.
- Send all orders or correspondence to the nearest Westinghouse sales office.
- See renewal parts data RPD 32-255-1.

7.3 REPLACEMENT OF COMPONENTS

7.3.1 Location of Components

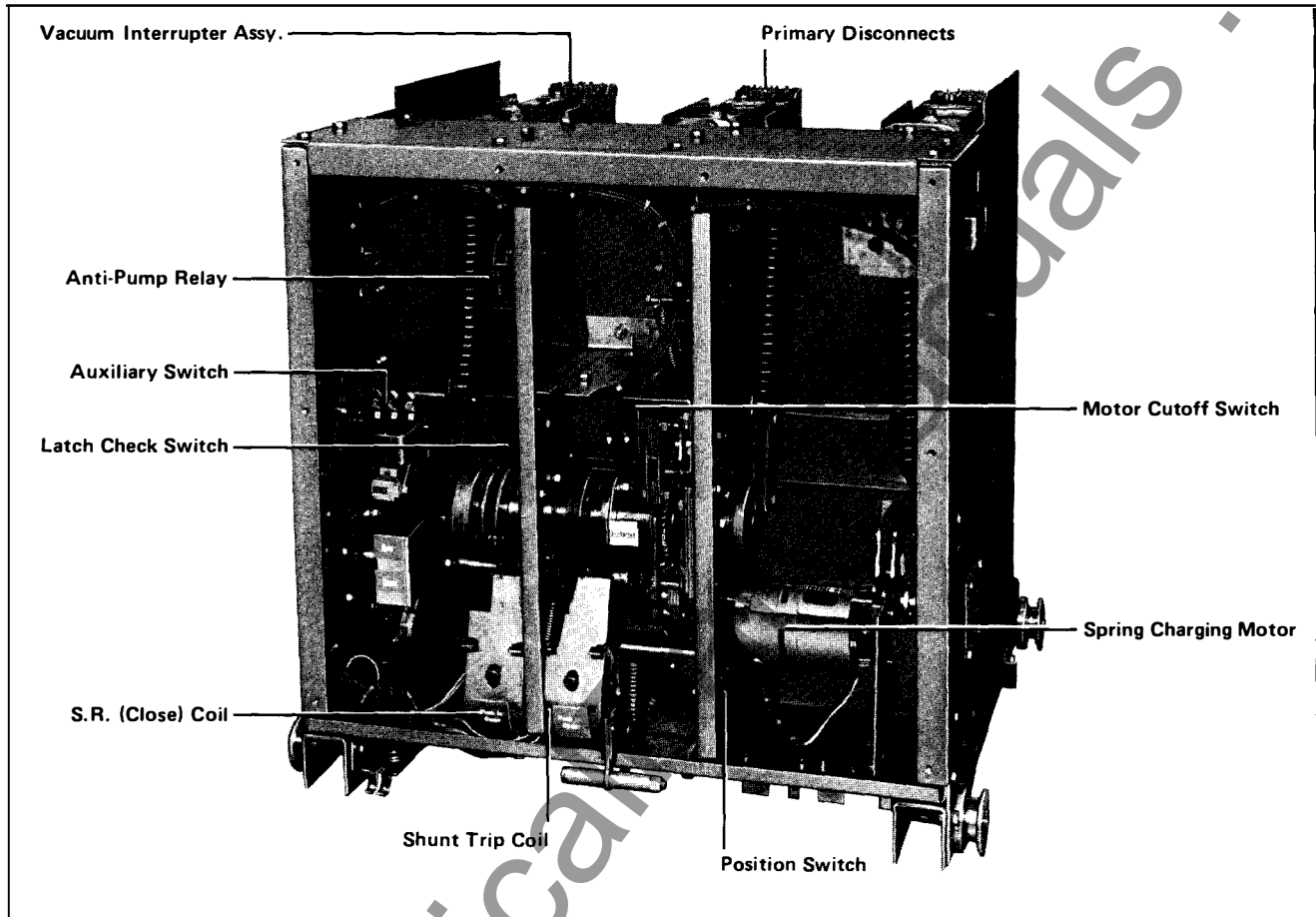

Fig. 7.1

CAUTION: BEFORE ATTEMPTING TO REPLACE ANY COMPONENT, MAKE CERTAIN THAT THE BREAKER IS OPEN, CLOSING SPRINGS DISCHARGED AND CONTROL POWER DISCONNECTED. DISASSEMBLY STEPS ARE SHOWN HERE. FOR ASSEMBLY, FOLLOW THE ORDER IN REVERSE.

7.3.2 Replacement of Vacuum Interrupter Assembly



1. *Tools Required*
Primary Disconnect Plier
Screw Driver, 9/16-1/2"
Offset Box Wrench and
1/2" Swivel Ratchet

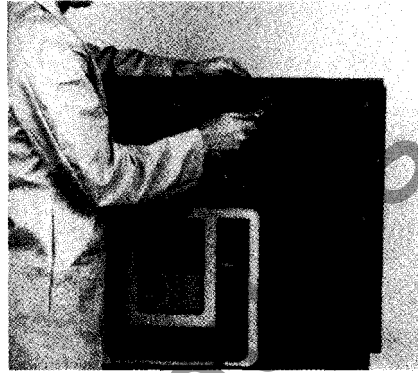

2. *Remove Front Panel*
If Necessary, Remove Barriers

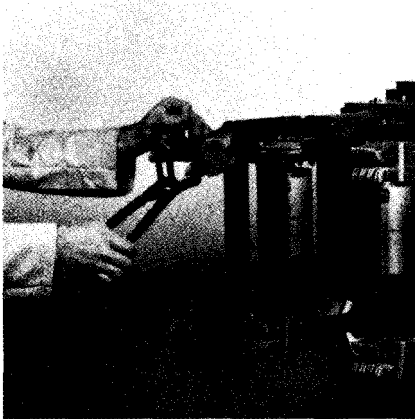

3. *1200/2000 Amps - Remove*
Primary Disconnects

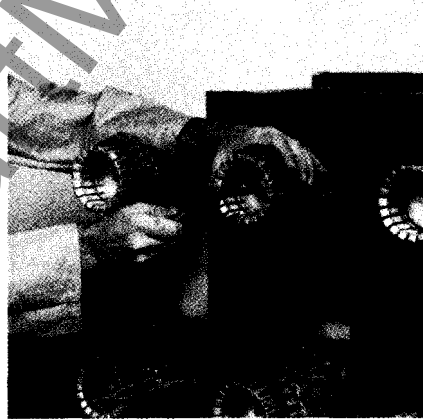

4. *3000 Amps - Remove Primary*
Disconnects



5. *Remove Push Rod Pin To Bell*
Crank Clip

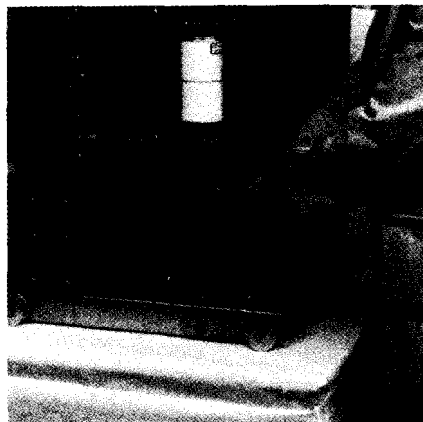

6. *Spread Apart Bell Cranks From Push*
Rod Pin - One At A Time

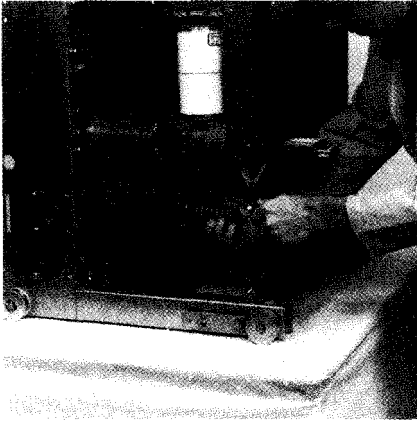

7. Drop Down The Push Rod Assembly Gently



8. Remove The Top Pan



9. Remove The Lower Insulator Mounting Bolts



10. Remove Three Mounting Bolts For The Top Insulator



11. Holding The Interrupter Assembly With One Hand, Remove The Last Mounting Bolt Of The Upper Insulator

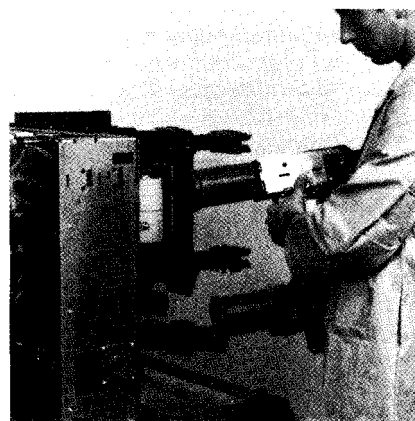

12. Remove The Interrupter Assembly

For installing new interrupter assembly, follow the procedure in reverse. Before tightening the insulator mounting bolts, make certain that the interrupter assembly is square with the rear sheet and in line with the other pole units.

High pot the interrupters for vacuum integrity per Sec. 6.4 before putting in service.

7.3.3 Replacement of Push Rod Assembly

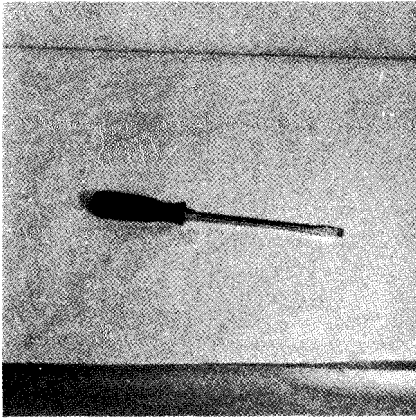

1. Tool Reqd: Screw Driver

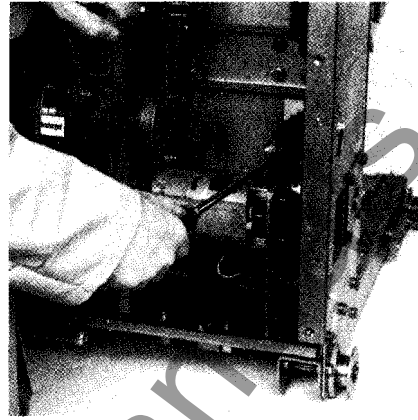

2. Remove The Spring Cup



3. Remove The Pin



4. Remove The Spring Clip Follow Steps 6 & 7 of 7.3.2 and Remove The Push Rod

7.3.4 Replacement of Spring Charging Motor

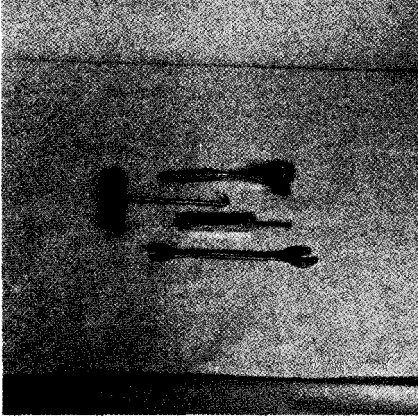

1. *Tools Required:*
 1/2" Socket Wrench, Spring Puller,
 9/64 Allen Key and 3/4" Open End
 Wrench

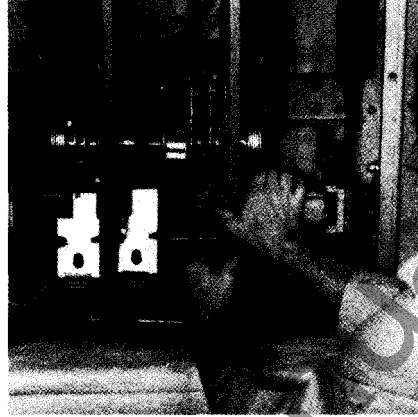

2. *Remove Oscillator Reset Spring*

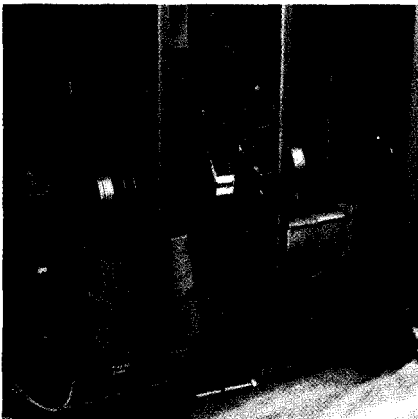

3. *Lift the Oscillator Up To Expose The
 Motor Eccentric*

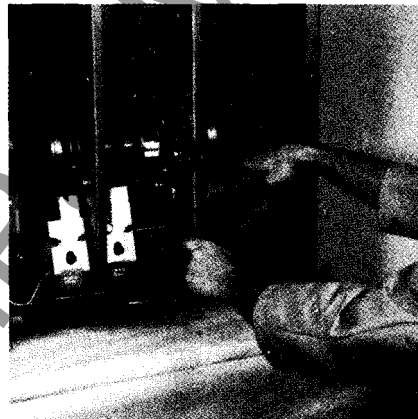

4. *Hold The Motor Commutator With
 One Hand and Turn The Eccentric Clock-
 wise To Unscrew And Remove It*



5. *Disconnect The Motor Terminals*



6. *Remove The Motor Bracket Mounting
 Screws*

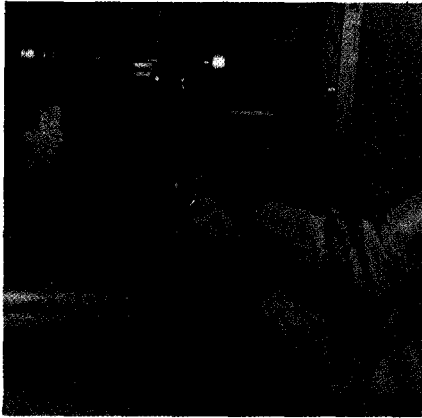

7. Remove The Screws Mounting The Motor To The Bracket

7.3.5 Replacement of Auxiliary Switch Assembly

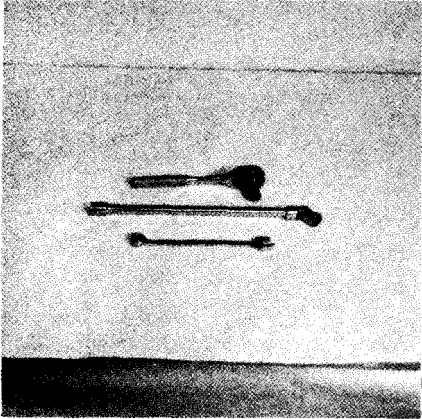

1. Tools Required:
1/2" Swivel Ratchet and 1/2"
9/16" Open Box Wrench



2. Disconnect The Auxiliary Switch Lever From The Hammer

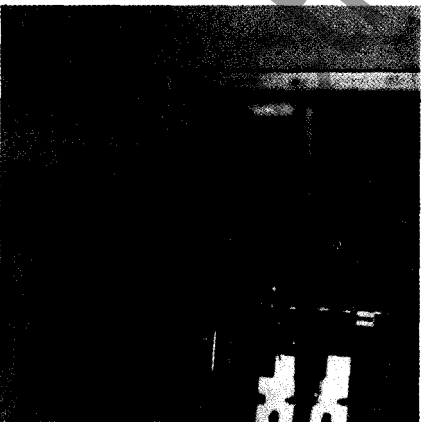

3. Remove Auxiliary Switch Mounting Screws

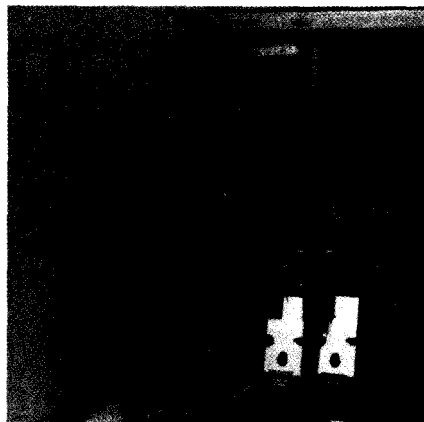

4. Remove Auxiliary Switch Assembly

CAUTION: BEFORE RECONNECTING THE AUXILIARY SWITCH LEVER TO THE HAMMER, MAKE CERTAIN THAT THE OPERATING LINK IS FREE TO OSCILLATE.

7.3.6 Replacement Of Latch Check And Position Switches

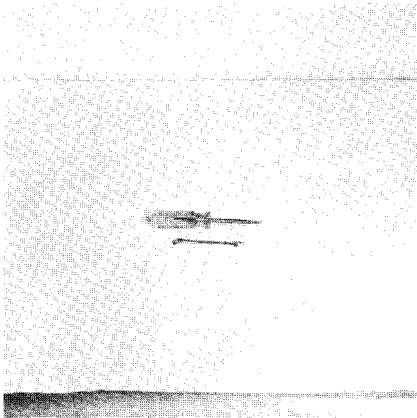

*Tools Required:
A Screw Driver And A 5/16" Wrench*

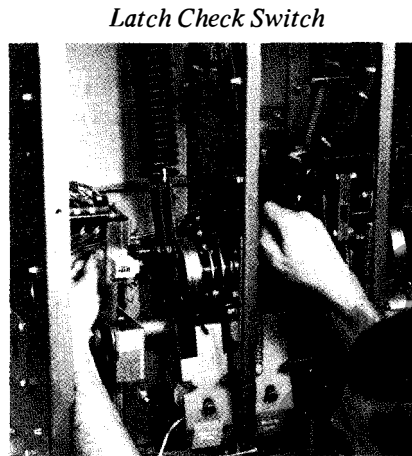

Remove The Mounting Screws And Connections

1. Before installing the new switch, form the switch lever to the approximate contour of the lever of the switch removed.
2. Verify for correct operation as follows:
 - a. Charge closing springs and close the breaker.
 - b. Depress manual push to close button slowly while listening for the snapping sound of latch check switch contacts status change. The switch contacts status must change before the breaker trips open.
 - c. With the breaker open and closing springs charged, lift up the trip "D" shaft lever all the way up to the stop with the help of screw driver. The switch lever shall remain in front of the lever it is pushed by. Check this operation twice.

Position Switch

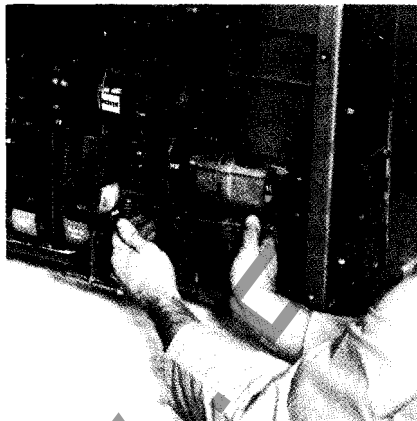

Remove the Position Switch Mounting Screws

1. After installing the new switch, form the switch lever so that
 - a. The switch contacts change on about 1/4" lift of the trip floor tripper and
 - b. There is some over travel of the switch lever with the floor tripper in normal position.

7.3.7 Replacement Of The Spring Release (Close Coil) And Shunt Trip Coil

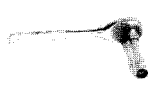

- 1. Tool Required:
1/2" Socket Wrench

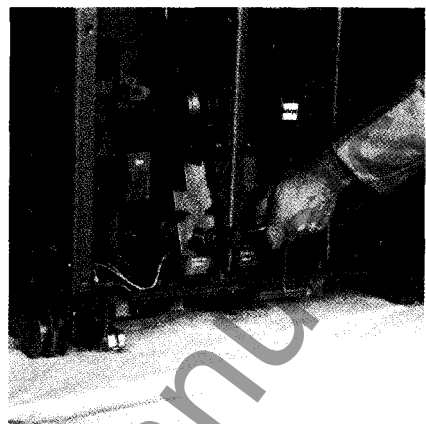

- 2. Remove The Mounting Bolt



- 3. Disconnect Quick Connect Terminals

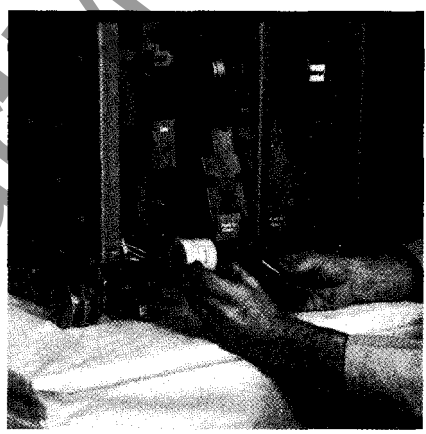

- 4. Remove The Spring Release Coil Along With The Core And Anti-Freeze Washers

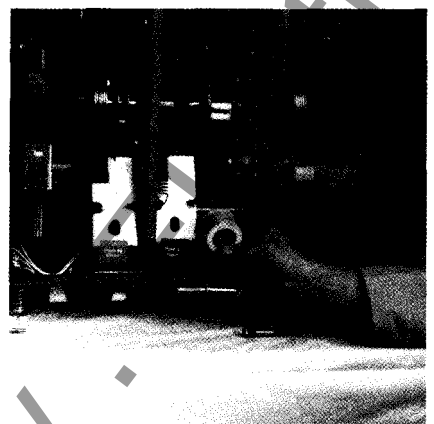

- 5. Remove Shunt Trip Coil Along With The Core And Anti-Freeze Washers

CAUTION:
WHEN REPLACING THE COILS,
MAKE CERTAIN THAT THE
ANTIFREEZE WASHERS ARE
CORRECTLY PLACED IN THE
ASSEMBLY.

7.3.8 Replacement Of The Motor Cut Off Switch

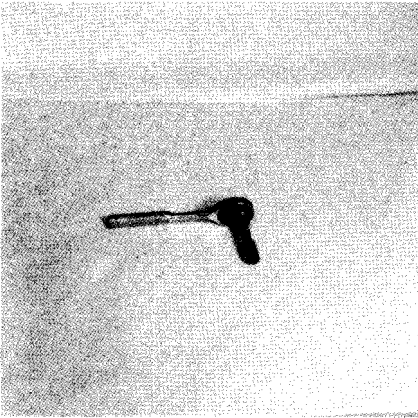

1. *Tool Required*
1/2" Socket Wrench

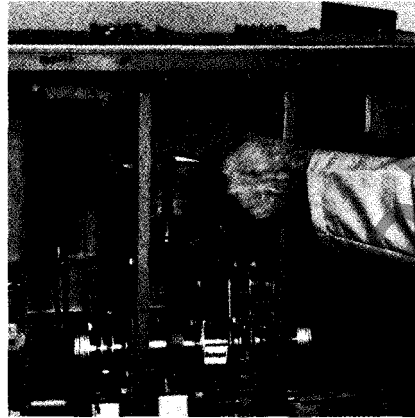

2. *Remove The Mounting Bolts*



3. *Pull Out The Assembly*

After Installing The New Motor Cut Off Switch, Verify For The Correct Operation Of The Switch To Cut Off The Motor At The End Of Charging The Closing Springs. If Necessary, Adjust The Switch Levers.

7.3.9 Replacement Of The Anti-Pump Relay

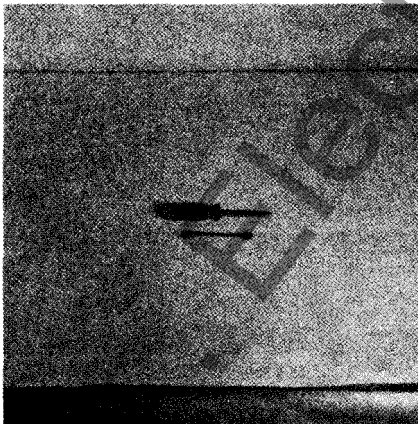

- Tools Required*
A Screw Driver And A 5/16" Wrench

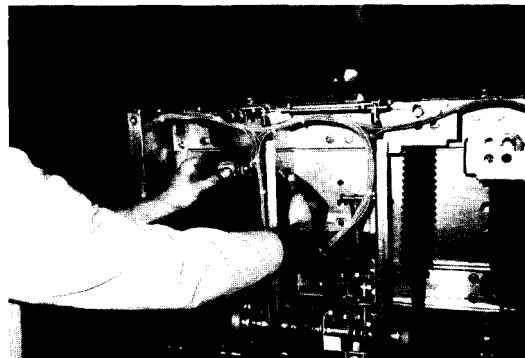

Disconnect The Terminals, Remove The Top Screw And Loosen The Bottom Nut. Remove The Anti-Pump Relay.

APPENDIX

VCP-W Switchgear Instruction Book: I.B. 32-255
VCP-W Descriptive Bulletin: D.B. 32-255
VCP-W Application Data: A.D. 32-255
VCP-W Renewal Parts Data: R.P.D. 32-255

TO OBTAIN THE ABOVE LITERATURE CONTACT:

Westinghouse Electric Corporation
Distribution and Control Business Unit
Electrical Components Division
Pittsburgh, PA 15220

NOTES

www.ElectricalPartManuals.com

NOTES

www.ElectricalPartManuals.com

www.ElectricalPartManuals.com

Westinghouse Electric Corporation
Distribution and Control Business Unit
Electrical Components Division
Pittsburgh, PA 15220