

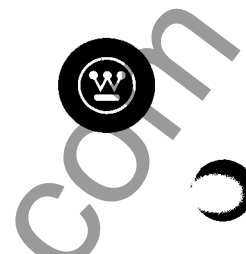

# Westinghouse Type HLE Current Limiting Fuses



WWW



**HLE Applications**

The Type HLE (helical configuration, current limiting) high voltage fuse is a general purpose, indoor or outdoor fuse designed to provide both high and low level fault protection. HLE fuses may be applied wherever it is necessary to limit short circuit currents on high capacity systems.

Because of its general purpose, current limiting characteristics, the HLE fuse is well suited for a wide variety of distribution system and consumer applications. Several of the more frequent possibilities are:

- Power Transformer Protection
- Fused Switches
- Feeder Circuit Sectionalizing

**HLE Description**

Type HLE current limiting fuses, designed for indoor and outdoor applications, are replaceable units with automatic blown fuse indication provided by a striker pin. In addition to giving a local indication of a fuse's condition, the striker pin can be used to trigger an external tripping device. The powerful striker pin delivers approximately 3 joules of energy over a 5/8" travel distance, more than sufficient for mechanical operation of trip-all-phase devices or micro switches. The HLE is adaptable to both disconnect and non-disconnect mounting configurations.

The HLE fuse is a coreless design enclosed in a high strength, filament wound, glass and epoxy tube. It is filled with a high purity silica sand of controlled grain size. Fuse elements are pure silver in a double helix configuration to optimize performance by maximizing the number of elements.

The double helix design delivers:

- Higher Current Ratings
- Cooler Operation
- Improved Time-Current Characteristics
- Reduced I<sup>2</sup>t Let Through
- Shorter Length

Single and double barrel designs are available to cover a wide range of current, voltage and interrupting ratings up to 250E, 15kV and 50kA. For its size, the HLE fuse offers the highest available E-ratings. In addition, HLE 3" diameter fuses directly replace other manufacturers' 12" and 15" clip-centered fuses.

**HLE Advantages**

Type HLE current limiting fuses offer a number of advantages over competing current limiting designs. During the selection process consider the following:

- **Optimized Energy Exchange**  
 The double concentric helix configuration (inner and outer) optimizes energy exchange by making more efficient use of the sand filler.
- **Improved Arc Control**  
 The double helix design has more elements for more surface area permitting better arc control.
- **Lower Temperature Rise**  
 Heat radiation with the HLE design is excellent resulting in lower normal operating temperatures.
- **Promotes Faster Melting**  
 Under overload conditions, thermal transfer from the inner helix is reduced by a modified temperature gradient leading to faster melting.
- **Blown Fuse Indication**  
 A blown fuse striker pin will protrude from the top of the fuse providing a visual identification of operation, as well as a triggering means for external devices.

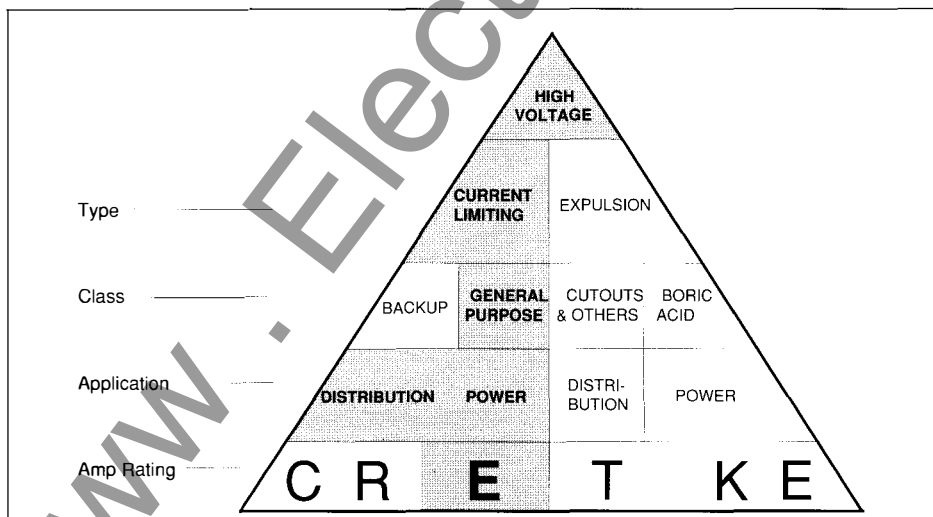

Type HLE High Voltage Fuse Profile

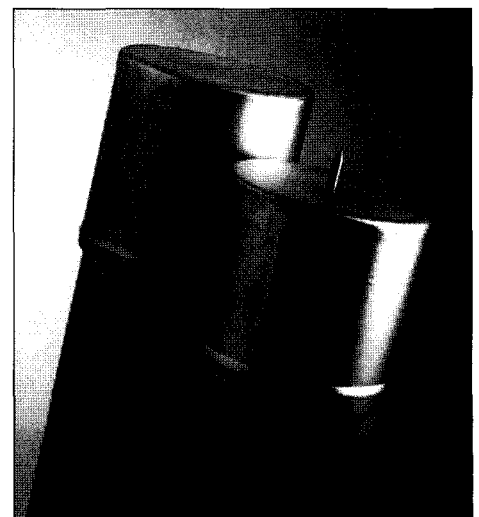

HLE Striker Pin Blown Fuse Indicator



### HLE Advantages

- **Interchangeability**  
HLE fuses are mechanically interchangeable with and have higher current ratings than competing current limiting fuses.
- **Limited Arc Voltage**  
Improved limited arc voltage permits 15.5kV fuses to be used on 8.3kV circuits and 8.3kV fuses to be used on 5.5kV circuits.

HLE fuses also offer additional advantages over other types of fuse designs:

- **Quiet and Safe Operation**  
Type HLE fuses are sealed static units eliminating the need for externally mounted discharge devices.
- **Limits Fault Current**  
By design, the HLE interrupts high fault currents before the first loop of fault current reaches its natural crest value. The double helix design delivers a lower  $I^2t$ .
- **Higher Interrupting Capabilities**  
Type HLE fuses have higher interrupting ratings than expulsion fuses because of their current limiting capabilities.
- **Indoor/Outdoor Application**  
HLE end caps are magneformed to the tube and sealed with RTV sealant.

### Mounting Hardware

Type HLE current limiting fuses are designed to be used in either disconnect or non-disconnect mountings.

All HLE fuse units can be mounted, as supplied, in an appropriate non-disconnect mounting. The addition of disconnect fuse end fittings to the HLE permits the fuse to be mounted in an appropriate disconnect mounting.

Disconnect and non-disconnect live parts above the insulator are available for HLE fuses. Disconnect live parts are supplied with the appropriate fuse end fittings.

### HLE Selection

When a decision has been made to use current limiting fuses, the minimum amount of information required to make the proper selection is:

- Required Voltage Rating
- Required Current Rating
- Required Interrupting Rating
- Required Mounting Method
  - Non-disconnect Mounting
  - Disconnect Mounting
  - Live Parts Only
  - No Required Mounting

Refer to Table 1 for assistance in selecting the correct Type HLE fuse Catalog Number.

HLE fuses commonly provide protection for transformer primaries. There are specific rules governing the selection of the fuse's continuous rating. The Westinghouse High Voltage Fuse User Reference offers suggested minimum current limiting fuse current ratings for self-cooled transformers. The suggested current ratings are intended to be general guidelines only.

Once a fuse catalog number is identified refer to Ordering Guide Supplement 36-609 for pricing.

When selecting the appropriate fuse for a new installation, keep in mind that one fuse and one compatible mounting is required for each phase.

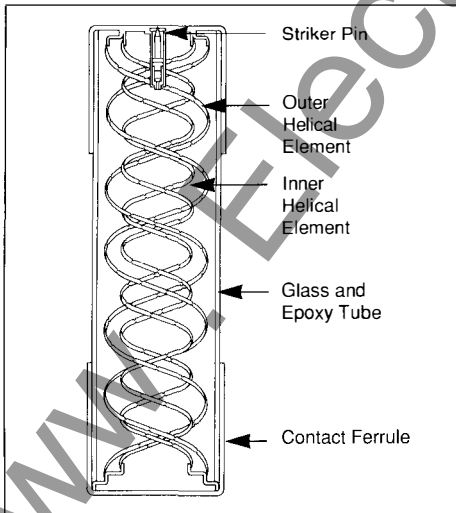

HLE Cross Section Illustrating Double Helix Configuration

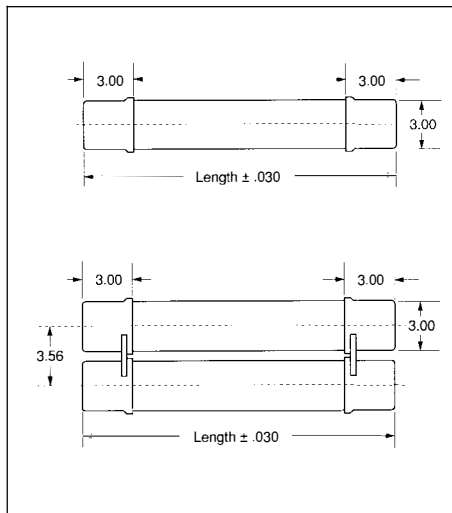

Type HLE Fuse Outline Drawings and Dimensions (inches)

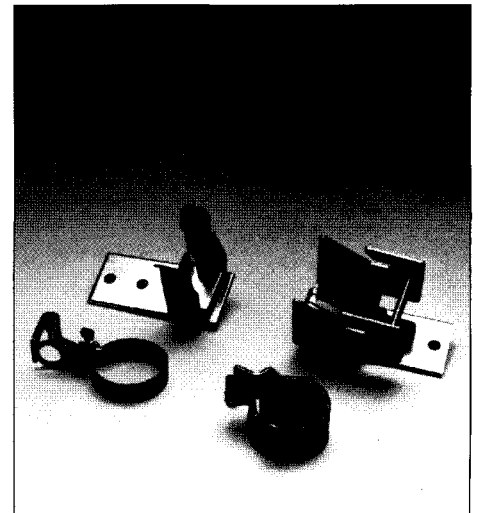

HLE Disconnect Type Live Parts Above Insulator



com

Table 1: HLE Ratings and Selections

Maximum Design Voltage (kV)	Current Rating (Amps)	Catalog Number	Barrel	Interrupting Rating RMS Amps (Sym.)	Diameter (Inches)	Clip Center (Inches)	Length (Inches)	Approx. Shipping Wt. (Lbs.)
5.5 (50/60 Hz)	30	5HLE-30E	Single	63,000	3	12	15.88	8
	40	5HLE-40E	Single	63,000	3	12	15.88	8
	50	5HLE-50E	Single	63,000	3	12	15.88	8
	65	5HLE-65E	Single	63,000	3	12	15.88	8
	80	5HLE-80E	Single	63,000	3	12	15.88	8
	100	5HLE-100E	Single	63,000	3	12	15.88	8
	125E	5HLE-125E	Single	63,000	3	12	15.88	8
	150E	5HLE-150E	Single	63,000	3	12	15.88	8
	175E	5HLE-175E	Single	63,000	3	12	15.88	8
	200E	5HLE-200E	Single	63,000	3	12	15.88	8
	250E	5HLE-250E	Single	63,000	3	12	15.88	8
	300E	5HLE-300E	Double	63,000	3	12	15.88	16.5
	350E	5HLE-350E	Double	63,000	3	12	15.88	16.5
	400E	5HLE-400E	Double	63,000	3	12	15.88	16.5
	450E	5HLE-450E	Double	63,000	3	12	15.88	16.5
	8.3 <sup>①</sup> (50/60 Hz)	20	8HLE-20E	Single	50,000	3	12	15.88
25		8HLE-25E	Single	50,000	3	12	15.88	8
30		8HLE-30E	Single	50,000	3	12	15.88	8
40		8HLE-40E	Single	50,000	3	12	15.88	8
50		8HLE-50E	Single	50,000	3	12	15.88	8
65		8HLE-65E	Single	50,000	3	12	15.88	8
80		8HLE-80E	Single	50,000	3	12	15.88	8
100		8HLE-100E	Single	50,000	3	12	15.88	8
125E		8HLE-125E	Single	50,000	3	12	15.88	8
150E		8HLE-150E	Single	50,000	3	12	15.88	8
180E		8HLE-180E	Single	50,000	3	12	15.88	8
200E		8HLE-200E	Double	50,000	3	12	15.88	16.5
250E		8HLE-250E	Double	50,000	3	12	15.88	16.5
300E		8HLE-300E	Double	50,000	3	12	15.88	16.5
350E		8HLE-350E	Double	50,000	3	12	15.88	16.5
15.5 <sup>②</sup> (50/60 Hz)		20	15HLE-20E	Single	50,000	3	15	18.88
	25	15HLE-25E	Single	50,000	3	15	18.88	9.5
	30	15HLE-30E	Single	50,000	3	15	18.88	9.5
	40	15HLE-40E	Single	50,000	3	15	18.88	9.5
	50	15HLE-50E	Single	50,000	3	15	18.88	9.5
	65	15HLE-65E	Single	50,000	3	15	18.88	9.5
	80	15HLE-80E	Single	50,000	3	15	18.88	9.5
	100	15HLE-100E	Single	50,000	3	15	18.88	9.5
	125E	15HLE-125E	Single	50,000	3	15	18.88	9.5
	150E	15HLE-150E	Double	50,000	3	15	18.88	19.5
	175E	15HLE-175E	Double	50,000	3	15	18.88	19.5
	200E	15HLE-200E	Double	50,000	3	15	18.88	19.5
	250E	15HLE-250E	Double	50,000	3	15	18.88	19.5

① 8.3kV fuses can be used on 5.5kV circuits.

● 15.5kV fuses can be used on 8.3kV circuits.

**Cutler-Hammer**  
Westinghouse &  
Cutler-Hammer Products  
Five Parkway Center  
Pittsburgh, Pennsylvania, U.S.A. 15220

