



INSTRUCTION BOOK

INDUCTION VOLTAGE REGULATORS

Types SI and STI

Westinghouse Electric Corporation

LB. 47-310-2

SPECIAL INQUIRIES

When communicating with Westinghouse regarding the product covered by this Instruction Book, include all data contained on the nameplate attached to the equipment.* Also, to facilitate replies when particular information is desired, be sure to state fully and clearly the problem and attendant conditions.

Address all communications to the nearest Westinghouse representative as listed in the back of this book.

WESTINGHOUSE					
INDUCTION VOLTAGE REGULATOR TYPE SI					
1 PHASE		60 CYCLES		55°C RISE	
KVA CONTINUOUS		IMPULSE TEST LEVEL 60 KV		GALLONS OF LIQUID	
PRIMARY VOLTS	SECONDARY			NET WT WITH LIQUID LBS	
	VOLTS	AMPS	PERCENT		
• 2500	250		± 10	DIAGRAM	
• 2500	125		± 5	INSTRUCTION BOOK	
				SERIAL	

ANY OF THE ABOVE RATINGS MAY BE OBTAINED BY CHANGING BOLTED TERMINAL CONNECTIONS WHICH ARE ACCESSIBLE BY REMOVING THE COVER OF THE REGULATOR. REFER TO THE DIAGRAM OF NUMBER GIVEN ABOVE WHEN MAKING CHANGES IN CONNECTIONS.

POWER

CONTROL
CABINET

WESTINGHOUSE ELECTRIC CORPORATION
NP59906 MADE IN U.S.A.

*For a permanent record, it is suggested that all nameplate data be duplicated and retained in a convenient location.



INSTALLATION • OPERATION • MAINTENANCE
INSTRUCTIONS

**INDUCTION
VOLTAGE REGULATORS**

Types SI and STI

WESTINGHOUSE ELECTRIC CORPORATION
TRANSPORTATION AND GENERATOR DIVISION

EAST PITTSBURGH PLANT

EAST PITTSBURGH, PA.

NEW INFORMATION

EFFECTIVE OCTOBER, 1952

Printed in U.S.A.

INDUCTION VOLTAGE REGULATORS

Types SI and STI

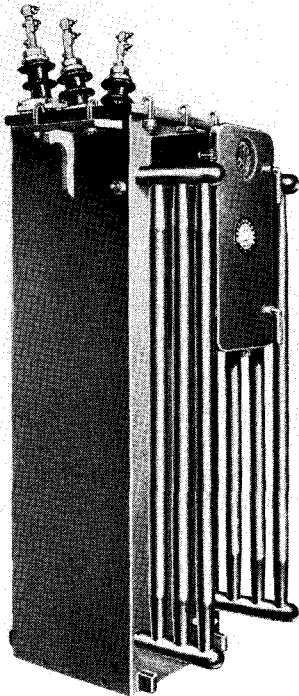

Single-Phase Type SI

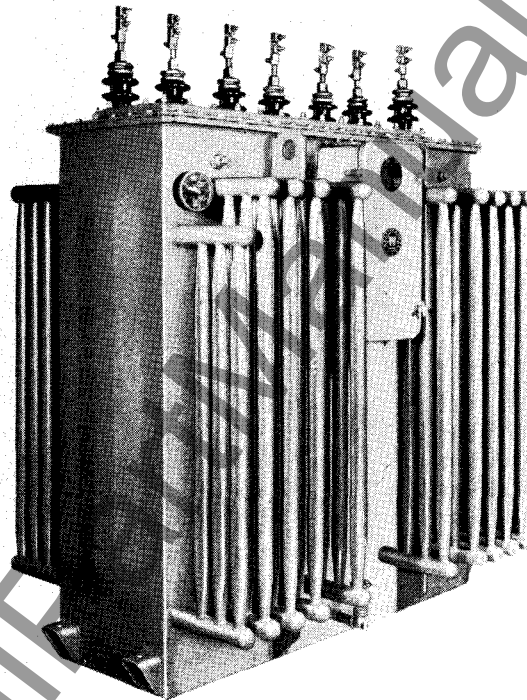

Three-Phase Type STI

This instruction book covers single-phase Type SI machines in the style series 1593 515 to 1593 530; and three-phase Type STI machines not designated by style numbers. Other SI regulators covered by this book are not designated by style number because of special features specified by the purchaser. These machines are designed similar to the ones having style numbers, except for the special features.

The SI line includes standard rated machines from 12.5 kva to 125 kva at 2.5 kv or 5.0 kv. The STI line includes standard rated machines from 112 kva to 300 kva, all at 4.33 kv. All of these regulators are Inerteen-immersed and air-sealed. They are all equipped for outdoor as well as indoor service.

DESCRIPTION

TYPE SI REGULATOR

The SI regulator can be used separately on single-phase feeders or in conjunction with other SI regulators on three-phase feeder applications. This type of three-phase application of single-phase machines is best suited for unbalanced loads because each regulator has its own controls and operates independently of the others.

The main windings of the regulator consist of a primary or shunt winding on the rotor and a

secondary or series winding on the stator. (See Fig. 1). These windings are form-wound of rectangular copper wire and bakelized into solid rigid coils. They are then ground-insulated with a suitable number of turns of insulating wrapper.

There is also a closed-circuit winding on the rotor located 90 degrees from the primary winding. The closed-circuit winding is wound of round enameled wire and the end turns are insulated with cotton tape. The closed-circuit winding equalizes

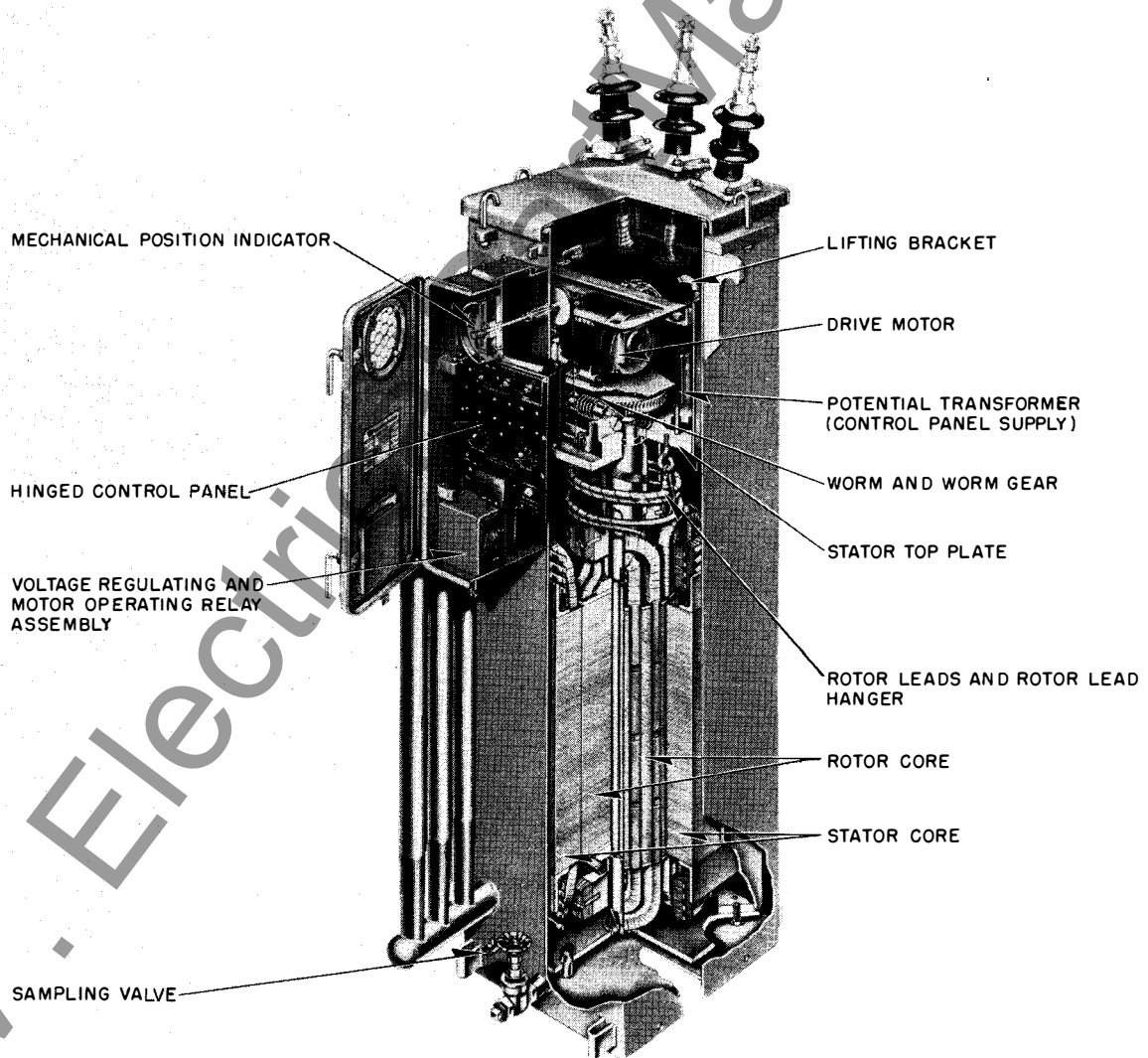

FIG. 1. Cutaway View of Typical Regulator, Type SI

DESCRIPTION

losses and keeps the secondary reactance down, particularly in the neutral position.

In operation, the primary winding is connected across the line, while the secondary winding is connected in series with the line. The voltage induced in the secondary winding (and therefore the amount of voltage that is added to or subtracted from the line) is varied by turning the rotor. All possible values of raise and lower are realized over a rotation of 180 degrees. The rotor is therefore restricted to this amount of travel by limit switches and mechanical stops. The limit switches are located in the control box behind the mechanical position indicator, while the mechanical stops are located on the worm gear.

The operating mechanism consists of a motor-driven gear reduction unit which drives the rotor by means of a solid worm and worm gear arrangement. (See Fig. 1). The worm is cut from a single piece of steel for maximum rigidity in withstanding short-circuit stresses. The worm gear is machined from steel to withstand short-circuit stresses. The worm gear is shrunk on and keyed to the rotor shaft. The motor is a ball-bearing, single-phase, capacitor type. The capacitor and motor are mounted side-by-side on top of the worm housing. External lubrication is unnecessary since the drive motor and gear reduction unit are completely submerged in the Inerteen.

Automatic operation is controlled by a voltage relay which responds to changes in the regulator output voltage. The voltage relay responds to changes in the regulator output voltage and, in turn, operates the secondary relay which operates the motor. The motor moves the regulator rotor in the proper direction to restore the output voltage to its normal value and the voltage relay to its balance position.

A line-drop compensator is inserted between the regulator output voltage (reduced to 125 volts through a potential transformer) and the voltage relay. This compensator allows the voltage to be held constant, within the limits of the machine, at a predetermined distance from the machine.

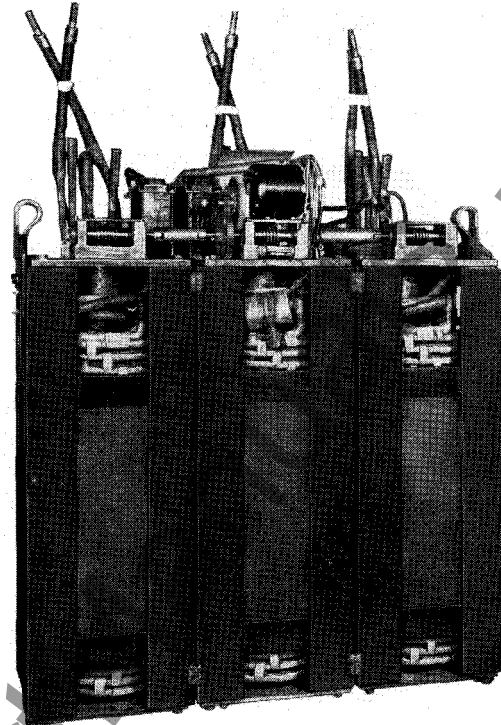

FIG. 2. Typical Triplex Regulator, Type STI
Removed from Tank

TYPE STI REGULATOR

The three-phase, Type STI regulator consists of three SI machines fabricated into a single unit (Fig. 2) and placed in a single large tank. The drive mechanisms are all coupled together so that each phase receives the same amount of voltage increase or decrease. The STI regulator has essentially the same automatic control and drive mechanism as the SI regulator. The control is energized by one phase of the regulated three-phase feeder.

Type STI regulators are best suited for use on three-phase lines with balanced loads.

RECEIVING, HANDLING AND STORING

When received, the regulator should be carefully inspected for possible damage in transit. Notify the carrier immediately if any damage is found due to transportation. The following points should be checked:

1. At room temperature or approximately 25 degrees C, the Inerteen level should reach the 25-degree C mark on the liquid level gauge.
2. Types SI and STI regulators are Inerteen-filled under vacuum, sealed and pressure-tested at the

factory. If inspection indicates that the seal may have been disturbed in transit, pressure-test the tank and test the Inerteen for dielectric strength. The Inerteen should test at least 22 kv using a 1/10-inch test gap. The tank should maintain an applied internal pressure of 5 pounds per square inch without appreciable drop over a six-hour period.

3. The relays and control panel (see Fig. 3) should be checked for proper operation. (Refer to "Control Panel and Relay Operation, Tests and Adjustments", pages 9 to 11, for procedure to be followed).

HANDLING

The regulators are shipped bolted to wooden skids long enough to provide stability in moving. They may be moved on these skids, or if a crane is available, by means of the lifting hooks welded to the sides of the tank. When using a crane, check the weight of the machine as indicated on the nameplate, against the capacity of the crane. The machines may also be moved short distances on metal rollers or a heavy dolly.

STORING

When stored for a considerable length of time, the regulators should be placed indoors, if possible, and preferably in a location that is dry and free from large temperature variations. Such variations are conducive to the condensation of moisture in machines when in storage. After SI or STI regulators have been stored for a considerable time, the

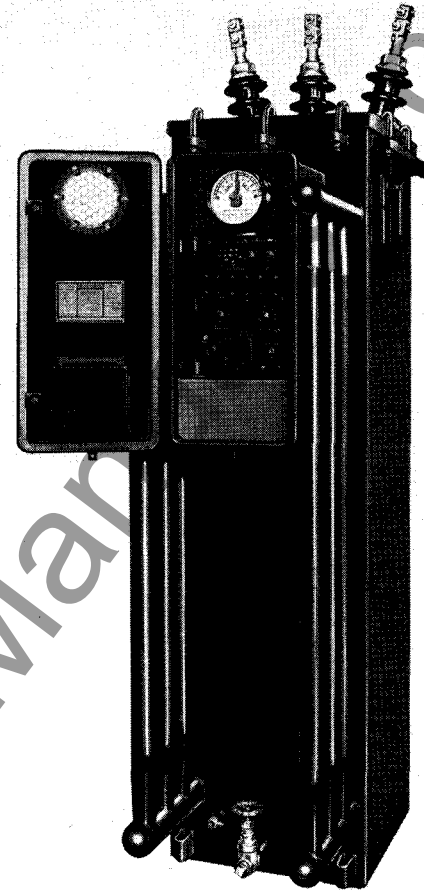

FIG. 3. Type SI Regulator with Control Cabinet Open Showing Controls

Inerteen should be tested for dielectric strength at 22 kv for a 1/10-inch test gap.

INSTALLATION

1. Types SI and STI regulators may be connected either to a de-energized feeder or to a live feeder without interruption of service, if proper precautions are taken. In either case, the following points should be checked first:

a. Make sure that the machine is suitable for the feeder which it is to control by checking the nameplate rating. Feeder voltage regulators having equal raise and lower ranges of regulation (not in excess of 10 percent raise and 10 percent lower) are capable of operating without exceeding the specified temperature rise provided the rated load current is not exceeded, and the input and output voltages are within the limits designated by NEMA. (See Table No. 14, "EEL-NEMA Preferred Voltage Ratings for A-C Systems and Equipment", NEMA

Publication No. 117, dated May 1949 or subsequent revision).

b. Check the diagram sent with the regulator for special connections which may be slightly different from the typical diagrams shown in Figs. 12 and 13.

c. Make sure that the control supply switch is "off" and the automatic-manual switch is on "manual".

d. Make sure that the machine is in the "neutral" position as indicated by the mechanical position indicator. Type STI triplex machines have only one position indicator since the three single-phase units are coupled together.

INSTALLATION

e. After a regulator is installed and before it is actually placed in service, inspect it for possible damage in transit or handling. If the seal appears to have been disturbed, pressure-test the machine and dielectric-test the Inerteen as outlined under "Receiving, Handling and Storing", page 4.

2. If the machine is to be connected to a de-energized feeder, the sequence of connections is immaterial. If the machine is being connected to a live feeder, the connections must be made in the sequence indicated below for each type of machine after checking the above points.

a. To connect a Type SI regulator to a live line:

1. Connect the primary or exciting winding across the line.
2. Connect the secondary or series winding into the line in parallel with a by-pass switch.
3. Open the by-pass switch to place the regulator in service.
4. The control supply switch may now be placed in the "on" position and the controls checked as outlined under "Control Panel and Relay Operation, Tests and Adjustments", pages 9 to 11.

b. To remove a Type SI regulator from a feeder without interrupting service:

1. Run the regulator to the "neutral" position by hand control.
2. Turn the control supply switch "off".
3. By-pass the secondary winding.
4. Open the secondary circuit by disconnecting the number 8 bushing (see Fig. 12).
5. Disconnect the regulator (bushings number 1 and 4) from the line.

c. When installing a Type STI regulator without interrupting service:

1. Make certain that the machine is in the "neutral" position, the automatic-manual switch on "manual" and the control supply switch "off".
2. If the machine is wye-connected, it will have a neutral bushing (S_0L_0 in Fig. 13). If the machine is being connected to a four-wire, three-phase line, connect the neutral bushing to the fourth wire. If the machine is being connected to a three-phase, three-wire ungrounded circuit, connect the neutral bushing to ground through a lightning arrester.
3. Insert a by-pass switch in each line.
4. Connect each primary bushing (S_1 , S_2 and S_3 in Fig. 13) to the power side of one of the by-pass switches.

5. Connect each secondary bushing (L_1 , L_2 and L_3 in Fig. 13) to the load side of one of the by-pass switches so that S_1 and L_1 are across one by-pass switch, S_2 and L_2 across the second, and S_3 and L_3 across the third.

6. Open the by-pass switches to place the machine in service.

7. Check the controls as outlined under "Control Panel and Relay Operation, Tests and Adjustments", pages 9 to 11.

d. To remove a Type STI regulator from a line without interrupting service:

1. Run the regulator to the "neutral" position by hand control, with the automatic-manual switch in the "manual" position.
2. Turn the control supply switch "off".
3. By-pass the secondary windings by means of a by-pass switch inserted in each line between S_1 and L_1 , S_2 and L_2 , and S_3 and L_3 .
4. Disconnect the secondaries by opening the connections of L_1 , L_2 and L_3 to the line.
5. Disconnect the primaries by opening the connections of S_1 , S_2 and S_3 to the line.
6. Disconnect the neutral bushing (S_0L_0) from the fourth wire if such a connection exists by virtue of the type of machine and feeder (delta-connected machines have no neutral bushing).

Important. The primary of an induction regulator should not be disconnected while the secondary is in the line and carrying load current, as a high voltage may be induced in the windings.

All three phases of a Type STI regulator must be connected to the line before the machine will operate properly.

CONNECTIONS

Changes in the series-parallel arrangement of the primary or secondary windings are made by removing the tank cover to provide accessibility to the leads. The cover is removed by removing the bronze bushing caps and terminals, loosening the J-bolts and then raising the cover assembly complete with procelains.

The actual change is made by means of bolted connections. The rotor and stator leads terminate in flat terminals drilled so that they can be bolted together as required and marked as indicated on the wiring diagram to facilitate the changing of connections. When changing the primary connections of a 5-kv machine, the primary leads of the motor-operating transformer and the secondary tap

of the control potential transformer must be changed also in accordance with the regulator wiring diagram. Unless otherwise specified, regulators are shipped connected in series and the nameplates marked accordingly.

GROUNDING, LIGHTNING PROTECTION AND SHORT-CIRCUIT PROTECTION

Types SI and STI regulators are provided with a copper grounding pad on the rear tank wall near the base. The pad has two $\frac{1}{2}$ -13 bolt-holes on $\frac{13}{4}$ -inch centers. The cross section of the grounding conductor should be at least equal to that of the maximum size cable that connects the regulator to the line. The control circuits have a single common ground located in the control cabinet behind the control panel.

For the best protection against voltage surges, lightning arresters should be mounted as close to

the regulator as possible. An arrester should be connected to each terminal and grounded directly to the regulator tank. For single-phase applications it is recommended that 3-kv arresters be used on 2.5-kv machines, and 6-kv arresters be used on 5-kv machines. For three-phase applications on grounded systems, the rating should be above the largest possible fault voltage. Three-phase, wye-connected machines which are used on four-wire circuits do not require an arrester on the neutral bushing since the fourth wire is grounded.

The regulator's impedance is too low to provide adequate protection against short-circuit currents. It is therefore recommended that reactors be provided between the source of power and the regulators. The reactance should be large enough to limit the short-circuit current through the regulator to not more than 25 times rated full-load current. Induction voltage regulators are designed to withstand 25 times full load current for two seconds without damage.

OPERATION

OPERATION OF MOTOR FROM AN EXTERNAL SOURCE OF POWER

When the regulator is de-energized, the motor may be operated from an external source of power. The connections for such operations are as follows:

1. Remove the *ungrounded* secondary lead of the motor-operating transformer from the upper terminal block. This is lead X-3 in Figs. 12 and 13. *However, the lead designation may be different on a given machine due to special features. The correct designation for this lead should be obtained from the wiring diagram supplied with the regulator.* The transformer lead is always connected to the top position of the terminal block as indicated in Figs. 12 and 13. Failure to remove this lead will tend to excite the regulator through the motor-operating transformer and eventually overheat the transformer.

2. If the external 240-volt source of power is ungrounded, it may now be connected directly between ground and the terminal block post from which the transformer lead was removed. (G and X-3 in Figs. 12 and 13). If the external power source is grounded, the ground connection to "G" should be removed first.

3. Before applying power to the circuit, make sure that the automatic-manual switch is in the "manual" position; otherwise, the machine will run to the maximum position as soon as the power is applied.

After applying the power and turning the control supply switch "on", the motor may be operated by means of the manual raise-lower knob on the panel.

DESCRIPTION OF CONTROLS

The controls of SI and STI regulators consist of two groups. One group is located in the tank submerged in the Inerteen and the other is located in the dust-proof control cabinet.

The tank group includes two potential transformers, two current transformers, the motor and capacitor.

The motor-operating transformer provides the drive motor with 250-volt source of power while the output potential transformer provides the control circuits with a 125 nominal voltage proportional to the output voltage.

One current transformer provides 0.29 ampere to the line-drop compensator at full load while the other is used to measure load current.

OPERATION

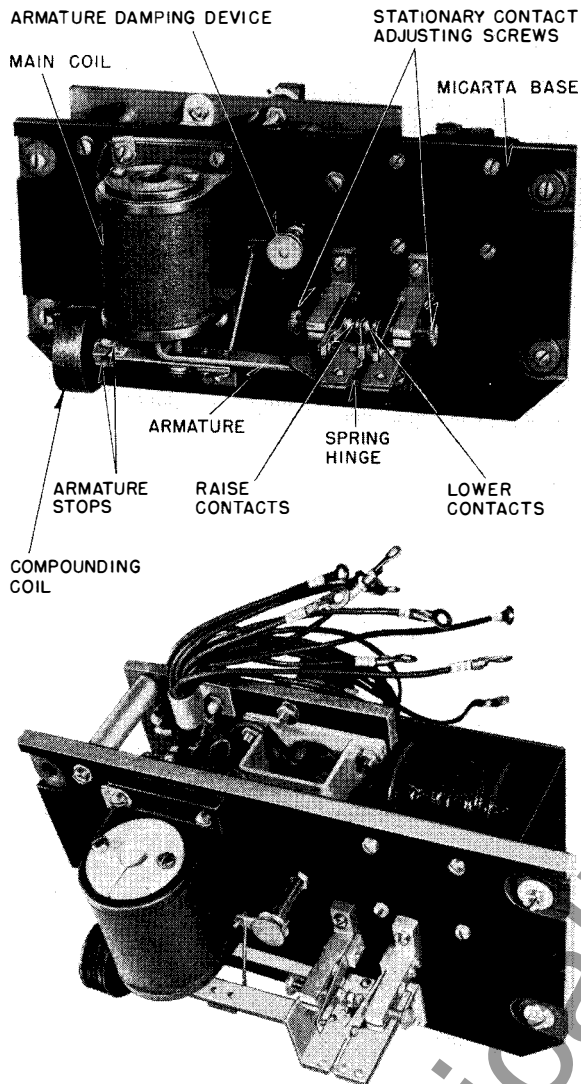

FIG. 4. Front View of Typical Voltage-Regulating Relay Assemblies

The motor and starting capacitor are mounted side by side on top of the worm housing. (See Fig. 1). The motor is specially designed to develop a high starting torque. It is a reversible, single-phase, ball bearing motor.

The control supply switch, automatic-manual switch, manual raise-lower switch, output voltage terminals, line-drop compensator, sensitivity adjustment, and balance volts adjustment are all mounted on the hinged control panel in the control cabinet. (See Figs. 1 and 6).

Above the control panel are located the mechanical position indicator (Fig. 1) with drag hands and reset knob, the limit switches behind the position

indicator and the load current measuring terminals. A copper shorting jumper is located across the load current measuring terminals. The terminals consist of a double knob arrangement to allow the ammeter to be connected before the jumper is removed.

Below the control panel is located the voltage-regulating and motor-operating relay assembly. (See Figs. 1, 4 and 5). The main coil of the voltage-regulating relay (Fig. 4) is energized by the output voltage modified by the uncompensated volts setting and the line-drop compensator setting. The line-drop compensator setting is, in turn, modified by the phase-angle selector screw setting.

The compounding coil of the voltage-regulating relay (Fig. 4) is energized through the sensitivity adjustment. This provides an adjustable pull on the magnetic tip of the armature.

The left-hand contacts of the voltage-regulating relay run the regulator in the "raise" direction while the right-hand contacts run the regulator in the "lower" direction. (See Fig. 4).

The armature damping device and the stationary contact's leaf springs prevent bouncing of the voltage-regulating relay contacts.

All of the relays are spring-hinged to eliminate the need of pivots. This prevents sticking or binding of relay armatures.

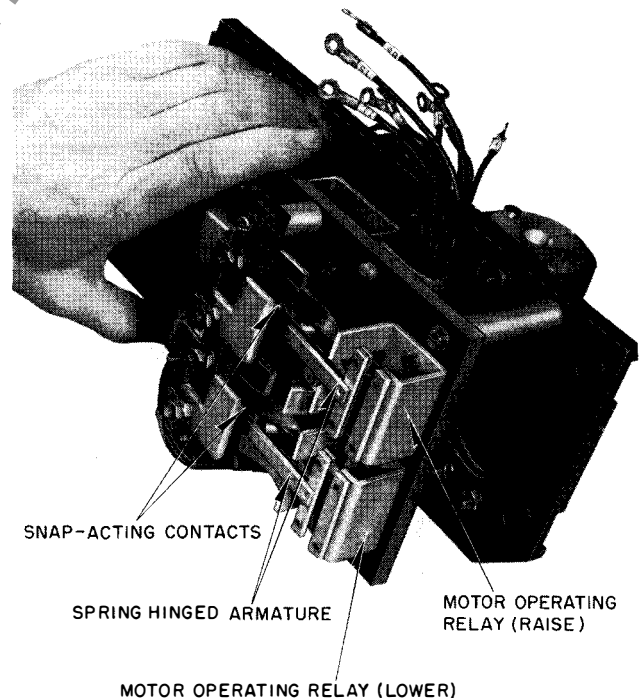

FIG. 5. Rear View of Voltage-Regulating Relay Assembly Showing Motor-Operating Relays

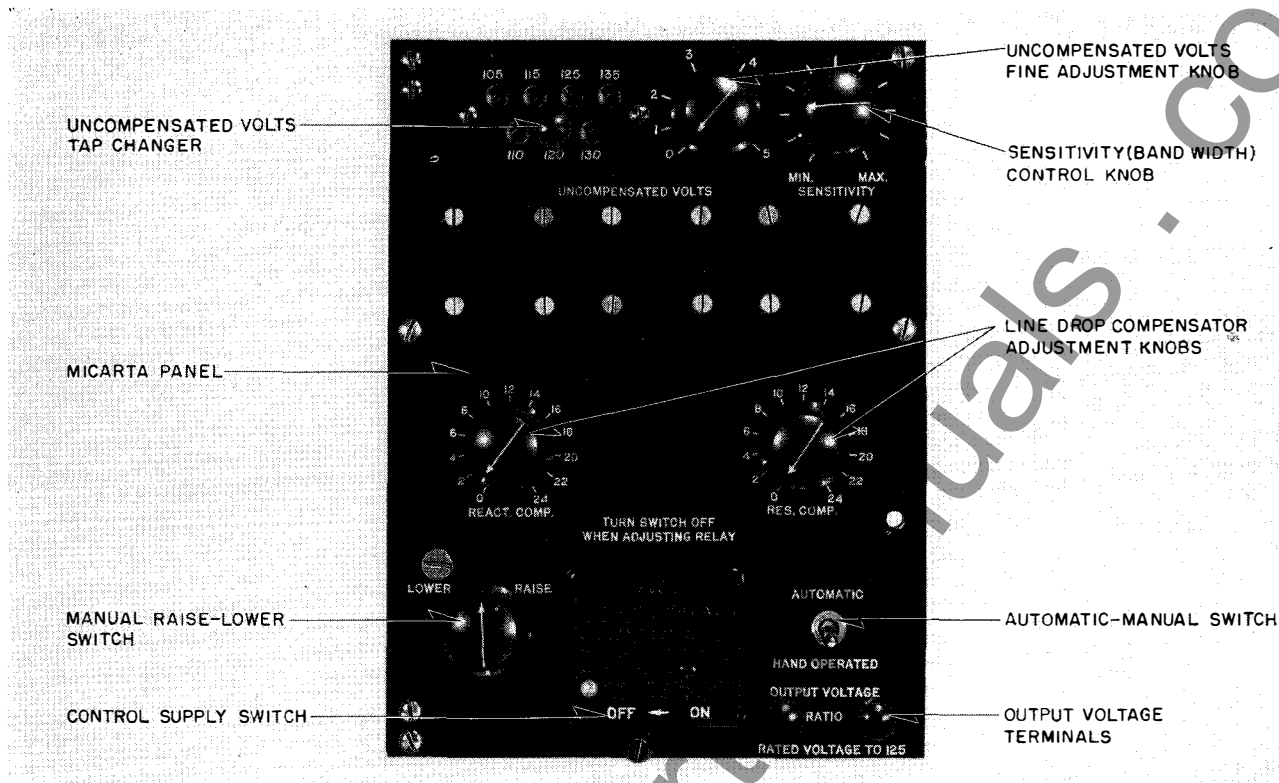

FIG. 6. Front View of Control Panel

CONTROL PANEL AND RELAY OPERATION

Control Supply Switch. (See Fig. 6). This Sentinel type switch provides power to the control panel from the motor-operating and potential transformers. It contains an overload thermal element in series with the motor-operating circuit. This element operates to open both the motor-operating circuit and the potential transformer circuit. In addition there is a fuse not integral with the switch but located in the potential transformer circuit to protect the control circuits.

Automatic-Manual Switch. This switch, when in the "manual" position, prevents automatic operation under control of the voltage-regulating relay. In the "automatic" position, this switch permits both automatic and manual operation in order to simplify the sensitivity adjustment. (Refer to "Control Panel and Relay Tests and Adjustments", page 10).

Manual Raise-Lower Switch. When the automatic-manual switch is in the "manual" position, and the control supply switch is "on", turning the raise-lower switch to the right causes the regulator

to run toward the maximum "raise" position and turning it to the left causes the regulator to run toward the maximum "lower" position. The movements of the regulator can be observed on the mechanical position indicator.

Uncompensated Volts. This adjustment is used to set the voltage level at which the voltage regulating relay balances without any effect from line-drop compensation. The ratio of the potential transformer is such that when this adjustment is set at 125, the machine will maintain the line at full rated voltage. In other words, an uncompensated volts adjustment of 125 for the voltage-regulating relay corresponds to the full rated voltage of the machine. The actual adjustment is made by means of a tap changing plug for large increments of 5 volts and a calibrated knob for smaller increments from 0 to 5 volts. The tap changing plug should be set for the nearest 5 volt step below the desired voltage level. The calibrated knob is then set to indicate the increase of the desired voltage level over the voltage setting of the tap changer plug. The uncompensated volts setting is then the sum of the tap changing plug setting and the calibrated knob setting.

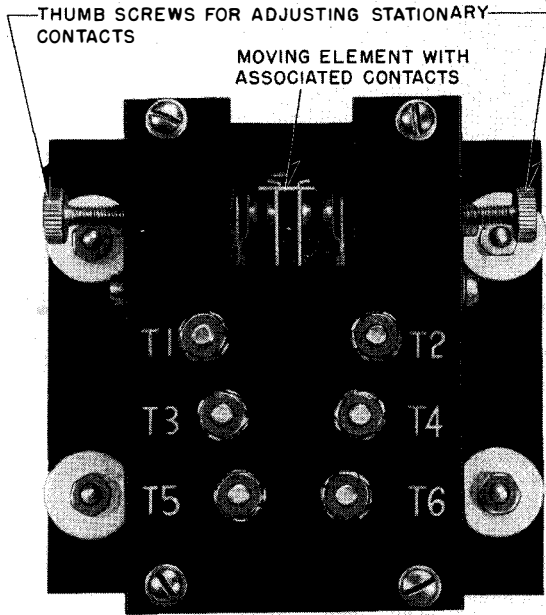

FIG. 7. Time Delay Relay

Compensation Adjusting Knobs. These knobs are used to provide compensation for the varying resistance and reactance line drop between the regulator and the load center where the voltage is to be maintained constant. When the voltage is to be held constant at the regulator, these knobs are set at zero. (See "Line-Drop Compensator Settings", page 11, for procedure in making settings).

Sensitivity. This knob is used to adjust the regulation band width. (See "Control Panel and Relay Tests and Adjustments" in next column.

Phase Angle Selector. (Located on back of panel). The connections of this three-position switch are changed by changing the position of the screw and washer which acts to complete the circuits. The function of the phase angle selector is to compensate for the phase shift between the current and voltage transformer inputs to the control panel when the regulators are connected in delta. For single-phase operation of Type SI machines, the screw should be in the center position. See the machine wiring diagram or Fig. 12 for the correct position of this screw on Type SI machines being used on three-phase applications. Wye-connected Type STI machines do not require a phase shift, therefore, in this case the selector screw is in the center position. On delta-connected

Type STI machines, the selector screw will be in either the left-hand or right-hand position depending on the phase rotation of the line.

Time Delay Relay. (See Fig. 7). This relay is not standard equipment on Type SI or STI regulators, however, many machines are supplied with it when specified. This relay provides up to 20 seconds time delay between the closing of the voltage-regulating relay contacts and the operation of the regulator. The regulator will respond only if the voltage-regulating relay contacts are closed for a period corresponding to the delay period. Thus the regulator does not respond to every self-correcting voltage fluctuation but rather to voltage shifts of time delay duration or more. This eliminates unnecessary regulator operations and extends the life of the mechanical parts. The relay operates on the thermal element principle. It has two moving contacts mounted on separate bimetallic straps. When a voltage-regulating relay contact closes, the corresponding bimetallic strap is heated until the operating contact touches its stationary contact. This energizes the motor-operating relay causing the regulator to operate in its usual manner. The two bimetallic straps are tied together to prevent both from making contact at the same time. The stationary contacts are adjustable by means of knurled thumb-screws. (See Fig. 7). The adjustment of the stationary contacts determines the duration of time delay.

Time Delay Switch. When in the "off" position, this switch eliminates the time delay, causing the regulator to respond instantly to an unbalance of the voltage-regulating relay. The same result may be obtained by adjusting the knurled thumb-screws of the time delay relay for zero time delay by bringing the stationary contacts into continuous contact with the moving element.

CONTROL PANEL AND RELAY TESTS AND ADJUSTMENTS

When testing or adjusting the regulator controls, a portable voltmeter must be used to read the output voltage. Connect the voltmeter to the output voltage testing terminals to read the regulated voltage. A reading of 125 volts on the meter corresponds to the rated voltage of the machine. Set the uncompensated volts adjustment for the desired voltage level as outlined under "Control Panel and Relay Operation" on page 9. With the automatic-manual switch on "automatic" and the compensation adjusting knobs on "zero", turning the control supply switch "on" will cause

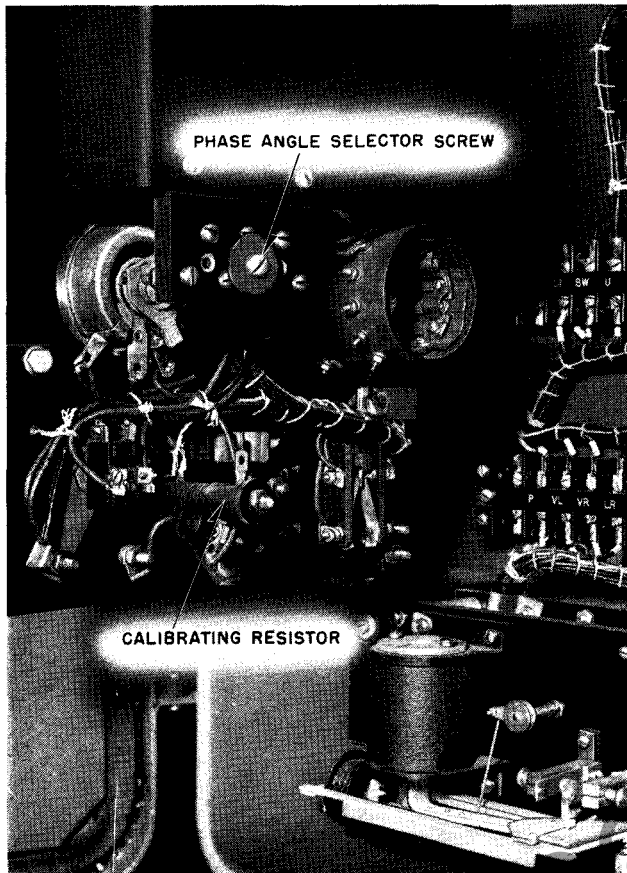

FIG. 8. Rear View of Control Panel

the machine to operate until the reading of the voltmeter agrees with the uncompensated volts setting. The machine may now be operated in small steps by means of the manual raise-lower switch to change the output voltage to a point where the voltage relay will make contact causing the regulator to operate automatically to bring the voltage back to a balance value. Operating the regulator both "raise" and "lower" in this manner and reading the voltage on the portable voltmeter at which the regulator operates will determine the sensitivity or band width. With the sensitivity knob in the "maximum" position, a band width of approximately 1 volt is obtained (uncompensated volts setting $\pm 1/2$ volt). With this knob in the "minimum" position, a band width of 4 or more volts is obtained (uncompensated volts ± 2 volts).

After several hours of continuous operation, the adjustment of the calibrating resistor on the back of the panel may be checked by observing that the uncompensated volts setting agrees with the voltmeter reading when the voltage relay is in the balance position. Adjustment of the calibrating

resistor (Fig. 8) is made at the factory with the phase angle selector screw in the center position. No further adjustments of this calibrating resistor should be necessary unless the phase angle selector screw is moved to another position.

The voltage-regulating relay and the motor-operating relays are adjusted at the factory and should require no further adjustments. The contacts on these relays are silver and, therefore, do not require dressing or polishing. After a long period of time, the contact spacing on the voltage-regulating relay may need adjusting to compensate for wear. Approximate adjustment of these contacts should give a condition where the moving contact just touches a stationary contact when the balance arm tip is half-way between the holding magnet tip and the corresponding stop. Final adjustment of the contact spacing should be such that the regulator will restore the voltage on either raising or lowering to the center of the band. Increasing the contact spacing causes the voltage to be corrected further after contact is made, and decreasing the spacing causes it to be corrected less.

LINE-DROP COMPENSATOR SETTINGS

Correct settings of the line-drop compensator can be obtained by means of the formulas given on page 13. These settings can later be modified if

TABLE NO. 1

SIZE OF CONDUCTOR			R = 60-CYCLE, A-C RESISTANCE IN OHMS PER CONDUCTOR PER MILE AT 50°C.
Circular Mils	AWG	Strands	
1,000,000	—	61	0.0685
900,000	—	61	0.0752
800,000	—	61	0.0837
750,000	—	61	0.0888
700,000	—	61	0.0947
600,000	—	37	0.109
500,000	—	37	0.130
400,000	—	19	0.162
300,000	—	19	0.215
250,000	—	19	0.257
211,600	0000	7	0.303
167,806	000	7	0.382
133,077	00	7	0.481
105,535	0	7	0.607
83,690	1	1	0.749
66,370	2	1	0.945
52,630	3	1	1.192
41,740	4	1	1.503
33,100	5	1	1.895
26,250	6	1	2.390
20,820	7	1	3.014
16,510	8	1	3.800

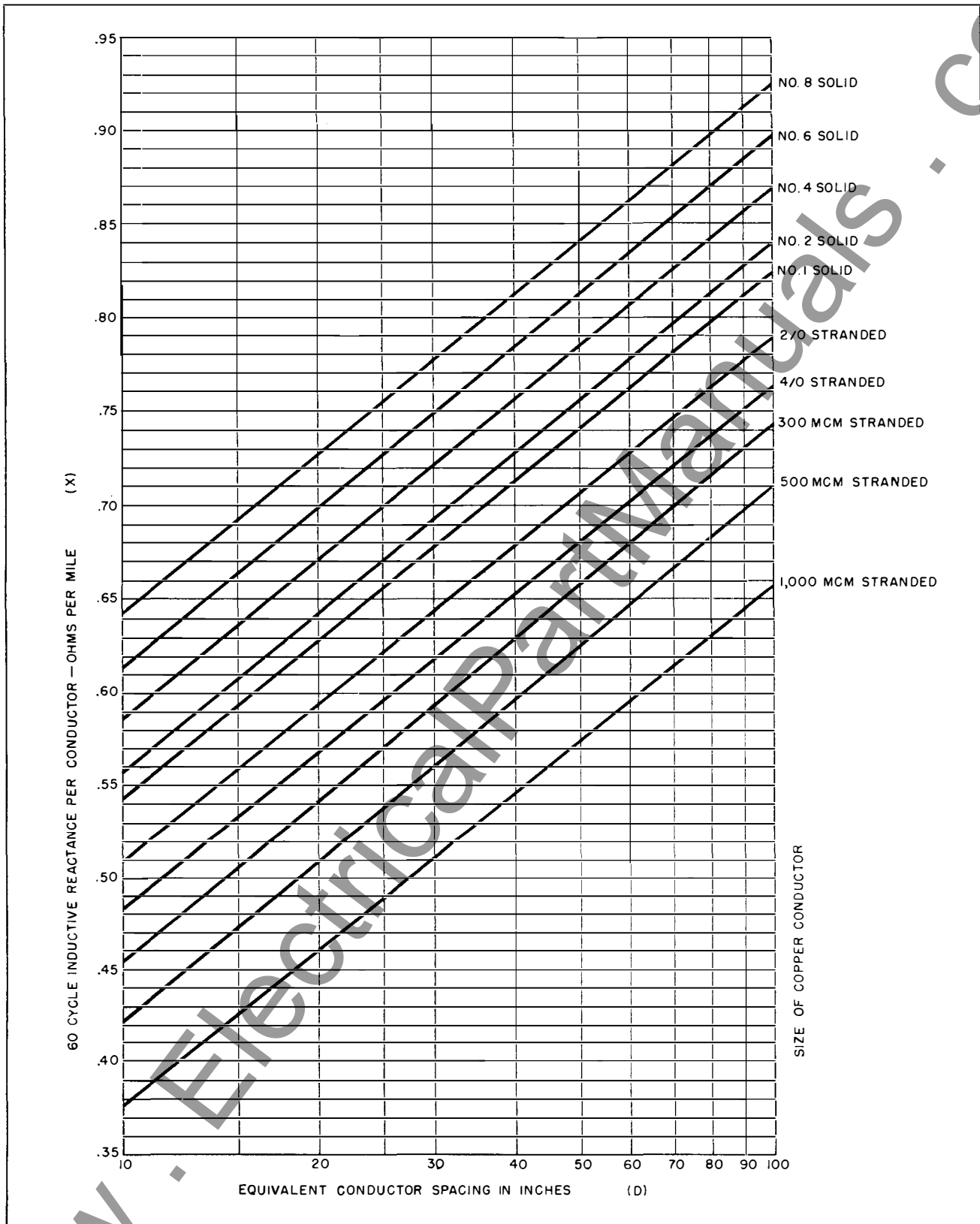

FIG. 9. Reactance Chart (60-Cycle Inductive Reactance vs. Equivalent Conductor Spacing for Various Sizes of Copper Conductor)

voltage charts taken at the load center indicate variations. The modified settings are generally made on the basis of an error in the value of the length, L. Thus if the load center voltage falls at periods of high load, both resistance and reactance compensation are increased, and if the load center voltage rises at periods of high loads, both resistance and reactance compensation are decreased.

The resistance compensation setting can be found by means of the following formula:

$$\text{Resistance Setting} = 125 \left(\frac{RLIK}{V} + \frac{Dr}{100} \right)$$

where R is the a-c resistance of the feeder in ohms per conductor per mile.

Table No. 1, page 11, gives values of R for various conductor sizes.

L is the length of the feeder in miles.

I is the rated full-load current of the regulator as indicated on the nameplate for the stator connection employed.

K is a constant determined by the application. For single-phase applications, the constant is 2; and for three-phase applications, it is 1.73.

V is the line-to-line voltage.

Dr is the percent resistance drop which occurs in any transformer and distribution line which may be located between the end of the feeder and the load center. This drop must be calculated on a basis of full-load current in the regulator.

The reactance compensation setting can be calculated by means of the following formula:

$$\text{Reactance Setting} = 125 \left(\frac{XLIK}{V} + \frac{Dx}{100} \right)$$

where X is the reactance of the feeder in ohms per mile per conductor.

The curves in Fig. 9 give values of X for various conductors and equivalent conductor spacings. The equivalent conductor spacing D for single-phase feeders is taken as the distance between conductors. For three-phase feeders, D is equal to the cube root of the product of the three conductor spacings. Thus if the conductors form an equilateral triangle, the spacing between any two conductors

is equal to D. If the conductors are in line, D is equal to the $\sqrt[3]{2}$ times the spacing between either end conductor and the center one.

L is the length of the line in miles.

I is the rated full-load current of the regulator as given on the nameplate for the stator connection employed.

K is a constant determined by the application. For single-phase applications, the constant is 2; and for three-phase applications, it is 1.73.

V is the line-to-line voltage.

Dx is the percent reactance drop which occurs in any transformer and transmission line located between the end of the feeder and the load center.

SAMPLE CALCULATIONS

Assume that three 50-kva, 10 percent regulation, Type SI regulators are to be wye-connected to a three-phase feeder. The feeder is rated at 1500 kva and is operated at 4330 volts line to line. Full load current is 200 amperes. The regulators are rated at 2500 volts and 200 amperes full load. Assume that the conductors are No. 4/0, stranded cable mounted in line horizontally with two feet between adjacent conductors. The feeder length is two miles and the percent drop in the transformer and distribution line is 2 percent for both resistance and reactance.

For the assumed conductor size, Table No. 1, page 11, gives R = 0.303 ohm per conductor per mile.

This value is then substituted in the resistance setting formula and gives: Resistance Setting = $125 \left(\frac{0.303 \times 2 \times 200 \times 1.73}{4330} + \frac{2}{100} \right) = 8.6$ volts

For the assumed conditions $D = \sqrt[3]{2 \times 2 \times 12} = 30.2$ inches.

For D = 30.2 inches and No. 4/0 conductor, Fig. 9 gives X = 0.62 ohm per conductor per mile.

Substituted in the reactance setting formula this gives: Reactance Setting =

$$125 \left(\frac{0.62 \times 2 \times 200 \times 1.73}{4330} + \frac{2}{100} \right) = 14.9 \text{ volts.}$$

MAINTENANCE

- c. Remove the spur gear.
- d. Loosen the set-screws which hold the adjusting nuts in place.
- e. Remove the adjusting nuts with a spanner wrench.
- f. Remove the worm by tapping on either end of the shaft to drive one of the bearing cups out.

REASSEMBLY OF MACHINE

When reassembling the machine, a reverse procedure to that used in disassembly should generally be followed. When reassembling the worm housing, tap on the worm shaft lightly while tightening the adjustment nuts to make sure that the bearings are seated properly. Also position the worm by means of the adjustment nuts so that the spur gears mesh properly. Tighten the adjustment nuts so that a slight drag is felt when turning the worm by hand by means of the large spur gear. The idler gear should be removed for this adjustment.

When replacing the worm gear, heat it first in an oven or over a gas flame to about 300 or 400 degrees F. If the gear's position is marked before disassembly, it can be easily returned to its correct position before it tightens up on the shaft.

When replacing the worm housing, check for proper meshing of the worm and worm gear. There should be a backlash of approximately one tooth on the large spur gear.

By spot-marking the rotor winding and large spur gear in the neutral position while the machine is out of the tank, the machine can easily be set on neutral after it is tanked. This facilitates the proper location of the position indicator.

After the machine is completely reassembled, it should be pressure-tested to check its seal. This can be done by applying an internal pressure of five pounds per square inch. There should be no appreciable drop after a six-hour period. Leaks above the Inerteen can be found by brushing the gasket-sealed joints with a suitable solution such as soap and glycerine.

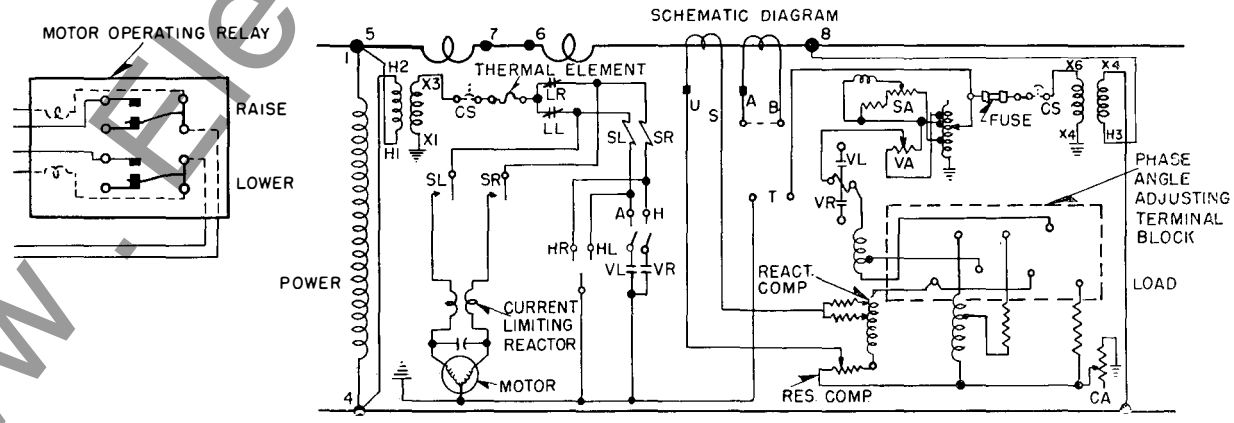
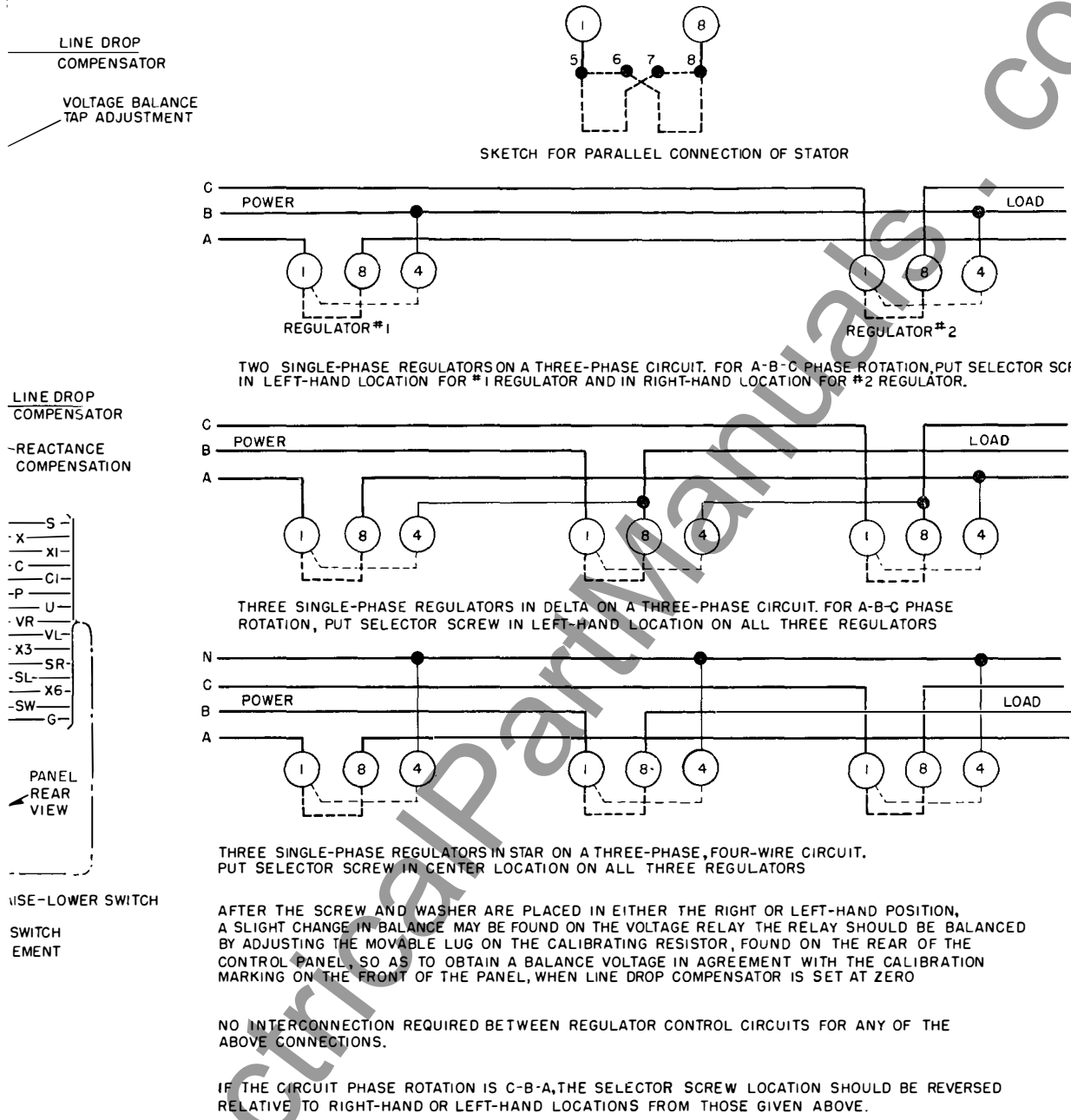
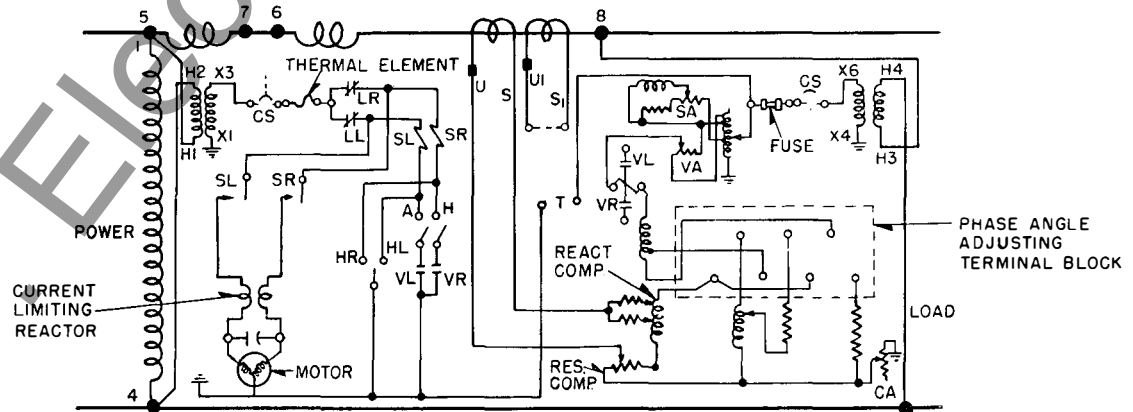
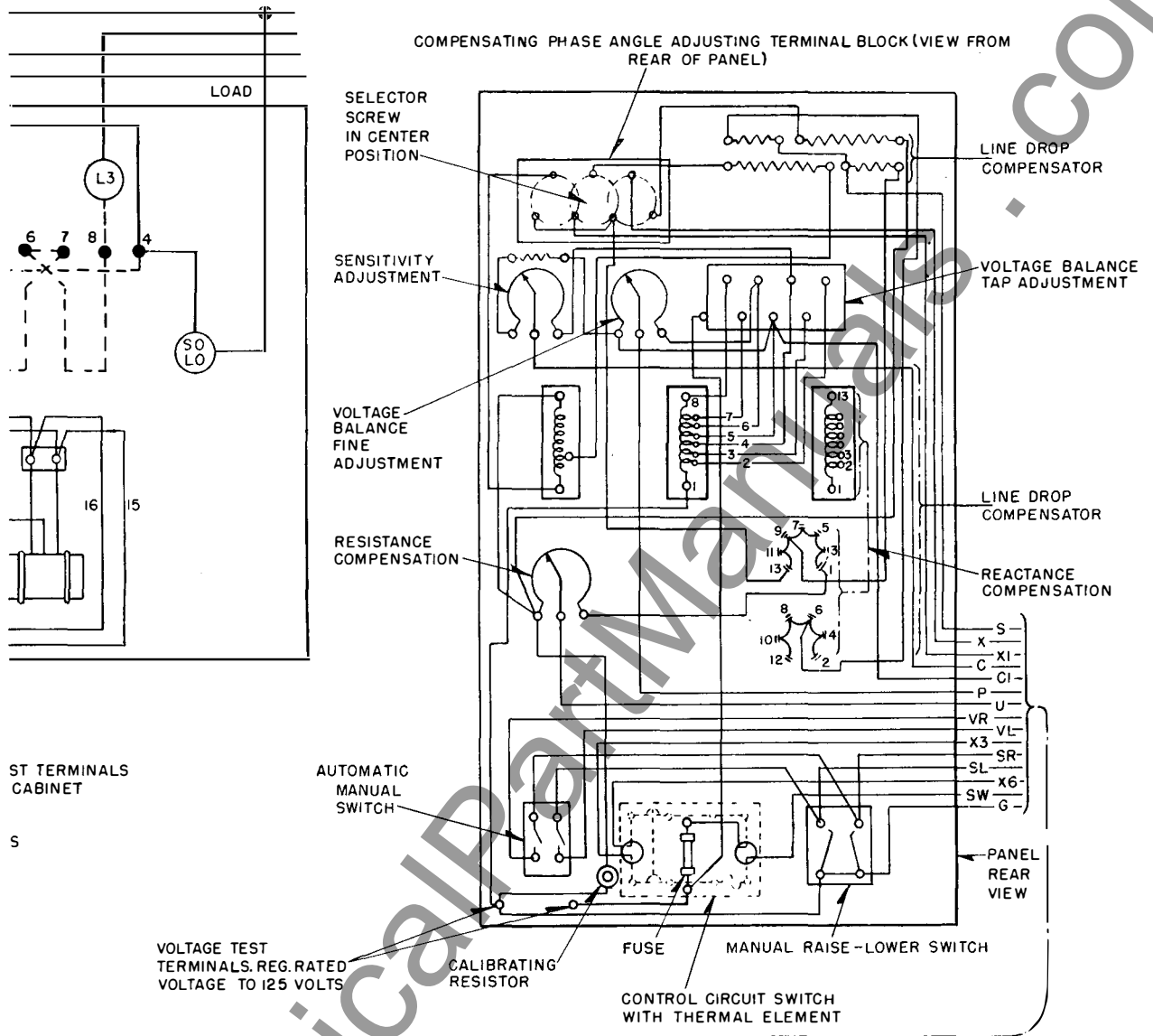

FIG. 12. Wiring Diagram of Typical Regulator, Type SI

www.ElectricalPartManuals.com



SCHEMATIC CIRCUITS FOR ONE REGULATOR AND CONTROL

FIG. 13. Wiring Diagram of Typical Regulator, Type STI

www.ElectricalPartManuals.com



RECEIVING • TESTING • RECONDITIONING

INSTRUCTIONS

INERTEEN[®]

INSULATING FLUID

P.D.S. 7336-9

for

Electrical Apparatus

WESTINGHOUSE ELECTRIC CORPORATION
SHARON PLANT • TRANSFORMER DIVISION • SHARON, PA.

INERTEEN* INSULATING FLUID

P.D.S. 7336-9

Inerteen is a synthetic non-inflammable and non-explosive insulating and cooling liquid. It has proved its suitability for use in all Westinghouse Inerteen insulated apparatus. In order to insure the proper performance of the apparatus, only Westinghouse Inerteen should be used.

This publication gives the instructions for handling, inspection, and maintenance which experience has shown are important in obtaining the best service from the Inerteen.

* Registered trade-mark for Westinghouse Askarel

RECEIVING, HANDLING, STORING

SHIPMENT

Inerteen is shipped in tank cars, drums, or cans. The modern tank cars are usually lagged to prevent rapid fluctuations in temperature during transit and thus reduce the amount of expansion and contraction of Inerteen. Changes in the volume of the Inerteen due to temperature changes tend to cause breathing in of moist air resulting in condensation of moisture inside the container, and lowering of the dielectric strength of the Inerteen.

When shipped in drums, the Inerteen and the drums are both heated above room temperature while the drums are being filled, and the bungs are tightened immediately after filling. After cooling to normal temperature, the bungs are again tightened. The drums are provided with screw bungs having gaskets to prevent admission of water.

When shipped in cans, the cans as well as the Inerteen are heated above room temperature while being filled and are hermetically sealed immediately after filling.

STORING

Drums. As soon as a drum of Inerteen has been unloaded, the bung should be examined and tightened if it is loose. It is possible for bungs to become loosened by change in temperature or rough handling in transit. If loosened, be sure Inerteen is tested before using, or combining it with good Inerteen.

It is very desirable that Inerteen in drums be stored in a closed room. Outdoor storage of Inerteen is always hazardous to the Inerteen and should be avoided if at all possible. If it is necessary to store Inerteen outside, protection against direct contact of rain and snow should be provided. Drums stored outdoors should be placed so that bungs will be protected from moisture. It is desirable to cover the drums with a tarpaulin.

Cans. Cans containing Inerteen must not be exposed to the weather. Seals should be kept intact until the Inerteen is actually needed.

Screw caps are provided on the cans to use when the Inerteen is only partially removed after hermetic seal has been broken. By replacing the screw caps, contamination by moisture and dirt will be retarded, but the Inerteen must be tested just before using.

Storage Tank. The storage tank should be mounted on piers so that it will not touch the ground, and will be accessible to all points for inspection for leakage.

It is desirable to maintain the temperature of the Inerteen and tank a little above the temperature of the surrounding air as this prevents condensation of moisture in the tank which would affect the dielectric strength of the Inerteen.

The tank should preferably have a convex bottom, allowing for the installation of a drain cock at the lowest point for removing dirt or tank scale which might settle out. As Inerteen is heavier than water, most all of any water present will, in time, rise to the top of the Inerteen. A valve somewhere near the normal top level of the Inerteen should be provided for drawing off water-contaminated Inerteen. Provision for drawing off the Inerteen should also be made near the bottom of the tank.

HANDLING

Caution: Inerteen is a skin irritant. Unnecessary contact with this liquid or its vapor, particularly when it is hot, should be avoided. Especially the eyes, nose, and lips are affected when Inerteen comes in contact with them. Certain safety precautions must be observed when handling Inerteen.

In case Inerteen comes in contact with the skin, the parts affected should be thoroughly washed in soapy water and followed by an application of cold cream. A supply of these materials should be kept available at all times where personnel are working with Inerteen. Continued exposure may cause eruptions on certain individuals due to the absorption of Inerteen through the pores

RECEIVING, HANDLING, STORING

of the skin. Cleanliness among workmen handling Inerteen is a very good safeguard against such effects. Application of castor oil is recommended for the eyes, castor oil or cold cream for the nose and lips.

Hot apparatus should not be opened except in well-ventilated places. Large quantities of Inerteen should be handled in a closed system. Workmen should be protected from frequent contact with any appreciable vapor concentration and from frequent skin contact with Inerteen.

In case Inerteen is spilled on one's clothing, the clothing should be changed as soon as possible and the soiled clothing laundered before it is worn again. Gloves such as Westinghouse S# 1389 974 should be worn when it is necessary to put one's hand into Inerteen or when parts of apparatus must be handled wet.

Mineral oil is completely miscible with Inerteen and it is practically impossible to separate them. Therefore, it is important to avoid contaminating Inerteen with any kind of oil, since its presence changes the non-inflammable and non-explosive characteristics of Inerteen.

Note: The Inerteen should be sampled and tested before being transferred from the container to the apparatus, particularly in cases where the wire lock-seal has been broken. In cases where the apparatus is received with the Inerteen installed, the Inerteen should be sampled and tested before the apparatus is put into service, as described later in this book.

When putting new apparatus into service, see that the apparatus tank is free from moisture and foreign material.

Although the drums and tank cars are thoroughly washed and dried at the refinery before filling, a certain amount of scale is sometimes loosened from the inside in transit. Therefore, Inerteen which has not been filtered should be strained through three or more thicknesses of muslin, or other closely woven cotton cloth which has been thoroughly washed and dried to remove the sizing. The straining cloths may be stretched across a funnel of large size and should be renewed at frequent intervals.

Important: Extreme precautions must be taken to insure the absolute dryness and cleanliness of the apparatus before filling it with Inerteen, and to prevent the entrance of water and dirt during the transfer of the Inerteen to the apparatus.

The preparation and filling of outdoor apparatus should preferably be done on a clear, dry day; if this is not possible, protection against moisture must be provided.

All vessels used for transferring the Inerteen should be carefully inspected to see that they are absolutely dry and free from contamination.

Important: Always use all-metal hose or pipe when handling the Inerteen. A hose made of natural rubber should not be used. Inerteen can easily become contaminated from the sulphur in the natural rubber, and should not be allowed to come in contact with it.

When it is necessary to transfer Inerteen from warm surroundings to apparatus exposed to extremely cold weather, even when the dielectric strength at room temperature is high, it is desirable to circulate the Inerteen through an Inerteen conditioner at room temperature. A similar procedure is also advisable in the case of apparatus erected inside and later exposed to cold weather, the reason being that Inerteen will absorb more water at higher temperatures which will be thrown out of solution at lower temperatures. The remainder will be in suspension in the Inerteen and will lower the dielectric strength.

A drum of cold Inerteen when taken into a warm room will "sweat", and the resulting moisture on the surface may mix with the Inerteen as it flows from the drum. Before breaking the seal, the drum should therefore be allowed to stand long enough to reach room temperature, which may require eight hours, or even longer under extreme temperature conditions.

Cleaning Contaminated Drums. The cleaning of drums which have contained used Inerteen requires great care in order to insure a thoroughly clean drum.

It is preferable to return such drums to the supplier where adequate cleaning facilities are available, rather than to attempt to clean them.

If it is necessary to clean such drums, the following procedure is recommended:

Rinse the drum thoroughly with gasoline or benzine, using about one gallon each time, until the solvent shows no discoloration after using. Allow it to drain, then pump out the last traces of solvent with a vacuum pump, using a brass pipe flattened at the lower end to explore the corners of the drum.

Caution: Do not use a steel pipe because of the danger of a spark igniting the gasoline or benzine vapor.

Next, heat the drum with bunghole down, in a ventilated oven at a temperature of at least 88°C. (190°F.) for sixteen hours. (A simple oven for this purpose may be made from sheet metal and heated with steam or an electric heater.) Blow out the drum with dry nitrogen or dry air to remove any lingering explosive vapors. Screw the bung on tightly before removing the drum from the oven. Use a new washer with the bung to insure a tight seal.

Caution: Open flames must always be kept away from the oven to prevent igniting inflammable gases which might be remaining in drum when placed in the oven.

Refilling Drums. The practice of refilling drums with Inerteen is undesirable and should be avoided whenever possible, for unless the utmost precautions are taken, the Inerteen is likely to become contaminated.

If it is necessary to refill them for storage, drums which have been used only for clean, dry Inerteen should be reserved for this purpose. They should be closed immediately after being emptied, to exclude dirt and water. After refilling, they should be examined to see that they do not leak.

Whenever a drum is to be filled with Inerteen, the temperature of the drum and of the Inerteen should be at least 5.5°C. (10°F.) higher than the air, but the temperature of the drum need not be the same as that of the Inerteen.

A new washer should be used with the bung each time the drum is refilled, to insure a tight seal. These washers may be obtained from the nearest Westinghouse Office and it is recommended that a supply be kept on hand. Natural rubber composition washers should **never** be used as they would be attacked by the Inerteen.

Drums to be refilled with Inerteen for storage should be plainly marked with paint for identification.

SAMPLING AND INSPECTION

A good fireproof insulating liquid is one that will act as an insulating liquid, will carry the heat away from the apparatus, and is fireproof. Westinghouse Inerteen meets these requirements with the following characteristics:

1. High dielectric strength.
2. Freedom from inorganic acid, alkali, and corrosive sulphur. (To prevent injury to insulation and conductors)
3. Low viscosity. (To provide good heat transfer)
4. Low pour point.
5. Fireproof.

CAUSES OF DETERIORATION

The principal causes of deterioration of Inerteen are:

1. Presence of water.
2. Arcing.

Condensation from moist air due to breathing of the apparatus, especially when the apparatus is not continuously in service, may injure the Inerteen. (The moist air drawn into the apparatus condenses moisture on the surface of the Inerteen and inside of the tank.) The Inerteen may also be contaminated with water through leakage such as from leaky cooling coils or covers.

Arcing or burning in Inerteen produces finely divided carbon and gases which are mostly hydro-

gen chloride. Hydrogen chloride in the presence of moisture forms hydrochloric acid which may soon damage the insulation in the apparatus and cause rusting of ferrous materials.

Since hydrogen chloride is formed quickly after the arcing occurs, neither the Inerteen nor the apparatus should be exposed to the atmosphere (which always contains more or less moisture) until an attempt has been made to remove the hydrogen chloride. See Reconditioning, Page 7, for the method of purification.

SAMPLING INERTEEN

The dielectric strength of Inerteen is affected by the most minute traces of certain impurities, particularly water. It is important that the greatest care be taken in obtaining the samples and in handling them to avoid contamination. There have been low dielectric test results reported from the field which, upon investigation, have been found to be largely a matter of carelessness in handling.

All sampling and testing equipment must be thoroughly dry and clean. It is recommended that sampling and testing equipment used for handling Inerteen and servicing Inerteen be used for no other purpose. Care must be used in taking samples of Inerteen and sealing them prior to testing. It is

desirable that samples of Inerteen be removed from any container on clear days only, and when the temperature of the Inerteen is at least as high as the temperature of the surrounding air.

Use only tin containers with screwed metal caps or glass bottles with Inerteen-resistant stoppers to hold Inerteen samples. If it becomes necessary to use other than factory sampling containers, they should be rinsed with clean naphtha, washed with strong soap suds, and rinsed thoroughly in hot water, and then dried at approximately 110°C. for four hours with neck down in a circulating air oven. If the containers are not used immediately after cleaning, they should be sealed tightly and stored in a dry, clean place.

Provision is made on all Inerteen transformers to obtain a top sample of the Inerteen, however on a transformer that is in operation, a sample may be taken from either the top or bottom since any moisture present will be mixed in, due to circulation of the Inerteen. In sampling, allow a small amount of Inerteen to run out to flush the sampling connection clean before collecting the sample. The Inerteen should be put into the sample containers immediately and the caps screwed on tightly. The label for each container should be marked clearly with the serial number of the transformer or compartment from which the Inerteen was taken.

Before taking samples from a storage tank, the Inerteen should be allowed to settle for approximately twelve hours so that if there is any moisture present, it, having a lower specific gravity, will rise to the top where the sample is to be taken. A clean sneak-thief should be used to obtain the samples. Essentially, the same precautions to prevent moisture and dirt contamination should be used as outlined above.

Quantity of Sample. It is recommended that one 16 oz. bottle of Inerteen be taken as a sample for testing. At least one sample should be taken from a tank car of Inerteen. One sample may be taken from each drum, or if desired, a composite sample may be made from Inerteen from five drums, provided all of the drums are airtight. When the bung is first loosened, a hissing sound should be heard, which indicates that the drum has been airtight. If the test of the composite sample is not satisfactory, a sample from each of the drums represented should be tested.

When drums have been stored exposed to the weather, a sample from each drum must be tested to determine if it is suitable for use.

PERIODIC INSPECTION

It is desirable that periodic inspections of Inerteen apparatus be made and that samples of Inerteen be taken from each and from all compartments of any apparatus and tested after a short period of service (approximately three months for transformers). Following this, when operating conditions permit, routine sampling and testing of the Inerteen at intervals of six months to one year are suggested. Accurate records should be kept of such inspections and tests and if the Inerteen shows a dielectric strength of less than 22 kv, it should be conditioned. If facilities are not available for testing Inerteen, see "Westinghouse Inerteen Testing Service" below, and also P.L. 44-860. When an appreciable amount of Inerteen is removed from any apparatus, it should be replaced with an equal amount of new Inerteen so that the liquid level in the apparatus is maintained. The Inerteen used for replacement purposes should have a dielectric strength of not less than 30 kv.

INERTEEN TESTING SERVICE

Many users of Inerteen do not have the necessary facilities for testing it. In order that these users may be able to make the periodic tests recommended, Westinghouse Electric Corporation has established an Inerteen testing service to provide a careful test by experienced engineers, and a prompt report of test results.

Two special 16 oz. sample bottles per mailing container (W) S#1608 629, as well as necessary packing and printed matter, may be obtained by contacting the nearest Westinghouse Office. (The bottle and the container will not be returned to the customer.)

After drawing the sample of Inerteen, the customer should seal the bottle and mail it to the Westinghouse Electric Corporation, Plant Laboratory, Sharon, Pa. To simplify these details, an instruction and order sheet and a printed return label have been included in the carton container. The instructions cover the taking of the sample and its proper preparation for mailing. *The order sheet must be sent to the nearest Westinghouse Office.*

When samples of Inerteen are received for testing, they are sent to the Plant Laboratory and tested in accordance with methods described under "Testing Methods," which follows and is part of this Instruction Book.

In addition to dielectric tests, Westinghouse is also prepared to make a physical and chemical examination if so requested. (The customer should plainly indicate the type of service desired.)

The physical and chemical examination consists of an examination of the Inerteen by a competent chemist. Recommendations will be made as to the suitability of the Inerteen for continued use, whether it would be desirable and economical to clean it, and in a general way, the preferred method of cleaning. In submitting samples for this service, the

history of the Inerteen represented should be given as completely as possible.

Power factor test of Inerteen at 60 cycles can be made.

(For details refer to the nearest Westinghouse Office.)

CHARACTERISTICS AND RECONDITIONING

CHARACTERISTICS

Inerteen is chemically stable. It is straw-yellow in color. It is not affected by reaction with other materials regularly used in the manufacture of Inerteen apparatus. It is non-oxidizing and non-corrosive at temperatures considerably above those normally obtained in Inerteen apparatus. Inerteen will not sludge under any operating condition.

The dielectric strength of Inerteen will compare favorably with that of insulating oil when tested under the same conditions. Quality samples of Inerteen tested under laboratory conditions may show a dielectric strength in excess of 40 kv. Care must be exercised in handling and testing Inerteen. Inerteen must be kept in clean, sealed containers to prevent loss by evaporation or contamination by moisture or dirt.

Inerteen exerts a strong solvent action on most varnishes, gums, and paints. Such materials are not used in the construction of Inerteen apparatus. No materials should be used in Inerteen apparatus except those approved by the Westinghouse Electric Corporation.

Inerteen has an irritating effect upon the skin. If it is necessary to handle it, see the caution note under Receiving, Storing, and Handling. (See Page 3.) It should be remembered that mineral oil is completely miscible with Inerteen; in fact, it is practically impossible to separate mineral oil and Inerteen.

Inerteen P.D.S. 7336-9 has an improved characteristic so that, when arcing occurs, the insulating materials are not so quickly or so greatly impaired as a result of the liberation of hydrogen chloride. Inerteen 7336-7, which was supplied in Inerteen transformers previous to September 1, 1945, can easily be converted to 7336-9 Inerteen. For complete information on this conversion, request Engineering Data Letter No. 1337-A from any Westinghouse Electric Corporation Office.

Specific Characteristics of Inerteen. As outlined in "Method of Testing Askarels A.S.T.M. D901-49T", the specific characteristics of Inerteen are:

1. Burn point: None
2. Chemical stability: No generation of free chlorides under normal operating conditions
3. Color: (Maximum) 150 A.P.H.
4. Condition: Clear
5. Dielectric constant:
 - At 1000 cycles 77°F (25°C), 4.0 to 4.3
 - At 1000 cycles 212°F (100°C), 3.5 to 3.8
6. Dielectric strength: (Minimum) 77°F (25°C)
 - At point of shipment, 35 kv
 - At point of receipt, 30 kv
7. Electrical resistivity: (Minimum)
 - 100 x 10⁹ ohms/cm³ (212°F (100°C) at 500 volts d-c)
8. Fixed chlorine content: (Minimum) 59.1 percent
9. Free chlorides: Less than 0.10 ppm
10. Neutralization number: Less than 0.010 mg. of NaOH/gram.
11. Pour point: (Maximum) minus 25.6°F (minus 32°C)
12. Refractive index
 - At 77°F (25°C), 1.6137 to 1.6157
13. Specific gravity: (Minimum)
 - At 60°F/60°F (15.5°C/15.5°C), 1.560
14. Viscosity: (Maximum)
 - At 100°F (37.8°C), 54 seconds

RECONDITIONING

Reconditioning will be necessary to remove water, dirt, and hydrogen chloride which may be present and contaminating the Inerteen.

The blotter filter press and the Inerteen conditioner (both of which will be explained later in this book under "Apparatus for Reconditioning") will remove water and dirt deposits which may be present. Of the two methods, the Inerteen conditioner is the most effective in removing these two contaminating agents. Any equipment used for filtering

Inerteen should first be thoroughly cleaned with benzine or naphtha. Every trace of any material foreign to Inerteen must be removed. If at all possible separate equipment should be used for filtering Inerteen only.

Hydrogen chloride, caused by arcing, may be eliminated by vigorously bubbling dry nitrogen through the Inerteen. The nitrogen should be passed through the drain valve at the bottom of the apparatus and allowed to escape through a vent at the top. The nitrogen should be discharged through a pressure regulator attached to a stand pipe above the level of the Inerteen in the apparatus to prevent the Inerteen from flowing into the regulator. The nitrogen should be bubbled through the Inerteen at a rate of one to three cubic feet per minute for a period of four to six hours. This will require from

two to eight cylinders (220 cu. ft. each) of dry nitrogen, based on apparatus containing 150 to 2000 gallons of Inerteen.

Immediate application of the bubbling process will reduce the destructive action of the hydrochloric acid on the working parts and insulation, thereby making it likely that the materials not damaged by arcing may be used in repairing the apparatus. Also, use of the process will in most cases make it possible to satisfactorily reclaim the arced Inerteen.

After the hydrogen chloride has been removed by the bubbling process, the Inerteen should be reclaimed by use of an Inerteen conditioner.

There is no commercially suitable method for separating transformer oil from Inerteen.

TESTING METHODS

Instructions for all tests listed correspond in general to the recommendations of the American Society for Testing Materials.

DIELECTRIC STRENGTH TEST

Apparatus. The testing transformer and the source of supply of energy shall not be less than $\frac{1}{2}$ kva, and the frequency shall not exceed 100 cycles per second. Regulation shall be so controlled that the high tension testing voltage taken from the secondary of the testing transformer can be raised gradually without opening either primary or secondary circuit. The rate of rise shall approximate 3000 volts per second. The voltage may be measured by an approved method which gives root-mean-square values.

Some protection is desirable to prevent excessive flow of current when breakdown of the Inerteen takes place. This protection preferably should be in the primary or low voltage side of the testing transformer. It is not especially important for transformers of 5 kva or less, as the current is limited by the impedance of the transformer.

The standard test cup for holding the sample of Inerteen shall be made of a material having a suitable dielectric strength. It must be insoluble in and unattacked by Inerteen or gasoline, and non-absorbent as far as moisture, Inerteen, or gasoline are concerned.

The electrodes in the test cup between which the sample is tested shall be circular discs of polished brass or copper, 1 in. in diameter, with square (90°)

edges. The electrodes shall be mounted in the test cup with their axes horizontal and coincident, with a gap of 0.100 in. between their adjacent faces, and with tops of electrodes about $1\frac{1}{4}$ in. below the top of the cup. (A suitable test cup is shown in Fig. 1, and portable testing outfits in Figs. 2, 3, and 4.)

PROCEDURE

The spacing of electrodes shall be checked with a standard round gauge having a diameter of 0.100 in., and the electrodes then locked in position.

The electrodes and the test cup shall be wiped clean with dry, calendered tissue paper or with a clean, dry chamois skin and thoroughly rinsed with Inerteen-free, dry gasoline or benzine until they are entirely free from fibers.

The test cup shall be filled with dry, lead-free gasoline or benzine, and voltage applied with uniform increase at the rate of approximately 3000 volts (rms) per second until breakdown occurs. If the dielectric strength is not less than 25 kv, the cup shall be considered in suitable condition for testing the Inerteen. If a lower test value is obtained the cup shall be cleaned with gasoline and the test repeated.

Note: Evaporation of gasoline from the electrodes may chill them sufficiently to cause moisture to condense on their surface. For this reason, after the final rinsing with gasoline, the test cup should be immediately filled with the Inerteen which is being tested, and the test made at once, or the electrodes should be thoroughly dried before using.

The temperature of the test cup and of the Inerteen when tested shall be the same as that of the room, which should be between 68°F and 86°F. (20°C and 30°C.) Testing at lower temperatures is likely to give variable results which may be misleading.

The sample in the container shall be agitated with a swirling motion (to avoid introducing air) so

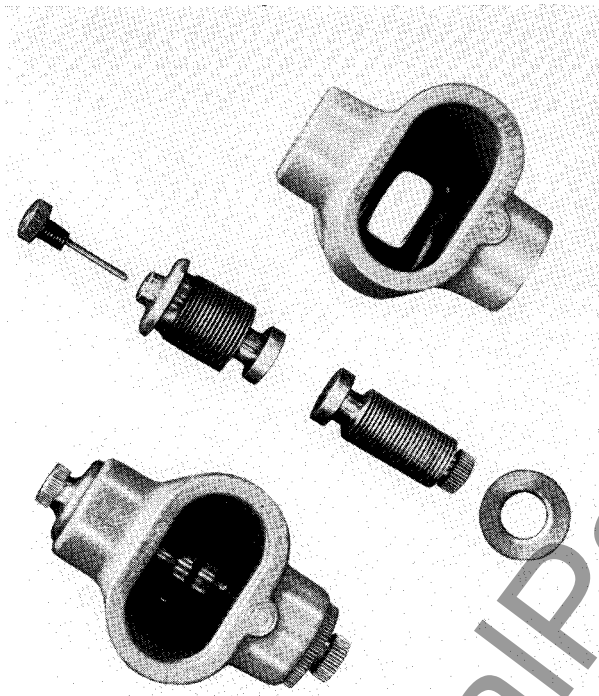

FIG. 1. Fluid Test Cup for Dielectric Test



FIG. 2. Portable Oil Testing Set, 1/2 Kva, 35,000 Volts

as to mix the Inerteen thoroughly before filling the test cup. This is even more important with used Inerteen than with new Inerteen as the impurities may be precipitated and the test may be misleading.

The cup shall be filled with Inerteen to a height of no less than 0.79 in. (20 mm) above the top of the electrodes.

The Inerteen shall be gently agitated by rocking the cup and allowing it to stand in the cup for three minutes before the first and one minute before each succeeding puncture. This will allow air bubbles to escape.

Voltages shall be applied and increased uniformly at a rate of approximately 3000 volts (rms) per second until breakdown occurs as indicated by a continuous discharge across the gap. (Occasional momentary discharges which do not result in a permanent arc may occur; these should be disregarded.)

TESTS

a. Except as specified in (b) one breakdown test shall be made on each of five fillings of the test cup. If the average deviation from the mean exceeds 10 percent or if any individual test deviates more than 25 percent from the average, additional tests shall be made. The dielectric strength shall be determined by averaging the first five tests that conform to the allowable variations.

b. When Inerteen is tested in considerable quantity, so that the time required for testing is excessive and when it is merely desired to determine whether the breakdown safely exceeds the limit specified, or in those cases where the amount of Inerteen available for test may be very limited, one breakdown test shall be made on each of two fillings of the test cup. If neither breakdown is below this value, the Inerteen may be considered satisfactory and no further tests shall be required. If either of the breakdowns is less than the specified value a breakdown shall be made on each of three additional fillings and test results analyzed in accordance with (a).

Report. The report shall include the volts (rms value) at each breakdown and the average of the two or five breakdowns and the temperature of the Inerteen at the time of the test.

POUR TEST

Note: The procedures covered by the following instructions for the pour test, and especially the neutralization test, require spec-

TESTING METHODS

ial equipment. The neutralization test must be made by a competent chemist, preferably one specializing in this particular field. Customers who do not possess these facilities are offered, at nominal cost, the use of the Westinghouse Inerteen Testing Service. Contact the nearest Westinghouse Office for details.

The pour point of Inerteen is the lowest temperature at which it will pour or flow when it is chilled without disturbance under certain definite specified conditions.

Apparatus. The test jar (see Fig. 4) shall be clear glass, of cylindrical shape, approximately $1\frac{1}{4}$ in. inside diameter and $4\frac{1}{2}$ to 5 in. high, with a flat bottom. An ordinary 4 oz. Inerteen sample bottle may be used if the test jar is not available.

The cork shall fit the test jar, and shall be bored centrally to accommodate the test thermometer.

The thermometer shall conform to A.S.T.M. specifications for pour test. It may be ordered as: A.S.T.M. thermometer low cloud and pour, -70°F (-56.7°C) to 70°F ($+21.1^{\circ}\text{C}$).



FIG. 3. Portable Trunk Type Insulating Liquid and Insulating Testing Set, 5 Kva, 30,000/60,000 Volts

The jacket shall be of glass or metal and shall be watertight, of cylindrical form, flat bottomed, about $4\frac{1}{2}$ in. deep, with inside diameter $\frac{1}{2}$ in. greater than outside diameter of the test jar.

A disc of cork or felt $\frac{1}{4}$ in. thick and of the same diameter as the inside of the jacket shall be placed in the bottom of the jacket.

The ring gasket shall be about $\frac{3}{16}$ in. thick, made to fit snugly around the outside of the test jar and loosely inside the jacket. This gasket may be made of cork, felt, or other suitable material, elastic enough to cling to the test jar and hard enough to hold its shape. The purpose of the ring gasket is to prevent the test jar from touching the jacket.

The cooling bath shall be of a type suitable for obtaining the required temperature. The size and shape of the bath are optional but a support suitable for holding the jacket firmly in a vertical position is essential. For determination of very low pour points, a smaller insulated cooling bath may be used and the test jar placed directly in it. The required bath temperature may be maintained by refrigeration if available, otherwise by suitable freezing mixtures.

Procedure. The Inerteen to be tested shall be brought to a temperature at least 25°F . (14°C .), above the approximate cloud point. Moisture, if present, shall be removed by any suitable method, as by filtration through dry filter paper until the Inerteen is perfectly clear. (Such filtration shall be made at a temperature at least 25°F . (14°C .), above the approximate cloud point.) The Inerteen shall be poured into the test jar, to a height of not less than 2 in. or more than $2\frac{1}{4}$ in. When necessary, the Inerteen shall be heated in a water bath just enough so it will pour into the test jar.

The test jar shall be tightly closed by the cork carrying the test thermometer in a vertical position in the center of the jar; the thermometer bulb should be immersed so that the beginning of the capillary shall be $\frac{1}{8}$ in. below the surface of the Inerteen.

Heat without stirring to a temperature of 115°F . (46.1°C .) in a bath maintained at not higher than 118°F . (47.8°C .). The Inerteen shall then be cooled to 90°F . (32.2°C .) in air or in a water bath approximately 77°F . (25°C .) in temperature.

The cork or felt disc shall be placed in the bottom of the jacket and the test jar, with the ring gasket, 1 in. above the bottom, shall be inserted into the jacket. The disc, gasket, and inside of jacket shall be clean and dry.

During the cooling of the Inerteen, care shall be taken not to disturb the mass of the Inerteen nor to permit the thermometer to shift in the Inerteen.

The temperature of the cooling bath shall be adjusted so that it is below the pour point—approximately -25.6°F (-32°C)—of the Inerteen by not less than 15°F . (8.3°C) nor more than 30°F . (16.7°C), and the cooling bath shall be maintained at this temperature throughout the test. The jacket containing the test jar shall be supported firmly in a vertical position in the cooling bath so that not more than 1 in. of the jacket projects out of the cooling medium.

Beginning at a temperature 20°F . (11.1°C .) above the expected pour point, at each lower test-thermometer reading which is a multiple of 5°F . (2.8°C), the test jar shall be removed from the jacket carefully and shall be tilted just sufficiently to ascertain whether there is a movement of the Inerteen in the test jar. The complete operation of removal and replacement shall require not more than three seconds. As soon as the Inerteen in the test jar does not flow when the jar is tilted, the test jar shall be

held in a horizontal position for exactly five seconds, as noted by a stop watch or other accurate timing device, and observed carefully. If the Inerteen shows any movement under these conditions, the test jar shall be immediately replaced in the jacket and the same procedure repeated at the next temperature reading 5°F . (2.8°C .) below the previous reading.

The test shall be continued in this manner until a point is reached at which the Inerteen in the test jar shows no movement when the test jar is held in a horizontal position for exactly five seconds. The reading of the test thermometer at this temperature, corrected for error if necessary, shall be recorded. The pour point shall be taken as the temperature 5°F . (2.8°C .) above this solid point.

NEUTRALIZATION TEST

The Neutralization Number is the number of milligrams of potassium hydroxide required to neutralize the acid in one gram of Inerteen.

Solutions Required.

a. Standard Potassium Hydroxide Solution (alcoholic, 0.1 N)—add 6 g. of c.p. solid KOH to 1 liter of c.p. anhydrous isopropyl alcohol. Boil, add 2 g. of c.p. $\text{Ba}(\text{OH})_2$ and boil again. Cool, filter and store in a chemically resistant bottle protected by a guard tube containing soda lime and soda asbestos (Ascarite). Standardize against pure potassium acid phthalate using phenolphthalein as an indicator.

b. Titration Solvent—Add 500 ml. of c.p. benzene and 5 ml of water to 495 ml of c.p. anhydrous isopropyl alcohol.

c. Alpha-Naphtholbenzein Indicator Solution—Prepare a solution containing 10 g. of alpha-naphtholbenzein per liter of c.p. anhydrous isopropyl alcohol.

Procedure. Into a 250 ml Erlenmeyer flask introduce 40 g. of Inerteen weighed accurately. Add 100 ml of the titration solvent and 3 ml of the indicator solution. Titrate immediately at a temperature below 30°C . Consider the end point definite if the color change to green persists for 15 seconds. A blank shall be determined on the solvent.

Calculations. The neutralization number or mg.

$$\text{KOH per g. of Inerteen} = \frac{(\text{A}-\text{B}) (\text{N}) \times 56.1}{\text{W}}$$

A = ml KOH solution required for sample.

B = ml KOH solution required for blank.

N = normality of KOH solution.

W = grams of sample used.

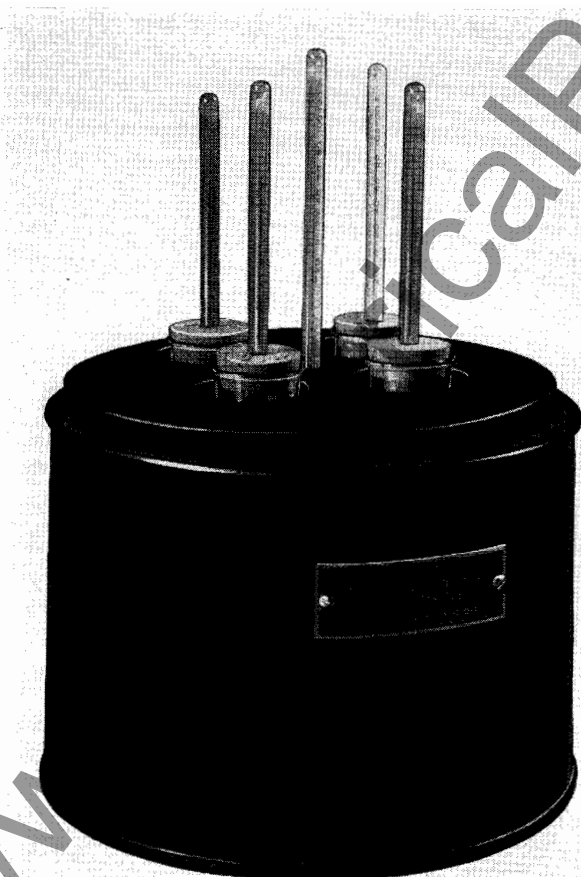

FIG. 4. Apparatus for Pour Test

APPARATUS FOR RECONDITIONING

There are several types of reconditioning apparatus available, the relative advantages of each of which are as follows:

1. The Inerteen Conditioner is the most effective method of removing moisture, dirt, and other contaminating materials from Inerteen.
2. The filter press is suitable for treating Inerteen containing only small quantities of water and dirt.

INERTEEN CONDITIONER

The Inerteen Conditioner consists of a clay container, clay filter, a motor-driven positive pressure pump, attendant valves, gauges, and relief devices, all mounted on a common base.

The motor and pump are combined as a unit and a strainer is provided on input to the pump to prevent entrance of large particles. The units are designed to operate under working pressures up to 60 psi. However, the usual operating pressure is 30 psi to 40 psi. Excessive pressures are prevented by two automatic by-pass valves. One by-pass valve connected across the pump is set to by-pass the Inerteen at a pressure of 60 psi to 70 psi. The other by-pass valve is connected on the discharge side of the conditioner. This latter by-pass valve, releasing at a pressure of approximately 5 psi, will avoid breaking the transformer relief diaphragm when no other relief is provided. Pump pressures are indicated by a pressure gauge.

Seven GPM Unit. The activated clay is contained in a tank mounted on one end of the filter frame. This tank is provided with a cover which incorporates an air-trap and vent to remove air which might be present in the tank and piping. The Inerteen is pumped up through the clay, insuring thorough agitation of the clay and Inerteen. The Inerteen is passed through a wire screen prior to entering the paper filter to remove practically all of the clay. The paper filter consists of 18 frames and 17 plates, alternately spaced, mounted in a yoke. One sheet of filter paper is used between each plate and frame to provide a gasket seal and remove all traces of clay from the Inerteen. (See Fig. 8)

Three GPM Unit. This unit utilizes two tanks, one within the other. The activated clay is held in the inner tank by suitable screens at top and bottom. The space below the inner tank is completely sealed off from the rest of the space between the two tanks. The cover is of double-deck construc-

tion, incorporating the top screen for the inner tank and the solid cover for the outer tank. The Inerteen is pumped into the lower space and is forced up through the activated clay, insuring thorough agitation of the clay and Inerteen. The Inerteen is passed through the fine mesh upper screen and out into the space between the two tanks. The discharge pipe is at the lower end of the outside tank and any air in the Inerteen is trapped in the upper space of the outside tank where it may be drawn off.

Since the density of Inerteen is considerably greater than that of water, moisture will float on the surface of the Inerteen. It is, therefore, considered advisable to condition Inerteen from the top and return it to the bottom of the Inerteen filled apparatus.

One charge of clay is composed of approximately 40 pounds of 15-30 mesh activated clay.* This relatively large volume of clay makes only occasional changes of clay necessary, depending of course on the amount and condition of the Inerteen filtered. Normally one charge will condition approximately 3000 gallons of Inerteen. The coarse granulated clay used gives maximum surface contact between clay and liquid and makes possible a rapid and thorough mixing of the clay and Inerteen to accomplish complete reconditioning of the Inerteen as it passes through the clay tank. The clay granules are removed from the Inerteen by means of fine screen in the 3 GPM filter and by screen and paper in the 7 GPM filter.

The clay never passes through the pump to cause wear on pump parts and consequent loss of pumping capacity. As soon as the charge of activated clay is placed in the tank and the cover clamped in place, the unit is ready for immediate use.

Neither clay nor filter paper can be effectively dried of water after they have once become saturated with Inerteen. Therefore, extreme care should be taken to see that both clay and filter paper are thoroughly dried when placed in the filter.

The clay may be dried in a high temperature oven at 200 deg. C. for six hours and shallow pans are preferred as containers for the clay while drying. A paper drying oven may be used if a high temperature oven is not available, with a drying time extended to approximately twenty-four hours at the oven's highest temperature. The filter paper should be dried six to twelve hours at 85°C. to 100°C.,

* Filter paper and activated clay may be obtained from the Westinghouse Sharon Plant.

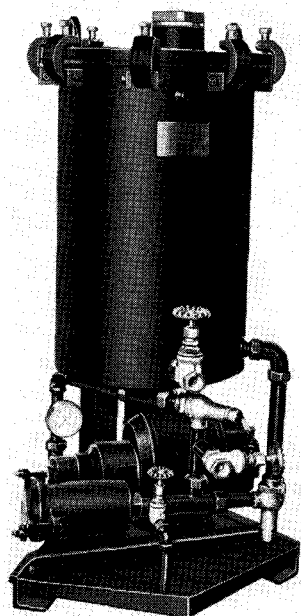

FIG. 5. Three Gallon-per-Minute Conditioner

depending on the condition of the paper and the spacing of the sheets in the oven. Both paper and clay should be placed directly in the filter after the drying process as either, if exposed, will absorb considerable moisture from the atmosphere in a very short time.

Each fresh charge of clay will absorb about three gallons of Inerteen. This should be provided for to prevent depleting the supply in the apparatus, but most of this Inerteen may be recovered when changing clay.

This can be accomplished most effectively by removing the used clay from the filter and placing it in a tank of approximately 30 gallons capacity containing about 5 gallons of water. The tank should have a drain valve at its bottom edge and should be tilted somewhat toward this valve. The clay thus placed in water, having a greater affinity for water, will give up the Inerteen it has absorbed and become saturated with water. The Inerteen being heavier than water will sink to the bottom; the clay and water will float on top. After settling for several hours, most of the Inerteen may be drawn off through the valve. This Inerteen may be reconditioned and used again in recharging the conditioner. The used clay should be discarded.

To Prepare the 7 GPM Conditioner for Operation. Remove the cover and screen from the

clay tank and fill the tank with activated clay, 4440-3, to within four inches of the bottom edge of the inner flange. Replace screen and cover. Release the pressure-screw of the filter press and loosen plates and frames. Place one sheet of "B" size blotting paper between the face of each frame and plate. Care should be used to see that the holes thru the plates, frames and paper are in proper alignment before the pressure screw is tightened. Close the discharge, tank by-pass, tank drain, suction and suction-test valves. Open the air discharge valve. Pour sufficient Inerteen into the drip pan to fill the clay tank and wet the clay. This will require approximately eight gallons of Inerteen. Start the motor and open the drip pan valve a small amount so that not less than 5 minutes are required to fill the clay tank, saturating the clay with Inerteen. (If Inerteen is admitted too rapidly, it will tend to pack the clay into the top of the tank.) With the valve at the apparatus closed, open the suction-test valve to subject the suction line to pressure and thus check it for leaks. Stop motor and close suction-test, air discharge, and drip pan valves.

To begin conditioning Inerteen in Inerteen filled apparatus, open the apparatus valves. Open the conditioner discharge and suction valves. At intervals open air discharge valve to allow trapped air to escape and close when Inerteen starts to flow through valve. Open drip pan valve at intervals too, to remove Inerteen which may have dripped into the drip pan.

When it is necessary to change the clay, first close the valve in the suction line, close the tank

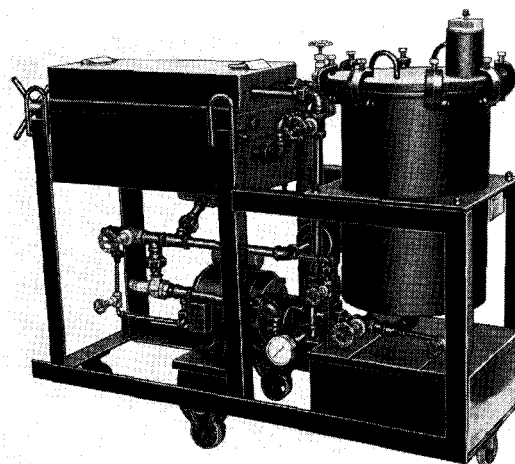

FIG. 6. Seven Gallon-per-Minute Conditioner

APPARATUS FOR RECONDITIONING

inlet and outlet valves, open the tank by-pass valve, the tank drain valve and the air vent valve to permit the free Inerteen in the tank to drain into the lower drip pan. Open the drip pan valve and pump the Inerteen from the drip pan through the filter press. Shut down the motor and remove the clay from the tank and refill with fresh clay as previously described.

To change the filter or blotting papers, stop the motor and close suction and discharge valves. Slowly back off the pressure screw, permitting the Inerteen trapped in the frames to be released gradually. Then back off the pressure screw completely, open up the press and let the surplus Inerteen drain from the papers. Replace the saturated papers with clean dry paper and retighten the press.

If the system-seal is not broken, it will only be necessary to open the discharge and suction valves and start the motor to resume conditioning the Inerteen.

To Prepare the 3 GPM Conditioner for Operation. Remove the cover and screen from the clay tank and fill the inner tank with activated clay, 4440-3, to within four inches of the top. Replace screen and cover. Close the discharge and suction valves and open air discharge and drip pan valves about $\frac{1}{3}$ open. Start motor and pour sufficient Inerteen into the drip pan to fill the clay tank and wet the clay. This will require approximately eight gallons. Not less than five minutes should be required to fill the clay tank and saturate the clay with Inerteen. With the valve at the apparatus closed, open the suction-test valve to subject the suction line to pressure and thus check it for leaks. Stop motor and close suction-test, air discharge and drip pan valves.

To begin conditioning Inerteen, open apparatus valves, open the conditioner discharge and suction valves and start motor.

At intervals open air discharge valve to let trapped air escape and close as soon as Inerteen flows from the valve.

When it is necessary to change the clay, first stop motor and close the valves in the suction and discharge lines. Remove discharge hose and open the discharge valve and tank drain valve to permit the Inerteen in the tank and discharge hose to drain into a container. After draining is complete, remove inner tank and dump the clay from the inner tank and refill with fresh clay as previously described. The used clay should be discarded.

BLOTTER FILTER PRESS

The blotter filter press (See Fig. 7) is essentially a number of sets of blotter filter papers in parallel, each set containing several thicknesses. The Inerteen is pumped through filter paper which absorbs the water and strains out the sediment.

Other Classes of Service. Although there are other uses, such as cleaning of low-viscosity insulating compounds, benzine, etc., it is recommended that a cleaning device intended for Inerteen reconditioning should not be used for other classes of work, due to danger of subsequent contamination of the Inerteen.

Capacity. The capacity of these machines, with Inerteen pressure and filtering area fixed, depends on the viscosity of the Inerteen and its freedom from dirt. With fairly clean Inerteen at ordinary room temperature, the capacity of the machines will vary from normal to about 15 percent above normal, depending on the viscosity (which varies with the temperature). It has been found that the best results are obtained when the Inerteen temperature is about 50°C. The average working pressure of these machines is less than 40 psi and the pressure relief valve is set at the factory to by-pass the full flow at from 60 psi to 80 psi.

Apparatus. There are three standard sizes of Westinghouse filter presses: B-5, B-10, and A-30. The letter designates the size of filter paper; the number indicates the relative capacity in gallons per minute.

The complete outfit consists of filterpress, motor, strainer, pump, gas trap, pressure gauge, drip pan, wheels, and piping. The piping is arranged so the line can be tested for leaks under pressure. All machines are mounted on a fabricated structural steel frame. The drip pan can be removed by disconnecting one pipe coupling and four bolts. The strainer can be cleaned by disconnecting three bolts. The pumps are of the helical-gear type to insure quietness and smooth flow of Inerteen. The A-30 pump is connected to the motor through flexible couplings. The B-5 and B-10 pumps are mounted directly on the rear motor bracket and driven through a helical reduction gear.

The filter press proper is made up of a series of cast iron plates and frames assembled alternately, with the filter papers between them. By means of a screw and cast-iron end block, the plates, frames, and papers are forced tightly together. Except for a machined rim which serves as a joint to prevent

the escape of Inerteen, the plates are cast with small pyramids on both surfaces.

The plates and frames have holes in two corners and supporting lugs at the sides. The plates have handles cast on the top edge. When the plates and frames are assembled with the filter papers between, the holes form the inlet and outlet. The frames have the holes in the upper corner connected by small ducts to the middle of the frame. The plates have ducts leading from the surface of the plate to the hole in the lower corner. (See Fig. 8)

The Inerteen enters under pressure at the top corner through the inlet formed by the holes in the frames, plates, and filter papers, flows into the frames through the same ducts, and completely fills the chamber formed by the frame and two sets of filter paper. As there are no outlet ducts in the frame, the Inerteen is forced through the paper and flows along the grooves between the rows of pyramids and out through the ducts provided at the lower corner of the plates. The dry filter paper takes up the moisture and removes the sediment from the Inerteen.

Operation. The filter press is made ready for operation by placing a set of five sheets of filter paper (that have been thoroughly dried in an electric oven) between each filter plate and frame. The holes in the filter paper must line up with the holes in the plates and frames. The sediment is strained out by the first layer of paper and the moisture is taken up by the capillary action of the paper.

If any moisture remains, it indicates that the filter papers are saturated with moisture and should be renewed. No rule can be given as to how often the papers must be changed, as this depends entirely on the condition of the Inerteen. The usual procedure is to run the machine for about half an hour (if the Inerteen is not in very bad condition) and then shut down; remove one sheet from the inlet side of each set and put in a new sheet on the outlet side of each set. (The frame is the inlet side and the plate is the outlet side.) Frequent dielectric tests should be made during this procedure as wet Inerteen may necessitate recharging the filter press with a full set of papers before the five sheets have been removed in succession.

The quickest method of filtering a quantity of Inerteen is to pump all the Inerteen through the filter and into another tank which is clean and dry. If care is taken to change the filter papers before they become saturated, the Inerteen will be clean and dry. If a second tank for holding the Inerteen

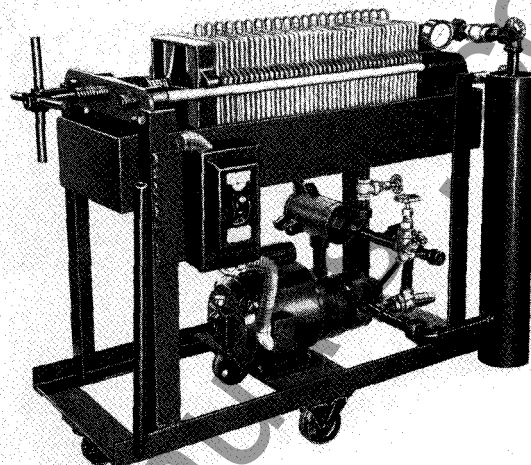

FIG. 7. B-10 Blotter Filter Press

is not available, or if it is desired to filter the Inerteen of apparatus while it is in service, the Inerteen may be pumped from the top of the apparatus tank through the filter and returned to the bottom of the same tank under the surface of the Inerteen. This operation should be continued until the Inerteen in the apparatus tank shows a sufficiently high dielectric strength.

When a large quantity of Inerteen is to be filtered, time may be saved by using two filter presses, one of which may be operated while the other is being recharged.

Filtering through blotter filter papers does not materially reduce organic acidity or improve resistance to emulsification, although the dielectric strength may be restored to a satisfactory value.

The capacity of the filter press is much reduced when operating at low temperatures.

When the Inerteen has to be filtered at low temperatures, an additional pump in the pipe line is desirable.

Inerteen in apparatus contaminated by only a small amount of moisture may be reconditioned by drawing the Inerteen from the top of the apparatus tank, passing it through the filter press, and pumping it back into the bottom of the apparatus. The Inerteen should be put through the system until a sample drawn from the top of the apparatus gives satisfactory dielectric values.

Blotter Filter Paper. The filter paper used is a special grade of blotting paper about .025 in. thick; it contains no coloring matter or chemicals which might injure the Inerteen. Five sheets cut to

APPARATUS FOR RECONDITIONING

the proper size, $12\frac{7}{8}$ in. square for the A sizes and $7\frac{3}{4}$ in. square for the B sizes, and with holes punched to correspond with the holes in the plates and frames, are used between each plate and the adjacent frames.

To obtain the best results in reconditioning Inerteen, the paper must be perfectly dry when first placed in the press. Filter paper always takes up

moisture if exposed to the air for any length of time and for this reason care must be used in handling. The standard paper is carried in packages containing one ream, carefully wrapped in waxed paper and covered with heavy wrapping paper.

Electric Drying Ovens. Electric drying ovens for use with Type A and Type B filter presses require 2000 watts and 1400 watts respectively. The interior of the ovens is provided with rods for supporting the filter paper to facilitate rapid and thorough drying. An automatic thermostat having a range of 65°C to 120°C is provided for maintaining uniform oven temperature. The thermostat is adjusted at the factory for 100°C , the recommended value, and the setting marked so that the operator may conveniently reset thermostat to 100°C if adjustment is changed.

The standard thermostat-equipped oven is suitable for alternating current only. Ovens to operate on direct current are special and are equipped with a thermometer and a manually operated three-heat switch.

By moving one rod, the Type A oven can be used for drying Type B paper.

The normal capacity of the Type A oven is 240 sheets and the Type B oven is 180 sheets when spaced $\frac{1}{4}$ inch apart.

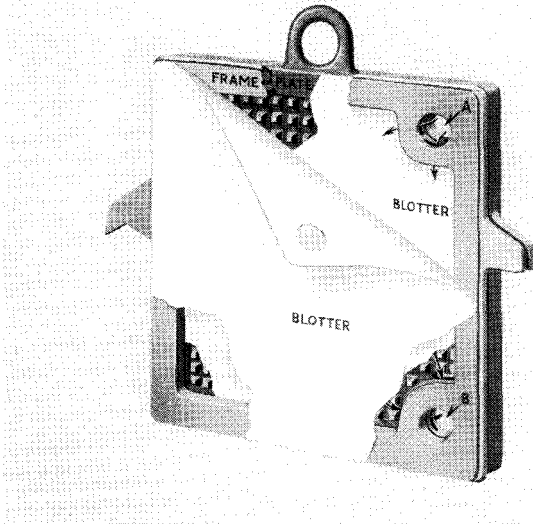

FIG. 8. Blotter Filter Press Frame Showing Blotter Filter Papers in Place

WESTINGHOUSE ELECTRIC CORPORATION

HEADQUARTERS: 401 LIBERTY AVE., P. O. BOX 2278, PITTSBURGH 30, PA.
SALES OFFICES

AKRON 8, OHIO, 106 South Main St.
ALBANY 4, N. Y., 454 No. Pearl St.
ALBUQUERQUE, N. MEX., 1115 1/2 E. Central Ave.
ALLENTOWN, PA., 739 Hamilton St.
AMARILLO, TEXAS, 503 Amarillo Bldg., 301 Polk St.
APPLETON, WIS., 321 W. College Ave., P.O. Box 206
ATLANTA 2, GA., 1299 Northside Drive, N. W., P.O. Box 4808
AUGUSTA, MAINE, 9 Bowman St.
BAKERSFIELD, CALIF., 2224 San Emidio St.
BALTIMORE 2, MD., 501 St. Paul Pl.
BEAUMONT, TEXAS, 515 American National Bank Bldg.
BIRMINGHAM 3, ALA., 1407 Comer Bldg.
BLUEFIELD, W. VA., 704 Bland St., P.O. Box 848
BOSTON 10, MASS., 10 High St.
BRIDGEPORT 8, CONN., 540 Grant St.
BUFFALO 3, N. Y., Ellicott Square Bldg.
BUTTE, MONT., 1 East Broadway
CANTON 2, OHIO, 120 W. Tuscarawas St.
CEDAR RAPIDS, IOWA, 512 Dows Bldg., P.O. Box 1828
CHARLESTON, S. C., 6 Parish Road, Moreland, P.O. Box 303
CHARLESTON 1, W. VA., 179 Summers St., P.O. Box 911
CHARLOTTE 1, N. C., 210 East Sixth St.
CHATTANOOGA 2, TENN., Volunteer State Life Bldg.
CHICAGO, ILL., Merchandise Mart Plaza
CINCINNATI 2, OHIO, 207 West Third St.
CLEVELAND 13, OHIO, 1370 Ontario St.
COLUMBIA, S. C., 3121 Pickett St.
COLUMBUS 16, OHIO, 262 N. 4th St.
CORPUS CHRISTI, TEXAS, 205 N. Chaparral St.
DALLAS 1, TEXAS, 209 Browder St.
DAVENPORT, IOWA, 2212 E. 12th St., P.O. Box 29
DAYTON 2, OHIO, 32 North Main St.
DENVER, COLO., 910 Fifteenth St.
DES MOINES 8, IOWA, 1400 Walnut St.
DETROIT 31, MICH., 5757 Trumbull Ave., P.O. Box 828
DULUTH 2, MINN., 10 East Superior St.
EL PASO, TEXAS, 718 Mills Bldg.
EMERYVILLE 8, CALIF., 5815 Peladeau St.
ERIE 2, PA., 1003 State St.
EVANSVILLE 8, IND., 106 Vine St.
FAIRMONT, W. VA., 10th and Bellline Sts., P.O. Box 1147
FERGUS FALLS, MINN., 101 1/2 W. Lincoln Ave.
FORT WAYNE 2, IND., 610 S. Harrison St.
FT. WORTH 2, TEXAS, 408 West Seventh St.
FRESNO 1, CALIF., 2608 California Ave.
GARY, IND., 846 Broadway
GRAND RAPIDS 2, MICH., 148 Monroe Ave., N.W.
GREENSBORO, N. C., 1008 Pamlico Drive, P.O. Box 3072
GREENVILLE, S. C., 160 W. Tallulah Drive, P.O. Box 1591
HAMMOND, IND., 235 Locust St.
HARTFORD 3, CONN., 119 Ann St.
HOUSTON 2, TEXAS, 1314 Texas Ave.
HUNTINGTON 1, W. VA., 1029 Seventh Ave., P.O. Box 1150
INDIANAPOLIS 9, IND., 137 S. Pennsylvania St.
JACKSON, MICH., 120 West Michigan Ave.
JACKSON, MISS., Fondren Station, P.O. Box 4296
JACKSONVILLE 6, FLA., 545 E. 4th St., P.O. Box Drawer K
JAMESTOWN, N. Y., Wellman Bldg., 101 West 3rd St.
JOHNSON CITY, N. Y., 419 Grand Ave.
JOHNSTOWN, PA., Wallace Bldg., 406-410 Main St.
KANSAS CITY 6, MO., 101 W. Eleventh St.
KINGSPORT, TENN., 145 Commerce St.
KNOXVILLE 8, TENN., Gay and Clinch Sts.
LAKE CHARLES, LA., 1622 Sixteenth St., P.O. Box 1336
LINCOLN, NEBR., 401 Federal Securities Bldg.
LITTLE ROCK, ARK., 707 Beyle Bldg., 103 W. Capitol St.

LOS ANGELES 17, CALIF., 600 St. Paul Ave.
LOUISVILLE 2, KY., 332 West Broadway
MADISON 3, WIS., 1022 E. Washington Ave.
MANSFIELD, OHIO, 246 E. Fourth St.
MEDFORD, ORE., 38 N. Bartlett St., P.O. Box 1308
MEMPHIS 3, TENN., 130 Madison Ave.
MIAMI 32, FLA., 731 Ingraham Bldg.
MILWAUKEE 2, WIS., 538 N. Broadway
MINNEAPOLIS 13, MINN., 2303 Kennedy St., N.E.
MOBILE, ALA., 171 Emogene Pl.
NASHVILLE 4, TENN., 401-6th Ave. S.
NEWARK 2, N. J., 1180 Raymond Blvd.
NEW HAVEN 8, CONN., 42 Church St., P.O. Box 1817
NEW ORLEANS 13, LA., 238 South Saratoga St.
NEW YORK 5, N. Y., 40 Wall St.
NIAGARA FALLS, N. Y., 253 Second St.
NORFOLK 10, VA., 915 W. 21st St.
OKLAHOMA CITY 2, OKLA., 120 N. Robinson St.
OMAHA 2, NEBR., 117 North Thirteenth St.
PEORIA 3, ILL., 2800 N. Adams St.
PHILADELPHIA 4, PA., 3001 Walnut St.
PHOENIX, ARIZ., 1102 N. 21st Ave., P.O. Box 6144
PITTSBURGH 30, PA., 306 4th Ave., P.O. Box 1017
PORTLAND 4, OREG., 309 S. W. Sixth Ave.
PROVIDENCE 3, R. I., 51 Empire St.
RALEIGH, N. C., 803 North Person St., P.O. Box 2146
READING, PA., 102 N. 4th St.
RICHMOND 19, VA., 1110 East Main St.
ROANOKE 4, VA., Kirk Ave. and First St.
ROCHESTER 7, N. Y., 1048 University Ave.
ROCKFORD, ILL., 323 South Main St.
RUTLAND, VT., 98 Merchants Row
SACRAMENTO 14, CALIF., 1720 14th St.
SAGINAW, MICH., 609 Peoples Building & Loan
ST. LOUIS, MO., 411 North Seventh St.
SALT LAKE CITY 1, UTAH, 235 W. South Temple St.
SAN ANTONIO 5, TEXAS, 115 W. Travis St.
SAN DIEGO 1, CALIF., 861 Sixth Ave.
SAN FRANCISCO 8, CALIF., 410 Bush St.
SEATTLE 4, WASH., 3451 East Marginal Way
SHREVEPORT, LA., 222 Spring St., P.O. Box 1202
SIOUX CITY 7, IOWA, 1005 Dace St., P.O. Box 1647
SOUTH BEND 4, IND., 216 East Wayne St.
SPARTANBURG, S. C., 331 High Point Road
SPOKANE 8, WASH., 1023 W. Riverside Ave.
SPRINGFIELD, ILL., 517 Illinois Bldg., P.O. Box 37
SPRINGFIELD 3, MASS., 26 Vernon St.
SYRACUSE 4, N. Y., 700 W. Genesee St.
TACOMA 2, WASH., 1930 Pacific Ave.
TAMPA, FLA., 608 Tampa St.
TOLEDO 4, OHIO, 245 Summit St.
TRENTON 8, N. J., 28 W. State St.
TULSA 3, OKLA., 600 S. Main St.
UTICA 1, N. Y., 113 N. Genesee St.
WALLA WALLA, WASH., Denny Bldg., P.O. Box 182
WASHINGTON 6, D. C., 1625 K St., N. W.
WA. LOO, IOWA, 300 West 3rd St.
WATERTOWN, N. Y., 245 State St.
WHEELING, W. VA., 12th and Main Sts.
WICHITA, KANS., 211 1/2 So. Main St.
WILKES-BARRE, PA., 267 N. Pennsylvania Ave.
WILLIAMSPORT, PA., 460 Market St.
WORCESTER 8, MASS., 507 Main St.
YORK, PA., 11 W. Market St.
YOUNGSTOWN 3, OHIO, 25 E. Boardman St.

MANUFACTURING AND REPAIR DEPARTMENT OFFICES

ATLANTA 2, GA., 1299 Northside Drive, N. W., P.O. Box 4808
AUGUSTA, MAINE, 9 Bowman St.
BALTIMORE 24, MD., 4015 Foster Ave.
BATON ROUGE, LA., 555 Choctaw Drive
BOSTON 27, MASS., 235 Old Colony Ave., So. Boston
BRIDGEPORT 8, CONN., 540 Grant St.
BROOKLYN 6, N. Y., 1 Harrison Place (Windsor M & R Corp.)
BUFFALO 10, N. Y., 1132 Seneca St.
CHARLOTTE 1, N. C., 210 East Sixth St.
CHICAGO 32, ILL., 3900 W. 41st St., P.O. Box 1103, Zone 90
CINCINNATI 29, OHIO, 1050 Laidlaw Ave.
CLEVELAND 2, OHIO, 5901 Breakwater Ave.
DENVER 2, COLO., 200 Rio Grande Blvd.
DETROIT 31, MICH., 5757 Trumbull Ave., P.O. Box 828
EMERYVILLE 8, CALIF., 5815 Peladeau St.
FAIRMONT, W. VA., 10th and Bellline Sts., P.O. Box 1147
FORT WORTH 7, TEXAS, 100 Rupert St., P.O. Box 1696
HILLSIDE, N. J., 1441 Chesnut Ave.
HOUSTON 20, TEXAS, 5730 Clinton Dr.

HUNTINGTON 1, W. VA., 1029 Seventh Ave., P.O. Box 1150
HUNTINGTON PARK, CALIF., 3383 E. Gage Ave., P.O. Box 629
INDIANAPOLIS 2, IND., 551 West Merrill St., P.O. Box 1535
JOHNSTOWN, PA., 107 Station St.
MILWAUKEE 3, WIS., 424 North Fourth St.
MINNEAPOLIS 13, MINN., 2303 Kennedy St., N. E.
PHILADELPHIA 34, PA., Erie Ave. & "D" St.
PHILADELPHIA 4, PA., 3001 Walnut St.
PITTSBURGH 8, PA., 543 N. Lang Ave.
PORTLAND 12, OREG., 626 North Tillamook St.
PROVIDENCE 3, R. I., 16 Elbow St.
ST. LOUIS 10, MO., 1601 S. Vandeventer Ave.
SALT LAKE CITY 1, UTAH, 235 W. South Temple St.
SEATTLE 4, WASH., 3451 East Marginal Way
SPRINGFIELD 1, MASS., 395 Liberty St.
SUNNYVALE, CALIF. (Sunnyvale Plant)
SYRACUSE 4, N. Y., 700 West Genesee St.
UTICA 1, N. Y., 113 N. Genesee St.
WILKES-BARRE, PA., 267 N. Pennsylvania Ave.

DISTRICT ENGINEERING AND SERVICE DEPARTMENT OFFICES

ATLANTA 2, GA., 1299 Northside Drive, N. W., P.O. Box 4808
BALTIMORE 2, MD., 501 St. Paul Pl.
BEAUMONT, TEXAS, 515 American National Bank Bldg.
BLUEFIELD, W. VA., 704 Bland St., P.O. 848
BOSTON 10, MASS., 10 High St.
BRIDGEPORT 8, CONN., 540 Grant St.
BUFFALO 3, N. Y., Ellicott Square Bldg.
BUTTE, MONT., 1 East Broadway
CHARLOTTE 1, N. C., 210 East Sixth St.
CHICAGO, ILL., Merchandise Mart Plaza
CINCINNATI 2, OHIO, 207 West Third St.
CLEVELAND 13, OHIO, 1370 Ontario St.
COLUMBUS 16, OHIO, 262 N. 4th St.
DALLAS 1, TEXAS, 209 Browder St.
DENVER, COLO., 910 Fifteenth St.
DES MOINES 8, IOWA, 1400 Walnut St.
DETROIT 31, MICH., 5757 Trumbull Ave., P.O. Box 828
DUL TH 2, MINN., 10 East Superior St.
EL PASO, TEXAS, 718 Mills Bldg.
GRAND RAPIDS 2, MICH., 148 Monroe Ave., N. W.
HOUSTON 2, TEXAS, 1314 Texas Ave.
HUNTINGTON 1, W. VA., 1029 Seventh Ave., P.O. Box 1150
INDIANAPOLIS 9, IND., 137 S. Pennsylvania St.
JACKSON, MICH., 120 W. Michigan Ave.
KANSAS CITY 6, MO., 101 W. Eleventh St.
LOS ANGELES 17, CALIF., 600 St. Paul Ave.
LOUISVILLE 2, KY., 332 West Broadway

MEMPHIS 3, TENN., 130 Madison Ave.
MILWAUKEE 2, WIS., 538 N. Broadway
MINNEAPOLIS 13, MINN., 2303 Kennedy St., N. E.
NEWARK 2, N. J., 1180 Raymond Blvd.
NEW ORLEANS 13, LA., 238 South Saratoga St.
NEW YORK 5, N. Y., 40 Wall St.
NORFOLK 10, VA., 915 W. 21st St.
PHILADELPHIA 4, PA., 3001 Walnut St.
PHOENIX, ARIZ., 1102 N. 21st Ave., P.O. Box 6144
PITTSBURGH 30, PA., 306 4th Ave., P.O. Box 1017
PROVIDENCE 3, R. I., 16 Elbow St.
RICHMOND 19, VA., 1110 East Main St.
ROANOKE 4, VA., Kirk Ave. and First St.
ST. LOUIS, MO., 411 North Seventh St.
SALT LAKE CITY 1, UTAH, 235 W. South Temple St.
SAN DIEGO 1, CALIF., 861 Sixth Ave.
SAN FRANCISCO 8, CALIF., 410 Bush St.
SEATTLE 4, WASH., 3451 East Marginal Way
SPOKANE 8, WASH., 1023 W. Riverside Ave.
SPRINGFIELD 3, MASS., 26 Vernon St.
SYRACUSE 4, N. Y., 700 W. Genesee St.
TOLEDO 4, OHIO, 245 Summit St.
UTICA 1, N. Y., 113 N. Genesee St.
WASHINGTON 6, D. C., 1625 K Street, N. W.
WILKES-BARRE, PA., 267 N. Pennsylvania Ave.
YOUNGSTOWN 3, OHIO, 25 E. Boardman St.

www.ElectricalPLCManuals.com



www.ElectricalPartManuals.com

www.ElectricalPartManuals.com

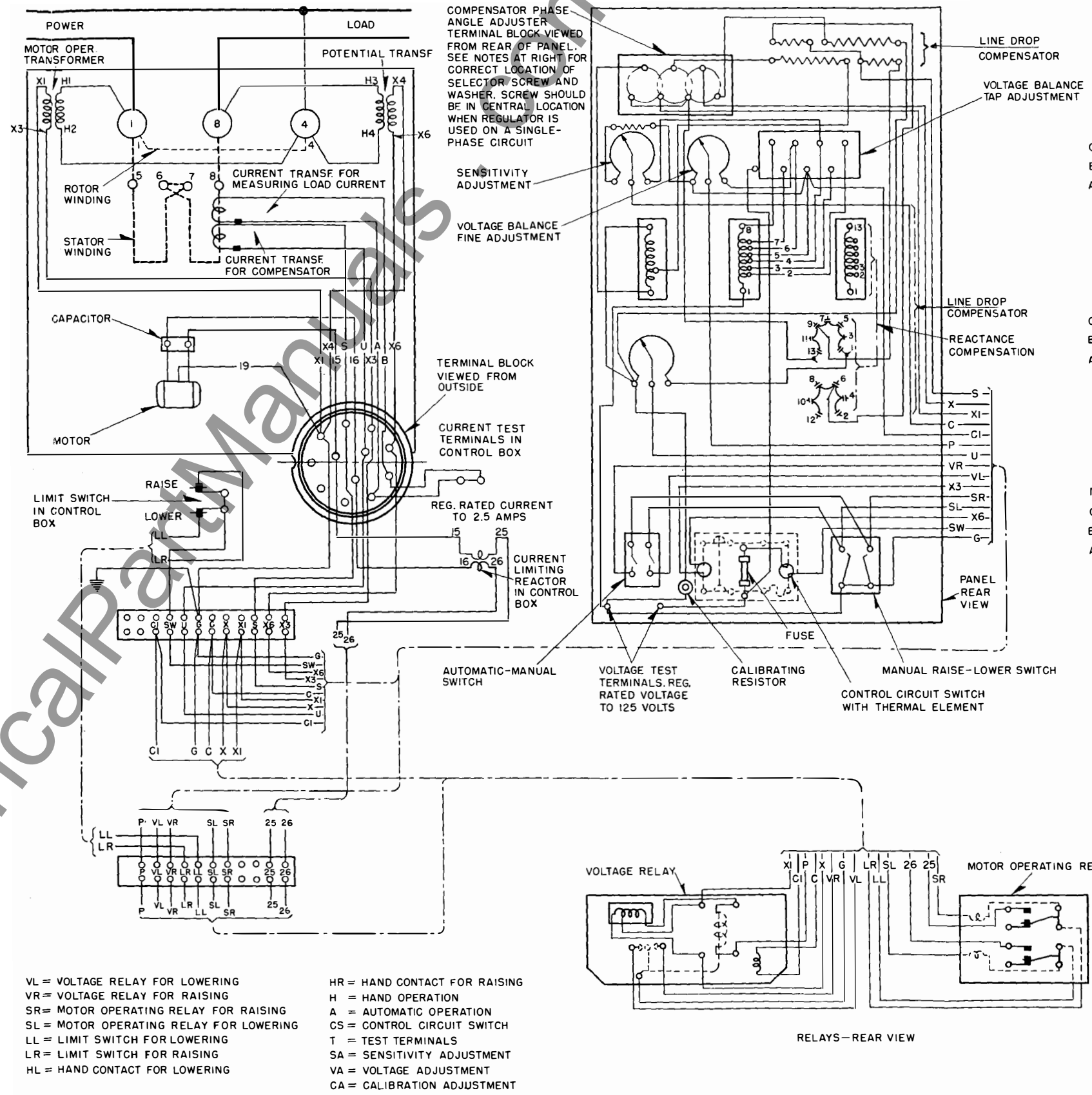

- VL = VOLTAGE RELAY FOR LOWERING
- VR = VOLTAGE RELAY FOR RAISING
- SR = MOTOR OPERATING RELAY FOR RAISING
- SL = MOTOR OPERATING RELAY FOR LOWERING
- LL = LIMIT SWITCH FOR LOWERING
- LR = LIMIT SWITCH FOR RAISING
- HL = HAND CONTACT FOR LOWERING
- HR = HAND CONTACT FOR RAISING
- H = HAND OPERATION
- A = AUTOMATIC OPERATION
- CS = CONTROL CIRCUIT SWITCH
- T = TEST TERMINALS
- SA = SENSITIVITY ADJUSTMENT
- VA = VOLTAGE ADJUSTMENT
- CA = CALIBRATION ADJUSTMENT

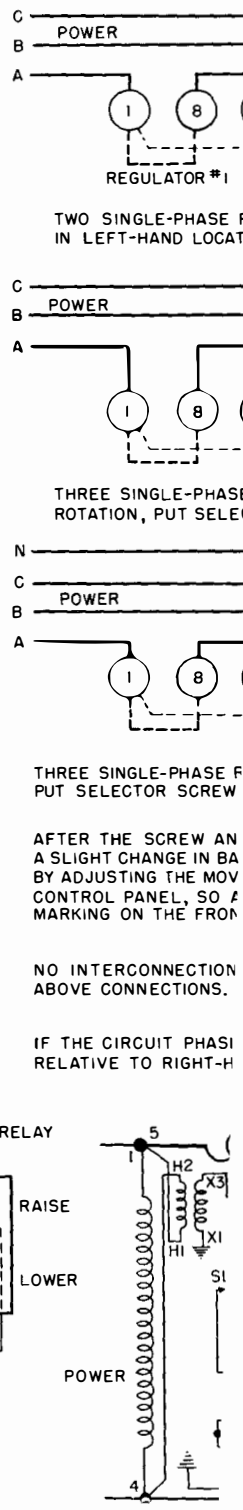
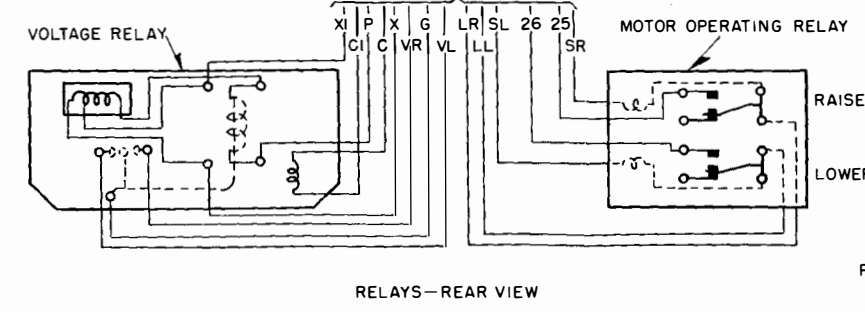

FIG. 12. W

www.ElectricalPartManuals.com