



Reduced Voltage Starters-Solid State

Introduction2-2

ASTAT®-SD

Applications, Features and Description.....2-3

Open Starters (QS2)2-4

Enclosed Noncombination Starters (CR376)2-5

Enclosed Combination Starters,
Fusible Disconnect Type (CR377)2-6

Enclosed Combination Starters,
Mag-Break Type (CR378).....2-7

Enclosed Starters, Factory Installed Modifications
(CR376, CR377, CR378).....2-8

Technical Specifications2-10

Outlines and Dimensions2-12

ASTAT®-IBP Plus

Applications, Features and Description2-13

Open Starters (Q13)2-16

Enclosed Starters (CR374, CR375).....2-17

Technical Specifications (Q13)2-21

Open Starters, Outlines and Dimensions2-25

ASTAT®-CD Plus

Applications, Features and Description2-29

Open Starters (QC2)2-32

Enclosed Noncombination Starters (CR370).....2-33

Enclosed Combination Starters,
Fusible Disconnect Type (CR371).....2-36

Enclosed Combination Starters,
Mag-Break Type (CR373).....2-38

Enclosed Starters, Factory Installed Modifications
(CR370, CR371, CR373).....2-41

Technical Specifications (QC2).....2-46

Open Starters, Outlines and Dimensions (QC2).....2-49

Enclosed Starters, Outlines and Dimensions and Weights
(CR370, CR371, CR373).....2-51

Reduced Voltage Starters-Electromechanical

Introduction.....2-53

Reduced Voltage Autotransformer Starters

Applications, Features, Description and
Product Number Selection Instructions (CR331)2-54, 2-55

Product Table (CR331).....2-56

Outlines, Dimensions and Weights (CR331)2-57

Reduced Voltage Wye Delta Starters

Applications, Features, Description and
Product Number Selection Instructions (CR332).....2-58

Product Tables (CR332)2-59

Outlines, Dimensions and Weights (CR332)2-61

Schematic Diagrams (CR332)2-62

Reduced Voltage Part Winding Starters

Applications, Features, Description and
Product Number Selection Instructions (CR330).....2-63

Product Table (CR330).....2-64

Outlines, Dimensions and Weights (CR330)2-64

Schematic Diagrams (CR330)2-65

Reduced Voltage Starters

Factory Installed Modifications (CR330, CR331, CR332).....2-66

Heaters (CR123, CR123F)2-68



Publications and Reference: See Section 17 for a complete list of additional product-related publications

Reduced Voltage Starters Solid State

ASTAT®

Solid State Reduced Voltage Starters

Introduction

GE offers multiple lines of solid state motor starters to meet the need of the most demanding applications.

ASTAT®-SD is a small, compact, solid state reduced voltage (SSRV) starter ranging from 5-25 horsepower at 460 volts. The SD offers the user greater economy without sacrificing the flexibility and capability of the soft starter.

ASTAT®-IBP Plus is a solid state reduced voltage starter which offers an integral bypass function. The line offers a fully rated bypass contactor completely wired and integrated with the SCRs to reduce size, installation time and offer flexibility. This line of SSRV has been enhanced with many new features for even greater application flexibility including monitoring, new enhanced pump control algorithm, new protective features and communications capability. The ASTAT®-IBP Plus has 2 programmable inputs and 2 programmable outputs. Ratings are available from 40-300 hp at 460 volts and 50-350 hp at 575 volts.

The ASTAT®-CD Plus is the most flexible of the GE ASTAT® lines of SSRV starters. It is available from 7 1/2 hp to 1000 hp at 460 volts. The ASTAT®-CD Plus has been enhanced with many of the same new features as found in the ASTAT®-IBP Plus. It offers DC injection breaking, slow speed (7 and 14%), reverse slow speed, energy savings, retry and 3 programmable outputs.

Application

ASTAT®-SD, ASTAT®-IBP Plus, and ASTAT®-CD Plus are used in applications requiring motor starters which provide smooth acceleration and deceleration. Among these are belted equipment, centrifuges, conveyors, cranes, fans/blowers, hoists, machine tools, packaging equipment, pumps, textile machinery, winches, and wire drawing machines.

ASTAT® solid state reduced voltage starters offer much greater flexibility than conventional RV starters and more value in terms of ease of use and precision of performance.



ASTAT®-SD Solid State Reduced Voltage Starter

Product Features

	SD	IBP Plus	CD Plus
Adjustable current limit & starting torque	X	X	X
Digital display		X	X
Monitoring (volts, amps, kw, pf)		X	X
Elapsed time meter		X	X
Soft Start/Stop	X	X	X
Start/Stop Pump Control		X	X
Fault Diagnostics	X	X	X
Error Tracing		X	X
Built-in overload		10, 20, 30	10, 20, 30
Kick Start	X	X	X
DC Injection Brake			X
Slow Speed (7 & 14%)			X
Reverse Slow Speed (20%)			X
Retry			X
Programmable Inputs		2	2
Programmable Outputs		2	3
Dual Motor Control		X	X
Under/Over voltage Protection		X	X
Under/Over current Protection	X		X
Energy Saving Mode	X		X
Communications		X	X
Voltage	200-460V	200-600V	200-460V
CE Mark	X		X
UL, C-UL	X	X	X

Standards and listings

UL 508, File E 153901
cUL Listed
IEC 947-4-2

Reference Publications

DEH-036	ASTAT®-SD Instruction
DEH-40396	ASTAT®-IBP CD Plus User Manual
DEH-40417	ASTAT®-IBP CD Plus Service Instruction
DEH-40397	ASTAT®-CD Plus User Manual
DEH-40418	ASTAT®-CD Plus Service Instruction

Reduced Voltage Starters

Solid State

ASTAT®-SD®

Description

ASTAT®-SD® solid state reduced voltage starters bring more performance, economy, and simplicity to your application. Compared to starters relying on analog circuits, ASTAT®-SD starters use digital technology to enhance precision and performance. Compared to other starters in their class, they offer the best combination of features and flexibility.

Power wiring is brought to the top saddle clamp type terminals, which carry dual labeling of 1L1, 3L2, 5L3. The load terminals at the bottom—marked 2T1, 4T2, 6T3—accept the C-2000™ RT1 type overload relay. This overload mounts easily by using the overload hook and tightening the ASTAT®-SD's load terminals. All terminals, including control and control power terminals, are finger-safe and back-of-hand protected to meet the requirements of the US and IEC markets.

Set-up is as easy as setting the time and percent of current limit or initial torque. Just select the type of operation with the DIP switches and set the ramp time and initial current/torque setting with two potentiometer controls. All controls and status displays are visible through a clear plastic window on the front of the starter. Status indication is similarly simple. Four LEDs show the operational status of the starter and blinking LEDs differentiate 10 distinct errors.

Control power may be either 120V or 240V, 50/60 Hz. The ASTAT®-SD requires only 2 watts to power the electronics, adding very little burden to existing CPTs. Starting and stopping is easily accomplished with either 2-wire control through a simple contact closure/opening or 3-wire control for push button application using only the push button contacts. For applications where long wire runs may induce false signals, an interposing relay may be added to the control circuit. A standard programmable relay allows remote indication of run condition. It may be programmed for end of ramp (at speed) to allow control of other operations once the motor is up to speed.

The ASTAT®-SD is UL and cUL listed, complies with the European EMC and Low Voltage directives, and is supplied with the CE mark. Declarations of Conformity are available.

Application

ASTAT®-SD starters are used to control motors to smoothly accelerate and decelerate loads. They reduce or eliminate mechanical shock and stress on mechanical components such as V-belts, gear boxes, chain drives, couplings, transmissions and shafts. They also reduce brownout conditions and may limit energy and demand charges. An energy-saving feature may be selected for lightly loaded motors. Typical applications include:

- belted equipment
- centrifuges
- compressors
- conveyors
- cranes
- crushers
- extruders
- fans/blowers
- flywheels
- hoists
- laundry extractors
- machine tools
- mixers
- packaging equipment
- pumps
- saws
- shears
- spinning frames
- textile machinery
- winches
- winders
- wire drawing machines

Standard Features

An array of features let you match equipment capabilities to application needs. This includes motor starting with a voltage ramp or current limit to fit acceleration to the load and power supply as well as soft stop. Indicators accelerate fault-tracing and reduce downtime. Troubleshooting is easy with a display that shows run functions and indicates diagnostics when fault conditions occur. Surface-mount printed circuit components reduce susceptibility to vibration and heat, so you get greater reliability.

- Soft start** provides smooth, stepless acceleration of loads with a voltage ramp adjustable from 0.5 to 60 seconds.
- Adjustable initial torque** adapts to loads by allowing settings of 15% to 80% of normal motor starting torque.
- Current limit** adjusts limit from 200% to 500% of the starter rating. This is useful in applications where peak current is critical for reducing brownout conditions or for keeping voltage-sensitive equipment on-line during motor starting.
- Kick start** boosts initial voltage to loads that pose difficult starting conditions. To break away loads with high initial friction, the motor receives a 400ms 90% voltage surge before initiating the voltage limit.
- Override mode** applies full voltage to the load during the running phase. Harmonic content voltage wave is negligible because the SCRs are fully phased forward (on) during this stage.
- Energy-saving mode**, when used during low loading levels for an extended time, improves efficiency. Once the load is reapplied, ASTAT®-SD starters respond by increasing voltage to normal.

This feature is suitable when motors are carrying less than 25% of the motor rating.

- Soft stop** provides a linear voltage decline from full voltage to zero over a period twice that of the initial time ramp. This prevents sudden stops that may disrupt processes by spilling or tumbling products on a packaging or conveyor line.
 - Coast-to-rest** results in a quicker stop than soft stop, as it opens voltage to the motor and the system forces stop the load.
- PLUS:
- 120V or 240V control voltage operation, using only two watts of power for circuit operation
 - Standard output relay, DIP switch selectable relay function for either run or end-of-ramp (at speed)
 - Stop/start circuit operates with dry contact closure with a 12V signal supplied by the soft starter and may be used for either 2- or 3-wire control
 - Offers 200V, 208V, 240V, 277V, 380V, 415V, 460V, or 500V (50/60 Hz, 3-phase) power circuits
 - Checks frequency and, if within 48-62 Hz, starts motor. Phase loss prevents motor starting and shuts down running motors after three seconds
 - Overload protection provided by standard C-2000™ Class 10 overload relay



Publications and Reference: See Section 17 for a complete list of additional product-related publications

Reduced Voltage Starters Solid State

ASTAT®-SD®

Open Starters
3-25 Hp @ 460V
Three-Phase
50/60 Hertz

ASTAT®-SD solid state reduced voltage starters (also referred to as soft starters) are supplied with back-to-back SCRs rated at 1600 PIV for optimum performance and reliability. They provide smooth, stepless acceleration and deceleration for three phase squirrel-cage induction motors over an adjustable time period. Current limit may be selected as an alternative to the voltage ramp during the acceleration phase. ASTAT®-SD starters have four LED indicators for run status and fault indication.

ASTAT®-SD starters come with 120/240 volt control power input and run/end of ramp relay output. Line input and output terminals are pressure-clamp type terminal suited for two copper wires from #14 to #8 AWG.

- UL 508, File E 153901
- cUL Listed
- IEC 947-4-2

Three-Phase

Current Rating Amps (AC-3) ¹	Max. Nominal Current for 30 sec.	Motor Horsepower @ 200V	Motor Horsepower @ 230V	Motor Horsepower @ 460V	KW 1.0 S.F. 380V/415V	Product Number ²	List Price GO-10A7	Approx. Weight (lbs.)
5	450%	1	1	3	2.2	QS2BNA	\$500.00	6
9	450%	2	2	5	4	QS2DNA	\$525.00	6
12	450%	3	3	7.5	5.5	QS2FNA	\$560.00	7
16	450%	3	5	10	7.5	QS2GNA	\$600.00	7
22	450%	5	7.5	15	10	QS2HNA	\$740.00	8
34	450%	7.5	10	20	15	QS2INA	\$775.00	10
34	300%	10	10	25	15	QS2INA	\$775.00	10

¹When operating motors at service factor loads, service factor amps must not exceed starter rated amps.

²Standard C-2000™ overload relays (types RT1) may be purchased separately and mounted directly to the starter for motor overload protection.

Reduced Voltage Starters Solid State

CR376

ASTAT®-SD®

Enclosed

Non-combination Starters

3-25 Hp @ 460V

Three-Phase

50/60 Hertz

List price includes starter in enclosure selected. Starters for 200, 230, and 460 volt motors are suitable for 120 volt separate input control power, control circuit fusing included. Order overload relay separately or, for factory-installed modifications, see page 2-8.

Enclosed starters rated for 40°C ambient. For higher ambient temperatures, derate rated starter current by 1.5%/°C above 40°C, up to a maximum of 50°C.

Three-Phase

Motor Voltage	Current Rating Amps (AC-3) ¹	Max. Nominal Current for 30 sec.	Motor Horsepower	NEMA Type 1			NEMA Type 12/3R		
				Product Number CR	List Price GO-10A7	Approx. Weight (lbs.)	Product Number CR	List Price GO-10A7	Approx. Weight (lbs.)
200 V	5	450%	1	376B121	\$596.00	35	376B221	\$704.00	42
200 V	9	450%	2	376D121	\$621.00	35	376D221	\$729.00	42
200 V	12	450%	3	376F121	\$656.00	36	376F221	\$764.00	43
200 V	16	450%	3	376G121	\$696.00	36	376G221	\$804.00	43
200 V	22	450%	5	376H121	\$908.00	37	376H221	\$1028.00	44
200 V	34	450%	7.5	376I121	\$943.00	39	376I221 ²	\$1063.00	46
200 V	34	300%	10	376I121	\$943.00	39	-	-	-
230 V	5	450%	1	376B131	\$596.00	35	376B231	\$704.00	42
230 V	9	450%	2	376D131	\$621.00	35	376D231	\$729.00	42
230 V	12	450%	3	376F131	\$656.00	36	376F231	\$764.00	43
230 V	16	450%	5	376G131	\$696.00	36	376G231	\$804.00	43
230 V	22	450%	7.5	376H131	\$908.00	37	376H231	\$1028.00	44
230 V	34	450%	10	376I131	\$943.00	39	376I231 ²	\$1063.00	46
230 V	34	300%	10	376I131	\$943.00	39	-	-	-
460 V	5	450%	3	376B141	\$596.00	35	376B241	\$704.00	42
460 V	9	450%	5	376D141	\$621.00	35	376D241	\$729.00	42
460 V	12	450%	7.5	376F141	\$656.00	36	376F241	\$764.00	43
460 V	16	450%	10	376G141	\$696.00	36	376G241	\$804.00	43
460 V	22	450%	15	376H141	\$908.00	37	376H241	\$1028.00	44
460 V	34	450%	20	376I141	\$943.00	39	376I241 ²	\$1063.00	46
460 V	34	300%	25	376I141	\$943.00	39	-	-	-

¹When operating motors at service factor loads, service factor amps must not exceed starter rated amps.

²27 amps max (SF 1.0)



Publications and Reference: See Section 17 for a complete list of additional product-related publications

Reduced Voltage Starters

Section 2

Solid State

CR377

ASTAT®-SD®

Enclosed

Combination Starters

Fusible Disconnect Type

Lists price includes ASTAT®-SD solid state reduced voltage starter, in the enclosure selected, with a fusible disconnect switch operated by a side-mounted handle that indicates status as ON in the up position and OFF in the down position. The operating handle prevents entrance into the enclosure when the switch is in the ON position, unless the defeater mechanism is deliberately operated. The handle accepts up to 3 padlocks for securing the switch in the OFF position for maintenance shutdown. Provisions also are made

for padlocking the handle in the ON position for continuous process applications requiring supervised shutdown. Starters for 200, 230, and 460 volt motors are suitable for 120 volt separate input power control and control circuit fusing included. Order over-load relay separately or, for factory-installed modifications, see page 2-8. Enclosed starters rated for 40°C ambient. For higher ambient temperatures, derate rated starter current by 1.5%/°C above 40°C, up to a maximum of 50°C.

Three-Phase

Motor Voltage	Current Rating Amps (AC-3) ¹	Max. Nominal Current for 30 sec.	Motor Horsepower	Class J Fuse Clip Size	NEMA Type 1			NEMA Type 12/3R		
					Product Number CR	List Price GO-10A7	Approx. Weight (lbs.)	Product Number CR	List Price GO-10A7	Approx. Weight (lbs.)
200 V	5	450%	1	30	377B121B	\$1250.00	50	377B221B	\$1425.00	60
200 V	9	450%	2	30	377D121B	\$1275.00	50	377D221B	\$1450.00	60
200 V	12	450%	3	30	377F121B	\$1310.00	51	377F221B	\$1485.00	61
200 V	16	450%	3	30	377G121B	\$1350.00	51	377G221B	\$1525.00	61
200 V	22	450%	5	30	377H121B	\$1633.00	52	377H221B	\$1828.00	62
200 V	34	450%	10	60	377I121C	\$1680.00	55	377I221C ²	\$1875.00	65
200 V	34	300%	7.5	60	377I121C	\$1680.00	55	-	-	-
230 V	5	450%	1	30	377B131B	\$1250.00	50	377B231B	\$1425.00	60
230 V	9	450%	2	30	377D131B	\$1275.00	50	377D231B	\$1450.00	60
230 V	12	450%	3	30	377F131B	\$1310.00	51	377F231B	\$1485.00	61
230 V	16	450%	5	30	377G131B	\$1350.00	51	377G231B	\$1525.00	61
230 V	22	450%	7.5	30	377H131B	\$1633.00	52	377H231B	\$1828.00	62
230 V	34	450%	10	60	377I131C	\$1680.00	55	377I231C ²	\$1875.00	65
230 V	34	300%	10	60	377I131C	\$1680.00	55	-	-	-
460 V	5	450%	3	30	377B141B	\$1250.00	50	377B241B	\$1425.00	60
460 V	9	450%	5	30	377D141B	\$1275.00	50	377D241B	\$1450.00	60
460 V	12	450%	7.5	30	377F141B	\$1310.00	51	377F241B	\$1485.00	61
460 V	16	450%	10	30	377G141B	\$1350.00	51	377G241B	\$1525.00	61
460 V	22	450%	15	30	377H141B	\$1633.00	52	377H241B	\$1828.00	62
460 V	34	450%	20	60	377I141C	\$1680.00	55	377I241C ²	\$1875.00	65
460 V	34	300%	25	60	377I141C	\$1680.00	55	-	-	-

¹When operating motors at service factor loads, service factor amps must not exceed starter rated amps.

²27 amps max (SF 1.0)

Reduced Voltage Starters Solid State

CR378

ASTAT®-SD®

Enclosed

Combination

Mag-Break Type®

Lists price includes ASTAT®-SD solid state reduced voltage starter, in the enclosure selected, with a Type TEC circuit breaker operated by a side-mounted handle that indicates status as ON in the up position and OFF in the down position. The operating handle prevents entrance into the enclosure when the switch is in the ON position, unless the defeater mechanism is deliberately operated. The handle accepts up to 3 padlocks for securing the switch in the OFF position for maintenance shutdown. Provisions also are made

for padlocking the handle in the ON position for continuous process applications requiring supervised shutdown. Starters for 200, 230, and 460 volt motors are suitable for 120 volt separate input power control and control circuit fusing included. Order over-load relay separately or, for factory-installed modifications, see page 2-8. Enclosed starters rated for 40°C ambient. For higher ambient temperatures, derate rated starter current by 1.5%/°C above 40°C, up to a maximum of 50°C.

Three-Phase

Motor Voltage	Current Rating Amps (AC-3) ¹	Max. Nominal Current for 30 sec.	Motor Horsepower	Circuit Interrupter Rating Amps	NEMA Type 1			NEMA Type 12/3R		
					Product Number CR	List Price GO-10A7	Approx. Weight (lbs.)	Product Number CR	List Price GO-10A7	Approx. Weight (lbs.)
200 V	5	450%	1	7	378B121C	\$1328.00	50	378B221C	\$1503.00	60
200 V	9	450%	2	7	378D121C	\$1353.00	50	378D221C	\$1528.00	60
200 V	12	450%	3	15	378F121D	\$1388.00	51	378F221D	\$1563.00	61
200 V	16	450%	3	15	378G121D	\$1428.00	51	378G221D	\$1603.00	61
200 V	22	450%	5	30	378H121E	\$1732.00	52	378H221E	\$1908.00	62
200 V	34	450%	7.5	30	378I121E	\$1768.00	55	378I221E ¹	\$1963.00	65
200 V	34	300%	10	30	378J121E	\$1768.00	55	-	-	-
230 V	5	450%	1	7	378B131C	\$1328.00	50	378B231C	\$1503.00	60
230 V	9	450%	2	7	378D131C	\$1353.00	50	378D231C	\$1528.00	60
230 V	12	450%	3	15	378F131D	\$1388.00	51	378F231D	\$1563.00	61
230 V	16	450%	5	15	378G131D	\$1428.00	51	378G231D	\$1603.00	61
230 V	22	450%	7.5	30	378H131E	\$1732.00	52	378H231E	\$1908.00	62
230 V	34	450%	10	30	378I131E	\$1768.00	55	378I231E ¹	\$1963.00	65
230 V	34	300%	10	30	378J131E	\$1768.00	55	-	-	-
460 V	5	450%	3	7	378B141C	\$1328.00	50	378B241C	\$1503.00	60
460 V	9	450%	5	7	378D141C	\$1353.00	50	378D241C	\$1528.00	60
460 V	12	450%	7.5	15	378F141D	\$1388.00	51	378F241D	\$1563.00	61
460 V	16	450%	10	15	378G141D	\$1428.00	51	378G241D	\$1603.00	61
460 V	22	450%	15	30	378H141E	\$1732.00	52	378H241E	\$1908.00	62
460 V	34	450%	20	30	378I141E	\$1768.00	55	378I241E ¹	\$1963.00	65
460 V	34	300%	25	30	378J141E	\$1768.00	55	-	-	-

¹When operating motors at service factor loads, service factor amps must not exceed starter rated amps.
²27 amps max (SF 1.0)



Publications and Reference: See Section 17 for a complete list of additional product-related publications

Reduced Voltage Starters

Section 2

Solid State

CR376, CR377, CR378

ASTAT®-SD®

Enclosed

Factory Installed Modifications

Use this section to select starters with factory-installed modifications to basic enclosed starters. Follow the steps to arrive at the product numbers and list prices for starters with selected modifications. First, select your basic enclosed starter from pages 2-4 to 2-7. Fill in the digits of the product number selected in the appropriate boxes of the **base unit product number** line below and enter the base list price in the appropriate price box. Then, to select additional modifications, follow the step-by-step instructions (see example provided). As instructed, transfer the resulting

product number digits to the **new product number digits** line and the price component for your selection to the appropriate price boxes. (Make copies of this blank form for future use).

When you're done, your complete product number will be your modified product number, with all digits from the **new product number digits** line replacing or adding to the original digits. Your total list price, GO-10A7, will be the sum of the amounts in the boxes in the price line.

Product Number

	If no other options are required, complete only Steps 1-2 (or Step 1 for noncomb. starters)							Omit this digit for noncomb. starters	Complete Steps 3-6 when further options are required.				
	1							2	3	4	5	6	
Base unit product number	C	R	3	7									
New product number digits													
	Starter Type		Frame Size			Enclosure Type	Line Volts	Control Circuit Options	Fuse and Circuit Breaker Ratings	Contactors Options	Separate Overload	Pilot Device Options	Auxiliary Contacts and Relays

Price	1	2	3	4	5	6	
\$			0				= \$
Base Price from Product Table	Omit for noncomb. starters						Total List Price, GO-10A7

Example

ASTAT®-SD solid state reduced voltage starter for a 10 Hp, 460 volt motor (12.0 motor FLA). Fused disconnect combination starter in NEMA Type 1 enclosure with CPT, START/STOP push button red RUN light.

Select base unit from table on pages 2-6 to 2-7. Enter product number CR377G141B and **\$1350.00 base price** in spaces provided.

- 1 Select CPT. Change digit in product number box 1 from 1 to 2 and enter **\$160.00** list price adder in price box 1.
- 2 No change.
- 3 No isolation contactor required. Enter 0 in product number box 3 and **\$0** in price box 3.
- 4 Select overload relay product number digit based on frame size and motor full load amps. Enter N in product number box 4 and **\$55.00** list price adder in price box 4.
- 5 Select pilot device option with START/STOP push button and red RUN light. Enter G in product number box 5 and **\$215.00** list price adder in price box 5.
- 6 No additional relay required. Enter 0 in product number box 6 and **\$0** in price box 6.

Product Number

	If no other options are required, complete only Steps 1-2 (or Step 1 for noncomb. starters)							Omit this digit for noncomb. starters	Complete Steps 3-6 when further options are required.					
	1							2	3	4	5	6		
Base unit product number	C	R	3	7	7	G	1	4	1	B				
New product number digits									2		0	N	G	0
	Starter Type		Frame Size			Enclosure Type	Line Volts	Control Circuit Options	Fuse and Circuit Breaker Ratings	Contactors Options	Separate Overload	Pilot Device Options	Auxiliary Contacts and Relays	

Price	1	2	3	4	5	6	
\$	1350.00	160.00	0	0	55.00	215.00	= \$
Base Price from Pages 2-4 to 2-7	Omit for noncomb. starters						Total List Price, GO-10A7

Assemble new, complete product number: CR377G142B0NG0. Total list price is **\$1780.00, GO-10A7**.

Reduced Voltage Starters Solid State

CR376, CR377, CR378

ASTAT®-SD®

Enclosed

Factory Installed Modifications

1 Select Control Circuit Options

Select control circuit options by frame size. Transfer the product number digit to box 1 in the "new product number digits" line and the list price adder to box 1 in the price line.

Frame Size	Product No. Digit	Control Circuit	List Price Adder, GO-10A7
B-I	0	Control voltage from power lines L1 & L2 (240V only)	—
	1	120V separate control	—
	2	CPT standard capacity (50 VA)	\$160.00

2 Fuse and Circuit Breaker Ratings Reference Table

For reference only. For combination starters, the product number digit is included in the number brought forward from the general selection tables on pages 2-4 to 2-7. For noncombination starters, skip this step and omit the corresponding digit in your product number. For all enclosed starters, if no further factory-installed modifications are desired, you may stop after this step and you will have built a valid and complete product number and list price.

Product No. Digit	Combination, Fusible Disconnect (CR377)		Combination, Mag-Break Circuit Breaker (CR378)	
	Frame Size	Class J Fuse/Fuse Clip Rating (Amps)	Frame Size	Circuit Breaker Rating (Amps)
A	B-I	unfused	—	—
B	B-H	30	—	—
C	I	60	B-F	7
D	—	—	F-G	15
E	—	—	H-I	30
F	—	—	I	50

3 Select Isolation Contactor

Select the isolation contactor applicable to your frame size. Transfer the product number digit to box 3 in the "new product number digits" line and the list price adder to box 3 in the price line.

Product No. Digit	Isolation Contactor	Frame Size	List Price Adder, GO-10A7
0	No	B-I	—
		B-D	\$115.00
		F-G	\$145.00
1	Yes	H	\$164.00
		I	\$183.00

4 Select Overload Relay

Select the overload relay from among those applicable to your frame size. Transfer the product number digit to box 4 in the "new product number digits" line and the list price adder to box 4 in the price line.

Product No. Digit	Motor Full Load Ampere Range	Applicability by Size						List Price Adder, GO-10A7
		B	D	F	G	H	I	
A	None	No overload						—
F	.65-1.1	•	•	•	•	•	•	\$55.00
G	1-1.5	•	•	•	•	•	•	\$55.00
H	1.3-1.9	•	•	•	•	•	•	\$55.00
J	1.8-2.7	•	•	•	•	•	•	\$55.00
K	2.5-4.1	•	•	•	•	•	•	\$55.00
L	4-6.3	•	•	•	•	•	•	\$55.00
M	5.5-8.5	•	•	•	•	•	•	\$55.00
N	8-12	•	•	•	•	•	•	\$55.00
P	10-16				•	•	•	\$55.00
S	14.5-18					•	•	\$55.00
T	17.5-22					•	•	\$55.00
U	21-26						•	\$55.00
V	25-32						•	\$55.00
W	30-40						•	\$55.00

5 Select Pilot Device Options

Select pilot device options. Transfer the product number digit to box 5 in the "new product number digits" line and the list price adder to box 5 in the price line.

Product No. Digit	START/STOP Push Button	H-O-A Selector Switch	Red Light	Green Light	List Price Adder, GO-10A7
A		None			—
B	•				\$130.00
C		•			\$115.00
D			RUN		\$85.00
E				RUN	\$85.00
G	•		RUN		\$215.00
H	•			RUN	\$215.00
J		•	RUN		\$200.00
K		•		RUN	\$200.00
L	•		RUN	OFF	\$255.00
M		•	RUN	OFF	\$240.00
N	START only	•			\$180.00
R	START only	•	RUN		\$265.00
S	START only	•		OFF	\$265.00
T	START only	•	RUN	OFF	\$350.00

6 Auxiliary Contacts and Relays (1NO-1NC standard)

Select auxiliary contacts and relays. Transfer the product number digit to box 6 in the "new product number digits" line and the list price adder to box 6 in the price line.

Product No. Digit	Extra Relays	3NO-1NC	2NO-2NC	1NO-3NC	List Price Adder, GO-10A7
0		None			—
1	1	•			\$62.00
2	1		•		\$62.00
3	1			•	\$62.00



Publications and Reference: See Section 17 for a complete list of additional product-related publications

Reduced Voltage Starters Solid State

ASTAT®-SD®

Technical Specifications

Section 2

Environmental

Operation Temperature	0 to 45°C ¹
Storage Temperature	-20 to + 70°C
Relative Humidity	95% without condensation
Maximum Altitude	3300 feet (1000m) ²
Mounting Position	Vertical

Electrical Characteristics

Three-phase Supply Voltage	500VAC + 10% maximum
Frequency	48-62 Hz
Rated Current	6 ratings, 5-34A
Motor Horsepower	3-25hp at 460V (3-20 kW at 500V)
Motor Voltages	200 V, 230 V, 460 V (220 V, 380/415 V, 440 V, 500 V for IEC)
Control Voltages	110/120 VAC or 220/240 VAC, 50/60 Hz

Control Characteristics

Control System	Digital system with microcontroller Starting ramp with progressive increase in voltage and current limitation
Loss of Control Voltage	Three-cycle ride-through
Initial (Starting) Torque	15 to 80% full voltage starting torque
Kick Start	90% line voltage (80% full voltage starting torque), 400ms
Current Limit	Adjustable from 200 to 500% starter rating
Acceleration Ramp Time	.5 to 60 sec. ³
Energy Savings	Output voltage reduction based on power factor of running motor to optimize system energy consumption
Override-Energy Savings	Energy saving mode turned OFF
Coasting	With no soft stop, power removed from motor
Stop Time by Ramp	Soft stop time fixed at 2 x t _{ramp}

Inputs/Outputs

Starter Control	Start/Stop or remote contact
Inputs	2 isolated inputs for Start/Stop
Input Ratings	12 VDC supplied by ASTAT® to solid state optoisolators
Output Auxiliary Relays	Run/End of Ramp (at speed), DIP switch selectable
Relay Output Ratings	5A maximum 120 VAC 360 VA pilot-duty B300 & 1/3Hp 45LRA 7.2FLA 240 VAC 470 VA pilot-duty B300 & 1/2Hp 30LRA 5.0FLA General-purpose dc ratings: 24 VDC 8A 48 VDC 0.8A 240 VDC 0.1A

Protections

Current Limit	Adjustable from 200 to 500% starter rating
Loss on Input Phase	Trip at 3 sec
Thyristor Short Circuit	Trip at 200ms
Loss on Output Phase	Trip at 3 sec
Supply Frequency Error	If frequency < 48Hz or > 62Hz, will not start
Error (CPU)	60ms
Overload Protection	Separate overload relay required

Description of Terminals

1L1, 3L2, 5L3	Power supply inputs
2T1, 4T2, 6T3	Outputs to motor
A1/A2, B1/B2	Command supply inputs (110/120-220/240 VAC), + 10%, - 15%
11, 14	Run/End of ramp internal relay output (1NO)
1, 57	Run command input
2, 57	Stop command input
3, 4	Not used

Features

SCR repetitive peak inverse voltage (PIV)	1600V
Transient protection—metal oxide varistors	QC2B through QC21; 120 joules

Standards and Listings

UL 508, File E 153901 (open), 100757 (enclosed)
cUL Listed
IEC 947-4-2 (C)
In conformity with EN500B-1, EN500B-2, EN 53001, EN 60801-2, ENV 50140, EN 61000-4-4, EN 610004-5 Complies with Electromagnetic Compatibility Directives 89/336/EEC 5/3/89 modified by 92/31EEC 4/23/92 and 93/68/EEC 7/22/93

1. Reduced rated controller current (I_r) by 1.5%°C above 45°C, maximum 55°C
2. Reduced rated controller current (I_r) by 1%/330 feet above 3300 feet, maximum 10,000 feet (1%/100m above 1000m, 3000m maximum)
3. See page 2-11 for start time limitations

Reduced Voltage Starters Solid State

ASTAT®-SD®

Technical Specifications

Operating Modes

Initial ramp	① 5 main frequency cycles
Initial voltage (pedestal)	①a 40%-90% V (adjustable by torque setting)
Kick start	② 90% V (DIP switch selectable)
Acceleration ramp (t_{ramp})	③ 0.5 to 60 seconds (adjustable)
	③a Fast ramp (if motor is up to speed prior to end of normal ramp time)
Current limit	④ 2 to 5 I _n
Permanent state choice	⑤ Nominal voltage (override)
	⑥a Nominal current
	⑥ Energy savings
Stop mode	⑦ Motor power cutoff (stopped by inertia)
	⑧ Deceleration ramp (Max. time $2 \times 1 t_{ramp}$)
	⑧a Evolution of current in deceleration ramp mode

Starting by Voltage Ramp

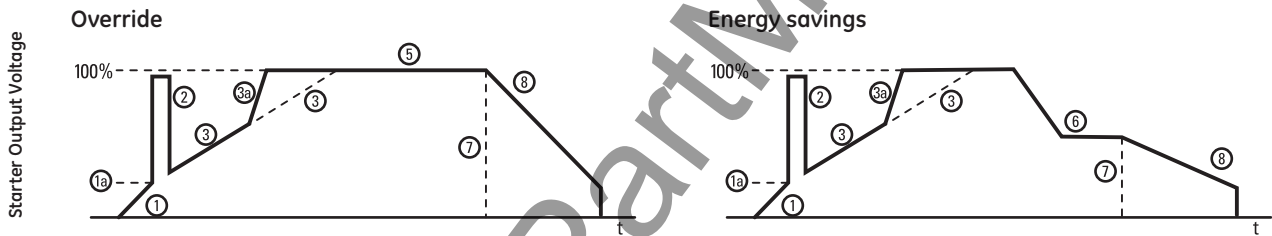

Starting by Current Limitation

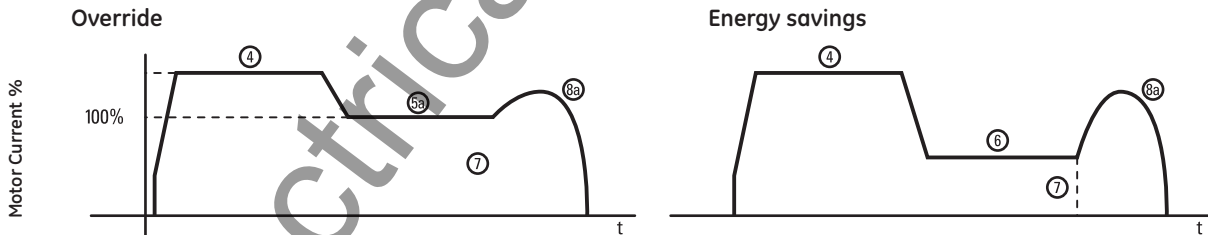

Maximum Starting Time

$\frac{I_s}{I_r}$	For Standard-Duty HP rating	For Heavy-Duty HP rating
500%	1 sec.	3 sec.
450%	5 sec.	30 sec.
300%	20 sec.	55 sec.
200%	60 sec.	60 sec.

Operating Modes



Publications and Reference: See Section 17 for a complete list of additional product-related publications

Reduced Voltage Starters Solid State

ASTAT®-SD®

Outlines and Dimensions in. (mm) (For Estimating Only)

Section 2

Open Starters

Product Number	Dimension A
QS2BNA	5.91 (150)
QS2DNA	5.91 (150)
QS2FNA	7.09 (180)
QS2GNA	7.09 (180)

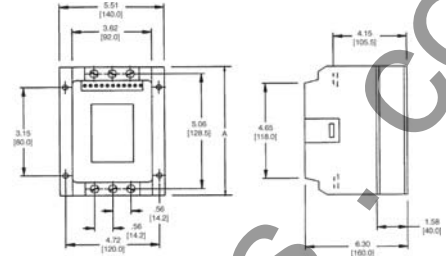

Open Starters

Open Starters

Product Number	Dimension B
QS2HNA	7.87 (200)
QS2INA	9.84 (250)

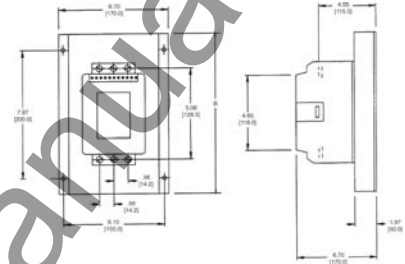

Open Starters

Enclosed Noncombination Starters, NEMA Type 1

	Dimension A	Dimension B	Dimension C	Dimension D	Dimension E	Dimension F
All	18.0 (458)	11.0 (279)	7.2 (183)	17.0 (432)	7.0 (178)	15.6 (396)

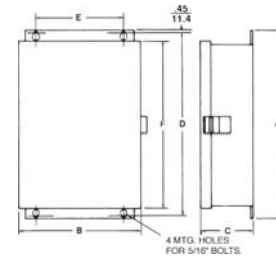

Enclosed Noncombination Starters, NEMA Type 1

Enclosed Noncombination Starters, NEMA Type 12/3R

Product Number	Dimension A	Dimension B	Dimension C	Dimension D	Dimension E	Dimension F
QS2BNA	18.0 (458)	11.0 (279)	7.2 (183)	17.0 (432)	7.0 (178)	15.6 (396)
QS2DNA	18.0 (458)	11.0 (279)	7.2 (183)	17.0 (432)	7.0 (178)	15.6 (396)
QS2FNA	18.0 (458)	11.0 (279)	7.2 (183)	17.0 (432)	7.0 (178)	15.6 (396)
QS2GNA	18.0 (458)	11.0 (279)	7.2 (183)	17.0 (432)	7.0 (178)	15.6 (396)
QS2HNA	25.5 (648)	11.5 (292)	8.8 (224)	24.0 (610)	8.0 (203)	24 (610)
QS2INA	25.5 (648)	11.5 (292)	8.8 (224)	24.0 (610)	8.0 (203)	24 (610)

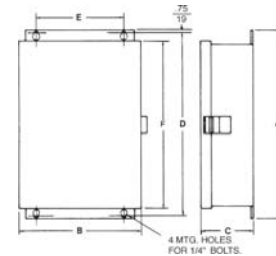

Enclosed Noncombination Starters, NEMA Type 12/3R

Enclosed Combination Starters, NEMA Types 1 and 12/3R

	Dimension A	Dimension B	Dimension C	Dimension D	Dimension E	Dimension F
All	26.3 (668)	11.0 (279)	7.2 (183)	25.5 (648)	7.0 (178)	24.0 (610)

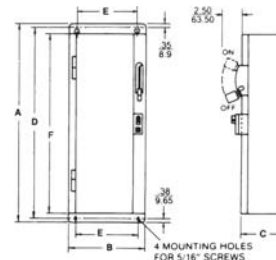

Enclosed Combination Starters, NEMA Types 1 and 12/3R

Reduced Voltage Starters

Solid State

ASTAT®-IBP Plus

Description

The ASTAT®-IBP Plus is a solid state reduced voltage starter with integral bypass. The ASTAT®-IBP Plus consists of an electronic control module, a power base consisting of six SCRs in back-to-back parallel pairs for optimum performance, and a fully rated bypass contactor.

The ASTAT®-IBP Plus advanced control technology individually fires each phase in a specially selected sequence to offer reliable performance for the smooth acceleration of all types of loads, reducing shock to mechanical components, thereby extending component and motor life. When the motor ramps up to full speed, the digital electronic control energizes a contactor placed in parallel with the SCRs. When the contactor closes, the SCRs are bypassed and the electronic circuit stops firing the SCRs. This method results in an improved thermal design that eliminates the need for heat sinks and cooling fans.

The ASTAT®-IBP Plus bypass contactor is fully rated and can start a motor in backup mode in case of a failure in the electronics or SCRs. In addition, the ASTAT®-IBP Plus rated from 200-600 VAC and allows for 115% continuous current-carrying capability, matching the characteristics of a 1.15 service factor motor.

The ASTAT®-IBP Plus includes many new advanced features that are standard to enhance performance and allow greater application flexibility. This simplifies the ordering process and results in lower inventories for distributors and OEM's.

Application

ASTAT®-IBP Plus solid state reduced voltage starters are used to reduce or eliminate mechanical shock and stress on mechanical components, such as V-belts, gear boxes, chain drives, couplings, transmissions, and shafts. ASTAT®-IBP Plus reduced voltage starters are used to:

- Reduce brownout conditions and may limit demand charges,
- Control processes,
- Smoothly accelerate and decelerate loads, and
- Restrict process surges.

Typical applications include compressors, pumps, belted equipment, centrifuges, conveyors, cranes, crushers, winches, fans and blowers, extruders, flywheels, hoists, laundry extractors, mixers, packaging equipment, machine tools, shears, saws, spinning frames, textile machinery, winders, and wire-drawing machines.

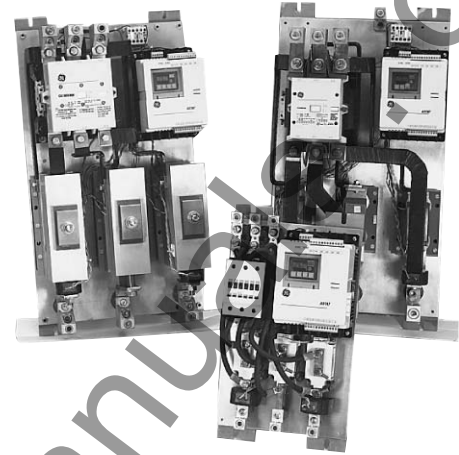

ASTAT®-IBP Plus Solid State Reduced Voltage

Features

- Adjustable starting current limit and starting torque
- Soft start
- Soft stop
- Pump control setting for acceleration and deceleration
- Monitoring:
 - Motor Current
 - Line Voltage
 - KW
 - Power Factor
 - Elapsed Time
- 2 Programmable Inputs
- 2 Programmable Outputs
- Electronic Overload Protection: Class 10, 20 or 30 overload selection
- Fault Diagnostics
- Error Tracing
- Kick Start setting
- Integral Snubbers and MOVs
- RS232 Communications

Standards

- UL listed to UL508 and cUL listed
- UL file number E100757



Reduced Voltage Starters Solid State

Section 2

ASTAT®-IBP Plus

350 Hp Max. @ 600V
Three-Phase
50/60 Hz

Standard Features

Digital Technology

Provides precise phase control of the back-to-back SCRs over each half-cycle. The ASTAT®-IBP Plus design allows initial motor torque to be adjusted from 10%-90% at normal starting torque.

Digital Control Panel

Displays setup and operating parameters with an alphanumeric display. Provides accurate setting of parameters with visible indication of starter status, motor current, line voltage, kW, power factor, elapsed time and error codes.

Soft Starting

The most frequent application for the ASTAT®-IBP Plus starter. It provides a linear increase in voltage at the motor terminals, eliminates starting shock to the load, and reduces stress on mechanical components, such as gears and belt drives. A special pump control setting is available as a standard feature to reduce pressure surges in pump systems during starting thereby limiting stress on pipe systems and valves.

Three-Segment Ramp

The Three-Segment Ramp consists of:

1. The initial voltage ramp, which lasts for five cycles, brings the motor voltage from 0 to the preset initial pedestal voltage (10%-90%).
2. The acceleration ramp, which increases the motor voltage from the preselected initial voltage to 100% voltage over the selected acceleration time period.
3. The fast ramp, which brings the motor voltage to 100% if the motor reaches full speed before the end of the acceleration ramp.

Electronic Overload Relay

Overload relay has selectable trip class for Class 10, 20 or 30 applications. Starting characteristics and Hp selection tables are rated as Standard Duty (300% current for 30 seconds—IEC 10/NEMA 20) or Heavy Duty (450% current for 30 sec—IEC 20/NEMA 30). Provides accurate, repeatable, reliable protection for both the motor and the ASTAT®.

Kick Start

Initially boosts start loads with a high breakaway torque (belted conveyors, extruders, mixers). This feature may be engaged (95% voltage for a period of 1-999 ms) or it may be disengaged for applications not requiring a kick start.

Current Limit

The motor starting current may be limited with an adjustable current range from 100-450% of the frame rating.

Soft Stopping

Allows a motor-driven load to be brought to rest over an adjustable time period independently of the acceleration ramp. A deceleration cycle, exclusively designed for pump control, may be programmed to limit water hammer, surges, and sudden valve closure.

Motor Thermistor Protection Limit

Used with motors protected by a PTC thermistor. Trips within 200 ms when the resistance is higher than 2800-3200 ohms. Resets when the resistance falls below 1000 ohms.

Snubbers

An RC network connected in parallel with an SCR to protect against commutation spikes.

MOVs

Metal oxide varistors protect electronic components against external voltage spikes.

Error Traceability

Displays the last four error codes on the alphanumeric display. Provides feedback for corrective action.

Phase-Loss Protection

The ASTAT®-IBP Plus will not operate if a phase loss is detected before starting or while soft starting or stopping the motor.

Fully Rated Contactor

The ASTAT®-IBP Plus is supplied with a fully rated bypass contactor across the entire product line. In case of failure of the electronics or the SCRs, the bypass contactor can start and run the motor in backup mode.

Reduced Heat Generation

The SCRs are used only during starting and stopping of the motor. After the motor ramps up, the bypass contactor is engaged, allowing the ASTAT®-IBP Plus to run cool, thus eliminating the need for ventilation, large heat sinks, and fans, which are required for conventional solid state reduced voltage starters.

Dual Ramp

A secondary ramp may be programmed for ramp up, ramp down including a different initial torque parameter and will be enabled as an alternate ramp when the "A" parameter is "ON" or enabled through one of the two programmable inputs.

Service Factor

Motor Service Factor may be adjusted from 1.0 to 1.3 to meet the application need of most motors.

Overvoltage/Undervoltage Protection

Adjustable parameters allow overvoltage conditions to be detected from 0-30% above nominal voltage set during the initiation. Undervoltage may be detected from 0-50% under the nominal voltage. Trip time may be set from 0-99 seconds after the condition is detected. If conditions return to normal the trip time is reset. L1 voltage is monitored to provide this protection.

Reduced Voltage Starters Solid State

ASTAT®-IBP Plus

350 Hp Max. @ 600V

Three-Phase

50/60 Hz

Standard Features (continued)

Overcurrent/Undercurrent Protection

Adjustable parameters allow overcurrent conditions to be detected from 0-50% above nominal current set during the initiation. Undercurrent may be detected from 0-99% of the nominal current. Trip time may be set from 0-99 seconds after the condition is detected. If conditions return to normal the trip time is reset. This feature is not functional in bypass applications.

Metering Functions

Phase A may be monitored for Voltage, Current, Power Factor plus motor kilowatts are calculated from the information obtained from phase A and B. Accuracy is $\pm 3\%$ if the unit is calibrated during initialization.

Elapsed Time Monitor

An elapsed time monitor function is also provided as standard which displays run time in hours x 1000 and is read on the LED Display.

Programmable Inputs

Two inputs may be programmed for one or more of the following functions: Soft Stop, Pump Control, Kick Start, Local/Remote Control, Tach feedback ramp and Dual (second) Ramp. Functions may be programmed to be OFF, ON or assigned to 1 of the 2 programmable inputs and activated with a dry contact closure between terminals 57-3 or 57-4.

Programmable Outputs

Two programmable output relays (1r) and (3r) may be assigned to the following functions: End of Ramp, Fault, Run, or to detect Undervoltage, Overvoltage, Undercurrent or Overcurrent limits set for those parameters as a pre alarm to shutdown. Note: Relay (2r) has been factory assigned to End of Ramp for Bypass function.

Local Communications

The ASTAT®-IBP Plus is capable of RS232C ASCII communication with the software package provided. This serial communication is suitable for on site setup of soft starters with a PC at the local sight. Communication distance is generally limited to 3 meters. An optional cable is available with RS232 connector on one end and identified ASTAT® terminal connections on the other. Please order product number QCX000170.

Remote Communication

Modbus® RTU¹—This single ended protocol may be used up to distances of 10 meters. For distances greater than 10 meters it is recommended that a RS232 to RS485 converter be used. The recommended converter is GE product number RS485RS232120. This converter requires a separate 120 Volt power supply. Up to 247 addressable ASTAT® stations may be connected to this network.

DeviceNet™²— A gateway module is available QCPDNTUS, which includes a 1-meter cable to connect the module to the ASTAT®. The module is DIN rail mount, compact in size and may be easily added to new or existing enclosures with ASTAT® Plus soft starters. The module incorporates a Brad Harrison®³ micro connector for connection to the DeviceNet™ network. This gateway supports the COS (Change Of State), Polling and Explicit Messaging connections. All ASTAT® parameters and settings may be viewed/changed using the DeviceNet module and the appropriate connection. Up to 63 ASTAT® addresses, each requiring a module may be integrated into the network.

Thermal Overload Memory

The overload relay retains a memory of overload conditions to closely profile the motor winding thermal condition to insure adequate protection under repetitive overload conditions. The memory is maintained as long as control power remains applied to the soft starter.

SCR Overtemperature Protection

All units are fitted with thermostats to protect against overheating.

Frequency Error Detection

Electronic frequency sensing does not allow the starter to begin load ramp-up if frequency is less than 45 Hz or greater than 65 Hz, providing protection to the motor and starter if the frequency is excessively out of tolerance.

Long Start-Time Protection

If the current limit is set too low and/or the starting time is longer than 60 seconds, it is assumed that motor heating could be excessive. The ASTAT®-IBP Plus starter provides long start-time protection and disconnects the load under these conditions.

¹Modbus® is a registered trademark of AEG Schneider Automation INC.

²DeviceNet™ is a trademark of Open DeviceNet Vendor Association (ODVA).

³Brad Harrison® is a registered trademark of Woodhead Industries, Inc.



Reduced Voltage Starters

Solid State

QI3

ASTAT®-IBP Plus

Open

Three-Phase Standard-Duty Ratings

Frame Rating Amps	Max. Starting Current for 30 sec., A	Max. Nominal Current for 30 sec.	Starter Size	Motor Horsepower @ 200V	Motor Horsepower @ 230V	Motor Horsepower @ 460V	Motor Horsepower @ 575V	KW 1.0 S.F. 380V/415V	Product Number	List Price GO-10A5	Weight (lbs.)
55	165	300%	K	15	20	40	50	30	QI3KDP ¹	\$2093.00	15
68	204	300%	L	20	25	50	60	37	QI3LDP	\$2475.00	15
80	240	300%	Y	25	25	60	75	37	QI3YDP	\$3070.00	15
105	315	300%	M	30	30	75	75	55	QI3MDP	\$3319.00	22
130	390	300%	Z	40	50	100	125	63	QI3ZDP	\$4052.00	28
156	468	300%	N	50	60	125	150	75	QI3NDP	\$4331.00	28
192	576	300%	P	60	75	150	200	90	QI3PDP ²	\$5697.00	65
248	744	300%	Q	75	100	200	250	110	QI3QDP	\$6240.00	65
302	906	300%	R	100	100	250	300	160	QI3RDP	\$7625.00	65
361	1083	300%	S	125	150	300	350	200	QI3SDP	\$8450.00	130

Overload relay parameter of "0" is set to 0 N2.

Three-Phase Heavy-Duty Ratings

Frame Rating Amps	Max. Starting Current for 30 sec., A	Max. Nominal Current for 30 sec.	Starter Size	Motor Horsepower @ 200V	Motor Horsepower @ 230V	Motor Horsepower @ 460V	Motor Horsepower @ 575V	KW 1.0 S.F. 380V/415V	Product Number	List Price GO-10A5	Weight (lbs.)
55	248	450%	K	15	20	40	50	30	QI3KDP ¹	\$2093.00	15
105	473	450%	M	30	30	75	75	50	QI3MDP	\$3319.00	22
130	585	450%	Z	40	50	100	125	63	QI3ZDP	\$4052.00	28
156	702	450%	N	50	60	125	150	75	QI3NDP	\$4331.00	28
192	864	450%	P	60	75	150	200	90	QI3PDP ²	\$5697.00	65
361	1116	450%	S	75	100	200	250	165	QI3SDP	\$8450.00	130

Overload relay parameter of "0" is set to 0 N3.

¹The heavy-duty ratings of starter sizes L and Y are identical to those of size K.

²The heavy-duty ratings of starter sizes Q and R are identical to those of size P.

NOTE: All open units are wired for separate customer-supplied and fused control power rated va @ 120 VAC.

Number of Starts Per Hour

The number of starts per hour for the ASTAT®-IBP Plus varies by size, maximum current setting, and ramp-up time. The following table is provided to help select the appropriate unit for the intended application.

Starter Size	Starting Current		Number of Starts per Hour			
	% of Frame Rating	Current, A	Times			
			30	20	10	5
K	300%	165	6	15	30	30
	450%	246	1	8	20	30
L	300%	204	1	6	20	30
	450%	306	—	—	8	12
Y	300%	240	1	8	20	30
	450%	360	—	—	—	—
M	300%	315	6	12	28	30
	450%	473	2	8	15	30
Z	300%	390	4	10	20	30
	450%	585	1	6	10	30
N	300%	468	2	8	15	30
	450%	702	—	4	10	20
P	300%	576	6	14	30	30
	450%	864	2	4	10	20
Q	300%	744	4	9	24	30
	450%	1116	—	—	6	12
R	300%	906	2	4	10	25
	450%	1359	—	—	—	6
S	300%	1083	1	0	8	12
	300%	1116 ³	1	3	8	12

³ Maximum heavy-duty rating.

Accessories Cover Kit

Accessory cover used on open IBP starters to cover internal wire connections and to provide a more finished appearance.

For Use With	Outline Number	Product Number	List Price GO-10A5
QI3KDP, LDP, YDP, MDP	55-216620	QI3XX001	\$60.00
QI3ZDP, NDP	55-216620	QI3XX002	\$70.00
QI3PDP, QDP, RDP	55-216620	QI3XX003	\$80.00
QI3SDP	55-216620	QI3XX004	\$100.00

PC Connector Kit

Connects ASTAT®-IBP Plus to PC for set-up. Kit consists of a 1.5m long cable with RS-232 connector on one end and identified wire leads for connection to ASTAT®-IBP Plus on the other end.

Product Number	List Price GO-10A5
QCX000170	\$20.00

Communications Module

Description	Product Number	List Price GO-10A5
DeviceNet Module	QCPDNTUS	\$950.00

Reduced Voltage Starters

Solid State

CR374, CR375

ASTAT®-IBP Plus

Enclosed

1 Enclosure Form

Transfer the product number digit corresponding to the enclosure form to box 1 of the "product number" line.

Product No. Digit	Enclosure Form
4	Noncombination
5	Combination

2 Starter Size and Enclosure Type

Select the starter size from the Size Selection tables, then find the desired enclosure type in the table below. Transfer the three product number digits to box 2 in the "product number" line and the price to box 2 in the "price" line.

All units are supplied with box lugs for line and load connections and terminal strips for external starting, where applicable.

Standard-Duty Ratings—300% current for 30 seconds maximum

Current Rating Amps (AC-3) ³	Starter Size	Motor Horsepower			
		200 V	230 V	460 V	575 V
55	K	15	20	40	50
68	L	20	25	50	60
80	Y	25	25	60	75
105	M	30	30	75	75
130	Z	40	50	100	125
156	N	50	60	125	150
192	P	60	75	150	200
248	Q	75	75	200	250
312	R	100	100	250	300
361	S	125	150	300	350

Heavy-Duty Ratings—450% current for 30 seconds maximum

Starter Size	Motor Horsepower			
	200 V	230 V	460 V	575 V
K ¹	15	20	40	50
M	30	30	75	75
Z	40	50	100	125
N	50	60	125	150
P ²	60	75	150	200
S	75	75	200	250

¹The heavy-duty ratings of starter sizes L and Y are identical to those of size K.

²The heavy-duty ratings of starter sizes Q and R are identical to those of size P.

³High inertia loads should not exceed .95 X frame Amps.

Starter Size	Noncombination Forms				Combination Forms ⁴			
	Product No. Digits, Type 1 Enclosure	List Price Adder, GO-10A6	Product No. Digits, Type 12/3R Enclosure	List Price Adder, GO-10A6	Product No. Digits, Type 1 Enclosure	List Price Adder, GO-10A6	Product No. Digits, Type 12/3R Enclosure	List Price Adder, GO-10A6
K	KD1	\$2669.00	KD2	\$2698.00	KD1	\$2817.00	KD2	\$2907.00
L	LD1	\$3549.00	LD2	\$3710.00	LD1	\$3809.00	LD2	\$3950.00
Y	YD1	\$4144.00	YD2	\$4305.00	YD1	\$4654.00	YD2	\$4875.00
M	MD1	\$4392.00	MD2	\$4553.00	MD1	\$4754.00	MD2	\$4950.00
Z	ZD1	\$5125.00	ZD2	\$5286.00	ZD1	\$5825.00	ZD2	\$6091.00
N	ND1	\$5731.00	ND2	\$5899.00	ND1	\$6821.00	ND2	\$6921.00
P	PD1	\$7097.00	PD2	\$7265.00	PD1	\$8187.00	PD2	\$8550.00
Q	QD1	\$7640.00	QD2	\$7920.00	QD1	\$9256.00	QD2	\$9415.00
R	RD1	\$9025.00	RD2	\$9585.00	RD1	\$10296.00	RD2	\$11518.00
S	SD1	\$9850.00	SD2	\$10550.00	SD1	\$11064.00	SD2	\$12750.00

⁴Combination forms have a fused disconnect or a circuit breaker in form CR375.

Reduced Voltage Starters Solid State

CR374, CR375

ASTAT®-IBP Plus

Enclosed

3 Select Line Voltage and Rectifier Fuses

Select the line voltage and, if desired, rectifier fuses by frame size. Transfer the product number digit to box 3 in the "product number" line and the price to box 3 in the "price" line.

Rectifier Fuses	Frame Size	Product No. Digit by Line Volts			List Price Adder, GO-10A6	Product No. Digit	List Price Adder, GO-10A6
		200/208 V	230 V	460 V			
No	All	2	3	4	—	5	—
Standard-Duty	K	6	7	8	\$320.00	9	\$420.00
	L, Y, M	6	7	8	\$475.00	9	\$580.00
	Z, N, P, Q	6	7	8	\$625.00	9	\$735.00
	R, S	6	7	8	\$1260.00	9	\$1375.00
Heavy-Duty	K	A	B	C	\$320.00	D	\$420.00
	L, Y, M	A	B	C	\$475.00	D	\$580.00
	Z, N, P, Q	A	B	C	\$625.00	D	\$735.00
	R, S	A	B	C	\$1260.00	D	\$1375.00

These fuses remain in the circuit and protect the system even in bypass mode.

4 Select Control Circuit Options

Select control circuit options by frame size. Transfer the product number digit to box 4 in the "product number" line and the price to box 4 in the "price" line.

Starter Size	Product No. Digit	Control Circuit	List Price Adder, GO-10A6
All except R, S	1	120 separate control/with CCF	—
	2	CPT standard capacity with 2 primary and 1 secondary fuse	\$160.00
	3	CPT 100 VA extra capacity with 2 primary and 1 secondary fuse	\$225.00
R, S	1	120 separate control/with CCF	—
	2	CPT standard capacity with 2 primary and 1 secondary fuse	\$225.00
	3	CPT 100 VA extra capacity with 2 primary and 1 secondary fuse	\$295.00

5 Select Contactor Options

An isolation contactor disconnects line power from the ASTAT®-IBP Plus.

Select the contactor options. Transfer the product number digit to box 5 in the "product number" line and the price to box 5 in the "price" line.

Product No. Digits	Contactor	List Price Adder, GO-10A6									
		K	L	Y	M	Z	N	P	Q	R	S
AA	Bypass Only	—	—	—	—	—	—	—	—	—	—
BA	Bypass & Isolation	\$275.00	\$325.00	\$385.00	\$416.00	\$695.00	\$738.00	\$950.00	\$1283.00	\$2363.00	\$3241.00



Publications and Reference: See Section 17 for a complete list of additional product-related publications

Reduced Voltage Starters

Solid State

CR374, CR375

ASTAT®-IBP Plus

Enclosed

6 Select Fused Disconnect or Circuit Breaker Options

Select the fused disconnect or circuit breaker (for form CR375 enclosures). Transfer the product number digit to box 6 in the "product number" line and the price to box 6 in the "price" line.

Product No. Digit	Starter Size	CR375 Fused Disconnect	List Price Adder, GO-10A6	Starter Size	CR375 Circuit Breaker	List Price Adder, GO-10A6
A	Any	Unfused	\$800.00	—	N/A	—
D	K-M, Y	100 A max.	\$1000.00	—	N/A	—
E	M-N, Z	200 A max.	\$1200.00	—	N/A	—
F	M-R, Z	400 A max.	\$1400.00	—	N/A	—
G	R-S	600 A max.	\$1750.00	K-M, Y	100 A	\$950.00
H	—	N/A	—	M-N, Z	150 A	\$1150.00
J	—	N/A	—	N-Q, Z	225 A	\$1200.00
K	—	N/A	—	Q-S	400 A	\$1600.00
L	—	N/A	—	R-S	600 A	\$1900.00

Fuse holders are for class J fuses. Customer to supply fuses.

7 Select Pilot Device Options

Select pilot device options. Transfer the product number digit to box 7 in the "product number" line and the price to box 7 in the "price" line.

Product No. Digit	START/STOP Push Button	H-O-A Selector Switch	Red Light	Green Light	List Price Adder, GO-10A6
A		None			—
B	•				\$130.00
C		•			\$115.00
D			RUN		\$85.00
E				RUN	\$85.00
F			RUN	OFF	\$170.00
G	•		RUN		\$215.00
H	•			RUN	\$215.00
J		•	RUN		\$200.00
K		•		RUN	\$200.00
L	•		RUN	OFF	\$300.00
M		•	RUN	OFF	\$285.00
N	START only	•			\$180.00
R	START only	•	RUN		\$265.00
S	START only	•		OFF	\$265.00
T	START only	•	RUN	OFF	\$350.00
U	•	•			\$245.00
V	•	•	RUN		\$330.00
X	•	•		OFF	\$330.00
Z	•	•	RUN	OFF	\$415.00

8 Select Auxiliary Contacts and Relays

Select auxiliary contacts and relays. These contacts are in addition to the one each standard normally open and normally closed contacts on the interposing relay. Transfer the product number digit to box 8 in the "product number" line and the price to box 8 in the "price" line.

Product No. Digit	Extra Relays	3 NO & 1 NC	2 NO & 2 NC	1 NO & 3 NC	List Price Adder, GO-10A6
0		None			—
1	1	•			\$62.00
2	1		•		\$62.00
3	1			•	\$62.00
5	2	•			\$120.00
6	2		•		\$120.00
7	2			•	\$120.00

Auxiliary relay coils are wired in parallel with the control relay and are picked up when the ASTAT®-IBP Plus is activated.

9 Select Meter Options

Select meter options, then transfer the product number digit to box 9 in the "product number" line and the price to box 9 in the "price" line.

Product No. Digit	1-Phase ¹ Ammeter	1-Phase ¹ Voltmeter	3-Phase Ammeter	3-Phase Voltmeter	Elapsed ¹ Time Meter	List Price Adder, GO-10A6
A			None			—
B	•					\$750.00
C		•				\$750.00
D			•			\$960.00
E				•		\$960.00
F					•	\$275.00
G	•	•				\$1500.00
H	•			•		\$1710.00
J	•				•	\$1025.00
K		•	•			\$1710.00
L		•			•	\$1025.00
M			•	•		\$1920.00
N			•		•	\$1235.00
P				•	•	\$1235.00
R	•	•			•	\$1775.00
S	•			•	•	\$1985.00
T		•	•		•	\$1775.00
W			•	•	•	\$2195.00

¹ Single phase ammeter, voltmeter and elapsed time meter function is included as a digital readout on the ASTAT display. For separate analog meter(s) select catalog number digit shown in table 9.

Reduced Voltage Starters Solid State

Q13

ASTAT®-IBP Plus

Technical Specifications

I/O Terminal Board Specifications

Power I/O Terminals

Terminal	Function	Description
1L1, 3L2, 5L3	Mains Input	3ph input voltage
2T1, 4T2, 6T3	Motor Output	Output terminals to 3ph AC motor
TBA1, TBA2	Input Control Voltage	110/120V AC, +10%, -15%

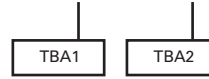

Digital Inputs

Terminal	Function	Description
57	Common for digital input	This is a common terminal for the digital input terminals specified below.
1	Run	Run order. Command signal may be provided by one NO dry momentary contact to terminals 1 and 57. Stop order. Command signal may be provided by one NC dry momentary contact to terminals 2 and 57. Note: Run/Stop permanent command is allowed linking 1-57 and using one dry NO contact to 2-57 terminals.
2	Stop	
3	Programmable input I3	These two inputs are programmable. Can be assigned to the following internal functions <div style="display: flex; justify-content: space-around;"> <div style="text-align: center;"> soft stop pump control kick start </div> <div style="text-align: center;"> linear ramp dual ramp selection local/remote control </div> </div> Command signal should be provided by one NC dry contact to terminals 57-3 or terminals 57-4. By switching this contact ON/OFF it is possible to enable or disable the assigned function.
4	Programmable input I4	

Digital Outputs

Terminal	Function	Description
11, 12, 14	Programmable relay 1r	11-12 = N.C., 11-14 = N.O. dry contacts. This relay can be assigned to several internal output functions. As default assigned to function RUN.
23, 24	Fixed relay 2r	23-24 = N.O. dry contact. This relay is assigned to function EOR for bypass contactor control.
33, 34	Programmable relay 3r	33-34 = N.O. dry contact. This relay can be assigned to several internal output functions.
Common for all relay output contacts		Maximum usage voltage: 380VAC (B300-UL) Thermal Current: 8A AC-15 use: 220V/3A, 380V/1A DC-15 use: 30V max/3.5A

Analog I/O

Terminal	Function	Description
8	Analog input common (-)	This is a common terminal for the analog input terminal number 7, and analog output terminal number 9. 0.5V analog input for speed feedback. It should be provided by a DC tachogenerator coupled to the motor. This speed feedback signal is required when the "linear ramp" function is used.
7	TG feedback input (+)	
9	Current Output (+)	0.10V DC analog output for current measurement purpose (1 x I = 2V DC output) Load impedance 10KΩ or higher

Motor Thermistor Terminals

Terminal	Function	Description
5, 6	Motor thermistor input	This input allows a motor thermistor with a response value from 2.8 to 3.2KΩ, and a reset value from 0.75 to 1KΩ to control motor temperature. When the motor thermistor is not used, a link must be used in terminals 5-6.

Communications

Terminal	Function	Description
SG, TD, RD	Gr, Tx, Rx data	RS232C, 3 wires, half duplex. Maximum cable length 3 meters (10 feet) Asynchronous data transmission, 9600 Bauds, 1 bit start, 8 bits data, 2 bits stop, no parity



Publications and Reference: See Section 17 for a complete list of additional product-related publications

Reduced Voltage Starters Solid State QC2

ASTAT®-IBP Plus Technical Specifications

General Specifications

Volts Rating	3ph AC Systems - Up to 600V for QI3xDP ASTAT®-IBP Plus series
Frequency	50/60 - Hz - Control range of 45-65 Hz

Control Specifications

Control System	Digital system with microcontroller Starting ramp with progressive increase in voltage and current limitation
Initial Voltage (Pedestal)	% - 30-95 Un
Initial (Starting) Torque	% - 10-90 Mdirect start
Kick Start	% - 95 Un (90% Mdirect start), adjustable 0 to 999 ms
Motor Unit Ratio	0.4 to 1.2
Current Limit	Adjustable from 1 to 4.5 (I _r /I _n) Max. 4.5 I _n
Acceleration Ramp Time	s - 1-45 (standard or linear ramp up)
Bypass	Direct control of a bypass contactor
Brake Time by Ramp	1 to 60 (1 to 60 in secondary ramp) adjustable independently of starting ramp time (types: standard, pump control or linear ramp down)
Monitoring	Motor current, line voltage (monitors L1), power, power factor and elapsed time

Running

External Control	Start-Stop
Acceleration Phase	Adjustable time
Stop Phase	Power cut-off/Ramp/Pump control

Inputs/Outputs

Inputs	4 digital optocoupled. Two fixed (Start, Stop), and 2 programmable (I3, I4) 1 Analog 0-5VDC for Tachogenerator input feedback
Outputs	2 programmable relays (1r, 3r); 1 fixed relay (2r) 1 Analog 0-10VDC output for current metering

ASTAT®-IBP Losses

Frame	Control Circuit (watts)	Power Circuit (watts)	Bypass Contactor Inrush (va)	Bypass Contactor Holding (va)
K	15	189	191	17
L	15	210	191	17
Y	15	250	191	17
M	15	277	191	17
Z	15	342	350	20
N	15	524	350	20
P	15	750	425	20
Q	15	900	425	20
R	15	1350	425	20
S	15	1800	750	25

Bypass contactor used on all forms

Protections

Current Limit	Adjustable from 1 to 4.5 (I _r /I _n) Max. 4.5 I _n
Overload	IEC class 10 and 20; NEMA class 10, 20 and 30 all selectable
Cool-down Time after Overload Trip	See Restart Times
Loss on Input Phase	s - Trip at 3
Thyristor Short Circuit	ms - Trip at 200
Heatsink Overheating	ms - Trip at 200
Motor Thermistor	ms - Trip at 200 if thermistor impedance > response value
Loss on Output Phase	s - Trip at 3
Stalled Rotor	ms - Trip at 200
Supply Frequency Error	Hz - If f < 45 or f > 65, will not start
Overcurrent	100 to 150% I _n ; trip time adjustable from 0 to 99 sec.
Undercurrent	0 to 99% I _n ; trip time adjustable from 0 to 99 sec.
Overvoltage ¹	100 to 130% Un; trip time adjustable from 0 to 99 sec. (L1 voltage is monitored to provide this protection.)
Undervoltage ¹	0 to 50% Un; trip time adjustable from 0 to 99 sec. (L1 voltage is monitored to provide this protection.)
Error (CPU)	ms - 60
Memory	4 former errors
Long Start Time	s - 2 x ta (ta = acceleration ramp time)

¹L1 voltage is monitored to provide this protection.

Environmental Conditions

Operation Temperature	0°C - 0 to +55 (derate output current by 1.5% 0°C above 40°C)
Relative Humidity	% - 95% without condensation
Maximum Altitude	m - 3000 (derate output current by 1%/100m above 1000m)
Mounting Position	Vertical
Protection Degree	IP00, UL Open

Standards

cUL, UL	UL, cUL conforming to UL508, UL File E 153901 (open), 100757 (enclosed)
Conducted & radiated emissions	Conforming IEC 947-4-2, Class A
Electrostatic discharges	Conforming to IEC 1000-4-2, level 3
Radioelectric interference	Conforming to IEC 1000-4-6, level 3 and to IEC 1000-4-3, level 3
Immunity to fast transients	Conforming to IEC 1000-4-4, level 3
Immunity to Surge Voltage	Conforming to IEC 1000-4-5, level 3

Reduced Voltage Starters Solid State

Q13

ASTAT®-IBP Plus
Technical Specifications

www.geelectrical.com

IEC Class 10

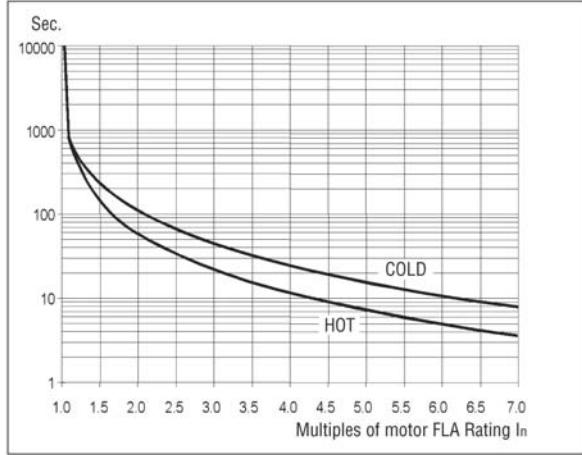

IEC Class 20

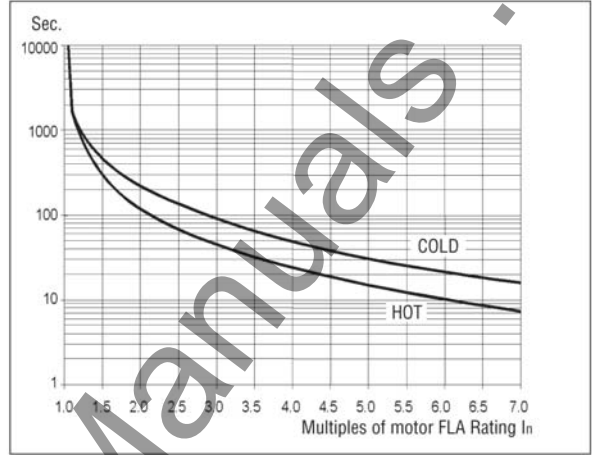

NEMA 10

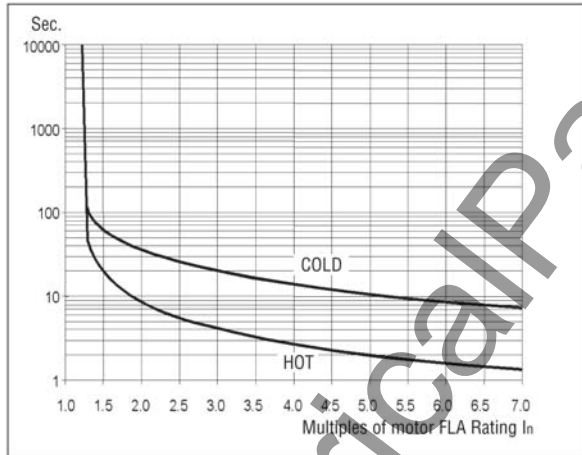

NEMA 20

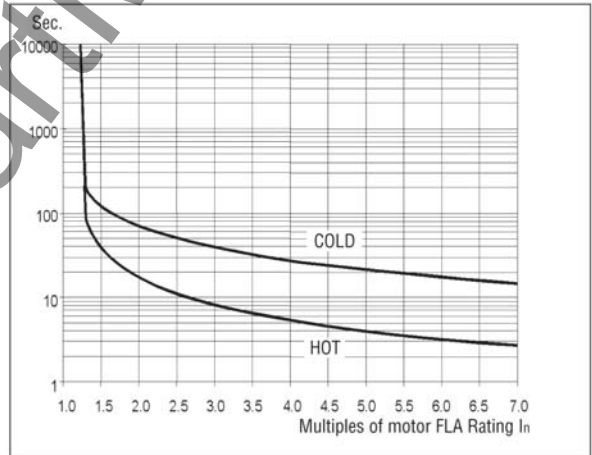

NEMA 30

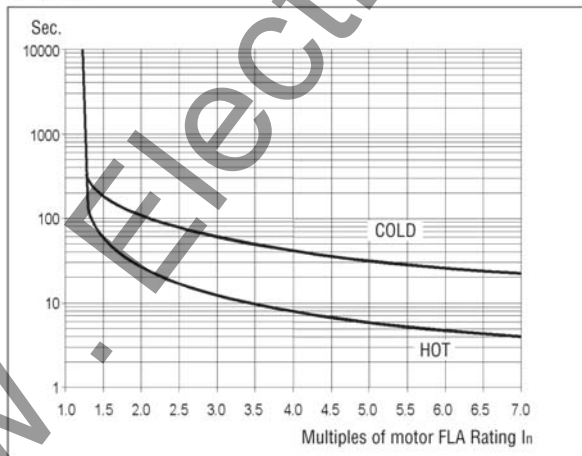

Thermal memory:

If the control voltage is not removed, the unit has a cool down characteristic. The time for cool down is 300 sec. after the overload trip.

If the control voltage is removed after tripping, you must wait at least 5 minutes before the unit can be restarted. See Section 4-10 for restart limitations.

Note: The ASTAT®-IBP Plus allows the user to select motor protection according to IEC Class 10, 20 and NEMA 10, 20, or 30, selectable by "0"-overload- parameter.

ASTAT®-IBP Plus Thermal Characteristics



Publications and Reference: See Section 17 for a complete list of additional product-related publications

Reduced Voltage Starters Solid State

QI3 ASTAT®-IBP Plus Technical Specifications

Branch Circuit Guide for Starter Specifications

ASTAT®-IBP Plus starters are suitable for use on a circuit capable of delivering not more than¹ rms symmetrical amperes, for² volts maximum, when used with³ for short-circuit protection. (Replace the circled numbers with the appropriate values from the following tables for branch-circuit protection with a circuit breaker, Class J fuses, or semiconductor fuses.⁴)

Note that when ASTAT®-IBP Plus reduced voltage starters are used in conjunction with semiconductor fuses, Type 2 coordination to IEC 947-4 is attained. These fuses are recommended for best overall short-circuit protection. The semiconductor fuses specified in the table below may provide branch-circuit protection. Refer to applicable local electrical codes.

Branch-Circuit Protection for CR375 Series with a Circuit Breaker³

Frame Size	Max. Circuit Breaker Size	Max. Short Circuit Current ¹	
		208/240/480 V ²	600 V ²
K	100 A	25 kA	10 kA
L	100 A	25 kA	10 kA
Y	100 A	25 kA	10 kA
M	150 A	25 kA ⁵	10 kA
Z	150 A	25 kA ⁵	10 kA
N	225 A	25 kA ⁵	10 kA
P	225 A	25 kA ⁵	10 kA
Q	400 A	25 kA ⁵	10 kA
R	600 A	25 kA ⁵	18 kA
S	600 A	25 kA ⁵	18 kA

Branch-Circuit Protection with Class J Fuses³

Frame Size	Max. Class J Fuse Size	Max. Short Circuit Current ¹	
		208/240/480/600 V ²	
K	100 A	100 kA	
L	100 A	100 kA	
Y	100 A	100 kA	
M	400 A	100 kA	
Z	400 A	100 kA	
N	400 A	100 kA	
P	400 A	100 kA	
Q	400 A	100 kA	
R	600 A	100 kA	
S	600 A	100 kA	

Branch-Circuit Protection with Semiconductor Fuses³

Frame Size	Gould-Shawmut Semiconductor Fuses							Max. Short-Circuit Current ¹
	at 208/240/480 V ²			at 208/240/480/600 V ²				
	Standard-Duty	Heavy-Duty	Fuse Type	Standard-Duty	Heavy-Duty	Fuse Type		
K	125 A	175 A	A50QS	125 A	150 A	A70QS	100 kA	
L	150 A	—	A50QS	150 A	—	170QS	100 kA	
Y	175 A	—	A50QS	175 A	—	A70QS	100 kA	
M	225 A	350 A	A50QS	225 A	250 A	A70QS	100 kA	
Z	300 A	400 A	A50QS	300 A	400 A	A70QS	100 kA	
N	350 A	450 A	A50QS	350 A	450 A	A70QS	100 kA	
P	400 A	600 A	A50QS	400 A	450 A	A70QS	100 kA	
Q	500 A	—	A50QS	500 A	—	A70QS	100 kA	
R	600 A	—	A50QS	600 A	—	A70QS	100 kA	
S	700 A	1000 A	A50QS	700 A	800 A	A70QS	100 kA	

⁴Semiconductor fuses may be added to combination or noncombination forms.

⁵Open starters of size M, Z, N, P, Q, R, and S have a branch circuit rating of 65 kA when used with circuit breakers that are rated for 65 kA or higher branch circuit protection.

Open Unit Installation

Open units are designed to use 5/16" bolts for attachment to mounting surfaces.

Use minimum of 75°C copper wire only for connections to ASTAT®-IBP Plus terminals. The minimum wire size must conform to the 75°C table according to applicable electrical codes. Tighten connections to the torque values given in the table.

Product Number	Wire Range	Torque in./lb.
QI3K, QI3L, QI3Y, QI3M, QI3Z, QI3N	#14-#2 AWG	125
QI3P, QI3Q	#6 AWG-350 kcmil	275
QI3R, QI3S	#2 AWG-2x250 kcmil (or 1x600 kcmil)	550

Reduced Voltage Starters Solid State

Q13

ASTAT®-IBP Plus

Open

Outlines and Dimensions in. (For Estimating Only)

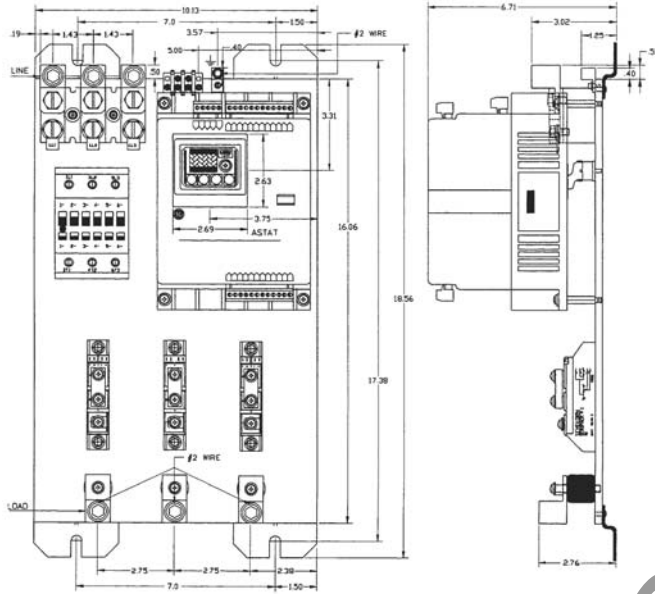

Frame Sizes K, L, and Y Dimensions

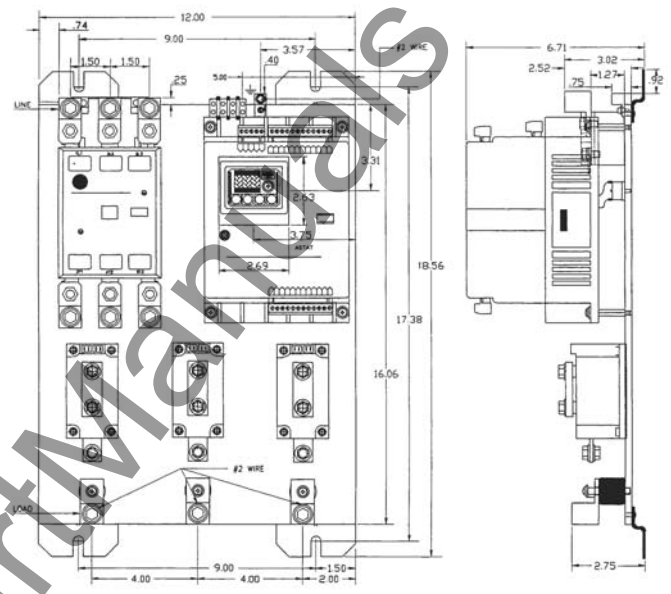

Frame Sizes Z and N Dimensions

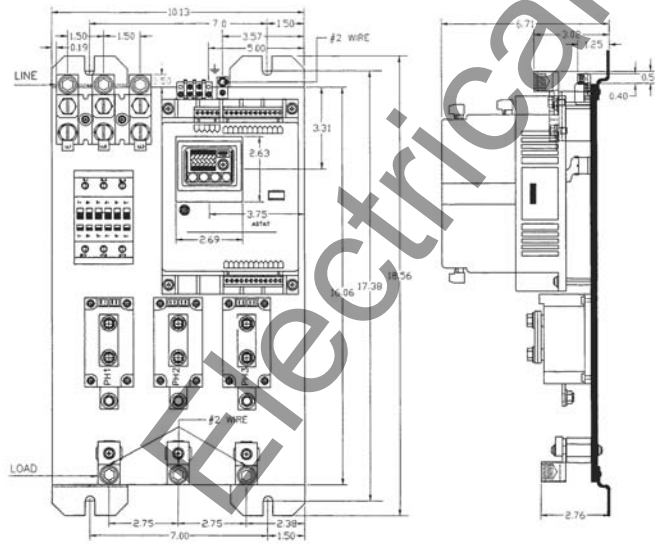

Frame Size M Dimensions

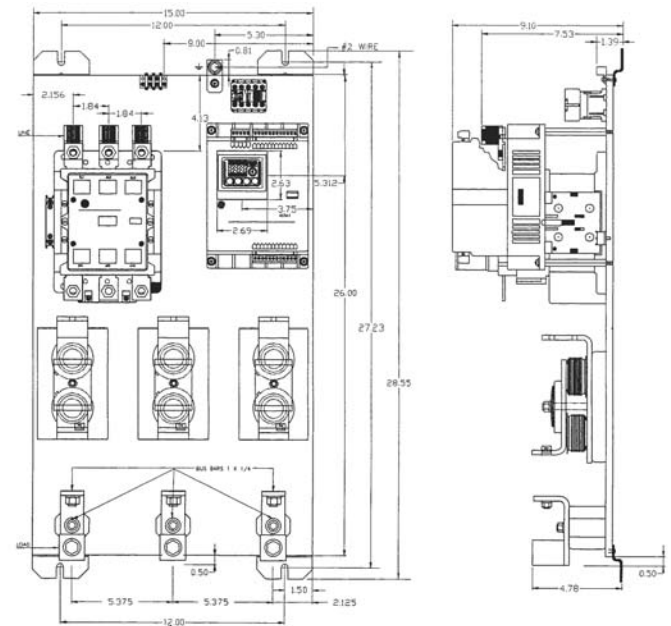

Frame Sizes P, Q and R Dimensions



Publications and Reference: See Section 17 for a complete list of additional product-related publications

Reduced Voltage Starters Solid State

Section 2

Q13

ASTAT®-IBP Plus

Open

Outlines and Dimensions in. (For Estimating Only)

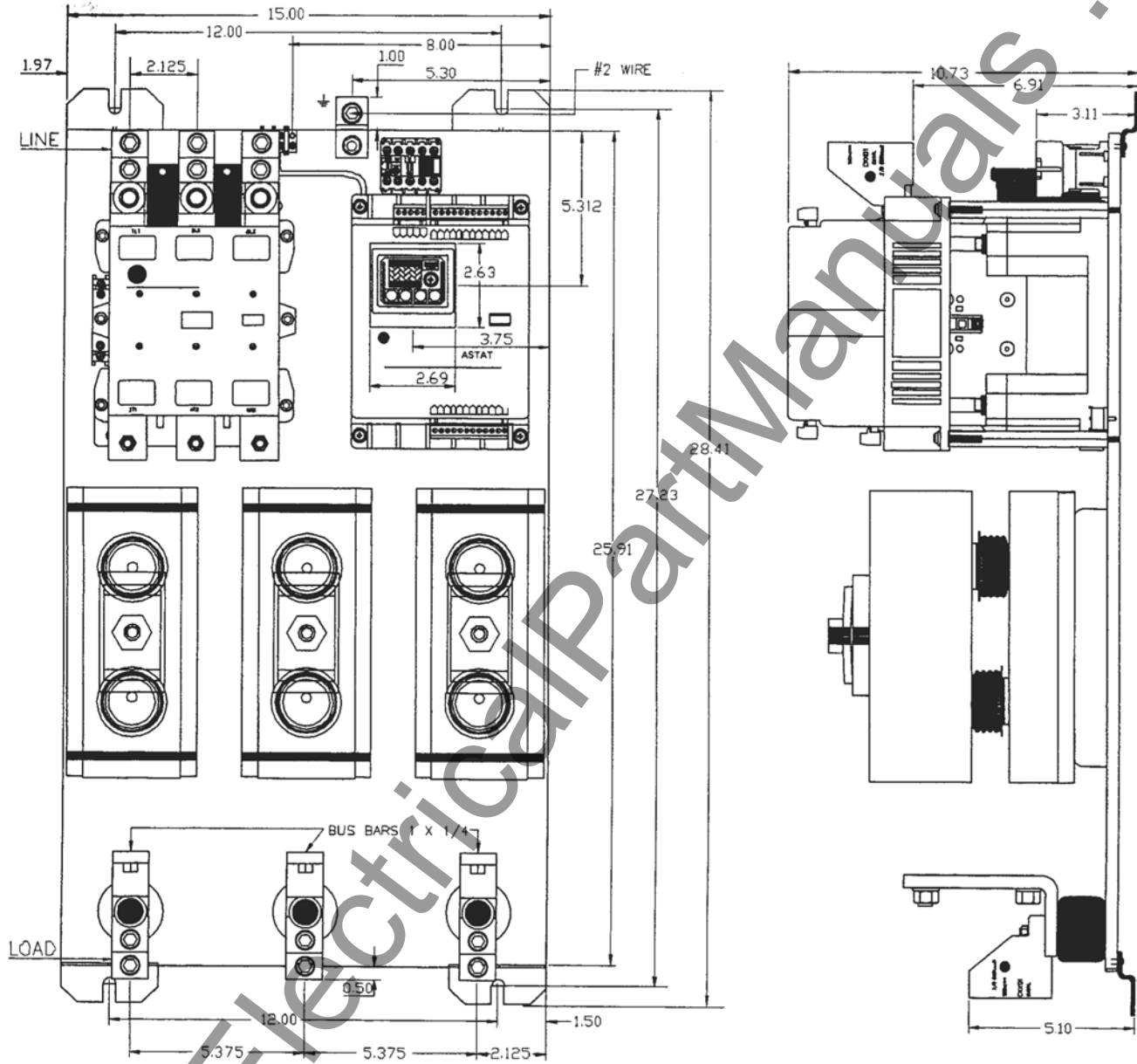

Frame Size S Dimensions

Reduced Voltage Starters Solid State

CR374, CR375

ASTAT®-IBP

Enclosed

Outlines, Dimensions and Weights (For Estimating Only)

Enclosed Noncombination Starters—Inches (mm)

- A1 = Box height (excluding flanges)
- A2 = Overall height (including flanges)
- B = Width
- C = Depth
- D = Box height between centers of mounting holes
- E = Edge of flange to center of end mounting hole
- F = Distance between outer mounting holes
- G = Distance between end and center mounting holes

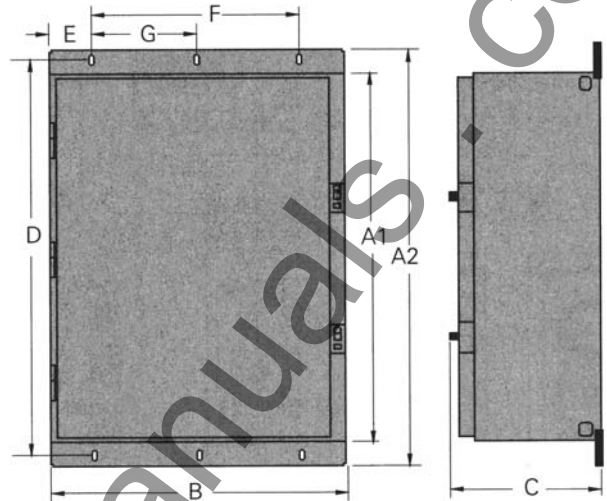

CR374 Series Type 1

Frame Size	A1	A2	B	C	D	E	F	G	Approx. Weight		
									lb.	kg	
K, L, Y	45.9 (1166)	49.7 (1262)	18.8 (478)	9.4 (239)	48 (121)	1.5 (3.8)	15.8 (40)	—	—	56	25
M	45.9 (1166)	49.7 (1262)	18.8 (478)	9.4 (239)	48 (121)	1.5 (3.8)	15.8 (40)	—	—	65	29
Z										72	33
N										72	33
P ¹ , Q ¹	51.7 (1323)	55.5 (1410)	21.9 (556)	12.8 (325)	53.6 (136)	1.5 (3.8)	18.1 (46)	—	—	166	70
P, Q	71.2 (1809)	75.7 (1923)	35.9 (912)	13.0 (330)	73.4 (187)	1.5 (3.8)	31.9 (81)	16.0 (41)	—	176	80
R ¹ S ²	51.7 (1323)	55.5 (1410)	21.9 (556)	12.8 (325)	53.6 (136)	1.5 (3.8)	18.1 (46)	—	—	166	70
R S	71.2 (1809)	75.7 (1923)	35.9 (912)	13.0 (330)	73.4 (187)	1.5 (3.8)	31.9 (81)	16.0 (41)	—	176	80
										254	115

¹ Unit without isolation and without current metering.

² Unit without isolation, without current metering, and without SCR fuses.

CR374 Series Type 3R/12

Frame Size	A1	A2	B	C	D	E	F	G	Approx. Weight		
									lb.	kg	
K, L, Y	46.2 (1173)	49.7 (1262)	18.8 (478)	9.4 (239)	47.8 (121)	1.5 (3.8)	15.8 (40)	—	—	56	25
M	46.2 (1173)	49.7 (1262)	18.8 (478)	9.4 (239)	47.8 (121)	1.5 (3.8)	15.8 (40)	—	—	65	29
Z										72	33
N										72	33
P ¹ , Q ¹	52.1 (1313)	55.5 (1410)	21.9 (556)	12.8 (325)	53.6 (136)	1.5 (3.8)	18.1 (46)	—	—	166	70
P, Q	72.0 (1829)	75.7 (1923)	35.9 (912)	13.0 (330)	73.4 (187)	1.5 (3.8)	31.9 (81)	16.0 (41)	—	176	80
R ¹ S ²	52.1 (1313)	55.5 (1410)	21.9 (556)	12.8 (325)	53.6 (136)	1.5 (3.8)	18.1 (46)	—	—	166	70
R S	72.0 (1829)	75.7 (1923)	35.9 (912)	13.0 (330)	73.4 (187)	1.5 (3.8)	31.9 (81)	16.0 (41)	—	176	80
										254	115

¹ Unit without isolation and without current metering.

² Unit without isolation, without current metering, and without SCR fuses.



Publications and Reference: See Section 17 for a complete list of additional product-related publications

Reduced Voltage Starters

Solid State

CR374, CR375

ASTAT®-IBP

Enclosed

Outlines, Dimensions and Weights (For Estimating Only)

Section 2

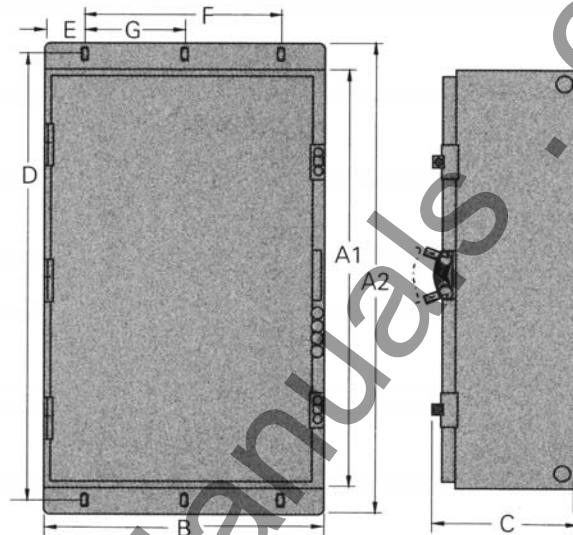

Enclosed Combination Starters—Inches (mm)

- A1 = Box height (excluding flanges)
- A2 = Overall height (including flanges)
- B = Width
- C = Depth
- D = Box height between centers of mounting holes
- E = Edge of flange to center of end mounting hole
- F = Distance between outer mounting holes
- G = Distance between end and center mounting holes

CR375 Series Type 1

Frame Size	A1	A2	B	C	D	E	F	G	Approx. Weight	
									lb.	kg
K ¹ , L ¹ , V ¹	54.3 (1379)	58.3 (1481)	18.0 (457)	8.5 (216)	57.0 (1448)	1.5 (38)	15.0 (381)	— —	75	34
K, L, Y	45.9 (1166)	49.7 (1262)	28.1 (714)	9.4 (239)	44.4 (1128)	1.5 (38)	25.1 (638)	— —	80	36
M ¹ , Z ¹ , N ¹	54.3 (1379)	58.3 (1481)	18.0 (457)	8.5 (216)	57.0 (1448)	1.5 (38)	15.0 (381)	— —	85	39
M Z N	45.9 (1166)	49.7 (1262)	28.1 (714)	9.4 (239)	44.4 (1128)	1.5 (38)	25.1 (638)	— —	88 96 96	40 43 43
P ¹ , Q ¹	76.5 (1943)	80.5 (2045)	19.0 (483)	8.5 (216)	78.7 (1999)	1.5 (38)	16.0 (406)	— —	210	95
P, Q	71.2 (1809)	75.7 (1923)	35.9 (912)	13.0 (330)	73.4 (1864)	1.5 (38)	33.1 (841)	16.6 (402)	256	116
R ¹ , S ¹	76.5 (1943)	80.5 (2045)	19.0 (483)	8.5 (216)	78.7 (1999)	1.5 (38)	16.0 (406)	— —	310	141
R S	71.2 (1809)	75.7 (1923)	35.9 (912)	13.0 (330)	73.4 (1864)	1.5 (38)	33.1 (841)	16.6 (402)	256 334	116 152

¹ Units without SCR fuses, isolation contactor, and current metering.

CR375 Series Type 3R/12

Frame Size	A1	A2	B	C	D	E	F	G	Approx. Weight	
									lb.	kg
K ¹ , L ¹ , V ¹	54.3 (1379)	58.3 (1481)	18.0 (457)	8.5 (216)	57.0 (1448)	1.5 (38)	15.0 (381)	— —	75	34
K, L, Y	46.2 (1173)	49.7 (1262)	28.1 (714)	9.4 (239)	44.4 (1128)	1.5 (38)	25.1 (638)	— —	80	36
M ¹ , Z ¹ , N ¹	54.3 (1379)	58.3 (1481)	18.0 (457)	8.5 (216)	57.0 (1448)	1.5 (38)	15.0 (381)	— —	85	39
M Z N	46.2 (1173)	49.7 (1262)	28.1 (714)	9.4 (239)	44.4 (1128)	1.5 (38)	25.1 (638)	— —	88 96 96	40 43 43
P ¹ , Q ¹	76.5 (1943)	80.5 (2045)	19.0 (483)	8.5 (216)	78.7 (1999)	1.5 (38)	16.0 (406)	— —	210	95
P, Q	72.0 (1829)	75.7 (1923)	35.9 (912)	13.0 (330)	73.4 (1864)	1.5 (38)	33.1 (841)	16.6 (402)	256	116
R ¹ , S ¹	76.5 (1943)	80.5 (2045)	19.0 (483)	8.5 (216)	78.7 (1999)	1.5 (38)	16.0 (406)	— —	310	141
R S	72.0 (1829)	75.7 (1923)	35.9 (912)	13.0 (330)	73.4 (1864)	1.5 (38)	33.1 (841)	16.6 (402)	256 334	116 152

¹ Units without SCR fuses, isolation contactor, and current metering.

Reduced Voltage Starters Solid State

ASTAT®-CD Plus

700 Horsepower Max. @ 500V
Three-Phase
50/60Hz

Description

GE's new ASTAT®-CD Plus solid state reduced voltage starter (soft starter) features microprocessor control digital technology. The control board uses surface mounted devices for higher reliability and more optimum design. Set-up and adjustment is performed through a four-button keypad with parameters and feedback provided through the four-character LED display. The design includes optoelectrically-isolated inputs and various levels of protection in their circuits to immunize the equipment against external disturbances and their effects.

The ASTAT®-CD Plus starters advanced control technology individually fires each phase in a selected sequence to offer reliable performance and smooth acceleration for a variety of loads reducing mechanical shock to the motor driven system resulting in extended component and motor life.

Each starter consists of an electronic control module and a power base consisting of six SCR's arranged in back-to-back parallel pairs for optimum performance.

The ASTAT®-CD Plus starter offers many traditional features such as motor overload protection, energy saving mode, adjustable voltage ramp, adjustable starting current limit, kick start, soft stop, loss of load and loss of phase protection. These plus many **NEW standard** features such as pump starting control mode, jog (slow speed) mode, reverse jog, dual ramp and dc braking mode coupled with voltage, current, kW, power factor and elapsed time monitoring make the ASTAT®-CD Plus the choice for most applications. In addition the ASTAT®-CD Plus offers as **standard** two programmable inputs, three programmable output relays and is RS232C and DeviceNet communications capable for maximum configuration flexibility. Protection is also high on the list of ASTAT®-CD Plus **standard** features and includes thermal memory, overvoltage, undervoltage, overcurrent, undercurrent, frequency error, long start and long slow speed time. Error feedback is provided through the LED display, which reports on the last four errors with 21 different error messages. ASTAT®-CD Plus designed to do more...providing a solution to customer motor load starting problems.

Application

ASTAT®-CD Plus solid state reduced voltage starters are used to reduce or eliminate mechanical shock and stress on mechanical components such as V-belts, gear boxes, chain drives, couplings, transmissions and shafts. ASTAT®-CD Plus reduced voltage starters are used to reduce brownout conditions and may limit demand charges. ASTAT®-CD Plus solid state reduced voltage starters are used to control processes, to smoothly accelerate and decelerate loads, to position and move loads and restrict process surges.

Typical applications include: compressors, pumps, belted equipment, centrifuges, conveyors, cranes, crushers, winches, fans/blowers, extruders, flywheels, hoists, laundry extractors, mixers, packaging equipment, machine tools, shears, saws, spinning frames, textile machinery, winders and wire drawing machines.



ASTAT®-CD Plus Solid State Reduced Voltage

Standard Features

Digital Technology

Provides precise phase control of the back to back SCRs over each 1/2 cycle. The ASTAT®-CD Plus design allows initial motor torque to be adjusted from 10%-90% of normal starting torque.

Digital Control Panel

Displays setup and operating parameters with alphanumeric display. Provides accurate setting of parameters with visible indication of starter status, motor current, line voltage, kW, power factor, elapsed time and error codes.

Soft Starting

Soft starting is the most frequent application for the ASTAT®-CD Plus starter. It provides a linear increase in voltage at the motor terminals, eliminates starting shock to the load and reduces stress on mechanical components, such as gears, belt drives, piping and valves. A pump control setting is available as a standard feature to reduce pressure surges in pump systems during starting thereby limiting stress on pipe systems and valves.

Three-Segment Ramp

The Three-Segment Ramp consists of:

1. The initial voltage ramp, which lasts for five cycles, brings the motor voltage from 0 to the preset initial pedestal voltage (10%-90%).
2. The acceleration ramp, which increases the motor voltage from the preselected initial voltage to 100% voltage over the selected acceleration time period.
3. The fast ramp, which brings the motor voltage to 100% if the motor reaches full speed before the end of the acceleration ramp.

Electronic Overload Relay

Overload relay has selectable trip class for Class 10, 20 or 30 applications. Starting characteristics and hp selection tables are rated as Standard Duty (300% current for 30 seconds— IEC 10/NEMA 20) or Heavy Duty (450% current for 30 sec— IEC 20/NEMA 30). Provides accurate, repeatable, reliable protection for both the motor and the ASTAT®.

Kick Start

Used to initially boost start loads with a high breakaway torque (belted conveyors, extruders, mixers). Feature may be engaged (95% voltage for a time period 1–999ms) or feature may be disengaged for applications not requiring kick start.



Publications and Reference: See Section 17 for a complete list of additional product-related publications

Reduced Voltage Starters Solid State

ASTAT®-CD Plus

700 Horsepower Max. @ 500V
Three-Phase
50/60Hz

Section 2

Standard Features (continued)

Current Limit

The motor starting current may be limited with adjustable current range from 100-450% of frame rating. This feature is used to reduce starting current to limit brownout/low voltage conditions during motor starting.

Soft Stopping

Allows motor driven load to be brought to rest over an adjustable time period independently of the acceleration ramp. A deceleration cycle exclusively designed for pump control may be programmed to limit water hammer, surges and sudden valve closure.

Energy Saving Mode

Reduces motor voltage under no load or low load conditions thereby reducing reactive power required by the motor. Motor voltage is automatically increased as the load is increased. Feature may be disengaged when desired.

DC Braking

Braking current is adjustable over a range from 0-250% of the motor nameplate full-load current for a predetermined time 0-99 seconds. Feature may be engaged when desired. Requires external contactor.

Loss of Load Detection

Prevents motor burnout for application in which driven load is also cooling motor (for example a submersible pump motor). Time delay is 10 seconds after load loss.

Motor Thermistor Protection Input

Used with motors protected with PTC thermistor. Trips within 200ms when resistance is higher than 2800-3200 ohms. Resets when resistance falls below 1000 ohms.

Stalled Rotor Protection

Power is removed from motor when stalled condition exceeds 200ms. Provides motor protection and process feedback.

Snubbers

RC network connected in parallel with SCR to protect against commutation spikes.

Retry

The retry function allows up to four attempts to restart the motor after a fault, allows user to set time between retries from 1-99 seconds.

Dual Ramp

A secondary ramp may be programmed for ramp up, ramp down plus the initial torque parameter which will be enabled as an alternate ramp when the "A" parameter is "ON" or enabled through one of the two programmable inputs.

Service Factor

Motor Service Factor may be adjusted from 1.0 to 1.3 to meet the application need of most motors.



ASTAT®-CD Plus

Overvoltage/Undervoltage Protection

Adjustable parameters allow overvoltage conditions to be detected from 0-30% above nominal voltage set during the initialization. Undervoltage may be detected from 0-50% under the nominal voltage. Trip time may be set from 0-99 seconds after the condition is detected. If conditions return to normal the trip time is reset. L1 voltage is monitored to provide this protection.

Overcurrent/Undercurrent Protection

Adjustable parameters allow overcurrent conditions to be detected from 0-50% above nominal current set during the initialization. Undercurrent may be detected from 0-99% of the nominal current. Trip time may be set from 0-99 seconds after the condition is detected. If conditions return to normal the trip time is reset. This feature is not functional in bypass applications.

Monitoring Functions

Phase A may be monitored for Voltage, Current, Power Factor plus motor kilowatts calculated from the information obtained from phase A. Accuracy is $\pm 3\%$ if unit is calibrated during initialization. An elapsed time monitor function is also provided which displays run time in hours x 1000.

Programmable Inputs

Two inputs may be programmed for one or more of the following functions: Soft Stop, Pump Control, Kick Start, Energy Saver, Bypass Function, DC Brake, Slow Speed Control (7% or 14%), Reverse Slow Speed (20%), Local or Remote Control, Tach feedback ramp and Dual (second) Ramp. Functions may be programmed to be OFF, ON or assigned to 1 of the 2 programmable inputs and activated with a dry contact closure.

Programmable Outputs

Three programmable output relays may be assigned to the following functions: End of Ramp, DC Brake (contactor control), Fault, Run, Jog or to detect Undervoltage, Overvoltage, Undercurrent or Overcurrent limits set for those parameters as a pre alarm to shutdown. Relay (2r) will automatically be assigned to End of Ramp when Bypass function "z" is on. Relay (3r) will be automatically assigned to DC Brake control when DC Brake function B is on.

Reduced Voltage Starters Solid State

ASTAT®-CD Plus

700 Horsepower Max. @ 500V
Three-Phase
50/60Hz

Standard Features (continued)

Slow Speed (Jog)/Reverse Slow Speed

Allows user to engage 7 or 14% speed to align or position loads. Reverse jog (20% speed) may be used to loosen jam in mechanical load. Current is limited to the nominal current setting programmed from the keypad or function may be engaged from programmable input I3 or I4.

Tachometer Feedback

Provides linear speed ramp independent of load torque. Speed feedback is provided by a user supplied tachometer attached to the driven shaft. May be used for both the acceleration and deceleration ramp. A voltage transducer is required to match tachometer voltage to the required input voltage range (0-5VDC) programmed from the keypad or function may be engaged from programmable input I3 or I4.

Analog Output

0-10 Volt DC output for current measurement purpose. When the ASTAT® is at rated Amps, the output equals 2V DC.

Communications

The ASTAT®-CD Plus is supplied with communications capability to a computer via ASCII protocol. Through serial communications, this feature may be programmed to "ON" or be enabled through an assignment to one of the two programmable inputs.

MOVs

Metal oxide varistors to protect electronic components against external voltage spikes.

Error Traceability

Displays last 4 error codes on alphanumeric display. Provides feedback for corrective action.

Phase Loss Protection

Removes power from motor terminals in 3 seconds upon detection of phase loss. Provides additional protection against motor burnout.

Thermal Overload Memory

Overload relay retains memory of overload conditions to closely profile motor winding thermal condition to insure adequate protection under repetitive overload conditions. Memory is maintained as long as the control power remains applied to the soft starter.

SCR Over Temperature Protection

Heat sinks on sizes J-X are fitted with thermostats to protect SCR against fan failure.

Frequency Error Detection

Electronic frequency sensing will not allow starter to begin load ramp-up if frequency is < 45 Hz or > 65 Hz, providing protection to the motor and starter should frequency be excessively out of tolerance.



ASTAT®-CD Plus Size Q Starter

Long Start Time Protection

If current limit is set too low and/or starting time is longer than two times the preselected acceleration ramp time (240 sec max.), it is assumed that the motor heating could be excessive. The ASTAT®-CD Plus starter provides long start time protection and disconnects the load under these conditions.

Local Communications

The ASTAT®-CD Plus is capable of RS232C ASCII communication with the software package provided. This serial communication is suitable for on site setup of soft starters with a PC at the local sight. Communication distance is generally limited to 3 meters. An optional cable is available with RS232 connector on one end and identified ASTAT® terminal connections on the other. Please order product number QCX000170.

Remote Communication

Modbus® RTU—This single ended protocol may be used up to distances of 10 meters. For distances greater the 10 meters it is recommended that a RS232 to RS485 converter be used. The recommended converter is GE product number RS485RS232120. This converter requires a separate 120 Volt power supply. Up to 247 addressable ASTAT® stations may be connected to this network.

DeviceNet™—A gateway module is available QCPDNTUS, which includes a 1-meter cable to connect the module to the ASTAT®. The module is DIN rail mount, compact in size and may be easily added to new or existing enclosures with ASTAT®Plus soft starters. The module incorporates a Brad Harrison® micro connector for connection to the DeviceNet™ network. This gateway supports the COS (Change Of State), Polling and Explicit Messaging connections. All ASTAT® parameters and settings may be viewed/changed using the DeviceNet module and the appropriate connection. Up to 63 ASTAT® addresses, each requiring a module may be integrated into the network.



Publications and Reference: See Section 17 for a complete list of additional product-related publications

Reduced Voltage Starters Solid State

Section 2

QC2 ASTAT®-CD Plus Open

ASTAT®-CD Plus solid state reduced voltage starters (also referred to as Soft Starters) provide smooth, stepless acceleration/deceleration of AC squirrel-cage induction motors from zero to full speed over an adjustable time period.

ASTAT®-CD Plus starters are supplied with 120/240 VAC (50/60 Hz) control power input. On starter sizes F-S, box lug terminals are supplied for line and load connections; on starter sizes T-V, order box lug terminal kits separately (see table below). Starters in sizes J and above are supplied with internal cooling fans.

Three-Phase

Current Rating Amps (AC-3) ¹	Standard-Duty, Heavy-Duty	Max. Nominal Current for 30 sec.	Motor Horsepower			KW 1.0 S.F. 380V/415V	Product Number	List Price G0-10A5	Approx. Weight lbs. (kg)
			@ 200V	@ 230V	@ 460V				
14	Standard-Duty	300%	3	3	7.5	7.5	QC2FDP	\$1350.00	9.48 (4.3)
	Heavy-Duty	450%	3	3	7.5	5.5			
17	Standard-Duty	300%	3	3	10	11	QC2GDP	\$1400.00	9.48 (4.3)
	Heavy-Duty	450%	3	3	10	7.5			
22	Standard-Duty	300%	5	7.5	15	13	QC2HDP	\$1450.00	9.48 (4.3)
	Heavy-Duty	450%	5	5	15	15			
34	Standard-Duty	300%	10	10	25	18.5	QC2IDP	\$1500.00	10.14 (4.6)
	Heavy-Duty	450%	7.5	7.5	20	15			
48	Standard-Duty	300%	15	15	30	25	QC2JDP	\$1630.00	27.56 (12.5)
	Heavy-Duty	450%	10	15	30	22			
63	Standard-Duty	300%	20	20	40	37	QC2KDP	\$1820.00	27.56 (12.5)
	Heavy-Duty	450%	15	20	40	30			
72	Standard-Duty	300%	20	25	50	45	QC2LDP	\$2200.00	37.48 (17)
	Heavy-Duty	450%	20	20	40	37			
105	Standard-Duty	300%	30	30	75	63	QC2MDP	\$2950.00	37.48 (17)
	Heavy-Duty	450%	30	30	60	55			
156	Standard-Duty	300%	50	60	125	90	QC2NDP	\$3850.00	99.20 (45)
	Heavy-Duty	450%	40	50	100	75			
240	Standard-Duty	300%	75	75	200	150	QC2QDP	\$5200.00	99.20 (45)
	Heavy-Duty	450%	60	75	150	110			
315	Standard-Duty	300%	100	125	250	200	QC2RDP	\$6100.00	121.25 (55)
	Heavy-Duty	450%	75	100	200	160			
370	Standard-Duty	300%	125	150	300	220	QC2SDP	\$6500.00	121.25 (55)
	Heavy-Duty	450%	100	125	250	200			
500	Standard-Duty	300%	150	200	400	300	QC2TDP	\$8350.00	176 (80)
	Heavy-Duty	450%	150	150	350	250			
630	Standard-Duty	300%	200	250	500	400	QC2UDP	\$10420.00	231 (105)
	Heavy-Duty	450%	200	200	400	315			
850	Standard-Duty	300%	300	350	700	560	QC2VDP ²	\$13650.00	265 (120)
	Heavy-Duty	450%	250	300	600	460			
1075	Standard-Duty	300%	400	500	1000	715	QC2XDP ³	\$18500.00	330 (150)
	Heavy-Duty	450%	350	400	800	600			

¹When operating motors at service factor loads, service factor amps must not exceed starter rating.

²Heavy-duty 800 amps max.

³Not UL listed. Available in open form only.

Terminal Lug Kits for Sizes T-V

Each terminal lug kit includes a set of 3 terminal lugs.
One kit each is required for line and load side connections.

Frame Size	Kit Product Number	List Price G0-10A5
T	CR370X1	\$270.00
U	CR370X2	\$270.00
V	CR370X3	\$360.00

PC Connector Kit

Connects ASTAT®-CD Plus to PC for set-up. Kit consists of a 1.5m long cable with RS-232 connector on one end and identified wire leads for connection to ASTAT®-CD Plus on the other end.

Product Number	List Price G0-10A5
QCX000170	\$20.00

Communications Module

Description	Product Number	List Price G0-10A5
DeviceNet Module	QCPDNTUS	\$950.00

Reduced Voltage Starters Solid State

CR370, CR371, CR373

ASTAT®-CD Plus

Enclosed

Noncombination

Section 2

Product Number Selection Instructions

1. Product numbers with # are incomplete. For starter sizes J and above in 12/3R enclosures, add one product number digit (in place of #) for overload relay current range for bypass contactor. Overload relay not included in pricing; add appropriate List Price Adder from Overload Relay Table (page 2-44).

Example:

To specify a non-combination starter used with a 460 V motor rated at 30 hp and a full load current of 40 amps in a Type 12 enclosure, select base product number CR370JD2412#.

Replace # with overload relay digit "E" from table, page 2-44. Complete product number is CR370JD2412E.

List Price \$2583.00

Overload Adder \$95.00

Total List Price, GO-10A6 \$2678.00

2. Product Notes

When operating motors at service factor loads, service factor amps must not exceed starter rating. Enclosed starters rated for 40°C ambient temperatures, derate rated controller current by 1.5%/°C above 40°C, up to a maximum of 50°C.

Enclosed Noncombination Starters (CR370)

List Price includes ASTAT®-CD Plus solid state reduced voltage starter in the enclosure selected. Starters for 200, 230, and 460 Volt motors are supplied with power supply configured for 115 V 60 Hz separate input, which includes control circuit fuses.

Interposing relay supplied with 1 extra normally open and 1 extra normally closed contact for optional user requirements. On starter sizes F-S, box lug terminal are supplied for line and load field power connections; on starter sizes T-V, order box lug terminals kits separately (see page 2-32).



Reduced Voltage Starters
Solid State
CR370
ASTAT®-CD Plus
 Enclosed
 Noncombination

www.gee.com

Three-Phase

Volts	Current Rating Amps (AC-3)	Standard-Duty Heavy Duty	Max. Nominal Current for 30 sec.	Motor Horsepower	NEMA Type 1				NEMA Type 12/3R			
					Product Number CR	List Price GO-10A6	Starter Size	Bypass Contactor	Product Number CR	List Price GO-10A6	Starter Size	Bypass Contactor
200V	14	Standard-Duty Heavy-Duty	300% 450%	3 3	370FD121	\$1955.00	F	—	370FD221	\$2040.00	F	No
200V	17	Standard-Duty Heavy-Duty	300% 450%	3 3	370GD121	\$2005.00	G	—	370GD221	\$2109.00	G	No
200V	22	Standard-Duty Heavy-Duty	300% 450%	5 5	370HD121	\$2055.00	H	—	370HD221	\$2159.00	H	No
200V	34	Standard-Duty Heavy-Duty	300% 450%	10 7.5	370ID121	\$2105.00	I	—	370ID2212#	\$2411.00	I	Yes
200V	34	Standard-Duty Heavy Duty	300% 400%	10 7.5	-	-	-	-	370ID221 ¹	\$2228.00	I	No
200V	48	Standard-Duty Heavy-Duty	300% 450%	15 10	370JD121	\$2350.00	J	—	370JD2212#	\$2583.00	J	Yes
200V	63	Standard-Duty Heavy-Duty	300% 450%	20 15	370KD121	\$2540.00	K	—	370KD2212#	\$2825.00	K	Yes
200V	72	Standard-Duty Heavy-Duty	300% 450%	20 20	370LD121	\$3330.00	L	—	370LD2212#	\$4143.00	L	Yes
200V	105	Standard-Duty Heavy-Duty	300% 450%	30 30	370MD121	\$4080.00	M	—	370MD2212#	\$5121.00	M	Yes
200V	156	Standard-Duty Heavy-Duty	300% 450%	50 40	370ND121	\$5250.00	N	—	370ND2212#	\$6418.00	N	Yes
200V	240	Standard-Duty Heavy-Duty	300% 450%	75 60	370QD121	\$6600.00	Q	—	370QD2212#	\$8413.00	Q	Yes
200V	315	Standard-Duty Heavy-Duty	300% 450%	100 75	370RD121	\$7500.00	R	—	370RD2212#	\$10393.00	R	Yes
200V	370	Standard-Duty Heavy-Duty	300% 450%	125 100	370SD121	\$7900.00	S	—	370SD2212#	\$11671.00	S	Yes
200V	500	Standard-Duty Heavy-Duty	300% 450%	150 150	370TD121	\$10200.00	T	—	370TD2212#	\$14705.00	T	Yes
200V	630	Standard-Duty Heavy-Duty	300% 450%	200 200	370UD121	\$13270.00	U	—	370UD2212#	\$19520.00	U	Yes
200V	850	Standard-Duty Heavy-Duty	300% 450%	300 250	370VD121 ²	\$16500.00	V	—	370VD2212# ²	\$2978.00	V	Yes
230V	14	Standard-Duty Heavy-Duty	300% 450%	3 3	370FD131	\$1955.00	F	—	370FD231	\$2040.00	F	No
230V	17	Standard-Duty Heavy-Duty	300% 450%	3 3	370GD131	\$2005.00	G	—	370GD231	\$2109.00	G	No
230V	22	Standard-Duty Heavy-Duty	300% 450%	7.5 5	370HD131	\$2055.00	H	—	370HD231	\$2159.00	H	No
230V	34	Standard-Duty Heavy-Duty	300% 450%	10 7.5	370ID131	\$2105.00	I	—	370ID231#	\$2411.00	I	Yes
230V	34	Standard-Duty Heavy Duty	300% 400%	10 7.5	-	-	-	-	370ID231 ¹	\$2228.00	I	No
230V	48	Standard-Duty Heavy-Duty	300% 450%	15 15	370JD131	\$2350.00	J	—	370JD2312#	\$2583.00	J	Yes
230V	63	Standard-Duty Heavy-Duty	300% 450%	20 20	370KD131	\$2540.00	K	—	370KD2312#	\$2825.00	K	Yes
230V	72	Standard-Duty Heavy-Duty	300% 450%	25 20	370LD131	\$3330.00	L	—	370LD2312#	\$4143.00	L	Yes
230V	105	Standard-Duty Heavy-Duty	300% 450%	30 30	370MD131	\$4080.00	M	—	370MD2312#	\$5121.00	M	Yes
230V	156	Standard-Duty Heavy-Duty	300% 450%	60 50	370ND131	\$5250.00	N	—	370ND2312#	\$6418.00	N	Yes
230V	240	Standard-Duty Heavy-Duty	300% 450%	75 75	370QD131	\$6600.00	Q	—	370QD2312#	\$8413.00	Q	Yes
230V	315	Standard-Duty Heavy-Duty	300% 450%	125 100	370RD131	\$7500.00	R	—	370RD2312#	\$10393.00	R	Yes
230V	370	Standard-Duty Heavy-Duty	300% 450%	150 125	370SD131	\$7900.00	S	—	370SD2312#	\$11671.00	S	Yes
230V	500	Standard-Duty Heavy-Duty	300% 450%	200 150	370TD131	\$10200.00	T	—	370TD2312#	\$14705.00	T	Yes
230V	630	Standard-Duty Heavy-Duty	300% 450%	250 200	370UD131	\$13270.00	U	—	370UD2312#	\$19520.00	U	Yes
230V	850	Standard-Duty Heavy-Duty	300% 450%	350 300	370VD131 ²	\$16500.00	V	—	370VD2312# ²	\$29728.00	V	Yes

¹27 amps max (SF 1.0).

²Heavy-duty 800 amps max.

Reduced Voltage Starters Solid State

CR370

ASTAT®-CD Plus

Enclosed

Noncombination

Three-Phase

Volts	Current Rating Amps (AC-3)	Standard-Duty Heavy-Duty	Max. Nominal Current for 30 sec.	Motor Horsepower	NEMA Type 1				NEMA Type 12/3R			
					Product Number CR	List Price GO-10A6	Starter Size	Bypass Contactor	Product Number CR	List Price GO-10A6	Starter Size	Bypass Contactor
460V	14	Standard-Duty Heavy-Duty	300% 450%	7.5 7.5	370FD141	\$1955.00	F	—	370FD241	\$2040.00	F	No
460V	17	Standard-Duty Heavy-Duty	300% 450%	10 10	370GD141	\$2005.00	G	—	370GD241	\$2109.00	G	No
460V	22	Standard-Duty Heavy-Duty	300% 450%	15 15	370HD141	\$2055.00	H	—	370HD241	\$2159.00	H	No
460V	34	Standard-Duty Heavy-Duty	300% 450%	25 20	370ID141	\$2105.00	I	—	370ID2412#	\$2411.00	I	Yes
460V	34	Standard-Duty Heavy-Duty	300% 400%	25 20	—	—	—	—	370ID241 ¹	\$2228.00	I	No
460V	48	Standard-Duty Heavy-Duty	300% 450%	30 30	370JD141	\$2350.00	J	—	370JD2412#	\$2583.00	J	Yes
460V	63	Standard-Duty Heavy-Duty	300% 450%	40 40	370KD141	\$2540.00	K	—	370KD2412#	\$2825.00	K	Yes
460V	72	Standard-Duty Heavy-Duty	300% 450%	50 40	370LD141	\$3330.00	L	—	370LD2412#	\$4143.00	L	Yes
460V	105	Standard-Duty Heavy-Duty	300% 450%	75 60	370MD141	\$4080.00	M	—	370MD2412#	\$5121.00	M	Yes
460V	156	Standard-Duty Heavy-Duty	300% 450%	125 100	370ND141	\$5250.00	N	—	370ND2412#	\$6418.00	N	Yes
460V	240	Standard-Duty Heavy-Duty	300% 450%	200 150	370QD141	\$6600.00	Q	—	370QD2412#	\$8413.00	Q	Yes
460V	315	Standard-Duty Heavy-Duty	300% 450%	250 200	370RD141	\$7500.00	R	—	370RD2412#	\$10393.00	R	Yes
460V	370	Standard-Duty Heavy-Duty	300% 450%	300 250	370SD141	\$7900.00	S	—	370SD2412#	\$11671.00	S	Yes
460V	500	Standard-Duty Heavy-Duty	300% 450%	400 350	370TD141	\$10200.00	T	—	370TD2412#	\$14705.00	T	Yes
460V	630	Standard-Duty Heavy-Duty	300% 450%	500 400	370UD141	\$13270.00	U	—	370UD2412#	\$19250.00	U	Yes
460V	850	Standard-Duty Heavy-Duty	300% 450%	700 600	370VD141 ²	\$16500.00	V	—	370VD2412# ²	\$29728.00	V	Yes

¹27 amps max (SF 1.0)

²Heavy-duty 800 amps max.



Publications and Reference: See Section 17 for a complete list of additional product-related publications

Reduced Voltage Starters

Section 2

Solid State

CR371

ASTAT®-CD Plus

Enclosed Combination
Fusible Disconnect Type

List Price includes ASTAT®-CD Plus solid state reduce voltage starter, in the enclosure selected, with a fusible disconnect switch operated by a side-mounted handle that indicates status as ON in the up position and OFF in the down position. The operating handle prevents entrance into the enclosure when the switch is in the ON position, unless the def eater mechanism is deliberately operated. The handle accepts up to 3 padlocks for securing the switch in the OFF position for maintenance shutdown. Provisions also are made for padlocking the handle in the ON position for continuous process applications requiring supervised shutdown. **Starters for 200, 230 and 460 volt motors are supplied with a control circuit transformer with 2 primary fuses and 1 secondary fuse.** Interposing relay supplied with 1 extra normally open and 1 extra normally closed contact for optional user requirements. On starter sizes F-S, box lug terminals are supplied for line and load field power connections; on starter sizes T-V, order box lug terminal kits separately (see page 2-32).

Product Number Selection Instructions

1. Product numbers with # are incomplete. For starter sizes J and above in 12/3R enclosures, add one product number digit (in place of #) for overload relay current range for bypass contactor. Overload relay not included in pricing; add appropriate List Price Adder from Overload Relay Table (page 2-44).

Example:

To specify a combination starter used with a 460 V motor rated at 30 hp and a full load current of 40 amps in a Type 12 enclosure, select base product number CR371JD242D2#.

Replace # with overload relay digit "E" from table, page 2-44. Complete product number is CR371JD242D2E.

List Price \$3698.00
Overload Adder \$95.00
Total List Price, GO-10A6 \$3793.00

2. Product Notes

When operating motors at service factor loads, service factor amps must not exceed starter rating. Enclosed starters rated for 40°C ambient temperatures, derate rated controller current by 1.5%/°C above 40°C, up to a maximum of 50°C.

Three-Phase

Volts	Current Rating Amps (AC-3)	Standard-Duty Heavy Duty	Max. Nominal Current for 30 sec.	Motor Horsepower	Class J Fuse Clip Size	NEMA Type 1				NEMA Type 12/3R			
						Product Number CR	List Price GO-10A6	Starter Size	Bypass Contactor	Product Number CR	List Price GO-10A6	Starter Size	Bypass Contactor
200V	14	Standard-Duty Heavy-Duty	300% 450%	3 3	30	371FD122B	\$2685.00	F	—	371FD222B	\$2919.00	F	No
200V	17	Standard-Duty Heavy-Duty	300% 450%	3 3	30	371GD122B	\$2735.00	G	—	371GD222B	\$2988.00	G	No
200V	22	Standard-Duty Heavy-Duty	300% 450%	5 5	60	371HD122C	\$2785.00	H	—	371HD222C	\$3038.00	H	No
200V	34	Standard-Duty Heavy-Duty	300% 450%	10 7.5	60	371ID122C	\$2862.00	I	—	371ID222C#	\$3317.00	I	Yes
200V	34	Standard-Duty Heavy Duty	300% 400%	10 7.5	60	—	—	—	—	371ID222C ¹	\$3134.00	I	No
200V	48	Standard-Duty Heavy-Duty	300% 450%	15 10	100	371JD122D	\$3440.00	J	—	371JD222D2#	\$3698.00	J	Yes
200V	63	Standard-Duty Heavy-Duty	300% 450%	20 15	100	371KD122D	\$3830.00	K	—	371KD222D2#	\$4140.00	K	Yes
200V	72	Standard-Duty Heavy-Duty	300% 450%	20 20	100	371LD122D	\$4681.00	L	—	371LD222D2#	\$5519.00	L	Yes
200V	105	Standard-Duty Heavy-Duty	300% 450%	30 30	200	371MD122E	\$5714.00	M	—	371MD222E2#	\$6900.00	M	Yes
200V	156	Standard-Duty Heavy-Duty	300% 450%	50 40	200	371ND122E	\$7179.00	N	—	371ND222E2#	\$8642.00	N	Yes
200V	156	Standard-Duty Heavy-Duty	300% 450%	50 40	400	371ND122F	\$7778.00	N	—	371ND222F2#	\$9241.00	N	Yes
200V	240	Standard-Duty Heavy-Duty	300% 450%	75 60	400	371QD122F	\$9328.00	Q	—	371QD222F2#	\$11336.00	Q	Yes
200V	315	Standard-Duty Heavy-Duty	300% 450%	100 75	600	371RD122G	\$10614.00	R	—	371RD222G2#	\$13902.00	R	Yes
200V	370	Standard-Duty Heavy-Duty	300% 450%	125 100	600	371SD122G	\$11014.00	S	—	371SD222G2#	\$15180.00	S	Yes

¹27 amps max (SF 1.0)

Reduced Voltage Starters Solid State CR371

ASTAT®-CD Plus
Enclosed Combination
Fusible Disconnect Type

Three-Phase

Volts	Current Rating Amps (AC-3)	Standard-Duty Heavy Duty	Max. Nominal Current for 30 sec.	Motor Horsepower	Class J Fuse Clip Size	NEMA Type 1				NEMA Type 12/3R			
						Product Number CR	List Price GO-10A6	Starter Size	Bypass Contactor	Product Number CR	List Price GO-10A6	Starter Size	Bypass Contactor
230V	14	Standard-Duty Heavy-Duty	300% 450%	3 3	30	371FD132B	\$2685.00	F	—	371FD232B	\$2919.00	F	No
230V	17	Standard-Duty Heavy-Duty	300% 450%	3 3	30	371GD132B	\$2735.00	G	—	371GD232B	\$2988.00	G	No
230V	22	Standard-Duty Heavy-Duty	300% 450%	7.5 5	60	371HD132C	\$2862.00	H	—	371HD232C	\$3038.00	H	No
230V	34	Standard-Duty Heavy-Duty	300% 450%	10 7.5	60	371ID132C	\$2862.00	I	—	371ID232C#	\$3317.00	I	Yes
230V	34	Standard-Duty Heavy Duty	300% 400%	10 7.5	60	—	—	—	—	371ID232C ¹	\$3134.00	I	No
230V	48	Standard-Duty Heavy-Duty	300% 450%	15 15	100	371JD132D	\$3440.00	J	—	371JD232D#	\$3698.00	J	Yes
230V	63	Standard-Duty Heavy-Duty	300% 450%	20 20	100	371KD132D	\$3830.00	K	—	371KD232D#	\$4140.00	K	Yes
230V	72	Standard-Duty Heavy-Duty	300% 450%	25 20	100	371LD132D	\$4681.00	L	—	371LD232D#	\$5519.00	L	Yes
230V	105	Standard-Duty Heavy-Duty	300% 450%	30 30	200	371MD132E	\$5714.00	M	—	371MD232E#	\$6900.00	M	Yes
230V	156	Standard-Duty Heavy-Duty	300% 450%	60 50	200	371ND132E	\$7179.00	N	—	371ND232E#	\$8642.00	N	Yes
230V	156	Standard-Duty Heavy-Duty	300% 450%	60 50	400	371ND132F	\$7778.00	N	—	371ND232F#	\$9241.00	N	Yes
230V	240	Standard-Duty Heavy-Duty	300% 450%	75 75	400	371QD132F	\$9328.00	Q	—	371QD232F#	\$11336.00	Q	Yes
230V	315	Standard-Duty Heavy-Duty	300% 450%	125 100	400	371RD132F	\$10228.00	R	—	371RD232F#	\$13516.00	R	Yes
230V	315	Standard-Duty Heavy-Duty	300% 450%	125 100	600	371RD132G	\$10614.00	R	—	371RD232G#	\$13902.00	R	Yes
230V	370	Standard-Duty Heavy-Duty	300% 450%	150 125	600	371SD132G	\$11014.00	S	—	371SD232G#	\$15180.00	S	Yes
460V	14	Standard-Duty Heavy-Duty	300% 450%	7.5 7.5	30	371FD142B	\$2685.00	F	—	371FD242B	\$2919.00	F	No
460V	17	Standard-Duty Heavy-Duty	300% 450%	10 10	30	371GD142B	\$2735.00	G	—	371GD242B	\$2988.00	G	No
460V	22	Standard-Duty Heavy-Duty	300% 450%	15 15	60	371HD142C	\$2785.00	H	—	371HD242C	\$3038.00	H	No
460V	34	Standard-Duty Heavy-Duty	300% 450%	25 20	60	371ID142C	\$2862.00	I	—	371ID242C#	\$3317.00	I	Yes
460V	34	Standard-Duty Heavy Duty	300% 400%	25 20	60	—	—	—	—	371ID242C ¹	\$3134.00	I	No
460V	48	Standard-Duty Heavy-Duty	300% 450%	30 30	100	371JD142D	\$3440.00	J	—	371JD242D#	\$3698.00	J	Yes
460V	63	Standard-Duty Heavy-Duty	300% 450%	40 40	100	371KD142D	\$3830.00	K	—	371KD242D#	\$4140.00	K	Yes
460V	72	Standard-Duty Heavy-Duty	300% 450%	50 40	100	371LD142D	\$4681.00	L	—	371LD242D#	\$5519.00	L	Yes
460V	105	Standard-Duty Heavy-Duty	300% 450%	75 60	200	371MD142E	\$5714.00	M	—	371MD242E#	\$6900.00	M	Yes
460V	156	Standard-Duty Heavy-Duty	300% 450%	125 100	400	371ND142F	\$7778.00	N	—	371ND242F#	\$9241.00	N	Yes
460V	240	Standard-Duty Heavy-Duty	300% 450%	200 150	400	371QD142F	\$9328.00	Q	—	371QD242F#	\$11336.00	Q	Yes
460V	315	Standard-Duty Heavy-Duty	300% 450%	250 200	400	371RD142F	\$10228.00	R	—	371RD242F#	\$13516.00	R	Yes
460V	315	Standard-Duty Heavy-Duty	300% 450%	250 200	600	371RD142G	\$10614.00	R	—	371RD242G#	\$13902.00	R	Yes
460V	370	Standard-Duty Heavy-Duty	300% 450%	300 250	600	371SD142G	\$11014.00	S	—	371SD242G#	\$15180.00	S	Yes

¹27 amps max (SF 1.0)



Publications and Reference: See Section 17 for a complete list of additional product-related publications

Reduced Voltage Starters

Section 2

Solid State

CR373

ASTAT®-CD Plus

Enclosed Combination

Mag-Break Type®

List Price includes ASTAT®-CD Plus solid state reduce voltage starter, in the enclosure selected, with a Mag-breaker operated by a side-mounted handle that indicates status as ON in the up position and OFF in the down position. The operating handle prevents entrance into the enclosure when the switch is in the ON position, unless the defeater mechanism is deliberately operated. The handle accepts up to 3 padlocks for securing the switch in the OFF position for maintenance shutdown. Provisions also are made for padlocking the handle in the ON position for continuous process applications requiring supervised shutdown. **Starters for 200, 230 and 460 volt motors are supplied with a control circuit transformer with 2 primary fuses and 1 secondary fuse.** Interposing relay supplied with 1 extra normally open and 1 extra normally closed contact for optional user requirements. On starter sizes F-S, box lug terminals are supplied for line and load field power connections; on starter sizes T-V, order box lug terminal kits separately (see page 2-32).

Product Number Selection Instructions

1. Product numbers with # are incomplete. For starter sizes J and above in 12/3R enclosures, add one product number digit (in place of #) for overload relay current range for bypass contactor. Overload relay not included in pricing; add appropriate List Price Adder from Overload Relay Table (page 2-44).

Example:

To specify a combination starter used with a 460 V motor rated at 30 hp and a full load current of 40 amps in a Type 12 enclosure, select base product number CR373JD242F2#.

Replace # with overload relay digit "E" from table, page 2-44. Complete product number is CR373JD242FE.

List Price **\$3652.00**

Overload Adder **\$95.00**

Total List Price, GO-10A6 **\$3747.00**

2. Product Notes

When operating motors at service factor loads, service factor amps must not exceed starter rating. Enclosed starters rated for 40°C ambient temperatures, derate rated controller current by 1.5%/°C above 40°C, up to a maximum of 50°C.

Three-Phase

Volts	Current Rating Amps (AC-3)	Standard-Duty Heavy-Duty	Max. Nominal Current for 30 sec.	Motor Horsepower	Circuit Interrupter Rating (Amps)	NEMA Type 1				NEMA Type 12/3R			
						Product Number CR	List Price GO-10A6	Starter Size	Bypass Contactor	Product Number CR	List Price GO-10A6	Starter Size	Bypass Contactor
200V	14	Standard-Duty Heavy-Duty	300% 450%	3 3	15	373FD122D	\$2720.00	F	—	373FD222D	\$2954.00	F	No
200V	17	Standard-Duty Heavy-Duty	300% 450%	3 3	15	373GD122D	\$2770.00	G	—	373GD222D	\$3023.00	G	No
200V	22	Standard-Duty Heavy-Duty	300% 450%	5 5	30	373HD122E	\$2820.00	H	—	373HD222E	\$3073.00	H	No
200V	34	Standard-Duty Heavy-Duty	300% 450%	10 7.5	30	373ID122E	\$2870.00	I	—	373ID222E#	\$3325.00	I	Yes
200V	34	Standard-Duty Heavy-Duty	300% 400%	10 7.5	30	—	—	—	—	373ID222E ¹	\$3142.00	I	No
200V	48	Standard-Duty Heavy-Duty	300% 450%	15 10	50	373JD122F	\$3394.00	J	—	373JD222F2#	\$3652.00	J	Yes
200V	48	Standard-Duty Heavy-Duty	300% 450%	15 10	100	373JD122G	\$3409.00	J	—	373JD222G2#	\$3667.00	J	Yes
200V	63	Standard-Duty Heavy-Duty	300% 450%	20 15	100	373KD122G	\$3799.00	K	—	373KD222G2#	\$4109.00	K	Yes
200V	72	Standard-Duty Heavy-Duty	300% 450%	20 20	100	373LD122G	\$4650.00	L	—	373LD222G2#	\$5488.00	L	Yes
200V	105	Standard-Duty Heavy-Duty	300% 450%	30 30	150	373MD122H	\$5501.00	M	—	373MD222H2#	\$6687.00	M	Yes
200V	156	Standard-Duty Heavy-Duty	300% 450%	50 40	150	373ND122H	\$6966.00	N	—	373ND222H2#	\$8429.00	N	Yes
200V	156	Standard-Duty Heavy-Duty	300% 450%	50 40	225	373ND122J	\$7379.00	N	—	373ND222J2#	\$8842.00	N	Yes
200V	240	Standard-Duty Heavy-Duty	300% 450%	75 60	225	373QD122J	\$8929.00	Q	—	373QD222J2#	\$10937.00	Q	Yes
200V	240	Standard-Duty Heavy-Duty	300% 450%	75 60	400	373QD122K	\$9498.00	Q	—	373QD222K2#	\$11506.00	Q	Yes
200V	315	Standard-Duty Heavy-Duty	300% 450%	100 75	400	373RD122K	\$10398.00	R	—	373RD222K2#	\$13686.00	R	Yes
200V	370	Standard-Duty Heavy-Duty	300% 450%	125 100	400	373SD122K	\$10798.00	S	—	373SD222K2#	\$14964.00	S	Yes
200V	370	Standard-Duty Heavy-Duty	300% 450%	125 100	600	373SD122L	\$11289.00	S	—	373SD222L2#	\$15455.00	S	Yes
200V	500	Standard-Duty Heavy-Duty	300% 450%	150 150	600	373TD122L	\$15700.00	T	—	373TD222L2#	\$20705.00	T	Yes
200V	630	Standard-Duty Heavy-Duty	300% 450%	200 200	700	373UD122M	\$18770.00	U	—	373UD222M2#	\$25650.00	U	Yes
200V	850	Standard-Duty Heavy-Duty	300% 450%	300 250	800	373VD122N ²	\$24900.00	V	—	373VD222N2# ²	\$38978.00	V	Yes
200V	850	Standard-Duty Heavy-Duty	300% 450%	300 250	1200	373VD122R ²	\$24900.00	V	—	373VD222R2# ²	\$38978.00	V	Yes

¹27 amps max (SF 1.0).

²Heavy-Duty 800 amps max.

Reduced Voltage Starters
Solid State
CR373
ASTAT®-CD Plus
 Enclosed Combination
 Mag-Break Type®

Three-Phase

Volts	Current Rating Amps (AC-3)	Standard-Duty Heavy Duty	Max. Nominal Current for 30 sec.	Motor Horsepower	Circuit Interrupter Rating (Amps)	NEMA Type 1				NEMA Type 12/3R			
						Product Number CR	List Price GO-10A6	Starter Size	Bypass Contactor	Product Number CR	List Price GO-10A6	Starter Size	Bypass Contactor
230V	14	Standard-Duty Heavy-Duty	300% 450%	3 3	15	373FD132D	\$2720.00	F	—	373FD232D	\$2964.00	F	No
230V	17	Standard-Duty Heavy-Duty	300% 450%	3 3	15	373GD132D	\$2770.00	G	—	373GD232D	\$3023.00	G	No
230V	22	Standard-Duty Heavy-Duty	300% 450%	7.5 5	30	373HD132E	\$2820.00	H	—	373HD232E	\$3073.00	H	No
230V	34	Standard-Duty Heavy-Duty	300% 450%	10 7.5	30	373ID132E	\$2870.00	I	—	373ID232E#	\$3325.00	I	Yes
230V	34	Standard-Duty Heavy Duty	300% 400%	10 7.5	30	—	—	—	—	373ID232E ¹	\$3142.00	I	No
230V	48	Standard-Duty Heavy-Duty	300% 450%	15 15	50	373JD132F	\$3394.00	J	—	373JD232F#	\$3652.00	J	Yes
230V	63	Standard-Duty Heavy-Duty	300% 450%	20 20	100	373KD132G	\$3799.00	K	—	373KD232G#	\$4109.00	K	Yes
230V	72	Standard-Duty Heavy-Duty	300% 450%	25 20	100	373LD132G	\$4650.00	L	—	373LD232G#	\$5488.00	L	Yes
230V	105	Standard-Duty Heavy-Duty	300% 450%	30 30	100	373MD132G	\$5480.00	M	—	373MD232G#	\$6668.00	M	Yes
230V	156	Standard-Duty Heavy-Duty	300% 450%	60 50	225	373ND132J	\$7379.00	N	—	373ND232J#	\$8842.00	N	Yes
230V	240	Standard-Duty Heavy-Duty	300% 450%	75 75	400	373QD132K	\$9498.00	Q	—	373QD232K#	\$11506.00	Q	Yes
230V	315	Standard-Duty Heavy-Duty	300% 450%	125 100	400	373RD132K	\$10398.00	R	—	373RD232K#	\$13686.00	R	Yes
230V	370	Standard-Duty Heavy-Duty	300% 450%	150 125	400	373SD132K	\$10798.00	S	—	373SD232K#	\$14964.00	S	Yes
230V	370	Standard-Duty Heavy-Duty	300% 450%	150 125	600	373SD132L	\$11289.00	S	—	373SD232L#	\$15455.00	S	Yes
230V	500	Standard-Duty Heavy-Duty	300% 450%	200 150	500	373TD132K	\$15700.00	T	—	373TD232K#	\$20705.00	T	Yes
230V	500	Standard-Duty Heavy-Duty	300% 450%	200 150	600	373TD132L	\$15700.00	T	—	373TD232L#	\$20705.00	T	Yes
230V	630	Standard-Duty Heavy-Duty	300% 450%	250 200	600	373UD132L	\$18770.00	U	—	373UD232L#	\$25650.00	U	Yes
230V	630	Standard-Duty Heavy-Duty	300% 450%	250 200	800	373UD132N	\$18770.00	U	—	373UD232N#	\$25650.00	U	Yes
230V	850	Standard-Duty Heavy-Duty	300% 450%	350 300	1000	373VD132P ²	\$24900.00	V	—	373VD232P# ²	\$38978.00	V	Yes
230V	850	Standard-Duty Heavy-Duty	300% 450%	350 300	1200	373VD132R ²	\$24900.00	V	—	373VD232R# ²	\$38978.00	V	Yes

¹27 amps max (SF 1.0).

²Heavy-Duty 800 amps max.



Publications and Reference: See Section 17 for a complete list of additional product-related publications

Reduced Voltage Starters

Section 2

Solid State

CR373

ASTAT®-CD Plus

Enclosed Combination

Mag-Break Type®

Product Number Selection Instructions

1. Product numbers with # are incomplete. For starter sizes J and above in 12/3R enclosures, add one product number digit (in place of #) for overload relay current range for bypass contactor. Overload relay not included in pricing; add appropriate List Price Adder from Overload Relay Table (page 2-44).

Example:

To specify a combination starter used with a 460 V motor rated at 30 hp and a full load current of 40 amps in a Type 12 enclosure, select base product number CR373JD242F2#.

Replace # with overload relay digit "E" from table, page 2-44.

Complete product number is CR373JD242F2E.

List Price \$3652.00

Overload Adder \$95.00

Total List Price, GO-10A6 \$3747.00

2. Product Notes

When operating motors at service factor loads, service factor amps must not exceed starter rating. Enclosed starters rated for 40°C ambient temperatures, derate rated controller current by 1.5%/°C above 40°C, up to a maximum of 50°C.

Three-Phase

Volts	Current Rating Amps (AC-3)	Standard-Duty Heavy Duty	Max. Nominal Current for 30 sec.	Motor Horsepower	Circuit Interrupter Rating (Amps)	NEMA Type 1				NEMA Type 12/3R			
						Product Number CR	List Price GO-10A6	Starter Size	Bypass Contactor	Product Number CR	List Price GO-10A6	Starter Size	Bypass Contactor
460V	14	Standard-Duty Heavy-Duty	300% 450%	7.5 7.5	15	373FD142D	\$2720.00	F	—	373FD242D	\$2954.00	F	No
460V	17	Standard-Duty Heavy-Duty	300% 450%	10 10	30	373GD142E	\$2770.00	G	—	373GD242E	\$3023.00	G	No
460V	22	Standard-Duty Heavy-Duty	300% 450%	15 15	30	373HD142E	\$2820.00	H	—	373HD242E	\$3073.00	H	No
460V	34	Standard-Duty Heavy-Duty	300% 450%	25 25	50	373ID142F	\$2905.00	I	—	373ID242F#	\$3325.00	I	Yes
460V	34	Standard-Duty Heavy Duty	300% 400%	25 25	50	—	—	—	—	373ID242F1	\$3177.00	I	No
460V	48	Standard-Duty Heavy-Duty	300% 450%	30 30	50	373JD142F	\$3394.00	J	—	373JD242F#	\$3652.00	J	Yes
460V	63	Standard-Duty Heavy-Duty	300% 450%	40 40	100	373KD142G	\$3799.00	K	—	373KD242G#	\$4109.00	K	Yes
460V	72	Standard-Duty Heavy-Duty	300% 450%	50 40	100	373LD142G	\$4650.00	L	—	373LD242G#	\$5488.00	L	Yes
460V	105	Standard-Duty Heavy-Duty	300% 450%	75 60	150	373MD142H	\$5501.00	M	—	373MD242H#	\$6687.00	M	Yes
460V	156	Standard-Duty Heavy-Duty	300% 450%	125 100	150	373ND142H	\$6966.00	N	—	373ND242H#	\$8429.00	N	Yes
460V	156	Standard-Duty Heavy-Duty	300% 450%	125 100	225	373ND142J	\$7379.00	N	—	373ND242J#	\$8842.00	N	Yes
460V	240	Standard-Duty Heavy-Duty	300% 450%	200 150	400	373QD142K	\$9498.00	Q	—	373QD242K#	\$11506.00	Q	Yes
460V	315	Standard-Duty Heavy-Duty	300% 450%	250 200	400	373RD142K	\$10398.00	R	—	373RD242K#	\$13686.00	R	Yes
460V	315	Standard-Duty Heavy-Duty	300% 450%	250 200	600	373RD142L	\$10889.00	R	—	373RD242L#	\$14177.00	R	Yes
460V	370	Standard-Duty Heavy-Duty	300% 450%	300 250	600	373SD142L	\$11289.00	S	—	373SD242L#	\$15455.00	S	Yes
460V	500	Standard-Duty Heavy-Duty	300% 450%	400 350	600	373TD142L	\$15700.00	T	—	373TD242L#	\$20705.00	T	Yes
460V	630	Standard-Duty Heavy-Duty	300% 450%	500 400	700	373UD142M	\$18770.00	U	—	373UD242M#	\$25650.00	U	Yes
460V	630	Standard-Duty Heavy-Duty	300% 450%	500 400	800	373UD142N	\$18770.00	U	—	373UD242N#	\$25650.00	U	Yes
460V	850	Standard-Duty Heavy-Duty	300% 450%	700 600	1000	373VD142P ²	\$24900.00	V	—	373VD242P# ²	\$38978.00	V	Yes
460V	850	Standard-Duty Heavy-Duty	300% 450%	700 600	1200	373VD142R ²	\$24900.00	V	—	373VD242R# ²	\$38978.00	V	Yes

¹27 amps max (SF 1.0).

²Heavy-Duty 800 amps max.

Reduced Voltage Starters Solid State

CR370, CR371, CR373

ASTAT®-CD Plus

Enclosed

Factory Installed Modifications

Use this section to select starters with factory-installed modifications not available in the general selection tables. It provides a step-by-step method for arriving at the product numbers and list prices for starters with those modifications.

First, select your basic enclosed starter from pages 2-33 to 2-40. Fill in the digits of the product number selected in the appropriate boxes of the base unit product number line below and enter the base list price in the appropriate price box. Then, to select additional modifications, follow the step-by-step instructions.

As instructed, transfer the resulting product number digits to the new product number digits line and the price component for your selection to the appropriate price boxes. (Make copies of this blank form for future use).

When you're done, your complete product number will be your base unit product number, with all digits from the new product number digits line replacing or adding to the original digits. Your total **List Price, GO-10A6**, will be the sum of the amounts in the boxes in the price line.

Product Number

If no other options are required, complete only Steps 1-3 (or Steps 1-2 for noncomb. starters)										Omit this digit for noncomb. starters	Complete Steps 4-8 when further options are required.						
										1	2	3	4	5	6	7	8
Base unit product number	C	R	3	7										#			
New product number digits																	
	Starter Type		Frame Size			Design	Enclosure Type	Line Volts and Rectifier Fuses	Control Circuit Options	Fuse and Circuit Breaker Ratings	Contactors Options	Separate Overload	Pilot Device Options	Auxiliary Contacts and Relays	Meter Options		

Price

\$		+	\$		+	\$		+	\$	0	+	\$		+	\$		=	\$		=	\$		=	\$		=	\$	

Base Price from pages 2-33 to 2-40

Omit for noncomb. starters

Total List Price, GO-10A6

Example

ASTAT®-CD Plus solid state reduced voltage starter for a 200 hp, 460 volt motor (229 motor FLA) for a conveyor. Fused disconnect combination starter in NEMA Type 12 enclosure with 120V secondary CPT, dual primary fuses, external elapsed time meter and START push button, H-O-A selector switch and red RUN light.

Select base unit from table on page 2-37. Enter product number CR371RD242F2# and **\$13,516.00 Base Price** in spaces provided.

- Select line volts and rectifier fuses. None required. Make no change to product number box 1 and enter \$0 in price box 1.
- Select control circuit options. None required because CPT is standard on combination starters. Make no change to product number box 2 and enter \$0 in price box 2.
- No change.
- Select contactor options. None required because bypass contactor is included with unit selected. Make no change to product number box 4 and enter \$0 in price box 4.
- Select overload relay. Enter P in product number box 5 and \$590 in price box 5.
- Select pilot device options. Enter R in product number box 6 and \$265 in price box 6.
- Select auxiliary contacts and relays. No additional contacts or relays required. Enter 0 in product number box 7 and \$0 in price box 7.
- Select meter options. Enter F in product number box 8 and \$275 in price box 8.

Product Number

If no other options are required, complete only Steps 1-3 (or Steps 1-2 for noncomb. starters)										Omit this digit for noncomb. starters	Complete Steps 4-8 when further options are required.						
										1	2	3	4	5	6	7	8
Base unit product number	C	R	3	7	1	R	D	2	4	2	F	2	#				
New product number digits													P	R	0	F	
	Starter Type		Frame Size			Design	Enclosure Type	Line Volts and Rectifier Fuses	Control Circuit Options	Fuse and Circuit Breaker Ratings	Contactors Options	Separate Overload	Pilot Device Options	Auxiliary Contacts and Relays	Meter Options		

Price

\$	13516.00	+	\$	0	+	\$	0	+	\$	0	+	\$		+	\$	590.00	=	\$	265.00	=	\$	0	=	\$	275.00	=	\$	14646.00

Base Price from pages 2-33 to 2-40

Omit for noncomb. starters

Assemble new, complete product number: CR371RD242F2P0F. Total list price adders: **\$14,646.00, List Price, GO-10A6.**



Publications and Reference: See Section 17 for a complete list of additional product-related publications

Reduced Voltage Starters Solid State

CR370, CR371, CR373

ASTAT®-CD Plus

Enclosed

Factory Installed Modifications

1 Select line volts and rectifier fuses

Select line volts and, if desired, rectifier fuses by frame size. Transfer the product number digit to box 1 in the "new product number digits" line and the price to box 1 in the price line.

Rectifier Fuses	Frame size	Product No. Digit by Line Volts			List Price Adder, GO-10A6	
		200/208 V	230 V	460 V		
No	F-V	2	3	4	—	
	F-I	6	7	8	\$260.00	
	J-K	6	7	8	\$320.00	
	L-M	6	7	8	\$475.00	
	Yes	N-Q	6	7	8	\$625.00
		R-S	6	7	8	\$1260.00
		T	6	7	8	\$1500.00
		U	6	7	8	\$3000.00
	V	6	7	8	\$3500.00	

2 Select control circuit options

Select control circuit options by frame size. Transfer the product number digit to box 2 in the "new product number digits" line and the price to box 2 in the price line.

Frame Size	Product No. Digit (Replaces #)	Control Circuit	VA	List Price Adder, GO-10A6	
				Noncombination Starters	Combination Starters ¹
F-I	0	Control voltage from power lines L1 & L2 (240 V only)	—	—	\$(160.00)
	1	120 V separate control	—	—	\$(160.00)
	2	CPT standard capacity	50	\$160.00	—
	3	CPT 100VA extra capacity	150	\$225.00	\$65.00
J-Q	0	Control voltage from power lines L1 & L2 (240 V only)	—	—	\$(190.00)
	1	120 V separate control	—	—	\$(190.00)
	2	CPT standard capacity	100	\$190.00	—
	3	CPT 100VA extra capacity	250	\$285.00	\$93.00
R-T	0	Control voltage from power lines L1 & L2 (240 V only)	—	—	\$(270.00)
	1	120 V separate control	—	—	\$(270.00)
	2	CPT standard capacity	150	\$225.00	—
	3	CPT 100VA extra capacity	250	\$285.00	\$60.00
U-V	0	Control voltage from power lines L1 & L2 (240 V only)	—	—	\$(200.00)
	1	120 V separate control	—	—	\$(250.00)
	2	CPT standard capacity	250	\$285.00	—
	3	CPT 100VA extra capacity	375	\$355.00	\$70.00

¹Standard capacity CPT is included in the base price for combination starters listed in the general selection tables on pages 2-33 to 2-40.

Reduced Voltage Starters
Solid State
CR370, CR371, CR373
ASTAT®-CD Plus
 Enclosed
 Factory Installed Modifications

3 Fuse and circuit breaker ratings reference table

For reference only. For combination starters, the product number digit is included in the number brought forward from the general selection tables on pages 2-33 to 2-40. For noncombination starters, skip this step and omit the corresponding digit in your product number. If no further factory-installed modifications are desired, you may stop after this step and you will have built a valid and complete product number and list price for all Type 1 enclosed starters and all Type 12/3R enclosed starters in frame sizes F-I.

Product No. Digit	Combination, Fusible Disconnect (CR371)		Combination, Mag-Break Circuit Breaker (CR373), Frame Sizes F-S		Combination, Mag-Break Circuit Breaker (CR373), Frame Sizes T-V	
	Frame Size	Class J Fuse/Fuse Clip Rating (Amps)	Frame Size	Circuit Breaker Rating (Amps)	Frame Size	Circuit Breaker Rating (Amps)
A	F-V	unfused	—	—	—	—
B	F-I	30	—	—	—	—
C	H-J	60	F	7	—	—
D	J-M	100	F-G	15	—	—
E	M-N	200	G-I	30	—	—
F	M-R	400	I-J	50	—	—
G	R-S	600	J-M	100	—	—
H	—	—	M-N	150	—	—
J	—	—	N-Q	225	—	—
K	—	—	Q-S	400	T	500
L	—	—	R-S	600	T-U	600
M	—	—	—	—	U-V	700
N	—	—	—	—	U-V	800
P	—	—	—	—	U-V	1000
R	—	—	—	—	U-V	1200

4 Select contactor options

Bypass contactors are required for enclosed starters with frame sizes J or larger in Type 12/3R enclosures and are included in the base price of frame size J starters or larger in Type 12 enclosure. Any option including a bypass contactor requires that you also select an overload relay from table 5 below.

Select contactor options. Transfer the product number digit to box 4 in the “new product number digits” line and the price for your frame size to box 4 in the price line.

Product No. Digit	0		1		2		3		4		5		7		8	
	None		Isolation		Bypass		DC Brake		Isolation+Bypass		Isolation+DC Brake		Maintenance Bypass w/Manual Switch		Isolation+ Maintenance Bypass w/Manual Switch	
Enclosure Type	1,12/3R		1, 12/3R		1, 12/3R		1, 12/3R		1, 12/3R		1, 12/3R		1 ¹ , 12/3R		1 ¹ , 12/3R	
Frame Size	List Price Adder GO-10A6, by Frame Size	List Price Adder GO-10A6, by Frame Size	List Price Adder GO-10A6, by Frame Size		List Price Adder GO-10A6, by Frame Size	List Price Adder GO-10A6, by Frame Size		List Price Adder GO-10A6, by Frame Size	List Price Adder GO-10A6, by Frame Size		List Price Adder GO-10A6, by Frame Size	List Price Adder GO-10A6, by Frame Size		List Price Adder GO-10A6, by Frame Size		
F	-	\$145.00	\$145.00	\$145.00	\$145.00	\$290.00	\$290.00	\$290.00	\$545.00	\$545.00	\$690.00	\$690.00				
G	-	\$164.00	\$164.00	\$164.00	\$164.00	\$328.00	\$328.00	\$328.00	\$564.00	\$563.00	\$728.00	\$728.00				
H	-	\$183.00	\$183.00	\$183.00	\$183.00	\$366.00	\$366.00	\$366.00	\$583.00	\$583.00	\$766.00	\$766.00				
I	-	\$183.00	\$183.00	\$183.00	\$183.00	\$366.00	\$366.00	\$366.00	\$583.00	\$400.00	\$766.00	\$766.00				
J	-	\$275.00	\$275.00	*	\$208.00	\$550.00	\$275.00	\$483.00	\$675.00	\$400.00	\$883.00	\$675.00				
K	-	\$275.00	\$325.00	*	\$208.00	\$600.00	\$275.00	\$483.00	\$725.00	\$400.00	\$883.00	\$675.00				
L	-	\$325.00	\$363.00	*	\$275.00	\$688.00	\$325.00	\$600.00	\$763.00	\$400.00	\$1000.00	\$725.00				
M	-	\$416.00	\$591.00	*	\$275.00	\$1007.00	\$416.00	\$691.00	\$991.00	\$400.00	\$1091.00	\$816.00				
N	-	\$738.00	\$738.00	*	\$325.00	\$1476.00	\$738.00	\$1063.00	\$1138.00	\$400.00	\$1463.00	\$1138.00				
Q	-	\$1283.00	\$1283.00	*	\$1256.00	\$2566.00	\$1283.00	\$2539.00	\$1683.00	\$400.00	\$2939.00	\$1683.00				
R	-	\$2363.00	\$2363.00	*	\$1256.00	\$4726.00	\$2363.00	\$3619.00	\$2763.00	\$400.00	\$4019.00	\$2763.00				
S	-	\$3241.00	\$3241.00	*	\$1256.00	\$6482.00	\$3241.00	\$4497.00	\$3641.00	\$400.00	\$4897.00	\$3641.00				
T	-	\$4700.00	\$4700.00	*	\$1762.00	\$9400.00	\$4700.00	\$6462.00	\$5100.00	\$400.00	\$6862.00	\$5100.00				
U	-	\$6450.00	\$6450.00	*	\$3241.00	\$12900.00	\$6450.00	\$9691.00	\$6850.00	\$400.00	\$10091.00	\$6850.00				
V	-	\$13428.00	\$13428.00	*	\$3241.00	NA	NA	NA	\$13828.00	\$400.00	NA	NA				

*Bypass included in base price for Type 12/3R.

¹Overload relay required in maintenance bypass mode, include overload relay in Step 5



Publications and Reference: See Section 17 for a complete list of additional product-related publications

Reduced Voltage Starters Solid State

CR370, CR371, CR373

ASTAT®-CD Plus

Enclosed

Factory Installed Modifications

7 Select Auxiliary Contacts and Relays (1NO-1NC standard)

Select auxiliary contacts and relays. Transfer the product number digit to box 7 in the “new product number digits” line and the price to box 7 in the price line.

Product No. Digit	Extra Relays	3NO-1NC	2NO-2NC	1NO-3NC	List Price Adder, GO-10A6
0		None			—
1	1	•			\$62.00
2	1		•		\$62.00
3	1			•	\$62.00
5 ¹	2	•			\$124.00
6 ¹	2		•		\$124.00
7 ¹	2			•	\$124.00

¹Not available with bypass.

8 Select Meter Options

Select meter options. Transfer the product number digit to box 8 in the “new product number digits” line and the price to box 8 in the price line.

Product No. Digit	1-Phase ² Ammeter	1-Phase ² Voltmeter	3-Phase Ammeter	3-Phase Voltmeter	Elapsed ² Time Meter	List Price Adder, GO-10A6
A			None			—
B	•					\$750.00
C		•				\$750.00
D			•			\$960.00
E				•		\$960.00
F					•	\$275.00
G	•	•				\$1500.00
H	•			•		\$1710.00
J	•				•	\$1025.00
K			•			\$1710.00
L		•			•	\$1025.00
M			•	•		\$1920.00
N			•		•	\$1235.00
P				•	•	\$1235.00
R	•	•			•	\$1775.00
S	•			•	•	\$1985.00
T		•	•		•	\$1985.00
W			•	•	•	\$2195.00

²Single phase ammeter, voltmeter and elapsed time meter function is included as a digital readout on the ASTAT display. For external separate analog meter, select product number digit shown in the table above.



Reduced Voltage Starters Solid State

QC2 ASTAT®-CD Plus Technical Specifications

Section 2

General Specifications

Volts Rating	3ph AC Systems - Up to 500V
Frequency	50/60 - Hz - Control range Of 45-65 Hz

Control Specifications

Control System	Digital system with microcontroller Starting ramp with progressive increase in voltage and current limitation
Initial Voltage (Pedestal)	% - 30-95 U_n
Initial (Starting) Torque	% - 10-90 $M_{direct\ start}$
Kick Start	% - 95 U_n (90% $M_{direct\ start}$), adjustable 0 to 999 ms
Motor Unit Ratio (N)	0.4 to 1.2
Current Limit (Starting)	Adjustable from 1 to 4.5 (I_r/I_n) max. 7.0 I_n
Acceleration Ramp Time	s - 1 to 99 (types: standard or linear ramp up)
Energy Savings	Output voltage reduction according to power factor
Override	Fixed output voltage permanently equal to supply voltage
Bypass	Direct control of a bypass contactor
Brake Time by Ramp	s - 1 to 120 (1 to 99 in secondary ramp) adjustable independently of starting ramp time (types: standard, pump control or linear ramp down)
DC Braking	0 to 99 s; 0.0 to 2.5 $\times I_n$
Slow Speed	Direct torque: 7% or 14% of nominal speed; reverse torque: 20% of nominal speed
Retry	0 to 4 attempts, and 1 to 99 sec. retry time
Monitoring	Motor current, line voltage (L1 voltage is monitored to provide this protection), power, power factor and elapsed time

Running

External Control	Start-Stop
Acceleration Phase	Adjustable time
Permanent Phase	Energy savings/Override choice
Stop Phase	Power cut-off/Ramp/DC braking/Pump control

Inputs/Outputs

Inputs	4 digital optocoupled. Two fixed (Start, Stop), and 2 programmable (I3, I4) 1 Analog 0-5VDC for Tachogenerator feedback input
Outputs	3 programmable relays (1r, 2r, 3r) 1 Analog 0-10VDC output for current metering

Protections

Current Limit	Adjustable from 1 to 4.5 (I_r/I_n) max. 7.0 I_n
Overload	IEC class 10 and 20; NEMA class 10, 20 and 30 all selectable
Cool-down Time after Overload Trip	s - 300 for reset
Loss on Input Phase	s - Trip at 3
Thyristor Short Circuit	ms - Trip at 200
Heatsink Overheating	ms - Trip at 200
Motor Thermistor	ms - Trip at 200 if thermistor impedance > response value
Loss on Output Phase	s - Trip at 3
Stalled Rotor	ms - Trip at 200
Supply Frequency Error	Hz - If $f < 45$ or $f > 65$, will not start
Overcurrent	100 to 150% I_n ; trip time adjustable from 0 to 99 sec.
Undercurrent	0 to 99% I_n ; trip time adjustable from 0 to 99 sec.
Overvoltage	100 to 130% U_n ; trip time adjustable from 0 to 99 sec. (L1 voltage is monitored to provide this protection.)
Undervoltage	0 to 50% U_n ; trip time adjustable from 0 to 99 sec. (L1 voltage is monitored to provide this protection.)
Error (CPU)	ms - 60
Memory	4 former errors
Long Start Time	s - 2 $\times t_a$ (t_a = acceleration ramp time)
Long Slow Speed Time	s - 120

Environmental Conditions

Operation Temperature	°C - 0 to +55 (derate output current by 1.5%/°C above 40°C)
Relative Humidity	% - 95% without condensation
Maximum Altitude	m - 3000 (derate output current by 1%/100m above 1000m)
Mounting Position	Vertical
Protection Degree	IP00, UL Open

Standards

CE, cUL, UL	CE Conforming IEC 947-4-2; UL, cUL conforming to UL508, UL File E 153901 (open), 100757 (enclosed)
Conducted & Radiated emissions	Conforming IEC 947-4-2, Class A
Electrostatic discharges	Conforming to IEC 1000-4-2, level 3
Radioelectric interference	Conforming to IEC 1000-4-6, level 3 and to IEC 1000-4-3, level 3
Immunity to fast transients	Conforming to IEC 1000-4-4, level 3
Immunity to Surge Voltage	Conforming to IEC 1000-4-5, level 3

L1 voltage is monitored to provide this protection.

ASTAT®-CD Losses

Frame	Control Circuit (watts)	Power Circuit (watts)	Bypass Contactor Inrush (va)	Bypass Contactor Holding (va)
F	15	41	45	6
G	15	50	45	6
H	15	59	45	6
I	15	92	88	9
J	47	131	88	9
K	47	189	88	6
L	47	210	191	17
M	47	277	191	17
N	67	524	191	17
Q	67	834	350	20
R	93	970	350	20
S	93	1043	350	20
T	93	1721	425	20
U	183	1832	750	25
V	183	2377	750	25
X	183	3310	1600	210

Control circuit losses includes cooling fan power
Bypass contactor used with selected enclosed forms

Reduced Voltage Starters

Solid State

QC2

ASTAT®-CD Plus

Technical Specifications

I/O Terminal Board Specifications

Power I/O Terminals

Terminal	Function	Description
1L1, 3L2, 5L3	Mains Input	3ph input voltage, 200 - 480 Volts QC2xxx type
2T1, 4T2, 6T3	Motor Output	Output terminals to 3ph AC motor
A1, A2, B1, B2	Input Control Voltage	110/120V AC, +10%, -15%

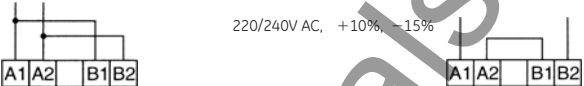

Digital Inputs

Terminal	Function	Description
57	Common for digital inputs	This is a common terminal for digital input terminals specified below.
1	Run	Run order. Command signal may be provided by one NO dry momentary contact to terminals 1 and 57.
2	Stop	Stop order. Command signal may be provided by one NC dry momentary contact to terminals 2 and 57.
3	Programmable input I3	These two inputs are programmable. Can be assigned to the following internal functions
4	Programmable input I4	

soft stop
pump control
kick start
override

DC brake
slow speed control
reverse slow speed
local/remote control

linear ramp
dual ramp selection
bypass function

Command signal should be provided by one NC dry contact to terminals 57-3 or terminals 57-4. By switching this contact ON/OFF it is possible to enable or disable the assigned function.

Digital Outputs

Terminal	Function	Description
11, 12, 14	Programmable relay 1r	11-12 = NC, 11-14 = N.O. dry contacts. This relay can be assigned to several internal output functions. As default assigned to function RUN.
23, 24	Programmable relay 2r	23-24 = N.O. dry contact. This relay can be assigned to several internal output functions. As default assigned to function EOR.
33, 34	Programmable relay 3r	33-34 = N.O. dry contact. This relay can be assigned to several internal output functions. As default assigned to function DC BRAKE.

Common for all relay output contacts

Maximum usage voltage: 380VAC (B300-UL)

Thermal current: 8A

AC-15 use: 220V/3A, 380V/1A

DC-15 use: 30V max/3.5A

Analog I/O

Terminal	Function	Description
8	Analog input common (-)	This is a common terminal for the analog input terminal number 7 and analog output terminal number 9.
7	TG feedback input (+)	
9	Current Output (+)	0-5V analog input for speed feedback. It should be provided by a DC tachogenerator coupled to the motor. This speed feedback signal is required when the "linear ramp" function is used. 0-10V DC analog Output for current measurement purpose ($1 \times I_L = 2V$ DC output) Load Impedance 10K Ω or higher

Motor Thermistor Terminals

Terminal	Function	Description
5, 6	Motor thermistor input	This input allows a motor thermistor with a response value from 2.8 to 3.2K Ω , and a reset value from 0.75 to 1K Ω to control motor temperature. When the motor thermistor is not used, a link must be used between terminals 5-6.

Communications

Terminal	Function	Description
TD, RD, SG	Tx, Rx, or data	RS232C, 3 wires, half duplex. Maximum cable length 3 meters (10 feet) Asynchronous data transmission, 9600 Bauds, 1 bit start, 8 bits data, 2 bits stop, no parity.

Abbreviations

I	Actual measured motor current
I_m	Maximum starting current desired
I_n	Nominal motor nameplate FLA
I_r	ASTAT® rated nameplate FLA
I_L	Current limit for starting I_m/I_r
I_{Lmax}	Current limit for starting I_m/I_r
$T_{direct\ start}$	Full voltage starting torque
N	L_r/L_r
SF	Service factor
U_n	Full line voltage

Publications and Reference: See Section 17 for a complete list of additional product-related publications



Reduced Voltage Starters

Solid State

QC2

ASTAT®-CD Plus

Technical Specifications
Thermal Characteristics

IEC Class 10

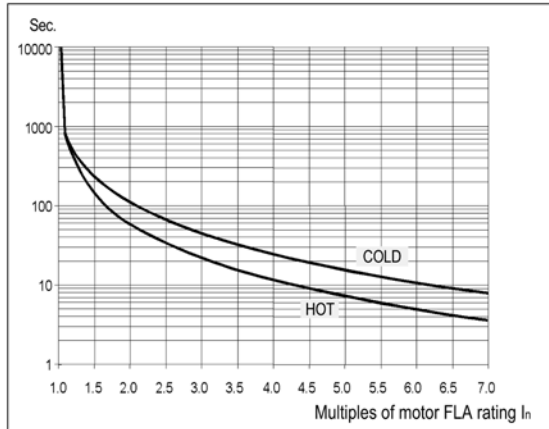

IEC Class 20

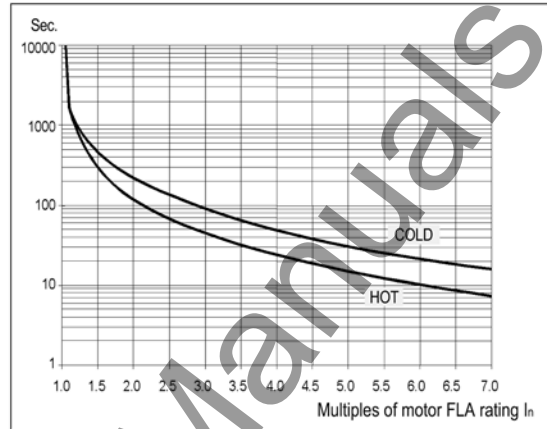

NEMA 10

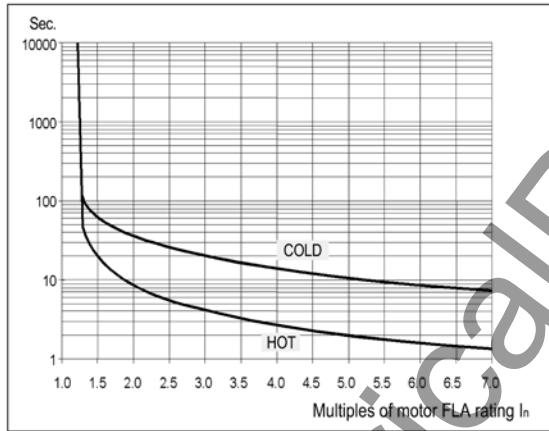

NEMA 20

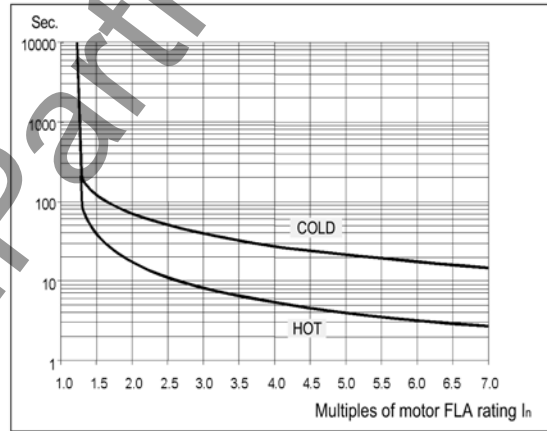

NEMA 30

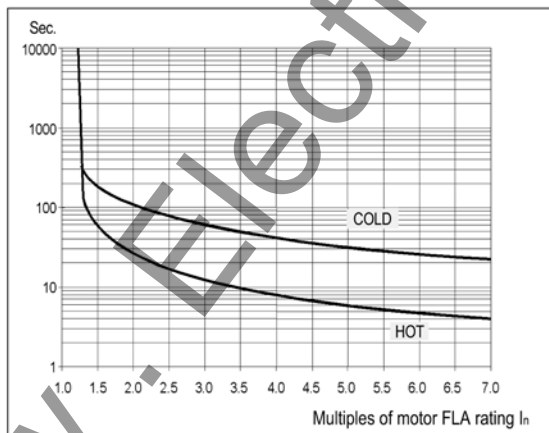

Thermal memory:

If the control voltage is not removed, the unit has a cool down characteristic. The time for cool down is 300 sec. after the overload trip. If the control voltage is removed after tripping, you must wait at least 2 minutes before the unit can be restarted.

Operations per hour:

Using a cycle T, with starting time of t_1 , running time of $T-2t_1$ at rated current and OFF time of t_1 sec. (minimum), the ASTAT-CD Plus allows the following operations per hour.

Starting Current	Operations / Hour. Starting time $t_1=10$ sec.	Operations / Hour Starting time $t_1=20$ sec.
2 Ir	180	90
3 Ir	160	60
4 Ir	30	10

The ASTAT®-CD Plus allows the user to select motor protection according to IEC Class 10, 20 and NEMA 10, 20 or 30, selectable by "o" -overload- parameter.

Reduced Voltage Starters Solid State

QC2

ASTAT®-CD Plus

Open

Outlines, Dimensions (in. (mm)) and Weights lbs. (kg)
(For Estimating Only)

Open Starters

Product Number	Dimension A	Dimension B	Dimension C	Dimension D	Weight
QC2FDP	7.88 (200)	6.30 (160)	.24 (6)	.89 (22.5)	9.48 (4.3)
QC2GDP	7.88 (200)	6.30 (160)	.24 (6)	.89 (22.5)	9.48 (4.3)
QC2HDP	7.88 (200)	6.30 (160)	.24 (6)	.89 (22.5)	9.48 (4.3)
QC2IDP	9.85 (250)	7.88 (200)	1.22 (31)	1.67 (42.5)	10.14 (4.6)

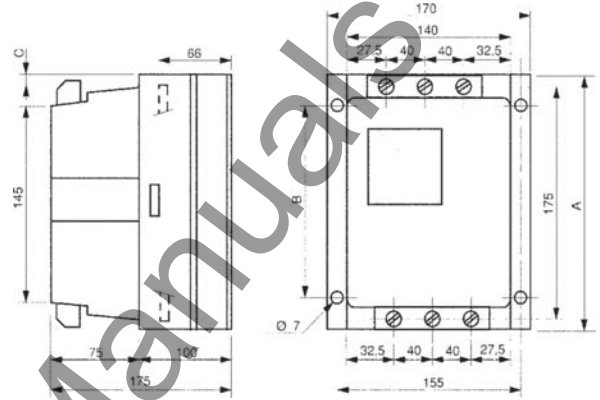

Open Starters

Product Number	Dimension A	Dimension B	Weight
QC2JDP	1.58 (40)	.10 (2.5)	27.56 (12.5)
QC2KDP	1.58 (40)	.10 (2.5)	27.56 (12.5)

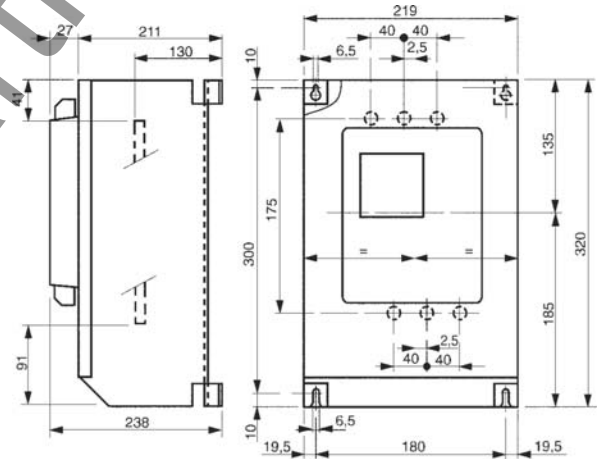

Open Starters

Product Number	Weight
QC2LDP	37.48 (17)
QC2MDP	37.48 (17)

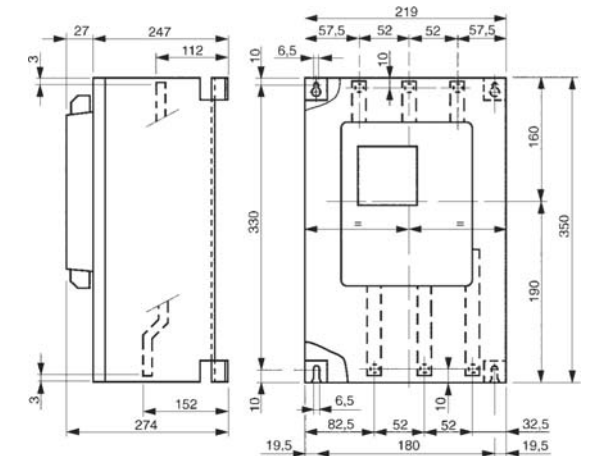

Publications and Reference: See Section 17 for a complete list of additional product-related publications

Reduced Voltage Starters

Section 2

Solid State

QC2

ASTAT®-CD Plus

Open

Outlines, Dimensions (in. mm) and Weights lbs. (kg) (For Estimating Only)

Open Starters

Product Number	Dimension A	Dimension B	Dimension C	Dimension D	Dimension E	Dimension F	Dimension G	Dimension H	Weight
QC2NDP	20.08 (510)	19.30 (490)	12.00 (305)	18.11 (460)	18.31 (465)	.35 (9)	2.09 (53)	4.18 (106)	99.20 (45)
QC2QDP	20.08 (510)	19.30 (490)	12.00 (305)	18.11 (460)	18.31 (465)	.35 (9)	2.09 (53)	4.18 (106)	99.20 (45)
QC2RDP	21.66 (550)	21.26 (540)	12.48 (317)	18.90 (480)	19.49 (495)	.35 (9)	2.33 (59)	4.65 (118)	121.25 (55)
QC2SDP	21.66 (550)	21.26 (540)	12.48 (317)	18.90 (480)	19.49 (495)	.35 (9)	2.33 (59)	4.65 (118)	121.25 (55)
QC2TDP	23.23 (590)	26.97 (685)	12.48 (317)	20.47 (520)	25.20 (640)	.35 (9)	2.32 (59)	4.65 (118)	176 (80)
QC2UDP	31.10 (790)	33.46 (850)	15.83 (402)	27.56 (700)	31.70 (805)	.43 (11)	2.36 (60)	4.72 (120)	231 (105)
QC2VDP	31.10 (790)	33.46 (850)	15.83 (402)	27.56 (700)	31.70 (805)	.43 (11)	2.36 (60)	4.72 (120)	265 (120)
QC2XDP	31.89 (810)	39.37 (1000)	16.02 (407)	28.35 (720)	37.60 (955)	.43 (11)	2.76 (70)	5.51 (140)	330 (150)

Open Starters

Product Number	Dimension J	Dimension K	Dimension L	Dimension M	Dimension N	Dimension O	Weight
QC2NDP	9.45 (240)	1.35 (34)	.50 (12.5)	3.86 (98)	8.43 (214)	2.12 (54)	99.20 (45)
QC2QDP	9.45 (240)	1.35 (34)	.50 (12.5)	3.86 (98)	8.43 (214)	2.12 (54)	99.20 (45)
QC2RDP	9.64 (245)	0.3 (8)	.89 (22.5)	3.47 (88)	8.82 (224)	2.12 (54)	121.25 (55)
QC2SDP	9.64 (245)	0.3 (8)	.89 (22.5)	3.47 (88)	8.82 (224)	2.12 (54)	121.25 (55)
QC2TDP	10.63 (270)	3.94 (100)	.89 (22.5)	3.47 (88)	9.60 (244)	2.54 (64.5)	176 (80)
QC2UDP	13.86 (352)	4.72 (120)	.89 (22.5)	3.74 (95)	13.15 (334)	4.72 (120)	231 (105)
QC2VDP	13.86 (352)	4.72 (120)	.89 (22.5)	3.74 (95)	13.15 (334)	4.72 (120)	265 (120)
QC2XDP	14.05 (357)	4.72 (120)	.89 (22.5)	3.74 (95)	13.54 (344)	4.33 (110)	330 (150)

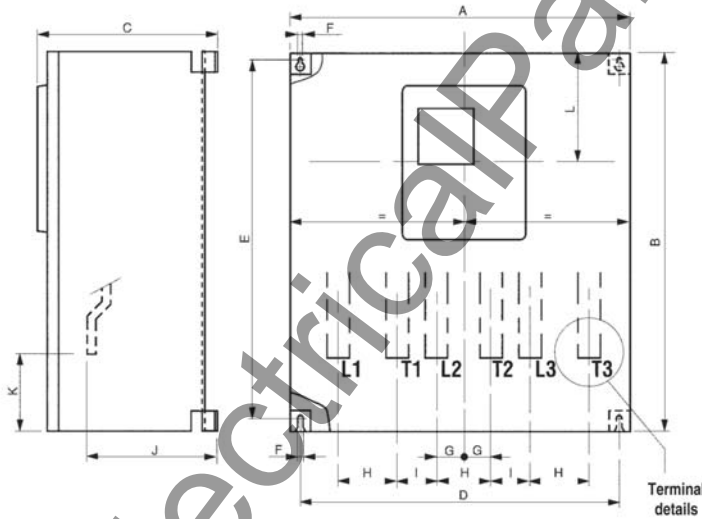

Reduced Voltage Starters Solid State

CR370, CR371, CR373

ASTAT®-CD Plus

Enclosed

Outlines, Dimensions (in. mm) and Weights lbs. (kg) (For Estimating Only)

Section 2

NEMA Type 1

Product Number	Dimension A1	Dimension A2	Dimension B	Dimension C	Weight
CR370FD121	22.6 (574)	-	11.5 (292)	8.9 (226)	45 (20.4)
CR370GD121	22.6 (574)	-	11.5 (292)	8.9 (226)	45 (20.4)
CR370HD121	22.6 (574)	-	11.5 (292)	8.9 (226)	45 (20.4)
CR370ID121 ¹	22.6 (574)	-	11.5 (292)	8.9 (226)	45 (20.4)
CR370JD121	26.6 (676)	-	15.1 (384)	10.9 (277)	91 (41.3)
CR370KD121	26.6 (676)	-	15.1 (384)	10.9 (277)	91 (41.3)
CR370LD121	36.6 (930)	-	18.0 (457)	12.3 (312)	150 (68.0)
CR370MD121	36.6 (930)	-	18.0 (457)	12.3 (312)	150 (68.0)
CR370ND121	43.7 (1110)	48.7 (1237)	31.2 (792)	15.0 (381)	295 (134.0)
CR370QD121	46.3 (1176)	51.3 (1303)	26.3 (668)	15.0 (381)	345 (156.5)
CR370RD121	46.3 (1176)	51.3 (1303)	26.3 (668)	15.0 (381)	375 (170.0)
CR370SD121	46.3 (1176)	51.3 (1303)	26.3 (668)	15.0 (381)	375 (170.0)
CR370TD121 ⁴	78 (1981)	-	44 (1118)	24.5 (622)	900 (409.0)
CR370UD121 ⁴	90 (2286)	-	56 (1423)	26.5 (673)	1300 (590.0)
CR370VD121 ⁴	90 (2286)	-	56 (1423)	26.5 (673)	1400 (636.0)

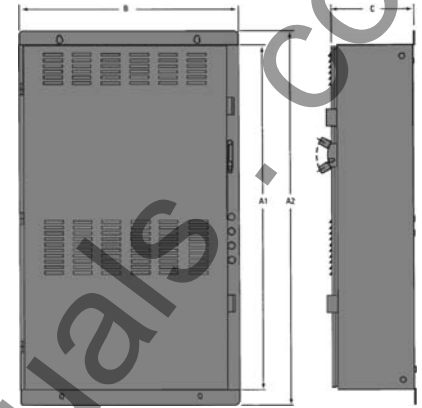

NEMA Type 1

NEMA Type 12/3R

Product Number	Dimension A1	Dimension A2	Dimension B	Dimension C	Weight
CR370FD221	22.6 (574)	25.6 (650)	11.5 (292)	8.9 (226)	58 (26.3)
CR370GD221	22.6 (574)	25.6 (650)	11.5 (292)	8.9 (226)	58 (26.3)
CR370HD221	22.6 (574)	25.6 (650)	11.5 (292)	8.9 (226)	58 (26.3)
CR370ID2212 #	22.6 (574)	25.6 (650)	11.5 (292)	8.9 (226)	58 (26.3)
CR370JD2212#	26.6 (676)	30.0 (762)	15.1 (384)	10.9 (277)	100 (45.4)
CR370KD2212#	26.6 (676)	30.0 (762)	15.1 (384)	10.9 (277)	100 (45.4)
CR370LD2212#	36.6 (930)	40.0 (1016)	18.0 (457)	12.3 (312)	160 (72.6)
CR370MD2212#	36.6 (930)	40.0 (1016)	18.0 (457)	12.3 (312)	160 (72.6)
CR370ND2212# ²	43.7 (1110)	48.7 (1237)	31.2 (792)	15.0 (381)	315 (143.0)
CR370QD2212# ³	46.3 (1176)	51.3 (1303)	26.3 (668)	15.0 (381)	390 (177.0)
CR370RD2212# ³	46.3 (1176)	51.3 (1303)	26.3 (668)	15.0 (381)	450 (204.0)
CR370SD2212# ³	46.3 (1176)	51.3 (1303)	26.3 (668)	15.0 (381)	450 (204.0)
CR370TD2212# ⁴	78 (1981)	-	44 (1118)	24.5 (622)	900 (409.0)
CR370UD2212# ⁴	90 (2286)	-	56 (1423)	26.5 (673)	1300 (590.0)
CR370VD2212# ⁴	90 (2286)	-	56 (1423)	26.5 (673)	1400 (636.0)

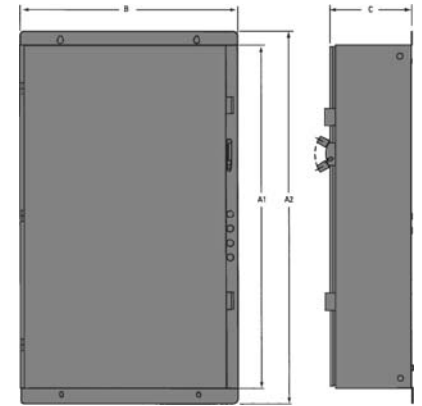

NEMA Type 12/3R

¹Use J or K size enclosure if isolation contactor is included.

²For 2 contactors use combination enclosure on page 2-52.

³Only for ASTAT® without contactors. Use combination enclosure on page 2-52 if contactors are included.

⁴Use bottom outline for enclosure with two doors.

A1 = Box height (excluding flanges)

A2 = Overall height (including flanges)

B = Width

C = Depth

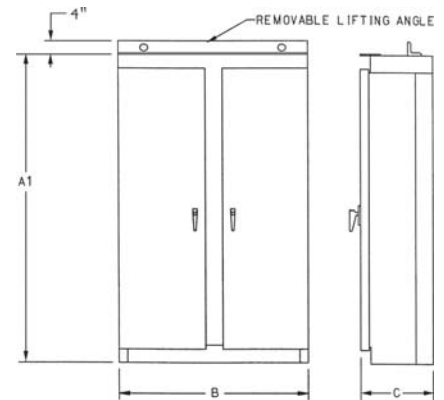

A1 = Box Height (excluding flanges);
A2 = Overall Height (including flanges);
B = Width; C = Depth



Publications and Reference: See Section 17 for a complete list of additional product-related publications

Reduced Voltage Starters Solid State

CR370, CR371, CR373

ASTAT®-CD Plus

Enclosed Combination

Outlines, Dimensions (in./mm) and Weights lbs. (kg) (For Estimating Only)

Section 2

NEMA Type 1

Product Number	Dimension A1	Dimension A2	Dimension B	Dimension C	Weight
CR371FD122B	26.8 (681)	30.0 (762)	20.2 (513)	9.3 (236)	96 (44)
CR371GD122B	26.8 (681)	30.0 (762)	20.2 (513)	9.3 (236)	96 (44)
CR371HD122C	26.8 (681)	30.0 (762)	20.2 (513)	9.3 (236)	96 (44)
CR371ID122C	26.8 (681)	30.0 (762)	20.2 (513)	9.3 (236)	96 (44)
CR371JD122D	38.0 (965)	43.1 (1095)	26.0 (660)	11.6 (295)	173 (78)
CR371KD122D	38.0 (965)	43.1 (1095)	26.0 (660)	11.6 (295)	173 (78)
CR371LD122D	38.3 (973)	43.6 (1107)	31.3 (795)	12.0 (305)	207 (94)
CR371MD122E	38.3 (973)	43.6 (1107)	31.3 (795)	12.0 (305)	207 (94)
CR371ND122E	60.3 (1532)	65.3 (1659)	38.3 (973)	15.0 (381)	440 (200)
CR371QD122F	60.3 (1532)	65.3 (1659)	38.3 (973)	15.0 (381)	440 (200)
CR371RD122G	60.3 (1532)	65.3 (1659)	38.3 (973)	15.0 (381)	485 (220)
CR371SD122G	60.3 (1532)	65.3 (1659)	38.3 (973)	15.0 (381)	500 (227)
CR373TD122L ¹	78 (1981)	-	44 (1118)	24.5 (622)	1000 (454.0)
CR373UD122M ¹	90 (2286)	-	56 (1423)	26.5 (673)	1400 (636.0)
CR373VD122N ¹	90 (2286)	-	56 (1423)	26.5 (673)	1500 (682.0)

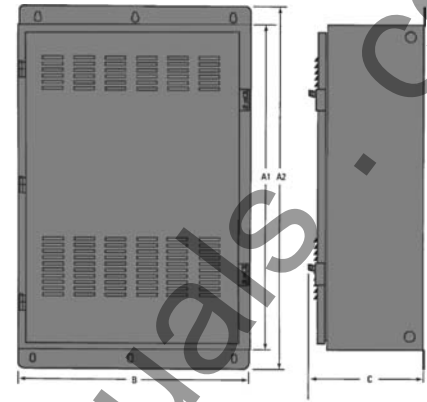

NEMA Type 1

NEMA Type 12/3R

Product Number	Dimension A1	Dimension A2	Dimension B	Dimension C	Weight
CR371FD222B	26.8 (681)	30.0 (762)	20.2 (513)	9.3 (236)	96 (44)
CR371GD222B	26.8 (681)	30.0 (762)	20.2 (513)	9.3 (236)	96 (44)
CR371HD222C	26.8 (681)	30.0 (762)	20.2 (513)	9.3 (236)	96 (44)
CR371ID232C2#	26.8 (681)	30.0 (762)	20.2 (513)	9.3 (236)	96 (44)
CR371JD222D2#	38.0 (965)	43.1 (1095)	26.0 (660)	11.6 (295)	180 (82)
CR371KD222D2#	38.0 (965)	43.1 (1095)	26.0 (660)	11.6 (295)	180 (82)
CR371LD222D2#	38.3 (973)	43.6 (1107)	31.3 (795)	12.0 (305)	220 (100)
CR371MD222E2#	38.3 (973)	43.6 (1107)	31.3 (795)	12.0 (305)	220 (100)
CR371ND222E2#	60.3 (1532)	65.3 (1659)	38.3 (973)	15.0 (381)	480 (218)
CR371QD222F2#	60.3 (1532)	65.3 (1659)	38.3 (973)	15.0 (381)	480 (218)
CR371RD222G2#	60.3 (1532)	65.3 (1659)	38.3 (973)	15.0 (381)	536 (243)
CR371SD222G2#	60.3 (1532)	65.3 (1659)	38.3 (973)	15.0 (381)	550 (250)
CR373TD222L2# ¹	78 (1981)	-	44 (1118)	24.5 (622)	1000 (454.0)
CR373UD222M2# ¹	90 (2286)	-	56 (1423)	26.5 (673)	1400 (636.0)
CR373VD222N2# ¹	90 (2286)	-	56 (1423)	26.5 (673)	1500 (682.0)

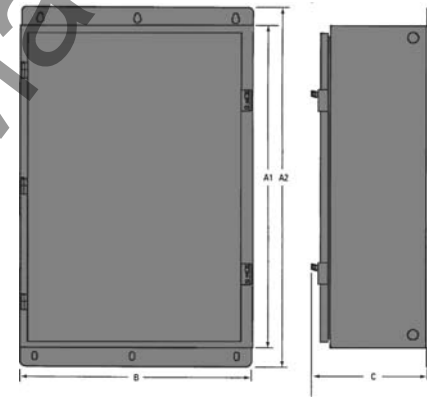

NEMA Type 12/3R

¹Use bottom outline for enclosure with two doors.

- A1 = Box height (excluding flanges)
- A2 = Overall height (including flanges)
- B = width
- C = Depth

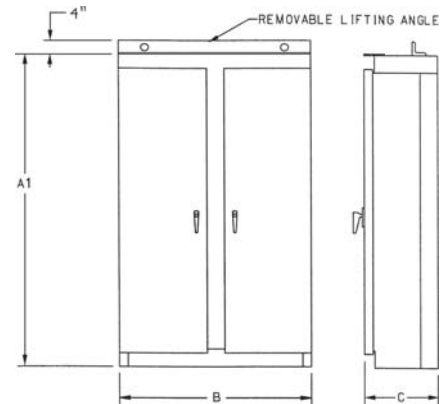

A1 = Box Height (excluding flanges);
A2 = Overall Height (including flanges);
B = Width; C = Depth

Reduced Voltage Starters Electromechanical

CR331, CR332, CR330

Reduced Voltage Starters

GE Fastrac Program Service

Reduced Voltage Starters

Most autotransformer, open transition wye-delta, and part-winding reduced voltage starters are available through GE Fastrac Program.

Standard cycle: 5 weeks

GE Fastrac Program: 3 days

To order GE Fastrac reduced voltage starters, select and price items required that are printed in red. Clearly indicate on the order that Fastrac service is required.

A reduced voltage starter reduces inrush line current and/or starting torque to a polyphase squirrel-cage induction motor. This is done by either reducing voltage applied to the motor during starting or by using only part of the motor windings during starting. GE can supply the three popular types of reduced voltage starters, each designed for specific applications requiring this type starting autotransformer, wye-delta and part-winding starters.



Typical CR331 Starter for Wall Mounting



CR331 Size 6 Starter



CR332 NEMA Size 6
Combination Wye-Delta Motor Starter



Reduced Voltage Starters Electromechanical

CR331

Autotransformer Starters
800 Horsepower Max. @ 230V
1500 Horsepower Max. @ 600V
NEMA Sizes 2-9
Three-Phase
50/60 Hz

Description

These starters in a NEMA Type 1 enclosure consist of a three-leg autotransformer, three contactors (START, RUN, WYE), a pneumatic timer, a three-phase block overload relay, and an autotransformer overtemperature device.

Application

These automatic, closed-transition starters are for use with squirrel-cage motors where reduced starting currents or limited starting torques are required. Overload protection is provided.

Common uses are for blowers, compressors, conveyors, and pump motors.

Standard Features

- Closed Transition:** no interruption in line current during transition
- Three-Leg Autotransformer:** for balanced starting currents and minimum line disturbance. Starting current and torque adjustment easily made by changing autotransformer taps.
- Accurate Adjustment:** pneumatic timing relay permits easy adjustment of starting time on reduced voltage.
- Flexibility:** complete line of factory-installed modifications available.
- High Torque Efficiency:** provides maximum torque per line Ampere.

Starting Characteristics

Voltage Tap % Full Voltage	Starting Torque % Normal	Line Current % Locked Rotor
100%	100%	100%
80%	64%	64%
65%	42%	42%
50%	25%	25%



Typical CR331 Starter for Wall Mounting

Reduced Voltage Starters Electromechanical

CR331

Autotransformer Starters

800 Horsepower Max. @ 230V

1500 Horsepower Max. @ 600V

NEMA Sizes 2-9

Three-Phase

50/60 Hz

Product Number Selection Instructions

NEMA Sizes 2-5

1. Specify starters by complete product number.
Example: CR331EG411 at **\$4314.00, GO-10G1**.
2. Select and specify overload heaters necessary on the basis of motor's full-load current.
3. Order starters not listed or special features by complete description using a listed product number as a reference whenever possible and include motor ratings and horsepower.
Example: Similar to CR331EG411 except with a control transformer and START-STOP push button at total **List Price \$5082.00, GO-10G1**. Starter to control a 50-horsepower, 460-Volt, 60-Hertz motor having a full-load current of 68 Amperes.

NEMA Sizes 6-9

1. Specify: Starter type (CR331) — NEMA Size — Type enclosure — Control circuit voltage — Short-circuit protective device — Line voltage
2. Motor data: Motor type — Horsepower — Voltage — Phase — Number of wires — Frequency — Temperature-rise — Full-load current — Service factor
3. Modifications: (See page 2-66 and 2-67)
4. Ordering Example:
One CR331HB311 NEMA Size 6, nonreversing autotransformer starter in NEMA Type 1 enclosure. For a squirrel-cage induction motor rated 200-horsepower, 230-Volts, three-phase, 60-Hertz, 40°C rise, 500-Amperes full-load current, 3000-Amperes locked-rotor current.
Total **List Price \$24657.00, GO-10G1**.



CR331 Size 6 Starter

Additional Forms

1. Combination Starters

Combination starters with fusible or nonfusible disconnect switch, or circuit breaker are also available. See page 2-67, (Tables 1 and 2) for list price additions.

2. 50-Hertz Starters

50-Hertz starters are available. Contact nearest GE Consumer & Industrial Sales Office for proper selection and pricing of 380 Volt 50 Hertz forms.

3. Special Enclosures

Starters are also available in NEMA Type 3R, 4 and 12 enclosures. See page 2-67 (Table 3) for list price adders.

4. Product Notes

Motor full-load current should not exceed continuous ampere rating of starter.

Reference Publications

Instructions	GEH-4899 (Sizes 2-5)
Instructions	GEH-4863 (Sizes 6-9)



Reduced Voltage Starters Electromechanical

Section 2

CR331

Autotransformer Starters

GE Fastrac Program items are printed in red type.

Three heaters should be ordered as separate items.

Three-Phase NEMA Type 1

NEMA Size	Motor Voltage (60 Hz)	Horsepower	Product Number	List Price GO-10G1
2	200-208	10	CR331DA111	\$3402.00
3	200-208	25	CR331ED111	\$4170.00
4	200-208	40	CR331FF111	\$7758.00
5	200-208	75	CR331GJ111	\$12315.00
6	200-208	150	CR331HA111	\$23805.00
2	230-240	15	CR331DB311	\$3402.00
3	230-240	30	CR331EE311	\$4170.00
4	230-240	50	CR331FG311	\$7758.00
5	230-240	75	CR331GJ311	\$12315.00
5	230-240	100	CR331GK311	\$13281.00
6	230-240	125	CR331HT311	\$22833.00
6	230-240	150	CR331HA311	\$23805.00
6	230-240	200	CR331HB311	\$24657.00
7	230-240	250	CR331JC311	\$37665.00
7	230-240	300	CR331JD311	\$38943.00
8	230-240	400	CR331KF311	\$51519.00
8	230-240	450	CR331KG311	\$54879.00
9	230-240	500	CR331LH311	\$72351.00
9	230-240	600	CR331LJ311	\$74721.00
9	230-240	800	CR331LL311	\$80163.00
2	460-480	15	CR331DB411	\$3402.00
2	460-480	25	CR331DD411	\$3402.00
3	460-480	30	CR331EE411	\$4170.00
3	460-480	50	CR331EG411	\$4314.00
4	460-480	75	CR331FJ411	\$7902.00
4	460-480	100	CR331FK411	\$7902.00
5	460-480	150	CR331GM411	\$12777.00
5	460-480	200	CR331GN411	\$14445.00
6	460-480	250	CR331HC411	\$23997.00
6	460-480	300	CR331HD411	\$25389.00
6	460-480	400	CR331HF411	\$26121.00
7	460-480	500	CR331JH411	\$40773.00
7	460-480	600	CR331JJ411	\$41745.00
8	460-480	700	CR331KK411	\$56535.00
8	460-480	800	CR331KL411	\$58539.00
8	460-480	900	CR331KM411	\$60645.00
9	460-480	1000	CR331LN411	\$81471.00
9	460-480	1250	CR331LP411	\$84327.00
9	460-480	1500	CR331LR411	\$89409.00
2	575-600	15	CR331DB511	\$3402.00
2	575-600	25	CR331DD511	\$3402.00
3	575-600	30	CR331EE511	\$4170.00
3	575-600	50	CR331EG511	\$4314.00
4	575-600	75	CR331FJ511	\$7902.00
4	575-600	100	CR331FK511	\$7902.00
5	575-600	150	CR331GM511	\$12777.00
5	575-600	200	CR331GN511	\$14445.00
6	575-600	250	CR331HC511	\$23997.00
6	575-600	300	CR331HD511	\$25389.00
6	575-600	400	CR331HF511	\$26121.00
7	575-600	500	CR331JH511	\$40773.00
7	575-600	600	CR331JJ511	\$41745.00
8	575-600	700	CR331KK511	\$56535.00
8	575-600	800	CR331KL511	\$58539.00
8	575-600	900	CR331KM511	\$60645.00
9	575-600	1000	CR331LN511	\$81471.00
9	575-600	1250	CR331LP511	\$84327.00
9	575-600	1500	CR331LR511	\$89409.00

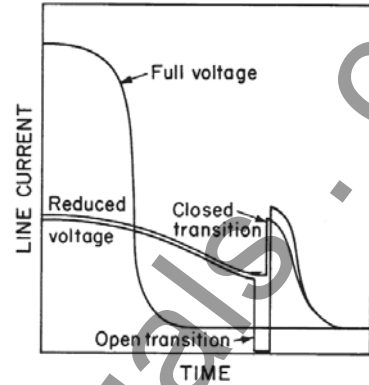

Starting Current Comparison

The above is a comparison of starting current for full-voltage starters, closed transition and open transition autotransformer-type reduced voltage starters. All CR331 starters are the closed transition type.

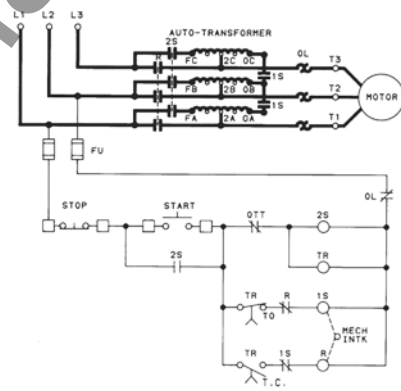

Schematic Diagram - NEMA Size 4

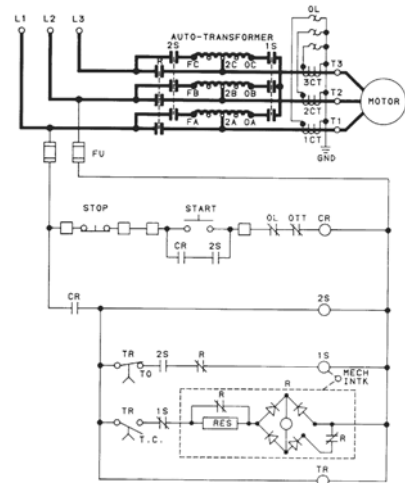

Schematic Diagram - NEMA Size 7

Diagram Legend

- Terminal Board
- 1S—Wye Contactor
- 2S—Start Contactor
- AT—Autotransformer
- CR—Control Relay
- CT—Current Transformer
- FU—Fuse
- OL—Thermal Overload Relay (Motor)
- OTT—Over Temperature Thermostat
- R—Run Contactor
- TC—Time Closing Contact
- TO—Time Opening Contact
- TR—Pneumatic Timer

Product Number Selection Instructions: See page 2-55

Reduced Voltage Starters Electromechanical

CR331

Autotransformer Starters

Outlines, Dimensions (in. and mm) and Weights lbs. (For Estimating Only)

CR331 NEMA Type 1 Sizes 2-4

Product Number	Dimension A	Dimension B	Dimension C	Dimension D	Dimension E	Dimension F	Weight
CR331D	43.00 (1092.2)	26.00 (660.4)	10.75 (273.0)	40.50 (1028.7)	22.00 (558.8)	38.00 (965.2)	250
CR331E	53.00 (1346.2)	36.00 (914.4)	10.75 (273.0)	50.50 (1282.7)	32.00 (812.8)	48.00 (1219.2)	450
CR331F	53.00 (1346.2)	36.00 (914.4)	10.75 (273.0)	50.50 (1282.7)	32.00 (812.8)	48.00 (1219.2)	450

CR331 NEMA Type 1 Size 6

NEMA Size	Non-Combination/Combination	Motor Voltage	Height	Width	Depth	Weight
6	Non-combination	All ratings	90.0 (2286)	44.0 (1118)	20.0 (508)	1500
6	Combination w/ circuit breakers	All ratings	90.0 (2286)	44.0 (1118)	20.0 (508)	1500
6	Combination /all others	200/208	90.0 (2286)	44.0 (1118)	20.0 (508)	1600
6	Combination /all others	230	90.0 (2286)	44.0 (1118)	20.0 (508)	1600
6	Combination /all others	460	90.0 (2286)	44.0 (1118)	20.0 (508)	1600
6	Combination /all others	575	90.0 (2286)	44.0 (1118)	20.0 (508)	1400/1600

CR331 NEMA Type 1 Sizes 7-9

NEMA Size	Non-Combination/Combination	Motor Voltage	Height	Width	Depth	Weight
7	Non-combination	All ratings	90.0 (2286)	44.0 (1118)	20.0 (508)	1500
7	Combination w/ circuit breakers	All ratings	90.0 (2286)	44.0 (1118)	20.0 (508)	1700
7	Combination /All others	All ratings	90.0 (2286)	44.0 (1118)	20.0 (508)	1900
8	Non-combination	All ratings	90.0 (2286)	88.0 (2235)	40.0 (1016)	2400
8	Combination	All ratings	90.0 (2286)	88.0 (2235)	40.0 (1016)	2800
9	Non-combination	All ratings	90.0 (2286)	88.0 (2235)	40.0 (1016)	2600
9	Combination	All ratings	90.0 (2286)	88.0 (2235)	40.0 (1016)	3000

CR331 NEMA Type 1 Size 5

See Diagram For Dimensions

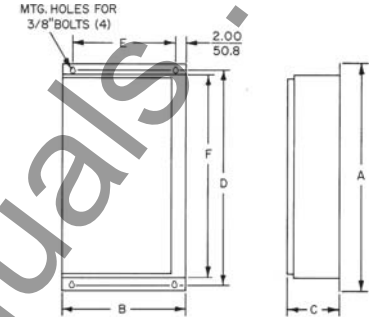

CR331, NEMA Type 1, Size 2-4

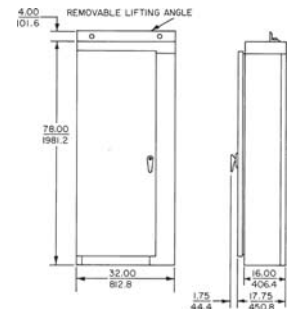

CR331G, NEMA Type 1, Size 5, 750 lbs.



Publications and Reference: See Section 17 for a complete list of additional product-related publications

Reduced Voltage Starters Electromechanical

Section 2

CR332

Wye-Delta Starters

800 Horsepower Max. @ 230V

1500 Horsepower Max. @ 600V

NEMA Sizes 1YD-8YD

Three-Phase

50/60 Hz

Description

The wye-delta (open transition) starter consists of the following components in a Type 1 enclosure: three contactors, one block overload relay (for three-phase protection), and one pneumatic time delay relay. The wye-delta (closed transition) starter consists of the following components in a Type 1 enclosure: same as in the open transition plus one transition contactor and required number of transition resistors.

Application

The wye-delta magnetic motor starters are for use with low starting torque applications such as fans, compressors, and conveyors driven by six lead wye-delta motors capable of being connected in wye and in delta. Wye-delta starting provides a low inrush current which results in low starting torque. When the motor windings are connected in wye, starting torque is approximately 1/3 of normal. Reconnecting to delta on run applies full voltage to each winding.

Closed transition forms are characterized by the addition of resistors during transition from start to run. This eliminates opening the circuit and prevents transient currents which might occur and cause objectionable light flicker.

Features

- Variety of Enclosures:** complete line of enclosures for every purpose.
- Easy to Wire:** ample wiring is front connected.
- Accurate Adjustment:** pneumatic time-delay relay permits accurate adjustment of starting time on wye connection.
- Motor Protection:** provided by overload relays and holding interlocks.
- Flexibility:** complete line of factory-installed modifications available.
- Reduce High Transient Currents:** closed transition forms eliminate opening the circuit during transition, thereby reducing light flicker and high transient currents.

Product Number Selection Instructions

NEMA Sizes 1YD-5YD

1. Order starter by complete product number.
Example: CR332EG314 at **\$4917.00, GO-10G1**.
2. Select and specify three overload heaters on basis of motor's full-load current.
3. Order forms not listed or special features by complete description using a listed product number as a reference wherever possible and include full-load motor ratings and horsepower.
Example: Similar to CR332DF414 except to have a control transformer and START-STOP push button installed at total **List Price \$4365.00, GO-10G1**.



CR332 NEMA Size 6
Combination Wye-Delta Motor Starter

NEMA Sizes 6YD-8YD

1. Specify: Starter type (CR332) — NEMA Size — Line voltage — Type enclosure — Control circuit voltage — Short-circuit protective device — Open- or closed-circuit transition
2. Motor data: Motor type — Horsepower — Voltage — Phase — Number of wires — Frequency — Temperature-rise — Full-load current — Service factor — Delta-connected locked-rotor current
3. Modifications: (See page 2-67)
4. Ordering Example:
One CR332HA311 NEMA Size 6 wye-delta open-transition starter in NEMA Type 1 enclosure. For squirrel-cage induction motor 200-horsepower, 230-Volt, three-phase, 60-Hertz, 40°C rise, 500-Ampere full-load current, 3000-Ampere locked-rotor current.

Additional Forms

1. **Combination Forms**
Combination forms with fusible or nonfusible disconnect switch are available. Circuit breaker forms of closed transition starters only are also available. Refer to page 2-67 for list price additions.
2. **50-Hertz Forms**
50-Hertz starters are available. Contact nearest GE Consumer & Industrial Sales Office for proper selection and pricing of 380 Volt 50 Hertz forms.
3. **Special Enclosures**
Wye-delta starters are also available in NEMA Type 3R, 4 and 12 enclosures. Order by description using listed product number as reference. See page 2-66 (non-combination) or 2-67 (combination) for list price adders.
4. **Product Notes**
Full-load current should not exceed continuous ampere rating of starter.

Reference Publications

Instructions: NEMA Size 1YD-5YD

Open transition	GEH-5076
Closed transition	GEH-5077

Reduced Voltage Starters Electromechanical

CR332 Open Circuit Transition

Wye-Delta Starters

GE Fastrac Program items are printed in red type.
Three heaters should be ordered as separate items.

Three-Phase NEMA Type 1 Open Circuit Transition

NEMA Size	Motor Voltage (60 Hz)	Horsepower	Product Number	List Price GO-10G1
1YD	200-208	10	CR332CA111	\$2061.00
2YD	200-208	15	CR332DB111	\$2439.00
2YD	200-208	20	CR332DC111	\$2439.00
3YD	200-208	25	CR332ED111	\$3549.00
3YD	200-208	30	CR332EE111	\$3549.00
3YD	200-208	40	CR332EF111	\$3549.00
4YD	200-208	50	CR332FG111	\$7401.00
4YD	200-208	60	CR332FH111	\$7401.00
5YD	200-208	75	CR332GJ111	\$13305.00
5YD	200-208	100	CR332GK111	\$13305.00
5YD	200-208	125	CR332GL111	\$13305.00
5YD	200-208	150	CR332GM111	\$13305.00
6YD	200-208	200	CR332HA111	\$28473.00
6YD	200-208	250	CR332HB111	\$28473.00
6YD	200-208	300	CR332HC111	\$28473.00
7YD	200-208	350	CR332JD111	\$38403.00
7YD	200-208	400	CR332JE111	\$38403.00
7YD	200-208	450	CR332JF111	\$38403.00
7YD	200-208	500	CR332JG111	\$38403.00
8YD	200-208	600	CR332KH111	\$53145.00
8YD	200-208	700	CR332KJ111	\$53145.00
8YD	200-208	750	CR332KK111	\$53145.00
1YD	230-240	10	CR332CA311	\$2061.00
2YD	230-240	15	CR332DB311	\$2439.00
2YD	230-240	20	CR332DC311	\$2439.00
2YD	230-240	25	CR332DD311	\$2439.00
3YD	230-240	30	CR332EE311	\$3549.00
3YD	230-240	40	CR332EF311	\$3549.00
3YD	230-240	50	CR332EG311	\$3549.00
4YD	230-240	60	CR332FH311	\$7401.00
4YD	230-240	75	CR332FJ311	\$7401.00
5YD	230-240	100	CR332GK311	\$13305.00
5YD	230-240	125	CR332GL311	\$13305.00
5YD	230-240	150	CR332GM311	\$13305.00
6YD	230-240	200	CR332HA311	\$28473.00
6YD	230-240	250	CR332HB311	\$28473.00
6YD	230-240	300	CR332HC311	\$28473.00
6YD	230-240	350	CR332HD311	\$28473.00
7YD	230-240	400	CR332JE311	\$38403.00
7YD	230-240	450	CR332JF311	\$38403.00
7YD	230-240	500	CR332JG311	\$38403.00
8YD	230-240	600	CR332KH311	\$53145.00
8YD	230-240	700	CR332KJ311	\$53145.00
8YD	230-240	750	CR332KK311	\$53145.00
8YD	230-240	800	CR332KL311	\$53145.00

Three-Phase NEMA Type 1 Open Circuit Transition

NEMA Size	Motor Voltage (60 Hz)	Horsepower	Product Number	List Price GO-10G1
1YD	460-480	15	CR332CB411	\$2061.00
2YD	460-480	20	CR332DC411	\$2439.00
2YD	460-480	25	CR332DD411	\$2439.00
2YD	460-480	30	CR332DE411	\$2439.00
2YD	460-480	40	CR332DF411	\$2439.00
3YD	460-480	50	CR332EG411	\$3549.00
3YD	460-480	60	CR332EH411	\$3549.00
3YD	460-480	75	CR332EJ411	\$3549.00
4YD	460-480	100	CR332EG411	\$7401.00
4YD	460-480	125	CR332FL411	\$7401.00
4YD	460-480	150	CR332FM411	\$7401.00
5YD	460-480	200	CR332GN411	\$13305.00
5YD	460-480	250	CR332GP411	\$13305.00
5YD	460-480	300	CR332GR411	\$13305.00
6YD	460-480	350	CR332HG411	\$28473.00
6YD	460-480	400	CR332HE411	\$28473.00
6YD	460-480	450	CR332HF411	\$28473.00
6YD	460-480	500	CR332HG411	\$28473.00
6YD	460-480	600	CR332HH411	\$28473.00
6YD	460-480	700	CR332HJ411	\$28473.00
7YD	460-480	750	CR332JK411	\$38403.00
7YD	460-480	800	CR332JL411	\$38403.00
7YD	460-480	900	CR332JM411	\$38403.00
7YD	460-480	1000	CR332JN411	\$38403.00
8YD	460-480	1250	CR332KP411	\$53145.00
8YD	460-480	1500	CR332KR411	\$53145.00
1YD	575-600	15	CR332CB511	\$2061.00
2YD	575-600	20	CR332DC511	\$2439.00
2YD	575-600	25	CR332DD511	\$2439.00
2YD	575-600	30	CR332DE511	\$2439.00
2YD	575-600	40	CR332DF511	\$2439.00
3YD	575-600	50	CR332EG511	\$3549.00
3YD	575-600	60	CR332EH511	\$3549.00
3YD	575-600	75	CR332EJ511	\$3549.00
4YD	575-600	100	CR332FG511	\$7401.00
4YD	575-600	125	CR332FL511	\$7401.00
4YD	575-600	150	CR332FM511	\$7401.00
5YD	575-600	200	CR332GN511	\$13305.00
5YD	575-600	250	CR332GP511	\$13305.00
5YD	575-600	300	CR332GR511	\$13305.00
6YD	575-600	350	CR332HS511	\$28473.00
6YD	575-600	400	CR332HE511	\$28473.00
6YD	575-600	450	CR332HF511	\$28473.00
6YD	575-600	500	CR332HG511	\$28473.00
6YD	575-600	600	CR332HH511	\$28473.00
6YD	575-600	700	CR332HJ511	\$28473.00
7YD	575-600	750	CR332JK511	\$38403.00
7YD	575-600	800	CR332JL511	\$38403.00
7YD	575-600	900	CR332JM511	\$38403.00
7YD	575-600	1000	CR332JN511	\$38403.00
8YD	575-600	1250	CR332KP511	\$53145.00
8YD	575-600	1500	CR332KR511	\$53145.00



Publications and Reference: See Section 17 for a complete list of additional product-related publications

Factory Installed Modifications: See page 2-67
Heater Selection Table: See page 2-69

Reduced Voltage Starters Electromechanical

Section 2

CR332 Closed Circuit Transition

Wye-Delta Starters

Three heaters should be ordered as separate items.

Three-Phase NEMA Type 1 Closed Circuit Transition

NEMA Size	Motor Voltage (60 Hz)	Horsepower	Product Number	List Price GO-10G1
1YD	200-208	10	CR332CA114	\$3147.00
2YD	200-208	15	CR332DB114	\$3525.00
2YD	200-208	20	CR332DC114	\$3561.00
3YD	200-208	25	CR332ED114	\$4785.00
3YD	200-208	30	CR332EE114	\$4785.00
3YD	200-208	40	CR332EF114	\$4917.00
4YD	200-208	50	CR332FG114	\$9399.00
4YD	200-208	60	CR332FH114	\$9399.00
5YD	200-208	75	CR332GJ114	\$16161.00
5YD	200-208	100	CR332GK114	\$16161.00
5YD	200-208	125	CR332GL114	\$16305.00
5YD	200-208	150	CR332GM114	\$16305.00
6YD	200-208	200	CR332HA114	\$32787.00
6YD	200-208	250	CR332HB114	\$32787.00
6YD	200-208	300	CR332HC114	\$32787.00
7YD	200-208	350	CR332JD114	\$49797.00
7YD	200-208	400	CR332JE114	\$49797.00
7YD	200-208	450	CR332JF114	\$49797.00
7YD	200-208	500	CR332JG114	\$49797.00
8YD	200-208	600	CR332KH114	\$68127.00
8YD	200-208	700	CR332KJ114	\$68127.00
8YD	200-208	750	CR332KK114	\$68127.00
1YD	230-240	10	CR332CA314	\$3147.00
2YD	230-240	15	CR332DB314	\$3525.00
2YD	230-240	20	CR332DC314	\$3561.00
2YD	230-240	25	CR332DD314	\$3561.00
3YD	230-240	30	CR332EE314	\$4785.00
3YD	230-240	40	CR332EF314	\$4917.00
3YD	230-240	50	CR332EG314	\$4917.00
4YD	230-240	60	CR332FH314	\$9399.00
4YD	230-240	75	CR332FJ314	\$9687.00
5YD	230-240	100	CR332GK314	\$16161.00
5YD	230-240	125	CR332GL314	\$16305.00
5YD	230-240	150	CR332GM314	\$16305.00
6YD	230-240	200	CR332HA314	\$32787.00
6YD	230-240	250	CR332HB314	\$32787.00
6YD	230-240	300	CR332HC314	\$32787.00
6YD	230-240	350	CR332HD314	\$32787.00
7YD	230-240	400	CR332JE314	\$49797.00
7YD	230-240	450	CR332JF314	\$49797.00
7YD	230-240	500	CR332JG314	\$49797.00
8YD	230-240	600	CR332KH314	\$68127.00
8YD	230-240	700	CR332KJ314	\$68127.00
8YD	230-240	750	CR332KK314	\$68127.00
8YD	230-240	800	CR332KL314	\$68127.00

Three-Phase NEMA Type 1 Closed Circuit Transition

NEMA Size	Motor Voltage (60 Hz)	Horsepower	Product Number	List Price GO-10G1
1YD	460-480	15	CR332CB414	\$3147.00
2YD	460-480	20	CR332DC414	\$3561.00
2YD	460-480	25	CR332DD414	\$3561.00
2YD	460-480	30	CR332DE414	\$3561.00
2YD	460-480	40	CR332DF414	\$3693.00
3YD	460-480	50	CR332EG414	\$4917.00
3YD	460-480	60	CR332EH414	\$5001.00
3YD	460-480	75	CR332EJ414	\$5559.00
4YD	460-480	100	CR332FK414	\$10071.00
4YD	460-480	125	CR332FL414	\$10215.00
4YD	460-480	150	CR332FM414	\$10215.00
5YD	460-480	200	CR332GN414	\$16701.00
5YD	460-480	250	CR332GP414	\$16701.00
5YD	460-480	300	CR332GR414	\$17607.00
6YD	460-480	350	CR332HD414	\$32787.00
6YD	460-480	400	CR332HE414	\$32787.00
6YD	460-480	450	CR332HF414	\$32787.00
6YD	460-480	500	CR332HG414	\$32787.00
6YD	460-480	600	CR332HH414	\$32787.00
6YD	460-480	700	CR332HJ414	\$32787.00
7YD	460-480	750	CR332JK414	\$49797.00
7YD	460-480	800	CR332JL414	\$49797.00
7YD	460-480	900	CR332JM414	\$49797.00
7YD	460-480	1000	CR332JN414	\$49797.00
8YD	460-480	1250	CR332KP414	\$68127.00
8YD	460-480	1500	CR332KR414	\$68127.00
1YD	575-600	15	CR332CB514	\$3147.00
2YD	575-600	20	CR332DC514	\$3561.00
2YD	575-600	25	CR332DD514	\$3561.00
2YD	575-600	30	CR332DE514	\$3561.00
2YD	575-600	40	CR332DF514	\$3693.00
3YD	575-600	50	CR332EG514	\$4917.00
3YD	575-600	60	CR332EH514	\$5001.00
3YD	575-600	75	CR332EJ514	\$5559.00
4YD	575-600	100	CR332FK514	\$10071.00
4YD	575-600	125	CR332FL514	\$10215.00
4YD	575-600	150	CR332FM514	\$10215.00
5YD	575-600	200	CR332GN514	\$16701.00
5YD	575-600	250	CR332GP514	\$16701.00
5YD	575-600	300	CR332GR514	\$17607.00
6YD	575-600	350	CR332HD514	\$32787.00
6YD	575-600	400	CR332HE514	\$32787.00
6YD	575-600	450	CR332HF514	\$32787.00
6YD	575-600	500	CR332HG514	\$32787.00
6YD	575-600	600	CR332HH514	\$32787.00
6YD	575-600	700	CR332HJ514	\$32787.00
7YD	575-600	750	CR332JK514	\$49797.00
7YD	575-600	800	CR332JL514	\$49797.00
7YD	575-600	900	CR332JM514	\$49797.00
7YD	575-600	1000	CR332JN514	\$49797.00
8YD	575-600	1250	CR332KP514	\$68127.00
8YD	575-600	1500	CR332KR514	\$68127.00

Heater Selection Table: See page 2-69
 Product Number Selection Instructions: See page 2-58
 Factory Installed Modifications: See page 2-67

Reduced Voltage Starters Electromechanical

CR332

Wye-Delta Starters

Outlines, Dimensions (in. ^{in.} / mm) and Weights lbs. (For Estimating Only)

CR332 NEMA Type 1 Sizes 1YD-4YD Open Circuit Transition

Product Number	Dimension A	Dimension B	Dimension C	Dimension D	Dimension E	Dimension F	Weight
CR332C	35.00 (889.0)	24.00 (609.6)	8.25 (209.5)	32.50 (825.5)	20.00 (508.0)	30.00 (762.0)	150
CR332D	35.00 (889.0)	24.00 (609.6)	8.25 (209.5)	32.50 (825.5)	20.00 (508.0)	30.00 (762.0)	150
CR332E	53.00 (1346.2)	30.00 (762.0)	10.75 (273.0)	50.50 (1282.7)	26.00 (660.4)	48.00 (1219.2)	250
CR332F	53.00 (1346.2)	30.00 (762.0)	10.75 (273.0)	50.50 (1282.7)	26.00 (660.4)	48.00 (1219.2)	250

CR332 NEMA Type 1 Sizes 1YD-4YD Closed Circuit Transition

Product Number	Dimension A	Dimension B	Dimension C	Dimension D	Dimension E	Dimension F	Weight
CR332C	35.00 (889.0)	24.00 (609.6)	8.25 (209.5)	32.50 (825.5)	20.00 (508.0)	30.00 (762.0)	175
CR332D	43.00 (1092.2)	26.00 (660.4)	10.75 (273.0)	40.50 (1028.7)	22.00 (558.8)	38.00 (965.2)	200
CR332E	53.00 (1346.2)	30.00 (762.0)	10.75 (273.0)	50.50 (1282.7)	26.00 (660.4)	48.00 (1219.2)	300
CR332F	53.00 (1346.2)	30.00 (762.0)	10.75 (273.0)	50.50 (1282.7)	26.00 (660.4)	48.00 (1219.2)	300

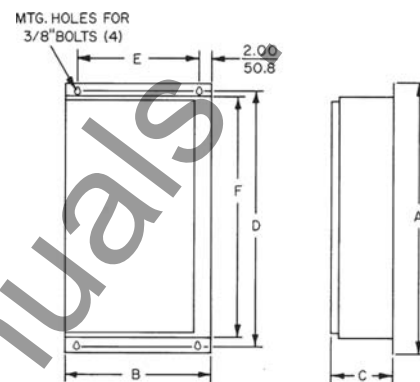

NEMA Type 1, Sizes 1YD-4YD

CR332 NEMA Type 1 Size 5YD

See Diagram For Dimensions

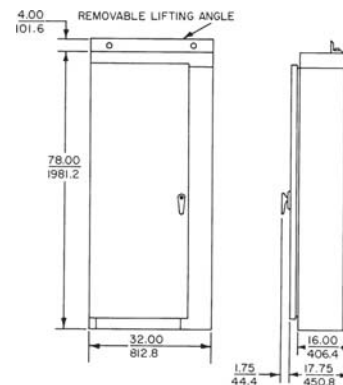

NEMA Size 5YD Floor-Mounted Enclosure, Open or Closed Transition; 650lbs.

CR332 NEMA Type 1 Sizes 6YD-8YD

NEMA Size	Non-combination/Combo	Height	Width	Depth	Weight
6YD	Non-combination	90.0 (2286)	56.0 (1422)	20.0 (508)	1800
7YD	Non-combination	90.0 (2286)	56.0 (1422)	20.0 (508)	2600
8YD ¹	Non-combination	Contact your GE Consumer & Industrial Representative.			
6YD	Combination	90.0 (2286)	56.0 (1422)	20.0 (508)	2100
7YD	Combination	90.0 (2286)	56.0 (1422)	20.0 (508)	2800
8YD ¹	Combination	Contact your GE Consumer & Industrial Representative			

¹Circuit breaker should not be used with open transition forms because the transient currents associated with the open transition may cause nuisance tripping of the circuit breaker.



Publications and Reference: See Section 17 for a complete list of additional product-related publications

Reduced Voltage Starters Electromechanical

CR332

Wye-Delta Starters
Schematic Diagrams

Section 2

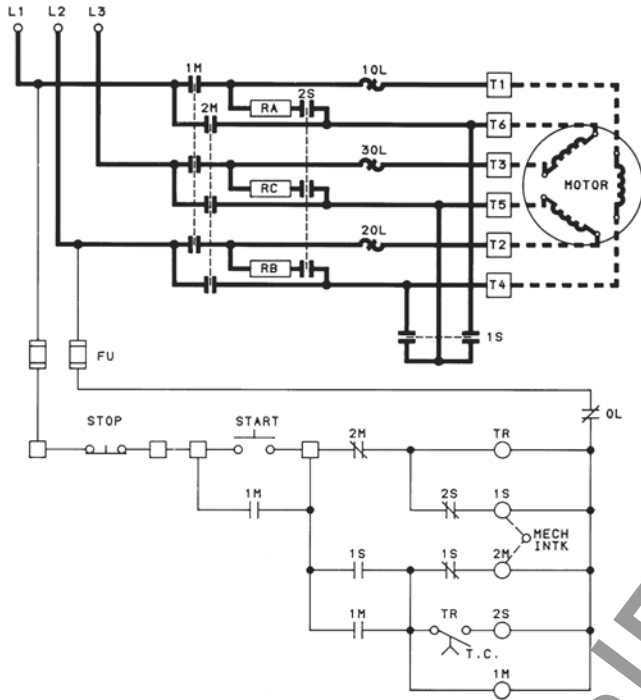

Typical Schematic Diagram for Closed Transition
Wye-Delta Starter (NEMA Size 4YD)

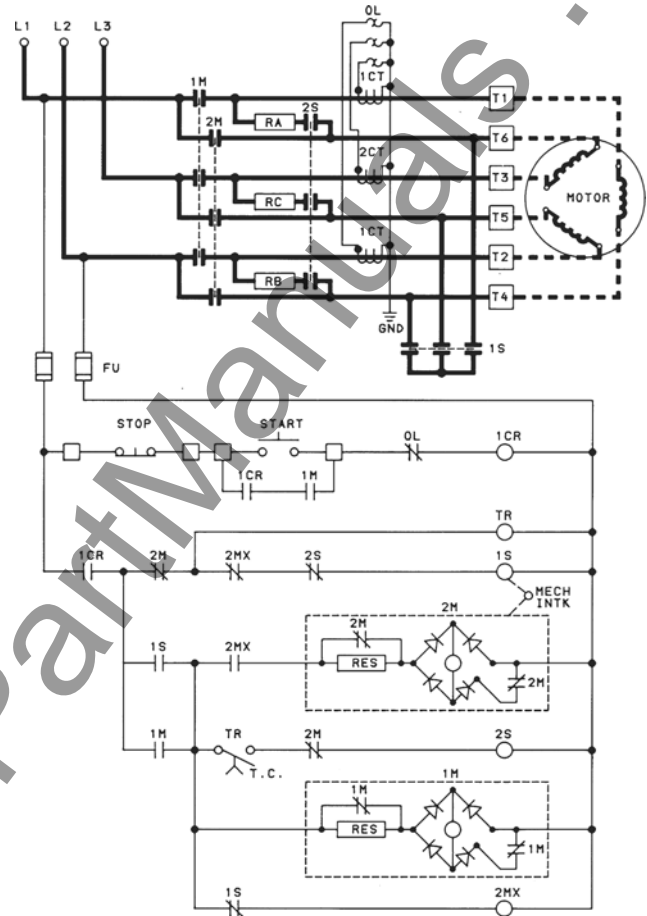

Typical Schematic Diagram for Closed Transition
Wye-Delta Starter (NEMA Size 7YD)

Diagram Legend

- 1M, 2M - Line Contactors
- 1S, 2S - Start Contactors
- RA, RB, RC - Transition Resistors
- OL - Thermal Overload Relay
- TR - Pneumatic Timing Relay
- 2MX - 2M Auxiliary Relay
- 1CR - Control Relay
- TR - Timing Relay
- FU - Fuse
- TC - Time Closing
- CT - Current Transformer
- RES - Resistor
- - Terminal Board Point

Reduced Voltage Starters Electromechanical

CR330

Part-Winding Starters

700 Horsepower Max. @ 230V

1400 Horsepower Max. @ 600V

NEMA Sizes 1PW-8PW

Three-Phase

50/60 Hz

Description

A part-winding starter consists of two, three-pole magnetic contactors, each selected for one-half the current rating of the motor; a pneumatic timing head; and two bimetallic three-phase block overload relays.

Application

Used where the power company specifies limitations on increments of current inrush. Frequent installations are in commercial buildings driving air conditioning compressors, pumps, fans and blowers. This method of starting is normally less expensive than most other forms of reduced inrush starting, but has its limitations on the type of load that can be accelerated on the first point. Inrush current is limited to approximately 65 percent of normal. Overload protection is provided.

These starters may be applied to any standard dual voltage 230/460 Volt induction motor that is to be used on 230 Volt systems. For motors with part-winding starting on 460 Volts or higher, contact nearest GE Consumer & Industrial Sales Office.

Features

- Simple Construction:** two contactors, a timing relay and two overload relays.
- Small Size:** starters are smaller than others in the reduced voltage category with comparable rating.
- Closed Transition:** inherently provided.
- Accurate Adjustment:** pneumatic time-delay contact permits accurate adjustment of maximum motor speeds on starting connections.
- Flexibility:** complete line of factory-installed modifications available.

Product Number Selection Instructions

NEMA Sizes 1PW-5PW

1. Specify starter by complete product number.
Example: CR330DF411 at **\$1872.00, GO-10G1.**
2. Select and specify overload heaters necessary, as a separate item, on basis of motor's full-load current (six heaters required).
3. Order starters not listed or special features by complete description using a listed product number as reference wherever possible and include motor rating and horsepower.
Example: Similar to CR330DF411 except with a HAND-OFF-AUTO selector switch and a red indicating light in the flange, at total **List Price, \$2352.00, GO-10G1.** Starter to control a 40-hp, 460-Volt, 60-Hertz motor having a full-load current of 57 Amperes.

NEMA Sizes 6PW-9PW

1. Starter type (CR330): — Line voltage — Short-circuit protective device — Control circuit voltage — NEMA Size — Type enclosure.
2. Motor data: Motor type — Horsepower — Voltage — Phase — Number of wires — Frequency — Temperature-rise — Full-load current — Service factor.
3. Modifications: (See page 2-66)
4. Ordering Example:
One CR330J NEMA Size 7 part-winding, nonreversing starter in NEMA Type 1 enclosure. For part winding induction motor rated 400 horsepower, 230 Volts, three-phase, 60 Hertz, 40°C rise, 1000 Amperes full-load current, 6000 Amperes locked-rotor current. Starter enclosure to have HAND-OFF-AUTO selector switch and START push button installed on flange area at **\$450.00** addition. Total **List Price \$35730.00, GO-10G1.**

Additional Forms

1. Combination forms with fusible or nonfusible disconnect switch, or circuit breakers, are available. Part winding starters are also available as open forms; or in NEMA Type 3R, 4 and 12 enclosures. Order by description, using listed form as reference. See page 2-67 for list price adders.
2. **50 Hertz Starters**
50 Hertz starters are available. Contact your nearest GE Consumer & Industrial sales office for proper selection and pricing of 380 V, 50 Hz forms.
3. **Product Notes**
Two-pole vertical motors, 50 Hp and larger require special starters. Contact your nearest GE Consumer & Industrial sales office for information. Hp ratings are based on locked rotor currents corresponding to 65% of full winding values.

Reference Publications

Instructions

GEH 4897

(Sizes 1-5)



Publications and Reference: See Section 17 for a complete list of additional product-related publications

Reduced Voltage Starters Electromechanical

Section 2

CR330

Part Winding Starters

List price does not include HOA selector switch or START push button. Six heaters should be ordered as separate items.

Three-Phase NEMA Type 1

NEMA Size	Motor Voltage (60 Hz)	Horsepower ¹	Product Number	List Price GO-10G1
1 PW	200-208	10	CR330CA111	\$1314.00
2 PW	200-208	20	CR330DC111	\$1872.00
3 PW	200-208	40	CR330EF111	\$2640.00
4 PW	200-208	75	CR330FJ111	\$5646.00
5 PW	200-208	150	CR330GM111	\$11826.00
1 PW	230-240	10	CR330CA311	\$1314.00
2 PW	230-240	25	CR330DD311	\$1872.00
3 PW	230-240	50	CR330EG311	\$2640.00
4 PW	230-240	75	CR330FJ311	\$5646.00
5 PW	230-240	150	CR330GM311	\$11826.00
6 PW	230-240	300	CR330HC311	\$24624.00
7 PW	230-240	450	CR330JF311	\$35280.00
8 PW	230-240	700	CR330KJ311 ²	\$47238.00
1 PW	460-480	15	CR330CB411	\$1314.00
2 PW	460-480	40	CR330DF411	\$1872.00
3 PW	460-480	75	CR330EJ411	\$2640.00
4 PW	460-480	150	CR330FM411	\$5646.00
5 PW	460-480	350	CR330GT411	\$11826.00
6 PW	460-480	600	CR330HH411	\$24624.00
7 PW	460-480	900	CR330JL411	\$35280.00
8 PW	460-480	1400	CR330KN411 ²	\$47238.00
1 PW	575-600	15	CR330CB511	\$1314.00
2 PW	575-600	40	CR330DF511	\$1872.00
3 PW	575-600	75	CR330EJ511	\$2640.00
4 PW	575-600	150	CR330FM511	\$5646.00
5 PW	575-600	350	CR330GT511	\$11826.00
6 PW	575-600	600	CR330HH511	\$24624.00
7 PW	575-600	900	CR330JL511	\$35280.00
8 PW	575-600	1400	CR330KN511 ²	\$47238.00

¹Hp ratings are based on locked rotor currents corresponding to 65% of full winding values.

²Size 8PW starters are back-connected and require rear access.

Part-Winding Starters Outlines, Dimensions (mm) and Weights lbs. (For Estimating Only)

CR330 NEMA Type 1 Sizes 1-5

Product Number	Dimension A	Dimension B	Dimension C	Dimension D	Dimension E	Dimension F	Weight
CR330C	35.00 (889.0)	24.00 (609.6)	8.25 (209.5)	32.50 (825.5)	20.00 (508.0)	30.00 (762.0)	150
CR330D	35.00 (889.0)	24.00 (609.6)	8.25 (209.5)	32.50 (825.5)	20.00 (508.0)	30.00 (762.0)	150
CR330E	53.00 (1346.2)	26.00 (660.4)	10.75 (273.0)	50.50 (1282.7)	22.00 (558.8)	48.00 (1219.2)	250
CR330F	53.00 (1346.2)	26.00 (660.4)	10.75 (273.0)	50.50 (1282.7)	22.00 (558.8)	48.00 (1219.2)	250
CR330G	53.00 (1346.2)	36.00 (914.4)	10.75 (273.0)	50.50 (1282.7)	32.00 (812.8)	48.00 (1219.2)	350

CR330 NEMA Type 1 Sizes 6-8

NEMA Size	Non-combination/Combo	Height	Width	Depth	Weight
6 PW	Non-combination	90.0 (2286)	44.0 (1118)	20.0 (508)	1500
7 PW	Non-combination	90.0 (2286)	44.0 (1118)	20.0 (508)	1600
8 PW ¹	Non-combination	Contact your GE Consumer & Industrial Representative			
6 PW	Combination	90.0 (2286)	44.0 (1118)	20.0 (508)	2000
7 PW	Combination	90.0 (2286)	44.0 (1118)	20.0 (508)	2100
8 PW ¹	Combination	Contact your GE Consumer & Industrial Representative.			

¹Size 8PW starters are back-connected and require rear access.

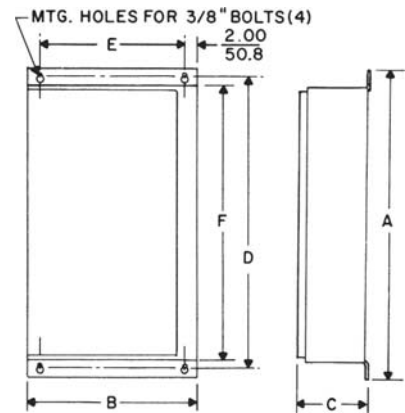

CR330, NEMA Type 1, Sizes 1-5

Product Number Selection Instructions: See page 2-63

Reduced Voltage Starters Electromechanical

CR330

Part-Winding Starters Schematic Diagrams

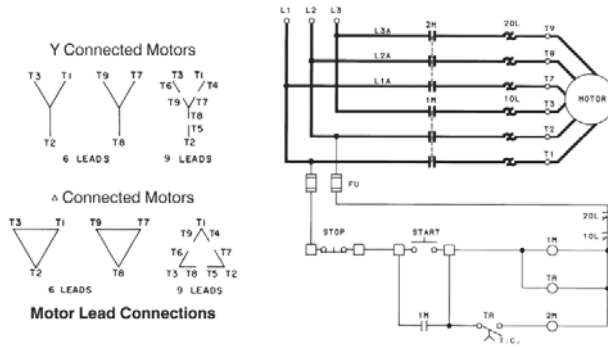

Connect motor terminals to controller terminals having the same marking (for example T1 to T1). Since not all 9-lead motors are suitable for part winding applications, contact motor manufacturer for complete 9-lead data.

Typical Schematic Diagram
(NEMA Size 4 PW)

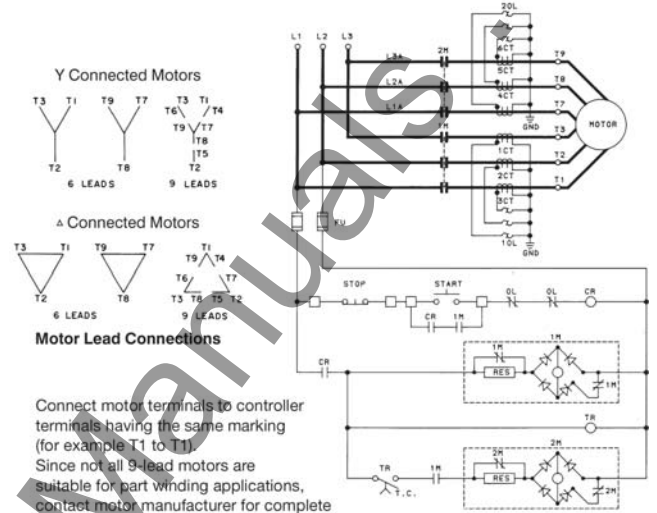

Connect motor terminals to controller terminals having the same marking (for example T1 to T1). Since not all 9-lead motors are suitable for part winding applications, contact motor manufacturer for complete 9-lead data.

Typical Schematic Diagram
(NEMA Size 7 PW)

Diagram Legend

- 1M - Accelerating Contactor
- 2M - Run Contactor
- TR - Pneumatic Timing Relay
- OL - Thermal Overload Relay
- CR - Control Relay
- CT - Current Transformer
- FU - Fuse
- RES - Resistor
- TC - Time Closing
- TR - Timing Relay
- - Terminal Board Point



Reduced Voltage Starters Electromechanical CR330, CR331, CR332 Factory Installed Modifications

Order should read "Similar to (list basic device product number), except with . . ."

Description	List Price Addition, GO-10G1 (Apply to List Price of Complete Device)								
	Control Product Line Covered			NEMA Size					
	CR330 (Partwinding)	CR331 (Autotransformers)	CR332 (Wye-Delta)	1, 1YD or 1PW	2, 2YD or 2PW	3, 3YD or 3PW	4, 4YD or 4PW	5, 5YD or 5PW	6-9, 6-8YD or 6-8PW
1. Devices mounted in cover or flange of enclosure.									
a) START-STOP push button (provides undervoltage protection, or	X	X	X	\$300.00	\$300.00	\$300.00	\$300.00	\$300.00	\$300.00
b) HAND-OFF-AUTO selector switch, or	X	X	X	\$300.00	\$300.00	\$300.00	\$300.00	\$300.00	\$300.00
c) HAND-OFF-AUTO selector switch and START push button (provides undervoltage protection), or	X	X	X	\$450.00	\$450.00	\$450.00	\$450.00	\$450.00	\$450.00
d) Red indicating light unit (for any of the above)	X	X	X	\$180.00	\$180.00	\$180.00	\$180.00	\$180.00	\$180.00
2. Auxiliary contact unit 1 normally open or 1 normally closed each	X	X	X	\$66.00	\$192.00	\$192.00	\$192.00	\$192.00	\$198.00
3. Control circuit transformer with control relay (with primary and secondary fusing)	X	X	X	\$288.00	\$372.00	\$468.00	\$528.00	\$588.00	\$588.00
4. Enclosures (noncombination) forms									
a) NEMA Type 4	—	X	X(C.T.) ¹	\$1860.00	\$1860.00	\$1860.00	\$3420.00	\$3420.00	\$4500.00
b) NEMA Type 3R or Type 12	—	X	X(C.T.) ¹	\$900.00	\$1080.00	\$1140.00	\$1440.00	\$1620.00	\$2250.00
c) NEMA Type 4	X	—	X(O.T.) ²	\$720.00	\$810.00	\$1170.00	\$1842.00	\$3420.00	\$4500.00
d) NEMA Type 3R or Type 12	X	—	X(O.T.) ²	\$600.00	\$750.00	\$900.00	\$1200.00	\$1620.00	\$2250.00
5. Enclosure omission	X	X	X	—	(-)\$144.00	(-)\$372.00	(-)\$660.00	(-)\$1332.00	—
6. Separate control (115 VAC)	X	X	X	NC	NC	NC	NC	NC ³	NC ³
7. AC Ammeter (single-phase, includes one C.T.)	X	X	X	\$1188.00	\$1188.00	\$1188.00	\$1188.00	\$1188.00	\$1188.00
8. AC Ammeter and transfer switch (3-phase, no C.T.'s)	X	X	X	\$1800.00	\$1800.00	\$1800.00	\$1800.00	\$1800.00	\$1800.00
9. AC Voltmeter (single-phase)	X	X	X	\$1188.00	\$1188.00	\$1188.00	\$1188.00	\$1188.00	\$1188.00
10. AC Voltmeter and transfer switch (3-phase)	X	X	X	\$1800.00	\$1800.00	\$1800.00	\$1800.00	\$1800.00	\$1800.00
11. Elapsed time meter	X	X	X	\$348.00	\$348.00	\$348.00	\$348.00	\$348.00	\$348.00
12. Current transformers									
800 Amperes maximum, each	X	X	X	\$312.00	\$312.00	\$312.00	\$312.00	\$312.00	\$840.00
4000 Amperes maximum, each	X	X	X	—	—	—	—	—	\$2130.00
13. Fused control circuit—two fuses	X	X	X	\$132.00	\$132.00	NC	NC	NC	NC
14. Overload relay with 1NO-1NC contacts	X	X	X	\$24.00	\$24.00	\$24.00	\$24.00	\$24.00	\$24.00
15. Ambient compensated overload protection	X	X	X	\$27.00 ⁴	\$27.00 ⁴	\$27.00 ⁴	\$27.00 ⁴	\$27.00 ⁴	\$27.00 ⁴
16. Incomplete sequence protection	X	X	X	\$714.00	\$714.00	\$714.00	\$714.00	\$714.00	\$714.00
17. Running phase-reversal and phase-failure protection	X	X	X	\$1056.00	\$1056.00	\$1056.00	\$1056.00	\$1056.00	\$1056.00
18. Space heater—per starter (control not included)	X	X	X	\$420.00	\$420.00	\$420.00	\$420.00	\$420.00	\$420.00
19. Thermostat for control of space heaters	X	X	X	\$420.00	\$420.00	\$420.00	\$420.00	\$420.00	\$420.00

¹Closed transition.

²Open transition.

³Supplied as a control relay, for low control circuit power consumption.

⁴Add \$54.00, GO-10G1 for part winding starters.

Product Number Selection Instructions:
See page 2-55 (Autotransformers), page 2-58, 2-59 (Wye Delta), page 2-63 (Part Winding)

Reduced Voltage Starters Electromechanical CR330, CR331, CR332 Factory Installed Modifications

Table No. 1—Combination Reduced Voltage Starters (In Type 1 Enclosure)

Disconnect switch or circuit breaker type short-circuit protection can be supplied at the following additions to the basic starter price.

NEMA Size	CR330 (PW) ¹			NEMA Size	CR332 (YD) ¹			Nonfusible Disconnect	Fusible Disconnect ²	Circuit Breaker ³
	200-208 V	Maximum Horsepower 230-240 V	460-575 V		208-240 V	Maximum Horsepower 230-240 V	460-575 V	List Price Addition, GO-10G1	List Price Addition, GO-10G1	List Price Addition, GO-10G1
1PW	10	10	15	1YD	10	10	15	\$720.00	See Table No. 2 below	\$1032.00
2PW	20	25	40	2YD	20	25	40	\$912.00	See Table No. 2 below	\$1122.00
3PW	40	50	75	3YD	40	50	75	\$1260.00	See Table No. 2 below	\$2052.00
4PW	75	75	150	4YD	60	75	150	\$2256.00	See Table No. 2 below	\$3990.00
5PW	150	150	350	5YD	150	150	300	\$5178.00	See Table No. 2 below	\$5874.00
6PW	—	200	400	6YD	—	200	400	\$5178.00	\$8490.00	\$5874.00
—	—	250	500	—	—	250	500	\$5478.00	\$11224.00	\$5874.00
—	—	300	600	—	—	300	600	\$5478.00	\$11224.00	\$8142.00
—	—	—	—	—	—	350	700	\$5478.00	\$15864.00	\$8142.00
7WP	—	400	—	7YD	—	400	—	\$12720.00	\$15864.00	\$13800.00
—	—	450	—	—	—	450	—	\$12720.00	\$18546.00	\$13800.00
—	—	—	—	—	—	500	—	\$12720.00	\$40626.00	\$13800.00
—	—	—	800	—	—	—	800	\$12720.00	\$15864.00	\$13800.00
—	—	—	900	—	—	—	1000	\$12720.00	\$18546.00	\$13800.00
8PW	—	—	—	8YD	—	—	—	\$12720.00	\$40626.00	\$13800.00
—	—	700	—	—	—	800	—	\$48324.00	\$55254.00	\$27444.00
—	—	—	1000	—	—	—	—	\$12720.00	\$18546.00	\$13800.00
—	—	—	1400	—	—	—	1500	\$48324.00	\$55272.00	\$27444.00

NEMA Size	CR331 ¹			Nonfusible Disconnect	Fusible Disconnect ²	Circuit Breaker
	200-208V	Maximum Horsepower 230-240V	460-575V	List Price Addition, GO-10G1	List Price Addition, GO-10G1	List Price Addition, GO-10G1
2	10	15	25	\$720.00	See Table No. 2 below	\$1032.00
3	25	30	50	\$912.00	See Table No. 2 below	\$1122.00
4	40	50	100	\$1260.00	See Table No. 2 below	\$2052.00
5	75	100	200	\$2256.00	See Table No. 2 below	\$3990.00
6	150	200	400	\$5178.00	\$8490.00	\$5874.00
7	—	300	600	\$5478.00	\$11224.00	\$8142.00
8	—	400	—	\$12720.00	\$15864.00	\$13800.00
—	—	450	—	\$12720.00	\$18546.00	\$13800.00
—	—	—	800	\$12720.00	\$15864.00	\$13800.00
—	—	—	900	\$12720.00	\$18546.00	\$13800.00
9	—	500	—	\$12720.00	\$40626.00	\$13800.00
—	—	800	—	\$48324.00	\$55254.00	\$27444.00
—	—	—	1000	\$12720.00	\$18546.00	\$13800.00
—	—	—	1500	\$48324.00	\$55272.00	\$27444.00

¹For 50 Hertz applications, contact nearest GE Consumer & Industrial Sales Office.

²Price additions include current-limiting fuses.

³Not available for YD open transition.

Table No. 2—Combination Reduced Voltage Starters (In Type 1 Enclosure)

Fusible Disconnect, NEMA Sizes 1-5, 1PW-5PW, 1YD-5YD

A fusible disconnect can be supplied on starters at the following additions to the basic noncombination price. When ordering, please specify the required fuse clip rating. Price additions shown do not include fuses.

Product Number and NEMA Size	List Price Additions, GO-10G1—Fusible Disconnect				
	Fuse Clip Size—Amperes				
	30 or 60	100	200	400	600
CR330					
1PW	1YD	2	\$768.00	\$894.00	—
2PW	2YD	3	\$984.00	\$984.00	\$1224.00
3PW	3YD	4	—	\$1524.00	\$1524.00
4PW	4YD	5	—	—	\$2472.00
5PW	5YD	—	—	—	—

Table No. 3—Combination Reduced Voltage Starters (In Type 3R, Type 4, and Type 12 Enclosures) Use with Tables No. 1 & No. 2

Type Of Enclosure	Base Product Number	List Price Additions, GO-10G1						
		Starter Size—Additions to NEMA Type 1 Price						
		1, 1YD, 1PW	2, 2YD, 2PW	3, 3YD, 3PW	4, 4YD, 4PW	5, 5YD, 5PW	6-8, 6-8YD, 6-8PW	9, 9YD, 9PW
3R or 12	CR330, 332 (O.T.)	\$648.00	\$834.00	\$1068.00	\$1440.00	\$2070.00	\$2250.00	—
	CR331, 332 (C.T.)	\$912.00	\$1128.00	\$1224.00	\$1608.00	\$1860.00	\$2250.00	\$2250.00
4	CR330, 332 (O.T.)	\$1176.00	\$1266.00	\$2154.00	\$2826.00	\$5220.00	\$4500.00	—
	CR331, 332 (C.T.)	\$2316.00	\$2316.00	\$2316.00	\$4404.00	\$4404.00	\$4500.00	\$4500.00

¹For 50 Hertz applications, contact nearest GE Consumer & Industrial Sales Office.

²Price additions include current-limiting fuses.

³Not available for YD open transition.

Publications and Reference: See Section 17 for a complete list of additional product-related publications



Reduced Voltage Starters Electromechanical CR123, CR123F Heaters

How to Select Heaters

Listed values are for continuous rated motors with 1.15 service factor. For continuous rated motors with 1.0 service factor, multiply full-load current of motor by 0.9 and use this value to select heater.

1. Find device table (Example: CR330E)
2. Determine maximum motor full-load Amperes of your device. Then find heater product number (Example: CR330E, if maximum amperes is 56.9 then heater product number will be CR123F327B)

Note: If full-load Amperes of motor falls between increments in table, use next higher rating.

Ordering Information

All CR123C and CR123F heaters are packaged three to a carton. Items of these heaters, ordered for either customer's stock or any other purpose, are to be specified in multiples of three (such as 3, 6, 9, 12, 15, etc.). Minimum order quantity is three.

Pricing Information

All heaters, product numbers CR123C and CR123F are **List Price \$9.00 each, GO-10H**. Packaged in quantities of three; must be ordered in multiples of three.

Part Winding (6 heaters required)

CR330C, Size 1PW		CR330D, Size 2PW		CR330E, Size 3PW		CR330F, Size 4PW		CR330G, Size 5PW	
Max. Motor Full-Load Amperes	Heater Product Number	Max. Motor Full-Load Amperes	Heater Product Number	Max. Motor Full-Load Amperes	Heater Product Number	Max. Motor Full-Load Amperes	Heater Product Number	Max. Motor Full-Load Amperes	Heater Product Number
11.0	CR123C592A	27.2	CR123C151B	54.0	CR123F300B	96.8	CR123F567B	230	CR123C592A
11.8	CR123C630A	33.4	CR123C163B	58.2	CR123F327B	111.2	CR123F614B	250	CR123C630A
12.9	CR123C695A	35.8	CR123C180B	63.6	CR123F357B	114.8	CR123F658B	270	CR123C695A
14.4	CR123C778A	37.8	CR123C198B	67.9	CR123F395B	120.1	CR123F719B	302	CR123C778A
16.4	CR123C867A	40.8	CR123C214B	72.9	CR123F430B	138.9	CR123F772B	328	CR123C867A
17.4	CR123C955A	45.4	CR123C228B	86.4	CR123F487B	143.4	CR123F848B	358	CR123C955A
19.3	CR123C104B	49.4	CR123C250B	92.5	CR123F567B	159.9	CR123F914B	390	CR123C104B
20.1	CR123C113B	52.6	CR123C273B	107.4	CR123F614B	184.7	CR123F104C	430	CR123C113B
22.0	CR123C125B	59.0	CR123C303B	111.6	CR123F658B	193.8	CR123F114C	462	CR123C125B
24.8	CR123C137B	65.0	CR123C330B	119.3	CR123F719B	210.0	CR123F118C	510	CR123C137B
26.4	CR123C151B	73.3	CR123C366B	136.2	CR123F772B	226.0	CR123F133C	--	--
30.8	CR123C163B	77.9	CR123C400B	143.0	CR123F848B	248.0	CR123F149C	--	--
34.2	CR123C180B	--	--	--	--	--	--	--	--
36.2	CR123C198B	--	--	--	--	--	--	--	--
40.0	CR123C214B	--	--	--	--	--	--	--	--
43.0	CR123C228B	--	--	--	--	--	--	--	--
45.0	CR123C250B	--	--	--	--	--	--	--	--

Autotransformers (3 heaters required)

CR331D, Size 2		CR331E, Size 3		CR331F, Size 4		CR331G, Size 5	
Max. Motor Full-Load Amperes	Heater Product Number	Max. Motor Full-Load Amperes	Heater Product Number	Max. Motor Full-Load Amperes	Heater Product Number	Max. Motor Full-Load Amperes	Heater Product Number
7.15	CR123C867A	25.1	CR123F300B	33.9	CR123F430B	125	CR123C630A
7.58	CR123C955A	27.0	CR123F327B	40.1	CR123F487B	135	CR123C695A
8.39	CR123C104B	30.5	CR123F357B	43.1	CR123F567B	151	CR123C778A
9.11	CR123C113B	31.5	CR123F395B	48.4	CR123F614B	164	CR123C867A
9.67	CR123C125B	33.9	CR123F430B	54.0	CR123F658B	179	CR123C955A
11.0	CR123C137B	40.1	CR123F487B	57.0	CR123F719B	195	CR123C104B
12.0	CR123C151B	43.1	CR123F567B	64.5	CR123F772B	215	CR123C113B
14.4	CR123C163B	48.4	CR123F614B	68.6	CR123F848B	231	CR123C125B
16.3	CR123C180B	54.0	CR123F658B	73.3	CR123F914B	255	CR123C137B
17.3	CR123C198B	57.0	CR123F719B	83.6	CR123F104C	270	CR123C151B
19.3	CR123C214B	64.5	CR123F772B	93.0	CR123F114C	--	--
20.9	CR123C228B	68.6	CR123F848B	106.0	CR123F118C	--	--
22.9	CR123C250B	73.3	CR123F914B	123.0	CR123F133C	--	--
24.7	CR123C273B	83.6	CR123F104C	131.0	CR123F149C	--	--
28.0	CR123C303B	90.0	CR123F114C	135.0	CR123F161C	--	--
31.1	CR123C330B	--	--	--	--	--	--
35.9	CR123C366B	--	--	--	--	--	--
41.5	CR123C400B	--	--	--	--	--	--
43.4	CR123C440B	--	--	--	--	--	--
45.0	CR123C460B	--	--	--	--	--	--

Reduced Voltage Starters
Electromechanical
CR123, CR123F
Heaters

Wye-Delta (3 heaters required)

CR332C, Size 1YD		CR332D, Size 2YD		CR332E, Size 3YD		CR332F, Size 4YD		CR332G, Size 5YD	
Max. Motor Full-Load Amperes	Heater Product Number	Max. Motor Full-Load Amperes	Heater Product Number	Max. Motor Full-Load Amperes	Heater Product Number	Max. Motor Full-Load Amperes	Heater Product Number	Max. Motor Full-Load Amperes	Heater Product Number
12.4	CR123C867A	20.8	CR123C151B	43.5	CR123F300B	72.3	CR123F430B	216	CR123C630A
13.1	CR123C955A	24.9	CR123C163B	45.4	CR123F327B	83.8	CR123F487B	234	CR123C695A
14.5	CR123C104B	28.2	CR123C180B	52.8	CR123F357B	90.7	CR123F567B	262	CR123C778A
15.8	CR123C113B	30.0	CR123C198B	54.6	CR123F395B	95.7	CR123F614B	284	CR123C867A
16.8	CR123C125B	32.4	CR123C214B	58.6	CR123F430B	111.7	CR123F658B	310	CR123C955A
19.1	CR123C137B	35.1	CR123C228B	67.3	CR123F487B	122.5	CR123F719B	338	CR123C104B
20.6	CR123C151B	38.5	CR123C250B	72.3	CR123F567B	135.1	CR123F772B	372	CR123C113B
24.8	CR123C163B	42.8	CR123C273B	83.8	CR123F614B	154.0	CR123F848B	400	CR123C125B
27.9	CR123C180B	47.0	CR123C303B	90.7	CR123F658B	166.1	CR123F914B	442	CR123C137B
29.8	CR123C198B	55.6	CR123C330B	95.7	CR123F719B	188.8	CR123F104C	467	CR123C151B
32.3	CR123C214B	62.2	CR123C366B	111.7	CR123F772B	213.0	CR123F114C	—	—
34.6	CR123C228B	69.7	CR123C400B	122.5	CR123F848B	226.9	CR123F118C	—	—
36.7	CR123C250B	72.9	CR123C440B	135.1	CR123F914B	239.0	CR123F133C	—	—
40.5	CR123C273B	77.9	CR123C460B	154.0	CR123F104C	—	—	—	—
43.8	CR123C303B	—	—	156.0	CR123F114C	—	—	—	—
46.8	CR123C330B	—	—	—	—	—	—	—	—



Publications and Reference: See Section 17 for a complete list of additional product-related publications

