

KEY INTERLOCK

GENERAL INFORMATION

DIMENSIONS

IMPORTANT

Make absolutely sure applicable equipment is de-energized and properly grounded before proceeding with any installation or maintenance.

➔ GOULD-BROWN BOVERI

SPECIAL INFORMATION

KEY CONTROL

IMPORTANT—To insure correct operation of the Kirk interlock system it is necessary to remove all loosely or removably held keys before operating the equipment on which the interlocks are mounted.

An interlock arrangement drawing or sketch is usually supplied for the more elaborate systems. These drawings clearly indicate all keys which should be held in the interlocks during the normal operation of the equipment on which the interlocks are mounted. As stated before, all other interlock keys should be removed.

The keys removed from the Kirk interlocks should be returned to the I-T-E Circuit Breaker Company, Greensburg, or retained by authorized personnel for use as spare keys.

The spare keys must not be normally available to operating personnel, since the use of these keys, where not specifically required, will result in incorrect operation of the equipment on which the interlocks are mounted. Any spare keys should be given to operating personnel only, if and when the corresponding operating key has been destroyed.

ADDITIONAL KEYS will be provided **ONLY** with proper authorization from the ultimate user to which the specific key combination has been assigned.

SERVICE AND MAINTENANCE

Under normal operating conditions the Kirk interlocks should not require any maintenance service. However, if service should be required, this should only be done by the I-T-E Circuit Breaker Company, Greensburg, Pa. All service will be performed on an emergency basis.

Any defective interlock or key should be returned to the factory in Greensburg, Pa. If this is impossible, the following information should be forwarded to I-T-E, in addition to the specific trouble experienced.

1. RE lock number—obtain from the face of the lock cylinder.
2. G.O. or S.O. number—obtain from nameplate on the interlock.
3. Item number—obtain from nameplate on interlock.
4. Specific equipment and manufacturer's name on which interlock is applied.

OPERATION

All Kirk interlocks lock the equipment on which they are applied through some kind of an adapter mechanism. The adapter mechanism is a part of the equipment. It is not a part of the Kirk interlock.

If, when operating the interlock, it should not work freely, the interlock should be removed and operated by itself. If the unmounted Kirk interlock operates satisfactorily, the interlock has no doubt been incorrectly mounted on the equipment, or possibly the adapter mechanism is defective in some way.

The interlock should then be remounted and positioned on the adapter so that it operates satisfactorily and the lock bolt will freely align or mate with the adapter.

Should the interlock still not operate satisfactorily when remounted on the adapter it is possible that the adapter mechanism is defective. If so, the adapter should be corrected, either on the job, or by the supplier, and/or manufacturer of the equipment on which the interlock is mounted.

THE KIRK KEY INTERLOCK SYSTEM

INTRODUCTION

A Kirk Key Interlock System contains two basic elements. One element is the simple, rugged locks which do the physical work. The other element is the intangible items. These include the careful engineering which goes into system planning, and the complete records of locks and keys.

The locks themselves are all heavy-duty six-pin tumbler models. All the interlock housings are of heavy bronze or brass, and locking bolts are $\frac{5}{8}$ " diameter Everdur rod. These locks come in many different housings and with special adapters and special attachments. (Dimensions and descriptions of locks are found on pages 5-14.)

Kirk interlock units operate on the principle that the key can be removed only when the locking bolt is in a predetermined position. This principle is illustrated in the simple diagram in Figure 4. Here a Kirk Interlock is mounted on a device consisting

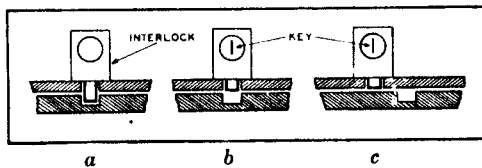

FIG. 4

of two moving parts. The locking bolt extends through both parts, mechanically preventing any movement (Fig. 4a). In Fig. 4b, the key has been inserted in the lock and turned to withdraw the bolt. Now the device is capable of movement. Fig. 4c indicates that it has been operated. The key cannot now be removed from the lock, because it is impossible to extend the bolt.

This simple interlock principle can be extended to very complex interlock schemes. In complex schemes, a key must be obtained from one lock before another lock can be operated. In this way, it is possible to guarantee a given sequence of operation for diverse equipment even though it may be spread out over considerable area.

When two or more key interlock units are used in a scheme, an interlock "system" is formed. Fig. 5 illustrates two interlock units applied to two devices to form a simple Kirk Interlock System.

Here the problem is to permit either device A or device B to be closed, but not permit them to be closed at the same time. In Fig. 5, A is closed, and B is locked open. A is operative and can be opened. B is not operative because it is locked. To close

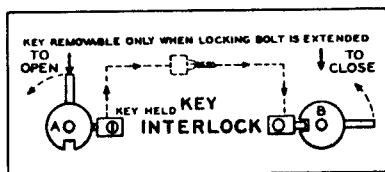

FIG. 5

B, the key from A must be obtained. The lock on A is so arranged that its key may be withdrawn only when the device is locked open. After A has been locked open, the key is removed and can be used to unlock B, permitting B to be closed. The key is then retained in the lock on B as long as B is closed.

An illustration of a Kirk Interlock System in a chemical application is shown in Fig. 6. The problem here is to permit

ADVANTAGES OF A KIRK INTERLOCK SYSTEM

1. Interlocks over any distance, without complicated and expensive connecting rods or other mechanisms.
2. Applicable to any standard equipment. No need to design equipment to fit the interlock.
3. Very difficult to defeat. However, can be arranged to be defeated in an emergency.
4. Is easily expanded or re-arranged. Can also be added to existing interlock systems, mechanical, electrical, or key type.
5. Units can be mounted directly on the device, or on an adapter.
6. Accurate records kept by I-T-E prevent duplication of combinations and other errors.

either of two valves A or B to be open, but not to permit both to be open at the same time.

V is a vat for liquid. A is the inlet valve. B is the outlet sewer valve to a sewer, used when the vat is being flushed during cleaning. Proper interlocking prevents liquid from flowing into the vat while the sewer valve is open. Ordinarily, Valve B is locked closed. It can be opened only when Valve A has been locked closed, thus freeing the key to be taken to B.

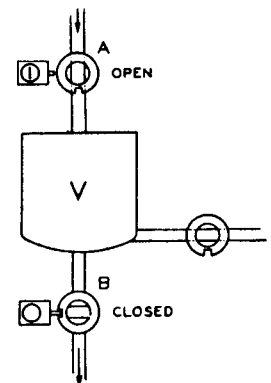

FIG. 6

LOCK CONSTRUCTION

The locks used in Kirk Interlock Systems are special 6-pin tumbler locks. A typical lock is shown in Fig. 7. The lock cylinder is $1\frac{23}{64}$ " diameter and it extends $1\frac{1}{16}$ " beyond the interlock body. The key has an ample finger grip with a distinctive square pattern.

A lock number is stamped on the face of the lock and also on the key. It is a serial number applying to the lock combination, and is recorded at I-T-E. Careful filing and analysis of these combination numbers by I-T-E engineers is essential to avoid confusion between different systems, and to aid in possible future replacement or extension. These records are maintained as a service for the ultimate user of the interlocks, to guarantee that no improper interlock locks will be included in the user's installation. I-T-E puts great emphasis on keeping exact records of the final use of all locks.

Each lock is capable of operation by only one key. An exception to this is a master lock (also called an apartment lock). Such a lock may be operated by each of two or more keys, which are not themselves interchangeable.

Exposed view of a standard interlock, showing workings of locking bolt. When correct key is inserted in lock cylinder, it can be rotated. This rotational motion, transmitted through the bolt operating cam, causes the locking bolt to move.

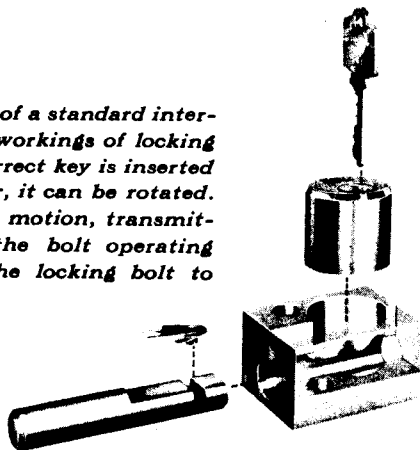

FIG. 7

Master keys, which will operate all the locks in a system, are not recommended. If an emergency occurs calling for an unusual operation, a master key might be used in the wrong interlock and cause trouble. It is recommended instead that standard non-master-keyed interlocks and keys be used in place of master-keyed interlocks.

Master keys cannot be used in standard locks. When master keys are required, all the locks of the master key series become special and are priced accordingly.

MULTI-LOCK ARRANGEMENTS

The single lock unit is described by type letters such as B, F, or D, depending on its use and its mounting arrangement. In many cases, two or more of these locks may be mounted in the same housing, and they are then designated as multi-lock interlocks.

For example, if two type B locks are mounted in the same housing, the unit is called an "M2B",—M being derived from "multi" and "2" indicating the number of locks.

In a standard 2-lock assembly, two keys, one from each of two other locks, must be inserted in the multiple lock before the operating bolt can be extended or withdrawn. An M2 unit can also be made so that one key is retained until the other key is inserted and the bolt operated. The previously retained key may now be withdrawn, but the last key inserted is retained.

Multi-lock units can be made with any number of locks operating together. The only size limitation is that imposed by the dimensions of the equipment on which the interlock is to be installed.

Note: When describing the locks of multiple-lock interlocks list the individual locks starting from the bolt projection end. Avoid use of the words "upper" or "lower" since Kirk Interlocks may be mounted in many different positions.

HOW KIRK KEY INTERLOCKS ARE USED

Kirk Key Interlocks can be applied to all kinds of moving members, whether operated electrically, mechanically, or otherwise. All interlocking applications fall into one of three categories: sliding, latching, and detachable.

INTERLOCKING SLIDING MEMBERS

FIG. 8

Sliding-

Members slide past one another.

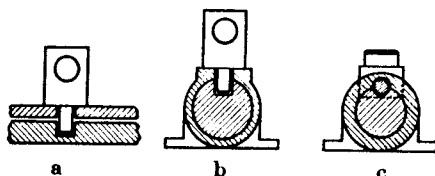

The interlock unit is mounted on the stationary or movable member. The other member is provided with a recess to allow the interlocking bolt to be extended for locking at the proper

position. In the unlocked position the bolt cannot be extended. The key is held.

This sliding principle can be applied to a rectilinear movement of a bar or an annular movement of a disc as in Fig. 8a. It can be applied to a rotational movement of a shaft as in Fig. 8b. It can also be applied to a mounting with a bolt extend into a recess, partly in the stationary and partly in the movable member as in Fig. 8c.

INTERLOCKING LATCHING MEMBERS

FIG. 9

Latching-

Movement of the member is accomplished by a latch.

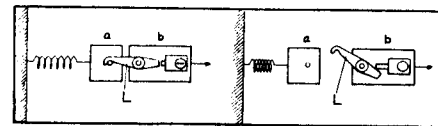

a and b, Fig. 9, are two associated members. Member a is attached to member b by a latch L. A motion of b in direction of arrow carries a with it.

An interlock is attached to b with bolt withdrawn. The key is held. The key is removable by the extension of the bolt which holds latch L in the disengaged position. b cannot now impart its motion to a.

INTERLOCKING DETACHABLE MEMBERS

FIG. 10

Detachable-

Members are detachable.

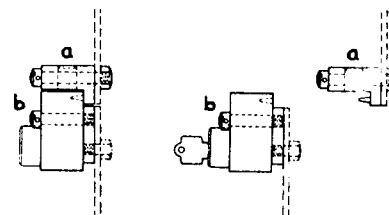

a and b, Fig. 10, are two members, one of which is detachable from the other. A detachable interlock is mounted at b and a latching block is mounted at a. Members a and b are locked together in position at left and detached at right.

A control key inserted in the interlock and turned, withdraws the bolt, permitting member a to be detached from b. The control key is retained in the lock as long as the two members, a and b, are separated. The control key can be removed from the lock and is available for interlocking only when members a and b have been brought back to their original position and the key is turned, extending the locking bolt into the socket.

CORRECT MOUNTING

Key interlocks should not be mounted so that the lock cylinder is upside down. The interlock is mounted correctly when the word YALE on the lock cylinder is right side up as viewed from the front. If desired, the lock may be mounted on its side so that the word YALE is vertical. The interlock is mounted incorrectly when the word YALE is upside down.

The following pages describe the dimensions and uses of the commonly used standard interlock units manufactured by R&IE. Following these descriptive pages are 20 pages of application ideas for key interlocking.

The designer or engineer, having familiarized himself with the fundamentals of key interlocking, may readily devise his own system layout. By consulting the descriptive pages, he can specify the interlocks and related equipment he needs. A complete sample order is filled out on Page 16.

A large number of special interlocking devices are available for special, unusual or more complex interlock arrangements. For reasons of simplicity, these devices have not been described herein.

TYPE T - TRANSFER

A type T interlock is an assembly of two or more locks in a single housing. These locks are designed to retain one or more keys while the remaining keys are withdrawn. All keys must be inserted in the interlock before the initially retained keys can be removed. After the retained keys are removed, those which have been inserted are retained.

Usually the need of a transfer lock can be eliminated by the use of multi-unit interlocks mounted on their respective devices, making it unnecessary to go through an additional transfer lock operation.

A single lock type T unit may be used with Types S, SS, or K auxiliary switches as a key operated switch where no locking bolt action is required.

A special type T interlock is available with three individual locks designed to operate in another manner than that explained above. When any one key is removed from its lock, the other two keys are held. When required, special multi-lock transfer units may be obtained to release keys in any predetermined sequence. These special transfer units can be of considerable value in complicated process control operations.

The Type T housing is made of bronze bar stock, drilled for mounting with $\frac{3}{8}$ " x $1\frac{3}{4}$ " flister head bolts.

Two to four-lock assemblies are mounted with two bolts (Fig. 18), while those with five or more locks are mounted with four bolts (Fig. 19).

Transfer locks are not actually interlocks. There is no operating bolt projection through base for locking any moving part.

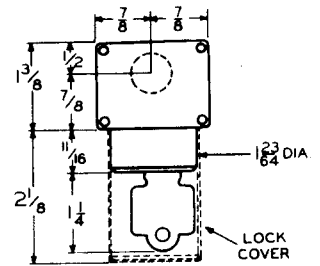

FIG. 17
Type M3T
Interlock

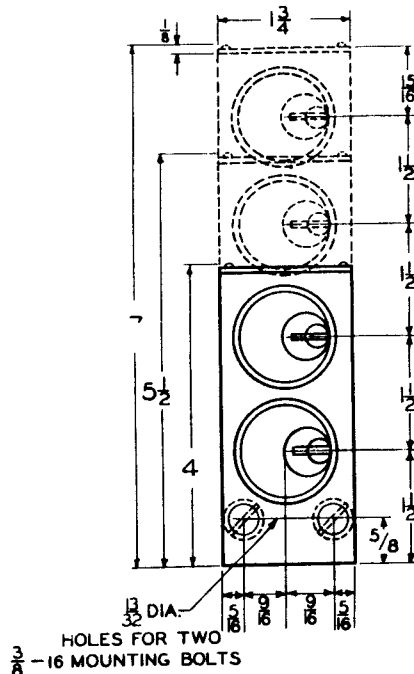
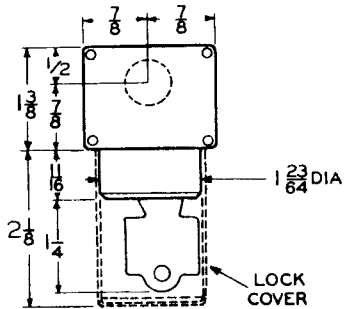

FIG. 18

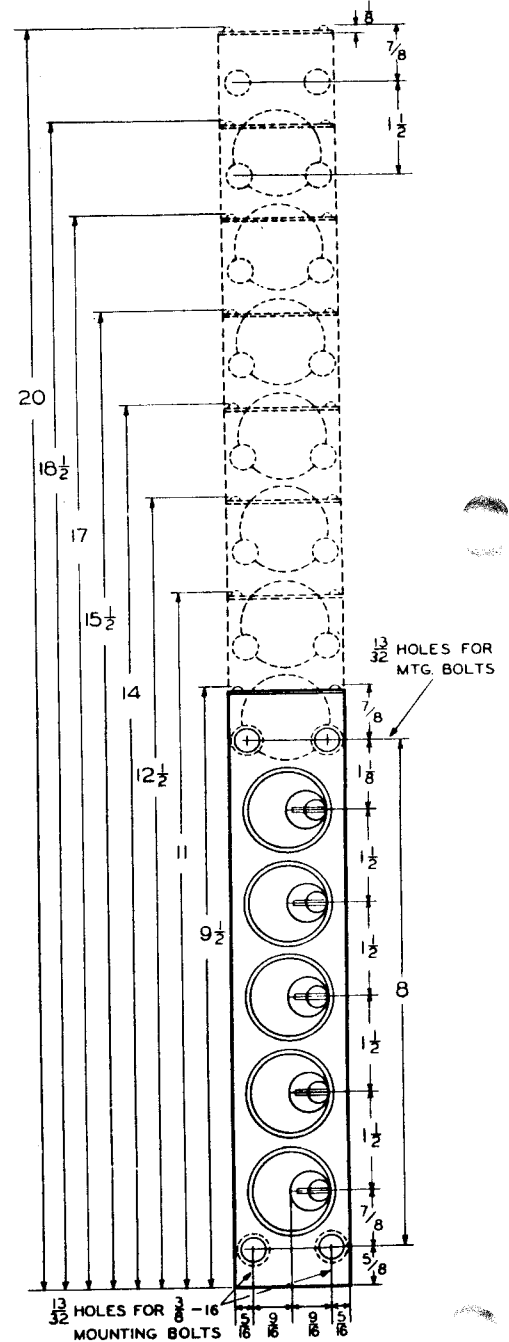

FIG. 19

5 TO 12 LOCKS

SOLENOID KEY RELEASE UNIT

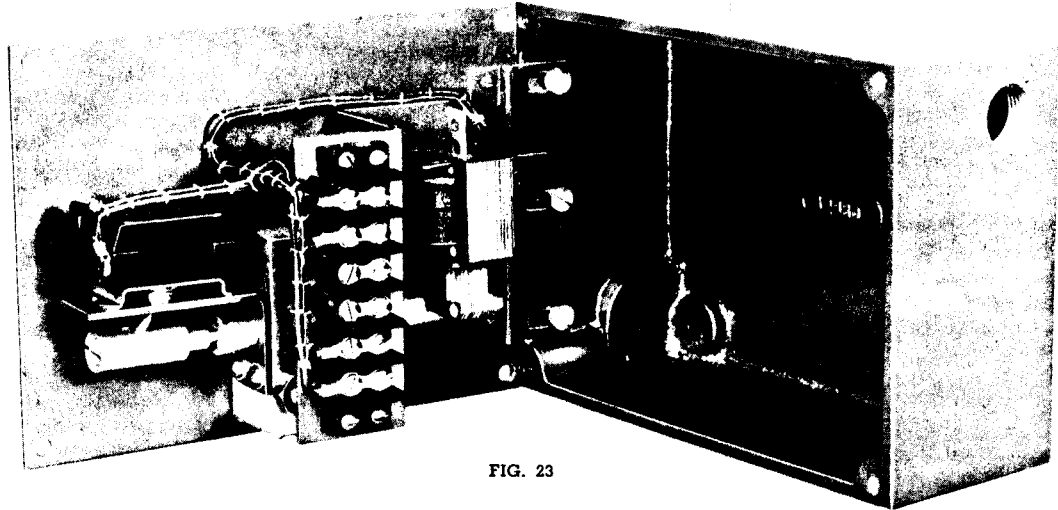

FIG. 23

The Solenoid Key Release Unit is housed in a box which can be front or back panel mounted—for indoor or outdoor service, with or without a weatherproof gasket.

This unit normally consists of an interlock, a solenoid arranged to permit removal of the interlock key in response to an external electric signal, an indicating light to show when the key can be removed, and an auxiliary switch operated in response to the withdrawal of the interlock key.

The interlock key is normally released when the external circuit is energized. However, if desired, the key release units can be arranged to permit removal of the key when the circuit and solenoid are de-energized.

The auxiliary switch is a quick-make, quick break device which operates when the interlock key is turned. A double-pole, single throw switch is normally provided with the key release units.

If desired, a push button can be furnished connected in series with the solenoid, so as to control the operation of the solenoid. The push button can be furnished with any of the solenoid key release units. The signal lamp, when furnished with the push button, indicates when the solenoid can be energized by operating the push button.

Various electrical and mechanical combinations of this unit are manufactured. All in all, 512 different combinations are available.

Fig. 24 shows a Kirk solenoid key release unit with a single key being retained. This unit has a signal lamp which lights when the key can be removed.

TYPICAL APPLICATIONS

These units are usually used in combination with other Kirk interlocks. A few examples of their application might be:

First, the protection of electrical equipment and an operator's life by preventing him from entering a breaker vault or operating a disconnect switch except when the breaker is open.

The solenoid of the key release unit is energized when the breaker is open so as to permit removal of the key. Removal of the key operates the auxiliary switch and opens the closing circuit of the breaker. The key can then be used in conjunction with other Kirk interlocks to enter the breaker vault and/or operate the disconnect switch.

Second, the tying together of two or more remotely located key interlock systems. For example, two key release units are used, one unit at each location. These units are connected together electrically so as to function as a two-key transfer unit. The solenoid of each unit is connected to a power supply through the auxiliary switch of the second unit. A key can then be removed from its release unit only when the other key is in its retained position in its release unit.

For a typical solenoid key release application, see Scheme 71.

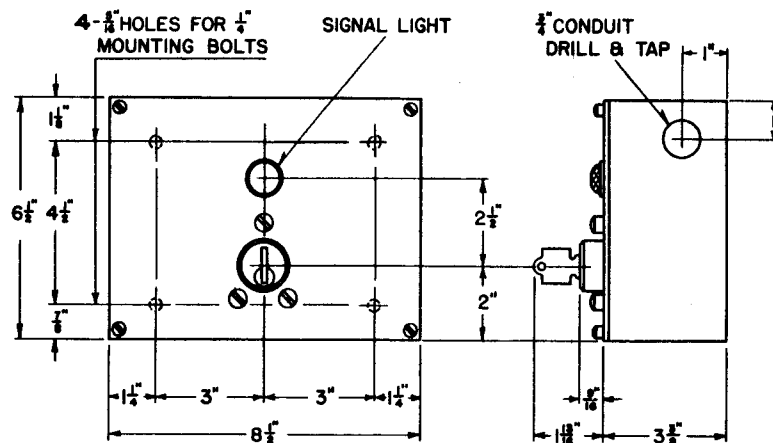

FIG. 24

TIME DELAY KEY RELEASE UNIT

The Time Delay Key Release Unit is housed within a box which can be front panel or back panel mounted.

The Unit comprises two type F interlocks, a push-button contactor, a timing device and by-pass relay, a solenoid and signal light for indication.

Fig. 25 illustrates the unit in its normal position with a key retained in its lock. A second or initiating key is introduced and turned, which starts the time delay relay. After a given delay, the solenoid is energized, permitting the previously held key to be withdrawn for further operations. (The signal light shows the operator when the solenoid has been energized). After removing the initially held key, the initiating key is retained.

Should an operator accidentally remove the initiating key during the time delay period, the timing device instantly returns to its original position.

The Time Delay Key Release Unit has many possible applications where it can be combined with the basic standard Kirk Interlocks to protect life, property or product.

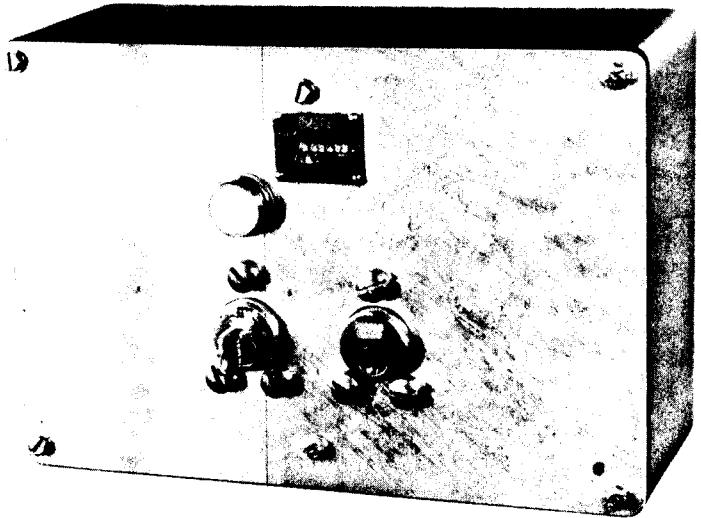

FIG. 25

TYPICAL APPLICATIONS

Cage or Enclosure

Such applications are many. For example, the protection of an operator's life by preventing him from entering a cage or guarded enclosure where there is rotating equipment, until all rotational movement has stopped.

Radio and Television Transmitting Tubes

Another application is the protection of equipment such as radio and television transmitting tubes. Here it is necessary

to have the filament connected to its power supply for a predetermined minimum length of time before it is possible to apply the plate voltage and begin the normal operation of the tube.

Processing or Mixing

A third application is the positive controlling of a process or a mixture so as to guarantee the quality of a manufactured product, or to see that proper sequence is used in the blending or mixing of various substances, or that the proper time elapses before the next stage of manufacturing takes place.

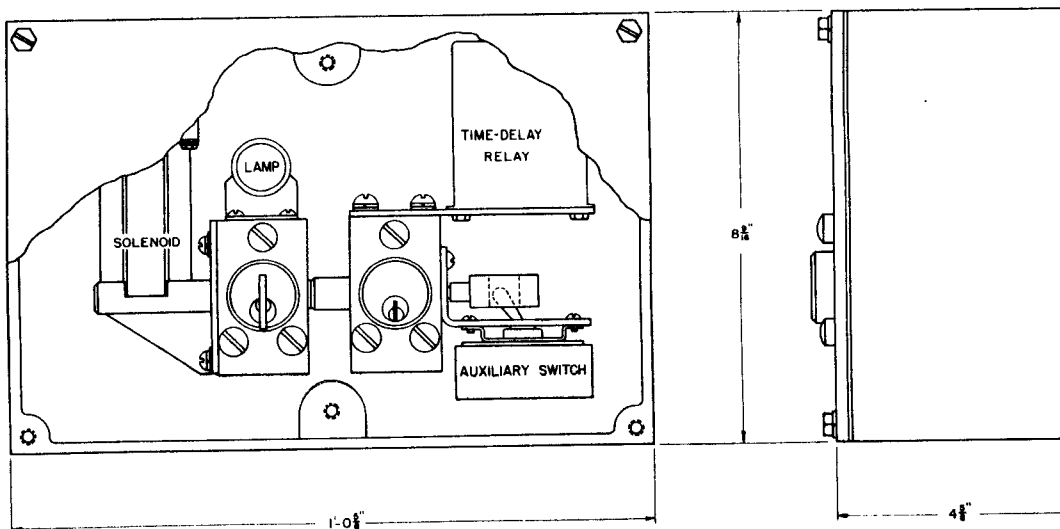

FIG. 26

TYPE S & SS AUXILIARY SWITCHES

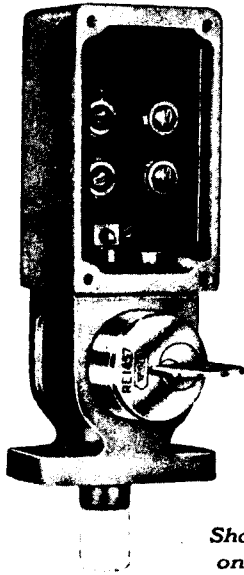

FIG. 27
Shown mounted
on Type B lock

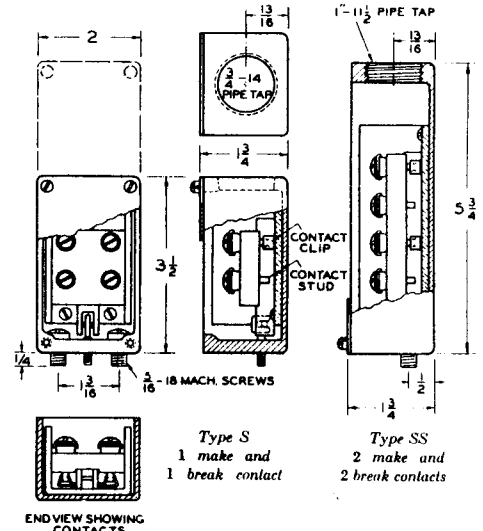

FIG. 28

FIG. 29

S and SS auxiliary switches can be added to any of the standard interlocks. The switch is mounted on top of the interlock as shown above. This is a slow-make, slow-break switch, moving in direct response to the movement of the key. It is used primarily as a disconnect switch in a control circuit, but it can be used as a load make or break switch.

The switch has a continuous current rating of 50 amperes, with a maximum temperature rise of 30°C. Its withstand voltage is 2500 Volts (line to ground). The following table lists the switch's interrupting ability for a given number of operations.

The switch is normally mounted with the cover on the same

side as the lock. However, this arrangement can be reversed so that the switch and lock face in opposite directions. This way interlocks can be mounted for operation from the front of a panel while wiring runs into the back of the panel. The removable cover at the back permits easy connection to the switch terminals.

The dimensions of any combination S or SS switch with interlocks (B, F, D, and T), can be obtained by adding the switch dimensions to the interlock device desired. Examples are shown below.

Other information pertaining to these switches is listed in the following table:

No. of Operations (Min.)	Amperes interrupted at given voltages			
	A. C.			D. C.
	120	240	480	
1,000	15	12	8	Test Data Not Complete
10,000	10	9	5	

Type of Switch	Type S	Type SS
Circuit.....	2	4
Make.....	1	2
Break.....	1	2
Conduit Opening.....	3/4"	1"

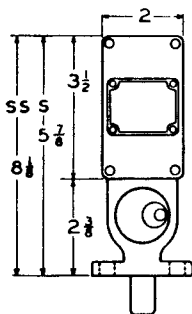

FIG. 30
Type BS

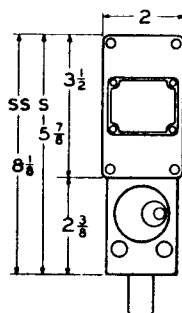

FIG. 31
Type FS

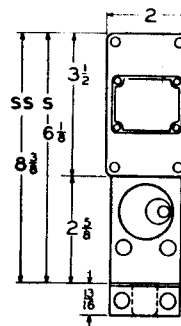

FIG. 32
Type DS

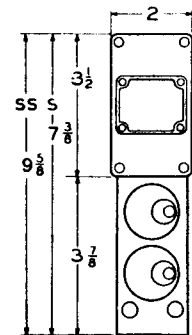

FIG. 33
M1TS

TYPE K AUXILIARY SWITCH

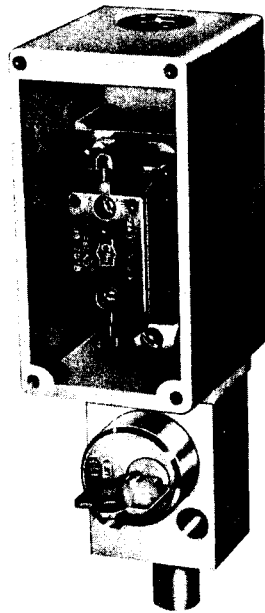

FIG. 34

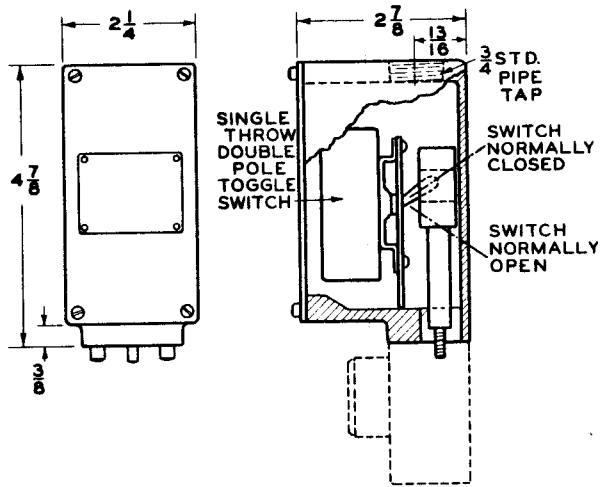

FIG. 35

The Type K auxiliary switch is a quick-make, quick-break device capable of handling relatively large currents. The assembly normally uses a Cutler-Hammer extra heavy duty snap switch, catalog No. 7410. This switch is rated 20 amperes, 250 volts a-c or d-c, (non-inductive), or at 2 H.P., 125/250 volts.

The snap switch is operated in response to the movements of the interlock lock bolt. However, the Type K switch remains in its initial position until the lock bolt has traveled substantially the full $\frac{3}{4}$ " distance to its second position. The Type K auxiliary switch therefore does not give an indication as to initial movement of the lock bolt.

The switch is normally mounted with the cover on the same side as the lock, but can be mounted so that the cover faces away from the lock. This arrangement makes for easy access to the switch from the back of a panelboard, for instance.

TYPICAL APPLICATIONS

The Type K auxiliary switch can be used as a key operated power switch. A few examples of its application might be as follows:

First, as an elevator control switch which enables only authorized personnel to use the elevator.

Second, the protection of photo-sensitive material by permitting the turning on of lights only under prescribed conditions—such as when the "light-locks" have been locked in a safe position.

Third, as motor control switch, either independently or in conjunction with an interlock system.

TYPE P PADLOCK

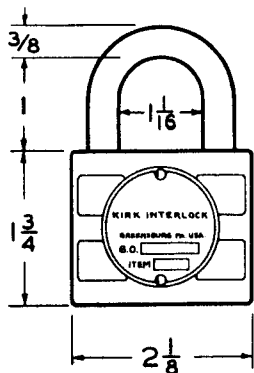

FIG. 36

Special heavy-duty padlocks are provided for the Kirk Interlock System, where it is necessary to incorporate this type of lock. These padlocks have cast bronze housings and bronze shackles. They also have a special 6-pin tumbler arrangement which permits inter-changeability with all other Kirk Key Interlocks.

Three padlocks are available. The standard model is similar to ordinary padlocks in that the key may be removed when the shackle is either open or closed. A second type is made so that the key is removable only when the shackle is closed.

The third padlock is distinctively different. It is operated with two keys. Either key may be removed whether the shackle is open or closed, but its removal immediately makes the other key non-removable.

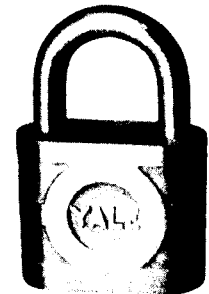

FIG. 37

OPTIONAL ITEMS

(AVAILABLE AS EXTRAS)

DUST COVERS

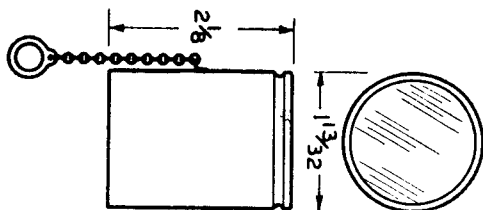

FIG. 38

Covers that fit tightly over the lock cylinder and key are designed for protection against any condition—moisture, dirt and sleet. The cover can be used when the key is in place or removed. The front part is transparent, allowing the key and lock interchange number to be visible. One end of the chain is attached to the side of the cover and serves to retain the cover when removed. The other end is held under the mounting bolt head. For multiple lock interlocks the chains are grouped to a single mounting ring.

MOUNTING BOLTS

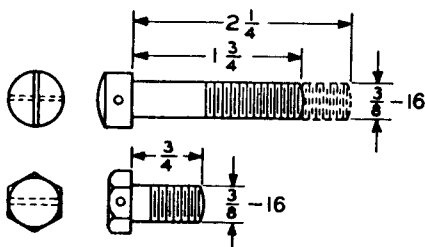

FIG. 39

Bolts for interlock mountings are of one size, $\frac{3}{8}$ "-16 made of Everdur. The heads are provided with a through hole in which a sealing wire can be placed. Standard styles are:

- a—Hex Head— $\frac{3}{4}$ " long
- b—Hex Head— $1\frac{1}{8}$ " long
- c—Fillister Head Machine Screw— $1\frac{3}{4}$ " long
- d—Fillister Head Machine Screw—2" long
- e—Fillister Head Machine Screw— $2\frac{1}{4}$ " long
- f—Fillister Head Machine Screw— $2\frac{1}{2}$ " long

SEALS

Seals can be used on interlock mountings to prevent unauthorized tampering. The interlock can be removed easily and quickly by removing the mounting bolts and breaking the seal. The broken seal gives a plain indication that the interlock has been removed. All exposed bolt heads are provided with the necessary drilling for seals. This includes mounting bolts and screws for attaching covers, where needed.

I-T-E supplies a special seal. It is a $\frac{3}{8}$ " slotted head seal

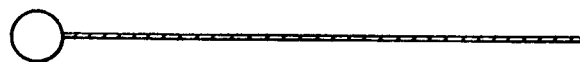

FIG. 40

with 4-ply "Crimped" 30 gauge stainless steel wire. This wire has no corrosive effect on the housing.

This seal is provided without extra charge on solenoid key release and time-delay key release units, where it is particularly necessary. It can be furnished for any other lock at a slight extra cost. Sealing irons must be purchased separately.

DUPLICATE KEYS

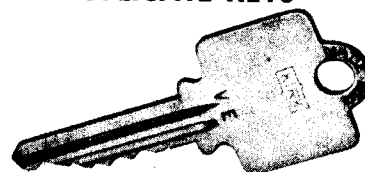

FIG. 41

Each interlock is supplied with a key in its lock. These keys are needed during installation of the interlocks on equipment. This then provides more keys than are actually necessary for operation of the interlock system. When the interlocks have been installed, all extra keys should be removed from the system and destroyed or retained by a responsible person.

If additional keys are required because of loss or damage, they can be supplied only on the purchaser's authorized order.

AUTOMATIC LATCHING BOLT INTERLOCK

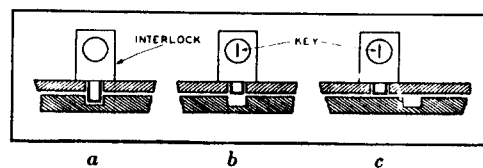

FIG. 42

Typical of the many special assemblies which can be developed, is the latching bolt or automatic locking action interlock. The locking bolt on this type of interlock is automatically extended when the receiving or movable member is moved into the lockable position.

Referring to Fig. 42, assume that the latching bolt interlock is used. The key can be removed when the bolt is in the withdrawn position, as in Fig. 42c. When the movable member is returned to the lockable position as shown in 42b, the locking bolt will automatically extend itself into the locked position as shown in 42a.

This type of automatic locking action can be specified for any of the standard Kirk Interlocks. It can be identified by suffix letter "G" when ordering. For example, a Type B interlock with automatic locking action is known as a Type BG interlock.

INTERLOCK OPERATING DETAILS

LOCKING BOLT POSITION

In describing the operation of Kirk Interlocks, by far the most important characteristic is the position of the bolt at a given position of the key. Two methods are used to describe the position of the bolt.

First, the interlock must be described in terms of the operating position of the device on which it is mounted. The key to the interlock may be removed when the device is either:

(a) *Locked Open (L-O)*. This symbol on an interlock diagram indicates that the key is removable when the device (a switch, valve, door, etc.) is locked in the open position.

(b) *Locked closed (L-C)*. This symbol indicates that the key is removable when the device is locked in the closed position.

(c) *Locked Open or Closed (L-O-C)*. This symbol indicates that the key is removable when the device is locked either in the open or closed position.

(d) *Locked Neutral (L-N)*. This symbol indicates that the key is removable when the device is locked in the neutral position.

(e) *Locked Ground (L-G)*. This symbol indicates that the key is removable when the device is locked in the grounded position.

Second, the interlock must be described in terms of the locking bolt's relation to the key. A given key is removable from its lock in one position of the bolt only—that is, the position which is indicated on the interlock system plan. All keys must be

shows an "M3" interlock designated as an M3-EWW, indicating that the key at the operating bolt end is removable when locking bolt is extended. When the locking bolt is withdrawn the other two "W" keys are removable.

Figure 43d shows an "M4-EEEW" indicating that the three keys at mounting bolt end are removable and the other key is held when the locking bolt is extended.

Figure 43e shows a transfer lock in which there is no extended operating bolt. This lock is also termed M4-EEEW. All three "E" keys must be placed in their locks and operated before the "W" key can be removed

BOLT TRAVEL AND PROJECTION

The normal travel of the locking bolt from the withdrawn to the extended position is $\frac{3}{4}$ ".

Occasionally there is a requirement for more than one locking function from the same interlock. To solve such a problem, a combination of locking bolt extensions has been arranged on the same assembly. (Standard bolt travel $\frac{3}{4}$ " and one half normal travel, $\frac{3}{8}$ ".)

The normal projection of the interlock bolt when in the withdrawn position is 1". Other standard lengths are 0", $\frac{1}{4}$ ", $\frac{3}{8}$ ", 1", 2", and 3". Unless otherwise called for, 1" projection will be supplied. The specified length should be suffixed to the letters designating the type. Thus figure 43b with a 3" bolt projection is specified Type M2F-3-EE. Any projection other than standard can be furnished, at extra cost.

LOCK NUMBERING

When interlocks are used, they have keys that are to interchange with other interlocks. It will help the purchaser in making studies if he designates which locks have keys that are the same as other locks and keys. Designations such as A-1, A-2, B-1, and B-2 can be used. All A-1 locks have the same combination, all A-2 locks the same combination, etc. These designations are called key interchange numbers.

I-T-E assigns lock numbers on receipt of interlock orders. Where two or more locks with the same interchange number are used, two or more locks with the same RE lock number will be used.

These RE lock numbers are marked on the face of the lock above the word "Yale" (see Fig. 44). If the purchaser desires,

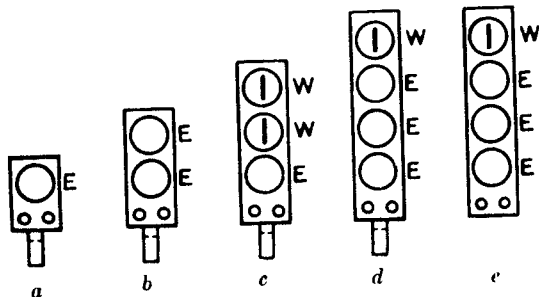

FIG. 43

in their respective locks in order to operate the locking bolt. The following designations indicate the positions in which the key will be released:

- E—Bolt Extended, Key Removable
(also—Bolt withdrawn, Key Held)
- W—Bolt Withdrawn, Key Removable.
(also—Bolt extended, Key Held)

The interlock shown in Figure 43a is designated as "E", as the key is removable when the locking bolt is extended to lock the apparatus. As interlocking sequences usually require the associated devices to be locked in one position on successive order, it seldom occurs that a single unit "W" interlock is necessary as the key is removable when the interlock bolt is withdrawn. In common applications, this would leave the device unlocked. In the multiple lock interlocks "M", however, keys may be required to be removable in either the locked or unlocked position for each lock.

Figure 43b shows an M2 interlock which has both keys lettered "E" indicating that both keys are removable when bolt is extended and are held when bolt is withdrawn. Figure 43c



FIG. 44

the locks will also be marked with interchange numbers. These are marked on both sides of the lock face (see Fig. 44) so that they can be read easily regardless of the manner in which the locks are eventually mounted.

The key is also marked with lock number and interchange number. The lock number appears on the same side as YALE. The interchange number is marked on the reverse side, if the interchange number is also desired.

"Yale" locks are furnished as standard. However, any other type lock can be furnished if required by purchaser.

INTERLOCK SYMBOLS

(Used on Kirk Interlock Arrangement Drawings)



Device normally open.



Device normally closed.



Direction of key transfer.

A-1 A-2 A-3

Key interchange number.



*Interlock with key held.
Device in position as shown.*



*Interlock with key removed.
Device in position as shown.*



Interlock used to lock device open.



Interlock used to lock device closed.



*Interlock used to lock device open
and closed.*



Multi-lock interlock.



*Interlock with master lock.
(also called apartment lock).*



*Detachable latch interlock.
Type D.*

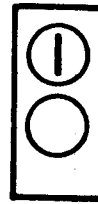

*Transfer interlock.
Type T*



*Padlock.
Type P*



*Key Interchange num-
ber (showing key held).*

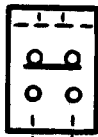

*Auxiliary switch 1 make,
1 break. Type S*

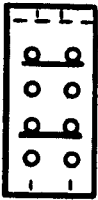

*Auxiliary Switch.
2-make, 2-break
Type SS*



*Auxiliary switch.
Type K.*



*{ Key released after time
delay.*

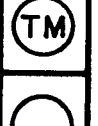

*Time-delay key
release unit.*



{ Initiating Lock

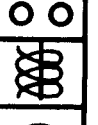

*Solenoid key release
unit. Key released when
solenoid is E, energized
or D, deenergized).*



APPLICATION SCHEMES

FUNDAMENTAL CONCEPTS

In order to lay out more complicated interlock schemes, it is necessary to understand the simplest applications. On this page, the basic concepts of interlocking are discussed.

INTERLOCKING A SINGLE UNIT IN ONE POSITION

If it is desired to secure a device in the open position, an interlock is used as in Fig. 45. The possession of the key indicates

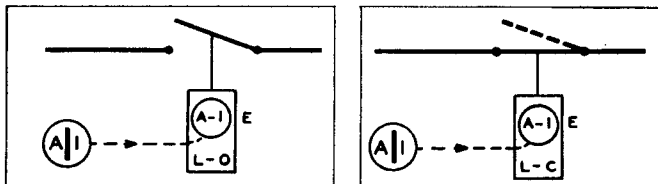

FIG. 45

FIG. 46

that the device is in the open position and is locked by the extension of the interlock bolt. When the key is inserted in the lock and turned to withdraw the interlock bolt, the device is free to operate to the closed position and the key is held in the lock.

When a device is to be locked only in the closed position an interlock is used as shown in Fig. 46. The possession of the key indicates that the device is locked in the closed position, as the interlock bolt has been extended to remove the key. When the key is inserted in the lock and turned to withdraw the interlock bolt, the device is free to operate to the open position and the key is held in the lock.

INTERLOCKING A SINGLE UNIT IN TWO POSITIONS

Two methods are used in interlocking a device in both the open and closed position. The first method requires only one interlock as shown in Fig. 47. The interlock bolt is extended in both the open or closed positions. This is accomplished with two recesses in the device which is being interlocked, each coinciding with the locking bolt in one position.

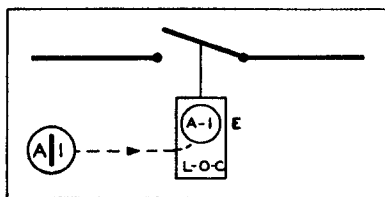

FIG. 47

The possession of the key indicates that the locking bolt is extended and that the device is locked in either the open or closed position. Furthermore, the device cannot be operated until the key is inserted and turned in the lock to withdraw the locking bolt. The key cannot be removed from the lock in an intermediate position, but in the fully open or closed positions only. In this application, possession of the key however gives no indication as to whether the device is locked closed or open.

INTERLOCKING TWO UNITS IN TWO POSITIONS

The other method for locking in both the open and closed positions requires two interlocks as shown in Fig. 48. Possession

of Key A-1 indicates that the device is locked open; possession of key A-2 indicates that the device is locked closed. The device is shown normally open, therefore, key A-1 is free and the L-O interlock bolt is extended into its recess provided in the movable number, while key A-2 is held and the L-C interlock bolt is withdrawn. To close the device, insert key A-1 in the L-O lock, turn to withdraw bolt of L-O interlock which permits the device to be operated. Now the device can be moved to the closed position, and key A-2 can be turned to extend the bolt of the L-C interlock into its recess, locking the device closed. This releases key A-2

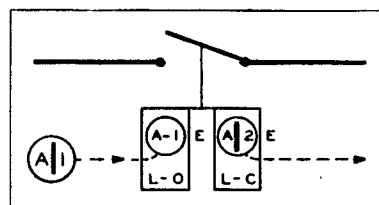

FIG. 48

from the L-C interlock. Meanwhile key A-1 is held in the L-O interlock, as its withdrawn bolt cannot be extended.

This method is used more often than the single two-position interlock, shown in Fig. 47, due to its adaptability to sequence operations. Also, the possession of key A-1 or A-2 indicates that the device is locked open, or locked closed, respectively.

SEQUENCE INTERLOCKING

With the fundamentals developed above, it is quite simple to extend the application to the interlocking of two or more devices in a desired sequence.

Two devices are shown in Fig. 49. In operation they are not closed at the same time. With the interlocks arranged as shown,

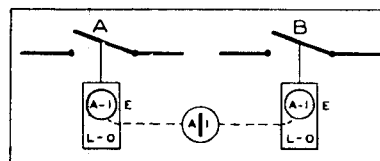

FIG. 49

only one key is required in the interlocking system. Both devices are shown open, therefore, the key is free. To close any one device the key is inserted and turned in that particular lock to withdraw the interlock bolt. The key is held in this lock until the device is again locked open. This simple interlocking sequence lends itself to a multitude of applications. The procedure is the same for two devices, neither of which is to be opened at the same time. L-C interlocks are used in the same manner as Fig. 49.

For switches there may be substituted pipe valves, control rods, doors, safety guards, manhole covers, etc. which are locked open or closed, corresponding to the locking indicated for the switches.

These instructions do not purport to cover all details or variations in equipment nor to provide for every possible contingency to be met in connection with installation, operation, or maintenance. Should further information be desired or should particular problems arise which are not covered sufficiently for the purchaser's purposes the matter should be referred to Gould-Brown Boveri.

Power Systems Division
Theobald Ave., Greensburg, Pa. 15601

Bulletin IB-15.2-1A (Supersedes IB-1725 dated 77.)
Printed in U.S.A. 1M-CMH-679

 **GOULD-BROWN BOVERI**
A joint venture of I-T-E Imperial Corporation and Brown Boveri Power Delivery, Inc.