

SIEMENS

MICROMASTER 420

0.12 kW - 11 kW

Operating Instructions (Compact)

Issue 10/06



Warnings, Cautions and Notes

The following Warnings, Cautions and Notes are provided for your safety and as a means of preventing damage to the product or components in the machines connected.

Specific Warnings, Cautions and Notes that apply to particular activities are listed at the beginning of the relevant chapters and are repeated or supplemented at critical points throughout these chapters.

Please read the information carefully, since it is provided for your personal safety and will also help prolong the service life of your MICROMASTER 420 Inverter and the equipment you connect to it.



WARNING

- This equipment contains dangerous voltages and controls potentially dangerous rotating mechanical parts. Non-compliance with **Warnings** or failure to follow the instructions contained in this manual can result in loss of life, severe personal injury or serious damage to property.
- Only suitable qualified personnel should work on this equipment, and only after becoming familiar with all safety notices, installation, operation and maintenance procedures contained in this manual. The successful and safe operation of this equipment is dependent upon its proper handling, installation, operation and maintenance.
- The DC link of all MICROMASTER modules remains at a hazardous voltage level for 5 minutes after all voltages have been disconnected. Therefore always wait for 5 minutes after disconnecting the inverter from the power supply before carrying out work on any modules. The drive unit discharges itself during this time.
- This equipment is capable of providing internal motor overload protection in accordance with UL508C section 42. Refer to P0610 (level 3) and P0335. Motor overload protection can also be provided using an external PTC via a digital input.
- This equipment is suitable for use in a circuit capable of delivering not more than 10,000 symmetrical amperes (rms), for a maximum voltage of 230/460 V when protected by an H or K type fuse, a circuit breaker or self-protected combination motor controller controller (for more details see Operating Instructions Appendix F).
- Use Class 1 60/75 °C copper wire only with the cross-sections as specified in the Operating Instructions..
- The mains input, DC and motor terminals carry dangerous voltages even if the inverter is inoperative, wait 5 minutes to allow the unit to discharge after switching off before carrying out any installation work.

NOTES

- Before installing and commissioning, please read these safety instructions and warnings carefully and all the warning labels attached to the equipment.
 - Make sure that the warning labels are kept in a legible condition and replace missing or damaged labels.
 - Maximum permissible surrounding ambient temperature is 50°C.
-

Contents

1	Installation	4
1.1	Clearance distances for mounting	4
1.2	Mounting dimensions	4
2	Electrical Installation	5
2.1	Technical Specifications	5
2.2	Power Terminals	6
2.3	Control terminals	6
2.4	Block diagram	7
3	Factory setting	8
3.1	50/60 Hz DIP switch	8
4	Communications	9
4.1	Establishing communications MICROMASTER 420 ⇔ STARTER	9
4.2	Establishing communications between the MICROMASTER 420 ⇔ AOP	9
4.3	Bus interface (CB)	10
5	BOP / AOP (Option)	11
5.1	Buttons and their Functions	11
5.2	Changing parameters using as an example P0003 "Access level"	12
6	Commissioning	13
6.1	Quick commissioning	13
6.2	Commissioning the application	15
6.2.1	Serial Interface (USS)	15
6.2.2	Selection of command source	16
6.2.3	Digital input (DIN)	16
6.2.4	Digital output (DOUT)	17
6.2.5	Selection of frequency setpoint	17
6.2.6	Analog input (ADC)	18
6.2.7	Analog output (DAC)	19
6.2.8	Motor potentiometer (MOP)	20
6.2.9	Fixed frequency (FF)	20
6.2.10	JOG	21
6.2.11	Ramp-function generator (HLG)	21
6.2.12	Reference/limit frequencies	22
6.2.13	Motor control (V/f)	22
6.2.14	Inverter/motor protection	24
6.2.15	Inverter-specific Functions	25
6.3	Series commissioning	28
6.4	Parameter reset of factory setting	28
7	Displays and messages	29
7.1	LED status display	29
7.2	Fault messages and Alarm messages	29

1 Installation

1.1 Clearance distances for mounting

The inverters can be mounted adjacent to each other. If they are mounted on top of each other, however, a clearance of 100 mm has to be observed.



Fig. 1-1 Clearance distances for mounting

1.2 Mounting dimensions

	Frame Size	Drilling Dimensions		Tightening Torque	
		H mm (Inch)	W mm (Inch)	Bolts	Nm (lbf.in)
	A	160 (6.30)	–	2xM4	2.5 (22.12)
	B	174 (6.85)	138 (5.43)	4xM4	
	C	204 (8.03)	174 (6.85)	4xM4	

Fig. 1-2 Mounting dimensions

2 Electrical Installation

2.1 Technical Specifications

1 AC 200 V – 240 V

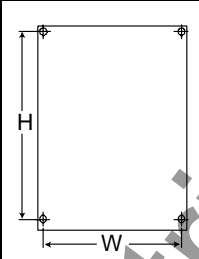
Order No. 6SE6420-	<u>2AB</u> <u>2UC</u>	11- 2AA1	12- 5AA1	13- 7AA1	15- 5AA1	17- 5AA1	21- 1BA1	21- 5BA1	22- 2BA1	23- 0CA1
Frame Size		A					B			C
Inverter Output Rating	kW hp	0.12 0.16	0.25 0.33	0.37 0.5	0.55 0.75	0.75 1.0	1.1 1.5	1.5 2.0	2.2 3.0	3.0 4.0
Input Current	A	1.8	3.2	4.6	6.2	8.2	11.0	14.4	20.2	35.5
Output Current	A	0.9	1.7	2.3	3.0	3.9	5.5	7.4	10.4	13.6
Recommended Fuse	A 3NA	10 3803	10 3803	10 3803	10 3803	16 3805	20 3807	20 3807	32 3812	40 3817
Input Cable	mm ² AWG	1.0-2.5 17-13	1.0-2.5 17-13	1.0-2.5 17-13	1.0-2.5 17-13	1.0-2.5 17-13	2.5-6.0 13-9	2.5-6.0 13-9	4.0-6.0 11-9	6.0-10 9-7
Output Cable	mm ² AWG	1.0-2.5 17-13	1.0-2.5 17-13	1.0-2.5 17-13	1.0-2.5 17-13	1.0-2.5 17-13	1.0-6.0 17-9	1.0-6.0 17-9	1.0-6.0 17-9	1.5-10 15-7
Tightening Torque	Nm (lbf.in)	1.1 (10)					1.5 (13.3)			2.25 (20)

3 AC 200 V – 240 V

Order No. 6SE6420-	<u>2AC</u> <u>2UC</u>	11- 2AA1	12- 5AA1	13- 7AA1	15- 5AA1	17- 5AA1	21- 1BA1	21- 5BA1	22- 2BA1	23- 0CA1	24- 0CA1	25- 5CA1
Frame Size		A					B			C		
Inverter Output Rating	kW hp	0.12 0.16	0.25 0.33	0.37 0.5	0.55 0.75	0.75 1.0	1.1 1.5	1.5 2.0	2.2 3.0	3.0 4.0	4.0 5.0	5.5 7.5
Input Current	A	1.1	1.9	2.7	3.6	4.7	6.4	8.3	11.7	15.6	19.7	26.3
Output Current	A	0.9	1.7	2.3	3.0	3.9	5.5	7.4	10.4	13.6	17.5	22.0
Recommended Fuse	A 3NA	10 3803	10 3803	10 3803	10 3803	10 3803	16 3805	16 3805	20 3807	25 3810	32 3812	35 3814
Input Cable	mm ² AWG	1.0-2.5 17-13	1.0-2.5 17-13	1.0-2.5 17-13	1.0-2.5 17-13	1.0-2.5 17-13	1.0-6.0 17-9	1.0-6.0 17-9	1.0-6.0 17-9	2.5-10 13-7	2.5-10 13-7	4.0-10 11-7
Output Cable	mm ² AWG	1.0-2.5 17-13	1.0-2.5 17-13	1.0-2.5 17-13	1.0-2.5 17-13	1.0-2.5 17-13	1.0-6.0 17-9	1.0-6.0 17-9	1.0-6.0 17-9	1.5-10 15-7	2.5-10 13-7	4.0-10 11-7
Tightening Torque	Nm (lbf.in)	1.1 (10)					1.5 (13.3)			2.25 (20)		

3 AC 380 V – 480 V

Order No. 6SE6420-	<u>2AD</u> <u>2UD</u>	13- 7AA1	15- 5AA1	17- 5AA1	21- 1AA1	21- 5AA1	22- 2BA1	23- 0BA1	24- 0BA1	25- 5CA1	27- 5CA1	31- 1CA1	
Frame Size		A					B			C			
Inverter Output Rating	kW hp	0.37 0.5	0.55 0.75	0.75 1.0	1.1 1.5	1.5 2.0	2.2 3.0	3.0 4.0	4.0 5.0	5.5 7.5	7.5 10.0	11.0 15.0	
Input Current	A	2.2	2.8	3.7	4.9	5.9	8.8	11.1	13.6	17.3	23.1	33.8	
Output Current	A	1.2	1.6	2.1	3.0	4.0	5.9	7.7	10.2	13.2	19.0	26.0	
Recommended Fuse	A 3NA	10 3803	10 3803	10 3803	10 3803	10 3803	16 3805	16 3805	20 3807	20 3807	25 3810	35 3814	
Input Cable	mm ² AWG	1.0-2.5 17-13	1.0-2.5 17-13	1.0-2.5 17-13	1.0-2.5 17-13	1.0-2.5 17-13	1.0-6.0 17-9	1.0-6.0 17-9	1.5-6.0 15-9	2.5-10 13-7	4.0-10 11-7	6.0-10 9-7	
Output Cable	mm ² AWG	1.0-2.5 17-13	1.0-2.5 17-13	1.0-2.5 17-13	1.0-2.5 17-13	1.0-2.5 17-13	1.0-6.0 17-9	1.0-6.0 17-9	1.0-6.0 17-9	1.5-10 15-7	2.5-10 13-7	4.0-10 11-7	
Tightening Torque	Nm (lbf.in)	1.1 (10)					1.5 (13.3)			2.25 (20)			

2.2 Power Terminals

You can gain access to the mains and motor terminals by removing the front covers.

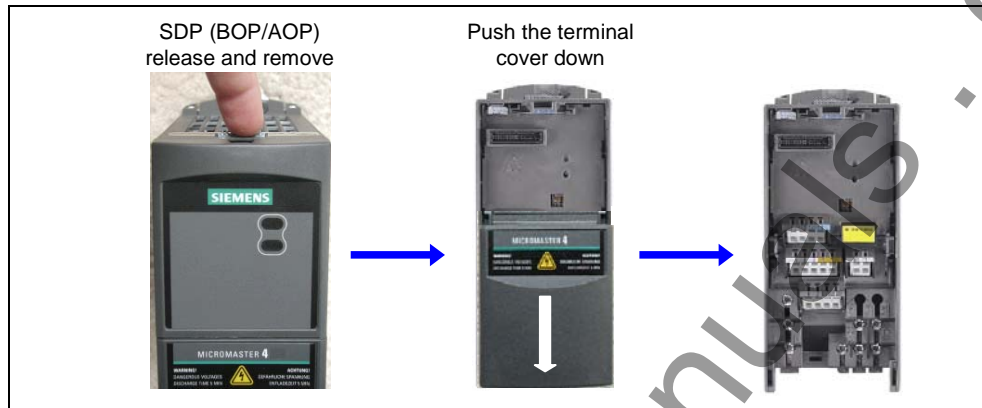

Fig. 2-1 Removing Front Covers

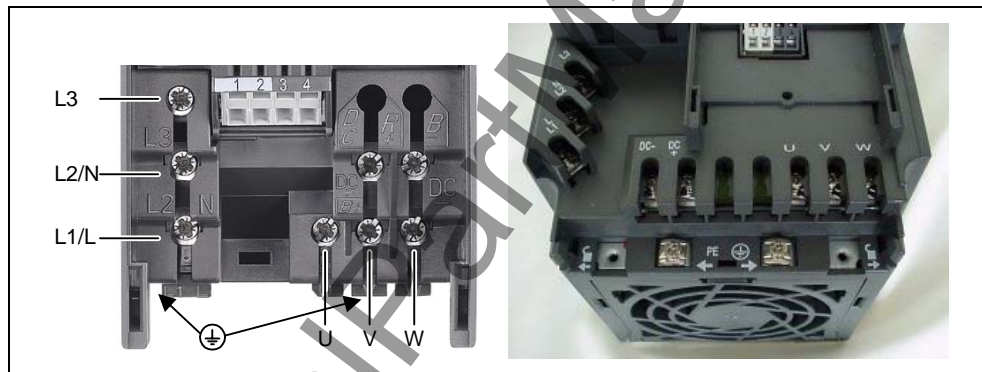
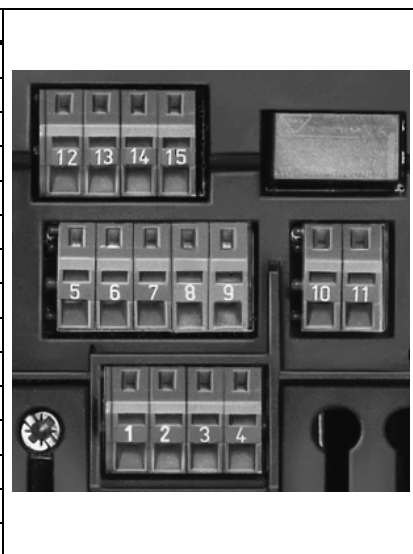

Fig. 2-2 Power Terminals

2.3 Control terminals

Terminal	Designation	Function
1	-	Output +10 V
2	-	Output 0 V
3	ADC+	Analog input (+)
4	ADC-	Analog input (-)
5	DIN1	Digital input 1
6	DIN2	Digital input 2
7	DIN3	Digital input 3
8	-	Isolated output +24 V / max. 100 mA
9	-	Isolated output 0 V / max. 100 mA
10	RL1-B	Digital output / NO contact
11	RL1-C	Digital output / Changeover contact
12	DAC+	Analog output (+)
13	DAC-	Analog output (-)
14	P+	RS485 port
15	N-	RS485 port



2.4 Block diagram

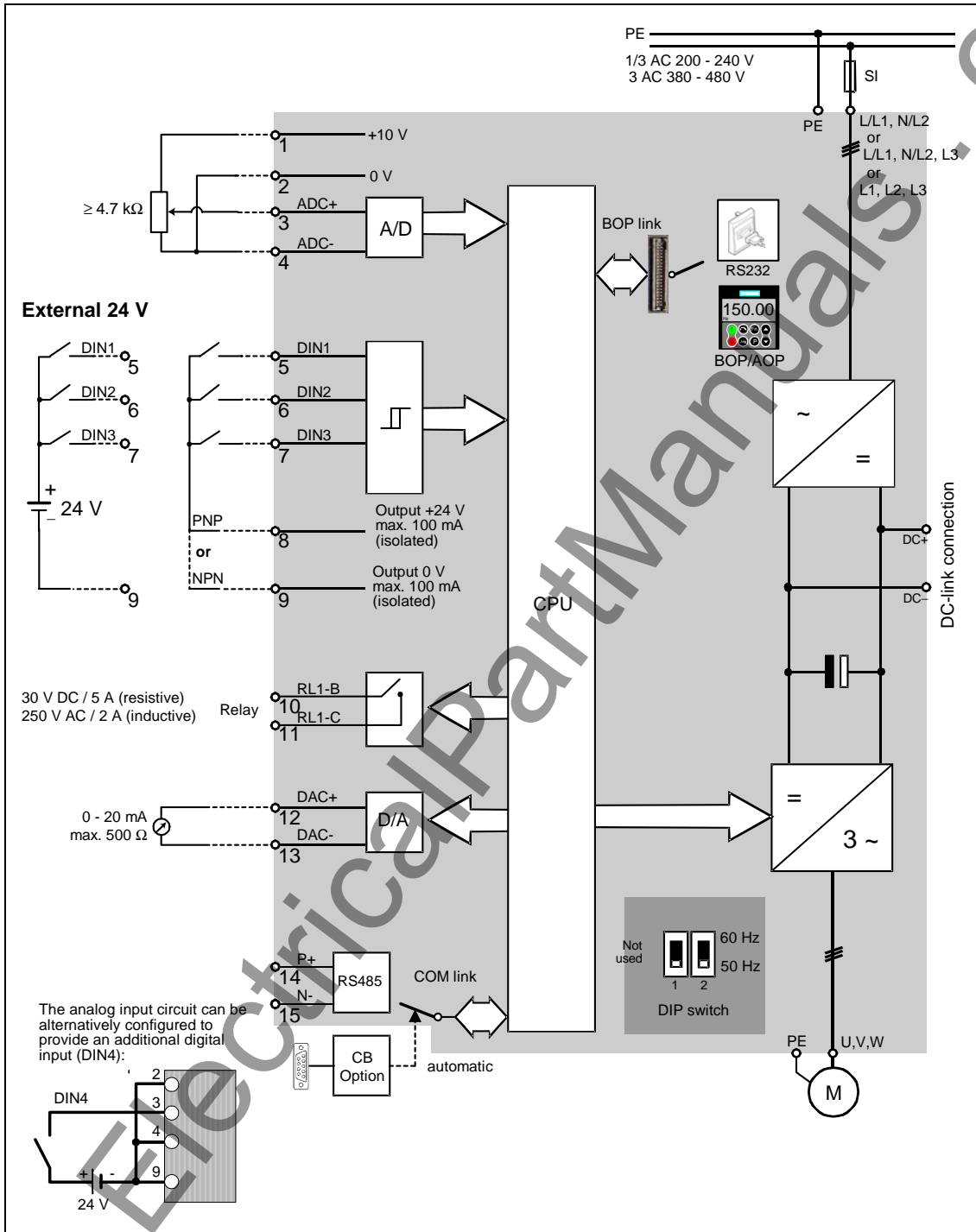

Fig. 2-3 Inverter block diagram

3 Factory setting

The MICROMASTER 420 frequency inverter is set in the factory so that it can be operated without any additional parameterization. To do this, the motor parameters set in the factory (P0304, P0305, P0307, P0310), that correspond to a 4-pole 1LA7 Siemens motor, must match the rated data of the connected motor (refer to the rating plate).

Further factory setting:

- Command sources P0700 = 2 (Digital input, see Fig. 3-1)
- Setpoint source P1000 = 2 (Analog input, see Fig. 3-1)
- Motor cooling P0335 = 0
- Motor current limit P0640 = 150 %
- Min. frequency P1080 = 0 Hz
- Max. frequency P1082 = 50 Hz
- Ramp-up time P1120 = 10 s
- Ramp-down time P1121 = 10 s
- Control mode P1300 = 0

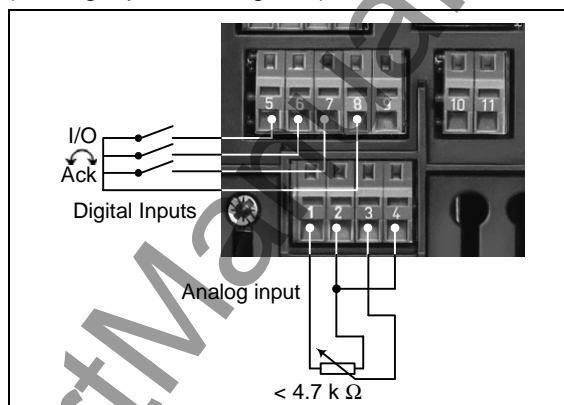

Fig. 3-1 Analog and Digital Inputs

Input/Output	Terminals	Parameter	Function
Digital input 1	5	P0701 = 1	ON / OFF1 (I/O)
Digital input 2	6	P0702 = 12	Reverse (↺)
Digital input 3	7	P0703 = 9	Fault reset (Ack)
Digital input	8	-	Power supply Digital input
Analog input	3/4	P1000 = 2	Frequency setpoint
	1/2	-	Power supply Analog input
Output relay	10/11	P0731 = 52.3	Default identification
Analog output	12/13	P0771 = 21	Output frequency

3.1 50/60 Hz DIP switch

The default motor base frequency of the MICROMASTER inverter is 50 Hz. For motors, which are designed for a base frequency of 60 Hz, the inverters can be set to this frequency via a DIP switch.

- Off position: European defaults (50 Hz, kW etc.)
- On position: North American defaults (60 Hz, hp etc.)

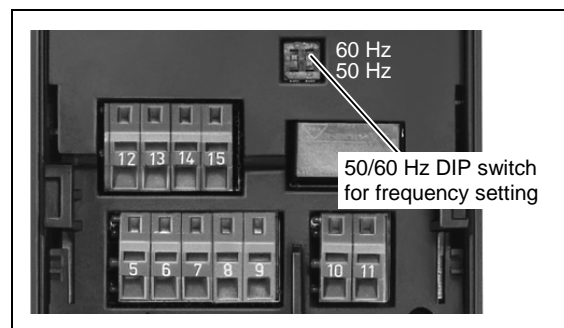

4 Communications

4.1 Establishing communications MICROMASTER 420 ↔ STARTER

The following optional components are additionally required in order to establish communications between STARTER and MICROMASTER 420:

- PC ↔ frequency inverter connecting set
- BOP if the USS standard values (refer to Section 6.2.1 "Serial Interface (USS)") are changed in the MICROMASTER 420 frequency inverter

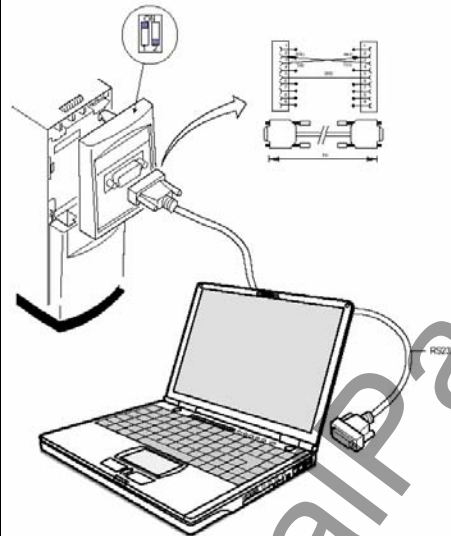
PC ↔ frequency inverter connecting set	MICROMASTER 420
	USS settings, refer to Section 6.2.1 "Serial Interface (USS)"
	STARTER
	Menu, Options --> Set PG/PC interface --> Select "PC COM-Port (USS)" --> Properties --> Interface "COM1", select a baud rate
	<p>NOTE</p> <p>The USS parameter settings in the MICROMASTER 420 frequency inverter and the settings in STARTER must match!</p>









4.2 Establishing communications between the MICROMASTER 420 ↔ AOP

- Communications between AOP and MM420 are based on the USS protocol, analog to STARTER and MM420.
- Contrary to the BOP, the appropriate communication parameters - both for the MM420 as well as for AOP - should be set if the automatic interface detection was not carried-out (refer to Table 4-1).
- Using the optional components, the AOP can be connected to the communication interfaces (refer to Table 4-1).

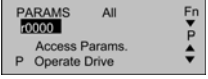
Table 4-1

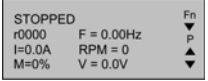
	AOP at the BOP link	AOP at the COM link
MM420 parameters - baud rate - bus address	P2010[1] -	P2010[0] P2011
AOP parameters - baud rate - bus address	P8553 -	P8553 P8552
Options - direct connection - indirect connection	No option necessary BOP/AOP door mounting kit (6SE6400-0PM00-0AA0)	Not possible AOP door mounting kit (6SE6400-0MD00-0AA0)

AOP as control unit

Parameter / Terminal		AOP on BOP link	AOP on COM link
Command source  / 	P0700	4	5
Frequency setpoint (MOP)	P1000	1	
	P1035	2032.13 (2032.D)	2036.13 (2036.D)
	P1036	2032.14 (2032.E)	2036.14 (2036.E)
			
			
		Output frequency of the MOP higher	
		Output frequency of the MOP lower	
Acknowledge fault 	P2104	2032.7	2036.7

* A fault can be acknowledged via the AOP independently of P0700 or P1000.

4.3 Bus interface (CB)

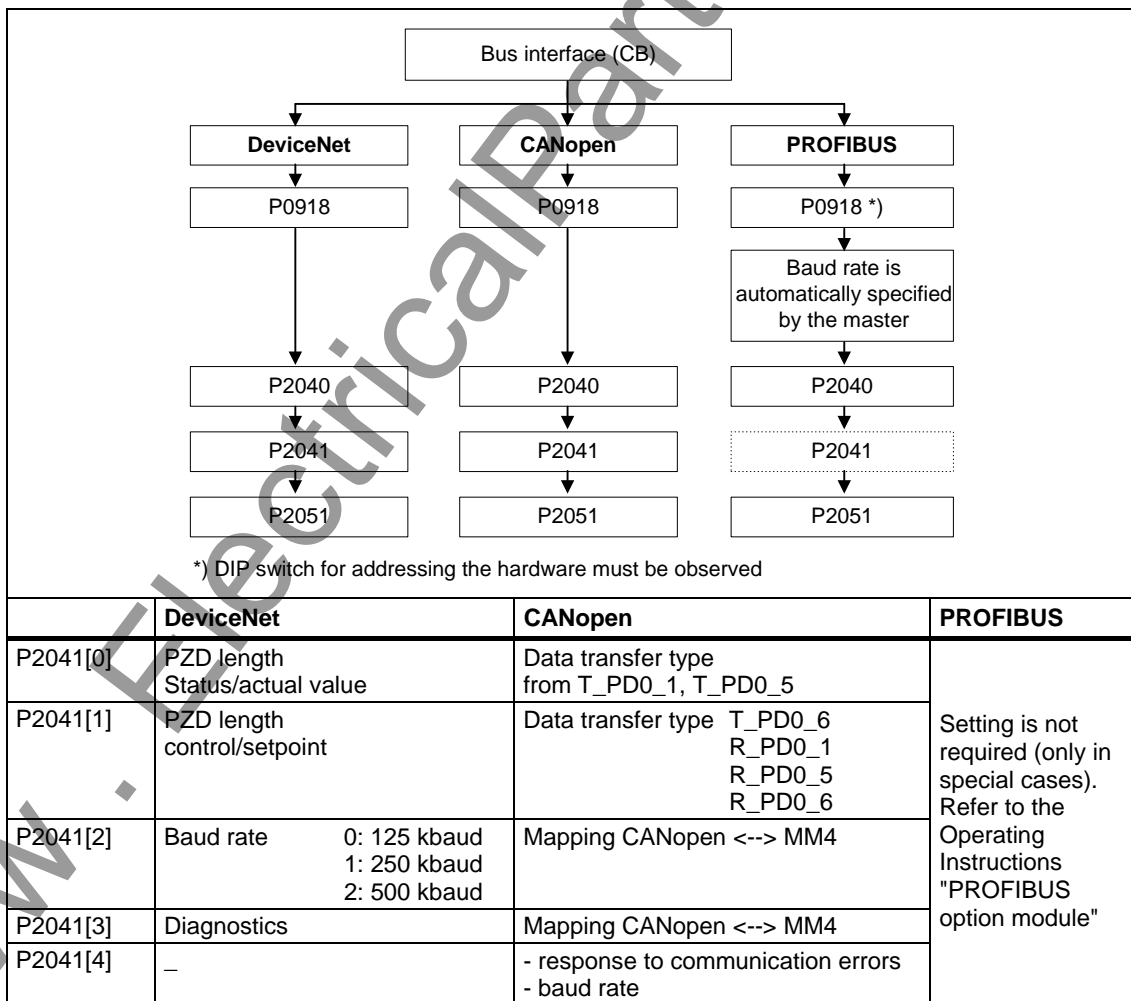

5 BOP / AOP (Option)

5.1 Buttons and their Functions



Panel/ Button	Function	Effects
	Indicates Status	The LCD displays the settings currently used by the converter.
	Start converter	Pressing the button starts the converter. This button is disabled by default. Activate the button: BOP: P0700 = 1 or P0719 = 10 ... 16 AOP: P0700 = 4 or P0719 = 40 ... 46 on BOP link P0700 = 5 or P0719 = 50 ... 56 on COM link
	Stop converter	OFF1 Pressing the button causes the motor to come to a standstill at the selected ramp down rate. Activate the button: see button "Start converter" OFF2 Pressing the button twice (or once long) causes the motor to coast to a standstill. BOP: This function is always enabled (independent of P0700 or P0719).
	Change direction	Press this button to change the direction of rotation of the motor. Reverse is indicated by a minus (-) sign or a flashing decimal point. Disabled by default. Activate the button: see button "Start converter".
	Jog motor	In the "Ready to power-on" state, when this key is pressed, the motor starts and rotates with the pre-set jog frequency. The motor stops when the button is released. Pressing this button when the motor is running has no effect.
	Functions	This button can be used to view additional information. It works by pressing and holding the button. It shows the following, starting from any parameter during operation: 1. DC link voltage (indicated by d – units V). 2. output current. (A) 3. output frequency (Hz) 4. output voltage (indicated by o – units V). 5. The value selected in P0005 (If P0005 is set to show any of the above (1 - 4) then this will not be shown again). Additional presses will toggle around the above displays. Jump Function From any parameter (rxxxx or Pxxxx) a short press of the Fn button will immediately jump to r0000, you can then change another parameter, if required. Upon returning to r0000, pressing the Fn button will return you to your starting point. Acknowledgement If alarm and fault messages are present, then these can be acknowledged by pressing key Fn.
	Access parameters	Pressing this button allows access to the parameters.
	Increase value	Pressing this button increases the displayed value.
	Decrease value	Pressing this button decreases the displayed value.
	AOP menu	Calls the AOP menu prompting (this is only available for AOP).

5.2 Changing parameters using as an example P0003 "Access level"

Step	Result on display
1 Press P to access parameters	r 0000
2 Press ▲ until P0003 is displayed	P 0003
3 Press P to access the parameter value level	1
4 Press ▲ or ▼ to the required value (example: 3)	3
5 Press P to confirm and store the value	P 0003
6 Now access level 3 is set and all level 1 to level 3 parameters are visible to the user.	

6 Commissioning

6.1 Quick commissioning

The frequency inverter is adapted to the motor using the quick commissioning function and important technological parameters are set. The quick commissioning shouldn't be carried-out if the rated motor data saved in the frequency inverter (4-pole 1LA Siemens motor, star circuit configuration \cong frequency inverter (FU)-specific) match the rating plate data.

Parameters, designated with a * offer more setting possibilities than are actually listed here. Refer to the parameter list for additional setting possibilities.

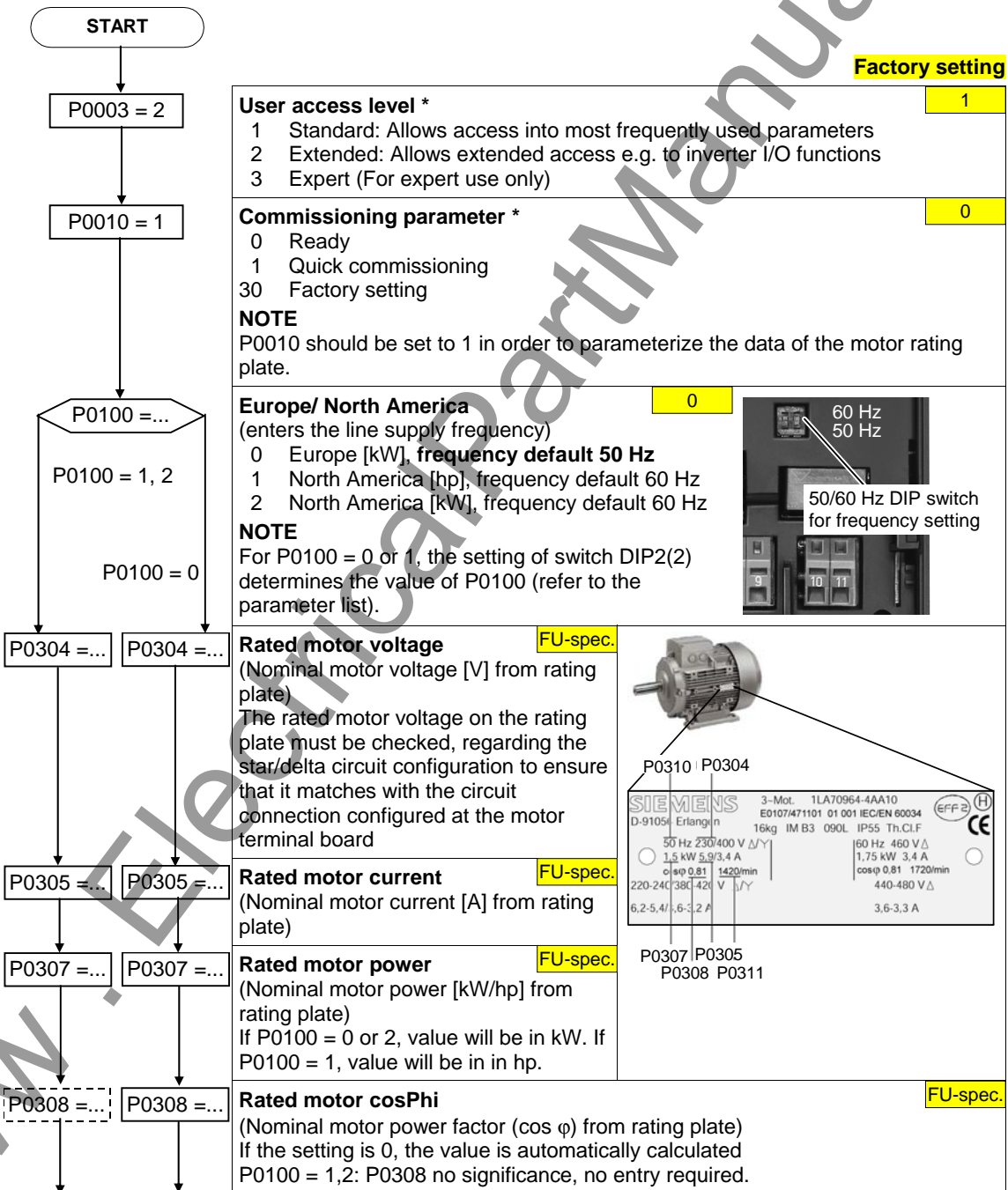

P0309 =...	P0309 =...	Rated motor efficiency (Nominal motor efficiency in [%] from rating plate) Setting 0 causes internal calculation of value. P0100 = 0: P0309 no significance, no entry required.	FU-spec.
P0310 =...		Rated motor frequency (Nominal motor frequency in [Hz] from rating plate) Pole pair number recalculated automatically if parameter is changed.	50.00 Hz
P0311 =...		Rated motor speed (Nominal motor speed in [rpm] from rating plate) Setting 0 causes internal calculation of value. NOTE For slip compensation, the input is absolutely necessary.	FU-spec.
P0335 =...		Motor cooling (Selects motor cooling system used) 0 Self-cooled: Using shaft mounted fan attached to motor 1 Force-cooled: Using separately powered cooling fan	0
P0640 =...		Motor overload factor (Motor overload factor in [%] relative to P0305) This defines the limit of the maximum output current as a % of the rated motor current (P0305).	150 %
P0700 =...		Selection of command source 0 Factory default setting 1 BOP (keypad) 2 Terminal 4 USS on BOP link 5 USS on COM link 6 CB on COM link	2
P1000 =...		Selection of frequency setpoint 1 MOP setpoint 2 Analog setpoint 3 Fixed frequency 4 USS on BOP link 5 USS on COM link 6 CB on COM link	2
P1080 =...		Min. frequency (enters the minimum motor frequency in Hz) Sets minimum motor frequency at which motor will run irrespective of frequency setpoint. The value set here is valid for both clockwise and anticlockwise rotation.	0.00 Hz
P1082 =...		Max. frequency (enters the maximum motor frequency in Hz) Sets maximum motor frequency at which motor will run irrespective of the frequency setpoint. The value set here is valid for both clockwise and anticlockwise rotation.	50.00 Hz
P1120 =...		Ramp-up time (enters the ramp-up time in s) Time taken for motor to accelerate from standstill up to maximum motor frequency (P1082) when no rounding is used.	10.00 s
P1121 =...		Ramp-down time (enters the deceleration time in s) Time taken for motor to decelerate from maximum motor frequency (P1082) down to standstill when no rounding is used	10.00 s
P1135 =...		OFF3 ramp-down time (enters the fast stop ramp-down time in s) Defines ramp-down time from maximum frequency to standstill for OFF3 command.	5.00 s

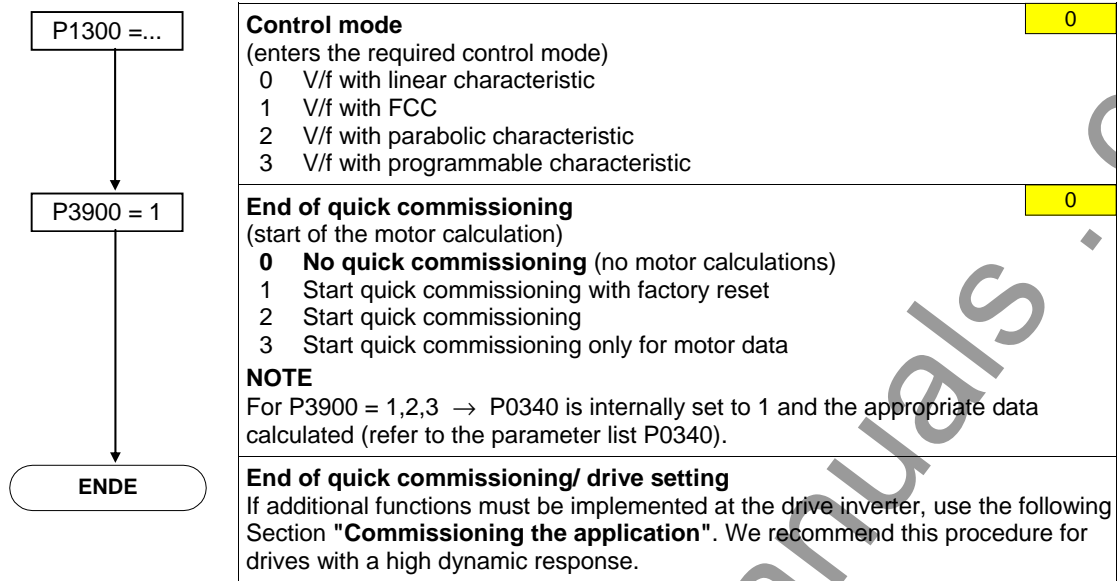

6.2 Commissioning the application

An application is commissioned to adapt/optimize the frequency inverter - motor combination to the particular application. The frequency inverter offers numerous functions - but not all of these are required for the particular application. These functions can be skipped when commissioning the application. A large proportion of the possible functions are described here; refer to the parameter list for additional functions.

Parameters, designated with a * offer more setting possibilities than are actually listed here. Refer to the parameter list for additional setting possibilities.

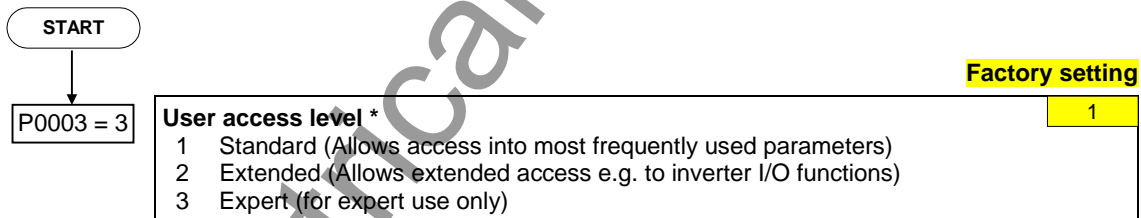

6.2.1 Serial Interface (USS)

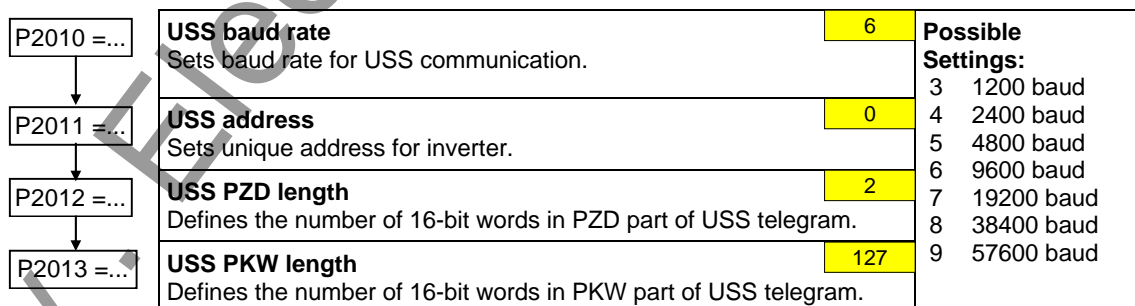

6.2.2 Selection of command source

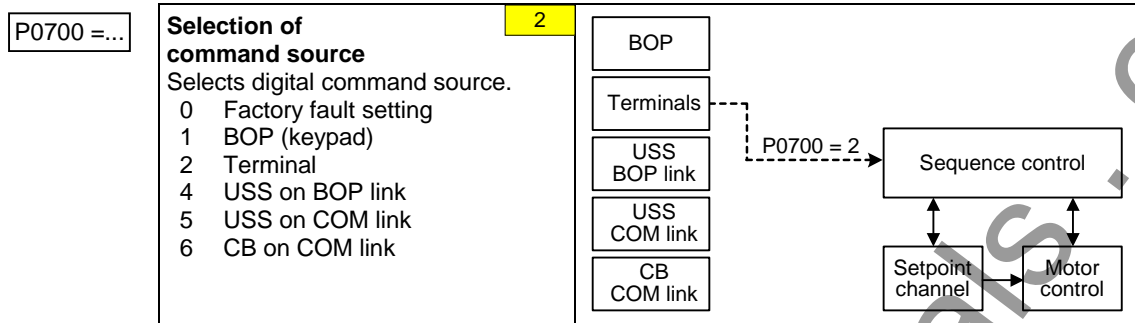

6.2.3 Digital input (DIN)

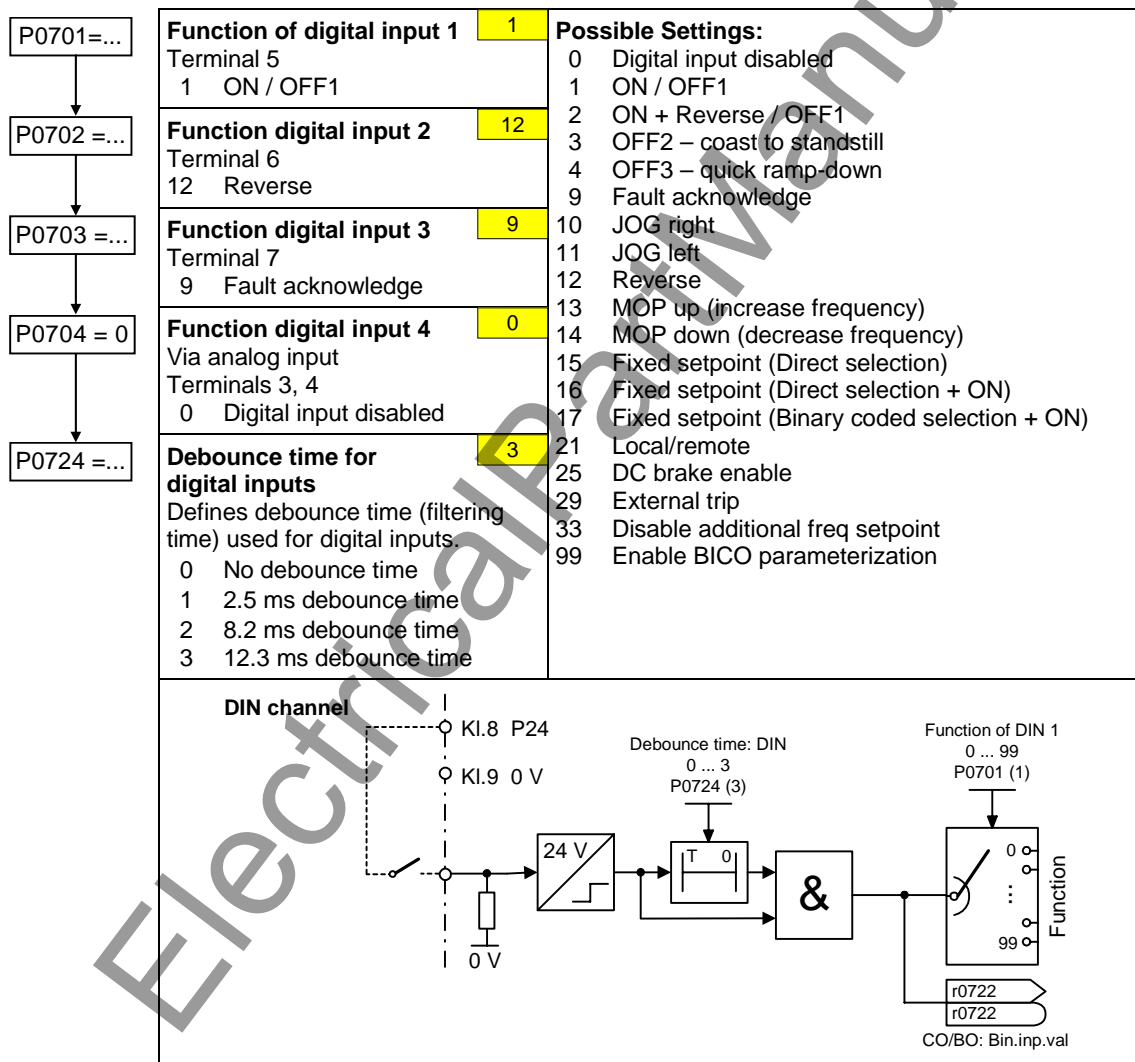

6.2.4 Digital output (DOUT)

P0731 =...

↓

P0748 = 0

BI: Function of digital output 1* Defines source of digital output 1.	52.3	Common Settings:	
		52.0 Drive ready	0 Closed
		52.1 Drive ready to run	0 Closed
		52.2 Drive running	0 Closed
		52.3 Drive fault active	0 Closed
		52.4 OFF2 active	1 Closed
		52.5 OFF3 active	1 Closed
		52.6 Switch on inhibit active	0 Closed
		52.7 Drive warning active	0 Closed
Invert digital output			
Defines high and low states of relay for a given function.	0		

DOUT channel

6.2.5 Selection of frequency setpoint

P1000 =...

Selection of frequency setpoint	2
<ul style="list-style-type: none"> 0 No main setpoint 1 MOP setpoint 2 Analog setpoint 3 Fixed frequency 4 USS on BOP link 5 USS on COM link 6 CB on COM link 	

6.2.7 Analog output (DAC)

<p>P0771 =...</p> <p>↓</p> <p>P0773 =...</p> <p>↓</p> <p>P0777 =...</p> <p>↓</p> <p>P0778 =...</p> <p>↓</p> <p>P0779 =...</p> <p>↓</p> <p>P0780 =...</p> <p>↓</p> <p>P0781 =...</p>	<p>CI: DAC 21</p> <p>Defines function of the 0 - 20 mA analog output.</p> <hr/> <p>Smooth time DAC 2 ms</p> <p>Defines smoothing time [ms] for analog output signal. This parameter enables smoothing for DAC using a PT1 filter.</p> <hr/> <p>Value x1 of DAC scaling 0.0 %</p> <hr/> <p>Value y1 of DAC scaling 0</p> <hr/> <p>Value x2 of DAC scaling 100.0 %</p> <hr/> <p>Value y2 of DAC scaling 20</p> <hr/> <p>Width of DAC deadband 0</p> <p>Sets width of deadband in [mA] for analog output.</p>	
<p>DAC channel</p>		

6.2.10 JOG

P1058 =...	JOG frequency right Frequency in Hz when the motor is being jogged in the clockwise direction of rotation.	5.00 Hz	
P1059 =...	JOG frequency left Frequency in Hz when the motor is being jogged in the counter-clockwise direction of rotation.	5.00 Hz	
P1060 =...	JOG ramp-up time Ramp-up time in s from 0 to the maximum frequency (P1082). The JOG ramp-up is limited by P1058 or P1059.	10.00 s	
P1061 =...	JOG ramp-down time Ramp-down time in s from the maximum frequency (P1082) to 0.	10.00 s	

6.2.11 Ramp-function generator (HLG)

P1091 =...	Skip frequency 1 (entered in Hz) Defines skip frequency 1 which avoids effects of mechanical resonance and suppresses frequencies within +/- P1101 (skip frequency bandwidth).	0.00 Hz	
P1091 =...	Skip frequency 2	0.00 Hz	
P1091 =...	Skip frequency 3	0.00 Hz	
P1091 =...	Skip frequency 4	0.00 Hz	
P1101 =...	Skip frequency bandwidth (entered in Hz)	2.00 Hz	
P1120 =...	Ramp-up time (enters the accelerating time in s)	10.00 s	
P1121 =...	Ramp-down time (enters the deceleration time in s)	10.00 s	
P1130 =...	Ramp-up initial rounding time (entered in s)	0.00 s	
P1131 =...	Ramp-up final rounding time (entered in s)	0.00 s	<p>The rounding times are recommended as abrupt responses can be avoided therefore reducing stress and damage to the mechanical system.</p> <p>The ramp-up and ramp-down times are extended by the component of the rounding ramps.</p>
P1132 =...	Ramp-down initial rounding time (entered in s)	0.00 s	
P1133 =...	Ramp-down final rounding time (entered in s)	0.00 s	
P1134 =...	Rounding type 0 Continuous smoothing 1 Discontinuous smoothing	0	
P1135 =...	OFF3 ramp-down time Defines ramp-down time from maximum frequency to standstill for OFF3 command.	5.00 s	

6.2.12 Reference/limit frequencies

P1080 =...	<p>Min. frequency (entered in Hz) 0.00 Hz</p> <p>Sets minimum motor frequency [Hz] at which motor will run irrespective of frequency setpoint. If the setpoint falls below the value of P1080, then the output frequency is set to P1080 taking into account the sign.</p>
P1082 =...	<p>Max. frequency (entered in Hz) 50.00 Hz</p> <p>Sets maximum motor frequency [Hz] at which motor will run irrespective of the frequency setpoint. If the setpoint exceeds the value P1082, then the output frequency is limited. The value set here is valid for both clockwise and anticlockwise rotation.</p>
P2000 =...	<p>Reference frequency (entered in Hz) 50.00 Hz</p> <p>The reference frequency in Hertz corresponds to a value of 100 %. This setting should be changed if a maximum frequency of higher than 50 Hz is required. It is automatically changed to 60 Hz if the standard 60 Hz frequency was selected using the DIP50/60 switch or P0100.</p> <p>NOTE This reference frequency effects the setpoint frequency as both the analog setpoints (100 % $\hat{=}$ P2000) as well as the frequency setpoints via USS (4000H $\hat{=}$ P2000) refer to this value.</p>

6.2.13 Motor control (V/f)

P1300 =...	<p>Control mode 0</p> <p>The control type is selected using this parameter. For the "V/f characteristic" control type, the ratio between the frequency inverter output voltage and the frequency inverter output frequency is defined.</p> <ul style="list-style-type: none"> 0 V/f with linear 1 V/f with FCC 2 V/f with parabolic characteristic 3 V/f with programmable characteristic (\rightarrow P1320 – P1325)
P1310 =...	<p>Continuous boost (entered in %) 50.00 %</p> <p>Voltage boost as a % relative to P0305 (rated motor current) and P0350 (stator resistance). P1310 is valid for all V/f versions (refer to P1300). At low output frequencies, the effective resistance values of the winding can no longer be neglected in order to maintain the motor flux.</p>
P1311 =...	<p>Acceleration boost (entered in %) 0.0 %</p> <p>Voltage boost for accelerating/braking as a % relative to P0305 and P0350. P1311 only results in a voltage boost when ramping-up/ramp-down and generates an additional torque for accelerating/braking. Contrary to parameter P1312, that is only active for the 1st acceleration operation after the ON command, P1311 is effective each time that the drive accelerates or brakes.</p>

P1312 =...	<p>Starting boost (entered in %) 0.0 %</p> <p>Voltage boost when starting (after an ON command) when using the linear or square-law V/f characteristic as a % relative to P0305 (rated motor current) or P0350 (stator resistance). The voltage boost remains active until</p> <ol style="list-style-type: none"> 1) the setpoint is reached for the first time and 2) the setpoint is reduced to a value that is less than the instantaneous ramp-function generator output.
P1320 =...	<p>Programmable V/f freq. coord. 1 0.0 Hz</p> <p>Sets V/f coordinates (P1320/1321 to P1324/1325) to define V/f characteristic.</p>
P1321 =...	<p>Programmable V/f volt. coord. 1 0.0 Hz</p>
P1322 =...	<p>Programmable V/f freq. coord. 2 0.0 Hz</p>
P1323 =...	<p>Programmable V/f volt. coord. 2 0.0 Hz</p>
P1324 =...	<p>Programmable V/f freq. coord. 3 0.0 Hz</p>
P1325 =...	<p>Programmable V/f volt. coord. 3 0.0 Hz</p>
P1335 =...	<p>Slip compensation (entered in %) 0.0 %</p> <p>Dynamically adjusts output frequency of inverter so that motor speed is kept constant independent of motor load.</p>
P1338 =...	<p>Resonance damping gain V/f 0.00</p> <p>Defines resonance damping gain for V/f.</p>

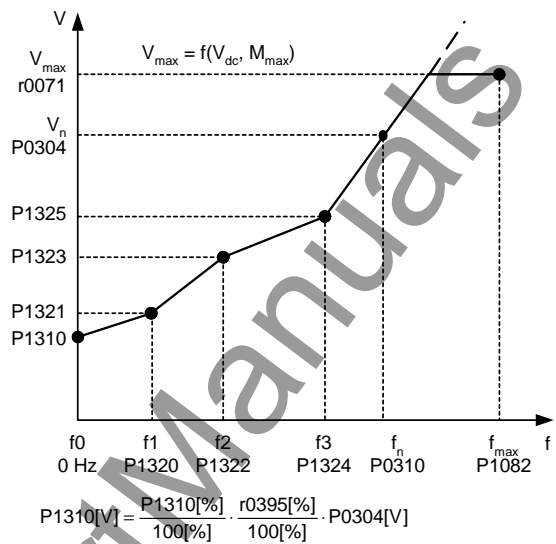

www.ElectricalPartManuals.com

6.2.14 Inverter/motor protection

P0290 =...	Inverter overload reaction Selects reaction of inverter to an internal over-temperature. 0 Reduce output frequency 1 Trip (F0004) 2 Reduce pulse frequency and output frequency 3 Reduce pulse frequency then trip (F0004)	0
P0292 =...	Inverter temperature warning Defines the temperature difference (in °C) between the Overtemperature trip threshold and the warning threshold of the inverter. The trip threshold is stored internally by the inverter and cannot be changed by the user.	15 °C
P0335 =...	Motor cooling (enters the motor cooling system) 0 Self-cooled: Using shaft mounted fan attached to motor 1 Force-cooled: Using separately powered cooling fan	0
P0610 =...	Motor I²t reaction Defines reaction when motor I ² t reaches warning threshold. 0 Warning, no reaction, no trip 1 Warning, I _{max} reduction, trip F0011 2 Warning, no reaction, trip (F0011)	2
P0611 =...	Motor I²t time constant (entered in s) The time until the thermal limit of a motor is reached, is calculated via the thermal time constant. A higher value increases the time at which the motor thermal limit is reached. The value of P0611 is estimated according to the motor data during quick commissioning or is calculated using P0340 (Calculating of the motor parameters). When the calculation of motor parameters during quick commissioning is complete the stored value can be replaced by the value given by the motor manufacturer	100 s
P0614 =...	Motor I²t warning level (entered in %) Defines the value at which alarm A0511 (motor overtemperature) is generated.	100.0 %
P0640 =...	Motor overload factor [%] Defines motor overload current limit in [%] relative to P0305 (rated motor current). Limited to maximum inverter current or to 400 % of rated motor current (P0305), whichever is the lower.	150.0 %

6.2.15 Inverter-specific Functions

6.2.15.1 Flying start

P1200 =...	<p>Flying start 0</p> <p>Starts inverter onto a spinning motor by rapidly changing the output frequency of the inverter until the actual motor speed has been found.</p> <ul style="list-style-type: none"> 0 Flying start disabled 1 Flying start is always active, start in direction of setpoint 2 Flying start is active if power on, fault, OFF2, start in direction of setpoint 3 Flying start is active if fault, OFF2, start in direction of setpoint 4 Flying start is always active, only in direction of setpoint 5 Flying start is active if power on, fault, OFF2, only in direction of setpoint 6 Flying start is active if fault, OFF2, only in direction of setpoint
P1202 =...	<p>Motor-current: Flying start (entered in %) 100 %</p> <p>Defines search current used for flying start.</p>
P1203 =...	<p>Search rate: Flying start (entered in %) 100 %</p> <p>Sets factor by which the output frequency changes during flying start to synchronize with turning motor.</p>

6.2.15.2 Automatic restart

P1210 =...	<p>Automatic restart 0</p> <p>Configures automatic restart function.</p> <ul style="list-style-type: none"> 0 Disabled 1 Trip reset after power on 2 Restart after mains blackout 3 Restart after mains brownout or fault 4 Restart after mains brownout 5 Restart after mains blackout and fault 6 Restart after mains brown/blackout or fault
------------	--

6.2.15.3 Holding brake

P1215 =...	Holding brake enable 0 Enables/disables holding brake function (MHB). 0 Motor holding brake disabled 1 Motor holding brake enabled NOTE The following must apply when controlling the brake relay via a digital output: P0731 = 52.12 (= 52.C) (refer to Section 6.2.4 "Digital ").
P1216 =...	Holding brake release delay (entered in s) 1.0 s Defines the time interval during which the frequency inverter runs with the min. frequency P1080 after magnetizing, before the ramp-up starts.
P1217 =...	Holding time after ramp-down (entered in s) 1.0 s Defines time for which inverter runs at minimum frequency (P1080) after ramping down.

6.2.15.4 DC braking

P1232 =...	DC braking current (entered in %) 100 % Defines level of DC current in [%] relative to rated motor current (P0305).
P1233 =...	Duration of DC braking (entered in s) 0 s Defines duration for which DC injection braking is to be active following an OFF1 or OFF3 command.

6.2.15.5 Compound braking

P1236 =...	Compound braking current (entered in %) 0 % Defines DC level superimposed on AC waveform after exceeding DC-link voltage threshold of compound braking. The value is entered in [%] relative to rated motor current (P0305). (see also 6.2.15.6). If P1254 = 0 : Compound braking switch-on level $U_{DC_Comp} = 1.13 \cdot \sqrt{2} \cdot V_{mains} = 1.13 \cdot \sqrt{2} \cdot P0210$ otherwise : Compound braking switch-on level $U_{DC_Comp} = 0.98 \cdot r1242$
------------	--

6.2.15.6 Vdc controller

P1240 =...	Configuration of Vdc controller 1 Enables / disables Vdc controller. 0 Vdc controller disabled 1 Vdc-max controller enabled	<p>The diagram consists of three vertically aligned plots sharing a common time axis (t). 1. Top plot: V_{DC} vs t. Shows a step increase to a level labeled r1242, followed by a step decrease. 2. Middle plot: V_{DC,max}-controller active vs t. Shows a pulse labeled A0911 that occurs during the step increase and the initial part of the step decrease. 3. Bottom plot: f vs t. Shows a ramp down from a higher frequency to a lower frequency. The starting frequency is labeled f_{set} and the ending frequency is labeled f_{fact}. A dashed line indicates the ramp profile.</p>
P1254 =...	Auto detect Vdc switch-on levels 1 Enables/disables auto-detection of switch-on levels for Vdc control functionalities. 0 Disabled 1 Enabled	

6.2.15.7 PID controller

P2200 =...	BI: Enable PID controller PID mode Allows user to enable/disable the PID controller. Setting to 1 enables the PID controller. Setting 1 automatically disables normal ramp times set in P1120 and P1121 and the normal frequency setpoints.	0.0
P2253 =...	CI: PID setpoint Defines setpoint source for PID setpoint input.	0.0
P2254 =...	CI: PID trim source Selects trim source for PID setpoint. This signal is multiplied by the trim gain and added to the PID setpoint.	0.0
P2257 =...	Ramp-up time for PID setpoint Sets the ramp-up time for the PID setpoint.	1.00 s
P2258 =...	Ramp-down time for PID setpoint Sets ramp-down time for PID setpoint.	1.00 s
P2264 =...	CI: PID feedback Selects the source of the PID feedback signal.	755.0
P2267 =...	Max. value for PID feedback Sets the upper limit for the value of the feedback signal in [%].	100.00 %
P2268 =...	Min. value for PID feedback Sets lower limit for value of feedback signal in [%].	0.00 %
P2280 =...	PID proportional gain Allows user to set proportional gain for PID controller.	3.000
P2285 =...	PID integral time Sets integral time constant for PID controller.	0.000 s
P2291 =...	PID output upper limit Sets upper limit for PID controller output in [%].	100.00 %
P2292 =...	PID output lower limit Sets lower limit for the PID controller output in [%].	0.00 %

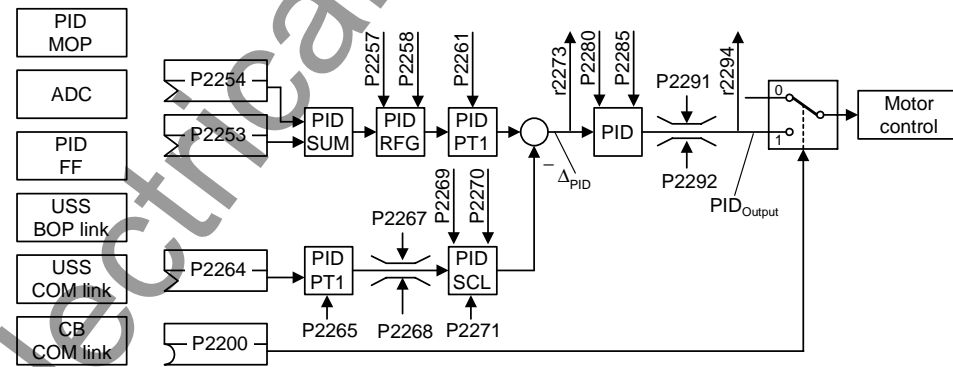

Example:

Parameter	Parameter text	Example
P2200	BI: Enable PID controller	P2200 = 1.0 PID controller active
P2253	CI: PID setpoint	P2253 = 2224 PID-FF1
P2264	CI: PID feedback	P2264 = 755 ADC
P2267	Max. PID feedback	P2267 Adapt to the application
P2268	Min. PID feedback	P2268 Adapt to the application
P2280	PID proportional gain	P2280 Determined by optimizing
P2285	PID integral time	P2285 Determined by optimizing
P2291	PID output upper limit	P2291 Adapt to the application
P2292	PID output lower limit	P2292 Adapt to the application

6.3 Series commissioning

An existing parameter set can be transferred to a MICROMASTER 420 frequency inverter using STARTER or DriveMonitor (refer to Section 4.1 "Establishing communications MICROMASTER 420 ↔ STARTER").

Typical applications for series commissioning include:

1. If several drives are to be commissioned that have the same configuration and same functions. A quick / application commissioning (first commissioning) must be carried-out for the first drive. Its parameter values are then transferred to the other drives.
2. When replacing MICROMASTER 420 frequency inverters.

6.4 Parameter reset of factory setting

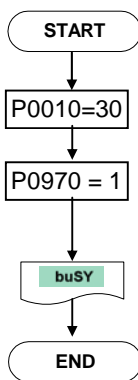

Commissioning parameter	0
30 Factory setting	
Factory reset	0
0 disabled	
1 Parameter reset	

The drive inverter carries-out a parameter reset (duration, approx. 10 s) and then automatically exits the reset menu and sets:

P0970 = 0 : disabled
P0010 = 0 : ready

7 Displays and messages

7.1 LED status display

LED State	Meaning
●	Mains not present
☀	Ready to run
● ☀	Inverter fault other than the ones listed below
☀ ●	Inverter running
● ☀ ●	Fault overcurrent
● ☀ ● ●	Fault overvoltage
● ☀ ● ● ●	Fault motor overtemperature
☀	Fault inverter temperature
● ☀ ●	Warning current limit both LEDs twinkling same time
● ☀ ● ●	Other warnings both LEDs twinkling alternatively
● ☀ ● ● ●	Undervoltage trip / undervoltage warning
● ☀ ● ● ● ●	Drive is not in ready state
● ☀ ● ● ● ● ●	ROM failure both LEDs flashing same time
● ☀ ● ● ● ● ● ●	RAM failure both LEDs flashing alternatively

7.2 Fault messages and Alarm messages

Fault	Significance
F0001	Overcurrent
F0002	Overvoltage
F0003	Undervoltage
F0004	Inverter Overtemperature
F0005	Inverter I ² t
F0011	Motor Overtemperature I ² t
F0041	Stator resistance measurement failure
F0051	Parameter EEPROM Fault
F0052	Powerstack Fault
F0060	Asic Timeout
F0070	Communications board setpoint error
F0071	No Data for USS (RS232 link) during Telegram Off Time
F0072	No Data from USS (RS485 link) during Telegram Off Time
F0080	Analogue input - lost input signal
F0085	External Fault
F0101	Stack Overflow
F0221	PI Feedback below minimum value
F0222	PI Feedback above maximum value
F0450	BIST Tests Failure (Service mode only)

Alarms	Significance
A0501	Current Limit
A0502	Overvoltage limit
A0503	Undervoltage Limit
A0504	Inverter Overtemperature
A0505	Inverter I ² t
A0506	Inverter Duty Cycle
A0511	Motor Overtemperature I ² t
A0541	Motor Data Identification Active
A0600	RTOS Overrun Warning
A0700 - A0709	CB warning
A0710	CB communication error
A0711	CB configuration error
A0910	Vdc-max controller de-activated
A0911	Vdc-max controller active
A0920	ADC parameters not set properly
A0921	DAC parameters not set properly
A0922	No load applied to inverter
A0923	Both JOG Left and JOG Right are requested

Information about MICROMASTER 420 is also available from:

Regional Contacts

Please get in touch with your contact for Technical Support in your Region for questions about services, prices and conditions of Technical Support.

Central Technical Support

The competent consulting service for technical issues with a broad range of requirements-based services around our products and systems.

Europe / Africa

Tel: +49 (0) 180 5050 222
Fax: +49 (0) 180 5050 223
Email: adsupport@siemens.com

America

Tel: +1 423 262 2522
Fax: +1 423 262 2589
Email: simatic.hotline@sea.siemens.com

Asia / Pacific

Tel: +86 1064 757 575
Fax: +86 1064 747 474
Email: adsupport.asia@siemens.com

Online Service & Support

The comprehensive, generally available information system over the Internet, from product support to service & support to the support tools in the shop.

<http://www.siemens.com/automation/service&support>

Internet Address

Customers can access technical and general information under the following address:

<http://www.siemens.com/micromaster>