

SIEMENS

SIMOVERT MASTER DRIVES
Vector Control (VC)

Operating Instructions
Part 2

www.ElectricalPartManuals.com

Overview of the MASTER DRIVES Operating Instructions:

Operating Instructions	consists of	
	Part 1	Part 2
6SE708_-_AD10	6SE708_-_AD70	6SE708_-_XX10
6SE708_-_AD20	6SE708_-_AD70	6SE708_-_XX20
6SE708_-_AD30	6SE708_-_AD70	6SE708_-_XX30
6SE708_-_BD10	6SE708_-_BD70	6SE708_-_XX10
6SE708_-_BD20	6SE708_-_BD70	6SE708_-_XX20
6SE708_-_BD30	6SE708_-_BD70	6SE708_-_XX30
6SE708_-_AH10	6SE708_-_AH70	6SE708_-_XX10
6SE708_-_AH20	6SE708_-_AH70	6SE708_-_XX20
6SE708_-_AH30	6SE708_-_AH70	6SE708_-_XX30
6SE708_-_BH10	6SE708_-_BH70	6SE708_-_XX10
6SE708_-_BH20	6SE708_-_BH70	6SE708_-_XX20
6SE708_-_BH30	6SE708_-_BH70	6SE708_-_XX30
6SE708_-_BM20	6SE708_-_BM70	6SE708_-_XX20

▶ You will receive Parts 1 and 2 of the Operating Instructions when you use this Order No. Parts 1 and 2 can be individually ordered by specifying the particular Order No.
 __ stands for the language code, e.g. 0-0 for German Editions.

The following foreign language Editions of these Operating Instructions are available:

Language	English	French	Spanish	Italian
Language code	7-6	7-7	7-8	7-2

These Operating Instructions are valid for software release V1.3.

The reproduction, transmission or use of this document or its contents is not permitted without express written authority. Offenders will be liable for damages. All rights, including rights created by patent grant or registration of a utility model or design, are reserved.

We have checked the contents of this document to ensure that they coincide with the described hardware and software. However, differences cannot be completely excluded, so that we do not accept any guarantee for complete conformance. However, the information in this document is regularly checked and necessary corrections will be included in subsequent editions. We are grateful for any recommendations for improvement.

SIMOVERT® Registered Trade Mark

Contents

0	Definitions.....	7
	Safety and operating instructions for drive converters	9
1	Control terminal strip and serial interface.....	1-1
1.1	Connectors for the control terminal strip.....	1-1
1.1.1	Connecting-up the control cables.....	1-2
1.2	Terminal connection	1-3
1.2.1	Connecting-up the parameterizing unit (PMU)	1-5
1.3	Measures to maintain the radio interference suppression regulations	1-6
2	Operator control.....	2-1
2.1	Operator control elements.....	2-1
2.2	Displays 	2-2
2.3	Structure	2-3
3	General explanation of the terminology and functional scope of the unit.....	3-1
3.1	Converter open-loop/closed-loop control versions	3-1
3.2	Process data.....	3-1
3.3	Indexed parameters	3-2
3.4	Data sets	3-2
4	Start-up.....	4-1
4.1	Capacitor forming	4-1
4.2	First start-up	4-2
4.2.1	Parameterization „Standard application“	4-3
4.2.2	Parameterization „Expert application“	4-4
4.3	Drive start-up when the drive converter is controlled through an external main contactor.....	4-8
4.4	Drive start-up after enabling additional software functions or hardware options.....	4-10
4.5	Simple application examples for connecting process data with connection assignment.....	4-11
4.5.1	Factory setting.....	4-11
4.5.2	Manual/automatic operation (Basic/reserve changeover)	4-12

5	Process data	5-1
5.1	Control word (control word 1 and control word 2).....	5-1
5.1.1	Control word display using the 7-segment display on the PMU	5-1
5.1.2	Control word 1 (Visualization parameter r550 or r967).....	5-2
5.1.3	Control word 2 (Visualization parameter r551)	5-3
5.1.4	Selecting the source for control words 1 and 2	5-4
5.1.5	Significance of control word- (1 and 2) commands	5-6
5.2	Status word.....	5-13
5.2.1	Status word 1 (visualization parameter r552 or r968).....	5-14
5.2.2	Status word 2 (visualization parameter r553)	5-15
5.2.3	Significance of the status word messages.....	5-16
5.3	Setpoints.....	5-22
5.3.1	Overview of the setpoints	5-23
5.3.2	Selecting the possible setpoint sources.....	5-24
5.4	Actual values	5-25
6	Interfaces.....	6-1
6.1	Binary inputs.....	6-1
6.2	Binary outputs.....	6-2
6.3	Analog inputs.....	6-3
6.3.1	Analog input as setpoint input.....	6-3
6.3.2	Analog input as speed actual value input.....	6-6
6.4	Analog outputs.....	6-8
6.5	Serial interfaces.....	6-10
6.5.1	Basic converter interfaces SST1 and SST2	6-10
6.5.2	Dual port RAM (DPR for SCB, TSY, CB, TB).....	6-11
6.6	Ramp-function generator (RFG) and limiting stage in front of the ramp-function generator	6-12
6.6.1	Ramp-function generator, RFG	6-12
6.6.2	Limit value stage in front of the ramp-function generator	6-15
7	Open-loop and closed-loop control types	7-1
7.1	V/f characteristic.....	7-1
7.2	Vector control types.....	7-3

8	Start-up functions	8-1
8.1	Function selection (P052).....	8-1
8.1.1	Factory setting (P052 = 1)	8-1
8.1.2	Initialization (MLFB input) (P052 = 2)	8-2
8.1.2.1	Download (P052 = 3).....	8-5
8.1.3	Hardware configuration (P052 = 4)	8-5
8.1.4	Drive setting (P052 = 5).....	8-7
8.1.5	Automatic parameterization (P052 = 6).....	8-7
8.1.6	Motor identification at standstill (P052 = 7).....	8-9
8.1.6.1	Complete motor identification (P052 = 8)	8-11
8.1.7	No-load measurement (P052 = 9)	8-13
8.1.8	n/f controller optimization (P052 = 10).....	8-14
8.1.9	Self-test (P052 = 11)	8-15
8.1.10	Tachometer test (P052 = 12).....	8-16
9	Functions (software).....	9-1
9.1	WEA (automatic restart)	9-1
9.2	KIP (Kinetic buffering).....	9-3
9.3	Flexible response	9-4
9.4	Vdmax closed-loop control	9-7
9.5	Setting the short-time overload capability.....	9-8
9.6	DC current brake	9-9
9.7	Restart-on-the-fly.....	9-10
9.8	Technology controller	9-13
9.9	Tracer	9-17
9.10	Temperature adaption.....	9-19
10	Function diagrams.....	10-1

11	Parameter list.....	11-1
11.1	General Observation Parameters.....	11-2
11.2	General Parameters.....	11-4
11.3	Drive Data.....	11-7
11.4	Hardware Configuration.....	11-8
11.5	Motor Data.....	11-9
11.6	Control.....	11-12
11.7	Functions.....	11-36
11.8	Setpoint Channel.....	11-48
11.9	Control and Status Word.....	11-61
11.10	Analog Input/Output.....	11-73
11.11	Communications.....	11-76
11.12	Diagnosis.....	11-80
11.13	Modulator.....	11-85
11.14	Factory Parameters.....	11-87
11.15	Special Parameters.....	11-87
11.16	Profile Parameters.....	11-88
12	Fault and alarm messages.....	12-1
12.1	Fault messages.....	12-1
12.2	Alarm messages.....	12-10
13	Logbook.....	13-1
14	Index and Abbreviations.....	14-1
14.1	Index.....	14-1
14.2	List of abbreviations.....	14-3

Definitions

- **QUALIFIED PERSONAL**

For the purpose of these instructions and product labels, a "Qualified person" is someone who is familiar with the installation, mounting, start-up and operation of the equipment and the hazards involved. He or she must have the following qualifications:

1. Trained and authorized to energize, de-energize, clear, ground and tag circuits and equipment in accordance with established safety procedures.
2. Trained in the proper care and use of protective equipment in accordance with established safety procedures.
3. Trained in rendering first aid.

- **DANGER**

For the purpose of these instructions and product labels, "Danger" indicates death, severe personal injury or substantial property damage will result if proper precautions are not taken.

- **WARNING**

For the purpose of these instructions and product labels, "Warning" indicates death, severe personal injury or property damage can result if proper precautions are not taken.

- **CAUTION**

For the purpose of these instructions and product labels, "Caution" indicates that minor personal injury or material damage can result if proper precautions are not taken.

- **NOTE**

For the purpose of these instructions, "Note" indicates information about the product or the respective part of the Instruction Manual which is essential to highlight.

NOTE

These instructions do not purport to cover all details or variations in equipment, nor to provide for every possible contingency to be met in connection with installation, operation or maintenance.

Should further information be desired or should particular problems arise which are not covered sufficiently for the purchaser's purposes, the matter should be referred to the local Siemens sales office.

The contents of this Instruction Manual shall not become part of or modify any prior or existing agreement, commitment or relationship. The sales contract contains the entire obligation of Siemens. The warranty contained in the contract between the parties is the sole warranty of Siemens. Any statements contained herein do not create new warranties or modify the existing warranty.

	<p>CAUTION</p> <p>Components which can be destroyed by electrostatic discharge (ESD)</p>
---	--

The converters contain components which can be destroyed by electrostatic discharge. These components can be easily destroyed if not carefully handled. If you have to handle electronic boards please observe the following:

- ◆ Electronic boards should only be touched when absolutely necessary.
- ◆ The human body must be electrically discharged before touching an electronic board
- ◆ Boards must not come into contact with highly insulating materials - e.g. plastic foils, insulated desktops, articles of clothing manufactured from man-made fibers
- ◆ Boards must only be placed on conductive surfaces
- ◆ When soldering, the soldering iron tip must be grounded
- ◆ Boards and components should only be stored and transported in conductive packaging (e.g. metalized plastic boxes, metal containers)
- ◆ If the packing material is not conductive, the boards must be wrapped with a conductive packaging material, e.g. conductive foam rubber or household aluminum foil.

The necessary ECB protective measures are clearly shown in the following diagram:

- | | | | |
|-----|--------------------------|-----|---------------------------|
| a = | Conductive floor surface | d = | ESD overall |
| b = | ESD table | e = | ESD chain |
| c = | ESD shoes | f = | Cubicle ground connection |

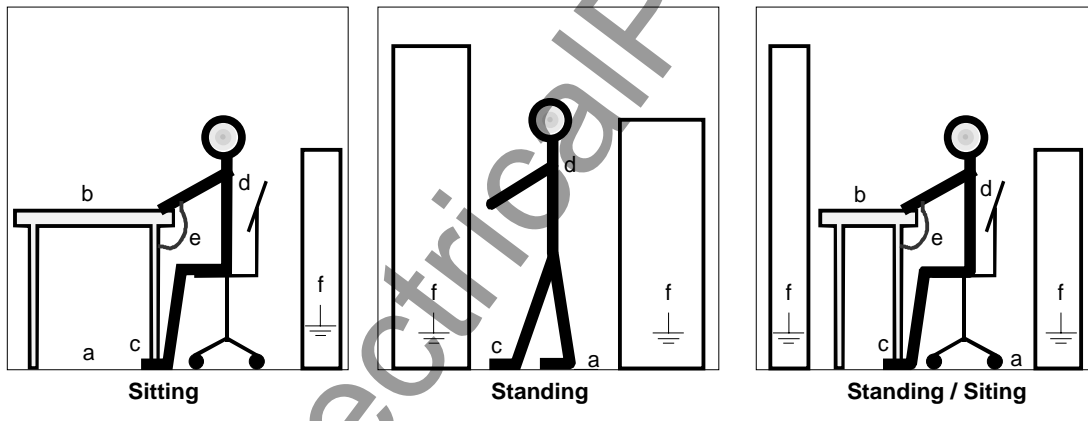

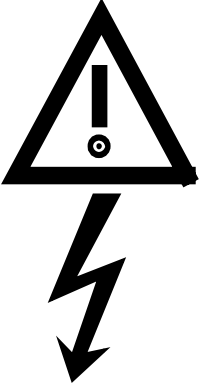
	WARNING
	<p>Hazardous voltages are present in this electrical equipment during operation.</p> <p>Non-observance of the safety instructions can result in severe personal injury or property damage.</p> <p>Only qualified personnel should work on or around the equipment after first becoming thoroughly familiar with all warning and safety notices and maintenance procedures contained herein.</p> <p>The successful and safe operation of this equipment is dependent on proper handling, installation, operation and maintenance.</p>

Safety and operating instructions for drive converters

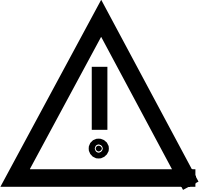
	<p>Safety and operating instructions for drive converters</p> <p>(in conformity with the low-voltage directive 73/23/EEC)</p>
<p>1. General</p> <p>In operation, drive converters, depending on their degree of protection, may have live, uninsulated, and possibly also moving or rotating parts, as well as hot surfaces.</p> <p>In case of inadmissible removal of the required covers, of improper use, wrong installation or maloperation, there is the danger of serious personal injury and damage to property.</p> <p>For further information, see documentation.</p> <p>All operations serving transport, installation and commissioning as well as maintenance are to be carried out by skilled technical personnel (Observe IEC 364 or CENELEC HD 384 or DIN VDE 0100 and IEC 664 or DIN/VDE 0110 and national accident prevention rules!).</p> <p>For the purposes of these basic safety instructions, "skilled technical personnel" means persons who are familiar with the installation, mounting, commissioning and operation of the product and have the qualifications needed for the performance of their functions.</p> <p>2. Intended use</p> <p>Drive converters are components designed for inclusion in electrical installations or machinery.</p> <p>In case of installation in machinery, commissioning of the drive converter (i.e. the starting of normal operation) is prohibited until the machinery has been proved to conform to the provisions of the directive 89/392/EEC (Machinery Safety Directive - MSD). Account is to be taken of EN 60204.</p> <p>Commissioning (i.e. the starting of normal operation) is admissible only where conformity with the EMC directive (89/336/EEC) has been established.</p> <p>The drive converters meet the requirements of the low-voltage directive 73/23/EEC. They are subject to the harmonized standards of the series prEN 50178/DIN VDE 0160 in conjunction with EN 60439-1/ VDE 0660, part 500, and EN 60146/ VDE 0558.</p> <p>The technical data as well as information concerning the supply conditions shall be taken from the rating plate and from the documentation and shall be strictly observed.</p>	

3. Transport, storage

The instructions for transport, storage and proper use shall be complied with.

The climatic conditions shall be in conformity with prEN 50178.

4. Installation

The installation and cooling of the appliances shall be in accordance with the specifications in the pertinent documentation.

The drive converters shall be protected against excessive strains. In particular, no components must be bent or isolating distances altered in the course of transportation or handling. No contact shall be made with electronic components and contacts.

Drive converters contain electrostatic sensitive components which are liable to damage through improper use. Electric components must not be mechanically damaged or destroyed (potential health risks).

5. Electrical connection

When working on live drive converters, the applicable national accident prevention rules (e.g. VBG 4) must be complied with.

The electrical installation shall be carried out in accordance with the relevant requirements (e.g. cross-sectional areas of conductors, fusing, PE connection). For further information, see documentation.

Instructions for the installation in accordance with EMC requirements, like screening, earthing, location of filters and wiring, are contained in the drive converter documentation. They must always be complied with, also for drive converters bearing a CE marking. Observance of the limit values required by EMC law is the responsibility of the manufacturer of the installation or machine.

6. Operation

Installations which include drive converters shall be equipped with additional control and protective devices in accordance with the relevant applicable safety requirements, e.g. Act respecting technical equipment, accident prevention rules etc. Changes to the drive converters by means of the operating software are admissible.

After disconnection of the drive converter from the voltage supply, live appliance parts and power terminals must not be touched immediately because of possibly energized capacitors. In this respect, the corresponding signs and markings on the drive converter must be respected.

During operation, all covers and doors shall be kept closed.

7. Maintenance and servicing

The manufacturer's documentation shall be followed.

Keep safety instructions in a safe place!

1 Control terminal strip and serial interface

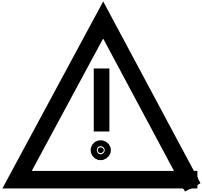
	WARNING
	The unit must be disconnected and locked-out before control cables are connected to the CU.

The unit can be controlled via the following interfaces:

- ◆ Control terminal strip -X101 to -X103 on the electronics board CU
- ◆ RS485 (SST2) serial interfaces; control terminal strip -X100 on the electronics board CU.
- ◆ OP operator control panel (Section "Options" in the Operating Instructions, Part 1)
- ◆ RS485 and RS232 serial interfaces (SST1) on the PMU -X300

	CAUTION
	The CU board contains components which can be destroyed by electrostatic discharge. These components can be very easily destroyed if not handled with caution. Also refer to the ECB cautionary measures in the Section, General Information.

1.1 Connectors for the control terminal strip

The connectors for the control terminal strip are supplied (loose) with the unit. Cables with cross-sections from 0.14 mm² to 1.5 mm² (AWG: 26 to 16), or 1 mm² (AWG: 18) can be connected using stranded wire with lugs at the connector (recommended: 0.5 mm² (AWG: 20)). The connectors can be identified using the pin numbers (Table 1.1); the connector position on the board is illustrated in Fig. 1.1. Two screen clamps and four cable ties are required from the loose components supplied to connect the control cables.

The remaining connector X9, included loose with the equipment, is required to control a main contactor and for connecting an external power supply (Section „Auxiliary power supply/main contactor“ in the Operating Instructions, Part 1).

Connector	Labeling
X100	12-pin, coded 1 2 3 CU2 6 7 8 9 10 11 12
X101	12-pin, coded 13 14 15 CU2 18 19 20 21 22 23 25
X102	10-pin ◆ 25 26 27 28 CU2 31 32 33 34
X103	10-pin, coded 35 36 37 38 CU2 41 42 43 44

Table 1.1 Connectors for the control terminal strip are supplied loose

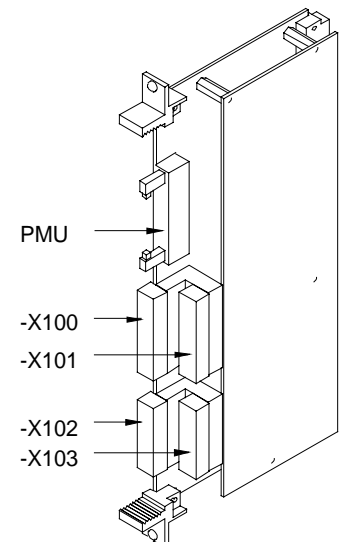

Fig. 1.1 Control terminals on CU

1.1.1 Connecting-up the control cables

NOTE

As a general rule, it is recommended that shielded control wiring be used for signals connected directly to the chassis, in order to achieve maximum noise immunity. The shield must be grounded at both ends.

To avoid noise coupling, control wires which are directly connected to the chassis should be separated from power wiring by a minimum distance of 20 cm.

For drives wired in approved factories, internal wiring practices which achieve acceptable noise immunity results may be used for drive connections.

Control- and cables must cross each other at an angle of 90°.

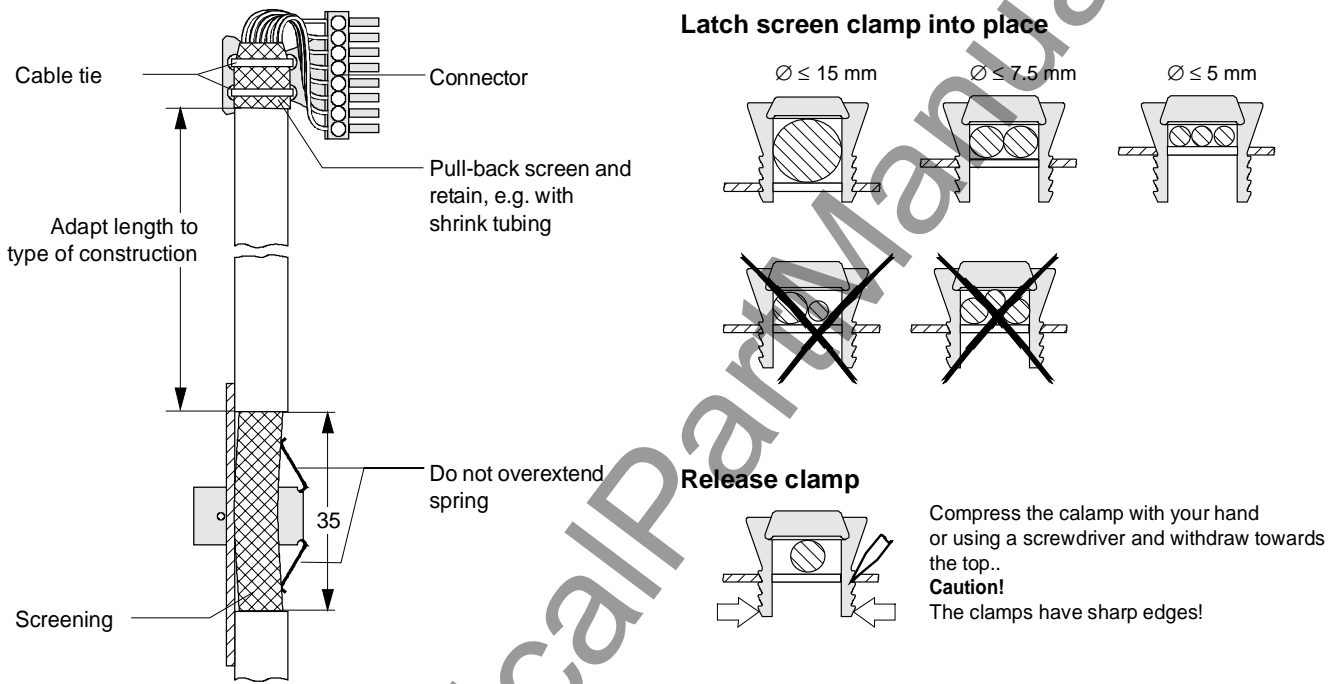

Fig. 1.2 Connecting-up the control cables and the technique for using the screen clamps

The "EMC screened housing" option should be used if so many control cables are required that two screen clamps are not sufficient.

Order No.:

- ◆ Type A 6SE7090-0XA87-3CA0
- ◆ Type B 6SE7090-0XB87-3CA0
- ◆ Type C 6SE7090-0XC87-3CA0
- ◆ Type D 6SE7090-0XD87-3CA0

1.2 Terminal connection

Connecting example	Term.	Function, notes				
	-X100					
	1	Transmit- and receive line -RS485, differential input / -output, positive (RS485R/T+)				
	2	Transmit- and receive line -RS485, differential input / -output, negative (RS485R/T-)				
	3	Transmit output RS485 Standard, differential output, positive (RS485T+)				
	4	Transmit output RS485 Standard, differential output, negative (RS485T-)				
	5	Reference potential, RS485 interface				
	NOTE	In addition to the GSST_2 interface on -X100, a GSST_1 interface -X300 is available on the parameterization unit; see Chapter 4 „Start-up“.				
	NOTE	Binary output 1 is connected at -X9:4,5 main contactor control				
	6	Binary output 2 (changeover contact) reference contact				
	7	Binary output 2 (changeover contact) NO contact				
	8	Binary output 2 (changeover contact) NC contact				
	9	Binary output 3 (NO contact) reference contact				
10	Binary output 3 (NO contact) NO contact					
11	Binary output 4 (NO contact) reference contact					
12	Binary output 4 (NO contact) NO contact					
NOTE	Load capability of the binary outputs: <ul style="list-style-type: none"> 60 V AC, 60 VA, $\cos\phi = 1$ 60 V AC, 16 VA, $\cos\phi = 0.4$ 60 V DC, 24 W Inductive loads, e.g. contactors, relays, for DC voltage loads, must be damped using a diode or varistor, and for AC loads, with a varistor or RC element.					
-X101						
13	+24 V, 75 mA for binary inputs and outputs (150 mA if term. 23 unassigned)					
14	Ref. potential for 24 V (ground)					
15	Ref. potential for binary inputs 1 to 7 for ext. signal voltage					
16	Binary input 1					
17	Binary input 2					
18	Binary input 3					
19	Binary input 4					
20	Binary input 5					
21	Binary input 6					
22	Binary input 7					
NOTE	Signal sensitivity of the binary inputs: <table style="display: inline-table; vertical-align: middle;"> <tr> <td>H = 24 V (13 V to 33 V)</td> <td>$I_{max} = 15.7 \text{ mA}$</td> </tr> <tr> <td>L = 0 V (-0.6 V to 3 V)</td> <td></td> </tr> </table>		H = 24 V (13 V to 33 V)	$I_{max} = 15.7 \text{ mA}$	L = 0 V (-0.6 V to 3 V)	
H = 24 V (13 V to 33 V)	$I_{max} = 15.7 \text{ mA}$					
L = 0 V (-0.6 V to 3 V)						
23	+24 V, 75 mA for binary inputs and outputs (150 mA if term. 13 unassigned)					
24	Ref. potential for 24 V					

Table 1.2 Connecting example for control terminal strips -X100 and -X101

Connecting example	Term.	Function, notes
	-X102	
	25	+10 V / 5 mA, ±2 %, for setpoint pot., non-floating
	26	-10 V / 5 mA, ±2%, for setpoint pot., non-floating
	27 ¹⁾	Analog input 1 (0 V to ±10 V)
	28	Ref. potential, analog input 1
	29 ¹⁾	Analog input 1 (0 mA to 20 mA or. 4 mA to 20 mA) int. load resistor 250 Ω
	30 ²⁾	Analog input 2 (0 V to ±10 V)
	31	Ref. potential, analog input 2
	32 ²⁾	Analog input 2 (0 mA to 20 mA or 4 mA to 20 mA) int. load resistor 250 Ω
	33	Ref. potential, analog output 1
34	Analog output 1 (0 V to 10 V) permissible load ≤ 5 mA Δ > 2 kΩ	
NOTE		Terminals 33 and 34: To increase the noise immunity of the signals, an isolating amplifier should be connected between the analog output and measuring unit for cables > 4 m.

Table 1.3 Connecting-up example for the control terminal strip -X102

Connecting example	Term.	Function, notes	
	-X103		
	35	Ref. potential for digital tacho	
	36	Track A, digital tacho	
	37	Track B, digital tacho	
	38	Zero track, digital tacho	
	39	Check input, digital tacho	
	40	+15 V, 190 mA, digital tacho power supply	
	NOTE		As standard, an HTL encoder without differential outputs can be connected. Option DTI is required for other applications (digital tacho interface).
	41	Ref. potential for the motor temperature sensor	
	42	Motor temperature input (KTY84)	
NOTE		Protective separation must be externally guaranteed.	
43	Ref. potential, analog output 2		
44	Analog output 2 (0 V bis 10 V) permissible load ≤ 5 mA Δ > 2 kΩ		
NOTE		Terminals 43 and 44: Isolating amplifiers should be connected between the analog output and measuring unit to increase the signal noise immunity for cable lengths > 4 m.	

Table 1.4 Connecting-up example for control terminal strip -X103

1) Only one of the two terminals, 27 or 29, may be assigned
 2) Only one of the two terminals, 30 or 32, may be assigned

1.2.1 Connecting-up the parameterizing unit (PMU)

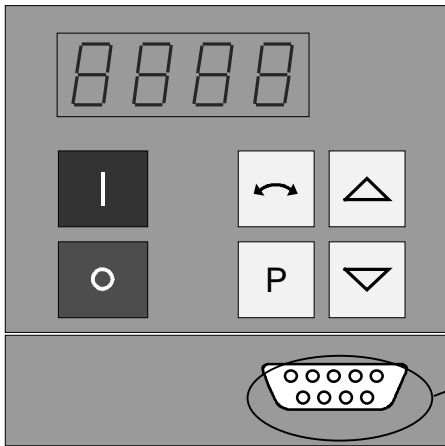

A serial connection to automation unit or a PC can be realized via connector X300 on the PMU. Thus, the unit can be controlled and operated from the central control station or control room.

For degree of protection IP20 (option), there is no PMU. The OP1 operator control panel must be removed to connect a PC or an automation unit to X300 (to remove OP1, release the 2 mounting screws on the inside of the doors).

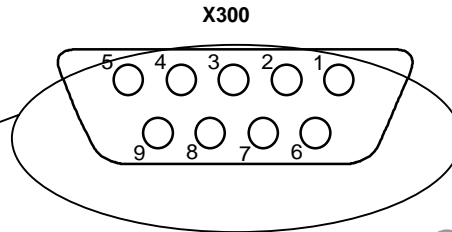

Fig. 1.3 Parameterizing unit (PMU)

PMU -X300	Description
1	Not assigned
2	Receive line, RS232 standard (V.24)
3	Transmit- and receive line, RS485, two-wire, positive differential input/output
4	RTS (request to send)
5	Ref. potential (ground)
6	5 V power supply for OP
7	Transmit line, RS232 standard (V.24)
8	Transmit- and receive line RS485, two-wire, negative differential input/output
9	Ref. potential for RS232- or RS485 interface (EMC suppressed).

Table 1.5 Connector assignment for interface -X300

1.3 Measures to maintain the radio interference suppression regulations

The drives must be installed and mounted according to the „Installation Instructions for EMC-correct installation and mounting of drives“ (Order No. 6SE7087-6CX87-8CE0).

The limit values for industrial environments can be maintained without radio interference suppression filter. B1 radio interference suppression filters must be used for environments other than industrial environments.

The following points must be observed regarding radio interference suppression regulations:

◆ Grounding

Converters generate radio interference noise. This noise should be fed back to the source through the lowest possible ohmic connection (ground connection cross-section \geq supply connection cross-section).

Use the best grounding possibility (e.g. mounting panel, grounding cable, grounding bar) when installing converters and optional radio interference suppression filters. Connect all connector housings together through the largest possible surface area.

For radio interference suppression, the cross-section (observe the safety regulations under fault conditions), is not so important, but the contact surface, as high-frequency noise currents do not flow through the complete cross-section, but essentially on the outside surface of a conductor (skin effect).

◆ Screening

In order to reduce noise and maintain the radio interference suppression level, the following should be maintained

- screened cables should be used between the converter output and motor
- screen control cables must be used.
- route control- and power cables separately; min. clearance, 20 cm.

The screen must be connected to ground potential at both ends.

- ◆ Control cables and power cables may only cross at an angle of 90 °.

◆ Filter

The radio interference suppression filter must be connected directly in front of the rectifier- or rectifier and regenerative feedback unit. The housings must be connected electrically with one another.

2 Operator control

The converter can be controlled via:

- ◆ the PMU (Parameterization Unit)
- ◆ the control terminal strip on the CU (Chapter 1 „Control terminal strip“)
- ◆ the OP1 operator control panel (Chapter „Options“ in the Operating Instructions, Part 1)
- ◆ the RS485 and RS232 serial interface on PMU -X300

When the equipment is shipped, the drive converter is controlled and parameterized by the parameterizing unit (PMU) on the front side of the unit.

For option M20 (degree of protection IP20), the unit is controlled and parameterized via the OP1.

Operator control using the PMU is described in this section.

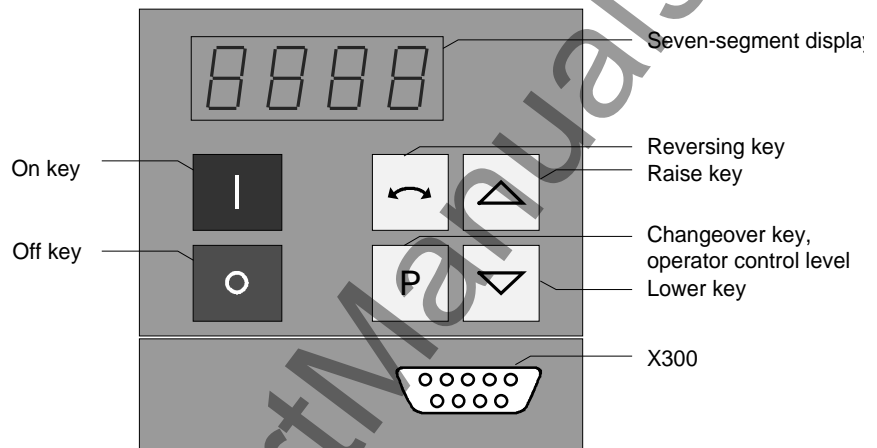

Fig. 2.1 Parameterization unit

2.1 Operator control elements

Operator control elements	Function
	Converter switch on (standard). For faults: Return to the fault display. Command is effective when the key is released.
	Converter shutdown depending on the parameterization of OFF1, OFF2 or OFF3 (P554 to P560). Command becomes effective when the key is released.
	Field reversal / reversing for the appropriate parameterization (P571 and P572). Command becomes effective when the key is released.
	Changeover from parameter number to parameter value. In conjunction with other keys, additional functions (refer to Figs. 2.2 to 2.5). Command becomes effective when the key is released.
,	Values (raise, lower) change as long as the keys are depressed.
, ,	Depress P and hold, then depress the second key. The command becomes effective when the key is released (e.g. fast changeover).

Table 2.1 Function of the operator control elements on the PMU

2.2 Displays









		Parameter number		Index e.g..	Parameter value e.g.
		Pos. actual value e.g	Neg. actual value e.g		
Visualization parameters	Basic converter			---	
	Technology board				
Setting parameters	Basic converter			, 000	
	Technology board				

Table 2.2 Displaying visualization- and setting parameters on the PMU



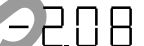

	Actual value	Parameter value not possible	Alarm	Fault
Display				

Table 2.3 Status display on the PMU

NOTE
The parameter description is provided in Chapter 11 „Parameter list“.

2.3 Structure

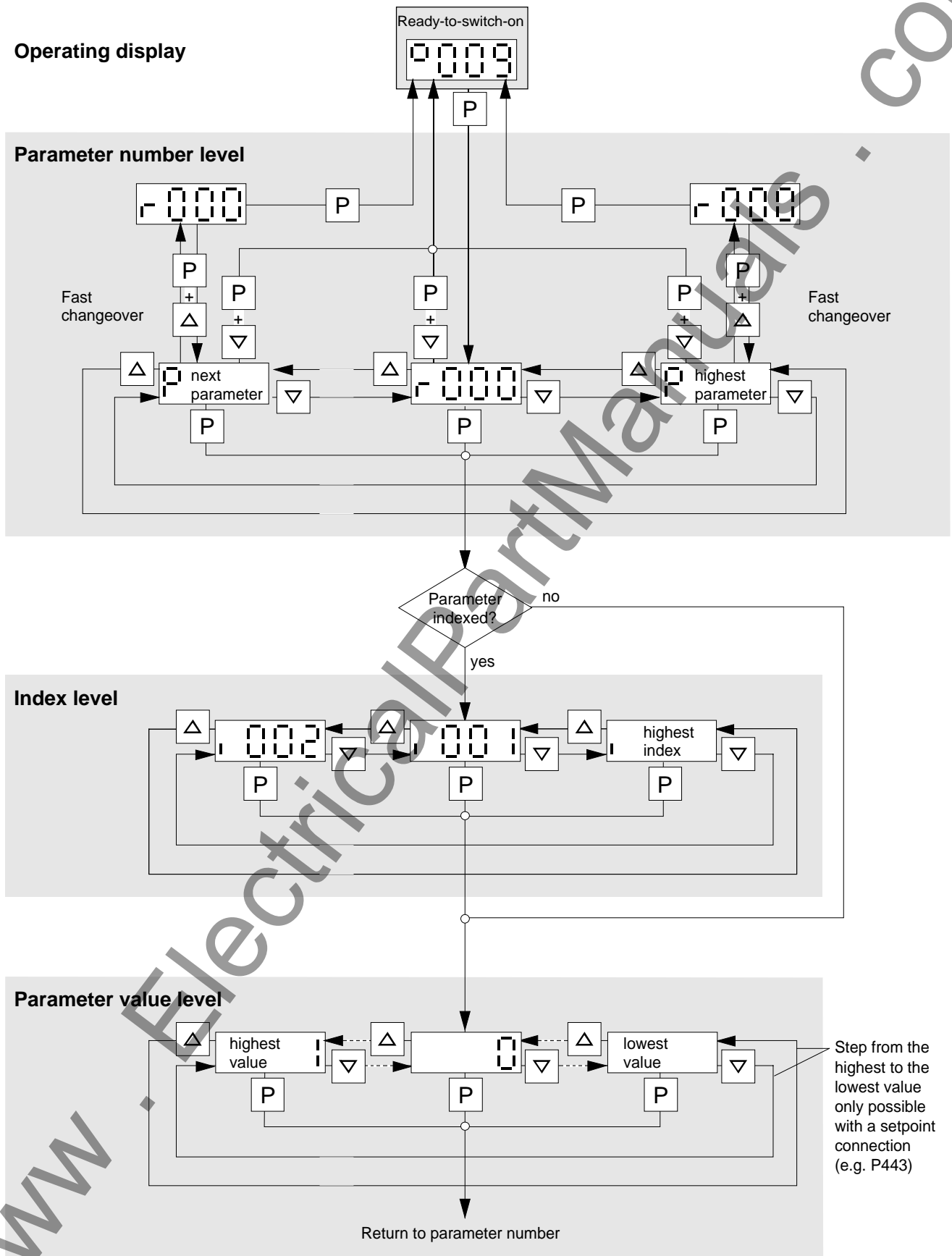
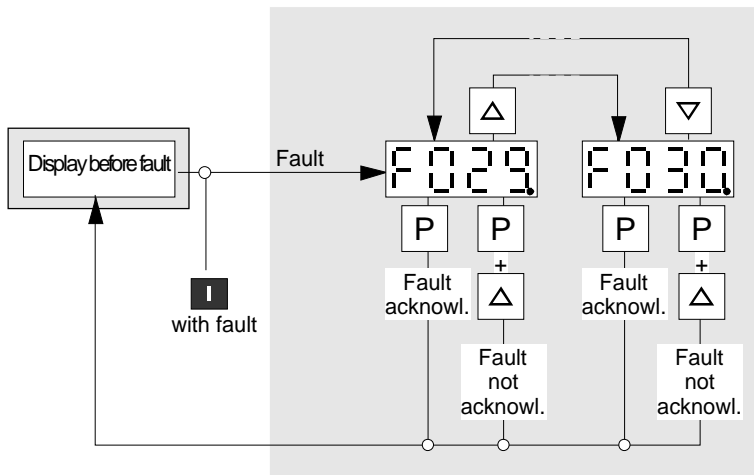

Fig. 2.2 Operator control structure using the PMU



If several fault exist, the particular fault can be selected using the Δ▽ keys.

P- + Δ key: Jump into the parameterizing level, if, e.g., fault acknowledgement is not possible.

Fig. 2.3 Operator control structure of the PMU for faults

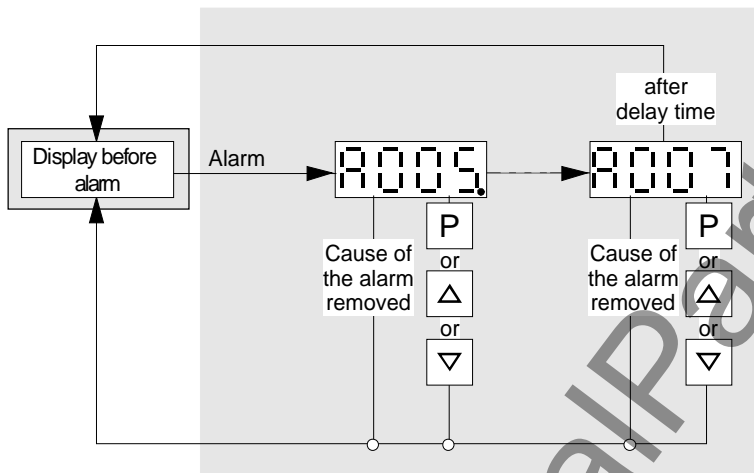

If several alarms are present, then display automatically switches to the higher alarm.

P- + Δ- or ▽ key: Jump into the parameterizing level independent of the alarms which are present

Fig. 2.4 Operator control structure of the PMU for alarms

If several faults or alarms exist, a point appears at the right in the display 8888.

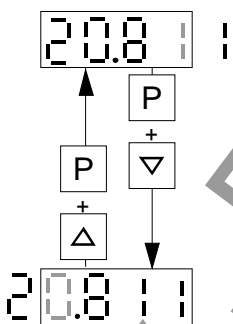

The shift is only possible in the parameter value level.

Fig. 2.5 Shifting the PMU display for parameter values with more than 4 digits

3 General explanation of the terminology and functional scope of the unit

Abbreviations:

- ◆ Abbreviations used: ☞ Chapter 14 „Index and Abbreviations“

3.1 Converter open-loop/closed-loop control versions

- ◆ Open-loop control versions (also suitable for multi-motor drives):
 - V/f characteristic:
Open-loop frequency control with constant voltage/frequency ratio, or a voltage/frequency ratio entered via a characteristic
 - V/f characteristic, for textile applications:
as for the V/f characteristic, however certain functions where the frequency setpoint (☞ function diagrams) is inhibited for textile machine applications.
 - ◆ Closed-loop control versions: V/f + closed-loop speed control (V/f characteristic with higher-level closed-loop speed control):
In addition to the specified V/f characteristic, in order to achieve an especially high speed accuracy, the motor speed, measured using a tachometer, is fed to a higher-level speed controller.
 - Closed-loop frequency control:
Closed-loop frequency control without tachometer according to the vector control principle (field-oriented control) for medium speed dynamic performance and accuracy.
 - Closed-loop speed control:
Closed-loop speed control with tachometer according to the vector control principle (field-oriented control) for high speed dynamic performance and accuracy.
 - Closed-loop torque control:
Closed-loop torque control with tachometer according to the vector control principle (field-oriented control) for high torque dynamic performance and accuracy.

Tip: For digital tachos and for certain analog tachos, option boards are required!

3.2 Process data

The following is understood under process data:

- ◆ **Setpoints** and **control commands**, which „directly“ influence the drive operating status,
- ◆ **Actual values** and **status messages**, which are „directly“ output from the drive.

„Directly“ means: Each process data change is realized immediately and without any acknowledgement - or handshake mechanisms.
Only then can fast process responses be achieved

Contrary to the process data, a parameter value change is subject to a specified mechanism, and consists of task and checkback signal.

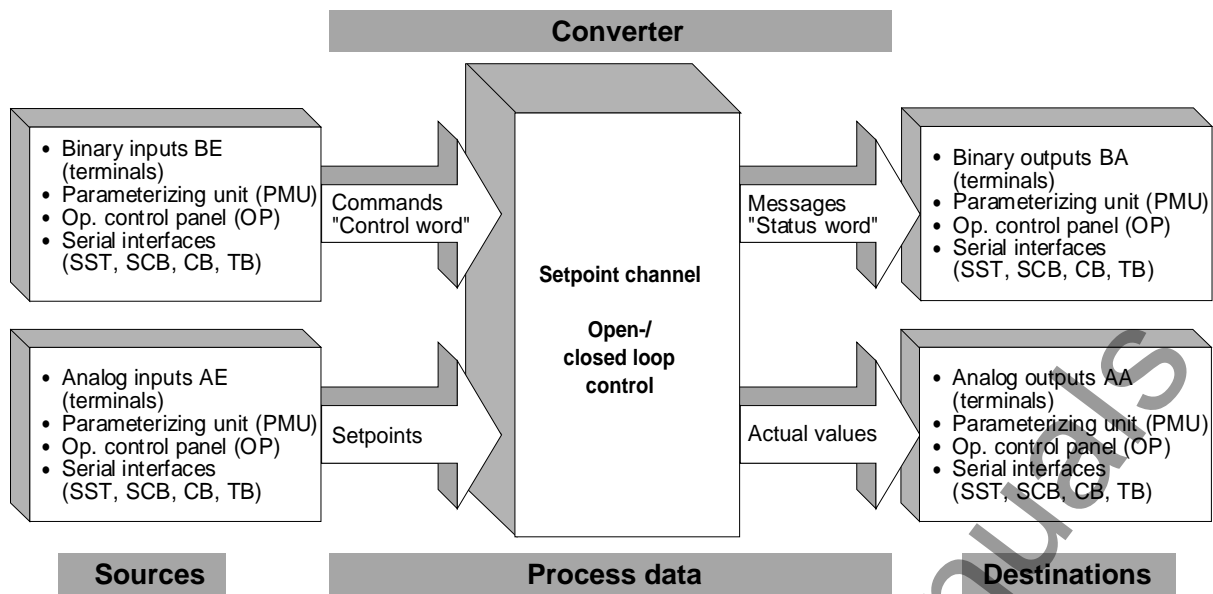

Fig. 3.1 Process data

3.3 Indexed parameters

Indexed parameters are sub-divided into various „indices“ (briefly: i001, i002, etc.), in which the particular parameter values can be entered.

The significance of the „indices“ of the particular parameter (parameter number) can be taken from the chapter 11 „Parameter list“.

Example:

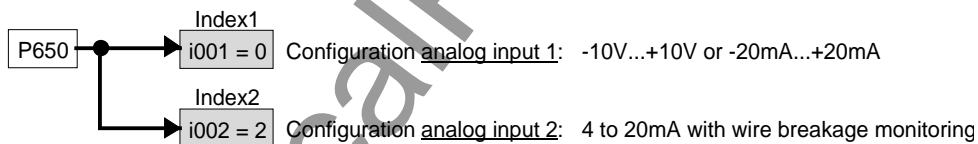

3.4 Data sets

„Indexed“ parameters can be sub-divided according to data sets (indexed).

There are three kinds of data sets:

- ◆ SDS (setpoint channel data set) 1 to 4:
4 setpoint channel data sets which can be changed over; e.g. for production-related different drive ramp-up and ramp-down times.
- ◆ Basic/reserve (basic- or reserve setting):
e.g. for changing over between manual and automatic operation
- ◆ MDS (motor data set) 1 to 4:
4 motor data sets which can be changed over; e.g. for operating different motor types from one converter.

The data sets are selected via the „control word“, and are read-out in r410, r012 and r152.

➤ Chapter 10 „Function diagrams“

4 Start-up

The drive converter must be ready. This means, that it must be installed and connected-up according to the information in the hardware description.

NOTE	
Forming:	If the drive converter was continuously shutdown for longer than a year, or not connected, then the DC link capacitors must be formed.

4.1 Capacitor forming

The DC link capacitors must be re-formed if the converter has been non-operational for more than one year. If the converter was started-up within one year after having been shipped (serial number on the rating plate), it is not necessary to re-form the DC link capacitors

For AC-AC, as well as for DC-AC drive converters, forming is realized by switching-in a rectifier and resistor, which are connected to the DC link (circuit configuration: refer to Figs. Fig. 4.2 and Fig. 4.3). The drive converter feed in this case must be shutdown (disconnected)!

A second possibility exists for DC-AC units. The DC busbar voltage is slowly increased up to the rated drive converter input voltage during the forming time.

The forming time is dependent on the time for which the drive converter stood. (refer to Fig. 4.1)

	Recommended components		
	A	R	C
3AC 208 V to 415 V	SKD 50 / 12	220 Ω / 100 W	22 nF / 1600 V
DC 280 V to 310 V			
3AC 510 V to 620 V	SKD 62 / 16	470 Ω / 100 W	22 nF / 1600 V
DC 380 V to 460 V			
3AC 675 V to 930 V	SKD 62 / 18	680 Ω / 100 W	22 nF / 1600 V
DC 500 V to 690 V			

Table 4.2 Recommended components for circuits acc. to Fig. 4.2 and Fig. 4.3

Position	Example	
1 and 2	A-	Manufacturing location
3	E	1994
	F	1995
	H	1996
4	1 to 9	January to September
	O	October
	N	November
	D	December
5 to 14		Not relevant for forming

Table 4.1 Serial number structure: A-E60147512345

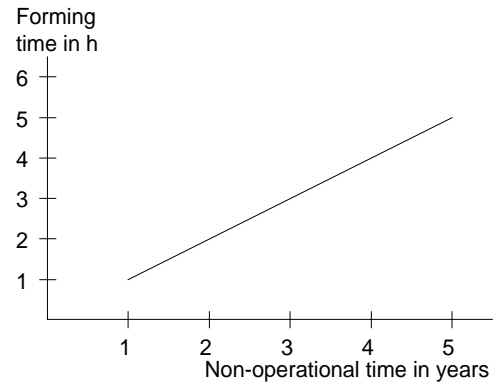

Fig. 4.1 Forming time as a function for the time which the converter was non-operational

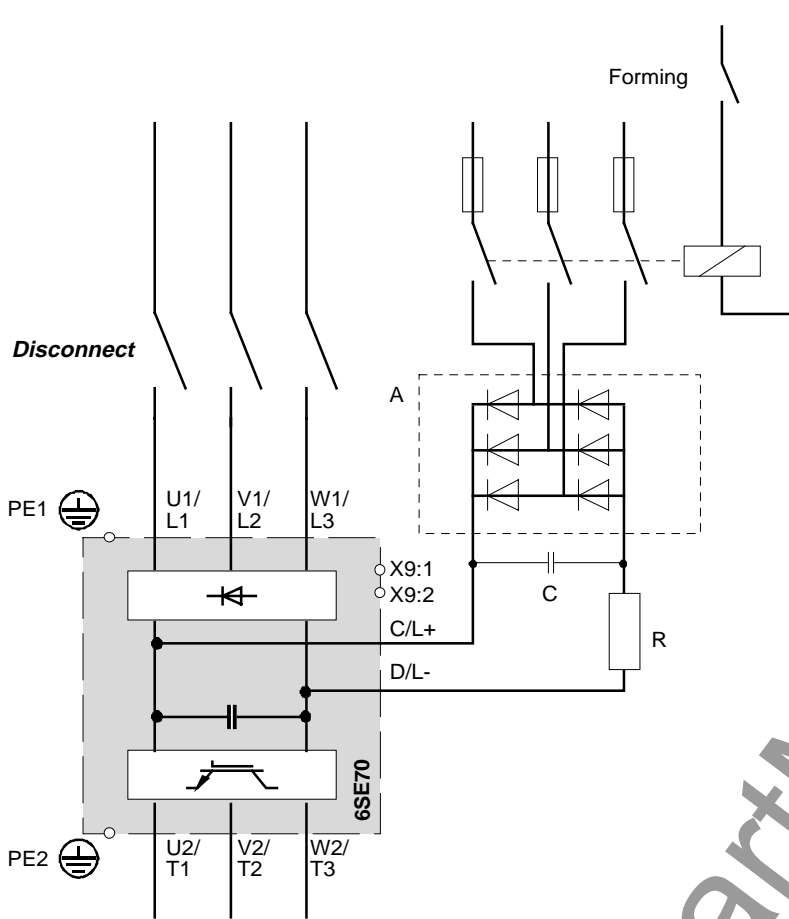

Fig. 4.2 Circuit to form AC-AC units

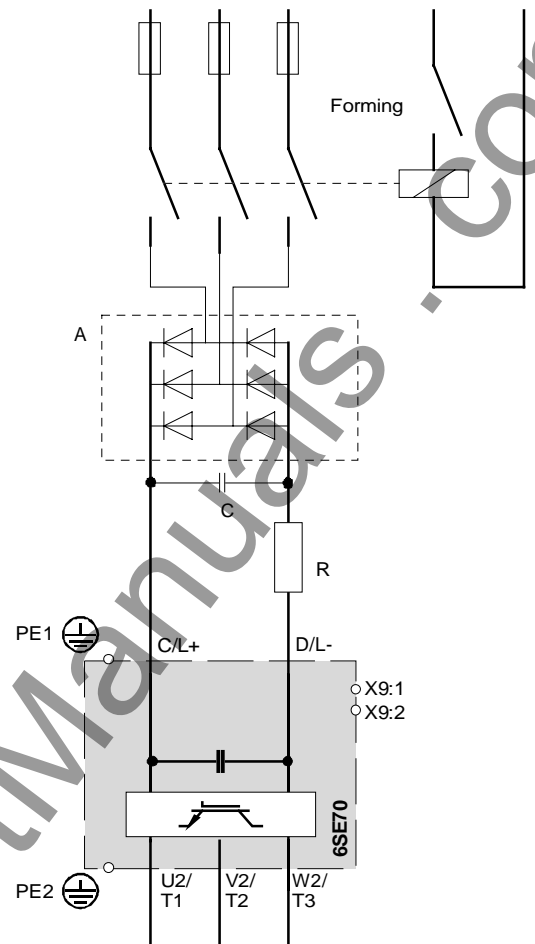

Fig. 4.3 Circuit to form DC-AC units

4.2 First start-up

The converter is supplied with the „Factory setting“ (see Chapter 11 „Parameter list“) and access stage 2 (standard mode). That means:

- ◆ The converter data correspond to the converter type, MLFB (Order No.) (converter initialized).
- ◆ A 50 Hz induction motor, adapted to the converter type, is parameterized, which is operated using the V/f control (open-loop).

If the required converter functions are already realized with the factory setting, the converter can be immediately switched-on and operated. Further parameterization is not required.

Parameterization is realized according to the following sections:

4.2.1 As „**Standard application with V/f characteristic without hardware options**“ for simple applications.

or **4.2.2** As „**Expert application**“ for sophisticated applications (e.g.: Closed-loop control, data set changeover, interface operation, etc.) of if hardware options are available.

4.2.1 Parameterization „Standard application“

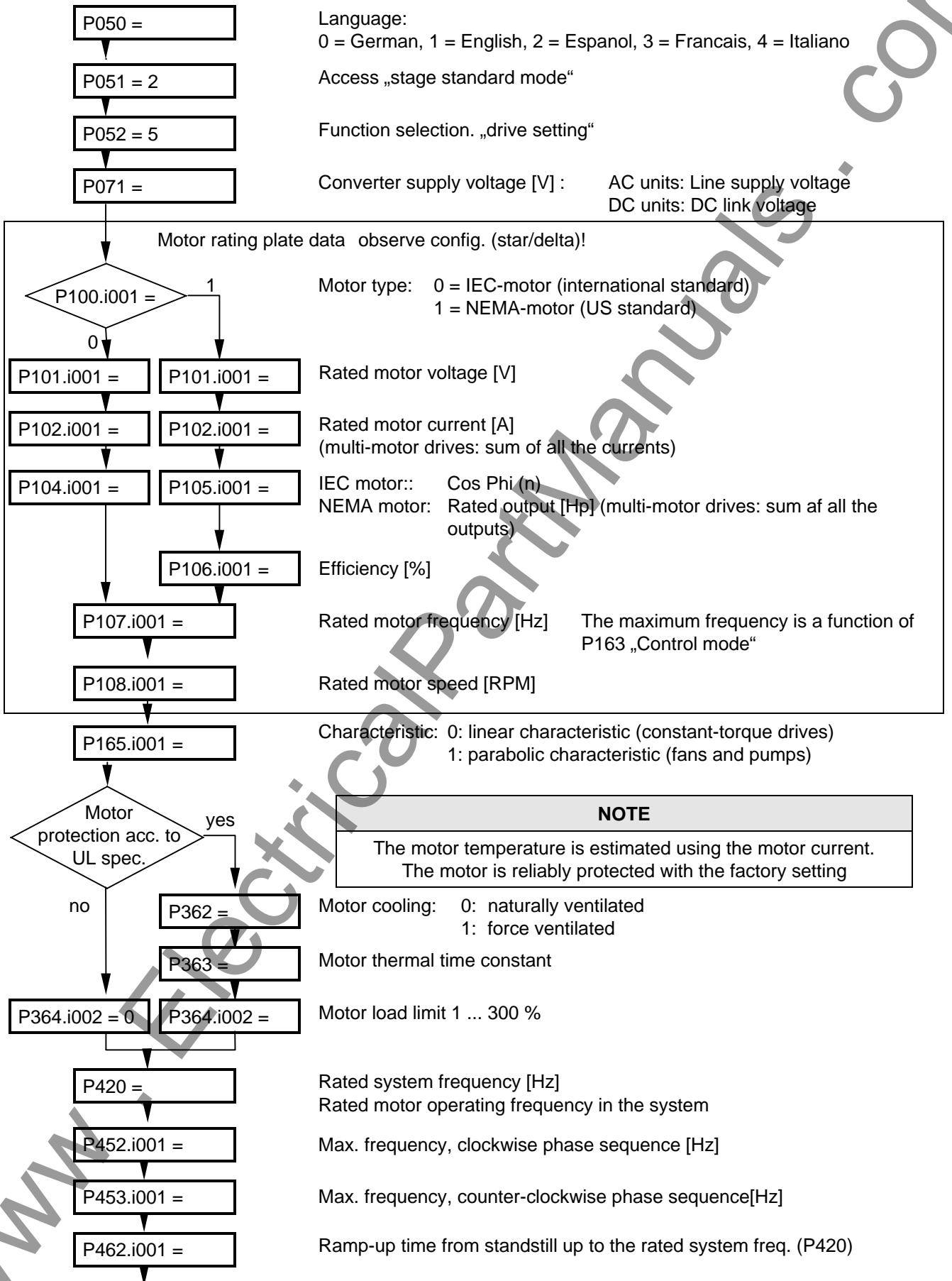

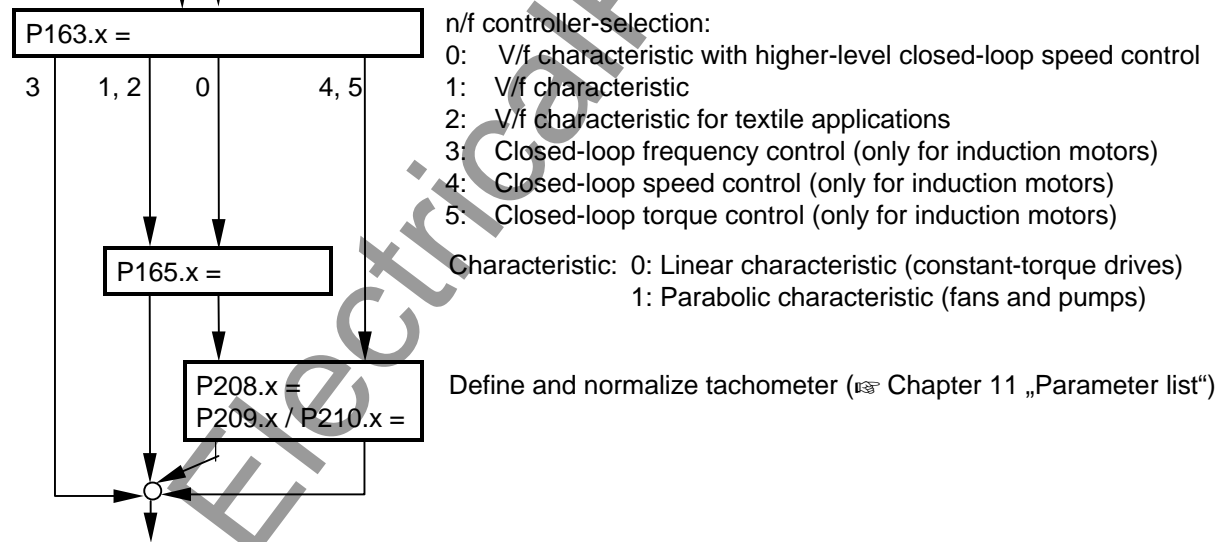
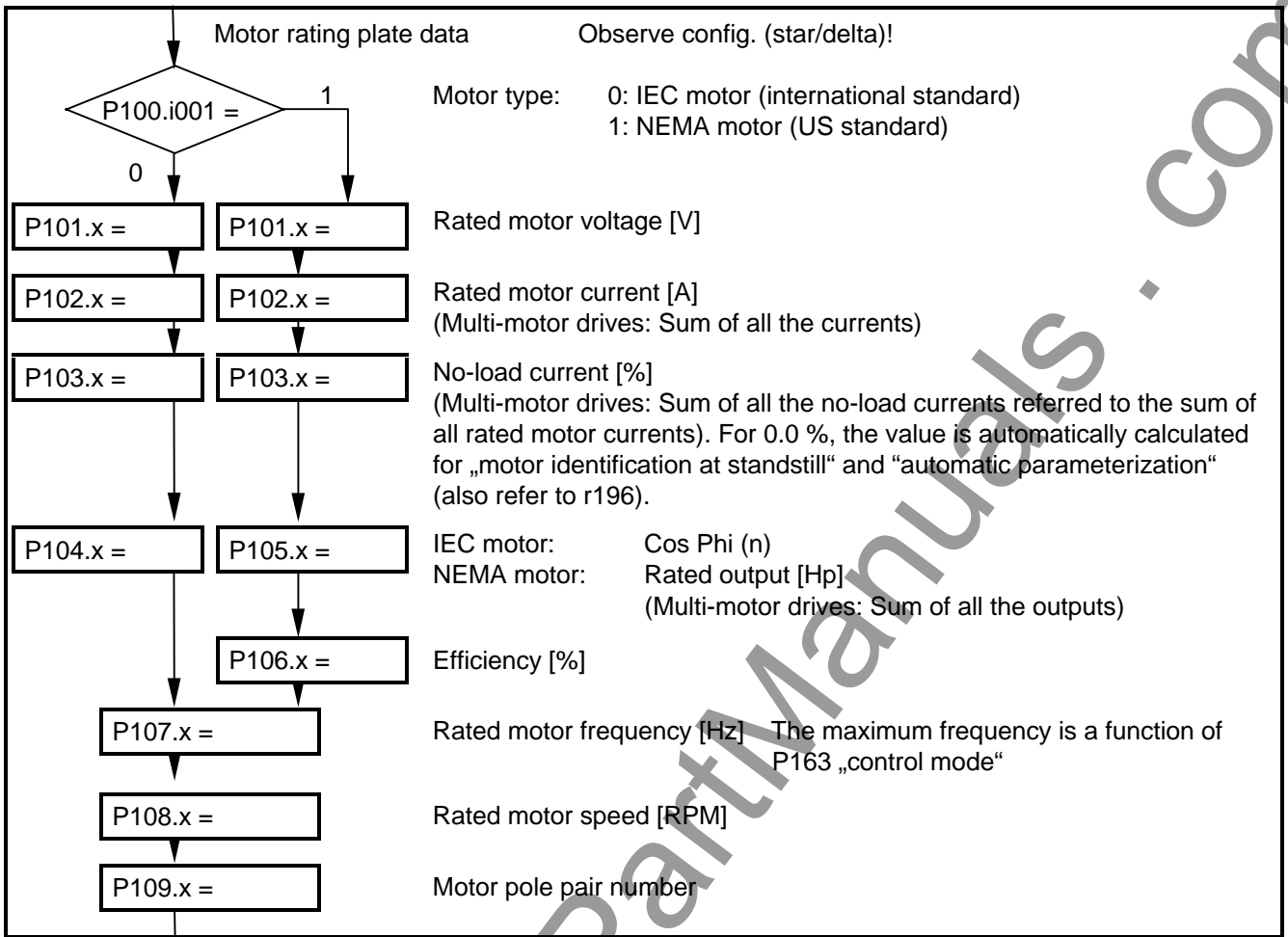

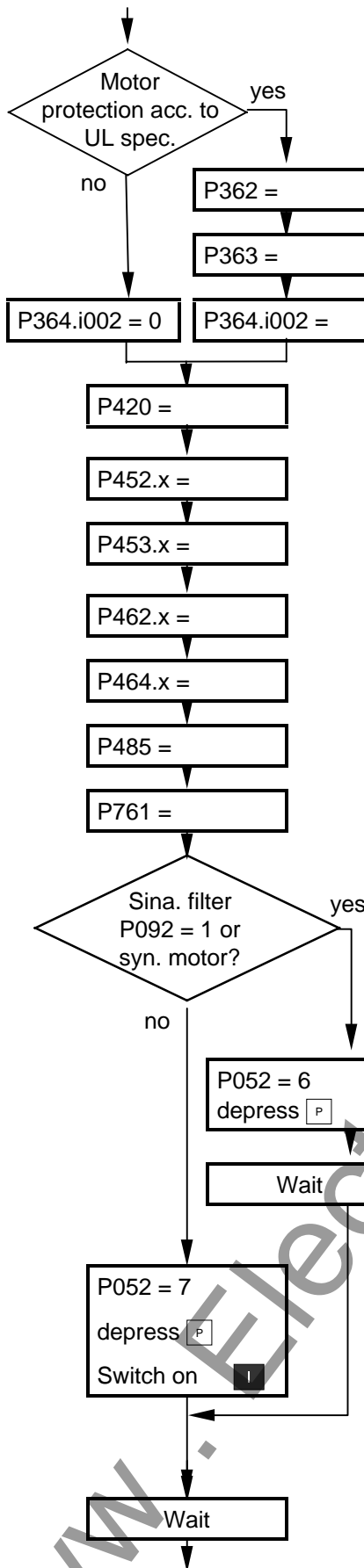

NOTE

The motor temperature is estimated using the motor current.
The motor is reliably protected with the factory setting

Motor cooling: 0: naturally ventilated
1: force ventilated

Motor thermal time constant

Motor load limit 1 ... 300 %

Rated system frequency [Hz]
Motor rated operating frequency in the system

Max. frequency, clockwise phase sequence [Hz]

Max. frequency, counter-clockwise phase sequence [Hz]

Ramp-up time from standstill up to the rated system freq. (P420)

Ramp-down time from the rated system freq. (P420) down to standstill

Rated system torque referred to the rated motor torque

Pulse frequency (see Chapter 11 „Parameter list“)

Function selection „automatic parameterization“

Wait until the converter is ready to switch on! (PMU display: 009)
If fault „Fxxx“ occurs see Chapter 12 „Fault and alarm messages“

Function selection „motor identification at standstill“
(includes „ground fault test“ and „automatic parameterization“)

NOTE

Current flows in the motor and the rotor can align itself!

Alarm „A078“ appears after the P key is depressed. The converter must be switched-on within 20s!

Wait until the converter shuts down!
If fault „Fxxx“ occurs see Chapter 12 „Fault and alarm messages“

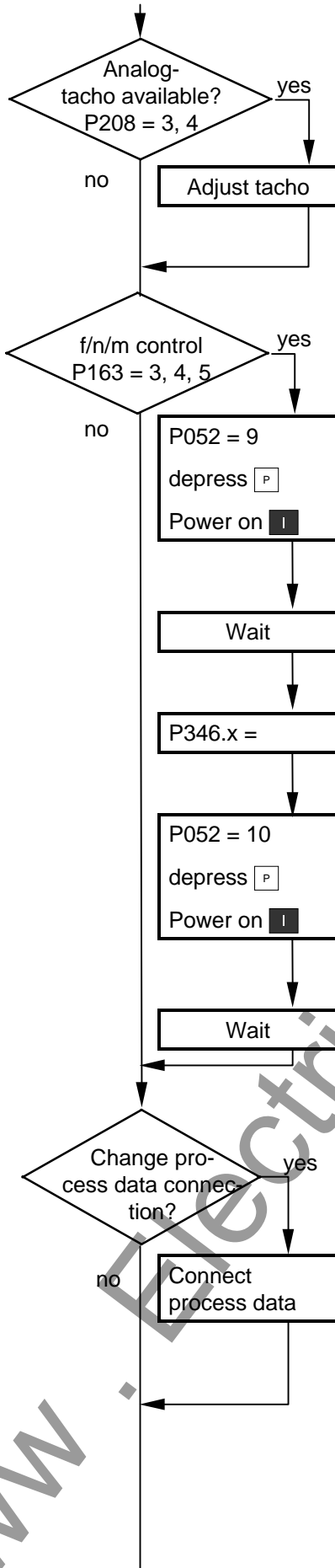

Adjust tacho:

- Tacho at ATI: refer to the ATI Instruction Manual
- Tacho at terminal strip CU:
 - ☞ Section 6.3 „Analog inputs“

Function selection „no-load measurement“

NOTE
Current flows in the motor and the rotor rotates!

Alarm „A080“ appears after the P key is depressed. The converter must be switched-on within 20 s!

Wait until the converter shuts down!

(operating display: 009 for „ready to switch-on“)

If fault „Fxx“ occurs, ☞ Chapter 12 „Fault and alarm messages“

Set the required dynamic performance of the speed control loop in [%] for the following „n/f controller optimization“! (100 % corresponds to an optimum)

Function selection „n/f controller optimization“

NOTE
Current flows in the motor and the rotor rotates!

Alarm „A080“ appears after the P key is depressed. The converter must be switched-on within 20 s!

Wait until the converter shuts down!

(operating display: 009 for „ready to switch-on“)

If fault „Fxx“ occurs, ☞ Chapter 12 „Fault and alarm messages“

Change factory setting for:

Command- and setpoint sources,
Destinations for signals and actual values

Process data: (☞ Chapter 5 „Process data“)

- Control word (commands)/status word (messages)
- Setpoint/actual values

Possible process data sources/destinations: (Sections 5.1 to 5.3)

- Binary inputs, binary outputs
- Analog inputs, analog outputs
- Serial interface in the basic converter (SST1, SST2)
- Option boards (SCB, TSY, CB, TB)

Simple applications: ☞ Section 4.5

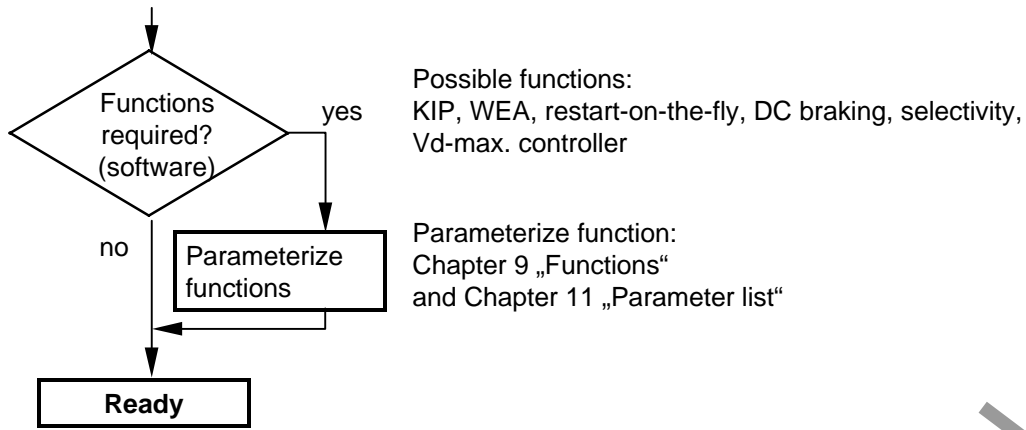

- ◆ detailed parameter description: ➤ Chapter 11 „Parameter list“
- ◆ detailed function diagrams: ➤ Chapter 10 „Function diagrams“

4.3 Drive start-up when the drive converter is controlled through an external main contactor

It is not absolutely necessary that the converter is operated with a main- or output contactor. If the converter control functions have to be maintained with the main contactor open, an external 24 V DC power is required. Binary output 1 (-X9:4,5) is provided to control the contact (pre-assigned P612). The checkback signal can be wired to a binary input (e.g. binary input 3).

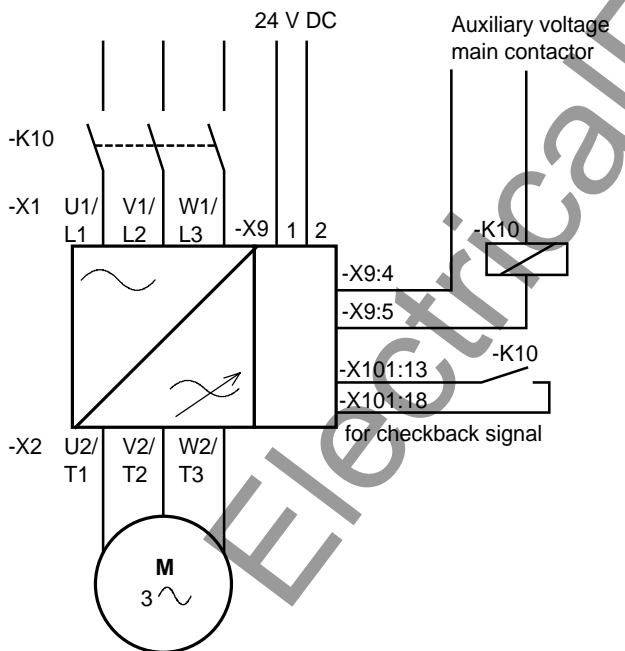

Fig. 4.4 Example for connecting a main- and input contactor

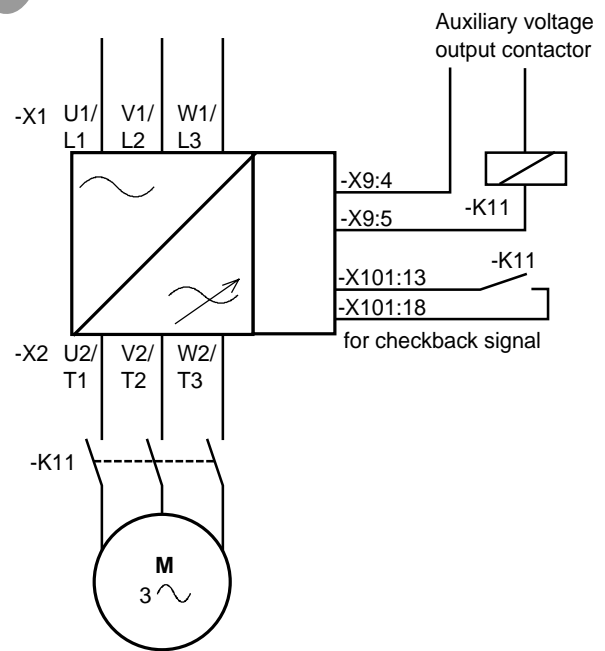

Fig. 4.5 Example for connecting an output contactor

Sequence control, on command-operation (effect on the main- or output contactor).

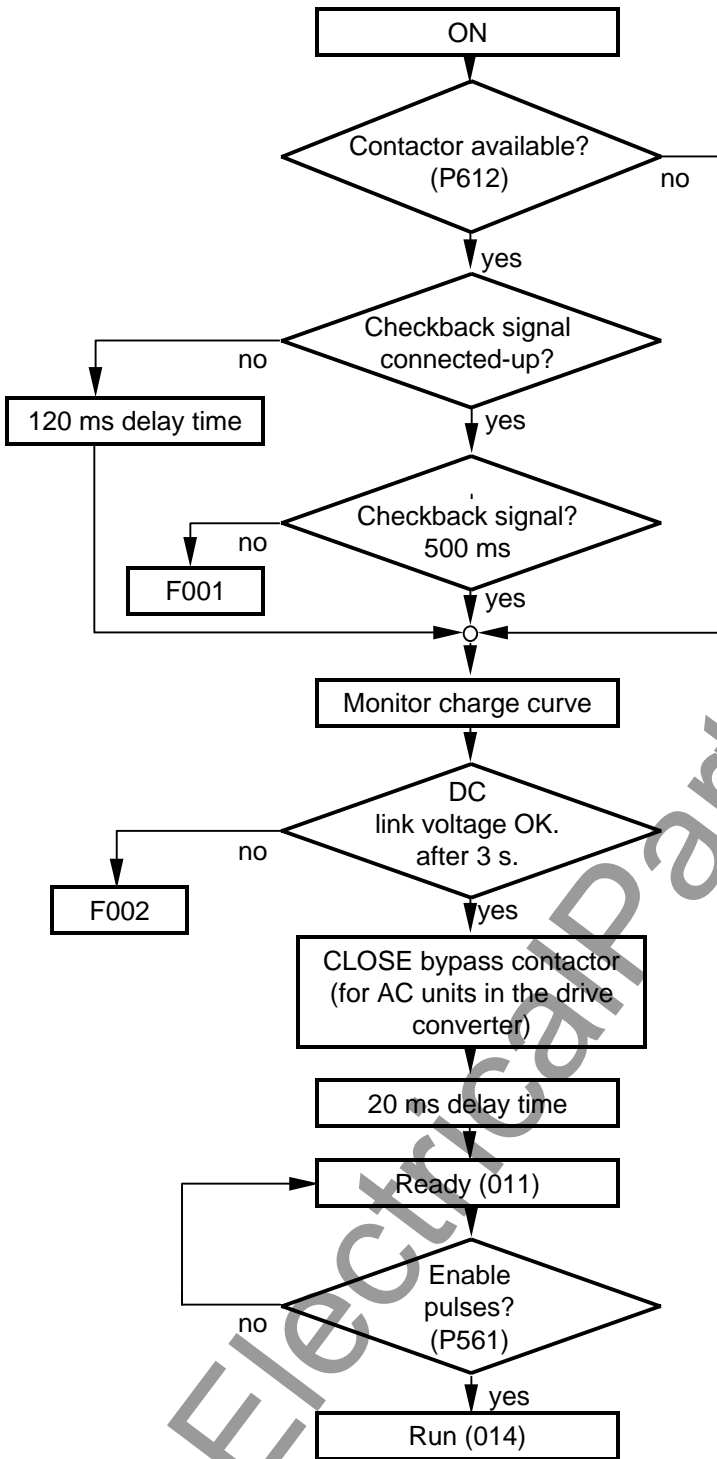

Fig. 4.6 Sequence control, on command- operation

Parameter- No.	Name	Index	Parameter- value	Terminal	With contactor(s)	Contactor(s) with checkback signals
P612	Dst.MC energized	i001	1001	X9: 4,5	X	X
P591	Src MC chckbck sig. binary input 3	-	1003	X101:18		X

Table 4.3 Recommended parameterization for the main- and output contactors

4.4 Drive start-up after enabling additional software functions or hardware options

If new software functions were enabled in the drive converter or hardware options installed, start-up must be repeated. This must be realized using the same steps as for first start-up:

- Standard application; ☞ refer to Section 4.2.1
- Expert application: ☞ refer to Section 4.2.2

NOTES

- ◆ Depending on the required change and taking into account the access stage (P051), and a possibly necessary function selection (P052), a jump can be made to the appropriate step.
- ◆ Due to background calculations, it is recommended that the following parameters and functions selections are checked/executed after the position jumped to!

For example:

Standard application (Section 4.2.1): Changing motor data

- ◆ P051 = 2 Access stage
- ◆ P052 = 5 Function selection, „drive setting“
- ◆ Change motor data
- ◆ Check subsequent parameters
- ◆ P052 = 7 Select „motor identification at standstill“ function (background calculations using new motor data)

4.5 Simple application examples for connecting process data with connection assignment

Connecting-up: Chapter 1 „Control terminal strip“

Multiple use of control word bits and source connections are permitted.

Caution: This excludes undesirable connections; e.g. factory setting basic/reserve changeover connected at binary input 5 (P590 = 1005)

4.5.1 Factory setting

Switch-on/off as well as setpoint input via the PMU, messages and actual values via the terminal strip.

Terminal strip only operational if binary input 5 (BE5) is energized (high signal level corresponds to „reserve“).

If BE5 is open (low signal level), then operator control is realized via the PMU.

The factory setting shown is not valid for cabinet units (compare P077)

Basic setting Controlling via PMU	Switch-on/off, setpoint input	Reserve setting Controlling via terminal strip
CU2 -X101/13 P24 -X101/20 BE5		CU2 -X101/13 P24 -X101/20 BE5
P554.1 = 1010 P555.1 = 1 P565.1 = 0 P573.1 = 1010 P574.1 = 1010	PMU  no source only PMU	P554.2 = 1001 P555.2 = 1002 P565.2 = 1003 P573.2 = 0 P574.2 = 0
	----- ON/OFF1 ----- -----OFF2 (pulse inhibit) ----- -----Acknowledge ----- -----Mot. pot., raise----- -----Mot. pot., lower -----	CU2 -X101/13 P24 -X101/16 BE1 -X101/17 BE2 -X101/18 BE3 no source no source

Fig. 4.7 Factory setting: Switsh-on/off as well as setpoint input

Examples of output connections:

Messages and setpoints	Parameter values / terminals
Floating contact-----	
Fault-----	P603.1 = 1002
Floating contact-----	
Operation-----	P602.1 = 1003
Basic/reserve-----	P590 = 1005
Speed/frequency actual value-----	P665.1 = 0218
Output current-----	P665.2= 0004

CU2

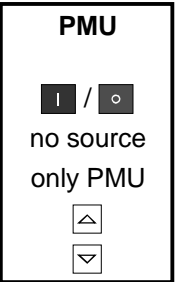





	-X100/06 BA2		
	-X100/07 BA2		
	-X100/09 BA3		
	-X100/10 BA3		
	-X101/13 P24		
	-X101/20 BE5		
	-X102/33 AA1M		
	-X102/34 AA1		
	-X103/43 AA2M		
	-X103/44 AA2		

Fig. 4.8 Factory setting: Messages and setpoints

4.5.2 Manual/automatic operation (Basic/reserve changeover)

Manual operation (BE5 low signal level): Setpoint- and command input via the terminal strip.

Automatic operation (BE5 high signal level): Setpoint-and command input from the automation unit via serial interface (SST2), the monitoring of external faults via a terminal strip also possible.

Recommended parameterization:

Manual operation, Controlling via terminal strip	Setpoint- and command input	Automatic operation
CU2 -X101/13 P24 -X101/20 BE5		CU2 -X101/13 P24 -X101/20 BE5
P554.1 = 1001 -X101/13 P24 P558.1 = 1002 -X101/16 BE1 P565.1 = 1003 -X101/17 BE2 P571.1 = 1004 -X101/18 BE3 P575.1 = 1006 -X101/19 BE4 P586.1 = 1007 -X101/21 BE6 P443.1 = 1004 -X101/22 BE7 -X102/30 AE2 -X102/31 AE2M	-----ON/OFF1 ----- ----- OFF3 (fast stop) ----- ----- Aknowledge ----- ----- cw phase seq. ----- ----- ccw phase seq. ----- ----- Fault, external 1 ----- ----- Fault, external 2 ----- ----- Main setpoint -----	P554.2 = 6001 SST2 control word P559.2 = 6001 P565.2 = 6001 P571.2 = 6001 P572.2 = 6001 P575.2 = 1006 Binary input 6 P586.2 = 1007 Binary input 7 P443.2 = 6002 SST2-word 2

Fig. 4.9 Manual / automatic: switsch-on/off as well as setpoint input

Examples of output connections:

Messages and setpoints	Parameter values / terminals
Floating contact -----	CU2 -X100/06 BA2 -X100/07 BA2 -X100/09 BA3 -X100/10 BA3 -X100/11 BA4 -X100/12 BA4 -X102/27 AE1 -X102/28 AE1M -X102/33 AA1M -X102/34 AA1 -X102/43 AA2M -X102/44 AA2
Operation -----	P602.1 = 1002
Floating contact -----	
RFG activ -----	P613.1 = 1003
Floating contact -----	
Clockwise phase sequence -----	P614.1 = 1004
Analog speed actual value from ATI -----	P208.1 = 0003
Output power -----	P655.1 = 0005
Torque -----	P655.2 = 0007

Fig. 4.10 Manual / automatic: Messages and setpoints

Tip: If a terminal cannot be connected-up as source or destination, it should be checked as to whether it has already been used for other signals.

5 Process data

5.1 Control word (control word 1 and control word 2)

Introduction and application example

An individual source can be parameterized for every control command, from where the control command may be output (fixed values, binary inputs, PMU, PZD part of the telegram from the automation devices).

The selection parameters for the sources are, with the exception of P590 and P591 are indexed 2x as follows:

- Index i001: Basic setting (GRD)
- Index i002: Reserve setting (RES)

One parameter is available to „connect-up“ the source(s) for the control commands.

Example for connecting-up the sources:

The basic setting for the ON command (control word bit 0, control word 1), should be „connected-up“ to binary input 1 of the CU (terminal -X101:16):

- ◆ From control word 1 table, one can identify that the factory setting of parameter P554.1 is 1010 for the basic setting of the ON command source.
- ◆ In Table A for the possible sources of the ON-command, one can see that 1010 corresponds to the „PMU operator control panel“ source.
- ◆ The parameter value for the required source is searched for in Tables X and A. For binary input 1 (BE1) of the CU, the result is found in table X, it is 1001.
- ◆ This parameter value must now be entered into parameter P554.1.

Command	Parameter	Possible sources	Parameter value	Required source connection
ON/OFF1 (GRD)	P554.1	Tab. X,A	1001	BE1 terminal -X101:16

A high signal at terminal -X101:16 powers-up the drive converter; a low signal powers-down the drive converter.

INFORMATION

- ◆ Multiple wiring is permitted!
- ◆ The control word commands „OFF2“ (bit 1), „OFF3“ (bit 2) and „acknowledge“ (bit 7) are always simultaneously effective from 3 sources (can be parameterized)!
- ◆ „Acknowledge“ (bit7) is additionally always effective from the PMU!
- ◆ If the „on“ command (bit 0) is connected to a serial interface (SST, CB/TB, SCB-SST), then the following must be observed for safety-related reasons:
Additionally, an „OFF2“ or „OFF3“ command must be parameterized at the terminal strip/PMU, as otherwise the converter cannot be shutdown with a a defined command, when communications fail!

5.1.1 Control word display using the 7-segment display on the PMU

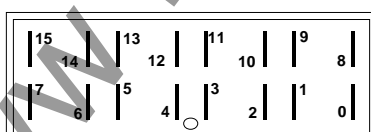

Control word 1

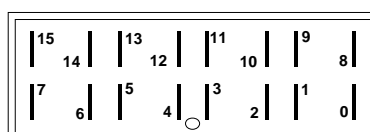

Control word 2

5.1.2 Control word 1 (Visualization parameter r550 or r967)

The factory setting is only valid for P077 = 0.

Designation Bit No. (Significance)	Value High / Low (1 = High, 0 = Low)				Parameter No. BAS (RES)	Fact. setting. BAS (RES) (P077 = 0)	Source selection see 5.1.4		
ON / OFF1 (Stop)	ON		OFF1		P554.1 (2)	1010 (1001)	Tab. X,A		
0	1	0							
OFF2 (electrical)	ON		OFF2		&	P555.1 (2) < 0001 (1002)	Tab. X,B		
1	1	0		P556.1 (2) < 0001 (0001)				Tab. X,B	
				P557.1 (2) < 0001 (0001)				Tab. X,B	
OFF3 (fast stop)	ON		OFF3		&	P558.1 (2) < 0001 (0001)	Tab. X,B		
2	1	0		P559.1 (2) < 0001 (0001)				Tab. X,B	
				P560.1 (2) < 0001 (0001)				Tab. X,B	
Inverter enable	Inverter enable		Inhibit inverter		P561.1 (2)	0001 (0001)	Tab. X,F		
3	1	0							
RFG enable	RFG enable		Inhibit RFG		P562.1 (2)	0001 (0001)	Tab. X,F		
4	1	0							
Start RFG	Start RFG		RFG stop		P563.1 (2)	0001 (0001)	Tab. X,F		
5	1	0							
Setpoint enable	Setpoint enable		Inhibit setpoint		P564.1 (2)	0001 (0001)	Tab. X,F		
6	1	0							
Acknowledge	ON				P565.1 (2) < 0000 (1003)	0000 (1003)	Tab. X,C		
7								P566.1 (2) < 0000 (0000)	Tab. X,C
								P567.1 (2) < 2001 (2001)	Tab. X,C
								1010 (fixed)	
Inching 1 / 2	Unchanged	Freq. 2	Freq. 1	No inching	P568.1 (2)	0000 (0000)	Tab. X,C		
8	1	0	1	0					
9	1	1	0	0	P569.1 (2)	0000 (0000)	Tab. X,C		
Control from the PLC	Control		no control		≥1	SST1/2	CB / TB		
10	1	0		SCB 2					
Enable rot. field	Both enab.	ccw ph seq	cw ph seq	No ph seq	P571.1 (2)	0001 (0001)	Tab. X,E		
11	1	0	1	0					
12	1	1	0	0	P572.1 (2)	0001 (0001)	Tab. X,E		
Motor potentiometer	Stop	Raise	Lower	Stop	P573.1 (2)	1010 (0000)	Tab. X,A		
13	0	1	0	1					
14	0	0	1	1	P574.1 (2)	1010 (0000)	Tab. X,A		
Fault, external 1	No fault		Fault, external 1		P575.1 (2)	0001 (0001)	Tab. X,D		
15	1	0							

5.1.3 Control word 2 (Visualization parameter r551)

The factory setting is only valid for P077 = 0.

Designation Bit No. (Significance)	Value High / Low (1 = High, 0 = Low)				Parameter No. BAS (RES)	Fact. setting. BAS (RES) (P077 = 0)	Source selection see 5.1.4
	SDS 4	SDS 3	SDS 2	SDS 1			
Setpoint data set	SDS 4	SDS 3	SDS 2	SDS 1			
16	1	0	1	0	P576.1 (2) <	< 0000 (0000)	< Tab. X,I
17	1	1	0	0	P577.1 (2) <	< 0000 (0000)	< Tab. X,I
Motor data set	MDS 4	MDS 3	MDS 2	MDS 1			
18	1	0	1	0	P578.1 (2) <	< 0000 (0000)	< Tab. X,I
19	1	1	0	0	P579.1 (2) <	< 0000 (0000)	< Tab. X,I
Fixed setpoint	FS 4	FS 3	FS 2	FS 1			
20	1	0	1	0	P580.1 (2) <	< 0000 (1004)	< Tab. X,I
21	1	1	0	0	P581.1 (2) <	< 0000 (0000)	< Tab. X,I
Synchronizing	Sync. enable		Sync. inhibit				
22	1		0		P582.1 (2) <	< 0000 (0000)	< Tab. X,I
Restart-on-the-fly	Enable		Inhibit				
23	1		0		P583.1 (2) <	< 0000 (0000)	< Tab. X,I
Droop/tech. contr.	Enable		Inhibit				
24	1		0		P584.1 (2) <	< 0000 (0000)	< Tab. X,I
Controller enable	Enable		Inhibit				
25	1		0		P585.1 (2) <	< 0001 (0001)	< Tab. X,I
Fault, external 2	No fault		Fault, external 2				
26	1		0		P586.1 (2) <	< 0001 (0001)	< Tab. X,G
Master/slave drive	Slave drive (M contr.)		Master drive (n contr.)				
27	1		0		P587.1 (2) <	< 0000 (0000)	< Tab. X,I
Alarm, external 1	No alarm		Alarm, external 1				
28	1		0		P588.1 (2) <	< 0001 (0001)	< Tab. X,G
Alarm, external 2	No alarm		Alarm, external 2				
29	1		0		P589.1 (2) <	< 0001 (0001)	< Tab. X,G
Basic/reserve	Reserve setting		Basic setting				
30	1		0		P590 <	< 1005	< Tab. X,I
HS checkback sig.	HS checkback sig.		No HS checkb. sig.				
31	1		0		P591 <	< 0001	< Tab. X,H

5.1.4 Selecting the source for control words 1 and 2

Table X (external pins)

1001	BE1 Pin -X101:16
1002	BE2 Pin -X101:17
1003	BE3 Pin -X101:18
1004	BE4 Pin -X101:19
1005	BE5 Pin -X101:20
1006	BE6 Pin -X101:21
1007	BE7 Pin -X101:22
4101	SCI, Slave1, Pin 01
4102	SCI, Slave1, Pin 02
4103	SCI, Slave1, Pin 03
4104	SCI, Slave1, Pin 04
4105	SCI, Slave1, Pin 05
4106	SCI, Slave1, Pin 06
4107	SCI, Slave1, Pin 07
4108	SCI, Slave1, Pin 08
4109	SCI, Slave1, Pin 09
4110	SCI, Slave1, Pin 10
4111	SCI, Slave1, Pin 11
4112	SCI, Slave1, Pin 12
4113	SCI, Slave1, Pin 13
4114	SCI, Slave1, Pin 14
4115	SCI, Slave1, Pin 15
4116	SCI, Slave1, Pin 16
4201	SCI, Slave2, Pin 01
4202	SCI, Slave2, Pin 02
4203	SCI, Slave2, Pin 03
4204	SCI, Slave2, Pin 04
4205	SCI, Slave2, Pin 05
4206	SCI, Slave2, Pin 06
4207	SCI, Slave2, Pin 07
4208	SCI, Slave2, Pin 08
4209	SCI, Slave2, Pin 09
4210	SCI, Slave2, Pin 10
4211	SCI, Slave2, Pin 11
4212	SCI, Slave2, Pin 12
4213	SCI, Slave2, Pin 13
4214	SCI, Slave2, Pin 14
4215	SCI, Slave2, Pin 15
4216	SCI, Slave2, Pin 16
5001	TSY, Pin 1

Table A

0000	constant value 0
1010	PMU
2001	SST1 word 1
3001	CB/TB word 1
4501	SCB1/2 peer-to-peer, SCB2 USS, word 1
4502	SCB1/2 peer-to-peer, word 2
4503	SCB1/2 peer-to-peer, word 3
4504	SCB1/2 peer-to-peer, word 4
4505	SCB1/2 peer-to-peer, word 5
6001	SST2 word 1

Table B

0001	constant value 1
1010	PMU
2001	SST1 word 1
3001	CB/TB word 1
4501	SCB1/2 peer-to-peer, SCB2 USS, word 1
4502	SCB1/2 peer-to-peer, word 2
4503	SCB1/2 peer-to-peer, word 3
4504	SCB1/2 peer-to-peer, word 4
4505	SCB1/2 peer-to-peer, word 5
6001	SST2 word 1

Table C

0000	constant value 0
2001	SST1 word 1
3001	CB/TB word 1
4501	SCB1/2 peer-to-peer, SCB2 USS, word 1
4502	SCB1/2 peer-to-peer, word 2
4503	SCB1/2 peer-to-peer, word 3
4504	SCB1/2 peer-to-peer, word 4
4505	SCB1/2 peer-to-peer, word 5
6001	SST2 word 1

Table D

0001	constant value 1
2001	SST1 word 1
3001	CB/TB word 1
4501	SCB1/2 peer-to-peer, SCB2 USS, word 1
4502	SCB1/2 peer-to-peer, word 2
4503	SCB1/2 peer-to-peer, word 3
4504	SCB1/2 peer-to-peer, word 4
4505	SCB1/2 peer-to-peer, word 5
6001	SST2 word 1

Table E

0000	constant value 0
0001	constant value 1
1010	PMU
2001	SST1 word 1
3001	CB/TB word 1
4501	SCB1/2 peer-to-peer, SCB2 USS, word 1
4502	SCB1/2 peer-to-peer, word 2
4503	SCB1/2 peer-to-peer, word 3
4504	SCB1/2 peer-to-peer, word 4
4505	SCB1/2 peer-to-peer, word 5
6001	SST2 word 1

Table I

0000	constant value 0
0001	constant value 1
2004	SST1 word 4
3004	CB/TB word 4
4501	SCB1/2 peer-to-peer, word 1
4502	SCB1/2 peer-to-peer, word 2
4503	SCB1/2 peer-to-peer, word 3
4504	SCB1/2 peer-to-peer, SCB2 USS, word 4
4505	SCB1/2 peer-to-peer, word 5
6004	SST2 word 4

Table F

0000	constant value 0
0001	constant value 1
2001	SST1 word 1
3001	CB/TB word 1
4501	SCB1/2 peer-to-peer, SCB2 USS, word 1
4502	SCB1/2 peer-to-peer, word 2
4503	SCB1/2 peer-to-peer, word 3
4504	SCB1/2 peer-to-peer, word 4
4505	SCB1/2 peer-to-peer, word 5
6001	SST2 word 1

Table G

0001	constant value 1
2004	SST1 word 4
3004	CB/TB word 4
4501	SCB1/2 peer-to-peer, word 1
4502	SCB1/2 peer-to-peer, word 2
4503	SCB1/2 peer-to-peer, word 3
4504	SCB1/2 peer-to-peer, SCB2 USS, word 4
4505	SCB1/2 peer-to-peer, word 5
6004	SST2 word 4

Table H

0001	No HS checkback sig.
4501	SCB1/2 peer-to-peer, word 1
4502	SCB1/2 peer-to-peer, word 2
4503	SCB1/2 peer-to-peer, word 3
4504	SCB1/2 peer-to-peer, word 4
4505	SCB1/2 peer-to-peer, word 5

5.1.5 Significance of control word- (1 and 2) commands

The operating statuses can be read in monitoring parameter r001: e.g. READY-TO-POWER-UP: r001=009.

The function sequences are described in the sequence in which they are realized.

Bit 0: ON / OFF1 command (↑ „ON“) / (L „OFF1“)

The command is executed with a positive edge change from L to H (L → H) only in the READY-TO-SWITCH-ON (009).

- Folge:
- ◆ PRE-CHARGING (010)
Main contactor/bypass contactor (option) are switched-in, if present
Pre-charging is realized
 - ◆ READY STATUS (011)
If the unit was last powered on using „OFF2“, the drive converter only changes over into the next status after the de-energization time (P371) since the last shutdown instant.
 - ◆ GROUND FAULT TEST (012), only for selected ground-fault test (P354).
 - ◆ RESTART-ON-THE-FLY (013), if restart-on-the-fly (control word bit 23 via P583) is enabled.
 - ◆ READY (014).

LOW signal and P163 = 3, 4 (f- /n control)

- Result:
- ◆ OFF1 (015), if the unit is in a status with inverter enable.
 - For P163 = 3, 4 and slave drive, there is a delay until the higher-level open-/closed-loop control shuts down the drive.
 - For P163 = 3, 4 and master drive, the setpoint at the ramp-function generator input is inhibited (setpoint = 0), so that the drive decelerates along the parameterized down ramp (P464) to the OFF shutdown frequency (P514).

After the OFF delay time has expired (P516), the inverter pulses are inhibited, and the main contactor, if available, is opened. If the OFF1 command is again withdrawn during ramp-down (e.g. using an ON command), deceleration is interrupted, and the drive goes into the „RUN (014) status.

- ◆ The inverter pulses are inhibited, and the main contactor, if available, opened for PRECHARGING (010), READY (011), RESTART-ON-THE-FLY (013) or MOT-ID STANDSTILL (018).
- ◆ SWITCH-ON INHIBIT (008)
- ◆ SWITCH-ON INHIBIT (009), if „OFF2“ or „OFF3“ is not present.

LOW signal and P163 = 5 (closed-loop torque control)

- Result:
- ◆ An OFF2 command (electrical) is output.

Bit 1: OFF2 command (L „OFF2“) (electrical)

LOW signal

- Result:
- ◆ The inverter pulses are inhibited, and the main contact, if available, opened.
 - ◆ SWITCH-ON INHIBIT (008), until the command is withdrawn.

NOTE

The **OFF2** command is simultaneously effective from three sources (P555, P556 and P557)!

Bit 2: OFF3 command (L „OFF3“) (fast stop)

LOW signal

Result: ♦ This command has two possible effects:

- DC braking is enabled (P372 = 1):
DC braking (017)
The drive decelerates along the parameterized down ramp for OFF3 (P466), until it reaches the start of DC braking frequency (P375).
The inverter pulses are then inhibited for the duration of the de-energization time (P371).
DC current braking is then realized with an adjustable braking current (P373) with a braking time which can be parameterized (P374).
The inverter pulses are then inhibited, and the main contactor, if available, is opened.
 - DC braking is not enabled (P372 = 0):
The setpoint is inhibited at the ramp-function generator input (setpoint = 0), so that the drive decelerates along the parameterized downramp for OFF3 (P466) to the OFF shutdown frequency (P514).
After the OFF delay time (P516) has expired, the inverter pulses are inhibited, and the main/bypass contactor, if available, is opened.
If the OFF 3 command is again withdrawn during deceleration, the drive still continues to decelerate.
☞ Section 6.6 „Ramp-function generator“
- ♦ The inverter pulses are inhibited, and the main/bypass contactor, if available, is opened for PRECHARGING (010), READY (011), RESTART-ON-THE-FLY (013) or MOT-ID STANDSTILL (018).
 - ♦ If the drive operates as slave drive, then it automatically switches-over to master drive, for an OFF3 command.
 - ♦ SWITCH-ON INHIBIT (008), until the command is withdrawn.

NOTE

- ♦ The **OFF 3** command is simultaneously effective from three sources (P558, P559 und P560)!
- ♦ Priority of the **OFF** commands: **OFF2 > OFF3 > OFF1**

Bit 3: Inverter enable command (H „inverter enable“) / (L „inverter inhibit“)

HIGH signal, READY (011) and expiration of the de-energization time (P371) since the last shutdown instant.

Result: ♦ RUN (014)

The inverter pulses are enabled, and the setpoint is approached via the ramp-function generator.

LOW signal

- ♦ For RESTART-ON-THE-FLY (013), RUN (014), KINETIC BUFFERING with pulse enable, SPEED CONTROLLER LOOP OPTIMIZATION (019) or SYNCHRONIZING (020):
Changeover into the READY (011) status, the inverter pulses are inhibited.
- ♦ For OFF1 (015 / stop), the inverter pulses are inhibited, the main contact, if available, opens, and the drive converter changes over into the SWITCH-ON INHIBIT status (008).
- ♦ For OFF3 (016 / fast stop), the inverter inhibit command is ignored, and fast stop is continued.

Bit 4: Ramp-function generator inhibit command (L „inhibit ramp-function generator“)

LOW signal in the RUN (014) status.

Result: ♦ The ramp-function generator output is set to setpoint = 0.

Bit 5: Ramp-function generator stop command (L „ramp-function generator stop“)

LOW signal in the RUN status (014).

Result: ♦ The actual setpoint is frozen at the ramp-function generator output.

Bit 6: Setpoint enable command (H „setpoint enable“)

HIGH signal and expiration of the de-energization time (P189).

Result: ♦ The setpoint at the ramp-function generator input is enabled.

Bit 7: Acknowledge command (↑ „Acknowledge“)

Positive edge change from (L → H) in the FAULT status (007).

Result: ♦ All of the actual faults are deleted after they have been previously transferred into the diagnostics memory.

- ♦ SWITCH-ON INHIBIT (008), if no actual faults exist.
- ♦ FAULT (007), if additional actual faults exist.

NOTE

The **acknowledge** command is simultaneously effective from three sources (P565, P566 und P567) and always from the PMU!

Bit 8: Inching 1 ON command (↑ „Inching 1 ON“) / (L „Inching 1 OFF“)

Positive edge change from L to H (L → H) in the READY TO SWITCH-ON status (009).

Result: ♦ An ON command (refer to control word, bit 0) is issued, and the inching frequency 1 (P448) is enabled in the setpoint channel.
The ON/OFF1 command (bit 0) is ignored for active inching operation.

LOW signal

Result: ♦ An OFF1 command (refer to control word bit 0) is automatically issued.

Bit 9: Inching 2 ON command (↑ „Inching 2 ON“) / (L „Inching 2 OFF“)

Positive edge change from L to H (L → H) in the READY TO SWITCH-ON (009) status.

Result: ♦ An ON command (refer to control word bit 0) is issued, and inching frequency 2 (P449) is enabled in the setpoint channel.
The ON/OFF1 command (bit 0) is ignored for active inching operation.

LOW signal

Result: ♦ An OFF1 command (refer to control word bit 0) is automatically issued.

Bit 10: Control from the PLC command (H „control from the PLC“)

HIGH signal; Process data PZD (control word, setpoints) which were sent via the SST1 interface of CU, the CB/TB interface (option) and the SST/SCB interface (option), are only evaluated if the command was accepted.

- Result:
- ◆ If several interfaces are operational, only the process data of the interfaces are evaluated, which transmit the H signal.
 - ◆ For an L signal, the last values are retained in the appropriate dual port RAM of the interface.

NOTE

An H signal appears in the visualization parameter r550 „control word 1“, if **one** of the interfaces transmits an H signal!

Bit 11: Clockwise phase sequence command (H „clockwise phase sequence“)

HIGH signal

- Result: ◆ The setpoint is influenced in conjunction with bit 12 „counter-clockwise rotating field“.

☞ Chapter 10 „Function diagram, setpoint channel CU (Section 2)“

Bit 12: Counter-clockwise phase sequence command (H „counter-clockwise phase sequence“)

HIGH signal

- Result: ◆ The setpoint is influenced in conjunction with bit 11 „clockwise rotating field“.

☞ Chapter 10 „Function diagram, setpoint channel CU (Section 2)“

NOTE

The **counter-clockwise phases sequence** and **clockwise phase sequence** commands have no influence on supplementary setpoint 2, which is added after the ramp-function generator!

Bit 13: Motorized potentiometer, raise command (H „raise motorized potentiometer“)

HIGH signal

- Result: ◆ The motorized potentiometer in the setpoint channel is energized in conjunction with bit 14 „motorized potentiometer, lower“.

☞ Chapter 10 „Function diagram, setpoint channel CU (Section 1)“

Bit 14: Motorized potentiometer, lower command (H „motorized potentiometer, lower“)

HIGH signal

- Result: ◆ The motorized potentiometer in the setpoint channel is energized in conjunction with bit 13 „motorized potentiometer, raise“.

☞ Chapter 10 „Function diagram, setpoint channel CU (Section 1)“

Bit 15: Fault, external 1 command (L „fault, external 1“)

LOW signal

Result: ♦ FAULT (007) and fault message (F035).
The inverter pulses are inhibited and the main contactor, if available, is opened.

☞ Chapter 12 „Fault and alarm messages“

Bit 16: Setpoint channel data set SDS bit 0 command

Result: ♦ One of the four possible setpoint channel data sets are controlled in conjunction with bit 17 „SDS BIT 1“.

☞ Chapter 10 „Function diagram, setpoint channel CU (Part 1) / data sets“

Bit 17: Setpoint channel data set SDS bit 1 command

Result: ♦ One of the four possible setpoint channel data sets are controlled in conjunction with bit 16 „SDS BIT 0“.

☞ Chapter 10 „Function diagram, setpoint channel CU (Part 1) / data sets“

Bit 18: Motor data set MDS bit 0 command

READY-TO-SWITCH-ON (009), PRECHARGING (010) or READY (011)

Result: ♦ One of the four possible motor data sets is controlled in conjunction bit 19 „MDS BIT 1“.

☞ Chapter 10 „Function diagram, data sets“

Bit 19: Motor data set MDS bit 1 command

READY-TO-SWITCH-ON (009), PRECHARGING (010) or READY (011)

Result: ♦ One of the four possible motor data sets is controlled in conjunction bit 18 „MDS BIT 0“.

☞ Chapter 10 „Function diagram, data sets“

Bit 20: Fixed setpoint FSW bit 0 (LSB command)

Result: ♦ One of the four possible fixed setpoints is controlled in conjunction with bit 21 „FSW BIT 1“.

☞ Chapter 10 „Function diagram, setpoint channel CU (Section 1) / data sets“

Bit 21: Fixed setpoint FSW bit 1 (MSB) command

Result: ♦ One of the four possible fixed setpoints is controlled in conjunction with bit 20 „FSW BIT 0“.

☞ Chapter 10 „Function diagram, setpoint channel CU (Section 1) / data sets“

Bit 22: Synchronizing enable command (H „Synchronizing enable“)

HIGH signal, TSY (option) present and P163 = 2 (V/f characteristic for textile applications).

Result: ♦ The command enables the synchronizing function.

☞ Operating Instructions for TSY (option).

Bit 23: Restart-on-the-fly enable command (H „enable restart-on-the-fly“)

HIGH-Signal

Folge: ♦ This command enables the restart-on-the-fly function.

☞ Chapter 9 „Functions (software)“

Bit 24: Droop/technology controller enable command (H „droop/technology controller enable“)

HIGH- signal

Result: ♦ This command has two different functions:

- The command enables the droop function if P163 „Control Mode“ is assigned 3 „closed-loop frequency control“ or 4 „closed-loop speed control“, parameter P248 \neq 0 and the converter inverter pulses are enabled.
The n/f controller output, which is negatively fed back to the n/f setpoint, can be set via parameters P247 „droop“ and P248 „droop Kp“.
- The command activates the technology controller if the inverter pulses are enabled and the excitation time has expired. The technology controller can be parameterized using parameters P525 to P545.

☞ Chapter 10 „Function diagrams, closed-loop control“ and Chapter 11 „Parameter list“

NOTE

If only one of the two functions is to be activated, it must be ensured that the other is disabled. Droop is disabled with P248 = 0 and the technology controller with P526 = 0000. Both functions are disabled as default setting.

Bit 25: Controller enable command (H „controller enable“)

HIGH signal and the drive converter inverter pulses enabled.

Result: ♦ The n-controller output for the appropriate control type (P163 = 0,4,5) is enabled.

☞ Chapter 10 „Function diagrams, closed-loop control“

Bit 26: Fault, external 2 command (L „fault, external 2“)

LOW signal; only activated from the READY status (011) with an additional time delay of 200 ms.

Result: ♦ FAULT (007) and fault message (F036).

The inverter pulses are inhibited, the main contactor, if available, is opened.

☞ Chapter 12 „Fault and alarm messages“

Bit 27: Master/slave drive command (H „slave drive“/L „master drive“)

HIGH signal, P163 (open-loop/closed-loop control type) = 3, 4 (closed-loop frequency/speed control) and the drive converter inverter pulses enabled.

Result: ♦ Slave drive: The closed-loop control operates as a torque control (closed-loop torque control).

LOW signal, P163 (open-loop/closed-loop control type) = 3, 4 (closed-loop frequency/speed control) and the drive converter inverter pulses enabled.

Result: ♦ Master drive: The closed-loop control operates as a speed or frequency control (closed-loop speed/frequency control).

☞ Chapter 10 „Function diagrams, closed-loop speed control“

Bit 28: Alarm, external 1 command (L „alarm, external 1“)

LOW signal

Result: ♦ The operating status is retained. An alarm message (A015) is output.

☞ Chapter 12 „Fault and alarm messages“

Bit 29: Alarm, external 2 command (L „alarm, external 2“)

LOW-Signal

Result: ♦ The operating status is retained. An alarm message (A016) is output.

☞ Chapter 12 „Fault and alarm messages“

Bit 30: Selection, reserve/basic setting command (H „reserve setting“) / (L „basic setting“)

HIGH signal

Folge: ♦ The parameter settings of the reserve setting for the control word itself, the setpoint channel, and the closed-loop control are activated.

LOW signal

Result: ♦ The parameter settings of the basic setting for the control word itself, the setpoint channel, and the closed-loop control are activated.

☞ Chapter 10 „Function diagrams, data sets“

Bit 31: HS checkback signal command (H „HS checkback signal“)

HIGH signal, corresponding to the configuration (wiring) and parameterization of the main contactor (option).

Result: ♦ Checkback signal, „main contactor energized“.

☞ Chapter „Options“ in Operating Instructions, Part 1

5.2 Status word

Introduction and application example

Status words are process data in the sense of the explanation in Section 3.2.

A „destination“ can be parameterized for every bit of a status word, which can be identified by the bit status (binary outputs of the CU, SCI 1/2 terminals, TSY terminals).

A parameter is available to „connect-up“ the destination for each status bit.

The selection parameters are indexed three times as follows:

- Index i001 Selecting a terminal on the CU / PEU board (basic drive converter)
- Index i002 Selecting a terminal on the SCI 1/2 board (option)
- Index i003 Selecting a terminal on the TSY board (option)

Example for connecting-up the destination:

The „ramp-function generator active“ signal (status word 1, bit 13), is to be connected-up as high-active signal at binary output 2 (BA2) of CU (terminal -X100:6/7) :

- ◆ The status bit „connection“ to binary output of the CU is parameterized via index i001.
- ◆ From the status word 1 table, it can be identified that the „ramp-function generator active“ signal is assigned to parameter P613.
- ◆ The parameter value for the required destination is searched for in the same table. The result is 1002 for binary output 2 of the CU.
- ◆ This parameter value must now be entered into parameter P613.1.

Bit #	Significance	Parameter	Parameter value	Required destination connection
Bit 13	Ramp-function generator active	P613.1	> 1002	BA2 terminal -X100:6/7

For a high signal at terminal -X100:6/7, the ramp-function generator is active; it is inactive for a low signal.

If a value, which is assigned a terminal (binary output BA), is assigned once in a select parameter for a destination, then it is no longer available in the same index of another select parameter, as a terminal is only suitable to output one status bit.

INFORMATION

Faults, alarms and power-on inhibit (HIGH active), are displayed via the terminal strip (binary outputs) as LOW active.

This is also valid for possible option boards!

☞ Section 6.2 „Binary outputs“

5.2.1 Status word 1 (visualization parameter r552 or r968)

PMU display

„Status word 1“

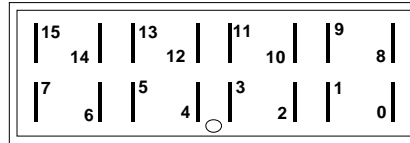

Bit #	Value	1 = High 0 = Low	Select dest.		Value	Destination
Bit 0	1	Ready-to-switch-on	P600.x	x = 1	0000	No destination
	0	Not ready to switch on			1001	BA1, -X9:4/5
Bit 1	1	Ready	P601.x		1002	BA2, -X100:6/7/8
	0	Not ready			1003	BA3, -X100:9/10
Bit 2	1	Run	P602.x		1004	BA4, -X100:11/12
	0	Inverter pulses inhibited				
Bit 3	1	Fault	P603.x	x = 2	0000	No destination
	0	No fault			4101	SCI 1/2, slave 1, BA1
Bit 4	1	No OFF 2	P604.x		4102	SCI 1/2, slave 1, BA2
	0	OFF2			4103	SCI 1/2, slave 1, BA3
Bit 5	1	No OFF 3	P605.x		4104	SCI 1/2, slave 1, BA4
	0	OFF3			4105	SCI 1/2, slave 1, BA5
Bit 6	1	Switch-on inhibit	P606.x		4106	SCI 1/2, slave 1, BA6
	0	No switch-on inhibit			4107	SCI 1/2, slave 1, BA7
Bit 7	1	Alarm	P607.x		4108	SCI 1/2, slave 1, BA8
	0	No alarm			4109	only SCI 2, slave 1, BA9
Bit 8	1	No setpt. act. val. deviation	P608.x		4110	only SCI 2, slave 1, BA10
	0	Setpt. act. value deviation			4111	only SCI 2, slave 1, BA11
Bit 9	1	PZD control requested.	always 1		4112	only SCI 2, slave 1, BA12
	0	(not permissible)			4201	SCI 1/2, slave 2, BA1
Bit 10	1	Comparison freq. reached	P610.x		4202	SCI 1/2, slave 2, BA2
	0	Actual val. < comparative freq.			4203	SCI 1/2, slave 2, BA3
Bit 11	1	Fault, undervoltage	P611.x	4204	SCI 1/2, slave 2, BA4	
	0	No undervoltage fault		4205	SCI 1/2, slave 2, BA5	
Bit 12	1	Main contactor energized	P612.x	4206	SCI 1/2, slave 2, BA6	
	0	Main contactor not energized		4207	SCI 1/2, slave 2, BA7	
Bit 13	1	HLG active	P613.x	4208	SCI 1/2, slave 2, BA8	
	0	HLG not active		4209	only SCI 2, slave 2, BA9	
Bit 14	1	Clockwise phase sequence	P614.x	4210	only SCI 2, slave 2, BA10	
	0	Counter-clockwise phase seq.		4211	only SCI 2, slave 2, BA11	
Bit 15	1	KIP/FLN active	P615.x	4212	only SCI 2, slave 2, BA12	
	0	KIP/FLN not active				
				x = 3	0000	No destination
					5001	TSY, BA1
					5002	TSY, BA2

5.2.2 Status word 2 (visualization parameter r553)

PMU display

„Status word 2“

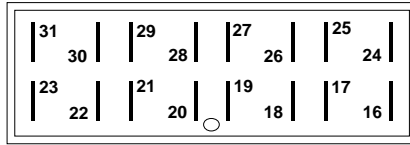

com

Bit #	Value	1 = High 0 = Low	Select dest.		Value	Destination
Bit 16	1	Restart-on-the-fly or excit. active	P616.x	x = 1	0000	No destination
	0	Restart-on-the-fly + excit. inactive			1001	BA1, -X9:4/5
Bit 17	1	Synchronism reached	P617.x		1002	BA2, -X100:6/7/8
	0	Synchronism not reached			1003	BA3, -X100:9/10
Bit 18	1	No overspeed	P618.x	1004	BA4, -X100:11/12	
	0	Overspeed				
Bit 19	1	Fault, external 1	P619.x	x = 2	0000	No destination
	0	No fault, external 1			4101	SCI 1/2, slave 1, BA1
Bit 20	1	Fault, external 2	P620.x		4102	SCI 1/2, slave 1, BA2
	0	No fault, external 2			4103	SCI 1/2, slave 1, BA3
Bit 21	1	Alarm, external	P621.x		4104	SCI 1/2, slave 1, BA4
	0	No alarm, external			4105	SCI 1/2, slave 1, BA5
Bit 22	1	Alarm i2t converter	P622.x		4106	SCI 1/2, slave 1, BA6
	0	No alarm, i2t converter			4107	SCI 1/2, slave 1, BA7
Bit 23	1	Fault, overtemp., converter	P623.x		4108	SCI 1/2, slave 1, BA8
	0	No fault, overtemp. conv.			4109	only SCI 2, slave 1, BA9
Bit 24	1	Alarm, overtemp., conv.	P624.x		4110	only SCI 2, slave 1, BA10
	0	No alarm, overtemp., conv.			4111	only SCI 2, slave 1, BA11
Bit 25	1	Alarm, motor overtemp.	P625.x		4112	only SCI 2, slave 1, BA12
	0	No alarm, overtemp. mot.			4201	SCI 1/2, slave 2, BA1
Bit 26	1	Fault, motor overtemp.	P626.x		4202	SCI 1/2, slave 2, BA2
	0	No fault, overtemp. mot.			4203	SCI 1/2, slave 2, BA3
Bit 27	1	T. contr. act. val.>T. contr. setp.	P627.x	4204	SCI 1/2, slave 2, BA4	
	0	T. contr. act. val.<T. contr. setp.		4205	SCI 1/2, slave 2, BA5	
Bit 28	1	Fault, motor stall/lock	P628.x	4206	SCI 1/2, slave 2, BA6	
	0	No fault motor stall/lock		4207	SCI 1/2, slave 2, BA7	
Bit 29	1	Bypass contactor energized	P629.x	4208	SCI 1/2, slave 2, BA8	
	0	Bypass contactor not energized		4209	only SCI 2, slave 2, BA9	
Bit 30	1	Alarm, synchronizing error	P630.x	4210	only SCI 2, slave 2, BA10	
	0	No alarm, synchronizing error		4211	only SCI 2, slave 2, BA11	
Bit 31	1	Pre-charging active	P631.x	4212	only SCI 2, slave 2, BA12	
	0	Pre-charging not active				
				x = 3	0000	No destination
					5001	TSY, BA1
					5002	TSY, BA2

5.2.3 Significance of the status word messages

Bit 0: Signal, „Ready to switch-on“ (H)

HIGH signal: SWITCH-ON INHIBIT (008) or READY-TO-SWITCH-ON (009) status

- Significance ♦ The power supply, the open-loop and closed-loop control are operational.
- ♦ The inverter impulses are inhibited.
 - ♦ If an external power supply and a main contactor (option) are available, it is possible that the DC link can be brought into a no-voltage condition in this converter status!

Bit 1: Signal, „ready“ (H)

HIGH signal: PRE-CHARGING (010) or READY (011) status

- Significance ♦ The power supply, the open-loop and closed-loop control are operational.
- ♦ The converter is switched-on.
 - ♦ Pre-charging is executed (has been completed).
 - ♦ The DC link is ramped-up to the full voltage (has attained full voltage).
 - ♦ The inverter pulses are still inhibited.

Bit 2: Signal, „run“ (H)

HIGH signal: RESTART-ON-THE-FLY (013), RUN (014), OFF1 (015) or OFF3 (016) status

- Significance ♦ The converter is functioning.
- ♦ The inverter pulses are enabled.
 - ♦ The output terminals are live.

Bit 3: Signal, „Fault“ (H)

HIGH signal: FAULT (007) status

- Significance ♦ A fault has occurred.

Output at the terminal strip (PEU, CU, TSY, SCI1/2) with L signal.

Bit 4: Signal, „OFF2“ (L)

LOW signal: OFF2 command present

- Significance ♦ The OFF2 command (control word bit 1) was output.

Bit 5: Signal, „OFF3“ (L)

LOW signal: OFF3 (016) status, and/or OFF3 command available

- Significance ♦ The OFF3 command (control word bit 2) was output.

Bit 6: Signal, „switch-on inhibit“ (H)

HIGH signal: SWITCH-ON INHIBIT (008) status

- Significance
- ◆ The power supply, open- and closed-loop control are operational.
 - ◆ If an external power supply and a main contactor (option) are available, it is possible that the DC link is in a no-voltage condition in this converter status!
 - ◆ The message is continuously available as long as an OFF2 command is present via the control word bit1; or/and an OFF3 command is available via the control word bit 2 after the setpoint has been reduced; or/and an ON command is still available via the control word bit 0 (edge evaluation).

Output at the terminal strip (PEU, CU, TSY, SCI1/2) with L signal.

Bit 7: Signal, „alarm“ (H)

HIGH signal: Alarm (Axxx)

- Significance
- ◆ An alarm has occurred.
 - ◆ The signal remains until the cause has been removed.

Output at the terminal strip (PEU, CU, TSY, SCI1/2) with L signal.

Bit 8: Signal, „setpoint-actual value deviation“ (L)

LOW signal: Alarm „setpoint-actual value deviation“ (A034)

- Significance
- ◆ The frequency actual value - frequency setpoint deviation is greater than P517 (Deviation Freq.) and remains for longer than the time parameterized in P518 (Deviation Time).
 - ◆ The bit is again set to an H signal if the deviation is less than the parameter value P517.

Bit 9: Signal, „PZD control requested“ (H)

HIGH signal: It is always present.

Bit 10: Signal, „comparison frequency reached“ (H)

HIGH signal: The parameterized comparison frequency has been reached.

- Significance
- ◆ The absolute frequency actual value is greater than or the same as the parameterized comparison frequency (P512).
 - ◆ The bit is again set to L, as soon as the actual absolute frequency value falls below the comparison frequency (P512), minus the parameterized comparison frequency hysteresis (P513 in % referred to the comparison frequency (P512)).

Bit 11: Signal, „fault, undervoltage“ (H)

HIGH signal: Fault „undervoltage in the DC link“ (F008)

- Significance
- ◆ The DC link voltage has fallen below the permissible limit value.
- ☞ Chapter 12 „Fault and alarm messages“

Output at the terminal strip (PEU, CU, TSY, SCI1/2) with L signal.

Bit 12: Signal, „main contactor energized“ (H)

HIGH signal: The main contactor is energized.

Significance ♦ A main contactor (option) can be controlled with the appropriate „wiring“ and parameterization.
 ⓘ Section „Options“ in Operating Instructions, Part 1

Bit 13: Signal, „RFG active“ (H)

HIGH signal: Ramp-function generator active

Significance ♦ The ramp-function generator output value (r480) is not equal to the ramp-function input value (r460).
 A hysteresis, which can be parameterized (P476 in %, referred to the rated system frequency P420) can only be taken into account for an analog setpoint input.

- ♦ When the „synchronizing“ function is selected, alarm A069 is initiated, as long as the ramp-function generator in the setpoint channel of the synchronizing drive converter is active. Synchronizing is not started as long as the ramp-function generator is active.

Bit 14: Signal, „clockwise phase sequence“ (H)/“ counter-clockwise phase sequence“ (L)

HIGH signal: Clockwise phase sequence

Significance ♦ The frequency setpoint for the closed-loop control (n/f setpoint, r482), is greater than or equal to 0).

LOW signal: Counter-clockwise phase sequence

Significance ♦ The frequency setpoint for the closed-loop control (n/f setpoint, r482) is less than 0.

Bit 15: Signal, „KIP/FLN active“ (H)

HIGH signal: The kinetic buffering (KIP) function or the flexible response (FLN) function is active.

Significance ♦ KIP: A brief supply failure is buffered using the kinetic energy of the machine.
 ♦ FLN: The drive converter can be operated down to a minimum DC link voltage of 50% of the rated value.
 ⓘ Chapter 9 „Functions“

Bit 16: Signal, „restart-on-the-fly active“ (H)

HIGH signal: The restart-on-the-fly function is active or the excitation time (P189) is running.

Significance ♦ The drive converter has been switched to a motor which is still rotating.
 ♦ An overcurrent condition is prevented using the restart-on-the-fly function.
 ⓘ Chapter 9 „Functions“
 ♦ The energization time is active.

Bit 17: Signal, „synchronism reached“ (H)

HIGH signal: Synchronism has been reached.

Significance ♦ Synchronism has been reached.
 ⓘ Instruction Manual for the TSY and Chapter 12 „Fault- and alarm messages“.

Prerequisite: TSY (option) available and P163 (open-loop/closed-loop control type) = 2 (V/f characteristic for textile application).

Bit 18: Signal, „overspeed“ (L)

LOW signal: Alarm „overspeed“ (A033)

Significance ♦ The frequency actual value is either:

- greater than the maximum frequency for a clockwise phase sequence (P452), plus a hysteresis (P519 in %, referred to P452) or
 - is less than the maximum frequency for the counter-clockwise phase sequence (P453) plus a hysteresis (P519 in %, referred to P453).
- ♦ The bit is again set to an H, as soon as the absolute frequency actual value is less than or equal to the absolute value of the appropriate maximum frequency.

Bit 19: Signal, „fault, external 1“ (H)

HIGH signal: „Fault, external 1“

Significance ♦ A „fault, external 1“ is present in control word bit 15.

Output at the terminal strip (PEU, CU, TSY, SCI1/2) with L signal.

Bit 20: Signal, „fault, external 2“ (H)

HIGH signal: „Fault, external 2“

Significance ♦ A „fault, external 2“ is present in control word bit 26.

Output at the terminal strip (PEU, CU, TSY, SCI1/2) with L signal.

Bit 21: Signal, „external alarm“ (H)

HIGH signal: „External alarm“

Significance ♦ An „external alarm 1“ is present in control word bit 28, or an „external alarm 2“ in control word bit 29.

Output at the terminal strip (PEU, CU, TSY, SCI1/2) with L signal.

Bit 22: Signal, „alarm i²t inv.“ (H)

HIGH signal: Alarm „i²t-Inv.“ (A025)

Significance ♦ If the instantaneous load status remains the same, then the drive converter will be thermally overloaded.

☞ Chapter 12 „Fault and alarm messages“

Output at the terminal strip (PEU, CU, TSY, SCI1/2) with L signal.

Bit 23: Signal, „Overtemperature fault signal UMR“ (H)

HIGH signal: „Inverter temperature too high“ fault (F023)

Significance ♦ The inverter temperature limit value was exceeded.

☞ Chapter 12 „Fault and alarm messages“

Output at the terminal strip (PEU, CU, TSY, SCI1/2) with L signal.

Bit 24: Signal, „motor overtemperature alarm“ (H)

HIGH signal: Alarm „inverter temperature too high“ (A022)

Significance ♦ Alarm temperature threshold of the inverter was exceeded.
 ⓘ Chapter 12 „Fault and alarm messages“

Output at the terminal strip (PEU, CU, TSY, SCI1/2) with L signal.

Bit 25: Signal, „motor overtemperature alarm“ (H)

HIGH signal: „Motor overtemperature“ alarm

Significance ♦ It involves an „motor I²t alarm“ (A029) or an overtemperature alarm using KTY (P360 > 0).
 ♦ The prerequisite for the alarm is the motor load calculation (r008) or by measurement using a KTY 84 sensor (r009).
 ♦ Parameters used in the calculation: P362 (Motor Cooling), P363 (Mot ThermT-Const), P364 (Mot. Load Limits).
 ⓘ Chapter 12 „Fault and alarm messages“

Output at the terminal strip (PEU, CU, TSY, SCI1/2) with L signal.

Bit 26: Signal, „motor overtemperature fault“ (H)

HIGH signal: High signal: „motor overtemperature“ fault

Significance ♦ It involves a „motor I²t fault“ (F021) or an overtemperature fault using KTY (P360 > 1) or PTC thermistor (P361 = 1).
 ⓘ Chapter 12 „Fault and alarm messages“

Output at the terminal strip (PEU, CU, TSY, SCI1/2) with L signal.

Bit 27: Signal, „technology controller actual value greater than technology controller setpoint“ (H)

HIGH signal: The technology controller actual value (r534) is greater than the technology controller setpoint (r529).

Significance ♦ The signal is set when the technology controller setpoint is exceeded.
 ♦ If the technology controller actual value becomes less than the technology controller setpoint, a hysteresis (P535) is also taken into account.

Bit 28: Signal, „motor stall“ (H)

HIGH signal: „Motor stalled or locked rotor“ fault (F015)

Significance ♦ The drive has either stalled or the rotor is locked.
 ⓘ Chapter 12 „Fault and alarm messages“

Output at the terminal strip (PEU, CU, TSY, SCI1/2) with L signal.

Bit 29: Signal, „bypass contactor energized“ (H)

HIGH signal: The bypass (pre-charging) contactor is energized (closed).

Significance ♦ A bypass contactor (option) can be energized (closed) with the appropriate wiring and parameterization.
 ⓘ Chapter „Options“ in Operating Instructions, Part 1

Bit 30: „Sync. error alarm“ signal (H)

HIGH signal: „Synchronizing error“ alarm (A070)

Significance ♦ After synchronization, the phase deviation is greater than the parameterized tolerance range (P391).

☞ Instruction Manual to TSY and Chapter 12 „Fault- and alarm messages“

Prerequisite: TSY (option) available and P163 (Control Mode) = 2 (V/f characteristic for textile applications).

Output at the terminal strip (PEU, CU, TSY, SC11/2) with L signal.

Bit 31: „Pre-charging active“ signal (H)

HIGH signal: PRE-CHARGING (010) status

Significance ♦ Pre-charging is executed after an ON command.

5.3 Setpoints

Introduction and application example

The setpoints are process data in the sense of the explanation in Section 3.2.

An individual source can be parameterized for every setpoint, from which the setpoint may be entered (fixed values, analog inputs, PMU, PZD part of the telegram from automation units).

The select parameters for the sources are indexed twice:

- Index i001: Basic setting (BASE)
- Index i002: Reserve setting (RES)

One parameter is available for the setpoints to „connect“ the source(s).

Example for connecting-up the sources:

The main setpoint should be „connected“ to analog input 1 of the CU (terminal -X102:27,28) as voltage input in the basic setting:

- ◆ From the setpoint table, it is possible to identify that the factory setting of parameter P443.1 of the main setpoint value is 1002
- ◆ In table B for the possible sources of the main setpoint, it can be seen that 1002 corresponds to the „motorized potentiometer“ source.
- ◆ In the setpoint table, it can be seen that the possible sources for the main setpoint are written into tables X, Y and B.
- ◆ The parameter value for the required source is searched for in tables X, Y and B. For analog input 1 of the CU, the value is found in Table X. The result is 1003.
- ◆ This parameter value must now be entered into parameter P443.1.

Designation	Parameter	Possible sources	Parameter value	Required source wiring
Main setpoint (GRD)	P443.1	Tab.X,Y,B	1003	AE1 terminal -X102:27,28,29

An amplification factor (P444.1) is available for parameter P443.1, which can be set as required.

		Gain	Normalization	Visualization
Speed controller gain adaption	P226	P227	4000Hex = 10	r228
Supplementary setpoint 1	P433	P434	4000Hex = P420	r437
Supplementary setpoint 2	P438	P439	4000Hex = P420	r442
Main setpoint	P443	P444	4000Hex = P420	r447
Torque setpoint	P486	P487	4000Hex = P485	r490
Upper torque limit	P493	P494	4000Hex = P485	r496
Lower torque limit	P499	P500	4000Hex = P485	r502
Torque/current supplementary setpoint	P506	P507	4000Hex = P485	r510
Technology controller setpoint	P526	P527	4000Hex = 100 %	r529
Technology controller actual value	P531	P532	4000Hex = 100 %	r534
Initial angle	P158	–	4000Hex = 90 %	r159, r160

Table 5.1 Interdependencies of the parameters for gain, normalization and visualization

5.3.1 Overview of the setpoints

Designation	Param. No.	Fac. setting	Possible sources	Gain	Fac. set.
	BAS (RES)	BAS (RES)		BAS (RES)	BAS+RE
Adaption of	P226.1 (2) <	<1001 (1001)	<Tab.X,A	P227.1 (2) <	<100.00
Supplementary setpoint 1	P433.1 (2) <	<0 (0)	<Tab.X,Y,A	P434.1 (2) <	<100.00
Supplementary setpoint 2	P438.1 (2) <	<0 (0)	<Tab.X,Y,A	P439.1 (2) <	<100.00
Main setpoint	P443.1 (2) <	<1002 (1001)	<Tab.X,Y,B	P444.1 (2) <	<100.00
Torque setpoint	P486.1 (2) <	<0 (0)	<Tab.X,C	P487.1 (2) <	<100.00
Upper torque limit	P493.1 (2) <	<1001 (1001)	<Tab.X,A	P494.1 (2) <	<100.00
Lower torque limit	P499.1 (2) <	<1001 (1001)	<Tab.X,A	P500.1 (2) <	<100.00
Suppl. torque/current setpoint	P506.1 (2) <	<0 (0)	<Tab.X,A	P507.1 (2) <	<100.00
Technology controller setpoint	P526.1 (2) <	<0 (0)	<Tab.X,Y,A	P527.1 (2) <	<100.00
Technology controller actual value	P531.1 (2) <	<0 (0)	<Tab.X,Y,D	P532.1 (2) <	<100.00
Initial angle	P158.1 (2) <	<0 (0)	<Tab.X,Y,C	–	–

Table 5.2 Setpoints

5.3.2 Selecting the possible setpoint sources

Table X

CU BOARD	
Value	Source
0000	Constant setpoint 0
1003	Analog input 1
1004	Analog input 2
2002	SST1 word 2
2003	SST1 word 3
2004	SST1 word 4 1)
...	Consecutively to
2016	SST1 word 16
6002	SST2 word 2
6003	SST2 word 3
6004	SST2 word 4 2)
...	Consecutively to
6016	SST2 word 16
OPTIONS	
Value	Source
3002	PT/CB word 2
3003	PT/CB word 3
3004	PT/CB word 4 3)
...	Consecutively to
3016	PT/CB word 16
4101	SCI1, slave1, AE1
4102	SCI1, slave1, AE2
4103	SCI1, slave1, AE3
4201	SCI1, slave2, AE1
4202	SCI1, slave2, AE2
4203	SCI1, slave2, AE3
4501	SCB1/2 (peer to peer) word 1 4)
4502	SCB1/2 (peer to peer, USS) word 2
4503	SCB1/2 (peer to peer, USS) word 3
4504	SCB1/2 (peer to peer, USS) word 4 5)
...	Consecutively to
4505	SCB1/2 (peer to peer, USS) word 5
4506	SCB2 (USS) word 6
...	Consecutively to
4516	SCB2 (USS) word 16

Table Y

CU BOARD	
Value	Source
2032	SST1 double word 2 and 3
2033	SST1 double word 3 and 4 1)
2034	SST1 double word 4 and 5 1)
...	Consecutively to
2045	SST2 double word 15 and 16
6032	SST2 double word 2 and 3
6033	SST2 double word 3 and 4 2)
6034	SST2 double word 4 and 5 2)
...	Consecutively to
6045	SST2 double word 15 and 16
OPTIONS	
Value	Source
3032	CB/TB double word 2 and 3
3033	CB/TB double word 3 and 4 3)
3034	CB/TB double word 4 and 5 3)
...	Consecutively to
3045	CB/TB double word 15 and 16
4531	SCB1/2 (peer to peer) word 1 and 2 4)
4532	SCB1/2 (USS, peer to peer) word 2 and 3
4533	SCB1/2 (USS, peer to peer) word 3 and 4 5)
4534	SCB1/2 (USS, peer to peer) word 4 and 5 5)
4535	SCB2 (USS) word 5 and 6
...	Consecutively to
4516	SCB2 (USS) word 15 and 16

Table A

Value	Source
1001	Fixed setpoint – for source P226: P225 – for source P433 and P438: P421 to P424 – for source P493: P492 – for source P499: P498 – for source P506: P505 – for source P526: P525
1020	Technology controller output

Table B

Value	Source
1001	Fixed setpoint (P421 to P424)
1002	Motorized potentiometer
1020	Technology controller output

Table C

Value	Source
1020	Technology controller output

Table D

Value	Source
1100	1: P530.1
1200	Technology controller act. val. 2: P530.2

- 1) only when word4 is not assigned for „control word2“ with 2004 (Section 5.1)
- 2) only if word4 is not assigned for „control word2“ with 6004 (Section 5.1)
- 3) only if word4 is not assigned for „control word2“ with 3004 (Section 5.1)
- 4) only if word1 is not assigned for „control word2“ with 4501 (Section 5.1)
- 5) only if word4 is not assigned for „control word2“ with 4504 (Section 5.1)

5.4 Actual values

Actual values are process data in the sense of the explanation in Section 3.2.

Four destinations are available in the basic version to output actual values.
Four additional output devices can be parameterized via option boards.

The contents of all available parameters of the basic drive converter can be selected as output values.

In order to connect a parameter to a destination, its parameter number must be entered in the selected destination parameter.

NOTES

- ◆ When selecting an indexed parameter, the value of the first index is always output!
- ◆ When entering a „0“ instead of a parameter number, an output is not made to the appropriate destination!

Destinations:

P530 „ActVal's ProcReg“
Output at the technology controller actual value input
Indices: i001 Value 1 for the technology controller actual value input (P531 = 1100)
i002 Value 2 for the technology controller actual value input (P531 = 1200)
☞ Chapter 10 „Function diagrams, closed-loop control“

P655 „CU AnaOut Act Val“
Output via the CU control terminal strip (Chapter 1)
Indices: i001 analog output 1 (-X102:34 / reference potential -X102:33)
i002 analog output 2 (-X103:44 / reference potential -X103:43)
☞ Section 6.4 „Analog outputs“

P680 „SCom1 Act Value“
P681 „SCom2 Act Value“
Output via the basic converter interfaces SST1 and/or SST2
Indices: i001 Word 01 of the telegram (PZD)
 ↓ ↓
 i016 Word 16 of the telegram (PZD)
☞ Section 6.5 „basic converter interfaces SST1 and SST2“

Destination, options:

P664 „SCI-AA actual values“
Output via the SCB1 interface with SCI1
☞ Instruction Manual for the option boards
Indexes: i001 Destination: Analog output 1 from slave 1
 i002 Destination: Analog output 2 from slave 1
 i003 Destination: Analog output 3 from slave 1
 i004 Destination: Analog output 1 from slave 2
 i005 Destination: Analog output 2 from slave 2
 i006 Destination: Analog output 3 from slave 2

P690 „SCB actual values“
Output via the SCB1 interface with peer-to-peer protocol or SCB2
☞ Instruction Manual for the option boards
Indexes: i001 Destination: Word 01 of the telegram (PZD)
 ↓ ↓
 i016 Destination: Word 16 of the telegram (PZD)

- P694** „CB/TB actual values“
 Output via the CB or TB interface
 ☞ Instruction Manual for the option boards and Sections 6.5.2 „DPR“
 Indices: i001 Destination: Word 01 of the telegram (PZD)
 ↓ ↓
 i016 Destination: Word 16 of the telegram (PZD)

NOTES

For telegram transfer (P680, P681, P690, P694):

- ◆ Generally, it is necessary/practical to assign „word 01 of the telegram (PZD)“ with the status word 1 (r968 or r552)!
- ◆ If double-word parameters (type I4) are to be transferred as actual values, the associated parameter number must be entered in 2 consecutive words (indices), as otherwise only the most significant word will be transferred!

Normalization:

The values of the parameters to be output are weighted with the normalization relationship specified in the parameter list.

For example, r004 (output current) is referred to 4 x P102 (Mot.curr(n)), i.e. 100 % corresponds to 400 % rated motor current.

Examples:

1) Technology controller

The output power (r005) of the control should be fed to the technology controller as second actual value.

P530.02 = 005

P531.01 = 1200 (basic setting)

2) Analog output

The speed setpoint (r482) should be output at analog output 2.

P655.02 = 482

3) SST1

Status word 1 (r968, r552) to word 1; speed setpoint (r482) to word 2 and 3 (double word, I4 parameter)

P680.01 = 968

P680.02 = 482

P680.03 = 482

6 Interfaces

6.1 Binary inputs

Seven binary inputs (24 V) which can be parameterized are available at the control terminal strip of board CU (-X101). These inputs can be used to input commands, external faults/alarms as well as checkback signal at the control word of the drive converter.

Connecting-up: ↗ Chapter 1 „Control terminal strip“.

Parameterization: ↗ Section 5.1 „Control word“.

Factory setting (valid for standby operation):

Binary input	Command		Control word bit	Parameter
	HIGH	LOW		
1	ON	OFF1	0	P554.2 = 1001 (reserve)
2	ON	OFF2 (electrical)	1	P555.2 = 1002 (reserve)
3	Acknowledge 		7	P565.2 = 1003 (reserve)
4	FSW-Bit 0 = 1	FSW-Bit 0 = 0	20	P580.2 = 1004 (reserve)
5	Reserve setting	Basic setting	30	P590 = 1005
6	not assigned			
7	not assigned			

Table 6.1 Binary inputs

6.2 Binary outputs

There are **four binary outputs which can be parameterized**.

These outputs can be used to output signals and external commands of the drive converter status word.

Connecting-up: Binary output 1 at the basic drive converter (connector -X9):
 ↳ Section „Auxiliary power supply / main contactor“ in Operating Instructions, Part 1
 Binary outputs 2 to 4 on the control terminal strip of the CU board (connector -X100):
 ↳ Chapter 1 „Control terminal strip“

Parameterization: ↳ Section 5.2 „Status word“.

Factory setting (not valid for cabinet units):

Binary output	Connector, location	Signal		Status-word bit	Parameter
		HIGH	LOW		
1	-X9	Main contactor energized	Main contactor not energized	12	P612.1 = 1001
2	-X100 on the CU	Fault	No fault	3	P603.1 = 1002
3	-X100 on the CU	Run	No operation	2	P602.1 = 1003
4	-X100 on the CU	Not assigned	Not assigned		

Table 6.2 Binary outputs

NOTE
<p>Faults, alarms and power-on inhibit (HIGH active) are displayed as LOW active via the terminal strip (binary outputs)</p> <p>↳ Section 5.2 „Status word“.</p>

6.3 Analog inputs

Control board CU has 2 analog inputs (AI), which can be used to input setpoints via voltage- or current signals or as speed actual value input (Connection ↗ Chapter 1).

Technical data:

Setpoint input via voltage	Setpoint via current	Speed actual value input
<ul style="list-style-type: none"> ◆ Input voltage range: <ul style="list-style-type: none"> • -10 V to +10 V • 0 V to +10 V • +2 V to +10 V ◆ Resolution 5 mV (11 bit + sign) ◆ Accuracy ± 0.5 % ◆ Stability at ΔT = 10 K: 0,2 % ◆ Smoothing 0 ms to 1000 ms, can be parameterized (P651) 	<ul style="list-style-type: none"> ◆ Input current range: <ul style="list-style-type: none"> • -20 mA to +20 mA • 0 mA to 20 mA • 4 mA to 20 mA ◆ Resolution 0,01 mA (11 bit + sign) ◆ Accuracy ± 0.7 % ◆ Stability at ΔT = 10 K: 0.2 % ◆ Smoothing 0 ms to 1000 ms, can be parameterized (P651) 	<ul style="list-style-type: none"> ◆ Input voltage range: ◆ ◆ -10 V to +10 V (use the ATI board for higher tachometer voltages!) ◆ Use a shielded cable and connect at one end to the drive converter.

Table 6.3 Technical data of the analog inputs

Using P208.x, it can be defined as to whether the analog input should be used as tachometer input (refer to Section 6.3.2).

P208.x	Analog input AE1	Analog input AE2
3	Analog tach. input	
4		Analog tach. input

Table 6.4 Speed feedback

6.3.1 Analog input as setpoint input

Signal flow for any setpoint; the overview of the possible setpoints is located in Section 5.3.1. (↗ Function diagrams „Analog inputs“, Chapter 10):

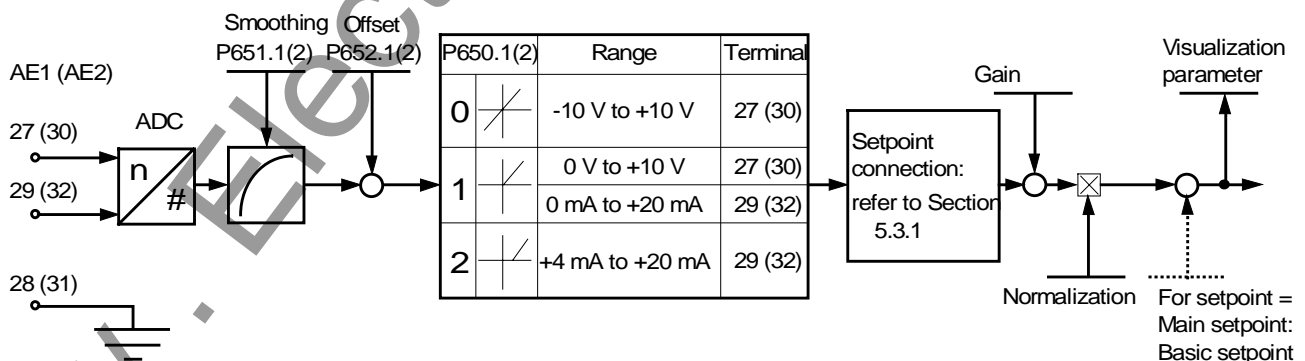

Fig. 6.1 Analog input as setpoint input

Parameters for gain, normalization and visualization belonging to a specific setpoint connection:

		Gain	Normalization	Visualization
Speed controller gain adaption	P226	P227	10 V = 10	r228
Supplementary setpoint 1	P433	P434	10 V = P420	r437
Supplementary setpoint 2	P438	P439	10 V = P420	r442
Main setpoint	P443	P444	10 V = P420	r447
Torque setpoint	P486	P487	10 V = P485	r490
Upper torque limit	P493	P494	10 V = P485	r496
Lower torque limit	P499	P500	10 V = P485	r502
Supplementary torque/current setpoint	P506	P507	10 V = P485	r510
Technology controller setpoint	P526	P527	10 V = 100 %	r529
Technology controller actual value	P531	P532	10 V = 100 %	r534
Initial angle	P158	–	10 V = 90 %	r159, r160

Table 6.5 Inter-relationships between parameters for gain, normalization and visualization

Parameterization:

- ◆ Connect the setpoint to the required analog input (e.g.: P443.1 = 1003: The main setpoint is connected to analog input 1 (basic setting)).
- ◆ P650.1(2) = Defines the input signal for analog input 1(2) (± 10 V, 0 to 10 V / 0 to 20 mA, 4 to 20 mA).

NOTE

For P650 = 2 (4 to 20 mA), setpoints < 2 mA result in a fault trip (wire breakage monitoring function)

- ◆ When required, change the smoothing time constant (P651.1).
- ◆ When required, adjust the zero point (offset adjustment) for setpoint input '0'. In this case, P652.1(2) is changed until the setpoint visualization parameter (corresponding to Table 6.5) is '0', e.g. r447.
- ◆ When required, set the gain (parameter according to Table 6.5) e.g. P444.

Calculating the gain using as an example, the main setpoint (including the basic setpoint):

Values X_1 to X_2 at the analog input should be represented at setpoints Y_1 to Y_2 .

- ◆ ± 10 V and 0 to 10 V:

$$P444.x = \frac{10 \text{ V}}{X_2 - X_1} \times \frac{Y_2 - Y_1}{P420} \times 100\%$$

$$P445.x = \frac{X_2 Y_1 - X_1 Y_2}{X_2 - X_1} \times \frac{1}{P420} \times 100\%$$

- ◆ 4 mA to 20 mA:

$$P444.x = \frac{16 \text{ mA}}{X_2 - X_1} \times \frac{Y_2 - Y_1}{P420} \times 100\%$$

$$P445.x = \frac{(X_2 - 4 \text{ mA}) \times Y_1 - (X_1 - 4 \text{ mA}) \times Y_2}{X_2 - X_1} \times \frac{1}{P420} \times 100\%$$

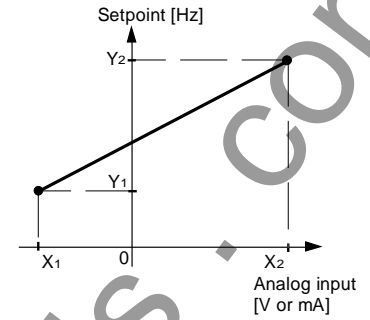

Fig. 6.2 Gain

Example of setpoint input via analog input:

In the basic setting, the main setpoint for motor data set 1 should be entered via analog input 1.

Setting range: 0 to 10 V should correspond to + 15 Hz to + 50 Hz.

Rated system frequency $P420 = 50$ Hz.

Parameterization:

- ◆ $P443.1 = 1003$ The basic setting for the main setpoint is connected to analog input 1.
- ◆ $P650.1 = 1$ The input voltage range for AE1 is set to 0 to 10 V
- ◆ $P651.1 = 4$ The smoothing time constant of AE1 is 4 ms (if required, change).
- ◆ $P652.1 = 0.000$ AE 1 does not have a zero point deviation. When required, change $P652.1$ until the main setpoint, $r447=0$, for setpoint input '0'.
- ◆ Set gain $P444.1$ and basic setpoint $P445.1$:

$$P444.1 = \frac{10 \text{ V}}{10 \text{ V} - 0 \text{ V}} \times \frac{50 \text{ Hz} - 15 \text{ Hz}}{50 \text{ Hz}} \times 100\% = 70\%$$

$$P445.1 = \frac{10 \text{ V} \times 15 \text{ Hz} - 0 \text{ V} \times 50 \text{ Hz}}{10 \text{ V} - 0 \text{ V}} \times \frac{1}{50 \text{ Hz}} \times 100\% = 30\%$$

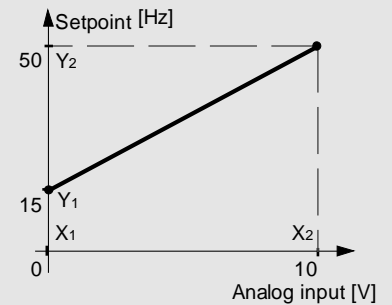

Fig. 6.3 Setpoint input via analog input

Example without offset ($P420 = 50$ Hz):

- ◆ $P445 = 0$
- ◆ Setting range ± 10 V \cong ± 50 Hz : $P444 = 100\%$
 ± 10 V \cong ± 100 Hz : $P444 = 200\%$

6.3.2 Analog input as speed actual value input

For drive converter output frequencies up to 100 Hz, an analog tachometer can be used for speed sensing. Generally, the ATI option is used as interface between the tachometer and board CU.

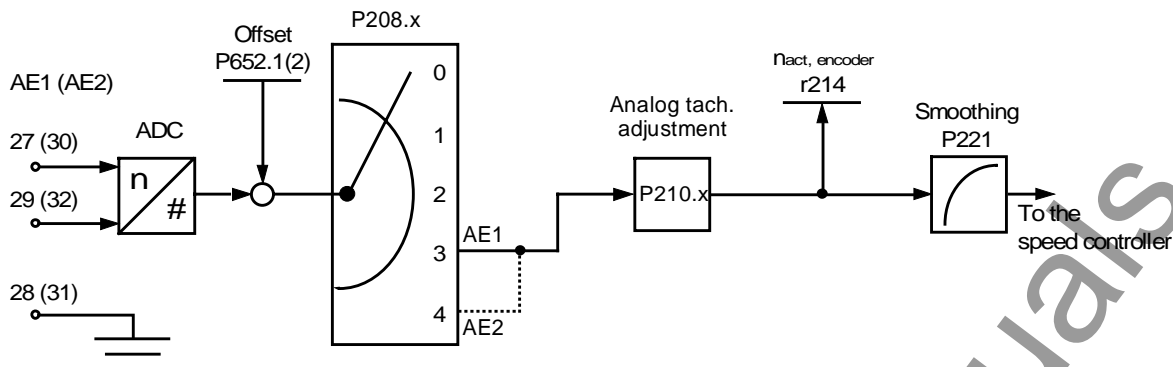

Fig. 6.4 Analog input as speed actual value input

Parameterization:

- ◆ P052 = 5 „Drive setting“ function
- ◆ P053 = 3 „Expert mode“ access stage
- ◆ P208.x = 3 The speed actual value is received via analog input 1, or 4 speed actual value is received via analog input 2.
- ◆ P210.x = Enter the maximum occurring speed (in RPM) (it is absolutely necessary that the speed overshoot is taken into account - typical value: 10 %!). An input signal of 10 V at the analog input corresponds to the speed set here.
- ◆ P163.x = 1 control with V/Hz characteristic or 3 closed-loop frequency control
- ◆ P052 = 0 Return from the „drive setting“ function
- ◆ With the motor stationary, select r214 (n(act, encoder)), and if required, adjust the zero point using P652.1(2).
- ◆ If possible, de-couple the motor from the load.
- ◆ Power-up the unit and operate the drive at various speeds. Measure the speed, for example, using a hand-held tachometer, and adjust the potentiometer on the ATI board so that the measured value coincides with the display in r214.
- ◆ If the motor is operated under no load (no-load operation), it is adjusted, if the setpoint and actual value speeds are the same (r482 = r214).
- ◆ P651.1(2) smoothing time constant ineffective, use P221 for smoothing.
- ◆ P052 = 5 „Drive setting“ function
- ◆ P163.x = 0 V/Hz+speed control or 4 speed control
- ◆ P052 = 0 Return from „drive setting“
- ◆ When required, the speed actual value can be smoothed via P221, and a maximum value for the permissible speed change entered using P215 (see the function diagrams in Chapter 10).

Special case: The tachometer voltage at the maximum occurring speed is < 10 V.

- ◆ Connect the tachometer voltage directly at the analog input.
- ◆ Set P210.x to that speed, where the tachometer voltage is 10 V (the value can exceed the maximum occurring speed).

Example for using the analog input as speed actual value input:

The speed actual value is to be fed in via analog input 2.

Tachometer and system data: Analog tachometer with 30 V / 1000 RPM
Speed at the maximum setpoint: 1700 RPM

Parameterization:

- ◆ Ground the tachometer cable shield at 1 end, at the drive converter.
If noise is coupled-in, connect a 100 nF capacitor to the motor housing.
- ◆ P052 = 5 „Drive setting“ function
- ◆ P053 = 3 „Expert mode“ access stage
- ◆ P208.1 = 4 Connect the speed actual value to analog input 2.
- ◆ P210.x = Enter the maximum occurring speed (in RPM):
1700 RPM + e.g. 8 % for overshoot → 1836 RPM.
- ◆ Tachometer voltage at the maximum speed: 55 V -> the ATI board is required.
- ◆ P163.1 = 1 Control with V/Hz characteristic
or 3 frequency control
- ◆ P052 = 0 return from the „drive setting“
- ◆ With the motor stationary, select r214, and if required, adjust the zero point using P652.2.
- ◆ Power-up the unit and operate the drive at various speeds (e.g. 500, 1000 and 1500 RPM). Measure the speed, for example, using a handheld tachometer, and adjust the potentiometer on the ATI board so that the measured value coincides with the display in r214 (the display is realized in Hz).
- ◆ Specify additional steps as above.

6.4 Analog outputs

The CU control board has 2 analog outputs (AO) to output actual values and other internal quantities of the drive converter (Connection  Chapter 1).

Technical data:

- ◆ Output voltage range -10 V to +10 V
- ◆ 5 mV resolution (11 bits + sign)
- ◆ Accuracy ± 1 %
- ◆ Output current, max. ± 5 mA
- ◆ Short-circuit proof
- ◆ Not floating

Additional details,  Function diagram „Analog output“, Chapter 10.

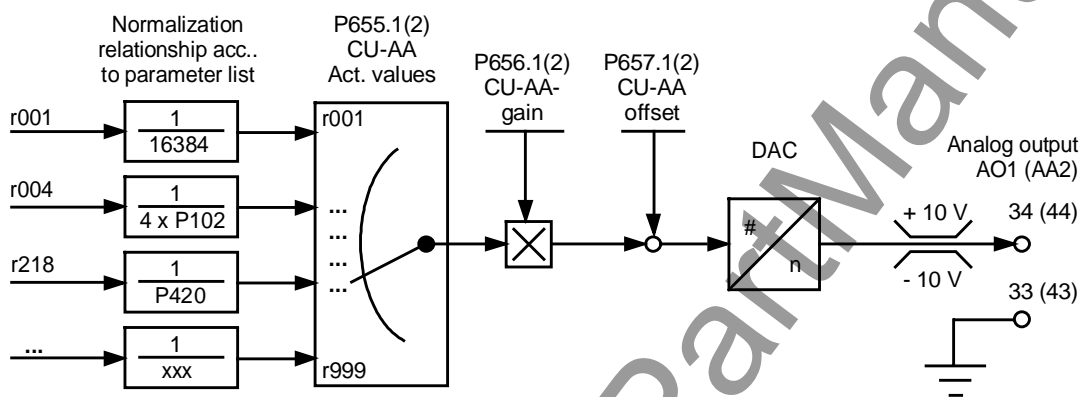

Fig. 6.5 Analog output

Normalization:

The values of the parameters to be output are weighted with the normalization relationships specified in the parameter list (e.g. r004 (output current) referred to 4 x p102 (rated motor current)).

Example:

P656 = 10 V
 Analog output = 10 V, if r004 = 4 x P102

P656 = 40 V
 Analog output = 10 V, if r004 = P102

Parameterization:

- ◆ The number of the parameter, whose value is to be output at the analog output, is entered in P655 (CU-AA actual values).

In this case, index P655.1 corresponds to analog output 1, P655.2 to analog output 2.

- ◆ Corresponding to points X_2, Y_2 and X_1, Y_1 , the required analog output characteristics are defined, set gain P656 and offset P657:

$$P656.x = \frac{Y_2 - Y_1}{(X_2 - X_1) / \text{ref. quantity}}$$

$$P657.x = \frac{(Y_1 X_2) - (Y_2 X_1)}{X_2 - X_1}$$

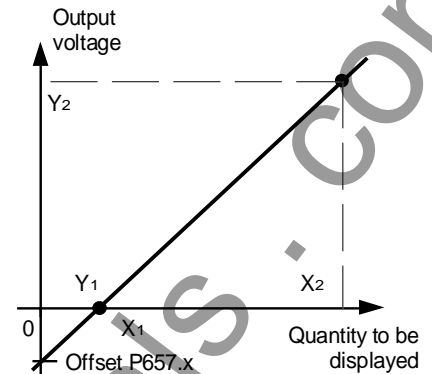

Fig. 6.6 Analog output

Examples:

1. The output current (r004) is to be represented as 0 V to +10 V at analog output 2 in the range 32 A to 160 A.

The rated motor current (P102) is 40.0 A.

Parameterization:

- ◆ P655.2 = 004 The output current is connected to analog output 2.
- ◆ The reference quantity for r004 is taken from the parameter list. It is $4 \times P102$.
- ◆ Set the gain and offset (index '2' for analog output 2):

$$P656.2 = \frac{10 \text{ V} - 0 \text{ V}}{(160 \text{ A} - 32 \text{ A}) / (4 \times 40 \text{ A})} = 12.5 \text{ V}$$

$$P657.2 = \frac{(0 \text{ V} \times 160 \text{ A}) - (10 \text{ V} \times 32 \text{ A})}{160 \text{ A} - 32 \text{ A}} = -2.50 \text{ V}$$

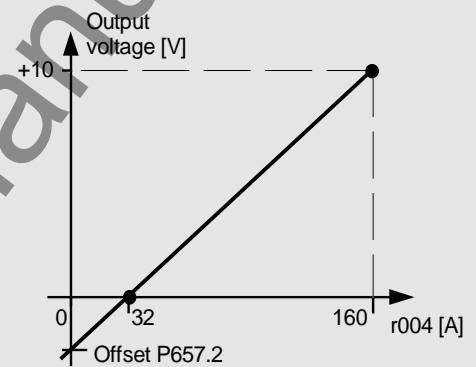

Fig. 6.7 Example, output current at the analog output

2. The frequency actual value (r218) is to be represented as -10 V to +10 V at analog output 1 from -2 Hz to +5 Hz.

The rated system frequency (P420) is 100 Hz.

Parameterization:

- ◆ P655.1 = 218 The frequency actual value is connected to analog output 1.
- ◆ Take the reference quantity for r218 from the parameter list. It is P420.
- ◆ Set the gain and offset (index '1' for analog output 1):

$$P656.1 = \frac{10 \text{ V} + 10 \text{ V}}{(5 \text{ Hz} + 2 \text{ Hz}) / 100 \text{ Hz}} = 285.71 \text{ V}$$

$$P657.1 = \frac{(-10 \text{ V} \times 5 \text{ Hz}) - (10 \text{ V} \times (-2 \text{ Hz}))}{5 \text{ Hz} + 2 \text{ Hz}} = -4.29 \text{ V}$$

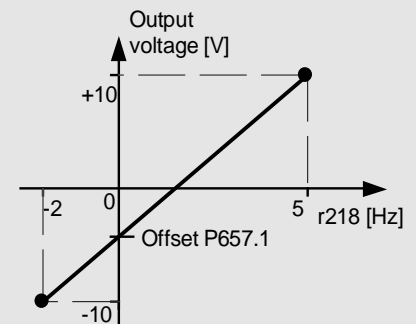

Fig. 6.8 Example, frequency actual value at the analog output

6.5 Serial interfaces

6.5.1 Basic converter interfaces SST1 and SST2

The USS protocol (universal serial interface) is implemented at the basic converter interfaces SST1 and SST2.

The following documentation is available depending on the particular application of the SST1 basic converter interface:

- ◆ Connecting a PC / PG with SIMOVIS software for start-up / service operator control:
The documentation is provided on SIMOVIS floppy disks in files BEDANLTG.TXT (ASCII format) and BEDANLTG.WRI (WRITE format).
- ◆ Connecting higher-level PLCs with the USS protocol:
SIMOVERT MASTER DRIVES
Using the serial interfaces with USS protocol
Order No.: 6SE7087-6CX87-4KB0

Additional general comments regarding connecting-up and parameterization:

- ◆ **Connecting-up:** Chapter 1 „Control terminal strip“

SST1: 9-pin SUB D connector -X300 on the PMU parameterizing unit (RS 232 or RS 485)

SST2: Connector -X100 on the CU control terminal strip (RS 485)

When connecting SST2 via the terminal strip (-X100), of the CU, a four-wire connection can be implemented. The changeover between two- and four-wire connection is realized automatically.

NOTE
<p>The bus terminating resistors (total 150 Ω) must be switched-in at the last bus node (slave). Fig. 6.9 for the position of the jumpers S1 and S3.</p> <ul style="list-style-type: none"> • SST1: Close jumpers S1.1 and S1.2 of DIP-FIX S1 on the CU. • SST2: Close jumpers S2.1 and S2.2 of DIP-FIX S2 on the CU.

Parameterization:

- Define the process data: **P683 bis P687**
- Connect process data (control word, status word, setpoints, actual values) to the interfaces
 Chapter 5 „Process data“
- Enabling parameterization: **P053 oder P927**

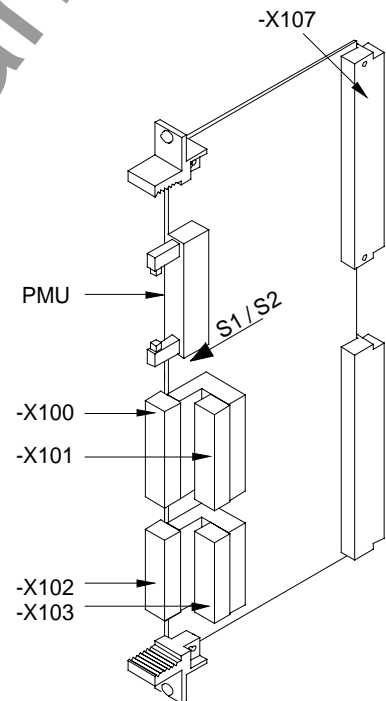

Fig. 6.9 CU

6.5.2 Dual port RAM (DPR for SCB, TSY, CB, TB)

The dual port RAM is the internal interface on the CU (-X107) to connect possible option boards via the LBA (Local Bus Adapter, option) of the electronics box.

Possible option boards:

- TSY (tachometer- and synchronization board),
- TB (Technology board),
- SCB (serial communications board),
- CB (Communications board).

To connect possible option boards and parameterize the interface, see Chapter „Options“ in the Operating Instructions, Part 1 as well as the Operating Instructions of the option boards.

Additional information, see Chapter 5 „Process data“.

6.6 Ramp-function generator (RFG) and limiting stage in front of the ramp-function generator

A detailed description as supplement to the „Function diagrams, setpoint channel CU“, Chapter 10

6.6.1 Ramp-function generator, RFG

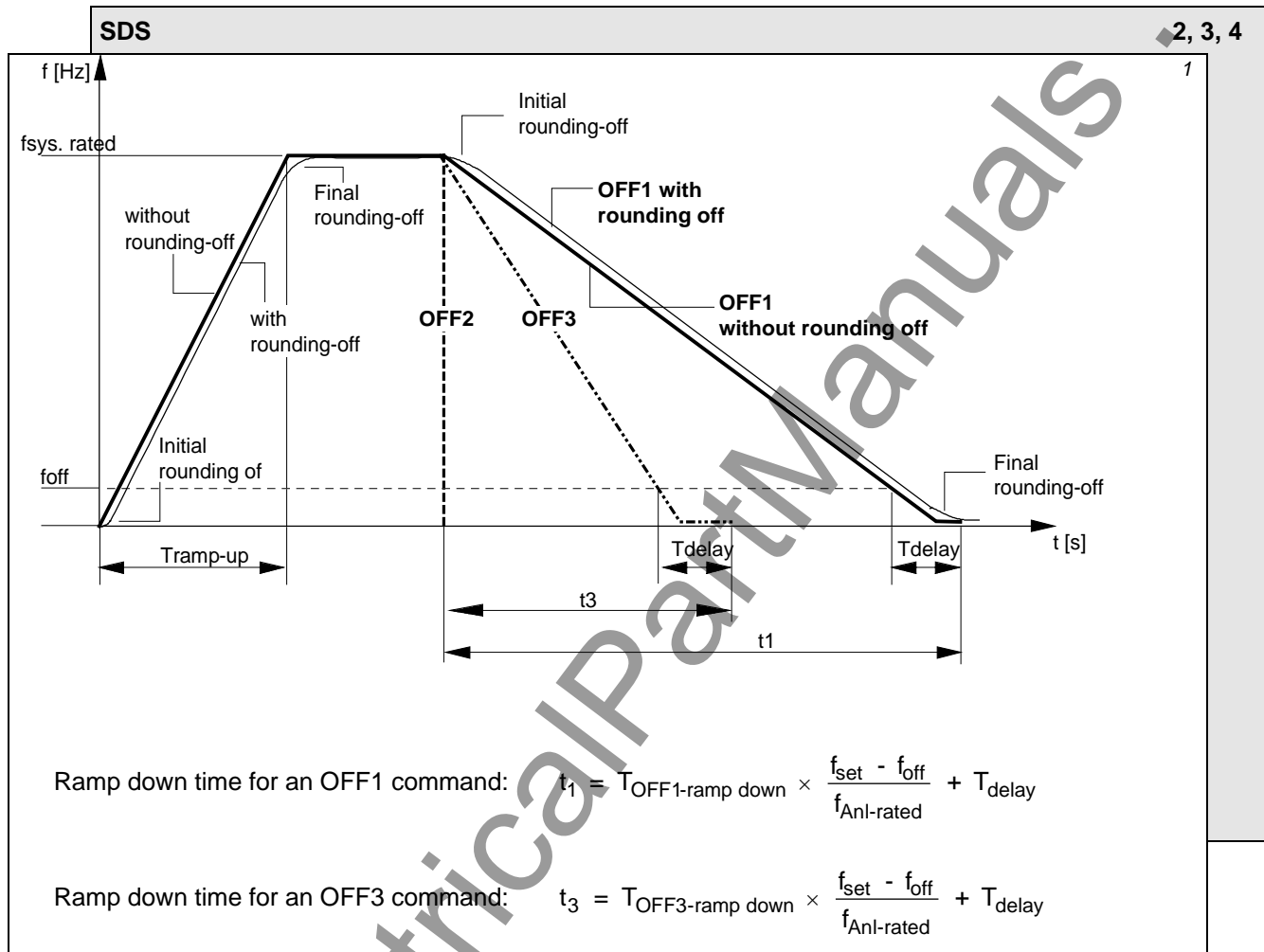

Fig. 6.10 Ramp-function generator

For a detailed description of the OFF1-, OFF2- and OFF3 commands, refer to Section 5.1.2 „Control word 1“

Parameters for setting the acceleration time

P420	Rated system frequency ($f_{\text{rated system}}$)		1.00 Hz to 600.00 Hz
P462	Acceleration time ($T_{\text{acceleration}}$)	i001: SDS1 to i004: SDS4	0.0 to 999.9 (Units: P463)
Acceleration time from standstill up to rated system frequency, (P420)			
P463	Units, acceleration time	i001: SDS1 to i004: SDS4	0: seconds 1: minutes 2: hours
Time units for the acceleration time (P462)			

P464	Deceleration time (T _{decelerate})	i001: SDS1 to i004: SDS4	0.0 to 999.9 (Units: \rightarrow P465)
Deceleration time from the rated system frequency (P420) down to standstill			

P465	Units, deceleration time	i001: SDS1 to i004: SDS4	0: seconds 1: minutes 2: hours
Time units for the acceleration time (P464)			

P466	OFF3 deceleration time (T _{OFF3 deceleration})		0.0 s to 999.9 s
Deceleration time for an OFF3 command (if DC braking, P372 is not selected) in s from the rated system frequency (P420) down to standstill. Rounding-off (P469 and P470) is de-activated.			

P467	Protective ramp-up K _p	i001: SDS1 to i004: SDS4	1.0 to 100.0
<p>◆ Closed-loop V/f control (P163 = 0, 1, 2) Factor from 1.0 to 100.0 referred to the acceleration time, P462, to enter a protective ramp-up time. This is only effective, if seconds are selected as the ramp-up time units: P463 = 0 Using the protective ramp-up, the acceleration time up to 15% of the rated motor frequency (P107) can be extended (\rightarrow Fig. 6.11 „Protective ramp-up“) Protective ramp-up is not activated for 1.0. The total acceleration time can be calculated according to: $\text{total run-up} = P462 + P462 \times \frac{15}{100} \times \frac{P107}{P420} \times (P467 - 1)$</p> <p>◆ Closed-loop frequency control (P163 = 3) The protective ramp-function generator is effective up to 110% of the changeover frequency to the EMF model (P284). Ramp-up is also influenced by the current input (P202, P203 and P204) if the EMF model is inactive (P284 = 0).</p> <p>◆ Closed-loop speed/torque control (P163 = 4, 5) The protective ramp-function generator is ineffective</p>			

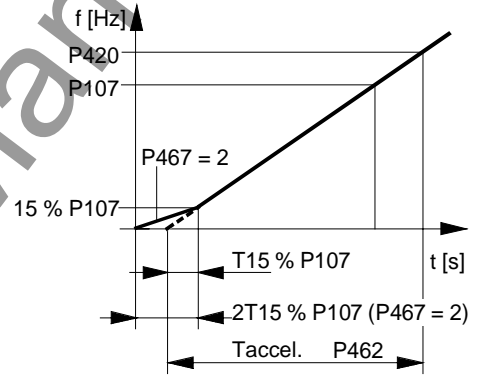

Fig. 6.11 Protective ramp-up

P469	Initial rounding-off	i001: SDS1 to i004: SDS4	0 % to 50 %
-------------	----------------------	-----------------------------	-------------

Initial rounding-off in % referred to the acceleration time, P462, when accelerating or the deceleration time, P464, when decelerating.
When accelerating, this is only effective, if seconds are selected for the acceleration time units: P463 = 0
When decelerating, this is only effective, if seconds are selected for the deceleration time units: P465 = 0

◆ Example: Acceleration time P462 = 10 s, rounding-off = 10 %.
Thus, the acceleration time is extended by 1 s.

When accelerating from standstill up to the rated system frequency (P420), the effective acceleration time is increased to: $P462 \times (1 + P469/100 \% + P470/100 \%)$
The same is valid for the deceleration time.

◆ If the motorized potentiometer is active (control word bits 13 and 14 set; \rightarrow Section 5.1), there is no rounding-off

P470	Final rounding-off	i001: SDS1 to i004: SDS4	0 % to 50 %
<p>Final rounding-off in % referred to the acceleration time, P462, when accelerating, or the deceleration time, P464, when decelerating.</p> <p>When accelerating, this is only effective, if seconds are selected for the acceleration time units: P463 = 0</p> <p>When decelerating, this is only effective, if seconds are selected for the deceleration time units: P465 = 0</p> <ul style="list-style-type: none"> ◆ Example: Acceleration time P462 = 10 s, rounding-off = 10 %. <p>Thus, the acceleration time is extended by 1 s.</p> <p>When accelerating from standstill up to the rated system frequency (P420), the effective acceleration time is increased to: $P462 \times (1 + P469/100 \% + P470/100 \%)$</p> <p>The same is valid for the deceleration time.</p> <ul style="list-style-type: none"> ◆ If the motorized potentiometer is active (control word bits 13 and 14 set; see Section 5.1), there is no rounding-off 			

P475	RFG tracking		0.0 % to 50.0 %
<p>Only effective, if P163 (open-/closed-loop control type) = 4 (closed-loop speed control)</p> <p>For setpoint changes, and when the torque limits are reached (r235 „Mmax n/f control or r236 „Mmin n/f control“), the actual control error is sensed at the speed controller input (r224) (known here as: r224(limit)).</p> <p>If this value falls below $r224 = r224(\text{limit}) + P475 \times r224(\text{limit})$, the ramp-function generator tracking is activated.</p> <p>This means: The ramp-function generator output frequency is increased so fast, that the drive operates at the torque limit (the control error at the speed controller input (r224) is kept constant).</p> <p>Thus, it is ensured that the ramp-function generator output frequency does not drift when the torque limits are reached, so that it can respond faster when the converter is powered-down or when setpoint changes are made.</p> <p>Final rounding-off (P470) is <u>not</u> realized if the ramp-function generator tracking is activated.</p> <p>The ramp-function generator tracking is not activated for 0.0%.</p>			

P514	OFF shutdown frequency (f_{off})		0.00 Hz to 600.0 Hz
<p>As soon as the „speed/frequency actual value“ r218 reaches the OFF shutdown frequency, P14 when the drive decelerates (OFF1 or OFF3 without DC braking, P372), then the OFF delay time P516, starts to run. After this, the inverter pulses are inhibited.</p>			

P516	OFF delay time (T_{delay})	i001: SDS1 to i004: SDS4	0.0 s to 60.0 s
<p>Delay time for OFF1 and OFF3 (if no DC braking, P372 is selected for OFF3) in s.</p> <p>As soon as the „speed/frequency actual value“ (r218) reaches the OFF shutdown frequency (P514) when the drive decelerates, the OFF delay time starts to run. The inverter pulses are then inhibited.</p>			

Further, it is still possible to inhibit or hold the ramp-function generator via the „Control word“ (Section 5.1).

6.6.2 Limit value stage in front of the ramp-function generator

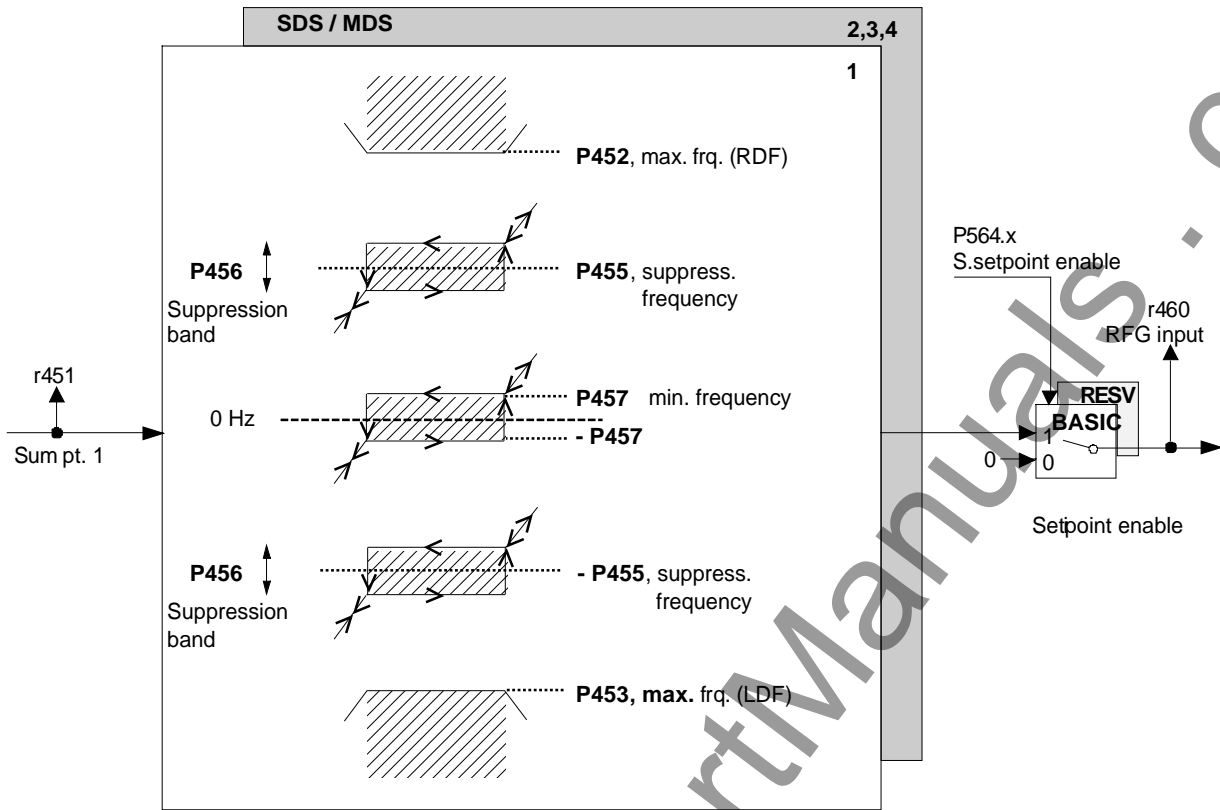

Fig. 6.12 Limit value stage before the ramp-function generator

P452	Max. frequency (RDF)	i001: MDS1	0.0 Hz to 600.0 Hz
	Clockwise phase sequence	to i004: MDS4	
Max. setpoint frequency for a clockwise phase sequence			

P453	Max. frequency (LDF)	i001: MDS1	-600.0 Hz to 0.0 Hz
	Counter-clockwise phase sequence	to i004: MDS4	
Max. setpoint frequency for a counter-clockwise phase sequence			

P455	Suppression frequency	i001: SDS1	0.0 Hz to 600.0 Hz
		to i004: SDS4	
Frequency suppression of $\pm \frac{1}{2} \times P456$ (suppression bandwidth) on each side of the parameterized suppression frequency (is valid for positive and negative setpoints), in order to prevent steady-state drive operation at possible resonant frequencies.			
<ul style="list-style-type: none"> Steady-state operation in a parameterized suppression bandwidth (P456) is therefore not possible; the range can only be run-through. For a setpoint at summation point 1 in front of the ramp-function generator, r451, which lies within the suppression bandwidth, the setpoint, increasing from below is held at the lower limit, and the setpoint decreasing from above is held at the upper limit. The suppression bandwidth is <u>not</u> activated when a suppression frequency of 0.0 Hz is entered. 			

P456	Suppression bandwidth	i001: SDS1	0.0 Hz to 600.0 Hz
		to i004: SDS4	
Width of the suppression bandwidth when frequency suppression is parameterized ($\frac{1}{2} \times P455$)			

P457	Min. frequency	i001: SDS1 to i004: SDS4	-600.0 Hz to 600.0 Hz ≤ max. frequency LDF/RDF
<p>It is possible to realize a 0 Hz frequency suppression using the minimum frequency.</p> <ul style="list-style-type: none"> ◆ Steady-state operation in the range 0 Hz ± minimum frequency is therefore not possible; the range can only be run-through. ◆ After the drive has been switched-on, and for a setpoint at summation point 1 in front of the ramp-function generator, r451, in the range from 0 Hz up to the positive minimum frequency, the positive minimum frequency is approached, and in the range 0 Hz up to the negative minimum frequency, the negative minimum frequency. ◆ In operation, and for a setpoint at summation point 1 in front of the ramp-function generator, r451, in the suppression bandwidth (0 Hz ± minimum frequency), the setpoint increasing from below is held at the lower limit, and the setpoint decreasing from above, is held at the upper limit. ◆ The drive can be reversed by entering a reference frequency at summation point 1, which is outside the frequency suppression range. <p>A negative minimum frequency is only effective for closed-loop torque control and a selected slave drive (see Chapter 10 „Function diagrams“)</p>			

www.ElectricalPartManuals.com

7 Open-loop and closed-loop control types

7.1 V/f characteristic

A detailed description as supplement to the „Function diagrams, V/f characteristic“, Chapter 10.

Prerequisite: P163 (Open-/closed-loop control type) = 0, 1 or 2 (V/f characteristics)

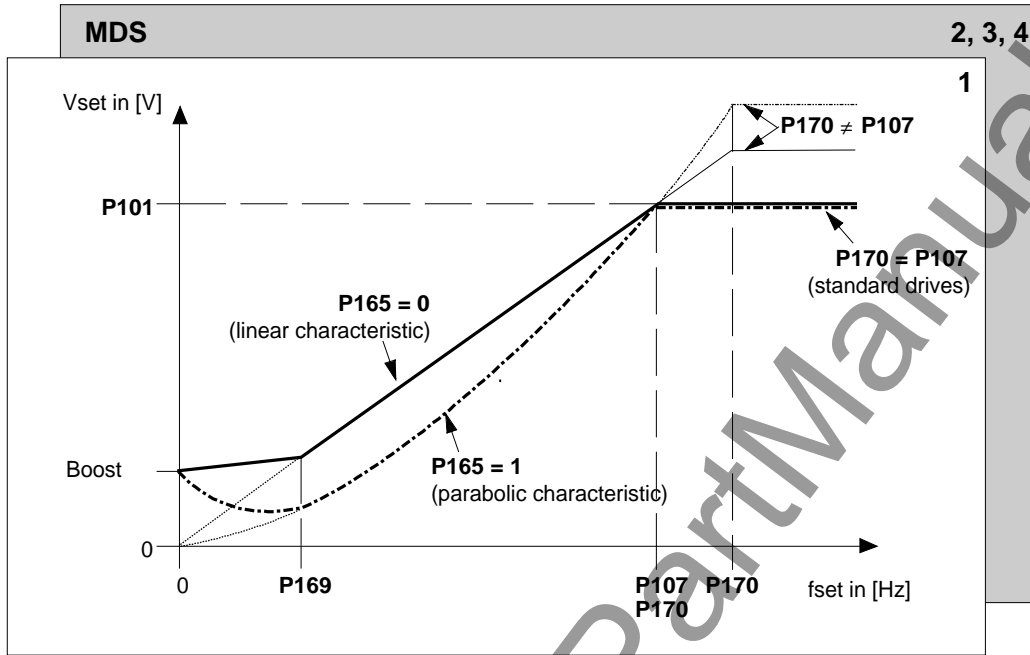







Fig. 7.1 V/f characteristic

- Boost:
- ◆ P166 = 0: current reference: P167 (taking into account P272)
 - ◆ P166 = 1: voltage reference: P168
 - ◆ P171: Acceleration current

P101	Motor voltage (n)	i001: MDS1 to i004: MDS4	115.0 V to 1600.0 V
Rating plate value of the rated motor voltage (observe whether the motor is connected in star or delta!) For SIMOSYN motors: Voltage at the rated drive frequency			
P107	Motor frequency (n)	i001: MDS1 to i004: MDS4	8.0 Hz to 600.0 Hz
Rating plate value of the rated motor frequency			
P165	Characteristic	i001: MDS1 to i004: MDS4	0 and 1
V/f characteristic type: 0: Linear characteristic (constant-torque drives) 1: Parabolic characteristic (fans and pumps)			

P166	Boost	i001: MDS1 to i004: MDS4	0 and 1
<p>Select the boost reference type (for high-inertia starting and compensating the ohmic voltage drops across the motor feeder/stator winding of the drives at low frequencies):</p> <p>0: Current reference via P167 Voltage for $f = 0$ Hz for the starting current (conversion using P272 (R (stator + feeder cable)))</p> <p>1: Voltage reference via P168 Voltage for $f = 0$ Hz</p>			
P167	Boost current	i001: MDS1 to i004: MDS4	10.0 % to 400.0 %
<p>Only valid for current reference: (P166 = 0)</p> <p>Boost current for $f=0$ Hz as a % referred to the rated motor current (P102)</p> <ul style="list-style-type: none"> ◆ The boost current is reduced to 0 when the boost end frequency (P169) is reached. ◆ The boost current is converted into a voltage boost taking into account (P272 (R (stator + feeder cable))). 			
NOTE			
P272 (R(stator + feeder cable)) should be calculated or measured using „Automatic parameterization“ or even better, using „motor identification“ (function selection P052,  Section 8.1)!			
P168	Boost voltage	i001: MDS1 to i004: MDS4	10.00 % to 25.00 %
<p>Only valid for voltage reference: (P166 = 1)</p> <p>Boost voltage at $f = 0$ Hz as a % referred to the rated motor voltage (P101)</p> <ul style="list-style-type: none"> ◆ The boost voltage is reduced to 0 when the „boost end frequency“ (P169) is reached. ◆ P168 is calculated during „automatic parameterization“ or „motor identification“ (function selection P052,  Section 8.1). 			
P169	Boost end frequency	i001: MDS1 to i004: MDS4	0.0 Hz to 300.0 Hz
<p>In the range from 0 Hz up to the boost end frequency, the voltage boost value (P167 or P168) is reduced to 0</p> <ul style="list-style-type: none"> ◆ Special case: For P169 = 0.0 Hz and specified voltage boost (P167 \neq 0 % or P168 \neq 0 %), the voltage from 0 Hz up to the intersection point of the non-boosted V/f characteristic is kept constant to the value corresponding to the reference entered using P167 or P168 (horizontal boost). ◆ P169 is set to 20% of the rated motor frequency (P107) using the „automatic parameterization“ (function selection P052,  Section 8.1). 			
P170	Field weakening frequency	i001: MDS1 to i004: MDS4	8.0 Hz to 600.0 Hz
<p>Frequency at the start of field weakening</p> <ul style="list-style-type: none"> ◆ The voltage is kept constant above this frequency limit. When the conveter voltage limit (r181) is reached before this frequency, field weakening is started appropriately earlier. The actual field-weakening frequency can be read from parameter r182 (fieldweakfrq(act)). ◆ P170 is set to the rated motor frequency (P107) standard drives during „automatic parameterization“ (function selection P052,  Section 8.1). 			

P171	Acceleration current	i001: MDS1 to i004: MDS4	0.0 % to 799.9 %
Acceleration current (supplementary boost current) for active acceleration for high-inertia starting as a [%] referred to the rated motor current (P102) <ul style="list-style-type: none"> ◆ The acceleration current is only switched-in up to the „boost end frequency“ (P169). ◆ The acceleration current is converted into a voltage boost taking into account P272 (R(stator total)). 			
NOTE			
P272 „R(stator, total)“ should be calculated or measured using „automatic parameterization“ or even better using „motor identification“ (function selection P052,  Section 8.1!			

Further, it is possible,

- ◆ to set load-dependent voltage injection to compensate for voltage drops across the motor feed cables using P172 „IxR compensation Kp“.
- ◆ to set soft starting P190 (to ramp-up the characteristic voltage when powering-up within the excitation time P189).

7.2 Vector control types

 Function diagrams (Chapter 10) for closed-loop frequency/speed/torque control (P163 = 3, 4, 5).

www.ElectricalPartManuals.com

8 Start-up functions

8.1 Function selection (P052)

Function selection is activated via parameter **P052** and permits various special functions during the start-up phase.

Condition: Access stage 2 (**P051 = 2**) must be enabled and the converter may only be in the „Run“ (R) status.

The following functions are available:

- ◆ Return from function selection (P052 = 0)
- ◆ Factory setting (P052 = 1)
- ◆ Initialization (P052 = 2)
- ◆ Download (P052 = 3)
- ◆ Hardware configuration (P052 = 4)
- ◆ Drive setting (P052 = 5)
- ◆ Automatic parameterization (P052 = 6)
- ◆ Motor identification at standstill (P052 = 7)
- ◆ Automatic parameterization (P052 = 6)
- ◆ Motor identification at standstill (P052 = 7)
- ◆ Complete motor identification (P052 = 8)
- ◆ No-load measurement (P052 = 9)
- ◆ n/f controller optimization (P052 = 10)
- ◆ Self-test (P052 = 11)
- ◆ Tachometer test (P052 = 12)

The „initialize“, „download“, „hardware configuration“, and „drive setting“ functions must be manually reset after completion, i.e. P052 = 0 („return“)!

The remaining functions are automatically reset after completion

P052 = 5 can be exited using P052 = 0, 6, 7, 8, 11.

P052 = 6 can only be selected from the "drive setting" (P052 = 5).

8.1.1 Factory setting (P052 = 1)

Function: This function is used to establish the factory setting (the same as when the unit was shipped) for all of the parameters (see Chapter 11 „Parameter list“). Observe the pre-setting of P077!

Condition: The „factory setting“ can be realized in the status DRIVE SETTING (005), FAULT (007), SWITCH-ON INHIBIT (008) or READY TO SWITCH-ON (009).

Result: In this case, several drive converter- and motor data as well as several open-loop/closed-loop control parameters („automatic parameterization“) are set according to the drive converter type (MLFB dependent / P070).

Procedure:

- ↓ P052 = 1 Function selection „Factory setting“
- ↓ P key The numbers of the newly-assigned parameters are consecutively displayed:
 - ◆ Factory setting of **all** parameters according to the parameter list (Chapter 11) (also the board configuration P090/P091)
 - ◆ Drive converter data (determined from the MLFB of the drive converter (P070))
 - P071 Drive converter supply voltage
 - P072 Drive converter current (n)
 - P073 Drive converter output (n)
 - ◆ Motor data (determined from the MLFB of the drive converter (P070))
 - P101 Motor voltage (n)
 - P102 Motor current (n)
 - P104 Motor cos phi (n)
 - P105 Motor output (n)
 - P106 Motor efficiency (n)
 - P109 Motor pole pair number
 - P173 I_{max} (max. current)
 - ◆ Open-loop/closed-loop control parameter
„Automatic parameterization“ is executed (→ Section 8.1.5). **All** motor data sets are re-assigned.
- ↓ After the factory setting has been completed, SWITCH-ON INHIBIT (008) or READY TO SWITCH-ON (009) are displayed

8.1.2 Initialization (MLFB input) (P052 = 2)

Function: This function is used to change the model No. (unit type).

Condition: „Initialization“ can be realized in the DRIVE SETTING (005), FAULT (007), SWITCH-ON INHIBIT (008) or READY TO SWITCH-ON (009).

Result: When the Model No. **is changed** the factory setting is only **partially** established (as when the unit is shipped), depending on the new model No. The process data connection retained.

Procedure:

- ↓ P051 = 3 access stage „Expert mode“ (in order to change P070)
- ↓ P052 = 2 function selection „Initialization“
- ↓ P070 = MLFB (specifies the MLFB (machine-readable product designation = model No.) of the drive converter (→ type plate).
When changing the CU, the MLFB corresponding to the drive converter must be input.
When parameterizing via the PMU, the appropriate identification number (PWE) must be specified in accordance with the following table:

Table of SIMOVERT MASTER-DRIVES

minimum pulse frequency = 1.5 kHz
rated pulse frequency = 2.5 kHz

Brief description of the table columns:

PWE parameter value (enter for initialization / PMU / P070)

I(n) rated drive converter current in A (P072)

V cl. voltage class, voltage range

PWE	Model No.	I(n)	U-KI.
1	6SE7014-5FB20	4,5	3AC 500-575
2	6SE7014-5UB20	4,5	DC 675-780
3	6SE7016-1EA20	6,1	3AC 380-460
4	6SE7016-1TA20	6,1	DC 510-620
5	6SE7016-2FB20	6,2	3AC 500-575
6	6SE7016-2UB20	6,2	DC 675-780
7	6SE7017-8FB20	7,8	3AC 500-575
8	6SE7017-8UB20	7,8	DC 675-780
9	6SE7018-0EA20	8,0	3AC 380-460
10	6SE7018-0TA20	8,0	DC 510-620
11	6SE7021-0EA20	10,2	3AC 380-460
12	6SE7021-0TA20	10,2	DC 510-620
14	6SE7021-1CA20	10,6	3AC 208-230
15	6SE7021-1RA20	10,6	DC 280-310
16	6SE7021-1FB20	11,0	3AC 500-575
17	6SE7021-1UB20	11,0	DC 675-780
18	6SE7021-3EB20	13,2	3AC 380-460
19	6SE7021-3TB20	13,2	DC 510-620
21	6SE7021-3CA20	13,3	3AC 208-230
22	6SE7021-3RA20	13,3	DC 280-310
23	6SE7021-5FB20	15,1	3AC 500-575
24	6SE7021-5UB20	15,1	DC 675-780
25	6SE7021-8EB20	17,5	3AC 380-460
26	6SE7021-8TB20	17,5	DC 510-620
27	6SE7021-8CB20	17,7	3AC 208-230
28	6SE7021-8RB20	17,7	DC 280-310
30	6SE7022-2FC20	22,0	3AC 500-575
31	6SE7022-2UC20	22,0	DC 675-780
32	6SE7022-3CB20	22,9	3AC 208-230
33	6SE7022-3RB20	22,9	DC 280-310
35	6SE7022-6EC20	25,5	3AC 380-460
36	6SE7022-6TC20	25,5	DC 510-620
37	6SE7023-0FD20	29,0	3AC 500-575
38	6SE7023-0UD20	29,0	DC 675-780
39	6SE7023-2CB20	32,2	3AC 208-230
40	6SE7023-2RB20	32,2	DC 280-310
42	6SE7023-4EC20	34,0	3AC 380-460
43	6SE7023-4TC20	34,0	DC 510-620
44	6SE7023-4FD20	34,0	3AC 500-575
45	6SE7023-4UD20	34,0	DC 675-780
46	6SE7023-8ED20	37,5	3AC 380-460
47	6SE7023-8TD20	37,5	DC 510-620
48	6SE7024-4CC20	44,2	3AC 208-230
49	6SE7024-4RC20	44,2	DC 280-310
50	6SE7024-7FD20	46,5	3AC 500-575
51	6SE7024-7UD20	46,5	DC 675-780

PWE	Model No.	I(n)	U-KI.
52	6SE7024-7ED20	47,0	3AC 380-460
53	6SE7024-7TD20	47,0	DC 510-620
54	6SE7025-4CD20	54,0	3AC 208-230
55	6SE7025-4RD20	54,0	DC 280-310
56	6SE7026-0ED20	59,0	3AC 380-460
57	6SE7026-0TD20	59,0	DC 510-620
58	6SE7026-0HF20	60	3AC 660-690
59	6SE7026-0WF20	60	DC 890-930
60	6SE7026-1FE20	61	3AC 500-575
61	6SE7026-1UE20	61	DC 675-780
62	6SE7026-6FF20	66	3AC 500-575
63	6SE7026-6UF20	66	DC 675-780
64	6SE7027-0CD20	69,0	3AC 208-230
65	6SE7027-0RD20	69,0	DC 280-310
66	6SE7027-2ED20	72,0	3AC 380-460
67	6SE7027-2TD20	72,0	DC 510-620
68	6SE7028-0FF20	79,0	3AC 500-575
69	6SE7028-0UF20	79,0	DC 675-780
70	6SE7028-1CD20	81,0	3AC 208-230
71	6SE7028-1RD20	81,0	DC 280-310
72	6SE7028-2HF20	82,0	3AC 660-690
73	6SE7028-2WF20	82,0	DC 890-930
74	6SE7031-0EE20	92,0	3AC 380-460
75	6SE7031-0TE20	92,0	DC 510-620
76	6SE7031-0HG20	97,0	3AC 660-690
77	6SE7031-0WG20	97,0	DC 890-930
78	6SE7031-1FG20	108,0	3AC 500-575
79	6SE7031-1UG20	108,0	DC 675-780
80	6SE7031-2HG20	118,0	3AC 660-690
81	6SE7031-2WG20	118,0	DC 890-930
82	6SE7031-2EF20	124,0	3AC 380-460
83	6SE7031-2TF20	124,0	DC 510-620
84	6SE7031-3FG20	128,0	3AC 500-575
85	6SE7031-3UG20	128,0	DC 675-780
88	6SE7031-5HG20	145,0	3AC 660-690
89	6SE7031-5WG20	145,0	DC 890-930
90	6SE7031-5EF20	146,0	3AC 380-460
91	6SE7031-5TF20	146,0	DC 510-620
94	6SE7031-6FG20	156,0	3AC 500-575
95	6SE7031-6UG20	156,0	DC 675-780
96	6SE7031-7HG20	171,0	3AC 660-690
97	6SE7031-7WG20	171,0	DC 890-930
98	6SE7031-8EF20	186,0	3AC 380-460
99	6SE7031-8TF20	186,0	DC 510-620
100	6SE7032-0FH20	192,0	3AC 500-575
101	6SE7032-0UH20	192,0	DC 675-780

PWE	Model No.	I(n)	U-KI.
102	6SE7032-1EG20	210,0	3AC 380-460
103	6SE7032-1TG20	210,0	DC 510-620
104	6SE7032-3FH20	225,0	3AC 500-575
105	6SE7032-3UH20	225,0	DC 675-780
106	6SE7032-1HH20	208,0	3AC 660-690
107	6SE7032-1WH20	208,0	DC 890-930
108	6SE7032-6EG20	260,0	3AC 380-460
109	6SE7032-6TG20	260,0	DC 510-620
112	6SE7033-2EG20	315,0	3AC 380-460
113	6SE7033-2TG20	315,0	DC 510-620
116	6SE7033-7EH20	370,0	3AC 380-460
117	6SE7033-7TH20	370,0	DC 510-620
118	6SE7034-5UK20	452,0	DC 675-780
119	6SE7034-5WK20	452,0	DC 890-930
120	6SE7035-1TJ20	510,0	DC 510-620
121	6SE7035-7UK20	570,0	DC 675-780
122	6SE7035-7WK20	570,0	DC 890-930
123	6SE7036-0TK20	590,0	DC 510-620
124	6SE7036-5UK20	650,0	DC 675-780
125	6SE7036-5WK20	650,0	DC 890-930
126	6SE7037-0TK20	690,0	DC 510-620
127	6SE7038-6TK20	860,0	DC 510-620
128	6SE7038-6UK20	860,0	DC 675-780
129	6SE7038-6WK20	860,0	DC 890-930
130	6SE7041-0UM20	990,0	DC 675-780
131	6SE7041-0WM20	990,0	DC 890-930
132	6SE7041-1UM20	1080,0	DC 675-780
133	6SE7041-1WM20	1080,0	DC 890-930
134	6SE7041-1TM20	1100,0	DC 510-620
135	6SE7041-1TK20	1100,0	DC 510-620
138	6SE7041-2UM20	1230,0	DC 675-780
139	6SE7041-2WM20	1230,0	DC 890-930
140	6SE7041-3TM20	1300,0	DC 510-620
144	6SE7041-4UM20	1400,0	DC 675-780

PWE	Model No.	I(n)	U-KI.
145	6SE7041-4WM20	1400,0	DC 890-930
148	6SE7041-6UM20	1580,0	DC 675-780
149	6SE7041-6WM20	1580,0	DC 890-930
155	6SE7041-8UR20	1850,0	DC 675-780
156	6SE7041-8WR20	1850,0	DC 890-930
157	6SE7042-4UR20	2450,0	DC 675-780
158	6SE7042-4WR20	2450,0	DC 890-930
159	6SE7042-5UR20	2470,0	DC 675-780
160	6SE7042-5WR20	2470,0	DC 890-930
161	6SE7043-3UR20	3270,0	DC 675-780
162	6SE7043-3WR20	3270,0	DC 890-930
163	6SE7043-1UR20	3090,0	DC 675-780
164	6SE7043-1WR20	3090,0	DC 890-930
165	6SE7044-1UR20	4090,0	DC 675-780
166	6SE7044-1WR20	4090,0	DC 890-930
167	6SE7043-7UR20	3710,0	DC 675-780
168	6SE7043-7WR20	3710,0	DC 890-930
169	6SE7044-8UR20	4900,0	DC 675-780
170	6SE7044-8WR20	4900,0	DC 890-930
171	6SE7044-3UR20	4320,0	DC 675-780
172	6SE7044-3WR20	4320,0	DC 890-930
173	6SE7045-7UR20	5720,0	DC 675-780
174	6SE7045-7WR20	5720,0	DC 890-930
175	6SE7045-0UR20	4940,0	DC 675-780
176	6SE7045-0WR20	4940,0	DC 890-930
177	6SE7046-5UR20	6540,0	DC 675-780
178	6SE7046-5WR20	6540,0	DC 890-930
180	6SE7036-5US20	4940,0	DC 675-780
181	6SE7036-5WS20	4940,0	DC 890-930
182	6SE7038-6US20	6540,0	DC 675-780
183	6SE7038-6WS20	6540,0	DC 890-930

↓ P052 = 0 Function selection „return“

↓ P key The operating display appears, and when the MLFB has been changed, the following parameters are re-assigned:

- ◆ Equipment data and motor data (from the MLFB of the equipment (P070) determine), as well open-loop/closed-loop control parameters („automatic parameterization“ over **all** data sets as for function selection „factory setting“ (↔ Section 8.1.1)).
The process data connections (e.g. analog inputs/outputs are retained).

↓ SWITCH-ON INHIBIT (008) or READY TO SWITCH-ON (009) are displayed after initialization has been completed.

8.1.2.1 Download (P052 = 3)

Function: It is used to read and change all parameters using a PC at the basic drive converter interface SST1 or SST2.

Condition: „Download“ is possible in the FAULT (007), SWITCH-ON INHIBIT (008) or READY TO SWITCH-ON (009) statuses.

Procedure:

↓ P052 = 3 Function selection „Download“

↓ P key Operating display (021).

- ◆ All of the parameters can now be read and changed, independently of the selected control type etc. using a PC connected at the basic drive converter interface SST1 or SST2.

↓ P052 = 0 Function selection „Return“

↓ P key

↓ After return, the SWITCH-ON INHIBIT (008) or READY TO SWITCH-ON (009) is displayed.

8.1.3 Hardware configuration (P052 = 4)

Function: It is used to define option boards (SCB, TSY, CB, TB) in the electronics box of the drive converter.

Condition: The „hardware configuration“ is possible in the FAULT (007), SWITCH-ON INHIBIT (008) or READY TO SWITCH-ON (009) status.

Further, the bus coupling LBA (Local Bus Adapter) is required for the electronics box!

☞ Chapter „Options“ in the Operating Instructions, Part 1

Result: All parameters, which can be written into the „hardware configuration“ status („H“, ☞ righthand column in the „parameter list“, Chapter 11), can be changed.

Procedure:

↓ P052 = 4 Function selection „Hardware-configuration“

↓ P051 = 3 Access stage Expert mode (to change the following parameters)

↓ P090 = Board, slot 2 (To the **RIGHT** in the electronics box!!)

P091 = Board, slot 3 (To the **CENTER** in the electronics box!!)

Parameter values for P090/P091:

- 0: No option board
- 1: CB Communications board
- 2: TB Technology board (only P090)
- 3: SCB Serial communications board
- 4: TSY Digital tachometer and synchronization board

Slots in the electronics box		Boards
Left	Slot 1 (CU)	CU
Center	Slot 3 (options)	CB1 / SCB1 / SCB2 / (TSY, not for TB)
Right	Slots 2 (options)	CB1 / SCB1 / SCB2 / TSY / TB
NOTE		
<ul style="list-style-type: none"> ◆ Only one of each option board type may inserted in the electronics box. ◆ Technology boards (e.g. T300) must always be inserted at slot 2. When a TB board is used, a TSY board my not be inserted. ◆ If only one option board is used it must always be inserted at slot 2. ◆ Order numbers for option boards and their descriptions, are provided in the Chapter „Options“ in the Operating Instructions, Part 1. 		

- ↓ Additional parameters, depending on the option boards
(☞ associated Operating Instructions and parameter list, Chapter 11)
- ↓ Select one of the following:
- ↓ P052 = 5 Function selection „drive setting“ (☞ Section 8.1.4)
- or
- ↓ P052 = 0 return
- ↓ P key
- ◆ The operational display (r000) appears during which parameters and internal quantities are re-assigned depending on the function selection.
 - ◆ The hardware is initialized.
If a fault message F050/F070/F080 appears, ☞ Chapter 12 „Fault and alarm messages“.
- ↓ After the selected function has been completed, the SWITCH-ON INHIBIT (008) or READY TO SWITCH-ON (009) display appears.

8.1.4 Drive setting (P052 = 5)

Function: It is used to change the drive setting (drive converter/motor data, system data).

Condition: The „drive setting“ is possible in the FAULT (007), SWITCH-ON INHIBIT (008) or READY TO SWITCH-ON (009) status.

Result:

- ◆ All parameters, which can be written in the „drive setting“ status („A“, ↗ righthand column in the parameter list, Chapter 11) can be changed.
- ◆ After the drive setting has been completed, it can be decided as to whether the „automatic parameterization“ (P052 = 6), „motor identification at standstill“ (P052 = 7), „complete motor identification“ (P052 = 8) or „self test“ (P052 = 11) functions are to be executed, or just the status reset (P052 = 0) without any calculation of additional parameters.
- ◆ If fault F061 occurs when exiting the drive setting, the parameter number, which caused the fault, can be read in fault value r949.

Procedure:

- ⇓ P052 = 5 Function selection „drive setting“
- ⇓ P051 = 3 Access stage „expert mode“
(if parameters are to be changed, which require the expert mode)
- ⇓ Change the selected parameters, which can be written into the drive setting status.
- ⇓ Make a selection between the following:
 - either ⇓ P052 = 6 Function selection „automatic parameterization“ (↗ Section 8.1.5)
 - or ⇓ P052 = 7 Function selection „motor identification at standstill“ (↗ Section 8.1.6)
 - or ⇓ P052 = 8 Function selection „complete motor identification“ (↗ Section 8.1.6.1)
 - or ⇓ P052 = 11 Function selection „self test“ (↗ Section 8.1.9)
 - oder ⇓ P052 = 0 Function selection „return“
- ⇓ P key The operating display (r000) appears while parameters and internal quantities are re-assigned depending on the particular function selection.
- ⇓ After the selected function has been completed, the SWITCH-ON INHIBIT (008) or READY TO SWITCH-ON (009) function is displayed.

8.1.5 Automatic parameterization (P052 = 6)

Function: It is used to pre-assign open-loop/closed-loop control parameters, dependent on the selected drive setting (drive converter- and motor data) and open-loop/closed-loop control type (P163).

Condition: „Automatic parameterization“ can only be selected from the „drive setting“ status (P052=5).

Result: Only the parameters of the **currently** selected motor data set MDS can be pre-assigned!

Procedure:

- ⇓ P052 = 5 Function selection „drive setting“
- ⇓ P051 = 3 Access stage „expert mode“
(if parameters are to be changed, which require the expert mode)
- ⇓ P052 = 6 Function selection „automatic parameterization“
- ⇓ P key The operating display appears, while the following parameters are re-assigned:
 - If parameter P103 (no-load motor current) has the value 0.0%, the rated magnetizing current is calculated, and can be subsequently read via r196. Otherwise, the value is retained.

P168	Voltage boost
P169	Boost final frequency
P170	Field-weakening frequency
P172	IxR compensation Kp
P173	I _{max} (max. current value)
P185	Min. load-dependent flux
P189	Energization time
P191	Smoothing Psi(set)
P198	R(rotor) K _{tmp}
P215	Delta n(act., permissible)
P216	Smoothing n/f precontrol
P221	Smoothing n/f (act)
P225	n/f controller Kp
P229	n/f controller T _n
P242	Starting time
P243	n/f controller, precontrol Kp
P253	Current controller Kp
P254	Current controller T _n
P261	Smoothing I _{sq}
P272	R(stator + cable)
P287	EMF controller Kp
P289	EMF controller T _n
P294	Slip compensation Kp
P299	Resonant damping Kp
P300	Damping Kp
P312	Motor weight
P369	Restart-on-the-fly, search current
P371	De-excitation time
P770	Deadtime compensation
	„X(magnet)“
	„Smoothing I _{sq} (set)“
	„X(sigma)“
	„Transistor voltage compensation“

↓ After „automatic parameterization“ has been completed, the SWITCH-ON INHIBIT (008) or READY TO SWITCH-ON (009) operating display appears.

8.1.6 Motor identification at standstill (P052 = 7)

Function: This function executes „automatic parameterization“ (see Section 8.1.5) and then subsequently activates the ground-fault test, test pulse measurement, leakage measurement and carries-out the DC current measurement to improve the control characteristics. In so doing, the control parameters are re-assigned.

Condition: The „motor identification at standstill“ can be selected from the „drive setting“ (P052 = 5) or READY TO SWITCH-ON (009).

Result:

- ◆ Only the parameters of the **currently** selected motor data set MDS are pre-assigned!
- ◆ The „motor identification at standstill“ can be interrupted at any time using an OFF command. In this case, fault message F114 „measurement aborted“ is output.
- ◆ To display the actual measuring segment of the „motor identification at standstill“ the visualization parameter (display parameter) r333 „measurement section“ is available.
- ◆ If a fault/error occurs during measurement, the test is terminated with a fault message. The fault message (r947) is stored together with the fault value (r949) in the fault memory. The fault cause is described in detail in the fault value. The fault messages, fault values and alarm messages are described in Chapter 12 „Fault- and alarm messages“.

NOTE

The „motor identification at standstill“ is not possible when operating the drive converter with synchronous motors or for drive convertes with input voltages of between 500 V and 575 V with sinusoidal filter (option)!

Procedure:

↓ P052 = 7 Function selection, „motor identification at standstill“

↓ P key The operating display appears:
The alarm message A078 „standstill measurement follows“ is output, and the drive converter must be powered-up within 20 s. Otherwise, F114 fault trip „measurement aborted“ is output.

↓ Power-up the drive converter
Alarm message A078 „standstill measurement follows“ is reset.

NOTE

The inverter is enabled, current flows through the motor and the rotor can align itself!

↓ The operational display appears, while the following steps are automatically executed:

- ◆ „Automatic parameterization“ is called-up (see Section 8.1.5).
- ◆ Ground-fault test:

When the drive converter is operated from a grounded line network, a ground fault in the connected motor (including feeder cables) is identified, if the ground fault current $> 5\% \hat{I}_{\text{rated}}$ (drive converter). Further, defective transistors, which are still conductive, are identified in the inverter.

The tests consists of 7 steps. No transistor is fired in the 1st step, and in additional steps, precisely one transistor is fired.

In each step, the actual values of the output currents, phases U and W, the UCE checkback signals of the 3 phases, the overcurrent comparator, and the overvoltage comparator monitored.

The visualization parameter r358 (ground fault test result) is available, from which the measurement result which caused the fault, can be read-out.

Comment: The ground fault test can also be separately called-up using parameter 354 (ground-fault test).

- ◆ **Test pulses:**
These are used to check the inverter and the connection to the motor. The test result can be interrogated in visualization parameter r344 (test pulse result).
- ◆ **Leakage measurement:**
By injecting suitable voltage pulses, the referred total leakage $x(\sigma)$ of the connected motor is measured.
- ◆ **DC current measurement and the resulting parameter change:**
With the DC current measurement, a DC current is impressed in the individual drive converter output phases one after another.
In this case, a maximum DC current, having the magnitude of the peak rated motor current (max. rated drive converter current) is impressed. The drive converter pulse frequency is changed several times during the measurement.
At the start of the standstill measurement, all parameters are calculated by the „automatic parameterization“ (☞ Section 8.1.5).

Measured/calculated parameter values of the standstill measurement:

P103	No-load motor current
P189	Energization time
P198	R(rotor) K_{tmp}
P253	Current controller K_p
P272	R (stator + cable)
P287	EMFcontroller K_p
P289	EMFcontroller T_n
P371	De-energization time
P652	CU-AE offset (if an analog tachometer is connected)
r196	No-load current in A
r199	R(rotor)
r200	T(rotor)
r274	T(σ)
	„X(magnet)“
	„X(σ)“
	„Deadtime compensation time“
	„Transistor voltage compensation“

The measured values and the resulting calculated values, are only entered into the parameters after the DC current measurement has been correctly completed. If the measurement is aborted as a result of an off command or default, the parameter values, which were calculated at the start of the measurement in automatic parameterization, are kept.

- ⇓ The READY TO SWITCH-ON (009) operating display appears after the selected function has been completed.

8.1.6.1 Complete motor identification (P052 = 8)

Function: For vector control types (P163 = 3, 4, or 5), it is used to improved the control characteristics and includes the following functions:

- ◆ „Motor identification at standstill“ (includes „automatic parameterization“)
- ◆ „No-load measurement“ (includes „tachometer test“)
- ◆ „n/f controller optimization“

Condition: The „complete motor identification“ can be selected from the „drive setting“ status (P052 = 5) or READY TO SWITCH-ON (009).

Result:

- ◆ Only the parameters of the **currently** selected motor data set MDS or setpoint channel data set SDS are pre-assigned!
- ◆ The „complete motor identification“ can be terminated at any time using an OFF command. In this case, fault message F114 „measurement aborted“ is output.
- ◆ Visualization parameter r333 (measurement segment) is available to display the actual measurement segment of the „complete motor identification“. If an error occurs during the measurement, the test is aborted with an error message. Fault message (r947) is saved, together the the fault value (r949) in the fault memory. The cause of the fault is described in detail in the fault value. The fault messages, fault values and alarm messages are described in Chapter 12 „Fault- and alarm messages“.
- ◆ For P163 = 5 (closed-loop torque control), the unit is automatically changed over into the closed-loop speed control mode for the duration of the measurement.
- ◆ For P163 = 3 or 4 (closed-loop frequency/speed control and slave drive (refer to P587), the measurement is aborted (F096).
- ◆ Parameter P377 should be set to 1 (Vdmax controller on) if the drive converter has no possibility of regenerating (rectifier/regenerative feedback unit or brake resistor). However, if the drive converter still aborts the measurement with fault F006 (DC link overvoltage), the regenerative power should be limited to approx. -3 % to -0.1 % in parameter P233.

NOTE

The "motor identification at standstill" is not possible when operating the drive converter with synchronous motors or for drive converters with input voltages from 500 V to 575 V with sinusoidal filter (option)!

Procedure:

⇓ P452, P453 = Maximum frequencies

The drive speed during the measurement is limited to the parameter values for the maximum frequencies P452 (Rdf) and P453 (Ldf) in the actual motor data set. The maximum frequencies must be set before the measurement starts, so that a load possibly connected to the motor, is not damaged.

⇓ P492, P498 = Maximum torque during the measurement is limited to the parameter values for torque limits P492 (Mlimit 1) and P498 (Mlimit 2) in the actual motor data set.

The torque limits must be set before the measurement is started, so that a load, possibly connected to the motor, is not damaged.

⇓ P346 = ◆ Dynamic performance factor

Set the required dynamic performance (speed) of the speed controller (in %):
Whereby: 10 % (lowest) and 200 % (max. possible)
Note: Possible gearbox play, etc.

⇓ P052 = 8 Function selection, „complete motor identification“

- ↓ P key: The operating display appears:
Alarm message A078 „standstill measurement follows“ is output, and the drive converter must be powered-up within 20 s. Otherwise, the unit is fault tripped with F114 „measurement aborted“.

- ↓ Power-up the drive converter
Alarm message A078 „standstill measurement follows“ is reset.

NOTE

The inverter is enabled, current flows through the motor and the rotor can align itself!
--

- ↓ The operating display appears while the „motor identification at standstill“ function is being automatically executed (☞ Section 8.1.6).

- ↓ After the partial function has been completed, the READY TO SWITCH-ON (009) operating display appears alternating with alarm message A080 „rotating measurement follows“. The drive converter must be powered-up within 20 s, otherwise the unit is fault tripped and F114 „measurement aborted“ is output.

NOTE

When aborted at this point, the parameter changes of the previous „motor identification at standstill“ are saved.

Procedure ↓ Power-up the drive converter

Alarm message A080 „rotating measurement follows“ is reset.

NOTE

The inverter is enabled, current flows through the motor and the rotor rotates!

- ↓ The operating display appears while the following steps are automatically executed:
- ◆ „No-load measurement“ is called-up“ (☞ Section 8.1.7) including tachometer test for P163 = 4 or 5.
 - ◆ „n/f controller optimization“ is called-up“ (☞ Section 8.1.8).
- ↓ After the selected function has been completed, the READY TO SWITCH-ON (009) operating display appears

8.1.7 No-load measurement (P052 = 9)

Function: It is used, for vector control types (P163 = 3, 4, or 5) to improve the control characteristics and is a partial function of the „complete motor identification“ (☞ Section 8.1.7). The no-load motor current (P103, r196) and main motor reactance are set by the measurement.

Condition: The „no-load measurement“ can be selected in the READY TO SWITCH-ON (009) status.

Result:

- ◆ If closed-loop speed or torque control is selected (P163 = 4 or 5), a tachometer test is additionally executed, and when an analog tachometer is used, the analog tachometer calibration is set (P210).
- ◆ The maximum drive speed during the measurement is limited to the parameter values for the maximum frequencies P452 (RDF) and P453 (LDF).
- ◆ Only the parameters of the **currently** selected motor data set MDS are pre-assigned!
- ◆ The „no-load measurement“ can be aborted at any time using an OFF command; in this case, the fault message F114 „measurement aborted“ is output.
- ◆ If an error occurs during the measurement, a detailed description of the fault message as well as the fault value is provided in Chapter 12 „Fault- and alarm messages“!

Procedure:

↓ P052 = 9 Function selection „no-load measurement“

↓ P key The operating display appears:
Alarm message A080 „rotating measurement follows“ is output, and the drive converter must be powered-up within 20 s. Otherwise, the unit is fault tripped and F114 „measurement aborted“ is output.

↓ Power-up the drive converter
Alarm message A080 „rotating measurement follows“ is reset.

NOTE
The inverter is enabled, current flows through the motor and the rotor rotates!

↓ The operating display appears, while the following steps are automatically executed:

- ◆ „Ground-fault test“:
(only if selected via P354)
☞ Function „ground-fault test“ for „motor identification at standstill“, Section 8.1.6.
- ◆ „Tachometer test“:
If only the speed- or torque control (P163 = 4 or 5) is selected, in addition, a tachometer test is executed (☞ Section 8.1.10 „tachometer test“). When an analog tachometer is used, the analog tachometer calibration (P210) is set.
- ◆ „No-load measurement“:
In steady-state controlled operation, the following parameters are set from the measurement:
P103 no-load motor current in %
r196 no-load motor current in A
r200 T(rotor)
„X(magnet)“

↓ After the selected function has been completed, the READY TO SWITCH-ON (009) operating display appears.

8.1.8 n/f controller optimization (P052 = 10)

Function: For vector control types (P163 = 3, 4, or 5) it is used to improve the control characteristics and is a partial function of the „complete motor identification“ (see Section 8.1.6.1).

Condition: The „n/f controller optimization“ can be selected in the READY TO SWITCH-ON (009) status.

- Result:**
- ◆ The function defines the mechanical drive moment of inertia, and adjusts several dependent control parameters.
If closed-loop speed or torque control is selected (P163 = 4 or 5) a tachometer test is additionally executed.
 - ◆ For P163 = 5 (closed-loop torque control), for the duration of the measurement, the closed-loop speed control mode is automatically selected.
 - ◆ For P163 = 3 or 4 (closed-loop frequency/speed control and slave drive) (refer to P587), the measurement is aborted (F096).
 - ◆ If the drive converter has no possibility of regenerating (rectifier/regenerative feedback unit or brake resistor), then parameter P377 should be set to 1 (Vdmax controller on).
If the drive converter still aborts the measurement with fault F006 (overvoltage in the DC link, then the regenerative power should be limited to approx. -3 % to -0.1 % in parameter P233.
 - ◆ Only the parameters of the **currently** selected motor data set (MDS) or the setpoint channel data set SDS should be pre-assigned!
 - ◆ The „n/f controller optimization“ can be aborted at any time using an OFF command; in this case, fault message F114 „measurement aborted“ is output.
 - ◆ If a fault/error occurred during the measurement, a detailed description of the appropriate fault/error message as well as the fault value is provided in Chapter 12 „Fault- and alarm messages“!
 - ◆ The „n/f controller optimization“ automatically activates the „n controller pre-control“ (P243).

Procedure:

- ⇓ P452, P453 = Maximum frequencies
The drive speed during the measurement is limited to the parameter values for the maximum frequencies P452 (Rdf) and P453 (Ldf) in the actual motor data set. The maximum frequencies must be set before measurement is started, so that a load, possibly connected to the motor, is not damaged.
- ⇓ P492, P498 = Maximum torque
The torque during the measurement is limited to the parameter values for the torque limits P492 (Mlimit 1) and P498 (Mlimit 2) in the actual motor data set. The torque limits must be set before the measurement is started, so that a load, possibly connected to the motor, is not damaged.
- ⇓ P346 = Dynamic performance factor (speed factor)
Set the required dynamic performance of the speed controller (in %):
Whereby: 10 % (lowest) and 200 % (max. possible)
Note: Possible gearbox play, etc.
- ⇓ P052 = 10 Function selection, „n/f controller optimization“
- ⇓ P key The operating display appears:
Alarm message A080 „rotating measurement follows“ is output, and the drive converter must be powered-up within 20 s. Otherwise, the drive converter is fault tripped with F114 „measurement aborted“.
- ⇓ Power-up the drive converter
Alarm message A080 „rotating measurement follows“ is reset.

NOTE

The inverter is enabled, current flows through the motor, and the rotor rotates!

↓ The operating display appears, while the following steps are automatically executed:

- ◆ „Tachometer test“:
If only the closed-loop speed or torque control is selected (P163 = 4 or 5), a tachometer test is additionally executed (see Section 8.1.10 „Tachometer test“).
- ◆ „Controller optimization“:
By evaluating the torque- and speed characteristic after automatically executed speed setpoint changes, the drive moment of inertia is defined and the speed controller set. The measurement is executed several times one after another.
Parameters which are set:
 - P221 smoothing n/f(act)
 - P225 n/f controller Kp
 - P229 n/f controller Tn
 - P242 Starting time
(Accelerating time at rated torque from standstill up to the rated speed)
 - P243 n/f controller, pre-control Kp
 - P347 n/f controller dynamic performance (act)
 - P348 n/f controller, oscillation frequency
- ◆ Only if the ramp-up and ramp-down times (P462 / P464) are specified in seconds (P463 / P465 = 0):
If, during the measurement, it is determined, that the selected ramp-up and ramp-down times cannot be achieved with the specified torque limits, then these can be increased to the minimum possible times:
 - P462 ramp-up time
 - P464 ramp-down time
 - P467 protective RFG Kp (only for closed-loop frequency control: P163 = 3)

↓ After the function has been terminated, the READY TO SWITCH-ON (009) operating display appears, and the achieved dynamic performance of the speed controller (speed controller speed) is displayed in parameter P347 (n/f controller, dynamic performance (act)).
The achieved dynamic performance possibly deviates from the previously set setpoint (P346) (due to an extremely high moment of inertia, or a noisy speed actual value signal).

8.1.9 Self-test (P052 = 11)

Function: It involves the same function as the „motor identification at standstill“ (see Section 8.1.6), **however, no parameter values are changed.**

Condition: The „self-test“ can be realized in the status „drive setting“ (P052 = 5, see Section 8.1.4) or READY TO SWITCH-ON (009).

Result: The „self-test“ is therefore suitable to check the drive converter as well as the connected motor.

NOTE

- ◆ The „self-test“ is not possible for drive convertes with input voltages from 500 V to 575 V with sinusoidal filter (option!
- ◆ The inverter is enabled, current flows through the motor, and the rotor can align itself!
- ◆ Procedure and instructions, see Section 8.1.6 „motor identification at standstill“.

8.1.10 Tachometer test (P052 = 12)

Function: For vector control types with tachometer (P163 = 4 or 5), it is used to check the tachometer (analog tachometer and pulse encoder).

Condition: The „tachometer test“ can be realized in the READY TO SWITCH-ON (009) status.

Result:

- ◆ The „tachometer test“ can be aborted at any time using an OFF command. In this case, fault message F114 „measurement aborted“ is output.
- ◆ If a fault occurs during the measurement, a detailed description of the appropriate fault/error message as well as the fault value is provided in Chapter 12 „Fault- and alarm messages,,!

Procedure:

↓ P052 = 12 Function selection „tachometer test“

↓ P key The operating display appears.
Alarm message A080 „rotating measurement follows“ is output, and the drive converter must be powered-up within 20 s. Otherwise the drive converter is fault tripped and F114 „measurement aborted“ is output.

↓ Power-up the drive converter
Alarm message A080 „rotating measurement follows“ is reset.

NOTE

The inverter is enabled, current flows through the motor and rotor rotates!

↓ The operating display appears while the following tachometer fault is checked:

- ◆ For pulse encoders:
 - no tachometer signal
 - incorrect polarity of the tachometer signal
 - incorrect normalization of the tachometer signal (P209 (pulse encoder pulse number))
 - a pulse encoder track is missing.
- ◆ For analog tachometer:
 - no tachometer signal
 - incorrect tachometer signal polarity
 - incorrect tachometer signal calibration (P210 (Ana.tach. set.) or potentiometer when ATI is used (option))

The test result can be interrogated in visualization parameter r345 (tachometer test result).

↓ After the test has been successfully completed, the READY TO SWITCH-ON operating display appears (009).

9 Functions (software)

9.1 WEA (automatic restart)

Description:

The automatic restart function can be used for automatic fault acknowledgement and automatic power-up after a power failure (F008 „DC link undervoltage“) as well as to permanently activate the restart-on-the-fly function without operating personnel having to intervene.

For fault message F008 „DC link undervoltage“ (power failure):  Chapter 12 „Fault and Alarm Messages“

Parameter to set the automatic restart function:

P366	WEA selection	i001: MDS1 to i004: MDS4	0 to 3
<p>P366 = 0 (inhibited):</p> <p>WEA is inhibited.</p> <p>P366 = 1 (power failure acknowledgement after the power returns):</p> <p>Fault message F008 „DC link undervoltage“(power failure) is acknowledged, if this did not occur for an OFF- or INCHING command for motor identification MOTID.</p> <p>The converter is not automatically switched-in by the WEA.</p> <p>P366 = 2 (Drive restart after the power returns):</p> <p>Fault message F008 „DC link undervoltage“ (power failure), is acknowledged, if this did not occur for an OFF or inching command or for motor identification MOTID.</p> <p>If it has been acknowledged, a delay time P367 in (s), which can be parameterized has to expire in the status SWITCH-ON INHIBIT (008), until the drive is automatically restarted by WEA.</p> <p>If the restart-on-the-fly function is activated via control word bit 23 (Section 5.1), delay time P367 is ignored.</p> <p>The unit is only switched-in again if the ON command (control word bit 0) is still present after the power returns.</p> <p>Thus, the WEA function is not possible with a parameterized ON command (control word bit 0) via PMU or OP1!</p> <p>P366 = 3 (drive is always powered-up with automatic restart-on-the-fly circuit):</p> <p>As for P366 = 2, however, the restart-on-the-fly function is always activated, independent of control word bit 23 (Section 5.1).</p> <p>Delay time (P367) is ignored.</p> <p>The restart-on-the-fly function is activated each time the drive is powered-up, even if the power had not previously failed!</p> <p>A description of the additionally necessary settings for the restart-on-the-fly function is provided in Section „Restart-on-the-fly“.</p>			

P367	WEA delay time	i001: MDS1 to i004: MDS4	0 s to 650 s
<p>Delay time between the supply return and when the drive converter is restarted with the WEA function activated.</p> <p>The delay time is not effective for P366 = 3 or when control word bit 23 is set.</p>			

Alarm A065 (Automatic restart function active):

- The alarm is set by WEA after switch-on, and is reset after precharging has been completed.
- When the drive is started by the WEA, the pre-charging time is not monitored, so that fault F002 „DC link precharging fault“ can not occur.
- The converter can be manually shutdown with an OFF command during this switch-on phase.
 - ☞ Chapter 12 „Fault and Alarm Messages“.

Special cases:

- ◆ If the converter has an external auxiliary supply, a fault is acknowledged and the drive re-started although the supply is still faulted, dependent on parameter P366!
Alarm A065 „automatic restart active“ is continuously present until the supply returns!
- ◆ If additional faults/errors have simultaneously occurred in addition to fault message F008 „DC link undervoltage“ (power failure), these are also acknowledged, dependent on parameter P366 !
- ◆ If the kinetic buffering function is also activated, when the power fails, this is first executed, before fault trip F008 occurs and the WEA intervenes.

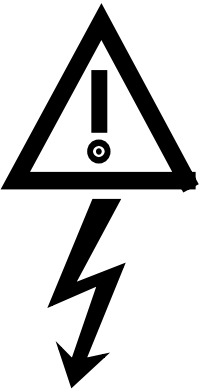
	WARNING
	<p>During power failures and activated WEA (P366 = 2, 3), the converter can automatically restart when the supply returns and after delay time P367 has expired (not valid when the restart-on-the-fly function is activated).</p> <p>Thus, the drive could be at a standstill for a longer period of time which could be accidentally mistaken for being switched-off.</p> <p>If the drive area is approached when in this status, severe bodily injury or material damage could occur.</p>

NOTE
<p>If the restart-on-the-fly function is not activated, and P366 = 2, overcurrent trip F011 could occur or the motor could be suddenly braked, when the converter is restarted and the motor is still rotating !</p> <p>Thus, delay time P367 must be selected high enough, so that it is guaranteed that the motor comes to a standstill before the switch-on command!</p>

9.2 KIP (Kinetic buffering)

Description:

The KIP function allows brief power supply failures to be buffered by utilizing the kinetic energy, i.e. inertia of the connected load.

In this case, the frequency is controlled (closed-loop), so that the system losses are covered by the over-synchronous motor operation.

As the losses remain during the power failure, the converter output frequency has to be lower. The thus reduced speed reduction must be taken into account.

When the supply returns, power is fed in from the supply, and the converter output frequency returns to the selected reference frequency via a ramp-function generator function (RFG).

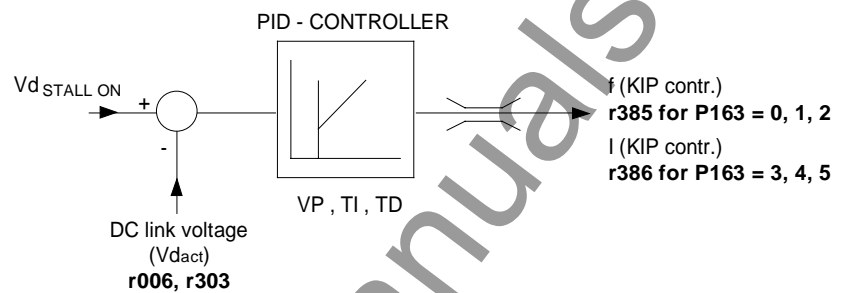

Fig. 9.1 Kinetic buffering

As long as the KIP function is switched-in, the „KIP active“ signal is set via **status word bit 15** (see Section 5.2).

Parameter to set the kinetic buffering function:

P379	KIP on/off	i001: MDS1 to i004: MDS4	0 to 3
0: Kinetic buffering is not enabled. 1: Kinetic buffering is enabled. 2: Flexible response is enabled with $V/f = \text{const}$. 3: Flexible response is enabled with $f = \text{const}$			
P380	KIP initiation point	i001: MDS1 to i004: MDS4	65 % to 115 %
The kinetic buffering threshold can be set between 65 % and 115 % using this parameter. The switch-off threshold is 5 % above the switch-on threshold (see Chapter 10 „Function diagrams“). For closed-loop frequency/speed/torque control (P163 = 3, 4, 5), fault message F008 „DC link undervoltage“ is disabled, if: <ul style="list-style-type: none"> • 61 % V_d rated is fallen below or • 10 % of the rated motor frequency (P107) is fallen below or • only for closed-loop frequency control (P163 = 3): the closed-loop control changes into the „current model“ range (r286 from 1 „EMF model“ to 0 „current model“) 			
NOTE			
For kinetic buffering, values for P380 > 90 % are only practical, if an active front end (AFE) is used as rectifier/regenerative feedback unit.			

P381	KIP controller dynamic	i001: MDS1 to i004: MDS4	0 % to 200 %
<p>The characteristics of the PIB controller can be influenced using this parameter. The factory setting is 50 %. At 0 %, the kinetic buffering function is disabled. The controller output can be visualized via parameters r385 or r386.</p>			

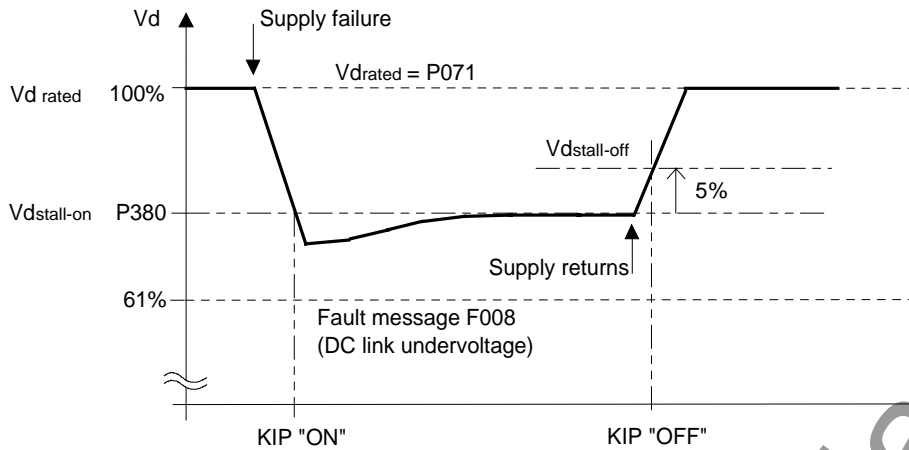

Fig. 9.2 Switch-on/switch-off threshold

$$V_{d \text{ KIP ON}} = P380 \times V_{d \text{ rated}}$$

Pre-assign: P380 = 76 %

$$V_{d \text{ KIP-OFF}} = (P380 + 5\%) \times V_{d \text{ rated}}$$

Pre-assign: bei P380 = 76 % ⇒ 81 %

$$V_{d \text{ rated}} = 1,315 \times P071$$

9.3 Flexible response

Description:

The „flexible response“ function allows the converter to still operate during supply dips up to a minimum DC link voltage of 50% of the rated value. The maximum converter output is decreased corresponding to the actual line supply voltage. If the „flexible response“ function is enabled, the firing level is limited to the range of the asynchronous vector modulation (reduction of the max. output voltage).

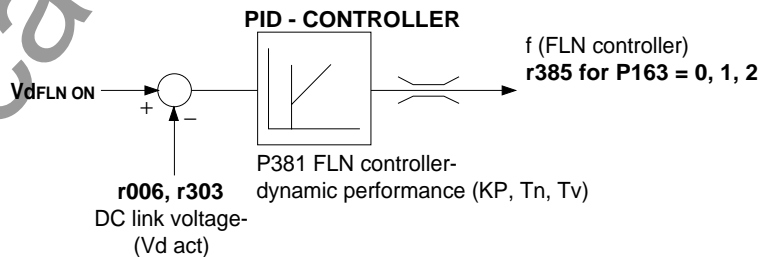

Fig. 9.3 Flexible response

NOTE
<p>The maximum firing level can be taken from parameter r180. The maximum output voltage at the particular operating point can be read-out at parameter r181.</p>

The „FLR active“ signal is set via the **status word bit 15**, (see Section 5.2) as long as the „flexible response“ function is active.

Conditions:

- ◆ A line commutating reactor von 4 % must be provided.
- ◆ The electronics power supply must be realized using an external 24 V supply at connector X9 (see Chapter "Connecting-up" in the Operating Instructions, Part 1).
- ◆ It must be ensured, that if there is an external main contactor, this does not drop-out during the supply dip.
- ◆ When the line voltage supply returns, it is not permissible that the voltage increases 50% to 100% in less than 5 ms.
- ◆ A maximum of 10 dips/hour are permissible with a minimum 10 s time between them.

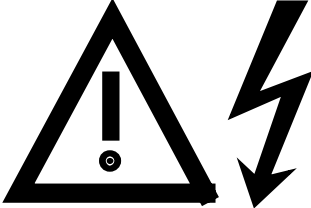
	WARNING
	If these conditions/instructions are not observed, this can result in erroneous function or the drive converter being destroyed.

During a supply dip, the available induction motor output is reduced

- approximately linear for vector control operation,
- over-proportionally for operation with one of the V/f operating modes (P163 = 0,1,2)

Parameter to set the flexible response function:

P379	FLR on/off	i001: MDS1 to i004: MDS4	0 to 3
0: Flexible response is not enabled. 1: Kinetic buffering is enabled. 2: Flexible response is enabled with V/f = const. 3: Flexible response is enabled with f = const. (only for v/f operation P163 = 0, 1, 2).			

P380	FLR initiation point	i001: MDS1 to i004: MDS4	65 % to 115 %
The FLN threshold can be set to between 65% and 115% using this parameter. The switch-off threshold is 5% above the switch-on threshold (see Chapter 10 „Function diagrams“).			
NOTE			
For flexible response, values of P380 > 90 % are not practical, as otherwise the function may not be able to be switched-out. When using an active front end (AFE) as rectifier/regenerative feedback unit, the FLN function is automatically included in the AFE.			

P381	FLN controller dynamic performance	i001: MDS1 to i004: MDS4	0 % to 200 %
The characteristics of the PID controller can be changed using this parameter. The FLN controller is only enabled for V/Hz open-loop/closed-loop control types (P163 = 0, 1, 2) and P379 = 2. The controller ensures that the V/f ratio remains constant. For supply dips/interruptions, the drive converter output frequency and therefore the motor speed can decrease. The factory setting is 50 %. The controller output can be visualized via parameter r385 .			

P387	FLN Vdmin	i001: MDS1 to i004: MDS4	50 % to 76 %
Using this parameter, the voltage threshold of the fault message F008 (DC link undervoltage) can be reduced from 76 % (factory setting!) to 50 % (see Chapter 10 „Function diagrams“).			

P189	Energization time	i001: MDS1 to i004: MDS4	0.01 s to 10.00 s
If field weakening is reached during voltage dips, then, for V/Hz open-loop control types (P163 = 0, 1, 2), when the voltage returns, the output voltage is ramped-up which corresponds to twice the excitation time. The excitation time is calculated during automatic parameterization (P052 = 6) and motor identification (P052 = 7, 8).			

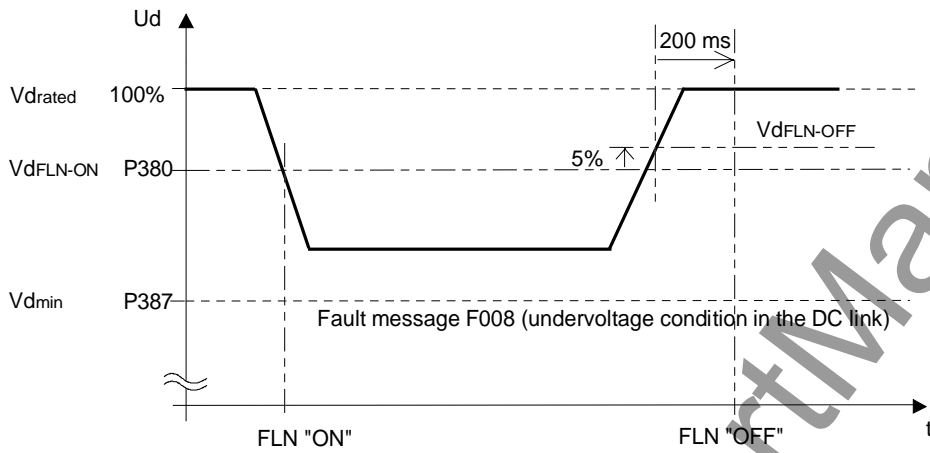

$$V_{d \text{ FLN ON}} = P380 \times V_{d \text{ rated}} \quad \text{Pre-assigned: } P380 = 76 \%$$

$$V_{d \text{ FLN OFF}} = (P380 + 5\%) \times V_{d \text{ rated}} \quad \text{Pre-assigned: for } P380 = 76\% \Rightarrow 81 \%$$

$$V_{d \text{ min}} = P387 \times V_{d \text{ rated}}$$

$$V_{d \text{ rated}} = 1.315 \times P071$$

Fig. 9.4 Flexible response

9.4 Vdmax closed-loop control

Description:

The Vdmax closed-loop control function allows briefly occurring regenerative loading to be handled without the unit shutting down with fault F006 (DC link overvoltage). In this case, the frequency is controlled (closed-loop), so that the motor does not excessively enter over-synchronous operation.

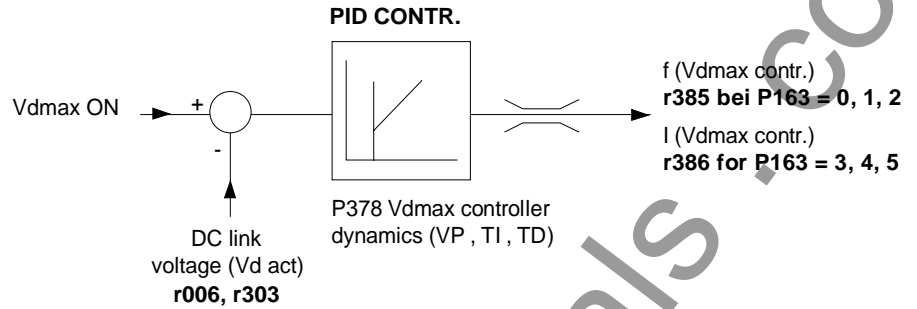

Fig. 9.5 Vdmax closed-loop control

For a steady-state load, the converter output frequency must increase. If a regenerative load exists for too long, the unit is shutdown with F006 when the maximum frequency is reached (P452, P453). If regenerative loading occurs when the machine is decelerating too quickly (P464), then this is automatically reduced, so that the converter is operated at the voltage limit.

The Vdmax control is also optimally suited for regenerative operation, which can occur when the speed stabilizes at the end of ramp-up.

Parameters to set the Vdmax closed-loop control:

P377	Vdmax controller on/off	i001: MDS1 to i004: MDS4	0 to 1
0: The Vdmax controller is inhibited. 1: The Vdmax controller is enabled.			
P378	Dynamic performance of the Vdmax controller	i001: MDS1 to i004: MDS4	0 % to 200 %
The characteristics of the PID controller can be influenced using this parameter. For 0 %, the Vdmax controller is disabled. The factory setting is 50 %. The controller output can be visualized via parameters r385 and r386.			

Alarm A041 „Vdmax controller inhibited“:

The line supply voltage is too high or the drive converter supply voltage (P071) is incorrectly parameterized. The Vdmax controller is inhibited in spite of the fact that the parameter is enabled (P377 = 1), as otherwise, the motor would immediately accelerate to the maximum frequency in operation.

The response threshold when inhibiting the Vdmax controller is calculated as follows:

$$V_{d \text{ max-ON}} = 119 \% \times \sqrt{2} \times V_{\text{supply, rated}} = 168 \% V_{\text{supply, rated}}$$

$$V_{\text{supply, rated}} = P071 \text{ for AC - AC drive converters and}$$

$$V_{\text{supply, rated}} = \frac{P071}{1.315} \text{ for DC - AC drive converters}$$

9.5 Setting the short-time overload capability

The setpoint for the current limiting controller is set in parameter 173. The maximum current can be parameterized up to 160 % $I_{conv.N}$:

- Voltages 208 ... 230 V, 380 ... 460 V and 500 ... 575 V
- Frame sizes A to H: 2.2 ... 200 kW

Additional boundary conditions are:

- ◆ A vector control type (P163 = 3, 4 or 5) selected
- ◆ No output filter (P092 = 0) connected
- ◆ The DC link voltage is not exceeded for
 - $1.32 \times 1.2 \times V_{supply,max}$ (AC units)
 - $1.2 \times V_{DC}$ (DC units)

If a maximum current > 136 % is set, the permissible load duty cycle changes as follows:

- $I_{max} \leq 136\%$: $I_{max} = 136\%$ for 60 s, $I_{max} = 91\%$ for 240 s
- $I_{max} > 136\%$: $I_{max} = 160\%$ for 30 s, $I_{max} = 91\%$ for 270 s

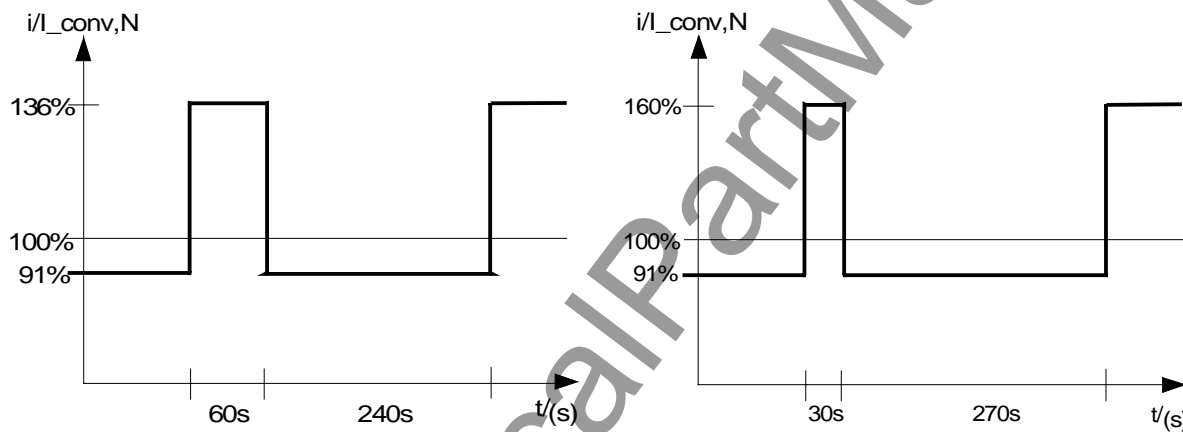

Fig. 9.6 Permissible load duty cycles

If a maximum current of >136% is demanded by the load, the control range is automatically limited to the vector modulation, i.e. the fully output voltage is no longer available.

NOTE

For longer output cables, sporadic overcurrents can occur (alarm A020, fault message F011).

9.6 DC current brake

Description:

The DC brake function allows the drive to be brought to a standstill in the shortest possible time. To realize this, a DC current is impressed in the motor windings, which, for an induction motor, results in a very high braking torque.

NOTE

The „DC current braking“ function is only practical for induction motors!

With the „DC current braking“ function, the kinetic energy of the motor is converted into heat **in the motor**. The drive could overheat if it remains in this status for an excessive period of time!

Parameters to adjust the DC current brake:

P371	Motor de-energization time	i001: MDS1 to i004: MDS4	0,01 s to 10,00 s
The minimum delay time between pulse inhibit and pulse enable is set using the parameter. Thus, it should be ensured that the motor is at least de-magnetized to 90% when the pulses are enabled. The parameter is pre-assigned during automatic parameterization and motor identification.			
P372	DC brake on/off	i001: MDS1 to i004: MDS4	0 to 1
0: DC brake on/off. 1: The DC brake is not activated for an OFF3 command (fast stop), the unit is DC current braked.			
P373	DC braking current	i001: MDS1 to i004: MDS4	20 % to 400 %
The current setpoint (as a %, referred to the rated motor current) is set using this parameter, which is impressed for DC current braking			
P374	DC braking duration	i001: MDS1 to i004: MDS4	0.1 s to 99.9 s
The DC current braking duration is adjusted using this parameter.			
P375	Frequency at the start of DC braking	i001: MDS1 to i004: MDS4	0.1 Hz to 600.0 Hz
For an OFF3 command, DC current braking is realized from this frequency.			

Procedure:

- ◆ The DC brake is activated using the OFF3 command.
- ◆ The drive converter decelerates along the parameterized OFF3 ramp (P466) down to the frequency for the start of DC braking (P375). Thus, the motor kinetic energy can be reduced without endangering the drive. However, if the OFF3 ramp-down time (P466) is selected to be too low, there is a potential danger that a fault could occur due to DC link overvoltage (F006).
- ◆ The inverter pulses are inhibited for the duration of the de-energization time (P371).
- ◆ The required current (P373) is then impressed for the selected braking duration (P374).
- ◆ The drive converter changes into the SWITCH-ON INHIBIT (008) or READY TO SWITCH-ON (009) status.

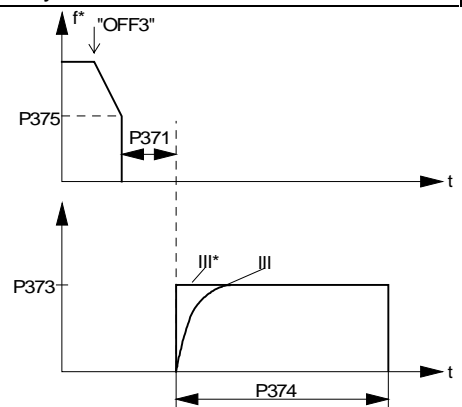

Fig. 9.7 DC current braking

9.7 Restart-on-the-fly

Description:

The restart-on-the-fly function allows the converter to be connected to a motor which is still rotating. If the converter was to be switched-on without the restart-on-the-fly function, an overcurrent condition would occur, as the flux in the motor has to first be built-up, and the open-loop/closed-loop control must be appropriately set.

NOTE
It is not possible to implement a restart-on-the-fly function for multi-motor drives, as the motors have different run-down characteristics!

The following is executed, depending on whether a tachometer is enabled:

Restart-on-the-fly without tachometer (with search) (P208 = 0):

NOTE
„Restart-on-the-fly without tachometer“ (searching) is only practical for induction motors! For „restart-on-the-fly without tachometer“, the „Standstill test“ generates a braking torque which can cause drives with low moments of inertia to be braked to a standstill.

- ◆ A standstill test (a DC current is briefly impressed) is executed after the de-energization time (P371) has expired after the supply returns, with WEA (☞ Section 9.1) active, or since the last shutdown time with „OFF 2“ command (inverter inhibit).
- ◆ If it is identified that the motor is at standstill, energization and acceleration are started as for a standard start
- ◆ If motor standstill has not been identified, searching is started with the maximum frequency, clockwise phase sequence (P452); if only a COUNTER-CLOCKWISE phase sequence is selected (☞ Section 5.1 „Control word“), searching starts with the maximum frequency, clockwise rotating phase sequence (P453).
- ◆ The search frequency is linearly reduced down to 0 Hz, and more specifically by the search speed which can be parameterized **P370** (in Hz, referred to 1 second). In this case the search current **P369**, which can be parameterized, is impressed.
For P163=3 (closed-loop frequency control), the search current is limited to 200 % of the rated magnetizing current (r196).
 - **P163 = 1 or 2 (V/f characteristic):**
The reference output voltage of the drive converter required for the search current, is compared with the voltage value of the V/f characteristic corresponding to the search frequency.
When the motor frequency is found using this function, the search frequency is kept constant and the output voltage is changed to the voltage value of the V/f characteristic with the energization time constant (dependent on the energization time (P189)).
 - **P163 = 3 (closed-loop frequency control):**
The reference output voltage of the drive converter, required for the search current, is compared with the search frequency corresponding to the EMF setpoint.
If the motor frequency is found using this function, the search frequency is kept constant, and the flux setpoint is changed to the rated flux with the energization time constant (dependent on the energization time (P189)).

The ramp-function generator is then set to the search frequency.

If it is not possible to set the ramp-function generator, as the supplementary setpoint is too high, then the unit is shutdown with **Fault F018** „ramp-function generator could not be set at restart on the fly“. Otherwise the RESTART-ON-THE-FLY status (013) is exited and the motor (via the ramp-function generator) is ramped up to the actual setpoint frequency.

- ◆ If the motor was not found, at 0 Hz search frequency, a standstill test is again executed and a search run made in the appropriate direction of rotation when the phase sequence in the other direction of rotation is enabled. The motor is switched-in at 0 Hz even if the search was not successful.

Example: Restart-on-the-fly without tachometer (search)

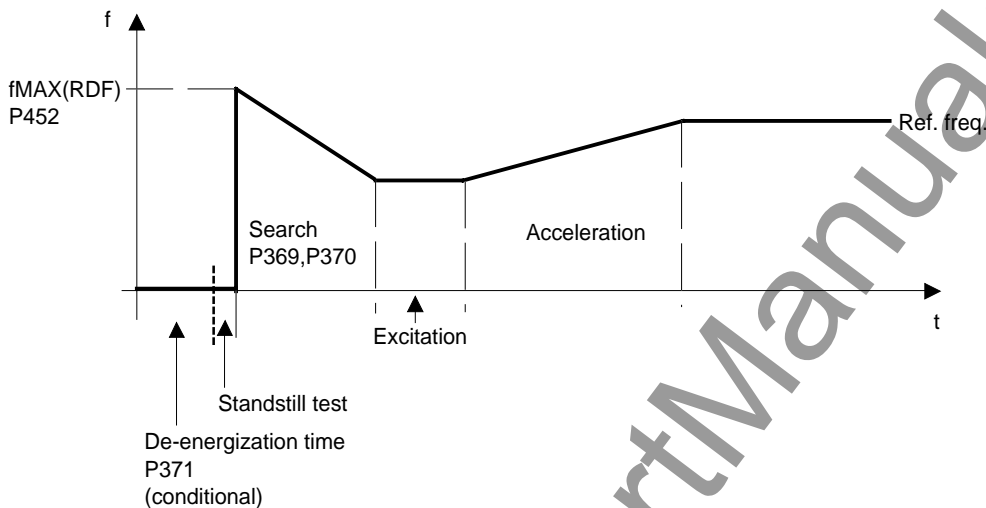

Fig. 9.8 Restart-on-the-fly

Restart-on-the-fly with tachometer (P208 ≠ 0):

- ◆ After the de-energization time has expired (P371), after the supply returns with activated WEA (Section 9.1) or an „OFF2“ command was applied since the last switch-off instant (inverter inhibit), then:
 - For V/Hz mode (open-loop control), the drive converter output voltage is linearly increased, within the energization time (P189) from 0 to the V/Hz characteristic value (determined from the measured, smoothed speed actual value).
 - For vector controls, the required magnetizing current is established within the energization time.
- ◆ After the energization time (P189) has expired, the ramp-function generator is set to the smoothed speed actual value.

If it is not possible to set the ramp-function generator, because the supplementary setpoint is too high, then the unit is shutdown with **Fault F018** „ramp-function generator was not able to be set for restart-on-the-fly“.
- ◆ Otherwise, RESTART-ON-THE-FLY status (013) is exited, and the motor is ramped up to the actual setpoint frequency (via the ramp-function generator).
- ◆ For closed-loop torque control (P163 = 5) or a slave drive (refer to P587), the drive continues with the actual torque setpoint

Parameter to select the restart-on-the-fly function:

P583 Control word bit 23	Restart-on-the-fly enable	i001: BASIC i002: RES	0 to 1
<p>0: Restart-on-the-fly is not enabled. 1: Restart-on-the-fly is enabled at each on command. Source selection parameter for control word bit: P583 ↗ Section 5.1 „Control word“.</p> <p>Exception: P366 = 3 The automatic restart (↗ Section 9.1) and restart-on-the-fly (without taking into account the control word command „restart-on-the-fly enable“ (bit 23)) functions are always activated.</p>			

Only for restart-on-the-fly without tachometer (with search) (P208 = 0):

P369	Restart-on-the-fly search current	i001: MDS1 to i004: MDS4	10 % to 400 % (for closed-loop frequency control, max. 2×r196 realized)
<p>Setpoint of the impressed current when searching for the motor (as a %, referred to the rated motor current (P102)) Presetting during „automatic parameterization“ to „no-load motor current“ (r196)</p>			
P370	Restart-on-the-fly search speed	i001: MDS1 to i004: MDS4	0.1 Hz to 100.0 Hz
<p>Ramp gradient with which the search frequency can be changed (in Hz, referred to 1 second).</p>			

As long as the restart-on-the-fly function is active, the „**restart-on-the-fly active**“ message is set via the **status word bit 16** (↗ Section 5.2).

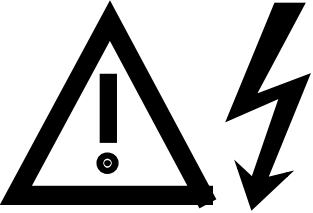
	WARNING
	<p>With the „restart-on-the-fly without tachometer“ activated (P366 = 3 with WEA or control word bit 23), the drive may suddenly accelerate as a result of the search current in spite of the fact that the drive is at a standstill and a 0 Hz setpoint !</p> <p>Death, severe bodily injury or material damage can occur if the drive area is entered!</p>

9.8 Technology controller

Description:

The technology controller function can be used for simple, higher-level closed-loop control functions without requiring an additional technology board (TB)

A freely connectable setpoint is compared with a freely connectable actual value, and the output is tracked via a parameterizable controller characteristic.

The technology controller sampling time is $8 \times P308$ (pre-setting 9.6 ms).

The technology controller computes in the PZD notation, i.e. 100 % corresponds to 4000 0000H.

The function diagram of the technology controller is provided in Chapter 10.

Parameters to set the technology controller:

◆ Enable:

P584 Control word bit 24	Source, technology controller enable	i001: BASIC i002: RES	0 to 6004
Value 0: Technology controller is not enabled Value 1: Technology controller is enabled, if P526 or P531 \neq 0 additional possible settings, see Section 5.1			

◆ Technological setpoint:

P525	Fixed technological setpoint	i001: BASIC i002: RES	-200 % to 200 %
This value is active for P526 = 1001			
P526	Technological setpoint source	i001: BASIC i002: RES	0 to 6045
Source of the technological setpoint (possible settings, refer to Section 5.3)			
P527	Technological setpoint gain	i001: BASIC i002: RES	-300 % to 300 %
Is not valid for technological controller setpoint input via a fixed setpoint (P526 = 1001)			
P528	Setpoint smoothing		0.00 s to 600.00 s
Smoothing time constant of the setpoint (to prevent setpoint steps)			
r529	Actual technological setpoint		
Visualization parameter for the actual technological setpoint in %.			

◆ **Technological actual value:**

P530	Technological actual value	i001: Value 1 i002: Value 2	0 to 999
Internal sources for the technological actual values. The parameter number of the internal drive converter quantity is specified here, which is to be used as technological actual value.			
P531	Source, technological actual value	i001: BASIC i002: RES	0 to 6045
P531 = 1100: Internal technological actual value 1 (= contents of P530.1) P531 = 1200: Internal technological actual value 2 (= contents of P530.2) Additional possible settings, refer to Section 5.3			
P532	Gain, technological actual value	i001: BASIC i002: RES	-300 % to 300 %
Gain of the technology controller actual value			
P533	Smoothing, technological actual value		0.00 s to 600.00 s
Smoothing time constant of the actual value (to prevent actual value steps)			
r534	Actual technological actual value		
Visualization parameter for the actual technological actual value in %.			

◆ **Setpoint/actual value comparison:**

A binary status bit is generated from the comparison between the technological setpoint and the technological actual value; this can be visualized in status word 2, bit 27.
The status „connection“ is realized via parameter P627.

	Technological setpoint, positive	Technological setpoint, negative
HIGH	Techn. actual value > technological setpoint	Techn. actual value < technological setpoint
LOW	Techn actual value < techn. setpoint – hysteresis (P535)	Techn. actual value > techn. setpoint + hysteresis (P535)
P535	Hysteresis of the comparison	0.0 % to 100.0 %
Hysteresis for the „technological setpoint reached“ message. The hysteresis is only effective if the message is withdrawn.		
r536	Technological controller error signal	
Control error signal at the input of the technological controller in %.		

◆ **PID controller:**

Depending on the particular application, the controller can be operated as pure controller, as PD controller, as PI controller or as PID controller.

The controller is active, if the inverter pulses are enabled, the energization time (P189) has expired, and the technological controller has been enabled (control word bit 24=1, „connection“ via P584).

P537	Technological controller gain (P component)	0.00 to 250.00
-------------	---	----------------

P538	Technological controller integral action time (I component)	0.00 s to 600.00 s
The I component can be disabled using the value „0“.		

P539	Technological controller rate time (D component)	0.00 s to 300.00 s
The D component can be disabled using the value „0“.		

r540	Technological controller output signal	
Output signal of the technological controller before the limit value stage in %.		

P541	Technological controller limit 1	-200.000 % to 200.000 %
Upper limit of the controller output signals.		

P542	Technological controller limit 2	-200.000 % to 200.000 %
Lower limit of the controller output signal.		

P543	Technological controller ramp-function generator for limit 1	0.00 s to 100.00 s
Ramp-function generator for the upper limit value of the output signal.		

P544	Technological controller ramp-function generator for limit 2	0.00 s to 100.00 s
Ramp-function generator for the lower limit value of the output signal.		

r545	Limited technological controller output signal	
Output signal of the technological controller after the limit value stage in %.		
If limiting is active, the I component of the PI controller is held, in order to permit that the controller quickly leaves the limit.		

The technology controller output can then be connected with value 1020 to parameters **P226 (S.n/f reg. adap)**, **P433 (S.suppl.setpoint1)**, **P438 (S.suppl.setpoint2)**, **P443 (S.main setpoint)**, **P486 (S.torque setpoint)**, **P493 (S.torque limit1)**, **P499 (S.torque limit2)** and **P506 (S.torque/current suppl. setpoint)**.

Additional applications of the technology controller:

1. Using parameters P526 and r529 as well as P531 and r534, process data can be transferred from analog inputs or serial interfaces to supplementary boards.

Example:

Setpoints for a technological board are to be entered in word 05 and word 06 via SST1. In order to permit this, the parameterization must be as follows:

P526.1 = 2005 (word 05 from SST1)

P527.1 = 100.00 % (no gain)

P528 = 0.0 s (no smoothing)

P531.1 = 2006 (word 06 from SST1)

P532.1 = 100.00 % (no gain)

P533 = 0.0 s (no smoothing)

P694.2 = 529 (the actual value W02 for TB is thus word 05 from SST1)

P694.3 = 534 (actual value W03 for TB is thus word 06 from SST1)

The technological controller must not be activated for this function (P584 = 0).

2. Status bit 27 can be used as any comparator, by entering a comparison value via parameters P525 and P526, and a comparison quantity via P530 and P531.

The technological controller does not have to be activated for this function (P584 = 0).

9.9 Tracer

Description:

The trace function is used to quickly trace converter quantities/parameters (e.g. current, voltage, speed) in the converter itself. It has 8 channels, whereby all of the channels can operate independently of one another. Any quantity/parameter can be used as trigger- and trace quantity, which are accessible as parameter in the converter. It is **not** possible to record parameters from a technology board (TB) (parameter numbers > 1000 or d- or H parameters).

The trace memory size is approx. 28 kbyte which is dynamically distributed over the active trace channels, i.e., if, for example, 3 channels are activated, then 9.3 kbyte RAM memory is available for each channel.

Parameters to set the tracer:

As the tracer supports eight independent channels, the parameters, necessary for parameterization, are indexed 8x, whereby the channel number corresponds to the index number.

◆ Trigger event:

P735	TRC Trigger parameter	0 to 900
Parameter number of the signal which is to trigger the trace function.		
P736	TRC trigger value	0 to 65535
Parameter value in the PZD normalization, which is to be started or stopped during the trace.		
P737	TRC trigger condition	0 to 4
Trigger condition for the trace function		
0	Trigger parameter value < trigger value	
1	Trigger parameter value = trigger value	
2	Trigger parameter value > trigger value	
3	Drive converter goes into a fault condition	
4	Trigger parameter value ≠ trigger value	

Example: P735.1 = 1 (drive converter status, r001)
 P736.1 = 16 (off with fast stop)
 P737.1 = 1 (the same)
 Channel 1 of the tracer triggers when the fast stop is active (OFF3).

◆ Trace record:

P738	TRC actual values	0 to 999
Parameter number of the signal which is to be recorded from the trace channel.		
P739	TRC sampling time	1 to 200
Sampling time of the trace channel (as a multiple of the basic sampling time (P308))		
P740	TRC pre-trigger	0 % to 100 %
Percentage of the data, which are to be recorded before the trigger event.		

Example: P738.1 = 219 (speed actual value)
 P739.1 = 4 (trace sampling time)
 P737.1 = 40 (pretrigger)
 The speed actual value is sampled with 4×T₀ (T₀ = P308), whereby 40 % of the data in the trace memory are before the trigger event.

◆ **Trace start:**

P741	TRC start	0 to 1
<p>Start command for the trace channels. A trace channel can only be started, if it is completely parameterized. 0: Trace channel stopped 1: Trace channel started The parameter is automatically set to 0 again after a start, if the trace channel was triggered, and trace data have been read-in.</p>		

Reading-out trace data:

It is possible to read-out trace data via all of the drive converter interfaces. In this case, a differentiation must be made between digital and analog output.

◆ **Analog read-out** via analog outputs:

The parameter numbers of trace data parameters (r751 to r758) can be entered in the actual value parameters of the analog outputs (**P655 (CU-AA actual values)** and **P664 (SCI-AA actual values)**). The trace data are cyclically output at the relevant analog output. In this case, a trace data parameter **cannot** be simultaneously output via several analog outputs.

◆ **Digital read-out** is realized via SIMOVIS (refer to the corresponding documentation).

Normalization of the trigger value and trace data:

The associated PZD normalization is generally valid when entering the trigger value (P736) and for the trace data which are read-out. This means, that the trigger value must be entered in the PZD normalization of the trigger parameter (P375). Further, trace data are output in the PZD normalization of the recorded parameter P738). The same conditions are also valid for the analog output of a trace channel, as if parameters written with the trace, were to be directly output at the analog output.

Example:

Trace channel 2 should trigger, if the speed actual value (r214) is greater than 50 Hz. The frequency setpoint (r482) is to be recorded. The rated system frequency (P429) is 50 Hz.

Trigger parameter: P735.2 = 214

Trigger value: P736.2 = 16384 (r214 = 100 %, if r214 = P420; 100 % = 4000H = 16384)

Trigger condition: P737.2 = 2 (>)

Trace actual value: P738.2 = 482

Trace data read-out via r752 (for channel 2). The trace data are in the PZD normalization of parameter r482 (100 % = 4000H = P420).

NOTES

- ◆ Trigger conditions are compared without sign (**greater** and **smaller**). This must be taken into account, if signed parameters are to be triggered for negative trigger values.
- ◆ Due to the dynamic distribution of the trace memory, a previously inactive trace channel should not be parameterized or started, if another trace channel was triggered or the data of a trace channel is still to be read-out. When a trace channel is activated, the trace memory must be re-distributed. In this case, all data in the trace memory become invalid.
- ◆ For double-word parameters (type I4), the most significant word is always traced.
- ◆ Approx. 1% of the computation time is required per activated trace channel. This means, that if several trace channels are activated, it may be necessary to increase the sampling time (P308).

9.10 Temperature adaption

Temperature adaption is used in order to reduce the torque error for n/f/M closed-loop control or speed error for frequency control, which results from the temperature dependency of the stator- and rotor resistances.

The resistances are calculated using a complex thermal 3-mass model and, depending on the operating status, with an electrical motor model.

Temperature adaption can be activated for the three closed-loop vector control types (P163 = 3, 4, 5).

The electrical model only operates for closed-loop speed/torque control (P163 = 4, 5) and if there is a pulse tachometer (P208 = 1, 2). In this case, the following error correction P217 should be activated.

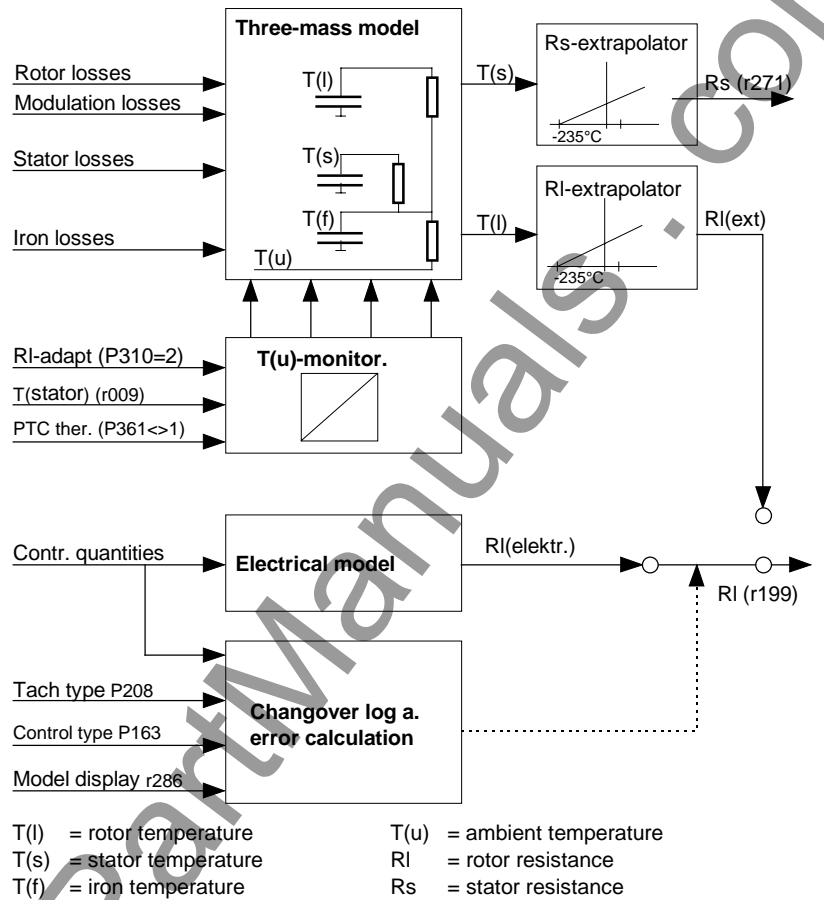

Fig. 9.9 Temperature adaption structure

Parameters to set the temperature adaption:

Basic settings

P310	RotResistTmpAdapt	i001: MDS1 to i004: MDS4	0 to 2
Temperature adaption of the rotor- and stator resistance. 0: Adaption inactive 1: Adaption without measuring the stator temperature 2: Adaption with KTY84 sensor available (connected at customer terminal X103 of the CU) For the temperature measurements (P310=2), the measuring quantity is displayed in r009 . A temperature sensor should be used if high demands are placed on the torque accuracy.			

P311 (motor series) can be adjusted after adaption has been activated (**P310** > 0). If the motor is included in the listed motor series, this should be selected. It is then automatically determined as to whether the motor has an internal fan and which temperature rise of the motor series it corresponds to. Parameters **P312**, **P313** and **P314** are then suppressed.

P311	Motorseries		(P313) Internal fan	(P314) Overtemperature
1	1LA5	⇒ determine	no	100 %
2	1LA6	⇒ determine	no	100 %
3	1LA8	⇒ determine	yes	100 %
4	1LA1	⇒ determine	yes	100 %
5	1PH6	⇒ determine	no	130 %
0	Unlisted motor	no determine	---	----

An unlisted motor is considered to be a motor from another manufacturer (**P311** = 0). In this case, parameters **P312**, **P313** and **P314** must be manually entered (refer to special settings).

P312	Motor weight	i001: MDS1 to 004: MDS4	5 kg to 999 kg
Gesamtgewicht des Motors			
The motor weight is estimated in the automatic parameterization from the motor output and pole pair number. For a more accurate calculation, the weight can also be taken from the motor catalog.			

If **P311** is reset for a known motor series, then motor weight **P312** is kept for the calculation. The ambient temperature at the motor identification time (P052=7, 8) should be entered in **P359**.

P362	Motor cooling	i001: MDS1 to 004: MDS4	0 to 1
0: Naturally-ventilated			
1: Forced-ventilated (internally automatically assumed, if P311 = 5)			

After the temperature adaption has been activated (**P310** = 1 or 2) and parameters **P311** to **P314** as well as **P359** and **P362** are assigned, a motor identification run (**P052** = 7, 8) must be executed in order to determine the actual rotor- and stator resistances.

For a more precise stator resistance adaption - especially for long feeder cables, before the motor identification run, the feeder cable resistance **P270** = R(cable), referred to the rated motor impedance, should be entered.

$$P270 = R_{cable} [\Omega] \times \frac{1.732 \times P102 [A]}{P101 [V]}$$

With activated temperature adaption (**P310** > 0), parameters **P198** „temperature evaluation rotor resistance“ and **P272** „stator- and feeder cable resistance“ should be inhibited for manual access. The adaption itself sets them. The result is displayed in **r199** and **r271**.

r199 Rotor resistance

r271 Stator resistance (incl. the feeder cable resistance **P270**)

At power failure, the actual adaption values are lost. When the supply returns, the values, determined for **P198** and **P272** during the last motor identification run (**P052** = 7 or 8) are used.

If the adaption values are to be kept even when the power fails, the electronic boards must be fed from a separate power supply.

When the adaption is exited (**P310** = 0), the last adaption values are transferred from **r199** and **r271** into parameters **P198** and **P272**. (only for **P310** = 1)

When adaption is exited with KTY (**P310** = 2) the values are not saved, because **P198** and **P272** are always referred to the ambient temperature **P359**.

It is recommended, necessary when adapting with a KTY sensor, that the motor identification run is executed with the motor in the cold condition, so that when the converter is powered-up after a longer down time, then the correct pre-assignment is automatically made. If there is a KTY sensor, the temperature model is correctly pre-assigned, even after a power failure.

Special settings

For sinusoidal operation (online operation or with an output filter, **P092** = 1), at the rated operating point (rated load, rated voltage, rated current, rated frequency), increased temperatures are obtained in the rotor and stator windings. The difference between these temperatures and the ambient temperature is known as the temperature rise and is specified in K (Kelvin).

The average temperature rises for the adaption are set to **100 K** for the rotor and **80 K** for the stator. For converter operation (pulse frequency 2.5 kHz, no output filter) an average rotor temperature rise of **110 K** is assumed.

If parameter **P314** „temperature rise factor“ is to be changed for a motor from a known series (e.g. 1LA5), then **P311** = **0** „unlisted motor“ must be entered so that parameters **P313** and **P314** are accessible. Parameter **P313** „internal fan“ should be assigned according to the table under the point „basic settings“.

If the actual motor temperature rises deviate significantly from the average temperature rises, the temperature rise can be corrected with P314. (100% = average temperature rise).

The factor to correct a temperature rise can be calculated according to one of the following formulas.

- ◆ Rotor temp. rise (sinusoidal operation),
$$P314 = \frac{\text{Rotor temp. rise (sinusoidal operation)}}{100 \text{ K}} \times 100 \%$$
- ◆ Rotor temp. rise (converter operation)
$$P314 = \frac{\text{Rotor temp. rise (converter operation)}}{110 \text{ K}} \times 100 \%$$
- ◆ Stator temperature rise
$$P314 = \frac{\text{Stator temperature rise}}{80 \text{ K}} \times 100 \%$$

www.ElectricalPartManuals.com

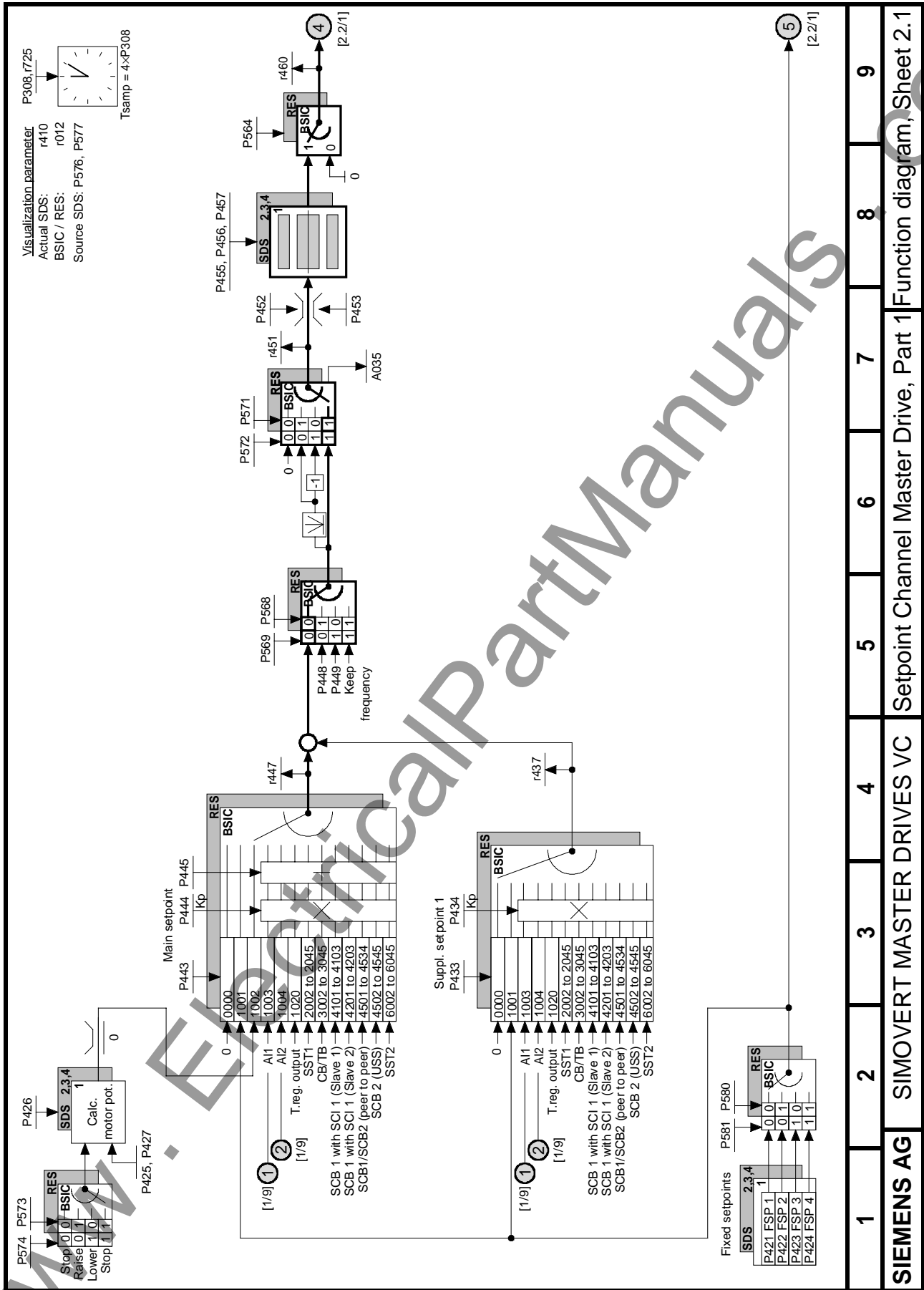

Fig. 10.2 Setpoint Channel Master Drive, Part 1

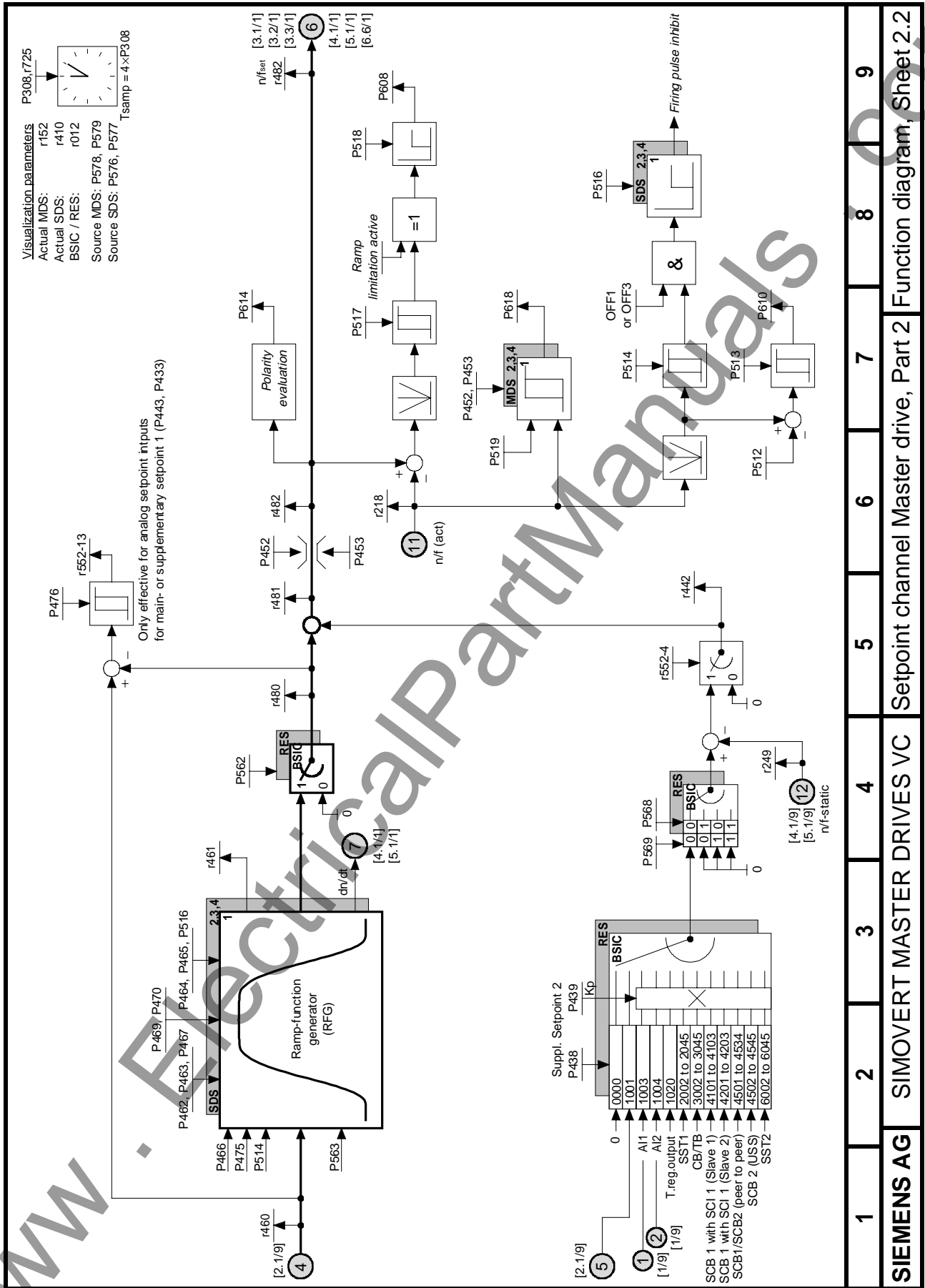

Fig. 10.3 Setpoint Channel Master Drive, Part 2

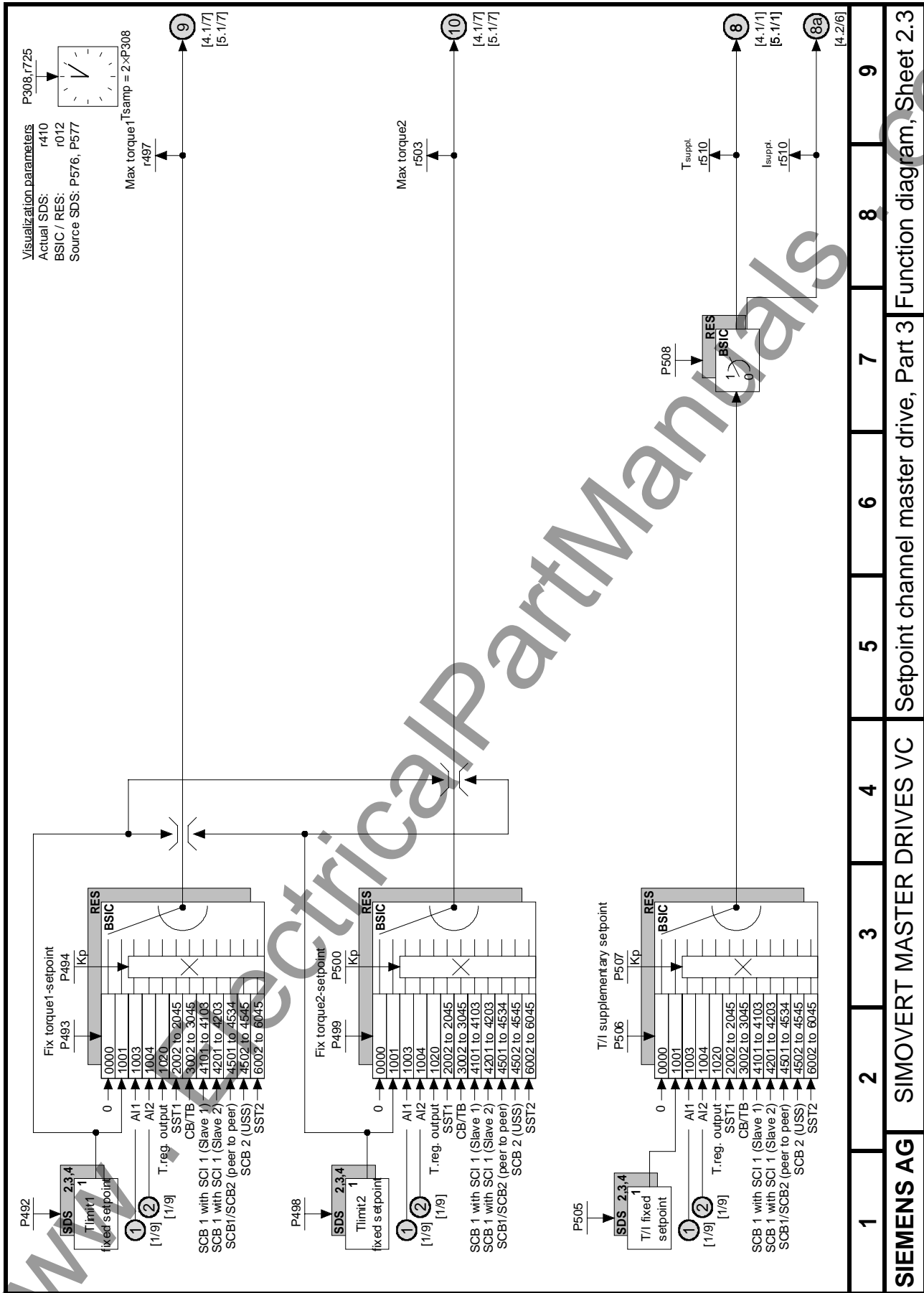

Fig. 10.4 Setpoint Channel Master Drive, Part 3

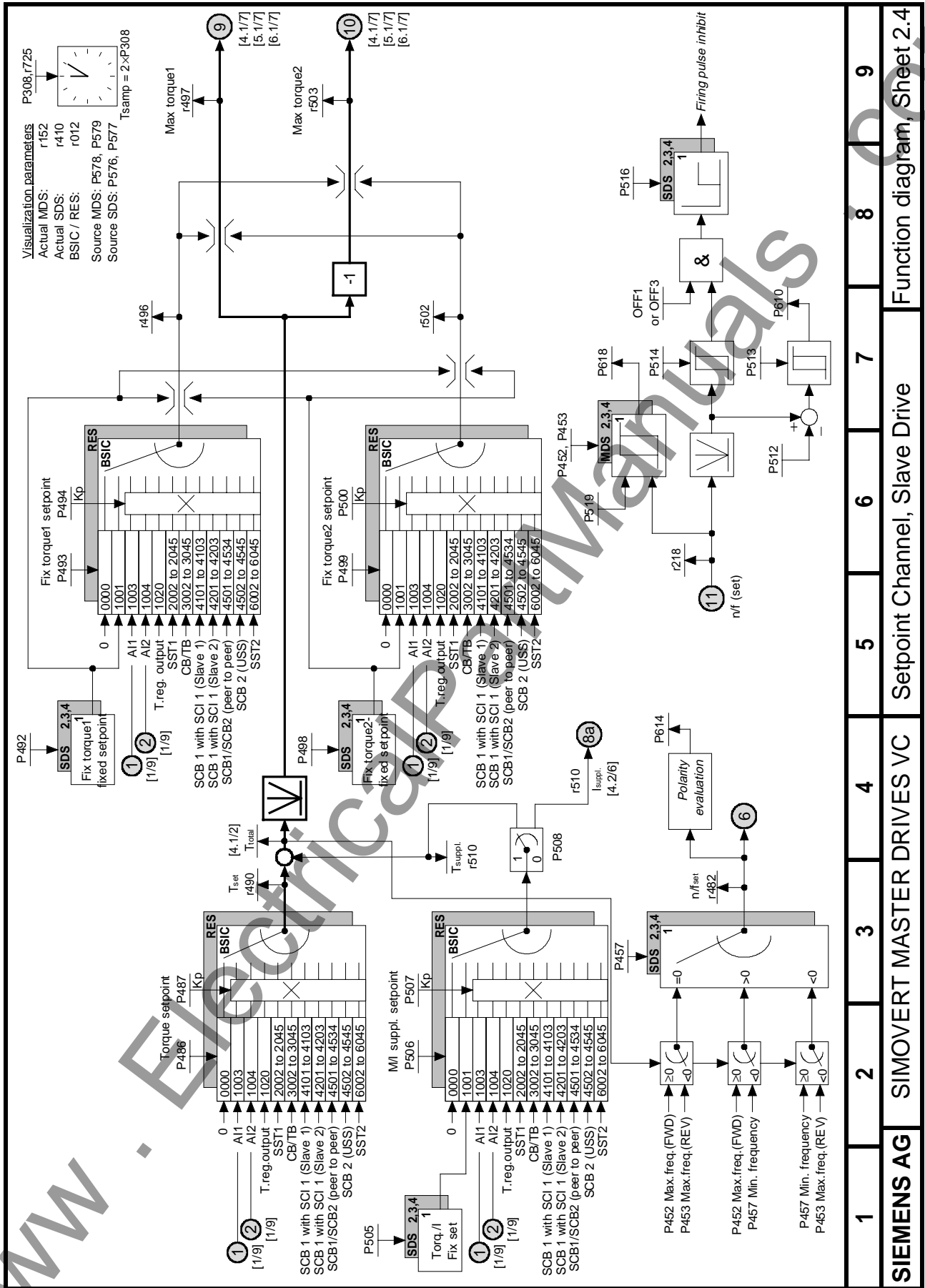

Fig. 10.5 Setpoint Channel Slave Drive

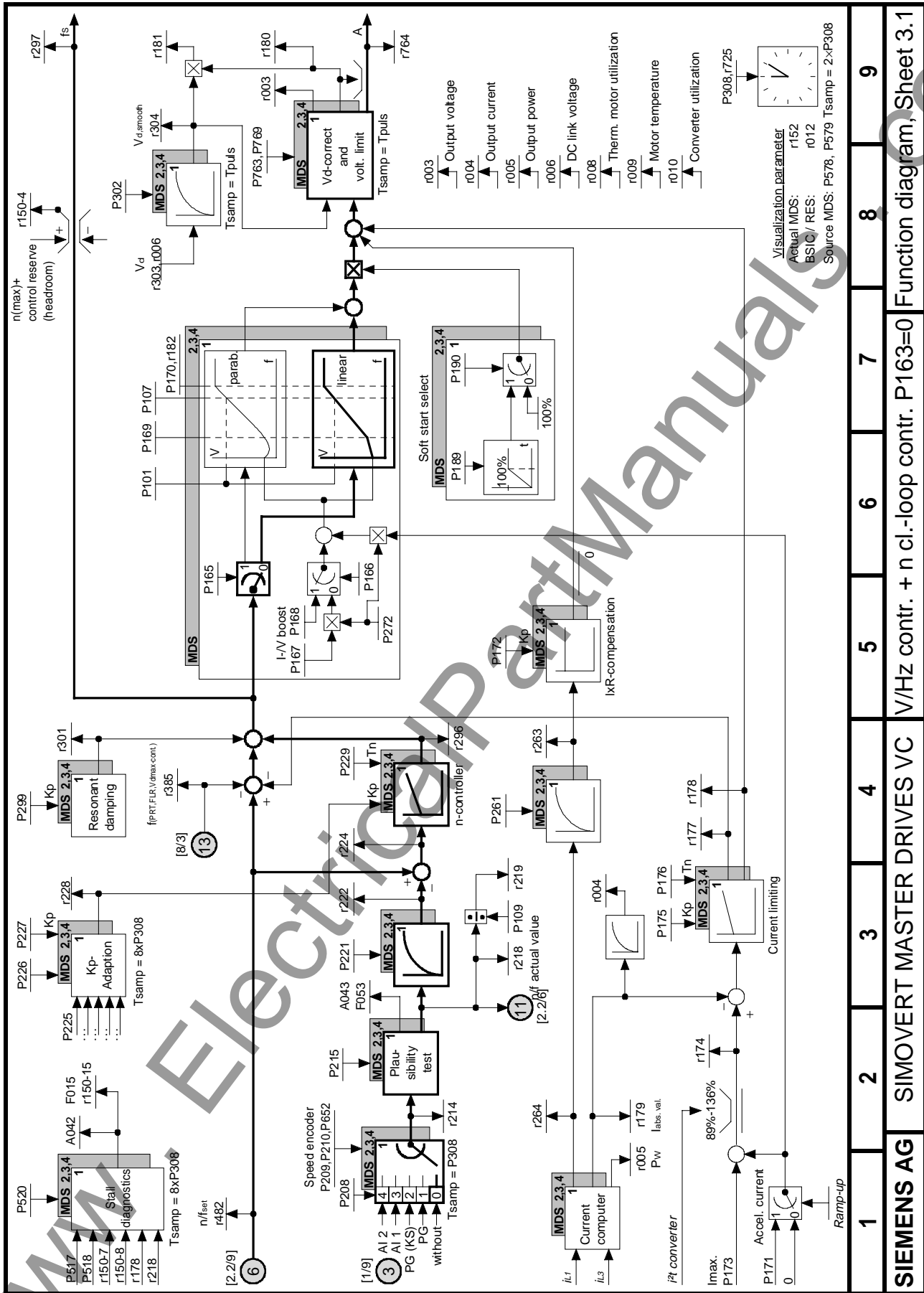

Fig. 10.6 V/Hz control + n closed loop control (P163 = 0)

1	2	3	4	5	6	7	8	9	
SIEMENS AG SIMOVERT MASTER DRIVES VC V/Hz contr. + n cl.-loop contr. P163=0								Function diagram, Sheet 3.1	

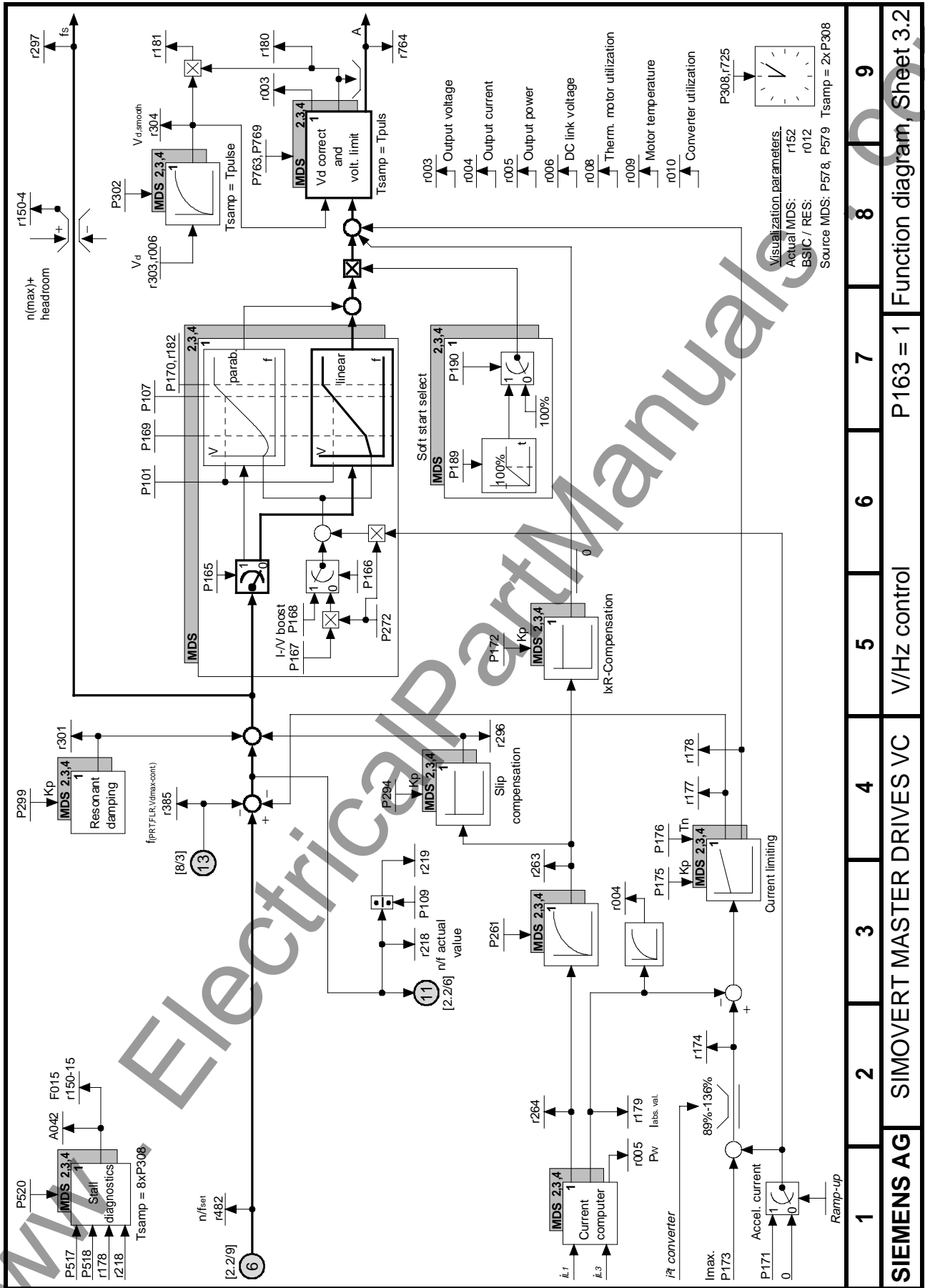

Fig. 10.7 V/Hz control (P163 = 1)

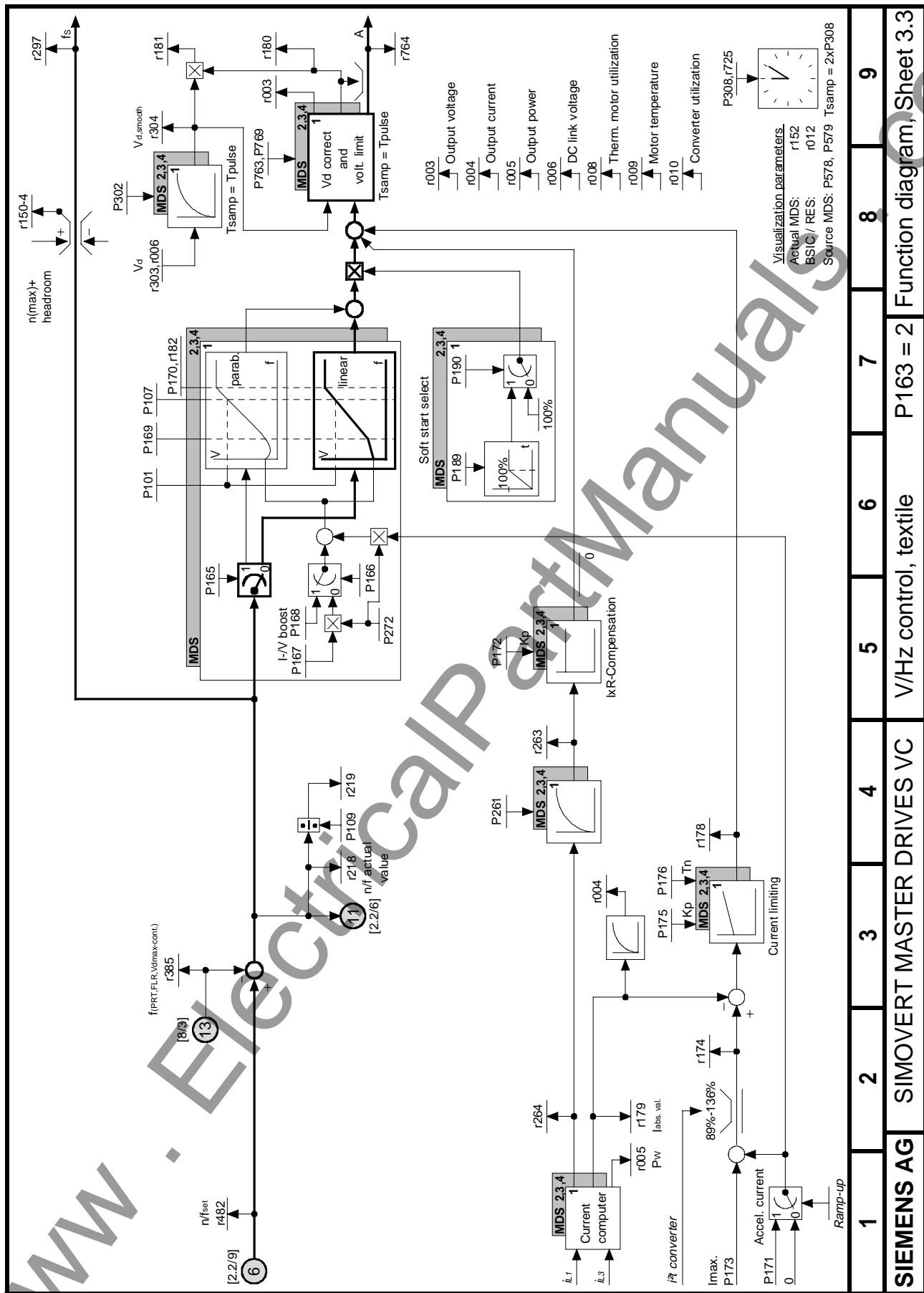

Fig. 10.8 V/Hz control textile (P163 = 2)

1	2	3	4	5	6	7	8	9	
SIEMENS AG			SIMOVERT MASTER DRIVES VC			V/Hz control, textile		P163 = 2	
Function diagram, Sheet 3.3									

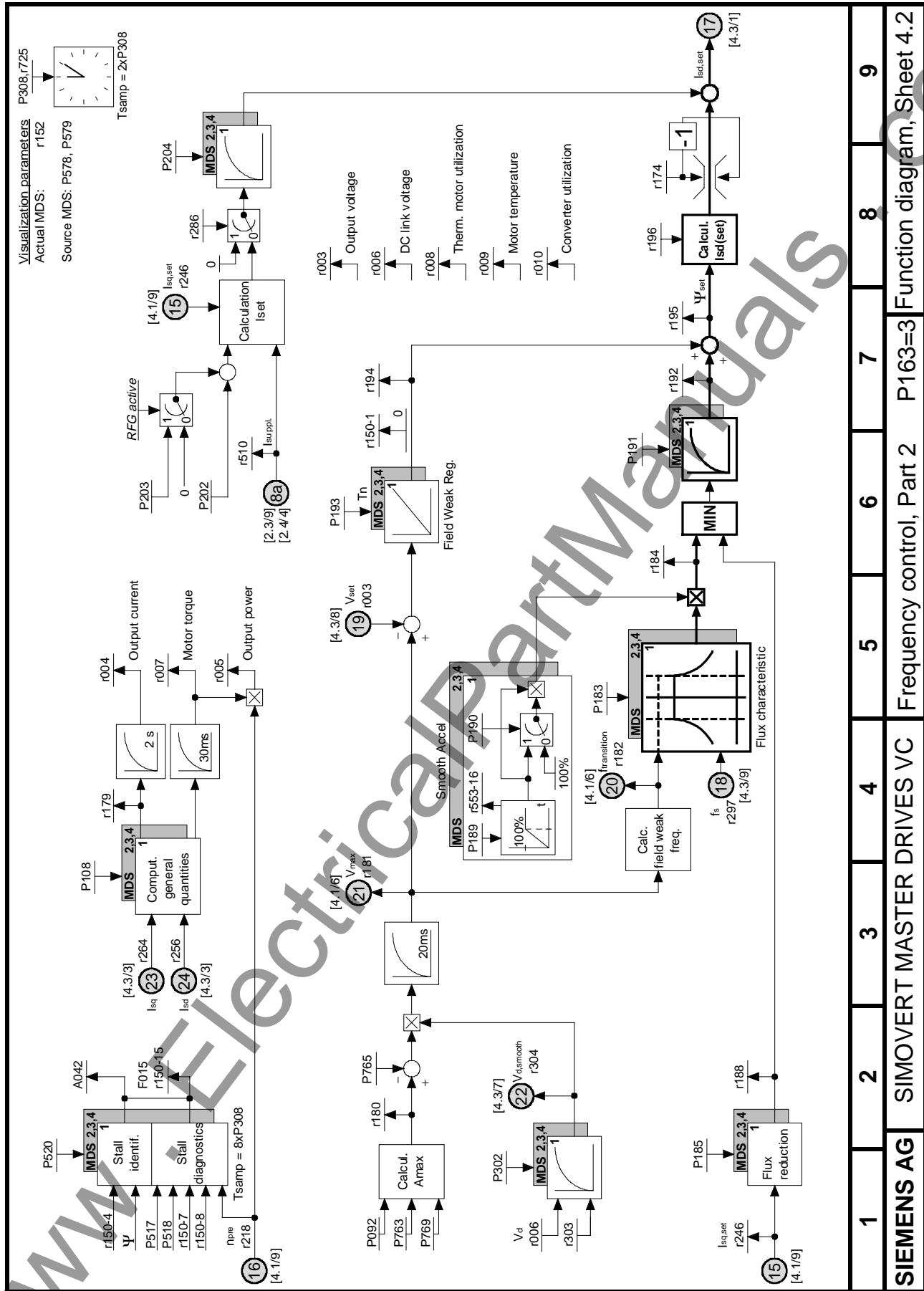

Fig. 10.10 Frequency control, Part 2 (P163 = 3)

1	2	3	4	5	6	7	8	9
SIEMENS AG SIMOVERT MASTER DRIVES VC				Frequency control, Part 2 P163=3			Function diagram, Sheet 4.2	

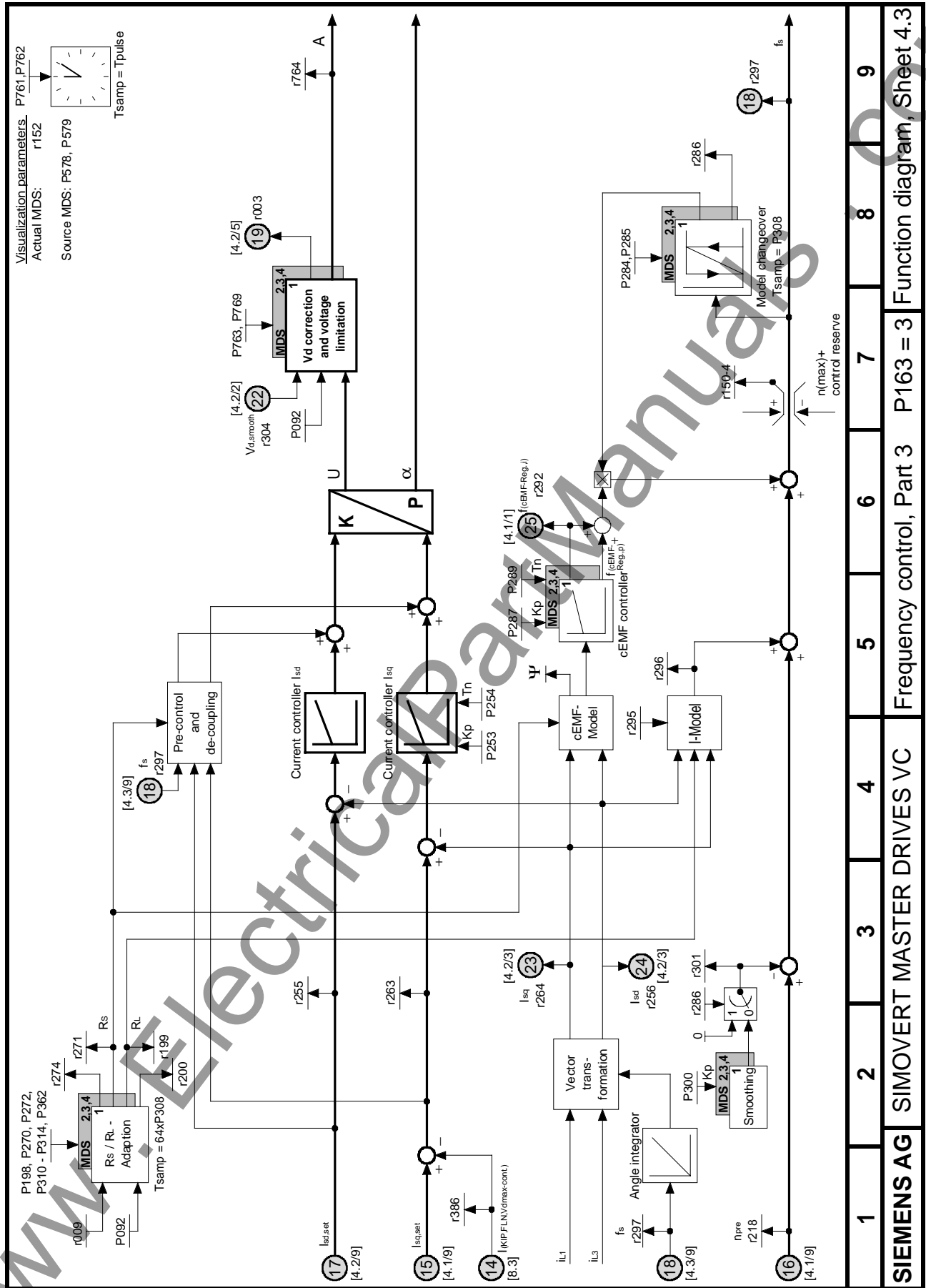

Fig. 10.11 Frequency control, Part 3 (P163 = 3)

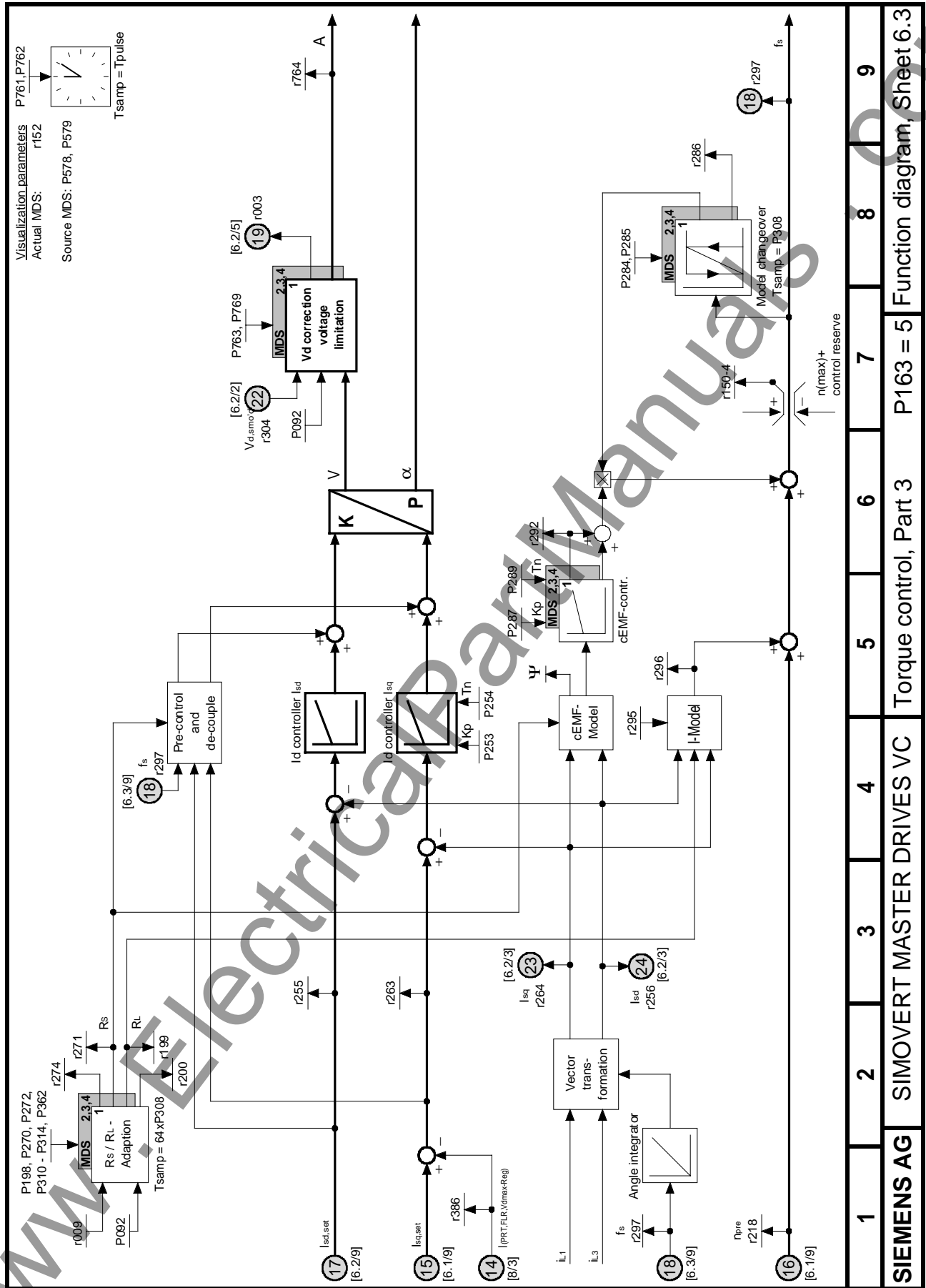

Fig. 10.17 Torque control, Part 3 (P163 = 5)

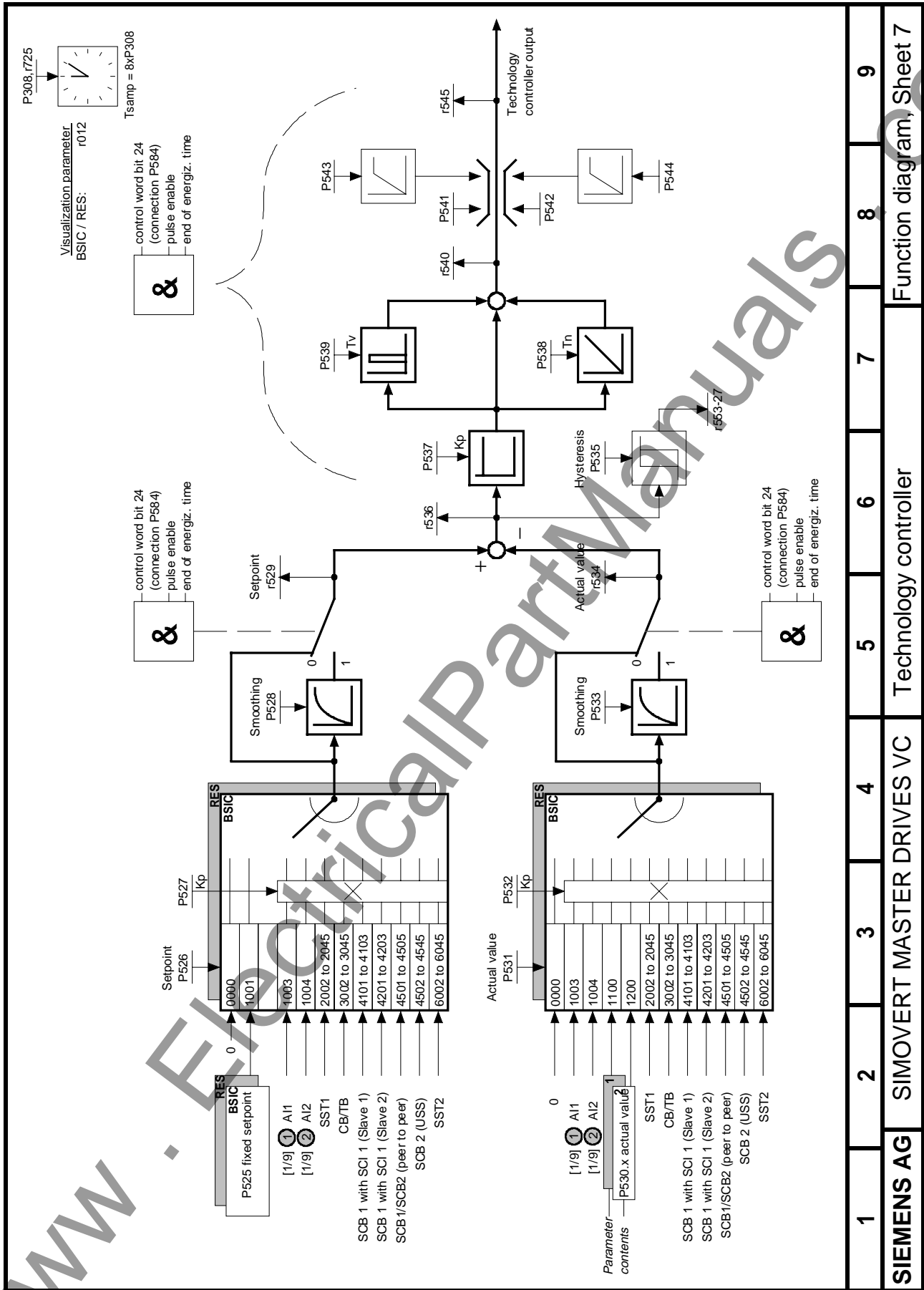

Fig. 10.18 Technology controller

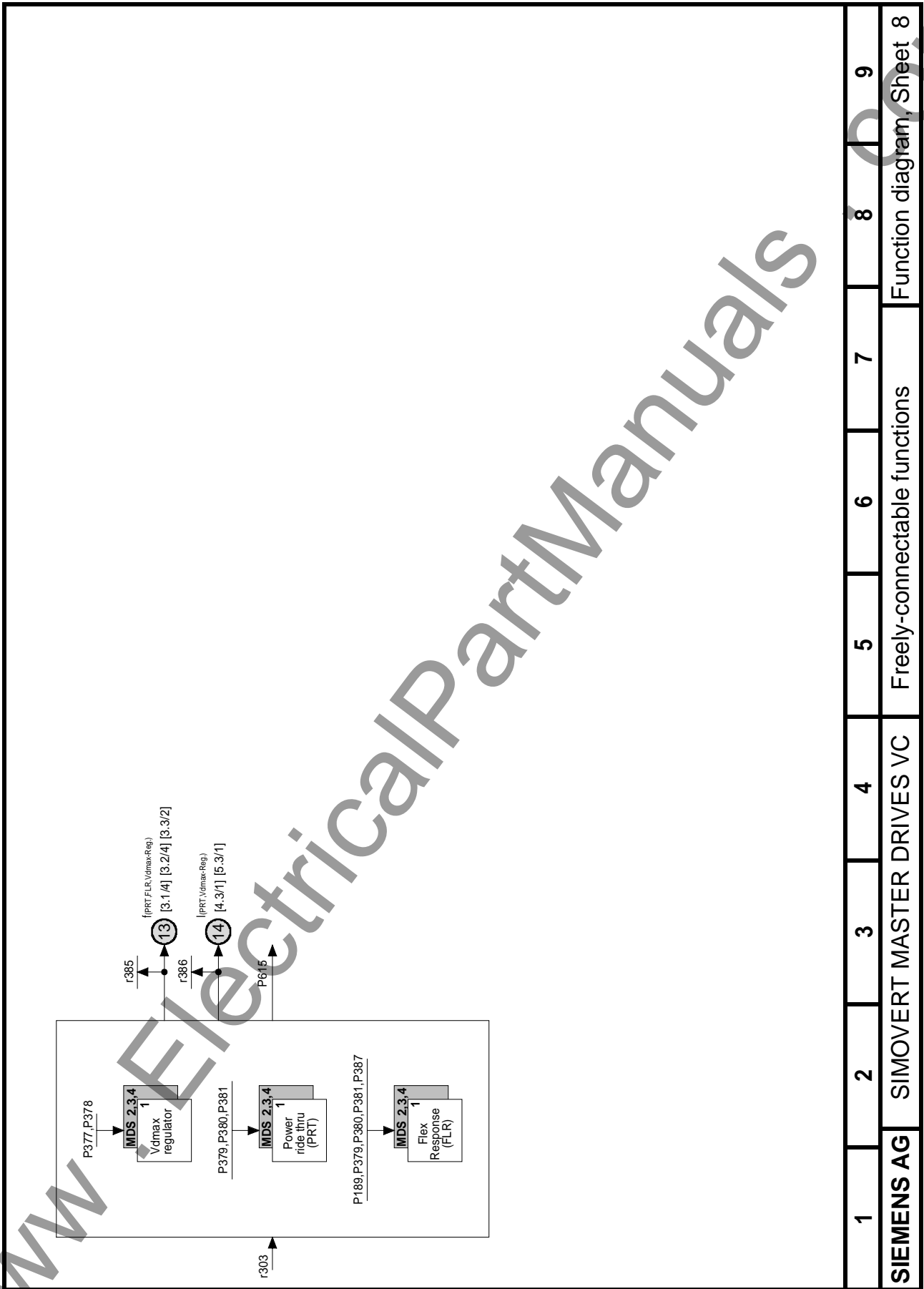

Fig. 10.19 Freely-connectable functions

www.ElectricalPartManuals.com

11 Parameter list

General Observation Parameters	up to 49	Analog Input/Output	from 650
General Parameters	from 50	Communications	from 680
Drive Data	from 70	Diagnosis	from 720
Hardware Configuration	from 89	Modulator	from 760
Motor Data	from 100	Factory Parameters	from 780
Control	from 150	Special Parameters	from 800
Functions	from 220	Profile Parameters	from 900
Setpoint Channel	from 410	Tech Board Parameters	from 1000
Control and Status Word	from 550		

Explanations on the Parameter List

Example:

PNU	Parameter Name in OP1	Range [Unit]	# of Indices	read: / write: /
*:conf-P	Description	Value texts	Factory Settings.	
P999 *1) 3E7Hex	Parameter Name in OP1 Description SDS(4)-Parameter ⁶⁾ Type=I2; ²⁾ PKW: 1Hex=0.01Hz; Process Data Group.: ³⁾	-300.00 to 300.00 [Hz]	2 i001=50.00 i002=50.00 or: ← ⁷⁾	²⁾⁵⁾ / BR ⁴⁾ ²⁾⁵⁾ / BR ⁴⁾

- 1) Confirmation Parameter: not active before pressing the -key
- 2) Parameter Type
 - O2 16 Bit Value without sign
 - I2 16 Bit Value with sign
 - I4 32 Bit Value with sign
 - L2 Nibble coded Quantity
 - V2 Bit coded Quantity
- 3) Normalization Group for Process Data (PcD)

Process Data Group	Process Data Normalization
0	as Parameter Value Normalization
1	4000Hex = P420 Rated System Frequency 4000_0000Hex = P420 f(n,anl) bei Ausgabe als PcD-Doppelwort
2	1000Hex = P102 Rated Motor Amps
3	1000Hex = P101 Rated Motor Volts
4	1000Hex = r307 Line Volts (AC)
5	4000Hex = P485 Rated system Torque
- 4) Drive status:
 - U MLFB Input
 - H Hardware Configuration
 - A Hardware Setting
 - B Ready (Including Fault)
 - R (Run) Operation (including Fly Restart, Power Ride Thru, Synchronising, Flexible Response)
- 5) Access Level which is minimum needed to display or change a Parameter
 - 1 Operation
 - 2 Standard Mode
 - 3 Expert Mode
- 6) Abbreviations for Index Parameters
 - SDS(4) Setpoint Channel Data Set Parameter with 4 Indices, to be changed via Control Word 2, Bits 16 and 17
 - MDS(4) Motor Data Set Parameter with 4 Indices, to be changed via Control Word 2, Bits 18 and 19
 - B/R Parameter which can be changed between Base and Reserve setting via Control Word 2, Bit 30
- 7) Parameter value is pre-assigned after initialization dependent on the MLFB drive converter.

11.1 General Observation Parameters

PNU *:conf-P	Parameter Name in OP1 Description	Range [Unit] Value texts	# of. Indices Factory Settings.	read: / write: /
r000	Operation Display Displays Drive Status, Fault Messages and Warnings; Description, refer to Section 6 operator control „Operator control“ in the Operating Instructions, Part 2.		-	1 /UHABR
r001 1Hex	Drive Status Displays the actual drive status Parameter Values: 0 = Drive MLFB input 1 = Drive initialization 2 = Hardware initialization 3 = Drive system initialization 4 = Hardware settings 5 = Drive system settings 6 = Selection on several drive test functions 7 = Fault 8 = Restart inhibition 9 = Ready for turn-ON 10 = Pre-charging of the DC link bus 11 = Ready for operation 12 = Ground fault test 13 = Flying Restart is active 14 = Drive is operating 15 = Ramp generator decelerating (OFF1) 16 = Quick Stop (OFF3) 17 = DC braking 18 = Motor data identification (standstill test) 19 = Speed controller optimization 20 = Synchronization active 21 = Download of parameter settings Analog Output: 100% Parameter Value=16384 Type=O2; PKW: 1HEX=1.0 PcD Gr.: 0	MLFB Input Drive Init H/W Init System Init H/W Setting System Set. Test Fault ON locked Rdy ON Precharging Rdy Operat. Grd Fit TST Fly Restart Operation OFF 1 OFF 2 DC Brake Mot ID Stop n Reg Opt. Synchronize Download	-	2 /UHABR
r003 3Hex	Output Volts Drive output voltage (Fundamental rms) Analog Output: 100% @ Parameter Value=4*P101 Type=O2; PKW: 1HEX=0.1V PcD Gr.: 3	[V]	-	2 / BR
r004 4Hex	Output Amps Drive output current (Fundamental rms) Analog Output: 100% @ Parameter Value=4*P102 Type=O2; PKW: 1HEX=0.1A PcD Gr.: 2	[A]	-	2 / BR
r005 5Hex	Output Power Output active power (calculated value) in % of rated motor power Analog Output: 100% @ Parameter Value=400.0% Type=l2; PKW: 1HEX=0.1% PcD: 4000HEX=400%	[%]	-	2 / BR
r006 6Hex	DC Bus Volts DC Bus voltage (actual value to be displayed on PMU and OP) Analog Output: 100% @ Parameter Value=4*r307 Type=l2; PKW: 1HEX=1.0V PcD Gr.: 4	[V]	-	2 / BR
r007 7Hex	Motor Torque Calculated torque in % of rated motor torque Condition: P163 = 3, 4, 5 (vector control types) Analog Output: 100% @ Parameter Value=400.0% Type=l2; PKW: 1HEX=0.1% PcD: 4000HEX=400%	[%]	-	2 / BR

PNU	Parameter Name in OP1	Range [Unit]	# of. Indices	read: write:
*:conf-P	Description	Value texts	Factory Settings.	/ /
r008 8Hex	<p>Motor Utilizat.</p> <p>Thermal motor utilization (calculated value)</p> <p>ATTENTION: for an overload protection of the motor which is derived from this parameter sufficient cooling of the motor must be guaranteed.</p> <p>Condition: P363 >= 100 s</p> <p>Analog Output: 100% @ Parameter Value=16384%</p> <p>Type=O2; PKW: 1HEX=1.0% PcD Gr.: 0</p>	[%]	-	2/ BR
r009 9Hex	<p>Motor Temperat.</p> <p>The motor temperature is measured via a temperature sensor inside the motor (KTY84).</p> <p>Condition: P360 > 0 or P361 > 1 The motor temperature can not be displayed if it is measured via a thermistor (P361 = 1). or P310 = 2 and P361 <> 1, temperature adaption with KTY sensor and no PTC thermistor evaluation</p> <p>Analog Output: 100 % @ Parameter Value=16384 °C</p> <p>Type=I2; PKW: 1HEX=1.0°C PcD Gr.: 0</p>	[°C]	-	2/ BR
r010 AHex	<p>Drive Utilizat.</p> <p>Drive utilization</p> <p>Thermal drive utilization as a result of an i^2t calculation of the output current.</p> <p>Maximum load of the drive will have the following reaction:</p> <ul style="list-style-type: none"> • after 30 sec. a warning message (P622) and • after 60 sec. a reduction of the output current to 91% of the rated drive current. <p>Analog Output: 100% @ Parameter Value=16384%</p> <p>Type=O2; PKW: 1HEX=1.0% PcD Gr.: 0</p>	[%]	-	2/ BR
r012 CHex	<p>Base / Reserve</p> <p>Base / reserve settings of the process data wiring for setpoint signals and for control word bits</p> <p>Parameter values:</p> <p>0: Base setting 1: Reserve setting</p> <p>Analog Output: 100% @ Parameter Value=16384</p> <p>Type=O2; PKW: 1HEX=1.0 PcD Gr.: 0</p>	Base Reserve	0 to 1	2/ BR
r013 DHex	<p>Operat. Hours</p> <p>Operation hours with released inverter pulses (drive status 'operation').</p> <p>Indices:</p> <p>i001 = Days: days (0...9999) i002 = Hour: hours (0...24) i003 = Sec: seconds (0...3600)</p> <p>Type=O2; PKW: 1HEX=1.0 PcD Gr.: 0</p>		3	2/ BR

11.2 General Parameters

PNU *:conf-P	Parameter Name in OP1 Description	Range [Unit] Value texts	# of. Indices Factory Settings.	read: / write: /
P050 * 32Hex	Language Display language on the optional operation panel OP and in the PC software SIMOVIS Parameter values: 0: Deutsch 1: English 2: Espanol 3: Francais 4: Italiano Type=O2; PKW: 1HEX=1.0 PcD Gr.: -	0 to 5 Deutsch English Espanol Francais Italiano	- 0	2 /UHABR 2 /UHABR
P051 * 33Hex	Access Level Setting of access levels; with higher access levels more parameters can be read and/or written. Parameter values: 1: Operating via PMU or OP with motor operated potentiometer function 2: Standard mode 3: Expert mode Type=O2; PKW: 1HEX=1.0 PcD Gr.: -	1 to 3 Operation Standard Expert	- 2	1 /UHABR 1 /UHABR

PNU	Parameter Name in OP1	Range [Unit]	# of. Indices	read: write:
*:conf-P	Description	Value texts	Factory Settings.	/ /
P052 * 34Hex	<p>Function Select</p> <p>Selection of several commissioning steps and special functions.</p> <p>Parameter values:</p> <p>0 = Return into the former drive status from one of the further described functions.</p> <p>1 = Parameter-Reset: all parameters are reset to their original settings (factory settings). According to the Profibus profile for variable speed drives this function is also accessible via parameter P970. After finishing this function the parameter is automatically reset to 0.</p> <p>2 = Release for MLFB setting (changing into the drive status 'Drive MLFB input'). To exit this function the parameter must be reset to 0.</p> <p>3 = Download/Upread (Changing into the drive status 'Download'). To exit this function the parameter must be reset to 0.</p> <p>4 = Hardware configuration (Changing into the drive status 'Hardware settings'). To exit this function the parameter must be reset to 0.</p> <p>5 = Drive system settings (Changing into the drive status 'Drive system settings' to parameterize the motor data). To exit this function without internal parameter adaptations, P052 must again be set to 0 (reset). If the motor data or pulse frequency were changed, the function should be exited with P052 = 6, 7 or 8.</p> <p>6 = Automatic parameterization: sets the control system parameters based on the motor name plate data and the gating unit configuration (e.g. P761, pulse frequency). Automatic parameter setting (parameterization) can only be called-up from the drive setting (P052 = 5).</p> <p>7 = Motor data identification at standstill: sets the control system parameters (except speed controller) based on measured motor data; this function contains ground fault test and function 6. (only for P100 = 0, 1 motor type = IEC, NEMA)</p> <p>8 = Complete motor data identification (includes functions 6, 7, 9, 10, 12); only for P163 = 3, 4, 5 (Vector control modes) Note: After alarm A078, the equipment must be powered-up, and measurement at standstill starts. At the end of measurement at standstill, alarm A080 appears, and the drive must be powered-up again. The no-load measurement then starts.</p> <p>9 = No load measurement; only for P163 = 3, 4, 5 (Vector control modes) (only for P100=0, 1 motor type = IEC, NEMA)</p> <p>10=Optimization of the n/f controller; only for P163 = 3, 4, 5 (Vector control modes)</p> <p>11=Self test; same as function 7, but without changing any parameter values (only for P100 = 0, 1 motor type = IEC, NEMA)</p> <p>12=Tachometer test; only for P163 = 3, 4, 5 (Vector control modes)</p> <p>Type=O2; PKW: 1HEX=1.0 PcD Gr.: -</p>	<p>0 to 12</p> <p>Return</p> <p>Par. Reset</p> <p>Set MLFB</p> <p>Download</p> <p>H/W Setting</p> <p>System Set.</p> <p>Auto Param.</p> <p>Mot ID Stop</p> <p>Mot ID All</p> <p>No Load Msr</p> <p>Reg. Optim.</p> <p>Auto Test</p> <p>Tach Test</p>	<p>-</p> <p>0</p>	<p>2 /UHABR</p> <p>2 /UHAB</p>

PNU *:conf-P	Parameter Name in OP1 Description	Range [Unit] Value texts	# of. Indices Factory Settings.	read: <input type="checkbox"/> write: <input type="checkbox"/>
P053 * 35Hex	Parameter Access Release of interfaces for the parameterization. At any time all interfaces have write access to this parameter. Parameter values: 0: none 1: COM BOARD (CB) 2: BASE KEYPAD (PMU) 4: BASE SERIAL (SST1) (SST1) 8: Serial I/O (SCB with USS) (SCB) 16: TECH BOARD (TB) 32: BASE SERIAL2 (SST2) (SST2) Description for Setting: <ul style="list-style-type: none"> • Every interface is coded by a number. • Input of the number or the total of several numbers which are related to interfaces, gives parameterization access to these interfaces. Example: The factory setting '6' means, that BASE KEYPAD (PMU) and BASE SERIAL (SST1) have parameterization access. Type=O2; PKW: 1HEX=1.0 PcD Gr.: -	0 to 63	- 6	1 / UHABR 1 / UHABR
P054 36Hex	OP Backlight Backlight for the optional operation panel OP Parameter values: 0 = Backlight always ON 1 = Backlight only ON during operation Type=O2; PKW: 1HEX=1.0 PcD Gr.: -	0 to 1 always ON dur.operat.	- 0	3 / BR 3 / BR

11.3 Drive Data

PNU	Parameter Name in OP1	Range [Unit]	# of. Indices	read: write:
*:conf-P	Description	Value texts	Factory Settings.	
P070 * 46Hex	MLFB (6SE70..) MLFB (model number) of the base drive Parameter values: see section „Initialization“ in the Operating Instructions, Part 2 Type=O2; PKW: 1HEX=1.0 PcD Gr.: -	0 to 151	- 0	3 / U BR 3 / U
P071 47Hex	Line Volts Line voltage of the drive Rated voltage of the feeding AC or DC mains; this parameter is used to calculate the rated DC bus voltage as a basis for the voltage limits of the Vd(max) and the Vd(min) [Power ride thru] controller (e. g. undervoltage failure limit). Type=O2; PKW: 1HEX=0.1V PcD Gr.: 0	90.0 to 1320.0 [V]	- ←	2 / ABR 2 / A
P072 48Hex	Rtd Drive Amps Rated drive output current Type=O2; PKW: 1HEX=0.1A PcD Gr.: 0	4.5 to 6540.0 [A]	- ←	2 / U ABR 4 / U
P073 49Hex	Rtd Drive Power Rated drive output power Type=O2; PKW: 1HEX=0.1kW PcD Gr.: 0	2.2 to 1800.0 [kW]	- ←	3 / U BR 4 / U
P077 * 4DHex	FactSettingType Selective factory setting. The parameter can be changed in the status „MLFB input“ (P052 = 2). If an MLFB still hasn't been entered, after the MLFB number has been entered and the „MLFB input“ has been left (P052=0) then the selected factory setting-type is immediately valid. A selective factory setting can be executed via „Par. reset“ (P052 = 1 or P970 = 0). This parameter value is not changed. Parameter values: 0: Factory setting as before. 1: With this setting, with respect to 0, the following parameters are initialized differently: P554, P568, P571, P572, P573, P574 2: With this setting, with respect to 0, the following parameters are initialized differently: P554, P558, P568, P571, P572, P573, P574, P575, P588, P602, P607 3: With this setting, with respect to 0, the following parameters are initialized differently: P554, P558, P565, P575, P588, P602, P607 Type=O2; PKW: 1 HEX=1.0 PcD Gr.: -	0 to 3 - Normal OP1 OP1 cabinet unit Cabinet terminal	- 0	3 / U BR 3 / U
r089 59Hex	Board Position 1 PCB in position #1 (left) of the electronic box Parameter Values: 0 = none 1 = SIMOVERT FC CU Board 2 = SIMOVERT VC CU Board 3 = SIMOVERT SC CU Board Type=O2; PKW: 1HEX=1.0 PcD Gr.: 0	0 to 3 none FC VC SC		3 / B

11.4 Hardware Configuration

PNU	Parameter Name in OP1	Range [Unit]	# of. Indices	read: / write: /																										
*:conf-P	Description	Value texts	Factory Settings.																											
P090 * 5AHex	<p>Board Position 2</p> <p>PCB in position #2 (right) of the electronic box</p> <p>Parameter values: 0 = no optional PCBs 1 = CB Communication Board 2 = TB Technology Board 3 = SCB Serial Communication Board 4 = TSY Digital-Tacho and Synchronization Board</p> <p>Description for Setting: Only the following combinations of PCBs and positions are admitted:</p> <table border="0"> <tr> <td>Position #3 (P091)</td> <td>Position #2 (P090)</td> </tr> <tr> <td>-</td> <td>CB</td> </tr> <tr> <td>-</td> <td>TB</td> </tr> <tr> <td>-</td> <td>SCB</td> </tr> <tr> <td>-</td> <td>TSY</td> </tr> <tr> <td>SCB</td> <td>CB</td> </tr> <tr> <td>CB</td> <td>TB</td> </tr> <tr> <td>SCB</td> <td>TB</td> </tr> <tr> <td>CB</td> <td>SCB</td> </tr> <tr> <td>CB</td> <td>TSY</td> </tr> <tr> <td>TSY</td> <td>CB</td> </tr> <tr> <td>SCB</td> <td>TSY</td> </tr> <tr> <td>TSY</td> <td>SCB</td> </tr> </table> <p>Type=O2; PKW: 1HEX=1.0 PcD Gr.: -</p>	Position #3 (P091)	Position #2 (P090)	-	CB	-	TB	-	SCB	-	TSY	SCB	CB	CB	TB	SCB	TB	CB	SCB	CB	TSY	TSY	CB	SCB	TSY	TSY	SCB	0 to 4 none CB TB SCB TSY	- 0	3 / H BR 3 / H
Position #3 (P091)	Position #2 (P090)																													
-	CB																													
-	TB																													
-	SCB																													
-	TSY																													
SCB	CB																													
CB	TB																													
SCB	TB																													
CB	SCB																													
CB	TSY																													
TSY	CB																													
SCB	TSY																													
TSY	SCB																													
P091 * 5BHex	<p>Board Position 3</p> <p>PCB in position #3 (center) of the electronic box</p> <p>Description see P090</p> <p>Type=O2; PKW: 1HEX=1.0 PcD Gr.: -</p>	0 to 4	- 0	3 / H BR 3 / H																										
P092 5CHex	<p>Output Filter</p> <p>Defines connected Output Filter</p> <p>Parameter values: 0 = no output filter 1 = sine wave output filter 2 = dV/dt filter</p> <p>Value '1' limits the depth of modulation to the range of space vector modulation (see also P763, maximum depth of modulation). After leaving drive settings (see P052 = 5) the pulse frequency (P761) is adapted to the sine wave filter requirements.</p> <p>Notes:</p> <ul style="list-style-type: none"> • For closed-loop speed/frequency/torque control and for temperature adaption (P310 > 0), the sinusoidal filter for the drive converter is taken into account. • Parameter value 2 limits the adjustable pulse frequency P761 to 3 kHz. <p>Type=O2; PKW: 1HEX=1.0 PcD Gr.: -</p>	0 to 2 none sine wave dV/dt	- 0	3 / ABR 3 / A																										

11.5 Motor Data

PNU	Parameter Name in OP1	Range [Unit]	# of. Indices	read: write:
*:conf-P	Description	Value texts	Factory Settings.	
P100 64Hex	<p>Type of Motor</p> <p>Changes between international (IEC) and US (NEMA) motor data parameterization modes. Input data are</p> <p>for IEC motors: power factor cos(PHI)</p> <p>for NEMA motors: efficiency and rated motor power</p> <p>Parameter values:</p> <p>0: IEC</p> <p>1: NEMA</p> <p>2: -</p> <p>3: Synchronous permanent magnet (only for special applications!)</p> <p>Note:</p> <p>The selection of a permanent-magnet synchronous motor (3) is only provided for specific special applications. In this case, the following functions are inhibited:</p> <p>Synchronizing (P582), restart-on-the-fly (P583, P369, P370), automatic restart (P366), DC brake (P372), motor identification (P052 = 7, 8, 9, 11), control type (P163 = 0, 2, 4, 5).</p> <p>MDS(4) Parameter</p> <p>Type=O2; PKW: 1HEX=1.0 PcD Gr.: -</p>	<p>0 to 3</p> <p>IEC</p> <p>NEMA</p> <p>Synchronous permanent</p>	<p>4</p> <p>i001=0</p> <p>i002=0</p> <p>i003=0</p> <p>i004=0</p>	<p>2 / ABR</p> <p>2 / A</p>
P101 * 65Hex	<p>Motor Rtd Volts</p> <p>Rated motor voltage</p> <p>Name plate value of the rated motor voltage; the valid kind of connection (star / delta) must be regarded.</p> <p>Input for Siemosyn motors is the rated voltage at rated motor frequency.</p> <p>Note:</p> <p>For P100 = 3 (motor type = sync. perm.), the motor rated voltage is only used as normalization quantity for the rated motor impedance (refer to P270), to which all resistances and reactances are referred (e.g. P120, P121, r199, r271, P272, P273)</p> <p>MDS(4) Parameter</p> <p>Type=O2; PKW: 1HEX=0.1V PcD Gr.: -</p>	<p>115.0 to 1600.0 [V]</p>	<p>4</p> <p>←</p>	<p>2 / ABR</p> <p>2 / A</p>
P102 66Hex	<p>Motor Rtd Amps</p> <p>Rated motor current; name plate value for the valid kind of connection (star / delta).</p> <p>MDS(4) Parameter</p> <p>Type=O2; PKW: 1HEX=0.1A PcD Gr.: 0</p>	<p>0.6 to 3000.0 [A]</p>	<p>4</p> <p>←</p>	<p>2 / ABR</p> <p>2 / A</p>
P103 * 67Hex	<p>Mot No Load Amps</p> <p>Motor no load current (rated magnetizing current, data sheet value) in % of rated motor Amps.</p> <p>A correct input improves the calculation of motor data and results in a more accurate active current calculation.</p> <p>Pre-set during motor data identification (P052 = 7, 8) and during the no load test (P052 = 9).</p> <p>Condition: P100 = 0, 1 (motor type = IEC, NEMA)</p> <p>Note: for 0 % < P103 < 10 % the value of P196 is set to 10 %.</p> <p>MDS(4) Parameter</p> <p>Type=O2; PKW: 1HEX=0.1% PcD: 4000HEX=400%</p>	<p>0.0 to 95.0 [%]</p>	<p>4</p> <p>i001=0.0</p> <p>i002=0.0</p> <p>i003=0.0</p> <p>i004=0.0</p>	<p>3 / ABR</p> <p>3 / AB</p>
P104 * 68Hex	<p>MotPwrFactor</p> <p>Power factor cos(PHI) of the motor (name plate value)</p> <p>Condition: P100 = 0 (IEC-Motor)</p> <p>MDS(4) Parameter</p> <p>Type=O2; PKW: 1HEX=0.001 PcD: 4000HEX=0.25</p>	<p>0.500 to 0.999</p>	<p>4</p> <p>←</p>	<p>2 / ABR</p> <p>2 / A</p>

PNU	Parameter Name in OP1	Range [Unit]	# of. Indices	read: <input type="checkbox"/> write: <input type="checkbox"/>
*:conf-P	Description	Value texts	Factory Settings.	
P105 * 69Hex	Motor Rtd Power Rated motor power (name plate value) Condition: P100 = 1 (NEMA-Motor) MDS(4) Parameter Type=O2; PKW: 1HEX=0.1hp PcD Gr.: 0	0.1 to 2000.0 [hp]	4 ←	2 / ABR 2 / A
P106 * 6AHex	Motor Rtd Effic. Rated motor efficiency (name plate value) Condition: P100 = 1 (NEMA-Motor) MDS(4) Parameter Type=O2; PKW: 1HEX=0.1% PcD: 4000HEX=25%	50.0 to 99.9 [%]	4 ←	2 / ABR 2 / A
P107 6BHex	Motor Rtd Freq Rated motor frequency Name plate value of the rated synchronous frequency of the motor. ATTENTION: Changing this parameter may also change the pulse frequency (P761). Notes: P163 = 0, 1: Maximum value is 200Hz P163 = 2: Maximum value is 600Hz P163 = 3, 4, 5: Maximum value is 200Hz The pole pair number (P109) is calculated when parameters are changed For induction motors, a slip (r295) must exist to P108 * P109/60, if the slip compensation function is to operate correctly. MDS(4) Parameter Type=O2; PKW: 1HEX=0.1Hz PcD: 4000HEX=163.84Hz	8.0 to 600.0 [Hz]	4 i001=50.0 i002=50.0 i003=50.0 i004=50.0	2 / ABR 2 / A
P108 * 6CHex	Motor Rtd Speed Rated motor speed (name plate value) Note: P163 = 0, 4, 5 (V/Hz control with speed control, speed/torque vector control) is only available with this information The pole pair number (P109) is calculated when parameters are changed For induction motors, a slip (r295) must exist to P107/ P109*60, if the slip compensation function is to correctly operate. MDS(4) Parameter Type=O2; PKW: 1HEX=1.0min-1 PcD Gr.: 0	0 to 36000 [min-1]	4 i001=0 i002=0 i003=0 i004=0	2 / ABR 2 / A
P109 * 6DHex	Motor #PolePairs Number of motor pole pairs (calculated from rated frequency (P107) and rated motor speed (P108)); may be checked and - if needed - corrected. Note: For applications with pulse encoder (P208=1, 2, 5, 6), a maximum pole pair number of P109 = 15 is possible. ATTENTION: As the pole pair number is automatically calculated when entering the rated motor frequency and speed (P107, P108), it is always necessary to check P109. P109 must be written into when downloading (P052 = 3). For machines with name plate data for regenerative operation the automatically calculated number of pole pairs must be increased by 1. MDS(4) Parameter Type=O2; PKW: 1HEX=1.0 PcD Gr.: -	1 to 99	4 ←	3 / ABR 3 / A
P110 6EHex	kT(n) Torque constant (kTn (100 Kelvin)) Torque/current ratio constant Condition: P100 = 3 (motor type = sync. perm.) MDS(4) parameter Type=O2; PKW: 1HEX=0.01Nm/APcD Gr.:0	0.00 to 4.99 [Nm/A]	4 i001=00.0 i002=00.0 i003=0.00 i004=0.00	3 / ABR 3 / A

PNU	Parameter Name in OP1	Range [Unit]	# of. Indices	read: write:
*:conf-P	Description	Value texts	Factory Settings.	
P120 78Hex	<p>X(magnet.d) tot. Motor magnetizing reactance (saturated) along the rotor axis (d axis), referred to the rated motor impedance).</p> <p>Automatic parameterization (P052 = 6) should be executed after the parameter value is changed.</p> <p>X(magnet,d) is added to X(sigma) (P273) to calculate the synchronous reactance in the d axis.</p> <p>Condition: P100 = 3 (motor type = sync. perm.) MDS(4) parameter Type=O2; PKW: 1HEX=0.1% PcD: 4000HEX=6400%</p>	1.0 to 999.0 [%]	4 i002=150.0 i002=150.0 i003=150.0 i004=150.0	3 / BR 3 / BR
P121 79Hex	<p>X(magnet.q) tot. Quadrature motor magnetizing reactance (saturated) (q axis), referred to the rated motor impedance.</p> <p>Automatic parameterization (P052 = 6) should be executed after the parameter value is changed).</p> <p>X(magnet,q) is added to X(sigma) (P273) to calculate the quadrature synchronous reactance (q axis).</p> <p>Condition: P100 = 3 (motor type = sync. perm.) MDS(4) parameter Type=O2; PKW: 1HEX=0.1% PcD: 4000HEX=6400%</p>	1.0 to 999.0 [%]	4 i002=150.0 i002=150.0 i003=150.0 i004=150.0	3 / BR 3 / BR

11.6 Control

PNU *:conf-P	Parameter Name in OP1 Description	Range [Unit] Value texts	# of. Indices Factory Settings.	read: / write: /																
r150 96Hex	<p>Control Status</p> <p>Status word of the control circuit</p> <p>Parameter values:</p> <p>Bit00 = 1: Ramp generator set command is active Bit01 = 1: Drive is operated in field weakening mode Bit02 = 1: Ud(min) controller is active (power ride thru) Bit03 = 1: Ud(max) controller is active Bit04 = 1: Frequency limitation is active Bit05 = 0: Ramp generator: acceleration lock is active Bit06 = 0: Ramp generator: deceleration lock is active Bit07 = 1: Speed controller output at upper limit Bit08 = 1: Speed controller output at lower limit Bit09 = 1: Ramp generator in protective mode Bit10 = 1: i(max) controller active Bit11 = 1: Initialization of the control circuit is finished Bit12 = 1: Speed controller: Output set command is active Bit13 = 1: Active current setpoint signal is at pull out limit Bit14 = 1: Counter-EMF controller is at the limit Bit15 = 1: Motor pulled out or blocked</p> <p>Coding of bits on the PMU display:</p> <table style="margin-left: auto; margin-right: auto; border-collapse: collapse;"> <tr> <td style="border: 1px solid black; padding: 2px;">15</td><td style="border: 1px solid black; padding: 2px;">14</td> <td style="border: 1px solid black; padding: 2px;">13</td><td style="border: 1px solid black; padding: 2px;">12</td> <td style="border: 1px solid black; padding: 2px;">11</td><td style="border: 1px solid black; padding: 2px;">10</td> <td style="border: 1px solid black; padding: 2px;">9</td><td style="border: 1px solid black; padding: 2px;">8</td> </tr> <tr> <td style="border: 1px solid black; padding: 2px;">7</td><td style="border: 1px solid black; padding: 2px;">6</td> <td style="border: 1px solid black; padding: 2px;">5</td><td style="border: 1px solid black; padding: 2px;">4</td> <td style="border: 1px solid black; padding: 2px;">3</td><td style="border: 1px solid black; padding: 2px;">2</td> <td style="border: 1px solid black; padding: 2px;">1</td><td style="border: 1px solid black; padding: 2px;">0</td> </tr> </table> <p>Type=V2; PKW: 1HEX=1.0 PcD Gr.: 0</p>	15	14	13	12	11	10	9	8	7	6	5	4	3	2	1	0		-	3 / BR
15	14	13	12	11	10	9	8													
7	6	5	4	3	2	1	0													
r152 98Hex	<p>act. MotDataSet</p> <p>Displays the active motor data set</p> <p>Parameter values:</p> <table style="margin-left: 20px;"> <tr><td>0:</td><td>motor data set 1</td></tr> <tr><td>1:</td><td>motor data set 2</td></tr> <tr><td>2:</td><td>motor data set 3</td></tr> <tr><td>3:</td><td>motor data set 4</td></tr> </table> <p>Type=O2; PKW: 1HEX=1.0 PcD Gr.: 0</p>	0:	motor data set 1	1:	motor data set 2	2:	motor data set 3	3:	motor data set 4	MotDataSet1 MotDataSet2 MotDataSet3 MotDataSet4	-	3 / ABR								
0:	motor data set 1																			
1:	motor data set 2																			
2:	motor data set 3																			
3:	motor data set 4																			
P158 9EHex	<p>S. Initial angle</p> <p>Source of the initial angle</p> <p>The rotor angle (r159) and the position angle (r160) are only set to the new initial angle if the initial angle changes. If a 16-bit value is connected, only r159 and the least significant word of r160 are changed. The most significant word of r160 (number of revolutions) then remains unchanged. r160 and r159 are completely changed when a 32-bit value is entered. If the initial angle remains the same, then r159 and r160 are not set.</p> <p>Parameter values:</p> <table style="margin-left: 20px;"> <tr><td>0000:</td><td></td></tr> <tr><td>1001:</td><td></td></tr> <tr><td>1003:</td><td>Analog input 1</td></tr> <tr><td>1004:</td><td>Analog input 2</td></tr> </table> <p>Additional values: In accordance with the PcD connection of the setpoint channel</p> <p>Condition: P208 = 5, 6 (rotary encoder with zero pulse)</p> <p>B/R parameter</p> <p>Type=L2; PKW:PKW format (HEX)=Par Value PcD Gr.:0</p>	0000:		1001:		1003:	Analog input 1	1004:	Analog input 2	0 to 6045	2 i001=0000 i002=0000	3 / BR 3 / BR								
0000:																				
1001:																				
1003:	Analog input 1																			
1004:	Analog input 2																			
r159 9FHex	<p>Rotor angle</p> <p>Rotor angle which is sensed via an encoder (P208).</p> <p>Condition: P208 = 5, 6 (rotary encoder with zero pulse)</p> <p>Angle notation: 0000=0°, 8000 Hex = 180°, FFFF Hex = 359.995°</p> <p>Analog output: 100% @ Parameter Value = 16384</p> <p>Type=O2; PKW: 1HEX=1.0 PcD Gr.:0</p>		- -	2 / BR																

PNU	Parameter Name in OP1	Range [Unit]	# of. Indices	read: write:
*:conf-P	Description	Value texts	Factory Settings.	/ /
r160 A0Hex	Position angle Position actual value over several rotor revolutions (r159). Condition: P208 = 5, 6 (rotary encoder with zero pulse) Angle notation: 0000 = 0°, 8000 Hex = 180°, FFF Hex = 359.995° Analog output: 100% @ Parameter Value = 16384 Type= I4; PKW: 1HEX=1.0 PcD Gr.:0		- -	2 / BR
P163 A3Hex	Control Mode Attention: Changing this parameter may also change the pulse frequency (P761). Parameter values: 0: V/Hz control with superposed speed control (only for P100 = 0, 1 IEC, NEMA) 1: V/Hz control 2: V/Hz control for textile applications; allows no frequency corrections e. g. by the current limitation controller (only for P100 = 0, 1 IEC, NEMA) 3: Frequency control (without tachometer) 4: Speed control (only for P100 = 0, 1 IEC, NEMA) 5: Torque control (only for P100 = 0, 1 IEC, NEMA) MDS(4) Parameter Type=O2; PKW: 1HEX=1.0 PcD Gr.: -	0 to 5 V/Hz+ nReg V/Hz V/Hz Textil f Regulat. n Regulat. T Regulat.	4 i001=1 i002=1 i003=1 i004=1	3 / ABR 3 / A
P165 A5Hex	V/Hz Mode V/Hz mode Parameter values: 0: linear characteristic (for constant torque drives) 1: parabolic characteristic (for pumps, fans, etc.) See section „V/Hz mode“ in the Operating Instructions, Part 2 Condition: P163 = 0, 1, 2 (V/Hz mode) MDS(4) Parameter Type=O2; PKW: 1HEX=1.0 PcD Gr.: -	0 to 1 linear parabolic	4 i001=0 i002=0 i003=0 i004=0	2 / ABR 2 / A
P166 A6Hex	Boost Mode Boost mode at f = 0 Hz Parameter values: 0: Current boost: a voltage boost is calculated by means of a starting current (P167) allowing for the measured stator resistance. 1: Voltage boost: the voltage boost of the V/Hz curve is directly entered via P168. See section „V/Hz mode“ in the Operating Instructions, Part 2 Condition: P163 = 0, 1, 2 (V/Hz modes) MDS(4) Parameter Type=O2; PKW: 1HEX=1.0 PcD Gr.: -	0 to 1 Curr.Boost Volt.Boost	4 i001=1 i002=1 i003=1 i004=1	2 / BR 2 / B
P167 A7Hex	Boost Amps Current boost in % of rated motor current is the basis for the voltage boost at f = 0 Hz, allowing for the measured stator resistance. See section „V/Hz mode“ in the Operating Instructions, Part 2 Condition: P163 = 0, 1, 2 (V/Hz modes) P166 = 0 (Current boost) MDS(4) Parameter Type=O2; PKW: 1HEX=0.1% PcD: 4000HEX=400%	10.0 to 400.0 [%]	4 i001=100.0 i002=100.0 i003=100.0 i004=100.0	2 / BR 2 / BR

PNU	Parameter Name in OP1	Range [Unit]	# of. Indices	read: <input type="checkbox"/> write: <input type="checkbox"/>
*:conf-P	Description	Value texts	Factory Settings.	
P168 A8Hex	Boost Volts Voltage boost at f = 0 in % of rated motor voltage (P101) The value is pre-assigned for automatic parameter setting (P052 = 6, 7) See section „V/Hz mode“ in the Operating Instructions, Part 2 Condition: P163 = 0, 1, 2 (V/Hz modes) P166 = 1 (Voltage boost) MDS(4) Parameter Type=O2; PKW: 1HEX=0.01% PcD: 4000HEX=400%	0.00 to 25.00 [%]	4 i001=2.00 i002=2.00 i003=2.00 i004=2.00	2 / BR 2 / BR
P169 A9Hex	Boost End Freq End frequency of voltage boost In the range from 0 Hz to the end frequency the voltage boost is reduced to 0. Special case: A value of 0 Hz causes the output voltage to stay constant until crossing the normal V/Hz curve ('horizontal boost'). The value is pre-set during automatic parameterization (P052 = 6) and during motor data identification (P052 = 7, 8). See section „V/Hz mode“ in the Operating Instructions, Part 2 Condition: P163 = 0, 1, 2 (V/Hz modes) MDS(4) Parameter Type=O2; PKW: 1HEX=0.1Hz PcD Gr.: 1	0.0 to 300.0 [Hz]	4 i001=10.0 i002=10.0 i003=10.0 i004=10.0	2 / BR 2 / BR
P170 AAHex	Field Weak Freq Start frequency for field weakening At higher frequencies the output voltage is kept constant. If the voltage limit is reached below this value, field weakening starts at a lower frequency. See section „V/Hz mode“ in the Operating Instructions, Part 2 Note: r182 (real frequency at start of field weakening) The maximum value is limited to 2 * P107 (rated motor frequency). Condition: P163 = 0, 1, 2 (V/Hz modes) MDS(4) Parameter Type=O2; PKW: 1HEX=0.1Hz PcD Gr.: 1	8.0 to 600.0 [Hz]	4 i001=50.0 i002=50.0 i003=50.0 i004=50.0	2 / BR 2 / B
P171 ABHex	Accel Amps Additional acceleration current in % of rated motor current Additional current setpoint signal for high acceleration torque at low speed. The acceleration current is only active during acceleration and up to the end frequency (P169) of the voltage boost. It may be used to generate a break off torque. See section „V/Hz mode“ in the Operating Instructions, Part 2 Condition: P163 = 0, 1, 2 (V/Hz modes) MDS(4) Parameter Type=O2; PKW: 1HEX=0.1% PcD: 4000HEX=400%	0.0 to 799.9 [%]	4 i001=0.0 i002=0.0 i003=0.0 i004=0.0	3 / BR 3 / BR
P172 ACHex	IxR Compens Gain Compensation of voltage drops on long motor cables in % of the rated motor impedance. Depending on the actual torque generating current component the output voltage is increased . See section „V/Hz mode“ in the Operating Instructions, Part 2 Condition: P163 = 0, 1, 2 (V/Hz modes) MDS(4) Parameter Type=O2; PKW: 1HEX=0.01% PcD: 4000HEX=25%	0.00 to 40.00 [%]	4 i001=0.00 i002=0.00 i003=0.00 i004=0.00	2 / BR 2 / BR

PNU	Parameter Name in OP1	Range [Unit]	# of. Indices	read: write:
*:conf-P	Description	Value texts	Factory Settings.	/ /
P173 ADHex	<p>Imax Maximum current (Fundamental rms)</p> <p>Setpoint signal for the current limit (Imax controller @ V/Hz modes and current controller @ vector control modes) to protect the motor and the drive, respectively.</p> <p>Setting range: 0.125 to 4,00*rated motor current (P102), but maximum 1.36 or 1.6 * rated drive current (P072).</p> <p>Refer to the Section „Setting the short-time overload capability“ in the Operating Instructions, Part 2. The secondary conditions for P173 > 136% are specified there.</p> <p>After automatic parameterization (P052 = 6) and motor data identification (P052 = 7, 8) the parameter is pre-set to 1,5 * rated motor current (P102). Reaction (derating) may result from the pulse frequency parameter (P761).</p> <p>Related display parameter: r174: realized maximum current setpoint signal; allows for other influences</p> <p>MDS(4) Parameter Type=O2; PKW: 1HEX=0.1A PcD Gr.: 2</p>	0.1 to 6535.5 [A]	4 ←	2 / BR 2 / BR
r174 AEHex	<p>Imax(set) Maximum current (realized setpoint signal for current limitation); allows for the influences of the I²t calculation and the acceleration current (P171)</p> <p>V/Hz modes (P163 = 0, 1, 2): realized setpoint signal for the Imax controller</p> <p>Vector control modes (P163 = 3, 4, 5): realized limitation for the current controllers</p> <p>Dependent Parameter: P173 (maximum current, parameterized value)</p> <p>MDS(4) Parameter Analog Output: 100% @ Parameter Value=4*P102 Type=O2; PKW: 1HEX=0.1A PcD Gr.: 2</p>	[A]	-	3 / BR
P175 AFHex	<p>Imax Reg. Gain Gain of the current limiting PI controller (Imax controller).</p> <p>The parameter is pre-set during automatic parameterization (P052 = 6) and during motor data identification (P52 = 7, 8).</p> <p>Condition: P163 = 0, 1, 2 (V/Hz modes)</p> <p>MDS(4) Parameter Type=O2; PKW: 1HEX=0.001 PcD: 4000HEX=0.25</p>	0.005 to 0.499	4 i001=0.050 i002=0.050 i003=0.050 i004=0.050	3 / BR 3 / BR
P176 B0Hex	<p>Imax Reg. Time Integral time constant of the current limiting PI controller (Imax controller).</p> <p>Condition: P163 = 0, 1, 2 (V/Hz modes)</p> <p>MDS(4) Parameter Type=O2; PKW: 1HEX=1.0ms PcD Gr.: 0</p>	4 to 32001 [ms]	4 i001=100 i002=100 i003=100 i004=100	3 / BR 3 / BR
r177 B1Hex	<p>f(Imax-Reg.) Frequency output of the Imax controller.</p> <p>The sign depends of the sign of the torque generating current component.</p> <p>Note: P163 = 0, 1 (V/Hz modes except textile applications)</p> <p>Analog Output: 100 % @ Parameter Value=163.84Hz Type=l2; PKW: 1HEX=0.1Hz PcD: 4000HEX=163.84Hz</p>	[Hz]	-	3 / BR

PNU	Parameter Name in OP1	Range [Unit]	# of. Indices	read: <input type="checkbox"/> write: <input type="checkbox"/>
*:conf-P	Description	Value texts	Factory Settings.	
r178 B2Hex	V(lmax-Reg.) Output voltage of the lmax controller to reduce the drive setpoint voltage. Notes: P163 = 0, 1 (V/Hz modes except textile applications): Only active, when the stator frequency setpoint signal is less than the rated slip frequency (r295). P163 = 2 (Textile applications): Active in the complete frequency range but no frequency correction (r177). Analog Output: 100% @ Parameter Value=4*P101 Type=l2; PKW: 1HEX=0.1V PcD Gr.: 3	[V]	-	3 / BR
r179 B3Hex	Output Amps(rms) Output current (fundamental rms); fast actual value for automation purposes. Analog Output: 100% @ Parameter Value=4*P102 Type=O2; PKW: 1HEX=0.1A PcD Gr.: 2	[A]	-	3 / BR
r180 B4Hex	Mod Depth Limit The modulation depth limit is mainly influenced by the modulator, it is always equal or less than the value of P763 (e. g. when a sine wave filter is present (P091 = 1) or when edge modulation is off (P769 > 0)) Note: The maximum possible control limit (approx. 93 %) of the gating unit at frequencies less than 28 Hz, is only taken into account in r181. Analog Output: 100% @ Parameter Value=400% Type=O2; PKW: 1HEX=0.1% PcD: 4000HEX=400%	[%]	-	3 / BR
r181 B5Hex	Max Output Volts Maximum possible output voltage; calculated of the maximum depth of modulation (r180) and the actual value of the DC bus voltage (r304). Note: P163 = 3, 4, 5 (Vector control modes): The headroom in the depth of modulation (P765) is allowed for at vector control modes. Analog Output: 100% @ Parameter Value=4*P101 Type=O2; PKW: 1HEX=0.1V PcD Gr.: 3	[V]	-	3 / BR
r182 B6Hex	FieldWeakFrq-act Frequency at start of field weakening; compared to P170 the available voltage headroom is allowed for. P163 = 0, 1, 2 (V/Hz modes): In combination with the actual value of the frequency this parameter is used to calculate a field weakening curve for the adaptation of the slip in the field weakening range. P163 = 3, 4, 5 (vector control modes): In vector control modes the flux is kept constant up to this frequency, at higher frequencies it is reduced. Analog Output: 100% @ Parameter Value=P420 Type=O2; PKW: 1HEX=0.01Hz PcD Gr.: 1	[Hz]	-	3 / BR
P183 B7Hex	Flux(Set) Flux setpoint signal Psi(set) in % of rated rotor flux of the motor. At values below 100% the motor is operated undermagnetized, at higher values it is overmagnetized. Condition: P163 = 3, 4, 5 (Vector control modes) P100 = 0, 1 (motor type = IEC, NEMA) MDS(4) Parameter Type=O2; PKW: 1HEX=0.1% PcD: 4000HEX=400%	50.0 to 200.0 [%]	4 i001=100.0 i002=100.0 i003=100.0 i004=100.0	3 / BR 3 / BR

PNU	Parameter Name in OP1	Range [Unit]	# of. Indices	read: write:
*:conf-P	Description	Value texts	Factory Settings.	/ /
r184 B8Hex	Flux(Curve) Flux setpoint signal at the output of the flux curve in % of rated rotor flux of the motor Condition: P163 = 3, 4, 5 (Vector control modes) P100 = 0, 1 (motor type = IEC, NEMA) Analog Output: 100% @ Parameter Value=400.0% Type=O2; PKW: 1HEX=0.1% PcD: 4000HEX=400%	[%]	-	3/ BR
P185 B9Hex	Min.Loaddepend.Flux Reference value for the rotor flux under no-load conditions for load-adaptive magnetization (lower rotor flux limit). The reference flux increases when loaded, so that the magnetization current corresponds to the torque-generating current (r246). The load-adaptive magnetization in the partial load range restricts the drive dynamic performance. Parameter values: 100.0%: no load-adaptive magnetization <100.0%: load adaptive magnetization activated Setting instructions: <ul style="list-style-type: none"> In this efficiency optimizing mode, the flux reference value (P183) may not exceed approx. 110%. The smoothing time constant of the flux setpoint (P191) must be selected to be that much higher the lower the load-dependent rotor flux is set (min. 100 ms for speed control and 500 ms for frequency control). Condition: P163 = 3, 4, 5 (vector control types) P100 = 0, 1 (motor type = IEC, NEMA) MDS(4) Parameter Type=O2; PKW: 1HEX=0.1% PcD: 4000HEX=400%	50.0 to 100.0 [%]	4 i001=100.0 i002=100.0 i003=100.0 i004=100.0	3/ BR 3/ B
r188 BCHex	Flux(LoadDepend) Flux setpoint signal of the load adaptive flux curve in % of the rated rotor flux of the motor. Condition: P163 = 3, 4, 5 (Vector control modes) P185 < 100 (load adaptive flux reduction on) P100 = 0, 1 (motor type = IEC, NEMA) Analog Output: 100% @ Parameter Value=400.0% Type=O2; PKW: 1HEX=0.1% PcD: 4000HEX=400%	[%]	-	3/ BR

PNU *:conf-P	Parameter Name in OP1 Description	Range [Unit] Value texts	# of. Indices Factory Settings.	read: / write: /
<p>P189 BDHex</p>	<p>Excitation Time Motor excitation time Wait time between pulse release and ramp generator release. Within this period the magnetization of the induction motor is built up. The value is pre-set during automatic parameterization (P052 = 6) and during motor data identification (P052 = 7, 8). Notes: P163 = 0, 1, 2 (V/Hz modes): The magnetization is built up at a frequency of 0 Hz with the selected V/Hz curve voltage (see P167 and P168, respectively) If smooth acceleration mode (P190 = 1) is selected, the voltage increases ramp-like instead of step-like. P163 = 3, 4, 5 (vector control types): The magnetization is ramped-up. If smooth acceleration mode (P190 = 1) is selected, the flux increases in a parabolic way. P100 = 3 (sync. perm): The drive can align itself before the no-encoder open-loop control or control accelerates within the excitation time (also refer to P467) Note: The „restart-on-the-fly active“ status bit (refer to P616) is set during the motor excitation time. MDS(4) Parameter Type=O2; PKW: 1HEX=0.01s PcD Gr.: 0</p>	<p>0.01 to 10.00 [s]</p>	<p>4 i001=1.00 i002=1.00 i003=1.00 i004=1.00</p>	<p>3 / BR 3 / BR</p>
<p>P190 BEHex</p>	<p>Smooth Accel For smooth starting, the flux in the motor is established with some delay. This is to ensure, that even with residual magnetization, the motor only rotates in the required direction of rotation. P163 = 0, 1, 2 (V/Hz modes): If smooth acceleration mode is selected, at turn on the output voltage increases ramp like to the V/Hz curve voltage within the excitation time (P189). P163 = 3, 4, 5 (Vector control modes) If smooth acceleration mode is selected, at turn on the flux setpoint signal (P183) increases in a parabolic way within the excitation time. Parameter values: 0 = off 1 = on MDS(4) Parameter Type=O2; PKW: 1HEX=1.0 PcD Gr.: -</p>	<p>0 to 10 to 1 0: off 1: on</p>	<p>4 i001=0 i002=0 i003=0 i004=0</p>	<p>3 / BR 3 / BR</p>
<p>P191 BFHex</p>	<p>Smooth Flux(Set) Smoothing time constant (PT1) of the flux setpoint signal Psi(set). The parameter is pre-set during automatic parameterization (P052 = 6) and during motor data identification (P052 = 7, 8). Description for Setting: Low values cause excellent dynamic response, high values cause excellent smooth running behavior in the field-weakening range and for load-dependent flux reduction < 50 ms: for high dynamic response requirements > 50 ms: for lower dynamic response requirements > 100 ms: for load adaptive flux reduction with speed control (P185) > 500 ms: for load adaptive flux reduction with frequency control (P185) Condition: P163 = 3, 4, 5 (vector control types) P100=0, 1 (motor type = IEC, NEMA) MDS(4) Parameter Type=O2; PKW: 1HEX=1.0ms PcD Gr.: 0</p>	<p>4 to 2000 [ms]</p>	<p>4 i001=15 i002=15 i003=15 i004=15</p>	<p>3 / BR 3 / BR</p>

PNU	Parameter Name in OP1	Range [Unit]	# of. Indices	read: write:
*:conf-P	Description	Value texts	Factory Settings.	/ /
r192 C0Hex	Flux(Set,smooth) Smoothed flux setpoint signal at the output of the flux setpoint filter in % of rated rotor flux of the motor. Dependent parameters: P191 (Smoothing of the flux setpoint signal) P190 (Smooth acceleration mode) P189 (Excitation time) Condition: P163 = 3, 4, 5 (Vector control modes) P100 = 0, 1 (motor type = IEC, NEMA) Analog Output: 100% @ Parameter Value=400.0% Type=O2; PKW: 1HEX=0.1% PcD Gr.: 0	[%]	-	3/ BR
P193 C1Hex	FieldWeakRegTime Integral time constant of the field weakening / Vmax controller. Related display parameters: r150 (Status word of the control system) r194 (Output signal of the field weakening controller) r195 (Flux setpoint signal of the vector control) Condition: P163 = 3, 4, 5 (Vector control modes) MDS(4) Parameter Type=O2; PKW: 1HEX=1.0ms PcD Gr.: 0	10 to 32001 [ms]	4 i001=150 i002=150 i003=150 i004=150	3/ BR 3/ BR
r194 C2Hex	Flux(FieldWkReg) Output signal of the field weakening controller in % of rated rotor flux of the motor. Flux reduction as output signal of the field weakening controller. When the maximum drive output voltage (r181) is reached, the controller reduces the smoothed flux setpoint signal of the field weakening curve (r192). Condition: P163 = 3, 4, 5 (Vector control modes) P100 = 0, 1 (motor type = IEC, NEMA) Analog Output: 100% @ Parameter Value=400.0% Type=I2; PKW: 1HEX=0.1% PcD: 4000HEX=400%	[%]	-	3/ BR
r195 C3Hex	Flux(Set,Total) Resulting flux setpoint signal of the vector control in % of rated rotor flux of the motor. Condition: P163 = 3, 4, 5 (Vector control modes) P100 = 0, 1 (motor type = IEC, NEMA) Analog Output: 100% @ Parameter Value=400.0% Type=O2; PKW: 1HEX=0.1% PcD: 4000HEX=400 %	[%]	-	3/ BR
r196 C4Hex	No Load Amps Rated magnetizing current (see P103, motor no load current) if P103 = 0.0%: r196 is automatically calculated if 0.0% < P103 < 10.0%: r196 = 0.1 * P102 (rated motor current) if P103 >= 10%: r196 = P103 * P102 Condition: P100 = 0, 1 (motor type = IEC, NEMA) Analog Output: 100% @ Parameter Value=4*P102 Type=O2; PKW: 1HEX=0.1A PcD Gr.: 2	[A]	-	3/ BR

PNU	Parameter Name in OP1	Range [Unit]	# of Indices	read: / write: /
*:conf-P	Description	Value texts	Factory Settings.	
P198 C6Hex	<p>RotResistTmpFact</p> <p>Correction factor to allow for the influence of the rotor temperature on the rotor resistance.</p> <p>Pre-set data automatic parameterization (P052 = 6) and during motor data identification (P052 = 7, 8).</p> <p>Description for setting:</p> <p>Motor under full load (motor warm): 100.0%</p> <p>Motor under partial load (motor cool): 50% - 70%</p> <p>Condition: P163 = 3, 4, 5 (Vector control modes) P310 = 0 (Temperature adaption inactive) P100 = 0, 1 (motor type = IEC, NEMA)</p> <p>MDS(4) Parameter Type=O2; PKW: 1HEX=0.1% PcD 4000HEX=400%</p>	12.5 to 400.0 [%]	4 i001=80.0 i002=80.0 i003=80.0 i004=80.0	3 / BR 3 / BR
r199 C7Hex	<p>RotResist</p> <p>Rotor resistance of the motor in % of the rated motor impedance.</p> <p>If a KTY 84 temperature sensor is connected this parameter follows the motor temperature.</p> <p>Condition: P163 = 3, 4, 5 (Vector control modes) P100 = 0, 1 (motor type = IEC, NEMA)</p> <p>Analog Output: 100% @ Parameter Value = 25.00%</p> <p>Type=O2; PKW: 1HEX=0.01% PcD: 4000HEX=25%</p>	[%]	-	3 / BR
r200 C8Hex	<p>Rotor Time Const</p> <p>Rotor time constant of the motor (calculated) or induction motors, the d- and q-axis values are always identical.</p> <p>Indices: i001 = d axis i002 = q axis</p> <p>Condition: P100 = 0, 1 (motor type = IEC, NEMA)</p> <p>Analog output: 100% @ Parameter Value = 16384 ms</p> <p>Type=O2; PKW: 1HEX=1.0ms PcD Gr.: 0</p>	[ms] -d -q	2	3 / BR
P202 CAHex	<p>Torque (static)</p> <p>Maximum required steady state torque in % of rated motor torque</p> <p>At frequency control (P163 = 3) and non-active counter EMF model (r286 = 0, low frequencies) a constant current is impressed to the motor. The parameter represents the maximum required torque during constant frequency setpoint. For safety reasons the parameter should allow for at least 10 % more than the expected torque.</p> <p>Parameter values:</p> <p>0 %: constant current is the rated magnetizing current 100 %: constant current is the rated motor current.</p> <p>Setting instructions:</p> <p>During acceleration the transition to the counter EMF model (r286 = 1) is significantly influenced by the protective mode of the ramp generator (P467).</p> <p>A minimum value of approx. 20 % must be used for permanent-magnet synchronous motors (P100 = 3); this allows the drive to align itself when the drive converter is powered-up (refer to P189).</p> <p>Condition: P163 = 3 (Frequency control)</p> <p>MDS(4) Parameter Type=O2; PKW: 1HEX=0.1% PcD: 4000HEX=400%</p>	0.0 to 200.0 [%]	4 i001=80.0 i002=80.0 i003=80.0 i004=80.0	3 / BR 3 / BR

PNU	Parameter Name in OP1	Range [Unit]	# of. Indices	read: write:
*:conf-P	Description	Value texts	Factory Settings.	
P203 CBHex	<p>Torque (dynamic)</p> <p>Maximum additional dynamic torque in % of rated motor torque</p> <p>At acceleration and deceleration additionally to the current for the steady state torque (P202) another current is impressed to improve starting behavior.</p> <p>The total current during acceleration is calculated from the settings of P202 and P203, during steady state operation only from P202.</p> <p>Description for setting:</p> <p>For the only purpose of an acceleration torque the speed controller forward control (P243) can also be used.</p> <p>Condition: P163 = 3 (Frequency control)</p> <p>MDS(4) Parameter</p> <p>Type=O2; PKW: 1HEX=0.1% PcD: 4000HEX=400%</p>	0.0 to 200.0 [%]	4 i001=0.0 i002=0.0 i003=0.0 i004=0.0	3 / BR 3 / BR
P204 CCHex	<p>Smooth I(Set)</p> <p>Smoothing of the current setpoint signal</p> <p>Time constant for smoothing the setpoint signals of the current components described in P202 and P203 .</p> <p>Condition: P163 = 3 (Frequency control)</p> <p>MDS(4) Parameter</p> <p>Type=O2; PKW: 1HEX=1.0ms PcD Gr.: 0</p>	4 to 32000 [ms]	4 i001=40 i002=40 i003=40 i004=40	3 / BR 3 / BR
P208 * D0Hex	<p>Src RotSpeed act</p> <p>Type of tachometer and type of its connection (for speed or torque control (P163=0, 4, 5) a tachometer must be reported).</p> <p>Parameter values:</p> <p>0 = no tachometer 1 = Encoder 2 = Encoder with control track 3 = Analog tachometer via analog input #1 4 = Analog tachometer via analog input #2 5 = Pulse encoder with zero pulse 6 = Pulse encoder with zero pulse and check track</p> <p>Notes</p> <p>P208 = 1, 2, 5, 6 (encoder):</p> <ul style="list-style-type: none"> Only encoders with a phase shift of 90° between the 2 tracks can be used. At setting '2' or '6' a low level signal or disconnecting of the control track terminal of the TSY board will cause the fault message F052 in order to report a broken wire. Set P209 to the number of pulses of the encoder. <p>Please refer to the manual of your encoder or to the TSY manual for details.</p> <p>P208 = 3, 4 (Analog tachometer)</p> <ul style="list-style-type: none"> Scale the analog tachometer input via P210 If the output voltage of the analog tachometer may be > 10 V, the analog tachometer interface (ATI) must be used. <p>Related display parameter:</p> <p>r214 (Actual speed measured by the tachometer)</p> <p>Conditions: P163 = 0 (V/Hz mode with speed control) P163 = 4, 5 (speed or torque control) with analog tachometer: ATI board if needed</p> <p>MDS(4) Parameter</p> <p>Type=O2; PKW: 1HEX=1.0 PcD Gr.: -</p>	0 to 4 none Encoder Enc+CtTrack AnalogTach1 AnalogTach2 Pulse width zero Pulse zero check	4 i001=0 i002=0 i003=0 i004=0	3 / ABR 3 / A

PNU	Parameter Name in OP1	Range [Unit]	# of. Indices	read: <input type="checkbox"/> write: <input type="checkbox"/>
*:conf-P	Description	Value texts	Factory Settings.	
P209 D1Hex	<p>Encoder Pulse #</p> <p>Number of pulses of the encoder</p> <p>Description for setting:</p> <ul style="list-style-type: none"> Parameter is only needed if an encoder is used (P208 = 1 or 2). The factor, pulse number * motor frequency (P107) should not exceed 400000, as otherwise the speed computation will be inaccurate <p>Related display parameter: r214 (Actual speed measured by the tachometer)</p> <p>Condition: P208 = 1, 2, 5, 6 (pulse encoder)</p> <p>MDS(4) Parameter Type=O2; PKW: 1HEX=1.0 PcD Gr.: 0</p>	60 to 20000	4 i001=1024 i002=1024 i003=1024 i004=1024	3 / ABR 3 / A
P210 D2Hex	<p>AnalogTachScale</p> <p>Analog tachometer scaling</p> <p>Speed which causes 10 V input signal at the analog input (see P208).</p> <p>The gain setting board ATI is required to connect the analog tachometer to the drive if the tachometer voltage may exceed 10 V.</p> <p>ATTENTION: The parameter value is at same time the limit of the speed measurement range. Speed overshoots must be allowed for. Analog tachometers can be used up to drive output frequencies of max. 100 Hz.</p> <p>Description for Setting:</p> <p>Example: Maximum speed is 3000 rpm plus a 10 % overshoot, an ATI board is used</p> <ol style="list-style-type: none"> P210 must be set to 3300 rpm (3000 rpm + 10 %), in V/Hz mode (P163 = 1) the motor must be operated at 3300 rpm (e. g. to be measured with an external rpm meter) <p>ATTENTION: The analog input where the ATI board is connected to must not be parameterized to be a setpoint input!</p> <ol style="list-style-type: none"> the output voltage of the ATI board, connected to the selected analog input terminal (P208) must be adjusted to 10.00 V. <p>Note: if an analog tachometer is selected (P208 = 3, 4) the parameter is pre-set during motor data identification (P052 = 8, 9).</p> <p>Dependent parameter: The offset of the analog input must be adjusted (P652).</p> <p>Condition: P208 = 3, 4 (analog tachometer)</p> <p>MDS(4) Parameter Type=O2; PKW: 1HEX=1.0min-1 PcD Gr.: 0</p>	500 to 6000 [RPM]	4 i001=3000 i002=3000 i003=3000 i004=3000	3 / ABR 3 / ABR
r214 D6Hex	<p>Meas'd Rot.Speed</p> <p>Actual speed value, measured via a tachometer (P208).</p> <p>Analog Output: 100% @ Parameter Value=P420</p> <p>Type=l4; PKW: 1HEX=0.001Hz PcD Gr.: 1</p>	[Hz]	-	3 / BR
P215 D7Hex	<p>max. dn/dt</p> <p>Maximum allowed change of the measured speed actual value in % of rated motor speed (P108) during one sampling period of the control system (P308).</p> <p>The function may identify noise or interrupted speed signals e. g. caused by defective cable shielding or tachometer coupling.</p> <p>ATTENTION: This function limits the rate of change in speed of the drive. If a warning message is reported during acceleration or at load changes it may be needed to increase the parameter value.</p> <p>Pre-set during automatic parameterization (P052 = 6, 7, 8) .</p> <p>Related display parameter: r218 (Actual speed value)</p> <p>Condition: P208 <> 0 (Source of actual speed value)</p> <p>MDS(4) Parameter Type=O2; PKW: 1HEX=0.1% PcD: 4000HEX=400%</p>	0.1 to 199.9 [%]	4 i001=10.0 i002=10.0 i003=10.0 i004=10.0	3 / BR 3 / BR

PNU	Parameter Name in OP1	Range [Unit]	# of. Indices	read: write:
*:conf-P	Description	Value texts	Factory Settings.	/ /
P216 D8Hex	<p>Slip fail corr'n</p> <p>Smoothing time constant of the n/f actual value forward control Related display parameter: r218 (n/f actual value) @ speed control r220 (n/f-actual value) @ frequency control</p> <p>The value is pre-assigned during automatic parameter setting (P052 = 6), or with the motor identification run (P052 = 7, 8). Condition: P163 = 3, 4, 5 (vector control types) MDS(4) Parameter Type=O2; PKW: 1HEX=0.1ms PcD Gr.: -</p>	0.0 to 20.0 [ms]	4 i001=0.0 i002=0.0 i003=0.0 i004=0.0	3 / BR 3 / BR
P217 D9Hex	<p>Slip fail corr'n</p> <p>slip failure correction for the n/f actual value. The delay correction is only active at speed control with encoder (P208 = 1, 2); it improves the torque accuracy during acceleration. Parameter values: 0 = off 1 = correction with a time constant of about 32 ms 2 = correction with a time constant of about 16 ms Related display parameter: r218 (n/f actual value) Condition: P163 = 4, 5 (speed or torque control) MDS(4) Parameter Type=O2; PKW: 1HEX=1.0 PcD Gr.: -</p>	0 to 2 none slow normal	4 i001=0 i002=0 i003=0 i004=0	3 / BR 3 / BR
r218 DAHex	<p>n/f(act)</p> <p>Actual value of speed / frequency P163 = 0, 3, 4, 5 (V/Hz modes with speed control, Vector control modes): actual speed multiplied with the number of pole pairs of the motor (P109) P163 = 1, 2 (V/Hz mode, V/Hz mode for textile applications) @ slip compensation P294 = 0 %: stator frequency P163 = 1 (V/Hz mode) and slip compensation (P294) active: actual speed multiplied with the number of pole pairs of the motor (P109) Analog Output: 100% @ Parameter Value=P420 Type=l4; PKW: 1HEX=0.001Hz PcD Gr.: 1</p>	[Hz]	-	3 / BR
r219 DBHex	<p>n(act)</p> <p>Actual speed P163 = 0, 3, 4, 5 (V/Hz modes with speed control, Vector control modes): actual speed of the motor P163 = 1, 2 (V/Hz mode, V/Hz mode for textile applications) @ slip compensation P294 = 0 %: stator frequency divided by the number of pole pairs of the motor (P109) P163 = 1 (V/Hz mode) and slip compensation (P294) active: actual speed Analog Output: 100% @ Parameter Value=P420 Type=l4; PKW: 1HEX=0.001Hz PcD Gr.: 1</p>	[Hz]	-	2 / BR
r220 DCHex	<p>n/f(FWD Ctrl)</p> <p>n/f actual value (of the forward control) The value is calculated from the synthetic actual speed value and the smoothed proportional part of the counter-EMF controller; it is used as input signal for the n/f actual value smoothing function (P221). Condition: P163 = 3 (Frequency control) Analog Output: 100% @ Parameter Value=P420 Type=l4; PKW: 1HEX=0.001Hz PcD Gr.: 1</p>	[Hz]	-	3 / BR

PNU	Parameter Name in OP1	Range [Unit]	# of. Indices	read: / write: /
*:conf-P	Description	Value texts	Factory Settings.	
P221 DDHex	Smooth n/f(act) Smoothing time constant of the actual n/f value for the speed controller (Application, e. g. if the gear box has play). Pre-set during automatic parameter setting (P052 = 6) and during motor data identification (P052 = 7, 8, 10). Related display parameter: r222 (smoothed n/f actual value) Condition: P163 = 0, 3, 4, 5 (V/Hz mode with speed control, Vector control modes) MDS(4) Parameter Type=O2; PKW: 1HEX=1.0ms PcD Gr.: 0	0 to 2000 [ms]	4 i001=0 i002=0 i003=0 i004=0	2 / BR 2 / BR
r222 DEHex	n/f(act,smo'd) Smoothed n/f actual value at the input of the speed controller Dependent parameter: P221 (Smoothing of the n/f actual value) Condition: P163 = 0, 3, 4, 5 (V/Hz mode with speed control, Vector control modes) Analog Output: 100% @ Parameter Value=P420 Type=I4; PKW: 1HEX=0.001Hz PcD Gr.: 1	[Hz]	-	2 / BR
r223 DFHex	n/f(set,Reg-IN) n/f setpoint signal of the speed controller input At active n/f controller forward control (P243 <> 0) the n/f setpoint signal of the setpoint channel (r482) is filtered with a time constant according to P221. Analog Output: 100% @ Parameter Value=P420 Type=I4; PKW: 1HEX=0.001Hz PcD Gr.: 1	[Hz]	-	2 / BR
r224 E0Hex	n/f Deviation Control deviation at the input of the speed controller. Condition: P163 = 0, 3, 4, 5 (U/f mode with speed control, Vector control modes) Analog Output: 100% @ Parameter Value=P420 Type=I4; PKW: 1HEX=0.001Hz PcD Gr.: 1	[Hz]	-	3 / BR
P225 E1Hex	n/f Reg. Gain Proportional gain of the n/f controller; internally pre-set value according to source wiring (P226 = 1001). Pre-set during automatic parameterization (P052 = 6, 7) and during n/f controller optimization (P052 = 8, 10). Related display parameter: r228 (actual n/f controller proportional gain) Condition: P163 = 0, 3, 4, 5 (V/Hz mode with speed control, Vector control modes) MDS(4) Parameter Type=O2; PKW: 1HEX=0.01 PcD: 4000HEX=64	0.00 to 250.00	4 i001=10.00 i002=10.00 i003=10.00 i004=10.00	2 / BR 2 / BR
P226 * E2Hex	Src n/f RegAdapt Source of the adaptation of the proportional gain of the n/f controller (P225) Parameter values: 0000: Gain = 0 (n/f controller locked) 1001: Gain as set in P225 1003: Analog input 1 (smoothed adaptation) 1004: Analog input 2 (smoothed adaptation) other values: according to process data wiring of the setpoint channel. Condition: P163 = 3, 4, 5 (Vector control modes) B/R Parameter Type=L2; PKW: PKW-Format(HEX)=Par Value PcD Gr.: 0	0 to 6045	2 i001=1001 i002=1001	3 / BR 3 / BR

PNU *:conf-P	Parameter Name in OP1 Description	Range [Unit] Value texts	# of. Indices Factory Settings.	read: write:
P227 E3Hex	n/f RegAdaptGain Proportional gain of the adaptation of the n/f controller if set via analog input or via serial communications (P226). Description for setting: The effective gain (r228) is limited to a value of 30. for analog inputs: $P228 \text{ (effective gain)} = P225 * \frac{P227}{100.00 \%} * \frac{\text{input signal}}{1 \text{ V}}$ for serial communications input: $P228 \text{ (effective gain)} = P225 * \frac{P227}{100.00 \%} * \frac{\text{input signal} * 10}{4000\text{h}}$ Example: P227 = 100%, input signal at analog input : 1 V -> effective gain of the n/f controller (P228): 1 * P225 B/R Parameter Type=l2; PKW: 1HEX=0.01% PcD Gr.: 0	-300.00 to 300.00 [%]	2 i001=100.00 i002=100.00	3 / BR 3 / BR
r228 E4Hex	n/f RegGain(act) Effective gain of the n/f controller - see formula at P227 Condition: P163 = 0, 3, 4, 5 (V/Hz modes with speed control, Vector control modes) Analog Output: 100% @ Parameter Value=64.00 Type=O2; PKW: 1HEX=0.01 PcD: 4000HEX=64		-	3 / BR
P229 E5Hex	n/f Reg Time Integral time constant of the speed controller pre-set during automatic parameterization (P052 = 6, 7) and during n/f controller optimization (P052 = 8, 10). Description for setting: With a value of 32001 ms the integral part of the controller is turned off, the controller operates as a P controller. Related display parameter: r237 (integral part of the n/f controller) Condition: P163 = 0, 3, 4, 5 (V/Hz mode with speed control, vector control modes) MDS(4) Parameter Type=O2; PKW: 1HEX=1.0ms PcD Gr.: 0	25 to 32001 [ms]	4 i001=400 i002=400 i003=400 i004=400	2 / BR 2 / BR
P231 E7Hex	Kp Isq(max) Correction factor to calculate the maximum torque-generating current components in the field-weakening range (r234 Isqmax). Setting instructions: If the value is set too high, the induction motor can de-magnetize when loaded in the field-weakening range (motor stalls). Condition: P163 = 3, 4, 5 (vector control types) MDS(4) Parameter Type=O2; PKW: 1HEX=0.1% PcD 4000HEX=400%	25.0 to 400.0 [%]	4 i001=100.0 i002=100.0 i003=100.0 i004=100.0	3 / BR 3 / BR
P233 E9Hex	Max Regen Power Maximum allowed regenerative active power in % of the rated drive power Description for setting: In drives without braking chopper or regenerative front end the parameter should be set to about -10 % in order to support the Vdmax controller. The torque limit should not be used to limit the drive power. Related display parameters: r235 (maximum torque limit) r236 (minimum torque limit) Condition: P163 = 3, 4, 5 (Vector control modes) MDS(4) Parameter Type=l2; PKW: 1HEX=0.1% PcD: 4000HEX=400%	-300.0 to -0.1 [%]	4 i001=-300.0 i002=-300.0 i003=-300.0 i004=-300.0	3 / BR 3 / BR

PNU	Parameter Name in OP1	Range [Unit]	# of. Indices	read: / write: /
*:conf-P	Description	Value texts	Factory Settings.	
r234 EAHex	Isqmax Maximum amount of the torque generating current component Dependent parameters: P231 (Kp Isq(max)), r174 (Imax), r181 (Vmax), r255 (Isd(set)) Condition: P163 = 3, 4, 5 (Vector control modes) Analog Output: 100% @ Parameter Value=4*P102 Type=l2; PKW: 1HEX=0.1A PcD Gr.: 2	[A]	-	3 / BR
r235 EBHex	Pos Max Torque Maximum allowed torque (calculated from torque limitation (r497), regenerative active power limit (P233) and maximum current limit (r234)) in % of rated motor torque. At torque control parameter r497 is the limited positive torque setpoint in the setpoint channel. The lower torque limit (r236) may not exceed this upper torque limit. Condition: P163 = 3, 4, 5 (Vector control modes) Analog Output: 100% @ Parameter Value=P485 Type=l2; PKW: 1HEX=0.1% PcD Gr.: 5	[%]	-	2 / BR
r236 ECHex	Neg Max Torque Minimum allowed torque (calculated from torque limitation (r503), regenerative active power limit (P233) and maximum current limit (r234)) in % of rated motor torque. At torque control parameter r503 is the limited negative torque setpoint in the setpoint channel. The upper torque limit (r235) cannot fall below this torque limit. Condition: P163 = 3, 4, 5 (Vector control modes) Analog Output: 100% @ Parameter Value=P485 Type=l2; PKW: 1HEX=0.1% PcD Gr.: 5	[%]	-	2 / BR
r237 EDHex	I-Output f Reg Integral part of the n/f controller output signal (torque setpoint) in % of the rated motor torque Condition: P163 = 0, 3, 4, 5 (V/Hz mode with speed controller, Vector - 3, 4, 5 control modes) Analog Output: 100% @ Parameter Value=P485 Type=l2; PKW: 1HEX=0.1% PcD Gr.: 5	[%]	-	3 / BR
r238 EEHex	I-Output n/f Reg Output signals of the n/f controller (torque reference value/setpoint) before torque limiting, referred to the rated motor torque. Condition: P163 = 3, 4, 5 (Vector control types) Analog output: 100% @ Parameter Value = P485 Typ = l2; PKW: 1HEX=0.1% PcD Gr.:5	[%]	-	3 / BR
P242 F2Hex	Start-up Time Start-up time of the drive system from stand-still to rated motor speed at acceleration with rated motor torque. The parameter value corresponds to the moment of inertia (normalized) and is allowed for the calculation of the n/f controller forward control (P243). Pre-assignment for automatic parameterization (P052 = 6, 7) with P242 = 1.00 s or for n/f reg. optimization (P052 = 8, 10) with the measured value. Condition: P163=3,4,5 (Vector control modes) MDS(4) Parameter Type=O2; PKW: 1HEX=0.01s PcD Gr.: 0	0.10 to 327.67 [s]	4 i001=1.00 i002=1.00 i003=1.00 i004=1.00	3 / BR 3 / BR

PNU	Parameter Name in OP1	Range [Unit]	# of. Indices	read: write:
*:conf-P	Description	Value texts	Factory Settings.	/ /
P243 F3Hex	<p>n/f RegFWD Gain</p> <p>Proportional gain of the n/f controller forward control.</p> <p>Based on the changes of the speed setpoint (r478) the acceleration torque is calculated allowing for the inertia (see P242). Acceleration because of the additional setpoint signal 2 in the setpoint channel is not regarded.</p> <p>Pre-assignment for automatic parameterization (P052 = 6, 7) with P243 = 0.0 % or for n/f reg. optimization (P052 = 8, 10) with P243 = 100.0 %.</p> <p>Description for Setting:</p> <p>0.0%: Forward control off</p> <p>100.0%: forward control of the n/f controller with the rated torque used for P242.</p> <p>Condition: P163 = 3, 4 (n/f control)</p> <p>MDS(4) Parameter</p> <p>Type=O2; PKW: 1HEX=0.1% PcD: 4000HEX=400%</p>	0.0 to 200.0 [%]	4 i001=0.0 i002=0.0 i003=0.0 i004=0.0	3 / BR 3 / BR
r244 F4Hex	<p>Torque(set,add)</p> <p>Additional torque (added at the output of the n/f controller) in % of rated motor torque</p> <p>Only at n/T control the additional torque results of the acceleration forward control (P243) and the additional torque of the setpoint channel (r510). (for frequency control, only if P508 = 1).</p> <p>Condition: P163 = 3, 4 (Vector control modes)</p> <p>Analog Output: 100% @ Parameter Value=P485</p> <p>Type=I2; PKW: 1HEX=0.1% PcD Gr.: 5</p>	[%]	-	3 / BR
r245 F5Hex	<p>Torque(set,tot)</p> <p>Limited torque setpoint signal at the output of the speed controller in % of rated motor torque (includes the additional torque (r244)).</p> <p>Condition: P163 = 3, 4, 5 (Vector control modes)</p> <p>Analog Output: 100% @ Parameter Value=P485</p> <p>Type=I2; PKW: 1HEX=0.1% PcD Gr.: 5</p>	[%]	-	2 / BR
r246 F6Hex	<p>Isq(set)</p> <p>Setpoint signal for the torque generating flux signal</p> <p>Condition: P163 = 3, 4, 5 (Vector control modes)</p> <p>Analog Output: 100% @ Parameter Value=4*P102</p> <p>Type=I2; PKW: 1HEX=0.1A PcD Gr.: 2</p>	[A]	-	3 / BR
P247 F7Hex	<p>Droop</p> <p>Selection of the torque quantity for the droop feedback.</p> <p>Parameter values:</p> <p>0: Feedback of the integral part of the n/f controller (r237)</p> <p>1: Feedback of the limited torque setpoint signal (r245)</p> <p>2: Feedback of the n/f controller output signal without additional torque (r238)</p> <p>3: Feedback of the integral part of the n/f controller incl. the additional torque</p> <p>4: Feedback of the n/f controller output signal incl. additional torque</p> <p>Dependent parameter: P584 = Source of droop release</p> <p>Condition: P163 = 3, 4 (n/f control)</p> <p>MDS(4) Parameter</p> <p>Type=O2; PKW: 1HEX=1.0 PcD Gr.: -</p>	0 to 4	4 i001=0 i002=0 i003=0 i004=0	3 / BR 3 / BR

PNU	Parameter Name in OP1	Range [Unit]	# of Indices	read: / write: /
*:conf-P	Description	Value texts	Factory Settings.	
P248 F8Hex	<p>Droopgain</p> <p>Gain of the droop feedback</p> <p>Gain of the controller output signal (selection see P247) which is inverted and fed back to the n/f setpoint signal (see r481).</p> <p>Example: At a torque setpoint of 100% at the output of the n/f controller and a parameter value of 0.100 the speed setpoint is reduced by 10% of the rated motor frequency.</p> <p>Setting information:</p> <p>Kp = 0.000 = Droop inactive</p> <p>Kp > 0.000 and no external droop enable (refer to P584) = Droop is calculated (r249), however is not processed by the setpoint channel</p> <p>Kp > 0.000 and external droop enable (refer to P584) = Droop active</p> <p>The second setting should be selected for the master drive, if there is load equalization control between several motors. r249 can then be output, e. g. via the analog interface, without changing the main drive speed setpoint.</p> <p>Dependent parameter: P584 = Source of droop release</p> <p>Condition: P163 = 3, 4 (n/f control)</p> <p>MDS(4) Parameter</p> <p>Type=l2; PKW: 1HEX=0.001 PcD: 4000HEX=0.25</p>	0.000 to 0.499	4 i001=0.000 i002=0.000 i003=0.000 i004=0.000	3 / BR 3 / BR
r249 F9Hex	<p>n/f(Droop)</p> <p>Output signal of the droop feedback; is subtracted from the supplementary setpoint 2 in the setpoint channel if the droop is enabled.</p> <p>Dependent parameter: P584 = Source of droop release</p> <p>Condition: P163 = 3, 4 (n/f control)</p> <p>Type=l2; PKW: 1HEX=0.01Hz PcD Gr.: 1</p>	[Hz]	-	3 / BR
P250 FAHex	<p>n damping Kd</p> <p>Damping compensation gain of the speed actual value to the setpoint of the torque-generating current.</p> <p>The speed actual value is smoothed (refer to P251), differentiated, and evaluated with this factor (P250) and subtracted from Isq (set) (r246).</p> <p>For torque control (P163 = 5), for a slave drive (P587 = 1), and with the speed controller feed-forward control disabled (P243 = 0.0 %), the damping compensation operates with the speed actual value (r222).</p> <p>For n/f control (as master drive), the damping operates with the n/f control error (r223). The characteristics correspond to a smoothed D component of the n/f controller.</p> <p>The result (r251) is only injected after the torque limiting; otherwise, it would not be effective for the torque control.</p> <p>Condition: P163 = 3, 4, 5 (vector control types)</p> <p>MDS(4) Parameter</p> <p>Type=O2; PKW: 1HEX=0.01 PcD: 4000HEX=64</p>	0.00 to 125.00	4 i001=0.00 i002=0.00 i003=0.00 i004=0.00	3 / BR 3 / BR
P251 FBHex	<p>Smooth. n-damping</p> <p>Smoothing time constant of the damping compensation of the speed actual value to the setpoint of the torque-generating current</p> <p>Condition: P163 = 3, 4, 5 (vector control types)</p> <p>MDS(4) parameter</p> <p>Type=O2; PKW: 1HEX=0.1 ms PcD Gr.: 0</p>	0.0 to 200.0 [ms]4	4 i001=10.0 i002=10.0 i003=10.0 i004=10.0	3 / BR 3 / BR
r252 FCHex	<p>dlsq (damping)</p> <p>Damping compensation output and supplementary setpoint of the torque-generating current components at the Isq controller input.</p> <p>Condition: P163 = 3, 4, 5 (vector control types)</p> <p>Analog output: 100% @ Parameter Value = 4*P102</p> <p>Type=l2; PKW: 1HEX=0.1A PcD Gr.: 2</p>	[A]	- -	3 / BR

PNU	Parameter Name in OP1	Range [Unit]	# of. Indices	read: write:
*:conf-P	Description	Value texts	Factory Settings.	/ /
P253 FDHex	<p>Current Reg Gain</p> <p>Proportional gain of the PI current controllers (flux and torque generating current components, respectively) in the range of the asynchronous operation of the modulator.</p> <p>The adaptation of this gain is automatically performed depending on the pulse frequency</p> <p>Pre-set during automatic parameterization (P052 = 6) and during motor data identification (P052 = 7, 8).</p> <p>Note:</p> <p>After the pulse frequency or motor parameter has been changed, the automatic parameterization (parameter setting) or motor identification should be repeated in order to precisely set the controller.</p> <p>Condition: P163 = 3, 4, 5 (Vector control modes)</p> <p>MDS(4) Parameter</p> <p>Type=O2; PKW: 1HEX=0.001 PcD: 4000HEX=4</p>	0.000 to 2.000	4 i001=0.150 i002=0.150 i003=0.150 i004=0.150	3 / BR 3 / BR
P254 FEHex	<p>Current Reg Time</p> <p>Integral time constant of the PI current controllers (flux and torque generating current components, respectively) in the range of the asynchronous operation of the modulator.</p> <p>Pre-set during automatic parameterization (P052 = 6) and during motor data identification (P052 = 7, 8).</p> <p>Condition: P163 = 3, 4, 5 (Vector control modes)</p> <p>MDS(4) Parameter</p> <p>Type=O2; PKW: 1HEX=0.1ms PcD Gr.: 0</p>	2.0 to 200.0 [ms]	4 i001=10.0 i002=10.0 i003=10.0 i004=10.0	3 / BR 3 / BR
r255 FFHex	<p>Isd(set,smo'd)</p> <p>Setpoint signal of the flux generating current component at the input of the Isd controller; limited by the maximum current (r174).</p> <p>Condition: P163 = 3, 4, 5 (Vector control modes)</p> <p>Analog Output: 100% @ Parameter Value=4*P102</p> <p>Type=I2; PKW: 1HEX=0.1A PcD Gr.: 2</p>	[A]	-	3 / BR
r256 100Hex	<p>Isd(act)</p> <p>Actual value of the flux generating current component</p> <p>Condition: P163 = 3, 4, 5 (Vector control modes)</p> <p>Analog Output: 100% @ Parameter Value=4*P102</p> <p>Type=I2; PKW: 1HEX=0.1A PcD Gr.: 2</p>	[A]	-	3 / BR
P261 105Hex	<p>Smooth Isq</p> <p>Time constant for smoothing the torque generating current component (r264).</p> <p>Pre-set during automatic parameterization (P052 = 6) and during motor data identification (P052 = 7, 8).</p> <p>Related display parameter: r263 (Isq(set,smo'd))</p> <p>Condition: P163 = 0, 1 (V/Hz modes except textile applications)</p> <p>MDS(4) Parameter</p> <p>Type=O2; PKW: 1HEX=1.0ms PcD Gr.: 0</p>	0 to 3200 [ms]	4 i001=2000 i002=2000 i003=2000 i004=2000	3 / BR 3 / BR

PNU	Parameter Name in OP1	Range [Unit]	# of. Indices	read: <input type="checkbox"/> write: <input type="checkbox"/>
*:conf-P	Description	Value texts	Factory Settings.	
r263 107Hex	Isq(set,smo'd) Smoothed actual value of the torque generating current component For P163 = 1 (V/Hz mode): Smoothed actual value of the torque generating current component; is used for the slip compensation. For P163 = 3, 4, 5 (Vector control modes): Smoothed setpoint signal of the controller for the torque generating current component; smoothing is only active in the field weakening range. Dependent parameter: P261 (Smoothing of Isq) Condition: P163 = 1, 3, 4, 5 (V/Hz modes, Vector control modes) Analog Output: 100% @ Parameter Value=4*P102 Type=I2; PKW: 1HEX=0.1A PcD Gr.: 2	[A]	-	3 / BR
r264 108Hex	Isq(act) Actual value of the torque generating current component Analog Output: 100% @ Parameter Value=4*P102 Type=I2; PKW: 1HEX=0.1A PcD Gr.: 2	[A]	-	3 / BR
P270 10EHex	Resist Cable Resistance of the cable between the drive and the motor in % of the rated motor impedance; is part of P272. $\text{Rated motor-impedance: } Z_N = \frac{V_N}{1,732 \cdot I_N} = \frac{P101}{1,732 \cdot P102}$ Condition: P163 = 3, 4, 5 (Vector control modes) Must be entered before motor identification (P052 = 7, 8)! MDS(4) Parameter Type=O2; PKW: 1HEX=0.01% PcD: 4000HEX=25%	0.00 to 40.00 [%]	4 i001=0.00 i002=0.00 i003=0.00 i004=0.00	3 / BR 3 / BR
r271 10FHex	Resist Stator ++ Total 'Stator' resistance of the drive in % of the rated motor impedance Contains: Stator resistance of the motor and cable resistance between drive and motor If a KTY 84 sensor of the motor is connected, the value of this parameter is adapted with the motor temperature. Condition: P163 = 3, 4, 5 (Vector control modes) Analog Output: 100% @ Parameter Value=25.00% Type=O2; PKW: 1HEX=0.01% PcD: 4000HEX=25%	[%]	-	3 / BR
P272 110Hex	ResistStator+Cab Total of the stator resistance of the motor and the cable resistance in % of rated motor impedance. Pre-set during automatic parameterization (P052 = 6). Measurement during motor data identification (P052 = 7, 8) (only if P100 = 0, 1) Condition: P310 = 0 (Temperature adaption inactive) Note: For P100 = 3 (motor type = sync.perm.), after a parameter has been changed, automatic parameterization must be selected to set the current controller. MDS(4) Parameter Type=O2; PKW: 1HEX=0.01% PcD: 4000HEX=25%	0.00 to 49.99 [%]	4 i001=3.00 i002=3.00 i003=3.00 i004=3.00	2 / BR 2 / BR

PNU	Parameter Name in OP1	Range [Unit]	# of. Indices	read: write:
*:conf-P	Description	Value texts	Factory Settings.	/ /
r274 112Hex	T(sigma) Stator leakage time constant of the motor (including cable) Pre-set during automatic parameterization (P052 = 6) and during motor data identification (P052 = 7, 8). For induction motors, the values for d- and q axes are always identical. Disymmetry can only be achieved for P100 > 1 (motor type) (IEC,NEMA) as a result of the parameterization in P120 and P121. Indices: i001 = d axis i002 = q axis Analog Output: 100% @ Parameter Value=16384ms Type=O2; PKW: 1HEX=1.0ms PcD Gr.: 0	[ms] -d -q	-	3/ BR
P284 11CHex	f(AMP->cEMF-mod) Frequency in % of rated motor voltage where the control circuit switches from the current model to the counter EMF model during increasing output frequency. Condition: P163 = 3, 4, 5 (Vector control modes) MDS(4) Parameter Type=O2; PKW: 1HEX=0.1% PcD: 4000HEX=400%	2.0 to 799.9 [%]	4 i001=10.0 i002=10.0 i003=10.0 i004=10.0	3/ BR 3/ BR
P285 11DHex	f(cEMF->AMP-mod) Frequency in % of P284 where the control circuit switches from the counter EMF model to the current model during decreasing output frequency. Example: $\text{Frequency value [Hz]} = \frac{P107}{100\%} * \frac{P284}{100\%} * \frac{P285}{100\%}$ Condition: P163 = 3, 4, 5 (Vector control modes) MDS(4) Parameter Type=O2; PKW: 1HEX=0.1% PcD: 4000HEX=25%	1.0 to 99.0 [%]	4 i001=50.0 i002=50.0 i003=50.0 i004=50.0	3/ BR 3/ BR
r286 11EHex	act. Motor Model Active motor model. Parameter values: 0: Current model 1: Counter EMF model Dependent parameters: P284 (f(cEMF->I model)) P285 (f(I->cEMF model)) P287 (cEMF Reg Gain) Condition: P163 = 3, 4, 5 (Vector control modes) Analog Output: 100% @ Parameter Value=16384 Type=O2; PKW: 1HEX=1.0 PcD Gr.: 0	Curr Model Volt Model	-	3/ BR
P287 11FHex	cEMF Reg Gain Proportional gain of the PI controller for the counter EMF model @ rated motor voltage; at low voltage setpoints the gain is increased. Pre-set during automatic parameterization (P052 = 6) and during motor data identification (P052 = 7, 8). Description for Setting: The control circuit only operates in the current model if the parameter value is set to '0'. Condition: P163 = 3, 4, 5 (Vector control modes) MDS(4) Parameter Type=O2; PKW: 1HEX=0.001 PcD: 4000HEX=4	0.000 to 6.000	4 i001=0.250 i002=0.250 i003=0.250 i004=0.250	3/ BR 3/ BR
P289 121Hex	cEMF Reg Time Integral time constant of the PI controller for the counter EMF model. Pre-set during automatic parameterization (P052 = 6) and during motor data identification (P052 = 7, 8). Related display parameter: r292 (f(EMK-Reg.,i)) Condition: P163 = 3, 4, 5 (Vector control modes); MDS(4) Parameter Type=O2; PKW: 1HEX=0.1ms PcD Gr.: 0	4.0 to 999.9 [ms]	4 i001=50.0 i002=50.0 i003=50.0 i004=50.0	3/ BR 3/ BR

PNU	Parameter Name in OP1	Range [Unit]	# of. Indices	read: <input type="checkbox"/> write: <input type="checkbox"/>
*:conf-P	Description	Value texts	Factory Settings.	
r292 124Hex	f(cEMF Reg,i) Integral part of the counter EMF controller; in the operating range of the current model (r286 = 0) the value of this parameter is '0'. Analog Output: 100% @ Parameter Value=P420 Type=l2; PKW: 1HEX=0.01Hz PcD Gr.: 1	[Hz]	-	3 / BR
P294 126Hex	Slip Comp Gain Proportional gain of the slip compensation (also allowing for the rotor temperature) Description for Setting: 0.0%: Slip compensation off 50 - 70%: Full slip compensation at cool motor (partial load) 100%: Full slip compensation at warm motor (full load) ATTENTION: Name plate data for rated motor current (P102), speed (P108) and -frequency (P107) must be entered correctly and completely. Condition: P163 = 1 (V/Hz mode) MDS(4) Parameter Type=O2; PKW: 1HEX=0.1% PcD: 4000HEX=400%	0.0 to 400.0 [%]	4 i001=0.0 i002=0.0 i003=0.0 i004=0.0	2 / BR 2 / BR
r295 127Hex	Motor Rtd Slip Rated motor slip in % of rated motor frequency (P108). Analog Output: 100% @ Parameter Value=25.0% Condition: P100 = 0, 1 (motor type = IEC, NEMA) Type=O2; PKW: 1HEX=0.01% PcD: 4000HEX=25%	[%]	-	3 / BR
r296 128Hex	Slip Frequency Actual slip frequency of the motor P163 = 0 (V/Hz mode with speed control): P163 = 1 (V/Hz mode): P163 = 3, 4, 5 (Vector control modes): Dependent parameters: P294 (Kp of the slip compensation) for P163 = 0 V/f cl. Analog Output: 100% @ Parameter Value=25% Type=l2; PKW: 1HEX=0.01% PcD: 4000HEX=25%	[%]	-	3 / BR
r297 129Hex	f(set,stator) Stator frequency setpoint signal Analog Output: 100% @ Parameter Value=P420 Type=l2; PKW: 1HEX=0.1Hz PcD Gr.: 1	[Hz]	-	3 / BR
P299 12BHex	Reson Damp Gain Proportional gain of the resonance damping circuit The resonant damping circuit is effective in a range from about 5 % to 70 % of rated motor frequency. Description for setting: Too high parameter values cause instability (forward control effect). Note: The resonance damping circuit damps oscillations of the active current. These oscillations mainly happen during no load operation. The parameter can not be used to optimize the response behavior of V/Hz mode with speed control (P163 = 0). Related display parameters: r264 (Isq(act)) r301 (f (Resonance damping)). Condition: P163 = 0, 1 (V/Hz modes except textile applications) MDS(4) Parameter Type=O2; PKW: 1HEX=0.01 PcD Gr.: 0	0.00 to 0.99	4 i001=0.00 i002=0.00 i003=0.00 i004=0.00	3 / BR 3 / BR

PNU	Parameter Name in OP1	Range [Unit]	# of. Indices	read: write:
*:conf-P	Description	Value texts	Factory Settings.	/ /
P300 12CHex	Damp Gain Proportional gain of the resonance damping circuit at frequency control The resonance damping circuit damps oscillations in the low speed range. Related display parameter: r301 (f (Resonance damping)) Condition: P163 = 3 (Frequency control) MDS(4) Parameter Type=O2; PKW: 1HEX=0.001 PcD Gr.: 0	0.000 to 10.000	4 i001=0.075 i002=0.075 i003=0.075 i004=0.075	3 / BR 3 / BR
r301 12DHex	f(Reson Damp) Output frequency of the resonance damping circuit Analog Output: 100% @ Parameter Value=P420 Type=I2; PKW: 1HEX=0.1Hz PcD Gr.: 1	[Hz]	-	3 / BR
P302 12EHex	SmoothDCBusVolts Time constant for smoothing the DC link bus voltage (r304) for use in the Vd correction circuit. The smoothing is exponentially related to the parameter value. $T_{smooth} \sim 2^{Parameter\ value}$ Related display parameter: r304 (Vd(act,smooth)) Note: if P302 = 16, P304 displays the DC bus voltage calculated from P071 (Line Voltage) MDS(4) Parameter Type=O2; PKW: 1HEX=1.0 PcD Gr.: -	0 to 16	4 i001=9 i002=9 i003=9 i004=9	3 / BR 3 / BR
r303 12FHex	DC BusVolts(act) unfiltered actual value of the DC link bus voltage Analog Output: 100% @ Parameter Value=4*r307 Type=I2; PKW: 1HEX=1.0V PcD Gr.: 4	[V]	-	3 / BR
r304 130Hex	DCBusVolt(smo'd) Smoothed actual value of the DC bus voltage; smoothing see P302 Analog Output: 100% @ Parameter Value=4*r307 Type=O2; PKW: 1HEX=0.1V PcD Gr.: 4	[V]	-	3 / BR
r307 133Hex	Line Volts (AC) Rated line voltage For AC drives: Rated drive input voltage (P071). For DC inverters: fictive AC input voltage which would cause the DC voltage ($\frac{P071}{1,35}$). Analog Output: 100% @ Parameter Value=1638.4V Type=O2; PKW: 1HEX=0.1V PcD Gr.: 0	[V]	-	3 / BR
P308 134Hex	Sampling Time Base sampling time T0 of the n/f/T control and the V/Hz control. Description for Setting: <ul style="list-style-type: none"> Before reducing the sampling time the calculation time headroom should be checked (r725). A minimum headroom of 5 % should always be guaranteed to prevent the operation program a slow reaction. If fault message #42 'Calculation time' occurs, the sampling time must be increased. The calculation time loading also depends on the pulse frequency (P761). Type=O2; PKW: 1HEX=0.1ms PcD Gr.: 0	0.8 to 4.0 [ms]	- 1.2	3 / ABR 3 / A

PNU *:conf-P	Parameter Name in OP1 Description	Range [Unit] Value texts	# of. Indices Factory Settings.	read: <u> </u> / <u> </u> write: <u> </u> / <u> </u>
<p>P310 * 136Hex</p>	<p>RotResistTmpAdap Temperature adaption of the rotor- and stator resistances. Adaption operates at loads from approx. 5 % -10 % and in the range of the EMF model (r286 = 1) with a motor model. As this model is dependent on extremely accurate speed measured values, it is only activated for speed/torque control (P163 = 4, 5) and when a pulse encoder is connected (P208 = 1, 2). The adaption operates with a precise thermal motor simulation (3-mass model) outside of these conditions, e. g. for frequency control (P163 = 3) or in the current model range (r286 = 0). The best adaption results can be achieved for speed/torque control with an pulse tachometer and connected KTY sensor (connector X103). The output temperatures of the 3-mass model and the resistance values are reset, under the following conditions: If the drive temperature has increased or fallen since the last motor identification, if the power supply failed, if a motor data set was changed, parameters P310..P314 were changed, or the drive was re-commissioned (P52 = 2, 5). Setting corresponding to the actual motor temperature can be realized using KTY. A new motor identification run is recommended if there is no KTY available. The stator resistance (r271) can be adapted using the 3-mass model. In order to increase the accuracy of R(stator), before the motor identification run, the feeder resistance (P270) should be determined and entered. Parameter values: 0: Not active 1: Without KTY temperature sensor (not for P100 > 1) 2: With KTY temperature sensor Note: • All motor data (P100 .. P109) should be entered according to the motor name plate. • After parameter P310 has been activated, the motor series (P311) should be selected. In this case, a possibly known feeder resistance is entered in P270, the cooling type selected (P362) and a motor identification run should always be executed (P052 = 8 or 7,9), in order to determine the actual values of R(rotor) and R(stator). • The adaption is automatically calculated, just the same as without KTY sensor, if the sensor feeder cable is open-circuit, is short-circuited or if the PTC thermistor is activated (P361 = 1)! • When the EMF model is switched-out (P287 = 0 or P284 > f(max)), then only the 3-mass model operates for speed/torque control. These settings are not recommended, as the adaption accuracy is obtained from the combination with the electrical model. • A KTY sensor is also recommended for f control (P052 = 3) or speed/torque control with analog tachometer, as this also corrects deviations of the ambient temperature from 20°C, inaccuracies for the rated motor speed (P108: Name plate possibly inaccurate) as well as deviations from standard temperature rises (refer to P314). Dependencies: r009 motor temperature (P310 = 2) (measured stator winding temperature) P092 output filter (for sinusoidal filter: No modulation losses) P198 R(rotor) Ktemp r199 R(rotor) r271 R(stator,total) P272 R(stator+feeder cable) P311 motor series P312 motor weight P313 internal fan (for 1LA1, 1LA8 motors: Always present) P314 K(temp. rise.) P362 motor cooling (not for 1PH6 motors; always an external fan) Condition: P163 = 3, 4, 5 (Vector control types) MDS(4) Parameter Type=O2; PKW: 1HEX=1.0 PcD Gr.: -</p>	<p>0 to 2</p>	<p>4 i001=0 i002=0 i003=0 i004=0</p>	<p>3 / BR 3 / BR</p>

PNU	Parameter Name in OP1	Range [Unit]	# of. Indices	read: write:
*:conf-P	Description	Value texts	Factory Settings.	/ /
P311 137Hex	<p>Motor series</p> <p>Selects the motor series of the connected motor. When selecting one of the specified series (P311 > 0), known motor characteristics are automatically transferred: Inner fan type (P313) and the average temperature raise factor.</p> <p>Parameter values: 0: Unlisted motor 1: 1LA5 series 2: 1LA6 series 3: 1LA8 series 4: 1LA1 series 5: 1PH6 series</p> <p>Setting information: When selecting unlisted motors, P312 .. P314 can be individually adapted. This is only recommended, if the motor is unlisted but also, if for example, the motor weight (P312) or the temperature raise factor (P314) has to be changed over the basic setting. Then, it must be ensured that P313 is correctly set (inner fan)!</p> <p>Condition: P310 > 0 (temperature adaption active) P100 = 0, 1 (motor type = IEC, NEMA)</p> <p>MDS(4) Parameter Type=O2; PKW: 1HEX=1.0 PcD Gr.: -</p>	0 to 5 Unlisted motor 1LA5 1LA6 1LA8 1LA1 1PH6	4 i001=1 i002=1 i003=1 i004=1	3 / BR 3 / BR
P312 138Hex	<p>Motor Weight</p> <p>Total motor weight.</p> <p>The value can be taken from the motor catalog. The more accurately that it is known, then it is easier to estimate the thermal mass relationships.</p> <p>Pre-assignment for automatic parameterization (P052 = 6, 7, 8)</p> <p>Condition: Unlisted motor (P311 = 0)</p> <p>MDS(4) Parameter Type=O2; PKW: 1HEX=1.0 PcD Gr.: 0</p>	5 to 9999 [kg]	4 i001=40 i002=40 i003=40 i004=40	3 / BR 3 / BR
P313 139Hex	<p>Internal fan</p> <p>1LA1 and 1LA8 motor series have a special inner fan (not to be confused with the fan at the end of the motor shaft).</p> <p>Motor with inner fan and P311 = 0 (unlisted motor) ⇒ P313 = 1 Motor without inner fan and P311 = 0 (unlisted motor) ⇒ P313 = 0</p> <p>For P311 <> 0, P313 is automatically pre-assigned; manual changes remain ineffective.</p> <p>Parameter values: 0: Without inner fan 1: With inner fan</p> <p>MDS(4) Parameter Type=O2; PKW: 1HEX=1.0 PcD Gr.: -</p>	0 to 1 without with	4 i001=0 i002=0 i003=0 i004=0	3 / BR 3 / BR
P314 13AHex	<p>Overtemp. Factor</p> <p>Evaluates the internally used standard temperature rises for sinusoidal operation (line supply temperature rises - direct on-line temperature rises). There is only one factor to simultaneously evaluate the temperature rises of the stator (80K), rotor (100 K) and iron (50 K).</p> <p>The temperature rises due to converter operation (modulation losses), which are a function of both the pulse frequency (P761) as also the output filter (P92 = 2) are automatically taken into account.</p> <p>If the motor rotor temperature rise is known, then the relationship to 100 K can be entered here. If only that of the stator is known, the ratio to 80 K should be entered.</p> <p>Note:</p> <ul style="list-style-type: none"> For 1PH6 motors (refer to P311), internally a value of 130.0 % is automatically assumed, i. e. the parameter has no effect. The factor is 100 % for 1LA motors <p>Condition: Unlisted motor (P311 = 0)</p> <p>MDS(4) Parameter Type=O2; PKW: 1HEX=1.0 PcD: 4000HEX=400 %</p>	25.0 to 200.0 [%]	4 i001=100.0 i002=100.0 i003=100.0 i004=100.0	3 / BR 3 / BR

11.7 Functions

PNU *:conf-P	Parameter Name in OP1 Description	Range [Unit] Value texts	# of. Indices Factory Settings.	read: / write: /
r333 14DHex	<p>Mot ID Status</p> <p>Displays the actual measuring step of the motor data identification; see also Section „Function selection“ in the Operating Instructions, Part 2;</p> <p>0: not activated 1: delay time for fan</p> <p>The '100' digit displays the type of measurement: 1xx: ground fault test 2xx: test pulses measurement 3xx: leakage inductance measurement 4xx: DC measurement 5xx: tachometer test 6xx: no load measurement 7xx: optimization of the n/f controller</p> <p>For a ground-fault test and test pulse measurement for converters switched in parallel, the ones position allows a differentiation to be made as to which partial inverter is actually executing the measurement 1x1: ground fault test, inverter 1 1x2: ground fault test, inverter 2 2x1: test pulse measurement, inverter 1 2x2: test pulse measurement, inverter 2 2x3: test pulse measurement of both inverters</p> <p>The '10' digit separates the measurement into several steps; the detailed meaning depends of the '100' digit: 10x: ground fault test selected 11x: no transistor ON 12x: transistor V+ ON 13x: transistor V- ON 14x: transistor U+ ON 15x: transistor U- ON 16x: transistor W+ ON 17x: transistor W- ON 20x: test pulse measurement selected 21x: U+, V-, W- triggered 22x: U-, V+, W+ triggered 23x: U-, V-, W+ triggered 24x: U+, V+, W- triggered 25x: U+, V-, W+ triggered 26x: U-, V+, W- triggered 300: leakage measurement selected 310, 320: measurement in phase direction V 330, 340: measurement in phase direction W 350, 360: measurement in phase direction U 40x: DC measurement selected 41x: measurement in the direction of phase U 42x: measurement in the direction of phase V 43x: measurement in the direction of phase W 44x: saving parameter values 50x, 60x, 70x: function selected 51x, 61x, 71x: drive is accelerating 52x, 62x, 72x: measurement during constant speed 53x, 63x, 73x: measurement during n/f setpoint steps 54x, 64x, 74x: oscillation test 55x, 65x, 75x: saving parameter values</p> <p>The '1' digit displays more details of the steps: 4x0, 5x0, 6x0, 7x0: not active 4x1, 5x1, 6x1, 7x1: waiting 4x2, 5x2, 6x2, 7x2: data recording 4x3, 5x3, 6x3, 7x3: data evaluation 4x4, 5x4, 6x4, 7x4: saving parameter values</p> <p>Type=O2; PKW: 1HEX=1.0 PcD Gr.: 0</p>		-	2 / BR

PNU	Parameter Name in OP1	Range [Unit]	# of. Indices	read: write:																
*:conf-P	Description	Value texts	Factory Settings.																	
r344 158Hex	<p>TestPulsesResult</p> <p>Test pulse results; bit coded display.</p> <p>The index displays the number of the test pulse and the switching status: '1' means, that the described event has happened during the measurement.</p> <table border="1" style="margin-left: 20px;"> <tr> <td>15</td><td>14</td><td>13</td><td>12</td><td>11</td><td>10</td><td>9</td><td>8</td> </tr> <tr> <td>7</td><td>6</td><td>5</td><td>4</td><td>3</td><td>2</td><td>1</td><td>0</td> </tr> </table> <p>Bit 0: VCE W (L3) Bit 1: VCE V (L2) Bit 2: VCE U (L1) Bit 3: Overcurrent Bit 4: VCE W (L3) paralleled inverter #2 Bit 5: VCE V (L2) paralleled inverter #2 Bit 6: VCE U (L1) paralleled inverter #2 Bit 7: Result O. K. Bit 8: lw > 0 Bit 9: iw < 0 Bit 10: lu > 0 Bit 11: lu < 0 Bits 12, 13, 14: switching status of the inverter phase legs W, V and U '1': output terminal connected to + DC bus '0': output terminal connected to - DC bus Bit 15: not used</p> <p>Indices: i00n Δ Tp0n, n = 1 to 18</p> <p>Type=V2; PKW: 1HEX=1.0 PcD Gr.: 0</p>	15	14	13	12	11	10	9	8	7	6	5	4	3	2	1	0		18	3 / BR
15	14	13	12	11	10	9	8													
7	6	5	4	3	2	1	0													
r345 159Hex	<p>TachTest Result</p> <p>Result of the tachometer test. The test is completely performed during P052 = 8, 9, during P052 = 10, 12 parts of the test are performed.</p> <p>Parameter values:</p> <ol style="list-style-type: none"> 0: Test not active or not yet completed 1: Tachometer signal o. k. 2: The scaling of the analog tachometer (P210) has automatically be performed (only P052 = 8, 9). 3: The calculated scaling of the analog tachometer has been limited to the allowed value (only P052 = 8, 9). 4: No speed signal has been received. 5: The polarity of the speed signal is incorrect 6: One track signal of the encoder is missing 7: The actual scaling of the analog tachometer (P210) is incorrect; it is proposed to run the no load measurement program (P052=9). 8: The number of pulses of the encoder (P209) is set incorrectly. <p>Condition: P163 = 3, 4, 5 (Vector control modes)</p> <p>Type=O2; PKW: 1HEX=1.0 PcD Gr.: 0</p>	<p>No Result O.K. Gain corr Gain limit Signal miss Polarity Track miss Gain wrong Pulse #</p>	-	2 / BR																
P346 15AHex	<p>n/f RegDyn(set)</p> <p>Setpoint for the dynamic behavior of the speed controller; is used for the optimization for the dimensioning of the n/f controller (P052 = 10 or 8). 100% result in excellent dynamic behavior 10% result in the least possible dynamic behavior</p> <p>Note: a change will only become active after the n/f controller optimization program was run (P052 = 8, 10).</p> <p>Condition: P163 = 3, 4, 5 (Vector control modes); MDS(4) Parameter</p> <p>Type=O2; PKW: 1HEX=1.0% PcD Gr.: -</p>	<p>10 to 200 [%]</p>	<p>4 i001=50 i002=50 i003=50 i004=50</p>	<p>2 / BR 2 / BR</p>																

PNU	Parameter Name in OP1	Range [Unit]	# of. Indices	read: <input type="checkbox"/> write: <input type="checkbox"/>
*:conf-P	Description	Value texts	Factory Settings.	
P347 15BHex	<p>n/f RegDyn(act)</p> <p>Actual value of the dynamic behavior of the speed controller; this value has been entered by the n/f controller optimization program (P052 = 8, 10) from P346; if needed the value was reduced. 100% result in excellent dynamic behavior. Condition: P163 = 3, 4, 5 (Vector control modes); MDS(4) Parameter Type=O2; PKW: 1HEX=1.0% PcD Gr.: -</p>	0 to 200 [%]	4 i001=0 i002=0 i003=0 i004=0	2 / BR 4 / B
P348 15CHex	<p>n/f Reg Osc Freq</p> <p>Oscillating frequency measured by the oscillation monitor of the n/f control circuit. A value of '0' means that no oscillations have been monitored. The value is measured during the n/f controller optimization (P052 = 8, 10). Condition: P163 = 3, 4, 5 (Vector control modes); MDS(4) Parameter Type=O2; PKW: 1HEX=0.1Hz PcD Gr.: 1</p>	0.0 to 100.0 [Hz]	4 i001=0.0 i002=0.0 i003=0.0 i004=0.0	2 / BR 4 / B
P354 162Hex	<p>Ground Flt Test</p> <p>Ground fault test; this is not a protective function according to any standard. Parameter values: 0 = no ground fault test to be performed except during parameter identification 1 = ground fault test will be performed after the next ON command; afterwards the parameter is reset to '0' 2 = ground fault test to be performed after every ON command 3 = ground fault test is always OFF, even during parameter identification Note: During motor data identification (P052 = 7) a ground fault test is performed if P354 = 0, 1, or 2. Type=O2; PKW: 1HEX=1.0 PcD Gr.: -</p>	0 to 3	- 1	3 / BR 3 / BR

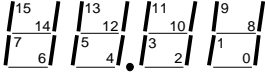
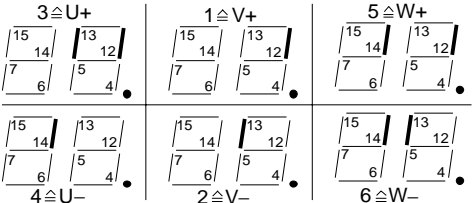
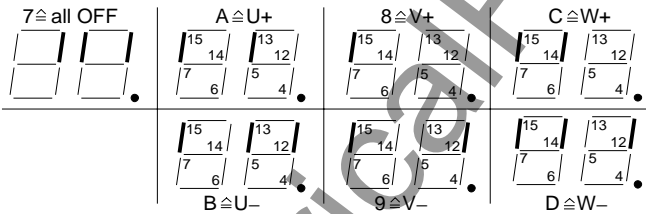
PNU *:conf-P	Parameter Name in OP1 Description	Range [Unit] Value texts	# of. Indices Factory Settings.	read: write: / /
<p>r358</p> <p>166Hex</p>	<p>GrdFltTestResult</p> <p>Results of the ground fault test</p> <p>Bit-coded display of the reason which has caused the break of the test.</p>  <p>Parameter values:</p> <ul style="list-style-type: none"> Bit 0 =1: VCE phase W Bit 1 =1: VCE phase V Bit 2 =1: VCE phase U Bit 3 =1: overcurrent Bit 8 =1: negative lw Bit 9 =1: positive lw Bit 10 =1: negative lu Bit 11 =1: positive lu <p>ATTENTION!</p> <p>The semiconductor which was triggered or where the fault occurred is coded using Bits 12 to 14 or the highest value nibble on the OP1.</p> <p>Individual converter or Inverter 1 in the parallel circuit:</p>  <p>Bits 12 to 14 all OFF: no semiconductor was in ON-state.</p> <p>Inverter 2 in the parallel circuit:</p>  <p>Type=V2; PKW: 1HEX=1.0 PcD Gr.: 0</p>		<p>–</p>	<p>3 / BR</p>
<p>P360</p> <p>*</p> <p>168Hex</p>	<p>Mot Tmp Warning</p> <p>Limit for the warning message 'Motor overtemperature' (P625).</p> <p>Condition: P361 > 1 (only for temperature measurement via KTY sensor)</p> <p>Example: for isolation class B: <= 110°C; EXd <= 100°C for isolation class F: <= 145°C; EXd <= 145°C</p> <p>Description for setting: a parameter value > 0 activates this function.</p> <p>MDS(4) Parameter</p> <p>Type=l2; PKW: 1HEX=1.0°C PcD Gr.: -</p>	<p>0 to 160 [°C]</p>	<p>4</p> <p>i001=0 i002=0 i003=0 i004=0</p>	<p>2 / BR 2 / BR</p>

PNU *:conf-P	Parameter Name in OP1 Description	Range [Unit] Value texts	# of. Indices Factory Settings.	read: <input type="checkbox"/> write: <input type="checkbox"/>
P361 * 169Hex	Mot Tmp Fault Limit for the fault message 'Motor overtemperature' (P626) and selection of the thermistor temperature measurement, respectively. Example: for isolation class B: <=110°C; EXd <= 100°C for isolation class F: <=145°C; EXd <= 145°C Setting instructions: <ul style="list-style-type: none"> The PTC evaluation is activated by setting value 1. The PTC thermistor evaluation identifies an overtemperature condition, if the PTC thermistor resistance is >1.5 kΩ. The temperature sensing is activated using a KTY sensor for a setting value > 1. MDS(4) Parameter Type=I2; PKW: 1HEX=1.0°C PcD Gr.: 0	0 to 300 [°C]	4 i001=0 i002=0 i003=0 i004=0	2 / BR 2 / BR
P362 * 16AHex	Motor Cooling Motor cooling The motor cooling type has an effect on the calculation of the permissible duty cycle, as well as on the accuracy of the 3-mass model for temperature adaption of the rotor- and stator resistances (P310). Note: For P311 = 5 = 1PH6 motor series, for the temperature adaption, it is automatically assumed that the motor is force-cooled. Parameter values: 0: self cooled 1: forced cooling MDS(4) Parameter Type=O2; PKW: 1HEX=1.0 PcD Gr.: -	0 to 1 self cooled forced vent	4 i001=0 i002=0 i003=0 i004=0	2 / BR 2 / BR

PNU	Parameter Name in OP1	Range [Unit]	# of. Indices	read: write:																																																																																																																																																																																																																																																																																																																																																																																										
*:conf-P	Description	Value texts	Factory Settings.																																																																																																																																																																																																																																																																																																																																																																																											
P363	Mot ThermT-Const	0 to 16000	4	2 / BR																																																																																																																																																																																																																																																																																																																																																																																										
16BHex	Thermal time constant of the motor Description for Setting: The i ² t calculation is activated by a parameter value >= 100 sec Example: For a 2-pole 1LA5063 motor, the value should be set to: 8 min (from the table)*60 s/min = 480 s Typical thermal time constants for Siemens motors (in min.):	[s]	i001=100 i002=100 i003=100 i004=100	2 / BR																																																																																																																																																																																																																																																																																																																																																																																										
	<table border="1"> <thead> <tr> <th>Type</th> <th>2-pole</th> <th>4-pole</th> <th>6-pole</th> <th>8-pole</th> <th>10-pole</th> <th>12-pole</th> </tr> </thead> <tbody> <tr><td>1LA5063</td><td>8</td><td>13</td><td>-</td><td>-</td><td>-</td><td>-</td></tr> <tr><td>1LA5070</td><td>8</td><td>10</td><td>12</td><td>-</td><td>-</td><td>-</td></tr> <tr><td>1LA5073</td><td>8</td><td>10</td><td>12</td><td>-</td><td>-</td><td>-</td></tr> <tr><td>1LA5080</td><td>8</td><td>10</td><td>12</td><td>-</td><td>-</td><td>-</td></tr> <tr><td>1LA5083</td><td>10</td><td>10</td><td>12</td><td>-</td><td>-</td><td>-</td></tr> <tr><td>1LA5090</td><td>5</td><td>9</td><td>12</td><td>12</td><td>-</td><td>-</td></tr> <tr><td>1LA5096</td><td>6</td><td>11</td><td>12</td><td>14</td><td>-</td><td>-</td></tr> <tr><td>1LA5106</td><td>8</td><td>12</td><td>12</td><td>16</td><td>-</td><td>-</td></tr> <tr><td>1LA5107</td><td>-</td><td>12</td><td>-</td><td>16</td><td>-</td><td>-</td></tr> <tr><td>1LA5113</td><td>14</td><td>11</td><td>13</td><td>12</td><td>-</td><td>-</td></tr> <tr><td>1LA5130</td><td>11</td><td>10</td><td>13</td><td>10</td><td>-</td><td>-</td></tr> <tr><td>1LA5131</td><td>11</td><td>10</td><td>-</td><td>-</td><td>-</td><td>-</td></tr> <tr><td>1LA5133</td><td>-</td><td>10</td><td>14</td><td>10</td><td>-</td><td>-</td></tr> <tr><td>1LA5134</td><td>-</td><td>-</td><td>16</td><td>-</td><td>-</td><td>-</td></tr> <tr><td>1LA5163</td><td>15</td><td>19</td><td>20</td><td>12</td><td>-</td><td>-</td></tr> <tr><td>1LA5164</td><td>15</td><td>-</td><td>-</td><td>-</td><td>-</td><td>-</td></tr> <tr><td>1LA5166</td><td>15</td><td>19</td><td>20</td><td>14</td><td>-</td><td>-</td></tr> <tr><td>1LA5183</td><td>25</td><td>30</td><td>-</td><td>-</td><td>-</td><td>-</td></tr> <tr><td>1LA5186</td><td>-</td><td>30</td><td>40</td><td>45</td><td>-</td><td>-</td></tr> <tr><td>1LA5206</td><td>30</td><td>-</td><td>45</td><td>-</td><td>-</td><td>-</td></tr> <tr><td>1LA5207</td><td>30</td><td>35</td><td>45</td><td>50</td><td>-</td><td>-</td></tr> <tr><td>1LA6220</td><td>-</td><td>40</td><td>-</td><td>55</td><td>-</td><td>-</td></tr> <tr><td>1LA6223</td><td>35</td><td>40</td><td>50</td><td>55</td><td>-</td><td>-</td></tr> <tr><td>1LA6253</td><td>40</td><td>45</td><td>50</td><td>60</td><td>-</td><td>-</td></tr> <tr><td>1LA6280</td><td>40</td><td>50</td><td>55</td><td>65</td><td>-</td><td>-</td></tr> <tr><td>1LA6283</td><td>40</td><td>50</td><td>55</td><td>65</td><td>-</td><td>-</td></tr> <tr><td>1LA6310</td><td>45</td><td>55</td><td>60</td><td>75</td><td>-</td><td>-</td></tr> <tr><td>1LA6313</td><td>-</td><td>55</td><td>60</td><td>75</td><td>-</td><td>-</td></tr> <tr><td>1LA831.</td><td>35</td><td>40</td><td>45</td><td>45</td><td>50</td><td>50</td></tr> <tr><td>1LA835.</td><td>40</td><td>45</td><td>50</td><td>50</td><td>55</td><td>55</td></tr> <tr><td>1LA840.</td><td>45</td><td>50</td><td>55</td><td>55</td><td>60</td><td>60</td></tr> <tr><td>1LA845.</td><td>55</td><td>55</td><td>60</td><td>60</td><td>70</td><td>70</td></tr> <tr><td>1LL831.</td><td>25</td><td>25</td><td>30</td><td>30</td><td>35</td><td>35</td></tr> <tr><td>1LL835.</td><td>30</td><td>30</td><td>35</td><td>35</td><td>40</td><td>40</td></tr> <tr><td>1LL840.</td><td>35</td><td>35</td><td>35</td><td>35</td><td>40</td><td>40</td></tr> <tr><td>1LL845.</td><td>40</td><td>35</td><td>40</td><td>40</td><td>45</td><td>45</td></tr> <tr><td>1LA135.</td><td>30</td><td>35</td><td>40</td><td>-</td><td>-</td><td>-</td></tr> <tr><td>1LA140.</td><td>35</td><td>40</td><td>45</td><td>45</td><td>-</td><td>-</td></tr> <tr><td>1LA145.</td><td>40</td><td>45</td><td>50</td><td>50</td><td>55</td><td>55</td></tr> <tr><td>1LA150.</td><td>50</td><td>50</td><td>55</td><td>55</td><td>65</td><td>65</td></tr> <tr><td>1LA156.</td><td>60</td><td>55</td><td>60</td><td>60</td><td>70</td><td>70</td></tr> <tr><td>1LL135.</td><td>20</td><td>20</td><td>25</td><td>-</td><td>-</td><td>-</td></tr> <tr><td>1LL140.</td><td>25</td><td>25</td><td>30</td><td>30</td><td>-</td><td>-</td></tr> <tr><td>1LL145.</td><td>30</td><td>30</td><td>30</td><td>30</td><td>35</td><td>35</td></tr> <tr><td>1LL150.</td><td>35</td><td>30</td><td>35</td><td>35</td><td>40</td><td>40</td></tr> <tr><td>1LL156.</td><td>40</td><td>35</td><td>35</td><td>35</td><td>40</td><td>40</td></tr> <tr><td>Type n_n=</td><td>3000</td><td>2000</td><td>1500</td><td>1000</td><td>500</td><td>1/min</td></tr> <tr><td>1PH610.</td><td>25</td><td>25</td><td>25</td><td>20</td><td>-</td><td>-</td></tr> <tr><td>1PH613.</td><td>30</td><td>30</td><td>30</td><td>30</td><td>-</td><td>-</td></tr> <tr><td>1PH616.</td><td>-</td><td>35</td><td>35</td><td>35</td><td>-</td><td>-</td></tr> <tr><td>1PH618.</td><td>40</td><td>40</td><td>40</td><td>40</td><td>40</td><td>-</td></tr> <tr><td>1PH620.</td><td>40</td><td>40</td><td>40</td><td>40</td><td>40</td><td>-</td></tr> <tr><td>1PH622.</td><td>40</td><td>40</td><td>40</td><td>40</td><td>40</td><td>-</td></tr> </tbody> </table>	Type	2-pole	4-pole	6-pole	8-pole	10-pole	12-pole	1LA5063	8	13	-	-	-	-	1LA5070	8	10	12	-	-	-	1LA5073	8	10	12	-	-	-	1LA5080	8	10	12	-	-	-	1LA5083	10	10	12	-	-	-	1LA5090	5	9	12	12	-	-	1LA5096	6	11	12	14	-	-	1LA5106	8	12	12	16	-	-	1LA5107	-	12	-	16	-	-	1LA5113	14	11	13	12	-	-	1LA5130	11	10	13	10	-	-	1LA5131	11	10	-	-	-	-	1LA5133	-	10	14	10	-	-	1LA5134	-	-	16	-	-	-	1LA5163	15	19	20	12	-	-	1LA5164	15	-	-	-	-	-	1LA5166	15	19	20	14	-	-	1LA5183	25	30	-	-	-	-	1LA5186	-	30	40	45	-	-	1LA5206	30	-	45	-	-	-	1LA5207	30	35	45	50	-	-	1LA6220	-	40	-	55	-	-	1LA6223	35	40	50	55	-	-	1LA6253	40	45	50	60	-	-	1LA6280	40	50	55	65	-	-	1LA6283	40	50	55	65	-	-	1LA6310	45	55	60	75	-	-	1LA6313	-	55	60	75	-	-	1LA831.	35	40	45	45	50	50	1LA835.	40	45	50	50	55	55	1LA840.	45	50	55	55	60	60	1LA845.	55	55	60	60	70	70	1LL831.	25	25	30	30	35	35	1LL835.	30	30	35	35	40	40	1LL840.	35	35	35	35	40	40	1LL845.	40	35	40	40	45	45	1LA135.	30	35	40	-	-	-	1LA140.	35	40	45	45	-	-	1LA145.	40	45	50	50	55	55	1LA150.	50	50	55	55	65	65	1LA156.	60	55	60	60	70	70	1LL135.	20	20	25	-	-	-	1LL140.	25	25	30	30	-	-	1LL145.	30	30	30	30	35	35	1LL150.	35	30	35	35	40	40	1LL156.	40	35	35	35	40	40	Type n _n =	3000	2000	1500	1000	500	1/min	1PH610.	25	25	25	20	-	-	1PH613.	30	30	30	30	-	-	1PH616.	-	35	35	35	-	-	1PH618.	40	40	40	40	40	-	1PH620.	40	40	40	40	40	-	1PH622.	40	40	40	40	40	-			
Type	2-pole	4-pole	6-pole	8-pole	10-pole	12-pole																																																																																																																																																																																																																																																																																																																																																																																								
1LA5063	8	13	-	-	-	-																																																																																																																																																																																																																																																																																																																																																																																								
1LA5070	8	10	12	-	-	-																																																																																																																																																																																																																																																																																																																																																																																								
1LA5073	8	10	12	-	-	-																																																																																																																																																																																																																																																																																																																																																																																								
1LA5080	8	10	12	-	-	-																																																																																																																																																																																																																																																																																																																																																																																								
1LA5083	10	10	12	-	-	-																																																																																																																																																																																																																																																																																																																																																																																								
1LA5090	5	9	12	12	-	-																																																																																																																																																																																																																																																																																																																																																																																								
1LA5096	6	11	12	14	-	-																																																																																																																																																																																																																																																																																																																																																																																								
1LA5106	8	12	12	16	-	-																																																																																																																																																																																																																																																																																																																																																																																								
1LA5107	-	12	-	16	-	-																																																																																																																																																																																																																																																																																																																																																																																								
1LA5113	14	11	13	12	-	-																																																																																																																																																																																																																																																																																																																																																																																								
1LA5130	11	10	13	10	-	-																																																																																																																																																																																																																																																																																																																																																																																								
1LA5131	11	10	-	-	-	-																																																																																																																																																																																																																																																																																																																																																																																								
1LA5133	-	10	14	10	-	-																																																																																																																																																																																																																																																																																																																																																																																								
1LA5134	-	-	16	-	-	-																																																																																																																																																																																																																																																																																																																																																																																								
1LA5163	15	19	20	12	-	-																																																																																																																																																																																																																																																																																																																																																																																								
1LA5164	15	-	-	-	-	-																																																																																																																																																																																																																																																																																																																																																																																								
1LA5166	15	19	20	14	-	-																																																																																																																																																																																																																																																																																																																																																																																								
1LA5183	25	30	-	-	-	-																																																																																																																																																																																																																																																																																																																																																																																								
1LA5186	-	30	40	45	-	-																																																																																																																																																																																																																																																																																																																																																																																								
1LA5206	30	-	45	-	-	-																																																																																																																																																																																																																																																																																																																																																																																								
1LA5207	30	35	45	50	-	-																																																																																																																																																																																																																																																																																																																																																																																								
1LA6220	-	40	-	55	-	-																																																																																																																																																																																																																																																																																																																																																																																								
1LA6223	35	40	50	55	-	-																																																																																																																																																																																																																																																																																																																																																																																								
1LA6253	40	45	50	60	-	-																																																																																																																																																																																																																																																																																																																																																																																								
1LA6280	40	50	55	65	-	-																																																																																																																																																																																																																																																																																																																																																																																								
1LA6283	40	50	55	65	-	-																																																																																																																																																																																																																																																																																																																																																																																								
1LA6310	45	55	60	75	-	-																																																																																																																																																																																																																																																																																																																																																																																								
1LA6313	-	55	60	75	-	-																																																																																																																																																																																																																																																																																																																																																																																								
1LA831.	35	40	45	45	50	50																																																																																																																																																																																																																																																																																																																																																																																								
1LA835.	40	45	50	50	55	55																																																																																																																																																																																																																																																																																																																																																																																								
1LA840.	45	50	55	55	60	60																																																																																																																																																																																																																																																																																																																																																																																								
1LA845.	55	55	60	60	70	70																																																																																																																																																																																																																																																																																																																																																																																								
1LL831.	25	25	30	30	35	35																																																																																																																																																																																																																																																																																																																																																																																								
1LL835.	30	30	35	35	40	40																																																																																																																																																																																																																																																																																																																																																																																								
1LL840.	35	35	35	35	40	40																																																																																																																																																																																																																																																																																																																																																																																								
1LL845.	40	35	40	40	45	45																																																																																																																																																																																																																																																																																																																																																																																								
1LA135.	30	35	40	-	-	-																																																																																																																																																																																																																																																																																																																																																																																								
1LA140.	35	40	45	45	-	-																																																																																																																																																																																																																																																																																																																																																																																								
1LA145.	40	45	50	50	55	55																																																																																																																																																																																																																																																																																																																																																																																								
1LA150.	50	50	55	55	65	65																																																																																																																																																																																																																																																																																																																																																																																								
1LA156.	60	55	60	60	70	70																																																																																																																																																																																																																																																																																																																																																																																								
1LL135.	20	20	25	-	-	-																																																																																																																																																																																																																																																																																																																																																																																								
1LL140.	25	25	30	30	-	-																																																																																																																																																																																																																																																																																																																																																																																								
1LL145.	30	30	30	30	35	35																																																																																																																																																																																																																																																																																																																																																																																								
1LL150.	35	30	35	35	40	40																																																																																																																																																																																																																																																																																																																																																																																								
1LL156.	40	35	35	35	40	40																																																																																																																																																																																																																																																																																																																																																																																								
Type n _n =	3000	2000	1500	1000	500	1/min																																																																																																																																																																																																																																																																																																																																																																																								
1PH610.	25	25	25	20	-	-																																																																																																																																																																																																																																																																																																																																																																																								
1PH613.	30	30	30	30	-	-																																																																																																																																																																																																																																																																																																																																																																																								
1PH616.	-	35	35	35	-	-																																																																																																																																																																																																																																																																																																																																																																																								
1PH618.	40	40	40	40	40	-																																																																																																																																																																																																																																																																																																																																																																																								
1PH620.	40	40	40	40	40	-																																																																																																																																																																																																																																																																																																																																																																																								
1PH622.	40	40	40	40	40	-																																																																																																																																																																																																																																																																																																																																																																																								
	MDS(4) Parameter Type=O2; PKW: 1HEX=1.0s PcD Gr.: 0																																																																																																																																																																																																																																																																																																																																																																																													

PNU	Parameter Name in OP1	Range [Unit]	# of. Indices	read: / write: /
*:conf-P	Description	Value texts	Factory Settings.	
P364 * 16CHex	<p>Mot Load Limits</p> <p>Messages of the duty cycle monitor for the motor (in % of rated motor power)</p> <p>The parameter is valid for all motor data sets.</p> <p>Index i001 = WARN: When the entered load value is reached a warning message is edited via P625.</p> <p>Index i002 = FLT: When the entered load value is reached a fault message is edited via P626.</p> <p>Description for Setting: 0: no evaluation</p> <p>Related display parameter: r008 (Motor loading)</p> <p>Type=O2; PKW: 1HEX=1.0% PcD Gr.: 0</p>	0 to 300 [%]	2 i001=100 i002=100	2 / BR 2 / BR
P366 16EHex	<p>Auto Restart</p> <p>Auto restart after power outage</p> <p>Parameter values:</p> <p>0 = blocked</p> <p>1 = only power outage fault reset after power return (-> status Ready for turn-ON)</p> <p>2 = When power returns the drive turns on again after the wait time (P367)</p> <p>3 = Immediately after power return the drive turns on and performs the function 'Flying Restart'.</p> <p>Note: independently of the status of the bit 'release of Flying Restart' of the control word the 'Flying Restart' function is active at every turn ON if P366 = 3.</p> <p>Condition: P100 = 0, 1 (motor type = IEC, NEMA)</p> <p>ATTENTION: it must be guaranteed by external safety means that the drive can not start without intention at parameter settings P366 = 2, 3</p> <p>MDS(4) Parameter</p> <p>Type=O2; PKW: 1HEX=1.0 PcD Gr.: -</p>	0 to 3 none Flt Reset Auto Start Fly Auto St	4 i001=0 i002=0 i003=0 i004=0	2 / BR 2 / BR
P367 16FHex	<p>AutoRestart Wait</p> <p>Wait time between return of power and automatic drive restart if auto restart is on (P366 = 2).</p> <p>Note: The wait time is not valid if the Flying Restart function is active: (P366 = 3 (auto restart with flying restart), P583 (source for release of flying restart) or if bit 'Flying Restart' of the control word is set).</p> <p>Description for setting: the wait time should be in the range of the coasting time of the drive system.</p> <p>MDS(4) Parameter</p> <p>Type=O2; PKW: 1HEX=1.0s PcD Gr.: 0</p>	0 to 650 [s]	4 i001=0 i002=0 i003=0 i004=0	2 / BR 2 / BR
P369 171Hex	<p>Fly Search Amps</p> <p>Search current used for flying restart if no tachometer is used in % of rated motor current (P102)</p> <p>Conditions: P163 = 1, 3 (V/Hz modes, f control)</p> <p>Flying restart function must be released by the control bit (source see P583) or flying restart function must be released via P366 = 3 (auto restart)</p> <p>P100 = 0, 1 (motor type = IEC, NEMA)</p> <p>Setting instructions: For P163 = 3 (frequency control), a maximum of 200% of the rated magnetizing current (r196) is impressed.</p> <p>MDS(4) Parameter</p> <p>Type=O2; PKW: 1HEX=1.0% PcD: 4000HEX=400%</p>	10 to 400 [%]	4 i001=50 i002=50 i003=50 i004=50	2 / BR 2 / BR

PNU	Parameter Name in OP1	Range [Unit]	# of. Indices	read: write:
*:conf-P	Description	Value texts	Factory Settings.	/ /
P370 172Hex	Fly Search Speed Search speed Frequency range which is to be passed during flying restart within 1 sec. Conditions: as for P369 P100 = 0, 1 (motor type = IEC, NEMA) MDS(4) Parameter Type=O2; PKW: 1HEX=0.1Hz PcD: 4000HEX=163.84Hz	0.1 to 100.0 [Hz]	4 i001=1.0 i002=1.0 i003=1.0 i004=1.0	2/ BR 2/ BR
P371 173Hex	De-magnetizeTime De-excitation time of the motor Minimum wait time between pulse blocking and pulse release. The induction motor de-magnetizes during this period. Pre-set during automatic parameterization (P052 = 6, 7). Description for setting: About 2.3*rotor time constant (r200), but not more than 3.0s. This setting guarantees that the motor is de-magnetized for at least 90% when pulses are released. ATTENTION: After OFF1, OFF3 and JOG commands the de-excitation time is not active MDS(4) Parameter Type=O2; PKW: 1HEX=0.01s PcD Gr.: 0	0.01 to 10.00 [s]	4 i001=1.00 i002=1.00 i003=1.00 i004=1.00	2/ BR 2/ BR
P372 174Hex	DC Braking DC injection braking of the motor to brake a DC motor without optional braking equipment (chopper, regenerative front end) ATTENTION: All loss energy concentrates in the motor, the danger of a local overheating in the motor exists! Note: Only for induction motors Overcurrent interventions (alarm A02) can occur for overdimensioned motors (P102 > P072) when starting the DC brake. In this case, the de-energization time (P371) must be increased. Parameter values: 0: DC injection braking OFF 1: DC injection braking active with OFF3 command ('quick stop'). Condition: P100 = 0, 1 (motor type = IEC, NEMA) MDS(4) Parameter Type=O2; PKW: 1HEX=1.0 PcD Gr.: -	0 to 1 off on	4 i001=0 i002=0 i003=0 i004=0	2/ BR 2/ BR
P373 175Hex	DC Braking Amps Setpoint for the DC injection braking current in % of rated motor current Condition: P372 = 1 (DC injection braking) MDS(4) Parameter Type=O2; PKW: 1HEX=1.0% PcD: 4000HEX=400%	20 to 400 [%]	4 i001=100 i002=100 i003=100 i004=100	2/ BR 2/ BR
P374 176Hex	DC Braking Time DC injection braking time Condition: P372 = 1 (DC injection braking) MDS(4) Parameter Type=O2; PKW: 1HEX=0.1s PcD: 4000HEX=163.84s	0.1 to 99.9 [s]	4 i001=5.0 i002=5.0 i003=5.0 i004=5.0	2/ BR 2/ BR
P375 177Hex	DC Braking Freq Start frequency for DC injection braking; if OFF3 command is active DC injection braking is performed below this frequency Condition: P372 = 1 (DC injection braking) MDS(4) Parameter Type=O2; PKW: 1HEX=0.1Hz PcD: 4000HEX=163.84Hz	0.1 to 600.0 [Hz]	4 i001=300.0 i002=300.0 i003=300.0 i004=300.0	2/ BR 2/ BR

PNU	Parameter Name in OP1	Range [Unit]	# of. Indices	read: write:
*:conf-P	Description	Value texts	Factory Settings.	
P380 17CHex	PRT/FLR LowVolts Point at which the PRT control or the FLR is activated. DC link voltage which when fallen below, the PRT or FLR is activated (reference quantity: rated DC link voltage; for AC drive converters P071*1.32, for DC converters, P071). Condition: P379 = 1 (select PRT) or P379 = 2, 3 (select FLR) MDS(4) Parameter Type=O2; PKW: 1HEX=1.0% PcD Gr.: -	65 to 92 [%]	4 i001=76 i002=76 i003=76 i004=76	3/ BR 3/ BR
P381 17DHex	PRT/FLR Reg Dyn Controller dynamic behavior for kinetic buffering (P379 = 1) for all control types and flexible response (P379 = 2, V/f = const.) for V/f characteristic (P163 = 0, 1, 2). A parameter value of 0% turns OFF the function. Condition: P379 = 1 (select PRT) or P379 = 2 (select FLR, V/f = const.) and P163 = 0, 1, 2 MDS(4) Parameter Type=O2; PKW: 1HEX=1.0% PcD Gr.: -	0 to 200 [%]	4 i001=50 i002=50 i003=50 i004=50	3/ BR 3/ BR
r385 181Hex	f(PRT/VdmaxReg) Output signal of the Vdmax / PRT controller; this frequency is added to the frequency setpoint (r482). Condition: P163 = 0, 1, 2 (V/Hz modes) Analog Output: 100% @ Parameter Value=P420 Type=l2; PKW: 1HEX=0.01Hz PcD Gr.: 1	[Hz]	-	3/ BR
r386 182Hex	I(PRT/VdmaxReg) Output signal of the Vdmax / PRT controller; this current is added to the torque generating current component (r246). Condition: P163 = 3, 4, 5 (Vector control modes); Analog Output: 100% @ Parameter Value=4*P102 Type=l2; PKW: 1HEX=0.1A PcD Gr.: 2	[A]	-	3/ BR
P387 183Hex	FLR Vd min Minimum DC link bus voltage in % of the rated DC link bus voltage (for AC drives: P071 * 1.32, for DC inverters: P071); lower voltages trip the inverter and an DC link bus undervoltage fault. Condition: P379 = 2, 3 (FLR released) MDS(4) Parameter Type=O2; PKW: 1HEX=1.0% PcD Gr.: -	50 to 76 [%]	4 i001=76 i002=76 i003=76 i004=76	3/ BR 3/ B
r388 184Hex	Sync Status Monitoring of the synchronization process: Parameter values: 0 = synchronization OFF 1 = frequency measurement active 2 = phase control active 3 = synchronized 4 = synchronization failure Condition: P090 = 4 or P091 = 4 (TSY board in position 2 or 3 of the electronic box) P163 = 2 (V/Hz mode for textile applications) Type=O2; PKW: 1HEX=1.0 PcD Gr.: 0	not active f Evaluat Phi Regulat Synchron´d sync.-fail.	-	3/ BR

PNU	Parameter Name in OP1	Range [Unit]	# of. Indices	read: <input type="checkbox"/> write: <input type="checkbox"/>
*:conf-P	Description	Value texts	Factory Settings.	
P389 * 185Hex	SyncStartDelta f maximum allowed frequency deviation for starting the synchronization process. Synchronization will not start before target frequency- frequency of the synchronization drive < P389. Note: Upper limit is defined by the limit for the synchronization controller (P392) Dependent parameter: P582 (Source Sync. release) P392 (Sync. fmax) Condition: P090 = 4 or P091 = 4 (TSY board in position 2 or 3 of the electronic box) P163 = 2 (V/Hz mode for textile applications) Type=l4; PKW: 1HEX=0.01Hz PcD Gr.: 1	0.00 to 1.00 [Hz]	- 0.10	3 / BR 3 / BR
P390 * 186Hex	Sync Angle(set) Phase angle deviation setpoint for the synchronization. Phase angle between the synchronization signal and the synchronizing drive; a negative parameter value means, that the voltage system of the synchronizing drive is delayed against the measured signal. Example: • A drive is to be synchronized to phase R of a voltage system • A measured synchronization signal derives from the delta-voltage V_{R-s} -> P390 is set to -30° (drive compares its own voltage V_R with the measured signal V_{R-s} , which has a phase shift of 30° electr. Dependent parameter: P582 (Source synchronization release) Related display parameter: r394 (Sync. phase angle difference) Condition: P090 = 4 or P091 = 4 (TSY board in position 2 or 3 of the electronic box) P163 = 2 (V/Hz mode for textile applications) Type=l2; PKW: 1HEX=0.1°el PcD: 4000HEX=90°el	-180.0 to 179.9 [°el]	- 0.0	3 / BR 3 / BR
P391 * 187Hex	Sync Window Deviation for the synchronization fault message The parameter defines the phase angle deviation which generates a synchronization fault message after synchronization of the frequency. If the tolerance range is exceeded, a formerly issued synchronization command will not be withdrawn, only a warning message and the synchronization fault message (P630) will be issued. Warning, synchronization fault message and the synchronization command will only be withdrawn by canceling the synchronization command (P582) or by an OFF command. Condition: P090 = 4 or P091 = 4 (TSY board in position 2 or 3 of the electronic box) P163 = 2 (V/Hz mode for textile applications) Type=l2; PKW: 1HEX=0.1°el PcD: 4000HEX=90°el	1.0 to 20.0 [°el]	- 2.0	3 / BR 3 / BR
P392 * 188Hex	Sync f-max Maximum operating range of the synchronization controller. The output signal of the synchronization controller is limited to this frequency. During synchronization a frequency step of maximum the entered value is possible. The lower value of the setting range is limited by the value of the frequency deviation at the beginning of the synchronization (P389). Condition: P090 = 4 or P091 = 4 (TSY board in position 2 or 3 of the electronic box) P163 = 2 (V/Hz mode for textile applications) Type=l4; PKW: 1HEX=0.01Hz PcD Gr.: 1	0.00 to 1.00 [Hz]	- 0.20	3 / BR 3 / BR

PNU	Parameter Name in OP1	Range [Unit]	# of. Indices	read: write:
*:conf-P	Description	Value texts	Factory Settings.	/ /
r393 189Hex	<p>Sync Target Freq</p> <p>Measured target frequency during synchronization</p> <p>Maximum value which can be displayed: 8 times rated motor frequency (P107).</p> <p>Condition: P090 = 4 or P091 = 4 (TSY board in position 2 or 3 of the electronic box) P163 = 2 (V/Hz mode for textile applications)</p> <p>Analog Output: 100% @ Parameter Value=P420</p> <p>Type=I4; PKW: 1HEX=0.01Hz PcD Gr.: 1</p>	[Hz]	-	3/ BR
r394 18AHex	<p>Sync Phase Diff</p> <p>Actual phase angle difference between phase U of the synchronizing drive and the measured synchronization signal of the target voltage system.</p> <p>Note: at P388 = 0, 1 the setpoint angle P390 - 180° el is displayed.</p> <p>Conditions: P090 = 4 or P091 = 4 (TSY board in position 2 or 3 of the electronic box) P163 = 2 (V/Hz mode for textile applications)</p> <p>Analog Output: 100% @ Parameter Value=90.0°el</p> <p>Type=I2; PKW: 1HEX=0.1°el PcD: 4000HEX=90°el</p>	[°el]	-	3/ BR
P395 18BHex	<p>Selectivity</p> <p>In configurations, where one drive is feeding a number of paralleled motors in the case of a failure (short circuit, ground fault, motor blocked) one of these motors may be disconnected from the drive by blowing its fuses.</p> <p>ATTENTION: If the selectivity function is selected, there is no protection available against a terminal short circuit; the overcurrent protection is still active.</p> <p>Parameter values: 0: Selectivity OFF 1: Selectivity ON</p> <p>Type=O2; PKW: 1HEX=1.0 PcD Gr.: -</p>	0 to 1 OFF ON	- 0	3/ BR 3/ B

11.8 Setpoint Channel

PNU *:conf-P	Parameter Name in OP1 Description	Range [Unit] Value texts	# of. Indices Factory Settings.	read: / write: /
r410 19AHex	act. SetpDataSet Active setpoint channel data set Parameter values: 0 = setpoint data set 1 1 = setpoint data set 2 2 = setpoint data set 3 3 = setpoint data set 4 Analog Output: 100% @ Parameter Value=16384 Type=O2; PKW: 1HEX=1.0 PcD Gr.: 0	SDS 1 SDS 2 SDS 3 SDS 4	-	3 / BR
P420 1A4Hex	System Rtd Freq Rated system frequency / speed Reference quantity for acceleration time (P462), deceleration time (P464), hysteresis for 'ramp generator active' message (P476), base setpoint (P445) and for speed / frequency setpoint and actual values which are transferred via analog inputs and outputs or serial communications. Type=I4; PKW: 1HEX=0.01Hz PcD Gr.: 1	1.00 to 600.00 [Hz]	- 50.00	2 / ABR 2 / AB
P421 1A5Hex	Fixed Freq1(set) By setting the correlated bits of the control word (r551) the fixed setpoint is activated from the source defined in P580 / P581. SDS(4) Parameter Type=I4; PKW: 1HEX=0.001Hz PcD Gr.: 1	-600.000 to 600.000 [Hz]	4 i001=50.000 i002=50.000 i003=50.000 i004=50.000	2 / BR 2 / BR
P422 1A6Hex	Fixed Freq2(set) By setting the correlated bits of the control word (r551) the fixed setpoint is activated from the source defined in P580 / P581. SDS(4) Parameter Type=I4; PKW: 1HEX=0.001Hz PcD Gr.: 1	-600.000 to 600.000 [Hz]	4 i001=-50.000 i002=-50.000 i003=-50.000 i004=-50.000	2 / BR 2 / BR
P423 1A7Hex	Fixed Freq3(set) By setting the correlated bits of the control word (r551) the fixed setpoint is activated from the source defined in P580 / P581. SDS(4) Parameter Type=I4; PKW: 1HEX=0.001Hz PcD Gr.: 1	-600.000 to 600.000 [Hz]	4 i001=20.000 i002=20.000 i003=20.000 i004=20.000	2 / BR 2 / BR
P424 1A8Hex	Fixed Freq4(set) By setting the correlated bits of the control word (r551) the fixed setpoint is activated from the source defined in P580 / P581. SDS(4) Parameter Type=I4; PKW: 1HEX=0.001Hz PcD Gr.: 1	-600.000 to 600.000 [Hz]	4 i001=5.000 i002=5.000 i003=5.000 i004=5.000	2 / BR 2 / BR
P425 1A9Hex	MOP saving Saving of the setpoint which has come from the motor operated potentiometer (MOP) at turn OFF / power outage The saved setpoint signal is active again after a new ON command (P443 = 1002, main setpoint from MOP). If saving of the MOP setpoint is not active (P425 = 0, 2), the MOP start frequency (P426) is cleared after an OFF command or a power outage. The „internal motorized potentiometer rounding-off“ (necessary to precisely set a frequency) can be cancelled if the motorized potentiometer (MOP) is to ramp-up extremely quickly. Parameter values: 0: without save with 'internal MOP rounding-off' 1: with save with 'internal MOP rounding-off' 2: without save without 'internal MOP rounding-off' 3: with save without 'internal MOP rounding-off' Type=O2; PKW: 1HEX=1.0 PcD Gr.: -	0 to 3 OFF ON OFF ON	- 0	2 / BR 2 / BR

PNU	Parameter Name in OP1	Range [Unit]	# of. Indices	read: write:
*:conf-P	Description	Value texts	Factory Settings.	/ /
P426 1AAHex	MOP start frequ Start frequency of the motor operated potentiometer (MOP) The motorized potentiometer setpoint is set to this start frequency if storage is not active (P425 = 0, 2), in the drive converter statuses, switch-on inhibit (r001 = °008), and ready to power-up (r001 = °009). As the motorized potentiometer setpoint can only have positive values, the sign must be specified via the direction of rotation bits (P571, P572). SDS(4) parameter Type=l4; PKW: 1HEX=0.001Hz PcD Gr.: 1	0.000 to 600.000 [Hz]	4 i001=0.000 i002=0.000 i003=0.000 i004=0.000	3 / BR 3 / BR
P427 1ABHex	Set MOP The motorized potentiometer is set to the absolute value of the main setpoint. The motorized potentiometer setpoint is set to the absolute value of the main setpoint (r447) when changing-over the main setpoint source to a motorized potentiometer (P443 = 1002; e.g. for basic/reserved changeover). Thus, a continuous transition can be achieved when changing-over from automatic- to manual operation. As the motorized potentiometer setpoint can only be positive, the sign must be specified via the direction of rotation bits (P571, P572). Parameter values: 0: no storage 1: with storage Type=l2; PKW: 1HEX = 0.01 Hz PcD Gr.:1	0 to 1 OFF ON	- 0	2 / BR 2 / BR
P433 * 1B1Hex	Src AddSetpoint1 Source of the additional setpoint signal 1 (in front of the ramp generator) Parameter values: 1001: Fixed setpoints (P421 to P424) other values: according to the process data wiring of the setpoint channel data set. B/R Parameter Type=L2; PKW: PKW-Format(HEX)=Par Value PcD Gr.: 0	0 to 6045	2 i001=0 i002=0	3 / BR 3 / BR
P434 1B2Hex	GainAddSetpoint1 Proportional gain of the additional setpoint signal 1 Not effective if the additional setpoint is a fixed setpoint (P433 = 1001). B/R Parameter Type=l2; PKW: 1HEX=0.01% PcD Gr.: 0	-300.00 to 300.00 [%]	2 i001=100.00 i002=100.00	3 / BR 3 / BR
r437 1B5Hex	Add Setpoint 1 Actual additional setpoint 1 (in front of the ramp generator) Analog Output: 100% @ Parameter Value=P420 Type=l4; PKW: 1HEX=0.001Hz PcD Gr.: 1	[Hz]	-	3 / BR
P438 * 1B6Hex	Src AddSetpoint2 Source of the additional setpoint signal 2 (behind the ramp generator) Parameter values: 1001: Fixed setpoints (P421 to P424) other values: according to the process data wiring of the setpoint channel data set. B/R Parameter Type=L2; PKW: PKW-Format(HEX)=Par Value PcD Gr.: 0	0 to 6045	2 i001=0 i002=0	3 / BR 3 / BR
P439 1B7Hex	GainAddSetpoint2 Proportional gain of the additional setpoint signal 2 Not effective if the additional setpoint is a fixed setpoint (P438 = 1001). B/R Parameter Type=l2; PKW: 1HEX=0.01% PcD Gr.: 0	-300.00 to 300.00 [%]	2 i001=100.00 i002=100.00	3 / BR 3 / BR

PNU	Parameter Name in OP1	Range [Unit]	# of Indices	read: / write: /
*:conf-P	Description	Value texts	Factory Settings.	
r442 1BAHex	Add Setpoint 2 Actual additional setpoint 2 (behind the ramp generator) Analog Output: 100% @ Parameter Value=P420 Type=I4; PKW: 1HEX=0.001Hz PcD Gr.: 1	[Hz]	-	3 / BR
P443 * 1BBHex	Src MainSetpoint Source of the (frequency / speed) main setpoint signal. Parameter values: 1002: Motor operated potentiometer (MOP) other values: according to the process data wiring of the setpoint channel data set. B/R Parameter Type=L2; PKW: PKW-Format(HEX)=Par Value PcD Gr.: 0	0 to 6045	2 i001=1002 i002=1001	2 / BR 2 / BR
P444 1BCHex	GainMainSetpoint Proportional gain of the main setpoint signal Not effective if the setpoint is a fixed setpoint or comes from the MOP (P443 = 1001, 1002). B/R Parameter Type=L2; PKW: 1HEX=0.01% PcD Gr.: 0	-300.00 to 300.00 [%]	2 i001=100.00 i002=100.00	2 / BR 2 / BR
P445 1BDHex	Base Setpoint Base setpoint of the main setpoint channel in % of rated system frequency (P420); is added to the main setpoint signal. Not effective if the setpoint is a fixed setpoint or comes from the MOP (P443 =1001, 1002). B/R Parameter Type=L2; PKW: 1HEX=0.1% PcD Gr.: 0	-100.0 to 100.0 [%]	2 i001=0.0 i002=0.0	3 / BR 3 / BR
r447 1BFHex	Main Setp.(act) Actual main setpoint Analog Output: 100% @ Parameter Value=P420 Type=I4; PKW: 1HEX=0.001Hz PcD Gr.: 1	[Hz]	-	2 / BR
P448 1C0Hex	Jog Frequency 1 Jog frequency 1 Type=I4; PKW: 1HEX=0.001Hz PcD Gr.: 1	-600.000 to 600.000 [Hz]	- 5.000	2 / BR 2 / BR
P449 1C1Hex	Jog Frequency 2 Jog frequency 2 Type=I4; PKW: 1HEX=0.001Hz PcD Gr.: 1	-600.000 to 600.000 [Hz]	- 10.000	2 / BR 2 / BR
r451 1C3Hex	n/f(set,total1) Frequency setpoint signal at the addition point in front of the ramp generator Analog Output: 100% @ Parameter Value=P420 Type=I4; PKW: 1HEX=0.001Hz PcD Gr.: 1	[Hz]	-	3 / BR
P452 1C4Hex	Max Freq FWD Maximum frequency at forward speed Limited by: <ul style="list-style-type: none"> double rated motor frequency at P163 = 0, 1, 2 (V/Hz modes) 5 times rated motor frequency at P163 = 3, 4, 5 (Vector control modes) Pulse frequency MDS(4) Parameter Type=I4; PKW: 1HEX=0.1Hz PcD Gr.: 1	0.0 to 600.0 [Hz]	4 i001=55.0 i002=55.0 i003=55.0 i004=55.0	2 / ABR 2 / AB

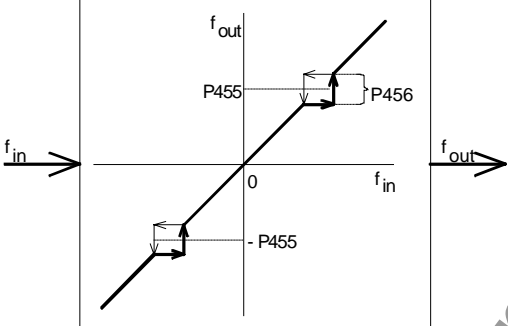
PNU	Parameter Name in OP1	Range [Unit]	# of. Indices	read: write:
*:conf-P	Description	Value texts	Factory Settings.	/ /
P453 1C5Hex	Max Freq REV Maximum frequency at reverse speed Limited by: <ul style="list-style-type: none"> double rated motor frequency at P163 = 0, 1, 2 (V/Hz modes) 5 times rated motor frequency at P163 = 3, 4, 5 (Vector control modes) Pulse frequency MDS(4) Parameter Type=I4; PKW: 1HEX=0.1Hz PcD Gr.: 1	-600.0 to 0.0 [Hz]	4 i001=-55.0 i002=-55.0 i003=-55.0 i004=-55.0	2 / ABR 2 / AB
P455 1C7Hex	Skip Frequency Skip frequency for the frequency setpoint in front of the ramp generator. Steady state operation is not possible in the range of the positive and the negative value of the skip frequency.  <p>Note: Frequency skipping is OFF at parameter values between 0.0 Hz and 0.5*P456</p> SDS(4) Parameter Type=I4; PKW: 1HEX=0.1Hz PcD Gr.: 1	0.0 to 600.0 [Hz]	4 i001=0.0 i002=0.0 i003=0.0 i004=0.0	2 / BR 2 / BR
P456 1C8Hex	Skip Freq Width Width of the skip frequency band in the setpoint channel; see P455 SDS(2) Parameter Type=I4; PKW: 1HEX=0.1Hz PcD Gr.: 1	0.0 to 600.0 [Hz]	4 i001=2.0 i002=2.0 i003=2.0 i004=2.0	2 / BR 2 / BR
P457 1C9Hex	Min Frequency Minimum frequency f_{min} (amount) of the drive; same as frequency skipping around 0 Hz with a bandwidth of $2 * f_{min}$, effective for the setpoint signal in front of the ramp generator Given setpoint f_{set} : <ul style="list-style-type: none"> $-f_{min} < f_{set}$ (coming from lower values) $< f_{min}$ $-f_{min} < f_{set}$ (coming from higher values) $< f_{min}$ $0 \leq f_{set}$ (after turn ON) $< f_{min}$ $-f_{min} < f_{set}$ (after turn ON) < 0 $f_{set} > f_{min}$ $f_{set} < -f_{min}$ realized setpoint <ul style="list-style-type: none"> - f_{min} + f_{min} + f_{min} - f_{min} f_{set} f_{set} Note: The bits for forward / reverse operation (see P571, P572) are allowed for. SDS(4) Parameter Type=I4; PKW: 1HEX=0.1Hz PcD Gr.: 1	-600.0 to 600.0 [Hz]	4 i001=0.0 i002=0.0 i003=0.0 i004=0.0	2 / BR 2 / BR
r460 1CCHex	n/f(set,Ramp IN) Frequency setpoint signal at ramp generator input Analog Output: 100% @ Parameter Value=P420 Type=I4; PKW: 1HEX=0.001Hz PcD Gr.: 1	[Hz]	-	3 / BR

PNU	Parameter Name in OP1	Range [Unit]	# of. Indices	read: <input type="checkbox"/> write: <input type="checkbox"/>
*:conf-P	Description	Value texts	Factory Settings.	
r461 1CDHex	<p>Ramp Gen Status Status of the ramp generator</p> <p>Parameter values: 0: ramp generator blocked 1: ramp generator released 2: ramp generator stopped 4: ramp generator set 5: ramp generator following</p> <p>Analog Output: 100% @ Parameter Value=16384 Type=O2; PKW: 1HEX=1.0 PcD Gr.: 0</p>	Locked Released STOP Set Following	-	3 / BR
P462 1CEHex	<p>Accel. Time Ramp generator acceleration time for acceleration from 0 to rated system frequency (P420).</p> <p>Unit : as defined in P463 (acceleration time unit).</p> <p>Note: during motor data identification (P052 = 8, 10) this value is only increased if the set acceleration time is too low and the unit (P463, P465) for both acceleration and deceleration times is in seconds (the drive can not realize the acceleration time because of the torque limit).</p> <p>SDS(4) Parameter Type=O2; PKW: 1HEX=0.1 PcD Gr.: 0</p>	0.0 to 999.9	4 i001=10.0 i002=20.0 i003=30.0 i004=40.0	2 / ABR 2 / ABR
P463 1CFHex	<p>Accel. Time Unit Unit of the ramp generator acceleration time</p> <p>Parameter values: 0: Seconds 1: Minutes 2: Hours</p> <p>SDS(4) Parameter Type=O2; PKW: 1HEX=1.0 PcD Gr.: -</p>	0 to 2 Sec Min Hours	4 i001=0 i002=0 i003=0 i004=0	2 / ABR 2 / ABR
P464 1D0Hex	<p>Decel. Time Ramp generator deceleration time for deceleration from rated system frequency (P420) to standstill</p> <p>Unit: as defined in P465 (deceleration time unit).</p> <p>Note: During motor data identification (P052 = 8, 10) this value is only increased if the set acceleration time is too low and the unit (P463, P465) for both acceleration and deceleration times is in seconds (the drive can not realize the acceleration time because of the torque limit).</p> <p>SDS(4) Parameter Type=O2; PKW: 1HEX=0.1 PcD Gr.: 0</p>	0.0 to 999.9	4 i001=20.0 i002=20.0 i003=20.0 i004=20.0	2 / ABR 2 / ABR
P465 1D1Hex	<p>Decel. Time Unit Unit of the ramp generator deceleration time</p> <p>Parameter values: 0: Seconds 1: Minutes 2: Hours</p> <p>SDS(4) Parameter Type=O2; PKW: 1HEX=1.0 PcD Gr.: -</p>	0 to 2 Sec Min Hours	4 i001=0 i002=0 i003=0 i004=0	2 / ABR 2 / ABR

PNU	Parameter Name in OP1	Range [Unit]	# of. Indices	read: write:
*:conf-P	Description	Value texts	Factory Settings.	/ /
P466 1D2Hex	<p>Decel. Time OFF3</p> <p>OFF3 deceleration time (quick stop) for deceleration from rated system frequency (P420) to standstill</p> <p>Note: Rounding (P468) is not active during OFF3.</p> <p>Description for setting:</p> <ul style="list-style-type: none"> The parameter value must be high enough to prevent an overvoltage fault. For P163 = 0, 1, 2, 3 (V/f characteristic, f control), the drive could trip if the deceleration time is too low. For P163 = 3, 4, 5 (vector control types), if deceleration is not realized along the torque limit for OFF3, then P466 can be reduced. <p>Type=O2; PKW: 1HEX=0.1s PcD Gr.: 0</p>	0.0 to 999.9 [s]	- 1.0	2/ BR 2/ BR
P467 1D3Hex	<p>ProtRampGen Gain</p> <p>Protective ramp generator: factor, which extends the acceleration time (P462).</p> <p>For P163 = 0, 1, 2 (V/Hz modes):</p> <p>The protective ramp generator is active up to 15 % of rated motor frequency (P107); see section „Ramp-function generator RFG“ in the Instruction Manual, Part 2</p> <p>For P163 = 3 (Frequency control)</p> <p>The protection ramp generator is active up to 1.1 * P284 (change to counter EMF model). As long as the current model is active, the acceleration is also influenced by the current settings (P202, P203, P204).</p> <p>If permanent-magnet synchronous motors are being controlled (P100 = 3), the protective ramp-function generator should be set (>= 5), so that the drive does not stall when accelerating.</p> <p>Further, at least 20 % must be entered in P202.</p> <p>For P163 = 4, 5 (Speed / torque control)</p> <p>The protection ramp generator is not active.</p> <p>The protection ramp generator is only active, if the unit of the acceleration time (P463) is sec.</p> <p>During motor data identification (P052 = 8, 10) this value is only increased if the set acceleration time is too low and the unit (P463, P465) for both acceleration and deceleration times is in seconds.</p> <p>Description for setting: Parameter value 1.0 turns OFF the protective ramp generator.</p> <p>Condition: P163 = 0, 1, 2, 3 (V/Hz modes, f control)</p> <p>SDS(4) Parameter</p> <p>Type=O2; PKW: 1HEX=0.1 PcD Gr.: 0</p>	1.0 to 100.0	4 i001=1.0 i002=1.0 i003=1.0 i004=1.0	3/ BR 3/ BR
P469 1D5Hex	<p>Ramp StartSmooth</p> <p>Start rounding of the ramp generator in % of the acceleration (P462) and deceleration times (P464).</p> <p>At accelerating from 0 to rated system frequency (P420) the real acceleration time will increase to $P462 \cdot \left(1 + \frac{P469}{100\%} + \frac{P470}{100\%}\right)$.</p> <p>Condition: P463 = 0, P465 = 0 (acceleration and deceleration times in seconds)</p> <p>SDS(4) Parameter</p> <p>Type=O2; PKW: 1HEX=1.0% PcD Gr.: -</p>	0 to 50 [%]	4 i001=10 i002=10 i003=10 i004=10	2/ BR 2/ BR

PNU	Parameter Name in OP1	Range [Unit]	# of. Indices	read: $\frac{1}{1}$ write: $\frac{1}{1}$
*:conf-P	Description	Value texts	Factory Settings.	
P470 1D6Hex	<p>Ramp End Smooth</p> <p>End rounding of the ramp generator in % of the acceleration (P462) and deceleration times (P464).</p> <p>At accelerating from 0 to rated system frequency (P420) the real acceleration time will increase to $P462 \cdot \left(1 + \frac{P469}{100\%} + \frac{P470}{100\%}\right)$.</p> <p>Condition: P463 = 0, P465 = 0 (acceleration and deceleration times in seconds)</p> <p>SDS(4) Parameter Type=O2; PKW: 1HEX=1.0% PcD Gr.: -</p>	0 to 50 [%]	4 i001=10 i002=10 i003=10 i004=10	2 / BR 2 / BR
P475 1DBHex	<p>Ramp Limitation</p> <p>Ramp generator following function</p> <p>The frequency change rate of the ramp generator is adapted to the maximum possible acceleration of the drive.</p> <p>The parameter value refers to the frequency deviation at the input of the n/f controller which is needed to accelerate the drive at the torque limit.</p> <p>Description for Setting: At a value of 0.0 the ramp generator following function is OFF. The greater the parameter value is, the greater is the admitted deviation between n/f setpoint and the actual value.</p> <p>Condition: P163 = 4 (n control) Type=O2; PKW: 1HEX=0.1% PcD Gr.: 0</p>	0.0 to 50.0 [%]	0.0	3 / BR 3 / BR
P476 1DCHex	<p>RampGen Act Hyst</p> <p>Hysteresis for the message 'ramp generator active'</p> <p>The message 'ramp generator active' is issued, if $\text{ramp generator input} - \text{ramp generator output} \geq P476 \cdot P420$.</p> <p>Condition: analog frequency setpoint in front of the ramp generator (see P433 and P443) Type=O2; PKW: 1HEX=0.1% PcD Gr.: -</p>	0.0 to 20.0 [%]	- 1.0	3 / BR 3 / BR
r480 1E0Hex	<p>n/f(set,rampOUT)</p> <p>Frequency setpoint at the output of the ramp generator</p> <p>Analog Output: 100% @ Parameter Value=P420 Type=l4; PKW: 1HEX=0.001Hz PcD Gr.: 1</p>	[Hz]	-	3 / BR
r481 1E1Hex	<p>n/f(set,total2)</p> <p>Frequency setpoint at the addition point behind the ramp generator</p> <p>Analog Output: 100% @ Parameter Value=P420 Type=l4; PKW: 1HEX=0.001Hz PcD Gr.: 1</p>	[Hz]	-	3 / BR
r482 1E2Hex	<p>n/f(set)</p> <p>Frequency setpoint at the input of the V/Hz control circuit and n/f/T control circuit, respectively</p> <p>Analog Output: 100% @ Parameter Value=P420 Type=l4; PKW: 1HEX=0.001Hz PcD Gr.: 1</p>	[Hz]	-	2 / BR
P485 1E5Hex	<p>System RtdTorque</p> <p>Rated system torque in % of rated motor torque</p> <p>Scaling reference for torque setpoint signals which are entered via the admitted sources of the setpoint wiring (see process data wiring of the setpoint channel)</p> <p>This scaling is also valid for torque actual values which are issued via output channels (analog outputs, serial communications).</p> <p>Condition: P163 = 3, 4, 5 (Vector control modes) Type=O2; PKW: 1HEX=0.1% PcD: 4000HEX=400%</p>	0.1 to 800.0 [%]	- 100.0	3 / ABR 3 / AB

PNU	Parameter Name in OP1	Range [Unit]	# of. Indices	read: write:
*:conf-P	Description	Value texts	Factory Settings.	/ /
P486 * 1E6Hex	Src Torque Setp Source of the torque setpoint signal Parameter values: 1001: not allowed 1002: not allowed other values: see process data wiring of the setpoint channel. Condition: P163 = 3, 4, 5 (Vector control modes) At f/n control only effective, if the drive is operated as a slave drive (control word 2, Bit 27 = 1). B/R Parameter Type=L2; PKW: PKW-Format(HEX)=Par Value PcD Gr.: 0	0 to 6045	2 i001=0 i002=0	3/ BR 3/ BR
P487 1E7Hex	Torque Setp Gain Proportional gain for the torque setpoint Condition: P163 = 3, 4, 5 (Vector control modes) At f/n control only effective, if the drive is operated as a slave drive (control word 22, Bit 27 = 1). B/R Parameter Type=L2; PKW: 1HEX=0.01% PcD Gr.: 0	-300.00 to 300.00 [%]	2 i001=100.00 i002=100.00	3/ BR 3/ BR
r490 1EAHex	Torque Setpoint Actual torque setpoint Condition: P163 = 3, 4, 5 (Vector control modes) At f/n control only effective, if the drive is operated as a slave drive (control word 2, Bit 27 = 1). For closed-loop frequency control, in the range of the I model (r286=0), a torque setpoint less than 1% of the rated motor torque causes the drive to be braked. Analog Output: 100% @ Parameter Value=P485 Type=L2; PKW: 1HEX=0.1% PcD Gr.: 5	[%]	-	3/ BR
P492 1ECHex	FixTorque 1 Set Fixed upper limit of the torque setpoint in % of the rated motor torque. If drives without regenerative front end or braking chopper trip with overvoltage, the regenerative power (in reverse operation) must be limited via P233 and the Vdmax controller must be activated (P377). Note: P492 is also the upper torque limit during an external setpoint (P493 <> 1001) Condition: P163 = 3, 4, 5 (Vector control modes) SDS(4) Parameter Type=L2; PKW: 1HEX=0.1% PcD: 4000HEX=400%	-300.0 to 300.0 [%]	4 i001=100.0 i002=100.0 i003=100.0 i004=100.0	3/ BR 3/ BR
P493 * 1EDHex	Src FixTorque 1 Source of the upper torque limit. Parameter values: 1001: internal upper fixed torque limit (P492) 1002: not allowed other values: see process data wiring of the setpoint channel. Note: The torque limit can only be changed within the range specified by the upper limit for the torque setpoint (P492). Condition: P163 = 3, 4, 5 (Vector control modes) B/R Parameter Type=L2; PKW: PKW-Format(HEX)=Par Value PcD Gr.: 0	0 to 6045	2 i001=1001 i002=1001	3/ BR 3/ BR
P494 1EEHex	FixTorque 1 Gain Proportional gain of the upper torque limit; not effective for fixed setpoint (P493 = 1001). B/R Parameter Type=L2; PKW: 1HEX=0.01% PcD Gr.: 0	-300.00 to 300.00 [%]	2 i001=100.00 i002=100.00	3/ BR 3/ BR

PNU	Parameter Name in OP1	Range [Unit]	# of. Indices	read: <input type="checkbox"/> write: <input type="checkbox"/>
*:conf-P	Description	Value texts	Factory Settings.	
r496 1F0Hex	Fix Torque 1 Maximum value of the upper torque limit in % of rated motor torque Display parameter of the output of the upper torque limit (P493) Condition: P163 = 3, 4, 5 (Vector control modes) Analog Output: 100% @ Parameter Value=P485 Type=L2; PKW: 1HEX=0.1% PcD Gr.: 5	[%]	-	3 / BR
r497 1F1Hex	Max Torque 1 Real upper torque limit in % of rated motor torque; this parameter is identical with r496 except for torque control. Note: The value of this parameter may be reduced by the power limit (P223) or the current limit (P173). P235 displays the effective torque limit. Condition: P163 = 3, 4, 5 (Vector control modes) Analog Output: 100% @ Parameter Value=P485 Type=L2; PKW: 1HEX=0.1% PcD Gr.: 5	[%]	-	3 / BR
P498 1F2Hex	FixTorq 2 Set Fixed lower torque limit in % of the rated motor torque. If drives without regenerative front end or braking chopper trip with overvoltage, the regenerative power (in forward operation) must be limited via P233 and the Vdmax controller must be activated (P377). Note: P498 is also the lower torque limit during an external setpoint (P499 <> 1001) Condition: P163 = 3, 4, 5 (Vector control modes) SDS(4) Parameter Type=L2; PKW: 1HEX=0.1% PcD: 4000HEX=400%	-300.0 to 300.0 [%]	4 i001=-100.0 i002=-100.0 i003=-100.0 i004=-100.0	3 / BR 3 / BR
P499 * 1F3Hex	Src FixTorq 2 Source of the lower torque limit. Parameter values: 1001: upper limit for the torque setpoint (P498) 1002: not allowed other values: see process data wiring of the setpoint channel. Note: The lower torque limit can only be changed within the range specified by the limit for the regenerative operation torque setpoint (P498). Condition: P163 = 3, 4, 5 (Vector control modes) B/R Parameter Type=L2; PKW: PKW-Format(HEX)=Par Value PcD Gr.: 0	0 to 6045	2 i001=1001 i002=1001	3 / BR 3 / BR
P500 1F4Hex	FixTorq 2 Gain Proportional gain of the lower torque limit; not effective for fixed setpoint (P499 = 1001). B/R Parameter Type=L2; PKW: 1HEX=0.01% PcD Gr.: 0	-300.00 to 300.00 [%]	2 i001=100.00 i002=100.00	3 / BR 3 / BR
r502 1F6Hex	Fix Torque 2 Maximum value of the lower torque limit in % of rated motor torque. Display parameter of the output of the source of the lower torque limit (P499) Condition: P163 = 3, 4, 5 (Vector control modes) Analog Output: 100% @ Parameter Value=P485 Type=L2; PKW: 1HEX=0.1% PcD Gr.: 5	[%]	-	3 / BR

PNU	Parameter Name in OP1	Range [Unit]	# of. Indices	read: write:
*:conf-P	Description	Value texts	Factory Settings.	
r503 1F7Hex	Max Torque 2 Real lower torque limit in % of rated motor torque; this parameter is identical with r502 except for torque control. Note: The value of this parameter may be reduced by the power limit (P233) or the current limit (P173). P235 displays the effective torque limit. Condition: P163 = 3, 4, 5 (Vector control modes) Analog Output: 100% @ Parameter Value=P485 Type=L2; PKW: 1HEX=0.1% PcD Gr.: 5	[%]	-	3/ BR
P505 1F9Hex	Torq/I Fix Set Fixed setpoint for the additional torque / current setpoint in % of the rated motor torque / current (P102). Notes: • For speed or torque control (P163 = 4, 5): supplementary torque, for frequency control (P163 = 3) and P508 = 1: additional torque setpoint • For frequency control (P163 = 3): additional current setpoint (if the counter EMF model is not active (r286 = 0) and if P508 = 0). Condition: P163 = 3, 4, 5 (Vector control modes) SDS(4) Parameter Type=L2; PKW: 1HEX=0.1% PcD: 4000HEX=400%	-300.0 to 300.0 [%]	4 i001=5.0 i002=5.0 i003=5.0 i004=5.0	3/ BR 3/ BR
P506 * 1FAHex	Src T/I FixAddSP Source of the additional torque / current setpoint. Notes: • For speed / torque control (P163 = 4, 5): source of the additional torque setpoint • For frequency control (P163 = 3): source of the additional current setpoint or additional torque setpoint depending on P508. Parameter values: 1001: Fixed torque setpoint (P505) 1002: not allowed other values: see process data wiring of the setpoint channel. B/R Parameter Type=L2; PKW: PKW-Format(HEX)=Par Value PcD Gr.: 0	0 to 6045	2 i001=0 i002=0	3/ BR 3/ BR
P507 1FBHex	T/I FixAddSetGain Proportional gain of the additional torque / current setpoint Note: Not effective at internal setpoint (P506 = 1001). B/R Parameter Type=L2; PKW: 1HEX=0.01% PcD Gr.: 0	-300.00 to 300.00 [%]	2 i001=100.00 i002=100.00	3/ BR 3/ BR
P508 1FCHex	T add For frequency control (P163 = 3), it can be selected as to whether the torque/current supplementary setpoint source (P506) is to be used to impress current in the range of the current model (r286 = 0), for torque feed-forward control (r244) of the frequency controller or as supplementary torque for a slave drive (P587). Parameter values: 0: I supplementary 1: T supplementary B/R parameter Type=O2 PKW: 1HEX=1.0 PcD Gr.: -	0 to 1 no yes	2 i001=1.00 i002=1.00	3/ BR 3/ BR
r510 1FEHex	Torq/I FixAddSet Additional torque / current setpoint in % of rated motor torque / rated motor current; display parameter of the output of the source for the additional torque / current setpoint (P506) Analog Output: 100% @ Parameter Value=P485 Type=L2; PKW: 1HEX=0.1% PcD Gr.: 5	[%]	-	3/ BR

PNU	Parameter Name in OP1	Range [Unit]	# of. Indices	read: <input type="checkbox"/> write: <input type="checkbox"/>
*:conf-P	Description	Value texts	Factory Settings.	
P512 200Hex	Compare Freq Compare frequency for the message 'Compare frequency reached' (status word 1, bit 10 (r552)); see also P513 (Hysteresis) Type=I4; PKW: 1HEX=0.01Hz PcD Gr.: 1	0.00 to 600.00 [Hz]	- 50.00	3 / BR 3 / BR
P513 201Hex	Comp Freq. Hyst Hysteresis for the message 'Compare frequency reached' in % of the compare frequency (P512) Type=O2; PKW: 1HEX=0.1% PcD Gr.: 0	0.0 to 100.0 [%]	- 3.0	3 / BR 3 / BR
P514 202Hex	OFF Frequency Pulse block frequency at turn OFF If after an OFF command (OFF1, OFF3) the actual value of the frequency (r218) comes below this value, the pulses are blocked after the OFF wait time (P516). Type=I4; PKW: 1HEX=0.01Hz PcD Gr.: 1	0.00 to 600.00 [Hz]	- 0.10	3 / BR 3 / BR
P516 204Hex	OFF Wait Time Wait time between reaching of the pulse block frequency (P514) and pulse blocking; only for turn OFF via OFF1 or OFF3. SDS(4) Parameter Type=O2; PKW: 1HEX=0.1s PcD Gr.: 0	0.0 to 60.0 [s]	4 i001=0.0 i002=0.0 i003=0.0 i004=0.0	3 / BR 3 / BR
P517 205Hex	Deviation Freq Deviation frequency for the message 'Set/Actual deviation' (status word 1, bit 8 (r552)); the message is issued if the deviation is higher than the parameter value; see also P518 (deviation time) Depending items: P520 (pull out / blocking wait time) Type=I4; PKW: 1HEX=0.01Hz PcD Gr.: 1	0.00 to 600.00 [Hz]	- 3.00	3 / BR 3 / BR
P518 206Hex	Deviation Time Minimum time of the Set/Actual deviation; after this minimum time a Set/Actual deviation (P517) issues the message 'Set/Actual deviation' (status word 1, bit 8 (r552)) Depending items: P520 (pull out / blocking wait time) Type=O2; PKW: 1HEX=0.1s PcD Gr.: -	0.0 to 10.0 [s]	- 3.0	3 / BR 3 / BR
P519 207Hex	Overspeed Hyst Hysteresis of the message 'overspeed' (status word 2, bit 18 (r553)) Scaling quantity: reference values of P452 (Maximum forward frequency) and P453 (Maximum reverse frequency) Type=O2; PKW: 1HEX=0.1% PcD Gr.: -	0.0 to 20.0 [%]	- 10.0	3 / BR 3 / BR
P520 208Hex	PullOut/BlckTime Wait time between the message 'motor pulled out/blocked' and issuing a fault message Dependent parameters: P517 (speed of the set/actual deviation), P518 (set/actual deviation time) MDS(4) Parameter Type=O2; PKW: 1HEX=0.01s PcD Gr.: 0	0.00 to 100.00 [s]	4 i001=50.00 i002=50.00 i003=50.00 i004=50.00	3 / BR 3 / BR
P525 20DHex	Fix Setp ProcReg Fixed setpoints for the technology controller B/R parameter Type=I4; PKW: 1HEX=0.001 % PcD: 4000_0000HEX=100.00 %	-200.000 to 200.000 [%]	2 i001=0.000 i002=0.000	3 / BR 3 / BR

PNU	Parameter Name in OP1	Range [Unit]	# of. Indices	read: write:
*:conf-P	Description	Value texts	Factory Settings.	
P526 * 20EHex	Src ProcReg Setp Source for the technology controller setpoint. Parameter values: 1001: Technology setpoint (P525) 1002: Not permissible Additional value: According to PcD wiring of the setpoint channel B/R parameter Type=L2; PKW: PKW-Format(HEX)=Par Value PcD Gr.: 0	0 to 6045	2 i001=0 i002=0	3 / BR 3 / BR
P527 20FHex	SetpGain ProcReg Technology controller setpoint gain. Not effective for technology setpoint input via fixed setpoint (P526 = 1001). B/R parameter Type=O2; PKW:1HEX=0.01 % PcD Gr.: 0	-300.00 to 300.00 [%]	2 i001=100.00 i002=100.00	3 / BR 3 / BR
P528 * 210Hex	SmoothProcRegSet Technology controller setpoint smoothing time constant. The smoothing first becomes active when the technology controller is activated (control word 2 bit 24 = 1 and RUN status). Type=O2; PKW:1HEX=0.01 s PcD Gr.: 0	0.00 to 600.00 [s]	- 0.00	3 / BR 3 / BR
r529 211Hex	Setpoint ProcReg Actual technological setpoint Analog output: 100 % for PWE=100.000 % Type=l2; PKW: 1HEX=0.001 % PcD: 4000_0000HEX=100.00 %	[%]	-	3 / BR
P530 * 212Hex	ActVal's ProcReg Actual values for the technology controller actual value input. Defines which parameter are used as actual values for the technology controller. Indices: i001 = W01: Value1 for technology controller i002 = W02: Value2 for technology controller Type=O2; PKW: 1HEX=1.0 PcD Gr.: 0	0 to 999	2 i001=0.0 i002=0.0	3 / BR 3 / BR
P531 * 213Hex	SRC ProcReg ActV Source of the technology controller actual value. Parameter values: 1001: Illegal 1002: Illegal 1020: Illegal 1100: Internal technology controller actual value 1 (= contents of P530 index i001) 1200: Internal technology controller actual value 2 (= contents of P530 index i002) Additional values: According to the PcD wiring of the setpoint channel B/R parameter Type=L2; PKW: PKW format(HEX)=Par Value PcD Gr.: 0	0 to 6045	2 i001=0 i002=0	3 / BR 3 / BR
P532 * 214Hex	Gain ProcRegActV Technology controller actual value gain. B/R parameter Type=l2; PKW: 1HEX=0.01 % PcD Gr.: 0	-300.00 to 300.00 [%]	2 i001=100.00 i002=100.00	3 / BR 3 / BR
P533 * 215Hex	Smth ProcRegActV Smoothing time constant of the technology controller actual value. The smoothing is only active if the technology controller has been activated (control word2 bit 24 = 1 and status RUN). Type=O2; PKW:1HEX=0.01 s PcD Gr.: 0	0.00 to 600.00 [s]	- 0.00	3 / BR 3 / BR

PNU	Parameter Name in OP1	Range [Unit]	# of. Indices	read: <input type="checkbox"/> write: <input type="checkbox"/>
*:conf-P	Description	Value texts	Factory Settings.	
r534 216Hex	ActValue ProcReg Actual technological actual value Analog output: 100 % at PWE=100.000 % Type=I2; PKW: 1HEX=0.001 % PcD: 4000_0000HEX=100.000 %	[%]	–	3 / BR
P535 * 217Hex	R,g. T:Hyst. Hysteresis for the signal - technological setpoint reached. This signal is output, if the technological actual value (r534) is greater than the technological setpoint (r529). The hysteresis is only effective when this signal is withdrawn Type=O2; PKW:1HEX=0.1 % PcD: 4000HEX=100.0 %	0.0 to 100.0 [%]	– 3.0	3 / BR 3 / BR
r536 218Hex	DeviationProcReg Control deviation at the input of the technology controller. Analog output: 100 % at PWE=100.00 % Type=I4; PKW: 1HEX=0.001 % PcD: 4000_0000HEX=100.00 %	[%]		3 / BR
P537 219Hex	Gain ProcReg Technology controller gain. Type=O2; PKW:1HEX=0.01 PcD: 4000HEX=64.00	0.00 to 250.00	– 1.00	3 / BR 3 / BR
P538 21AHex	IntConstProcReg Technology controller integral action time (I component). Setting information: The technology controller I component is disabled with the value 0.00. Type=O2; PKW:1HEX=0.01 s PcD Gr.: 0	0.00 to 600.00 [s]	– 0.00	3 / BR 3 / BR
P539 21BHex	DifConstProcReg Technology controller derivative action time (D component). Setting information: The technology controller D component is disabled with the value 0.00. Type=O2; PKW:1HEX=0.01 s PcD Gr.: 0	0.00 to 300.00 [s]	– 0.00	3 / BR 3 / BR
r540 21CHex	ProcReg Output Technology controller output before the limit value stage (P541, P542). Analog output: 100 % at PWE=100.00 % Type=I4; PKW: 1HEX=0.001 % PcD: 4000_0000HEX=100.000 %	[%]	–	3 / BR
P541 21DHex	ProcReg Up1Limit Upper limit of the technology controller output. Type=I4; PKW:1HEX=0.001 % PcD: 4000_0000HEX=100.000 %	–200.000 to 200.000 [%]	– 200.000	3 / BR 3 / BR
P542 21EHex	ProcReg Up2Limit Lower limit of the technology controller output. Type=I4; PKW:1HEX=0.001 % PcD: 4000_0000HEX=100.000 %	–200.000 to 200.000 [%]	– 200.000	3 / BR 3 / BR
P543 * 21FHex	ProcReg AccTime1 Ramp-function generator for the upper limit value of the technology controller output. Type=O2; PKW:1HEX=0.01 s PcD Gr.: 0	0.00 to 100.00 [s]	– 0.00	3 / BR 3 / BR
P544 * 220Hex	ProcReg AccTime2 Ramp-function generator for the lower limit value of the technology controller output. Type=O2; PKW:1HEX=0.01 s PcD Gr.: 0	0.00 to 100.00 [s]	– 0.00	3 / BR 3 / BR
r545 221Hex	ProcReg Out(Lim) Limited technology controller output (after the limit value stage). Analog output: 100 % at PWE=100.00 % Type=I4; PKW: 1HEX=0.001 % PcD: 4000_0000HEX=100.000 %	[%]	–	3 / BR

11.9 Control and Status Word

PNU	Parameter Name in OP1	Range [Unit]	# of. Indices	read: write:
*:conf-P	Description	Value texts	Factory Settings.	
r550 226Hex	Control Word 1 Display of the control word 1 (bits 0 to 15); see section „Control word“ in the Operating Instructions, Part 2  Type=V2; PKW: 1HEX=1.0 PcD Gr.: 0		-	2 / BR
r551 227Hex	Control Word 2 Display of the control word 2 (bits 16 to 31); see section „Control word“ in the Operating Instructions, Part 2.  Type=V2; PKW: 1HEX=1.0 PcD Gr.: 0		-	2 / BR
r552 228Hex	Status Word 1 Display of the status word 1 (bits 0 to 15); see section „Control word“ in the Operating Instructions, Part 2.  Type=V2; PKW: 1HEX=1.0 PcD Gr.: 0		-	2 / BR
r553 229Hex	Status Word 2 Display of the status word 2 (bits 16 to 31); see section „Control word“ in the Operating Instructions, Part 2.  Type=V2; PKW: 1HEX=1.0 PcD Gr.: 0		-	2 / BR
P554 * 22AHex	Src ON/OFF1 Source of the 'ON/OFF1' command (Control word 1, bit 0) Details see section „Control word“ in the Operating Instructions, Part 2 Parameter values: 0: OFF1 1: not allowed 1001: CU binary input 1 1003: CU binary input 3 1010: PMU ON/OFF keys 2001: SST1, Word 1, Bit 0 other values: refer to permissible settings in Section „Control word“ in the Operating Instructions, Part 2 (PcD connection of the control word) Note: When using the inputs of the serial IO system, values 4101 or 4201 are recommended. B/R Parameter Type=L2; PKW: PKW-Format(HEX)=Par Value PcD Gr.: 0	0 to 6001	2 P077=0 i001=1010 i002=1001 P077=1,2 i001=2001 i002=1001 P077=3 i001=1003 i002=1001	2 / BR 2 / BR
P555 * 22BHex	Src1 OFF2(coast) Source 1 of the 'OFF2' command (Coasting; control word 1, bit 1) Details see section „Control word“ in the Operating Instructions, Part 2 Parameter values: 0: not allowed 1: condition for operation 1002: Binary input 1 of the CU board other values: refer to permissible settings in Section „Control word“ in the Operating Instructions, Part 2 (PcD connection of the control word) B/R Parameter Type=L2; PKW: PKW-Format(HEX)=Par Value PcD Gr.: 0	1 to 6001	2 i001=1 i002=1002	2 / BR 2 / BR

PNU	Parameter Name in OP1	Range [Unit]	# of Indices	read: <u>_</u>/<u>_</u> write: <u>_</u>/<u>_</u>
*:conf-P	Description	Value texts	Factory Settings.	
P556 * 22CHex	Src2 OFF2(coast) Source 2 of the 'OFF2' command (Coasting; control word 1, bit 1) Description see P555 B/R Parameter Type=L2; PKW: PKW-Format(HEX)=Par Value PcD Gr.: 0	1 to 6001	2 i001=1 i002=1	2 / BR 2 / BR
P557 * 22DHex	Src3 OFF2(coast) Source 3 of the 'OFF2' command (Coasting; control word 1, bit 1) Description see P555 B/R Parameter Type=L2; PKW: PKW-Format(HEX)=Par Value PcD Gr.: 0	1 to 6001	2 i001=1 i002=1	2 / BR 2 / BR
P558 * 22EHex	Src1 OFF3(QStop) Source 1 of the 'OFF3' command (quick stop; control word 1, bit 2) Details see section „Control word“ in the Operating Instructions, Part 2 Parameter values: 0: not allowed 1: condition for operation 1006 binary input 6 of CU board 1010: PMU OFF key other values: refer to permissible settings in Section „Control word“ in the Operating Instructions, Part 2 (PcD connection of the control word) B/R Parameter Type=L2; PKW: PKW-Format(HEX)=Par Value PcD Gr.: 0	1 to 6001	2 P077=0,1 i001=1 i002=1 P077=2,3 i001=1006 i002=1	2 / BR 2 / BR
P559 * 22FHex	Src2 OFF3(QStop) Source 2 of the 'OFF3' command (quick stop; control word 1, bit 2) Description see P558 B/R Parameter Type=L2; PKW: PKW-Format(HEX)=Par Value PcD Gr.: 0	1 to 6001	2 i001=1 i002=1	2 / BR 2 / BR
P560 * 230Hex	Src3 OFF3(QStop) Source 3 of the 'OFF3' command (quick stop; control word 1, bit 2) Description see P558 B/R Parameter Type=L2; PKW: PKW-Format(HEX)=Par Value PcD Gr.: 0	1 to 6001	2 i001=1 i002=1	2 / BR 2 / BR
P561 * 231Hex	Src InvRelease Source of the 'inverter release' command (control word 1, bit 3) Details see section „Control word“ in the Operating Instructions, Part 2 Parameter values: 0: Inverter blocked 1: automatic release after wait times other values: refer to permissible settings in Section „Control word“ in the Operating Instructions, Part 2 (PcD connection of the control word) B/R Parameter Type=L2; PKW: PKW-Format(HEX)=Par Value PcD Gr.: 0	0 to 6001	2 i001=1 i002=1	3 / BR 3 / BR
P562 * 232Hex	Src RampGen Rel Source of the 'ramp generator release' command (control word 1, bit 4) Details see section „Control word“ in the Operating Instructions, Part 2 Parameter values: 0: Ramp generator blocked 1: automatic release after wait times other values: refer to permissible settings in Section „Control word“ in the Operating Instructions, Part 2 (PcD connection of the control word) B/R Parameter Type=L2; PKW: PKW-Format(HEX)=Par Value PcD Gr.: 0	0 to 6001	2 i001=1 i002=1	3 / BR 3 / BR

PNU	Parameter Name in OP1	Range [Unit]	# of Indices	read: write:
*:conf-P	Description	Value texts	Factory Settings.	
P563 * 233Hex	Src RampGen Stop Source of the 'ramp generator stop' command (control word 1, bit 5) Details see section „Control word“ in the Operating Instructions, Part 2 Parameter values: 0: ramp generator stopped 1: ramp generator released other values: refer to permissible settings in Section „Control word“ in the Operating Instructions, Part 2 (PcD connection of the control word) B/R Parameter Type=L2; PKW: PKW-Format(HEX)=Par Value PcD Gr.: 0	0 to 6001	2 i001=1 i002=1	3 / BR 3 / BR
P564 * 234Hex	Src Setp Release Source of the 'setpoint release' command (control word 1, bit 6) Details see section „Control word“ in the Operating Instructions, Part 2 Parameter values: 0: Ramp generator input is set to '0' 1: Setpoint at ramp generator input other values: refer to permissible settings in Section „Control word“ in the Operating Instructions, Part 2 (PcD connection of the control word) B/R Parameter Type=L2; PKW: PKW-Format(HEX)=Par Value PcD Gr.: 0	0 to 6001	2 i001=1 i002=1	3 / BR 3 / BR
P565 * 235Hex	Src1 Fault Reset Source 1 of the 'reset' command (control word 1, bit 7) Details see section „Control word“ in the Operating Instructions, Part 2 Parameter values: 0: no source selected for reset 1: not allowed 1003: Binary input 3 of the CU board 1004: Binary input 4 of the CU board other values: refer to permissible settings in Section „Control word“ in the Operating Instructions, Part 2 (PcD connection of the control word) Note: The control command 'acknowledge' is edge triggered. B/R Parameter Type=L2; PKW: PKW-Format(HEX)=Par Value PcD Gr.: 0	0 to 6001	2 P077=0,1,2 i001=0 i002=1003 P077=3 i001=1004 i002=1003	2 / BR 2 / BR
P566 * 236Hex	Src2 Fault Reset Source 2 of the 'reset' command (control word 1, bit 7) Description see P565 B/R Parameter Type=L2; PKW: PKW-Format(HEX)=Par Value PcD Gr.: 0	0 to 6001	2 i001=0 i002=0	2 / BR 2 / BR
P567 * 237Hex	Src3 Fault Reset Source 3 of the 'reset' command (control word 1, bit 7) Description see P565 B/R Parameter Type=L2; PKW: PKW-Format(HEX)=Par Value PcD Gr.: 0	0 to 6001	2 i001=2001 i002=2001	2 / BR 2 / BR
P568 * 238Hex	Src Jog1 ON Source of the 'Jog 1' command (control word 1, bit 8) Details see section „Control word“ in the Operating Instructions, Part 2 Parameter values: 0: no Jog operation 1: not allowed 2001: SST1, Word 1, Bit 8 other values: refer to permissible settings in Section „Control word“ in the Operating Instructions, Part 2 (PcD connection of the control word) B/R Parameter Type=L2; PKW: PKW-Format(HEX)=Par Value PcD Gr.: 0	0 to 6001	2 P077=0,3 i001=0 i002=0 P077=1,2 i001=2001 i002=0	2 / BR 2 / BR

PNU *:conf-P	Parameter Name in OP1 Description	Range [Unit] Value texts	# of. Indices Factory Settings.	read: <u>/</u> write: <u>/</u>
P569 * 239Hex	Src Jog2 ON Source of the 'Jog 2' command (control word 1, bit 9) Description see P568 B/R Parameter Type=L2; PKW: PKW-Format(HEX)=Par Value PcD Gr.: 0	0 to 6001	2 i001=0 i002=0	2 / BR 2 / BR
P571 * 23BHex	Src FWD speed Source of the 'forward speed' command (control word 1, bit 11) Parameter values: 0: forward speed blocked 1: forward speed released 1010: PMU forward/reverse key 2001: SST1, Word 1, Bit 11 other values: refer to permissible settings in Section „Control word“ in the Operating Instructions, Part 2 (PcD connection of the control word) Note: Both parameters P571 and P572 or the sources defined by them define which of the directions are really released: <div style="text-align: center;">  </div> B/R Parameter Type=L2; PKW: PKW-Format(HEX)=Par Value PcD Gr.: 0	0 to 6001	2 P077=0,3 i001=1 i002=1 P077=1,2 i001=2001 i002=1	2 / BR 2 / BR
P572 * 23CHex	Src REV speed Source of the 'reverse speed' command (control word 1, bit 12) Parameter values: 0: reverse speed blocked 1: reverse speed released 1010: PMU forward/reverse key 2001: SST1, Word 1, Bit 12 other values: refer to permissible settings in Section „Control word“ in the Operating Instructions, Part 2 (PcD connection of the control word) Note: Welche Drehrichtungen wirklich freigegeben sind, wird über die beiden Parameter P571 und P572 bzw. über die Werte, die von den von diesen Parametern bestimmten Quellen geliefert werden, bestimmt: siehe P571. B/R Parameter Type=L2; PKW: PKW-Format(HEX)=Par Value PcD Gr.: 0	0 to 6001	2 P077=0,3 i001=1 i002=1 P077=1,2 i001=2001 i002=1	2 / BR 2 / BR
P573 * 23DHex	Src MOP UP Source of the command 'motor operated potentiometer (MOP) UP' (control word 1, bit 13) Parameter values: 0: not active 1: not allowed 1010: PMU UP key 2001: SST1, Word 1, Bit 13 other values: refer to permissible settings in Section „Control word“ in the Operating Instructions, Part 2 (PcD connection of the control word) B/R Parameter Type=L2; PKW: PKW-Format(HEX)=Par Value PcD Gr.: 0	0 to 6001	2 P077=0,3 i001=1010 i002=0 P077=1,2 i001=2001 i002=0	2 / BR 2 / BR

PNU	Parameter Name in OP1	Range [Unit]	# of. Indices	read: write:
*:conf-P	Description	Value texts	Factory Settings.	L /
P574 * 23EHex	Src MOP DOWN Source of the command 'motor operated potentiometer (MOP) DOWN' (control word 1, bit 14) Parameter values: 0: not active 1: not allowed 1010: PMU DOWN key 2001: SST1, Word 1, Bit 14 other values: refer to permissible settings in Section „Control word“ in the Operating Instructions, Part 2 (PcD connection of the control word) B/R Parameter Type=L2; PKW: PKW-Format(HEX)=Par Value PcD Gr.: 0	0 to 6001	2 P077=0,3 i001=1010 i002=0 P077=1,2 i001=2001 i002=0	2 / BR 2 / BR
P575 * 23FHex	Src No Ext Fault1 Source of the message 'external fault 1' (control word 2, bit 27); L-level causes fault trip of the drive Parameter values: 0: not allowed 1: no external fault 1 1001: Binary input 1 of CU board other values: refer to permissible settings in Section „Control word“ in the Operating Instructions, Part 2 (PcD connection of the control word) B/R Parameter Type=L2; PKW: PKW-Format(HEX)=Par Value PcD Gr.: 0	1 to 6001	2 P077=0,1 i001=1 i002=1 P077=2,3 i001=1001 i002=1	2 / BR 2 / BR
P576 * 240Hex	Src SetpDSetBit0 Source of bit 0 for the selection of the setpoint channel data set (SDS; control word 2, bit 16) Parameter values: 0: SDS bit 0 has value of 0 1: SDS bit 0 has value of 1 other values: refer to permissible settings in Section „Control word“ in the Operating Instructions, Part 2 (PcD connection of the control word) B/R Parameter Type=L2; PKW: PKW-Format(HEX)=Par Value PcD Gr.: 0	0 to 6004	2 i001=0 i002=0	3 / BR 3 / BR
P577 * 241Hex	Src SetpDSetBit1 Source of bit 1 for the selection of the setpoint channel data set (SDS; control word 2, bit 17) Parameter values: 0: SDS bit 1 has value of 0 1: SDS bit 1 has value of 1 other values: refer to permissible settings in Section „Control word“ in the Operating Instructions, Part 2 (PcD connection of the control word) B/R Parameter Type=L2; PKW: PKW-Format(HEX)=Par Value PcD Gr.: 0	0 to 6004	2 i001=0 i002=0	3 / BR 3 / BR
P578 * 242Hex	Src MotDSet Bit0 Source of bit 0 for the selection of motor data set (MDS; control word 2, bit 18) Parameter values: 0: MDS bit 0 has value of 0 1: MDS bit 0 has value of 1 other values: refer to permissible settings in Section „Control word“ in the Operating Instructions, Part 2 (PcD connection of the control word) Note: The motor data set can not be changed during operation; a change of this bit will only become effective in the ready state. B/R Parameter Type=L2; PKW: PKW-Format(HEX)=Par Value PcD Gr.: 0	0 to 6004	2 i001=0 i002=0	3 / BR 3 / BR

PNU	Parameter Name in OP1	Range [Unit]	# of Indices	read: <input type="checkbox"/> write: <input type="checkbox"/>
*:conf-P	Description	Value texts	Factory Settings.	
P579 * 243Hex	Src MotDSet Bit1 Source of bit 1 for the selection of motor data set(MDS; control word 2, bit 19) Parameter values: 0: MDS bit 1 has value of 0 1: MDS bit 1 has value of 1 other values: refer to permissible settings in Section „Control word“ in the Operating Instructions, Part 2 (PcD connection of the control word) Note: The motor data set can not be changed during operation; a change of this bit will only become effective in the ready state. B/R Parameter Type=L2; PKW: PKW-Format(HEX)=Par Value PcD Gr.: 0	0 to 6004	2 i001=0 i002=0	3 / BR 3 / BR
P580 * 244Hex	Src FixSetp Bit0 Source of bit 0 to select a fixed setpoint FS (control word 2, bit 20) Parameter values: 0: FS bit 0 has value of 0 1: FS bit 0 has value of 1 other values: refer to permissible settings in Section „Control word“ in the Operating Instructions, Part 2 (PcD connection of the control word) B/R Parameter Type=L2; PKW: PKW-Format(HEX)=Par Value PcD Gr.: 0	0 to 6004	2 i001=0 i002=1004	2 / BR 2 / BR
P581 * 245Hex	Src FixSetp Bit1 Source of bit 1 to select a fixed setpoint FS (control word 2, bit 21) Parameter values: 0: FS bit 1 has value of 0 1: FS bit 1 has value of 1 other values: refer to permissible settings in Section „Control word“ in the Operating Instructions, Part 2 (PcD connection of the control word) B/R Parameter Type=L2; PKW: PKW-Format(HEX)=Par Value PcD Gr.: 0	0 to 6004	2 i001=0 i002=0	2 / BR 2 / BR
P582 * 246Hex	Src Sync Release Source of the command 'release of synchronization' (control word 2, bit 22) Parameter values: 0: Synchronization not released 1: Synchronization released other values: refer to permissible settings in Section „Control word“ in the Operating Instructions, Part 2 (PcD connection of the control word) Condition: P163 = 2; TSY board B/R Parameter Type=L2; PKW: PKW-Format(HEX)=Par Value PcD Gr.: 0	0 to 6004	2 i001=0 i002=0	3 / BR 3 / BR
P583 * 247Hex	Src Fly Release Source of the command 'release of flying restart' (control word 2, bit 23) Parameter values: 0: Flying restart not released 1: Flying restart released with every ON command other values: refer to permissible settings in Section „Control word“ in the Operating Instructions, Part 2 (PcD connection of the control word) Dependent parameter: Special behavior in combination with the auto restart function see P366 (auto restart). Condition: P163 = 0.1 (motor type = IEC, NEMA) B/R Parameter Type=L2; PKW: PKW-Format(HEX)=Par Value PcD Gr.: 0	0 to 6004	2 i001=0 i002=0	2 / BR 2 / BR

PNU	Parameter Name in OP1	Range [Unit]	# of Indices	read: <input type="checkbox"/> write: <input type="checkbox"/>
*:conf-P	Description	Value texts	Factory Settings.	
P588 * 24CHex	Src No Ext Warn1 Source of the message 'external warning 1' (control word 2, bit 28) Parameter values: 0: not allowed 1: no external warning 1 1002: CU binary input 2 other values: refer to permissible settings in Section „Control word“ in the Operating Instructions, Part 2 (PcD connection of the control word) B/R Parameter Type=L2; PKW: PKW-Format(HEX)=Par Value PcD Gr.: 0	1 to 6004	2 P077=0,1 i001=1 i002=1 P077=2,3 i001=1002 i002=1	3 / BR 3 / BR
P589 * 24DHex	Src No Ext Warn2 Source of the message 'external warning 2' (control word 2, bit 29) Parameter values: 0: not allowed 1: no external warning 1 other values: refer to permissible settings in Section „Control word“ in the Operating Instructions, Part 2 (PcD connection of the control word) B/R Parameter Type=L2; PKW: PKW-Format(HEX)=Par Value PcD Gr.: 0	1 to 6004	2 i001=1 i002=1	3 / BR 3 / BR
P590 * 24EHex	Src Base/Reserve Source of the switching command 'base / reserve settings' (control word 2, bit 30) Parameter values: 0: base setting 1: reserve setting 1005: Binary input 5 of the CU board other values: refer to permissible settings in Section „Control word“ in the Operating Instructions, Part 2 (PcD connection of the control word) Type=L2; PKW: PKW-Format(HEX)=Par Value PcD Gr.: 0	0 to 6004	- 1005	3 / BR 3 / BR
P591 * 24FHex	Src ContactorMsg Source of the message 'main contactor energized' (control word 2, bit 31) Parameter values: 0: not allowed 1: no message, main contactor must be energized within 120 msec after the related command 1001 to 1005: CU terminals 4101 to 4116: SCB-SCI1 terminals (serial I/O) 4201 to 4216: SCB-SCI2 terminals (serial I/O) 5001: TSY terminal 1 Notes: If the function is active, pulses are released as soon as the message is available. No base / reserve settings possible Type=L2; PKW: PKW-Format(HEX)=Par Value PcD Gr.: 0	1 to 5001	- 1	3 / BR 3 / BR
P600 * 258Hex	Dst Ready for ON Destination of the status bit 'ready for turn ON' (status word 1, bit 0) Power is ON, the drive may be turned on. Parameter values: Depending on the selected index all settings according to section „Status word“ in the Operating Instructions, Part 2 (PcD connection of the status word) may be selected. Indices: i001: BD: selection of a base drive terminal i002: SCI: selection of a SCI1/2 terminal i003: TSY: selection of a TSY terminal Type=L2; PKW: PKW-Format(HEX)=Par Value PcD Gr.: 0	0 to 5002	3 i001=0 i002=0 i003=0	3 / BR 3 / BR

PNU	Parameter Name in OP1	Range [Unit]	# of. Indices	read: write:
*:conf-P	Description	Value texts	Factory Settings.	/ /
P601 * 259Hex	Dst Rdy for Oper Destination of the status bit 'ready for operation' (status word 1, bit 1) The DC bus is charged, pulses may be released and the drive may be turned ON, respectively. Parameter values, indices: as P600. Type=L2; PKW: PKW-Format(HEX)=Par Value PcD Gr.: 0	0 to 5002	3 i001=0 i002=0 i003=0	3 / BR 3 / BR
P602 * 25AHex	Dst Operation Destination of the status bit 'operation' (status word 1, bit 2) The drive is in operation. Parameter values, Indices: as P600 Type=L2; PKW: PKW-Format(HEX)=Par Value PcD Gr.: 0	0 to 5002	3 P077=0,1 i001=1003 i002=0 i003=0 P077=2,3 i001=0 i002=0 i003=0	2 / BR 2 / BR
P603 * 25BHex	Dst Fault Destination of the status bit 'fault' (status word 1, Bit 3) Note: for issuing the fault message via a terminal the active status (bit has H-level) is inverted (broken wire proof). Parameter values, Indices: as P600 Type=L2; PKW: PKW-Format(HEX)=Par Value PcD Gr.: 0	0 to 5002	3 i001=1002 i002=0 i003=0	2 / BR 2 / BR
P604 * 25CHex	Dst NO OFF2 Destination of the status bit 'no OFF2 command' (status word 1, bit 4) Parameter values, Indices: as P600 Type=L2; PKW: PKW-Format(HEX)=Par Value PcD Gr.: 0	0 to 5002	3 i001=0 i002=0 i003=0	3 / BR 3 / BR
P605 * 25DHex	Dst NO OFF3 Destination of the status bit 'no OFF3 command' (status word 1, bit 5) Parameter values, Indices: as P600 Type=L2; PKW: PKW-Format(HEX)=Par Value PcD Gr.: 0	0 to 5002	3 i001=0 i002=0 i003=0	3 / BR 3 / BR
P606 * 25EHex	Dst ON blocked Destination of the status bit 'turn-ON locked' (status word 1, bit 6) Note: for issuing the message via a terminal the active status (bit has H-level) is inverted (broken wire proof). Parameter values, Indices: as P600 Type=L2; PKW: PKW-Format(HEX)=Par Value PcD Gr.: 0	0 to 5002	3 i001=0 i002=0 i003=0	3 / BR 3 / BR
P607 * 25FHex	Dst Warning Destination of the status bit 'warning' (status word 1, bit 7) Note: for issuing the message via a terminal the active status (bit has H-level) is inverted (broken wire proof). Parameter values, Indices: as P600 Type=L2; PKW: PKW-Format(HEX)=Par Value PcD Gr.: 0	0 to 5002	3 P077=0,1 i001=0 i002=0 i003=0 P077=2,3 i001=1003 i002=0 i003=0	2 / BR 2 / BR
P608 * 260Hex	Dst Deviation Destination of the status bit 'set frequency = act. frequency' (status word 1, bit 8) - see P517; for details see section „Status word“ in Operating Instructions, Part 2 Parameter values, Indices: as P600 Type=L2; PKW: PKW-Format(HEX)=Par Value PcD Gr.: 0	0 to 5002	3 i001=0 i002=0 i003=0	3 / BR 3 / BR

PNU	Parameter Name in OP1	Range [Unit]	# of Indices	read: <input type="checkbox"/> write: <input type="checkbox"/>
*:conf-P	Description	Value texts	Factory Settings.	
P610 * 262Hex	Dst CompareFreq Destination of the status bit 'compare frequency reached' (status word 1, bit 10 - see P512; for details see section „Status word“ in Operating Instructions, Part 2 Parameter values, Indices: as P600 Type=L2; PKW: PKW-Format(HEX)=Par Value PcD Gr.: 0	0 to 5002	3 i001=0 i002=0 i003=0	3 / BR 3 / BR
P611 * 263Hex	Dst Low Voltage Destination of the status bit 'undervoltage' (status word 1, bit 11) Note: for issuing the message via a terminal the active status (bit has H-level) is inverted (broken wire proof). Parameter values, Indices: as P600 Type=L2; PKW: PKW-Format(HEX)=Par Value PcD Gr.: 0	0 to 5002	3 i001=0 i002=0 i003=0	3 / BR 3 / BR
P612 * 264Hex	Dst Contactor Destination of the bit 'energize main contactor' (status word 1, bit 12) H-level: energize contactor! Note: If the message 'main contactor energized' is not selected (P591 = 1), the main contactor must be energized within 120 ms after the bit 'energize main contactor' is set. ATTENTION: For switching voltages between 50 and 230 V AC only the following relays may be used: - relay on the PEU or the PSU board (driven via binary output 1) or - the relays of the optional SCI boards, which are specified for 230 V AC (see section „Bypass- and output contactor“ in the Operating Instructions, Part 1) Parameter values, Indices: as P600 Type=L2; PKW: PKW-Format(HEX)=Par Value PcD Gr.: 0	0 to 5002	3 i001=1001 i002=0 i003=0	3 / BR 3 / BR
P613 * 265Hex	Dst RampGen act Destination of the status bit 'ramp generator active' (status word 1, bit 13) Parameter values, Indices: as P600 Type=L2; PKW: PKW-Format(HEX)=Par Value PcD Gr.: 0	0 to 5002	3 i001=0 i002=0 i003=0	3 / BR 3 / BR
P614 * 266Hex	Dst FWD speed Destination of the status bit 'speed direction' (status word 1, bit 14) Meanings: H-level: forward L-level: reverse Parameter values, Indices: as P600 Type=L2; PKW: PKW-Format(HEX)=Par Value PcD Gr.: 0	0 to 5002	3 i001=0 i002=0 i003=0	2 / BR 2 / BR
P615 * 267Hex	PRT/FLR active Destination of the status bit 'power ride thru (PRT) / flexible response (FLR) active' (status word 1, bit 15) Parameter values, Indices: as P600 Type=L2; PKW: PKW-Format(HEX)=Par Value PcD Gr.: 0	0 to 5002	3 i001=0 i002=0 i003=0	3 / BR 3 / BR
P616 * 268Hex	Dst Fly Restart Destination of the status bit 'flying restart active' and 'energization time running' (status word 2, bit 16) (refer to P189) Parameter values, Indices: as P600 Type=L2; PKW: PKW-Format(HEX)=Par Value PcD Gr.: 0	0 to 5002	3 i001=0 i002=0 i003=0	3 / BR 3 / BR
P617 * 269Hex	Dst Sync OK Destination of the status bit 'synchronized' (status word 2, bit 17) Parameter values, Indices: as P600 Type=L2; PKW: PKW-Format(HEX)=Par Value PcD Gr.: 0	0 to 5002	3 i001=0 i002=0 i003=5001	3 / BR 3 / BR

PNU	Parameter Name in OP1 Description	Range [Unit] Value texts	# of. Indices Factory Settings.	read: write: / /
*:conf-P 26AHex	P618 Dst No Overspeed Destination of the status bit 'no overspeed' (status word 2, bit 18) Parameter values, Indices: as P600 Type=L2; PKW: PKW-Format(HEX)=Par Value PcD Gr.: 0	0 to 5002	3 i001=0 i002=0 i003=0	3 / BR 3 / BR
* 26BHex	P619 Dst Ext Fault 1 Destination of the status bit 'external fault 1' (status word 2, bit 19) Note: for issuing the message via a terminal the active status (bit has H-level) is inverted (broken wire proof). Parameter values, Indices: as P600 Type=L2; PKW: PKW-Format(HEX)=Par Value PcD Gr.: 0	0 to 5002	3 i001=0 i002=0 i003=0	3 / BR 3 / BR
* 26CHex	P620 Dst Ext Fault 2 Destination of the status bit 'external fault 2' (status word 2, bit 20) Note: <ul style="list-style-type: none"> for issuing the message via a terminal the active status (bit has H-level) is inverted (broken wire proof). If an ON command is active, L-level causes fault trip after 200 msec. Parameter values, Indices: as P600 Type=L2; PKW: PKW-Format(HEX)=Par Value PcD Gr.: 0	0 to 5002	3 i001=0 i002=0 i003=0	3 / BR 3 / BR
* 26DHex	P621 Dst Ext Warning Destination of the status bit 'external warning' (status word 2, bit 21) Note: for issuing the message via a terminal the active status (bit has H-level) is inverted (broken wire proof). Parameter values, Indices: as P600 Type=L2; PKW: PKW-Format(HEX)=Par Value PcD Gr.: 0	0 to 5002	3 i001=0 i002=0 i003=0	3 / BR 3 / BR
* 26EHex	P622 Dst i2t Drive Destination of the status bit 'warning drive overload' (status word 2, bit 22); see r010 (drive utilization) Note: for issuing the message via a terminal the active status (bit has H-level) is inverted (broken wire proof). Parameter values, Indices: as P600 Type=L2; PKW: PKW-Format(HEX)=Par Value PcD Gr.: 0	0 to 5002	3 i001=0 i002=0 i003=0	3 / BR 3 / BR
* 26FHex	P623 Dst TmpFlt Drive Destination of the status bit 'fault drive overtemperature' (status word 2, bit 23) Note: for issuing the message via a terminal the active status (bit has H-level) is inverted (broken wire proof). Parameter values, Indices: as P600 Type=L2; PKW: PKW-Format(HEX)=Par Value PcD Gr.: 0	0 to 5002	3 i001=0 i002=0 i003=0	3 / BR 3 / BR
* 270Hex	P624 Dst TmpWarnDrive Destination of the status bit 'warning drive overtemperature' (status word 2, bit 24) Note: for issuing the message via a terminal the active status (bit has H-level) is inverted (broken wire proof). Parameter values, Indices: as P600 Type=L2; PKW: PKW-Format(HEX)=Par Value PcD Gr.: 0	0 to 5002	3 i001=0 i002=0 i003=0	3 / BR 3 / BR

PNU	Parameter Name in OP1	Range [Unit]	# of Indices	read: / write: /
*:conf-P	Description	Value texts	Factory Settings.	
P625 * 271Hex	Dst TmpWarnMotor Destination of the status bit 'warning motor overtemperature' (status word 2, bit 25) Reason: The condition for the warning is met via the motor utilization calculation or via KTY84 sensor monitoring (see r008 (motor utilization), r009 (motor temperature), P360 (motor temperature warning), P362 (motor cooling), P363 (thermal time constant of the motor), P364 (duty cycle monitoring)). Note: for issuing the message via a terminal the active status (bit has H-level) is inverted (broken wire proof). Parameter values, Indices: as P600 Type=L2; PKW: PKW-Format(HEX)=Par Value PcD Gr.: 0	0 to 5002	3 i001=0 i002=0 i003=0	2 / BR 2 / BR
P626 * 272Hex	Dst TmpFit Motor Destination of the status bit 'fault motor overtemperature' (status word 2, bit 26) Reason: The condition for the fault is met via the motor utilization calculation or via KTY84 sensor monitoring (see r008 (motor utilization), r009 (motor temperature), P360 (motor temperature warning), P362 (motor cooling), P363 (thermal time constant of the motor), P364 (duty cycle monitoring)). Note: for issuing the message via a terminal the active status (bit has H-level) is inverted (broken wire proof). Parameter values, Indices: as P600 Type=L2; PKW: PKW-Format(HEX)=Par Value PcD Gr.: 0	0 to 5002	3 i001=0 i002=0 i003=0	2 / BR 2 / BR
P627 * 273Hex	Dst ProcReg A=S Destination connection of the status bit „technological setpoint reached“ (status word 2, bit27) Parameter values, indices: As for P600 Type=L2; PKW: PKW format(HEX)=Par Value PcD Gr.: 0	0 to 5002	3 i001=0 i002=0 i003=0	3 / BR 3 / BR
P628 * 274Hex	Dst PullOut/Blck Destination of the status bit 'fault motor pulled out / blocked' (status word 2, bit 28) Note: for issuing the message via a terminal the active status (bit has H-level) is inverted (broken wire proof). Parameter values, Indices: as P600 Type=L2; PKW: PKW-Format(HEX)=Par Value PcD Gr.: 0	0 to 5002	3 i001=0 i002=0 i003=0	3 / BR 3 / BR
P629 * 275Hex	Dst ChrgRelay ON Destination of the status bit 'charging relay energized' (status word 2, bit 29) Note: for issuing the message via a terminal the active status (bit has H-level) is inverted (broken wire proof). Parameter values, Indices: as P600 Type=L2; PKW: PKW-Format(HEX)=Par Value PcD Gr.: 0	0 to 5002	3 i001=0 i002=0 i003=0	3 / BR 3 / BR
P630 * 276Hex	Dst Sync Fault Destination of the status bit 'synchronization fault' (status word 2, bit 30) Note: for issuing the message via a terminal the active status (bit has H-level) is inverted (broken wire proof). Parameter values, Indices: as P600 Type=L2; PKW: PKW-Format(HEX)=Par Value PcD Gr.: 0	0 to 5002	3 i001=0 i002=0 i003=5002	3 / BR 3 / BR
P631 * 277Hex	Dst Pre-Charging Destination of the status bit 'charging active' (status word 2, bit 31) Parameter values, Indices: as P600 Type=L2; PKW: PKW-Format(HEX)=Par Value PcD Gr.: 0	0 to 5002	3 i001=0 i002=0 i003=0	3 / BR 3 / BR

11.10 Analog Input/Output

PNU	Parameter Name in OP1	Range [Unit]	# of. Indices	read: write:																
*:conf-P	Description	Value texts	Factory Settings.																	
P650 * 28AHex	CU AnalogInConf Configuration of the CU analog inputs; defines the kind of the analog input signals Parameter values <table style="margin-left: 20px; border: none;"> <tr> <td></td> <td style="text-align: center;">Terminals 27 and 30</td> <td style="text-align: center;">Terminals 29 and 32</td> <td></td> </tr> <tr> <td>0:</td> <td style="text-align: center;">-10 V ... + 10 V</td> <td style="text-align: center;">- 20 mA ... +</td> <td style="text-align: center;">-10V...+10V</td> </tr> <tr> <td>1:</td> <td style="text-align: center;">0 V ... + 10 V</td> <td style="text-align: center;">0 mA ... +</td> <td style="text-align: center;">0V...+10V</td> </tr> <tr> <td>2:</td> <td></td> <td style="text-align: center;">+ 4 mA ... + 20 mA</td> <td style="text-align: center;">4mA...20mA</td> </tr> </table> Notes: <ul style="list-style-type: none"> • Only one signal can be wired per input; alternatively voltage or current signals can be evaluated. • Voltage and current signals must be connected to different terminals. • Settings 1 and 2 only allow unipolar signals, i. e. the internal process data are also unipolar. • At setting 2 an input current < 2 mA causes a fault trip (broken wire proof) • The offset scaling of the analog inputs is done via P652. Indices: i001: CU-1: configuration of analog terminal 1 i002: CU-2: configuration of analog terminal 2 Type=O2; PKW: 1HEX=1.0 PcD Gr.: -		Terminals 27 and 30	Terminals 29 and 32		0:	-10 V ... + 10 V	- 20 mA ... +	-10V...+10V	1:	0 V ... + 10 V	0 mA ... +	0V...+10V	2:		+ 4 mA ... + 20 mA	4mA...20mA	0 to 2	2 i001=0 i002=0	2/ BR 2/ BR
	Terminals 27 and 30	Terminals 29 and 32																		
0:	-10 V ... + 10 V	- 20 mA ... +	-10V...+10V																	
1:	0 V ... + 10 V	0 mA ... +	0V...+10V																	
2:		+ 4 mA ... + 20 mA	4mA...20mA																	
P651 * 28BHex	CU AnalnSmooth Filter time constant of the CU analog inputs. Indices: i001: CU-1: filter time constant of analog input 1 i002: CU-2: filter time constant of analog input 2 Type=O2; PKW: 1HEX=1.0ms PcD Gr.: 0	4 to 1000 [ms]	2 i001=4 i002=4	2/ BR 2/ BR																
P652 28CHex	CU AnalogIn Offs Offset scaling of the CU analog inputs Description for setting see section „Analog inputs“ in the Operating Instructions, Part 2 Indices: i001: CU-1: offset of analog input 1 i002: CU-2: offset of analog input 2 Type=l2; PKW: 1HEX=0.001V PcD Gr.: 0	-20.000 to 20.000 [V]	2 i001=0.000 i002=0.000	2/ BR 2/ BR																
P655 * 28FHex	CU AnaOut ActVal Actual value output via the CU analog outputs Description for setting: enter the parameter number of the quantities, which are to be issued. Indices: i001: CU-1: analog output 1 i002: CU-2: analog output 2 Type=O2; PKW: 1HEX=1.0 PcD Gr.: 0	0 to 999	2 i001=218 i002=4	2/ BR 2/ BR																
P656 290Hex	CU AnalogOutGain Proportional gain of the CU analog output, see section „Analog inputs“ in the Operating Instructions, Part 2 Parameter values: P656= calculated output voltage at when the displayed parameter has a value of 100% The output voltage V(out) is calculated according to: $V(\text{out}) = \frac{\text{value of displayed parameter}}{100 \%} * P656 + P657$ Indices: i001: CU-1: calculated output voltage of analog output 1 i002: CU-2: calculated output voltage of analog output 2 Note: Maximum value of the output voltage: +/- 10 V Type=l2; PKW: 1HEX=0.01V PcD Gr.: 0	-320.00 to 320.00 [V]	2 i001=10.00 i002=10.00	2/ BR 2/ BR																

PNU	Parameter Name in OP1	Range [Unit]	# of. Indices	read: write:
*:conf-P	Description	Value texts	Factory Settings.	/ /
P665 299Hex	SCI AnaOut Gain Proportional gain of the SCI analog outputs Description for setting: see SCI manual Indices: see P664 Type=I2; PKW: 1HEX=0.01 PcD: 4000HEX=160V	-320.00 to 320.00	6 i001=10.00 i002=10.00 i003=10.00 i004=10.00 i005=10.00 i006=10.00	3 / BR 3 / BR
P666 29AHex	SCI AnaOut Offs Offset of the SCI analog outputs Indices: see P664 Type=I2; PKW: 1HEX=0.01V PcD: 4000HEX=160V	-100.00 to 100.00 [V]	6 i001=0.00 i002=0.00 i003=0.00 i004=0.00 i005=0.00 i006=0.00	3 / BR 3 / BR

11.11 Communications

PNU	Parameter Name in OP1	Range [Unit]	# of. Indices	read: / write: /
*:conf-P	Description	Value texts	Factory Settings.	
P680 * 2A8Hex	<p>SCom1 Act Value</p> <p>Actual value output via serial communication SST1</p> <p>Defines, which parameter is to be transferred at which telegram address.</p> <p>Notes:</p> <ul style="list-style-type: none"> Word 1 should be set for status word 1 (r968) For double word parameters (type I4) the related parameter number must be entered at two subsequent words; otherwise only the most significant word will be transferred The length (number of words) of the process data part of the telegram is set by P685, i001 <p>Indices: i001 = W01: Word 01 of the (process data part of the) telegram i002 = W02: Word 02 of the (process data part of the) telegram ... i016 = W16: Word 16 of the (process data part of the) telegram</p> <p>Type=O2; PKW: 1HEX=1.0 PcD Gr.: 0</p>	0 to 999	16 i001=968 i002=0 i003=0 i004=0 i005=0 i006=0 i007=0 i008=0 i009=0 i010=0 i011=0 i012=0 i013=0 i014=0 i015=0 i016=0	3 / BR 3 / BR
P681 * 2A9Hex	<p>SCom2 Act Value</p> <p>Actual value output via serial communication SST1</p> <p>Defines, which parameter is to be transferred at which telegram address.</p> <p>Notes:</p> <ul style="list-style-type: none"> Word 1 should be set for status word 1 (r968) For double word parameters (type I4) the related parameter number must be entered at two subsequent words; otherwise only the most significant word will be transferred The length (number of words) of the process data part of the telegram is set by P685, i001 <p>Indices: i001 = W01: Word 01 of the (process data part of the) telegram i002 = W02: Word 02 of the (process data part of the) telegram ... i016 = W16: Word 16 of the (process data part of the) telegram</p> <p>Type=O2; PKW: 1HEX=1.0 PcD Gr.: 0</p>	0 to 999	16 i001=968 i002=0 i003=0 i004=0 i005=0 i006=0 i007=0 i008=0 i009=0 i010=0 i011=0 i012=0 i013=0 i014=0 i015=0 i016=0	3 / BR 3 / BR
P682 2AAHex	<p>SCB Protocol</p> <p>SCB can be operated as</p> <ul style="list-style-type: none"> master for the SCI boards or as serial communications board <p>(see SCB manual).</p> <p>Parameter values: 0 = Master for SCI boards 1 = 4 wire USS 2 = 2 wire USS 3 = Peer to Peer 4 = not used 5 = not used</p> <p>Condition: SCB board must be reported via P090 and 0P91, respectively</p> <p>Type=O2; PKW: 1HEX=1.0 PcD Gr.: -</p>	0 to 5	- 0	3 / H BR 3 / H
P683 * 2ABHex	<p>SCom/SCB BusAddr</p> <p>Bus address of the serial communication interfaces (see section „Serial interfaces“ in the Operating Instructions, Part 2)</p> <p>Indices: i001 = SC01: bus address of serial comm. interface 1 (CU) i002 = SCB: SCB bus address, if P682 = 1, 2 i003 = SC02: bus address of serial comm. interface 2 (CU)</p> <p>Type=O2; PKW: 1HEX=1.0 PcD Gr.: -</p>	0 to 31	3 i001=0 i002=0 i003=0	3 / BR 3 / BR

PNU	Parameter Name in OP1	Range [Unit]	# of. Indices	read: write:
*:conf-P	Description	Value texts	Factory Settings.	/ /
P684 * 2ACHex	SCom/SCB Baud Serial interfaces baud rate Parameter values: 1: 300 Baud 8: 38400 Baud 2: 600 Baud 9: 57600 Baud 3: 1200 Baud 10: 76800 Baud 4: 2400 Baud 11: 93750 Baud 5: 4800 Baud 12: 115200 Baud 6: 9600 Baud 13: 187500 Baud 7: 19200 Baud Notes: Maximum baud rate for SST1 (i001) 38400 for SST2 (i003) 38400 for SCB dependent on the version and selected protocol, refer to the SCB operating instructions) Indices: i001 = SCo1: baud rate of serial comm. interface 1 (CU) i002 = SCB: SCB baud rate, if P682 = 1, 2, 3 i003=SCo2: baud rate of serial comm. interface 2 (CU) Type=O2; PKW: 1HEX=1.0 PcD Gr.: -	1 to 13	3 i001=6 i002=6 i003=6	3 / BR 3 / BR
P685 * 2ADHex	SCom/SCB PCV Number of words (16 bit) of the parameter data part in the net data block of the telegram. (see section „Serial interfaces“ in the Operating Instructions, Part 2) Parameter values: 0: no parameter data part in the telegram 3, 4 parameter data part is 3 (parameter identifier, Ind, parameter value), 4 words long 127 variable parameter data length for the transfer of parameter description and texts. Indices: i001 = SCo1: serial comm. interface 1 (CU) i002 = SCB: SCB, if P682 = 1, 2, 3 i003 = SCo2: serial comm. interface 2 (CU) Type=O2; PKW: 1HEX=1.0 PcD Gr.: -	0 to 127	3 i001=127 i002=3 i003=3	3 / BR 3 / BR
P686 * 2AEHex	SCom/SCB # PrDat Number of words (16 bit) of the process data part in the net data block of the telegram. (see section „Serial interfaces“ in the Operating Instructions, Part 2) Indices: i001 = SCo1: serial comm. interface 1 (CU) i002 = SCB: SCB, if P682 = 1, 2, 3 i003 = SCo2: serial comm. interface 2 (CU) Type=O2; PKW: 1HEX=1.0 PcD Gr.: -	0 to 16	3 i001=2 i002=2 i003=2	3 / BR 3 / BR
P687 * 2AFHex	SCom/SCB TigOFF Telegram OFF time of CU and SCB If no correct telegram is received within the parameterized time a fault trip is set. Description for setting: • Value 0: no monitoring, no fault trip; must be parameterized for sporadic (a-cyclic) telegrams, e. g. operator panel OP at serial comm. interface 1. • If a TB is inserted in slot 2 and an SCB in slot 3, then the value in i002 is ineffective. Indices: i001 = SCo1: serial comm. interface 1 (CU) i002 = SCB: SCB, if P682 = 1, 2, 3 i003 = SCo2: serial comm. interface 2 (CU) Type=O2; PKW: 1HEX=1.0ms PcD: 4000HEX=1638.4ms	0 to 6500 [ms]	3 i001=0 i002=0 i003=0	3 / BR 3 / BR

PNU	Parameter Name in OP1	Range [Unit]	# of. Indices	read: <input type="checkbox"/> write: <input type="checkbox"/>
*:conf-P	Description	Value texts	Factory Settings.	
P689 2B1Hex	<p>SCB Peer2PeerExt</p> <p>Immediate transfer on of data received via the peer to peer protocol of SCB.</p> <p>Mark of these words of the received peer to peer telegram which are to be transferred on immediately.</p> <p>Parameter values: 0: no immediate transfer (only to CU) 1: immediate transfer (and passing to CU)</p> <p>Indices: i001 = W01: Word 01 of the (process data part of the) telegram i002 = W02: Word 02 of the (process data part of the) telegram ... i016 = W16: Word 16 of the (process data part of the) telegram</p> <p>Condition: P688 = 3 (peer to peer protocol) Type=O2; PKW: 1HEX=1.0 PcD Gr.: -</p>	0 to 1 CU only Transfer	5 i001=0 i002=0 i003=0 i004=0 i005=0	3 / BR 3 / BR
P690 * 2B2Hex	<p>SCB Act Values</p> <p>Actual value output via the serial communications interface of the SCB board;</p> <p>defines, which parameter is to be transferred at which telegram address.</p> <p>Notes: • Word 1 should be set for status word 1 (r968) • For double word parameters (type I4) the related parameter number must be entered at two subsequent words; otherwise only the most significant word will be transferred • The length (number of words) of the process data part of the telegram is set by P685, index i002</p> <p>Indices: i001 = W01: Word 01 of the (process data part of the) telegram i002 = W02: Word 02 of the (process data part of the) telegram ... i016 = W16: Word 16 of the (process data part of the) telegram</p> <p>ATTENTION: if P682 = 3 (peer to peer protocol) a maximum of 5 words (i001 to i005) can be transferred</p> <p>Type=O2; PKW: 1HEX=1.0 PcD Gr.: 0</p>	0 to 999	16 i001=0 i002=0 i003=0 i004=0 i005=0 i006=0 i007=0 i008=0 i009=0 i010=0 i011=0 i012=0 i013=0 i014=0 i015=0 i016=0	3 / BR 3 / BR
P692 * 2B4Hex	<p>ResPonseTLGfail</p> <p>Defines how the unit responds when a telegram fails.</p> <p>Parameter values: 0: Immediate fault trip 1: OFF3 (fast stop) and subsequent fault trip</p> <p>Note: This parameter is valid for all interfaces, where a telegram monitoring time is defined (SST1, CB/TB, SCB, SST2)</p> <p>Condition: The particular program monitoring time must be active. (P687 or P695 > 0)</p> <p>Type=O2; PKW: 1HEX=1.0 PcD Gr.: 0</p>	0 to 1 Fault OFF3(fast stop)	-	3 / BR 3 / BR
P694 * 2B6Hex	<p>CB/TB Act Values</p> <p>Output of analog values via CB or TB</p> <p>defines, which parameter is to be transferred at which telegram address.</p> <p>Notes: • Word 1 should be set for status word 1 (r968) • For double word parameters (type I4) the related parameter number must be entered at two subsequent words; otherwise only the most significant word will be transferred</p> <p>Indices: i001 = W01: Word 01 of the (process data part of the) telegram i002 = W02: Word 02 of the (process data part of the) telegram ... i016 = W16: Word 16 of the (process data part of the) telegram</p> <p>Type=O2; PKW: 1HEX=1.0 PcD Gr.: 0</p>	0 to 999	16 i001=968 i002=0 i003=0 i004=0 i005=0 i006=0 i007=0 i008=0 i009=0 i010=0 i011=0 i012=0 i013=0 i014=0 i015=0 i016=0	3 / BR 3 / BR

SW V1.3

PNU	Parameter Name in OP1	Range [Unit]	# of. Indices	read: write:
*:conf-P	Description	Value texts	Factory Settings.	
P695 * 2B7Hex	CB/TB TlgOFFTime Telegram lag time of CB and TB If no correct telegram is received within the parameterized time a fault trip is set. Description for setting: Value 0: no monitoring, no fault trip; must be parameterized for sporadic (non-cyclic) telegrams, e. g. operator panel OP at serial comm. interface 1. Type=O2; PKW: 1HEX=1.0ms PcD: 4000HEX=1638.4ms	0 to 6500 [ms]	- 10	3 / BR 3 / BR
P696 2B8Hex	CB Parameter 1 Communication Board parameter 1; see manual of the used communication board Description for setting: <ul style="list-style-type: none"> Parameter is only needed if a communication board is reported (P090 or P091 = 1) The communication board checks, if the set value is valid. If the value is not accepted, the fault message 80 is issued with fault value 5 Type=O2; PKW: 1HEX=1.0 PcD Gr.: 0	0 to 65535	- 0	3 / H BR 3 / H
P697 2B9Hex	CB Parameter 2 Communication Board parameter 2; refer to P696 Type=O2; PKW: 1HEX=1.0 PcD Gr.: 0	0 to 65535	- 0	3 / H BR 3 / H
P698 2BAHex	CB Parameter 3 Communication Board parameter 3; refer to P696 Type=O2; PKW: 1HEX=1.0 PcD Gr.: 0	0 to 65535	- 0	3 / H BR 3 / H
P699 2BBHex	CB Parameter 4 Communication Board parameter 4; refer to P696 Type=O2; PKW: 1HEX=1.0 PcD Gr.: 0	0 to 65535	- 0	3 / H BR 3 / H
P700 2BCHex	CB Parameter 5 Communication Board parameter 5; refer to P696 Type=O2; PKW: 1HEX=1.0 PcD Gr.: 0	0 to 65535	- 0	3 / H BR 3 / H
P701 2BDHex	CB Parameter 6 Communication Board parameter 6; refer to P696 Type=O2; PKW: 1HEX=1.0 PcD Gr.: 0	0 to 65535	- 0	3 / H BR 3 / H
P702 2BEHex	CB Parameter 7 Communication Board parameter 7; refer to P696 Type=O2; PKW: 1HEX=1.0 PcD Gr.: 0	0 to 65535	- 0	3 / H BR 3 / H
P703 2BFHex	CB Parameter 8 Communication Board parameter 8; refer to P696 Type=O2; PKW: 1HEX=1.0 PcD Gr.: 0	0 to 65535	- 0	3 / H BR 3 / H
P704 2C0Hex	CB Parameter 9 Communication Board parameter 9; refer to P696 Type=O2; PKW: 1HEX=1.0 PcD Gr.: 0	0 to 65535	- 0	3 / H BR 3 / H
P705 2C1Hex	CB Parameter 10 Communication Board parameter 10; refer to P696 Type=O2; PKW: 1HEX=1.0 PcD Gr.: 0	0 to 65535	- 0	3 / H BR 3 / H
P706 2C3Hex	CB Parameter 11 Communication Board parameter 11 Indices: i001 - i005 Refer to P696 Type=O2; PKW: 1HEX=1.0 PcD Gr.: 0	0 to 65535	5 i001=0 i002=0 i003=0 i004=0 i005=0	3 / H BR 3 / H

11.12 Diagnosis

PNU	Parameter Name in OP1	Range [Unit]	# of. Indices	read: / write: /
*:conf-P	Description	Value texts	Factory Settings.	
r720 2D0Hex	SW Version Software version of the PCBs in positions 1 to 3 of the electronic box. Indices: i001: Pos1: Software version of the PCB in position 1 (left) i002: Pos2: Software version of the PCB in position 2 (right) i003: Pos3: Software version of the PCB in position 3 (center) i004: Text: Software version of the text EPROM in position 1 i005: MWH: Software version CU sub-board MWH Note: The TSY board has no software code; the reported code is always '0.0' Type=O2; PKW: 1HEX=0.1 PcD Gr.: 0		5	3 / U BR
r721 2D1Hex	SW Generat.Date Software generation date of the CU board. Indices: i001= Year: CU Year i002= Mon.: CU Month i003= Day: CU Day i004= Y MW: MWH Year i005= M MW: MWH Month i006= D MW: MWH Day Type=O2; PKW: 1HEX=1.0 PcD Gr.: 0		6	3 / U BR
r722 2D2Hex	SW ID Expanded software version code of the PCBs in positions 1 to 3 of the electronic box (for factory use). Indices: i001: Pos1: Software code of the PCB in position 1 (left) i002: Pos2: Software code of the PCB in position 2 (right) i003: Pos3: Software code of the PCB in position 3 (center) i004: Text: Software code of the text EPROM in position 1 i005: MWH: Software code of the CU sub-board MWH Note: The TSY board has no software code; the reported code is always '0.0' Type=O2; PKW: 1HEX=0.1 PcD Gr.: 0		5	3 / U BR
r723 2D3Hex	PCB Code Identification code of the PCBs in positions 1 to 3 of the electronic box. Indices: i001: Pos1: PCB code of the PCB in position 1 (left) i002: Pos2: PCB code of the PCB in position 2 (right) i003: Pos3: PCB code of the PCB in position 3 (center) PCB codes: CU: 100 - 109 CB: 140 - 149 TB: 130 - 139 SCB: 120 - 129 TSY: 110 - 119 Type=O2; PKW: 1HEX=1.0 PcD Gr.: 0		3	3 / U BR
r725 2D5Hex	CalcTimeHeadroom Calculation time headroom of the CU board CPU in % of the computing power; influenced by sampling time (P308) and pulse frequency (P761) (not vor VC), as well as the number activated unit functions. Analog Output: 100% @ Parameter Value=16384% Type=O2; PKW: 1HEX=1.0% PcD Gr.: 0	[%]	-	3 / BR

PNU	Parameter Name in OP1	Range [Unit]	# of. Indices	read: write:
*:conf-P	Description	Value texts	Factory Settings.	/ /
r730 2DAHex	<p>SCB Diagnosis</p> <p>SCB diagnosis (all values in HEX display). Displayed numbers have an overflow at FF. The meaning of several Indices depends of the selected SCB protocol (P682).</p> <p>Indices:</p> <p>i001: fITC Number of error-free telegrams i002: Terr Number of error telegrams i003: Voff USS: Number of Byte-Frame-errors SCI boards: number of slave power outages i004: Toff USS: Number of Overrun-errors SCI boards: number of fiber optic link interrupts i005: PnoS USS: Parity error SCI boards: number of missing answer telegrams i006: STxL USS: STX-error SCI boards: number of search telegrams to accept a slave i007: ETX ETX-error i008: BcCC USS: Block-Check-error SCI boards: number of configuration telegrams i009: L/Te USS/Peer to Peer: incorrect telegram length SCI modules: required maximum number of terminals according to process data wiring (P554 to P631) i010: T/An USS: Timeout SCI modules: required analog inputs / outputs according to process data wiring of the setpoint channel and actual value output via SCI (P664) . i011: Res1 Reserve i012: Res2 Reserve i013: Warn SCB/DPR warning word i014: SI1? Information, if slave 1 needed and if yes, which type 0: no slave 1 needed 1: SCI1 2: SCI2 i015: SI2? Information, if slave 2 needed and if yes, which type 0: no slave 2 needed 1: SCI1 2: SCI2 i016: IniF: with 'SCI modules': initialization fault Type=L2; PKW: 1HEX=1.0 PcD Gr.: 0</p>		16	3 / H BR
r731 2DBHex	<p>CB/TB Diagnosis</p> <p>For detailed information see manuals of the used communication or technology boards. Type=L2; PKW: 1HEX=1.0 PcD Gr.: 0</p>		32	3 / H BR
P733 * 2DDHex	<p>Simulated Operat</p> <p>Simulated operation, allows test operation of the drive with de-energized DC bus. Parameter values: 0: no simulated operation 1: simulated operation</p> <p>Conditions:</p> <ul style="list-style-type: none"> • 24 V auxiliary power supply must be provided • Drive must be connected to the mains via a main contactor, which is driven by the drive (see P612) <p>Note: Simulated operation can only be selected, when the DC bus voltage (r006) is less than 5% of the rated DC bus voltage Type=O2; PKW: 1HEX=1.0 PcD Gr.: -</p>	0 to 1 off on	- 0	3 / BR 3 / B

PNU *:conf-P	Parameter Name in OP1 Description	Range [Unit] Value texts	# of. Indices Factory Settings.	read: <input type="checkbox"/> / <input type="checkbox"/> write: <input type="checkbox"/> / <input type="checkbox"/>
P735 * 2DFHex	Trace TriggerPar Parameter number of the signal which is to trigger the trace function; this function is realized with 8 channels. The tracer (TRC) is used to trace drive converter quantities from all up to a specific event. The trigger event is defined in P735 to P737. The quantity, which is to be traced, is defined in P738 and P739. Indices: i001 = Cha1: parameter number of the trigger signal, channel 1 i002 = Cha2: parameter number of the trigger signal, channel 2 i003 = Cha3: parameter number of the trigger signal, channel 3 i004 = Cha4: parameter number of the trigger signal, channel 4 i005 = Cha5: parameter number of the trigger signal, channel 5 i006 = Cha6: parameter number of the trigger signal, channel 6 i007 = Cha7: parameter number of the trigger signal, channel 7 i008 = Cha8: parameter number of the trigger signal, channel 8 Type=O2; PKW: 1HEX=1.0 PcD Gr.: 0	0 to 999	8 i001=0 i002=0 i003=0 i004=0 i005=0 i006=0 i007=0 i008=0	3 / BR 3 / BR
P736 * 2E0Hex	Trace Trig.Value Parameter value for the trigger condition. Parameter value of the trigger signal which will start or stop the trace function. Indices: i001 = Cha1: parameter value of the trigger signal, channel 1 i002 = Cha2: parameter value of the trigger signal, channel 2 i003 = Cha3: parameter value of the trigger signal, channel 3 i004 = Cha4: parameter value of the trigger signal, channel 4 i005 = Cha5: parameter value of the trigger signal, channel 5 i006 = Cha6: parameter value of the trigger signal, channel 6 i007 = Cha7: parameter value of the trigger signal, channel 7 i008 = Cha8: parameter value of the trigger signal, channel 8 Type=O2; PKW: 1HEX=1.0 PcD Gr.: 0	0 to 65535	8 i001=0 i002=0 i003=0 i004=0 i005=0 i006=0 i007=0 i008=0	3 / BR 3 / BR
P737 * 2E1Hex	Trace Trig.Cond. Trigger condition for the trace function. Parameter values: 0: Trigger, when the value of the trigger parameter is < 736.x 1: Trigger, when the value of the trigger parameter is = 736.x 2: Trigger, when the value of the trigger parameter is > 736.x 3: Trigger with a fault trip 4: Trigger, when the value of the trigger parameter is <> 736.x Indices: i001 = Cha1: trigger condition for channel 1 i002 = Cha2: trigger condition for channel 2 i003 = Cha3: trigger condition for channel 3 i004 = Cha4: trigger condition for channel 4 i005 = Cha5: trigger condition for channel 5 i006 = Cha6: trigger condition for channel 6 i007 = Cha7: trigger condition for channel 7 i008 = Cha8: trigger condition for channel 8 Type=O2; PKW: 1HEX=1.0 PcD Gr.: -	0 to 4 TRC < TRC == TRC > TRC fault TRC <>	8 i001=0 i002=0 i003=0 i004=0 i005=0 i006=0 i007=0 i008=0	3 / BR 3 / BR
P738 * 2E2Hex	Trace Act.Values Parameter number of the signal, which is to be recorded by the trace function Indices: i001 = Cha1: trace parameter channel 1 i002 = Cha2: trace parameter channel 2 i003 = Cha3: trace parameter channel 3 i004 = Cha4: trace parameter channel 4 i005 = Cha5: trace parameter channel 5 i006 = Cha6: trace parameter channel 6 i007 = Cha7: trace parameter channel 7 i008 = Cha8: trace parameter channel 8 Type=O2; PKW: 1HEX=1.0 PcD Gr.: 0	0 to 999	8 i001=0 i002=0 i003=0 i004=0 i005=0 i006=0 i007=0 i008=0	3 / BR 3 / BR

PNU	Parameter Name in OP1	Range [Unit]	# of. Indices	read: write:
*:conf-P	Description	Value texts	Factory Settings.	/ /
P739 * 2E3Hex	Trace SamPl.Time Sampling time for recording the trace values in multiples of the base sampling time (P308). Description for Setting: the sampling time is P739 * P308 Indices: i001 = Cha1: sampling time channel 1 i002 = Cha2: sampling time channel 2 i003 = Cha3: sampling time channel 3 i004 = Cha4: sampling time channel 4 i005 = Cha5: sampling time channel 5 i006 = Cha6: sampling time channel 6 i007 = Cha7: sampling time channel 7 i008 = Cha8: sampling time channel 8 Type=O2; PKW: 1HEX=1.0 PcD Gr.: -	1 to 200	8 i001=1 i002=1 i003=1 i004=1 i005=1 i006=1 i007=1 i008=1	3 / BR 3 / BR
P740 * 2E4Hex	Trace Pretrigger Defines the number of data recorded before and after the trigger condition. Example: a value of 40% means, that 40% of the data have been recorded before and 60% after the trigger condition. Indices: i001 = Cha1: sampling time channel 1 i002 = Cha2: sampling time channel 2 i003 = Cha3: sampling time channel 3 i004 = Cha4: sampling time channel 4 i005 = Cha5: sampling time channel 5 i006 = Cha6: sampling time channel 6 i007 = Cha7: sampling time channel 7 i008 = Cha8: sampling time channel 8 Type=O2; PKW: 1HEX=1.0% PcD Gr.: -	0 to 100 [%]	8 i001=0 i002=0 i003=0 i004=0 i005=0 i006=0 i007=0 i008=0	3 / BR 3 / BR
P741 * 2E5Hex	TRC Start Start command for trace function. A trace channel can only be started after completion of setting of ots parameters (P735 to P740 must have valid values). After the trace recording has been finished, the parameter is automatically reset. Parameter values: 0: trace channel stopped 1: trace channel has started Indices: i001 = Cha1: start channel 1 i002 = Cha2: start channel 2 i003 = Cha3: start channel 3 i004 = Cha4: start channel 4 i005 = Cha5: start channel 5 i006 = Cha6: start channel 6 i007 = Cha7: start channel 7 i008 = Cha8: start channel 8 Type=O2; PKW: 1HEX=1.0 PcD Gr.: -	0 to 1	8 i001=0 i002=0 i003=0 i004=0 i005=0 i006=0 i007=0 i008=0	3 / BR 3 / BR
r743 2E7Hex	Fault n/f(act) Frequency / speed actual value (r218) at time of tripping Type=l2; PKW: 1HEX=0.1Hz PcD Gr.: 1	[Hz]	-	2 / BR
r744 2E8Hex	Fault dn/dt Change of frequency / speed per sec at time of tripping Type=l2; PKW: 1HEX=0.01Hz PcD: 4000HEX=163.84Hz	[Hz]	-	2 / BR
r745 2E9Hex	Fault Isq(act) Actual value of the torque generating current component (r264) at time of tripping Type=l2; PKW: 1HEX=0.1A PcD Gr.: 2	[A]	-	2 / BR
r746 2EAHex	Fault Out Volts Actual value of the drive output voltage (r003) at time of tripping Type=O2; PKW: 1HEX=0.1V PcD Gr.: 3	[V]	-	2 / BR

PNU	Parameter Name in OP1	Range [Unit]	# of. Indices	read: <input type="checkbox"/> write: <input type="checkbox"/>
*:conf-P	Description	Value texts	Factory Settings.	
r747 2EBHex	Fault CtrlStatus Status of the control circuit (r150) at time of tripping Type=V2; PKW: 1HEX=1.0 PcD Gr.: 0		-	2 / BR
r748 2ECHex	TriP Time Trip times (operating hour meter values, r013) Indices: Day Hours Seconds latest trip (1) i001=T1-d i002=T1-h i003=T1-s last reset trip(2) i004=T2-d i005=T2-h i006=T2-s (last+1) reset trip (3) i007=T3-d i008=T3-h i009=T3-s ... oldest saved trip (8) i022=T8-d i023=T8-h i024=T8-s Trip description by: r947 Fault number r949 Fault value r951 list of fault numbers P952 number of faults Type=O2; PKW: 1HEX=1.0 PcD Gr.: 0		24	2 / BR
P750 * 2EEHex	TRC Data Block Number of the trace data block for each trace channel, which can be read via r751 to r758. Indices: i001 = Cha1: data block number channel 1 i002 = Cha2: data block number channel 2 i003 = Cha3: data block number channel 3 i004 = Cha4: data block number channel 4 i005 = Cha5: data block number channel 5 i006 = Cha6: data block number channel 6 i007 = Cha7: data block number channel 7 i008 = Cha8: data block number channel 8 Type=O2; PKW: 1HEX=1.0 PcD Gr.: -	0 to 255	8 i001=0 i002=0 i003=0 i004=0 i005=0 i006=0 i007=0 i008=0	3 / BR 3 / BR
r751 2EFHex	TRC Data Ch 1 Displays the trace data of channel 1. The block number of the trace data is set in P750. If all data of an array are requested via an automation interface in one order, P750.1 is automatically increased by 1 during the output. This allows an optimized reading of trace data. Type=O2; PKW: 1HEX=1.0 PcD Gr.: 0		116	3 / BR 3 / BR
r752 2F0Hex	TRC Data Ch 2 Refer to r751 Type=O2; PKW: 1HEX=1.0 PcD Gr.: 0		116	3 / BR 3 / BR
r753 2F1Hex	TRC Data Ch 3 Refer to r751 Type=O2; PKW: 1HEX=1.0 PcD Gr.: 0		116	3 / BR 3 / BR
r754 2F2Hex	TRC Data Ch 4 Refer to r751 Type=O2; PKW: 1HEX=1.0 PcD Gr.: 0		116	3 / BR 3 / BR
r755 2F3ex	TRC Data Ch 5 Refer to r751 Type=O2; PKW: 1HEX=1.0 PcD Gr.: 0		116	3 / BR 3 / BR
r756 2F4Hex	TRC Data Ch 6 Refer to r751 Type=O2; PKW: 1HEX=1.0 PcD Gr.: 0		116	3 / BR 3 / BR
r757 2F5ex	TRC Data Ch 7 Refer to r751 Type=O2; PKW: 1HEX=1.0 PcD Gr.: 0		116	3 / BR 3 / BR
r758 2F6Hex	TRC Data Ch 8 Refer to r751 Type=O2; PKW: 1HEX=1.0 PcD Gr.: 0		116	3 / BR 3 / BR

11.13 Modulator

PNU	Parameter Name in OP1	Range [Unit]	# of. Indices	read: write:
*:conf-P	Description	Value texts	Factory Settings.	
P761 2F9Hex	<p>Pulse Frequency</p> <p>Pulse frequency at asynchronous space vector modulation</p> <p>Description for setting:</p> <p>The setting range of the pulse frequency depends of the type of the drive and of settings of the control circuit</p> <p>ATTENTION: if the pulse frequency is increased, the maximum current (P173) may be reduced. If afterwards the pulse frequency is reduced again, the value of P173 will not be changed back.</p> <p>Note: the setting range of this parameter is also influenced by P092 (output filter). For active noise damping (P762 > 0), the pulse frequency is limited to min. 45*rated motor frequency (P107), otherwise to 30*P107 and up to P107 = 104 Hz to 2.5 kHz.</p> <p>MDS(4) Parameter Type=O2; PKW: 1HEX=0.1kHz PcD: 4000HEX=16.384kHz</p>	1.5 to 16.0 [kHz]	4 i001=2.5 i002=2.5 i003=2.5 i004=2.5	3 / ABR 3 / A
P762 2FAHex	<p>SIMO Sound</p> <p>changes the noise characteristics of the motor; at low pulse frequencies this may result in a noise reduction</p> <p>As a result of increased harmonics, when this function is activated, a minimum pulse frequency P761 must be set to 45*rated motor frequency. Only then can SIMO-Sound be enabled.</p> <p>Description for setting:</p> <p>the motor noise is significantly influenced by mechanical oscillations of the drive system; for that reason several settings must be tested.</p> <p>Parameter values: 0: not active 1: sound steps 1 2: sound steps 2 3: sound steps 3 4: sound steps 4</p> <p>MDS(4) Parameter Type=O2; PKW: 1HEX=1.0 PcD Gr: -</p>	0 to 4 OFF Sound 1 Sound 2 Sound 3 Sound 4	4 i001=0 i002=0 i003=0 i004=0	3 / BR 3 / BR
P763 2FBHex	<p>Max ModulatDePth</p> <p>Maximum depth of modulation of the modulator; defines the maximum possible output voltage</p> <p>Description for Setting:</p> <ul style="list-style-type: none"> High output voltages can be reached by using the edge modulation mode at a high depth of modulation. Low parameter values prevent the change from space vector to edge modulation mode, the reachable output voltage is lower. The depth of modulation at the change from space vector to edge modulation mode depends of the type of the drive. Typical values @ 2.5 kHz are: for a rated drive current <= 186 A: about 87% for a rated drive current > 186 A: about 84%. The change to edge modulation can be prevented via P769. <p>Note: if a sine wave output filter is used (P092 = 1) the maximum depth of modulation is so far reduced, that the modulator only operates in space vector modulation mode. The effective modulation depth limit is displayed in P180.</p> <p>MDS(4) Parameter Type=O2; PKW: 1HEX=0.1% PcD: 4000HEX=400%</p>	20.0 to 96.0 [%]	4 i001=96.0 i002=96.0 i003=96.0 i004=96.0	3 / BR 3 / BR
r764 2FCHex	<p>Modulation DePth</p> <p>Depth of modulation of the modulator</p> <p>Analog Output: 100% @ Parameter Value=1638.4%</p> <p>Type=O2; PKW: 1HEX=0.1% PcD: 4000HEX=400%</p>	[%]	-	3 / BR

PNU	Parameter Name in OP1	Range [Unit]	# of. Indices	read: <input type="checkbox"/> write: <input type="checkbox"/>
*:conf-P	Description	Value texts	Factory Settings.	
P765 2FDHex	ModDePth Headrm Headroom of the depth of modulation Limit for the depth of modulation (r180) at steady state operation; at dynamic operation this limit may be exceeded up to the value of the maximum depth of modulation (r180). Related display parameter: r181 (maximum output voltage) MDS(4) Parameter Type=O2; PKW: 1HEX=0.1% PcD: 4000HEX=400%	0.0 to 10.0 [%]	4 i001=0.0 i002=0.0 i003=0.0 i004=0.0	3 / BR 3 / BR
P766 2FEHex	Dead Time Comp. Dead time compensation. Compensation time of the gating unit interlock Pre-set during automatic motor identification (P052 = 7, 8). Condition: P100 = 3 (motor type = sync.perm.) Setting instructions: <ul style="list-style-type: none"> For positioning drives or to improve the smooth running characteristics at low frequencies, it may be practical to disable the compensation (P770 = 0). In this case, it is not permissible that P766 is reset, in order that the missing compensation voltage can be internally calculated from it. (Only for P163 = 3, 4, 5 vector control types). To improve the smooth running characteristics for V/Hz modes (P163 = 0, 1, 2), the compensation of the interlock time can be changed. Type=O2 PKW: 1HEX=0.01µs PcD Gr.:0	0.00 to 25.55 [us]	- 1.50	3 / BR 3 / BR
P769 301Hex	ModSystemRelease Releases edge modulation systems. Parameter values: 0: all systems 1: edge modulation systems above 60 Hz 2: adge modulation systems above 100 Hz 3: no edge modulation systems MDS(4) Parameter Type=O2; PKW: 1HEX=1.0 PcD Gr.: -	0 to 3 all syst. FLM from 60 Hz FLM from 100 Hz no FLM	4 i001=0 i002=0 i003=0 i004=0	3 / ABR 3 / A
P770 302Hex	Deadtime comp. Selects the deadtime compensation in the gating unit. The deadtime compensation eliminates voltage errors, which are obtained by the interlock times in the gating unit. Compensation is enabled/disabled during automatic parameter setting (P052 = 6) and during automatic motor identification (P052 = 7, 8). Parameter values: 0: No deadtime compensation in the gating unit 1: Deadtime compensation enabled in the gating unit Setting instructions: <ul style="list-style-type: none"> For high pulse frequencies, for motors with low stator time constant (r274, positioning drives) and for long feeder cables, it may be practical to disable the compensation in order to improve the smooth running characteristics at low speeds. In order to compensate the steady-state error in the stator resistance, for vector control types (P163 = 3, 4, 5), an addition transistor voltage is automatically internally added. The current controller dynamic performance is simultaneously increased. For frequency control (P163 = 3), the resonant damping P300 could also be additionally reduced. Type=O2; PKW: 1HEX: = 0.01 µs PcD Gr.: 0	0 to 1 off on	- 1	3 / BR 3 / BR

11.14 Factory Parameters

PNU	Parameter Name in OP1	Range [Unit]	# of. Indices	read: / write: /
*:conf-P	Description	Value texts	Factory Settings.	
P791 317Hex	MWH RAM AccValue Value of the memory cell of the MWH software Type=L2; PKW: 1HEX=1.0 PcD Gr.: 0	0 to 65535	- 0	3 / BR 4 / BR
P799 * 31FHex	SPecial Access Parameter for special access Type=O2; PKW: 1HEX=1.0 PcD Gr.: 0	0 to 65535	- 0	3 / BR 3 / BR

11.15 Special Parameters

PNU	Parameter Name in OP1	Range [Unit]	# of. Indices	read: / write: /
*:conf-P	Description	Value texts	Factory Settings.	
P899 383Hex	OP setting Is used to set the drive converter address when several drive converters are controlled from one OP. Note: The parameter can only be displayed at the OP.		-	1 /UHABR 1 /UHABR

11.16 Profile Parameters

PNU	Parameter Name in OP1	Range [Unit]	# of. Indices	read: / write: /
*:conf-P	Description	Value texts	Factory Settings.	
P917 * 395Hex	<p>Change rePorts</p> <p>Defines the interfaces, where active parameters are reported if they are changed.</p> <p>Parameter values: 0: none 1: output via dual port RAM (TB, CB) 2: output via serial comm. interface 1 (SCom1) 4: output via SCB with USS protocol 8: Output via serial comm. interface 2 (SCom2)</p> <p>Description for setting: enter the total of the figures which are related to the interfaces, which are to issue the message.</p> <p>Type=V2; PKW: 1HEX=1.0 PcD Gr.: -</p>	0 to 15	- 0	3 / B 3 / B
P918 396Hex	<p>CB Bus Address</p> <p>Protocol depending bus address for communication boards; see manual of these boards</p> <p>Note: The communication board checks, if the set value is valid. If the value is not accepted, the fault message 80 is issued with fault value 5</p> <p>Condition: P090 = 1 or P091 = 1 (communication board installed)</p> <p>Type=O2; PKW: 1HEX=1.0 PcD Gr.: -</p>	0 to 126	- 3	3 / H BR 3 / H
P927 * 39FHex	<p>Parameter Access</p> <p>Release of interfaces for the parameterization; description see P053.</p> <p>Type=O2; PKW: 1HEX=1.0 PcD Gr.: -</p>	0 to 63	- 6	3 / BR 3 / BR
P928 * 3A0Hex	<p>Src Base/Reserve</p> <p>Source of the switching command 'base / reserve settings' (control word 2, bit 30); parameter is identical with P590 - description there</p> <p>Type=L2; PKW: PKW-Format(HEX)=Par Value PcD Gr.: 0</p>	0 to 6004	- 1005	3 / BR 3 / BR

PNU *:conf-P	Parameter Name in OP1 Description	Range [Unit] Value texts	# of. Indices Factory Settings.	read: write: / /																																																																											
<p>r947 3B3Hex</p>	<p>Fault Memory Display of the faults which have occurred at the last 8 trips (r748); at every trip up to 8 faults can be saved, related to each of them a fault number (see list of faults, chapter 7) is related. For text display of the faults see r951. Indices: <table border="0" style="width: 100%; border-collapse: collapse;"> <tr> <td></td> <td style="text-align: center;">Fault 1</td> <td style="text-align: center;">Fault 2</td> <td style="text-align: center;">...</td> <td style="text-align: center;">Fault 8</td> </tr> <tr> <td>latest trip (1)</td> <td style="text-align: center;">i001=F1-1</td> <td style="text-align: center;">i002=F1-2</td> <td style="text-align: center;">...</td> <td style="text-align: center;">i008=F1-8</td> </tr> <tr> <td>last reset trip (2)</td> <td style="text-align: center;">i009=F2-1</td> <td style="text-align: center;">i010=F2-2</td> <td style="text-align: center;">...</td> <td style="text-align: center;">i016=F2-8</td> </tr> <tr> <td>(last+1) reset trip (3)</td> <td style="text-align: center;">i017=F3-1</td> <td style="text-align: center;">i018=F3-2</td> <td style="text-align: center;">...</td> <td style="text-align: center;">i024=F3-8</td> </tr> <tr> <td>...</td> <td></td> <td></td> <td></td> <td></td> </tr> <tr> <td>oldest saved trip (8)</td> <td style="text-align: center;">i057=F8-1</td> <td style="text-align: center;">i058=F8-2</td> <td style="text-align: center;">...</td> <td style="text-align: center;">i064=F8-8</td> </tr> </table> Notes: A value of '0' means 'no fault' Number of saved trips: see P952. Example of a trip: last reset trip (2) <table border="0" style="width: 100%; border-collapse: collapse;"> <tr> <td style="text-align: center;">Index</td> <td style="text-align: center;">r947</td> <td style="text-align: center;">r949</td> <td style="text-align: center;">Index</td> <td style="text-align: center;">r748</td> </tr> <tr> <td style="text-align: center;">9</td> <td style="text-align: center;">35</td> <td style="text-align: center;">0</td> <td style="text-align: center;">4</td> <td style="text-align: center;">62</td> </tr> <tr> <td style="text-align: center;">10</td> <td style="text-align: center;">37</td> <td style="text-align: center;">2</td> <td style="text-align: center;">5</td> <td style="text-align: center;">1</td> </tr> <tr> <td style="text-align: center;">11</td> <td style="text-align: center;">0</td> <td style="text-align: center;">0</td> <td style="text-align: center;">6</td> <td style="text-align: center;">7</td> </tr> <tr> <td style="text-align: center;">12</td> <td></td> <td></td> <td></td> <td></td> </tr> <tr> <td style="text-align: center;">13</td> <td></td> <td></td> <td></td> <td></td> </tr> <tr> <td style="text-align: center;">14</td> <td></td> <td></td> <td></td> <td></td> </tr> <tr> <td style="text-align: center;">15</td> <td></td> <td></td> <td></td> <td></td> </tr> <tr> <td style="text-align: center;">16</td> <td></td> <td></td> <td></td> <td></td> </tr> </table> Trip time (r748): after 62 days, 1 hour, 7 sec of operation Faults (r947): 35 37 Fault value (r949): not defined 2 Type=O2; PKW: 1HEX=1.0 PcD Gr.: 0</p>		Fault 1	Fault 2	...	Fault 8	latest trip (1)	i001=F1-1	i002=F1-2	...	i008=F1-8	last reset trip (2)	i009=F2-1	i010=F2-2	...	i016=F2-8	(last+1) reset trip (3)	i017=F3-1	i018=F3-2	...	i024=F3-8	...					oldest saved trip (8)	i057=F8-1	i058=F8-2	...	i064=F8-8	Index	r947	r949	Index	r748	9	35	0	4	62	10	37	2	5	1	11	0	0	6	7	12					13					14					15					16						64	2 / BR
	Fault 1	Fault 2	...	Fault 8																																																																											
latest trip (1)	i001=F1-1	i002=F1-2	...	i008=F1-8																																																																											
last reset trip (2)	i009=F2-1	i010=F2-2	...	i016=F2-8																																																																											
(last+1) reset trip (3)	i017=F3-1	i018=F3-2	...	i024=F3-8																																																																											
...																																																																															
oldest saved trip (8)	i057=F8-1	i058=F8-2	...	i064=F8-8																																																																											
Index	r947	r949	Index	r748																																																																											
9	35	0	4	62																																																																											
10	37	2	5	1																																																																											
11	0	0	6	7																																																																											
12																																																																															
13																																																																															
14																																																																															
15																																																																															
16																																																																															
<p>r949 3B5Hex</p>	<p>Fault Value Fault values of the faults; allows a more detailed diagnosis at several faults. The fault values are saved in the same indices as the related fault numbers (r947) - see example at P947. Type=O2; PKW: 1HEX=1.0 PcD Gr.: 0</p>		64	3 / BR																																																																											
<p>r951 3B7Hex</p>	<p>Fault Texts List of fault texts; every fault text is saved in the index equivalent to its fault number. Example (see P947): Value of P947, i09 is '35'. The related fault was (P951, i35): 'Ext. Fault1'. Type=O2; PKW: 1HEX=1.0 PcD Gr.: 0</p>		116	2 / BR																																																																											
<p>P952 * 3B8Hex</p>	<p># of Faults Number of saved trips (max. 8). If the parameter is set to '0', the diagnosis memory (r748 - trip times, r947 - fault number, r949 fault value) is cleared. Type=O2; PKW: 1HEX=1.0 PcD Gr.: -</p>	0 to 8	- 0	2 / BR 2 / BR																																																																											
<p>r953 3B9Hex</p>	<p>Warning Param1 If a warning (numbers 1 to 16) is active, the related bar in the display is ON <table border="0" style="margin-left: auto; margin-right: auto;"> <tr> <td style="text-align: center;"> 16 </td> <td style="text-align: center;"> 14 </td> <td style="text-align: center;"> 12 </td> <td style="text-align: center;"> 10 </td> </tr> <tr> <td style="text-align: center;">15</td> <td style="text-align: center;">13</td> <td style="text-align: center;">11</td> <td style="text-align: center;">9</td> </tr> <tr> <td style="text-align: center;"> 8 </td> <td style="text-align: center;"> 6 </td> <td style="text-align: center;"> 4 </td> <td style="text-align: center;"> 2 </td> </tr> <tr> <td style="text-align: center;">7</td> <td style="text-align: center;">5</td> <td style="text-align: center;">3</td> <td style="text-align: center;">1</td> </tr> </table> Type=V2; PKW: 1HEX=1.0 PcD Gr.: 0</p>	16	14	12	10	15	13	11	9	8	6	4	2	7	5	3	1		-	3 / BR																																																											
16	14	12	10																																																																												
15	13	11	9																																																																												
8	6	4	2																																																																												
7	5	3	1																																																																												

PNU	Parameter Name in OP1	Range [Unit]	# of. Indices	read: <input type="checkbox"/> write: <input type="checkbox"/>
*:conf-P	Description	Value texts	Factory Settings.	
r954 3BAHex	Warning Param2 If a warning (numbers 17 to 32) is active, the related bar in the display is ON  Type=V2; PKW: 1HEX=1.0 PcD Gr.: 0		-	3 / BR
r955 3BBHex	Warning Param3 If a warning (numbers 33 to 48) is active, the related bar in the display is ON  Type=V2; PKW: 1HEX=1.0 PcD Gr.: 0		-	3 / BR
r956 3BCHex	Warning Param4 If a warning (numbers 49 to 64) is active, the related bar in the display is ON  Type=V2; PKW: 1HEX=1.0 PcD Gr.: 0		-	3 / BR
r957 3BDHex	Warning Param5 If a warning (numbers 65 to 80) is active, the related bar in the display is ON  Type=V2; PKW: 1HEX=1.0 PcD Gr.: 0		-	3 / BR
r958 3BEHex	Warning Param6 If a warning (numbers 81 to 96) is active, the related bar in the display is ON  Type=V2; PKW: 1HEX=1.0 PcD Gr.: 0		-	3 / BR
r959 3BFHex	Warning Param7 If a warning (numbers 97 to 112) is active, the related bar in the display is ON  Type=V2; PKW: 1HEX=1.0 PcD Gr.: 0		-	3 / BR
r960 3C0Hex	Warning Param8 If a warning (numbers 113 to 128) is active, the related bar in the display is ON  Type=V2; PKW: 1HEX=1.0 PcD Gr.: 0		-	3 / BR

PNU	Parameter Name in OP1	Range [Unit]	# of. Indices	read: write:
*:conf-P	Description	Value texts	Factory Settings.	
r964	Drive ID Drive ID 3C4Hex Text string; contains information about the ID# (first 2 bytes of the string, used to identify the drive by Profibus) and about the drive type name (last 24 bytes of the string, used for display in visualization systems). A further 24 characters contain the software release and the date the software was generated Parameter values: 2 Bytes: ID#: 8022Hex 24 Byte: model name according to the drive type: MASTER DRIVES VC 24 Byte: Software release and date that the software was generated V1.3 day.month.year Note: The parameter cannot be selected at the PMU; for OP, the value cannot be displayed. Type=VS; PKW: 1HEX=1.0 PcD Gr.: 0		-	3/ BR
r965	Profile # PROFIBUS specific parameter 3C5Hex Note: The parameter cannot be selected at the PMU; for OP, the value cannot be displayed. Type=OS; PKW: 1HEX=1.0 PcD Gr.: 0		-	3/ BR
r967	Control Word 1 Display parameter of control word 1 (bit 0-15) 3C7Hex Identical with r550 (control word 1) Type=V2; PKW: 1HEX=1.0 PcD Gr.: 0		-	2/ BR
r968	Status Word 1 Display parameter of status word 1 (bit 0 - 15) 3C8Hex Identical with r552 (status word 1) Type=V2; PKW: 1HEX=1.0 PcD Gr.: 0		-	2/ BR
P970	Factory Settings * Parameter reset to factory settings 3CAHex Parameter values: 0: Parameter reset: all parameters are reset to their original values (factory settings); after this the parameter is reset to '1'. 1: no parameter reset Note: This function can also be selected via P052=1. Type=O2; PKW: 1HEX=1.0 PcD Gr.: -	0 to 1	- 1	3/ B 3/ B
P971	EEPROM Saving * Saves parameter values in the EEPROM with a transition of the parameter value from 0 to 1. 3CBHex The parameter must be manually reset to '0'. Parameter values: 0: no saving of parameter values 1: a transition from 0 to 1 saves the RAM values to the EEPROM Type=O2; PKW: 1HEX=1.0 PcD Gr.: -	0 to 1	- 0	3/ BR 3/ BR
r980	Par # List Pt1 List of the available parameter numbers; part 1 3D4Hex The parameter numbers are listed in a positive sequence. The first existing '0' shows, that no more parameter numbers are available. Index range: 1 to 116. As special function the value of i116 is the number of the parameter which contains the next following part of the list. If i116 has a value of '0' then there are no more parts of the list. Type=O2; PKW: 1HEX=1.0 PcD Gr.: 0		116	3/ BR

PNU	Parameter Name in OP1	Range [Unit]	# of. Indices	read: / write: /
*:conf-P	Description	Value texts	Factory Settings.	
r981 3D5Hex	Par # List Pt2 List of the available parameter numbers; part 2; see r980. Type=O2; PKW: 1HEX=1.0 PcD Gr.: 0		116	3 / BR
r982 3D6Hex	Par # List Pt3 List of the available parameter numbers; part 3; see r980. Type=O2; PKW: 1HEX=1.0 PcD Gr.: 0		116	3 / BR
r983 3D7Hex	Par # List Pt4 List of the available parameter numbers; part 4; see r980. Type=O2; PKW: 1HEX=1.0 PcD Gr.: 0		116	3 / BR
r984 3D8Hex	Par # List Pt5 List of the available parameter numbers; part 5; see r980. Type=O2; PKW: 1HEX=1.0 PcD Gr.: 0		116	3 / BR
r985 3D9Hex	Par # List Pt6 List of the available parameter numbers; part 6; see r980. Type=O2; PKW: 1HEX=1.0 PcD Gr.: 0		116	3 / BR
r986 3DAHHex	Par # List Pt7 List of the available parameter numbers; part 7; see r980. Type=O2; PKW: 1HEX=1.0 PcD Gr.: 0		116	3 / BR
r987 3DBHex	Par # List Pt8 List of the available parameter numbers; part 8; see r980. Type=O2; PKW: 1HEX=1.0 PcD Gr.: 0		116	3 / BR
r988 3DCHex	Par # List Pt9 List of the available parameter numbers; part 9; see r980. Type=O2; PKW: 1HEX=1.0 PcD Gr.: 0		116	3 / BR
r989 3DDHex	Par # List Pt10 List of the available parameter numbers; part 10; see r980. Type=O2; PKW: 1HEX=1.0 PcD Gr.: 0		116	3 / BR
r990 3DEHex	Par # List chg1 List of the changed parameters; part 1 The parameter numbers are listed in a positive sequence. The first existing '0' shows, that no more parameter numbers are available. Index range: 1 to 116. As special function the value of i116 is the number of the parameter which contains the next following part of the list. If i116 has a value of '0' then there are no more parts of the list. Type=O2; PKW: 1HEX=1.0 PcD Gr.: 0		116	3 / BR
r991 3DFHex	Par # List chg2 List of the changed parameters; part 2; see r990. Type=O2; PKW: 1HEX=1.0 PcD Gr.: 0		116	3 / BR
r992 3E0Hex	Par # List chg3 List of the changed parameters; part 3; see r990. Type=O2; PKW: 1HEX=1.0 PcD Gr.: 0	116	116	3 / BR

12 Fault and alarm messages

12.1 Fault messages

For each fault the following information is available:

Parameter	r947	Fault number
	r949	Fault value
	r951	Fault list
	P952	Number of faults
	r748	Fault time

If a fault code is not reset before the electronic supply is switched off, then the fault code will be present again, when the electronic supply is switched on again. The unit cannot be operated without resetting the fault message. (Exception: Automatic restart has been selected, see P366).

Fault messages		Counter measures
No.	Fault description	
F001	Contact. chckbck. If a main contactor checkback signal is configured, a checkback signal was not received within 500 ms after the power-up command.	P591 S.MC chckbck. sign., The parameter value must match the main contactor checkback signal connection. Check the main contactor checkback signal circuit. ☞ Section "Connecting-up" in the Operating Instructions, Part 1.
F002	Pre-charging When pre-charging, the minimum DC link voltage (P071 Conv. supply voltage * 1.34) of 80 % was not reached. The maximum pre-charging time of 3 s was exceeded.	Check the supply voltage, Compare with P071 Conv. supply volt..
F006	DC link overvoltage The unit was shutdown due to an excessive DC link voltage. <u>Supply voltage - DC voltage range Shutdown threshold</u> 208 V - 230 V 280 V - 310 V 412 V 380 V - 460 V 510 V - 620 V 819 V 500 V - 575 V 675 V - 780 V 1022 V 660 V - 690 V 890 V - 930 V 1220 V • inverters connected in parallel (Size L) r949 = 1: overvoltage in the DC link of the master r949 = 2: overvoltage in the DC link of the slave.	Check the supply voltage or the input DC voltage The converter operates in the regenerative mode without regenerative possibility. If the converter supply voltage is at the upper tolerance limit and it is operating under full load conditions, F006 can also be initiated when a line phase fails. Possibly; • P464 increase deceleration time, • P377 activate the V(d,max)-Controller (first check P071) • P370 decrease the speed catch speed. • P233 Pw(gen, max) to be decreased (only with P163 = 3, 4 or 5)
F008	DC link uvolt. The lower limit of 76 % of the DC link voltage (P071 Line Volts * 1.34) was fallen below. For enabled kinetic buffering, 61 %. DC link undervoltage in 'standard' operation (i.e. no SIMULATION). DC link undervoltage with active kinetic buffering and speed less than 10 % of the rated motor speed. It was a 'brief supply failure' which was only detected after the supply returned (WEA-flag).	Check • the supply voltage P071 Line Volts • of the input rectifier • of the DC link
F011	Overcurrent The unit was shutdown due to an overcurrent condition. The shutdown threshold was exceeded,	Check • the converter-output for short-circuit or ground fault • the load for an overload condition • whether the motor and converter are correctly matched • whether the dynamic requirements are too high.



		Fault messages	
No.	Fault description		Counter measures
F012	I too low While the motor was being energized, the current did not rise i(sd,partial load)/8	Only for closed-loop-n/ f/ m control! If a motor is not connected; go into the simulation mode and check P733 Simulation operation , current sensing. Check the power section	
F015	Motor stall. Motor has stalled or is locked: <ul style="list-style-type: none"> • by the ramp up or down time being too fast, the load change was for faster too great • the static load is too high • by a fault in the parameter for the pulse tacho pulse count P209 or in the scaling of the analog tacho P210. The fault is only generated after the time set in P520. To see if the drive is stalled or has pulled out, see P517 (actual-setpoint difference) and P518. With V/f-control the I(max)-control must be activated (P175). With n/f-control the torque limit (r150 bit7, bit8) or the internal frequency limit (r150 bit4) must be reached before this fault is activated. In the statusword of the control (r150), bit 15 will be set. Not valid with V/f-textile (P163 = 2) control.	<ul style="list-style-type: none"> • reduce the load • release the brake • increase the current limit • increase P520 stall time • increase the threshold for setpoint-actual comparator P517 <ul style="list-style-type: none"> ◆ only f/n/M-control (P163 = 3, 4, 5) <ul style="list-style-type: none"> • increase torque limits or the torque setpoint ◆ only n/M-control or V/f-control with speed loop: (P163 = 0, 4, 5) <ul style="list-style-type: none"> • check tacho feedback cables • check pulse tacho pulse count • check the scaling of the analog tacho • reduce the smoothing of the speed pre-control P216 (only n/M control) ◆ only f-control: (P163 = 3) <ul style="list-style-type: none"> • slow down the acceleration time (also P467) • increase current in the bottom of the frequency range (P202, P203, P204) • switch in the speed controller pre-control (P243>0) • set the EMF controller more dynamically to max. approx. 2 (P287,P289) • increase the threshold frequency for the EMF controller (P284) • substitute for n-control with pulse tacho feedback ◆ only M-control (P163 = 5) or following drive: <ul style="list-style-type: none"> • feed the speed setpoint together with the speed feedback so that the setpoint-actual difference is always smaller than set at P517. 	
F017	Motor not found Motor was not found (for restart on the fly with tachometer).	Power-up - after coast down. If required, increase P369, Restart search current	
F018	F set restart The found set-frequency was not able to be implemented, as the supplementary setpoint is too high.	Check the supplementary setpoint. Power-up after the motor has coasted to a stop.	
F020	Motor temp. The motor limiting temperature has been exceeded. r949 = 1 Motor temperature limit exceeded r949 = 2 short circuit in the cable to the temperature sensor or sensor defect r949 = 3 open circuit in the cable to the temperature sensor or sensor defect	Check the motor (load, ventilation, etc.). The actual motor temperature can be read in r009 Motor_temp . Check P361 Mot Tmp Fault Check the KTY84-input at connector -X103:41,42 for short-circuit or wire breakage.	
F021	Motor I2t Parameterized limit value of the I ² t-monitoring for the motor was exceeded.	Check: P363 Mot. temp.T1	



No.	Fault messages	
	Fault description	Counter measures
F023	<p>Inverter temp. The temperature limit of the inverter has been exceeded.</p> <p>r949 = 1 The temperature limit of the inverter has been exceeded.</p> <p>r949 = 2 Sensor 1: Wire break in the sensor wire or sensor is defect</p> <p>r949 = 18 Sensor 2: Wire break in the sensor wire or sensor is defect</p> <p>r949 = 34 Sensor 3: Wire break in the sensor wire or sensor is defect</p> <p>r949 = 50 Sensor 4: Wire break in the sensor wire or sensor is defect</p>	<p>Measure the air intake and ambient temperature. Please observe the derating curves" for $\vartheta > 40$ °C.  Section "Technical data" in the Instruction Manual, Part 1</p> <p>Check;</p> <ul style="list-style-type: none"> whether fan -E1 is connected and is rotating in the correct direction. that the air entry and discharge openings are not restricted. temperature sensor at -X30
F025	<p>UCE ph. L1 There was an UCE shutdown in phase L1.</p>	<p>Check;</p> <ul style="list-style-type: none"> phase L1 for short-circuit or ground fault (-X2:U2 including motor). that the CU is correctly inserted.
F026	<p>UCE ph. L2 There was an UCE shutdown in phase L2.</p>	<p>Check;</p> <ul style="list-style-type: none"> phase L2 for short-circuit or ground fault (-X2:V2 including motor). that the CU is correctly inserted.
F027	<p>UCE ph. L3 There was an UCE-shutdown in phase L3.</p>	<p>Check;</p> <ul style="list-style-type: none"> phase L3 for short circuit or ground fault. (-X2:W2 -including motor). that the CU is correctly inserted.
F028	<p>Supply phase The frequency and amplitude of the DC link ripple indicates a single phase supply failure.</p>	<p>Check the supply voltage</p>
F029	<p>Meas. val. sens. The measured value sensing system has developed a fault.</p> <ul style="list-style-type: none"> (r949 = 1) Offset adjustment not possible in phase L1. (r949 = 2) Offset adjustment not possible in phase L3. (r949 = 3) Offset adjustment not possible in phases L1 and L3. (r949=65) The analog inputs cannot be automatically adjusted 	<p>Defective measured value sensing Defective phase section (valve cannot block). Defective CU</p>
F035	<p>Ext. fault1 External fault 1 input, which can be parameterized, was activated.</p>	<p>Check;</p> <ul style="list-style-type: none"> if there is an external fault if the cable to the appropriate binary input is interrupted P575 S k fault ext.1 <p> Section "Binary inputs" in the Operating Instructions, Part 2</p>
F036	<p>Ext. fault2 External fault 2 input, which can be parameterized, was activated.</p>	<p>Check;</p> <ul style="list-style-type: none"> if there is an external fault if the cable to the appropriate binary input is interrupted P586 S.k. fault ext. 1 <p> Section „Binary inputs“ in the Operating Instructions, Part 2</p>
F037	<p>Analog input.</p>	<p>Check the connection to</p> <ul style="list-style-type: none"> analog input -X102:27, 28, 29. analog input 2 -X102:30 ,31, 32. <p>check parameters</p> <ul style="list-style-type: none"> P650 CU-AE configuration P651 CU-AE smoothing P652 CU-AE offset <p> Section "Control terminal strip and serial interface" in the Operating Instructions, Part 2</p>

No.	Fault description	Fault messages	
			Counter measures
F040	AS internal Incorrect operating status.		Replace the CU board (-A10)
F041	EEprom fault A fault occurred when storing the values in the EEPROM.		Replace the CU board (-A10)
F042	Comp. time Computation time problems		Reduce computation time load, increase sampling time P308 observe r725 , free comp time
F043	Coupling int. Internal coupling error. One of the two coupling partners does not respond		Replace CU2 board (-A10) Check MWH - CU2 connection
F044	Parcoupl.int Error in the internal parameter coupling		Compare MWH software and CU2 software releases regarding the transfer parameters. Replace the CU board (-A10).
F045	Opt.brd HW A hardware fault occurred when accessing the option board		Replace CU Check the connection between the subrack and option boards
F046	Par. con.		Power the converter off and up again. Replace CU board (-A10).
F047	Int. comp. time		Replace CU board (-A10).
F048	Int. pulse fr.		Change P761 pulse frequency .
F049	SW release The EPROMs on the CU have different software releases. The language EPROM is compared with the CU software as well as the MWH software with the CU software.		<ul style="list-style-type: none"> • Replace language PROM • Replace MWH EPROM
F050	TSY init. Error when initializing the TSY board		Check; <ul style="list-style-type: none"> • is the TSY board correctly inserted • does the parameter setting coincide with the boards used P090 board, slot 2 - P091 board, slot 3 r723 board code - 724 board ID
F051	Speed encod. Digital tachometer or analog tachometer sensing are faulted.		Check parameters; <ul style="list-style-type: none"> • P208 S. speed act. val., • P209 pulse number, • P210 an. tach. norm. • P109 mot. pole pair no. The product of P109 and P210 must be less than 19200. Check or replace the tachometer; or check the connection to the tachometer. Replace CU. ☞ Also refer to Instruction Manual 6SE70876X84-3DF0 analog tachometer interface or 6SE70876X84-3DA0 digital tachometer interface
F052	n-cntr. input The fault input on the TSY board was active.		Cancel tachometer with control track P208 S. speed act. val. Replace TSY. Check the tacho connection at the TSY board. Depending on the tacho type, several versions are possible, ☞ Also refer to the Instruction Manual 6SE7097-6CX84-0BA0 tachometer- and synchronizing board.

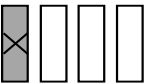

Fault messages		
No.	Fault description	Counter measures
F053	Tacho dn/dt The permissible change value of the speed encoder signal P215 dn(actual, permissible) was exceeded.	Check the tacho feeder cables to ensure that they are intact. Check the tachometer screen ground. If required, change P215
F060	MLFB missing This is set, if the MLFB = 0 when INITIALIZATION is exited (0.0 kW). MLFB = Order No.	After acknowledgement, in INITIALIZATION enter the correct MLFB in parameter P070 MLFB (6SE70..) . (Only possible with the appropriate access stages to both access parameters).
F061	Incorr param. A parameter entered when setting the drive is not in the admissible range (e.g. P107 mot. frequency (ies), P108 mot. speed (s)), P761 pulse frequency) (dependent on the control type).	Acknowledge the fault, and change the appropriate parameter value. The erroneous parameter is specified in r949 as fault value.
F062	Multiparal. Fault was identified in conjunction with the multi-parallel circuit	<ul style="list-style-type: none"> • Check ImPI and the communications card and if required, replace • Check the configuration and connections of the multi-parallel circuit • Check parameterization (P070“MLFB(6SE70..)”) • Replace CU (-A10). • Replace ImPI
F065	INT1 telegram A telegram was not received at interface 1 (SST1/USS protocol) during the telegram failure time	<ul style="list-style-type: none"> • Check the connection PMU -X300. • Check P687.01“SST/SCB TLG-fail“. • Replace CU (-A10).
F066	INT2 telegram A telegram was not received at interface 2 (SST1/USS protocol) during the telegram failure time	<ul style="list-style-type: none"> • Check the connection CU -X100:1 to 5 • Check P687.03“SST/SCB TLG-fail“. • Replace CU (-A10).
F070	SCB init. Error when initializing the SCB board	r 949 =1 or 2 <ul style="list-style-type: none"> • Check the SCB board to ensure that it is correctly inserted and that the slot coincides with assignment • r723 board code , – r724 board ID and • P090 board slot 2 , – P091 board slot 3 r 949 =5 error, initialization data <ul style="list-style-type: none"> • Check parameters P682 and P684 r 949=6 time-out when initializing and r949=10 error, configuration channel <ul style="list-style-type: none"> • Check parameters P090, P091, P682 and P684
F072	SCB heartb. SCB no longer processes the monitoring counter (heartbeat counter)	Replace SCB Check the connection between the subrack and option board
F073	Aninput1 SL1 4 mA at analog input 1, slave 1 fallen below	Check the connection, signal source to the SCI 1 board (slave 1) -X428:4, 5.
F074	Aninput2 SL1 4 mA at analog input 2, slave 1 fallen below	Check the connection, signal source to the SCI 1 board (slave 2) -X428:7, 8.
F075	Aninput3 SL1 4 mA at analog input 3, slave 1 fallen below	Check the connection, signal source to the SCI 1 board (slave 3) -X428:10, 11.
F076	Aninput1 SL2 4 mA at analog input 1, slave 2 fallen below	Check the connection, signal source to the SCI1 (slave1) -X428:4, 5.
F077	Aninput2 SL2 4 mA at analog input 2, slave 2 fallen below	Check the connection, signal source to the SCI 1 board (slave 2) -X428:7,8.

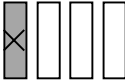
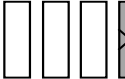
		Fault messages	
No.	Fault description	Counter measures	
F078	Aninput3 SL2 4 mA at analog input 3, slave 2 fallen below	Check the connection, signal source to the SCI 1 board (slave 3) -X428:10, 11.	
F079	SCB telegram A telegram was not received from the SCB (USS, peer-to-peer, SCI) during the telegram failure time.	<ul style="list-style-type: none"> • Check the connections of SCB1(2). • Check P687.01 "SST/SCB TLG-fail". • Replace SCB1(2). • Replace CU (-A10). 	
F080	TB/CB init. Error when initializing the board at the DPR interface	<p>r949 = 1 PT/CB not inserted or PT/CB board code incorrect r949 = 2 PT not compatible r949 = 3 CB not compatible r949 = 4 error, initialization data</p> <p>Check the T300/CB board to ensure that is correctly inserted and that the slot and assignment coincide;</p> <ul style="list-style-type: none"> • P090 board slot 2, • P091 board slot 3 • r723 board code, •r724 board ID <p>r949 = 5 time-out at initialization r949 = 10 error, configuration channel</p> <p>Checking the CB initialization parameters;</p> <ul style="list-style-type: none"> • P918 CB bus address, • 696 to P705 CB parameters 1 to 10 	
F081	TB/CB heartb TB or CB no longer processes the heartbeat counter	<p>Replace TB or CB</p> <p>Check the connection between the subrack and option boards</p>	
F082	TB/CB Tlgr. No new process data were received from TB or CB during the telegram failure. .	<ul style="list-style-type: none"> • Check the connections of the CB/TB. • Check P695 "CB/TB TLG-fail". • Replace CB. • Replace TB. 	
F090	Mess. param. An error occurred when attempting to change a parameter from the standstill measurement or the rotating measurement (mot. Id.).	Power-down and -up again. If it re-occurs, replace the CU board.	
F091	Mess. time The rotating measurement takes longer than programmed in a measuring status, possible causes: <ul style="list-style-type: none"> • load torque too high • load torque not uniform • Ramp-function generator inhibited 	Remove the cause and re-start the measurement (power-up the converter again). Replace the CU board if it re-occurs.	
F095	Mess.n(set) Due to entries for <ul style="list-style-type: none"> • Permissible phase sequence • Max. frequency, • Min. speed, • Changeover frequency between V- and I model, • Start of field weakening frequency, • Frequency suppression bandwidth, it was not possible to determine a permissible frequency range for the rotating measurement	<p>There must be a 10 % frequency range, which lies above 110 % of the changeover frequency and below 0.9 * of the frequency at the start of field weakening. Possible counter-measures;</p> <ul style="list-style-type: none"> • Permit both phase sequences • Increase the maximum frequency • Reduce the minimum speed, • Reduce the changeover frequency between V- and I model, • Reduce or remove the frequency suppression bandwidth. 	

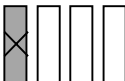
		Fault messages	
No.	Fault description		Counter measures
F096	Mess. abort The rotating measurement was aborted due to an inadmissible interruption from outside.		The fault value in r949 defines the intervention type: 4 Setpoint inhibit 5 Changeover, setpoint channel 8 Unexpected change in the converter status 12 Motor data set changeover (for function selection "complete mot ID") 13 Changeover to the slave drive 14 Motor data set changeover to data set with V/f_chara. 15 Controller inhibit is set 16 Ramp-function generator inhibited 17 "Tacho test" selected for closed-loop frequency control Remove fault
F097	Mess. meas. val. The measurements of the nominal ramp-up time when optimizing the controller deviate too greatly Cause: a very unsteady torque		If required increase the torque limit up to 100 %
F098	Mess. tachof The rotating measurement identified a speed actual value signal error. The fault value defines the error type. The error message can be erroneously generated, if the drive speed is externally forced (e.g. completely locked drive generates the "no signal" message).		The fault value in r949 defines the intervention type 4 No speed signal available 5 Incorrect signal polarity 6 One track signal missing 7 Incorrect gain 8 Incorrect pulse number Check the measuring cables. Instruction Manual 6SE7087-6CX84-3DA0 digital tachometer interface. Check the parameters. P208 S. speed act. val. P209 encoder pulse no.
F100	GRND init During the ground fault test, a current not equal to 0 was measured, or a UCE or the overcurrent monitoring responded, although none of the valves were triggered.		The fault cause can be read-out of r358 "ground fault test result". Check the converter output for short-circuit or ground fault (-X2:U2, V2, W2 - including motor). Check that the CU board is correctly inserted. Frame sizes 1 and 2: Check the transistor modules on the PEU board -A23 for short-circuit. Frame sizes 3 and 4: Check the transistor modules -A100, -A200, -A300 for a short-circuit condition.
F101	GRND UCE During the ground fault test a UCE monitoring function responded in a phase in which no valve was triggered		Check the power section valves for a short-circuit, and for converters with fiber-optic gating, the gating unit wiring and the UCE checkback signals, for the correct assignment. r358 can be interrogated to indicate which UCE monitoring has responded.
F102	GRND phase During the ground fault test, current flowed in one phase where none of the valves were triggered, or the UCE monitoring in the phase responded in which the valve was triggered.		Read-out the fault value from R949. The digit of the xth position indicates the valve, where the fault occurred at power-up.  Digit x = 1 = L2+ x = 2 = L2- x = 3 = L1+ x = 4 = L1- x = 5 = L3+ x = 6 = L3- The digit of the xth position defines the phase, in which I f is 0, and thus a valve is defective (always conductive)  Digit x = 1 = Phase 1 Digit x = 3 = Phase 3 Digit x = 4 = Phase 1 and 3 Check the phase assembly for defective valves (always conductive)

No.	Fault description	Fault messages
<p>F103</p>	<p>Ground fault An earth fault or a fault in the power section is present. During the ground fault test, a current flows from the phase in which a valve was triggered, the overcurrent comparator responded, or a UCE monitoring in a phase has responded in which a valve was triggered.</p>	<p>Read-out the fault value from r949. The digit of the xth position specifies the valve, which, when triggered, manifested the fault.</p>  <p> $x = 1 = V+$ $x = 2 = V-$ $x = 3 = U+$ $x = 4 = U-$ $x = 5 = W+$ $x = 6 = W-$ </p> <p>Check the motor including feeder cable for ground faults. If there is no ground fault, check the power section for defective valves which remain conductive.</p> <p>The digit of the xth position defines the phase in which I f is 0, and therefore a valve must be defective (always conductive).</p>  <p> 1 = Current in phase 1 (V) 2 = UCE in phase 2 (V) 3 = Current in phase 3 (V) 4 = Only overcurrent </p> <p>The motor speed should be less than 10 % of the rated speed during the ground fault test!</p> <p>1) A ground fault is present in phase V, or there is a defective valve (always conductive).</p>
<p>F107</p>	<p>Mld I = 0 During the test pulse measurement a fault occurred.</p>	<p>Read-out the fault value from r949. The digit of the xth position specifies the voltage direction at which the fault occurred.</p> <p> $xx = 01$: Both actual current valves remain 0 $xx = 02$: Connection between the motor-inverter, phase U is broken $xx = 03$: Connection between the motor-inverter, phase V is broken $xx = 04$: Connection between the motor-inverter, phase W is broken $xx = 05$: Actual current valve I1 remains 0 $xx = 06$: Actual current valve I3 remains 0 $xx = 07$: Valve U+ cannot be triggered $xx = 08$: Valve U- cannot be triggered $xx = 09$: Valve V+ cannot be triggered $xx = 10$: Valve V- cannot be triggered $xx = 11$: Valve W+ cannot be triggered $xx = 12$: Valve W- cannot be triggered $xx = 13$: Sign of I1 is wrong $xx = 14$: Sign of I3 is wrong $xx = 15$: Sign of I1 and I3 is wrong $xx = 16$: I1 and I3 swapped $xx = 17$: Sign of I1 and I3 wrong and I1 swapped with I3 </p>  <p>The digit of the xth position specifies the voltage direction at which the fault occurred.</p>  <p> $x = 0 =$ Single inverter $x = 1 =$ Inverter 1 $x = 2 =$ Inverter 2 $x = 3 =$ Inverter 1 and 2 </p> <p>Check that all three motor feeder cables and motor windings are not interrupted. Check the connections between the CT and electronics. Check that the correct rating plate data have been entered for the motor data set valid during the measurement.</p>

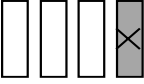
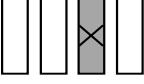
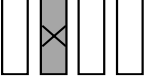
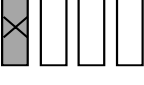
www.ElectricalPart.com

No.	Fault description	Fault messages	Counter measures
F108	Mess. unsym During the DC measurement, the measurement results for the individual phases differ significantly. The fault value indicates which quantity(s) is(are) involved, and in which phase the largest deviation occurred.	Read-out fault val. from r949. The dig.of xth pos. spec. the following:  Transverse voltage too high x = 1 = phase R x = 2 = phase S x = 3 = phase T  Dev., stator resistance (1, 2, 3 as above)  Dev., rotor resistance (1, 2, 3 as above)  Dev., dead time compensation (1, 2, 3 as above)  Deviation, valve voltage (1, 2, 3 as above) Motor, power section or actual value sensing are significantly non-symmetrical.	
F109	Mess. R(L) The rotor resistance, determined during the DC measurement, deviates too significantly from the value, which was calculated by the automatic parameterization from the rated slip.	<ul style="list-style-type: none"> Rated speed or rated frequency were incorrectly entered Incorrect pole pair number 	
F110	Mess. di/dt During the test pulse measurement, the current increased significantly faster than was expected. Thus, for the 1st test pulse, an overcurrent condition occurred within the first half of the minimum switch-on time.	<ul style="list-style-type: none"> There could be a short-circuit between two converter outputs The motor rating plate data were not correctly parameterized. The motor leakage is too low. 	
F111	Error e_fct. An error occurred while calculating the equalization function.		
F112	Unsym. I_sigma The individual leakage test results deviate too significantly.		
F114	Mess. OFF The converter automatically aborted the automatic measurement as the time limit was exceeded up to converter power-up, or due to an OFF command during the measurement; the selection in P052 function selection is reset.	For P052, function selection = 7 , restart motor identification at standstill . The on command must be provided within 20 s after the warning message A078 standstill measurement appears . Withdraw the off command and re-start the measurement.	
F115	KF internal	Power-down the converter and electronics and power-up again.	
F255	Fault in the NOVRAM	Power-down the converter and electronics and power-up again. If the fault occurs again, change the CU.	

Fatal errors (FF):

Fatal errors are those hardware or software errors which no longer permit normal converter operation. They only appear on the PMU in the form "FF<Nr>". The software is re-booted by actuating any PMU key.

FFxx	Error message	Power-down the converter and power-up again. Call the responsible service department if a fatal error message is re-displayed.
FF01	Time sector overflow A non-removable time sector overflow was identified in the higher priority time sectors.	<ul style="list-style-type: none"> • Increase the sampling time (P308) or reduce the pulse frequency (P761) • replace CU
FF03	Access error, option board A fatal error occurred when accessing the external option boards (CB, TB, SCB, TSY ..)	<ul style="list-style-type: none"> • replace CU • replace LBA • replace option board
FF06	Stack-Overflow Stack overflow.	<ul style="list-style-type: none"> • Increase the sampling time (P308) or reduce the pulse frequency (P761) • replace CU
FFxx	Other fatal errors.	<ul style="list-style-type: none"> • replace CU

12.2 Alarm messages

The alarm message is periodically displayed on the PMU by A=alarm and a 3-digit number. An alarm cannot be acknowledged. It is automatically deleted once the cause has been removed. Several alarms can be present. The alarms are then displayed one after another.

When the converter is operated with the OP1 operator control panel, the alarm is indicated in the lowest operating display line. The red LED additionally flashes (refer to the OP1 Instruction Manual).

Alarm No.	Parameter No. — Bit No.	Description	Counter-measures
A001	P953 — 0	Comp. time CU board comp. time utilization too high	observe r725 free computation time increase P308, sampling time or
A014	P953 — 13	Simulation The DC link voltage is not equal to zero when the simulation mode is selected (P733 = 1).	<ul style="list-style-type: none"> • set P733 to zero • drop the DC link voltage (remove the inverter from the mains)
A015	P953 — 14	Ext. alarm 1 External alarm input 1, which can be parameterized, was activated	External alarm! check whether the cable to the appropriate binary input is interrupted. Check parameter P588 S alarm ext. 1. ☞ Section "Binary inputs" in the Operating Instructions, Part 2
A016	P953 — 15	Ext. alarm 2 External alarm input 2, which can be parameterized, was activated	External alarm! check whether the cable to the appropriate binary input is interrupted. Check parameter P589 S alarm ext. 2. ☞ Section "Binary inputs" in the Operating Instructions, Part 2
A020	P954 — 3	Overcurrent An overcurrent condition has occurred.	Check the driven load for an overload condition. - are the motor and converter matched - are the dynamic performance requirements exceeded.
A021	P954 — 4	Overvoltage A DC link overvoltage condition has occurred.	Check the supply voltage. Converter regenerates without regeneration possibility.
A022	P954 — 5	Inv. temp. The threshold for initiating an alarm, which can be parameterized, was fallen below.	Observe r011 conv. temp. Measure the air intake or ambient temperature. Observe the de-rating curves for $\vartheta > 40\text{ °C}$ ☞ Section "Technical data" in the Operating Instructions, Part 1 Check: - whether fan -E1 is connected and is rotating in the correct direction. - the air intake and discharge openings for blockage. - the temperature sensor at -X30.
A023	P954 — 6	Mot temp The threshold to initialize an alarm, which can be parameterized, was exceeded.	Check the motor (load, ventilation etc.). Read-out the actual temperature in r009 mot.temp. Check the KTY84 input at connector -X104:25,26 for a short-circuit condition.
A025	P954 — 8	I2t- inv. If the instantaneous load condition is maintained, then the inverter will be thermally overloaded.	Check whether the rated output current or the peak current (operating class II) is (was) too high. View r010 conv. load
A029	P954 — 12	I2t motor The parameterized limit value for the motor I2t monitoring was exceeded.	Motor duty cycle is exceeded! Check parameters: P362 motor cooling P363 mot. temp. T1 P364 mot. load limits

Alarm No.	Parameter No. — Bit No.	Description	Counter-measures
A033	P955 — 0	Overspeed Bit in r553 status word 2 of the setpoint channel. The speed actual value has exceeded the maximum speed plus the selected hysteresis.	P519 overspeed hys. plus P452 max. frequency (RDF) / max. speed (RDF) or P453 max. frequency (LDF) / max.speed (LDF) has exceeded. Increase the parameter for the maximum frequencies, or reduce the regenerative load.
A034	P955 — 1	Setpoint- act. val. diff. Bit in the r552 status word 2 of the setpoint channel. The absolute difference between the frequency setpoint and actual value is greater than the parameterized value and the control monitoring time has expired.	Check; - whether an excessive torque requirement is available. - whether the motor was dimensioned too small. increase P517 setpoint-act. val. diff. frq./setp. act. diff. speed or P518 setp.-act. val. diff. time .
A035	P955 — 2	Wire breakage Clockwise and/or counter-clockwise rotating field is not enabled, or a wire is interrupted (both control word bits are zero)	Check, whether the cable(s) to the appropriate binary input(s), P572 S. clockwise phase sequence/P571 S. counter-clockwise phase sequence is (are) interrupted or withdrawn. ☞ Section "Binary inputs" in the Operating Instructions, Part 2
A041	P955 — 8	DC link overv. The supply voltage is too high or the converter supply voltage (P071) is incorrectly parameterized. The Vd_max. controller is inhibited, as otherwise the motor would immediately accelerate in operation up to the maximum frequency.	Check: - the supply voltage. - P071 conv. supply volt.
A042	P955 — 9	Mot. stall/lock Motor has stalled or is locked.	Reduce load. Check: - whether the drive is locked. - whether the drive has stalled.
A043	P955 — 10	n-act. jump The permissible rate of change of the speed encoder signal (P215) was exceeded.	Only for configured speed encoder P208 S. speed act. val. Check! Tacho cable for interruption. Tacho screen grounding.
A049	P956 — 0	No slave For serial I/O (SCB1 with SCI1/2), no slave is connected, opto-cable interrupted or slaves have no power.	P660 SCI AE config. • Check slave • Check cable
A050	P956 — 1	Slave incorrect For serial I/O, the slaves required according to the parameterized configuration are not present (slave number or slave type).	Check P660 SCI AE config.
A051	P956 — 2	Peer bdrate The peer-to-peer connection is too high or different baud rates have been selected.	Adapt the baud rate in conjunction with the SCB boards, P684 SST/SCB baud rate
A052	P956 — 3	Peer PZD-L for peer-to-peer connection, PZD length selected too high (>5).	Reduce the number of words P686 SST/SCB PZD No.
A053	P956 — 4	Peer lng f. For peer-to-peer connection, the PZD length of sender and receiver do not match.	Adapt the word length for sender and receiver P686 SST/SCB PZD No.

Alarm No.	Parameter No. — Bit No.	Description	Counter-measures				
A057	P956 — 8	TB-Param Technology Board Parameter occurs when a technology board is present, but parameterisation commands from the PMU, SST1 or SST2 are not answered by the technology board within 6 seconds	Change TB software				
A065	P957 — 0	WEA active The WEA option (P366) always restarts the drive. A possibly parameterized power-up delay time (P367) expires, if restart-on-the-fly is not selected. For DC link pre-charging, there is no time monitoring, i.e. with an external electronics power supply, it is also switched-in again.	 <table border="1" style="margin-left: 20px;"> <thead> <tr> <th colspan="2" style="text-align: center;">CAUTION</th> </tr> </thead> <tbody> <tr> <td colspan="2">Personnel could be endangered when the drive automatically restarts. Please check as to whether WEA (automatic restart) is really required. If required, change P366 WEA.</td> </tr> </tbody> </table>	CAUTION		Personnel could be endangered when the drive automatically restarts. Please check as to whether WEA (automatic restart) is really required. If required, change P366 WEA.	
CAUTION							
Personnel could be endangered when the drive automatically restarts. Please check as to whether WEA (automatic restart) is really required. If required, change P366 WEA.							
A066	P957 — 1	fsyn > fmax The measured target frequency of the external converter (or supply) is greater than the parameterized maximum frequency of the synchronizing converter.	Check that P452 max. freq. (RDF)/ P453 max. freq. (LDF) is correctly set, and the correct motor data set is selected P578 S.MDS bit 0 .				
A067	P957 — 2	fsyn < fmin The measured target frequency of the external converter (or supply) is less than the minimum frequency required for synchronizing.	Check: - r393 sync. tar. freq. - Synchronizing cable				
A068	P957 — 3	fsyn<>fset The setpoint frequency of the synchronizing converter is significantly different from the measured target frequency of the external converter (or supply). The permissible deviation can be set in P389 .	Adjust the complete setpoint (main- and supplementary setpoints) to the target frequency displayed in monitoring parameter r393 .				
A069	P957 — 4	RFG active Synchronizing is not started as long as the ramp-function generator in the synchronizing converter setpoint channel is active. This alarm is only output if synchronization has been selected.	Wait until acceleration has been completed. Check that P462 ramp-up time P463 units ramp-up time , have been correctly set.				
A070	P957 — 5	Sync. error This alarm is output, if the phase difference goes outside the synchronizing window (P 391) after synchronization.	The alarm can only be deleted after synchronization has been exited				
A071	P957 — 6	TSY missing An attempt was made to start synchronization with either the synchronizing board not inserted or not parameterized.	Insert the TSY board in the subrack, and parameterize P090 board slot 2 or P091 board slot 3 .				
A076	P957 — 11	t-comp lim. The determined compensation time was limited to 0.5µs - 1.5µs.	Converter and motor outputs are too different. Check motor data entries P100 to P109 .				
A077	P957 — 12	r-g limit The measured resistance is limited to the max. value of 49%.	Converter and motor outputs are too different. Check motor data entries P100 to P109 .				
A078	P957 — 13	Stands.meas The standstill measurement is executed when the converter is powered-up. With this measurement, the motor can align itself several times in any direction of rotation.	If the standstill measurement can be executed without any danger: Power-up the converter.				

Alarm No.	Parameter No. — Bit No.	Description	Counter-measures
A079	P957 — 14	Meas. inv. stop The rotating measurement was aborted, or cannot start because the inverter stop command is present.	Enable the converter P561 S. inv. enable , enable inverter or restart the measurement by powering-up the converter.
A080	P957 — 15	MotId:Dr.M. When the converter is powered-up, the rotating measurement automatically accelerates the drive. The drive can then only be externally controlled in a very restricted fashion.	If the standstill measurement can be executed without any danger: Power-up the converter.
A081.. A096	r958 — 0...15	CB alarm Refer to the User Manual, CB board	
A097.. A112	r959 — 0...15	TB alarm 1 Refer to the User Manual, TB board	
A113.. A128	r960 — 0...15	TB alarm 2 Refer to the User Manual, TB board	

www.ElectricalPartManuals.com

14 Index and Abbreviations

14.1 Index

Actual values.....	5-25	First start-up.....	4-2
Alarm messages	12-10	Flexible response.....	9-4
Analog input as setpoint input	6-3	Function selection (P052)	8-1
Analog input as speed actual value input.....	6-6	Functions (software)	9-1
Analog inputs	6-3	General explanation of the terminology and functional scope of the unit	3-1
Analog outputs	6-8	Initialization (P052 = 2)	8-2
Automatic parameterization (P052 = 6).....	8-7	Interfaces	6-1
Basic converter interfaces SST1 and SST2.....	6-10	KIP (Kinetic buffering).....	9-3
Binary inputs	6-1	Limit value stage in front of the ramp-function generator	6-15
Binary outputs	6-2	Logbook.....	13-1
Capacitor forming.....	4-1	Main-, output contactor	4-8
Complete motor identification (P052 = 8).....	8-11	Measures to maintain the radio interference suppression regulations.....	1-6
Connecting-up the control cables.....	1-2	motor identification at standstill (P052 = 7).....	8-9
Connecting-up the parameterizing unit (PMU)....	1-5	n/f-controller optimization (P052 = 10).....	8-14
Connectors for the control terminal strip	1-1	No-load measurement (P052 = 9)	8-13
Control terminal strip and serial interface.....	1-1	Open-loop and closed-loop control types	7-1
Control word (control word 1 and control word 2)5-1		Operator control.....	2-1
Control word 1 (Visualization parameter r550 or r967).....	5-2	Operator control elements	2-1
Control word 2 (Visualization parameter r551)....	5-3	Overview of the setpoints	5-23
DC current brake.....	9-9	Parameterization.....	4-3; 4-4
Displays.....	2-2	Process data.....	5-1
Download (P052 = 3)	8-5	Ramp-function generator (RFG) and limiting stage in front of the ramp-function generator	6-12
Dual port RAM (DPR for SCB, TSY, CB, TB) ...	6-11	Ramp-function generator, RFG	6-12
Factory setting (P052 = 1).....	8-1	Restart-on-the-fly	9-10
Fault and alarm messages.....	12-1		
Fault messages.....	12-1		

Selecting the possible setpoints sources.....	5-24	Status word	5-13
Selecting the source for control words 1 and 2 ...	5-4	Status word 1 (visualization parameter r552 or r968) ..	5-14
Self-test (P052 = 11)	8-15	Status word 2 (visualization parameter r553) ..	5-15
Serial interfaces.....	6-10	Structure	2-3
Setpoints	5-22	Tachometer test (P052 = 12)	8-16
Setting the short-time overload capability	9-8	Technology controller.....	9-13
Significance of control word- (1 and 2) commands.....	5-6	Temperature adaption	9-19
Significance of the status word messages	5-16	Terminal connection.....	1-3
Simple application examples for connecting process data with connection assignment	4-11	Tracer	9-17
Start-up	4-1	V/f characteristic	7-1
Start-up after enabling additional software functions or hardware options	4-10	Vdmax closed-loop control.....	9-7
Start-up functions	8-1	Vector control types	7-3
		WEA (automatic restart).....	9-1

www.ElectricalPartManuals.com

14.2 List of abbreviations

A	Alarm
AA	Analog output
AC	Alternating current
AE	Analog input
AFE	Active front end
AS	Sequence control
ASIC	Application specific integrated circuit
ASM	Asynchronous motor
ATI	Beliebig sinnvoll/sinnloser Kommentar
AWG	American wire gauge
BA	Binary output
BC	Bypass contactor
BE	Binary input
BF	Type of construction
CAN	Controller area network
CB	Communication board (option)
CU	Control unit
CUA	Control unit AFE (control unit of AFE)
DC	Direct current
DPR	Dual-port-RAM
DPRAM	Dual-port-RAM
EA	First run-up
EEPROM	Electrically erasable programmable read-only memory
EMC	Electromagnetic compatibility
EMF	Electromotive force
EPROM	Erasable programmable read-only memory
ESD	Electrostatic sensitive devices
F	Fault
FC	Frequency control (control version of SIMOVERT MASTER DRIVES)
FF	Fatal fault
FI	Fault current
FSW	Fixed setpoint
G/R	Basic/reserve
GSST(1/2)	Basic drive converter serial interface (1/2)
H	High (binary signal level)
HLG	Ramp-function generator
HTL	High-voltage transistor logic

HW	Hardware
I/O	Input/output
IGBT	Insulated gate bipolar transistor
IGD	IGBT gate drive
IVI	Inverter interface
KIP	Kinetic buffering
L	Low (binary signal level)
LBA	Local bus adapter (option)
LED	Light emitting diode
LSB	Least significant bit
MC	Main contactor
MDS	Motor data set
MLFB	Machine-readable product designation (machine-readable designation)
MSB	Most significant bit
NN	Sea level
OP(1)	Operation panel (1)
Par	Parameter
PC	Personal computer
PEU	Power electronic unit
PG	Programming unit (programmer)
PKW	Parameter ID value
PMU	Parameterization unit
PROFIBUS	Process field bus
PS	Power supply
PSU	Power supply unit
PWE	Parameter value
PZD	Process data
Q	Source
RC	Combination, resistor $\text{\textcircled{R}}$ and capacitor (C)
RDS	Reserve data set
RFG	Ramp-function generator
SC	Servo control (control version of SIMOVERT MASTER DRIVES)
SCB(1/2)	Serial communication board (option)
SCI(1/2)	Serial communication Interface (1/2)
SDS	Setpoint data set
SL	Slave
SM	Synchronous motor
SMD	Surface mounted device

SML	Snubber module low
SMU	Snubber module up
SST1/2	Serial interface 1/2
SW	Software
TB	Technology board (option)
TLG	Telegram
TRC	Trace
TSY	Tacho and synchronization (option)
TTL	Transistor-Transistor-Logic
UCE	Voltage (V) collector->emitter (desaturation signal of the transistors)
UMR	Drive converter
USS	Universal serial interface
VC	Vector control (control version of SIMOVERT MASTER DRIVES)
VDU	Voltage-dividing-unit
VS	Precharging contactor
Vsa	Line supply voltage components in the a axis
Vsb	Line supply voltage components in the b axis
VSB	voltage sensing board (line supply voltage sensing board)
WEA	Automatic restart function
WR	Inverter
X9	Terminal strip on the PEU (types A to D), PSU1 (types E to H) and PSU2 (types J to M)
ZK	DC link

www.ElectricalPartManuals.com

The following editions have been published so far:

Edition	Internal Item Number
AA	475 200.4000.76 J AA-76

Version AA consists of the following chapters:

Chapter	Changes	Pages	Version date
0 General	First edition	10	08.96
1 Control terminal strip and serial interface	First edition	6	08.96
2 Operator control	First edition	4	08.96
3 General explanation of the terminology and functional scope of the unit	First edition	2	08.96
4 Start-up	First edition	12	08.96
5 Process data	First edition	26	08.96
6 Interfaces	First edition	16	08.96
7 Open-loop and closed-loop control types	First edition	3	08.96
8 Start-up functions	First edition	16	08.96
9 Functions (software)	First edition	21	08.96
10 Function diagrams	First edition	19	08.96
11 Parameter list	First edition	92	08.96
12 Fault and alarm messages	First edition	14	08.96
13 Logbook	First edition	1	08.96
14 Index and abbreviations	First edition	5	08.96