



DESCRIPTION • RECEIVING • MAINTENANCE
INSTRUCTIONS

High Voltage
AIR BREAK
A-C MAGNETIC CONTACTORS

Class 15-823

Type	Poles	Volts	Amps.	Cycles
H-430A	3	5,000	200/400	25 to 60
H-430D	3	5,000	200/400	25 to 60
H-450D	5	5,000	200/400	25 to 60
H-403D	3	5,000	200/400	spring closed

WESTINGHOUSE ELECTRIC CORPORATION

MOTOR AND CONTROL DIVISION

BUFFALO PLANT
 NEW INFORMATION

BUFFALO 5, N. Y.
 JANUARY, 1955

Printed in U.S.A.

TABLE OF CONTENTS

Part One	DESCRIPTION	Pages 3-6
	Introduction	3
	General Description	4
	Operating Magnets	4
	Arc Chutes	4
	Arc Interruption	5
	Magnetic Latches	6
	Electrical Interlocks	6
	Mechanical Interlocks	6
Part Two	RECEIVING, HANDLING AND INSTALLING	Page 7
	Receiving	7
	Handling and Installing	7
Part Three	MAINTENANCE AND REPAIR	Pages 8-14
	General	8
	Contacts	8
	Shunts	9
	Replacing Coils—DC Magnets	9
	Replacing Coils—AC Magnets	10
	Reassembly—AC Magnets	10
	Electrical Interlock Adjustment	11
	Adjusting Magnetic Latches	12
	Arc Chutes	12
	Dismantling Arc Chutes	13
	Reassembling Arc Chutes	13
	Magnetic Coil Connections	14
	Engineering Data	14
	Renewal Parts List	14

LIST OF ILLUSTRATIONS

Figure		Page
1	Type H-430A—3 poles—A.C. Magnet	3
2	Type H-430D—3 poles—D.C. Magnet	3
3	Type H-450D—5 poles—D.C. Magnet	3
4	Type H-403D—3 poles—Spring closed	3
5	Details of A.C. Magnet	5
6	Arc Chute—Partial Assembly	6
7	D.C. Magnet Latch	7
8	D.C. Holding Magnet	8
9	Mechanical Interlock	9
10	Open for Inspection	9
11	Adjusting A.C. Magnet	10
12	L61 Electrical Interlock	11
13	Connections for A.C. Magnet Coils	11
14	Connections for D.C. Magnet Coils	12
15	Connections for 5 pole D.C. Magnet Coils	12
16	Connections for D.C. Magnet Coils—Synchronous Dynamic Braking Service	12

DESCRIPTION

INTRODUCTION

These instructions apply to Air Break Magnet Operated A-C Contactors of the following types:

Fig. 1—Type H-430A—3 poles—4800 volts—200/400 amps—25 to 60 cycles

Fig. 2—Type H-430D—3 poles—4800 volts—200/400 amps—25 to 60 cycles

Fig. 3—Type H-450D—5 poles—4800 volts—200/400 amps—25 to 60 cycles

Fig. 4—Type H-403D—3 poles—Spring Closed—4800 volts—400 amperes

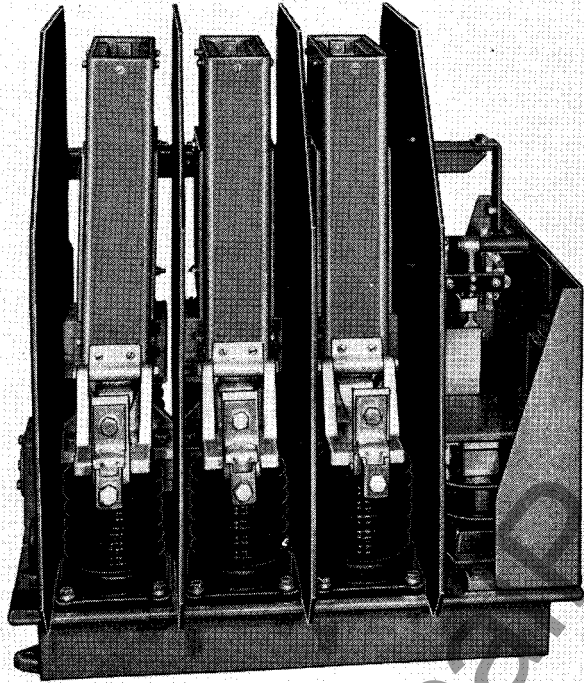

FIG. 1. Type H-430A—3 poles—A-C Magnet



FIG. 2. Type H-430D—3 poles—D-C Magnet

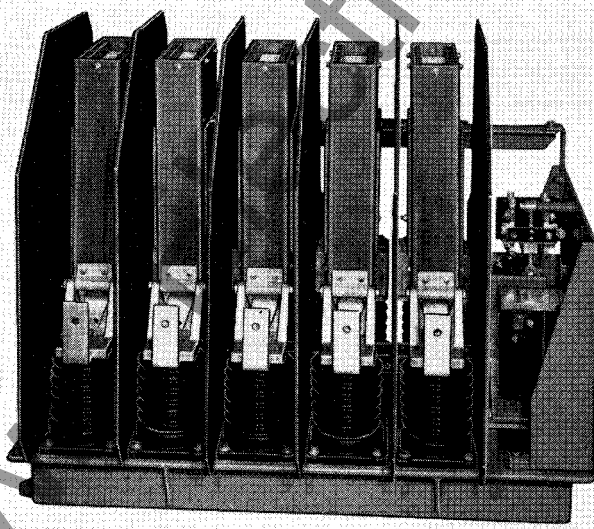

FIG. 3. Type H-450D—5 poles—D-C Magnet

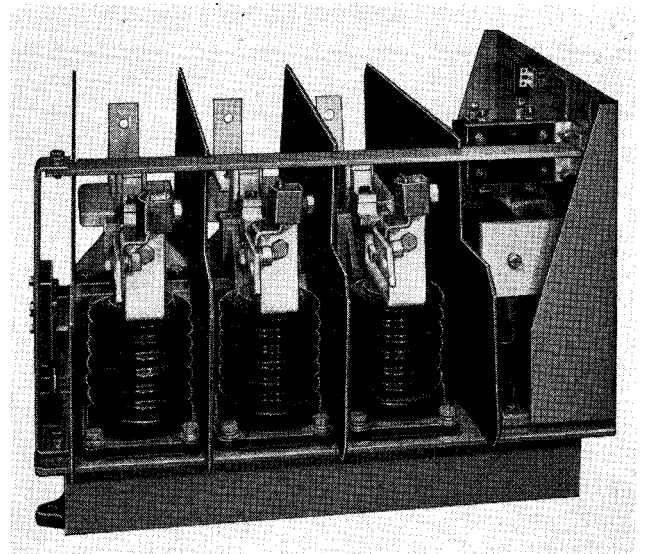

FIG. 4. Type H-403D—3 poles—Spring Closed

DESCRIPTION

GENERAL DESCRIPTION

These contactors are designed for equipment used in starting or controlling A-C motors on 2300, 4160, or 4800 volt power systems. They should not be used under any circumstances where the actual line voltage exceeds 5280 volts.

Continuous ratings of 200 and 400 amperes are available and are suitable for use with motors up to 3000 maximum horsepower. (See Table No. 2). When used as part of NEMA Class E1 totally enclosed and electrically coordinated controllers, the magnet closed contactors will interrupt short circuit current on circuits having available symmetrical KVA capacity as per Column 3 of Table I. When used as part of enclosed and coordinated NEMA Class E2 controllers, having fuses to interrupt the short circuit current, they may be used on circuits having available symmetrical KVA capacity as per Column 4 of Table No. 1.

Table No. 1

VOLTAGE RATING OF SYSTEM	8 HOUR CONTACTOR RATED AMPERES	SYMMETRICAL THREE PHASE AVAILABLE SHORT CIRCUIT CAPACITY IN KVA AT 25 to 60 CYCLES	
		Column 3	Column 4
Column 1	Column 2	Column 3	Column 4
2200-2500	200	25000	150,000
4000-4800	200	25000	250,000
2200-2500	400	50000	150,000
4000-4800	400	50000	250,000

The spring closed contactors are designed for dynamic braking of synchronous motors to close circuit only. They do not have any interrupting rating.

The magnet closed contactors may be used for D-C braking of high voltage A-C motors. For this application, their maximum D-C voltage rating is 250 volts and maximum D-C interrupting rating is 1000 amperes.

Before using on other than motor loads or where conditions are unusual or beyond the scope of above ratings, consult Westinghouse Electric Corporation giving complete rating of the motor, contactor, and other equipment.

OPERATING MAGNETS

The three pole type H-430A and H-430D magnet closed contactors are available with either A-C or D-C continuous rated magnet coils. The five pole type H-450D magnet closed and the type H-403D spring closed contactors are available with intermittent rated D-C magnet coils only. Voltage on these coils must be reduced after contactors have closed.

ARC CHUTES

Arc chutes are provided for each pole of magnet closed contactors. Easily removeable insulating barriers are used between poles and between poles and grounded parts. Since the arc chutes and barriers may be dismounted for shipment, make sure they are available and mounted in place. When mounting arc chutes, make certain that the blades on the outer arc runners enter the switch jaws attached to the contact parts. When fully engaged, the arc chutes will be vertical and the Micarta[®] jacket will rest against the blowout magnet laminations. **Never operate the contactors when line voltage is applied unless both the arc chutes and the barriers are in place. Failure to observe this precaution may result in injury or serious damage.**

Table No. 2
HORSEPOWER

TYPES	2200-2300 VOLTS			4000-4600 VOLTS		
	SYNCHRONOUS		INDUCTION	SYNCHRONOUS		INDUCTION
	100% Power Factor	80% Power Factor		100% Power Factor	80% Power Factor	
H-230A	900	700	700	1500	1250	1250
H-430A	1750	1500	1500	3000	2500	2500
H-230D	900	700	700	1500	1250	1250
H-250D	900	700	700	1500	1250	1250
H-430D	1750	1500	1500	3000	2500	2500
H-450D	1750	1500	1500	3000	2500	2500
H-403D	1750	1500		3000	2500	

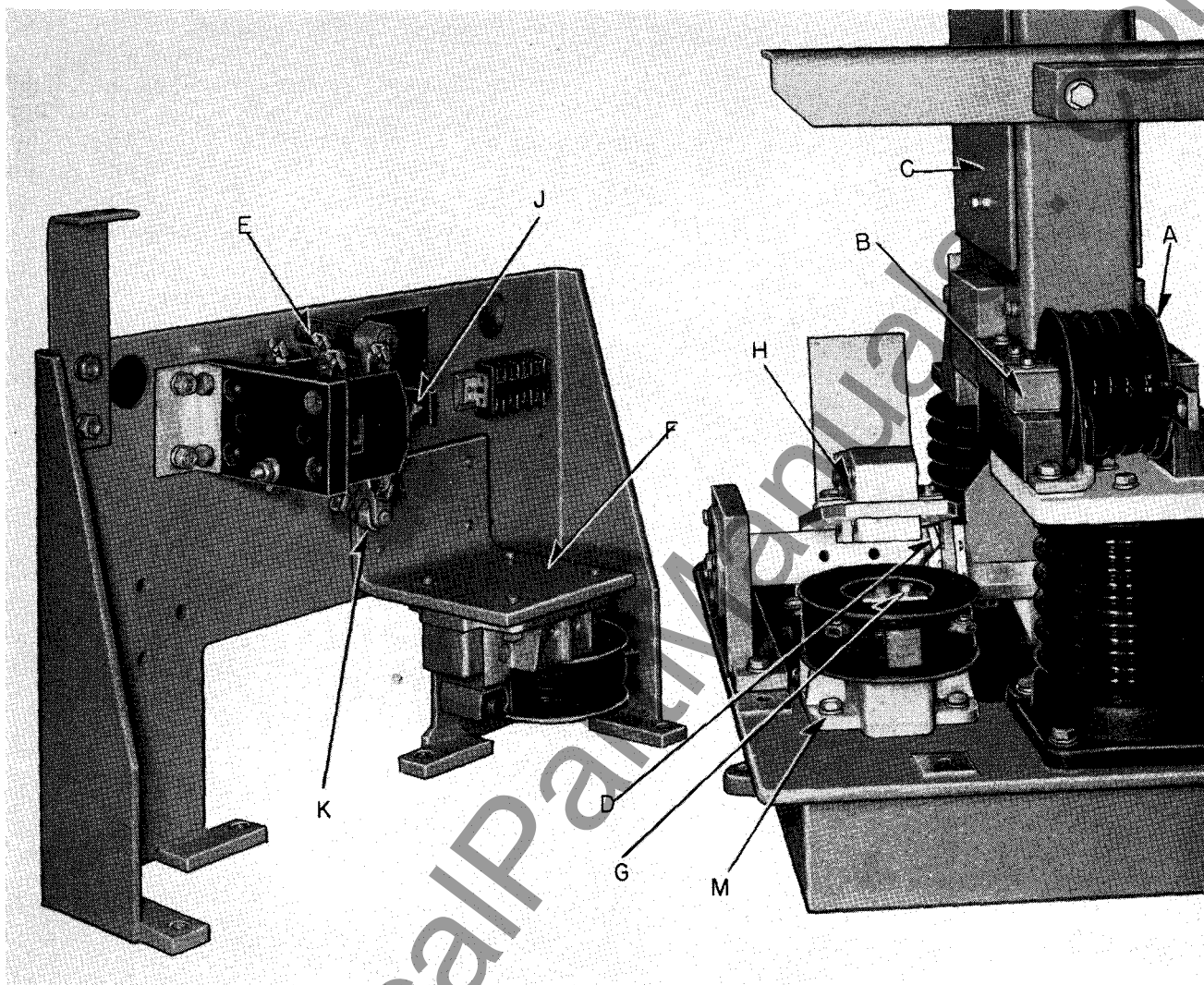

FIG. 5. Details of A-C Magnet

ARC INTERRUPTION

Provision has been made to rapidly extinguish the arcs resulting from circuit interruption and to confine the conducting arc gases within the arc chutes. Two separate systems of magnetic fields make this possible. A continuously rated blowout coil A, Fig. 5 is connected in series with each contact and a laminated steel yoke B, Fig. 5 is used to direct magnetic flux across the contacts. When an arc is drawn between contacts, this flux moves it upward into the arc chute.

Swinging the hinged arc chute into place automatically connects a pair of arc runners A, Fig. 6, to the contacts. These arc runners become electrical extensions of the contacts which serve to stretch out or lengthen the arc. In the process of traveling out along the runners the arc bows upward and strikes another pair of runners or plates B, Fig. 6, located near the center of the arc chute. This pair

of runners is connected together by another series blowout coil C, Fig. 6, having a much larger number of turns. This coil energizes a second laminated steel yoke C, Fig. 5, producing a much stronger magnetic flux and driving the arc rapidly into the arc stacks. These stacks are assemblies of zirconium refractory plates each having a gradually narrowing opening or slot. The plates are assembled with slots on alternate sides so that the arc, as it travels up into them, is caused to assume a zig-zag shape in which it is lengthened, restricted, and cooled until it becomes non-conducting.

The single arc started across the contact space is rapidly moved away from the contacts into the arc chute where it becomes two arcs in series connected together through a powerful blowout coil. Surrounding both sections of the arc there is an efficient zirconium base refractory quencher assembly. If an arc is established between the center

DESCRIPTION

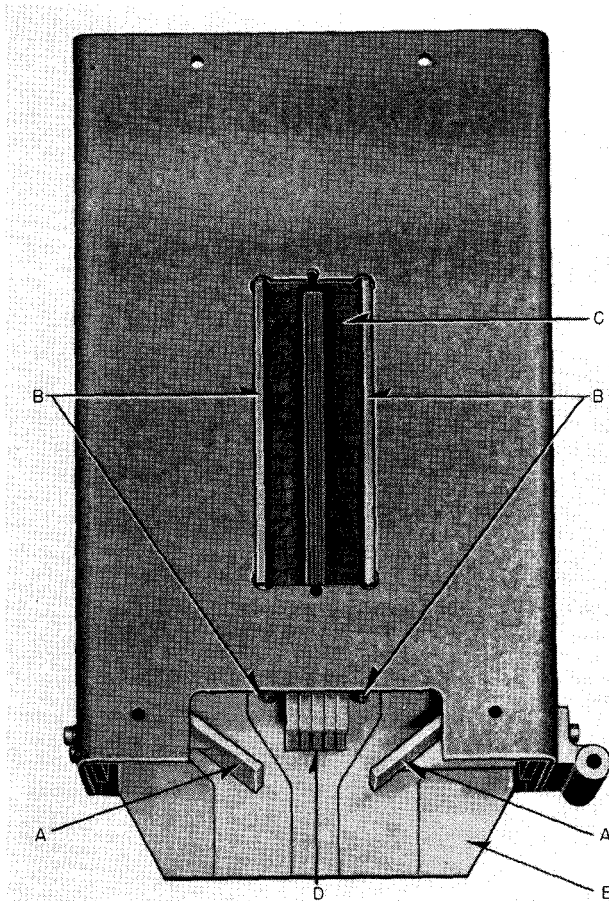

FIG. 6. Arc Chute—Partial Assembly

runners which are terminals of the second blowout coil, its voltage will be low and it will occur at the bottom end where there is a set of small auxiliary arc plates D, Fig. 6, designed to interrupt it.

MAGNETIC LATCHES

It is important to establish and maintain a suitable contact gap when the contactor is opening. In some contactors, spring forces and gravity are depended upon for this purpose. When opening heavy current, especially fault current, magnetic forces react in such a manner as to accelerate their opening speed. This speed may become large enough to cause bouncing and even reclosing of contacts unless preventive means are taken. Mechanical latches are provided on these contactors to engage and hold the magnet armatures in the open position. These latches are magnetically released when the magnets are energized to close the contactor, then drop back into position to reengage the armatures when their open position is reached. Rebounding is eliminated and there is no tendency for arcs to restrike across the contact gap.

The latch for the A-C magnet is shown at D in Fig. 5. It is supported on the stop bracket for the rear magnet where it interferes with closing movement unless it is magnetically retracted. Leakage flux from the magnet, when it is energized in the open position, retracts the latch. When the magnet has fully closed, the flux leakage disappears and the latch falls back against the magnet armature plate. It is then in position to drop under the plate and prevent rebounding. Should it be necessary to close the contactor by hand the latch must be pushed aside.

The latch for the D-C magnet is shown at A in Fig. 7. It is mounted beneath an extension of the lower armature plate. In principle, it operates just like the A-C magnet latch. The retracting magnet flux is furnished by a small electro magnet coil B, Fig. 7. The circuit to this coil includes a snap acting switch C, Fig. 7, which is closed only when the armature plate is resting against it. When the main magnet coils are energized, the latch magnet retracts the latch and permits the armature plates to move. This movement opens the switch, cuts off the latch coil current and puts the latch in position to drop under the armature plate and prevent rebounding.

ELECTRICAL INTERLOCKS

Each contactor is provided with auxiliary electrical interlock contacts E, Fig. 5, which will control four independent circuits. All of these may be normally open, or all normally closed, or any intermediate combination of normally open and normally closed. Selection of circuit arrangements is optional.

MECHANICAL INTERLOCKS

Mechanical interlocks, Fig. 9, are used to prevent two contactors from being closed simultaneously. These clamp around the operating shafts and project through openings in the end frames. Rods and fittings fastened to these projecting parts serve to transmit motion of one contactor to a corresponding point on the other where adjustments can be made. Adjust so that there will be no binding at either contactor and when one set of contact touches, the other set cannot be made to touch. When one set of contacts is fully closed, adjust for only enough movement of the other set to prevent binding of interlock parts.

When a spring closed contactor is interlocked with one or more magnet closed contactors, adjust the connecting rod lengths to exactly fit their lever arms when both sets of magnets are fully closed.

RECEIVING, HANDLING AND INSTALLING

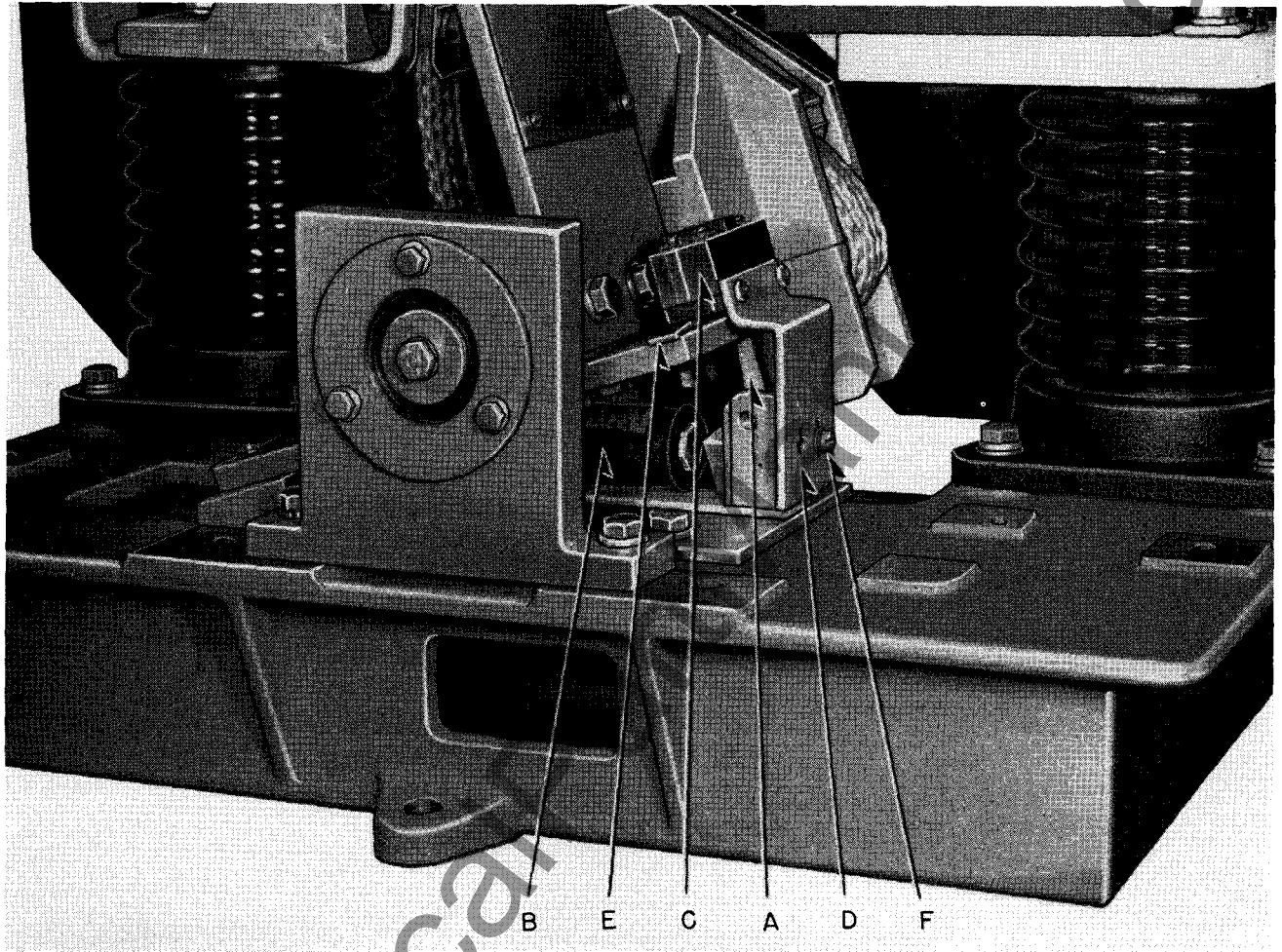

FIG. 7. D-C Magnet Latch

RECEIVING

These contactors are shipped completely assembled, except for the arc chutes and barriers which are packed separately. Immediately upon receipt, make a careful examination for any evidence of damage received in transit. Remove the shipping crate and packing material carefully using a nail puller instead of a hammer or wrecking bar. If any damage is found or suspected, file a claim promptly with the transportation company and notify the nearest Westinghouse Sales Office.

HANDLING & INSTALLING

Exercise care when handling and installing contactors. When lifting, use the lifting eyes provided and an equalizer bar or spreader for the cable sling. Install the arc chutes by rotating them carefully

into a vertical position. Make sure that the blades of the arc runners enter the contact jaws attached to stationary parts without fouling. Barriers should be installed between poles and between poles and grounded parts. Lift them far enough to clear the shaft, push them back against the barrier support, then move them down until they rest on the cast base between insulators.

When wiring cables to the blowout coils on the rear side of the contactor, use cable cleats provided. When wiring to the front side, locate cables so that arc boxes may be swung open to expose contact parts for inspection and replacement. Maximum accessibility will be obtained if the cables lead off horizontally to the left end or side away from the magnet. Brace these cables securely to prevent movement during the flow of heavy fault current.

PART THREE

MAINTENANCE AND REPAIR

GENERAL

Regular, systematic, and thorough inspection is recommended at least once a month, or oftener if

CONTACTS

Contacts are exposed and visible for inspection, Fig. 10, when the arc chutes are swung back on

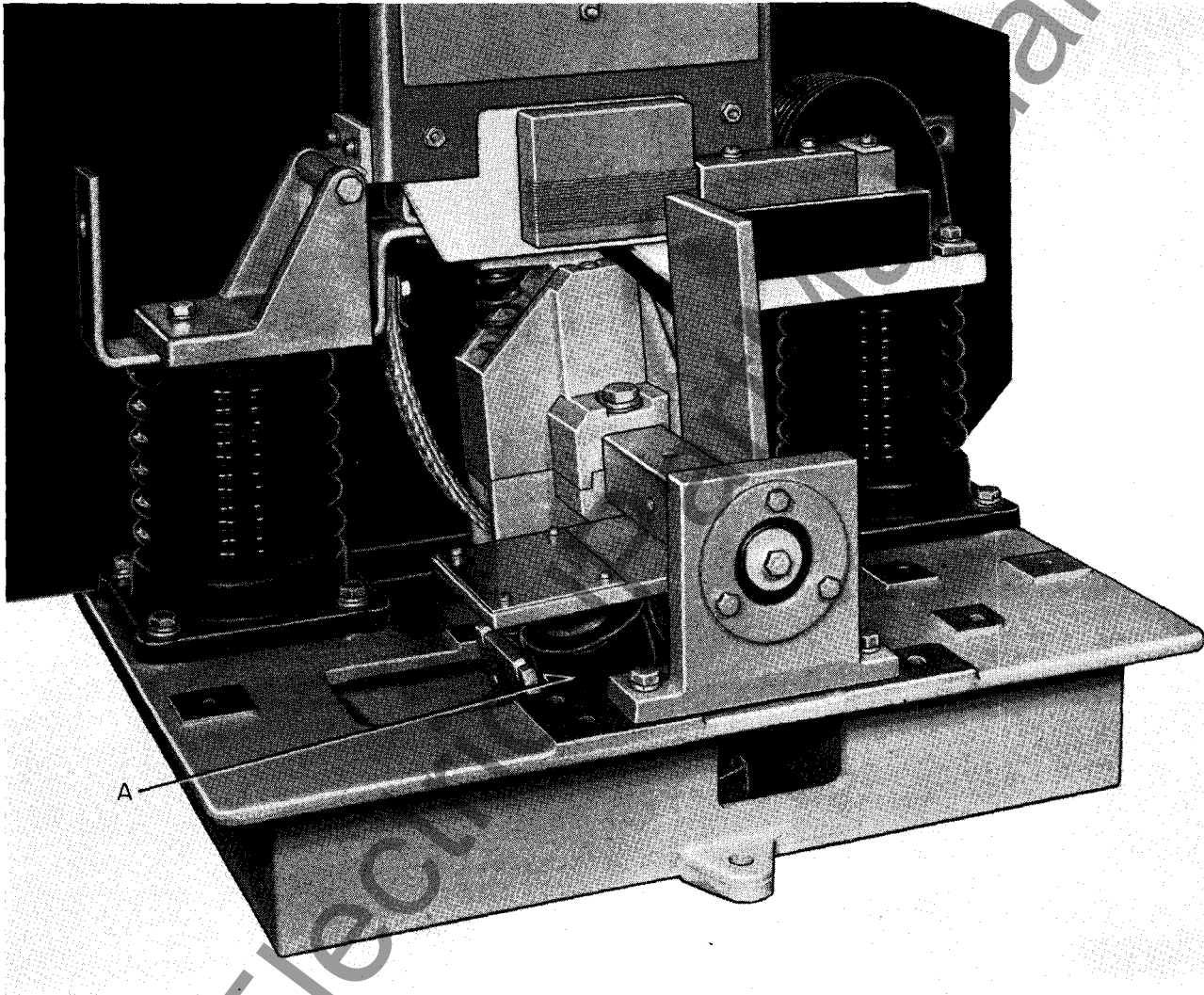

FIG. 8. D-C Holding Magnet

the contactor operates on a fast duty cycle. Be sure that the contactor and magnet are disconnected from all electric power before inspecting or repairing.

Keep the contactors clean, free from dust, water, oil or conducting material. Blowing off with compressed air at monthly inspection periods is recommended. If located where conducting dust is prevalent, more frequent cleaning is necessary.

their hinges. No special tools are needed to remove contact bolts. When replacing contacts, make sure that they fit down over the tenons on their supports and rest flat against support surfaces. Tighten bolts firmly until lock washers are fully compressed. All contacts should touch at nearly the same time. The allowable variation is $\frac{1}{32}$ ". Do not fail to swing arc chutes into place and re-install barriers.

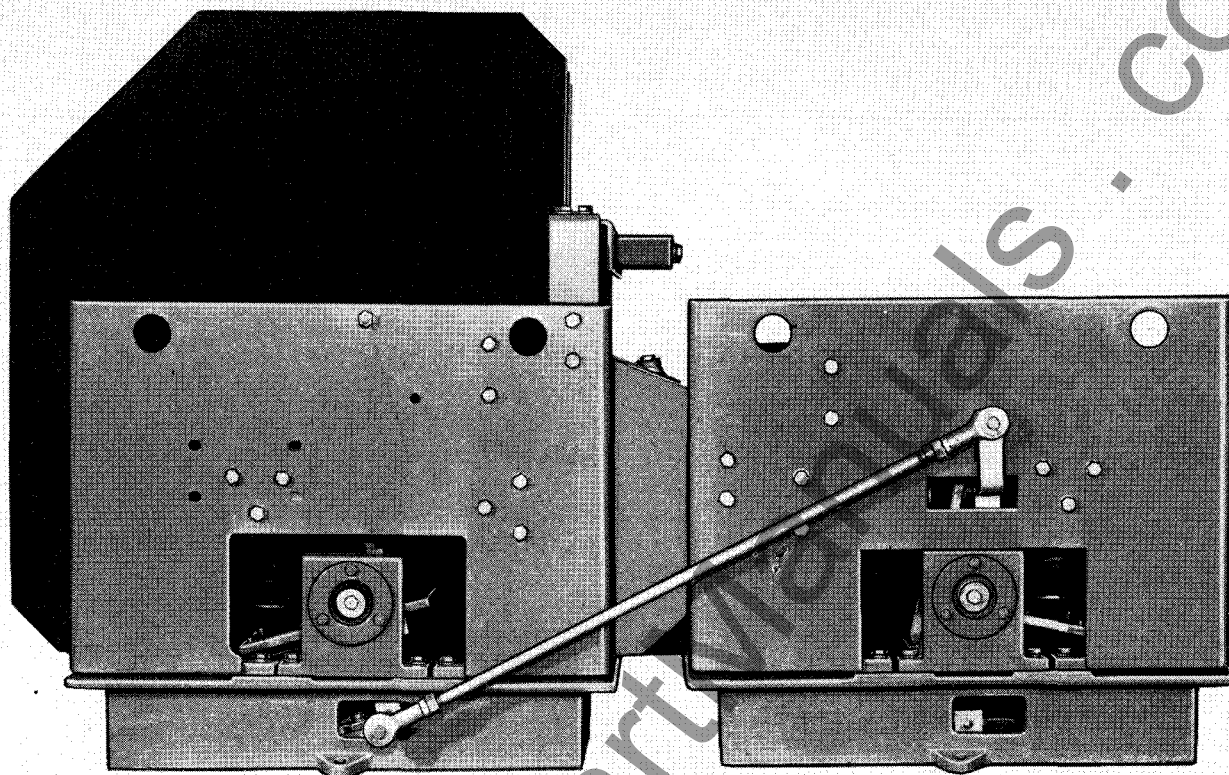

FIG. 9. Mechanical Interlock

SHUNTS

To replace shunts, Fig. 10, remove contacts, disconnect stationary ends of shunts by removing bolts A, remove contact hinge pin screws B, and withdraw the assembly of contact support and shunt. Shunt fastening bolts may then be removed.

REPLACING COILS—D-C MAGNETS

Disconnect leads from terminals and remove the bolts which hold the magnet cores to the right angle support brackets. Core and coil will then come off together. When replacing coils, the end which has a taped lead running across its face should be placed at the outer end of the core (end farthest from right angle support). The cushion washer should be placed at the other end, next to the support. Be careful not to pinch the washer between the core and support. Reconnect as before and check wiring to be sure of correct magnetic polarity which is not the same for both coils. Polarity will be right when the terminal nearest the end of one coil is connected to the same point as the opposite terminal on the other coil.

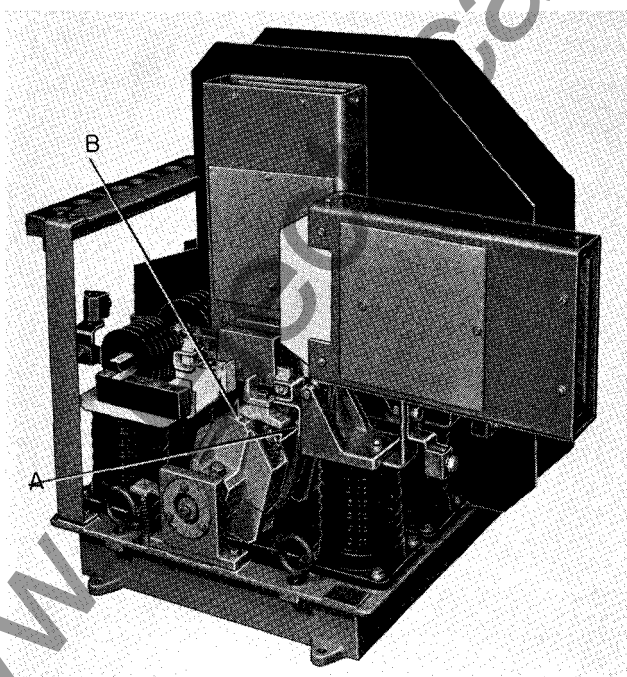

FIG. 10. Open for Inspection

MAINTENANCE AND REPAIR

Coils for D/C holding magnets A, Fig. 8, (when used) can best be removed by taking off the entire holding magnet. When replacing, assemble coil end with taped lead at the end of the core farthest from the angle frame. Polarity connections for this coil are not important.

REPLACING COILS—A-C MAGNETS

Disconnect leads from the terminals. For the front magnet F, Fig. 5, which is suspended from a bracket on the end frame, remove the stationary magnet and bracket together by taking out four bolts which secure the bracket to the end frame. The coil can then be replaced by removing the two bolts and a metal strip G, Fig. 5, fastening the coil to the magnet. When reassembling these bolts and strip, turn the strip so that its wider side is toward the outer edge of the coil.

For the rear magnet M, Fig. 5, which rests on the contactor base, it is necessary to remove the armature before the coil can be removed. This can be done by taking out two bolts tapped into the shaft. After this, the coil can be replaced as described above.

REASSEMBLY—A-C MAGNETS

When reassembling magnets, make sure that the laminated moving armatures close squarely over the laminated stationary parts with a minimum of overhang. No adjustment can be made on the rear magnet. Adjustment of the front magnet may be necessary to reduce magnet noise. Loosen the four bolts holding the bracket to the end frame, energize the coils and close the contactor. Place a lever preferably of the wood or insulating material, under the moving armature laminations, Fig. 11. Using the

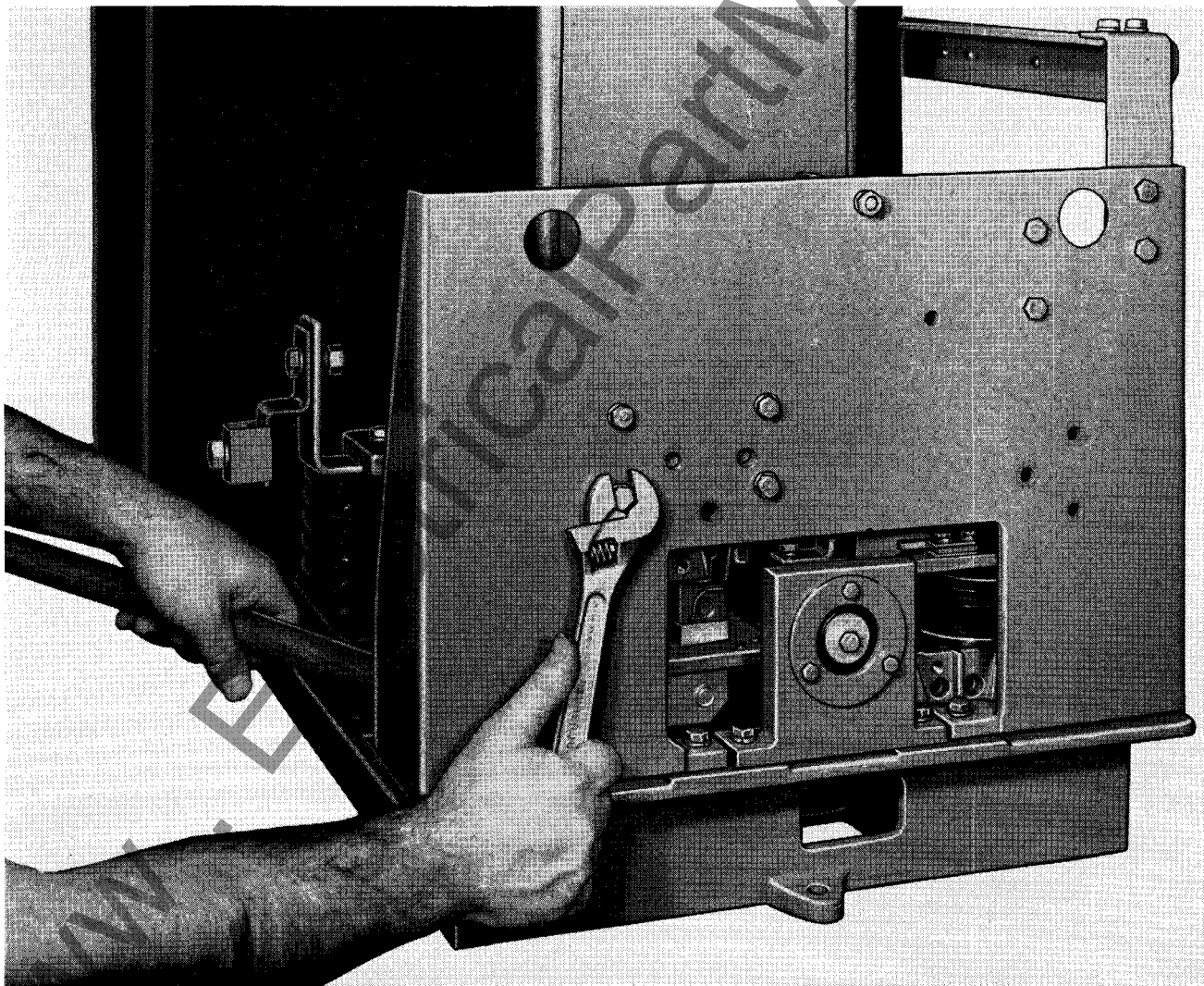

FIG. 11. Adjusting A-C Magnet

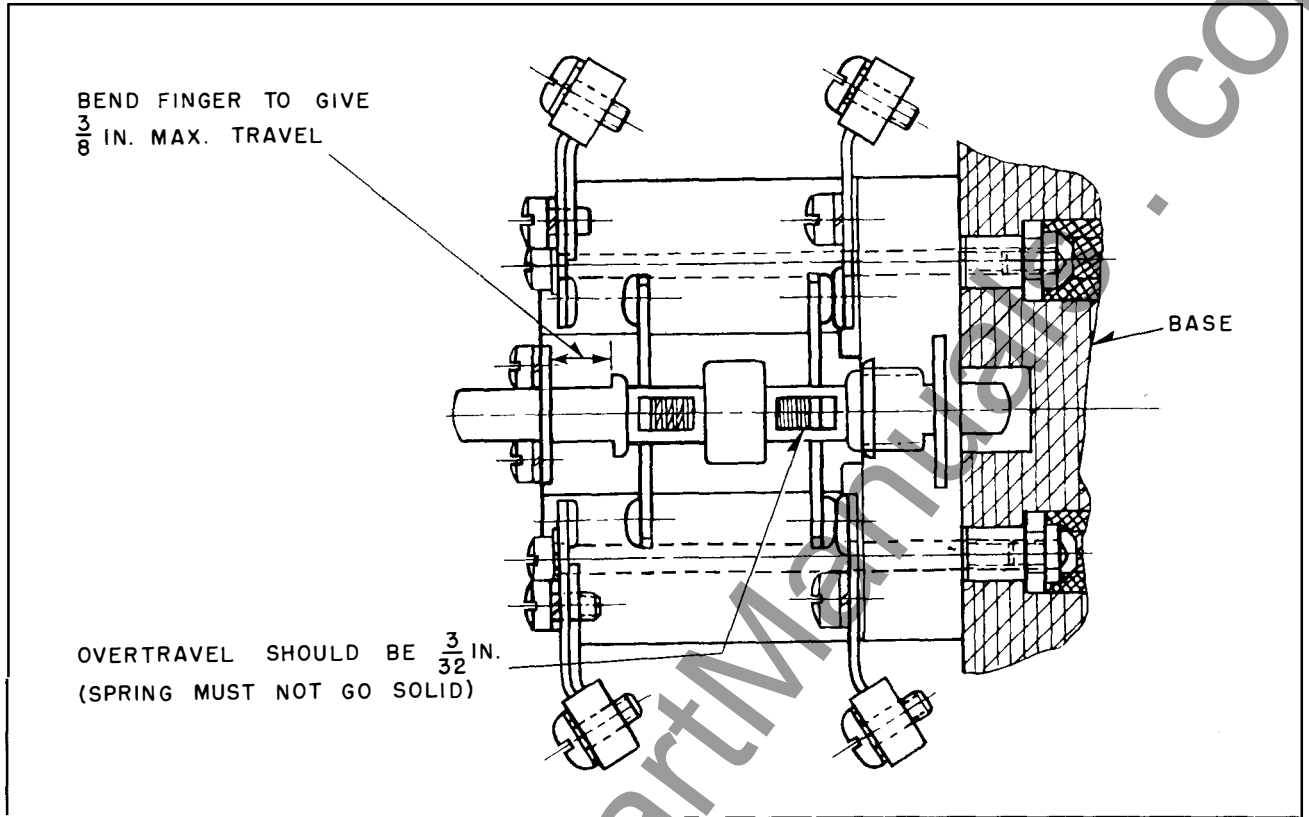

FIG. 12. L61 Electrical Interlock

edge of the cast base as a fulcrum, force the entire magnet upward until noise becomes minimum, then tighten the bracket to the end frame while maintaining pressure against the armature laminations. This should equalize the torque load on the two magnets. As a check, remove the lever and note

whether the space H, Fig. 5, between the moving laminations and the thick armature plate is approximately the same on both magnets. If it is not, the one having the larger space is carrying less than its share of the load. Readjustment may be necessary.

ELECTRICAL INTERLOCK ADJUSTMENT

The L-61 electrical interlocks are operated by movement of arms attached to the contactor shaft. Normal travel adjustment is done by means of adjusting screws J, Fig. 5. Fig. 12 shows where to measure travel and the amount of overtravel to be allowed. Contacts should be replaced when their overtravel is reduced to less than $\frac{1}{32}$ ".

Types H-430A and H-430D—3 pole and type H-450D—5 pole contactors have a hinged operating arm K, Fig. 5, in addition to the arm attached to the contactor shaft. Travel adjusting screws are attached to this arm. Overtravel is controlled by a hexagon headed bolt on the interlock base. Adjust its height until clearance between its head and the hinged operating arm does not exceed $\frac{1}{32}$ " when the contactor is fully closed. In this position, it should be possible to move the roller on the hinged arm approximately $\frac{1}{16}$ " away from the main operating arm.

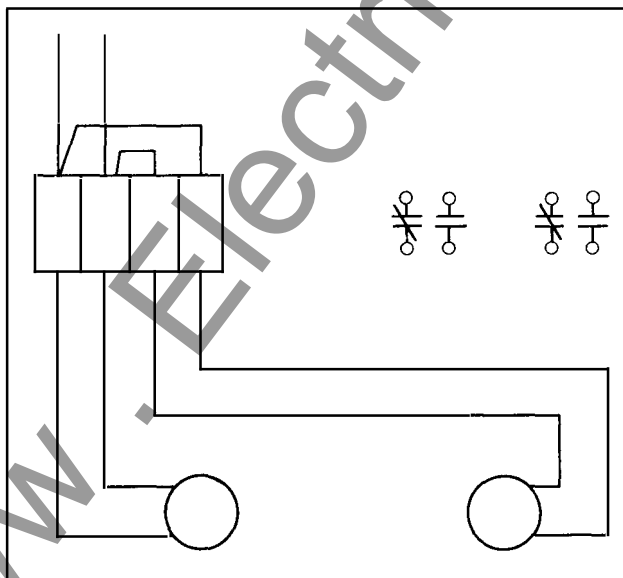

FIG. 13. Connections for A-C Magnet Coils

ADJUSTING MAGNETIC LATCHES

The magnetic latches, as previously explained, obstruct continued movement of the contactor armatures until the magnet coils are energized. There is a normal clearance of approximately $\frac{3}{64}$ " at the latch point which permits only enough armature movement to insure freedom of latch motion. Latches must move freely to get out of the way before the moving armature strikes them. Parts have been made light and non-corrodible.

Light springs of stainless steel wire normally bias the latches toward their normal latching position. Since the spring force is opposite to the magnetic force retracting the latch, it is important to maintain correct spring force. Care should be used to prevent distortion when removing or handling.

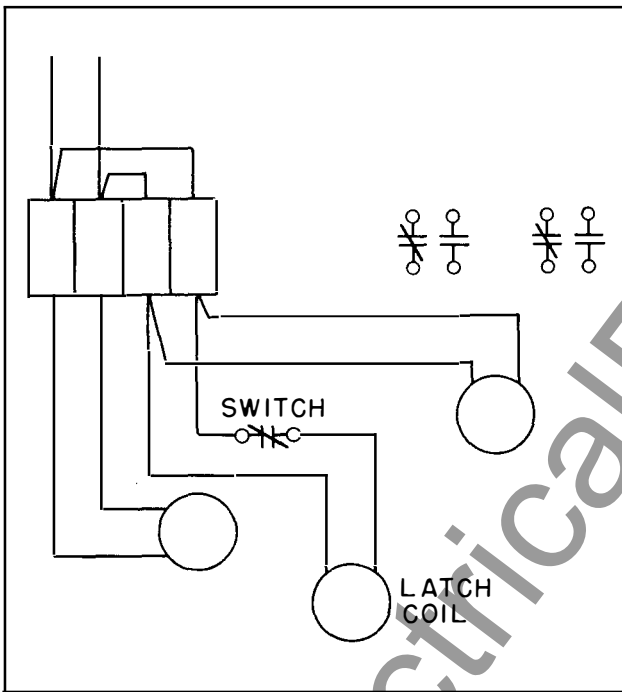

FIG. 14. Connections for 3 pole D-C Magnet Coils

The A-C magnet latch operates from the same magnetic flux that closes the contactor. A small adjusting screw controls the pickup of the latch. Factory adjustment of this screw should not be changed.

The D-C magnet latch operates from a separate small electro magnet. Its cutoff switch must be located accurately in order to close only when the armature is near its full open position. The small bracket on which the switch is mounted is provided with slotted holes D, Fig. 7 which allows a small up and down movement. To adjust switch position, place a $\frac{1}{32}$ " thick shim between the black switch

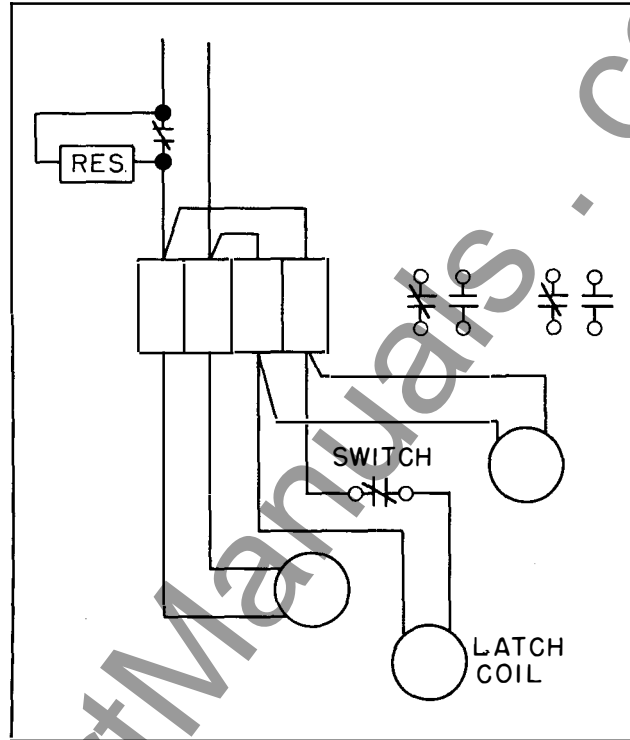

FIG. 15. Connections for 5 pole D-C Magnet Coils

operating button and the armature at point E, Fig. 7, then tighten screws F and remove the shim.

This switch has two circuits identified by diagrammatic symbols moulded in its case near the terminal screws. Use the circuit which is normally open and shown by symbol $\dashv \dashv$.

ARC CHUTES

Only the best and most suitable materials have been used in the efficiently designed arc chutes. Those in the direct path of the arc are non organic. Parts exposed to the high voltage arc are zirconium

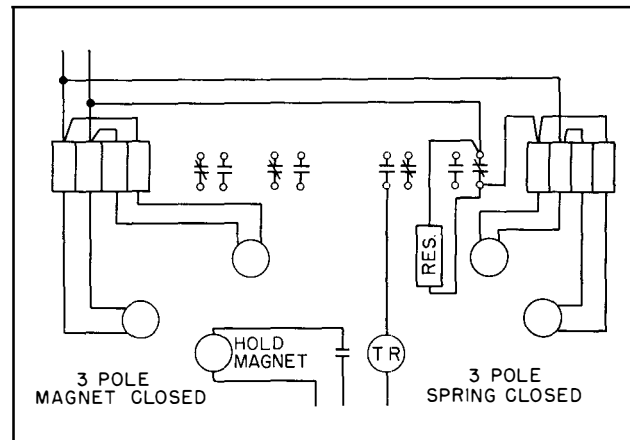

FIG. 16. Connections for D-C Magnet Coils— Synchronous Dynamic Braking Service

refractories proved by years of experience in Westinghouse contactors and air circuit breakers.

These materials are not burned by the intense heat of the arc but fuse and become glazed over on the surface. After prolonged use, or after interruption of heavy fault current, there may be enough erosion to require replacement. This should be noted especially at the narrow upper end of the slots in the arc stacks. When the upper end of the slot becomes enlarged beyond $\frac{3}{16}$ " diameter, the stack should be replaced.

The insulating parts of the arc chute remain in the circuit across the contacts at all times. During the time that the contacts are open, these insulating parts are subjected to the full voltage across the contactor. Ability to withstand this voltage depends upon the care given the insulation.

During general inspections, blow out the arc chute with dry compressed air directed upward from the contact area and out through each of the slots between the arc splitter plates. Direct the dry air thoroughly over the refractory liners in the lower end of the chute where the arc is drawn.

Periodically a more thorough inspection should be made by removing the arc stacks for cleaning and to permit examination of adjacent parts. Remove any residue of dirt or arc products with a cloth or by light sanding. Do not use a wire brush or emery cloth for this purpose as they may scratch or roughen the surfaces and invite increased future deposits of dirt.

The refractory material in the arc chutes may have a dirty appearance after repeated arc interruptions. This does not necessarily indicate low dielectric strength. If in doubt apply A-C test voltage not over 15 KV for 1 minute, or check insulation

resistance with a megger. Reading should be practically infinite.

DISMANTLING ARC CHUTES

To dismantle arc chutes for inspection, remove 4 fibre blocking strips at upper end, withdraw arc stacks and arc runner assemblies from top of chutes. Refractory liners at bottom end of arc chutes E, Fig. 6, and group of small arc splitter plates D, Fig. 6, near the contacts can be removed through the bottom of the chute. Should it be necessary to remove center arc runners, or blowout coils, remove entire laminated magnetic structure, disconnect the blowout coils at both top and bottom ends then pull the coils upward until clear. Center arc runner plates can then be removed one at a time if they are rotated about one edge until the opposite edge comes out of the rectangular hole in arc chute jacket.

REASSEMBLING ARC CHUTES

Reassemble center arc runners and blowout coils. Reinstall liners and arc splitter plates, assembling them so that slots in adjacent plates are staggered and do not line up with the slots in adjacent plates. Put outer arc runner assemblies in place noting that the narrower runner belongs on the hinge side of the chute. Next insert arc stacks with the side having a rope spacer turned toward the center arc runner. At the same time, make sure that the slot in the plate nearest the center of the chute is directly above the small arc tip brazed to the center runner. Use fish paper shims between the arc runner assemblies and the end walls of the micarta jacket to fill up surplus space. Install the small micarta tube above the blowout coils. Finally, replace fibre blocks to hold the entire assembly together.

MAINTENANCE AND REPAIR

MAGNET COIL CONNECTIONS

Figure 13 to Figure 16 illustrate schematically how the various magnet coils should be connected.

Engineering Data

DESCRIPTION	TYPE H-430A	TYPE H-430D	TYPE H-450D	TYPE H-403D
Number of Poles	3	3	5	3
Type of Operating Magnet ...	A-C	D-C	D-C	D-C
Outline Drawing	21C3423	21C3423	21C3424	32B1438
Weight—Pounds	500	500	750	350
Contact Gap—Inches	1¼	1¼	1¼	15/16
Contact Pressure—Pounds	30	30	30	10
Open Gap Volt Amperes	7200	285	460	350
Closed Gap Volt Amperes	640	175	175	175
Closed Gap Watts	160	175	175	175

RENEWAL PARTS LIST

DESCRIPTION	STYLE	QUANTITY PER CONTACTOR			
		Type H-430A	Type H-430D	Type H-450D	Type H-403D
Moving Contact	1780 613	3	3	5	3
Stationary Contact	1780 614	3	3	5	3
Shunt	1780 669	3	3	5	3
Contact Spring	1780 601	3	3	5	..
Arc Chute Complete	1780 702	3	3	5	..
Arc Stacks	1799 417	6	6	10	..
Auxiliary Arc Plates	1799 936	15	15	25	..
Electrical Interlock Complete	1486 685	2	2	2	2
Front Stationary Contact	1625 818	4	4	4	4
Rear Stationary Contact	1745 080	4	4	4	4
Moving Contact	1437 667	4	4	4	4
Contact Spring	1486 698	4	4	4	4
Push Rod Spring	1486 697	2	2	2	2
Contact Spring	1780 619	3
* Coils					

* Order coils by style number appearing on coil label.

www.ElectricalArtManuals.com





DESCRIPTION • RECEIVING • MAINTENANCE

INSTRUCTIONS

High Voltage

AIR BREAK

A-C MAGNETIC CONTACTORS

Class 15-823

Type	Poles	Volts	Amps.	Cycles
H-430A	3	5,000	200/400	25 to 60
H-430D	3	5,000	200/400	25 to 60
H-450D	5	5,000	200/400	25 to 60
H-403D	3	5,000	200/400	spring closed

WESTINGHOUSE ELECTRIC CORPORATION

MOTOR AND CONTROL DIVISION

BUFFALO PLANT

SUPERSEDES I.B. 15-823-1

BUFFALO 5, N. Y.

JANUARY, 1957

Printed in U.S.A.

TABLE OF CONTENTS

Part One	DESCRIPTION	Pages 3-6
	Introduction	3
	General Description	4
	Operating Magnets	4
	Arc Chutes	4
	Arc Interruption	5
	Magnetic Latches	6
	Electrical Interlocks	6
	Mechanical Interlocks	6
Part Two	RECEIVING, HANDLING AND INSTALLING	Page 7
	Receiving	7
	Handling and Installing	7
Part Three	MAINTENANCE AND REPAIR	Pages 8-14
	General	8
	Contacts	8
	Shunts	9
	Replacing Coils—DC Magnets	9
	Replacing Coils—AC Magnets	10
	Reassembly—AC Magnets	10
	Electrical Interlock Adjustment	11
	Adjusting Magnetic Latches	12
	Arc Chutes	12
	Dismantling Arc Chutes	13
	Reassembling Arc Chutes	13
	Magnetic Coil Connections	14
	Engineering Data	14
	Renewal Parts List	14

LIST OF ILLUSTRATIONS

Figure		Page
1	Type H-430A—3 poles—A.C. Magnet	3
2	Type H-430D—3 poles—D.C. Magnet	3
3	Type H-450D—5 poles—D.C. Magnet	3
4	Type H-403D—3 poles—Spring closed	3
5	Details of A.C. Magnet	5
6	Arc Chute—Partial Assembly	6
7	D.C. Magnet Latch	7
8	D.C. Holding Magnet	8
9	Mechanical Interlock	9
10	Open for Inspection	9
11	Adjusting A.C. Magnet	10
12	L61 Electrical Interlock	11
13	Connections for A.C. Magnet Coils	11
14	Connections for D.C. Magnet Coils	12
15	Connections for 5 pole D.C. Magnet Coils	12
16	Connections for D.C. Magnet Coils—Synchronous Dynamic Braking Service	12

DESCRIPTION

INTRODUCTION

These instructions apply to Air Break Magnet Operated A-C Contactors of the following types:

Fig. 1—Type H-430A—3 poles—4800 volts—200/400 amps—25 to 60 cycles

Fig. 2—Type H-430D—3 poles—4800 volts—200/400 amps—25 to 60 cycles

Fig. 3—Type H-450D—5 poles—4800 volts—200/400 amps—25 to 60 cycles

Fig. 4—Type H-403D—3 poles—Spring Closed—4800 volts—400 amperes

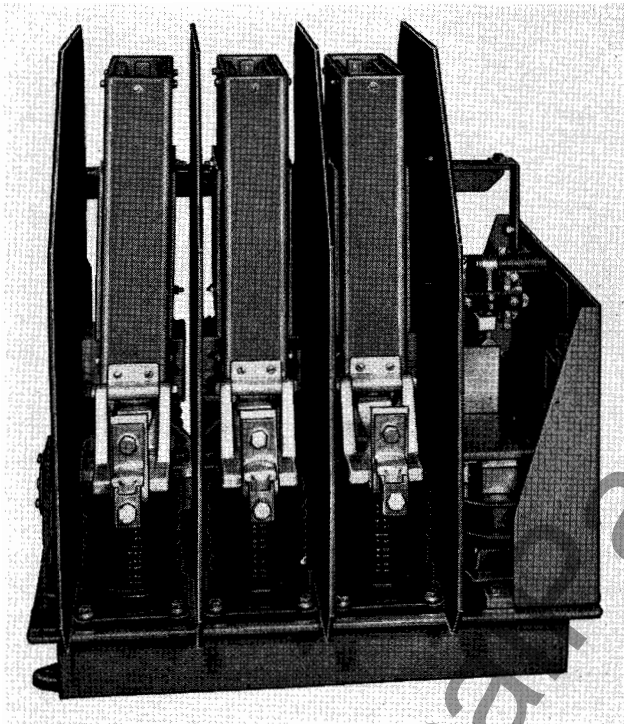

FIG. 1. Type H-430A—3 poles—A-C Magnet

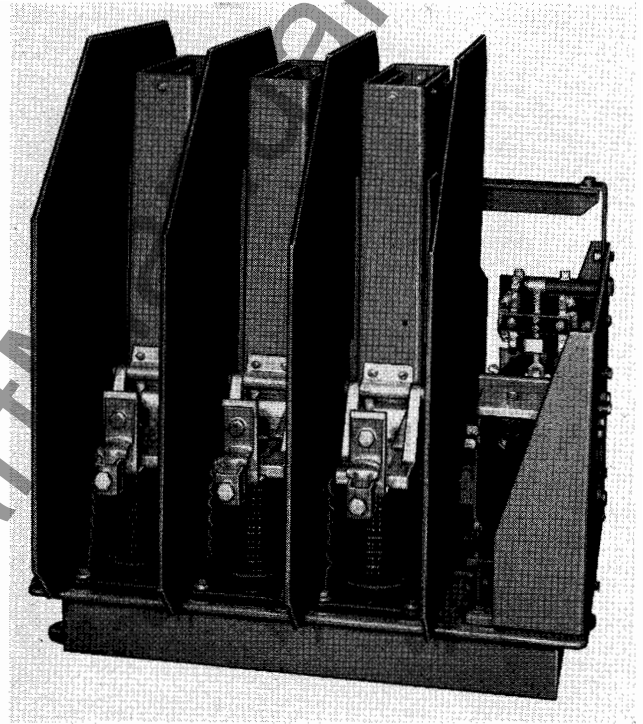

FIG. 2. Type H-430D—3 poles—D-C Magnet

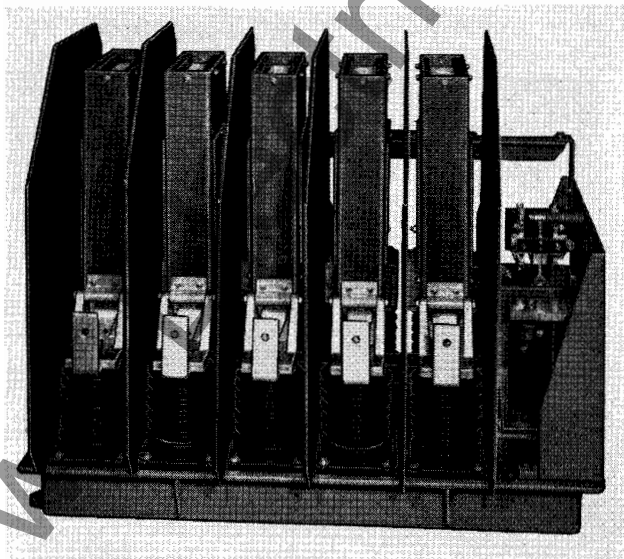

FIG. 3. Type H-450D—5 poles—D-C Magnet

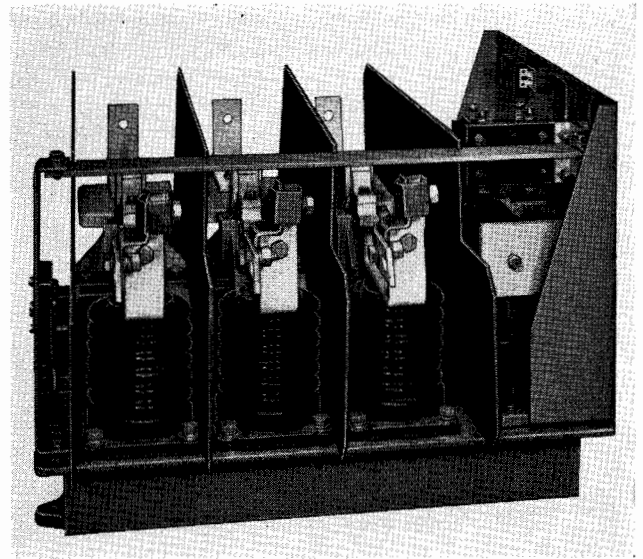

FIG. 4. Type H-403D—3 poles—Spring Closed

DESCRIPTION

GENERAL DESCRIPTION

These contactors are designed for equipment used in starting or controlling A-C motors on 2300, 4160, or 4800 volt power systems. They should not be used under any circumstances where the actual line voltage exceeds 5280 volts.

Continuous ratings of 200 and 400 amperes are available and are suitable for use with motors up to 3000 maximum horsepower. (See Table No. 2). When used as part of NEMA Class E1 totally enclosed and electrically coordinated controllers, the magnet closed contactors will interrupt short circuit current on circuits having available symmetrical KVA capacity as per Column 3 of Table I. When used as part of enclosed and coordinated NEMA Class E2 controllers, having fuses to interrupt the short circuit current, they may be used on circuits having available symmetrical KVA capacity as per Column 4 of Table No. 1.

Table No. 1

VOLTAGE RATING OF SYSTEM	8 HOUR CONTACTOR RATED AMPERES	SYMMETRICAL THREE PHASE AVAILABLE SHORT CIRCUIT CAPACITY IN KVA AT 25 to 60 CYCLES	
		Column 3	Column 4
Column 1	Column 2	Column 3	Column 4
2200-2500	200	25000	150,000
4000-4800	200	25000	250,000
2200-2500	400	50000	150,000
4000-4800	400	50000	250,000

The spring closed contactors are designed for dynamic braking of synchronous motors to close circuit only. They do not have any interrupting rating.

The magnet closed contactors may be used for D-C braking of high voltage A-C motors. For this application, their maximum D-C voltage rating is 250 volts and maximum D-C interrupting rating is 1000 amperes.

Before using on other than motor loads or where conditions are unusual or beyond the scope of above ratings, consult Westinghouse Electric Corporation giving complete rating of the motor, contactor, and other equipment.

OPERATING MAGNETS

The three pole type H-430A and H-430D magnet closed contactors are available with either A-C or D-C continuous rated magnet coils. The five pole type H-450D magnet closed and the type H-403D spring closed contactors are available with intermittent rated D-C magnet coils only. Voltage on these coils must be reduced after contactors have closed.

ARC CHUTES

Arc chutes are provided for each pole of magnet closed contactors. Easily removeable insulating barriers are used between poles and between poles and grounded parts. Since the arc chutes and barriers may be dismantled for shipment, make sure they are available and mounted in place. When mounting arc chutes, make certain that the blades on the outer arc runners enter the switch jaws attached to the contact parts. When fully engaged, the arc chutes will be vertical and the Micarta^(R) jacket will rest against the blowout magnet laminations. **Never operate the contactors when line voltage is applied unless both the arc chutes and the barriers are in place. Failure to observe this precaution may result in injury or serious damage.**

Table No. 2
HORSEPOWER

TYPES	2200-2300 VOLTS			4000-4600 VOLTS		
	SYNCHRONOUS		INDUCTION	SYNCHRONOUS		INDUCTION
	100% Power Factor	80% Power Factor		100% Power Factor	80% Power Factor	
H-230A	900	700	700	1500	1250	1250
H-430A	1750	1500	1500	3000	2500	2500
H-230D	900	700	700	1500	1250	1250
H-250D	900	700	700	1500	1250	1250
H-430D	1750	1500	1500	3000	2500	2500
H-450D	1750	1500	1500	3000	2500	2500
H-403D	1750	1500	1500	3000	2500	2500

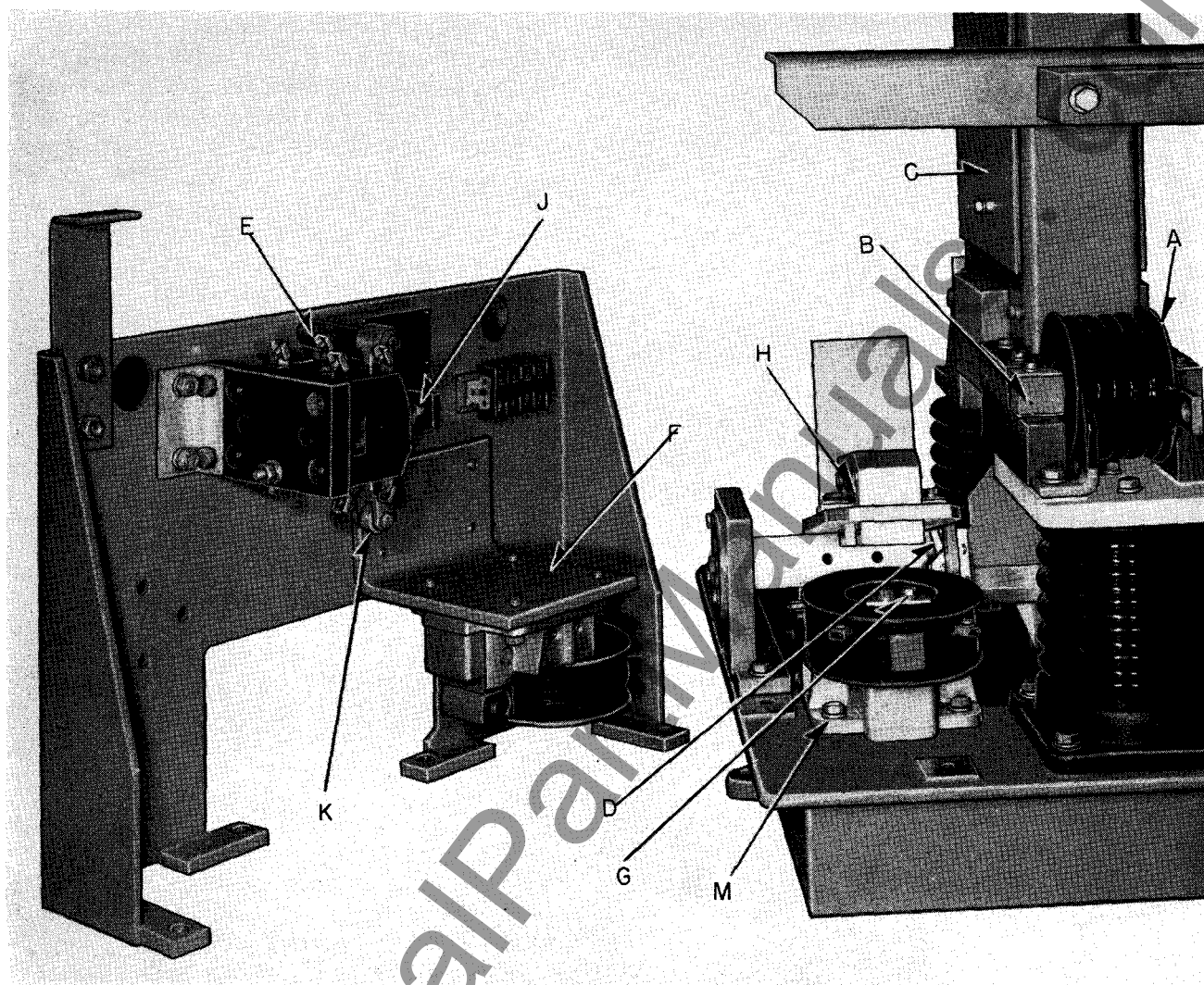

FIG. 5. Details of A-C Magnet

ARC INTERRUPTION

Provision has been made to rapidly extinguish the arcs resulting from circuit interruption and to confine the conducting arc gases within the arc chutes. Two separate systems of magnetic fields make this possible. A continuously rated blowout coil A, Fig. 5 is connected in series with each contact and a laminated steel yoke B, Fig. 5 is used to direct magnetic flux across the contacts. When an arc is drawn between contacts, this flux moves it upward into the arc chute.

Swinging the hinged arc chute into place automatically connects a pair of arc runners A, Fig. 6, to the contacts. These arc runners become electrical extensions of the contacts which serve to stretch out or lengthen the arc. In the process of traveling out along the runners the arc bows upward and strikes another pair of runners or plates B, Fig. 6, located near the center of the arc chute. This pair

of runners is connected together by another series blowout coil C, Fig. 6, having a much larger number of turns. This coil energizes a second laminated steel yoke C, Fig. 5, producing a much stronger magnetic flux and driving the arc rapidly into the arc stacks. These stacks are assemblies of zirconium refractory plates each having a gradually narrowing opening or slot. The plates are assembled with slots on alternate sides so that the arc, as it travels up into them, is caused to assume a zig-zag shape in which it is lengthened, restricted, and cooled until it becomes non-conducting.

The single arc started across the contact space is rapidly moved away from the contacts into the arc chute where it becomes two arcs in series connected together through a powerful blowout coil. Surrounding both sections of the arc there is an efficient zirconium base refractory quencher assembly. If an arc is established between the center

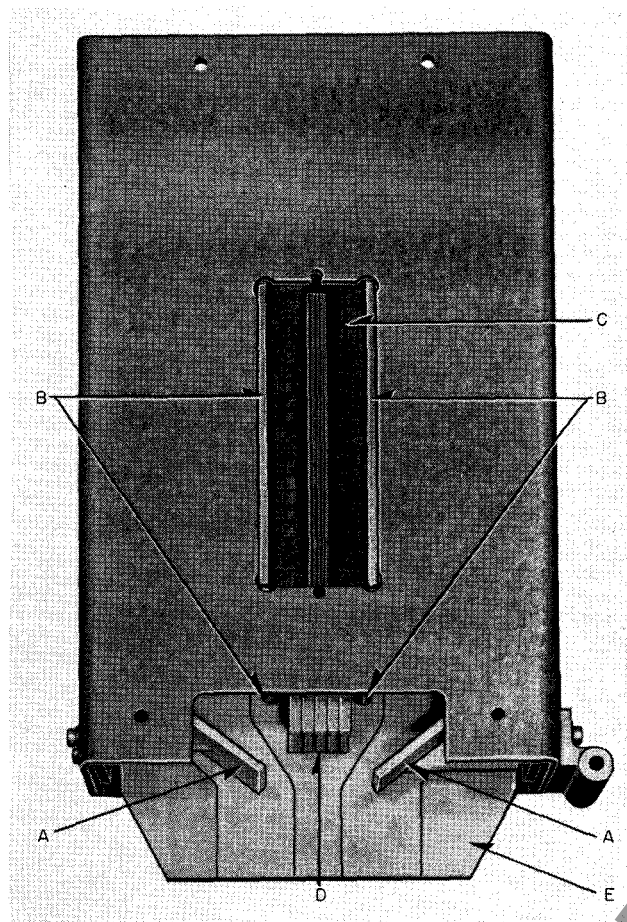

FIG. 6. Arc Chute—Partial Assembly

runners which are terminals of the second blowout coil, its voltage will be low and it will occur at the bottom end where there is a set of small auxiliary arc plates D, Fig. 6, designed to interrupt it.

MAGNETIC LATCHES

It is important to establish and maintain a suitable contact gap when the contactor is opening. In some contactors, spring forces and gravity are depended upon for this purpose. When opening heavy current, especially fault current, magnetic forces react in such a manner as to accelerate their opening speed. This speed may become large enough to cause bouncing and even reclosing of contacts unless preventive means are taken. Mechanical latches are provided on these contactors to engage and hold the magnet armatures in the open position. These latches are magnetically released when the magnets are energized to close the contactor, then drop back into position to reengage the armatures when their open position is reached. Rebounding is eliminated and there is no tendency for arcs to restrike across the contact gap.

The latch for the A-C magnet is shown at D in Fig. 5. It is supported on the stop bracket for the rear magnet where it interferes with closing movement unless it is magnetically retracted. Leakage flux from the magnet, when it is energized in the open position, retracts the latch. When the magnet has fully closed, the flux leakage disappears and the latch falls back against the magnet armature plate. It is then in position to drop under the plate and prevent rebounding. Should it be necessary to close the contactor by hand the latch must be pushed aside.

The latch for the D-C magnet is shown at A in Fig. 7. It is mounted beneath an extension of the lower armature plate. In principle, it operates just like the A-C magnet latch. The retracting magnet flux is furnished by a small electro magnet coil B, Fig. 7. The circuit to this coil includes a snap acting switch C, Fig. 7, which is closed only when the armature plate is resting against it. When the main magnet coils are energized, the latch magnet retracts the latch and permits the armature plates to move. This movement opens the switch, cuts off the latch coil current and puts the latch in position to drop under the armature plate and prevent rebounding.

ELECTRICAL INTERLOCKS

Each contactor is provided with auxiliary electrical interlock contacts E, Fig. 5, which will control four independent circuits. All of these may be normally open, or all normally closed, or any intermediate combination of normally open and normally closed. Selection of circuit arrangements is optional.

MECHANICAL INTERLOCKS

Mechanical interlocks, Fig. 9, are used to prevent two contactors from being closed simultaneously. These clamp around the operating shafts and project through openings in the end frames. Rods and fittings fastened to these projecting parts serve to transmit motion of one contactor to a corresponding point on the other where adjustments can be made. Adjust so that there will be no binding at either contactor and when one set of contact touches, the other set cannot be made to touch. When one set of contacts is fully closed, adjust for only enough movement of the other set to prevent binding of interlock parts.

When a spring closed contactor is interlocked with one or more magnet closed contactors, adjust the connecting rod lengths to exactly fit their lever arms when both sets of magnets are fully closed.

RECEIVING, HANDLING AND INSTALLING

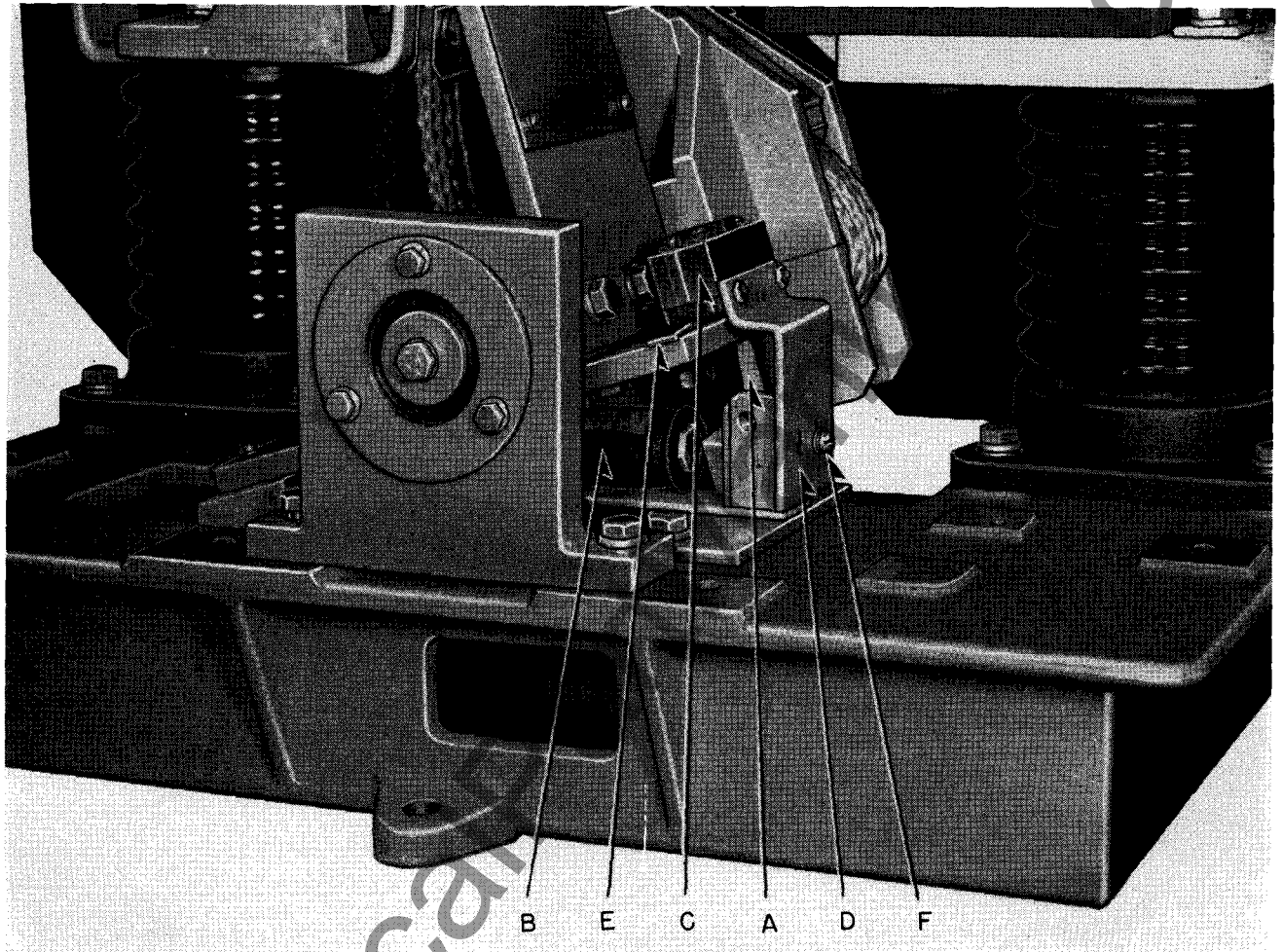

FIG. 7. D-C Magnet Latch

RECEIVING

These contactors are shipped completely assembled, except for the arc chutes and barriers which are packed separately. Immediately upon receipt, make a careful examination for any evidence of damage received in transit. Remove the shipping crate and packing material carefully using a nail puller instead of a hammer or wrecking bar. If any damage is found or suspected, file a claim promptly with the transportation company and notify the nearest Westinghouse Sales Office.

HANDLING & INSTALLING

Exercise care when handling and installing contactors. When lifting, use the lifting eyes provided and an equalizer bar or spreader for the cable sling. Install the arc chutes by rotating them carefully

into a vertical position. Make sure that the blades of the arc runners enter the contact jaws attached to stationary parts without fouling. Barriers should be installed between poles and between poles and grounded parts. Lift them far enough to clear the shaft, push them back against the barrier support, then move them down until they rest on the cast base between insulators.

When wiring cables to the blowout coils on the rear side of the contactor, use cable cleats provided. When wiring to the front side, locate cables so that arc boxes may be swung open to expose contact parts for inspection and replacement. Maximum accessibility will be obtained if the cables lead off horizontally to the left end or side away from the magnet. Brace these cables securely to prevent movement during the flow of heavy fault current.

PART THREE

MAINTENANCE AND REPAIR

GENERAL

Regular, systematic, and thorough inspection is recommended at least once a month, or oftener if

CONTACTS

Contacts are exposed and visible for inspection, Fig. 10, when the arc chutes are swung back on

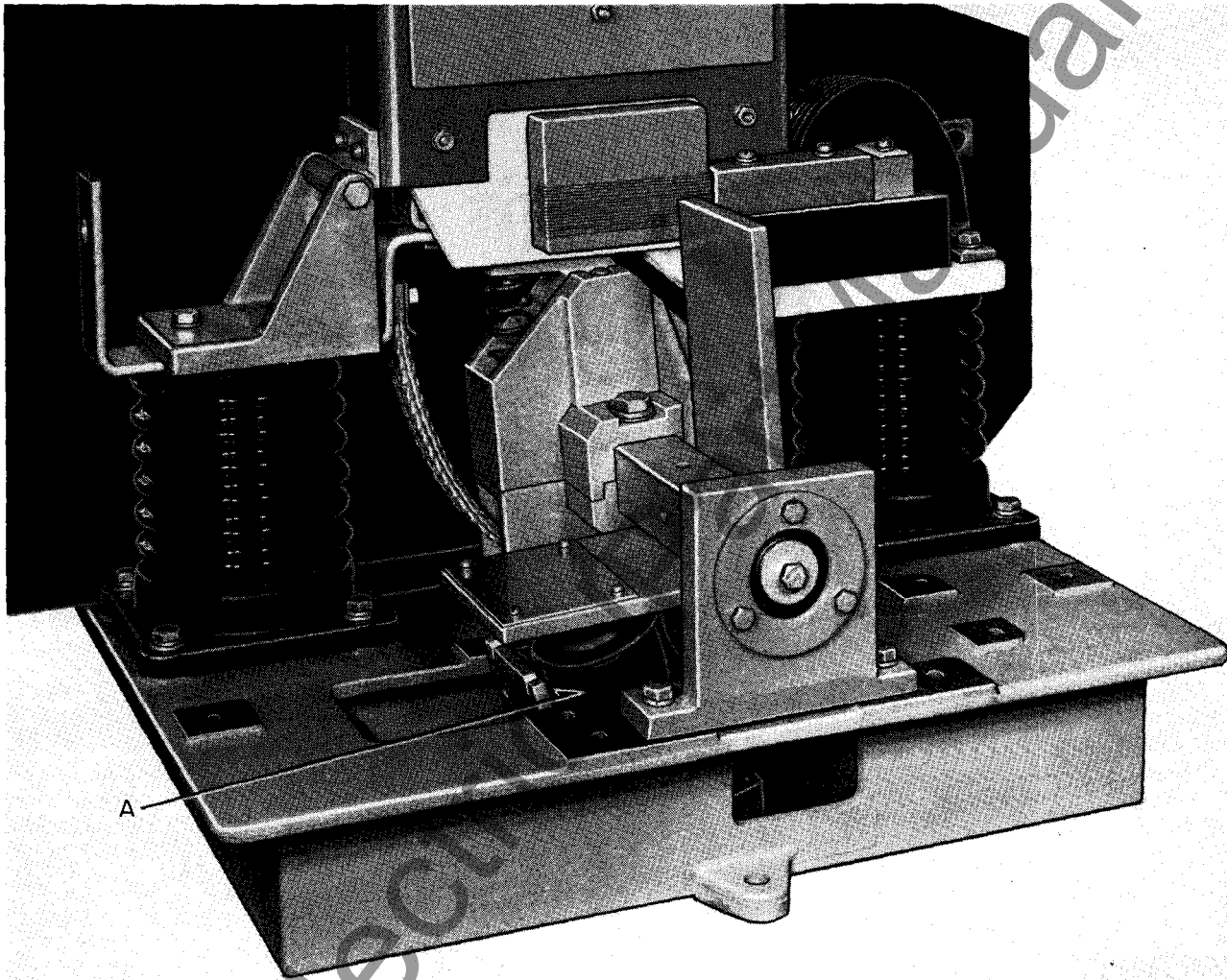

FIG. 8. D-C Holding Magnet

the contactor operates on a fast duty cycle. Be sure that the contactor and magnet are disconnected from all electric power before inspecting or repairing.

Keep the contactors clean, free from dust, water, oil or conducting material. Blowing off with compressed air at monthly inspection periods is recommended. If located where conducting dust is prevalent, more frequent cleaning is necessary.

their hinges. No special tools are needed to remove contact bolts. When replacing contacts, make sure that they fit down over the tenons on their supports and rest flat against support surfaces. Tighten bolts firmly until lock washers are fully compressed. All contacts should touch at nearly the same time. The allowable variation is $\frac{1}{32}$ ". Do not fail to swing arc chutes into place and re-install barriers.

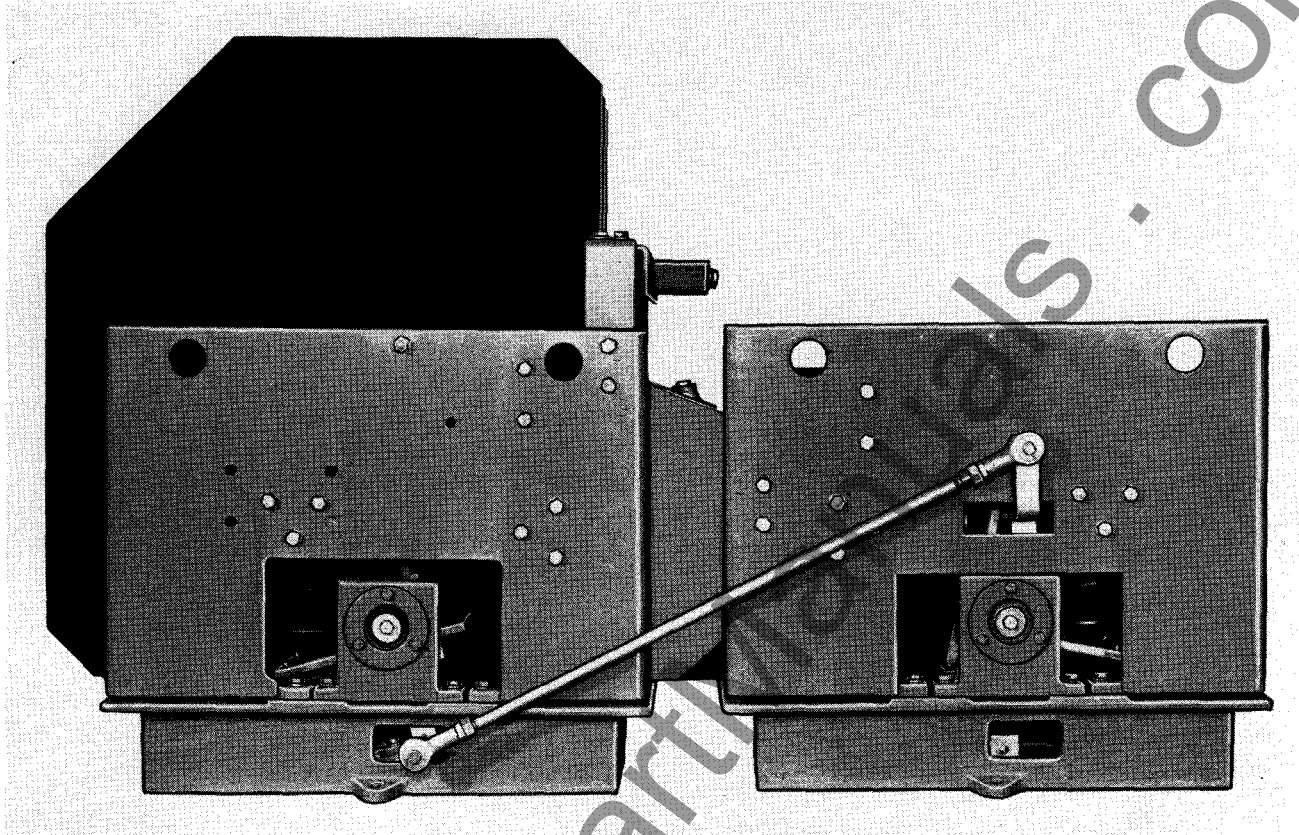

FIG. 9. Mechanical Interlock

SHUNTS

To replace shunts, Fig. 10, remove contacts, disconnect stationary ends of shunts by removing bolts A, remove contact hinge pin screws B, and withdraw the assembly of contact support and shunt. Shunt fastening bolts may then be removed.

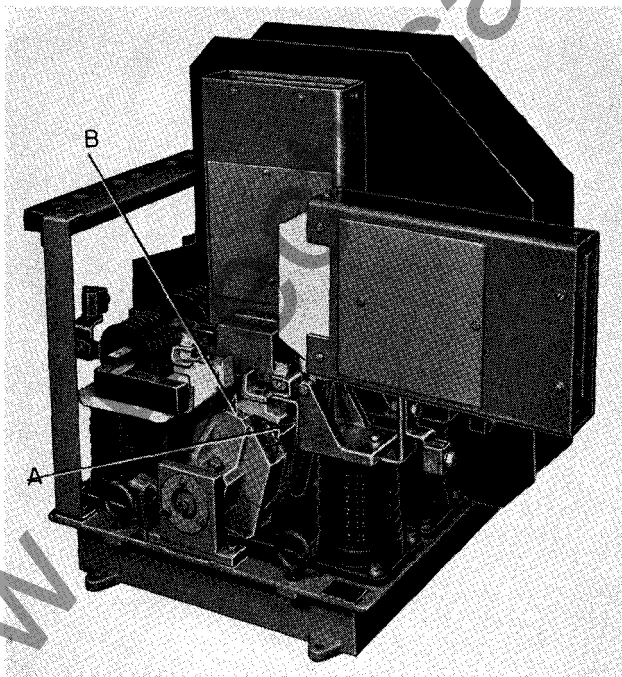

FIG. 10. Open for Inspection

REPLACING COILS—D-C MAGNETS

Disconnect leads from terminals and remove the bolts which hold the magnet cores to the right angle support brackets. Core and coil will then come off together. When replacing coils, the end which has a taped lead running across its face should be placed at the outer end of the core (end farthest from right angle support). The cushion washer should be placed at the other end, next to the support. Be careful not to pinch the washer between the core and support. Reconnect as before and check wiring to be sure of correct magnetic polarity which is not the same for both coils. Polarity will be right when the terminal nearest the end of one coil is connected to the same point as the opposite terminal on the other coil.

MAINTENANCE AND REPAIR.

Coils for D/C holding magnets A, Fig. 8, (when used) can best be removed by taking off the entire holding magnet. When replacing, assemble coil end with taped lead at the end of the core farthest from the angle frame. Polarity connections for this coil are not important.

REPLACING COILS—A-C MAGNETS

Disconnect leads from the terminals. For the front magnet F, Fig. 5, which is suspended from a bracket on the end frame, remove the stationary magnet and bracket together by taking out four bolts which secure the bracket to the end frame. The coil can then be replaced by removing the two bolts and a metal strip G, Fig. 5, fastening the coil to the magnet. When reassembling these bolts and strip, turn the strip so that its wider side is toward the outer edge of the coil.

For the rear magnet M, Fig. 5, which rests on the contactor base, it is necessary to remove the armature before the coil can be removed. This can be done by taking out two bolts tapped into the shaft. After this, the coil can be replaced as described above.

REASSEMBLY—A-C MAGNETS

When reassembling magnets, make sure that the laminated moving armatures close squarely over the laminated stationary parts with a minimum of overhang. No adjustment can be made on the rear magnet. Adjustment of the front magnet may be necessary to reduce magnet noise. Loosen the four bolts holding the bracket to the end frame, energize the coils and close the contactor. Place a lever preferably of the wood or insulating material, under the moving armature laminations, Fig. 11. Using the

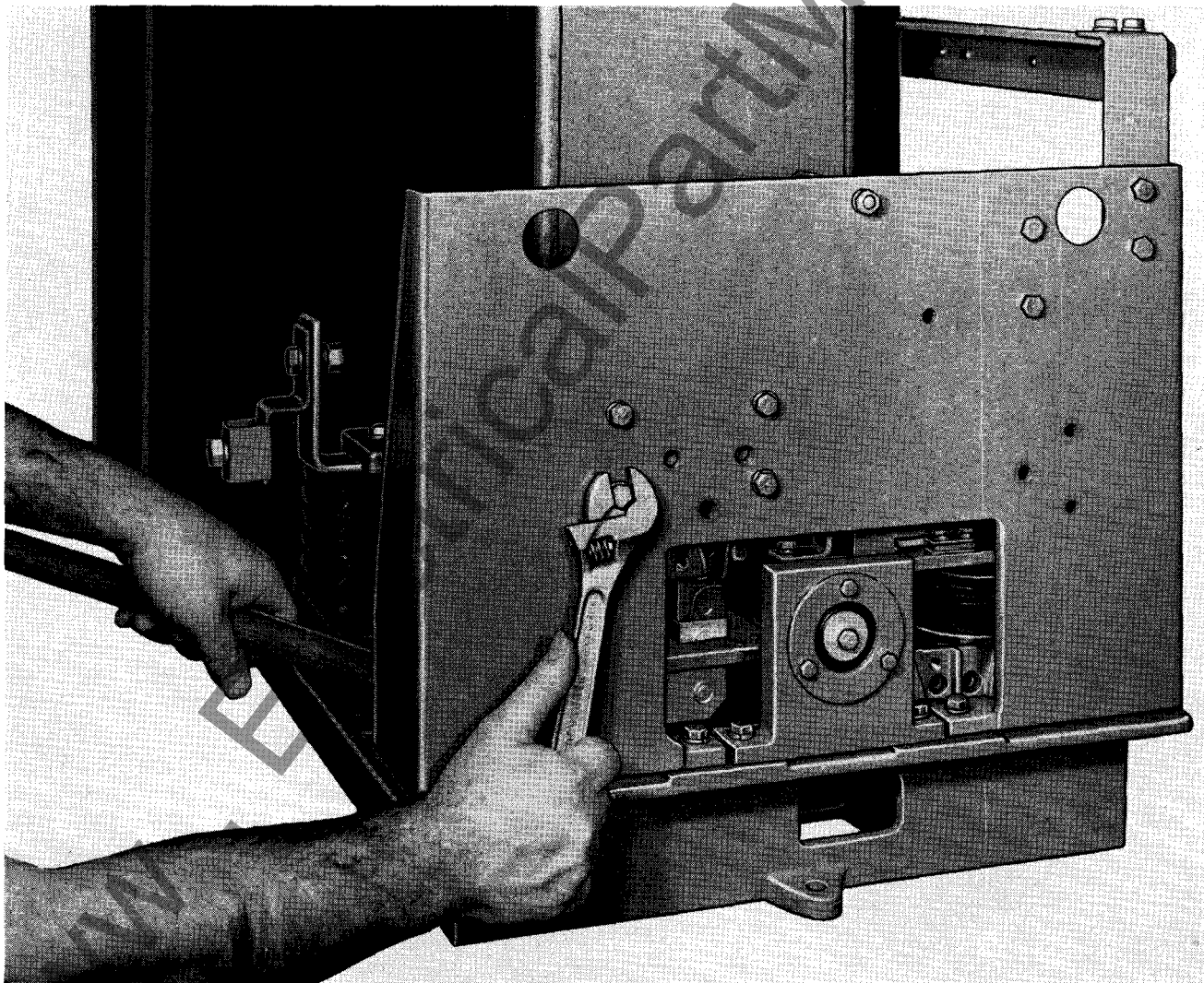

FIG. 11. Adjusting A-C Magnet

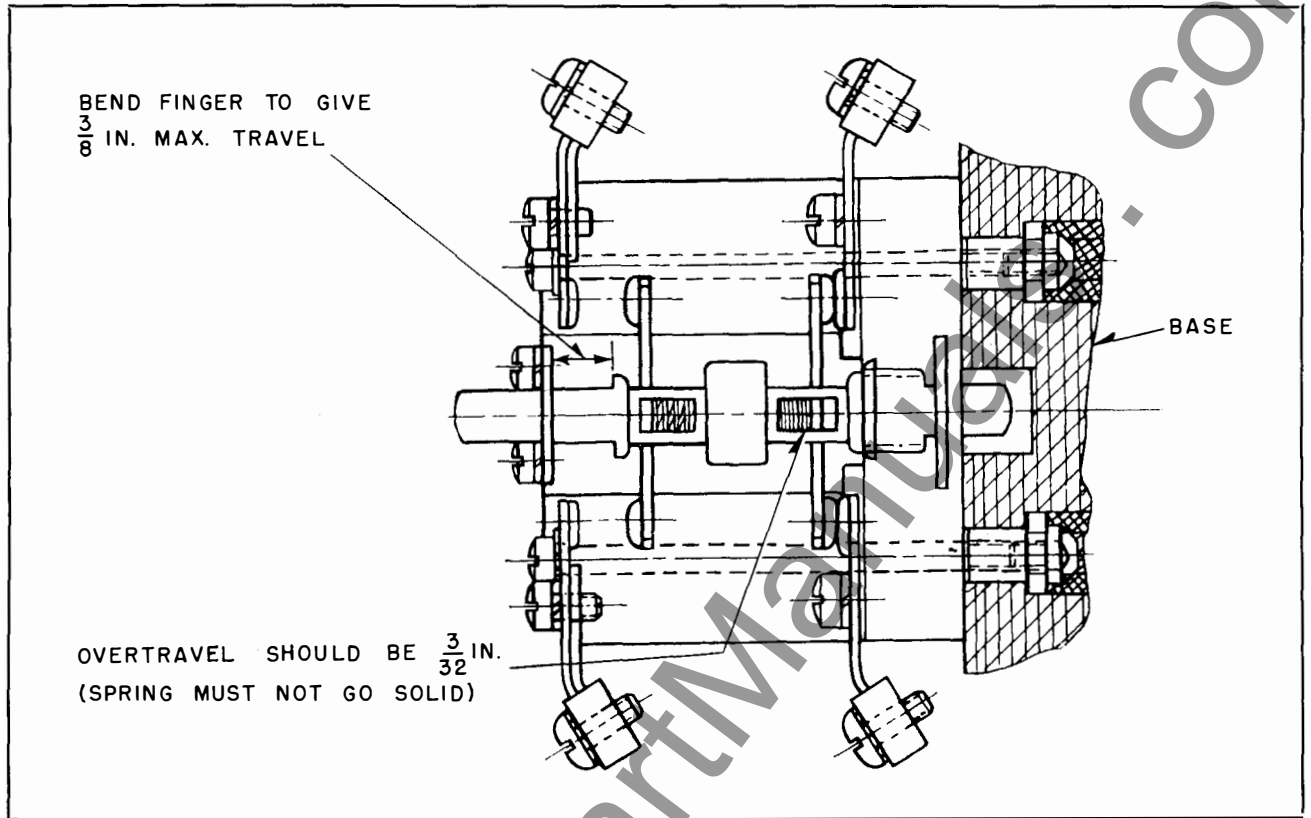

FIG. 12. L61 Electrical Interlock

edge of the cast base as a fulcrum, force the entire magnet upward until noise becomes minimum, then tighten the bracket to the end frame while maintaining pressure against the armature laminations. This should equalize the torque load on the two magnets. As a check, remove the lever and note

whether the space H, Fig. 5, between the moving laminations and the thick armature plate is approximately the same on both magnets. If it is not, the one having the larger space is carrying less than its share of the load. Readjustment may be necessary.

ELECTRICAL INTERLOCK ADJUSTMENT

The L-61 electrical interlocks are operated by movement of arms attached to the contactor shaft. Normal travel adjustment is done by means of adjusting screws J, Fig. 5. Fig. 12 shows where to measure travel and the amount of overtravel to be allowed. Contacts should be replaced when their overtravel is reduced to less than 1/32".

Types H-430A and H-430D—3 pole and type H-450D—5 pole contactors have a hinged operating arm K, Fig. 5, in addition to the arm attached to the contactor shaft. Travel adjusting screws are attached to this arm. Overtravel is controlled by a hexagon headed bolt on the interlock base. Adjust its height until clearance between its head and the hinged operating arm does not exceed 1/32" when the contactor is fully closed. In this position, it should be possible to move the roller on the hinged arm approximately 1/16" away from the main operating arm.

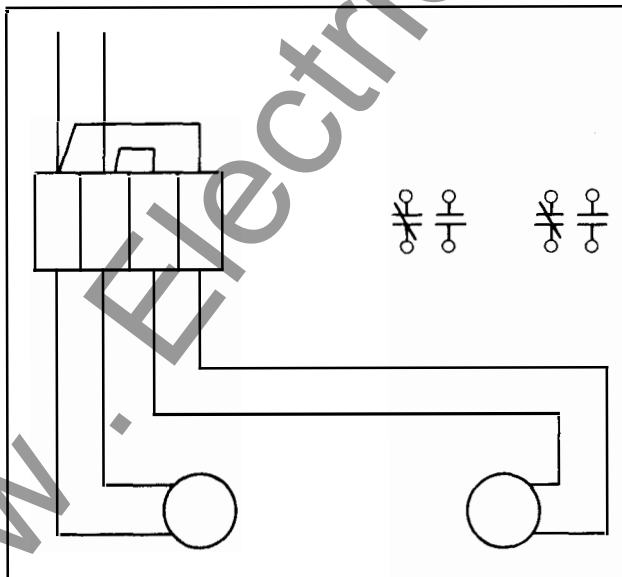

FIG. 13. Connections for A-C Magnet Coils

ADJUSTING MAGNETIC LATCHES

The magnetic latches, as previously explained, obstruct continued movement of the contactor armatures until the magnet coils are energized. There is a normal clearance of approximately $\frac{3}{64}$ " at the latch point which permits only enough armature movement to insure freedom of latch motion. Latches must move freely to get out of the way before the moving armature strikes them. Parts have been made light and non-corrodible.

Light springs of stainless steel wire normally bias the latches toward their normal latching position. Since the spring force is opposite to the magnetic force retracting the latch, it is important to maintain correct spring force. Care should be used to prevent distortion when removing or handling.

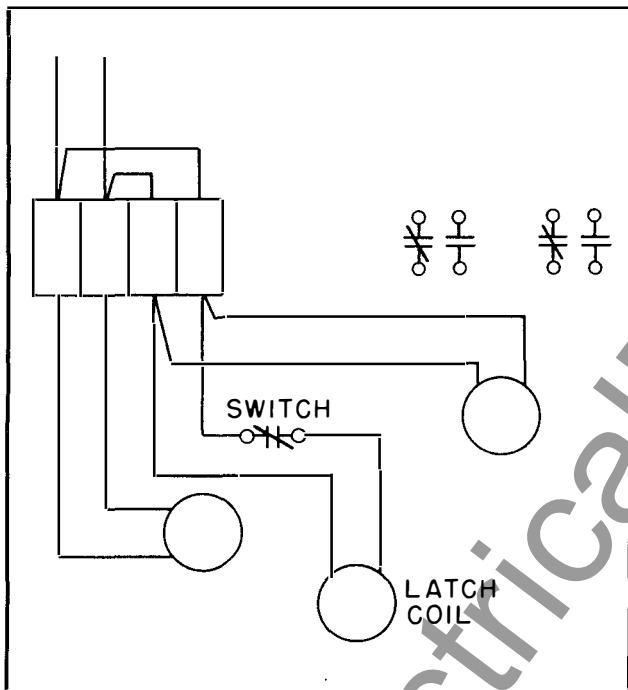

FIG. 14. Connections for 3 pole D-C Magnet Coils

The A-C magnet latch operates from the same magnetic flux that closes the contactor. A small adjusting screw controls the pickup of the latch. Factory adjustment of this screw should not be changed.

The D-C magnet latch operates from a separate small electro magnet. Its cutoff switch must be located accurately in order to close only when the armature is near its full open position. The small bracket on which the switch is mounted is provided with slotted holes D, Fig. 7 which allows a small up and down movement. To adjust switch position, place a $\frac{1}{32}$ " thick shim between the black switch

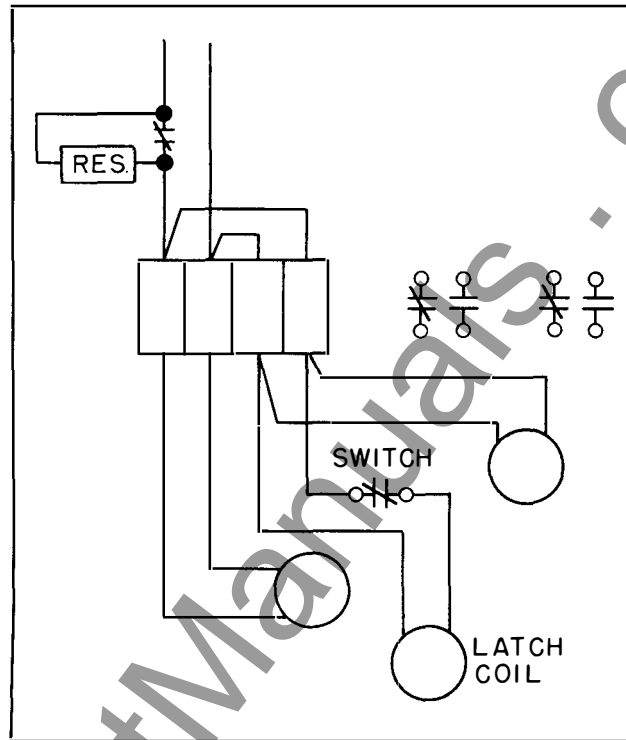

FIG. 15. Connections for 5 pole D-C Magnet Coils

operating button and the armature at point E, Fig. 7, then tighten screws F and remove the shim.

This switch has two circuits identified by diagrammatic symbols moulded in its case near the terminal screws. Use the circuit which is normally open and shown by symbol $\dashv \dashv$.

ARC CHUTES

Only the best and most suitable materials have been used in the efficiently designed arc chutes. Those in the direct path of the arc are non organic. Parts exposed to the high voltage arc are zirconium

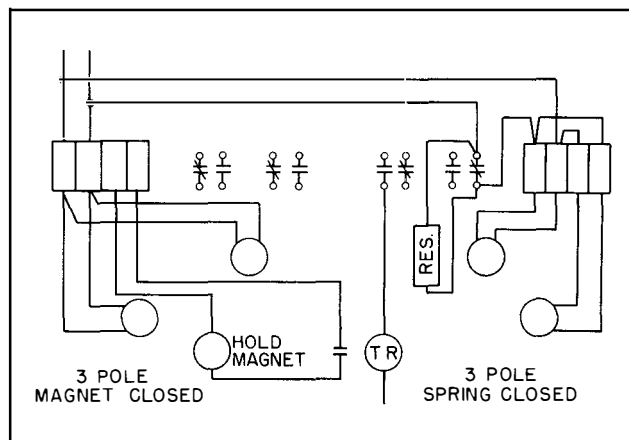

FIG. 16. Connections for D-C Magnet Coils—
Synchronous Dynamic Braking Service

refractories proved by years of experience in Westinghouse contactors and air circuit breakers.

These materials are not burned by the intense heat of the arc but fuse and become glazed over on the surface. After prolonged use, or after interruption of heavy fault current, there may be enough erosion to require replacement. This should be noted especially at the narrow upper end of the slots in the arc stacks. When the upper end of the slot becomes enlarged beyond $\frac{3}{16}$ " diameter, the stack should be replaced.

The insulating parts of the arc chute remain in the circuit across the contacts at all times. During the time that the contacts are open, these insulating parts are subjected to the full voltage across the contactor. Ability to withstand this voltage depends upon the care given the insulation.

During general inspections, blow out the arc chute with dry compressed air directed upward from the contact area and out through each of the slots between the arc splitter plates. Direct the dry air thoroughly over the refractory liners in the lower end of the chute where the arc is drawn.

Periodically a more thorough inspection should be made by removing the arc stacks for cleaning and to permit examination of adjacent parts. Remove any residue of dirt or arc products with a cloth or by light sanding. Do not use a wire brush or emery cloth for this purpose as they may scratch or roughen the surfaces and invite increased future deposits of dirt.

The refractory material in the arc chutes may have a dirty appearance after repeated arc interruptions. This does not necessarily indicate low dielectric strength. If in doubt apply A-C test voltage not over 15 KV for 1 minute, or check insulation

resistance with a megger. Reading should be practically infinite.

DISMANTLING ARC CHUTES

To dismantle arc chutes for inspection, remove 4 fibre blocking strips at upper end, withdraw arc stacks and arc runner assemblies from top of chutes. Refractory liners at bottom end of arc chutes E, Fig. 6, and group of small arc splitter plates D, Fig. 6, near the contacts can be removed through the bottom of the chute. Should it be necessary to remove center arc runners, or blowout coils, remove entire laminated magnetic structure, disconnect the blowout coils at both top and bottom ends then pull the coils upward until clear. Center arc runner plates can then be removed one at a time if they are rotated about one edge until the opposite edge comes out of the rectangular hole in arc chute jacket.

REASSEMBLING ARC CHUTES

Reassemble center arc runners and blowout coils. Reinstall liners and arc splitter plates, assembling them so that slots in adjacent plates are staggered and do not line up with the slots in adjacent plates. Put outer arc runner assemblies in place noting that the narrower runner belongs on the hinge side of the chute. Next insert arc stacks with the side having a rope spacer turned toward the center arc runner. At the same time, make sure that the slot in the plate nearest the center of the chute is directly above the small arc tip brazed to the center runner. Use fish paper shims between the arc runner assemblies and the end walls of the micarta jacket to fill up surplus space. Install the small micarta tube above the blowout coils. Finally, replace fibre blocks to hold the entire assembly together.

MAGNET COIL CONNECTIONS

Figure 13 to Figure 16 illustrate schematically how the various magnet coils should be connected.

Engineering Data

DESCRIPTION	TYPE H-430A	TYPE H-430D	TYPE H-450D	TYPE H-403D
Number of Poles	3	3	5	3
Type of Operating Magnet ...	A-C	D-C	D-C	D-C
Outline Drawing	21C3423	21C3423	21C3424	32B1438
Weight—Pounds	500	500	750	350
Contact Gap—Inches.....	1/4	1/4	1/4	15/16
Contact Pressure—Pounds.....	30	30	30	10
Open Gap Volt Amperes.....	7200	285	460	350
Closed Gap Volt Amperes.....	640	175	175	175
Closed Gap Watts.....	160	175	175	175

RENEWAL PARTS LIST

DESCRIPTION	STYLE	QUANTITY PER CONTACTOR			
		Type H-430A	Type H-430D	Type H-450D	Type H-403D
Moving Contact.....	1780 613	3	3	5	3
Stationary Contact.....	1780 614	3	3	5	3
Shunt.....	1780 669	3	3	5	3
Contact Spring.....	1780 601	3	3	5	..
Arc Chute Complete.....	1780 702	3	3	5	..
Arc Stacks.....	1799 417	6	6	10	..
Auxiliary Arc Plates.....	1799 936	15	15	25	..
Electrical Interlock Complete.....	1486 685	2	2	2	2
Front Stationary Contact.....	1625 818	4	4	4	4
Rear Stationary Contact.....	1745 080	4	4	4	4
Moving Contact.....	1437 667	4	4	4	4
Contact Spring.....	1486 698	4	4	4	4
Push Rod Spring.....	1486 697	2	2	2	2
Contact Spring.....	1780 619	3

* Coils

* Order coils by style number appearing on coil label.

www.ElectricalArtManuals.com

