

# Instructions for A201, A211, A251, Size 2 Magnetic Contactor Non-reversing or Reversing

I.L. 16961  
Model J

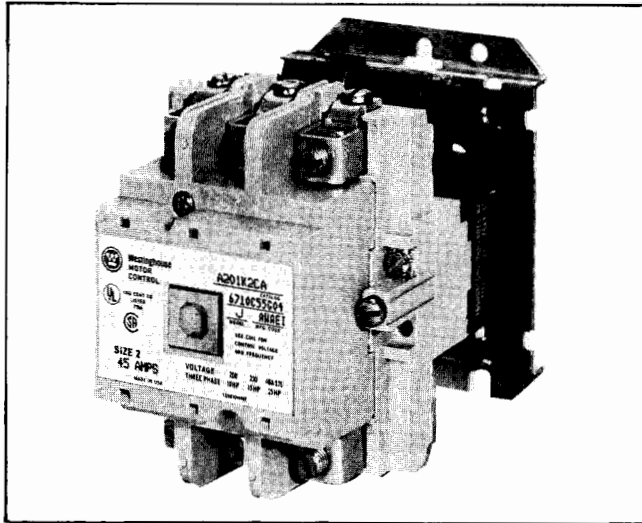

Fig. 1 Size 2 A201 Non-reversing Contactor

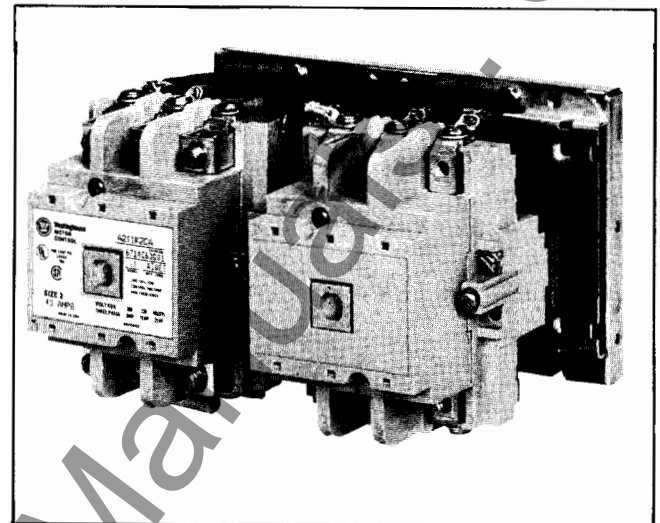

Fig. 2 Size 2, A211 Reversing Contactor

## THE CONTACTOR

A201 contactors are designed for the control of inductive or non-inductive loads at voltages between 120 and 600, AC. The units are suitable for mounting on either steel or insulated panels. All parts are front removable. Contactors should be protected against short circuits by branch circuit protective devices selected in accordance with the National Electrical Code (NEC).

This industrial type control is designed to be installed, operated, and maintained by adequately trained workmen. These instructions do not cover all details, variations, or combinations of the equipment, its storage, delivery, installation, check out, safe operation, or maintenance. Care must be exercised to comply with local, state, and national regulations, as well as safety practices, for this class of equipment.

CONTROLLER RATINGS — 3 POLE CONTACTOR					
Single Phase		Size 2 Horsepower Ratings Three Phase			
115V	230V	200V	230V	380V	460/575V
3	7½	10	15	25	25
Size 2 Current Ratings					
Continuous Carrying Current, RMS (Resistive Load)		Maximum Inrush Current (Amps, Peak, including offset)			
Open	Enclosed				
50A	45A	483A			

Two pole contactors have the same current ratings as 3 pole devices but are not suitable for controlling 3 phase motors.

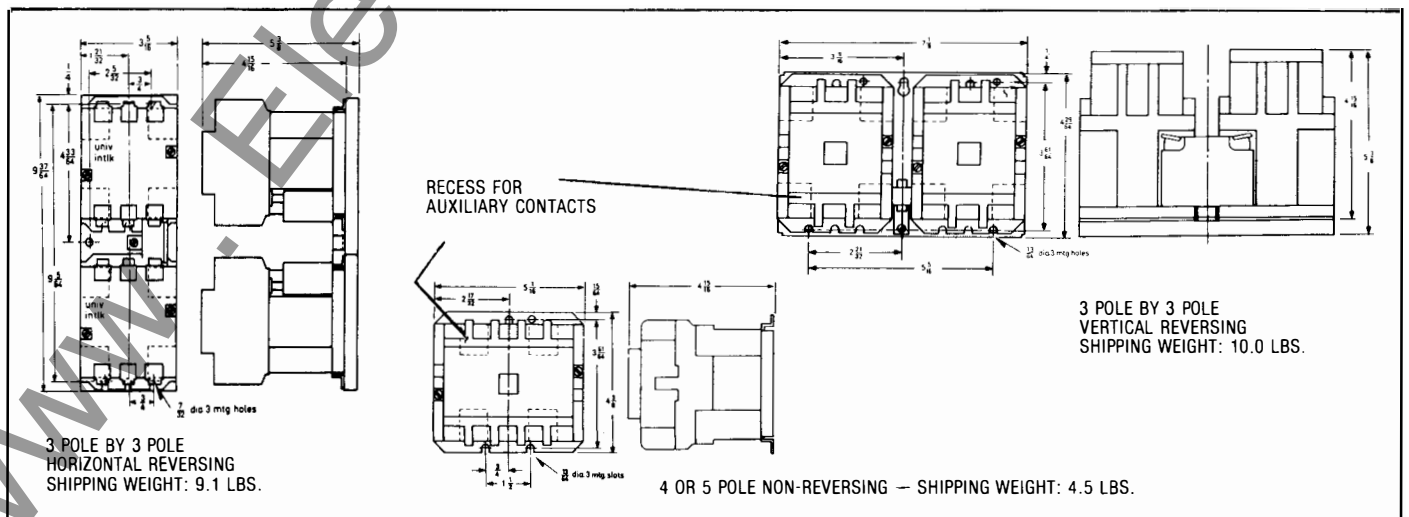

Fig. 3 Dimension Drawings (Dim. in inches)

**AUXILIARY CONTACTS — L56 (RATED B600)**

An L56D with one normally open pole is supplied as the holding circuit auxiliary and is mounted in the upper left hand corner recess of the contactor. A maximum of four auxiliary units can be installed in the recesses of each non-reversing contactor (three in each reversing contactor). These may be mounted with the terminals in line with the power poles or may be mounted with the terminals in a right angle relationship to the power poles. They mount by means of a spring clip which snaps into locations provided in the contactor. To remove the L56 disengage the top spring clip, by pressing on the extended tab, and withdraw the unit.

<b>L56 AUXILIARY CONTACTS</b>		
Contact Type	Catalog No.	
1 Normally Closed	L56E	
1 Normally Open	L56D	
2 Normally Closed	L56C	
2 Normally Open	L56B	
1 Normally Open and 1 Normally Closed	L56	
<b>L56 CONTACT RATINGS (B600)</b>		
AC Volts	Make	Break
24-120	30A	3A
120-600	3600VA	360VA

**COIL**

A201 contactors are available with a single or dual voltage coil. When equipped with a single voltage coil, the contactor is wired as shown in Figure 5. A connection diagram for a dual voltage coil is shown in Figure 4. When supplied with a dual voltage coil, the contactor is normally wired for the high voltage connection. The wiring may be changed to the low voltage connection by removing and reconnecting the jumpers as illustrated below.

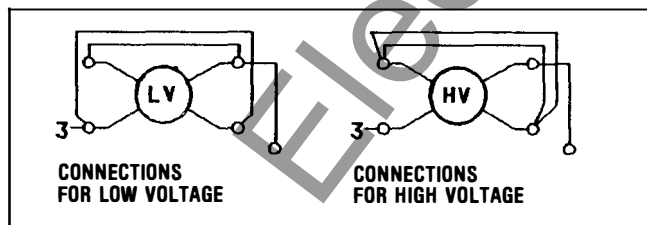

*Fig. 4 Dual Voltage Coil Connections*

**AC COIL DATA, SIZE 2 (TYPICAL VALUES)**

Poles	Inrush VA	Sealed VA	Sealed Watts
2-3	160	25	7.8
4-5	200	30	9.5
<b>Pickup Time:</b> 14—32 ms		<b>Dropout Time:</b> 12—16 ms	

**REPLACEMENT COIL: ORDER BY PART NUMBER, VOLTAGE, AND FREQUENCY**

<b>SIZE 2 AC OPERATING COILS</b>			
Voltage	Freq.	Part Number	
		2 and 3 pole	4 and 5 pole
24	60	505C806G16	Not Available
120/110	60/50	505C806G01	505C818G01
208	60	505C806G02	505C818G02
240	60	505C806G12	505C818G12
277	60	505C806G18	505C818G16
380	50	505C806G07	505C818G07
480/440	60/50	505C806G13	505C818G13
600	60	505C806G05	505C818G05
120/240*	60/60	505C806G10	505C818G10
240/480*	60/60	505C806G03	505C818G03

\* Dual Voltage Coils. Use only on starters originally supplied with a dual voltage coil.

**MECHANICAL INTERLOCK**

The Type M-33 and M-34 mechanical interlocks are used when a pair of contactors must be mechanically protected against the closing of one when the other is already closed. The two contactors may be mounted side-by-side (A211, horizontal configuration) or one above the other (A251, vertical configuration). The two contactors may be any combination of pole arrangements. Type M-33 mechanical interlocks are provided with A211 reversing contactors and Type M-34 interlocks with A251 reversing contactors. These interlocks occupy one recess in each contactor.

<b>POWER CIRCUIT TERMINALS</b>	
NEMA Size	Wire Size
2	#10 - 3 AWG
Wire with copper conductors only.	

<b>TABLE I — ACCESSORIES</b>		
Fuse Block Kits — Meet requirements of NEC concerning common control fusing.		
Order Cat. No.	Qty.	Description
F56	2	Contactor mounted Fuse Holder for 1 600 volt Bussman KTK Fuse
FKR	1	Panel mounted Fuse Holder for 2 Class CC (Bussman KTKR) Fuses*
*Use when available fault current exceeds 10,000 amperes.		
<b>Order Fuses Separately By Ampere Rating.</b>		
Controller Size	Minimum Wire Size in Control Circuit	Suggested Fuse Size†
2	#16 AWG	10 AMP*
†When using a control transformer, select fuse size per the National Electrical Code.		

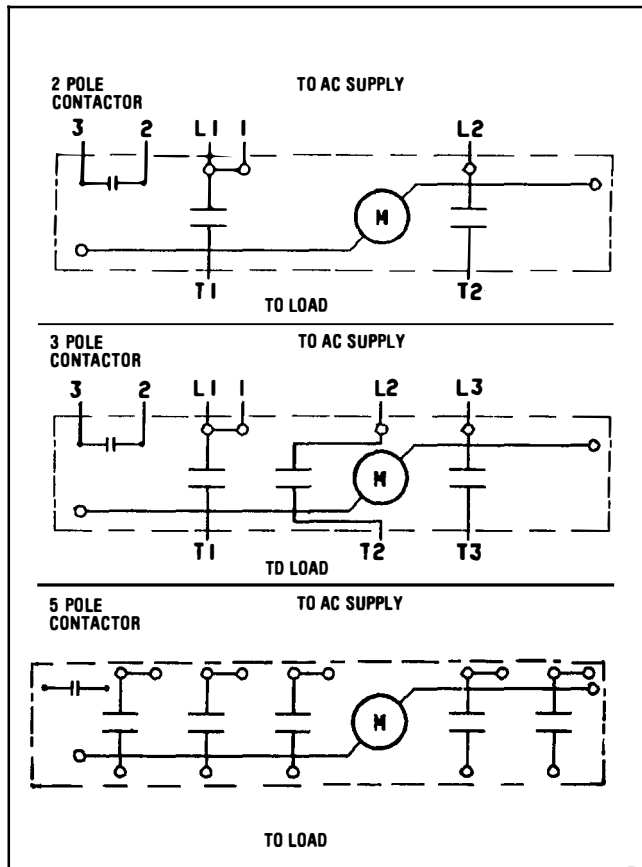

Fig. 5 Connection Diagram, A201

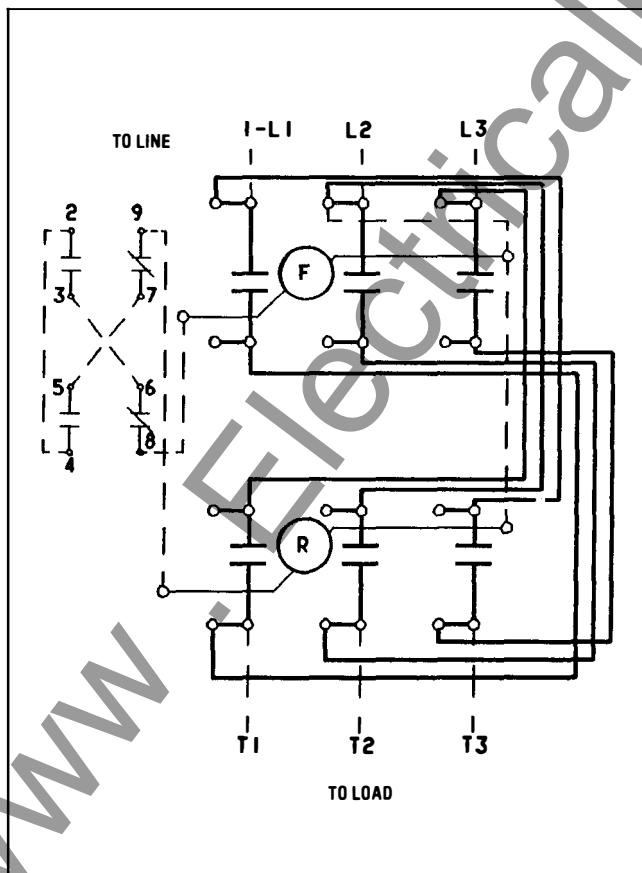

Fig. 6 Connection Diagram, A251

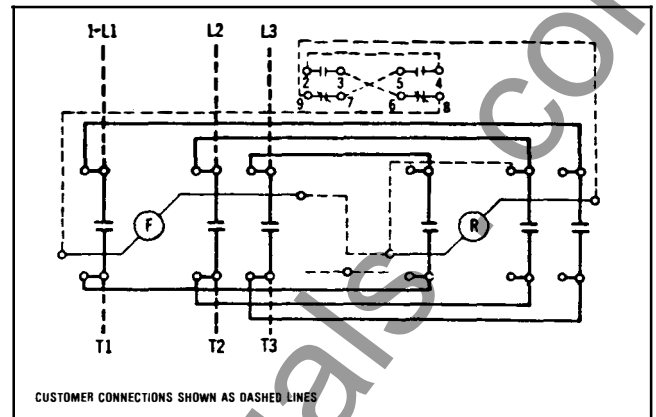

Fig. 7 Connection Diagram, A211

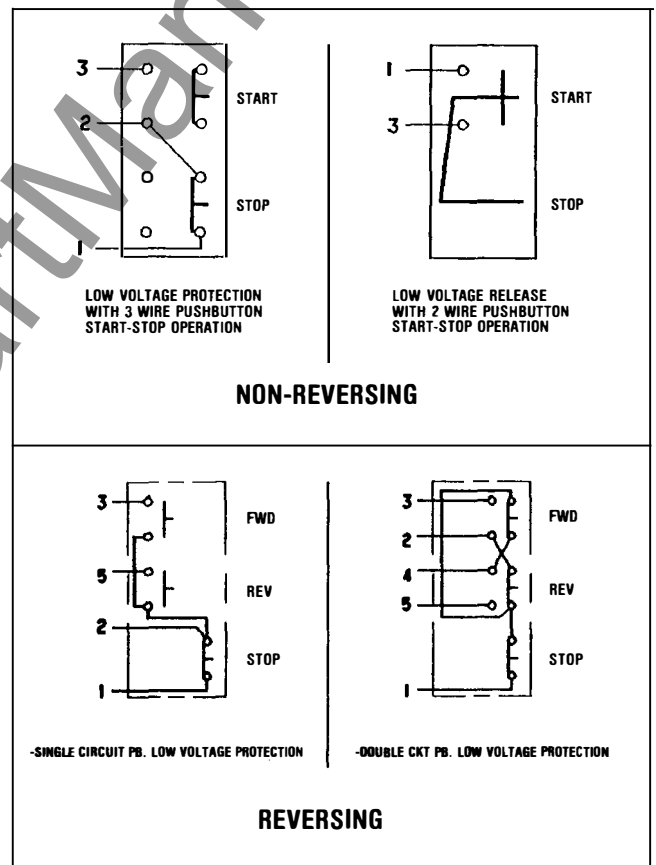

Fig. 8 Control Station Connection Diagrams

TABLE II — RENEWAL PARTS	
<b>Contact Kit Pole Combination and Size</b>	<b>Part Number</b>
2 Pole Size 2	373B331G11
3 Pole Size 2	373B331G12
4 Pole Size 2	373B331G13
5 Pole Size 2	373B331G14
<b>Mechanical Interlocks</b>	
For Horizontal Reversing (A211)	M-33-2
For Vertical Reversing (A251)	M-34-2

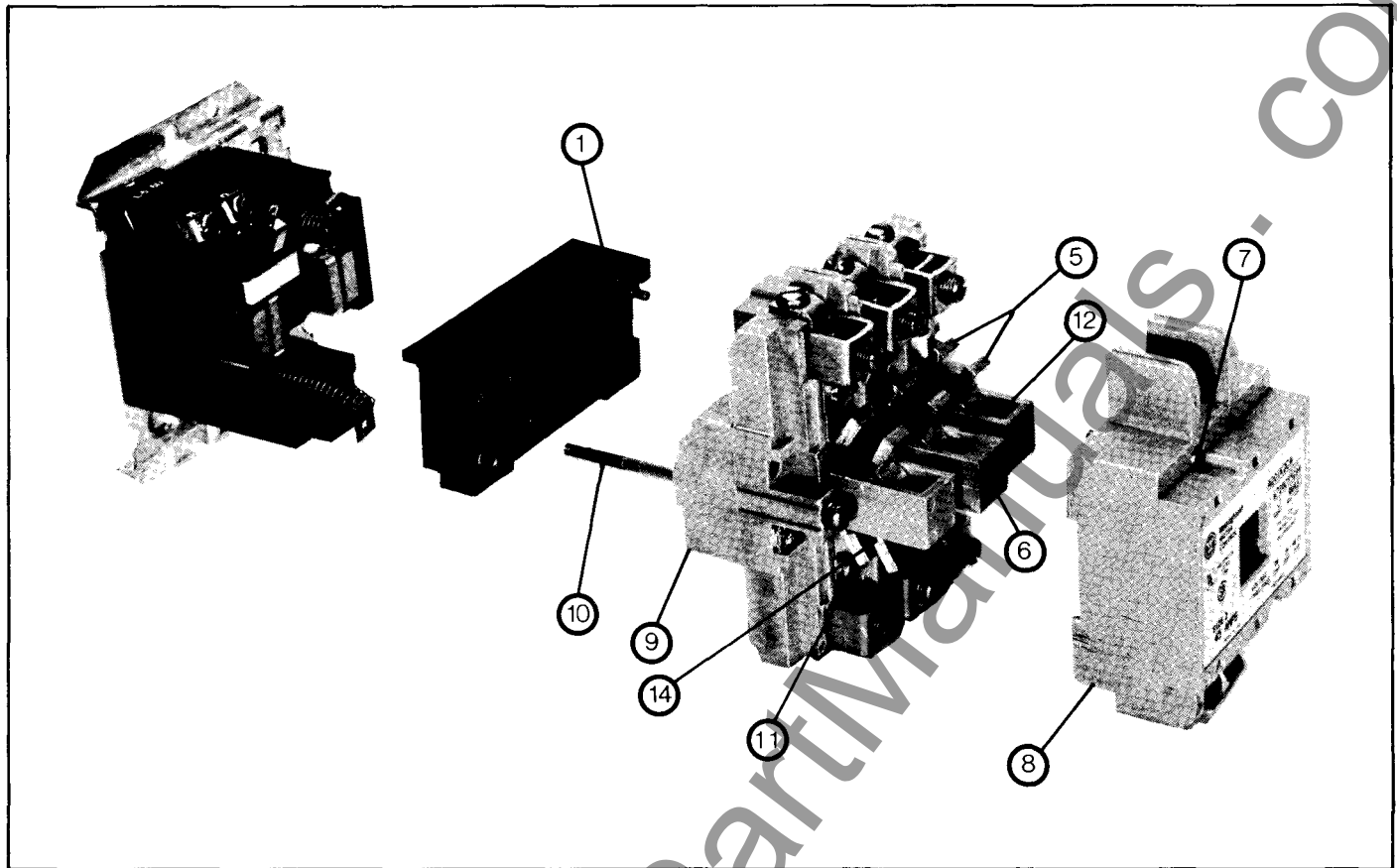

Fig. 8 A201 Magnetic Contactor (Exploded View)

**MAINTENANCE — First Turn Off Power**

**To Inspect Contacts**

Refer to Figure 8. Loosen the two arc box assembly screws (7) located immediately above and below the nameplate and remove the arc box (8). Contacts (5) are visible. Retighten the screws per Table III.

**To Replace Contacts**

After removing the arc box and with replacement contacts at hand, compress the overtravel spring (12) and remove the moving contact (5) from the crossbar (6). Remove the retaining screw (11) and lift out the stationary contact assembly (14).

To replace contacts, reverse the above procedure, making sure that stationary contacts are secure, (see Table III) moving contacts are free to move, overtravel springs are seated and the crossbar moves freely when the arc box is in position.

The silver cadmium oxide contact buttons need **NO** dressing or lubricant throughout their life.

**Important** — Replace all contacts and springs as a group to avoid misalignment.

**To Replace The Coil**

Refer to Figure 8. Loosen the assembly screws (10) located to the immediate left and right of the arc box. Pull the loosened upper base structure (9) forward. Pull the coil (1) from the upper base, plug in a new coil, replace the upper base structure and check the auxiliary contacts for secureness when repositioning the upper base. Tighten the assembly screws referring to Table III.

**Magnet — Armature Assembly**

Self alignment and permanent air gap features of the magnet armature make replacement unnecessary. Mating pole face surfaces should be kept clean.

**Arc box must be in place when the contactor interrupts a circuit.**

TABLE III — RECOMMENDED DRIVING TORQUE		
Location (Qty.)	Driving Torque (lb.-in.)	Fig. 8 Item
Cover Screw (2)	9—12	7
Coil Wire Connector (2)	7—9	13
Stationary Contact Screw (2/pole)	14—16	11
Main Power Connector (2/pole)	40—50	4