

## ELECTRIC BOLT HEATER

The electric bolt heater consists of a transformer equipment and resistance type low voltage heating elements together with ammeters, instrument transformers, cables, etc. It is a compact machine with the parts mounted on a small truck as shown in Figure 1.

The main transformer has a 440 volt or 220 volt A. C. single phase primary winding and is shipped with connections made to suit the station voltage. The normal current rating is 33 amperes at 440 volts and 66 amperes at 220 volts. The transformer will deliver 150% load for 1/2 hour without exceeding the safe temperature rise.

Connected to the main transformer is a small booster transformer with manual switches for cutting it in or out as required. The booster will increase the secondary voltage approximately 25%. The booster is not required for a station voltage of 550, consequently, it is not supplied. The extremely large bolts (over 4-1/2" dia.) require two transformer equipments with the secondaries in series.

A tap changer is provided to vary the secondary voltage from 6.2 volts (open circuit) on #1 tap to 8.5 volts on #5 tap with primary voltage of 220 or 440 and with booster cut out. It is very important that the main switch be opened before moving the tap changer control handle.

The heating element (shown in Figure 2) consists of a nichrome rod brazed to a copper tip at the bottom and a copper terminal at the top. Surrounding the element are mica insulators to prevent contact except at the bottom of the hole. These insulators are important as contact on the side of the element will short circuit it and burn it out. An asbestos handle is attached to the upper end to facilitate handling.

Figure 3 shows, diagrammatically, a heating element placed in a stud. Each element is made to suit bolts (or studs) within a certain range of sizes and should not be used in bolts other than those for which it is intended. As shown in Figure 3, the length of the element must be such that the upper insulators guide it properly in the nut.

When a bolt is to be heated, the terminal on the panel of the machine is connected to the heating element and the turbine cylinder is grounded to the other side of the secondary winding as indicated in Figure 1.

It is usually possible to use one convenient ground connection on the turbine cylinder but for best results connect the ground cable to the turbine cylinder as closely as possible to the bolt being heated and arrange the cables so that they lie closely together.

The cables supplied with the machine are the correct size and smaller cables should never be used because excessive voltage drop will retard the heating rate. A separate ground cable must be used for each bolt being heated and this cable must not be smaller than the cable to the heating element.

The bottom of the hole in the bolt and the tip of the element must be clean. If the current as shown by the ammeter falls off while the element is in use, clean the tip by filing it. The nichrome rod becomes soft when heated and any excessive pressure will bend the element with danger of contacting the side of the hole. The weight of the element alone is sufficient to give good contact when inserted in the upright position. Hence the weight of the cable should be supported independently, and care taken to prevent any side pull which might tend to bend the element.

## Electric Bolt Heater

If the element is used in the inverted position (such as in a stud with the nut at the bottom), an upward pressure of about two or three pounds in excess of the weight of the element should be applied to insure good contact between the end of the element and the bolt. A simple counterbalance should be employed to avoid bending of the element as it expands:

To obtain best results, observe the following:

- (a) The heating elements should be given all the heat they will stand without softening and bending. The maximum safe operating temperature for the element is 1800°F. and at this temperature, the nichrome rod is a very bright orange color. Select the control tap which will produce this color. The color can be observed by opening the main switch and quickly withdrawing the element, just far enough to make the observation. When the required color is obtained, note the ampere reading, which can be repeated without the color observation, on other bolts using the same diameter of nichrome rod.
- (b) As general information, the following ampere ratings will approximate the proper operating temperature.

<u>Diameter Nichrome Rod of Element</u>	<u>Amperes</u>
1/2"	950
3/4"	1250
1"	2000

- (c) During the heating operation, maintain a steady "push" on the light weight wrench, so as to follow up with the nut as the bolt expands. The nut must be kept tight, otherwise, the ground circuit is impaired and the heating retarded.
- (d) Just as soon as a bolt has been stretched the desired amount, and the heating element removed, introduce compressed air to hasten the cooling and thus keep to a minimum the transfer of heat to the flanges. The air cooling is important. A simple air manifold with ten or more branches is suggested, so that an air line will not have to be removed from any bolt before it has cooled.

The sequence of operations must be as follows:

1. Insert element in the bolt
2. Close main switch
3. Permit heating until the desired expansion is obtained
4. Open main switch
5. Remove the element
6. Introduce cooling air

CAUTION - Always open main switch before moving control handle to vary current.

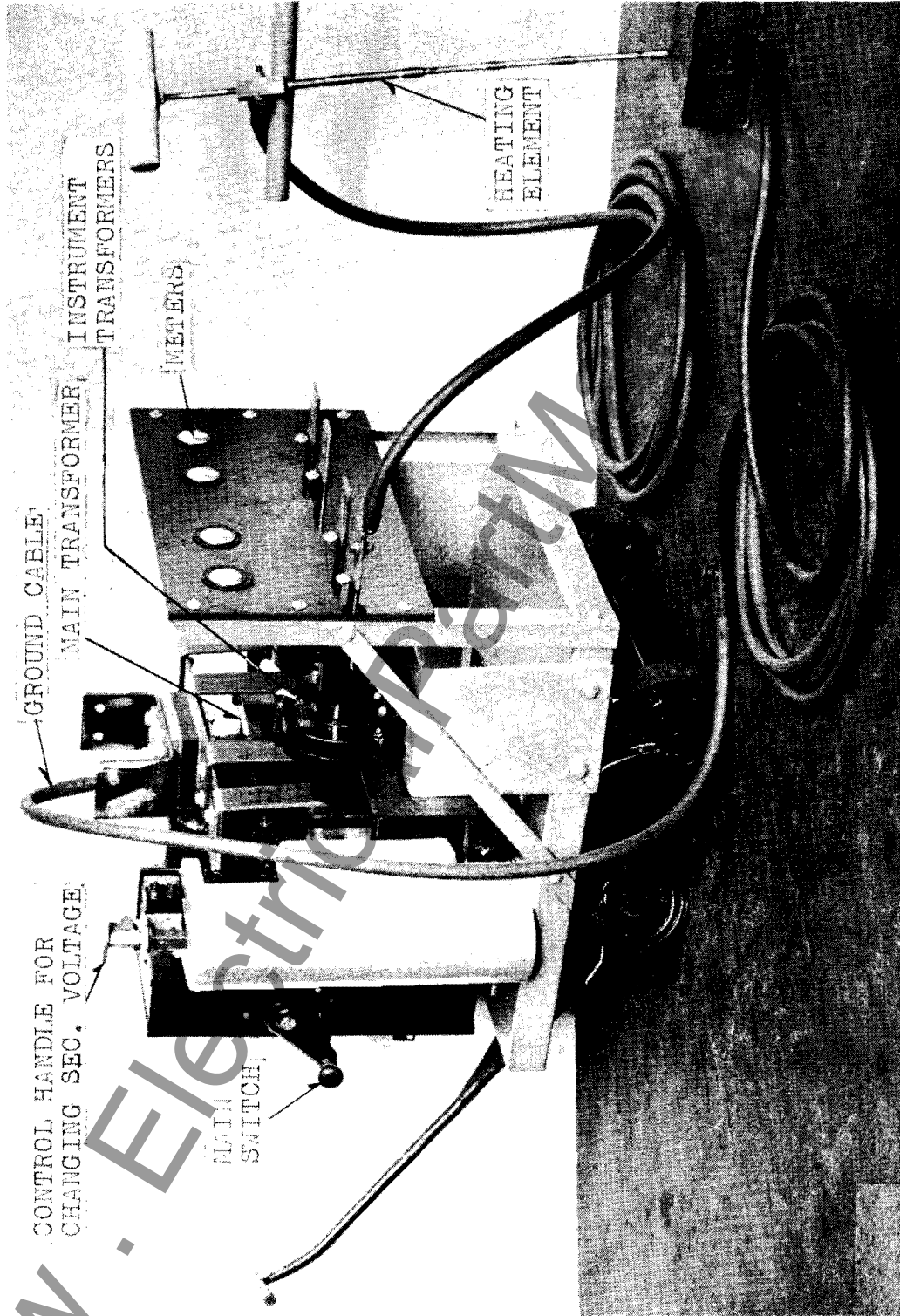

Figure 1

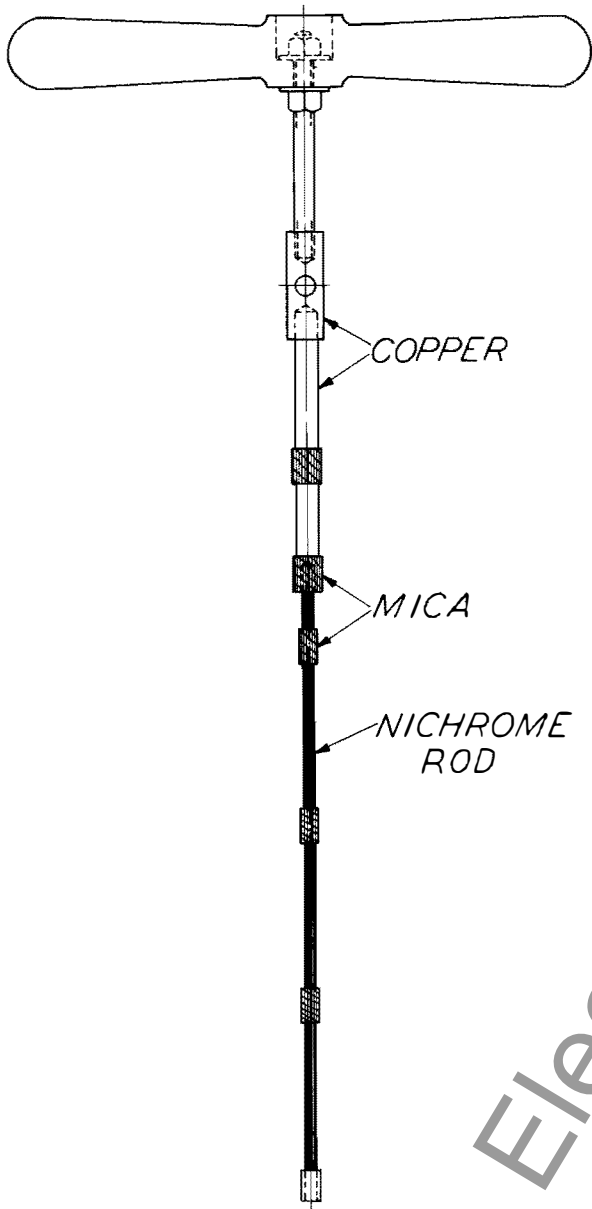

Fig. 2

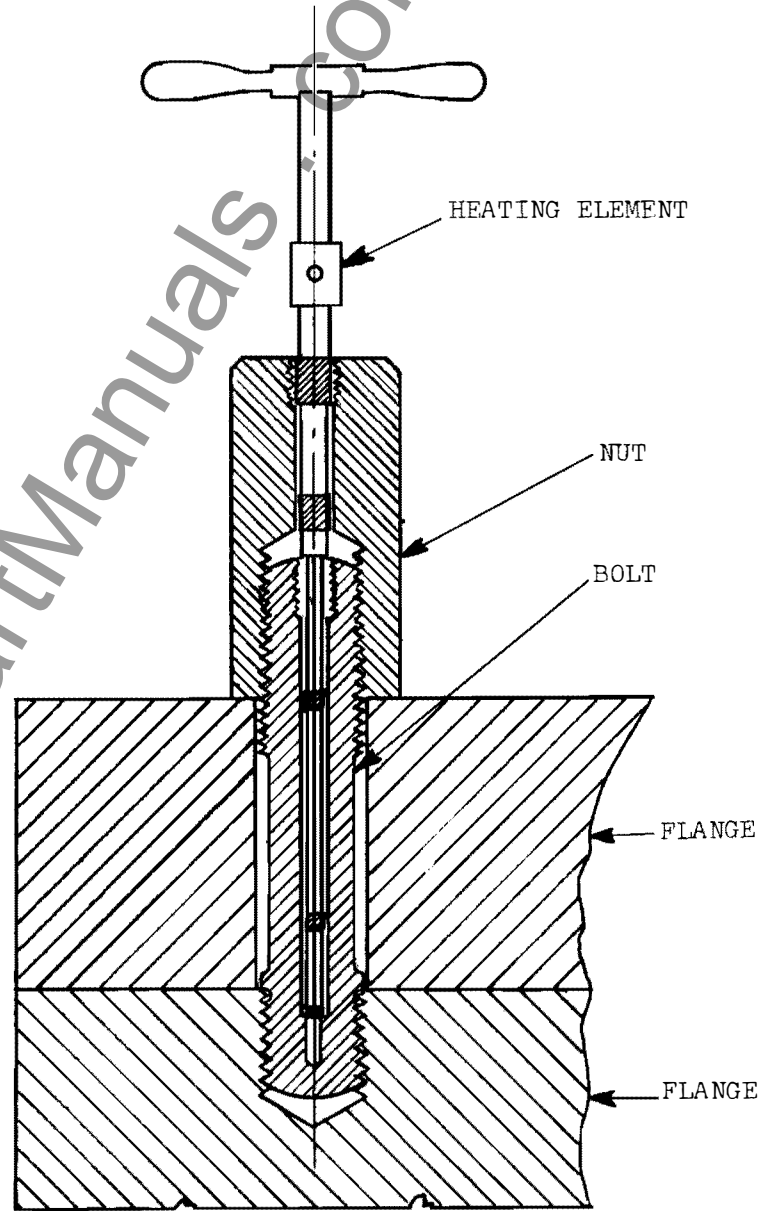

Fig. 3 - Resistance Type Heating Element