

GOVERNOR

The governor is of the vertical shaft, centrifugal type in which the centrifugal force of the weights "16" is opposed by a strap of spring steel and the oil pressure acting above the cup valve "23-A". The governor hub "12" is keyed to the governor spindle "3" which is driven from the turbine rotor shaft extension by the gears "1" and "4". The governor weights are secured to a strap of spring steel mounted across the diameter of the governor hub and clamped by the governor weight stops "15". This strap is formed into an inverted "U" shape at the center and movements of the weights flex the strap thus transmitting movements through the ball "20" to the cup valve "23-A".

The governor spindle and pump drive shaft "3" is supported by the bearings "8" and "9" mounted in the bearing bracket "6". These bearings are the combined radial and thrust type being pressure lubricated through drilled passages in the bearing bracket, a longitudinal groove in each bearing and several radial grooves on the ends of the bearing. The bearing bracket is bolted to the turbine bearing housing.

The thrust clearance can be adjusted by means of the liners "11" which are provided between the governor hub and the thrust collar and between the driven gear and the thrust collar. In addition liners are provided back of the governor gear (driver) for the purpose of obtaining the correct alignment of the two bevel gears.

Pressure Transformer

The essential parts of the pressure transformer are the cup valve "23-A", the housing "22" and the cup valve seat "24".

High pressure oil enters the central chamber or hole of the seat "24" through the strainer "32" and orifice "31". The cup valve seats over this central chamber and controls the flow of oil to the drain, thereby controlling the pressure maintained in the central chamber. This pressure thus maintained by the cup valve is the secondary governing oil or regulating pressure and is connected to the governing valve servomotor to regulate the steam valve opening. Since there is a continuous flow of high pressure oil into the cup valve seat there will also be a continuous flow past the cup valve to the drain in order to maintain equilibrium.

From the above it is evident that upward movement of the cup valve decreases the flow to the drain thus increasing the secondary governing oil pressure. Conversely downward movement of the cup valve increases the flow to the drain thus decreasing the secondary governing oil pressure. As described above the position of the cup valve is determined by the position of the governor weights. Therefore, movements of the cup valve, and hence, the secondary governing pressure respond to changes in turbine speed. In following the operation of this mechanism it is important to bear in mind that the secondary governing oil pressure exerts a downward force on the cup valve at all times, and any change in this pressure results in a change in force acting downward on the cup valve.

In normal operation, the cup valve is balanced by the force exerted by the governor weights acting in an upward direction and the resistance of the strap spring plus the force exerted by the secondary governing oil on top of the cup valve acting downward.

Operation

Briefly a complete cycle of this control is as follows: If the load decreases, the turbine speed increases and the increased centrifugal force of the governor weights moves the cup valve upward. Upward movement of the cup valve increases the secondary governing oil pressure until the increased pressure acting on the top of the cup valve is sufficient to balance the increased centrifugal force of the governor weights.

The increased secondary governing oil pressure thus established by the cup valve acts on the governing valve servomotor causing it to close the governing valve sufficiently to compensate for the decrease in load.

If the load increases, the opposite sequence of events occur to open the governing valve sufficiently to compensate for the increase in load.

Speed Changer

The hand operated speed changer by means of which the turbine speed (or load) can be varied is shown in Section "A-A". It consists essentially of a differential screw "30" which is threaded through the governor housing cover and threaded into the valve seat "24". A guide stud "25" prevents rotation of the valve seat, when the speed changer handwheel is turned. Turning the handwheel "29" in the "Increase" direction rotates the differential screw causing the valve seat "24" to rise thereby increasing the turbine speed (or load). Turning the handwheel in the opposite direction lowers the valve seat thereby decreasing the turbine speed (or load). A stop consisting of items "51", "52", and "53" is mounted on the governor housing cover to limit the upward travel of the screw "30".

When a motor operated speed changer is furnished, the governor housing cover "26" is replaced by the speed changer body "40" as shown in section "E-E". In this case the differential screw "44" is driven through the worm "47" and wormwheel "36" to raise or lower the turbine speed. The faces of the clutch collar "38" and the wormwheel "36" form a friction type clutch which is held in engagement by the spring "35". This clutch slips when the hand operated feature is used.

Adjustment of the Speed Changer

The speed changer is adjusted at the factory and should operate satisfactorily as received. However, if it should become necessary at any time to change the speed changer setting the following outlines the proper procedure.

1. Turn speed changer handwheel in decrease speed (or load direction) several turns.
2. Slowly open the throttle valve and note at what speed the governor takes control, which should be a speed lower than the full load turbine speed.
3. Turn speed changer handwheel in increase speed direction until desired maximum turbine speed is reached. At this speed the locknut "27" and handwheel "29" should be in the position shown in section "A-A", that is the locknut should be tight against the governor housing cover preventing any further turning of the speed changer handwheel. If, however, the desired maximum turbine speed has not been reached when the locknut stops against the housing cover, remove taper pin "28" and handwheel "30". Loosen locknut "27" and then continue to turn the adjusting screw in the increase speed direction with a screw driver until the desired maximum turbine speed is reached.

Governor

4. Lock adjusting screw in this position with locknut "27".
5. Close throttle valve.
6. Remove governor housing cover "26" and see that there is a clearance between the valve seat "24" and the housing cover and also clearance between the valve seat and the shoulder on the adjusting screw.
7. If no clearance exists between the valve seat and the governor housing cover it will be necessary to remove the valve seat guide "25" and turn the valve seat to obtain the clearance. Then replace the valve seat guide and place the cover "26" on the governor housing.
8. Repeat steps, (1), (2), (3), (4) and (5) above.
9. Screw speed changer handwheel on adjusting screw until it contacts locknut "27" then, if necessary drill hole for taper pin "28" through adjusting screw.
10. This will be the upper limit speed changer stop.
11. The low speed limit stop is composed of items 51, 52 and 53 which prevent the adjusting screw from being removed from the housing cover. The upper and lower limit stops on the electric speed changer are determined by the length and position of the stop pin "42".

Adjustments of Governor

The governor is thoroughly adjusted at the factory and should operate satisfactorily as received. However, when reassembling the parts after an inspection, or if it should become necessary to check the accuracy of adjustments, the following points should be noted.

1. The spiral bevel gears "1" and "4" are lapped together in the finishing process, and three mating teeth marked. When reassembling the governor, it is important to see that the single marked tooth on one gear is meshed between the two marked teeth on the gear.
2. Adjust the thickness of the liners back of each of the gears to bring the outer ends of the gear teeth flush and with the back lash at four equal points on gear to be within .002 to .007 inch.
3. Adjust the thickness of the liners "11" to obtain .003 to .006 inch vertical clearance in the governor spindle thrust bearing. The radial clearance of this bearing should be between .003 and .005 inch on diameter.
4. Check distance between end of governor spindle and screw "18". This should not be less than 1/8 inch.
5. Examine cup valve "23-A" for any signs of binding or wear.

The following list has been compiled to facilitate ordering spare or renewal parts by item number and name, together with the serial number of the turbine.

<u>Item No.</u>	<u>Name</u>
1	Governor Gear (Driver)
2	Nut

Governor

<u>Item No.</u>	<u>Name</u>
3	Governor Spindle
4	Governor Gear (Driven)
5	Bearing Bracket Cover
6	Governor Spindle Bearing Bracket
7	Governor Spindle Thrust Collar (Lower)
8	Governor Spindle Bearing (Lower)
9	Governor Spindle Bearing (Upper)
10	Governor Spindle Thrust Collar (Upper)
11	Governor Spindle Thrust Collar Liners
12	Governor Hub
13	Governor Hub Locknut
14	Governor Weight Spring Retainer
15	Governor Weight Stop
16	Governor Weight
17	Governor Weight Support Complete
18	Transformer Cup Valve Ball Housing Screw
19	Transformer Cup Valve Ball Housing
20	Transformer Cup Valve Ball
21	Transformer Cup Valve Insert
22	Transformer Cup Valve Housing
23	Governor Housing
23-A	Cup Valve
24	Valve Seat
25	Valve Seat Guide Stud
26	Governor Housing Cover
27	Locknut
28	Taper Pin
29	Speed Changer Handwheel
30	Differential Screw
31	Orifice Plug
32	Strainer
33	Cover Plate
34	Speed Changer Spring Seat
35	Speed Changer Clutch Spring
36	Speed Changer Worm Wheel
37	Speed Changer Washer
38	Speed Changer Clutch Collar
39	Speed Changer Stop Pin (Lower)
40	Speed Changer Body
41	Speed Changer Socket Head Set
42	Speed Changer Stop Pin
43	Speed Changer Stop Pin (Upper)
44	Speed Changer Shaft
45	Speed Changer Handwheel
46	Speed Changer Bushing
47	Speed Changer Worm
48	Speed Changer Worm Shaft
49	Speed Changer Motor Coupling
50	Speed Changer Motor
51	Speed Changer Stop Stud
52	Speed Changer Stop
53	Speed Changer Stop Spacer

www.ElectricalPartManuals.com

Printed in U.S.A. (3-42)

Figure 1
5

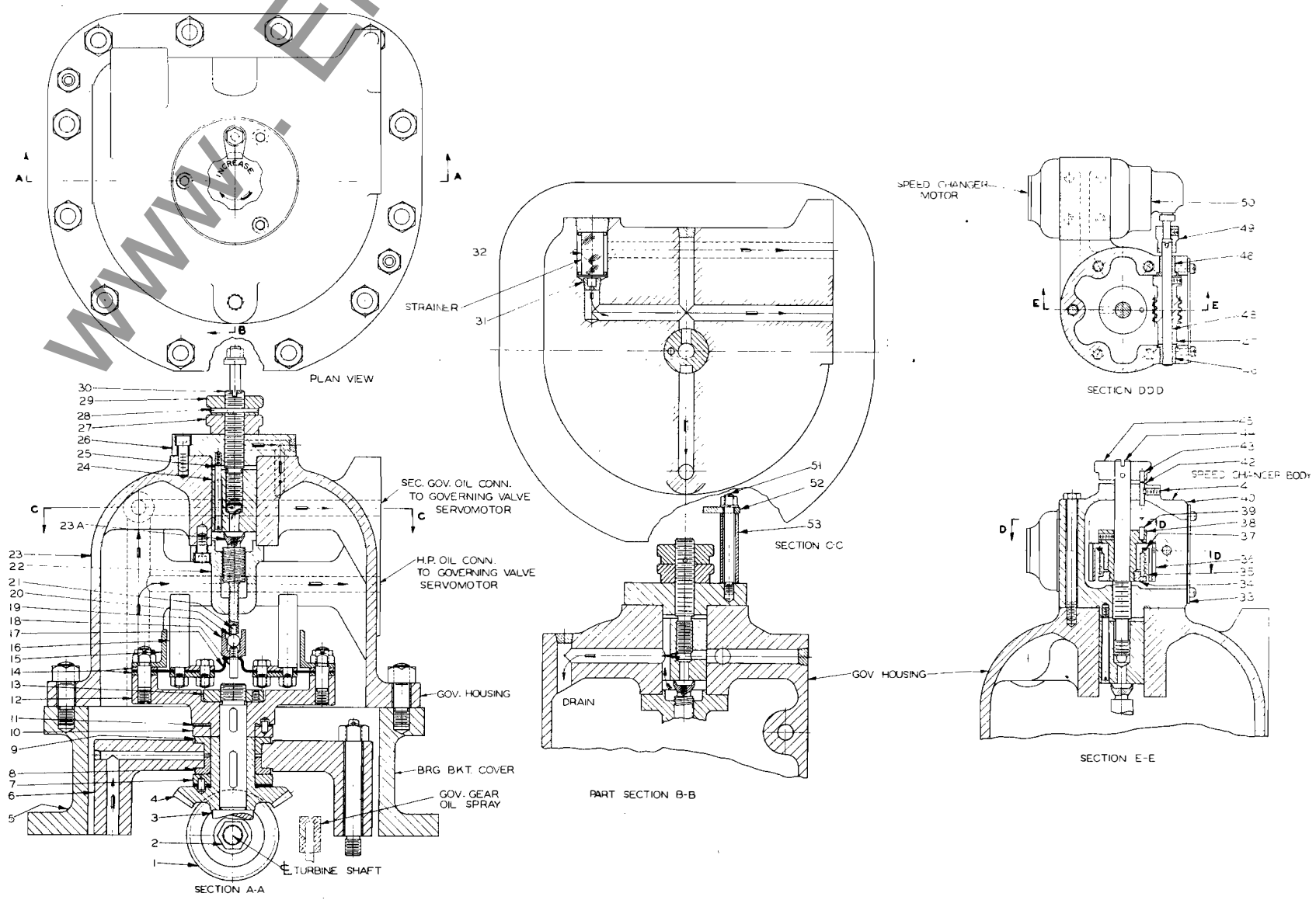

Governor