

September, 1990  
Supersedes Descriptive Bulletin 41-180,  
pages 1-4, dated January, 1989  
Mailed to: E, D, C/41-100A

For Phase Current Unbalance  
Protection of Polyphase Apparatus  
From Phase Unbalance or Phase Failure  
Tapped Type  
Device Number: 46

## Type CM Phase Balance Current Relay

### Application

The CM relay is designed to provide protection against unbalanced phase currents by operating to trip the circuit breaker when a fixed percentage of unbalance exists between any two phases. It will, therefore, protect motors under load when the desired sensitivity cannot be obtained by a voltage operated relay, since polyphase machines tend to maintain normal phase voltage even with one phase open, unless the machine is heavily loaded.

The CM relay is used primarily for motor protection on a three-phase system. It can also be used to detect phase unbalance or open phase. Any applications requiring the detection of phase current unbalance in a polyphase system can use the CM relay.

As shown in Figures 3 and 4, the relay may be used with either two or three current transformers. With two current transformers the accuracy class must be at least T35 or C70. With three current transformers the accuracy class must be at least T25 or C50. Otherwise, current transformer errors during motor starting may cause undesired CM tripping.

### Operation

See Figure 1

#### (Torque Relation and Contact Arrangement)

The CM relay consists of two mechanically independent induction disc units. Usually, phase A and B currents energize the upper electromagnets, while phase B and C currents energize the lower electromagnets. When phase currents are balanced, the electromagnets create equal and opposing torques on each of the discs.

The relay contacts are electrically common and connected in parallel. Closing of any one contact on either the upper or lower disc completes the trip circuit.

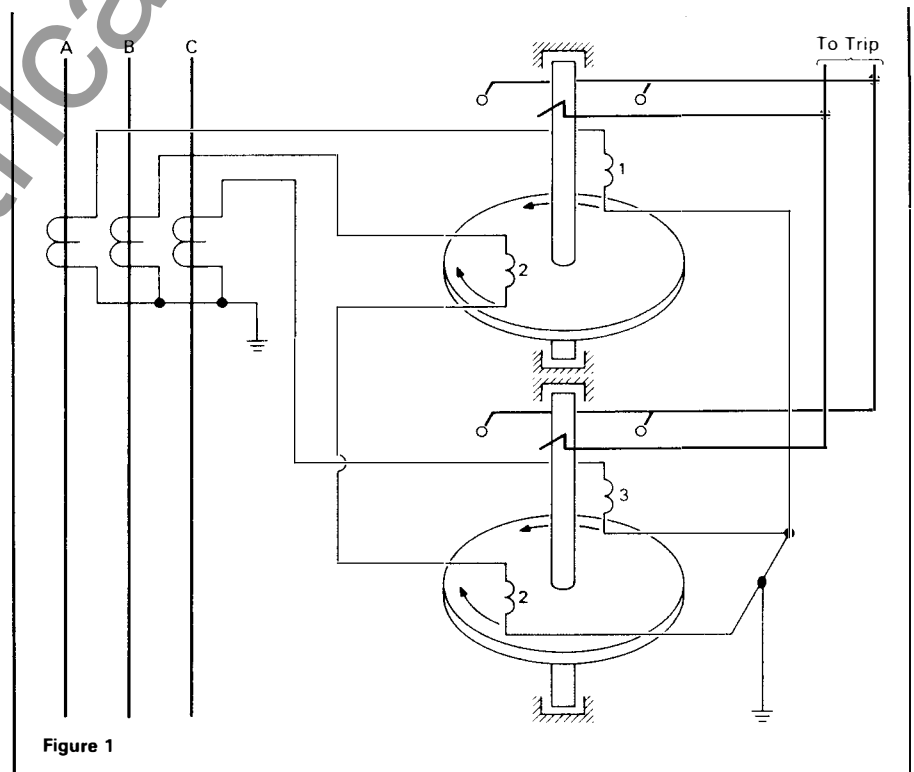
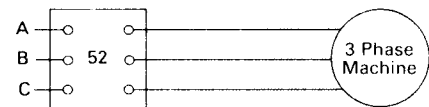
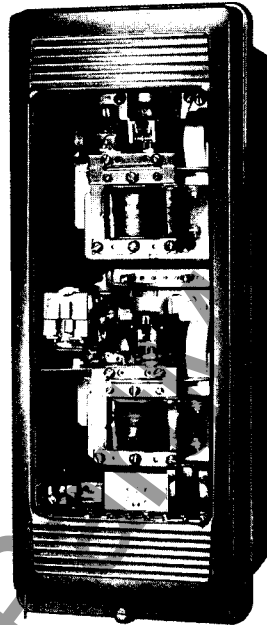

Figure 1

### Construction

The relay consists of two main current units and their associated resistor. An Indicating Contactor Switch (ICS) or an ac Indicating Contactor Switch (ACS) is provided.

- ① Upper Induction Unit
- ② Lower Induction Unit
- ③ Damping Magnets
- ④ Moving Contacts
- ⑤ Left Hand Stationary Contact (Upper)
- ⑥ Indicating Contactor Switch

The dc operated Indicating Contactor Switch has a clapper type magnetic armature to which leaf-spring contacts are attached.

When the switch is energized, the moving contacts bridge the stationary contacts, completing the trip circuit. The ICS contacts are connected in parallel with the main relay contacts, relieving them of carrying heavy trip currents.

The main contacts of the relay will close 30 amperes at 250 volts dc, and the Indicating Contactor Switch contacts will carry this current for sufficient time to trip a circuit breaker.

For 5 amp ACS, the 1-second coil rating is 18.0 amps ac. For 1.0 amps ACS, the 1-second coil rating is 44.0 amp ac.

- ⑦ Tap Block

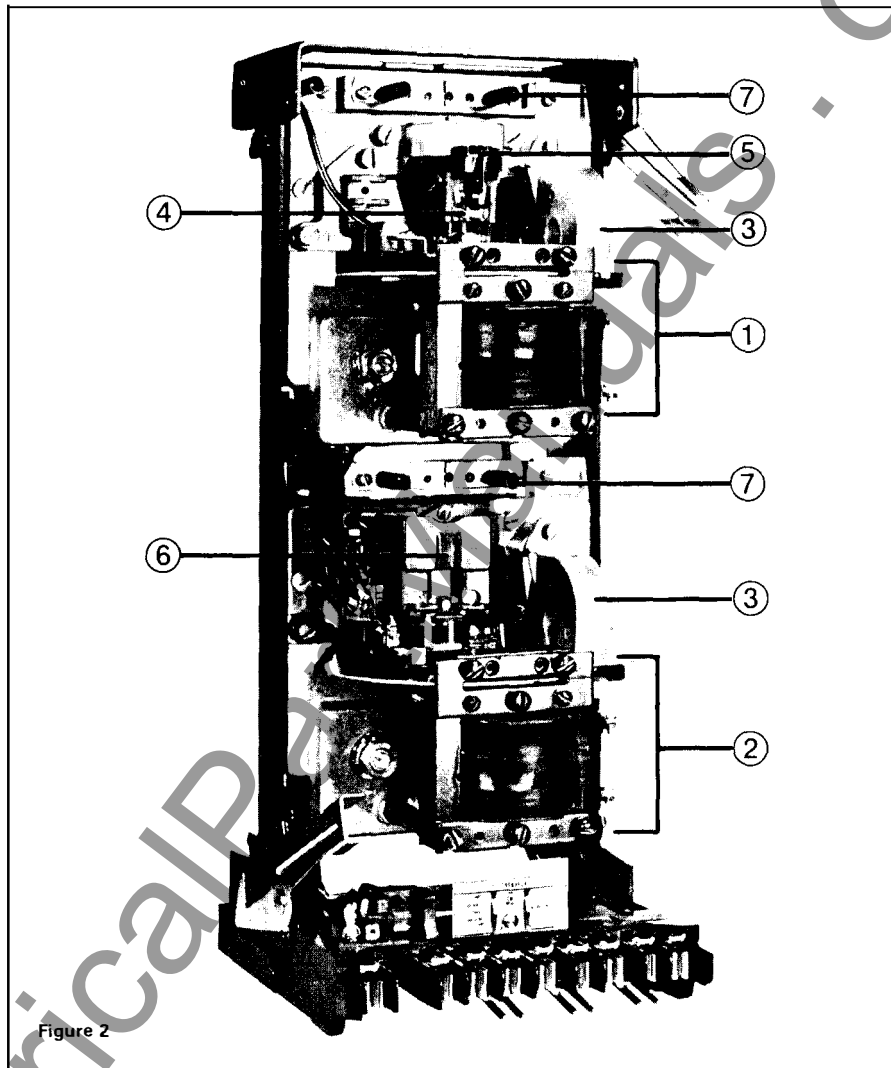

Figure 2

**Maximum Continuous Thermal Rating**  
7.0 amperes

#### Indicating Contactor Switch

Taps on the front of the ICS unit provide connection for either 0.2 or 2.0 amperes dc pickup operation.

When using a 125 or 250 volt dc auxiliary WL (or equivalent) relay the 0.2 amp tap is

recommended. The 2.0 amp tap is used when generating 24 or 48 volt dc circuits.

#### Settings

No setting is required since the unit is calibrated for one ampere sensitivity and is set to operate on an unbalance as shown in Figure 6.

## External Schematic of Type CM Relay

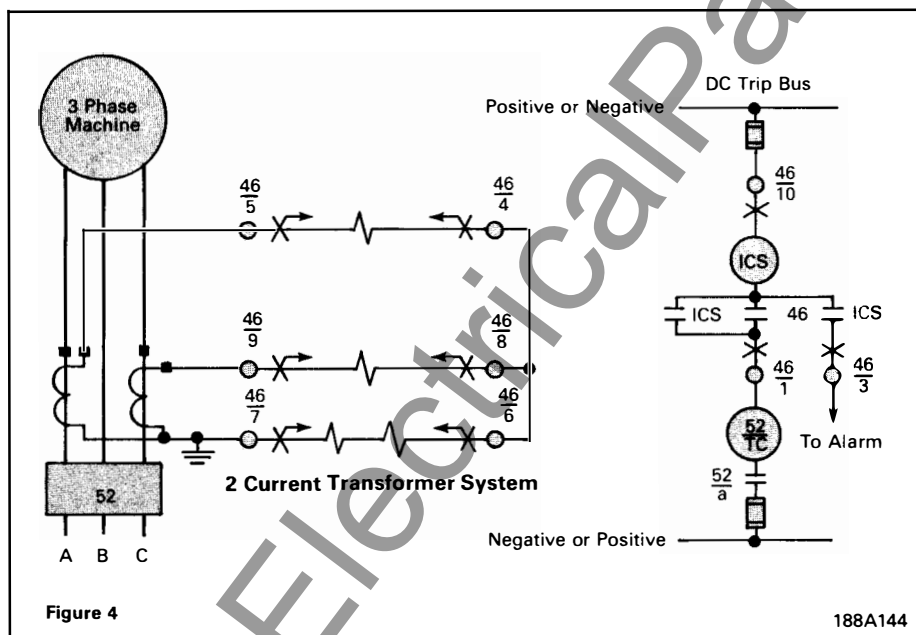
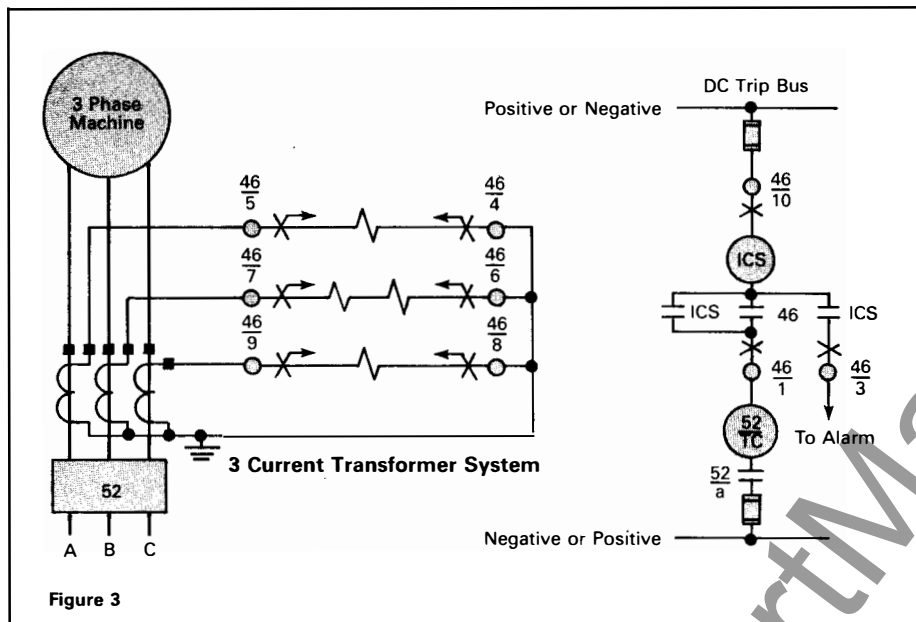

### Characteristics

The tapped CM relay has a minimum pickup of 1, 2, or 3 amperes depending on the tap setting, and a continuous thermal rating of 7 amperes.

The minimum pickup current is defined as the pickup current of each electromagnet, with the other paired electromagnet de-energized.

The relay may be utilized for continuous load currents of from 1 to 7 amperes. See Figure 5.

### Energy Requirements

This table represents the burden on the current transformer connected to terminals 4 and 5 or 8 and 9. The burden of the current transformer connected to terminals 6 and 7 is twice the stated values.

Taps	Current-Amps	Frequency-Hertz	Volt-Amperes	Power Factor Angle
------	--------------	-----------------	--------------	--------------------

#### Tapped Relay

1	1	60	.95	74
1	5	60	15.00	73
2	2	60	.98	65
2	5	60	5.80	65
3	3	60	1.05	54
3	5	60	2.80	54

### Contact Switch

#### Trip Circuit Constants

ICS: 0.2 amp tap – 6.5 ohms dc resistance.

2.0 amp – 0.15 ohms dc resistance.

ACS: 0.5 amp – 18.0 ohms ac impedance.

1.0 amp – 4.5 ohms ac impedance.

### Shipping Weights and Dimensions

Weight, Lbs.		Domestic Shipping Carton Dimensions, Inches
Net	Shipping	
18	25	12 x 13 x 21

### Device Number Chart

46	Phase Balance Current Relay Type CM
52	Power Circuit Breaker
52a	Breaker Auxiliary Contact
52TC	Breaker Trip Coil
ICS	Indicating Contactor Switch

**Characteristics, Typical Operating Curve**

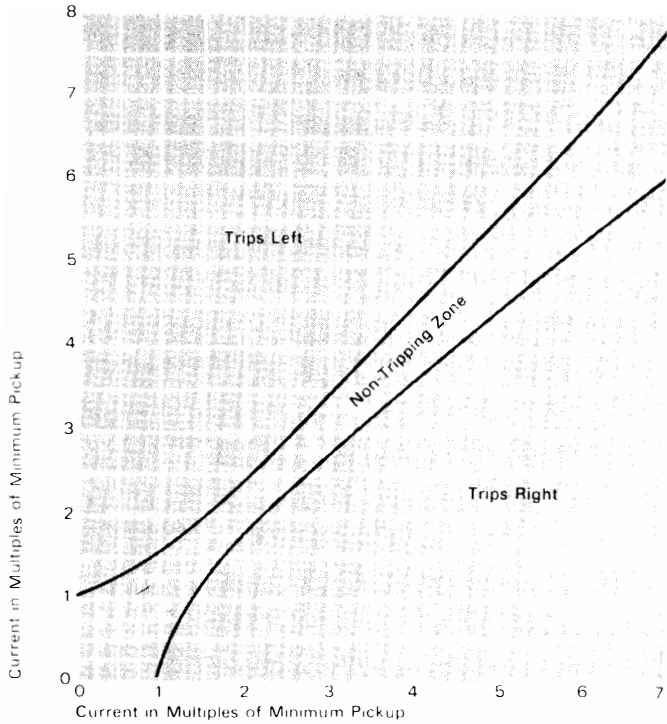

Figure 5 188A145

**Typical Time Curve, With Zero Restraint**

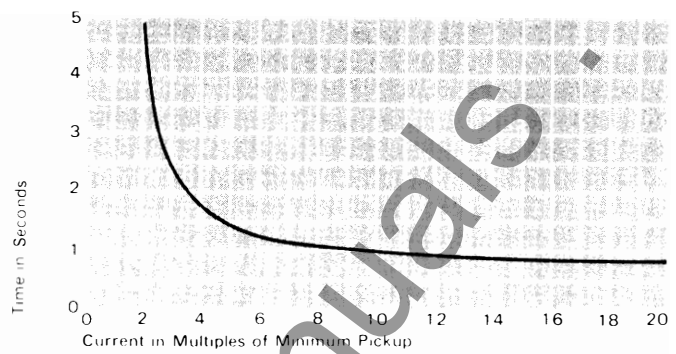

Figure 6 188A146

**Further Information**

- List Prices: PL 41-020
- Technical Data: TD 41-025
- Instructions: IL 41-181.2
- Renewal Parts: RPD 41-911
- Flexitest Case Dimensions: DB 41-076
- Contactors Switches: DB 41-081
- Timing Relays: DB 41-504E
- Other Protective Relays:  
Application Selector Guide, TD 41-016

**Internal Wiring, Front View FT-31 Case**

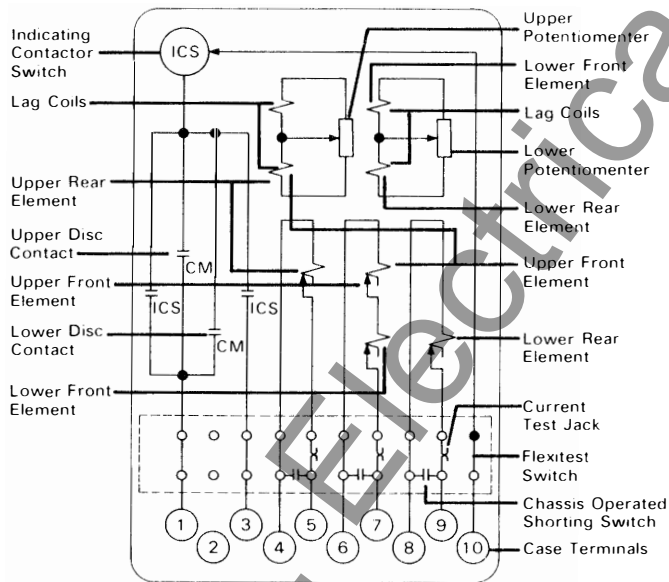

Figure 7 762A812



ABB Power T&D Company Inc.  
Relay Division  
Coral Springs, FL  
Allentown, PA

Descriptive Bulletin  
41-161E

Page 5

December, 1990  
Supersedes TD 41-020, Type CM on  
page 14, dated November, 1987  
Mailed to: E, D, C/41-100A

For Phase Current Unbalance  
Protection of Polyphase Apparatus  
From Phase Unbalance or Phase Failure  
Tapped Type

## Type CM Phase Balance Current Relay

### Type Balance, Three Phase (Device Number: 46)

Type	Contacts	Indicating Contactor Switch <sup>②</sup>	Taps	Continuous Current Rating	Relay Data		
					Internal Schematic	Relay Style No.	Case Size
CM <sup>①</sup>	Spst-cc	0.2/2.0 amp dc	1, 2, or 3 amps	7	762A812	290B960A21 <sup>③</sup>	FT-31

<sup>③</sup> Denotes item available from stock.

<sup>①</sup> 50 Hertz relays and auxiliaries can be supplied at same price. Order "Similar to Style Number . . . . ., except 50 Hertz".

<sup>②</sup> ICS: Indicating Contactor Switch (dc current operated) having seal-in contacts and indicating target which are actuated when the ICS coil is energized at or above pickup current setting. Suitable for dc control voltages up to and including 250 volts dc. Two current ranges available:

- (1) 0.2/2.0 amps dc, with tapped coil.
- (2) 1.0 amp dc, without taps.

Rating of ICS unit used in specific types of relays is shown in price tables. All other ratings must be negotiated.

When ac current is necessary in a control trip circuit, the ICS unit can be replaced by an ACS unit.

The ACS unit may be supplied in place of an ICS unit at no additional cost. Specify system voltage rating on order.