



**Instruction Book  
2 of 2**

**M-3311A Transformer  
Protection Relay**

**BECKWITH**  **CO. INC.  
ELECTRIC**

# Transformer Protection M-3311A

Integrated Protection System®

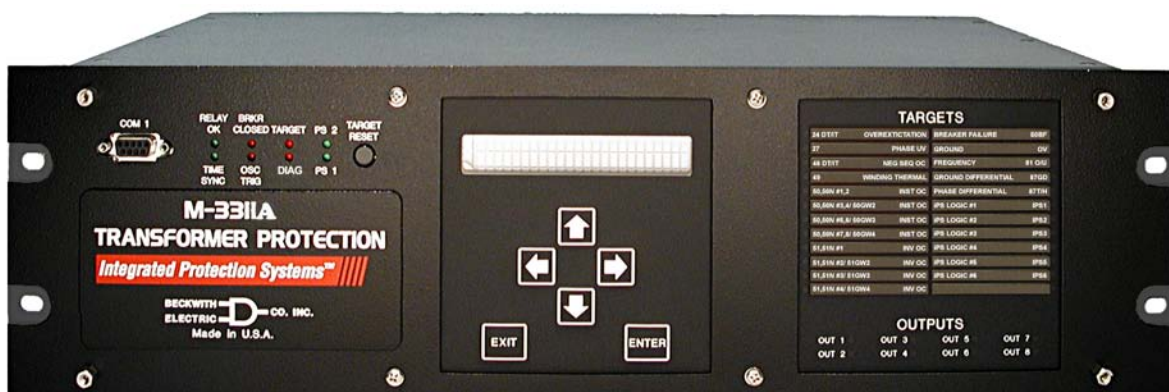

Unit shown with optional M-3931 HMI Module and M-3911 Target Module

- **For Transformers of All Sizes:**
  - ◆ **2, 3 or 4 winding Transformers for Transmission and Distribution applications**
  - ◆ **Generator-Transformer Unit Overall Differential**
  - ◆ **Unit Protection of Other Electrical Apparatus and certain Bus Arrangements (including those with a transformer in the zone)**
- **Additional Applications: System Backup Protection, Load Shedding (voltage and frequency), Bus Protection, and individual Breaker Failure Protection for each winding input**
- **Options: Ethernet Connection and Expanded I/O**

## Standard Protective Functions

- Negative-sequence inverse time overcurrent (46)
- Winding thermal protection (49)
- Four winding instantaneous phase overcurrent (50)
- Breaker Failure (50BF)
- Instantaneous ground overcurrent (50G)
- Instantaneous residual overcurrent (50N)
- Four winding inverse time phase overcurrent (51)
- Inverse time ground overcurrent (51G)
- Inverse time residual overcurrent (51N)
- Two, three or four winding phase differential (87T) and high set instantaneous (87H)
- Ground differential (87GD)
- IPSlogic™

## Optional Single-Phase Voltage Protection Package

- Overexcitation (24) V/Hz, two definite time and one inverse time elements
- Phase undervoltage (27) function for load shedding
- Ground Overvoltage (59G)
- Over/Underfrequency (81O/U)

## Standard Features

- Eight programmable outputs and six programmable inputs
- Oscillographic recording
- Through-Fault Monitoring
- 10-target storage
- Real time metering of measured and calculated parameters, including demand currents
- Two RS-232 and one RS-485 communications ports
- Standard 19" rack-mount design
- Removable printed circuit board and power supply
- 50 and 60 Hz models available
- 1 or 5 A rated CT inputs available
- M-3826 IPScom® Communications Software
- IRIG-B time synchronization
- Sequence of Events Log
- Breaker Monitoring
- Multiple Setpoint Groups
- Trip Circuit Monitoring
- Includes MODBUS and DNP 3.0 protocols
- Summing Currents from multiple sources for 49, 50, 51, 50N, 51N, 87 GD and Through Fault functions

## Optional Features

- Redundant Power Supply
- M-3911A Target Module
- M-3931 Human-Machine Interface (HMI) Module
- M-3801D IPSplot® Plus Oscillograph Analysis Software
- RJ45 Ethernet port utilizing MODBUS over TCP/IP
- Expanded I/O (8 additional outputs and 12 additional inputs)

**STANDARD PROTECTIVE FUNCTIONS**

<b>Device Number</b>	<b>Function</b>	<b>Setpoint Ranges</b>	<b>Increment</b>	<b>Accuracy<sup>†</sup></b>
<b>Negative Sequence Overcurrent</b>				
<b>46</b>	<b>46W2/46W3/46W4</b>			
	<b>Definite Time Pickup</b>	0.10 to 20.00 A (0.02 to 4.00 A)	0.01 A	±0.1 A or ±3% (±0.02 A or ±3%)
	<b>Time Delay</b>	1 to 8160 Cycles	1 Cycle	-1 to +3 Cycles or ±1%
	<b>Inverse Time Pickup</b>	0.50 to 5.00 A (0.10 to 1.00 A)	0.01 A	±0.1 A or ±3% (±0.02 A or ±3%)
	<b>Characteristic Curves Time Dial Setting</b>	Definite Time/Inverse/Very Inverse/Extremely Inverse/IEC Curves 0.5 to 11.0 0.05 to 1.10 (IEC curves) 0.85 to 1.15 (IEEE curves)	0.1 0.01 0.01	±3 Cycles or ±5%
	<b>Winding Thermal Protection</b>			
<b>49</b>	<b>Time Constant</b>	1.0 to 999.9 minutes	0.1 minutes	
	<b>Maximum Overload Current</b>	1.00 to 10.00 A	0.01 A	±0.01 A
	<b>Winding Select</b>	Sum1, Sum2, W1, W2, W3, or W4		
<b>Instantaneous Phase Overcurrent</b>				
<b>50</b>	<b>1-8</b>			
	<b>Pickup</b>	1.0 to 100.0 A (0.2 to 20.0 A)	0.1 A	±0.1 A or ±3% (±0.02 A or ±3%)
	<b>Time Delay</b>	1 to 8160 Cycles	1 Cycle	±2 Cycles or ±1%
<b>Current Selection</b>	Sum1, Sum2, W1, W2, W3, W4			
<b>Breaker Failure</b>				
<b>50 BF</b>	<b>50BFW1/50BFW2/50BFW3/50BFW4</b>			
	<b>Pickup (phase)</b>	0.10 to 10.00 A (0.02 to 2.00 A)	0.01 A	±0.1 A or ±2% (±0.02 A or ±2%)
	<b>Pickup (residual)</b>	0.10 to 10.00 A (0.02 to 2.00 A)	0.01 A	±0.1 A or ±2% (±0.02 A or ±2%)
<b>Time Delay</b>	1 to 8160 Cycles	1 Cycle	-1 to +3 Cycles or ±2%	
<b>Instantaneous Ground Overcurrent</b>				
<b>50G</b>	<b>50GW2/50GW3/50GW4</b>			
	<b>Pickup #1, #2</b>	1.0 to 100.0 A (0.2 to 20.0 A)	0.1 A	±0.1 A or ±3% (±0.02 A or ±3%)
<b>Time Delay #1, #2</b>	1 to 8160 Cycles	1 Cycle	±2 Cycles or ±1%	

<sup>†</sup>Select the greater of these accuracy values.  
rating.

Values in parentheses apply to 1 A CT secondary

**STANDARD PROTECTIVE FUNCTIONS (cont.)**

<b>Device Number</b>	<b>Function</b>	<b>Setpoint Ranges</b>	<b>Increment</b>	<b>Accuracy†</b>
<b>Instantaneous Residual Overcurrent</b>				
<b>50N</b>	1-8 Pickup	1.0 to 100.0 A (0.2 to 20.0 A)	0.1 A	±0.1 A or ±3% (±0.02 A or ±3%)
	Time Delay	1 to 8160 Cycles	1 Cycle	±2 Cycles or ±1%
	Current Selection	Sum1, Sum2, W1, W2, W3, W4		
<b>Inverse Time Phase Overcurrent</b>				
<b>51</b>	1-4 Pickup	0.50 to 12.00 A (0.10 to 2.40 A)	0.01 A	±0.1 A or ±3% (±0.02 A or ±3%)
	Current Selection	Sum1, Sum2, W1, W2, W3, W4		
	Characteristic Curve	Beco Definite Time/Inverse/Very Inverse/Extremely Inverse IEC Inverse/Very Inverse/Extremely Inverse/Long Time Inverse IEEE Moderately Inverse/Very Inverse/Extremely Inverse		
	Time Dial Setting	0.5 to 11.0 0.05 to 1.10 (IEC curves) 0.85 to 1.15 (IEEE curves)	0.1 0.01 0.01	±3 Cycles or ±3%
<i>Two or three of the windings may be summed together.</i>				
<b>Inverse Time Ground Overcurrent</b>				
<b>51GW2/51GW3/51GW4</b>	Pickup	0.50 to 12.00 A (0.10 to 2.40 A)	0.01 A	±0.1 A or ±3% (±0.02 A or ±3%)
	Characteristic Curve	Beco Definite Time/Inverse/Very Inverse/Extremely Inverse IEC Inverse/Very Inverse/Extremely Inverse/Long Time Inverse IEEE Moderately Inverse/Very Inverse/Extremely Inverse		
	Time Dial Setting	0.5 to 11.0 0.05 to 1.10 (IEC curves) 0.85 to 1.15 (IEEE curves)	0.1 0.01 0.01	±3 Cycles or ±3%
<b>Inverse Time Residual Overcurrent</b>				
<b>51N</b>	1-4 Pickup	0.50 to 6.00 A (0.10 to 1.20 A)	0.01 A	±0.1 A or ±3% (±0.02 A or ±3%)
	Characteristic Curve	Beco Definite Time/Inverse/Very Inverse/Extremely Inverse IEC Inverse/Very Inverse/Extremely Inverse/Long Time Inverse IEEE Moderately Inverse/Very Inverse/Extremely Inverse		
	Time Dial Setting	0.5 to 11.0 0.05 to 1.10 (IEC curves) 0.85 to 1.15 (IEEE curves)	0.1 0.01 0.01	±3 Cycles or ±5%
	Current Selection	Sum1, Sum2, W1, W2, W3, W4		

†Select the greater of these accuracy values. Values in parentheses apply to 1 A CT secondary rating.

**STANDARD PROTECTIVE FUNCTIONS (cont.)**

Device Number	Function	Setpoint Ranges	Increment	Accuracy†
<b>Phase Differential Current</b>				
<b>87H</b>				
	Pickup	5.0 to 20.0 PU	0.1 PU	±0.1 PU or ±3%
	Time Delay	1 to 8160 Cycles	1 Cycle	-1 to +3 Cycles or ±1%
<b>87T</b>				
87	Pickup	0.10 to 1.00 PU	0.01 PU	±0.02 PU or ±5%
	Percent Slope #1	5 to 100%	1%	±1%
	Percent Slope #2	5 to 200%	1%	±1%
	Slope Break Point	1.0 to 4.0 PU	0.1 PU	—
	Even Harmonics Restraint (2nd and 4th)	5 to 50%	1%	±1% or ±0.1 A
	5th Harmonic Restraint	5 to 50%	1%	±1% or ±0.1 A
	Pickup at 5th Harmonic Restraint	0.10 to 2.00 PU	0.01 PU	±0.1 PU or ±5%
<b>CT Tap W1/W2/W3/W4</b>				
		1.00 to 100.00 (0.2 to 20)	0.01	—

*Trip response for 87T and 87H (if time delay set to 1 cycle) is less than 1.5 cycles. Each restraint element may be individually disabled, enabled, or set for cross phase averaging.*

**Ground Differential**

<b>87GDW2/87GDW3/87GDW4</b>				
87 GD	Pickup #1, #2	0.2 to 10.00 A (0.04 to 2.00 A)	0.01 A	±0.1 A or ±5% (±0.02 A or ±5%)
	Time Delay #1, #2	1 to 8160 Cycles*	1 Cycle	-1 to +3 Cycles or ±1%
	3I <sub>0</sub> Current Selection	Sum1, Sum2, W2		
	Directional Element	Disable/Enable		
	CT Ratio Correction (R <sub>c</sub> )	0.10 to 7.99	0.01	

*\*The Time Delay should not be less than 2 cycles.*

*This function is selectable as either directional or non-directional. If 3I<sub>0</sub> is extremely small, directional element is disabled.*

**IPSlogic**

IPS	IPSlogic uses element pickups, element trip commands, control/status input state changes, output contact close signals with programmable logic array to develop schemes.			
	Reset/Dropout Delay #1–#6	0 to 65500 Cycles	1 Cycle	±1 Cycle or ±1%
	Time Delay #1–#6	1 to 65500 Cycles	1 Cycle	±1 Cycle or ±1%

**Trip Circuit Monitoring**

TCM	Time Delay	1 to 8160 Cycles	1 Cycle	±1 Cycle or ±1%
-----	------------	------------------	---------	-----------------

*The AUX input is provided for monitoring the integrity of the trip circuit. This input can be used for nominal trip coil voltages of 24 V dc, 48 V dc, 125 V dc and 250 V dc.*

†Select the greater of these accuracy values. Values in parentheses apply to 1 A CT secondary rating.

**STANDARD PROTECTIVE FUNCTIONS (cont.)**

Device Number	Function	Setpoint Ranges	Increment	Accuracy <sup>†</sup>
<b>Breaker Monitoring</b>				
BM	Pickup	1 to 50,000 kA Cycles or kA <sup>2</sup> Cycles	1 kA Cycles or kA <sup>2</sup> Cycles	± 1 kACycles or kA <sup>2</sup> Cycles
	Time Delay	0.1 to 4095.9 Cycles	0.1 Cycles	±1 Cycle or ±1%
	Timing Method	IT or I <sup>2</sup> T		
	Preset Accumulators Phase A, B, C	0 to 50,000 kA Cycles	1 kA Cycle	

The Breaker Monitor feature calculates an estimate of the per-phase wear on the breaker contacts by measuring and integrating the current (or current squared) through the breaker contacts as an arc.

The per-phase values are added to an accumulated total for each phase, and then compared to a user-programmed threshold value. When the threshold is exceeded in any phase, the relay can set a programmable output contact.

The accumulated value for each phase can be displayed.

The Breaker Monitoring feature requires an initiating contact to begin accumulation, and the accumulation begins after the set time delay.

<b>Through Fault</b>				
TF	Through Fault Current Threshold	1.0 to 100.0 (A)	0.1A	±0.1A or ±5% (±0.02A or ±5%)
	Through Fault Count Limit	1 to 65535	1	—
	Cumulative I <sup>2</sup> T Limit	1 to 1000000(kA <sup>2</sup> Cycles)	1	±1.0 kA Cycles or kA <sup>2</sup> Cycles
	Time Delay	1 to 8160 Cycles	1Cycle	±1 Cycle or ±1%
	Current Selection	Sum1, Sum2, W1, W2, W3 or W4	—	—

<b>Nominal Settings</b>				
Nominal Voltage	60.0 to 140.0 V	0.1 V	—	
VT Configuration	V <sub>A'</sub> , V <sub>B'</sub> , V <sub>C'</sub> , V <sub>AB'</sub> , V <sub>BC'</sub> , V <sub>CA'</sub> , V <sub>G</sub>			
Phase Rotation	ABC/ACB	—	—	
Number of Windings	2, 3, or 4			
Transformer/CT Connection	Standard IEEE/IEC or Custom Connections			

### Functions that can be Implemented with Overcurrent/Input-Output Connections

#### Load Shedding

Can help prevent overloading of remaining transformers when a station transformer is out of service.

#### Bus Fault Protection

Provides high speed bus protection by combining digital feeder relay logic and transformer protection logic.

#### Feeder Digital Relay Backup

Provides backup tripping of feeder relays by combining the self test alarm output of the feeder relays with the transformer relay.

#### LTC fault blocking

Provides limited blocking of LTC during fault conditions.

<sup>†</sup>Select the greater of these accuracy values.  
rating.

Values in parentheses apply to 1 A CT secondary rating.

**OPTIONAL SINGLE-PHASE VOLTAGE PROTECTION PACKAGE**

Device Number	Function	Setpoint Ranges	Increment	Accuracy†
<b>Volts/Hz Overexcitation</b>				
<b>Definite Time</b>				
	Pickup #1, #2	100 to 200%	1%	± 1%
	Time Delay #1, #2	30 to 8160 Cycles	1 Cycle	+25 Cycles
<b>Inverse Time</b>				
24	Pickup	100 to 150%	1%	± 1%
	Characteristic Curves	Inverse Time #1–#4	—	—
	Time Dial: Curve #1	1 to 100	1	—
	Time Dial: Curves #2–#4	0.0 to 9.0	0.1	—
	Reset Rate	1 to 999 Sec. (from threshold of trip)	1 Sec.	±.06 Seconds or ±1%

Pickup based on nominal VT secondary voltage and nominal system frequency. Accuracy applicable from 10 to 80 Hz, 0 to 180 V, and 100 to 150% V/Hz.

This function is applicable only when phase voltage input is applied.

<b>Phase Undervoltage</b>				
27	Pickup	5 to 140 V	1 V	±0.5 V
	Inhibit Setting	5 to 140 V	1 V	±0.5 V
	Time Delay	1 to 8160 Cycles	1 Cycle	-1 to +3 Cycles or ±1%

This function is applicable only when phase voltage input is applied.

<b>Ground Overvoltage</b>				
59G	Pickup #1, #2	5 to 180 V	1 V	±0.5 V or ±0.5%
	Time Delay #1, #2	1 to 8160 Cycles	1 Cycle	±1 Cycle or ±1%

This function is applicable only when voltage input from a broken delta VT is applied.

<b>Overfrequency/Underfrequency</b>				
81 O/U	Pickup #1, #2, #3, #4	55.00 to 65.00 Hz 45.00 to 55.00 Hz*	0.01 Hz	±0.1 Hz
	Time Delay #1, #2, #3, #4	2 to 65,500** Cycles	1 Cycle	-1 to +3 Cycles or ±1%

Accuracy applies to 60 Hz models at a range of 57 to 63 Hz, and to 50 Hz models at a range of 47 to 53 Hz.

\* This range applies to 50 Hz nominal frequency models.

\*\* For 65,500 cycles, time delay setting phase voltage must be greater than 35 V ac.

This function is applicable only when phase voltage of at least 27 V ac input is applied.

## Configuration Options

The M-3311A Transformer Protection Relay may be purchased as a fully configured two, three or four winding Transformer Protection System. The M-3311A can also be purchased with the Optional Single-Phase Voltage Protection Package to expand the system to satisfy specific application needs.

## Multiple Setpoint Profiles (Groups)

The relay supports four setpoint profiles. This feature allows multiple setpoint profiles to be defined for different power system configurations. Profiles can be switched either manually using the Human-Machine Interface (HMI), communication, or by control/status inputs.

## Metering

Metering of voltage, three-phase and neutral currents, and frequency. Phase voltage and current metering include sequence components.

Real Time Demand (interval of 15, 30 or 60 minutes), and Maximum Demand (with date and time stamp) metering of current.

Metering accuracies are:

Voltage:  $\pm 0.5$  V or  $\pm 0.5\%$ , whichever is greater (range 0 to 180 V ac)

Current: 5 A rating,  $\pm 0.1$  A or  $\pm 3\%$ , whichever is greater (range 0 to 14 A)  
1 A rating,  $\pm 0.02$  A or  $\pm 3\%$ , whichever is greater (range 0 to 2.8 A)

Frequency:  $\pm 0.1$  Hz (from 57 to 63 Hz for 60 Hz models; from 47 to 53 Hz for 50 Hz models)

## Oscillographic Recorder

The oscillographic recorder provides comprehensive data recording of all monitored waveforms for Windings 1, 2, 3 and 4. The total record length is user-configurable up to 24 partitions. The amount of data stored depends on the winding configuration and number of partitions. For example; 2 windings and 1 partition configuration can store up to 311 cycles, 3 windings and 1 partition configuration can store up to 231 cycles and 4 windings and 1 partition configuration can store up to 183 cycles.

The sampling rate is 16 times the power system nominal frequency (50 or 60 Hz). The recorder is triggered by a designated status input, trip output, or using serial communications. When untriggered, the recorder continuously stores waveform data, thereby keeping the most recent data in memory. When triggered, the recorder stores pre-trigger data, then continues to store data in memory for a user-defined, post-trigger delay period. The records may be analyzed using Beckwith Electric IPSPlot® Plus Oscillograph Analysis Software, and are also available in COMTRADE file format.

## Sequence of Events Log

The Sequence Events Log records predefined relay events. The Sequence of Events Log includes 512 of the most recently recorded relay events. The events and the associated data is available for viewing utilizing the M-3826 IPScom Communications Software.

## Through Fault Recorder

In addition to the Even Recorder, the M-3311A also has a separate Through Fault Recorder, which records Through Faults. Each through fault record contains the serial number of the fault, duration of the event, maximum RMS fault current magnitude for each phase during the fault,  $I^2t$  and the time stamp of the fault. In addition, it will also store the total number of through faults since last reset and total  $I^2t$  for each phase since last reset (up to 256 records).

## Target Storage

A total of 8 targets can be stored. This information includes the function(s) operated, the function(s) picked up, input/output contact status, time stamp, phase and ground currents.

## Calculations

**Current and Voltage Values:** Uses discrete Fourier Transform (DFT) algorithm on sampled voltage and current signals to extract fundamental frequency phasors for M-3311A calculations.

## Power Input Options

Nominal 110/120/230/240 V ac, 50/60 Hz, or nominal 110/125/220/250 V dc. Operates properly from 85 V ac to 265 V ac and from 80 V dc to 312.5 V dc. Withstands 300 V ac or 315 V dc for 1 second. Nominal burden 20 VA at 120 V ac/125 V dc.

Nominal 24/48 V dc, operates properly from 18 V dc to 56 V dc, withstands 65 V dc for 1 second. Burden 25 VA at 24 V dc and 30 VA at 48 V dc.

An optional redundant power supply is available for units that are purchased without the I/O Expansion Module.

For those units purchased with the I/O Expansion Module the unit includes two power supplies which are required.

## Sensing Inputs

*Two Voltage Inputs:* Rated nominal voltage of 60 V ac to 140 V ac, 50/60 Hz. Withstands 240 V continuous voltage and 360 V for 10 seconds. Voltage input may be connected to phase voltage (L-G or L-L), or to a broken delta VT. Voltage transformer burden less than 0.2 VA at 120 V.

*15 Current Inputs:* Rated current ( $I_R$ ) of 5.0 A or 1.0 A (optional), 50/60 Hz. Withstands 3  $I_R$  continuous current and 100  $I_R$  for 1 second. Current transformer burden is less than 0.5 VA at 5 A (5 A option), or 0.3 VA at 1 A (1 A option).

## Control/Status Inputs

The control/status inputs, INPUT1 through INPUT6, can be programmed to block any of the relay functions, trigger the oscillographic recorder, select a setpoint group, or to operate one or more outputs. The control/status inputs are designed to be connected to dry contacts and are internally wetted, with a 24 V dc power supply. To provide breaker status LED indication on the front panel, the INPUT1 status input contact must be connected to the 52b breaker status contact.

The optional Expanded I/O includes an additional 12 programmable control/status inputs.

## Output Contacts

Any of the functions can be individually programmed to activate any one or more of the eight programmable output contacts OUTPUT1 through OUTPUT8. Any output contact can also be selected as pulsed or latched. IPSlogic can also be used to activate an output contact.

The optional I/O Expansion Module includes an additional 8 programmable output contacts.

The eight output contacts (six form 'a' and two form 'c'), the power supply alarm output contact (form 'b'), the self-test alarm output contact (form 'c') and the optional 8 I/O Expansion Module output contacts (form 'a') are all rated per ANSI/IEEE C37.90-1989 for tripping. Make 30 A for 0.2 seconds, carry 8 A, break 6 A at 120 V ac, break 0.5 A at 48 V dc; 0.3 A, 125 V dc; 0.2 A, 250 V dc with L/R=40 mSec.

## Breaker Monitoring

The Breaker Monitoring function calculates an estimate of the per-phase wear on the breaker contacts by measuring and integrating the current (selected as  $I^2t$  or  $I_t$ ) passing through the breaker contacts during the interruption interval. The per-phase values are summed as an accumulated total for each phase, and then compared to a user-programmed threshold value. When the threshold is exceeded in any phase, the relay can activate a programmable output contact. The accumulated value for each phase can be displayed as an actual value.

## IPSlogic

This feature can be programmed utilizing the IPScm® Communications Software. IPSlogic takes the contact input status and function status, and by employing (OR, AND, and NOT) boolean logic and a timer can activate an output or change setting profiles.

## Target/Status Indicators and Controls

The **RELAY OK** LED reveals proper cycling of the microcomputer. The **BRKR CLOSED** LED illuminates when the breaker is closed (when the 52b contact is open). The **OSC TRIG** LED indicates that oscillographic data has been recorded in the unit's memory. The corresponding **TARGET** LED will illuminate when any of the relay functions trip. Pressing and releasing the **TARGET RESET** button resets the **TARGET** LEDs if the conditions causing the operation have been removed. Pressing and holding the **TARGET RESET** button will allow elements or functions in pickup to be displayed. The **PS1** and **PS2** LEDs remain illuminated as long as power is applied to the unit and the power supply is operating properly. **TIME SYNCH** LED illuminates when valid IRIG-B signal is applied and time synchronization has been established.

## Communication

Communication ports include rear RS-232 and RS-485 ports, a front RS-232 port, and a rear IRIG-B port (Ethernet port optional). The communications protocol implements serial, byte-oriented, asynchronous communication, providing the following functions when used with the Windows™-compatible M-3826 IPScm® Communications Software.

- Interrogation and modification of setpoints
- Time-stamped trip target information for the 32 most recent events
- Real-time metering of all measured and calculated quantities, real-time monitoring of percentage differential characteristics, and vector displays of compensated and uncompensated phasors.
- Downloading of recorded oscillographic data
- Downloading of Through-Fault Event Log
- MODBUS and DNP 3.0 protocols are supported

Detailed documentation on the above protocols is available on the Beckwith Electric website, at [www.beckwithelectric.com](http://www.beckwithelectric.com)

## IRIG-B

The M-3311A accepts either modulated or demodulated IRIG-B time clock synchronization signals. The IRIG-B time synchronization information is used to correct the local calendar/clock and provide greater resolution for target and oscillograph time tagging.

## HMI Module (optional)

Local access to the M-3311A is provided through an optional M-3931 Human-Machine Interface (HMI) Module, allowing for easy-to-use, menu-driven access to all functions via a 6-button keyboard and a 2-line by 24 character alphanumeric display. The M-3931 module includes the following features:

- User-definable access codes providing three levels of security
- Interrogation and modification of setpoints
- Time-stamped trip target information for the 8 most recent events
- Real-time metering of all measured and calculated quantities

## I/O Expansion Module (optional)

An optional I/O Expansion Module provides an additional 8 form 'a' output contacts and an additional 12 control/status inputs. Output LEDs indicate the status of the output relays.

## Target Module (optional)

An optional M-3911A Target Module provides 24 target and 8 output LEDs. Appropriate target LEDs illuminate when the corresponding M-3311A function trips. The targets can be reset with the M-3311A **TARGET RESET** button if the trip conditions have been removed. The **OUTPUT** LEDs illuminate when a given programmable output is actuated.

## M-3801D IPSPlot® Plus Oscillograph Analysis Software (optional)

M-3801D IPSPlot Plus Oscillograph Analysis Software enables the plotting and printing of M-3311A waveform data downloaded from the relay to any IBM-PC compatible computer.

## Tests and Standards

The relay complies with the following type tests and standards:

### Voltage Withstand

#### Dielectric Withstand

IEC 60255-5	3,500 V dc for 1 minute applied to each independent circuit to earth
	3,500 V dc for 1 minute applied between each independent circuit
	1,500 V dc for 1 minute applied to IRIG-B circuit to earth
	1,500 V dc for 1 minute applied between IRIG-B to each independent circuit
	1,500 V dc for 1 minute applied between RS-485 to each independent circuit

#### Impulse Voltage

IEC 60255-5	5,000 V pk, +/- polarity applied to each independent circuit to earth
	5,000 V pk, +/- polarity applied between each independent circuit
	1.2 by 50 $\mu$ s, 500 ohms impedance, three surges at 1 every 5 seconds

#### Insulation Resistance

IEC 60255-5	> 100 Megaohms
-------------	----------------

## Electrical Environment

### Electrostatic Discharge Test

IEC 60255-22-2	Class 4 (8 kV)—point contact discharge
IEC 60255-22-2	Class 4 (15 kV)—air discharge

### Fast Transient Disturbance Test

IEC 60255-22-4	Class A (4 kV, 2.5 kHz)
----------------	-------------------------

### Surge Withstand Capability

ANSI/IEEE	2,500 V pk-pk oscillatory applied to each independent circuit to earth
C37.90.1-	2,500 V pk-pk oscillatory applied between each independent circuit
1989	5,000 V pk Fast Transient applied to each independent circuit to earth
	5,000 V pk Fast Transient applied between each independent circuit
ANSI/IEEE	2,500 V pk-pk oscillatory applied to each independent circuit to earth
C37.90.1-	2,500 V pk-pk oscillatory applied between each independent circuit
2002	4,000 V pk Fast Transient burst applied to each independent circuit to earth
	4,000 V pk Fast Transient burst applied between each independent circuit

■ **NOTE:** The signal is applied to the digital data circuits (RS-232, RS-485, IRIG-B, Ethernet communication port and field ground coupling port) through capacitive coupling clamp.

## M-3311A Transformer Protection Relay

### ***Radiated Susceptibility***

ANSI/IEEE 25-1000 Mhz @ 35 V/m  
C37.90.2

### ***Output Contacts***

ANSI/IEEE Make 30 A for 0.2 seconds, off for 15 seconds for 2,000 operations, per Section 6.7.1,  
C37.90.0 Tripping Output Performance Requirements

## **Atmospheric Environment**

### ***Temperature***

IEC 60068-2-1 Cold, -20° C  
IEC 60068-2-2 Dry Heat, +70° C  
IEC 60068-2-3 Damp Heat, +40° C @ 93% RH

## **Mechanical Environment**

### ***Vibration***

IEC 60255-21-1 Vibration response Class 1, 0.5 g  
Vibration endurance Class 1, 1.0 g

IEC 60255-21-2 Shock Response Class 1, 0.5 g  
Shock Withstand Class 1, 15.0 g  
Bump Endurance Class 1, 10.0g

## **Compliance**

cULus-Listed per 508 – Industrial Control Equipment  
– Industrial Control Equipment Certified for Canada CAN/USA C22.2 No. 14-M91  
cULus-Listed per 508A – Table SA1.1 Industrial Control Panels

## **External Connections**

M-3311A external connections points are illustrated in Figure 1 and 2.

## **Physical**

### ***Without Optional I/O Expansion Module***

**Size:** 19.00" wide x 5.21" high x 10.20" deep (48.3 cm x 13.2 cm x 25.9 cm)

**Mounting:** The unit is a standard 19", semiflush, three-unit high, rack-mount panel design, conforming to ANSI/EIA RS-310C and DIN 41494 Part 5 specifications. Vertical or horizontal panel-mount options are available.

**Approximate Weight:** 16 lbs (7 kg)

**Approximate Shipping Weight:** 25 lbs (11.3 kg)

### ***With Optional I/O Expansion Module***

**Size:** 19.00" wide x 6.96" high x 10.2" deep (48.3 cm x 17.7 cm x 25.9 cm)

**Mounting:** The unit is a standard 19", semiflush, four-unit high, rack-mount panel design, conforming to ANSI/EIA RS-310C and DIN 41494 Part 5 specifications. Vertical or horizontal panel-mount options are available.

**Approximate Weight:** 19 lbs (8.6 kg)

**Approximate Shipping Weight:** 26 lbs (11.8 kg)

## **Recommended Storage Parameters**

**Temperature:** 5° C to 40° C

**Humidity:** Maximum relative humidity 80% for temperatures up to 31° C, decreasing to 31° C linearly to 50% relative humidity at 40° C.

**Environment:** Storage area to be free of dust, corrosive gases, flammable materials, dew, percolating water, rain and solar radiation.

*See M-3311A Instruction Book, Appendix E, Layup and Storage for additional information.*

## **Patent & Warranty**

The M-3311A Generator Protection Relay is covered by U.S. Patents 5,592,393 and 5,224,011.

The M-3311A Generator Protection Relay is covered by a five-year warranty from date of shipment.

*Specification subject to change without notice.*

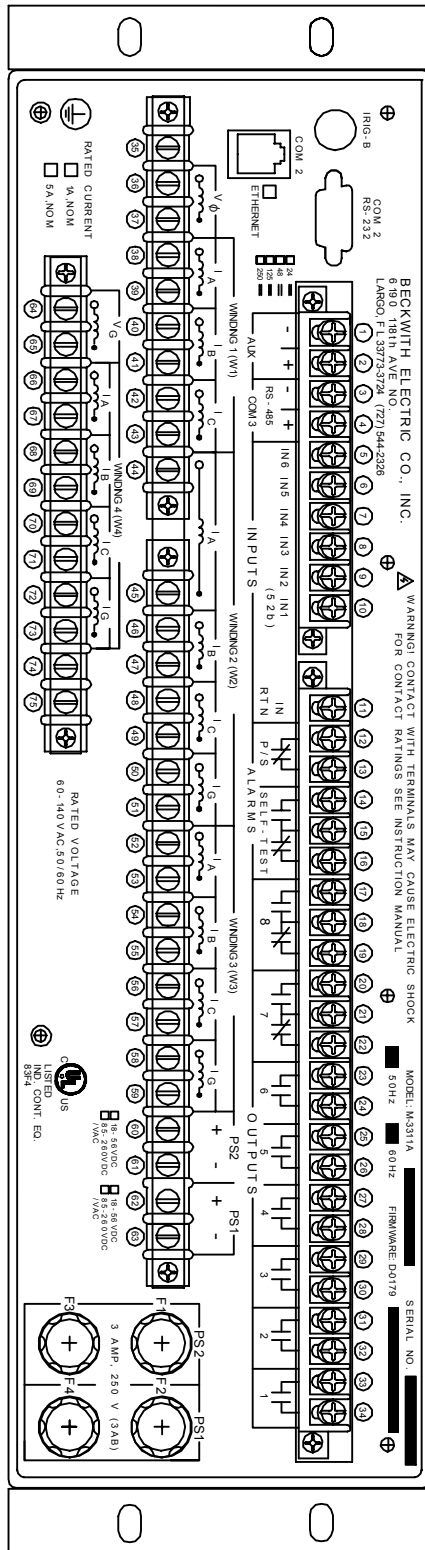

Figure 1 External Connections

NOTES:

1. Output contacts #1 through #4 contain special circuitry for high-speed operation, and close 4 ms faster than outputs 5 through 8. Outputs 1 through 6 are form "a" contacts (normally open) and outputs 7 and 8 are form "c" contacts (center tapped 'a' and 'b' contacts).
2. To comply with UL and CSA listing requirements, terminal block connections must be made with #12 AWG solid or stranded copper wire inserted in an AMP #324915 (or equivalent) connector. Wire insulation must be rated at 60° C minimum. Terminal block connections 1 through 34 must be tightened to 12 inch-pounds torque. Terminal block connections 35 through 63 must be tightened to 8 inch-pounds torque.
3. Only dry contacts must be connected to inputs (terminals 5 through 10 with 11 common) because these contact sensing inputs are internally wetted. **Application of external voltage on these inputs may result in damage to the unit.**
4. All relays are shown in the de-energized state, and without power applied to the relay
5. The power supply relay (P/S) is energized when the power supply is functioning properly.
6. The self-test relay is energized when the relay has performed all self-tests successfully.

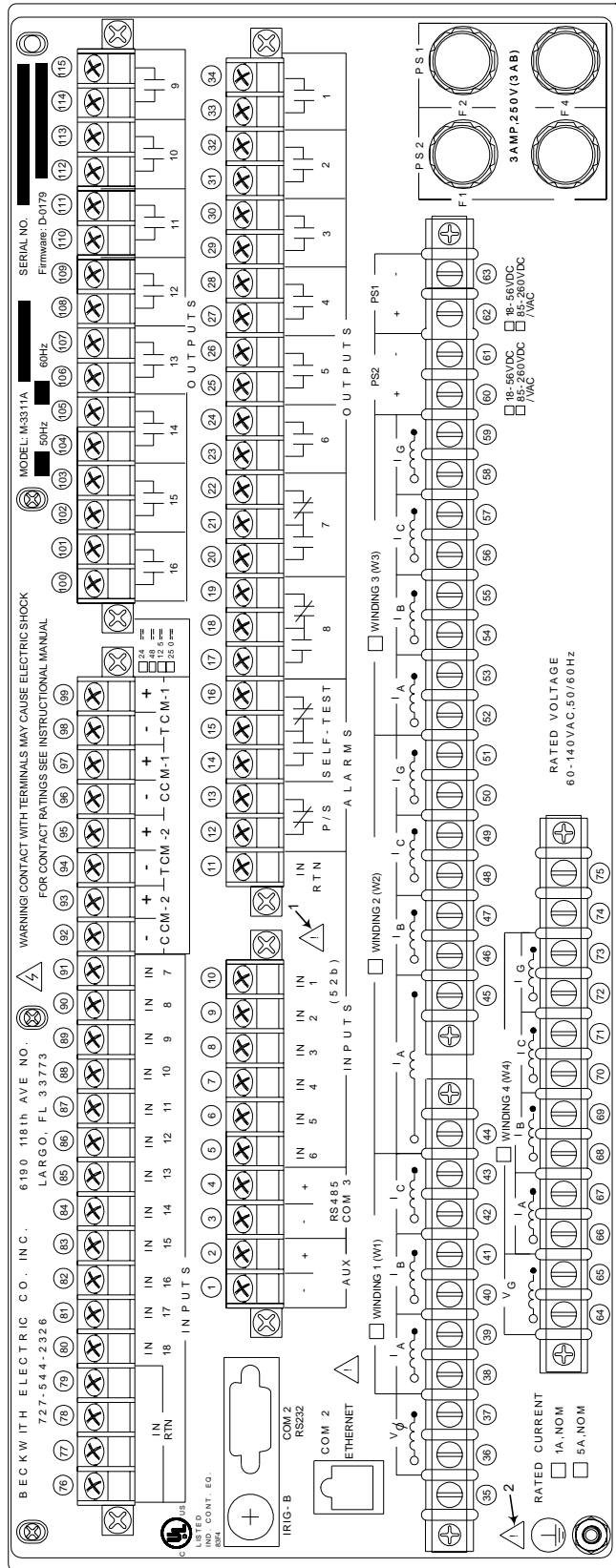

Figure 2 External Connections (With Optocon Expanded I/O)

NOTES:

1. **WARNING: ONLY DRY CONTACTS** must be connected to inputs (terminals 5 through 10 with 11 common and terminals 68 through 75 with 66 and 67 common) because these contact inputs are internally wetted. Application of external voltage on these inputs may result in damage to the units.
2. **WARNING:** The protective grounding terminal must be connected to an earthed ground any time external connections have been made to the unit.

# M-3311A Transformer Protection Relay

## M-3311A Typical Connection Diagram Four Winding Model

- This function is available as a standard protective function.
- This function is available in the Optional Single-Phase Voltage Protection Package.

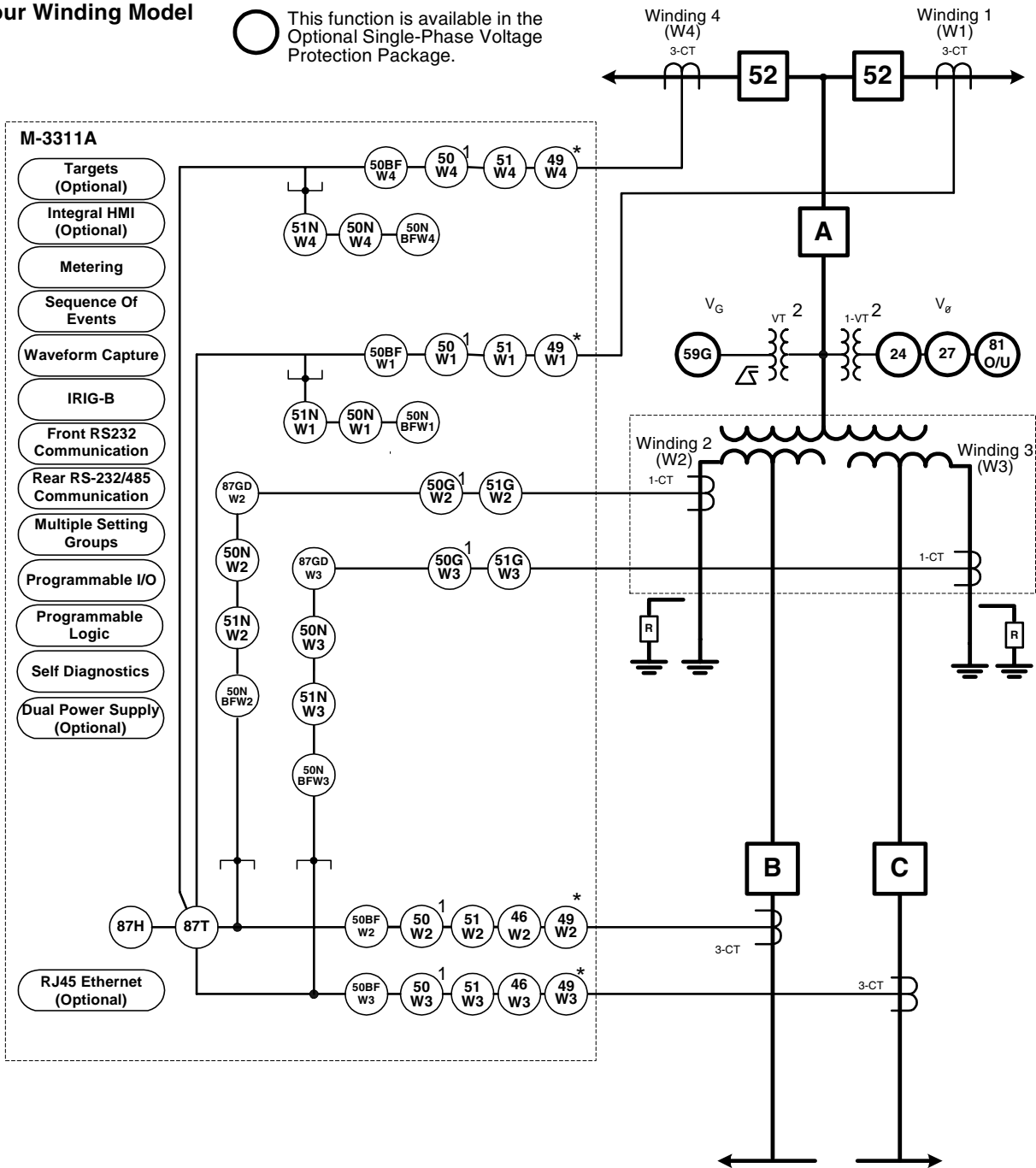



\* 49 Function can only be enabled in one winding.

### NOTES:

1. All 50 and 50G functions may be applied instantaneous or definite time, and are multiple (2) elements, each with individual pickup and time delay setpoints.
2. Two voltage inputs are available in the 4-winding model of the M-3311A. These are a phase voltage  $V_{\phi}$  use for the 81O/U, 27, and 24 Functions and the  $V_G$  broken delta input voltage used for the 59G function. These voltage inputs are not winding dependent.

Figure 3 M-3311A Typical One-Line Function Diagram

**M-3311A Typical Connection Diagram Four Winding Model**

-  This function is available as a standard protective function.
-  This function is available in the Optional Single-Phase Voltage Protection Package.

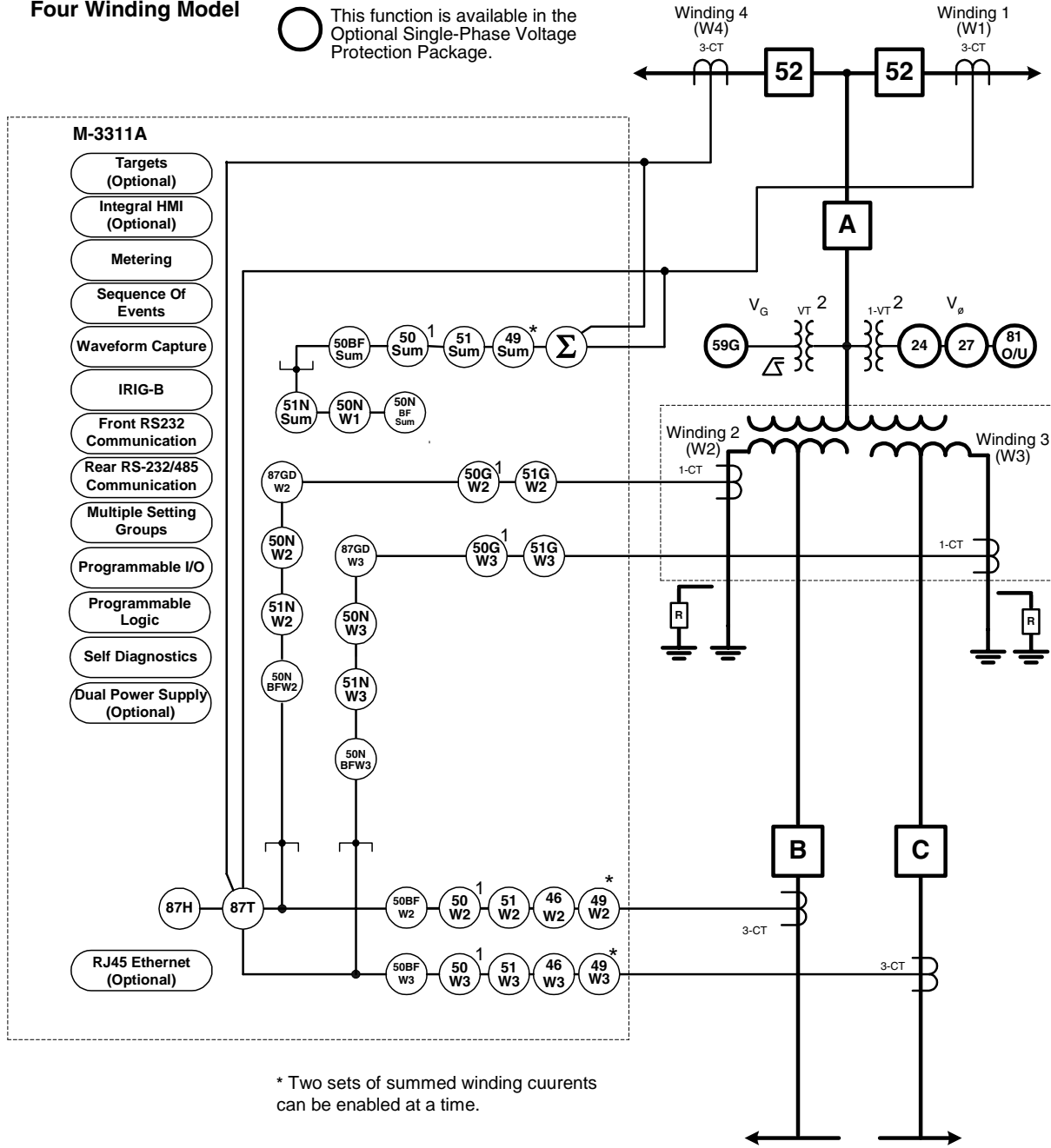

\* 49 Function can only be enabled in one winding.

**NOTES:**

1. All 50 and 50G functions may be applied instantaneous or definite time, and are multiple (2) elements, each with individual pickup and time delay setpoints.
2. Two voltage inputs are available in the 4-winding model of the M-3311A. These are a phase voltage  $V_{\phi}$  use for the 81O/U, 27, and 24 Functions and the  $V_G$  broken delta input voltage used for the 59G function. These voltage inputs are not winding dependent.

Figure 4 Typical M-3311A Summing Currents One Line Functional Diagram



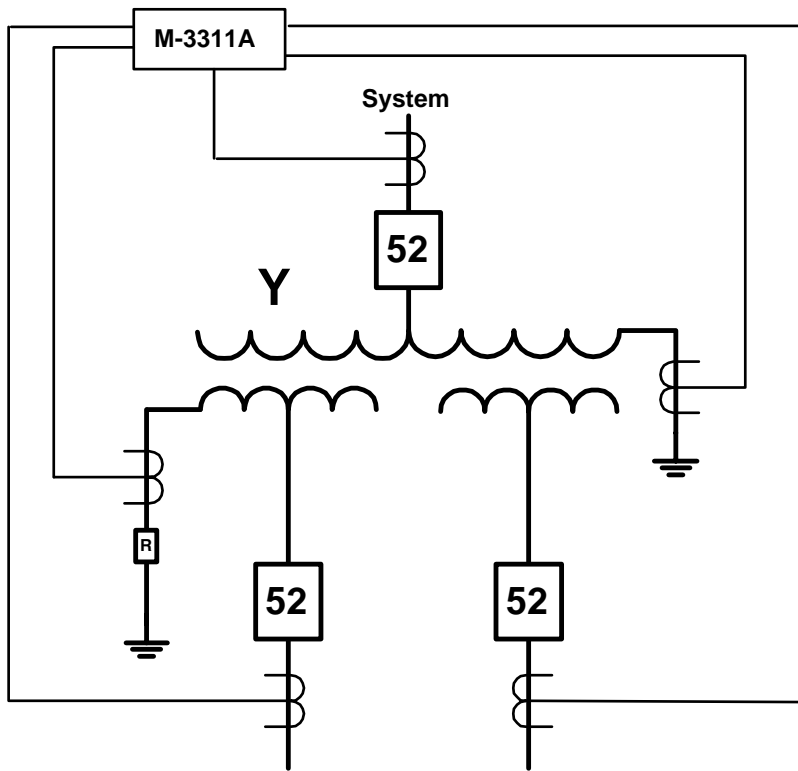

Figure 7 Three Winding Transformer with High Impedance Ground

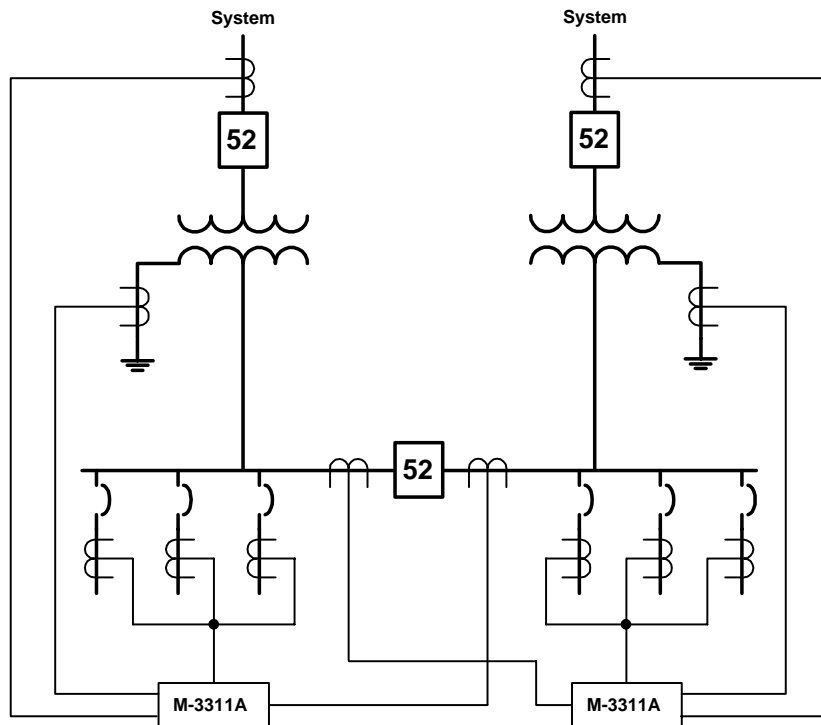
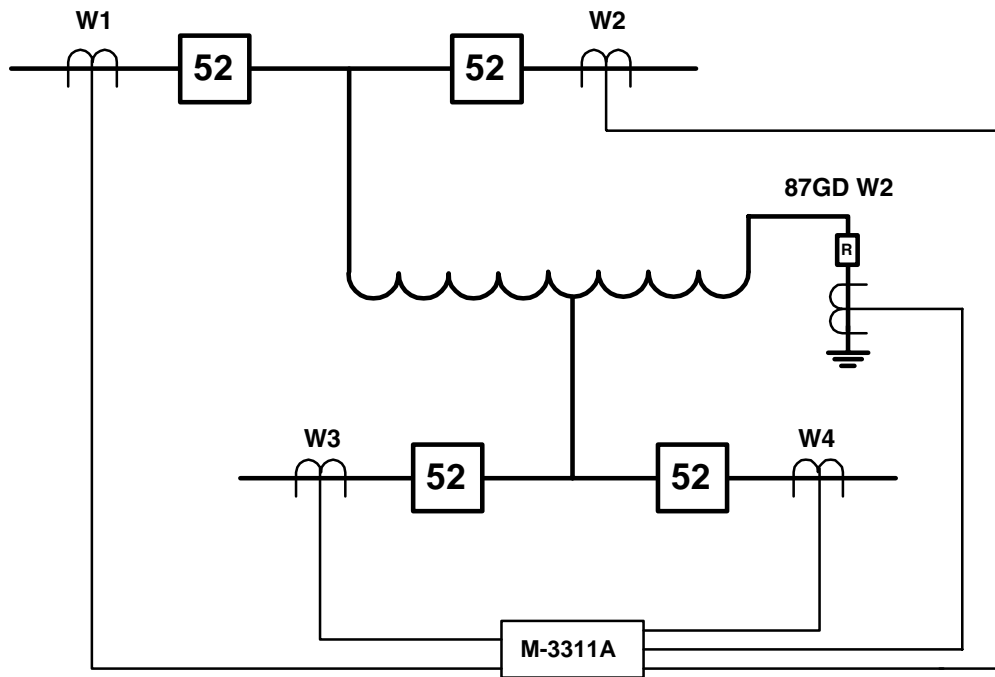

Figure 8 Dual Bank Distribution Substation

M-3311A Transformer Protection Relay



■ NOTES:

1. Winding 1 & 2 current summed and Winding 3 & 4 current summed for overcurrent function
2. 87GDW2 function  $3I_0$  current is the sum of W1, W2, W3 and W4 currents.

Figure 9 Auto Transformer with two Circuit Breakers on High and Low Side

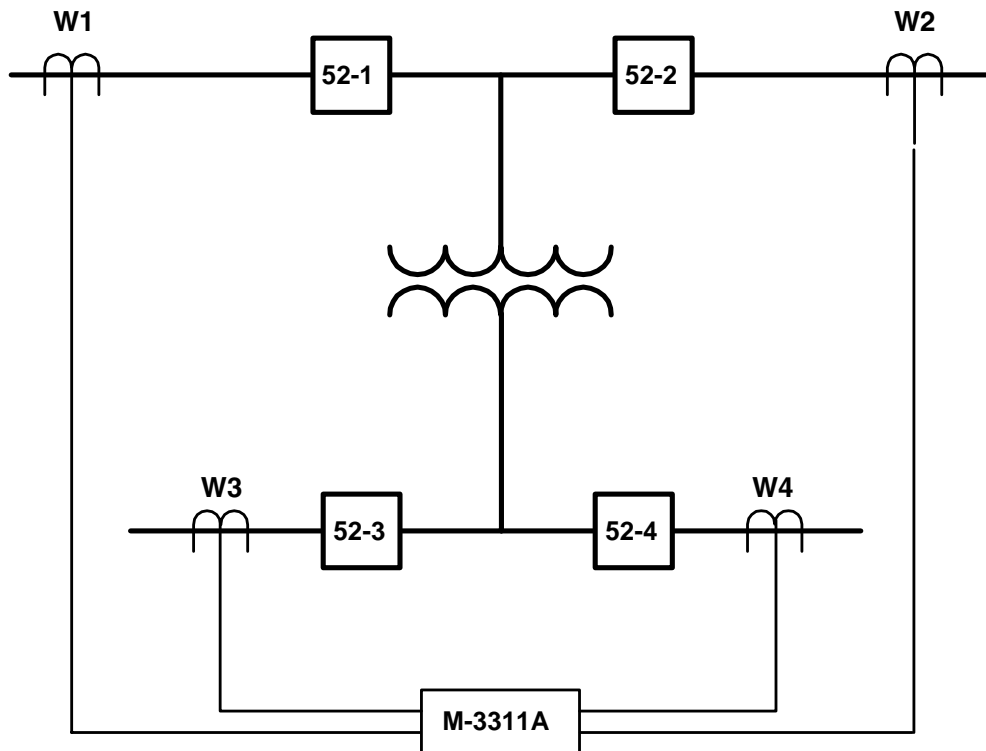

Figure 10 Two Winding Transformer with Two Circuit Breakers on High and Low Sides

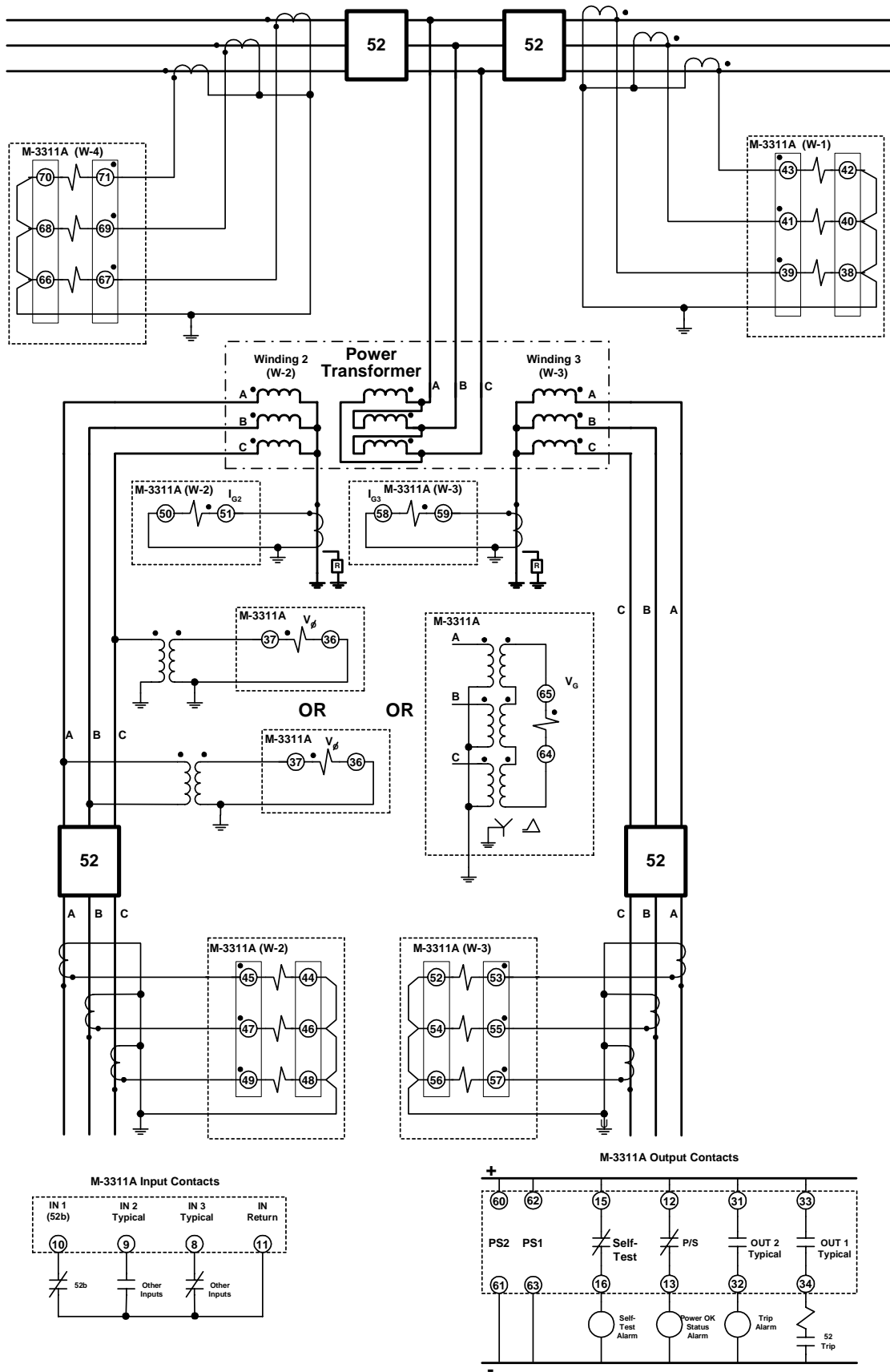
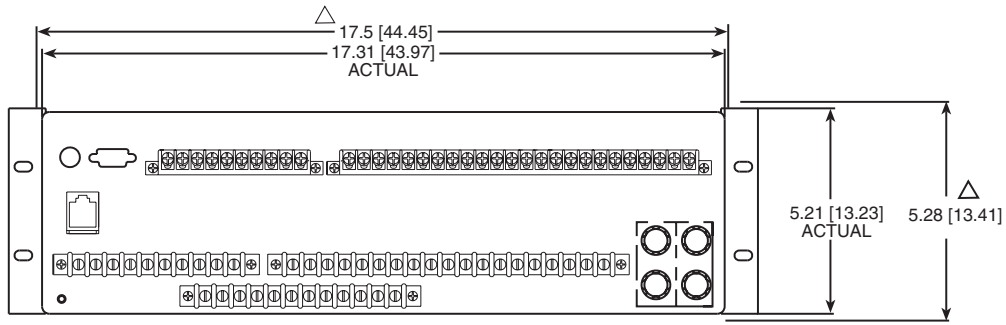

Figure 11 Typical Three-Line Connection Diagram

# M-3311A Transformer Protection Relay



Rear View

△ RECOMMENDED CUTOUT WHEN RELAY IS NOT USED AS STANDARD RACK MOUNT AND IS PANEL CUT OUT MOUNTED

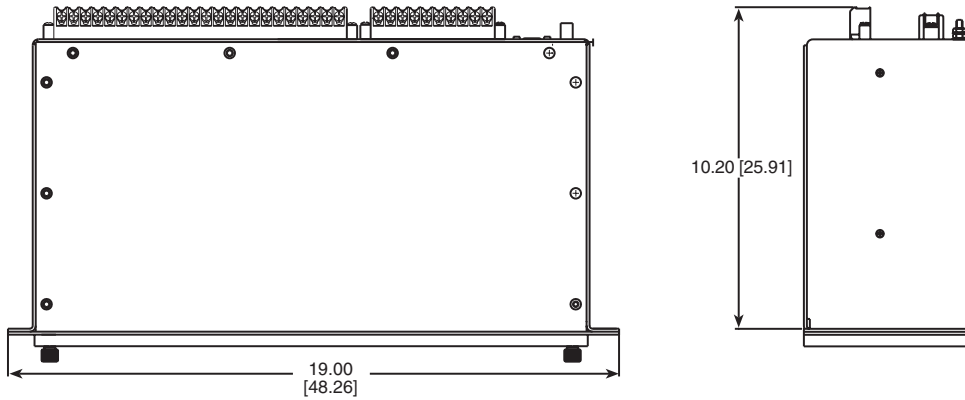

Top View

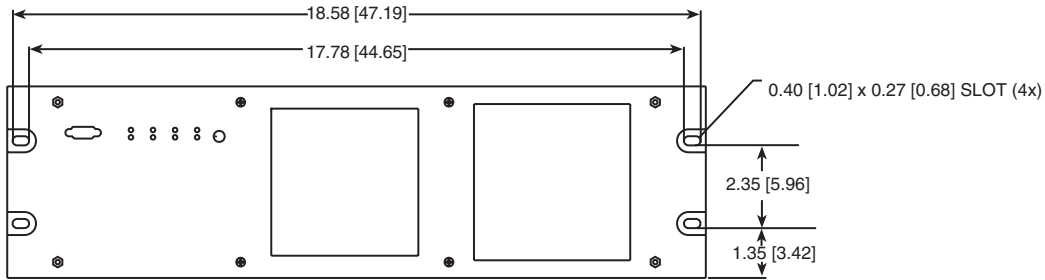

Front View

## Standard 19" Horizontal Mount Chassis

■ **NOTE:** Dimensions in brackets are in centimeters.

Figure 12 Horizontal Mounting Dimensions

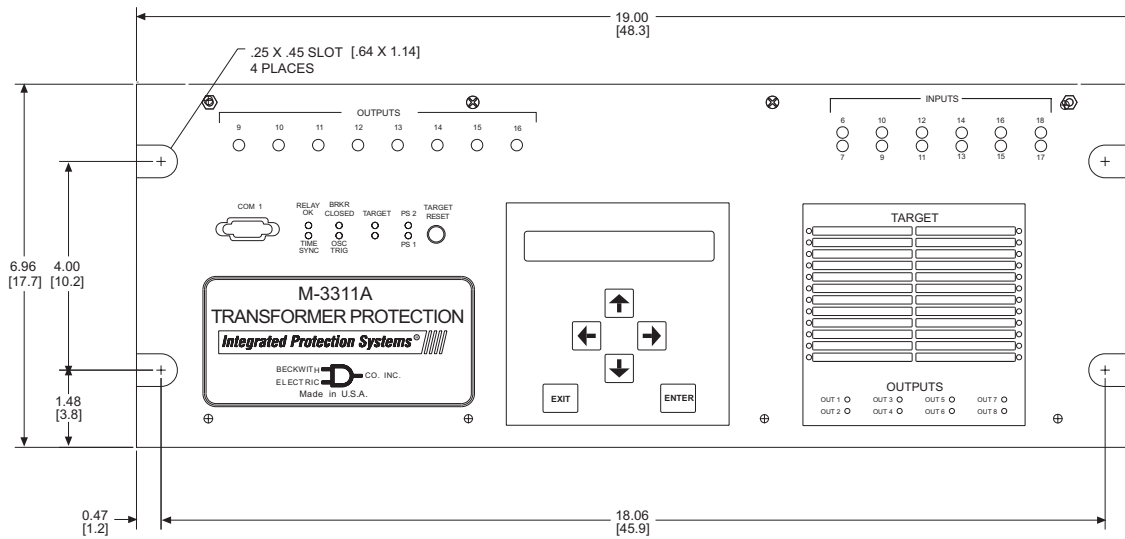
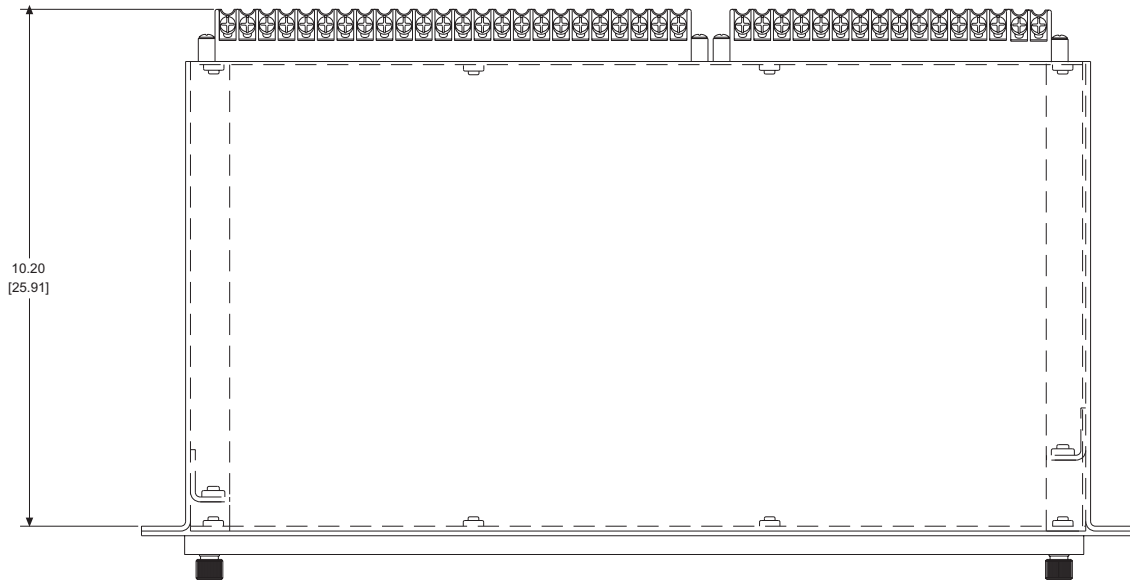
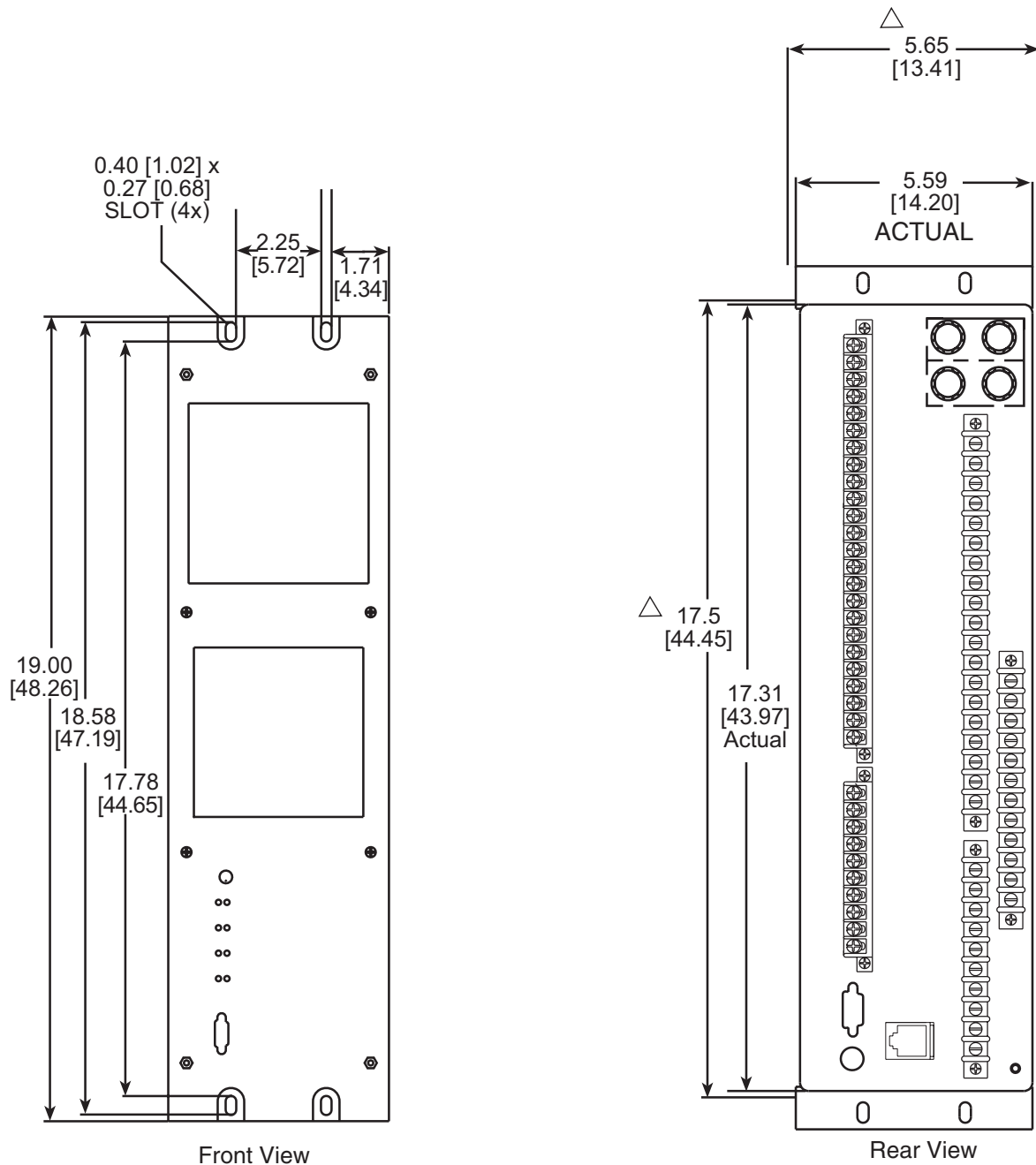

Figure 13 Horizontal Mounting Dimensions (With Expanded I/O)



■ **NOTE:** Dimensions in brackets are in centimeters.

△ RECOMMENDED CUTOUT WHEN RELAY IS NOT USED AS STANDARD RACK MOUNT AND IS PANEL CUT OUT MOUNTED

### Optional Vertical Mount Chassis

Figure 14 Vertical Mounting Dimensions

M-3311A Transformer Protection Relay

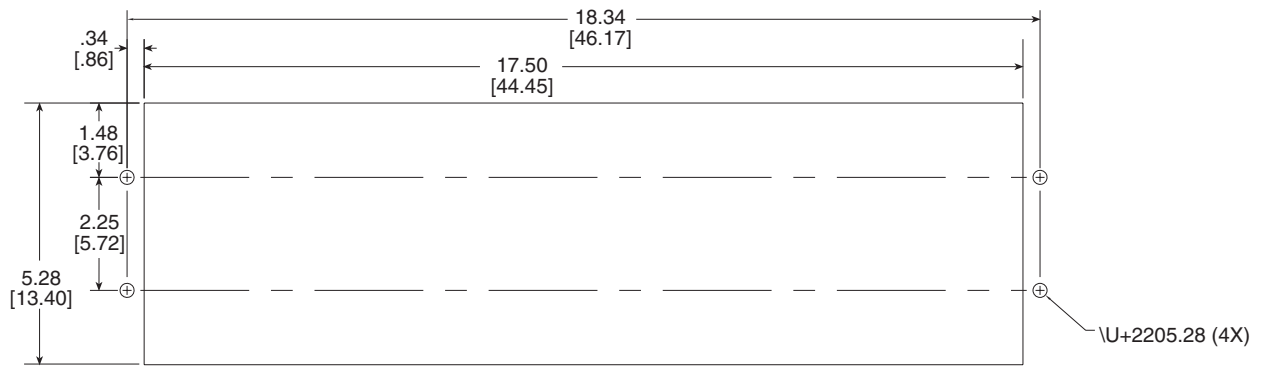

RECOMMENDED CUTOUT  
STANDARD 3 UNIT PANEL M-3311A

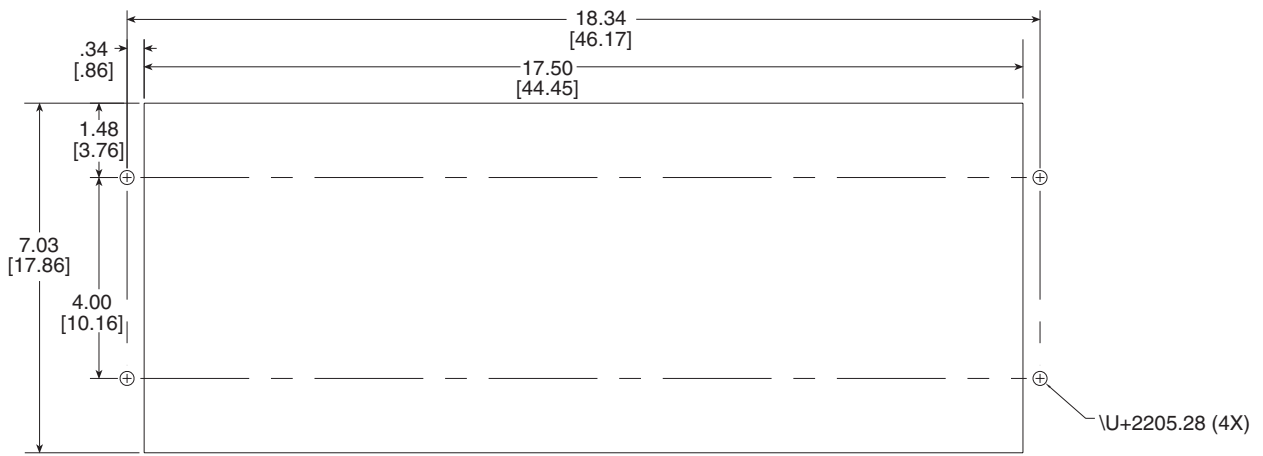

RECOMMENDED CUTOUT  
4 UNIT PANEL M-3311A (EXTENDED I/O)

TOLERANCE: .XX±.015

Figure 15 M3311A Panel Mount Cutout Dimensions



**BECKWITH ELECTRIC CO., INC.**

6190 - 118th Avenue North • Largo, Florida 33773-3724 U.S.A.

PHONE (727) 544-2326 • FAX (727) 546-0121

E-MAIL [marketing@beckwithelectric.com](mailto:marketing@beckwithelectric.com)

WEBPAGE [www.beckwithelectric.com](http://www.beckwithelectric.com)

# WARNING

**DANGEROUS VOLTAGES**, capable of causing death or serious injury, are present on the external terminals and inside the equipment. Use extreme caution and follow all safety rules when handling, testing or adjusting the equipment. However, these internal voltage levels are no greater than the voltages applied to the external terminals.

## **DANGER! HIGH VOLTAGE**



- This sign warns that the area is connected to a dangerous high voltage, and you must never touch it.

## **PERSONNEL SAFETY PRECAUTIONS**

*The following general rules and other specific warnings throughout the manual must be followed during application, test or repair of this equipment. Failure to do so will violate standards for safety in the design, manufacture, and intended use of the product. Qualified personnel should be the only ones who operate and maintain this equipment. Beckwith Electric Co., Inc. assumes no liability for the customer's failure to comply with these requirements.*



- This sign means that you should refer to the corresponding section of the operation manual for important information before proceeding.



### **Always Ground the Equipment**

To avoid possible shock hazard, the chassis must be connected to an electrical ground. When servicing equipment in a test area, the Protective Earth Terminal must be attached to a separate ground securely by use of a tool, since it is not grounded by external connectors.

### **Do NOT operate in an explosive environment**

Do not operate this equipment in the presence of flammable or explosive gases or fumes. To do so would risk a possible fire or explosion.

### **Keep away from live circuits**

Operating personnel must not remove the cover or expose the printed circuit board while power is applied. In no case may components be replaced with power applied. In some instances, dangerous voltages may exist even when power is disconnected. To avoid electrical shock, always disconnect power and discharge circuits before working on the unit.

### **Exercise care during installation, operation, & maintenance procedures**

The equipment described in this manual contains voltages high enough to cause serious injury or death. Only qualified personnel should install, operate, test, and maintain this equipment. Be sure that all personnel safety procedures are carefully followed. Exercise due care when operating or servicing alone.

### **Do not modify equipment**

Do not perform any unauthorized modifications on this instrument. Return of the unit to a Beckwith Electric repair facility is preferred. If authorized modifications are to be attempted, be sure to follow replacement procedures carefully to assure that safety features are maintained.

## **PRODUCT CAUTIONS**

*Before attempting any test, calibration, or maintenance procedure, personnel must be completely familiar with the particular circuitry of this unit, and have an adequate understanding of field effect devices. If a component is found to be defective, always follow replacement procedures carefully to that assure safety features are maintained. Always replace components with those of equal or better quality as shown in the Parts List of the Instruction Book.*

### **Avoid static charge**

This unit contains MOS circuitry, which can be damaged by improper test or rework procedures. Care should be taken to avoid static charge on work surfaces and service personnel.

### **Use caution when measuring resistances**

Any attempt to measure resistances between points on the printed circuit board, unless otherwise noted in the Instruction Book, is likely to cause damage to the unit.

# TABLE OF CONTENTS

## M-3311A Transformer Protection

### Instruction Book

Chapters Book 1 of 2	Page
<b>Specification</b>	
<b>Chapter 1 Introduction</b>	
1.1 Instruction Book Contents .....	1-1
Chapter 1: Introduction .....	1-1
Chapter 2: Operation .....	1-1
Chapter 3: IPScom .....	1-1
Chapter 4: System Setup and Setpoints .....	1-1
Chapter 5: Installation .....	1-1
Chapter 6: Testing .....	1-1
Appendix A: Configuration Record Forms .....	1-1
Appendix B: Communications .....	1-1
Appendix C: Self-Test Error Codes .....	1-2
Appendix D: Inverse Time Curves .....	1-2
Appendix E: Layup and Storage .....	1-2
1.2 M-3311A Transformer Protection Relay .....	1-2
<b>Chapter 2 Operation</b>	
2.1 Operation .....	2-1
Alphanumeric Display .....	2-2
Screen Blanking .....	2-2
Arrow Pushbuttons .....	2-2
EXIT Pushbuttons .....	2-2
ENTER Pushbutton .....	2-2
RELAY OK LED .....	2-2
Time Sync LED .....	2-2
Breaker Closed (BRKR CLOSED) LED .....	2-2
Diagnostic LED (DIAG) .....	2-2
Power Supply (PS1) and (PS2) LEDs .....	2-3
Target LED .....	2-3
M-3911A Target Module and Target Reset Pushbutton .....	2-3
2.2 Operation (HMI/PC) .....	2-4
HMI Operation Overview .....	2-4
Default Message Screens .....	2-4
HMI Security .....	2-4
Status Monitoring (From Relay Front Panel) .....	2-6
Primary Metering and Status .....	2-7
Secondary Metering and Status .....	2-8
Metering II .....	2-9
View Targets .....	2-14
Oscillograph Recorder Data .....	2-15
User Access Codes .....	2-22
Through Fault Recorder (Through IPScom) .....	2-25

**Chapter 3 IPScom®**

3.1	IPScom Functional Description .....	3-1
	IPScom Main Screen Menu Bar .....	3-1
	Shortcut Command Buttons .....	3-1
	IPScom Main Screen Status Line .....	3-1
	File Menu .....	3-4
	Monitor/Primary Metering and Status .....	3-7
	Monitor/Secondary Metering and Status .....	3-8
	Monitor/Metering II .....	3-9
	Monitor/Phaser Diagram .....	3-10
	Monitor/Phaser Diagram (F87T) .....	3-11
	Monitor/Pickup/Timeout Status .....	3-12
	Relay Menu .....	3-13
	Relay Setup .....	3-13
	Relay/Setup/Configuration .....	3-13
	Relay/Setup/Relay Setpoints .....	3-14
	Relay/Setup/Extended I/O .....	3-15
	Relay/Setup/Setpoints/Display/I/O Map .....	3-16
	Relay/Setup/Display All Setpoints .....	3-17
	Relay/Demand Status .....	3-18
	Relay/Targets .....	3-19
	Relay/Through Fault .....	3-20
	Relay/Sequence of Events .....	3-21
	Relay/Oscillograph .....	3-23
	Relay/Profile .....	3-24
	Relay/Write File to Relay .....	3-25
	Relay/Read Data From Relay .....	3-25
	Tools Menu .....	3-25
	User Control Number .....	3-26
	Window Menu .....	3-28
	Help Menu .....	3-28

**Chapter 4 System Setup and Setpoints**

4.1	Unit Setup .....	4-1
	Comm Access Code .....	4-1
	IPScom Comm Access Code Setup .....	4-2
	HMI Comm Access Code Setup .....	4-2
	IPScom User Access Code Setup .....	4-3
	Setup User Access Codes .....	4-3
	HMI User Access Codes Setup .....	4-4
	User Logo Line .....	4-5
	User Control Number .....	4-5
	System OK Led .....	4-5
	IPScom User Logo Line, User Control Number and System OK Led Setup .....	4-5
	HMI User Logo Line Setup .....	4-5
	HMI User Control Number Setup .....	4-6
	HMI System OK LED Setup .....	4-7
	System Clock .....	4-8

**Chapter 4 System Setup and Setpoints (cont)**

	IPScorn Set Date/Time .....	4-8
	HMI Set Date and Time .....	4-8
	Communication Setup .....	4-10
	Ethernet Communication Settings .....	4-13
	DCHP Protocol .....	4-13
	Ethernet Protocols .....	4-13
	Installing the Modems .....	4-16
	Oscillograph Setup .....	4-18
4.2	System Setup .....	4-24
4.3	System Diagrams .....	4-30
4.4	System Setpoints .....	4-33
	24 Volts/Hz Overexcitation .....	4-34
	27 Phase Undervoltage .....	4-38
	46 Negative Sequence Overcurrent .....	4-39
	49 Winding Thermal Protection .....	4-41
	50BF Breaker Failure .....	4-44
	50/50G Instantaneous Overcurrent, Phase & Ground .....	4-46
	50N Instantaneous Residual Overcurrent .....	4-48
	51 Inverse Time Phase Overcurrent .....	4-49
	51 Inverse Time Residual Overcurrent .....	4-50
	51G Inverse Time Ground Overcurrent .....	4-51
	59 Ground Overvoltage .....	4-52
	81O/U Over/Underfrequency .....	4-53
	87 Phase Differential .....	4-55
	Coss Phase Averaging .....	4-57
	87GD Ground Differential .....	4-60
	Trip Circuit Monitoring .....	4-62
	Breaker Monitoring .....	4-63
	Through Fault .....	4-64
	IPLogic .....	4-65
4.5	System Applications and Logic Schemes .....	4-70
	Bus Fault Protection .....	4-70
	Backup for Digital Feeder Relay Failure .....	4-71
	Load Shedding .....	4-72
	LTC Blocking During Faults .....	4-74
4.6	Transformer Connections .....	4-75
	Transformer Winding Selection .....	4-75
	Transformer and CT Configuration .....	4-75
	Standard Transformer and CT Configuration .....	4-75
	Phase Angle Shift - Standard Connections .....	4-75
	Phase Angle Shift - Custom Connections .....	4-77
	Calculation of Differential & Restraint Currents .....	4-79
	M-3311A Connection Examples .....	4-79
	Auxiliary Transformer Example .....	4-79
	GSU Transformer Example .....	4-79

**Chapter 5 Installation**

5.1	General Information .....	5-1
5.2	Mechanical/Physical Dimensions .....	5-1
5.3	External Connections .....	5-6
5.4	Commissioning Checkout .....	5-10
5.5	Circuit Board Switches and Jumpers .....	5-11
5.6	IPScom Communications Software Installation .....	5-14
5.7	Activating Initial Local Communications .....	5-14
5.8	Initial Setup Procedure .....	5-15

**Chapter 6 Testing**

6.1	Equipment and Test Setup .....	6-2
6.2	Diagnostic Test Procedures .....	6-3
	Output Test (Relay) .....	6-3
	Input Test (Status) .....	6-4
	Status LED Test .....	6-5
	Target LED Test .....	6-5
	Button Test .....	6-6
	Display Test .....	6-6
	Communication Tests .....	6-6
	COM1 and COM2 Test .....	6-6
	COM3 Test (2-wire) .....	6-7
	Clock Test .....	6-8
	Flash Relay OK LED .....	6-8
	Factory Use Only .....	6-8
6.3	Automatic Calibration .....	6-9
6.4	Input Configurations .....	6-10
6.5	Functional Test Procedures .....	6-12
	Power On Self Tests .....	6-13
	24DT Volts/Hz Overexcitation Definite Time (#1 or #2) .....	6-14
	24IT Volts/Hz Overexcitation Inverse Time .....	6-15
	27 Phase Undervoltage .....	6-16
	46DT Negative Sequence Overcurrent Definite Time .....	6-17
	46IT Negative Sequence Overcurrent Inverse Time .....	6-18
	49 Winding Thermal Protection .....	6-19
	50 Instantaneous Phase Overcurrent Winding 1-8 .....	6-21
	50G Instantaneous Ground Overcurrent .....	6-22
	50N Instantaneous Residual Overcurrent .....	6-23
	50BF Breaker Failure .....	6-24
	51 Inverse Time Phase Overcurrent .....	6-26
	51G Inverse Time Ground Overcurrent .....	6-28
	51N Inverse Time Residual Overcurrent .....	6-29
	59G Ground Overvoltage (#1 or #2) .....	6-31
	81 Overfrequency/Underfrequency .....	6-32

**Chapter 6 Testing (cont)**

87H Phase Differential Overcurrent .....	6-33
87T Phase Differential Overcurrent .....	6-34
87GD Ground Differential (#1, #2) .....	6-37
BM Breaker Monitoring .....	6-38
Trip Circuit Monitoring .....	6-40
Through Fault .....	6-41
IPSlogic (#1-6) .....	6-42

**Appendices**

Appendix A: Forms .....	A-1
Appendix B: Communications .....	B-1
Appendix C: Error Codes .....	C-1
Appendix D: Inverse Time Curves .....	D-1
Appendix E: Layup and Storage .....	E-1

**Chapter 1 Introduction**

1-1 M-3911A Target Module ..... 1-4  
 1-2 M-3931 Human-Machine Interface (HMI) Module ..... 1-4

**Chapter 2 Operation**

2-1 M-3311A Front Panel ..... 2-3  
 2-2 Screen Message Menu Flow ..... 2-4  
 2-3 Main HMI Menu Flow ..... 2-5  
 2-4 Primary Metering and Status Screen ..... 2-7  
 2-5 Secondary Metering and Status Screen ..... 2-8  
 2-6 Metering II Screen ..... 2-9  
 2-7 Demand Status Screen ..... 2-12  
 2-8 View Targets Screen ..... 2-14  
 2-9 Clear Targets Confirmation Dialog Screen ..... 2-14  
 2-10 Clear Targets Dialog Screen ..... 2-15  
 2-11 Retrieve Oscillograph Record Dialog Screen ..... 2-17  
 2-12 Oscillograph Record Download Dialog Screen ..... 2-17  
 2-13 Oscillograph Download Successful Confirmation Screen ..... 2-17  
 2-14 Trigger Oscillograph Confirmation Screen ..... 2-18  
 2-15 Oscillograph Successfully Triggered Dialog Screen ..... 2-18  
 2-16 Clear Oscillograph Records Confirmation Screen ..... 2-18  
 2-17 Oscillograph Successfully Triggered Dialog Screen ..... 2-18  
 2-18 Change Comm Access Code Dialog Screen ..... 2-21  
 2-19 Comm Access Code Change Confirmation Screen ..... 2-21  
 2-20 Access Code Changed Confirmation Screen ..... 2-21  
 2-21 Change User Access Code Dialog Screen ..... 2-22  
 2-22 Counters and Error Codes Dialog Screen ..... 2-24  
 2-23 View Through Fault Record Screen ..... 2-25  
 2-24 Clear Through Fault Record Confirmation Screen ..... 2-26  
 2-25 Through Fault Record Cleared Successfully Screen ..... 2-26  
 2-26 Sequence of Events Retrieve/Download Screen ..... 2-26  
 2-27 Sequence of Events View Screen ..... 2-27  
 2-28 Clear Sequence of Events Record Command Confirmation Screen .... 2-27  
 2-29 Sequence of Events Record Cleared Confirmation Screen ..... 2-27

**Chapter 3 IPScom™**

3-1	IPScom Program Icon .....	3-1
3-2	IPScom Main Screen.....	3-2
3-3	M-3826 IPScom Menu Selection .....	3-3
3-4	New System Dialog Screen .....	3-4
3-5	IPScom Serial Communication Dialog Screen .....	3-5
3-6	IPScom TCP/IP Ethernet Communication Dialog Screen .....	3-5
3-7	IPScom Modem Communication Dialog Screen .....	3-6
3-8	Terminal Window .....	3-6
3-9	Primary Metering Status Screen .....	3-7
3-10	Secondary Metering Status Screen .....	3-8
3-11	Metering II Screen .....	3-9
3-12	Phasor Diagram .....	3-10
3-13	Phasor Diagram (F87T).....	3-11
3-14	Pickup/Timeout Status .....	3-12
3-15	87T Function Dual Slope Display .....	3-12
3-16	M-3826 IPScom Configuration Dialog Screen .....	3-13
3-17	Relay Setpoints Dialog Screen .....	3-14
3-18	Example Function Dialog Screen.....	3-14
3-19	Expanded I/O Enable/Disable Screen .....	3-15
3-20	Date/Time Dialog Screen .....	3-15
3-21	I/O Map Screen .....	3-16
3-22	Display All Setpoints Screen .....	3-17
3-23	Demand Status Dialog Screen .....	3-19
3-24	View Targets Dialog Screen .....	3-19
3-25	View Through Fault Record Screen .....	3-20
3-26	Sequence of Events Recorder Setup Screen .....	3-21
3-27	Sequence of Events Recorder Retrieve Screen .....	3-21
3-28	Sequence of Events Recorder View Screen .....	3-22
3-29	Setup Oscillograph Recorder Dialog Screen .....	3-23
3-30	Oscillograph Recorder Retrieve Dialog Screen .....	3-23
3-31	Profile Switching Method Dialog Screen .....	3-24
3-32	Select Profile Dialog Screen .....	3-24
3-33	Copy Active Profile Dialog Screen .....	3-24

**Chapter 3 IPScom™ (cont)**

3-34	Change Comm Access Code Dialog Screen .....	3-25
3-35	Change User Access Code Dialog Screen .....	3-25
3-36	User Information Screen .....	3-26
3-37	Change Relay Communication Address Dialog Screen .....	3-26
3-38	Setup Relay Comm Port Dialog Screen .....	3-26
3-39	Setup Relay Ethernet Port Dialog Screen .....	3-26
3-40	Output Test Dialog Screen .....	3-27
3-41	Counters and Error Codes Dialog Screen .....	3-27

**Chapter 4 System Setup and Setpoints**

4-1	Change Comm Access Code Dialog Screen .....	4-2
4-2	Comm Access Code Change Confirmation Screen .....	4-2
4-3	Access Code Changed Confirmation Screen .....	4-2
4-4	Change User Access Code Dialog Screen .....	4-3
4-5	User Information Dialog Screen .....	4-5
4-6	Setup Date/Time Dialog Screen .....	4-8
4-7	Setup Comm Port Dialog Screen .....	4-10
4-8	Setup Comm Port Dialog Screen .....	4-11
4-9	Setup Ethernet Screen .....	4-13
4-10	Modem Dialog Screen .....	4-16
4-11	Terminal Window .....	4-17
4-12	Setup Oscillograph Recorder .....	4-19
4-13	Setup Sequence of Events Recorder Dialog Screen .....	4-21
4-14	IPScom® Relay Configuration Dialog .....	4-29
4-15	Selection Screen for Expanded Input .....	4-29
4-16	A Typical One-Line Functional Diagram .....	4-30
4-17	M-3311A Typical Summing Currents One-Line Functional Diagram ....	4-31
4-18	Typical Three-Line Connection Diagram .....	4-32
4-19	Example of V/Hz Capability and Protection Curves .....	4-35
4-20	M-3826 IPScom® (24) Volts/Hertz Setpoint Ranges .....	4-37
4-21	M-3826 IPScom® (27) Undervoltage Setpoint Ranges .....	4-38
4-22	M-3826 IPScom® (46) Negative Sequence Overcurrent Setpoint Ranges .....	4-40

**Chapter 4 System Setup and Setpoints (cont)**

4-23 49 Function Overload Curves ..... 4-42

4-24 M-3826 IPScom® (49) Winding Thermal Protection Setpoint Ranges .... 4-43

4-25 Breaker Failure Logic Diagram ..... 4-44

4-26 M-3826 IPScom® (50BF) Breaker Failure Setpoint Ranges ..... 4-45

4-27 M-3826 IPScom®(50) Instantaneous Phase Overcurrent  
Setpoint Ranges ..... 4-47

4-28 M-3826 IPScom® (50G) Instantaneous Ground Overcurrent  
Setpoint Ranges ..... 4-47

4-29 M-3826 IPScom®(50N) Instantaneous Residual Overcurrent  
Setpoint Ranges ..... 4-48

4-30 M-3826 IPScom® (51) Inverse Time Phase Overcurrent  
Setpoint Ranges ..... 4-49

4-31 M-3826 IPScom® (51N) Inverse Time Residual Overcurrent  
Setpoint Ranges ..... 4-50

4-32 M-3826 IPScom®(51G) Inverse Time Ground Overcurrent  
Setpoint Ranges ..... 4-51

4-33 M-3826 IPScom® (59G) Ground Overvoltage Setpoint Ranges ..... 4-52

4-34 IPScom® (81O/U) Over/Underfrequency Setpoint Ranges ..... 4-54

4-35 M-3826 IPScom®(87) Phase Differential Current Setpoint Ranges .... 4-55

4-36 Transformer CT Tap Setting Example ..... 4-57

4-37 87T Programmable Dual Slope Percentage Restraint Characteristic .... 4-58

4-38 M-3826 IPScom® (87GD) Ground Differential Current Setpoint Ranges .... 4-61

4-39 Trip Circuit Monitoring Input ..... 4-62

4-40 Trip Circuit Monitor (TC) Setpoint Ranges ..... 4-62

4-41 M-3826 IPScom® Breaker Monitor Setpoint Ranges ..... 4-63

4-42 M-3826 IPScom Through Fault Function Setpoint Ranges ..... 4-64

4-43 IPSlogic Function Setup ..... 4-66

4-44 M-3826 IPScom®(IPS) IPSlogic Functions Setpoint Ranges ..... 4-67

4-45 Select Initiating Functions Screen ..... 4-68

4-46 IPSlogic® Function Setup ..... 4-69

4-47 Bus Fault Protection Scheme ..... 4-70

4-48 Digital Feeder Relay Backup Scheme ..... 4-71

4-49 Feeder Backup Logic ..... 4-71

4-50 Two Bank Load Shedding Scheme ..... 4-72

4-51 Load Shedding Logic ..... 4-73

**Chapter 4 System Setup and Setpoints (cont)**

4-52	LTC Blocking Scheme During Faults .....	4-74
4-53	Typical Transformer Differential Application .....	4-80
4-54	Delta-ac/Wye/Wye CT Connection Diagram .....	4-81
4-55	Custom Settings for Delta-ac/Wye/Wye .....	4-82
4-56	Wye/Delta-ac/Delta-ac CT Connection Diagram .....	4-83
4-57	Custom Settings for Wye/Delta-ac/Delta-ac .....	4-84

**Chapter 5 Installation**

5-1 M-3311A Mounting Dimensions – Horizontal Chassis ..... 5-2

5-2 M-3311A Mounting Dimensions – Vertical Chassis ..... 5-3

5-3 (H2) Mounting Dimensions ..... 5-4

5-4 (H3) Mounting Dimensions for GE L-2 Cabinet ..... 5-5

5-5 Optional Dual Power Supply ..... 5-6

5-6 Expanded I/O Power Supply ..... 5-6

5-7 Four Winding External Connections ..... 5-7

5-8 M-3311A Four Winding Extended Output External Connections ..... 5-8

5-9 Three-Line Connection Diagram ..... 5-9

5-10 M-3311A Circuit Board ..... 5-13

5-11 IPScm Program Icon ..... 5-14

**Chapter 6 Testing**

6-1 Status LED Panel ..... 6-5

6-2 M-3911 Target Module ..... 6-5

6-3 M-3931 Human-Machine Interface Module ..... 6-6

6-4 COM1/COM2 Loopback Plug ..... 6-7

6-5 RS-485 2-Wire Testing ..... 6-7

6-6 Voltage Calibration Configuration ..... 6-9

6-7 Current Calibration Configuration ..... 6-9

6-8 Voltage Inputs, Configuration V1 ..... 6-10

6-9 Voltage Inputs, Configuration V2 ..... 6-10

6-10 Current Inputs, Configuration C1 ..... 6-10

6-11 Current Inputs, Configuration C2 ..... 6-10

6-12 Current Inputs, Configuration C3 ..... 6-10

6-13 Current Inputs, Configuration C4 ..... 6-10

6-14 Current Inputs, Configuration C5 ..... 6-10

6-15 Current Configuration C6 ..... 6-11

**Appendix A**

A-1	M-3931 Human-Machine Interface Module .....	A-4
A-2	Functional Configuration Record Form .....	A-5
A-3	Unit Setup and Communication Data Record Form .....	A-14
A-4	Setpoint & Timing Record Form .....	A-19
A-5	Functional Configuration Record Form As Shipped .....	A-33
A-6	Unit Setup and Communication Data Record Form As Shipped .....	A-42
A-7	Setpoint & Timing Record Form As Shipped .....	A-47

**Appendix B**

B-1	Null Modem Cable for M-3311A .....	B-3
B-2	RS-232 Fiber Optic Network .....	B-4
B-3	RS-485 Network.....	B-5

**Appendix D**

D-1	Volts/Hz (24IT) Inverse Curve Family #1 (Inverse Square) .....	D-2
D-2	Volts/Hz (24IT) Inverse Curve Family #2 .....	D-3
D-3	Volts/Hz (24IT) Inverse Time Curve Family #3 .....	D-4
D-4	Volts/Hz (24IT) Inverse Curve Family #4 .....	D-5
D-5	Definite Time Overcurrent Curve .....	D-8
D-6	Inverse Time Overcurrent Curve .....	D-9
D-7	Very Inverse Time Overcurrent Curve .....	D-10
D-8	Extremely Inverse Time Overcurrent Curve .....	D-11
D-9	IEC Curve #1 – Inverse .....	D-12
D-10	IEC Curve #2 – Very Inverse .....	D-13
D-11	IEC Curve #3 – Extremely Inverse.....	D-14
D-12	IEC Curve #4 – Long Time Inverse .....	D-15
D-13	IEEE (Moderately) Inverse Time Overcurrent Curves .....	D-16
D-14	IEEE Very Inverse Time Overcurrent Curves .....	D-17
D-15	IEEE Extremely Inverse Time Overcurrent Curves .....	D-18

**Chapter 1 Installation**

1-1	M-3311A Device Functions .....	1-2
-----	--------------------------------	-----

**Chapter 2 Operation**

2-1	Recorder Partitions .....	2-15
-----	---------------------------	------

**Chapter 4 System Setup and Setpoints**

4-1	Dead Sync Time .....	4-11
4-2	Recorder Partitions .....	4-18
4-3	Input Activated Profile Logic .....	4-24
4-4	Transformer Connections .....	4-76
4-5	Standard Transformer and CT Configuration Options .....	4-77
4-6	Custom Transformer and CT Configuration .....	4-78

**Chapter 5 Installation**

5-1 Circuit Board Jumpers ..... 5-12  
 5-2 Circuit Board Switches ..... 5-12  
 5-3 Trip Circuit Monitor Input Voltage Select Jumper Configuration ..... 5-12

**Chapter 6 Testing**

6-1 Output Contacts ..... 6-3  
 6-2 Input Contacts ..... 6-4

**Appendix A Configuration Forms**

A-1 Relay Configuration ..... A-2  
 A-2 Relay Configuration As Shipped ..... A-61

**Appendix B Communications**

B-1 Communication Port Signals ..... B-3

**Appendix C Error Codes**

C-1 Self-test Error Codes ..... C-1

**Appendix D Inverse Time Curves**

D-1A M-3311A Inverse Time Overcurrent Relay Characteristic Curves ..... D-6  
 D-1B M-3311A Inverse Time Overcurrent Relay Characteristic Curves ..... D-7

# 5 Installation

5.1	General Information .....	5-1
5.2	Mechanical/Physical Dimensions .....	5-1
5.3	External Connections .....	5-6
5.4	Pre-Commissioning Checkout .....	5-10
5.5	Circuit Board Switches and Jumpers .....	5-11
5.6	IPScm <sup>®</sup> Communications Software Installation .....	5-14
5.7	Activating Initial Local Communications .....	5-14
5.8	Initial Setup Procedure .....	5-15

---

## 5.1 General Information

---

■ **NOTE:** Prior to the installation of the equipment, it is essential to review the contents of this manual to locate data which may be of importance during the installation procedures. The following is a quick review of the contents of this chapter.

The person or group responsible for the installation of the relay will find herein all mechanical information required for the physical installation, equipment ratings, and all external connections in this chapter. For reference, the Three-Line Connection Diagrams are repeated from Chapter 4, **System Settings and Setpoints**. Further, a pre-commissioning checkout procedure is outlined using the HMI option to check the external CT and VT connections. Additional tests which may be desirable at the time of installation are described in Chapter 6, **Testing**.

---

## 5.2 Mechanical/Physical Dimensions

---

Figures 5-1 through 5-4 contain physical dimensions of the relay that may be required for mounting the unit to a rack.

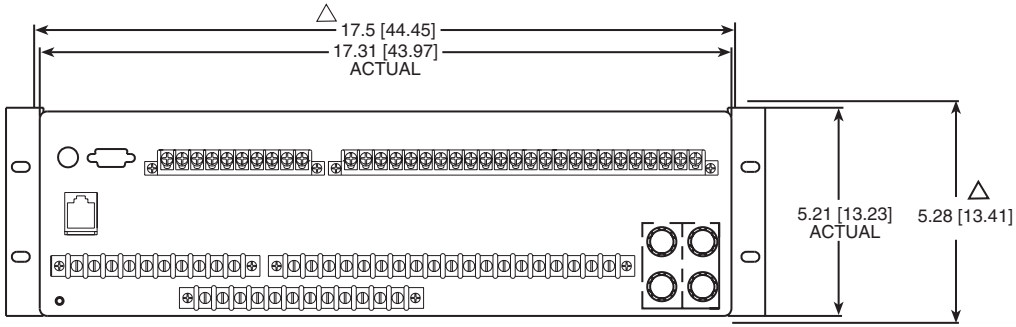

Rear View

△ RECOMMENDED CUTOUT WHEN RELAY IS NOT USED AS STANDARD RACK MOUNT AND IS PANEL CUT OUT MOUNTED

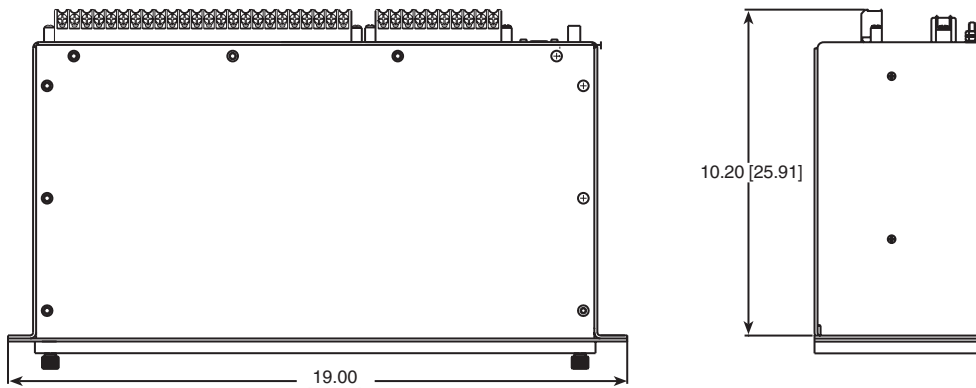

Top View

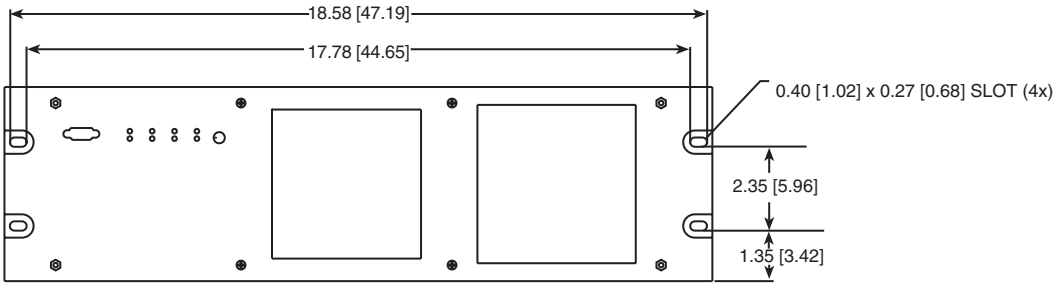

Front View

Standard 19" Horizontal Mount Chassis

■ **NOTE:** Dimensions in brackets are in centimeters.

Figure 5-1 M-3311A Mounting Dimensions – Horizontal Chassis

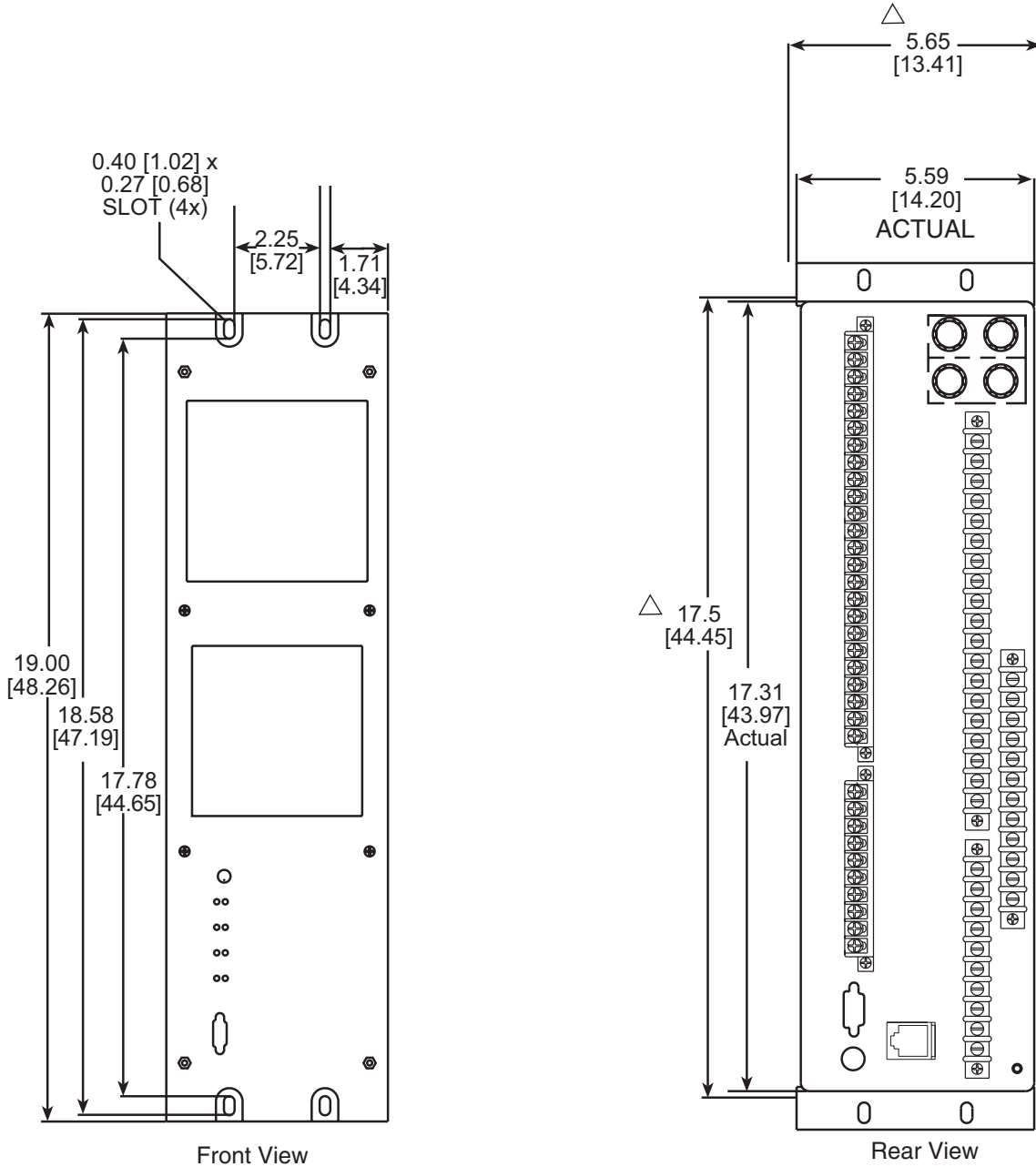

■ **NOTE:** Dimensions in brackets are in centimeters.

△ **RECOMMENDED CUTOUT WHEN RELAY IS NOT USED AS STANDARD RACK MOUNT AND IS PANEL CUT OUT MOUNTED**

### Optional Vertical Mount Chassis

Figure 5-2 M-3311A Mounting Dimensions – Vertical Chassis

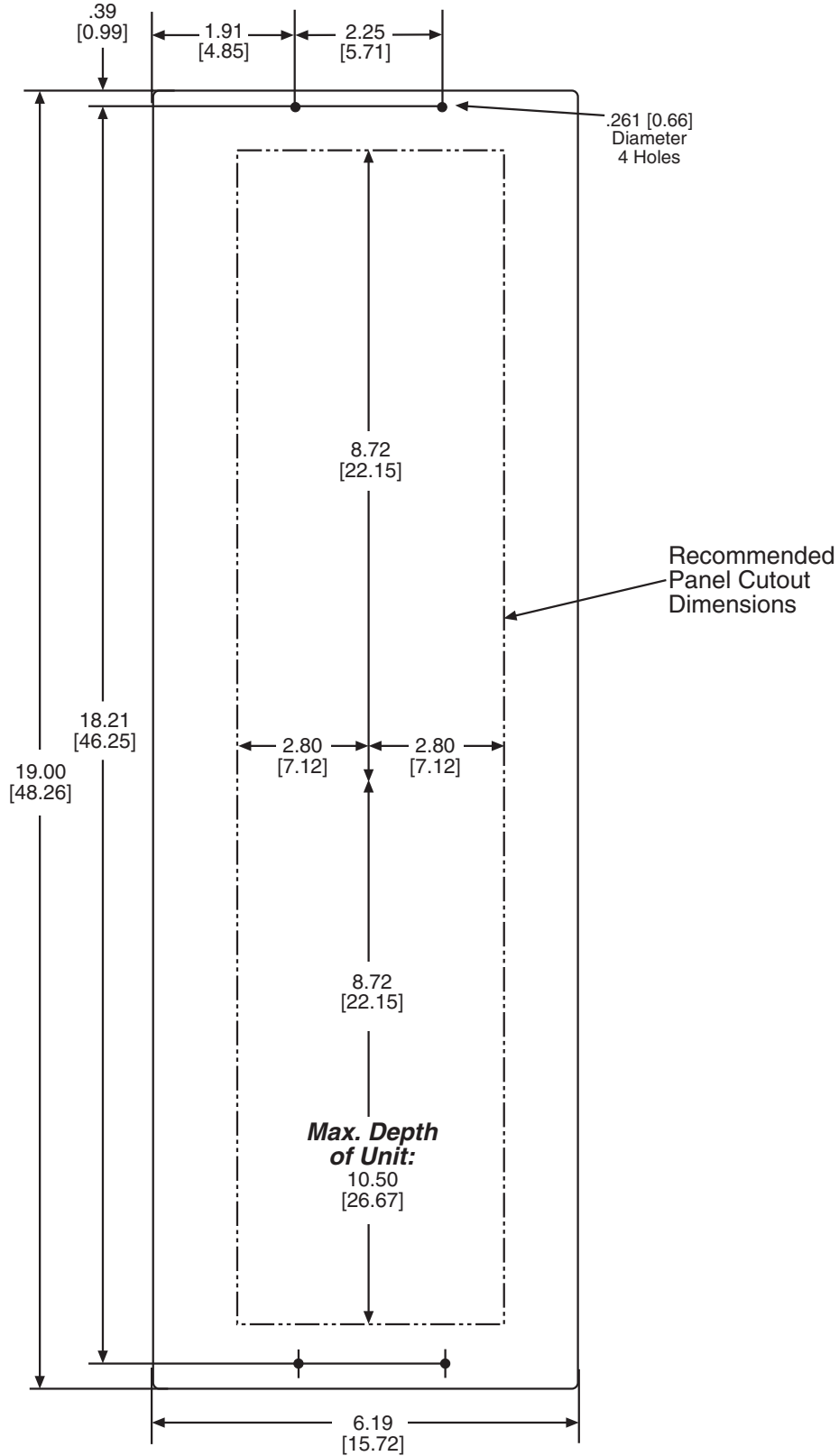

■ **NOTE:** Dimensions in brackets are in centimeters. **Front View**

Figure 5-3 (H2) Mounting Dimensions

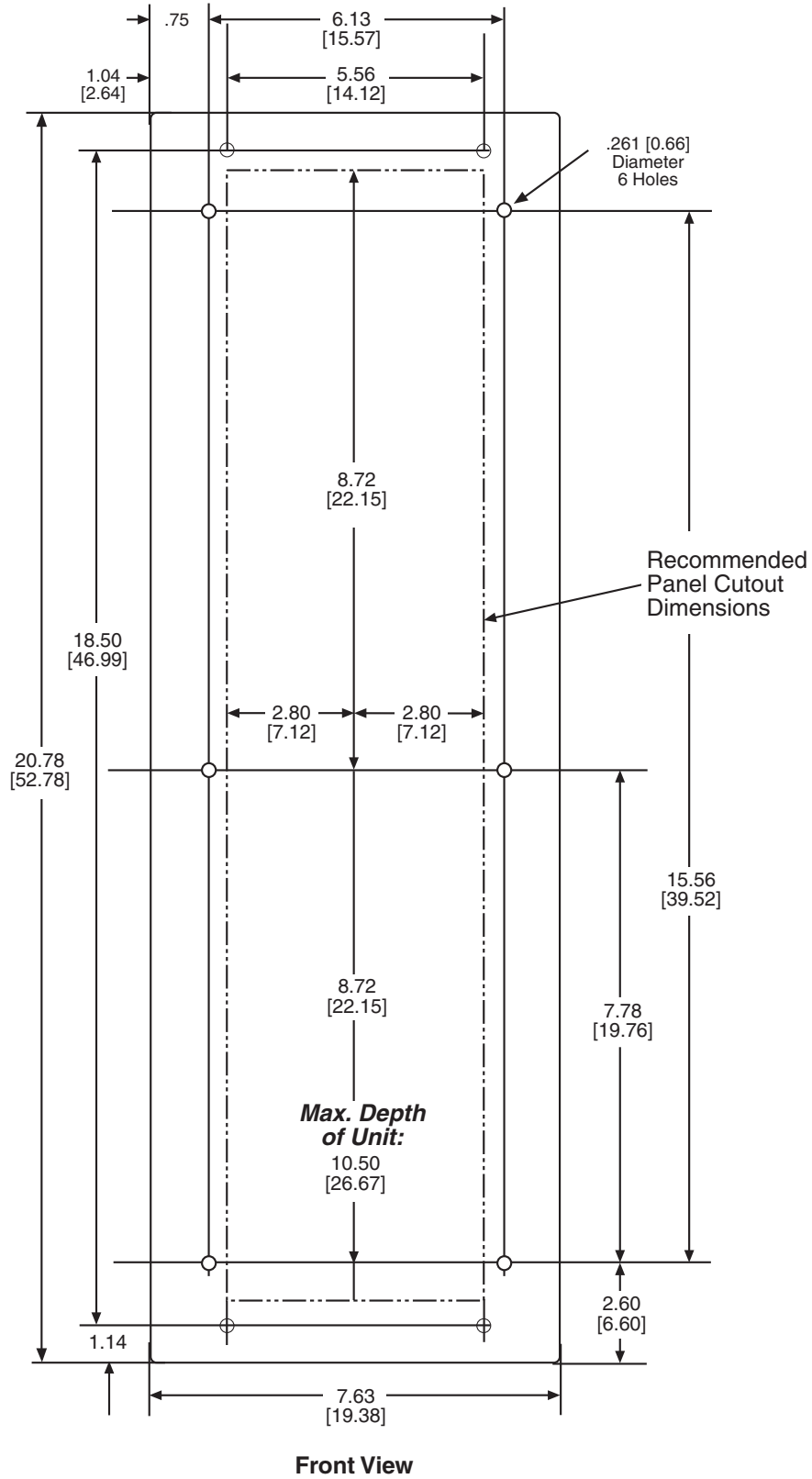

■ NOTE: Dimensions in brackets are in centimeters.

Figure 5-4 (H3) Mounting Dimensions for GE L-2 Cabinet

### 5.3 External Connections

**▲ CAUTION:** The protective grounding terminal must be connected to an earthed ground anytime external connections have been made to the unit.

**▲ CAUTION:** Only dry contacts must be connected to inputs (terminals 5 through 10 with 11 common and terminals 68 through 75 with 66 and 67 common) because these contact inputs are internally wetted. Application of external voltage on these inputs may result in damage to the units.

**● WARNING:** Do not open live CT circuits. Live CT circuits should be shorted prior to disconnecting CT wiring to the M-3311A. Death or severe electrical shock may result.

**▲ CAUTION:** Mis-operation or permanent damage may result to the unit if a voltage is applied to Terminals 1 and 2 (aux) that does not match the configured Trip Circuit Monitoring input voltage.

To fulfill requirements for UL and CSA listings, terminal block connections must be made with No. 12 AWG solid or stranded copper wire inserted in an AMP #324915 (or equivalent) connector, and wire insulation used must be rated at 60° C minimum.

#### Replacement Fuses

F1–F4 replacement fuses must be fast-acting 3 Amp, 250 V (3AB) Beckwith Electric Part Number 420-00885.connector must be tightened to 8-inch pounds torque.

#### Power Supply

When the M-3311A without expanded I/O is equipped with the optional second power supply (Figure 5-8) , the power source may be the same or two different sources.

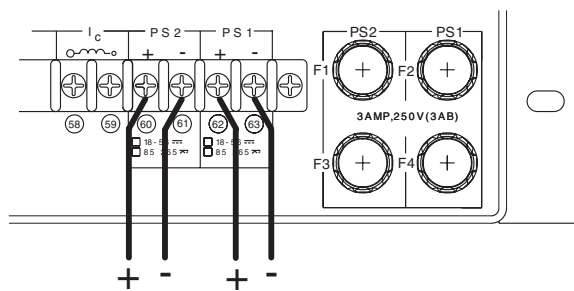

Figure 5-5 Optional Dual Power Supply

When the M-3311A with expanded I/O is equipped with two (not redundant) power supplies, the power supplies must be powered from the same source.

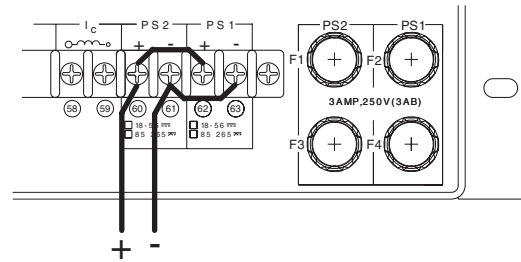

Figure 5-6 Expanded I/O Power Supply

#### Grounding Requirements

The M-3311A is designed to be mounted in an adequately grounded metal panel, using grounding techniques (metal-to-metal mounting) and hardware that assures a low impedance ground.

#### Unit Isolation

Sensing inputs should be equipped with test switches and shorting devices where necessary to isolate the unit from external potential or current sources.

A switch or circuit breaker for the M-3311A's power shall be included in the building installation, and shall be in close proximity to the relay and within easy reach of the operator, and shall be plainly marked as being the power disconnect device for the relay.

#### Insulation Coordination

Sensing Inputs: 60 V to 140 V, Installation Category IV, Transient Voltages not to exceed 5,000 V.

#### Torque Requirements

- **Terminals 1–34 & 66–105:** 7.5 in-lbs, minimum, and 8.0 in-lbs, maximum
- **Terminals 35–75:** 8.5 in-lbs, minimum, and 9.0 in-lbs, maximum

#### Relay Outputs

All outputs are shown in the de-energized state for standard reference. Relay standard reference is defined as protective elements in the non-trip, reconnection and sync logic in the non-asserted state, or power to the relay is removed. Output contacts #1 through #4 are high speed operation contacts. The power supply relay (P/S) is energized when the power supply is OK. The self-test relay is energized when the relay has performed all self-tests successfully.

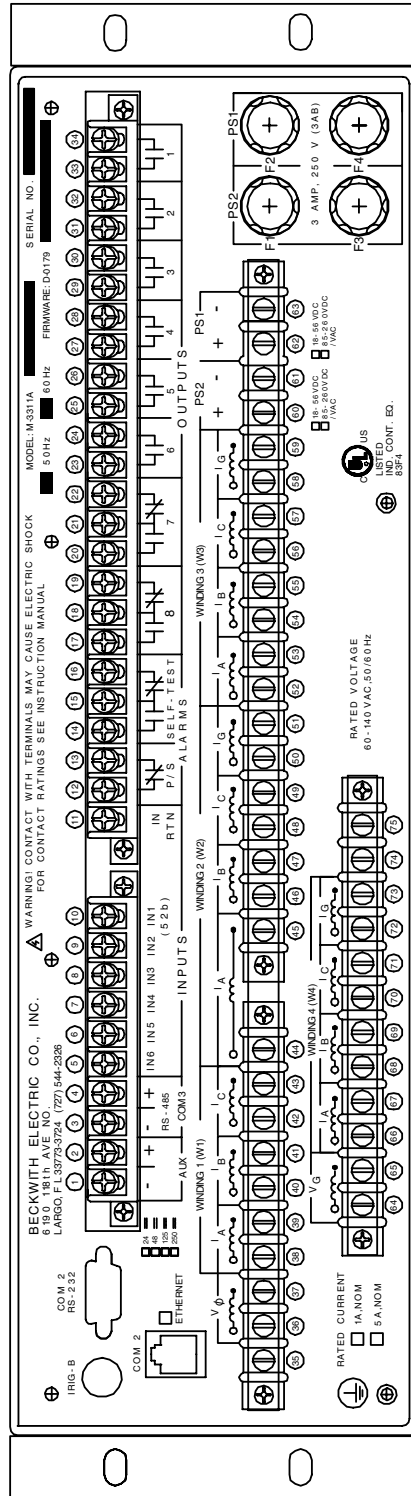

Figure 5-7 Four Winding External Connections

■ NOTES:

1. Output contacts #1 through #4 contain special circuitry for high-speed operation, and close 4 ms faster than outputs 5 through 8. Outputs 1 through 6 are form "a" contacts (normally open) and outputs 7 and 8 are form "c" contacts (center tapped 'a' and 'b' contacts).
2. To comply with UL and CSA listing requirements, terminal block connections must be made with #12 AWG solid or stranded copper wire inserted in an AMP #324915 (or equivalent) connector. Wire insulation must be rated at 60° C minimum. Terminal block connections 1 through 34 must be tightened to 12 inch-pounds torque. Terminal block connections 35 through 63 must be tightened to 8 inch-pounds torque.
3. Only dry contacts must be connected to inputs (terminals 5 through 10 with 11 common) because these contact sensing inputs are internally wetted. **Application of external voltage on these inputs may result in damage to the unit.**
4. All relays are shown in the de-energized state, and without power applied to the relay
5. The power supply relay (P/S) is energized when the power supply is functioning properly.
6. The self-test relay is energized when the relay has performed all self-tests successfully.

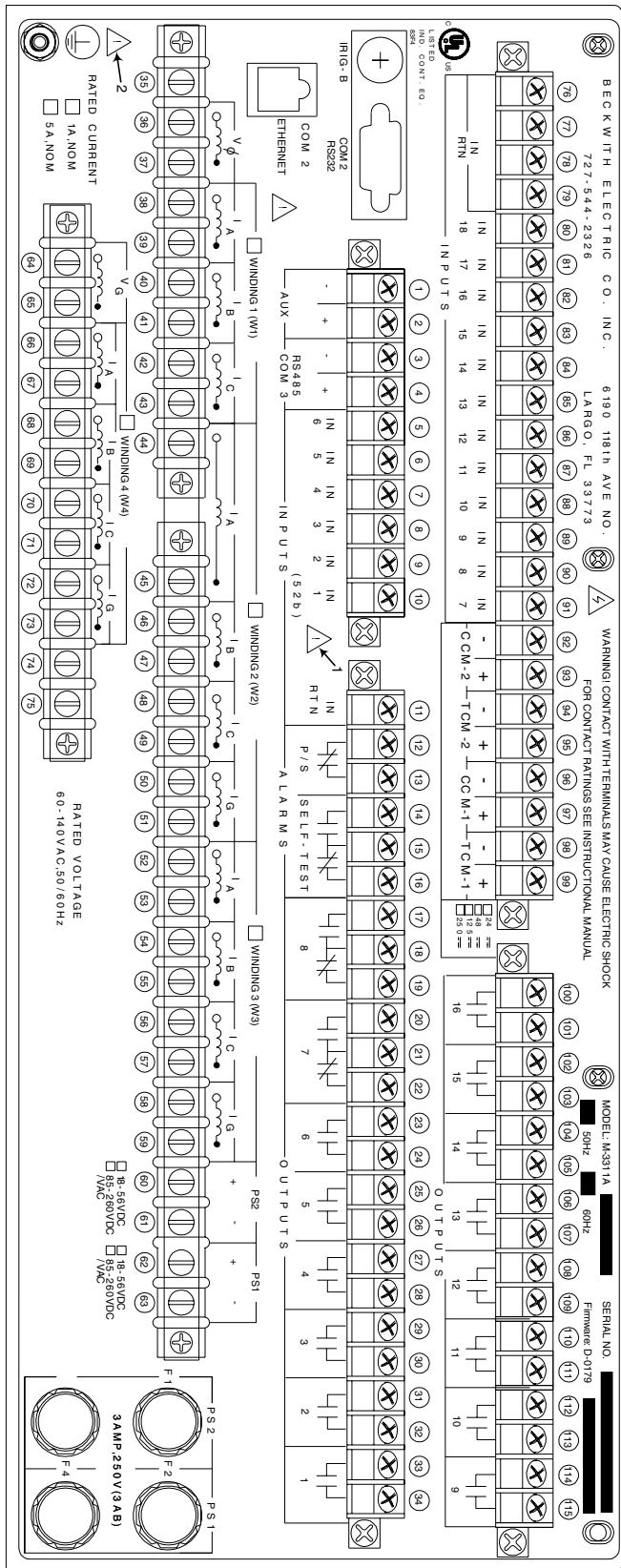

Figure 5-8 M-3311A Four Winding Extended Output Connections

NOTES:

- WARNING:** ONLY DRY CONTACTS must be connected to inputs (terminals 5 through 10 with 11 common and terminals 68 through 75 with 66 and 67 common) because these contact inputs are internally wetted. Application of external voltage on these inputs may result in damage to the units.
- WARNING:** The protective grounding terminal must be connected to an earthed ground any time external connections have been made to the unit.

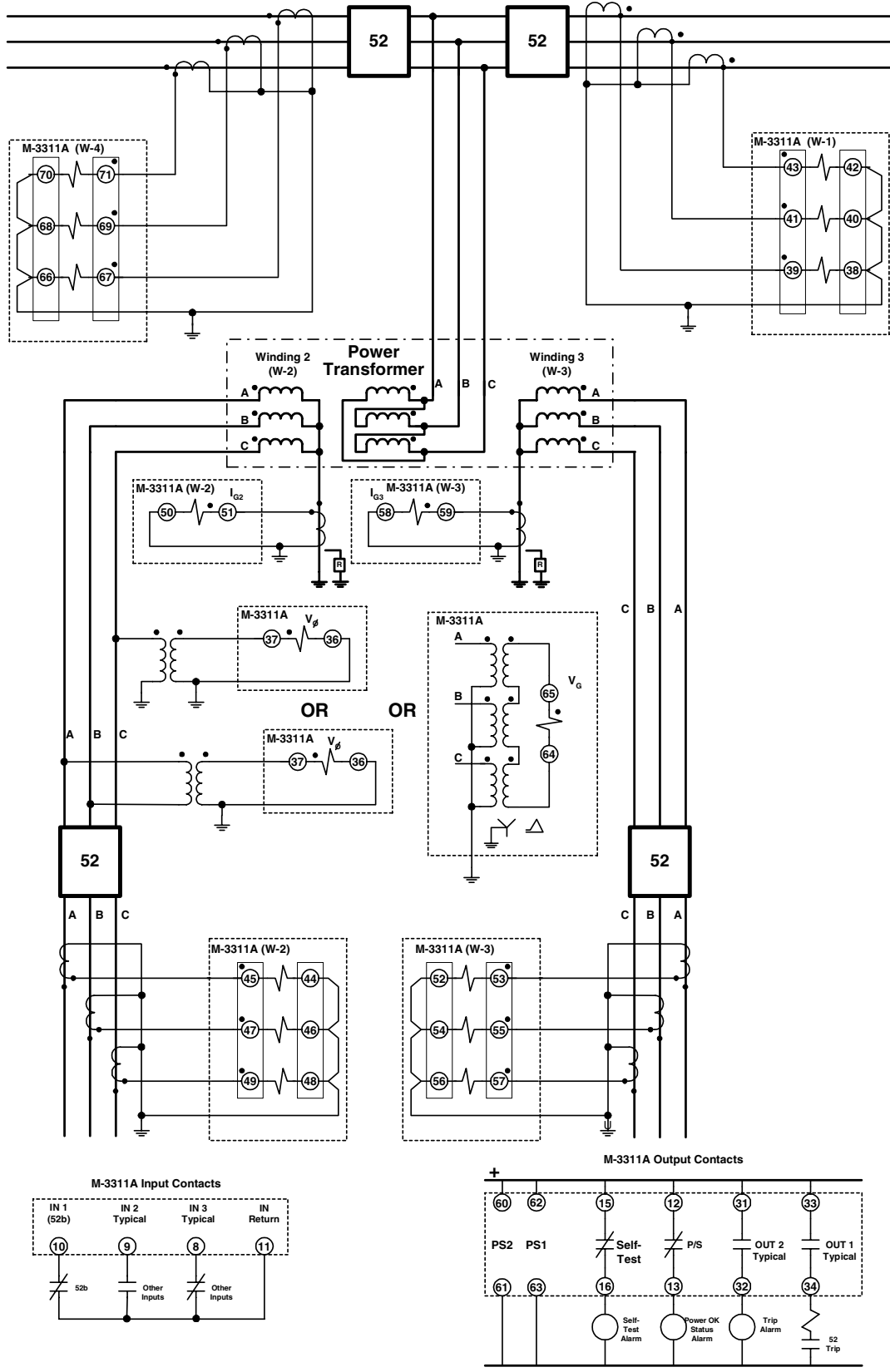

Figure 5-9 Three-Line Connection Diagram

## 5.4 Pre-Commissioning Checkout

During M-3311A Transformer Protection Relay field commissioning, check the following procedure to ensure that the CT and VT connections are correct.

1. On the keypad, press **ENTER**. After a short delay, the unit should display:

VOLTAGE RELAY  
VOLT curr freq v/hz →

2. Press the right arrow button until the unit displays:

STATUS  
←STAT dmd targets→

3. Press **ENTER**. The unit should display:

VOLTAGE STATUS  
VOLT curr freq v/hz →

4. Press **ENTER** to display the phase voltage. Use a voltmeter to compare the actual measurement. If there is a discrepancy, check for loose connections to the rear terminal block of the unit.

VOLTAGE  
AC=

5. Press **EXIT**, the unit displays:

VOLTAGE STATUS  
VOLT curr freq v/hz →

6. Press the right arrow once, the unit displays:

CURRENT STATUS  
volt CURR freq v/hz →

7. Press **ENTER** to display line currents for Winding 1 ( $I_A W_1, I_B W_1, I_C W_1$ ). Compare these currents with the measured values using a meter. If there is a discrepancy, check the CT connections to the rear terminal block of the unit. The unit should display:

W1 PHASE CURRENT  
A= 5.00 B= 5.00 C= 5.00

8. Press **ENTER** to display line currents for Winding 2 ( $I_A W_2, I_B W_2, I_C W_2$ ). Compare these currents with the measured values using a meter. If there is a discrepancy, check the CT connections to the rear terminal block of the unit. The unit should display:

W2 PHASE CURRENT  
A= 5.00 B=5.00 C=5.00

9. Press **ENTER** to display line currents for Winding 3 ( $I_A W_3, I_B W_3, I_C W_3$ ). Compare these currents with the measured values using a meter. If there is a discrepancy, check the CT connections to the rear terminal block of the unit. The unit should display:

W3 PHASE CURRENT  
A= 5.00 B=5.00 C=5.00

10. Press **ENTER** to display line currents for Winding 4 ( $I_A W_4, I_B W_4, I_C W_4$ ). Compare these currents with the measured values using a meter. If there is a discrepancy, check the CT connections to the rear terminal block of the unit. The unit should display:

W4 PHASE CURRENT  
A= 5.00 B=5.00 C=5.00

11. Press **ENTER** for the unit to display ground current. The Ground current should be  $I_G W2 \approx 0$  Amps.

W2 GROUND CURRENT  
0.00 Amps

12. Press **ENTER** for the unit to display ground current. The Ground current should be  $I_G W3 \approx 0$  Amps.

W3 GROUND CURRENT  
0.00 Amps

13. Press **ENTER** for the unit to display ground current. The Ground current should be  $I_G W4 \approx 0$  Amps.

W4 GROUND CURRENT  
0.00 Amps

14. Press **ENTER** for the unit to display restraint currents. The restraint currents should be  $I_{REST} \approx$  for each phase.

RESTRAINT CURRENT (PU)  
A=5.000 B=5.000 C=5.000

15. Press **ENTER** for the unit to display the fundamental differential currents. The fundamental differential currents should be  $I_{DIFF} \approx W_1 - W_2 \approx 0$  for each phase. If a significant amount of differential current is present, check the CT polarities.

DIFF CURRENT FUND. (PU)  
A=0.000 B=0.000 C=0.000

16. Press **ENTER** for the unit to display the second harmonic currents. The second harmonic currents should be  $I_{2ND} \approx 0$  for each phase.

DIFF CURRENT 2nd H (PU)  
A=0.000 B=0.000 C=0.000

17. Press **ENTER** for the unit to display the fourth harmonic currents. The fourth harmonic currents should be  $I_{4TH} \approx 0$  for each phase.

DIFF CURRENT 4th H (PU)  
A=0.000 B=0.000 C=0.000

18. Press **ENTER** for the unit to display the fifth harmonic currents. The fifth harmonic currents should be  $I_{5TH} \approx 0$  for each phase.

DIFF CURRENT 5th H (PU)  
A=0.000 B=0.000 C=0.000

19. Press **ENTER** for the unit to display the ground differential current. The ground differential current should be  $I_{GDIFF} \approx 0$ .

GND DIFFERENTIAL CURRENT  
w2=0.00 w3=0.00 w4=0.00 Amps

20. Press **ENTER** for the unit to display the positive sequence current for winding 1. The positive sequence current should be  $I_{POS} W_1 \approx I_A W_{1,A} \approx I_B W_{1,B} \approx I_C W_{1,C}$ .

W1 POS SEQUENCE CURRENT  
5.00 Amps

21. Press **ENTER** for the unit to display the negative sequence current for winding 1. The negative sequence current should be  $I_{NEG} W_1 \approx 0$  Amps.

W1 NEG SEQUENCE CURRENT  
0.00 Amps

22. Press **ENTER** for the unit to display the zero sequence current for winding 1. The zero sequence current should be  $I_{ZERO} W_1 \approx 0$  Amps. If a significant amount of negative or zero sequence current is present (greater than 25% of  $I_A W_{1,A}$ ,  $I_B W_{1,B}$ ,  $I_C W_{1,C}$ ), then either the phase sequence or the polarities may be incorrect. Modify connections to obtain the correct phase sequence and polarities.

W1 ZERO SEQUENCE CURRENT  
0.00 Amps

23. Repeat steps 18–20 for winding 2, winding 3 and winding 4 currents.

24. Press **EXIT**, the unit displays:

CURRENT STATUS  
volt CURR freq v/hz →

## 5.5 Circuit Board Switches and Jumpers

Dip Jumper	Position	Description
J60	AB	Connects CD signal to COM 2 pin 1*
	AC	Connects +15 V to COM 2 pin 1
J61	BC	Connects -15 V to COM 2 pin 9
	AB	Disconnects COM 2 pin 9*
J18	AB	COM 3 Termination Resistor inserted
	BC	COM 3 Termination Resistor not inserted *
J46	AB	COM 3 shares Baud rate with COM 1
	BC	COM 3 shares Baud rate with COM 2*
J5	AB	Demodulated IRIG-B signal TTL Pin 6
	BC	Modulated IRIG-B signal BNC*

\* Default Setting

Table 5-1 Circuit Board Jumpers

Switch Positions				Description
1	2	3	4	Switches should not be changed while power is applied to unit
U	X	X	X	Up for dual Pwr Supply, down for single
X	X	U	U	Run Mode
X	X	D	D	Factory Use Only
X	X	U	D	Initialize access codes and communication parameters to default values*
X	D	X	X	Flash Update Enabled

\* Power down, set switch, then power up. After power up, the RELAY OK LED light remains off and DIAG LED will illuminate when the operation has been satisfactorily completed.

Table 5-2 Circuit Board Switches

Trip Circuit Monitor Input Voltage Select			
Input Voltage	Jumper J20 Position	Jumper J21 Position	Jumper J22 Position
24 V dc	A to B	A to B	A to B
48 V dc	B to C	A to B	A to B
125 V dc	B to C	B to C	A to B
250 V dc*	B to C	B to C	B to C

\* Default as shipped from factory.

Table 5-3 Trip Circuit Monitor Input Voltage Select Jumper Configuration

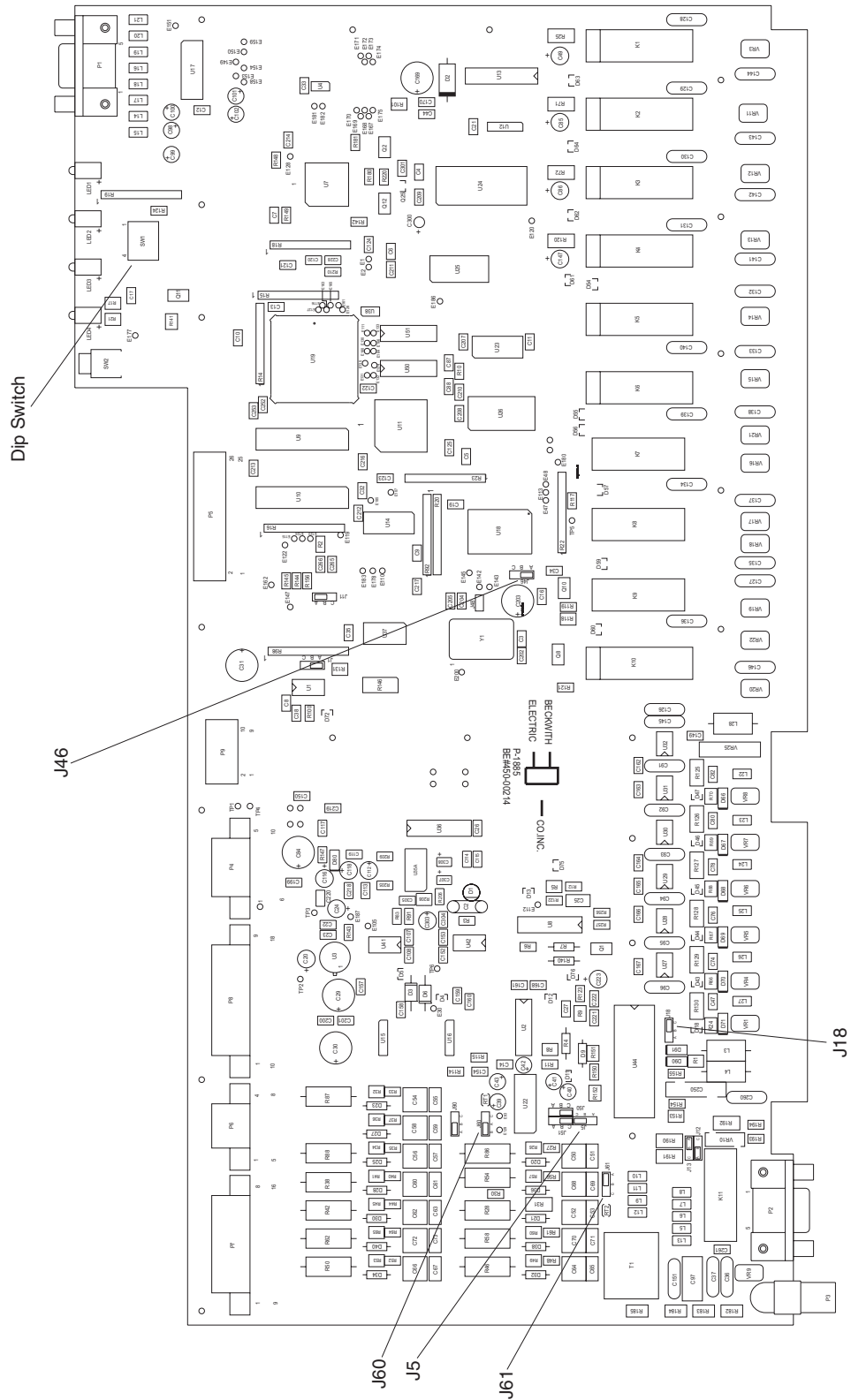

Figure 5-10 M-3311A Circuit Board

## 5.6 IPScm® Communications and Analysis Software Installation

### IPScm Installation and Setup

IPScm runs with the Microsoft Windows® 98 operating system or later. IPScm is available on CD-ROM, or may be downloaded from our website at [www.beckwithelectric.com](http://www.beckwithelectric.com)

The M-3826 IPScm Communications Software is not copy-protected. For more information on your specific rights and responsibilities, see the licensing agreement enclosed with your software or contact Beckwith Electric.

### Hardware Requirements

IPScm will run on any IBM PC-compatible computer that provides at least the following:

- 8 MB of RAM
- Microsoft Windows 98 or later
- CD-ROM drive
- one serial (RS-232) communication port
- pointing device (mouse)

### Installing IPScm

1. Insert software CD-ROM into your drive.

An Auto-Install program will establish a program folder (Becoware) and subdirectory (IPScm). After installation, the IPScm program item icon (see Figure 5-11) is located in Becoware. The default location for the application files is on drive C:, in the new subdirectory "IPScm" (C:\Becoware\IPScm).

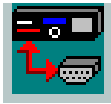

Figure 5-11 IPScm Program Icon

2. If the Auto-Install program does not launch when the CD-ROM is inserted into the drive then proceed as follows:
  - a. Select Run from the Start Menu.
  - b. In the Run dialog screen, locate the installation file (sfi\_m3826Acom\_V\_\_.exe) contained on the IPScm installation disk.
  - c. Select Run to start the installation process.

## 5.7 Activating Initial Local Communications

The relay and IPScm Communications Software are shipped from the factory with the same default communication parameters. Therefore, it may not be necessary to set up communication parameters.

In order for IPScm to communicate with the relay using direct serial connection, a serial "null modem" cable is required, with a 9-pin connector (DB9P) for the relay, and an applicable connector for the computer (usually DB9S or DB25S). Pin-outs for a null modem adapter are provided in Appendix B, **Communications**.

Activating initial communications using default communication parameters is accomplished as follows:

1. Verify that a direct serial connection between the PC hosting IPScm and the target relay COM1 (front) is in place.
2. Select the IPScm icon (Figure 5-11) from the Becoware folder or Desktop. The IPScm **Main Screen** (Figure 3-2) is displayed.
3. Select the **Connect** menu item. IPScm will display the **Serial Port Dialog Screen** (Figure 3-5).
4. If the computer is connected through either an RS-232 port or RS-485 port perform the following:
  - a. Select the **PC Comm Port** that is connected to the relay.
  - b. Select **Connect**. This action attempts to establish communication.
5. If IPScm returns a "COM Opened and Level #(1, 2 or 3) access granted" then communications have been established. Enter any valid IPScm command(s) as desired. To close the communication channel when connected locally, select the **Communication/Disconnect** from the main screen menu bar.

6. If IPScom returns an error message, then determine the relay COM1 communication parameters as follows:

- a. From the relay Front Panel HMI press **ENTER**. The MBTS will display:

VOLTAGE RELAY  
VOLT curr freq v/hz

- b. Press the right arrow pushbutton until the MBTS displays:

COMMUNICATION  
← stat COMM setup →

- c. Press **ENTER**. The relay will display:

COM1 SETUP  
COM1 com2 com3 com\_adr →

- d. Press **ENTER**. The relay will display:

COM1 BAUD RATE  
← baud\_4800 baud\_9600

Record the Baud Rate that is displayed in all Caps: \_\_\_\_\_

- e. Press **EXIT** as necessary to exit the HMI.
- f. Select the **Connect** menu item. IPScom will display the **Serial Port Dialog Screen** (Figure 3-5).
- g. Verify the IPScom COM Port Baud Rate is the same as relay COM1 Baud Rate.
- h. Verify that the **PC Comm Port** that is connected to the relay is selected.
- i. Select **Connect**. This action will attempt to establish communication.
- j. If IPScom returns a "COM Opened and Level #(1, 2 or 3) access granted" then communications have been established. Enter any valid ISScom command(s) as desired.

To close the communication channel when connected locally, select **Communication/Disconnect** from the main screen menu bar.

## 5.8 Initial Setup Procedure

The relay is shipped with the initial configuration settings as listed in Appendix A (see Figure A-4, Functional Configuration Record Form – As Shipped, Figure A-2, Communication Data & Unit Setup - As Shipped, Figure A-3, Setpoint and Timing Record Form – As Shipped, and Table A-2, Relay Configurations – As Shipped) and recorded in the Record forms. Selected settings that are unique to the application may be recorded on the appropriate record form as calculated from Chapter 4, **System Setup and Setpoints**.

### Setup Procedure

1. Connect power to the relay's rear power terminals, as marked on the rear panel's power supply label and as shown in Figures 5-5 and 5-6.
2. When power is initially applied, the M-3311A performs a number of self-tests to ensure its proper operation. During the self-tests, an "X" is displayed for each test successfully executed. If all tests are successful, the unit will briefly display the word **PASS**. Then, a series of status screens, including the model number, software version number, serial number, date and time as set in the system clock, and the user logo screen will be displayed. (Figure 2-2 illustrates this sequence of screens.)
3. If any test should fail, the error LED will flash, an error code will be displayed and the relay will not allow operation to proceed. In such a case, the error code should be noted and the factory contacted. A list of error codes and their descriptions are provided in Appendix C, **Error Codes**. Assuming that various voltage functions are enabled, and there are no voltage inputs connected, various voltage targets will be identified as having operated
4. If remote communication is used, the baud rate, address, and other parameters for the communication ports must be set. Refer to the instructions in Section 5.7, **Activating Initial Local Communications**. Also refer to Chapter 3, **IPScom**, on M-3826 IPScom® Communications Software.

■ **NOTE:** **UNIT SETUP** settings are not considered part of the setpoint profiles. Unit Setup settings are common to all profiles.

■ **NOTE:** Before entering the setup data into the M-3311A, the Communication Data & Unit Setup Record (see Appendix A, Form A.1) should be completed.

5. To setup the unit with general information required, including altering access codes, setting date and time, installing user logos, and other adjustments, refer to Section 4.1, Unit Setup.

■ **NOTE:** The relay has been fully calibrated at the factory using very precise and accurate test equipment. There is no need for recalibration before initial installation. Further calibration is only necessary if a component was changed and will be only as accurate as the test equipment used.

6. If desired, calibrate the unit following the calibration procedure described in subsection 6.3, Auto Calibration. For units without HMI, refer to Section 5.5, Circuit Board Switches & Jumpers.

■ **NOTE:** System Setup settings are not considered part of the setpoint profiles. System Setup settings are common to all profiles.

7. Setup the relay system parameters for the relay application. Section 4.2, System Setup includes the general system and equipment information required for the operation of the relay. This includes such items as CT and VT ratios, VT configurations, transformer connections and Nominal values.

■ **NOTE:** Disabling unused functions improves the response time of the indicators and controls.

8. Enable the desired protective functions for the relay application.

The general information required to complete the input data on this section includes:

- Enable/disable function
- Output choices (OUT1–8)
- Input blocking choices (IN1–6)

The relay is shipped with a certain group of standard functions, including other optional functions, as purchased. Both of these groups define a configurable set of functions. Only members of this set may be enabled/disabled by the end user. (Optional functions not purchased cannot be enabled.)

Functions designated as **DISABLED** are inactive and will not be available for tripping. All menus associated with inactive functions will be unavailable.

9. Enter the desired setpoints for the enabled functions. See Section 4.4, **System Setpoints**.

The general information that is required to complete the input data in this section includes individual relay function:

- Pickup settings (converted to relay quantities)
- Time delay settings
- Time dials

Input descriptions are detailed in Section 4.4, **System Setpoints**. Complete the Setpoint & Timing Record Form in Appendix A before entering the setpoint and time setting data into the relay.

10. Install the M-3311A and connect external input and output contacts according to the rear panel terminal block markings as shown in Figure 5.7, External Connections (5-8 for extended I/O models).

# 6 Testing

6.1	Equipment and Test Setup .....	6-2
6.2	Diagnostic Test Procedures .....	6-3
6.3	Automatic Calibration .....	6-9
6.4	Input Configurations .....	6-10
6.5	Functional Test Procedures .....	6-12
	Power On Self Tests .....	6-13
	24DT Volts/Hz Overexcitation Definite Time (#1 or #2) .....	6-14
	24IT Volts/Hz Overexcitation Inverse Time .....	6-15
	27 Phase Undervoltage .....	6-16
	46DT Negative Sequence Overcurrent Definite Time .....	6-17
	46IT Negative Sequence Overcurrent Inverse Time .....	6-18
	49 Winding Thermal Protection .....	6-19
	50 Instantaneous Phase Overcurrent Winding 1-8 .....	6-21
	50G Instantaneous Ground Overcurrent .....	6-22
	50N Instantaneous Residual Overcurrent .....	6-23
	50BF Breaker Failure .....	6-24
	51 Inverse Time Phase Overcurrent .....	6-26
	51G Inverse Time Ground Overcurrent .....	6-28
	51N Inverse Time Residual Overcurrent .....	6-29
	59G Ground Overvoltage (#1 or #2) .....	6-31
	81 Overfrequency/Underfrequency .....	6-32
	87H Phase Differential Overcurrent .....	6-33
	87T Phase Differential Overcurrent .....	6-34
	87GD Ground Differential (#1, #2) .....	6-37
	BM Breaker Monitoring .....	6-38
	TCM Trip Circuit Monitoring .....	6-40
	TF Through Fault .....	6-41
	IPLogic (#1-6) .....	6-42

---

## 6.1 Equipment and Test Setup

---

No calibration is necessary, as the M-3311A Transformer Protection Relay is calibrated and fully tested at the factory. If calibration is necessary because of a component replacement, follow the Auto Calibration procedure detailed in Section 6.3.

### Required Equipment

The following equipment is required to perform the test procedures outlined in this chapter:

- Two Digital Multimeters (DMM) with a 10 Amp current range. These are not required if using a Pulsar Universal Test System.
- Appropriate power supply for system power.
- Three-phase source capable of 0 to 250 V ac. (Pulsar Universal Test System or equivalent.)
- Three-phase current source capable of 0 to 25 Amps. (Pulsar Universal Test System or equivalent.)
- Electronic timer with a minimum accuracy of 8 msec. (Pulsar Universal Test System or equivalent.)

### Equipment Setup

▲ **CAUTION:** The proper voltage range for the relay is clearly marked on the power supply label affixed to the rear cover.

1. Connect system power to the Relay Power Supply:
  - a. PS1 Terminals 62 (hot) and 63 (neutral)
  - b. PS2 Terminals 60 (hot) and 61 (neutral)
2. Connect the voltage and current sources as indicated in the configuration listed in the individual function test procedure.

## 6.2 Diagnostic Test Procedures

The diagnostic procedures perform basic functional tests to verify the operation of the front panel indicators, inputs, and outputs, and the communication ports. These tests are performed in relay test mode, which is entered in the following manner:

**▲ CAUTION:** The Diagnostic Mode is intended for bench testing the relay only. Do not use the diagnostic mode in relays that are installed in an active protection scheme.

For units with the optional HMI panel:

1. Press the **ENTER** pushbutton.

2. If Level Access is active, the following is displayed:

ENTER ACCESS CODE  
0

- Input the required Access Code, then press **ENTER**.
- If the proper Access Code has been entered, the HMI will return:

LEVEL #(1,2 or 3)  
Access Granted!

VOLTAGE RELAY  
VOLT curr freq v/hz

- Go to step 4.

3. If Level Access is not active, then the following is displayed:

VOLTAGE RELAY  
VOLT curr freq v/hz

**▲ CAUTION:** Do not enter DIAGNOSTIC MODE when protected equipment is in service. Entering DIAGNOSTIC MODE when protected equipment is in service removes all protective functions of the relay.

4. Press the right arrow pushbutton until the following is displayed:

SETUP UNIT  
← stat comm SETUP →

5. Press **ENTER**, the following is displayed:

SOFTWARE VERSION  
VERS sn access number →

6. Press the right arrow pushbutton until the following is displayed:

DIAGNOSTIC MODE  
← time error eth DIAG

7. Press **ENTER**, the following warning will be displayed:

PROCESSOR WILL RESET!  
ENTER KEY TO CONTINUE

**▲ CAUTION:** Do not enter DIAGNOSTIC MODE when protected equipment is in service. Entering DIAGNOSTIC MODE when protected equipment is in service removes all protective functions of the relay.

8. Press **ENTER**, the relay will reset and **DIAGNOSTIC MODE** will be temporarily displayed followed by:

OUTPUT TEST (RELAY)  
OUTPUT input led module →

9. When testing in **DIAGNOSTIC MODE** is complete, press **EXIT** until the following message is displayed:

PRESS EXIT TO  
EXIT DIAGNOSTIC MODE

10. Press **EXIT** again to exit **DIAGNOSTIC MODE**. The relay will reset and then return to normal running mode.

### Output Test (Relay)

The first step in testing the operation of the function outputs is to confirm the positions of the outputs in the unoperated or **OFF** position. This is accomplished by connecting a Digital Multimeter (DMM) across the appropriate contacts and confirming open or closed contact status. The de-energized or **OFF** position for each output is listed in Table 6-1, Output Contacts.

Output Test (Relay)  
OUTPUT input led target

RELAY/OUTPUT NUMBER	NORMALLY OPEN CONTACT*		NORMALLY CLOSED CONTACTS*	
1	33	34	N/A	N/A
2	31	32	N/A	N/A
3	29	30	N/A	N/A
4	27	28	N/A	N/A
5	25	26	N/A	N/A
6	23	24	N/A	N/A
7	21	20	21	22
8	18	17	18	19
9 (Self-Test)	15	14	15	16
10 (Power Supply)	13	12	N/A	N/A

\*"Normal" position of the contact corresponds to the OFF or de-energized state of the relay

Table 6-1 Output Contacts

For units equipped with an optional HMI panel:

Following completion of testing, the output contacts, can be turned **ON** in the following manner:

1. Press **ENTER**. The following is displayed:

RELAY NUMBER  
1

2. Press **ENTER**. The following is displayed:

RELAY NUMBER 1  
OFF on

3. Use the right arrow button to change "on" to uppercase letters, which signifies selection. The following is displayed:

RELAY NUMBER 1  
off ON

4. Press **ENTER**. **Output Relay #1** will energize. The following is displayed:

RELAY NUMBER  
1

5. Choose output numbers 2-8 (2-17 for extended version) by using the up and down arrow buttons to turn all relays or outputs to the energized or **ON** position. When each output is turned on, the appropriate red **OUTPUT** LED illuminates.
6. Use the DMM to verify the position of the output contacts in the energized or **ON** position. The readings should be the opposite of the initial reading above. All outputs should be returned to their initial de-energized or **OFF** positions. The **OUTPUT** LEDs will extinguish when each output is turned off.
7. If Output Relay testing is complete, press **EXIT** to return to the **DIAGNOSTIC MODE** menu.

### Input Test (Status)

The **INPUT TEST** menu enables the user to determine the status of the individual status inputs.

For units equipped with an optional HMI panel:

Each input can be selected by number using the up and down arrow buttons. The status of the input will then be displayed.

INPUT NUMBER	RETURN TERMINAL	INPUT NUMBER
1 (52b)	11	10
2	11	9
3	11	8
4	11	7
5	11	6
6	11	5

Table 6-2 Input Contacts

1. When **OUTPUT TEST (RELAY)** is displayed press the right arrow to display the following:

INPUT TEST  
output INPUT led target→

2. Press **ENTER**. The following is displayed:

INPUT NUMBER  
1

3. Press **ENTER**. The following is displayed:

INPUT NUMBER 1  
CIRCUIT OPEN

4. Connect **IN RTN** (terminal #11) to **IN1**, (terminal #10). See Table 6-2, Input Contacts.

5. Alternatively, if this specific input is being used in the application, and the external wiring is complete, the actual external external status input contact can be manually closed. This will test the input contact operation *and* the external wiring to the input contacts. The following is immediately displayed:

INPUT NUMBER 1  
CIRCUIT CLOSED

6. Disconnect **IN RTN** (terminal #11) from **IN1** (terminal #10). The following is immediately displayed:

INPUT NUMBER 1  
CIRCUIT OPEN

7. Press **ENTER**. The following is displayed:

INPUT NUMBER  
1

8. Use the up arrow button to advance to the next input. Repeat the procedure using the contacts as shown in Table 6-2, Input Contacts.
9. When testing is complete, press **EXIT** to return to the **DIAGNOSTIC MODE** menu.

**Status LED Test**

The **STATUS LED TEST** menu enables the user to check the front panel LED's Individually.

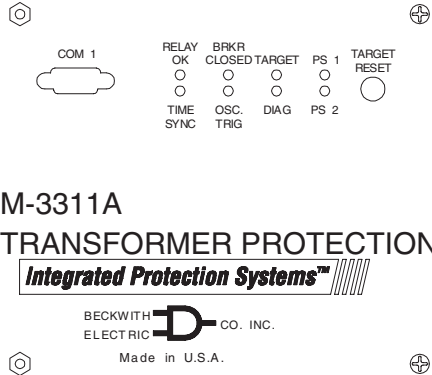

Figure 6-1 Status LED Panel

For units equipped with an optional HMI panel:

1. When **INPUT TESTS (STATUS)** is displayed, press the right arrow button until the following is displayed:

STATUS LED TEST  
output input LED target→

2. Press **ENTER**. LED #1, **RELAY OK**, illuminates and the following is displayed:

STATUS LED TEST  
LED NUMBER 1 = ON

3. Repeat Step 2 for each of the 5 remaining LED's shown in Figure 6-1. The PS1 and PS2 LED's are not subject to this test.
4. When **STATUS LED** testing is complete, press **EXIT** to return to **DIAGNOSTIC MODE**.

**Target LED Test**

■ **NOTE:** This test is not applicable to units that are not equipped with the M-3910 Target Module.

The **TARGET LED TEST** menu allows the user to check the M-3911 Target Module LED's individually.

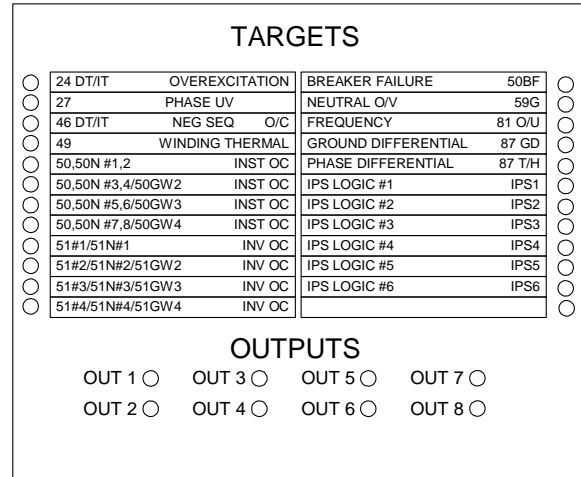

Figure 6-2 M-3911 Target Module

For units equipped with an optional HMI panel:

1. When **STATUS LED TEST** is displayed, press the right button until the following is displayed:

TARGET LED TEST  
output input led TARGET→

2. Press **ENTER**. Target LED #1, **24DT/IT OVEREXCITATION**, illuminates and the following is displayed:

TARGET LED TEST  
LED NUMBER 1 = ON

3. Repeat Step 2 for each of the remaining target and output LED's shown in Figure 6-2.
4. When **TARGET LED** testing is complete, press **EXIT** to return to **DIAGNOSTIC MODE**.

Pressing the **TARGET RESET** button on the front panel also provides a simultaneous test for all **TARGET** LEDs (not applicable in Diagnostic mode).

**Button Test**

■ **NOTE:** This test is only applicable to units that are equipped with the M-3931 HMI Module.

The **BUTTON TEST** menu selection allows the user to check the M-3931 HMI Module Keypad. As each button is pressed, its name is displayed.

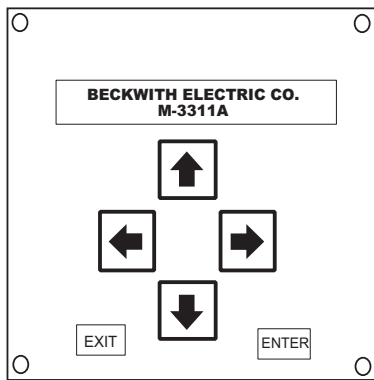

Figure 6-3 M-3931 Human-Machine Interface Module

1. When the **TARGET LED TEST** is displayed, press the right button until the following is displayed:

```
BUTTON TEST
←BUTTON disp com1 com2→
```

2. Press and hold **ENTER**. The following is displayed:

```
BUTTON TEST
ENTER
```

3. Release **ENTER**. The following is displayed:

```
BUTTON TEST
0
```

■ **NOTE:** Pressing the **EXIT** button will terminate this test, so it should be tested last. If it is pressed before the test sequence is complete, the test may be restarted by pressing **ENTER**. Notice the word **EXIT** is displayed temporarily before the test sequence is terminated.

4. Repeat this test for each of the buttons on the keypad and the **TARGET RESET** button. As each button is pressed, the display will briefly show the name for each key (“Right Arrow”, “Up Arrow”, etc).

**Display Test**

■ **NOTE:** This test is only applicable to units that are equipped with the M-3931 HMI Module.

The **DISPLAY TEST** menu selection enables the user to check the alphanumeric display. This test cycles through varying test patterns until the **EXIT** button is pressed.

1. When **BUTTON TEST** is displayed, press the right arrow button until the following is displayed:

```
SCREEN TEST
←button DISP com1 com2→
```

2. Press **ENTER**. The unit will display a sequence of test characters until the **EXIT** button is pressed.
3. After the test has cycled completely through the characters, press **EXIT** to return to the **DIAGNOSTIC MODE** menu.

**Communication Tests**

■ **NOTE:** These tests are only applicable to units that are equipped with the M-3931 HMI Module.

**COM1 and COM2 Test**

The **COM1** and **COM2 LOOPBACK TESTS** allow the user to test the front and rear RS-232 ports for proper operation. These tests require the use of a loop-back plug (see Figure 6-4).

The loopback plug consists of a DB9P connector (male) with pin 2 (RX) connected to pin 3 (TX) and pin 7 (RTS) connected to pin 8 (CTS). No other connections are necessary.

**M-3311A  
COM1/COM2  
DB9P**

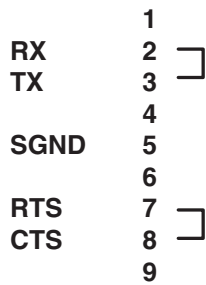

Figure 6-4 COM1/COM2 Loopback Plug

1. When **DISPLAY TEST** is displayed, press the right arrow button until the following is displayed:

COM1 LOOPBACK TEST  
←button disp COM1 com2

2. Press **ENTER**. The following is displayed:

COM1 LOOPBACK TEST  
CONNECT LOOPBACK PLUG

3. Connect the loopback plug to **COM1**, the front-panel RS-232 Connector.
4. Press **ENTER**. After the test, the following is displayed:

COM1 LOOPBACK TEST  
19200 PASS...

5. Press **ENTER** to test each of the baud rates. When all baud rates have been tested, press **ENTER**. The following is displayed:

COM1 LOOPBACK TEST  
-DONE-

6. Press the right arrow until the following is displayed:

COM2 LOOPBACK TEST  
←button disp com1 COM2

7. Repeat steps 2-5 to test **COM2**.

**COM3 Test (2-Wire)**

■ **NOTE:** This test requires a PC with an RS-485 converter and terminal emulator software installed.

The **COM3 ECHO TEST 2 WIRE** allows the user to test the RS-485 rear terminal connections for proper operation.

1. When **COM2 LOOPBACK TEST** is displayed, press the right arrow button until the following is displayed:

COM3 ECHO TEST 2WIRE  
←COM3 clock led coil →

2. Press **ENTER**. The following is displayed:

COM3 ECHO TEST 2WIRE  
IDLING....9600, N, 8, 1

3. On the rear of the unit, connect a PC to the relay at terminals 3 (-) and 4 (+) using an RS-485 converter set for 2 wire operation. See Figure 6-5 for diagram.

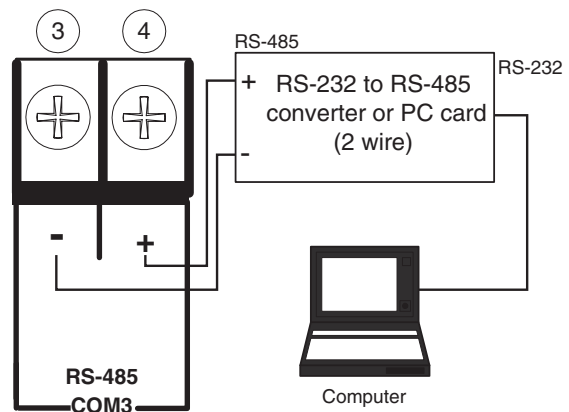

Figure 6-5 RS-485 2-Wire Testing

4. Set the following PC communications parameters:

Baud Rate	9600
Parity	None
Data Bits	8
Stop Bits	1
Duplex	Half

5. Open the terminal emulator program on the PC and open the COM port for the RS-485 converter.

6. Press a key on the PC keyboard. Verify that the character pressed shows temporarily on the display of the relay and appears on the PC monitor.
7. When communications has been verified, press **EXIT**. The following is displayed:

```
COM3 ECHO TEST 2WIRE
-DONE-
```

8. Close the COM port on the PC and exit the terminal emulator program.

**Clock Test**

1. When **COM3 ECHO TEST 2WIRE** is displayed, press the right arrow button until the following is displayed:

```
CLOCK TEST
← com3 CLOCK led cal →
```

2. Press **ENTER**. A display similar to the following is shown:

```
CLOCK TEST
03-JAN-1998 09:00:00.000
```

3. Press **ENTER** again to toggle the clock. If the clock is running, it will stop. If clock has stopped, it will start. The clock stop case is shown below.

```
CLOCK TEST
-CLOCK START-
```

4. Press **ENTER** and verify the relay clock is running. A display similar to the following is shown with the seconds counting:

```
CLOCK TEST
03-JAN-1998 09:0035.000
```

■ **NOTE:** If the unit is removed from service or is to be without power for long periods of time, the clock should be stopped to preserve battery life.

5. Press **ENTER** again to stop the clock. The following is displayed:

```
CLOCK TEST
-CLOCK STOP-
```

6. A display similar to the following is shown with the seconds stopped:

■ **NOTE:** When the relay clock is stopped, the seconds will be displayed as 80.

```
CLOCK TEST
03-JAN-09:01:80.000
```

7. Repeat steps 2 and 3 to restart the clock.

**Flash Relay OK LED**

The **Flash Relay OK LED** function is provided to enable or disable the flashing of the **Relay OK LED**. This function only has effect while the relay is in normal operating mode and will not be noticed while in **Diagnostic Mode**.

The operation of this function may be tested by completing the following steps:

1. When **CLOCK TEST** is displayed, press the right arrow button until the following is displayed:

```
FLASH RELAY OK LED
← com3 clock LED cal →
```

2. Press **ENTER**. The following is displayed:

```
FLASH RELAY OK LED
off ON
```

▲ **CAUTION:** Programming the OK LED to remain illuminated indefinitely is not recommended. It is possible that the LED OK would remain illuminated even if the relay failed.

3. Use the right arrow key to select “on”, and press **ENTER**. The unit will display

```
FLASH RELAY OK LED
-DONE-
```

4. Press **EXIT** to return to the former menu.
5. Repeat step 2 and use the left arrow key to select “off”, and press **ENTER**.
6. Press **EXIT** to return to the former menu.

**Factory Use Only**

This function is provided to allow access by factory personnel.

```
FACTORY USE ONLY
FACTORY
```

### 6.3 Automatic Calibration

The M-3311A Transformer Protection Relay has been fully calibrated at the factory. There is no need to recalibrate the unit prior to installation. Further calibration is only necessary if a component was changed.

For units equipped with an optional M-3931 HMI:

**WARNING: All relay functions and protection will be inoperative while the relay is in Diagnostic Mode.**

1. Navigate to the **Auto Calibration** function in the **Diagnostic Mode** menu. The following is displayed:

AUTO CALIBRATION  
 ← com3 cLock led CAL →

2. Press **ENTER**. The following is displayed:

CONNECT REFERENCE INPUTS  
 PRESS ENTER TO CALIBRATE

3. Connect voltage inputs in parallel to terminal 36,64 (neutral) and terminal 37,65 (hot) and apply 120.00 (±0.01) VAC ∠0°.

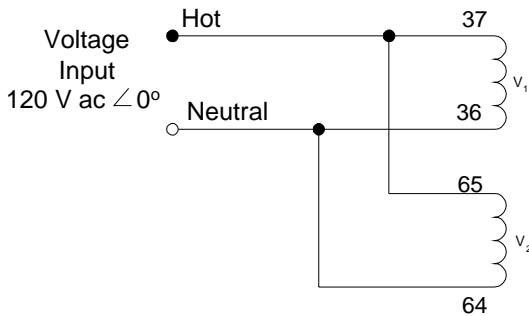

Figure 6-6 Voltage Calibration Configuration

4. Connect all current inputs in series ( $I_A W_1 = I_B W_1 = I_C W_1 = I_A W_2 = I_B W_2 = I_C W_2 = I_G W_2 = I_A W_3 = I_B W_3 = I_C W_3 = I_G W_3 = I_A W_4 = I_B W_4 = I_C W_4 = I_G W_4$ )
5. Apply 5.00 (±0.01) Amps ∠0°. For 1 Amp CT models, use 1.0 (±0.01) Amps ∠0°.

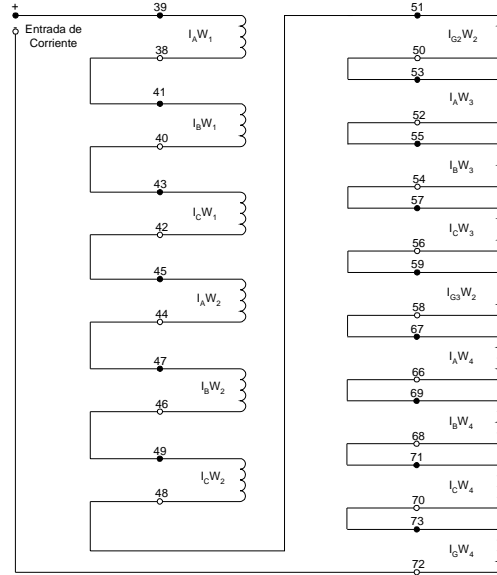

Figure 6-7 Current Calibration Configuration

6. Press **ENTER** to start calibration. While the unit is calibrating, the display will show:

AUTO CALIBRATION  
 -WAIT-

7. When the calibration is complete, unit will display:

AUTO CALIBRATION  
 -DONE-

8. The calibration can be verified by reading the Status (see the **Monitor Status** menu, and Monitor Status/Metering in Section 3.3, Checkout Status & Metering).

For units without the optional M-3931 HMI:

It is possible to autocalibrate M-3311A units that are not equipped with the optional M-3931 HMI. The procedure is similar to HMI equipped units:

1. Remove power from the unit.
2. Place unit in calibrate mode by configuring the proper dip switches (see Table 5-2).
3. Connect voltage inputs.
4. Connect all current inputs in series.
5. Apply power to the unit. **THE DIAG** LED will illuminate when operation is complete.
6. Remove power from the unit, then return dip switches to **RUN** position.

## 6.4 Input Configurations

Phase angles shown here represent leading angles as positive and lagging angles as negative. Some test equipment manufacturers use lagging angles as positive, in which case  $I_B W_1 = \angle 120^\circ$  and  $I_C W_1 = \angle 240^\circ$ . Other current phase angles should be adjusted in the same manner.

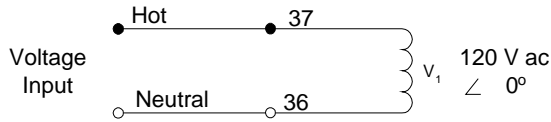

Figure 6-8 Voltage Input, Configuration V1

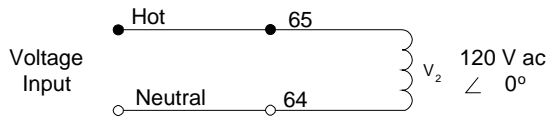

Figure 6-9 Voltage Input, Configuration V2

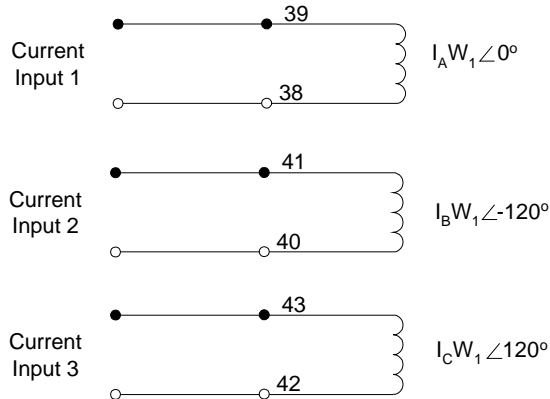

Figure 6-10 Current Inputs, Configuration C1

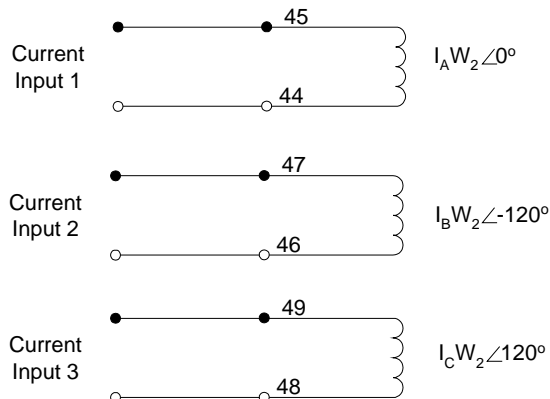

Figure 6-11 Current Inputs, Configuration C2

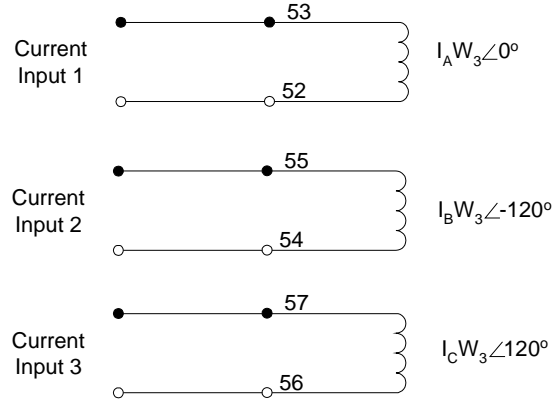

Figure 6-12 Current Inputs, Configuration C3

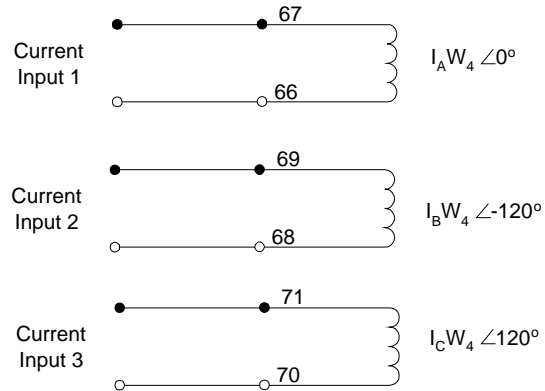

Figure 6-13 Current Inputs, Configuration C4

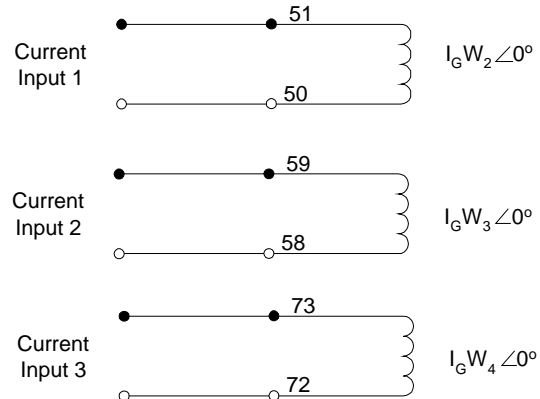

Figure 6-14 Current Inputs, Configuration C5

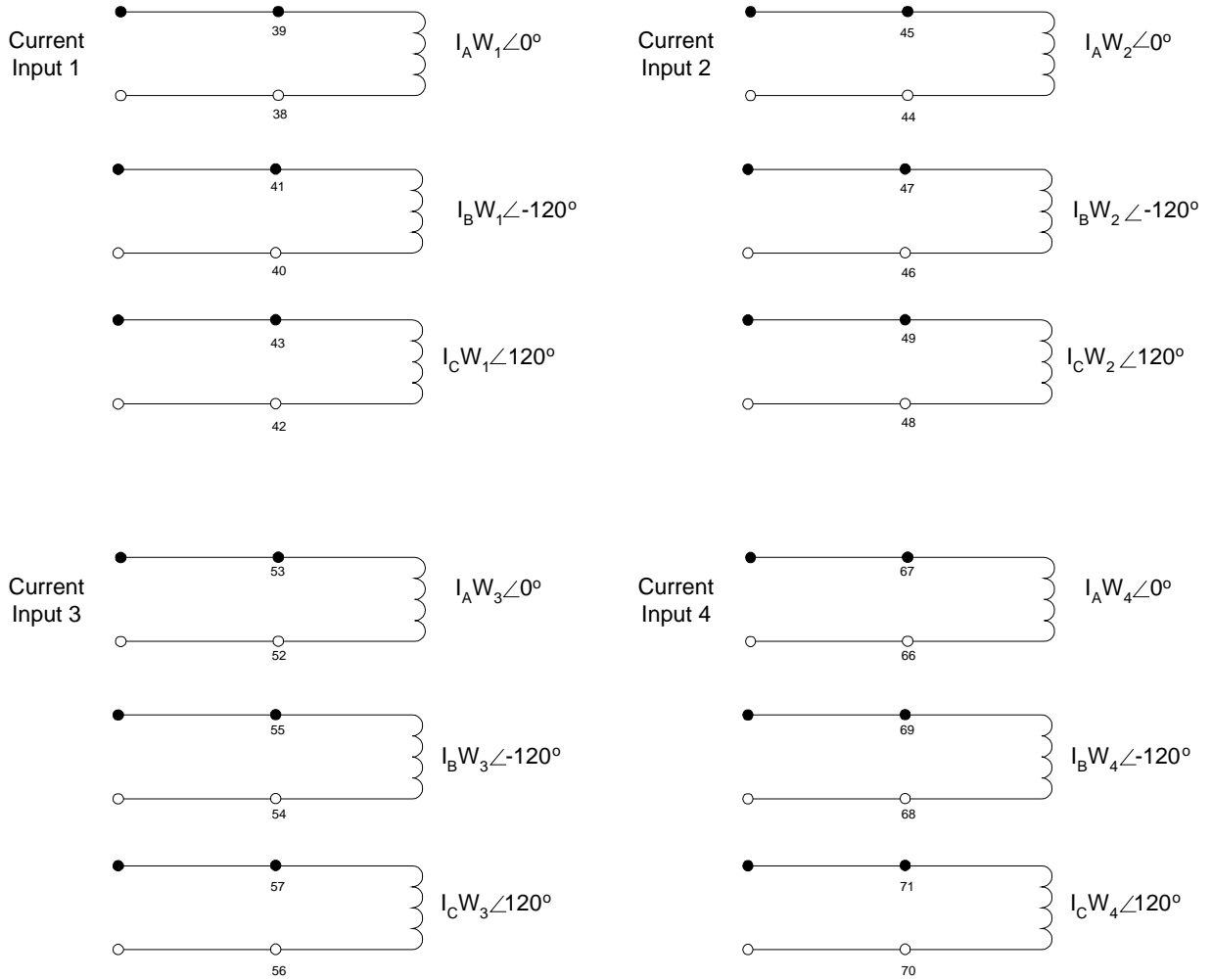

Figure 6-15 Current Configuration C6

## 6.5 Functional Test Procedures

This section details the test quantities, inputs and procedures for testing each function of the relay. The purpose is to confirm the function's designated output operation, the accuracy of the magnitude pickup settings, and the accuracy of time delay settings. Whereas the first test described, "Power On Self Test," does not require electrical quantity inputs, all other functional tests require inputs, and the necessary connection configurations are shown.

In all test descriptions, a process for calculating input quantities to test the actual settings of the function will be given if needed.

**▲ CAUTION:** Care must be taken to reset or re-enable any functions that have been changed from the intended application settings when the test procedures are complete. When a function is re-enabled, both output arrangements and blocking input designations must be reestablished.

In many test cases, it will be necessary to disable other functions not being tested at the time. This action is to prevent the operation of multiple functions with one set of input quantities which could cause confusion of operation of outputs or timers.

The complete description of the method to disable/enable functions may be found in detail in Chapter 2, **Operation**. The complete description of the method to enter setting quantities is found in detail in Chapter 4, **System Setup and Setpoints**.

It is desirable to **record and confirm** the actual settings of the individual functions before beginning test procedures. Use the **FUNCTIONAL CONFIGURATION RECORD FORM** and the **SETPOINT AND TIMING RECORD FORM** found in Appendix A to record settings.

The tests are described in this section in ascending function number order as in Chapter 4, **System Setup and Setpoints**.

During the lifetime of the relay, testing of individual functions due to changes in application settings will be more likely than an overall testing routine. An index of the individual test procedures is illustrated at the beginning of this chapter.

It may be desirable to program all test settings in an alternate profile, or to save the relay settings in IPScm® to preserve a desired setup.

Many options for test sequences and methods are possible. As an example, the operation of the output contacts can be tested along with the operation of the LED's in the Diagnostic Test Procedures. The operation of the output contacts may also be confirmed with the LED and function operation during **Functional Test Procedures**, Section 6.5, if desired.

If timer quantities are to be checked, the timer must be activated by the appropriate output contacts. The contact pin numbers are enumerated in Table 6-1 , Output Contacts.

It is suggested that copies of the following be made for easy referral during test procedures:

- Input Configurations - pages 6–11 and 6–12
- Output Test (Relay)- page 6–4
- Relay Configuration Table - page A–2 and A–3
- Setpoint & Timing Record Form - pages A–18 to A–31

## Power On Self Tests

**VOLTAGE INPUTS:** None

**CURRENT INPUTS:** None

1. Apply proper power to the power input terminals: 60 (hot) and 61 (neutral)
2. The unit will display:

```
POWER ON SELFTESTS
XXXXXXXXXXXXXXXXXXXXX
```

3. All LEDs will illuminate simultaneously for approximately 1 second. The **POWER** and **RELAY OK** LEDs will remain illuminated; the rest of the LEDs will extinguish.
4. The unit will display:

```
POWER ON SELFTESTS
PASS
```

The model number:

```
BECKWITH ELECTRIC CO.
M-3311A
```

where “xx.xx.xx” signifies the software revision;

```
BECKWITH ELECTRIC CO.
D-0179Vxx.xx.xx
```

where “xxx” signifies the unit serial number:

```
BECKWITH ELECTRIC CO.
SERIAL NUMBER XXX
```

The **POWER** LED will illuminate. The **RELAY OK** LED will flash (or remain illuminated as programmed in the **Setup** menu) and the **BREAKER CLOSED** LED will remain illuminated. The Power On Self-Test ends with the system date and time and the default logo. Any recorded targets are then displayed.

**24DT Volts/Hz Overexcitation Definite Time (#1 or #2)**

<b>VOLTAGE INPUTS:</b>	Configuration V1		
<b>CURRENT INPUTS:</b>	None		
<b>TEST SETTINGS:</b>	Definite Time Pickup	P	% (100 to 200)
	Time Delay	D	Cycles (30 to 8160)
	Programmed Outputs	Z	OUT (1 to 8)
		Expanded I/O	(9 to 16)
	Function 24DT #1 or 2	Disable	
	Function 24IT, 27	Disable	
	Function 81O/U	Disable	

1. Disable functions as shown. Refer to Section 4.4, **System Setpoints**, for procedures.
2. Confirm settings to be tested. Only the function being tested should be enabled; the other should be disabled.
3. Connect voltage input in Configuration V1 designated previously. Set the V.T. Configuration (Section 4.2) as V<sub>A</sub>. Refer to Section 6.4, Input Configurations, for configurations.
4. The Volts/Hz pickup level at a percentage setting of nominal frequency (50 or 60Hz) is Definite Time Pickup =  $(P \% \div 100) \times (\text{Nominal Voltage})$ , see example below. The Nominal Values have been programmed in the system setup data described in Section 4.2, **Configuration**, and are recorded on the **COMMUNICATION & UNIT SETUP RECORD FORM**. Test voltage levels may be at any percentage of Nominal Voltage. Choose 4 or 5 test levels and calculate for each.

150% V/Hz	÷ 100	x 120	=180 volts
Pickup (P) setting	divided by 100	times <b>Nominal Voltage</b>	equals voltage level

5. **Voltage Pickup Test:**
  - a. Apply voltage to input contacts at a level 10% lower than the pickup level calculated in Step 4.
  - b. Press and hold the **TARGET RESET** button in, then slowly increase the voltage until the **24DT/IT OVEREXCITATION** LED illuminates or the pickup indicator operates on the computer target screen. The voltage level of operation will be  $P \pm 1\%$ .
  - c. Release the **TARGET RESET** button, then decrease the voltage. The **OUTPUT** LED will extinguish.
  - d. Press the **TARGET RESET** button to remove targets.
6. **Frequency Pickup Test:**
  - a. Apply voltage to input contacts at the Nominal Voltage level.
  - b. Press and hold the **TARGET RESET** button in, then slowly decrease the frequency until the **24DT/IT OVEREXCITATION** LED illuminates or the pickup indicator operates on the computer target screen. The voltage level of operation will be  $P \pm 1\%$ .
  - c. Release the **TARGET RESET** button, then increase frequency to 1% above the pickup frequency. The **OUTPUT** LED will extinguish.
  - d. Press the **TARGET RESET** button to remove targets.

60	÷150% V/Hz	X 100	=40Hz
<b>Nominal Frequency</b>	Pickup (P) setting	times 100	equals frequency level

7. **Timer Test:** With output contacts connected to the timer, apply the calculated voltage from Step 4 and start timing. The contacts will close after **D** cycles within +25 cycles.
8. If testing is complete, enable any functions disabled for this test. If further testing is desired, check the proper functions to disable for the next test and continue from this configuration.

### 24IT Volts/Hz Overexcitation Inverse Time

<b>VOLTAGE INPUTS:</b>	Configuration V1			
<b>CURRENT INPUTS:</b>	None			
<b>TEST SETTINGS:</b>	Inverse Time Pickup	P	%	(100 to 150)
	Inverse Time Curve	C		(1 to 4)
	Time Dial Curve #1	K		(1 to 100)
	Curves #2 to #4			(0.0 to 9.0)
	Reset Rate	R	Sec.	(1 to 999)
	Programmed Outputs	Z	OUT	(1 to 8)
			Expanded I/O	(9 to 16)
	Functions 24DT#1 & 2, 27	Disable		
	Functions 81O/U	Disable		

1. Disable functions as shown. Refer to Section 4.4, **System Setpoints**, for procedures.
2. Confirm settings to be tested.
3. Connect voltage input in Configuration V1 designated previously. Set the V.T. Configuration (Section 4.4) as V<sub>A</sub>. Refer to Section 6.4, Input Configurations, for configurations.
4. The Volts/Hz pickup level at a percentage setting of nominal frequency (50 or 60 Hz) is Definite Time Pickup = (P % ÷ 100) X (Nominal Voltage), see example below. The Nominal Values have been programmed in the system setup data described in Section 4.2, **Configuration**, and are recorded on the **COMMUNICATION & UNIT SETUP RECORD FORM**. Test voltage levels may be at any percentage of Nominal Voltage.

150% V/Hz	÷ 100	x 120	=180 volts
Pickup (P) setting	divided by 100	times	equals voltage level
<b>Nominal Voltage</b>			

5. Test voltage levels may be at any percentage of Nominal Voltage that are a minimum of 5% higher than the selected pickup percentage, P %. It is suggested that 4 or 5 test levels be chosen and voltage level and operating time be calculated for each from the table below.
6. **Timer Test:** With output contacts connected to the timer, apply the calculated voltage from Step 4 and start timing. Operating time will be as calculated in Step 5 (± 1%). Repeat this step for all chosen test levels. The curve portion extending lower than P% V/Hz values is inactive and can be ignored.

$$t = \frac{.003 * K}{\left[\left(\frac{V/Hz\%}{100}\right) - 1\right]^2} \quad t = e^{\frac{115 + (2.5 * K) - V/Hz\%}{4.8858}} \quad t = e^{\frac{113.5 + (2.5 * K) - V/Hz\%}{3.04}} \quad t = e^{\frac{108.75 + (2.5 * K) - V/Hz\%}{2.4429}}$$

**Curve 1**
**Curve 2**
**Curve 3**
**Curve 4**

t = time in minutes K = Time Dial setting V/Hz in percent (%)

7. **Reset Rate Test:** To test the reset rate, begin timing immediately when the input voltage is reduced below pickup value. Holding the **TARGET RESET** button in, stop timing when **24DT/IT OVEREXITATION** LED extinguishes. The time will be the Reset Rate (R) within ± 3 cycles or ± 1%.
8. If re-testing is required, the unit should be powered down or wait for the programmed Reset time period before the next test to ensure complete resetting of the timer.
9. If testing is complete, enable any functions disabled for this test. If further testing is desired, check the proper functions to disable for the next test and continue from this configuration.

## 27 Phase Undervoltage

<b>VOLTAGE INPUTS:</b>	Configuration V1			
<b>CURRENT INPUTS:</b>	None			
<b>TEST SETTINGS:</b>	Pickup	P	Volts	(5 to 140)
	Inhibit Setting	U	Volts	(5 to 140)
	Time Delay	D	Cycles	(1 to 8160)
	Programmed Outputs	Z	OUT	(1 to 8)
		Expanded I/O		(9 to 16)
	Functions 24DT, 24IT	Disable		
	Function 81O/U	Disable		

1. Disable functions as shown. Refer to Section 4.4, **System Setpoints**, for procedures.
2. Confirm settings to be tested.
3. Connect voltage input in Configuration V1 designated previously. Set the V.T. Configuration (Section 4.2) as  $V_A$ . Refer to Section 6.4, **Input Configurations**, for configurations.
4. Set Phase Voltage Inputs at  $1.2 \times P$  volts at the Nominal Frequency.
5. **Pickup Test:**
  - a. Press and hold the **TARGET RESET** button in, then slowly decrease the input phase voltage until the **27 PHASE UV** LED illuminates or the pickup indicator operates on the computer target screen. The level of operation will be  $P$  volts  $\pm 0.5$  V.
  - b. Release the **TARGET RESET** button, then increase the input to the Nominal Voltage. The **OUTPUT** LED will extinguish.
  - c. Press **TARGET RESET** button to remove targets.
6. **Undervoltage Inhibit Test:** Slowly decrease the input voltage until the **27 PHASE UV** LED extinguishes. The level will be  $U$  volts  $\pm 0.5$  volts.
7. **Time Test:** With output contacts connected to the timer, apply approximately 50% of  $P$  volts and start timing. The contacts will close after  $D$  cycles within  $-1$  or  $+3$  cycles or  $\pm 1\%$ .
8. If testing is complete, enable any functions disabled for this test. If further testing is desired, check the proper functions to disable for the next test and continue from this configuration.

## 46DT Negative Sequence Overcurrent Definite Time

<b>VOLTAGE INPUTS:</b>	Configuration V1			
<b>CURRENT INPUTS:</b>	Configuration C2, C3 or C4 (MODIFIED)			
<b>TEST SETTINGS:</b>	Definite Time Pickup	P	Amps	(0.1 to 20)
	1 Amp CT Rating			(0.02 to 4)
	Time Delay	D	Cycles	(1 to 8160)
	Programmed Outputs	Z	OUT	(1 to 8)
		Expanded I/O		(9 to 16)
	Functions 46IT, 49	Disable		
	Function 50N	Disable		
	Functions 50W2, 50W3	Disable		
	Function 51	Disable		
	Function 51N	Disable		
	Function 87H/T	Disable		
	Function 87GD	Disable		

■ **NOTE:** Although a voltage input is not required for the testing of the 46 Function, it is suggested that Nominal Volts be applied to restrain the functions which use both voltage and current inputs for operation. If other functions operate during these tests they should also be disabled for the test and enabled after the tests are complete.

1. Disable functions as shown. Refer to Section 4.2, **System Setpoints**, for procedures.
2. Confirm settings to be tested.
3. Connect inputs in Configuration V1 and C2 (MODIFIED) as designated previously. Refer to Section 6.4, Input Configurations for configurations. The modification to C2 is to exchange Current Input 2 and 3 (BØ current = Input 3 and CØ current = Input 2). Set Voltages = Nominal Voltage. Configuration will be Phase B current from Source 3 and Phase C current from Source 2.

■ **NOTE:** For proper testing use  $I \leq 3 \times \text{CT rating}$ .

4. **Pickup Test:**
  - a. Press and hold the **TARGET RESET** button in, then slowly increase the 3-phase currents until the **46DT/IT NEG SEQ O/C** (46DT/IT NEG SEQ O/C) LED illuminates or the pickup indicator operates on the computer screen. The level of operation will be equal to Pickup Current **P**  $\pm 0.1$  Amp ( $\pm 0.02$  Amp 1 A CT) or  $\pm 3\%$ , whichever is higher.
  - b. Release the **TARGET RESET** button, then decrease the currents to a level below the Pickup Current. The **OUTPUT** LED will extinguish.
  - c. Press the **TARGET RESET** button to remove targets.
5. **Time Test:** With output contacts connected to the timer, apply current of at least 1.1 X Pickup (**P**) and start timing. The contacts will close after (**D**) cycles within  $-1$  or  $+3$  cycles or  $\pm 1\%$ .
6. Reduce input currents to 0 Amps
7. If further testing is desired, check the proper functions to disable for the next test and continue from this configuration.
8. Repeat steps 3, 4, 5, and 6 for Winding 3 and Winding 4.
9. If testing is complete, enable any functions disabled for this test.

### 46IT Negative Sequence Overcurrent Inverse Time

<b>VOLTAGE INPUTS:</b>	Configuration V1		
<b>CURRENT INPUTS:</b>	Configuration C2, C3 or C4 (MODIFIED)		
<b>TEST SETTINGS:</b>	Inverse Time Pickup	P	Amps (0.50 to 5.00)
	1 Amp CT Rating		(0.10 to 1.00)
	Standard Inverse Time Curves: <sup>1</sup>		
	Curve	C	(1 to 4)
	Time Dial	TD	(0.5 to 11.0)
	IEC Inverse Time Curves: <sup>1</sup>		
	IEC Curve	C	(5 to 8)
	IEC Time Dial	TD	(0.05 to 1.10)
	IEEE Inverse Time Curves: <sup>1</sup>		
	IEEE Curve	C	
	IEEE Time Dial	TD	(0.85 to 1.15)
	Programmed Outputs	Z	OUT (1 to 8)
		Expanded I/O	(9 to 16)
	Function 46DT, 49	Disable	
	Function 50W2/W3	Disable	
	Function 51, 51N	Disable	
	Function 87H/87T	Disable	
	Function 87GD	Disable	

1. Disable functions as shown. Refer to Section 4.2, **System Setpoints**, for procedures.
2. Confirm settings to be tested.
3. Connect inputs in Configuration V1 and C2 (MODIFIED) as designated previously. Refer to Section 6.4, **Input Configurations**, for configurations. The modification to C2 is to exchange Current Input 2 and 3 (BØ current = input 3 and CØ current = input 2). Set Voltages = Nominal Voltage.

■ **NOTE:** For proper testing use  $I \leq 3 \times \text{CT rating}$ .

4. **IEC Curve Testing:** Test current level may be chosen as a multiple of any level within the Pickup (P) range. Calculate the operating time for the applied current and appropriate Time Dial (TD) setting from the table below. Choose 4 or 5 test levels and calculate the operating times for each.

IEC Standard Inverse	IEC Very Inverse	IEC Extremely Inverse	IEC Long Time Inverse
$t = \text{TD} \times \left[ \frac{0.14}{M^{0.02} - 1} \right]$	$t = \text{TD} \times \left[ \frac{13.5}{M - 1} \right]$	$t = \text{TD} \times \left[ \frac{80}{M^2 - 1} \right]$	$t = \text{TD} \times \left[ \frac{120}{M - 1} \right]$

*t = time in seconds TD = Time Dial setting M = current in multiples of pickup*

**Standard Curve Testing:** The operating time will be read from Appendix D, Negative Sequence Inverse Time Curves for the applied current and appropriate Time Dial (TD) setting. The curve portions extending to lower than P current values are inactive and can be ignored.

5. **Time Test:** With output contacts connected to the timer, apply currents equal to the multiple of the Inverse Time Pickup (P) and start timing. The operating time will be as calculated in Step 4,  $\pm 3$  cycles or  $\pm 5\%$ . Observe **46DT/IT NEG SEQ O/C** (46 DT/IT NEG SEQ O/C) LED for pickup.
6. If further testing is desired, check the proper functions to disable for the next test and continue from this configuration.
7. Repeat steps 3, 4 and 5 for Winding 3 and Winding 4.
8. If testing is complete, enable any functions disabled for this test.

<sup>1</sup>Either a Standard Curve, IEC Curve or IEEE Curve must be selected.

## 49 Winding Thermal Protection

<b>VOLTAGE INPUTS:</b>	None			
<b>CURRENT INPUTS:</b>	Configuration C1, C2, C3 or C4			
<b>TEST SETTINGS:</b>	Time Constant	$\tau$	Minutes	(1.0 to 999.9)
	Max Overload Current	$I_{max}$	Amps	(1.00 to 10.00)
	1 Amp CT Rating			(0.20 to 2.00)
	Current Selection			(Sum1,Sum2,W1,W2,W3,W4)
	Programmed Outputs	Z	OUT	(1 to 8)
		Expanded I/O		(9 to 16)

### Test Setup:

- Determine the Function 49 Thermal Overload settings to be tested. This test requires that the values for the following elements (described in detail in Chapter 2, **Application**) be determined:
  - $\tau$  = time constant
  - $I_o$  = pre-load current
  - $I_{max}$  = maximum allowed continuous overload current
- Enter the Function 49 Thermal Overload settings to be tested utilizing either the HMI or IPScom® Communications Software.
- Disable all other functions prior to testing. Refer to Section 4.2, **System Setpoints**, Configure Relay Data subsection, for details that describe disabling/enabling functions.
- Connect test current inputs as shown in Figure 6-9, Current Inputs: Configuration C1.
- Calculate  $t$  (time to trip in minutes) for the desired test settings as follows:

Where:

$$t = \tau \times \left( \frac{I_L^2 - I_{PL}^2}{I_L^2 - I_{max}^2} \right)$$

Where:  $t$  = time to trip in minutes

$\tau$  = time constant

$I_L$  = relay current (applied)

$I_{PL}$  = pre-load current

$I_{max}$  = maximum allowed continuous overload current

### Pickup Test:

- Press and hold the **TARGET RESET** pushbutton, then slowly increase the current until the **49 WINDING THERMAL** LED illuminates or the pickup indicator illuminates on the IPScom Function Status screen.  
The current level of operation will be ( $I_{max}$ ) Amps  $\pm 0.1$  A ( $\pm 0.02$  Amp for 1 A CT) or  $\pm 3\%$ .
- Release the **TARGET RESET** pushbutton, then decrease the current. The **OUTPUT** LED will extinguish.
- Press **TARGET RESET** button to remove targets.

**Time Test (Cold Start):**

1. Connect a timer to output contacts (**Z**) so that the timer stops timing when the contacts (**Z**) close.

■ **NOTE:** The 49 Thermal Overload 49 current value can be obtained utilizing either the HMI (Status/Current Status) or IPScm® Communications Software (Relay/Monitor/Secondary Status).

2. Determine the 49 Thermal Overload 49 current value. If the value is greater than 0.00 A, then remove power from the relay and then reapply power to reset the current value.
3. Apply a three phase current (**I**) to the relay greater than ( $I_{max}$ ) Amps and start timing.  
The time to trip should be  $t$  minutes  $\pm 5\%$ .

**Time Test (Preload):**

1. Connect a timer to output contacts (**Z**) so that the timer stops timing when the contacts (**Z**) close.

■ **NOTE:** The 49 Thermal Overload 49 current value can be obtained utilizing either the HMI (Status/Current Status) or IPScm Communications Software (Relay/Monitor/Secondary Status).

2. Determine the 49 Thermal Overload 49 current value. If the value is greater than 0.00 A, then remove power from the relay and then reapply power to reset the current values.
3. Apply a three phase preload current to the relay equal to ( $I_o$ ) Amps and allow current readings to stabilize.
4. Apply a three phase current (**I**) to the relay greater than ( $I_{max}$ ) Amps and start timing.  
The time to trip should be  $t$  minutes  $\pm 5\%$ .

## 50 Instantaneous Phase Overcurrent 1-8

<b>VOLTAGE INPUTS:</b>	None			
<b>CURRENT INPUTS:</b>	Configurations C1, C2, C3, C5			
<b>TEST SETTINGS:</b>	50W1 Pickup	P	Amps	(1.0 to 100)
	1 Amp CT Rating			(0.2 to 20)
	Current Selection		(Sum1, Sum2, W1, W2, W3, W4)	
	Time Delay	D	Cycles	(1 to 8160)
	Programmed Outputs	Z	OUT	(1 to 8)
		Expanded I/O		(9 to 16)
	Function 46IT	Disable		
	Function 49	Disable		
	Function 50W2/W3	Disable		
	Function 50N	Disable		
	Function 51	Disable		
	Function 51N	Disable		
	Function 87GD	Disable		

1. Disable functions as shown. Refer to Section 4.2, **System Setpoints**, for procedures.
2. Confirm settings to be tested. Only the winding being tested should be enabled; the others should be disabled.
3. Connect inputs in Configuration C1 as designated previously. Refer to Section 6.4, **Input Configurations**, for configurations.
4. Select W1 in Winding Config Setpoint.

■ **NOTE:** Special attention must be taken as to which winding is being tested and which winding is disabled when changing setpoints.

5. **Pickup Test:**
  - a. Press and hold the **TARGET RESET** button in, then slowly increase current input 3 (C phase) until the selected winding target LED illuminates or the pickup indicator operates on the computer target screen. The current level of operation will be (**P**) Amps  $\pm 0.1$  A ( $\pm 0.02$  Amp 1 A CT) or  $\pm 3\%$ .
  - b. Release the **TARGET RESET** button, then decrease the current. The **OUTPUT** LED will extinguish.
  - c. Press **TARGET RESET** button to remove targets. This test may be repeated for each of the other phases.
6. **Time Test:** With output contacts (**Z**) connected to the timer, apply current 5% above pickup (**P**) Amps and start timing. The operating time will be (**D**) cycles within  $\pm 2$  cycles or 1%.
7. Repeat Steps 4 and 5 for windings W2, W3 and W4 using configurations C2, C3, and C4.
8. **Winding Summing Test:** Later
9. If testing is complete, enable any functions disabled for this test. If further testing is desired, check the proper functions to disable for the next test and continue from this configuration.

## 50G Instantaneous Ground Overcurrent

<b>VOLTAGE INPUTS:</b>	None			
<b>CURRENT INPUTS:</b>	Configuration C4			
<b>TEST SETTINGS:</b>	50GW2/W3/W4 Pickup	P	Amps	(1.0 to 100.0)
	1 Amp CT Rating			(0.2 to 20.0)
	Programmed Outputs	Z	OUT	(1 to 8)
		Expanded I/O		(9 to 16)
	Function 51G	Disable		
	Function 87GD	Disable		

1. Disable functions as shown. Refer to Section 4.2, **System Setpoints**, for procedures.
2. Confirm settings to be tested.
3. Connect the inputs in Configuration C5 as designated previously. Refer to Section 6.4, **Input Configurations**, for configurations. The other current phases remain disconnected.
4. **Pickup Test:**
  - a. Press and hold the **TARGET RESET** button in, then slowly increase the  $I_G W_2$  current until the **50,50N #3,4/50GW2 INST OC** LED illuminates or the pickup indicator operates on the computer target screen. The level of operation will be **P** Amps  $\pm 0.1$  A ( $\pm 0.02$  Amp 1 A CT) or  $\pm 3\%$ .
  - b. Release the **TARGET RESET** button, then decrease the current. The **OUTPUT** LED will extinguish.
  - c. Press **TARGET RESET** button to remove targets. This test may be repeated for each of the other phases.
5. **Time Test:** With output contacts (**Z**) connected to the timer, apply approximately 5% above pickup (**P**) amps and start timing. The operating time will be (**D**) cycles within  $\pm 2$  cycles or 1%.
6. Repeat Steps 4 and 5, using  $I_G W_3$  ( $I_G W_4$ ). Observe the winding being tested LED for pickup.
7. If testing is complete, enable any functions disabled for this test. If further testing is desired, check the proper functions to disable for the next test and continue from this configuration.

## 50N Instantaneous Residual Overcurrent

**VOLTAGE INPUTS:** Configuration V1

**CURRENT INPUTS:** As Described

<b>TEST SETTINGS:</b>	Pickup	P	Amps	(1.0 to 100.0)
	1 Amp CT Rating			(0.2 to 20.0)
	Current Selection		(Sum1, Sum2, W1, W2, W3, W4)	
	Time Delay	D	Cycles	(1 to 8160)
	Programmed Outputs	Z	OUT	(1 to 8)
		Expanded I/O		(9 to 16)
	Functions 46DT, 46IT	Disable		
	Function 49	Disable		
	Function 50 1-8	Disable		
	Function 50BF	Disable		
	Function 51	Disable		
	Function 51N	Disable		
	Function 87H/T	Disable		

1. Disable functions as shown. Refer to Section 4.2, **System Setpoints**, for procedures.
2. Confirm settings to be tested.
3. Connect inputs in Configuration V1 and C1 (MODIFIED). Set to Nominal Voltage. See Section 6.4, **Input Configurations**, for configurations. Modification to C1 is to set all three currents to phase angle  $\angle 0^\circ$ .
4. Select W1 in Winding Config Setpoint.
5. **Pickup Test:**
  - a. Press and hold the **TARGET RESET** button in, then slowly increase the phase current until the selected winding target LED illuminates or the pickup indicator operates on the computer target screen. The current level of operation will be (**P**) Amps  $\pm 0.1$  A ( $\pm 0.02$  Amp 1A CT) or  $\pm 3\%$ .
  - b. Release the **TARGET RESET** button, then decrease the current. The **OUTPUT** LED will extinguish.
  - c. Press **TARGET RESET** button to remove targets.
6. **Time Test:** With output contact (**Z**) connected to the timer, apply approximately 5% above pickup (**P**) amps, and start timing. The operating time will be (**D**) cycles within  $\pm 2$  cycles or 1%.
7. Repeat steps 4 and 5 using current Configuration C2 (modified), C3 (modified) and C4 (modified). Observe the selected winding target LED for pickup.
8. **Winding Summing Test:** Later
9. If testing is complete, enable any functions disabled for this test. If further testing is desired, check the proper functions to disable for the next test and continue from this configuration.

## 50BF Breaker Failure

<b>VOLTAGE INPUTS:</b>	Configuration V1		
<b>CURRENT INPUTS:</b>	As Described		
<b>TEST SETTINGS:</b>	50BFW1/W2/W3/W4 Phase Pickup	P	Amps (0.10 to 10.00)
	1 Amp CT Rating		(0.02 to 2.00)
	50BFW1/W2/W3/W4 Residual Pickup	N	Amps (0.10 to 10.0)
	1 Amp CT Rating		(0.02 to 2)
	Time Delay	D	Cycles (1 to 8160)
	Programmed Outputs	Z	OUT (1 to 8)
		Expanded I/O	(9 to 16)
	Functions 46DT, 46IT		Disable
	Function 49		Disable
	Function 50 1-8		Disable
	Function 50N		Disable
	Function 51		Disable
	Function 51N		Disable
	Function 87H/T		Disable
	Function 87GD		Disable

1. Disable functions as shown. Refer to Section 4.2, **System Setpoints**, for procedures.
2. Confirm settings to be tested. Only the winding being tested should be enabled; the others should be disabled.
3. Connect inputs in Configuration C1 designated previously. Refer to Section 6.4, **Input Configurations**, for configurations.

■ **NOTE:** For proper testing use  $I \leq 3 \times \text{CT rating}$ .

4. Select an input for 50BF Input Initiate (**IN**) and enter the number.
5. Place a jumper from Terminal **11** (RTN) to the selected input terminal (**IN**) on the rear of the unit.
6. Verify that all Output Initiates (**OUT**) are disabled.
7. **Phase Pickup Test:**
  - a. Press and hold the **TARGET RESET** button in, then slowly increase 3-phase current until the **BREAKER FAILURE 50BF** LED illuminates or the pickup indicator operates on the computer target screen. The level of operation will be **P** Amps  $\pm 0.1$  Amps ( $\pm 0.02$  Amps 1 A CT) or  $\pm 2\%$ .
  - b. Release the **TARGET RESET** button, then decrease the 3-phase current. The **OUTPUT** LED will extinguish.
  - c. Press **TARGET RESET** button to remove targets.

8. **Residual Pickup Test (Residual Current):**

- a. Set the 50BF phase to a current higher than the residual pickup to prevent the 50BF phase from tripping.
- b. Connect the inputs in Configuration C1 (modified), designated previously. The modification to C1 is to set all three currents to phase angle  $\angle 0^\circ$ . In this configuration, the applied value of  $I_G$  is equal to the applied 3-phase currents.
- c. Press and hold the **TARGET RESET** button in, then slowly increase Winding 1 currents until the **BREAKER FAILURE 50BF** LED illuminates or the pickup indicator operates on the computer target screen. The level of operation will be (**P**) Amps,  $\pm 0.1$  Amps ( $\pm 0.02$  Amps 1 A CT) or  $\pm 2\%$
- d. Release the **TARGET RESET** button, then decrease the current. The **OUTPUT** LED will extinguish.
- e. Press **TARGET RESET** button to remove targets.

■ **NOTE:** When calculating values for residual current functions, phase levels must be added together. For example:  $3I_0 = I_A + I_B + I_C$  must be used to calculate pickup time.

9. **Timer Test :** With output contacts (**Z**) connected to the timer, apply approximately 110% of above Pickup (**P**) Amps and start timing. The operating time will be **D** cycles within  $-1$  or  $+3$  cycles or  $\pm 2\%$ .

■ **NOTE:** Both the 50BF Phase and Residual Functions use the same timer, therefore, it is only necessary to perform this test once.

10. Reduce input currents to 0 Amps.
11. Repeat Steps 4 through 10 using current Configuration C2 (modified), C3 (modified) and C4 (modified). Observe **BREAKER FAILURE 50BF** LED for pickup.
12. If testing is complete, enable any functions disabled for this test. If further testing is desired, check the proper functions to disable for the next test and continue from this configuration.

## 51 Inverse Time Phase Overcurrent

<b>VOLTAGE INPUTS:</b>	None		
<b>CURRENT INPUTS:</b>	Configuration C1 or C2 or C3 or C4		
<b>TEST SETTINGS:</b>	51W1/W2/W3/W4 Pickup	P	Amps (0.50 to 12.00)
	Current Selection		(Sum1, Sum2, W1, W2, W3, W4)
	1 Amp CT Rating		(0.1 to 2.4)
	Standard Inverse Time Curves: <sup>1</sup>		
	Curve	C	(1 to 4)
	Time Dial	TD	(0.5 to 11.0)
	IEC Inverse Time Curves: <sup>1</sup>		
	IEC Curve	C	(5 to 8)
	IEC Time Dial	TD	(0.05 to 1.10)
	IEEE Inverse Time Curves: <sup>1</sup>		
	IEEE Curve		
	IEEE Time Dial		(0.85 to 1.15)
	Programmed Outputs	Z	OUT (1 to 8)
		Expanded I/O	(9 to 16)
	Functions 46DT, 46IT	Disable	
	Function 49		
	Function 50 1-8	Disable	
	Function 50N	Disable	
	Function 51N	Disable	
	Function 87H/T	Disable	
	Function 87GD	Disable	

1. Disable functions as shown. Refer to Section 4.2, **System Setpoints**, for procedures.
2. Confirm settings to be tested. Only the winding being tested should be enabled; the others should be disabled.
3. Connect current inputs in Configuration C1 as designated previously. See Section 6.4, **Input Configurations**, for configurations.
4. Select W1 in Winding Config Setpoint.

■ **NOTE:** Special Attention must be paid as to which winding is being tested and which winding is disabled.

5. Refer to Appendix D. Calculate test times for levels represented on the graphs. It is suggested that 4 or 5 test levels be chosen.
6. **Time Test:** With output contacts connected to the timer, apply currents used in calculations from step 4 and start timing. The operating time will be **(D)** cycles within  $\pm 3$  cycles or 3% of calculated time. Repeat this step for each test level chosen. The tested points verify the operation of this function.

<sup>1</sup>Either a Standard Curve, IEC Curve or IEEE Curve must be selected.

7. Observe selected winding target LED for pickup.

<b>IEC Standard Inverse</b>	<b>IEC Very Inverse</b>	<b>IEC Extremely Inverse</b>	<b>IEC Long Time Inverse</b>
$t = TD \times \left[ \frac{0.14}{M^{0.02} - 1} \right]$	$t = TD \times \left[ \frac{13.5}{M - 1} \right]$	$t = TD \times \left[ \frac{80}{M^2 - 1} \right]$	$t = TD \times \left[ \frac{120}{M - 1} \right]$

*t = time in seconds TD = Time Dial setting M = current in multiples of pickup*

8. Repeat Steps 4 and 5 using Configurations C2, C3 and C4. Observe the selected winding target LED for pickup.
9. If testing is complete, enable any functions disabled for this test. If further testing is desired, check the proper functions to disable for the next test and continue from this configuration.

### 51G Inverse Time Ground Overcurrent

<b>VOLTAGE INPUTS:</b>	None		
<b>CURRENT INPUTS:</b>	Configuration C4		
<b>TEST SETTINGS:</b>	51GW2/W3 Pickup	P	Amps (0.50 to 12.00)
	1 Amp CT Rating		(0.1 to 2.4)
	Standard Inverse Time Curves: <sup>1</sup>		
	Curve	C	(1 to 4)
	Time Dial	TD	(0.5 to 11.0)
	IEC Inverse Time Curves: <sup>1</sup>		
	IEC Curve	C	(5 to 8)
	IEC Time Dial	TD	(0.05 to 1.10)
	IEEE Inverse Time Curves: <sup>1</sup>		
	IEEE Curve	C	
	IEEE Time Dial		(0.85 to 1.15)
	Programmed Outputs	Z	OUT (1 to 8) Expanded I/O (9 to 16)
	Function 50G		Disable
	Function 87GD		Disable

1. Disable functions as shown. Refer to Section 4.2, **System Setpoints**, for procedures.
2. Confirm settings to be tested. Only the winding being tested should be enabled; the others should be disabled.
3. Connect current inputs in Configuration C5 as designated previously. See Section 6.4, **Input Configurations**, for configurations.
4. Refer to Appendix D. Calculate test times for levels represented on the graphs. It is suggested that 4 or 5 test levels be chosen.

<b>IEC Standard Inverse</b>	<b>IEC Very Inverse</b>	<b>IEC Extremely Inverse</b>	<b>IEC Long Time Inverse</b>
$t = TD \times \left[ \frac{0.14}{M^{0.02} - 1} \right]$	$t = TD \times \left[ \frac{13.5}{M - 1} \right]$	$t = TD \times \left[ \frac{80}{M^2 - 1} \right]$	$t = TD \times \left[ \frac{120}{M - 1} \right]$

*t = time in seconds TD = Time Dial setting M = current in multiples of pickup*

5. **Time Test:** With output contacts connected to the timer, apply currents used in calculations from Step 4 and start timing while observing selected winding target LED for pickup. The operating time will be (D) cycles within ±3 cycles or ±3% of calculated time.
6. Repeat Step 5 for each test level chosen.
7. Repeat Steps 4, 5 & 6 using Currents  $I_G W_3$ ,  $I_G W_4$  while observing the selected winding target LED for pickup.
8. If testing is complete, enable any functions disabled for this test. If further testing is desired, check the proper functions to disable for the next test and continue from this configuration.

<sup>1</sup>Either a Standard Curve, IEC Curve or IEEE Curve must be selected.

### 51N Inverse Time Residual Overcurrent

<b>VOLTAGE INPUTS:</b>	None		
<b>CURRENT INPUTS:</b>	As Described		
<b>TEST SETTINGS:</b>	51N W1/W2/W3/W4 Pickup 1 Amp CT Rating	P	Amps (0.5 to 6) (0.1 to 1.2)
	Current Selection		(Sum1, Sum2, W1, W2, W3, W4)
	Standard Inverse Time Curves: <sup>1</sup> Curve	C	(1 to 4)
	Time Dial	TD	(0.5 to 11)
	IEC Inverse Time Curves: <sup>1</sup> IEC Curve	C	(5 to 8)
	IEC Time Dial	TD	(0.05 to 1.1)
	IEEE Inverse Time Curves: <sup>1</sup> IEEE Curve	C	
	IEEE Time Dial		(08.5 to 1.15)
	Programmed Outputs	Z	OUT (1 to 8) Expanded I/O (9 to 16)
	Functions 46DT, 46IT, 49		Disable
	Function 50 1-8		Disable
	Function 50N		Disable
	Functions 51, 87H/T, 87GD		Disable

1. Disable functions as shown. Refer to Section 4.2, **System Setpoints**, for procedures.
2. Confirm settings to be tested. Only the winding being tested should be enabled; the others should be disabled.
3. Connect current inputs in Configuration C1 (modified). See Section 6.4, **Input Configurations**, for configurations. The modification to C1 is to set all three currents to phase angle  $\angle 0^\circ$ . In this configuration, the applied value of  $I_G$  is equal to the applied 3-phase currents.

■ **NOTE:** Special Attention must be paid to which winding is being tested and which winding is disabled.

4. Refer to Appendix D. Calculate test times for levels represented on the graphs. It is suggested that 4 or 5 test levels be chosen.

IEC Standard Inverse	IEC Very Inverse	IEC Extremely Inverse	IEC Long Time Inverse
$t=TD \times \left[ \frac{0.14}{M^{0.02} - 1} \right]$	$t=TD \times \left[ \frac{13.5}{M - 1} \right]$	$t=TD \times \left[ \frac{80}{M^2 - 1} \right]$	$t=TD \times \left[ \frac{120}{M - 1} \right]$

*t = time in seconds TD = Time Dial setting M = current in multiples of pickup*

■ **NOTE:** When calculating values for residual current functions, phase levels must be added together. For example:  $3I_0 = I_A + I_B + I_C$  must be used to calculate pickup time.

5. **Time Test:** With output contacts connected to the timer, apply input current used in calculations from Step 4 and start timing while observing the selected winding target LED for pickup. The operating time will be (D) cycles within  $\pm 3$  cycles or 3% of calculated time.

<sup>1</sup>Either a Standard Curve, IEC Curve or IEEE Curve must be selected.

6. Repeat Step 5 for each test level chosen. The tested points verify the operation of this function.
7. Repeat Steps 4, 5 & 6 using Configuration C2 (modified), C3 (modified) and C4 (modified). Observe the selected winding target LED for pickup.
8. **Winding Summing Test:** Later
9. If testing is complete, enable any functions disabled for this test. If further testing is desired, check the proper functions to disable for the next test and continue from this configuration.

**59G Ground Overvoltage (#1 or #2)**

<b>VOLTAGE INPUTS:</b>	Configuration V1			
<b>CURRENT INPUTS:</b>	None			
<b>TEST SETTINGS:</b>	59G Pickup	P	Volts	(5 to 180)
	Time Delay	D	Cycles	(1 to 8160)
	Programmed Outputs	Z	OUT	(1 to 8)
		Expanded I/O		(9 to 16)
	Function 81O/U	Disable		

1. Disable functions as shown. Refer to Section 4.2, **System Setpoints**, for procedure.
2. Confirm settings to be tested.
3. Connect input in Configuration V2 as designated previously. Set the V.T. Configuration (Section 4.2) as  $V_G$ . See Section 6.4, **Input Configurations**, for configurations.
4. **Pickup Test:**
  - a. Press and hold the **TARGET RESET** button, then slowly increase the input voltage until **NEUTRAL OVERVOLTAGE 59G** LED illuminates or the pickup indicator operates on the computer target screen. The level should be equal to (**P**) volts  $\pm 0.5$  V or  $\pm 0.5\%$ .
  - b. Release the **TARGET RESET** button, then decrease the input voltage. The **OUTPUT** LED will extinguish.
  - c. Press **TARGET RESET** button to remove targets.
5. **Time Test:** With output contracts being connected to the timer, apply (**P+1**) Volts and start timing. The operating time will be (**D**) cycles within  $\pm 1$  cycle or  $\pm 1\%$ .
6. If testing is complete, enable any functions disabled for this test. If further testing is desired, check the proper functions to disable for the next test and continue from this configuration.

## 81 Overfrequency/Underfrequency

<b>VOLTAGE INPUTS:</b>	Configuration V1			
<b>CURRENT INPUTS:</b>	None			
<b>TEST SETTINGS:</b>	Pickup	P	Hz	(55 to 65)
	50 Hz Relay			(45 to 55)
	Time Delay	D	Cycles	(2 to 65,500)
	Programmed Outputs	Z	OUT	(1 to 8)
		Expanded I/O		(9 to 16)
	Functions 24DT, 24IT	Disable		

1. Disable functions as shown. Refer to Section 4.2, **System Setpoints**, for procedure.
2. Confirm settings to be tested.
3. Connect inputs in Configuration V1 designated previously. Set the V.T. Configuration (Section 4.2) as  $V_A$ . Refer to Section 6.4, **Input Configurations** for configuration.
4. **Pickup Test:**

■ **NOTE:** When using single-phase frequency sources, connect the source to one voltage input.

- a. Set the voltages to the Nominal Frequency. Single-phase frequency sources may be used.
  - b. Press and hold the **TARGET RESET** button in, then slowly decrease the frequency of the input voltage until the **FREQUENCY 81 O/U** LED illuminates or the pickup indicator operates on the computer target screen. The level of operation will be equal to **P** Volts  $\pm 0.1$  Hz.
  - c. Release the **TARGET BUTTON**, then return to nominal input frequency. The **OUTPUT LED** will extinguish.
  - d. Press **TARGET RESET** button to remove targets.
5. **Time Test:** With output contacts being connected to the timer, input (**P** – 0.5) Hz and start timing. The operating time will be (**D**) cycles within –1 to +3 cycles or  $\pm 1\%$ .
  6. Complete the testing for the remaining 81 functions by repeating Steps 4 and 5, above.
  7. If testing is complete, enable any functions disabled for this test. If further testing is desired, check the proper functions to disable for the next test and continue from this configuration.

## 87H Phase Differential Overcurrent

<b>VOLTAGE INPUTS:</b>	None			
<b>CURRENT INPUTS:</b>	Configuration C6			
<b>TEST SETTINGS:</b>	Pickup	P	PU	(5.0 to 20.0)
	Time Delay	D	Cycles	(1 to 8160)
	Programmed Outputs	Z	OUT	(1 to 8)
		Expanded I/O		(9 to 16)
	Functions 46IT, 49	Disable		
	Function 50 1-8	Disable		
	Function 50N, 50BF	Disable		
	Function 51, 51N	Disable		

1. Disable functions as shown. Refer to Section 4.2, **System Setpoints**, for procedure.
2. Confirm settings to be tested.
3. Connect inputs in Configuration C5 as designated previously. Refer to Section 6.4, **Input Configurations** for configuration. For testing purposes it is recommended that the CT Tap Corrections, **CT1**, **CT2**, **CT3** and **CT4** be set to 1.0. If it is desired to test with other CT Tap settings, the current values must be computed by using the following formulas:

$I_A W_1$  (Applied) =  $I_A W_1$  (Calculated) multiplied by CT1.

$I_A W_2$  (Applied) =  $I_A W_2$  (Calculated) multiplied by CT2.

$I_A W_3$  (Applied) =  $I_A W_3$  (Calculated) multiplied by CT3.

$I_A W_4$  (Applied) =  $I_A W_4$  (Calculated) multiplied by CT4.

■ **NOTE:** All values used for this function are measured in *PU*s, which requires calculating the actual current in Amps to be used for testing: 1 **PU** = CT Tap.

4. **Minimum Pickup Test:**
  - a. Set the  $I_A W_1$  (input 1) = 0 Amps.
  - b. Press and hold the **TARGET RESET** button in, then slowly increase  $I_A W_2$  (Input 2) until the **PHASE DIFFERENTIAL 87T/H** LED illuminates or the pickup indicator operates on the computer target screen. The level of operation will be equal to (**P**) *PU*'s  $\pm 0.1$  *PU* or  $\pm 3\%$ .
  - c. Release the **TARGET RESET** button, then decrease the current. The **OUTPUT** LED will extinguish.
  - d. Press **TARGET RESET** button to remove targets. This test may be repeated for testing the opposite winding or another phase.
5. **Timer Check:** With output contacts being connected to the timer, apply at least 10% higher  $I_A W_2$  (Input 2) current than the minimum pickup level and start timing. The operating time will (**D**) cycles within  $-1$  to  $+3$  cycles or  $\pm 1\%$ .
6. If desired, repeat Steps 4 & 5 setting  $I_A W_2$  (input 2) and/or  $I_A W_3$  (input 3) or ( $I_A W_4$ ) to 0 Amps and increasing  $I_A W_1$  (Input 1).
7. If testing is complete, enable any functions disabled for this test. If further testing is desired, check the proper functions to disable for the next test and continue from this configuration.

## 87T Phase Differential Overcurrent

**VOLTAGE INPUTS:** None

**CURRENT INPUTS:** Configuration C6

<b>TEST SETTINGS:</b>	Pickup	P	PU	(0.10 to 1.00)
	Percent Slope #1	S1	%	(5 to 100)
	Percent Slope #2	S2	%	(5 to 200)
	Slope Break Point	BP	PU	(1.0 to 4.0)
	Even Harmonics Restraint (2nd and 4th)	E	E,D,A	ENABLE/DISABLE/ ENABLE WITH CROSS AVERAGE
	Restraint		%	(5 to 50)
	5 <sup>th</sup> Harmonic Restraint	E	E,D,A	
	Restraint		%	(5 to 50)
	Pickup at 5 <sup>th</sup> Harmonic Restraint	FP	PU	(0.10 to 2.00)
	CT Tap W1/W2/W3/W4	CT1/2/3/4		(1 to 100.0)
	1 Amp CT Rating			(0.2 to 20.00)
	Programmed Outputs	Z	OUT	(1 to 8)
		Expanded I/O		(9 to 16)
	Functions 46IT, 49		Disable	
	Function 50 1-8		Disable	
	Function 50N, 50BF		Disable	
	Function 51, 51N		Disable	

1. Disable functions as shown. Refer to Section 4.2, **System Sepoints**, for procedure.
2. Confirm settings to be tested.
3. Connect inputs in Configuration C5 as designated previously. Refer to Section 6.4, **Input Configurations** for configuration. For testing purposes it is recommended that the CT Tap Corrections, **CT1**, **CT2**, **CT3** and **CT4** be set to 1.0. If it is desired to test with other CT Tap settings, the current values must be computed by using the following formulas:

$$I_A W_1 (\text{Applied}) = I_A W_1 (\text{Calculated}) \text{ multiplied by CT1.}$$

$$I_A W_2 (\text{Applied}) = I_A W_2 (\text{Calculated}) \text{ multiplied by CT2.}$$

$$I_A W_3 (\text{Applied}) = I_A W_3 (\text{Calculated}) \text{ multiplied by CT3.}$$

$$I_A W_4 (\text{Applied}) = I_A W_4 (\text{Calculated}) \text{ multiplied by CT4.}$$

■ **NOTE:** All values used for this function are measured in *PU*s, which requires calculating the actual current in Amps to be used for testing: 1 PU = CT Tap.

4. **Minimum Pickup Test:**
  - a. Set  $I_A W_1$  (input 1) = 0 Amps.
  - b. Press and hold the **TARGET RESET** button, then slowly increase  $I_A W_2$  (Input 2) until the **PHASE DIFFERENTIAL 87T/H** LED illuminates, or the pickup indicator operates on the computer target screen. The level of operation will be equal to **P** PU'S  $\pm 0.02$  PU or  $\pm 5\%$ .

- c. Release the **TARGET RESET** button, then decrease the current. The **OUTPUT** LED will extinguish.
  - d. Press the **TARGET RESET** button to remove targets. This test may be repeated for testing the opposite winding or another phase.
5. **Slope 1 Test:**
- a. Define any number of testing points desirable to verify the trip  $I_A W_2$  (Input 2) curve.
  - b. Choose any values for  $I_A W_2$  (Input 2), and calculate the expected  $I_A$  (Input 1) according to the following:

$I_A W_1 - I_A W_2$	>	$(I_A W_1 + I_A W_2)$	x	S1/100	÷ 2
Difference in Currents	is greater than	sum of the currents	times	the per unit Slope1	divided by two.

Or

$$I_A W_1 = I_A W_2 \left[ \frac{(200 + S1)}{(200 - S1)} \right]$$

*S1 = slope in % from above.*

■ **NOTE:** The differential current  $I_A W_1 - I_A W_2$  must be greater than the minimum pickup current (**P**) and less than the Break Point (**BP**) value for proper operation. Select  $I_A W_2, \left( \frac{200-1}{2S1} \right) P < I_A W_2 < BP - \frac{P}{2}$

- c. Set  $I_A W_1$  (Input 1) and  $I_A W_2$  (Input 2) at the chosen value.
  - d. Press and hold the **TARGET RESET** button in, then slowly increase  $I_A W_2$  (Input 2) until the **PHASE DIFFERENTIAL 87T/H** LED illuminates, or the pickup indicator operates on the computer target screen. The level of operation will equal to (**P**) ±0.02 PU or ±5%.
  - e. Release the **TARGET RESET** button, then decrease the current. The **OUTPUT** LED will extinguish.
  - f. Press the **TARGET RESET** button to remove targets. This test may be repeated for testing the opposite winding or another phase.
7. **Slope 2 Test:**
- a. Define any number of testing points desirable to verify the trip  $I_A W_2$  (Input 2) current curve.
  - b. Choose any values for  $I_A W_2$  (Input 2) and calculate the expected  $I_A$  (Input 1) according to the following:

$$I_A W_1 = \frac{\left[ I_A W_2 \left( 1 + \frac{S2}{200} \right) + BP \left( \frac{S1-S2}{100} \right) \right]}{\left( 1 - \frac{S2}{200} \right)}$$

**S1** and **S2** = slope in % from above. The differential current,  $I_A W_1 - I_A W_2$  must be greater than both the minimum pickup current (**P**) and the **BP** values. Select  $I_A W_2 > (BP - \frac{P}{2})$

- c. Set  $I_A W_1$  (Input 1) and  $I_A W_2$  (Input 2) to the chosen value.
- d. Press and hold the **TARGET RESET** button, then slowly increase  $I_A W_1$  (Input 1) current until the **PHASE DIFFERENTIAL 87T/H** LED illuminates or the pickup indicator operates on the computer target screen. The level of operation should be equal to (**P**) PU ±0.02 PU or ±1%.
- e. Release the **TARGET RESET** button, then decrease the current. The **OUTPUT** LED will extinguish.
- f. Press the **TARGET RESET** button to remove targets. This test may be repeated for testing the opposite winding or another phase.

9. **Second Harmonic Restraint Test**
  - a. Ensure that Even Harmonic Restraint is enabled with the amplitude of  $I_A W_1$  (input 1) at 60 Hz (or 50 Hz) set to 10% above (**P**) PU setting and verify that the **PHASE DIFFERENTIAL 87T/H** LED illuminates.
  - b. Apply 0 Amps at 120 Hz (100 Hz for 50 Hz units) to  $I_A W_1$  (Input 1).
  - c. Press and hold the **TARGET RESET** button in, then slowly increase the amplitude of  $I_A W_1$  until the **PHASE DIFFERENTIAL 87T/H** LED extinguishes. This level will be (**E**) times (**P**) PU,  $\pm 1\%$ .
  
11. **Fourth Harmonic Restraint Test:**
  - a. Ensure that Even Harmonic Restraint is enabled with the amplitude of  $I_A W_1$  (Input 1) at 60 Hz (or 50 Hz) set to 10% above **P** PU setting and verify the **PHASE DIFFERENTIAL 87T/H** LED is illuminated.
  - b. Apply 0 Amps at 240 Hz (200 Hz for 50 Hz units) to  $I_A W_1$  (Input 1).
  - c. Press and hold the **TARGET RESET** button in, then slowly increase the amplitude of the 4<sup>th</sup> Harmonic current  $I_A W_1$  until the **PHASE DIFFERENTIAL 87T/H** LED extinguishes. This level will be (**E**) times (**P**) PU,  $\pm 1\%$ .
  
12. **Fifth Harmonic Restraint Test:**
  - a. Ensure that 5<sup>th</sup> Harmonic Restraint is enabled with the amplitude of  $I_A W_1$  (Input 1) at 60 Hz (or 50 Hz) set to above (**P**) PU, and below (**FP**) PU settings and verify the **PHASE DIFFERENTIAL 87T/H** LED is illuminated.
  - b. Apply (**P**) times (**F**) +10% Amps at 300 Hz (250 Hz for 50 Hz units) to  $I_A W_1$  (Input 1), and verify that the **PHASE DIFFERENTIAL 87T/H** LED extinguishes.
  - c. Press and hold the **TARGET RESET** button in, then slowly decrease the amplitude of the 5<sup>th</sup> Harmonic current  $I_A W_1$  until the **PHASE DIFFERENTIAL 87T/H** LED illuminates. This level will be (**F**) times (**P**) PU,  $\pm 1\%$ .
  
13. **Elevated Pickup at 5<sup>th</sup> Harmonic Restraint Test**
  - a. Ensure that 5<sup>th</sup> Harmonic Restraint is enabled with 60 Hz (or 50 Hz) set to 10% above (**FP**) PU, and verify that the **PHASE DIFFERENTIAL 87T/H** LED illuminates.
  - b. Apply (**P**) times (**F**) + 10% Amps at 300 Hz (250 Hz for 50 Hz units) to  $I_A W_1$  (Input 1), then verify that the **PHASE DIFFERENTIAL 87T/H** LED extinguishes.
  - c. Press and hold the **TARGET RESET** button, then slowly decrease the 60 Hz (or 50 Hz) amplitude of  $I_A W_1$  until the **PHASE DIFFERENTIAL 87T/H** LED extinguishes. This level will be (**FP**) PU,  $\pm 0.1$  PU or  $\pm 5\%$ .
  
14. If testing is complete, enable any functions disabled for this test. If further testing is desired, check the proper functions to disable for the next test and continue from this configuration.

**87GD Ground Differential (#1, #2)**

<b>VOLTAGE INPUTS:</b>	None			
<b>CURRENT INPUTS:</b>	As Described Below			
<b>TEST SETTINGS:</b>	87GD Pickup	P	Amps	(0.20 to 10.00)
	1 Amp CT Rating			(0.04 to 2.00)
	Time Delay	D	cycles	(1 to 8160)
	CT Ratio Correction			(0.10 to 7.99)
	Programmed Outputs	Z	OUT	(1 to 8)
		Expanded I/O		(9 to 16)
	Function 50G	Disable		
	Function 50N	Disable		
	Function 51G	Disable		
	Function 51N	Disable		

- Disable functions as shown. Refer to Section 4.2, **System Setpoints**, for procedure.
- Confirm settings to be tested. For testing purposes, it is recommended that the CT Ratio Corrections be set to 1.0. Otherwise, current values must be computed by using the following formulas:
  - $I_G W_2 = \text{Applied Current to Winding 2 } I_G W_2 \text{ divided by CT2.}$
  - $I_G W_3 = \text{Applied Current to Winding 3 } I_G W_3 \text{ divided by CT3.}$
  - $I_G W_4 = \text{Applied Current to Winding 3 } I_G W_4 \text{ divided by CT4.}$
- Non-Directional Pickup Test:**
  - Connect current input to  $I_G W_2$ , terminal numbers 50 and 51.
  - Press and hold the **TARGET RESET** button in, then slowly increase  $I_G$  until the **GROUND DIFFERENTIAL 87GD** LED illuminates or the pickup indicator operates on the computer target screen. The level at operation will be equal to (**P**) Amps  $\pm 0.1$  Amps or 5% ( $\pm 0.02$  Amp 1 A CT).
  - Release the **TARGET RESET** button, then decrease the current. The **OUTPUT** LED will extinguish.
  - Press **TARGET RESET** button to remove targets.
- Directional Pickup Test:**
  - Connect current input to  $I_G W_2$ , terminal numbers 50 and 51. Connect  $I_A W_2$ ,  $I_B$ , or  $I_C$  to current Input 1. Set  $I_G W_2$  to a magnitude equal to  $\frac{1}{2}$  (**P**) Amps.
  - Set  $I_A W_2$ ,  $I_B$ , or  $I_C$  to  $\angle 180^\circ$ , then slowly increase phase current until the **GROUND DIFFERENTIAL 87GD W2** LED illuminates or the pickup indicator operates on the computer screen. Operation will occur when the sum of  $I_G W_2$  and the applied phase current equal (**P**) Amps  $\pm 0.1$  Amps or  $\pm 5\%$  ( $\pm 0.02$  Amp 1 A CT).
  - Release the **TARGET RESET** button, then decrease the current. The **OUTPUT** LED will extinguish.
  - Reverse either current (currents now rephase) and re-test. The relay will not operate. The unit will operate regardless of the phase relationship if the phase current is reduced to 140 mAmps or less, and the difference in current between  $I_G W_2$  and phase current exceeds the pickup value.
- Time Test:** With output contacts connected to the timer, apply current at least 10% higher than (**P**) Amps and start timing while observing **GROUND DIFFERENTIAL 87GD** LED for pickup. The operating time will be (**D**) cycles within  $-1$  to  $+3$  cycles.
- Repeat Step 5 for  $I_G W_3$  and  $I_G W_4$  connecting current to terminals 58 and 59 ( $I_G W_3$ ) or 72 and 73 ( $I_G W_4$ ).
- If testing is complete, enable any functions disabled for this test. If further testing is desired, check the proper functions to disable for the next test and continue from this configuration.

## BM Breaker Monitoring

<b>VOLTAGE INPUTS:</b>	None		
<b>CURRENT INPUTS:</b>	As Described		
<b>TEST SETTINGS:</b>	Pickup	P	kAmps (kA <sup>2</sup> )* (0 to 50,000)
	Delay	D	Cycles (0.1 to 4095.9)
	Timing Method		(IT or I <sup>2</sup> T)
	Preset Accumulators		
	Phase A, B, or C		kAmp (kA <sup>2</sup> ) Cycles* (0 to 50,000)
	Programmed Outputs	Z	OUT (1 to 8)
	Blocking Inputs		(1 to 6)
		Expanded I/O	(7 to 8)
	Output Initiate		(1 to 8)
		Expanded I/O	(9 to 16)
	Input Initiate		(1 to 6)
		Expanded I/O	(7 to 8)

\* kA/kA cycles or kA<sup>2</sup>/kA<sup>2</sup> cycles is dependent on the Timing Method that is selected.

### Test Setup:

1. Determine the Breaker Monitoring Function settings to be tested (Input Initiate or Output Initiate).
2. Enter the Breaker Monitoring Function settings to be tested utilizing either the HMI or IPScom<sup>®</sup> Communications Software.
3. Connect a current input to I<sub>A</sub> terminals 38 and 39, I<sub>B</sub> terminals 40 and 41, and I<sub>C</sub> terminals 42 and 43.
4. Connect inputs for the polarization type selected for testing.

### Accumulator Test:

1. Apply a current value that considers Timing Method and Pickup Setting to current input I<sub>A</sub>.
2. Place a jumper between the designated input or output contact selected as initiate.
3. Utilizing either the HMI (Breaker Monitoring/Breaker Acc. Status) or IPScom Communications Software (Monitor/Metering II), verify that the Accumulator Status value for Phase A increments in D cycles ± 1 cycles or ± 1%.
4. Remove the jumper placed in Step 2.
5. Decrease applied I<sub>A</sub> current to 0 amps.
6. If desired, repeat test for I<sub>B</sub> and I<sub>C</sub>.

**Pickup Test:**

1. Apply a current value that considers Timing Method and Pickup Setting to current input  $I_A$ .

■ **NOTE:** If the target pickup setting is a large value (0 to 50,000) the Preset Accumulator Settings feature can be used to pre-set the accumulator values to just below the target setting.

2. Utilizing either the HMI (Breaker Monitoring/Breaker Acc. Status) or IPScm Communications Software (Monitor/Metering II) to monitor the accumulator value, place a jumper between the designated input or output contact selected as initiate and then remove the jumper.

Following the time out of the Delay the accumulator will increment, repeat the placement and removal of the jumper as necessary to increment the accumulator to a point where the pickup setting is exceeded.

3. When the accumulator value exceeds the pickup value the **OUTPUT** LED(s) will illuminate, or the function status indicator on the **Monitor Function Status** screen indicates that the function has picked up.

The output contacts **Z** will operate in **D** cycles  $\pm 1$  cycle or  $\pm 1\%$  from the last initiate.

4. If desired, repeat test for  $I_B$  and  $I_C$ .

## Trip Circuit Monitoring

<b>VOLTAGE INPUTS:</b>	As Described			
<b>CURRENT INPUTS:</b>	None			
<b>TEST SETTINGS:</b>	Delay	D	Cycles	(1 to 8160)
	Programmed Outputs	Z	OUT	(1 to 8)
		Expanded I/O		(9 to 16)

### Test Setup:

1. Determine the Trip Circuit Monitoring function settings to be tested.
2. Disable all other functions prior to testing. Refer to Section 4.2, **System Setpoints** for details that describe disabling/enabling functions.
3. Connect a DC voltage supply capable of supplying 24/48/125/250 V dc (marked on the rear of the relay) to terminals 1 (-) and 2 (+) on the relay.
4. Connect a timer to output contacts (**Z**) so that the timer stops timing when the contacts (**Z**) close.

### Pickup Test:

1. Apply the applicable DC voltage (24/48/125/250 V dc marked on the rear of the relay) to terminals 1 (-) and 2 (+).
2. Enable the Trip Circuit Monitoring function and then enter the settings to be tested utilizing either the HMI or IPScm Communications Software.
3. Remove the DC voltage applied in Step 1. The **OUTPUT** LED will illuminate, indicating that the Trip Circuit Monitoring function has actuated.

The contacts will close after **D** cycles within  $\pm 1$  cycle or 1%.

4. Simulate a 52b contact close by connecting a jumper between terminal 11 (INRTN) and terminal 10 (IN1) which. The **BRKR CLOSED** and **OUTPUT** LEDs on the front of the relay should extinguish.
5. Remove the jumper installed in Step 4.

The contacts will close after **D** cycles within  $\pm 1$  cycle or 1%.

## Through Fault

<b>VOLTAGE INPUTS:</b>	As Described		
<b>CURRENT INPUTS:</b>	None		
<b>TEST SETTINGS:</b>	Through Fault Current Threshold	5 Amps	(1.0-100.0)
	Pickup Operation Limit	5	(1-65535)
	Cumulative I <sup>2</sup> T	100k A <sup>2</sup> Cycles	(10-1000000)
	Time Delay	1 Cycles	(1-8160)
	Current Selection	(sum1, sum2, w1, w2, w3, w4)	

### ***Threshold and Cumulative I<sup>2</sup> T Limit Tests:***

1. Utilize the IPSCom Metering II screen to monitor the counters.
2. Use the System/ Through Fault / Clear command to reset any previous Cumulative Through Current readings.
3. Apply a balanced 4 Amp current to the Winding 1, then verify that counters are not incrementing.
4. Remove the applied current.
5. Press the **TARGET RESET** button to clear any previous target indication.
6. Apply a balanced 6 Amp current to the Winding 1, then verify that counters are now incrementing. Approximately 46 seconds after the current was applied the Target LED will illuminate and the HMI will display the Through Fault information.
7. Remove the applied current.

### ***Pickup Operation Limit Test***

1. Use the System/ Through Fault / Clear command to reset any previous Cumulative Through Current readings.
2. Press the **TARGET RESET** pushbutton to clear any previous target indication
3. Apply for approximately 2 seconds a balanced 6 Amp current, then remove the current. Repeat this step a second time and the Target LED will illuminate and the HMI will display the Through Fault information.
4. If testing is complete clear the through fault counters and disable the function.

**IPSlogic (#1-6)**

<b>VOLTAGE INPUTS:</b>	As required			
<b>CURRENT INPUTS:</b>	As required			
<b>TEST SETTINGS:</b>	Time Delay	D	Cycles	(1 to 65500)
	Reset/Dropout Delay	RD	Cycles	(0 to 65500)
	Programmed Outputs	Z	OUT	(1 to 8)
			Expanded I/O	(9 to 16)
	Blocking Inputs			(1 to 6)
	Output Initiate			(1 to 8)
	Function Initiate	(All Available Functions)		
	Initiate via Communication			
	Input Initiate			(1 to 8)
	Block via Communication			

1. Refer to Figure 4-48, IPSlogic, for logic gate configurations.
2. Select gate configuration (AND/OR) for Output Initiate, Function Initiate, Blocking Inputs and Inputs Main.
3. Select Initiating Inputs for each gate (if AND gate is selected, ensure at least two outputs are chosen). It will be necessary to enable and operate other functions to provide inputs for the Function Initiate and Output Initiate gates.
4. **Pickup Test:** With output contact(s) **Z** connected to the timer, apply inputs to gates and start timing. The operating time will be (**D**) cycles within -1 to +3 cycles or  $\pm 1\%$ , and the selected IPSlogic target LED and the **OUTPUT** LED will illuminate or the pickup indicator will operate on the computer target screen.
5. **Blocking Input Test:** To test the designated blocking inputs, press and hold the **TARGET RESET** button, then short input terminals designated as blocking inputs. The **IPS** LED will extinguish.
6. Repeat for each designated external triggering contact.
7. If testing is complete, enable any functions disabled for this test. If further testing is desired, check the proper functions to disable for the next test and continue from this configuration.

# A Appendix – Configuration Forms

This Appendix contains forms for photocopying, and recording the configuration and setting of the M-3311A Transformer Protection Relay, and to file the data for future reference. Examples of the suggested use of these forms are illustrated in Chapter 4, **System Setup and Setpoints** and Chapter 2, **Operation**.

Page A-2 contains a copy of the Relay Configuration Table and is herein provided to define and record the blocking inputs and output configuration for the relay. For each function, check if **DISABLED** or check the output contacts to be operated by the function. Also check the inputs designated to block the function operation.

The Communication Data & Unit Setup Record Form reproduces the Communication and Setup unit menus. This form records definition of the parameters necessary for communication with the relay, as well as access codes, user logo (identifying) lines, date & time setting, and front panel display operation.

The functional Configuration Record Form reproduces the Configure Relay menus including the Setup Relay submenu which is accessible via M-3826 IPScom® Communication Software or the optional M-3931 HMI front panel module.

For each function or setpoint, refer to the configuration you have defined using the Relay Configuration Table, and circle whether it should be enabled or disabled by the output contacts it will activate, and the inputs that will block its operation.

The Setpoint & Timing Record Form allows recording of the specific values entered for each enabled setpoint or function. The form follows the main menu selections of the relay.

The “**AS SHIPPED**” data forms illustrate the factory settings of the relay.

Examples:

```
81U#1 UNDERFREQUENCY
disable ENABLE
```

```
81U#1 BLOCK INPUT
i6 i5 i4 i3 i2 i1
```

```
81U#1 RELAY OUTPUT
o8 o7 o6 o5 o4 o3 o2 o1
```

FUNCTION	O U T P U T S								I N P U T S							
	D	8	7	6	5	4	3	2	1	6	5	4	3	2	1	
24 DEF TIME #1																
24 DEF TIME #2																
24 INV TIME																
27																
46 DEF TIME W2																
46 INV TIME W2																
46 DEF TIME W3																
46 INV TIME W3																
46 DEF TIME W4																
46 INV TIME W4																
49																
50 #1																
50 #2																
50 #3																
50 #4																
50 #5																
50 #6																
50 #7																
50 #8																
50BFW1																
50BFW2																
50BFW3																
50BFW4																
50GW2 #1																
50GW2 #2																
50GW3 #1																
50GW3 #2																
50GW4 #1																
50GW4 #2																
50N #1																
50N #2																
50N #3																
50N #4																
50N #5																
50N #6																
50N #7																
50N #8																

Table A-1 Relay Configuration (page 1 of 2)

FUNCTION	D O U T P U T S								I N P U T S							
	8	7	6	5	4	3	2	1	6	5	4	3	2	1		
51 #1																
51 #2																
51 #3																
51 #4																
51GW2																
51GW3																
51GW4																
51N #1																
51N #2																
51N #3																
51N #4																
59G #1																
59G #2																
81 #1																
81 #2																
81 #3																
81 #4																
87H																
87T																
87GDW2																
87GDW3																
87GDW4																
IPS #1																
IPS #2																
IPS #3																
IPS #4																
IPS #5																
IPS #6																
BM W1																
BM W2																
BM W3																
BM W4																
TCM																
TF																

Table A-1 Relay Configuration (page 2 of 2)

### KEY TO INPUT DATA RECORD FORMS

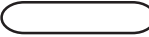
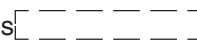
- A. All heavily bordered  screens are either MENU screens which have horizontal choices (made with right - left arrows) or screens displaying a result of a choice previously made.
- B. Dashed boxes  enclose screens which bound areas that pushbutton **ENTER** will move in. In order to move out of one of the dotted boxes it is necessary to either push **EXIT** or make a menu choice change using the Right - Left arrow.
- C. The Up/Down arrows only adjust value or letter (lower/upper case) inputs; they do not move within the menus or between menu displays.
- D. The Right/Left arrows are used only to make horizontally displayed choices. These can be either menu choices or input value digit choices. The previous choice or location in a menu is highlighted immediately.
- E. The **ENTER** pushbutton records the setting change (whatever is in that screen when ENTER is pressed will be installed in memory) and moves down *within* a menu. The operator will notice that after the last menu item, **ENTER** moves to the top of the same menu but does not change menu positions.
- F. Pressing **EXIT** at any time will exit the display screen to the last screen containing a horizontal choice. (Return to the preceding menu).

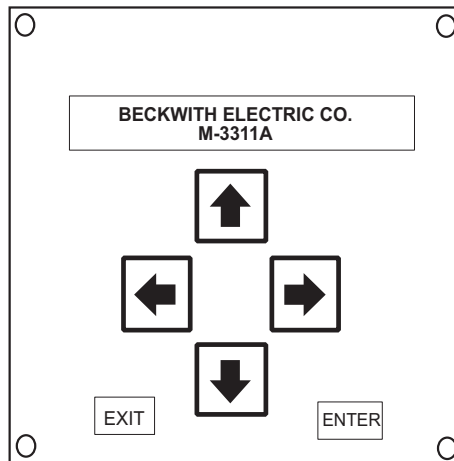

Figure A-1 M-3931 Human-Machine Interface Module

- G. The symbol → or ← in a screen indicates additional horizontal menu choices are available in the indicated direction. As previously described, the Right and Left arrows will move the operator to those additional choices.

CONFIGURE RELAY VOLTAGE_RELAY →	CONFIGURE RELAY ← CURRENT_RELAY →	CONFIGURE RELAY ← ext brkr CONFIG →
<p><b>27 PHASE UNDERVOLTAGE</b> disable enable</p> <p>27 BLOCK INPUT i6 i5 i4 i3 i2 i1</p> <p>27 RELAY OUTPUT o8 o7 o6 o5 o4 o3 o2 o1</p> <hr style="border-top: 1px dashed black;"/> <p><b>59G#1 GROUND OVERVOLTAGE</b> disable enable</p> <p>59G#1 BLOCK INPUT i6 i5 i4 i3 i2 i1</p> <p>59G#1 RELAY OUTPUT o8 o7 o6 o5 o4 o3 o2 o1</p> <p><b>59G#2 GROUND OVERVOLTAGE</b> disable enable</p> <p>59G#2 BLOCK INPUT i6 i5 i4 i3 i2 i1</p> <p>59G#2 RELAY OUTPUT o8 o7 o6 o5 o4 o3 o2 o1</p>	<p><b>46DTW2 DEF TIME NSEQ O/C</b> disable enable</p> <p>46DTW2 BLOCK INPUT i6 i5 i4 i3 i2 i1</p> <p>46DTW2 RELAY OUTPUT o8 o7 o6 o5 o4 o3 o2 o1</p> <p><b>46ITW2 INV TIME NSEQ O/C</b> disable enable</p> <p>46ITW2 BLOCK INPUT i6 i5 i4 i3 i2 i1</p> <p>46ITW2 RELAY OUTPUT o8 o7 o6 o5 o4 o3 o2 o1</p> <p><b>46DTW3 DEF TIME NSEQ O/C</b> disable enable</p> <p>46DTW3 BLOCK INPUT i6 i5 i4 i3 i2 i1</p> <p>46DTW3 RELAY OUTPUT o8 o7 o6 o5 o4 o3 o2 o1</p>	<p><b>46ITW3 INV TIME NSEQ O/C</b> disable enable</p> <p>46ITW3 BLOCK INPUT i6 i5 i4 i3 i2 i1</p> <p>46ITW3 RELAY OUTPUT o8 o7 o6 o5 o4 o3 o2 o1</p> <p><b>46DTW4 DEF TIME NSEQ O/C</b> disable enable</p> <p>46DTW4 BLOCK INPUT i6 i5 i4 i3 i2 i1</p> <p>46DTW4 RELAY OUTPUT o8 o7 o6 o5 o4 o3 o2 o1</p> <p><b>46ITW4 INV TIME NSEQ O/C</b> disable enable</p> <p>46ITW4 BLOCK INPUT i6 i5 i4 i3 i2 i1</p> <p>46ITW4 RELAY OUTPUT o8 o7 o6 o5 o4 o3 o2 o1</p>
		<p><b>49 THERMAL PROTECTION</b> disable enable</p> <p>49 BLOCK INPUT i6 i5 i4 i3 i2 i1</p> <p>49 RELAY OUTPUT o8 o7 o6 o5 o4 o3 o2 o1</p>

Figure A-2 Functional Configuration Record Form (Page 1 of 9)

CONFIGURE RELAY  
 ← ext brkr CONFIG →

<b>50#1 INST PHASE O/C</b> disable enable  50#1 BLOCK INPUT i6 i5 i4 i3 i2 i1  50#1 RELAY OUTPUT o8 o7 o6 o5 o4 o3 o2 o1	<b>50#5 INST PHASE O/C</b> disable enable  50#5 BLOCK INPUT i6 i5 i4 i3 i2 i1  50#5 RELAY OUTPUT o8 o7 o6 o5 o4 o3 o2 o1	<b>51#1 INV TIME O/C</b> disable enable  51#1 BLOCK INPUT i6 i5 i4 i3 i2 i1  51#1 RELAY OUTPUT o8 o7 o6 o5 o4 o3 o2 o1
<b>50#2 INST PHASE O/C</b> disable enable  50#2 BLOCK INPUT i6 i5 i4 i3 i2 i1  50#2 RELAY OUTPUT o8 o7 o6 o5 o4 o3 o2 o1	<b>50#6 INST PHASE O/C</b> disable enable  50#6 BLOCK INPUT i6 i5 i4 i3 i2 i1  50#6 RELAY OUTPUT o8 o7 o6 o5 o4 o3 o2 o1	<b>51#2 INV TIME O/C</b> disable enable  51#2 BLOCK INPUT i6 i5 i4 i3 i2 i1  51#2 RELAY OUTPUT o8 o7 o6 o5 o4 o3 o2 o1
<b>50#3 INST PHASE O/C</b> disable enable  50#3 BLOCK INPUT i6 i5 i4 i3 i2 i1  50#3 RELAY OUTPUT o8 o7 o6 o5 o4 o3 o2 o1	<b>50#7 INST PHASE O/C</b> disable enable  50#7 BLOCK INPUT i6 i5 i4 i3 i2 i1  50#7 RELAY OUTPUT o8 o7 o6 o5 o4 o3 o2 o1	<b>51#3 INV TIME O/C</b> disable enable  51#3 BLOCK INPUT i6 i5 i4 i3 i2 i1  51#3 RELAY OUTPUT o8 o7 o6 o5 o4 o3 o2 o1
<b>50#4 INST PHASE O/C</b> disable enable  50#4 BLOCK INPUT i6 i5 i4 i3 i2 i1  50#4 RELAY OUTPUT o8 o7 o6 o5 o4 o3 o2 o1	<b>50#8 INST PHASE O/C</b> disable enable  50#8 BLOCK INPUT i6 i5 i4 i3 i2 i1  50#8 RELAY OUTPUT o8 o7 o6 o5 o4 o3 o2 o1	<b>51#4 INV TIME O/C</b> disable enable  51#4 BLOCK INPUT i6 i5 i4 i3 i2 i1  51#4 RELAY OUTPUT o8 o7 o6 o5 o4 o3 o2 o1

Figure A-2 Functional Configuration Record Form (Page 2 of 9)

CONFIGURE RELAY  
 ← ext brkr CONFIG →

<b>50GW2#1 INST GROUND O/C</b> disable enable  50GW2#1 BLOCK INPUT i6 i5 i4 i3 i2 i1  50GW2#1 RELAY OUTPUT o8 o7 o6 o5 o4 o3 o2 o1	<b>50GW4#2 INST GROUND O/C</b> disable enable  50GW4#2 BLOCK INPUT i6 i5 i4 i3 i2 i1  50GW4#2 RELAY OUTPUT o8 o7 o6 o5 o4 o3 o2 o1
<b>50GW2#2 INST GROUND O/C</b> disable enable  50GW2#2 BLOCK INPUT i6 i5 i4 i3 i2 i1  50GW2#2 RELAY OUTPUT o8 o7 o6 o5 o4 o3 o2 o1	<b>51GW2 INV TIME GND O/C</b> disable enable  51GW2 BLOCK INPUT i6 i5 i4 i3 i2 i1  51GW2 RELAY OUTPUT o8 o7 o6 o5 o4 o3 o2 o1
<b>50GW3#1 INST GROUND O/C</b> disable enable  50GW3#1 BLOCK INPUT i6 i5 i4 i3 i2 i1  50GW3#1 RELAY OUTPUT o8 o7 o6 o5 o4 o3 o2 o1	<b>51GW3 INV TIME GND O/C</b> disable enable  51GW3 BLOCK INPUT i6 i5 i4 i3 i2 i1  51GW3 RELAY OUTPUT o8 o7 o6 o5 o4 o3 o2 o1
<b>50GW3#2 INST GROUND O/C</b> disable enable  50GW3#2 BLOCK INPUT i6 i5 i4 i3 i2 i1  50GW3#2 RELAY OUTPUT o8 o7 o6 o5 o4 o3 o2 o1	<b>51GW4 INV TIME GND O/C</b> disable enable  51GW4 BLOCK INPUT i6 i5 i4 i3 i2 i1  51GW4 RELAY OUTPUT o8 o7 o6 o5 o4 o3 o2 o1
<b>50GW4#1 INST GROUND O/C</b> disable enable  50GW4#1 BLOCK INPUT i6 i5 i4 i3 i2 i1  50GW4#1 RELAY OUTPUT o8 o7 o6 o5 o4 o3 o2 o1	

Figure A-2 Functional Configuration Record Form (Page 3 of 9)

CONFIGURE RELAY  
 ← ext brkr CONFIG →

<b>50N#1 INST RESID O/C</b> disable enable	<b>50N#5 INST RESID O/C</b> disable enable
50N#1 BLOCK INPUT i6 i5 i4 i3 i2 i1	50N#5 BLOCK INPUT i6 i5 i4 i3 i2 i1
50N#1 RELAY OUTPUT o8 o7 o6 o5 o4 o3 o2 o1	50N#5 RELAY OUTPUT o8 o7 o6 o5 o4 o3 o2 o1
<b>50N#2 INST RESID O/C</b> disable enable	<b>50N#6 INST RESID O/C</b> disable enable
50N#2 BLOCK INPUT i6 i5 i4 i3 i2 i1	50N#6 BLOCK INPUT i6 i5 i4 i3 i2 i1
50N#2 RELAY OUTPUT o8 o7 o6 o5 o4 o3 o2 o1	50N#6 RELAY OUTPUT o8 o7 o6 o5 o4 o3 o2 o1
<b>50N#3 INST RESID O/C</b> disable enable	<b>50N#7 INST RESID O/C</b> disable enable
50N#3 BLOCK INPUT i6 i5 i4 i3 i2 i1	50N#7 BLOCK INPUT i6 i5 i4 i3 i2 i1
50N#3 RELAY OUTPUT o8 o7 o6 o5 o4 o3 o2 o1	50N#7 RELAY OUTPUT o8 o7 o6 o5 o4 o3 o2 o1
<b>50N#4 INST RESID O/C</b> disable enable	<b>50N#8 INST RESID O/C</b> disable enable
50N#4 BLOCK INPUT i6 i5 i4 i3 i2 i1	50N#8 BLOCK INPUT i6 i5 i4 i3 i2 i1
50N#4 RELAY OUTPUT o8 o7 o6 o5 o4 o3 o2 o1	50N#8 RELAY OUTPUT o8 o7 o6 o5 o4 o3 o2 o1

Figure A-2 Functional Configuration Record Form (Page 4 of 9)

CONFIGURE RELAY  
 ← ext brkr CONFIG →

<b>51N#1 INV TIME RESID O/C</b> disable enable  51N#1 BLOCK INPUT i6 i5 i4 i3 i2 i1  51N#1 RELAY OUTPUT o8 o7 o6 o5 o4 o3 o2 o1	<b>87H HI SET DIFFERENTIAL</b> disable enable  87H BLOCK INPUT i6 i5 i4 i3 i2 i1  87H RELAY OUTPUT o8 o7 o6 o5 o4 o3 o2 o1
<b>51N#2 INV TIME RESID O/C</b> disable enable  51N#2 BLOCK INPUT i6 i5 i4 i3 i2 i1  51N#2 RELAY OUTPUT o8 o7 o6 o5 o4 o3 o2 o1	<b>87T DIFFERENTIAL CURRENT</b> disable enable  87T BLOCK INPUT i6 i5 i4 i3 i2 i1  87T RELAY OUTPUT o8 o7 o6 o5 o4 o3 o2 o1
<b>51N#3 INV TIME RESID O/C</b> disable enable  51N#3 BLOCK INPUT i6 i5 i4 i3 i2 i1  51N#3 RELAY OUTPUT o8 o7 o6 o5 o4 o3 o2 o1	
<b>51N#4 INV TIME RESID O/C</b> disable enable  51N#4 BLOCK INPUT i6 i5 i4 i3 i2 i1  51N#4 RELAY OUTPUT o8 o7 o6 o5 o4 o3 o2 o1	

Figure A-2 Functional Configuration Record Form (Page 5 of 9)

CONFIGURE RELAY  
 ← ext brkr CONFIG →

<b>87GDW2#1 GND DIFF</b> disable enable	<b>87GDW3#2 GND DIFF</b> disable enable	<b>50BFW1 BREAKER FAILURE</b> disable enable
87GDW2#1 BLOCK INPUT i6 i5 i4 i3 i2 i1	87GDW3#2 BLOCK INPUT i6 i5 i4 i3 i2 i1	50BFW1 BLOCK INPUT i6 i5 i4 i3 i2 i1
87GDW2#1 RELAY OUTPUT o8 o7 o6 o5 o4 o3 o2 o1	87GDW3#2 RELAY OUTPUT o8 o7 o6 o5 o4 o3 o2 o1	50BFW1 RELAY OUTPUT o8 o7 o6 o5 o4 o3 o2 o1
<b>87GDW2#2 GND DIFF</b> disable enable	<b>87GDW4#1 GND DIFF</b> disable enable	<b>50BFW2 BREAKER FAILURE</b> disable enable
87GDW2#2 BLOCK INPUT i6 i5 i4 i3 i2 i1	87GDW4#1 BLOCK INPUT i6 i5 i4 i3 i2 i1	50BFW2 BLOCK INPUT i6 i5 i4 i3 i2 i1
87GDW2#2 RELAY OUTPUT o8 o7 o6 o5 o4 o3 o2 o1	87GDW4#1 RELAY OUTPUT o8 o7 o6 o5 o4 o3 o2 o1	50BFW2 RELAY OUTPUT o8 o7 o6 o5 o4 o3 o2 o1
<b>87GDW3#1 GND DIFF</b> disable enable	<b>87GDW4#2 GND DIFF</b> disable enable	<b>50BFW3 BREAKER FAILURE</b> disable enable
87GDW3#1 BLOCK INPUT i6 i5 i4 i3 i2 i1	87GDW4#2 BLOCK INPUT i6 i5 i4 i3 i2 i1	50BFW3 BLOCK INPUT i6 i5 i4 i3 i2 i1
87GDW3#1 RELAY OUTPUT o8 o7 o6 o5 o4 o3 o2 o1	87GDW4#2 RELAY OUTPUT o8 o7 o6 o5 o4 o3 o2 o1	50BFW3 RELAY OUTPUT o8 o7 o6 o5 o4 o3 o2 o1
		<b>50BFW4 BREAKER FAILURE</b> disable enable
		50BFW4 BLOCK INPUT i6 i5 i4 i3 i2 i1
		50BFW4 RELAY OUTPUT o8 o7 o6 o5 o4 o3 o2 o1

Figure A-2 Functional Configuration Record Form (Page 6 of 9)

CONFIGURE RELAY  
 ← ext brkr CONFIG →

CONFIGURE RELAY ← FREQUENCY_RELAY →	CONFIGURE RELAY ←VOLTS_PER_HZ_RELAY→
<p><b>81#1 FREQUENCY</b> disable enable</p> <p>81#1 BLOCK INPUT i6 i5 i4 i3 i2 i1</p> <p>81#1 RELAY OUTPUT o8 o7 o6 o5 o4 o3 o2 o1</p> <p><b>81#2 FREQUENCY</b> disable enable</p> <p>81#2 BLOCK INPUT i6 i5 i4 i3 i2 i1</p> <p>81#2 RELAY OUTPUT o8 o7 o6 o5 o4 o3 o2 o1</p> <p><b>81#3 FREQUENCY</b> disable enable</p> <p>81#3 BLOCK INPUT i6 i5 i4 i3 i2 i1</p> <p>81#3 RELAY OUTPUT o8 o7 o6 o5 o4 o3 o2 o1</p> <p><b>81#4 FREQUENCY</b> disable enable</p> <p>81#4 BLOCK INPUT i6 i5 i4 i3 i2 i1</p> <p>81#4 RELAY OUTPUT o8 o7 o6 o5 o4 o3 o2 o1</p>	<p><b>24DT#1 DEF TIME VOLTS/HZ</b> disable enable</p> <p>24DT#1 BLOCK INPUT i6 i5 i4 i3 i2 i1</p> <p>24DT#1 RELAY OUTPUT o8 o7 o6 o5 o4 o3 o2 o1</p> <p><b>24DT#2 DEF TIME VOLTS/HZ</b> disable enable</p> <p>24DT#2 BLOCK INPUT i6 i5 i4 i3 i2 i1</p> <p>24DT#2 RELAY OUTPUT o8 o7 o6 o5 o4 o3 o2</p> <p><b>24IT INV TIME VOLTS/HZ</b> disable enable</p> <p>24IT BLOCK INPUT i6 i5 i4 i3 i2 i1</p> <p>24IT RELAY OUTPUT o8 o7 o6 o5 o4 o3 o2 o1</p>

Figure A-2 Functional Configuration Record Form (Page 7 of 9)

CONFIGURE RELAY ← ext brkr CONFIG →		
CONFIGURE RELAY ← IPS LOGIC →		CONFIGURE RELAY ← BREAKER_MONITOR
<p><b>IPS#1 IPS LOGIC</b> disable enable</p> <p>IPS#1 BLOCK INPUT i6 i5 i4 i3 i2 i1</p> <p>IPS#1 RELAY OUTPUT o8 o7 o6 o5 o4 o3 o2 o1</p>	<p><b>IPS#4 IPS LOGIC</b> disable enable</p> <p>IPS#4 BLOCK INPUT i6 i5 i4 i3 i2 i1</p> <p>IPS#4 RELAY OUTPUT o8 o7 o6 o5 o4 o3 o2 o1</p>	<p><b>BRKRW1 BREAKER MONITOR</b> disable enable</p> <p>BRKRW1 BLOCK INPUT i6 i5 i4 i3 i2 i1</p> <p>BRKRW1 RELAY OUTPUT o8 o7 o6 o5 o4 o3 o2 o1</p>
<p><b>IPS#2 IPS LOGIC</b> disable enable</p> <p>IPS#2 BLOCK INPUT i6 i5 i4 i3 i2 i1</p> <p>IPS#2 RELAY OUTPUT o8 o7 o6 o5 o4 o3 o2 o1</p>	<p><b>IPS#5 IPS LOGIC</b> disable enable</p> <p>IPS#5 BLOCK INPUT i6 i5 i4 i3 i2 i1</p> <p>IPS#5 RELAY OUTPUT o8 o7 o6 o5 o4 o3 o2 o1</p>	<p><b>BRKRW2 BREAKER MONITOR</b> disable enable</p> <p>BRKRW2 BLOCK INPUT i6 i5 i4 i3 i2 i1</p> <p>BRKRW2 RELAY OUTPUT o8 o7 o6 o5 o4 o3 o2 o1</p>
<p><b>IPS#3 IPS LOGIC</b> disable enable</p> <p>IPS#3 BLOCK INPUT i6 i5 i4 i3 i2 i1</p> <p>IPS#3 RELAY OUTPUT o8 o7 o6 o5 o4 o3 o2 o1</p>	<p><b>IPS#6 IPS LOGIC</b> disable enable</p> <p>IPS#6 BLOCK INPUT i6 i5 i4 i3 i2 i1</p> <p>IPS#6 RELAY OUTPUT o8 o7 o6 o5 o4 o3 o2 o1</p>	<p><b>BRKRW3 BREAKER MONITOR</b> disable enable</p> <p>BRKRW3 BLOCK INPUT i6 i5 i4 i3 i2 i1</p> <p>BRKRW3 RELAY OUTPUT o8 o7 o6 o5 o4 o3 o2 o1</p>
		<p><b>BRKRW4 BREAKER MONITOR</b> disable enable</p> <p>BRKRW4 BLOCK INPUT i6 i5 i4 i3 i2 i1</p> <p>BRKRW4 RELAY OUTPUT o8 o7 o6 o5 o4 o3 o2 o1</p>

Figure A-2 Functional Configuration Record Form (Page 8 of 9)

CONFIGURE RELAY ← ext brkr CONFIG →	
CONFIGURE RELAY ← THROUGH FAULT →	CONFIGURE RELAY ← TCM MONITOR →
<b>THFLT THROUGH FAULT</b> disable enable  THFLT BLOCK INPUT i6 i5 i4 i3 i2 i1  THFLT RELAY OUTPUT o8 o7 o6 o5 o4 o3 o2 o1	<b>TCM TRIP CKT MONITOR</b> disable enable  TCM BLOCK INPUT i6 i5 i4 i3 i2 i1  TCM RELAY OUTPUT o8 o7 o6 o5 o4 o3 o2 o1

Figure A-2 Functional Configuration Record Form (Page 9 of 9)

SETUP SYSTEM ← config SYS stat dmd →		
<b>INPUT ACTIVATED PROFILES</b> IN ap cpy volt vt →  INPUT ACTIVATED PROFILES disable enable	W1 INCLUDE IN WIN SUM no yes  W2 INCLUDE IN WIN SUM no yes	W1 ZERO SEQ COMP disable enable  W2 ZERO SEQ COMP disable enable
<b>ACTIVE SETPOINT PROFILE</b> in AP cpy volt vt →  ACTIVE SETPOINT PROFILE _____	W3 INCLUDE IN WIN SUM no yes  W4 INCLUDE IN WIN SUM no yes	W3 ZERO SEQ COMP disable enable  W4 ZERO SEQ COMP disable enable
<b>COPY ACTIVE PROFILE</b> in ap CPY volt vt →  COPY ACTIVE PROFILE TO_PROFILE_1 →  COPY ACTIVE PROFILE TO_PROFILE_2 →  COPY ACTIVE PROFILE TO_PROFILE_3 →  COPY ACTIVE PROFILE TO_PROFILE_4 →	<b>CUSTOM XFM/CT CONNECTION</b> ← CONN phase seal in →  CUSTOM XFM/CT CONNECTION disable enable  W1 XFM PHASE COMP TYPE <u>0</u>  W2 XFM PHASE COMP TYPE <u>0</u>  W3 XFM PHASE COMP TYPE <u>0</u>  W4 XFM PHASE COMP TYPE <u>0</u>	
<b>NOMINAL VOLTAGE</b> in ap cpy VOLT vt →  NOMINAL VOLTAGE _____ Volts	W1 CT PH/MAG COMP TYPE <u>0</u>  W2 CT PH/MAG COMP TYPE <u>0</u>  W3 CT PH/MAG COMP TYPE <u>0</u>	
<b>V.T. CONFIGURATION</b> in ap cpy volt VT →  V.T. CONFIGURATION vab vbc vca va vb vc	W4 CT PH/MAG COMP TYPE <u>0</u>	
<b>NUMBER OF WINDINGS</b> ← NUM_OF_WINDINGS →  NUMBER OF WINDINGS three four		
<b>WINDING SUMMING</b> ← num_of_windings SUM →		

Figure A-3 Unit Setup and Communication Data Record Form (Page 1 of 5)

<div style="border: 1px solid black; border-radius: 10px; padding: 5px; display: inline-block;">                     SETUP SYSTEM                      ← config SYS stat dmd →                 </div>		
<b>CT CONNECTION W1</b> ←CON_W1 XFm_W1 con_w2→	<b>CT CONNECTION W3</b> ←XFm_w2 CON_W3 XFm_W3→	<b>RELAY SEAL-IN TIME</b> ← conn phase SEAL in →  RELAY SEAL-IN TIME OUT1 _____ Cycles  RELAY SEAL-IN TIME OUT2 _____ Cycles  RELAY SEAL-IN TIME OUT3 _____ Cycles  RELAY SEAL-IN TIME OUT4 _____ Cycles  RELAY SEAL-IN TIME OUT5 _____ Cycles  RELAY SEAL-IN TIME OUT6 _____ Cycles  RELAY SEAL-IN TIME OUT7 _____ Cycles  RELAY SEAL-IN TIME OUT8 _____ Cycles  RELAY SEAL-IN TIME OUT9 _____ Cycles  RELAY SEAL-IN TIME OUT10 _____ Cycles  RELAY SEAL-IN TIME OUT11 _____ Cycles  RELAY SEAL-IN TIME OUT12 _____ Cycles  RELAY SEAL-IN TIME OUT13 _____ Cycles  RELAY SEAL-IN TIME OUT14 _____ Cycles  RELAY SEAL-IN TIME OUT15 _____ Cycles  RELAY SEAL-IN TIME OUT16 _____ Cycles
<b>CT CONNECTION W1</b> Y dab dac inv_y → ← inv_dab inv_dac	<b>CT CONNECTION W3</b> Y dab dac inv_y → ← inv_dab inv_dac	
<b>XFM CONNECTION W1</b> ←CON_W1 XFM_W1 CON_W2→	<b>XFM CONNECTION W3</b> ←XFM_W2 CON_w3 XFM_W3→	
<b>XFM CONNECTION W1</b> Y dab dac inv_y → ← inv_dab inv_dac	<b>XFM CONNECTION W3</b> Y dab dac inv_y → ← inv_dab inv_dac	
<b>CT CONNECTION W2</b> ←con_w1 XFm_W1 CON_W2→	<b>CT CONNECTION W4</b> ←XFm_w3 CON_W4 XFm_W4→	
<b>CT CONNECTION W2</b> Y dab dac inv_y → ← inv_dab inv_dac	<b>CT CONNECTION W4</b> Y dab dac inv_y → ← inv_dab inv_dac	
<b>XFM CONNECTION W2</b> ←XFM_W2 CON_W3 xfm_w3→	<b>XFM CONNECTION W4</b> ←XFM_W3 CON_w4 XFM_W4→	
<b>XFM CONNECTION W2</b> Y dab dac inv_y → ← inv_dab inv_dac	<b>XFM CONNECTION W4</b> Y dab dac inv_y → ← inv_dab inv_dac	
<b>PHASE ROTATION</b> ← conn PHASE seal in →  PHASE ROTATION a_c_b    a_b_c		

Figure A-3 Unit Setup and Communication Data Record Form (Page 2 of 5)

SETUP SYSTEM ← config SYS stat dmd →	
<p><b>ACTIVE INPUT STATE</b> ←conn phase seal IN→</p> <p>ACTIVE INPUT OPEN/CLOSE i6 i5 i4 i3 i2 <u>i</u>1</p> <p><b>V.T.x RATIO</b> ←VTX vtg ct_w1 ct_w2→</p> <p>V.T.x RATIO _____ :1</p> <p><b>V.T.g RATIO</b> ←vtx VTG ct_w1 ct_w2→</p> <p>V.T.g RATIO _____ :1</p> <p><b>W1 C.T. RATIO</b> ←vtx vts CT_W1 ct_w2→</p> <p>W1 C.T. RATIO _____ :1</p> <p><b>W2 C.T. RATIO</b> ←vtx vts ct_W1 CT_w2→</p> <p>W2 C.T. RATIO _____ :1</p>	<p><b>W2 C.T. GROUND RATIO</b> ←CT_w2G ct_w3 ct_w3g→</p> <p>W2 C.T. GROUND RATIO _____ :1</p> <p><b>W3 C.T. RATIO</b> ←ct_W1 ct_w2 CT_w3→</p> <p>W3 C.T. RATIO _____ :1</p> <p><b>W3 C.T. GROUND RATIO</b> ← CT_W3G ct_w3 CT_W3G →</p> <p>W3 C.T. GROUND RATIO _____ :1</p> <p><b>W4 C.T. RATIO</b> ←ct_W4 ct_w4g→</p> <p>W4 C.T. RATIO _____ :1</p> <p><b>W4 C.T. GROUND RATIO</b> ← ct_w4g CT_W4G →</p> <p>W4 C.T. GROUND RATIO _____ :1</p>

Figure A-3 Unit Setup and Communication Data Record Form (Page 3 of 5)

COMMUNICATION	
← targets osc_rec COMM→	
<p><b>COM1 SETUP</b> com1 com2 com3 com_adr→</p> <p>COM1 BAUD RATE ← BAUD_300 BAUD_600 → ←BAUD 1200 BAUD_2400→ ←baud_4800 baud_9600</p> <p><b>COM2 SETUP</b> com1 COM2 com3 com_adr→</p> <p>COM2 BAUD RATE ←BAUD_300 BAUD_600→ ←BAUD 1200 BAUD_2400→ ←baud 4800 baud_9600</p> <p>COM2 DEAD SYNC TIME _____ms</p> <p>COM2 PROTOCOL beco2200 modbus dnp3</p> <p><b>COM3 SETUP</b> com1 com2 COM3 com_adr→</p> <p>COM3 DEAD SYNC TIME _____ms</p> <p>COM3 PROTOCOL beco2200 modbus dnp3</p> <p><b>COMMUNICATION ADDRESS</b> com1 com2 com3 COM_ADR→</p> <p>COMMUNICATION ADDRESS _____</p> <p><b>RESPONSE TIME DELAY</b> DLY access eth eth_ip</p> <p>RESPONSE TIME DELAY _____ms</p> <p><b>COMM ACCESS CODE</b> ← dly ACCESS eth eth_ip</p> <p>COMM ACCESS CODE _____</p>	<p><b>ETHERNET SETUP</b> ← dly accss ETH eth_ip</p> <p>ETHERNET disable ENABLE</p> <p>TCP/IP SETTINGS TCP prot</p> <p>SELECT PROTOCOL MODBUS SERCONV</p> <p>DHCP PROTOCOL disable ENABLE</p> <p>DHCP PROTOCOL DISABLE enable</p> <p>IP ADDRESS _____</p> <p>NET MASK _____</p> <p>GATEWAY _____</p> <p>ETHERNET PROTOCOL tcp PROT</p> <p>SELECT PROTOCOL modbus serconv</p> <p><b>ETHERNET ADDRESS</b> ← accss eth ETH_IP</p> <p>ETHERNET IP ADDRESS XX.XX.XX.XX</p> <p>After Exit to Comm menu, the following will be displayed (if any changes have been made in ethernet menu)</p> <p>CONFIGURING ETH...</p> <p>ETHERNET IP ADDRESS XX.XX.XX.XX</p>

Figure A-3 Unit Setup Communication Data & Record Form (Page 4 of 5)

<div style="border: 1px solid black; border-radius: 15px; padding: 5px; display: inline-block;">                     SETUP UNIT                      ← SETUP                 </div>		
<p><b>SOFTWARE VERSION</b> VERS sn access number→</p> <p>SOFTWARE VERSION D-0179VXX.XX.XX XXXX</p> <p><b>SERIAL NUMBER</b> vers SN access number→</p> <p>SERIAL NUMBER _____</p> <p><b>ALTER ACCESS CODES</b> vers sn ACCESS number→</p> <p>ENTER ACCESS CODE LEVEL#1 level#2 level#3</p> <p>LEVEL #1 _____</p> <p>ENTER ACCESS CODE level#1 LEVEL#2 level#3</p> <p>LEVEL #2 _____</p> <p>ENTER ACCESS CODE level#1 level#2 LEVEL#3</p> <p>LEVEL #3 _____</p>	<p><b>USER CONTROL NUMBER</b> vers sn access NUMBER→</p> <p>USER CONTROL NUMBER _____</p> <p><b>USER LOGO LINE 1</b> ←LOGO1 logo2 out alrm→</p> <p>USER LOGO LINE 1 _____</p> <p><b>USER LOGO LINE 2</b> ←logo1 LOGO2 out alrm</p> <p>USER LOGO LINE 2 _____</p> <p><b>CLEAR OUTPUT COUNTERS</b> ←logo1 logo2 OUT alrm→</p> <p>CLEAR OUTPUT COUNTERS PRESS ENTER KEY TO CLEAR</p> <p><b>CLEAR ALARM COUNTER</b> ←logo1 logo2 out ALRM→</p> <p>CLEAR ALARM COUNTER PRESS ENTER KEY TO CLEAR</p>	<p><b>DATE &amp; TIME</b> ← TIME error diag</p> <p>DATE &amp; TIME 03-JAN-1998 01:00:80</p> <p>DATE &amp; TIME _____ Year</p> <p>DATE &amp; TIME jan feb mar apr may →</p> <p>DATE &amp; TIME _____ Date</p> <p>DATE &amp; TIME sun mon tue wed thu →</p> <p>DATE &amp; TIME _____ Hour</p> <p>DATE &amp; TIME _____ Minutes</p> <p>DATE &amp; TIME Seconds</p> <p><b>CLEAR ERROR CODES</b> ← time ERROR diag</p> <p>CLEAR ERROR CODES PRESS ENTER KEY TO CLEAR</p> <p><b>DIAGNOSTIC MODE</b> ← time error DIAG</p> <p>PROCESSOR WILL RESET ENTER KEY TO CONTINUE</p>

Figure A-3 Unit Setup Communication Data & Record Form (Page 5 of 5)

VOLTAGE RELAY  
VOLT curr freq v/hz →

<p><b>27 PHASE UNDERVOLTAGE</b> VOLT_UNDER g_over</p> <p>27 PICKUP _____ Volts</p> <p>27 INHIBIT disable enable</p> <p>27 INHIBIT _____ Volts</p> <p>27 DELAY _____ Cycles</p> <p><b>59G GROUND OVERVOLTAGE</b> volt_under G_OVER</p> <p>59G#1 PICKUP _____ Volts</p> <p>59G#1 DELAY _____ Cycles</p> <p>59G#2 PICKUP _____ Volts</p> <p>59G#2 DELAY _____ Cycles</p>	<p><b>46 NEGSEQ OVERCURRENT</b> NEG_SEQ therm inst →</p> <p>46DTW2 PICKUP _____ Amps</p> <p>46DTW2 DELAY _____ Cycles</p> <p>46ITW2 PICKUP _____ Amps</p> <p>46ITW2 CURVE BEDEF beinv bevinv beeinv→ ←ieci iecvi iecei ieclti→ ←ieemi ieevi ieeei</p> <p>46ITW2 TIME DIAL _____</p> <p>46DTW3 PICKUP _____ Amps</p> <p>46DTW3 DELAY _____ Cycles</p> <p>46ITW3 PICKUP _____ Amps</p> <p>46ITW3 CURVE BEDEF beinv bevinv beeinv→ ←ieci iecvi iecei ieclti→ ←ieemi ieevi ieeei</p>	<p>46ITW3 TIME DIAL _____</p> <p>46DTW4 PICKUP _____ Amps</p> <p>46DTW4 DELAY _____ Cycles</p> <p>46ITW4 PICKUP _____ Amps</p> <p>46ITW4 CURVE BEDEF beinv bevinv beeinv→ ←ieci iecvi iecei ieclti→ ←ieemi ieevi ieeei</p> <p>46ITW4 TIME DIAL _____</p> <p><b>49 WINDING THERM. PROT</b> neg_seq THERM inst →</p> <p>49 TIME CONSTANT _____ Min</p> <p>49 MAX OVERLOAD CURR. _____ Amps</p> <p>49 CURRENT SELECTION sum1 sum2 w1 w2 w3 w4</p>
---	--	--

Figure A-4 Setpoint & Timing Record Form (Page 1 of 14)

VOLTAGE RELAY  
 VOLT curr freq v/hz →

<b>50 INST OVERCURRENT</b> neg_seq therm INST	50#3 DELAY _____ Cycles	50#6 CURRENT SELECTION sum1 sum2 w1 w2 w3 w4
50#1 PICKUP _____ Amps	50#4 PICKUP _____ Amps	50#6 DELAY _____ Cycles
50#1 CURRENT SELECTION sum1 sum2 w1 w2 w3 w4	50#4 CURRENT SELECTION sum1 sum2 w1 w2 w3 w4	50#7 PICKUP _____ Amps
50#1 DELAY _____ Cycles	50#4 DELAY _____ Cycles	50#7 CURRENT SELECTION sum1 sum2 w1 w2 w3 w4
50#2 PICKUP _____ Amps	50#5 PICKUP _____ Amps	50#7 DELAY _____ Cycles
50#2 CURRENT SELECTION sum1 sum2 w1 w2 w3 w4	50#5 CURRENT SELECTION sum1 sum2 w1 w2 w3 w4	50#8 PICKUP _____ Amps
50#2 DELAY _____ Cycles	50#5 DELAY _____ Cycles	50#8 CURRENT SELECTION sum1 sum2 w1 w2 w3 w4
50#3 PICKUP _____ Amps	50#6 PICKUP _____ Amps	50#8 DELAY _____ Cycles
50#3 CURRENT SELECTION sum1 sum2 w1 w2 w3 w4		

Figure A-4 Setpoint & Timing Record Form (Page 2 of 14)

51 INV TIME OVERCURRENT ← INV g_inst g_inv →	50G INST GND OVERCURRENT ← inv G_INST g_inv →	51G INV TIME GND O/C ← inv g_inst G_INV →
51#1 PICKUP _____ Amps	50GW2#1 PICKUP _____ Amps	51GW2 PICKUP _____ Amps
51#1 CURVE BEDEF beinv bevinv beeinv→ ←ieci iecvi iecel iecclti→ ←ieemi ieevi ieeei	50GW2#1 DELAY _____ Cycles	51GW2 CURVE BEDEF beinv bevinv beeinv→ ←ieci iecvi iecel iecclti→ ←ieemi ieevi ieeei
51#1 TIME DIAL _____	50GW2#2 PICKUP _____ Amps	51GW2 TIME DIAL _____
51#1 CURRENT SELECTION sum1 sum2 w1 w2 w3 w4	50GW2#2 DELAY _____ Cycles	51GW3 PICKUP _____ Amps
51#2 PICKUP _____ Amps	50GW3#1 PICKUP _____ Amps	51GW3 CURVE BEDEF beinv bevinv beeinv→ ←ieci iecvi iecel iecclti→ ←ieemi ieevi ieeei
51#2 CURVE BEDEF beinv bevinv beeinv→ ←ieci iecvi iecel iecclti→ ←ieemi ieevi ieeei	50GW3#1 DELAY _____ Cycles	51GW3 TIME DIAL _____
51#2 TIME DIAL _____	50GW3#2 PICKUP _____ Amps	51GW4 PICKUP _____ Amps
51#2 CURRENT SELECTION sum1 sum2 w1 w2 w3 w4	50GW3#2 DELAY _____ Cycles	51GW4 CURVE BEDEF beinv bevinv beeinv→ ←ieci iecvi iecel iecclti→ ←ieemi ieevi ieeei
51#3 PICKUP _____ Amps	50GW4#1 PICKUP _____ Amps	51GW4 TIME DIAL _____
51#3 CURVE BEDEF beinv bevinv beeinv→ ←ieci iecvi iecel iecclti→ ←ieemi ieevi ieeei	50GW4#1 DELAY _____ Cycles	
51#3 TIME DIAL _____	50GW4#2 PICKUP _____ Amps	
51#3 CURRENT SELECTION sum1 sum2 w1 w2 w3 w4	50GW4#2 DELAY _____ Cycles	
51#4 CURVE BEDEF beinv bevinv beeinv→ ←ieci iecvi iecel iecclti→ ←ieemi ieevi ieeei		
51#4 TIME DIAL _____		
51#4 CURRENT SELECTION sum1 sum2 w1 w2 w3 w4		

Figure A-4 Setpoint & Timing Record Form (Page 3 of 14)

50N INST RESIDUAL O/C  
← R\_INST r\_inv diff →

50N#1 PICKUP _____ Amps	50N#5 PICKUP _____ Amps
50N#1 CURRENT SELECTION sum1 sum2 w1 w2 w3 w4	50N#5 CURRENT SELECTION sum1 sum2 w1 w2 w3 w4
50N#1 DELAY _____ Cycles	50N#5 DELAY _____ Cycles
50N#2 PICKUP _____ Amps	50N#6 PICKUP _____ Amps
50N#2 CURRENT SELECTION sum1 sum2 w1 w2 w3 w4	50N#6 CURRENT SELECTION sum1 sum2 w1 w2 w3 w4
50N#2 DELAY _____ Cycles	50N#6 DELAY _____ Cycles
50N#3 PICKUP _____ Amps	50N#7 PICKUP _____ Amps
50N#3 CURRENT SELECTION sum1 sum2 w1 w2 w3 w4	50N#7 CURRENT SELECTION sum1 sum2 w1 w2 w3 w4
50N#3 DELAY _____ Cycles	50N#7 DELAY _____ Cycles
50N#4 PICKUP _____ Amps	50N#8 PICKUP _____ Amps
50N#4 CURRENT SELECTION sum1 sum2 w1 w2 w3 w4	50N#8 CURRENT SELECTION sum1 sum2 w1 w2 w3 w4
50N#4 DELAY _____ Cycles	50N#8 DELAY _____ Cycles

Figure A-4 Setpoint & Timing Record Form (Page 4 of 14)

51 INV TIME OVERCURRENT  
 ← inv g\_inst g\_inv →

50G INST GND OVERCURRENT  
 ← inv G\_INST g\_inv →

51#1 PICKUP _____ Amps	51#3 PICKUP _____ Amps
51#1 CURVE BEDEF beinv bevinv beeinv→ ←ieci iecvi iecei ieclti→ ←ieemi ieevi ieeei	51#3 CURVE BEDEF beinv bevinv beeinv→ ←ieci iecvi iecei ieclti→ ←ieemi ieevi ieeei
51#1 TIME DIAL _____	51#3 TIME DIAL _____
51#1 CURRENT SELECTION sum1 sum2 w1 w2 w3 w4	51#3 CURRENT SELECTION sum1 sum2 w1 w2 w3 w4
51#2 PICKUP _____ Amps	51#4 PICKUP _____ Amps
51#2 CURVE BEDEF beinv bevinv beeinv→ ←ieci iecvi iecei ieclti→ ←ieemi ieevi ieeei	51#4 CURVE BEDEF beinv bevinv beeinv→ ←ieci iecvi iecei ieclti→ ←ieemi ieevi ieeei
51#2 TIME DIAL _____	51#4 TIME DIAL _____
51#2 CURRENT SELECTION sum1 sum2 w1 w2 w3 w4	51#4 CURRENT SELECTION sum1 sum2 w1 w2 w3 w4

50GW2#1 PICKUP _____ Amps
50GW2#1 DELAY _____ Cycles
50GW2#2 PICKUP _____ Amps
50GW2#2 DELAY _____ Cycles
50GW3#1 PICKUP _____ Amps
50GW3#1 DELAY _____ Cycles
50GW3#2 PICKUP _____ Amps
50GW3#2 DELAY _____ Cycles
50GW4#1 PICKUP _____ Amps
50GW4#1 DELAY _____ Cycles
50GW4#2 PICKUP _____ Amps
50GW4#2 DELAY _____ Cycles

Figure A-4 Setpoint & Timing Record Form (Page 5 of 14)

51G INV TIME GND O/C  
 ← inv g\_inst G\_INV →

50N INST RESIDUAL O/C  
 ← R\_INST r\_inv diff →

51GW2 PICKUP  
 \_\_\_\_\_ Amps

51GW2 CURVE  
 BEDEF beinv bevinv beeinv→  
 ←ieci iecvi iecel iecclti→  
 ←ieemi ieevi ieeei

51GW2 TIME DIAL  
 \_\_\_\_\_

51GW3 PICKUP  
 \_\_\_\_\_ Amps

51GW3 CURVE  
 BEDEF beinv bevinv beeinv→  
 ←ieci iecvi iecel iecclti→  
 ←ieemi ieevi ieeei

51GW3 TIME DIAL  
 \_\_\_\_\_

51GW4 PICKUP  
 \_\_\_\_\_ Amps

51GW4 CURVE  
 BEDEF beinv bevinv beeinv→  
 ←ieci iecvi iecel iecclti→  
 ←ieemi ieevi ieeei

51GW4 TIME DIAL  
 \_\_\_\_\_

50N#1 PICKUP _____ Amps	50N#5 PICKUP _____ Amps
50N#1 CURRENT SELECTION sum1 sum2 w1 w2 w3 w4	50N#5 CURRENT SELECTION sum1 sum2 w1 w2 w3 w4
50N#1 DELAY _____ Cycles	50N#5 DELAY _____ Cycles
50N#2 PICKUP _____ Amps	50N#6 PICKUP _____ Amps
50N#2 CURRENT SELECTION sum1 sum2 w1 w2 w3 w4	50N#6 CURRENT SELECTION sum1 sum2 w1 w2 w3 w4
50N#2 DELAY _____ Cycles	50N#6 DELAY _____ Cycles
50N#3 PICKUP _____ Amps	50N#7 PICKUP _____ Amps
50N#3 CURRENT SELECTION sum1 sum2 w1 w2 w3 w4	50N#7 CURRENT SELECTION sum1 sum2 w1 w2 w3 w4
50N#3 DELAY _____ Cycles	50N#7 DELAY _____ Cycles
50N#4 PICKUP _____ Amps	50N#8 PICKUP _____ Amps
50N#4 CURRENT SELECTION sum1 sum2 w1 w2 w3 w4	50N#8 CURRENT SELECTION sum1 sum2 w1 w2 w3 w4
50N#4 DELAY _____ Cycles	50N#8 DELAY _____ Cycles

Figure A-4 Setpoint & Timing Record Form (Page 6 of 14)

51N INV TIME RESID. O/C  
 ← r\_inst R\_INV diff →

87 DIFFERENTIAL OVERCURP  
 ← r\_inst r\_inv DIFF

51N#1 PICKUP _____ Amps	51N#3 PICKUP _____ Amps
51N#1 CURVE BEDEF beinv bevinv beeinv→ ←ieci iecvi iecei ieclti→ ←ieemi ieevi ieeei	51N#3 CURVE BEDEF beinv bevinv beeinv→ ←ieci iecvi iecei ieclti→ ←ieemi ieevi ieeei
51N#1 TIME DIAL _____	51N#3 TIME DIAL _____
50N#1 CURRENT SELECTION sum1 sum2 w1 w2 w3 w4	50N#3 CURRENT SELECTION sum1 sum2 w1 w2 w3 w4
51N#2 PICKUP _____ Amps	51N#4 PICKUP _____ Amps
51N#2 CURVE BEDEF beinv bevinv beeinv→ ←ieci iecvi iecei ieclti→ ←ieemi ieevi ieeei	51N#4 CURVE BEDEF beinv bevinv beeinv→ ←ieci iecvi iecei ieclti→ ←ieemi ieevi ieeei
51N#2 TIME DIAL _____	51N#4 TIME DIAL _____
51N#2 CURRENT SELECTION sum1 sum2 w1 w2 w3 w4	51N#4 CURRENT SELECTION sum1 sum2 w1 w2 w3 w4

87H PICKUP _____ PU
87H DELAY _____ Cycles
87T PICKUP _____ PU
87T SLOPE #1 _____ %
87T SLOPE #2 _____ %
87T SLOPE BREAKPOINT _____ PU
87T EVEN RESTRAINT disable enable cross_avg
87T EVEN RESTRAINT _____ %
87T 5TH RESTRAINT disable enable cross_avg
87T 5TH RESTRAINT _____ %
87T PICKUP @5TH RESTRAIN _____ PU
87 W1 C.T. TAP _____
87 W2 C.T. TAP _____
87 W3 C.T. TAP _____
87 W4 C.T. TAP _____

Figure A-4 Setpoint & Timing Record Form (Page 7 of 14)

87GD GND DIFF OVERCURR  
 ← G\_DIFF brk\_fail

87GDW2#1 PICKUP _____ Amps	87GDW4#1 PICKUP _____ Amps
87GDW2#1 DELAY _____ Cycles	87GDW4#1 DELAY _____ Cycles
87GDW2#2 PICKUP _____ Amps	87GDW4#2 PICKUP _____ Amps
87GDW2#2 DELAY _____ Cycles	87GDW4#2 DELAY _____ Cycles
87GDW2 C.T. RATIO CORR. _____	87GDW4 C.T. RATIO CORR. _____
87GDW2 DIR ELEMENT disable enable	87GDW4 DIR ELEMENT disable enable
87GDW2 CURRENT SELECTION SNGL_win sum1 sum2	87GDW4 CURRENT SELECTION SNGL_win sum1 sum2
87GDW3#1 PICKUP _____ Amps	
87GDW3#1 DELAY _____ Cycles	
87GDW3#2 PICKUP _____ Amps	
87GDW3#2 DELAY _____ Cycles	
87GDW3 C.T. RATIO CORR. _____	
87GDW3 DIR ELEMENT disable enable	
87GDW3 CURRENT SELECTION SNGL_win sum1 sum2	

Figure A-4 Setpoint & Timing Record Form (Page 8 of 14)

50BF BREAKER FAILURE ← g_diff BRK_FAIL		FREQUENCY RELAY volt curr FREQ v/hz →	
50BFW1 PICKUP RESIDUAL _____ Amps	50BFW3 PICKUP RESIDUAL _____ Amps	81U OVER/UNDER FREQUENCY FREQ	
50BFW1 PICKUP PHASE _____ Amps	50BFW3 PICKUP PHASE _____ Amps	81#1 PICKUP _____ Hz	
50BFW1 INPUT INITIATE i6 i5 i4 i3 i2 i1	50BFW3 INPUT INITIATE i6 i5 i4 i3 i2 i1	81#1 DELAY _____ Cycles	
50BFW1 OUTPUT INITIATE o8 o7 o6 o5 o4 o3 o2 o1	50BFW3 OUTPUT INITIATE o8 o7 o6 o5 o4 o3 o2 o1	81#2 PICKUP _____ Hz	
50BFW1 DELAY _____ Cycles	50BFW3 DELAY _____ Cycles	81#2 DELAY _____ Cycles	
50BFW2 PICKUP RESIDUAL _____ Amps	50BFW4 PICKUP RESIDUAL _____ Amps	81#3 PICKUP _____ Hz	
50BFW2 PICKUP PHASE _____ Amps	50BFW4 PICKUP PHASE _____ Amps	81#3 DELAY _____ Cycles	
50BFW2 INPUT INITIATE i6 i5 i4 i3 i2 i1	50BFW4 INPUT INITIATE i6 i5 i4 i3 i2 i1	81#4 PICKUP _____ Hz	
50BFW2 OUTPUT INITIATE o8 o7 o6 o5 o4 o3 o2 o1	50BFW4 OUTPUT INITIATE o8 o7 o6 o5 o4 o3 o2 o1	81#4 DELAY _____ Cycles	
50BFW2 DELAY _____ Cycles	50BFW4 DELAY _____ Cycles		

Figure A-4 Setpoint & Timing Record Form (Page 9 of 14)

VOLTS PER HERTZ RELAY volt curr freq V/HZ →	24 INV TIME VOLTS/HERTZ def_v/hz INV_V/HZ
<p>24 DEF TIME VOLTS/HERTZ DEF_V/HZ inv_v/hz</p> <p>24DT#1 PICKUP _____ %</p> <p>24DT#1 DELAY _____ Cycles</p> <p>24DT#2 PICKUP _____ %</p> <p>24DT#2 DELAY _____ Cycles</p>	<p>24IT PICKUP _____ %</p> <p>24IT CURVE crv#1 crv#2 crv#3 crv#4</p> <p>24IT TIME DIAL _____</p> <p>24IT RESET RATE _____ Seconds</p>

Figure A-4 Setpoint & Timing Record Form (Page 10 of 14)

IPS LOGIC  
 IPS brkr thflt tcm →

IPS LOGIC  
 IPS

IPS#1 INPUT INITIATE i6 i5 i4 i3 i2 i1	IPS#4 INPUT INITIATE i6 i5 i4 i3 i2 i1
IPS#1 OUTPUT INITIATE o8 o7 o6 o5 o4 o3 o2 o1	IPS#4 OUTPUT INITIATE o8 o7 o6 o5 o4 o3 o2 o1
IPS#1 DELAY _____ Cycles	IPS#4 DELAY _____ Cycles
IPS#2 INPUT INITIATE i6 i5 i4 i3 i2 i1	IPS#5 INPUT INITIATE i6 i5 i4 i3 i2 i1
IPS#2 OUTPUT INITIATE o8 o7 o6 o5 o4 o3 o2 o1	IPS#5 OUTPUT INITIATE o8 o7 o6 o5 o4 o3 o2 o1
IPS#2 DELAY _____ Cycles	IPS#5 DELAY _____ Cycles
IPS#3 INPUT INITIATE i6 i5 i4 i3 i2 i1	IPS#6 INPUT INITIATE i6 i5 i4 i3 i2 i1
IPS#3 OUTPUT INITIATE o8 o7 o6 o5 o4 o3 o2 o1	IPS#6 OUTPUT INITIATE o8 o7 o6 o5 o4 o3 o2 o1
IPS#3 DELAY _____ Cycles	IPS#6 DELAY _____ Cycles

Figure A-4 Setpoint & Timing Record Form (Page 11 of 14)

BREAKER MONITORING  
← ips BRKR thflt tcm →

BREAKER ACC. STATUS  
brkr STAT prst clr

<p><b>SET BREAKER MONITORING</b> BRKR stat prst clr</p>	<p>BRKRW3 PICKUP _____ kA-cycles</p>	<p>W1 ACCUMULATOR A= 0 A-cycles</p>
<p>BRKRW1 PICKUP _____ kA-cycles</p>	<p>BRKRW3 INPUT INITIATE i6 i5 i4 i3 i2 i1</p>	<p>W1 ACCUMULATOR B= 0 A-cycles</p>
<p>BRKRW1 INPUT INITIATE i6 i5 i4 i3 i2 i1</p>	<p>BRKRW3 OUTPUT INITIATE o8 o7 o6 o5 o4 o3 o2 o1</p>	<p>W1 ACCUMULATOR C= 0 A-cycles</p>
<p>BRKRW1 OUTPUT INITIATE o8 o7 o6 o5 o4 o3 o2 o1</p>	<p>BRKRW3 DELAY _____ Cycles</p>	<p>W2 ACCUMULATOR A= 0 A-cycles</p>
<p>BRKRW1 DELAY _____ Cycles</p>	<p>BRKRW3 TIMING METHOD it i2t</p>	<p>W2 ACCUMULATOR B= 0 A-cycles</p>
<p>BRKRW1 TIMING METHOD it i2t</p>	<p>BRKRW4 PICKUP _____ kA-cycles</p>	<p>W2 ACCUMULATOR C= 0 A-cycles</p>
<p>BRKRW2 PICKUP _____ kA-cycles</p>	<p>BRKRW4 INPUT INITIATE i6 i5 i4 i3 i2 i1</p>	<p>W3 ACCUMULATOR A= 0 A-cycles</p>
<p>BRKRW2 INPUT INITIATE i6 i5 i4 i3 i2 i1</p>	<p>BRKRW4 OUTPUT INITIATE o8 o7 o6 o5 o4 o3 o2 o1</p>	<p>W3 ACCUMULATOR B= 0 A-cycles</p>
<p>BRKRW2 OUTPUT INITIATE o8 o7 o6 o5 o4 o3 o2 o1</p>	<p>BRKRW4 DELAY _____ Cycles</p>	<p>W3 ACCUMULATOR C= 0 A-cycles</p>
<p>BRKRW2 DELAY _____ Cycles</p>	<p>BRKRW4 TIMING METHOD it i2t</p>	<p>W4 ACCUMULATOR A= 0 A-cycles</p>
<p>BRKRW2 TIMING METHOD it i2t</p>		<p>W4 ACCUMULATOR B= 0 A-cycles</p>
		<p>W4 ACCUMULATOR C= 0 A-cycles</p>

Figure A-4 Setpoint & Timing Record Form (Page 12 of 14)

PRESET ACCUMULATORS brkr stat PRST clr		CLEAR ACCUMULATORS brkr stat prst CLR	
ACC. A W1 SET A_W1 b_w1 c_w1 →	ACC. A W3 SET ←A_W3 b_w3 c_w3	ACC. A W1 CLEAR A_W1 b_w1 c_w1 →	
BRKR. ACCUMULATOR kA-cycles	BRKR. ACCUMULATOR _____ kA-cycles	ACC. B W1 CLEAR a_w1 B_W1 c_w1 →	
ACC. B W1 SET a_w1 B_W1 c_w1 →	ACC. B W3 SET ←a_w3 B_W3 c_w3	ACC. C W1 CLEAR a_w1 b_w1 C_W1 →	
BRKR. ACCUMULATOR _____ kA-cycles	BRKR. ACCUMULATOR _____ kA-cycles	ACC. A W2 CLEAR fA_W2 b_w2 c_w2→	
ACC. C W1 SET a_w1 b_w1 C_W1 →	ACC. C W3 SET ←a_w3 b_w3 C_W3	ACC B W2 CLEAR fa_w2 B_W2 c_w2→	
BRKR. ACCUMULATOR _____ kA-cycles	BRKR. ACCUMULATOR _____ kA-cycles	ACC C W2 CLEAR fa_w2 b_w2 C_W2→	
ACC. A W2 SET ←A_W2 b_w2 c_w2 →	ACC. A W4 SET ←A_W4 b_w4 c_w4	ACC A W3 CLEAR fA_W3 b_w3 c_w3→	
BRKR. ACCUMULATOR _____ kA-cycles	BRKR. ACCUMULATOR _____ kA-cycles	ACC B W3 CLEAR fa_w3 B_W3 c_w3→	
ACC. B W2 SET ←a_w2 B_W2 c_w2 →	ACC. B W4 SET ←a_w4 B_W4 c_w4	ACC C W3 CLEAR fa_w3 b_w3 C_W3→	
BRKR. ACCUMULATOR _____ kA-cycles	BRKR. ACCUMULATOR _____ kA-cycles	ACC A W4 CLEAR fA_W4 b_w4 c_w4	
ACC. C W2 SET ←a_w2 b_w2 C_W2 →	ACC. C W4 SET ←a_w4 b_w4 C_W4	ACC B W4 CLEAR fa_w4 B_W4 c_w4	
BRKR. ACCUMULATOR _____ kA-cycles	BRKR. ACCUMULATOR _____ kA-cycles	ACC C W4 CLEAR fa_w4 b_w4 C_W4	

Figure A-4 Setpoint & Timing Record Form (Page 13 of 14)

THROUGH FAULT ←ips brkr THFLT tcm →	
THFLT CURRENT THRESHOLD _____ Amps	
THFLT CUM. I <sup>2</sup> T LIMIT _____ kA <sup>2</sup> -cycles	
THFLT PU OPERATIONS LIM. _____ Records	
THFLT WINDING SELECT win1 win2 win3 win4	
THFLT DELAY _____ Cycles	
TRIP CIRCUIT MONITORING ←ips brkr thflt TCM→	
TCM DELAY _____ Cycles	

Figure A-4 Setpoint & Timing Record Form (Page 14 of 14)

CONFIGURE RELAY VOLTAGE_RELAY →	CONFIGURE RELAY ← CURRENT_RELAY →	CONFIGURE RELAY ← ext brkr CONFIG →
<p><b>27 PHASE UNDERVOLTAGE</b> DISABLE enable</p> <p>27 BLOCK INPUT i6 i5 i4 i3 i2 i1</p> <p>27 RELAY OUTPUT o8 o7 o6 o5 o4 o3 o2 o1</p> <hr style="border-top: 1px dashed black;"/> <p><b>59G#1 GROUND OVERVOLTAGE</b> DISABLE enable</p> <p>59G#1 BLOCK INPUT i6 i5 i4 i3 i2 i1</p> <p>59G#1 RELAY OUTPUT o8 o7 o6 o5 o4 o3 o2 o1</p> <p><b>59G#2 GROUND OVERVOLTAGE</b> DISABLE enable</p> <p>59G#2 BLOCK INPUT i6 i5 i4 i3 i2 i1</p> <p>59G#2 RELAY OUTPUT o8 o7 o6 o5 o4 o3 o2 o1</p>	<p><b>46DTW2 DEF TIME NSEQ O/C</b> DISABLE enable</p> <p>46DTW2 BLOCK INPUT i6 i5 i4 i3 i2 i1</p> <p>46DTW2 RELAY OUTPUT o8 o7 o6 o5 o4 o3 o2 o1</p> <p><b>46ITW2 INV TIME NSEQ O/C</b> DISABLE enable</p> <p>46ITW2 BLOCK INPUT i6 i5 i4 i3 i2 i1</p> <p>46ITW2 RELAY OUTPUT o8 o7 o6 o5 o4 o3 o2 o1</p> <p><b>46DTW3 DEF TIME NSEQ O/C</b> DISABLE enable</p> <p>46DTW3 BLOCK INPUT i6 i5 i4 i3 i2 i1</p> <p>46DTW3 RELAY OUTPUT o8 o7 o6 o5 o4 o3 o2 o1</p>	<p><b>46ITW3 INV TIME NSEQ O/C</b> DISABLE enable</p> <p>46ITW3 BLOCK INPUT i6 i5 i4 i3 i2 i1</p> <p>46ITW3 RELAY OUTPUT o8 o7 o6 o5 o4 o3 o2 o1</p> <p><b>46DTW4 DEF TIME NSEQ O/C</b> DISABLE enable</p> <p>46DTW4 BLOCK INPUT i6 i5 i4 i3 i2 i1</p> <p>46DTW4 RELAY OUTPUT o8 o7 o6 o5 o4 o3 o2 o1</p> <p><b>46ITW4 INV TIME NSEQ O/C</b> DISABLE enable</p> <p>46ITW4 BLOCK INPUT i6 i5 i4 i3 i2 i1</p> <p>46ITW4 RELAY OUTPUT o8 o7 o6 o5 o4 o3 o2 o1</p>
		<p><b>49 THERMAL PROTECTION</b> DISABLE enable</p> <p>49 BLOCK INPUT i6 i5 i4 i3 i2 i1</p> <p>49 RELAY OUTPUT o8 o7 o6 o5 o4 o3 o2 o1</p>

Figure A-5 Functional Configuration Record Form As Shipped (Page 1 of 9)

CONFIGURE RELAY  
 ← ext brkr CONFIG →

<p><b>50#1 INST PHASE O/C</b> DISABLE enable</p> <p>50#1 BLOCK INPUT i6 i5 i4 i3 i2 i1</p> <p>50#1 RELAY OUTPUT o8 o7 o6 o5 o4 o3 o2 o1</p>	<p><b>50#5 INST PHASE O/C</b> DISABLE enable</p> <p>50#5 BLOCK INPUT i6 i5 i4 i3 i2 i1</p> <p>50#5 RELAY OUTPUT o8 o7 o6 o5 o4 o3 o2 o1</p>	<p><b>51#1 INV TIME O/C</b> DISABLE enable</p> <p>51#1 BLOCK INPUT i6 i5 i4 i3 i2 i1</p> <p>51#1 RELAY OUTPUT o8 o7 o6 o5 o4 o3 o2 o1</p>
<p><b>50#2 INST PHASE O/C</b> DISABLE enable</p> <p>50#2 BLOCK INPUT i6 i5 i4 i3 i2 i1</p> <p>50#2 RELAY OUTPUT o8 o7 o6 o5 o4 o3 o2 o1</p>	<p><b>50#6 INST PHASE O/C</b> DISABLE enable</p> <p>50#6 BLOCK INPUT i6 i5 i4 i3 i2 i1</p> <p>50#6 RELAY OUTPUT o8 o7 o6 o5 o4 o3 o2 o1</p>	<p><b>51#2 INV TIME O/C</b> DISABLE enable</p> <p>51#2 BLOCK INPUT i6 i5 i4 i3 i2 i1</p> <p>51#2 RELAY OUTPUT o8 o7 o6 o5 o4 o3 o2 o1</p>
<p><b>50#3 INST PHASE O/C</b> DISABLE enable</p> <p>50#3 BLOCK INPUT i6 i5 i4 i3 i2 i1</p> <p>50#3 RELAY OUTPUT o8 o7 o6 o5 o4 o3 o2 o1</p>	<p><b>50#7 INST PHASE O/C</b> DISABLE enable</p> <p>50#7 BLOCK INPUT i6 i5 i4 i3 i2 i1</p> <p>50#7 RELAY OUTPUT o8 o7 o6 o5 o4 o3 o2 o1</p>	<p><b>51#3 INV TIME O/C</b> DISABLE enable</p> <p>51#3 BLOCK INPUT i6 i5 i4 i3 i2 i1</p> <p>51#3 RELAY OUTPUT o8 o7 o6 o5 o4 o3 o2 o1</p>
<p><b>50#4 INST PHASE O/C</b> DISABLE enable</p> <p>50#4 BLOCK INPUT i6 i5 i4 i3 i2 i1</p> <p>50#4 RELAY OUTPUT o8 o7 o6 o5 o4 o3 o2 o1</p>	<p><b>50#8 INST PHASE O/C</b> DISABLE enable</p> <p>50#8 BLOCK INPUT i6 i5 i4 i3 i2 i1</p> <p>50#8 RELAY OUTPUT o8 o7 o6 o5 o4 o3 o2 o1</p>	<p><b>51#4 INV TIME O/C</b> DISABLE enable</p> <p>51#4 BLOCK INPUT i6 i5 i4 i3 i2 i1</p> <p>51#4 RELAY OUTPUT o8 o7 o6 o5 o4 o3 o2 o1</p>

Figure A-5 Functional Configuration Record Form As Shipped (Page 2 of 9)

CONFIGURE RELAY  
 ← ext brkr CONFIG →

<b>50GW2#1 INST GROUND O/C</b> DISABLE enable  50GW2#1 BLOCK INPUT i6 i5 i4 i3 i2 i1  50GW2#1 RELAY OUTPUT o8 o7 o6 o5 o4 o3 o2 o1	<b>50GW4#2 INST GROUND O/C</b> DISABLE enable  50GW4#2 BLOCK INPUT i6 i5 i4 i3 i2 i1  50GW4#2 RELAY OUTPUT o8 o7 o6 o5 o4 o3 o2 o1
<b>50GW2#2 INST GROUND O/C</b> DISABLE enable  50GW2#2 BLOCK INPUT i6 i5 i4 i3 i2 i1  50GW2#2 RELAY OUTPUT o8 o7 o6 o5 o4 o3 o2 o1	<b>51GW2 INV TIME GND O/C</b> DISABLE enable  51GW2 BLOCK INPUT i6 i5 i4 i3 i2 i1  51GW2 RELAY OUTPUT o8 o7 o6 o5 o4 o3 o2 o1
<b>50GW3#1 INST GROUND O/C</b> DISABLE enable  50GW3#1 BLOCK INPUT i6 i5 i4 i3 i2 i1  50GW3#1 RELAY OUTPUT o8 o7 o6 o5 o4 o3 o2 o1	<b>51GW3 INV TIME GND O/C</b> DISABLE enable  51GW3 BLOCK INPUT i6 i5 i4 i3 i2 i1  51GW3 RELAY OUTPUT o8 o7 o6 o5 o4 o3 o2 o1
<b>50GW3#2 INST GROUND O/C</b> DISABLE enable  50GW3#2 BLOCK INPUT i6 i5 i4 i3 i2 i1  50GW3#2 RELAY OUTPUT o8 o7 o6 o5 o4 o3 o2 o1	<b>51GW4 INV TIME GND O/C</b> DISABLE enable  51GW4 BLOCK INPUT i6 i5 i4 i3 i2 i1  51GW4 RELAY OUTPUT o8 o7 o6 o5 o4 o3 o2 o1
<b>50GW4#1 INST GROUND O/C</b> DISABLE enable  50GW4#1 BLOCK INPUT i6 i5 i4 i3 i2 i1  50GW4#1 RELAY OUTPUT o8 o7 o6 o5 o4 o3 o2 o1	

Figure A-5 Functional Configuration Record Form As Shipped (Page 3 of 9)

CONFIGURE RELAY  
 ← ext brkr CONFIG →

<b>50N#1 INST RESID O/C</b> DISABLE enable	<b>50N#5 INST RESID O/C</b> DISABLE enable
50N#1 BLOCK INPUT i6 i5 i4 i3 i2 i1	50N#5 BLOCK INPUT i6 i5 i4 i3 i2 i1
50N#1 RELAY OUTPUT o8 o7 o6 o5 o4 o3 o2 o1	50N#5 RELAY OUTPUT o8 o7 o6 o5 o4 o3 o2 o1
<b>50N#2 INST RESID O/C</b> DISABLE enable	<b>50N#6 INST RESID O/C</b> DISABLE enable
50N#2 BLOCK INPUT i6 i5 i4 i3 i2 i1	50N#6 BLOCK INPUT i6 i5 i4 i3 i2 i1
50N#2 RELAY OUTPUT o8 o7 o6 o5 o4 o3 o2 o1	50N#6 RELAY OUTPUT o8 o7 o6 o5 o4 o3 o2 o1
<b>50N#3 INST RESID O/C</b> DISABLE enable	<b>50N#7 INST RESID O/C</b> DISABLE enable
50N#3 BLOCK INPUT i6 i5 i4 i3 i2 i1	50N#7 BLOCK INPUT i6 i5 i4 i3 i2 i1
50N#3 RELAY OUTPUT o8 o7 o6 o5 o4 o3 o2 o1	50N#7 RELAY OUTPUT o8 o7 o6 o5 o4 o3 o2 o1
<b>50N#4 INST RESID O/C</b> DISABLE enable	<b>50N#8 INST RESID O/C</b> DISABLE enable
50N#4 BLOCK INPUT i6 i5 i4 i3 i2 i1	50N#8 BLOCK INPUT i6 i5 i4 i3 i2 i1
50N#4 RELAY OUTPUT o8 o7 o6 o5 o4 o3 o2 o1	50N#8 RELAY OUTPUT o8 o7 o6 o5 o4 o3 o2 o1

Figure A-5 Functional Configuration Record Form As Shipped (Page 4 of 9)

CONFIGURE RELAY  
 ← ext brkr CONFIG →

<b>51N#1 INV TIME RESID O/C</b> DISABLE enable  51N#1 BLOCK INPUT i6 i5 i4 i3 i2 i1  51N#1 RELAY OUTPUT o8 o7 o6 o5 o4 o3 o2 o1	<b>87H HI SET DIFFERENTIAL</b> DISABLE enable  87H BLOCK INPUT i6 i5 i4 i3 i2 i1  87H RELAY OUTPUT o8 o7 o6 o5 o4 o3 o2 o1
<b>51N#2 INV TIME RESID O/C</b> DISABLE enable  51N#2 BLOCK INPUT i6 i5 i4 i3 i2 i1  51N#2 RELAY OUTPUT o8 o7 o6 o5 o4 o3 o2 o1	<b>87T DIFFERENTIAL CURRENT</b> DISABLE enable  87T BLOCK INPUT i6 i5 i4 i3 i2 i1  87T RELAY OUTPUT o8 o7 o6 o5 o4 o3 o2 o1
<b>51N#3 INV TIME RESID O/C</b> DISABLE enable  51N#3 BLOCK INPUT i6 i5 i4 i3 i2 i1  51N#3 RELAY OUTPUT o8 o7 o6 o5 o4 o3 o2 o1	
<b>51N#4 INV TIME RESID O/C</b> DISABLE enable  51N#4 BLOCK INPUT i6 i5 i4 i3 i2 i1  51N#4 RELAY OUTPUT o8 o7 o6 o5 o4 o3 o2 o1	

Figure A-5 Functional Configuration Record Form As Shipped (Page 5 of 9)

CONFIGURE RELAY  
 ← ext brkr CONFIG →

<b>87GDW2#1 GND DIFF</b> DISABLE enable  87GDW2#1 BLOCK INPUT i6 i5 i4 i3 i2 i1  87GDW2#1 RELAY OUTPUT o8 o7 o6 o5 o4 o3 o2 o1	<b>87GDW3#2 GND DIFF</b> DISABLE enable  87GDW3#2 BLOCK INPUT i6 i5 i4 i3 i2 i1  87GDW3#2 RELAY OUTPUT o8 o7 o6 o5 o4 o3 o2 o1	<b>50BFW1 BREAKER FAILURE</b> DISABLE enable  50BFW1 BLOCK INPUT i6 i5 i4 i3 i2 i1  50BFW1 RELAY OUTPUT o8 o7 o6 o5 o4 o3 o2 o1
<b>87GDW2#2 GND DIFF</b> DISABLE enable  87GDW2#2 BLOCK INPUT i6 i5 i4 i3 i2 i1  87GDW2#2 RELAY OUTPUT o8 o7 o6 o5 o4 o3 o2 o1	<b>87GDW4#1 GND DIFF</b> DISABLE enable  87GDW4#1 BLOCK INPUT i6 i5 i4 i3 i2 i1  87GDW4#1 RELAY OUTPUT o8 o7 o6 o5 o4 o3 o2 o1	<b>50BFW2 BREAKER FAILURE</b> DISABLE enable  50BFW2 BLOCK INPUT i6 i5 i4 i3 i2 i1  50BFW2 RELAY OUTPUT o8 o7 o6 o5 o4 o3 o2 o1
<b>87GDW3#1 GND DIFF</b> DISABLE enable  87GDW3#1 BLOCK INPUT i6 i5 i4 i3 i2 i1  87GDW3#1 RELAY OUTPUT o8 o7 o6 o5 o4 o3 o2 o1	<b>87GDW4#2 GND DIFF</b> DISABLE enable  87GDW4#2 BLOCK INPUT i6 i5 i4 i3 i2 i1  87GDW4#2 RELAY OUTPUT o8 o7 o6 o5 o4 o3 o2 o1	<b>50BFW3 BREAKER FAILURE</b> DISABLE enable  50BFW3 BLOCK INPUT i6 i5 i4 i3 i2 i1  50BFW3 RELAY OUTPUT o8 o7 o6 o5 o4 o3 o2 o1
		<b>50BFW4 BREAKER FAILURE</b> DISABLE enable  50BFW4 BLOCK INPUT i6 i5 i4 i3 i2 i1  50BFW4 RELAY OUTPUT o8 o7 o6 o5 o4 o3 o2 o1

Figure A-5 Functional Configuration Record Form As Shipped (Page 6 of 9)

CONFIGURE RELAY ← ext brkr CONFIG →	
CONFIGURE RELAY ← FREQUENCY_RELAY →	CONFIGURE RELAY ←VOLTS_PER_HZ_RELAY→
<p><b>81#1 FREQUENCY</b> DISABLE enable</p> <p>81#1 BLOCK INPUT i6 i5 i4 i3 i2 i1</p> <p>81#1 RELAY OUTPUT o8 o7 o6 o5 o4 o3 o2 o1</p>	<p><b>24DT#1 DEF TIME VOLTS/HZ</b> DISABLE enable</p> <p>24DT#1 BLOCK INPUT i6 i5 i4 i3 i2 i1</p> <p>24DT#1 RELAY OUTPUT o8 o7 o6 o5 o4 o3 o2 o1</p>
<p><b>81#2 FREQUENCY</b> DISABLE enable</p> <p>81#2 BLOCK INPUT i6 i5 i4 i3 i2 i1</p> <p>81#2 RELAY OUTPUT o8 o7 o6 o5 o4 o3 o2 o1</p>	<p><b>24DT#2 DEF TIME VOLTS/HZ</b> DISABLE enable</p> <p>24DT#2 BLOCK INPUT i6 i5 i4 i3 i2 i1</p> <p>24DT#2 RELAY OUTPUT o8 o7 o6 o5 o4 o3 o2</p>
<p><b>81#3 FREQUENCY</b> DISABLE enable</p> <p>81#3 BLOCK INPUT i6 i5 i4 i3 i2 i1</p> <p>81#3 RELAY OUTPUT o8 o7 o6 o5 o4 o3 o2 o1</p>	<p><b>24IT INV TIME VOLTS/HZ</b> DISABLE enable</p> <p>24IT BLOCK INPUT i6 i5 i4 i3 i2 i1</p> <p>24IT RELAY OUTPUT o8 o7 o6 o5 o4 o3 o2 o1</p>
<p><b>81#4 FREQUENCY</b> DISABLE enable</p> <p>81#4 BLOCK INPUT i6 i5 i4 i3 i2 i1</p> <p>81#4 RELAY OUTPUT o8 o7 o6 o5 o4 o3 o2 o1</p>	

Figure A-5 Functional Configuration Record Form As Shipped (Page 7 of 9)

CONFIGURE RELAY  
 ← ext brkr CONFIG →

CONFIGURE RELAY  
 ← IPS LOGIC →

CONFIGURE RELAY  
 ← BREAKER\_MONITOR

<p><b>IPS#1 IPS LOGIC</b>                      DISABLE enable</p> <p>IPS#1 BLOCK INPUT                      i6 i5 i4 i3 i2 i1</p> <p>IPS#1 RELAY OUTPUT                      o8 o7 o6 o5 o4 o3 o2 o1</p>	<p><b>IPS#4 IPS LOGIC</b>                      DISABLE enable</p> <p>IPS#4 BLOCK INPUT                      i6 i5 i4 i3 i2 i1</p> <p>IPS#4 RELAY OUTPUT                      o8 o7 o6 o5 o4 o3 o2 o1</p>	<p><b>BRKRW1 BREAKER MONITOR</b>                      DISABLE enable</p> <p>BRKRW1 BLOCK INPUT                      i6 i5 i4 i3 i2 i1</p> <p>BRKRW1 RELAY OUTPUT                      o8 o7 o6 o5 o4 o3 o2 o1</p>
<p><b>IPS#2 IPS LOGIC</b>                      DISABLE enable</p> <p>IPS#2 BLOCK INPUT                      i6 i5 i4 i3 i2 i1</p> <p>IPS#2 RELAY OUTPUT                      o8 o7 o6 o5 o4 o3 o2 o1</p>	<p><b>IPS#5 IPS LOGIC</b>                      DISABLE enable</p> <p>IPS#5 BLOCK INPUT                      i6 i5 i4 i3 i2 i1</p> <p>IPS#5 RELAY OUTPUT                      o8 o7 o6 o5 o4 o3 o2 o1</p>	<p><b>BRKRW2 BREAKER MONITOR</b>                      DISABLE enable</p> <p>BRKRW2 BLOCK INPUT                      i6 i5 i4 i3 i2 i1</p> <p>BRKRW2 RELAY OUTPUT                      o8 o7 o6 o5 o4 o3 o2 o1</p>
<p><b>IPS#3 IPS LOGIC</b>                      DISABLE enable</p> <p>IPS#3 BLOCK INPUT                      i6 i5 i4 i3 i2 i1</p> <p>IPS#3 RELAY OUTPUT                      o8 o7 o6 o5 o4 o3 o2 o1</p>	<p><b>IPS#6 IPS LOGIC</b>                      DISABLE enable</p> <p>IPS#6 BLOCK INPUT                      i6 i5 i4 i3 i2 i1</p> <p>IPS#6 RELAY OUTPUT                      o8 o7 o6 o5 o4 o3 o2 o1</p>	<p><b>BRKRW3 BREAKER MONITOR</b>                      DISABLE enable</p> <p>BRKRW3 BLOCK INPUT                      i6 i5 i4 i3 i2 i1</p> <p>BRKRW3 RELAY OUTPUT                      o8 o7 o6 o5 o4 o3 o2 o1</p>
		<p><b>BRKRW4 BREAKER MONITOR</b>                      DISABLE enable</p> <p>BRKRW4 BLOCK INPUT                      i6 i5 i4 i3 i2 i1</p> <p>BRKRW4 RELAY OUTPUT                      o8 o7 o6 o5 o4 o3 o2 o1</p>

Figure A-5 Functional Configuration Record Form As Shipped (Page 8 of 9)

CONFIGURE RELAY ← ext brkr CONFIG →	
CONFIGURE RELAY ← THROUGH FAULT →	CONFIGURE RELAY ← TCM MONITOR →
<b>THFLT THROUGH FAULT</b> DISABLE enable  THFLT BLOCK INPUT i6 i5 i4 i3 i2 i1  THFLT RELAY OUTPUT o8 o7 o6 o5 o4 o3 o2 o1	<b>TCM TRIP CKT MONITOR</b> DISABLE enable  TCM BLOCK INPUT i6 i5 i4 i3 i2 i1  TCM RELAY OUTPUT o8 o7 o6 o5 o4 o3 o2 o1

Figure A-5 Functional Configuration Record Form As Shipped (Page 9 of 9)

SETUP SYSTEM ← config SYS stat dmd →		
<b>INPUT ACTIVATED PROFILES</b> IN ap cpy volt vt →	W1 INCLUDE IN WIN SUM#1 NO yes	<b>CUSTOM XFM/CT CONNECTION</b> ← CONN phase seal in →
INPUT ACTIVATED PROFILES DISABLE enable	W2 INCLUDE IN WIN SUM#1 NO yes	CUSTOM XFM/CT CONNECTION DISABLE enable
<b>ACTIVE SETPOINT PROFILE</b> in AP cpy volt vt →	W3 INCLUDE IN WIN SUM#1 NO yes	W1 XFM PHASE COMP TYPE <u>0</u>
ACTIVE SETPOINT PROFILE <u>1</u>	W4 INCLUDE IN WIN SUM#1 NO yes	W2 XFM PHASE COMP TYPE <u>0</u>
<b>COPY ACTIVE PROFILE</b> in ap CPY volt vt →	W1 INCLUDE IN WIN SUM#2 NO yes	W3 XFM PHASE COMP TYPE <u>0</u>
COPY ACTIVE PROFILE TO_PROFILE_1 →	W2 INCLUDE IN WIN SUM#2 NO yes	W4 XFM PHASE COMP TYPE <u>0</u>
COPY ACTIVE PROFILE TO_PROFILE_2 →	W3 INCLUDE IN WIN SUM#2 NO yes	W1 CT PH/MAG COMP TYPE <u>0</u>
COPY ACTIVE PROFILE TO_PROFILE_3 →	W4 INCLUDE IN WIN SUM#2 NO yes	W2 CT PH/MAG COMP TYPE <u>0</u>
COPY ACTIVE PROFILE TO_PROFILE_4 →		W3 CT PH/MAG COMP TYPE <u>0</u>
<b>NOMINAL VOLTAGE</b> in ap cpy VOLT vt →		W4 CT PH/MAG COMP TYPE <u>0</u>
NOMINAL VOLTAGE <u>120</u> Volts		W1 ZERO SEQ COMP DISABLE enable
<b>V.T. CONFIGURATION</b> in ap cpy volt VT →		W2 ZERO SEQ COMP DISABLE enable
V.T. CONFIGURATION vab vbc vca VA vb vc		W3 ZERO SEQ COMP DISABLE enable
<b>NUMBER OF WINDINGS</b> ← NUM_OF_WINDINGS →		W4 ZERO SEQ COMP DISABLE enable
NUMBER OF WINDINGS THREE four		
<b>WINDING SUMMING</b> ← num_of_windings SUM →		

Figure A-6 Unit Setup and Communication Data Record Form As Shipped (Page 1 of 5)

SETUP SYSTEM ← config SYS stat dmd →		
<b>CT CONNECTION W1</b> ←CON_W1 XFm_W1 con_w2→	<b>CT CONNECTION W3</b> ←XFm_w2 CON_W3 XFm_W3→	<b>RELAY SEAL-IN TIME</b> ← conn phase SEAL in →  RELAY SEAL-IN TIME OUT1 <u>    30    </u> Cycles  RELAY SEAL-IN TIME OUT2 <u>    30    </u> Cycles  RELAY SEAL-IN TIME OUT3 <u>    30    </u> Cycles  RELAY SEAL-IN TIME OUT4 <u>    30    </u> Cycles  RELAY SEAL-IN TIME OUT5 <u>    30    </u> Cycles  RELAY SEAL-IN TIME OUT6 <u>    30    </u> Cycles  RELAY SEAL-IN TIME OUT7 <u>    30    </u> Cycles  RELAY SEAL-IN TIME OUT8 <u>    30    </u> Cycles  RELAY SEAL-IN TIME OUT9 <u>    30    </u> Cycles  RELAY SEAL-IN TIME OUT10 <u>    30    </u> Cycles  RELAY SEAL-IN TIME OUT11 <u>    30    </u> Cycles  RELAY SEAL-IN TIME OUT12 <u>    30    </u> Cycles  RELAY SEAL-IN TIME OUT13 <u>    30    </u> Cycles  RELAY SEAL-IN TIME OUT14 <u>    30    </u> Cycles  RELAY SEAL-IN TIME OUT15 <u>    30    </u> Cycles  RELAY SEAL-IN TIME OUT16 <u>    30    </u> Cycles
<b>CT CONNECTION W1</b> Y dab dac inv_y → ← inv_dab inv_dac	<b>CT CONNECTION W3</b> Y dab dac inv_y → ← inv_dab inv_dac	
<b>XFM CONNECTION W1</b> ←CON_W1 XFM_W1 CON_W2→	<b>XFM CONNECTION W3</b> ←XFM_W2 CON_w3 XFM_W3→	
<b>XFM CONNECTION W1</b> Y dab dac inv_y → ← inv_dab inv_dac	<b>XFM CONNECTION W3</b> Y dab dac inv_y → ← inv_dab inv_dac	
<b>CT CONNECTION W2</b> ←con_w1 XFm_W1 CON_W2→	<b>CT CONNECTION W4</b> ←XFm_w3 CON_W4 XFm_W4→	
<b>CT CONNECTION W2</b> Y dab dac inv_y → ← inv_dab inv_dac	<b>CT CONNECTION W4</b> Y dab dac inv_y → ← inv_dab inv_dac	
<b>XFM CONNECTION W2</b> ←XFM_W2 CON_W3 xfm_w3→	<b>XFM CONNECTION W4</b> ←XFM_W3 CON_w4 XFM_W4→	
<b>XFM CONNECTION W2</b> Y dab dac inv_y → ← inv_dab inv_dac	<b>XFM CONNECTION W4</b> Y dab dac inv_y → ← inv_dab inv_dac	
<b>PHASE ROTATION</b> ← conn PHASE seal in →  PHASE ROTATION a_c_b    A_B_C		

Figure A-6 Unit Setup and Communication Data Record Form *As Shipped* (Page 2 of 5)

SETUP SYSTEM  
 ← config SYS stat dmd →

<p><b>ACTIVE INPUT STATE</b> ←conn phase seal IN→</p> <p>ACTIVE INPUT OPEN/CLOSE i6 i5 i4 i3 i2 <u>i1</u></p> <p><b>V.T.Ø RATIO</b> ←VTX vtg ct_w1 ct_w2→</p> <p>V.T.Ø RATIO _____ 1.0 _____:1</p> <p><b>V.T.g RATIO</b> ←vtx VTG ct_w1 ct_w2→</p> <p>V.T.g RATIO _____ 1.0 _____:1</p> <p><b>W1 C.T. RATIO</b> ←vtx vts CT_W1 ct_w2→</p> <p>W1 C.T. RATIO _____ 10.0 _____:1</p> <p><b>W2 C.T. RATIO</b> ←vtx vts ct_W1 CT_w2→</p> <p>W2 C.T. RATIO _____ 10.0 _____:1</p>	<p><b>W2 C.T. GROUND RATIO</b> ←CT_w2G ct_w3 ct_w3g→</p> <p>W2 C.T. GROUND RATIO _____ 10.0 _____:1</p> <p><b>W3 C.T. RATIO</b> ←ct_W1 ct_w2 CT_w3→</p> <p>W3 C.T. RATIO _____ 10.0 _____:1</p> <p><b>W3 C.T. GROUND RATIO</b> ← CT_W3G ct_w3 CT_W3G →</p> <p>W3 C.T. GROUND RATIO _____ 10.0 _____:1</p> <p><b>W4 C.T. RATIO</b> ←ct_W4 ct_w4g→</p> <p>W4 C.T. RATIO _____ 10.0 _____:1</p> <p><b>W4 C.T. GROUND RATIO</b> ← ct_w4g CT_W4G →</p> <p>W4 C.T. GROUND RATIO _____ 10.0 _____:1</p>
---	--

Figure A-6 Unit Setup and Communication Data Record Form As Shipped (Page 3 of 5)

COMMUNICATION	
← targets osc_rec COMM→	
<p><b>COM1 SETUP</b> com1 com2 com3 com_adr→</p> <p>COM1 BAUD RATE ← baud_300 baud_600 → ←baud 1200 baud_2400→ ←baud_4800 BAUD_9600</p> <p><b>COM2 SETUP</b> com1 COM2 com3 com_adr→</p> <p>COM2 BAUD RATE ←baud_300 baud_600→ ←baud 1200 baud_2400→ ←baud 4800 BAUD_9600</p> <p>COM2 DEAD SYNC TIME _____ms 50</p> <p>COM2 PROTOCOL BEC02200 modbus dnp3</p> <p><b>COM3 SETUP</b> com1 com2 COM3 com_adr→</p> <p>COM3 DEAD SYNC TIME _____ms 50</p> <p>COM3 PROTOCOL BEC02200 modbus dnp3</p> <p><b>COMMUNICATION ADDRESS</b> com1 com2 com3 COM_ADR→</p> <p>COMMUNICATION ADDRESS _____1</p> <p><b>RESPONSE TIME DELAY</b> DLY access eth eth_ip</p> <p>RESPONSE TIME DELAY _____ms</p> <p><b>COMM ACCESS CODE</b> ← dly ACCESS eth eth_ip</p> <p>COMM ACCESS CODE _____9999</p>	<p><b>ETHERNET SETUP</b> ← dly accss ETH eth_ip</p> <p>ETHERNET disable ENABLE</p> <p>TCP/IP SETTINGS TCP prot</p> <p>SELECT PROTOCOL MODBUS serconv</p> <p>DHCP PROTOCOL disable ENABLE</p> <p>DHCP PROTOCOL DISABLE enable</p> <p>IP ADDRESS _____</p> <p>NET MASK _____</p> <p>GATEWAY _____</p> <p>ETHERNET PROTOCOL tcp PROT</p> <p>SELECT PROTOCOL modbus serconv</p> <p><b>ETHERNET ADDRESS</b> ← accss eth ETH_IP</p> <p>ETHERNET IP ADDRESS XX.XX.XX.XX</p> <p>After Exit to Comm menu, the following will be displayed (if any changes have been made in ethernet menu)</p> <p>CONFIGURING ETH...</p> <p>ETHERNET IP ADDRESS XX.XX.XX.XX</p>

Figure A-6 Unit Setup and Communication Data Record Form As Shipped (Page 4 of 5)

SETUP UNIT  
← SETUP

<p><b>SOFTWARE VERSION</b> VERS sn access number→</p> <p>SOFTWARE VERSION D-0179VXX.XX.XX XXXX</p> <p><b>SERIAL NUMBER</b> vers SN access number→</p> <p>SERIAL NUMBER _____</p> <p><b>ALTER ACCESS CODES</b> vers sn ACCESS number→</p> <p>ENTER ACCESS CODE LEVEL#1 level#2 level#3</p> <p>LEVEL #1 _____1111_____</p> <p>ENTER ACCESS CODE level#1 LEVEL#2 level#3</p> <p>LEVEL #2 _____2222_____</p> <p>ENTER ACCESS CODE level#1 level#2 LEVEL#3</p> <p>LEVEL #3 _____9999_____</p>	<p><b>USER CONTROL NUMBER</b> vers sn access NUMBER→</p> <p>USER CONTROL NUMBER _____1_____</p> <p><b>USER LOGO LINE 1</b> ←LOGO1 logo2 out alrm→</p> <p>USER LOGO LINE 1 <u>Beckwith Electric Co.</u></p> <p><b>USER LOGO LINE 2</b> ←logo1 LOGO2 out alrm</p> <p>USER LOGO LINE 2 _____M-3311A_____</p> <p><b>CLEAR OUTPUT COUNTERS</b> ←logo1 logo2 OUT alrm→</p> <p>CLEAR OUTPUT COUNTERS PRESS ENTER KEY TO CLEAR</p> <p><b>CLEAR ALARM COUNTER</b> ←logo1 logo2 out ALRM→</p> <p>CLEAR ALARM COUNTER PRESS ENTER KEY TO CLEAR</p>	<p><b>DATE &amp; TIME</b> ← TIME error diag</p> <p>DATE &amp; TIME 03-JAN-1998 01:00:80</p> <p>DATE &amp; TIME _____ Year</p> <p>DATE &amp; TIME jan feb mar apr may →</p> <p>DATE &amp; TIME _____ Date</p> <p>DATE &amp; TIME sun mon tue wed thu →</p> <p>DATE &amp; TIME _____ Hour</p> <p>DATE &amp; TIME _____ Minutes</p> <p>DATE &amp; TIME Seconds</p> <p><b>CLEAR ERROR CODES</b> ← time ERROR diag</p> <p>CLEAR ERROR CODES PRESS ENTER KEY TO CLEAR</p> <p><b>DIAGNOSTIC MODE</b> ← time error DIAG</p> <p>PROCESSOR WILL RESET ENTER KEY TO CONTINUE</p>
--	---	---

Figure A-6 Unit Setup and Communication Data Record Form As Shipped (Page 5 of 5)

VOLTAGE RELAY  
VOLT curr freq v/hz →

<p><b>27 PHASE UNDERVOLTAGE</b> VOLT_UNDER g_over</p> <p>27 PICKUP     <u>108</u> Volts</p> <p>27 INHIBIT DISABLE enable</p> <p>27 INHIBIT     _____ Volts</p> <p>27 DELAY     <u>30</u> Cycles</p> <p><b>59G GROUND OVERVOLTAGE</b> volt_under G_OVER</p> <p>59G#1 PICKUP     <u>10</u> Volts</p> <p>59G#1 DELAY     <u>30</u> Cycles</p> <p>59G#2 PICKUP     <u>10</u> Volts</p> <p>59G#2 DELAY     <u>30</u> Cycles</p>	<p><b>46 NEGSEQ OVERCURRENT</b> NEG_SEQ therm inst →</p> <p>46DTW2 PICKUP     <u>0.50</u> Amps</p> <p>46DTW2 DELAY     <u>120</u> Cycles</p> <p>46ITW2 PICKUP     <u>1.0</u> Amps</p> <p>46ITW2 CURVE BEDEF beinv bevinv beeinv→ ←ieci iecvi iecei ieclti→ ←ieemi ieevi ieeei</p> <p>46ITW2 TIME DIAL     <u>5.0</u></p> <p>46DTW3 PICKUP     <u>0.50</u> Amps</p> <p>46DTW3 DELAY     <u>120</u> Cycles</p> <p>46ITW3 PICKUP     <u>1.00</u> Amps</p> <p>46ITW3 CURVE BEDEF beinv bevinv beeinv→ ←ieci iecvi iecei ieclti→ ←ieemi ieevi ieeei</p>	<p>46ITW3 TIME DIAL     <u>5.0</u></p> <p>46DTW4 PICKUP     <u>0.50</u> Amps</p> <p>46DTW4 DELAY     <u>120</u> Cycles</p> <p>46ITW4 PICKUP     <u>1.00</u> Amps</p> <p>46ITW4 CURVE BEDEF beinv bevinv beeinv→ ←ieci iecvi iecei ieclti→ ←ieemi ieevi ieeei</p> <p>46ITW4 TIME DIAL     <u>5.0</u></p> <p><b>49 WINDING THERM. PROT</b> neg_seq THERM inst →</p> <p>49 TIME CONSTANT     <u>5.0</u> Min</p> <p>49 MAX OVERLOAD CURR.     <u>2.00</u> Amps</p> <p>49 WINDING SELECT sum1 sum2 W1 w2 w3 w4</p>
--	--	---

Figure A-7 Setpoint & Timing Record Form As Shipped (Page 1 of 14)

VOLTAGE RELAY  
 VOLT curr freq v/hz →

<b>50 INST OVERCURRENT</b> neg_seq therm INST	50#3 DELAY _____ 30 _____ Cycles	50#6 WINDING SELECT sum1 sum2 w1 w2 W3 w4
50#1 PICKUP _____ 1.0 _____ Amps	50#4 PICKUP _____ 1.0 _____ Amps	50#6 DELAY _____ 30 _____ Cycles
50#1 CURRENT SELECTION sum1 sum2 W1 w2 w3 w4	50#4 CURRENT SELECTION sum1 sum2 w1 W2 w3 w4	50#7 PICKUP _____ 1.0 _____ Amps
50#1 DELAY _____ 30 _____ Cycles	50#4 DELAY _____ 30 _____ Cycles	50#7 CURRENT SELECTION sum1 sum2 w1 w2 w3 W4
50#2 PICKUP _____ 1.0 _____ Amps	50#5 PICKUP _____ 1.0 _____ Amps	50#7 DELAY _____ 30 _____ Cycles
50#2 CURRENT SELECTION sum1 sum2 W1 w2 w3 w4	50#5 CURRENT SELECTION sum1 sum2 w1 w2 W3 w4	50#8 PICKUP _____ 1.0 _____ Amps
50#2 DELAY _____ 30 _____ Cycles	50#5 DELAY _____ 30 _____ Cycles	50#8 CURRENT SELECTION sum1 sum2 w1 w2 w3 W4
50#3 PICKUP _____ 1.0 _____ Amps	50#6 PICKUP _____ 1.0 _____ Amps	50#8 DELAY _____ 30 _____ Cycles
50#3 WINDING SELECT sum1 sum2 w1 W2 w3 w4		

Figure A-7 Setpoint & Timing Record Form As Shipped (Page 2 of 14)

51 INV TIME OVERCURRENT ← INV g_inst g_inv →	50G INST GND OVERCURRENT ← inv G_INST g_inv →	51G INV TIME GND O/C ← inv g_inst G_INV →
51#1 PICKUP <u>1.0</u> Amps	50GW2#1 PICKUP <u>1.0</u> Amps	51GW2 PICKUP <u>1.0</u> Amps
51#1 CURVE BEDEF beinv bevinv beeinv→ ←ieci iecvi iecwi iecwti→ ←ieemi ieevi ieeei	50GW2#1 DELAY <u>30</u> Cycles	51GW2 CURVE BEDEF beinv bevinv beeinv→ ←ieci iecvi iecwi iecwti→ ←ieemi ieevi ieeei
51#1 TIME DIAL <u>5.0</u>	50GW2#2 PICKUP <u>1.0</u> Amps	51GW2 TIME DIAL <u>5.0</u>
51#1 CURRENT SELECTION sum1 sum2 W1 w2 w3 w4	50GW2#2 DELAY <u>30</u> Cycles	51GW3 PICKUP <u>1.0</u> Amps
51#2 PICKUP <u>1.0</u> Amps	50GW3#1 PICKUP <u>1.0</u> Amps	51GW3 CURVE BEDEF beinv bevinv beeinv→ ←ieci iecvi iecwi iecwti→ ←ieemi ieevi ieeei
51#2 CURVE BEDEF beinv bevinv beeinv→ ←ieci iecvi iecwi iecwti→ ←ieemi ieevi ieeei	50GW3#1 DELAY <u>30</u> Cycles	51GW3 TIME DIAL <u>5.0</u>
51#2 TIME DIAL <u>5.0</u>	50GW3#2 PICKUP <u>1.0</u> Amps	51GW4 PICKUP <u>1.0</u> Amps
51#2 CURRENT SELECTION sum1 sum2 w1 W2 w3 w4	50GW3#2 DELAY <u>30</u> Cycles	51GW4 CURVE BEDEF beinv bevinv beeinv→ ←ieci iecvi iecwi iecwti→ ←ieemi ieevi ieeei
51#3 PICKUP <u>1.0</u> Amps	50GW4#1 PICKUP <u>1.0</u> Amps	51GW4 TIME DIAL <u>5.0</u>
51#3 CURVE BEDEF beinv bevinv beeinv→ ←ieci iecvi iecwi iecwti→ ←ieemi ieevi ieeei	50GW4#1 DELAY <u>30</u> Cycles	
51#3 TIME DIAL <u>5.0</u>	50GW4#2 PICKUP <u>1.0</u> Amps	
51#3 CURRENT SELECTION sum1 sum2 w1 w2 W3 w4	50GW4#2 DELAY <u>30</u> Cycles	
51#4 CURVE BEDEF beinv bevinv beeinv→ ←ieci iecvi iecwi iecwti→ ←ieemi ieevi ieeei		
51#4 TIME DIAL <u>5.0</u>		
51#4 CURRENT SELECTION sum1 sum2 w1 w2 w3 W4		

Figure A-7 Setpoint & Timing Record Form As Shipped  
(Page 3 of 14)

50N INST RESIDUAL O/C  
← R\_INST r\_inv diff →

50N#1 PICKUP <u>1.0</u> Amps	50N#5 PICKUP <u>1.0</u> Amps
50N#1 CURRENT SELECTION sum1 sum2 W1 w2 w3 w4	50N#5 CURRENT SELECTION sum1 sum2 w1 w2 W3 w4
50N#1 DELAY <u>30</u> Cycles	50N#5 DELAY <u>30</u> Cycles
50N#2 PICKUP <u>1.0</u> Amps	50N#6 PICKUP <u>1.0</u> Amps
50N#2 CURRENT SELECTION sum1 sum2 W1 w2 w3 w4	50N#6 CURRENT SELECTION sum1 sum2 w1 w2 W3 w4
50N#2 DELAY <u>30</u> Cycles	50N#6 DELAY <u>30</u> Cycles
50N#3 PICKUP <u>1.0</u> Amps	50N#7 PICKUP <u>1.0</u> Amps
50N#3 CURRENT SELECTION sum1 sum2 w1 W2 w3 w4	50N#7 CURRENT SELECTION sum1 sum2 w1 w2 w3 W4
50N#3 DELAY <u>30</u> Cycles	50N#7 DELAY <u>30</u> Cycles
50N#4 PICKUP <u>1.0</u> Amps	50N#8 PICKUP <u>1.0</u> Amps
50N#4 CURRENT SELECTION sum1 sum2 w1 W2 w3 w4	50N#8 CURRENT SELECTION sum1 sum2 w1 w2 w3 W4
50N#4 DELAY <u>30</u> Cycles	50N#8 DELAY <u>30</u> Cycles

Figure A-7 Setpoint & Timing Record Form *As Shipped* (Page 4 of 14)

51 INV TIME OVERCURRENT  
← inv g\_inst g\_inv →

50G INST GND OVERCURRENT  
← inv G\_INST g\_inv →

51#1 PICKUP <u>1.0</u> Amps	51#3 PICKUP <u>1.0</u> Amps
51#1 CURVE BEDEF beinv bevinv beeinv→ ←ieci iecvi iecei ieclti→ ←ieemi ieevi ieeei	51#3 CURVE BEDEF beinv bevinv beeinv→ ←ieci iecvi iecei ieclti→ ←ieemi ieevi ieeei
51#1 TIME DIAL <u>5.0</u>	51#3 TIME DIAL <u>5.0</u>
51#1 CURRENT SELECTION sum1 sum2 W1 w2 w3 w4	51#3 CURRENT SELECTION sum1 sum2 w1 w2 W3 w4
51#2 PICKUP <u>1.0</u> Amps	51#4 PICKUP <u>1.0</u> Amps
51#2 CURVE BEDEF beinv bevinv beeinv→ ←ieci iecvi iecei ieclti→ ←ieemi ieevi ieeei	51#4 CURVE BEDEF beinv bevinv beeinv→ ←ieci iecvi iecei ieclti→ ←ieemi ieevi ieeei
51#2 TIME DIAL <u>5.0</u>	51#4 TIME DIAL <u>5.0</u>
51#2 CURRENT SELECTION sum1 sum2 w1 W2 w3 w4	51#4 CURRENT SELECTION sum1 sum2 w1 w2 w3 W4

50GW2#1 PICKUP <u>1.0</u> Amps
50GW2#1 DELAY <u>30</u> Cycles
50GW2#2 PICKUP <u>1.0</u> Amps
50GW2#2 DELAY <u>30</u> Cycles
50GW3#1 PICKUP <u>1.0</u> Amps
50GW3#1 DELAY <u>30</u> Cycles
50GW3#2 PICKUP <u>1.0</u> Amps
50GW3#2 DELAY <u>30</u> Cycles
50GW4#1 PICKUP <u>1.0</u> Amps
50GW4#1 DELAY <u>30</u> Cycles
50GW4#2 PICKUP <u>1.0</u> Amps
50GW4#2 DELAY <u>30</u> Cycles

Figure A-7 Setpoint & Timing Record Form As Shipped (Page 5 of 14)

51G INV TIME GND O/C  
 ← inv g\_inst G\_INV →

50N INST RESIDUAL O/C  
 ← R\_INST r\_inv diff →

51GW2 PICKUP  
 \_\_\_\_\_  
 1.0 Amps

51GW2 CURVE  
 BEDEF beinv bevinv beeinv→  
 ←ieci iecvi iecwi iecwti→  
 ←ieemi ieevi ieeei

51GW2 TIME DIAL  
 \_\_\_\_\_  
 5.0

51GW3 PICKUP  
 \_\_\_\_\_  
 1.0 Amps

51GW3 CURVE  
 BEDEF beinv bevinv beeinv→  
 ←ieci iecvi iecwi iecwti→  
 ←ieemi ieevi ieeei

51GW3 TIME DIAL  
 \_\_\_\_\_  
 5.0

51GW4 PICKUP  
 \_\_\_\_\_  
 1.0 Amps

51GW4 CURVE  
 BEDEF beinv bevinv beeinv→  
 ←ieci iecvi iecwi iecwti→  
 ←ieemi ieevi ieeei

51GW4 TIME DIAL  
 \_\_\_\_\_  
 5.0

50N#1 PICKUP _____	50N#5 PICKUP _____
1.0 Amps	1.0 Amps
50N#1 CURRENT SELECTION sum1 sum2 W1 w2 w3 w4	50N#5 CURRENT SELECTION sum1 sum2 w1 w2 W3 w4
50N#1 DELAY _____	50N#5 DELAY _____
30 Cycles	30 Cycles
50N#2 PICKUP _____	50N#6 PICKUP _____
1.0 Amps	1.0 Amps
50N#2 CURRENT SELECTION sum1 sum2 W1 w2 w3 w4	50N#6 CURRENT SELECTION sum1 sum2 w1 w2 W3 w4
50N#2 DELAY _____	50N#6 DELAY _____
30 Cycles	30 Cycles
50N#3 PICKUP _____	50N#7 PICKUP _____
1.0 Amps	1.0 Amps
50N#3 CURRENT SELECTION sum1 sum2 W1 w2 w3 w4	50N#7 CURRENT SELECTION sum1 sum2 w1 w2 w3 W4
50N#3 DELAY _____	50N#7 DELAY _____
30 Cycles	30 Cycles
50N#4 PICKUP _____	50N#8 PICKUP _____
1.0 Amps	1.0 Amps
50N#4 CURRENT SELECTION sum1 sum2 w1 W2 w3 w4	50N#8 CURRENT SELECTION sum1 sum2 w1 w2 w3 W4
50N#4 DELAY _____	50N#8 DELAY _____
30 Cycles	30 Cycles

Figure A-7 Setpoint & Timing Record Form As Shipped (Page 6 of 14)

51N INV TIME RESID. 0/C  
 ← r\_inst R\_INV diff →

87 DIFFERENTIAL OVERCURP  
 ← r\_inst r\_inv DIFF

51N#1 PICKUP 1.0 Amps	51N#3 PICKUP 1.0 Amps
51N#1 CURVE BEDEF beinv bevinv beeinv→ ←ieci iecvi iecei ieclti→ ←ieemi ieevi ieeei	51N#3 CURVE BEDEF beinv bevinv beeinv→ ←ieci iecvi iecei ieclti→ ←ieemi ieevi ieeei
51N#1 TIME DIAL 5.0	51N#3 TIME DIAL 5.0
50N#1 CURRENT SELECTION sum1 sum2 W1 w2 w3 w4	50N#3 CURRENT SELECTION sum1 sum2 w1 w2 W3 w4
51N#2 PICKUP 1.0 Amps	51N#4 PICKUP 1.0 Amps
51N#2 CURVE BEDEF beinv bevinv beeinv→ ←ieci iecvi iecei ieclti→ ←ieemi ieevi ieeei	51N#4 CURVE BEDEF beinv bevinv beeinv→ ←ieci iecvi iecei ieclti→ ←ieemi ieevi ieeei
51N#2 TIME DIAL 5.0	51N#4 TIME DIAL 5.0
51N#2 CURRENT SELECTION sum1 sum2 w1 W2 w3 w4	51N#4 CURRENT SELECTION sum1 sum2 w1 w2 w3 W4

87H PICKUP 20.0 PU
87H DELAY 2 Cycles
87T PICKUP 0.50 PU
87T SLOPE #1 25 %
87T SLOPE #2 75 %
87T SLOPE BREAKPOINT 2.0 PU
87T EVEN RESTRAINT disable enable CROSS_AVG
87T EVEN RESTRAINT 10 %
87T 5TH RESTRAINT disable enable CROSS_AVG
87T 5TH RESTRAINT 10 %
87T PICKUP @5TH RESTRAIN 0.75 PU
87 W1 C.T. TAP 1.00
87 W2 C.T. TAP 1.00
87 W3 C.T. TAP 1.00
87 W4 C.T. TAP 1.00

Figure A-7 Setpoint & Timing Record Form As Shipped (Page 7 of 14)

87GD GND DIFF OVERCURR  
← G\_DIFF brk\_fail

87GDW2#1 PICKUP <u>0.20</u> Amps	87GDW4#1 PICKUP <u>0.20</u> Amps
87GDW2#1 DELAY <u>2</u> Cycles	87GDW4#1 DELAY <u>2</u> Cycles
87GDW2#2 PICKUP <u>1.00</u> Amps	87GDW4#2 PICKUP <u>1.00</u> Amps
87GDW2#2 DELAY <u>2</u> Cycles	87GDW4#2 DELAY <u>2</u> Cycles
87GDW2 C.T. RATIO CORR. <u>1.00</u>	87GDW4 C.T. RATIO CORR. <u>1.00</u>
87GDW2 DIR ELEMENT DISABLE enable	87GDW4 DIR ELEMENT DISABLE enable
87GDW2 CURRENT SELECTION SNGL_win sum1 sum2	87GDW4 CURRENT SELECTION SNGL_win sum1 sum2
87GDW3#1 PICKUP <u>0.20</u> Amps	
87GDW3#1 DELAY <u>2</u> Cycles	
87GDW3#2 PICKUP <u>1.00</u> Amps	
87GDW3#2 DELAY <u>2</u> Cycles	
87GDW3 C.T. RATIO CORR. <u>1.00</u>	
87GDW3 DIR ELEMENT DISABLE enable	
87GDW3 CURRENT SELECTION SNGL_win sum1 sum2	

Figure A-7 Setpoint & Timing Record Form *As Shipped* (Page 8 of 14)

50BF BREAKER FAILURE  
← g\_diff BRK\_FAIL

FREQUENCY RELAY  
volt curr FREQ v/hz →

50BFW1 PICKUP RESIDUAL _____ 1.0 _____ Amps	50BFW3 PICKUP RESIDUAL _____ 1.0 _____ Amps
50BFW1 PICKUP PHASE _____ 1.0 _____ Amps	50BFW3 PICKUP PHASE _____ 1.0 _____ Amps
50BFW1 INPUT INITIATE i6 i5 i4 i3 i2 i1	50BFW3 INPUT INITIATE i6 i5 i4 i3 i2 i1
50BFW1 OUTPUT INITIATE o8 o7 o6 o5 o4 o3 o2 o1	50BFW3 OUTPUT INITIATE o8 o7 o6 o5 o4 o3 o2 o1
50BFW1 DELAY _____ 30 _____ Cycles	50BFW3 DELAY _____ 30 _____ Cycles
50BFW2 PICKUP RESIDUAL _____ 1.0 _____ Amps	50BFW4 PICKUP RESIDUAL _____ 1.0 _____ Amps
50BFW2 PICKUP PHASE _____ 1.0 _____ Amps	50BFW4 PICKUP PHASE _____ 1.0 _____ Amps
50BFW2 INPUT INITIATE i6 i5 i4 i3 i2 i1	50BFW4 INPUT INITIATE i6 i5 i4 i3 i2 i1
50BFW2 OUTPUT INITIATE o8 o7 o6 o5 o4 o3 o2 o1	50BFW4 OUTPUT INITIATE o8 o7 o6 o5 o4 o3 o2 o1
50BFW2 DELAY _____ 30 _____ Cycles	50BFW4 DELAY _____ 30 _____ Cycles

81U OVER/UNDER FREQUENCY FREQ
81#1 PICKUP _____ 56 _____ Hz
81#1 DELAY _____ 30 _____ Cycles
81#2 PICKUP _____ 56 _____ Hz
81#2 DELAY _____ 30 _____ Cycles
81#3 PICKUP _____ 56 _____ Hz
81#3 DELAY _____ 30 _____ Cycles
81#4 PICKUP _____ 56 _____ Hz
81#4 DELAY _____ 30 _____ Cycles

Figure A-7 Setpoint & Timing Record Form As Shipped (Page 9 of 14)

VOLTS PER HERTZ RELAY volt curr freq V/HZ →	24 INV TIME VOLTS/HERTZ def_v/hz INV_V/HZ
24 DEF TIME VOLTS/HERTZ DEF_V/HZ inv_v/hz	24IT PICKUP _____ 105 _____ %
24DT#1 PICKUP _____ 110 _____ %	24IT CURVE CRV#1 crv#2 crv#3 crv#4
24DT#1 DELAY _____ 360 _____ Cycles	24IT TIME DIAL _____ 9 _____
24DT#2 PICKUP _____ 110 _____ %	24IT RESET RATE _____ 200 _____ Seconds
24DT#2 DELAY _____ 360 _____ Cycles	

Figure A-7 Setpoint & Timing Record Form As *Shipped* (Page 10 of 14)

IPS LOGIC  
 IPS brkr thflt tcm →

IPS LOGIC  
 IPS

IPS#1 INPUT INITIATE i6 i5 i4 i3 i2 i1	IPS#4 INPUT INITIATE i6 i5 i4 i3 i2 i1
IPS#1 OUTPUT INITIATE o8 o7 o6 o5 o4 o3 o2 o1	IPS#4 OUTPUT INITIATE o8 o7 o6 o5 o4 o3 o2 o1
IPS#1 DELAY 30 Cycles	IPS#4 DELAY 30 Cycles
IPS#2 INPUT INITIATE i6 i5 i4 i3 i2 i1	IPS#5 INPUT INITIATE i6 i5 i4 i3 i2 i1
IPS#2 OUTPUT INITIATE o8 o7 o6 o5 o4 o3 o2 o1	IPS#5 OUTPUT INITIATE o8 o7 o6 o5 o4 o3 o2 o1
IPS#2 DELAY 30 Cycles	IPS#5 DELAY 30 Cycles
IPS#3 INPUT INITIATE i6 i5 i4 i3 i2 i1	IPS#6 INPUT INITIATE i6 i5 i4 i3 i2 i1
IPS#3 OUTPUT INITIATE o8 o7 o6 o5 o4 o3 o2 o1	IPS#6 OUTPUT INITIATE o8 o7 o6 o5 o4 o3 o2 o1
IPS#3 DELAY 30 Cycles	IPS#6 DELAY 30 Cycles

Figure A-7 Setpoint & Timing Record Form As *Shipped* (Page 11 of 14)

BREAKER MONITORING  
← ips BRKR thflt tcm →

BREAKER ACC. STATUS  
brkr STAT prst clr

<b>SET BREAKER MONITORING</b>	BRKRW3 PICKUP	W1 ACCUMULATOR
BRKR stat prst clr	<u>1000</u> kA-cycles	A= 0 A-cycles
BRKRW1 PICKUP	BRKRW3 INPUT INITIATE	W1 ACCUMULATOR
<u>1000</u> kA-cycles	i6 i5 i4 i3 i2 i1	B= 0 A-cycles
BRKRW1 INPUT INITIATE	BRKRW3 OUTPUT INITIATE	W1 ACCUMULATOR
i6 i5 i4 i3 i2 i1	o8 o7 o6 o5 o4 o3 o2 o1	C= 0 A-cycles
BRKRW1 OUTPUT INITIATE	BRKRW3 DELAY	W2 ACCUMULATOR
o8 o7 o6 o5 o4 o3 o2 o1	<u>10.0</u> Cycles	A= 0 A-cycles
BRKRW1 DELAY	BRKRW3 TIMING METHOD	W2 ACCUMULATOR
<u>10.0</u> Cycles	IT i2t	B= 0 A-cycles
BRKRW1 TIMING METHOD	BRKRW4 PICKUP	W2 ACCUMULATOR
IT i2t	<u>1000</u> kA-cycles	C= 0 A-cycles
BRKRW2 PICKUP	BRKRW4 INPUT INITIATE	W3 ACCUMULATOR
<u>1000</u> kA-cycles	i6 i5 i4 i3 i2 i1	A= 0 A-cycles
BRKRW2 INPUT INITIATE	BRKRW4 OUTPUT INITIATE	W3 ACCUMULATOR
i6 i5 i4 i3 i2 i1	o8 o7 o6 o5 o4 o3 o2 o1	B= 0 A-cycles
BRKRW2 OUTPUT INITIATE	BRKRW4 DELAY	W3 ACCUMULATOR
o8 o7 o6 o5 o4 o3 o2 o1	<u>10.0</u> Cycles	C= 0 A-cycles
BRKRW2 DELAY	BRKRW4 TIMING METHOD	W4 ACCUMULATOR
<u>10.0</u> Cycles	IT i2t	A= 0 A-cycles
BRKRW2 TIMING METHOD		W4 ACCUMULATOR
IT i2t		B= 0 A-cycles
		W4 ACCUMULATOR
		C= 0 A-cycles

Figure A-7 Setpoint & Timing Record Form As Shipped (Page 12 of 14)

PRESET ACCUMULATORS brkr stat PRST clr		CLEAR ACCUMULATORS brkr stat prst CLR	
ACC. A W1 SET A_W1 b_w1 c_w1 →	ACC. A W3 SET ←A_W3 b_w3 c_w3	ACC. A W1 CLEAR A_W1 b_w1 c_w1 →	
BRKR. ACCUMULATOR kA-cycles	BRKR. ACCUMULATOR _____ kA-cycles	ACC. B W1 CLEAR a_w1 B_W1 c_w1 →	
ACC. B W1 SET a_w1 B_W1 c_w1 →	ACC. B W3 SET ←a_w3 B_W3 c_w3	ACC. C W1 CLEAR a_w1 b_w1 C_W1 →	
BRKR. ACCUMULATOR _____ kA-cycles	BRKR. ACCUMULATOR _____ kA-cycles	ACC. A W2 CLEAR fA_W2 b_w2 c_w2→	
ACC. C W1 SET a_w1 b_w1 C_W1 →	ACC. C W3 SET ←a_w3 b_w3 C_W3	ACC B W2 CLEAR fa_w2 B_W2 c_w2→	
BRKR. ACCUMULATOR _____ kA-cycles	BRKR. ACCUMULATOR _____ kA-cycles	ACC C W2 CLEAR fa_w2 b_w2 C_W2→	
ACC. A W2 SET ←A_W2 b_w2 c_w2 →	ACC. A W4 SET ←A_W4 b_w4 c_w4	ACC A W3 CLEAR fA_W3 b_w3 c_w3→	
BRKR. ACCUMULATOR _____ kA-cycles	BRKR. ACCUMULATOR _____ kA-cycles	ACC B W3 CLEAR fa_w3 B_W3 c_w3→	
ACC. B W2 SET ←a_w2 B_W2 c_w2 →	ACC. B W4 SET ←a_w4 B_W4 c_w4	ACC C W3 CLEAR fa_w3 b_w3 C_W3→	
BRKR. ACCUMULATOR _____ kA-cycles	BRKR. ACCUMULATOR _____ kA-cycles	ACC A W4 CLEAR fA_W4 b_w4 c_w4	
ACC. C W2 SET ←a_w2 b_w2 C_W2 →	ACC. C W4 SET ←a_w4 b_w4 C_W4	ACC B W4 CLEAR fa_w4 B_W4 c_w4	
BRKR. ACCUMULATOR _____ kA-cycles	BRKR. ACCUMULATOR _____ kA-cycles	ACC C W4 CLEAR fa_w4 b_w4 C_W4	

Figure A-7 Setpoint & Timing Record Form As Shipped (Page 13 of 14)

THROUGH FAULT	
←ips brkr THFLT tcm →	
THFLT CURRENT THRESHOLD	
<u>10.0</u> Amps	
THFLT CUM. I <sup>2</sup> T LIMIT	
<u>100</u> kA <sup>2</sup> -cycles	
THFLT PU OPERATIONS LIM.	
<u>5</u> Records	
THFLT WINDING SELECT	
win1 WIN2 win3 win4	
THFLT DELAY	
<u>30</u> Cycles	
TRIP CIRCUIT MONITORING	
←ips brkr thflt TCM→	
TCM DELAY	
<u>30</u> Cycles	

Figure A-7 Setpoint & Timing Record Form As *Shipped* (Page 14 of 14)

FUNCTION	D	O U T P U T S								I N P U T S							
		8	7	6	5	4	3	2	1	6	5	4	3	2	1		
24 DEF TIME #1	✓																
24 DEF TIME #2	✓																
24 INV TIME	✓																
27	✓																
46 DEF TIME W2	✓																
46 INV TIME W2	✓																
46 DEF TIME W3	✓																
46 INV TIME W3	✓																
46 DEF TIME W4	✓																
46 INV TIME W4	✓																
49	✓																
50 #1	✓																
50 #2	✓																
50 #3	✓																
50 #4	✓																
50 #5	✓																
50 #6	✓																
50 #7	✓																
50 #8	✓																
50BFW1	✓																
50BFW2	✓																
50BFW3	✓																
50BFW4	✓																
50GW2 #1	✓																
50GW2 #2	✓																
50GW3 #1	✓																
50GW3 #2	✓																
50GW4 #1	✓																
50gw4 #2	✓																
50N #1	✓																
50N #2	✓																
50N #3	✓																
50N #4	✓																
50N #5	✓																
50N #6	✓																
50N #7	✓																
50N #8	✓																

Table A-2 Relay Configuration As Shipped (page 1 of 2)

FUNCTION	D	O U T P U T S								I N P U T S					
		8	7	6	5	4	3	2	1	6	5	4	3	2	1
51 #1	✓														
51 #2	✓														
51 #3	✓														
51 #4	✓														
51GW2	✓														
51GW3	✓														
51GW4	✓														
51N #1	✓														
51N #2	✓														
51N #3	✓														
51N #4	✓														
59G #1	✓														
59G #2	✓														
81 #1	✓														
81 #2	✓														
81 #3	✓														
81 #4	✓														
87H	✓														
87T	✓														
87GDW2	✓														
87GDW3	✓														
87GDW4	✓														
IPS #1	✓														
IPS #2	✓														
IPS #3	✓														
IPS #4	✓														
IPS #5	✓														
IPS #6	✓														
BM W1	✓														
BM W2	✓														
BM W3	✓														
BM W4	✓														
TCM	✓														
TF	✓														

Table A-2 Relay Configuration As Shipped (page 2 of 2)

# B Appendix – Communications

The M-3311A Transformer Protection Relay incorporates three serial ports for intelligent, digital communication with external devices. Equipment such as RTUs, data concentrators, modem, or computers can be interfaced for direct, on-line real time data acquisition and control.

Generally, all data available to the operator through the front panel of the relay, with the optional M-3931 HMI module is accessible remotely through the BECO 2200 data exchange protocol. This protocol document and the BECO 2200 relay database specified protocol document are available from the factory or our website at [www.beckwithelectric.com](http://www.beckwithelectric.com).

The M-3826B IPScom® Communication Software package has been supplied for communication to any IBM compatible computer running under Windows 95™ or higher.

The protocol implements serial, byte oriented, asynchronous communication, and can be used to fulfill the following communications functions:

- Real time monitoring of line status.
- Interrogation and modification of setpoints.
- Downloading of recorded oscillograph data.
- Reconfiguration of functions.

■ **NOTE:** The following restrictions apply for MODBUS protocol use:

1. MODBUS protocol is not supported on **COM1**
2. Parity is supported on **COM2** and **COM3** only, valid selections are 8,N,1; 8,O,1; 8,E,1; 8,N,2; 8,O,2; 8,E,2.
3. ASCII mode is not supported (RTU only)
4. Standard baud rates from 300 to 9600 are supported.

5. Only the following MODBUS commands are supported:
  - a. Read holding register (function 03)
  - b. Read input register (function 04)
  - c. Force single coil (function 05)
  - d. Preset single register (function 06)

For detailed information about communications, refer to Chapter 4, **IPScom Operation**.

## DNP Configuration Parameters

M-3311A relays support DNP through the rear RS-232 (COM2) & RS-485 (COM3) communication ports. These ports support baud rates 300, 600, 1200, 2400, 4800, 9600 (default baud rate is 9600). See Figure A-3, Communication Data & Unit Setup, for sequence of DNP setup screens.

## M-3311 Slave Address

DNP3 Slave IED address range is from 0 to 65519. Address 65535 (hex FFFF) is used to broadcast messages to all devices. The communication address can be set through the HMI (front panel; optional).

The DNP3 device profile document, including the point list, is available from the factory or our website, [www.beckwithelectric.com](http://www.beckwithelectric.com).

The following restrictions apply for DNP3 protocol use:

- DNP3 is not supported on COM1.
- Parity is not supported.
- DNP3 does not support oscillograph record downloading.

The communication database profile in M-3311A using DNP3 protocol is grouped into five object types:

1. **Single Bit Binary Inputs (Status):** (object 01, variation 01) These are considered as class 0 data.
2. **16 Bit Analog Output Block /Status (setpoints):** (object 40, variation 01, variation 02/object 41, variation 01, variation 02) Used to write and read all setpoints and system setup.
3. **Control Relay Output Block (direct control):** (object 12, variation 01) Used to write all configuration points.
4. **16 Bit Analog Inputs:** (object 30, variation 02) Used to represent all demand metering, target information, and control information of the relay.
5. **16 Bit Binary Counters:** (object 20, variation 02, variation 06) Used to represent all counters. Can be used to reset the counters using freeze and clear function code.
6. **Static (class 0) Data:** (object 60, variation 01) Used to represent all binary inputs, demand metering, target and control information, and counters. All points in the M-3311A relay are of static type, meaning that an integrity poll will dump all data to the querying RTU.

### Communication Ports

The relay has both front and rear panel RS-232 ports and a rear RS-485 port. The front and rear panel RS-232 ports are 9-pin (DB9S) connector configured as DTE (Data Terminal Equipment) per the EIA-232D standard. Signals are defined in Table B-1, Communication Port Signals .

The 2-wire RS-485 port is assigned to the rear panel terminal block pins 3 (-) and 4 (+).

Each communication port may be configured to operate at any of the standard baud rates (300, 600, 1200, 2400, 4800, and 9600). The RS-485 port shares the same baud rate with COM 2 (for COM1 see Section 5.4, Circuit Board Switches and Jumpers).

While the digital communication ports do include some ESD (Electrostatic Discharge) protection circuitry, they are excluded from passing ANSI/IEEE C37.90.1-1989. Beckwith Electric recommends the use of RS-232/485 to fiber optic converters to avoid any question of surge-withstand capability or ground potential rise.

A null modem cable is also shown in Figure B-1, Null Modem Cable: M-0423, if direct connection to a PC (personal computer) is desired.

CIRCUIT		SIGNAL	COM 1	COM 2
BB	RX	Receive Data	Pin 2	Pin 2
BA	TX	Transmit Data	Pin 3	Pin 3
CA	RTS	Request to Send	Pin 7	Pin 7
CB	CTS	Clear to Send		Pin 8
CD	DTR	Data Terminal Ready	Pin 4	Pin 4
CF	DCD	Data Carrier Detect		Pin 1
AB	GND	Signal Ground	Pin 5	Pin 5
		+15 V		Pin 1*
		-15 V		Pin 9*
		IRIG-B (+)		Pin 6*

\*OPTIONAL - see Section 5.5, Circuit Board Switches and Jumpers  
 ±15V (±15%) @100 mA max.

Table B-1 Communication Port Signals

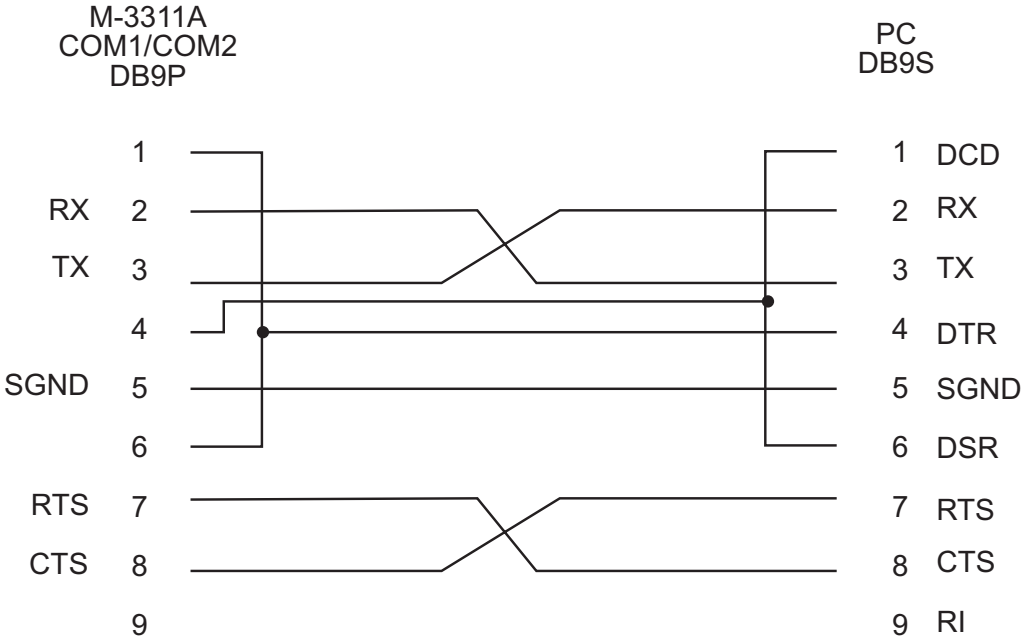

Figure B-1 Null Modem Cable for M-3311A

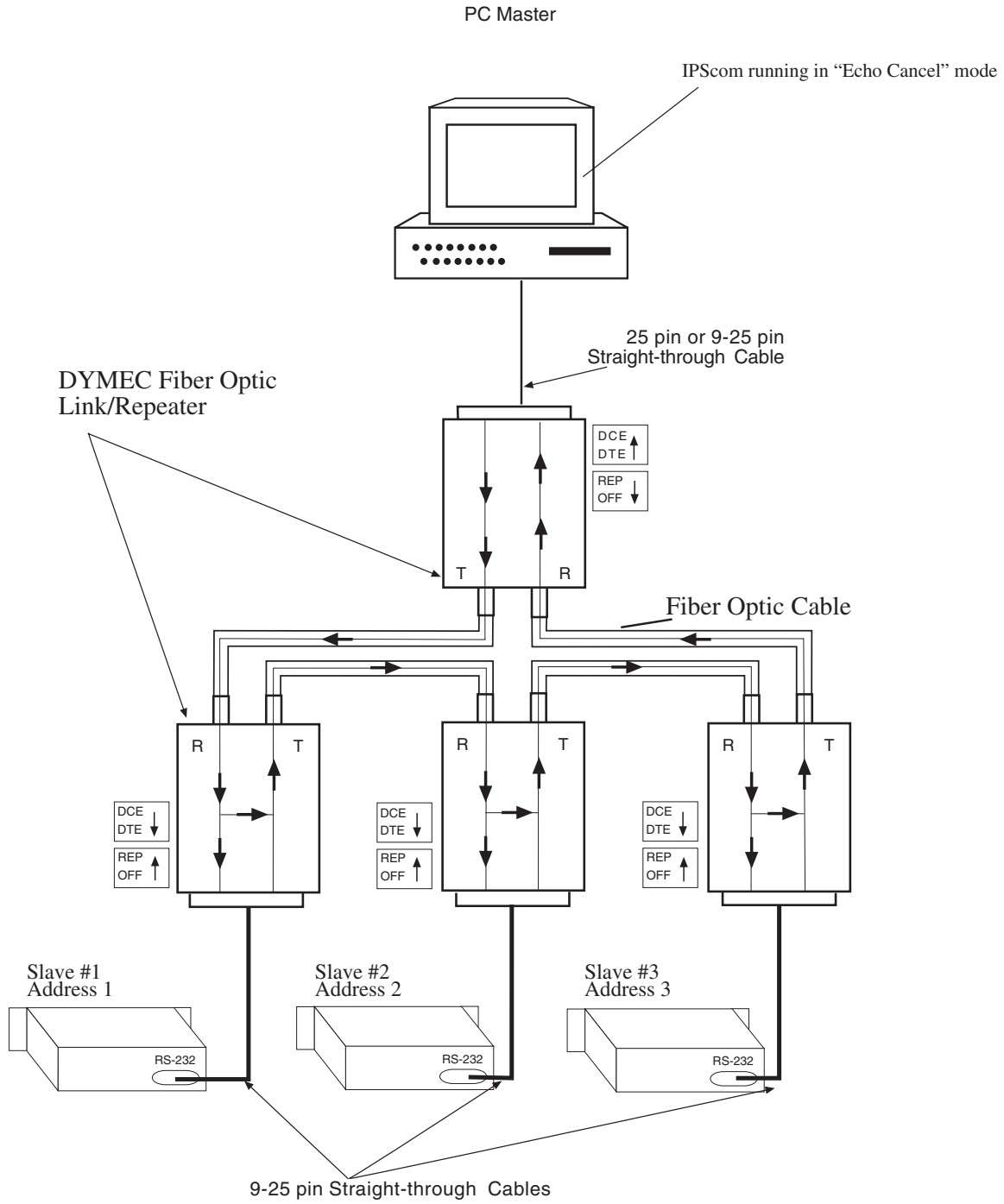
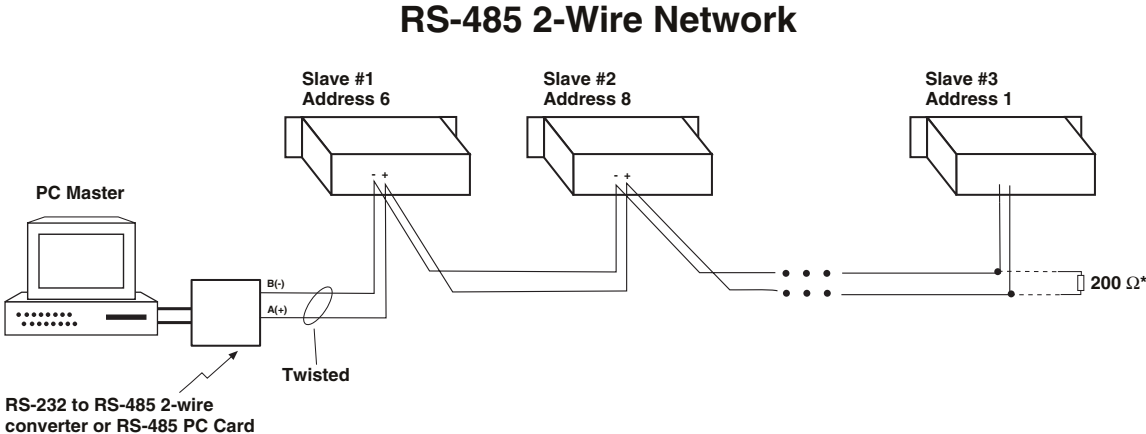

Figure B-2 RS-232 Fiber Optic Network



▲ **CAUTION:** Due to the possibility of ground potential difference between units, all units should be mounted in the same rack. If this is not possible, fiber optics with the appropriate converters should be used for isolation.

■ **NOTE:** Each address on the network must be unique. Only the last physical slave on the network should have the termination resistor installed. This may be completed externally or using a dip jumper internal to the unit. See Section 5.5, Circuit Board Switches and Jumpers.

Figure B-3 RS-485 Network

**This Page Left Intentionally Blank**

# C Appendix – Error Codes

Error Code	Description
1	
2	Battery backed RAM test fail
3	EEPROM write powerup fail
4	EEPROM read back powerup fail
5	Dual port RAM test fail
6	EEPROM write calibration checksum fail
7	EEPROM write setpoint checksum fail loss of power
8	EEPROM write setpoint checksum fail loss of battery backed RAM
9	DMA checksum/physical block fail
10	Oscillograph Memory Test Fail
11	DSP external program RAM fail
12	DSP A/D convert fail
13	DSP ground channel fail
14	DSP reference channel fail
15	DSP PGA gain fail
16	DSP DSP <-> Host interrupt 1 fail
17	DSP DSP -> Host interrupt 2 set fail
18	DSP DSP -> Host interrupt 2 reset fail
19	DSP program load fail
20	DSP no running run mode code
21	DSP not running primary boot code
22	DSP DPRAM pattern test fail
23	EEPROM write verify error

*Table C-1 Self-Test Error Codes (page 1 of 2)*

Error Code	Description
26	WARNING calibration checksum mismatch warning
27	WARNING setpoint checksum mismatch warning
28	WARNING low battery (BDRAM) warning
30	External DSP RAM test fail
31	Unrecognized INT1 code
32	Values update watchdog fail
34	Restart Error
35	Interrupt Error
36	Trap Error
37	Calibration running check fail
38	Ethernet Board Not Running (WARNING)
40	Interrupt noise INT2
44	Oscilloscope buffer overflow
45	Oscilloscope buffer underflow
46	Failure of DSP to calculate calibration phasors
50	Stack overflow
51	Setpoint write overflow

*Table C-1 Self-Test Error Codes (page 2 of 2)*

# D Appendix – Inverse Time Curves

This Appendix contains three sets of Inverse Time Curve Families. The first set is used for Volts per Hertz functions (Figures D-1 through D-4), the second set is for the M-3311A functions which utilize the IEC time over current curves (Figures D-5 through D-12) and the third set is for those functions

that utilize the IEEE Inverse Time Overcurrent Curves (Figures D-13 through D-15).

■ **Note:** Figures D-1 through D-4 are Volts per Hertz curves. Figures D-5 through D-12 are inverse time curves for 51, 51N, 51G and 46 functions.

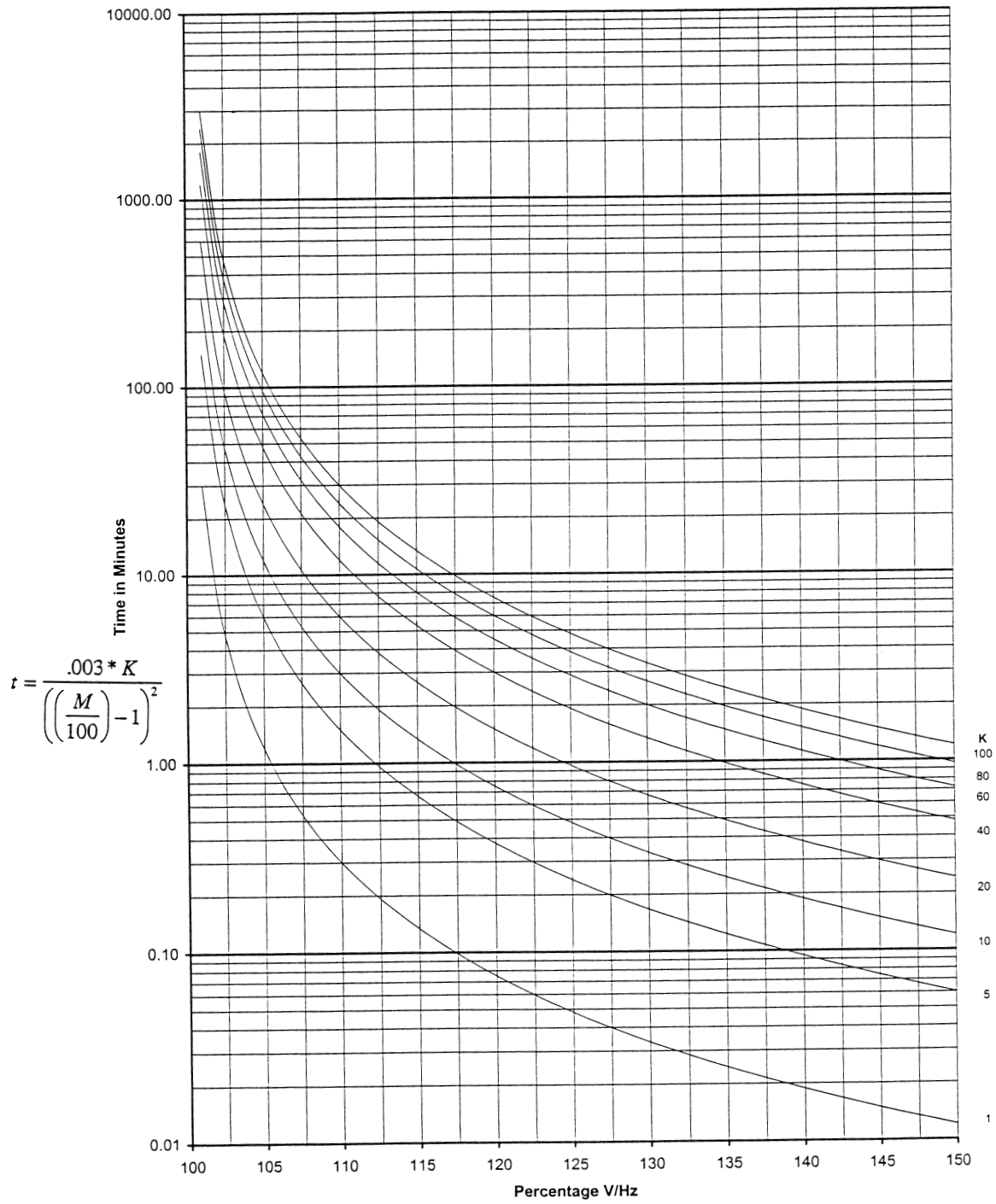

Figure D-1 Volts/Hz (24IT) Inverse Curve Family #1 (Inverse Square)

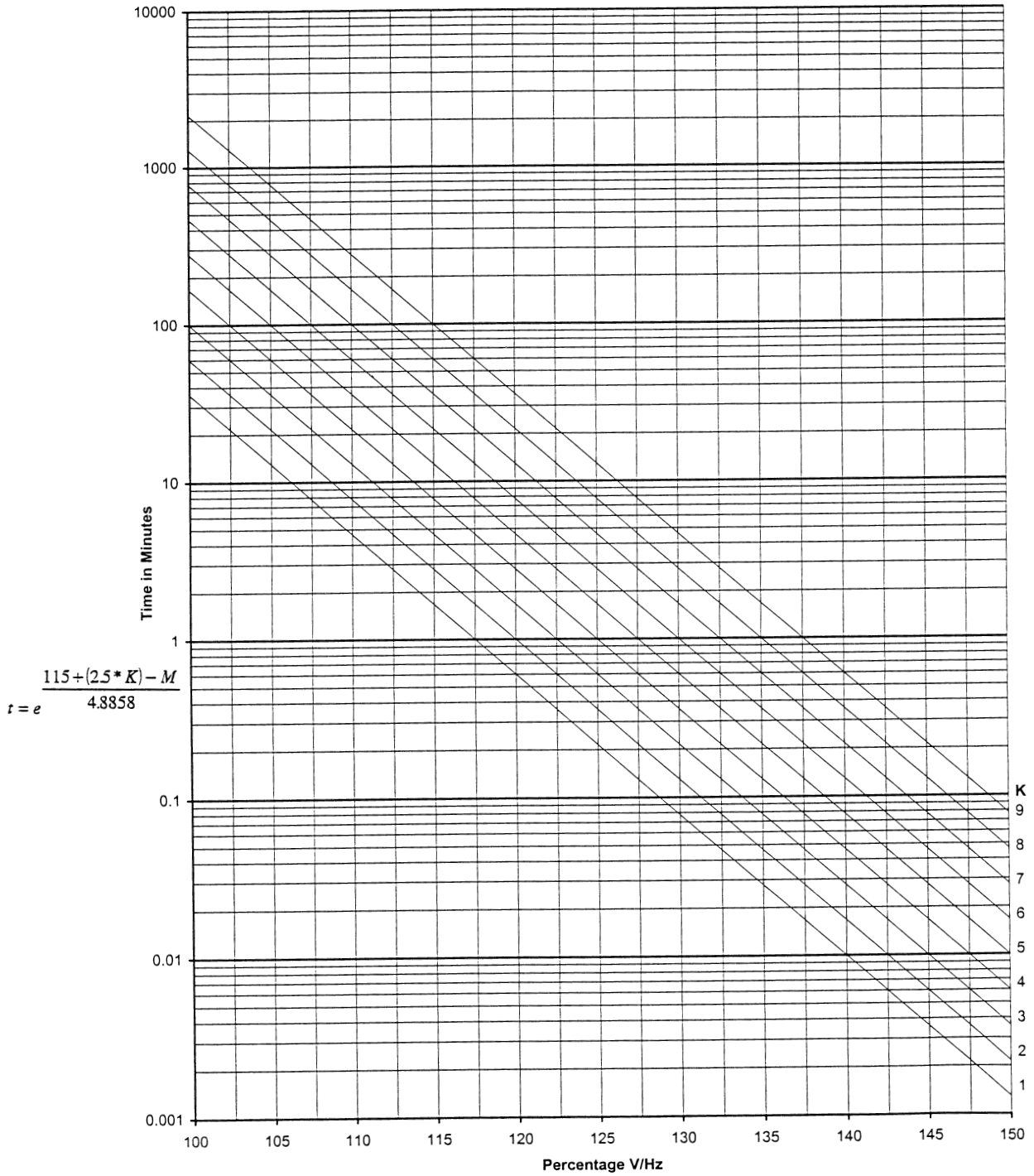

Figure D-2 Volts/Hz (24IT) Inverse Family Curve #2

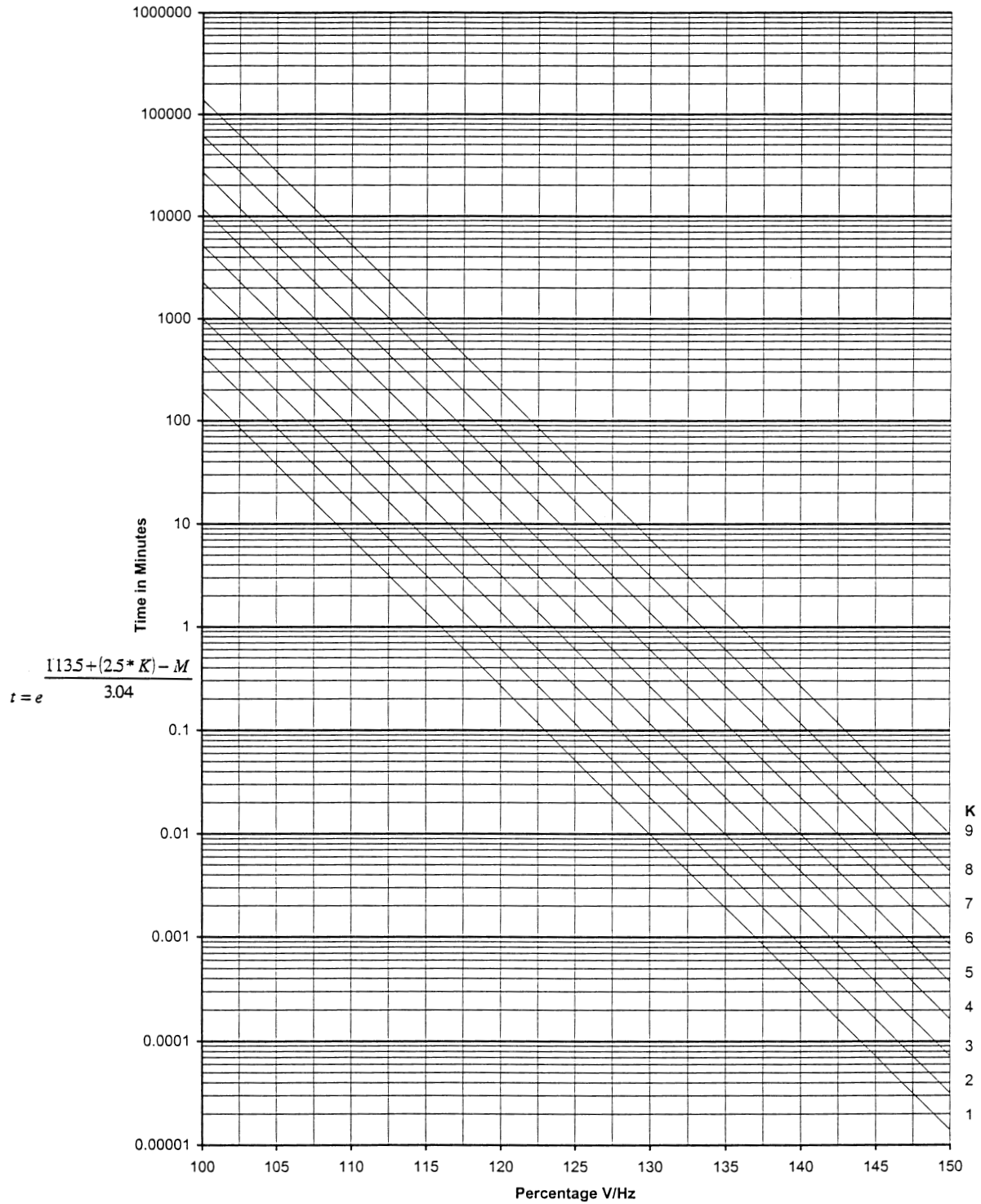

Figure D-3 Volts/Hz (24IT) Inverse Time Curve Family #3

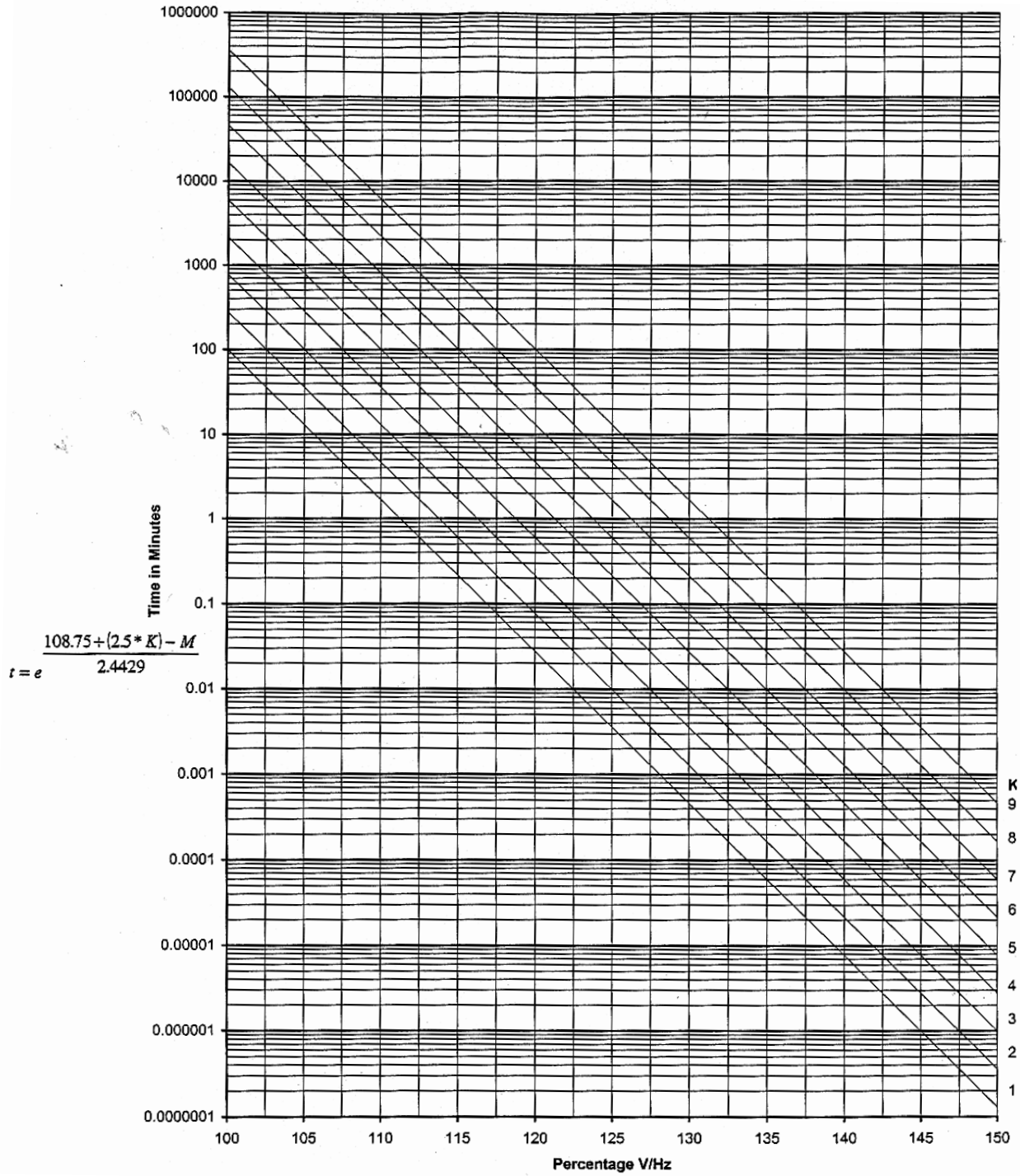

Figure D-4 Volts/Hz (24IT) Inverse Curve Family #4

Multiple of Tap Setting	Definite Time	Inverse Time	Very Inverse Time	Extremely Inverse Time
1.50	0.69899	4.53954	3.46578	4.83520
1.55	0.64862	4.15533	3.11203	4.28747
1.60	0.60539	3.81903	2.81228	3.83562
1.65	0.56803	3.52265	2.55654	3.45706
1.70	0.53558	3.25987	2.33607	3.13573
1.75	0.50725	3.02558	2.14431	2.85994
1.80	0.48245	2.81566	1.97620	2.62094
1.85	0.46068	2.62673	1.82779	2.41208
1.90	0.44156	2.45599	1.69597	2.22822
1.95	0.42477	2.30111	1.57823	2.06529
2.00	0.41006	2.16013	1.47254	1.92006
2.05	0.39721	2.03139	1.37723	1.78994
2.10	0.38606	1.91348	1.29093	1.67278
2.15	0.37648	1.80519	1.21249	1.56686
2.20	0.36554	1.72257	1.12812	1.47820
2.30	0.35293	1.54094	1.01626	1.32268
2.40	0.34115	1.39104	0.92207	1.19250
2.50	0.33018	1.26561	0.84190	1.08221
2.60	0.31999	1.15945	0.77301	0.98780
2.70	0.31057	1.06871	0.71334	0.90626
2.80	0.30189	0.99049	0.66127	0.83527
2.90	0.29392	0.92258	0.61554	0.77303
3.00	0.28666	0.86325	0.57515	0.71811
3.10	0.28007	0.81113	0.53930	0.66939
3.20	0.27415	0.76514	0.50733	0.62593
3.30	0.26889	0.72439	0.47870	0.58700
3.40	0.26427	0.68818	0.45297	0.55196
3.50	0.26030	0.65591	0.42977	0.52032
3.60	0.25697	0.62710	0.40879	0.49163
3.70	0.25429	0.60135	0.38977	0.46554
3.80	0.25229	0.57832	0.37248	0.44175
4.00	0.24975	0.53904	0.34102	0.40129
4.20	0.24572	0.50641	0.31528	0.36564
4.40	0.24197	0.47746	0.29332	0.33460
4.60	0.23852	0.45176	0.27453	0.30741
4.80	0.23541	0.42894	0.25841	0.28346

**NOTE:** The above times are in seconds and are given for a time dial of 1.0. For other time dial values, multiply the above by the time dial value.

Table D-1A M-3311 Inverse Time Overcurrent Relay Characteristic Curves

Multiple of Tap Setting	Definite Time	Inverse Time	Very Inverse Time	Extremely Inverse Time
5.00	0.23266	0.40871	0.24456	0.26227
5.20	0.23029	0.39078	0.23269	0.24343
5.40	0.22834	0.37495	0.22254	0.22660
5.60	0.22684	0.36102	0.21394	0.21151
5.80	0.22583	0.34884	0.20673	0.19793
6.00	0.22534	0.33828	0.20081	0.18567
6.20	0.22526	0.32771	0.19511	0.17531
6.40	0.22492	0.31939	0.19044	0.16586
6.60	0.22360	0.31150	0.18602	0.15731
6.80	0.22230	0.30402	0.18187	0.14957
7.00	0.22102	0.29695	0.17797	0.14253
7.20	0.21977	0.29027	0.17431	0.13611
7.40	0.21855	0.28398	0.17090	0.13027
7.60	0.21736	0.27807	0.16773	0.12492
7.80	0.21621	0.27253	0.16479	0.12003
8.00	0.21510	0.26734	0.16209	0.11555
8.20	0.21403	0.26251	0.15961	0.11144
8.40	0.21300	0.25803	0.15736	0.10768
8.60	0.21203	0.25388	0.15534	0.10422
8.80	0.21111	0.25007	0.15354	0.10105
9.00	0.21025	0.24660	0.15197	0.09814
9.50	0.20813	0.23935	0.14770	0.09070
10.00	0.20740	0.23422	0.14473	0.08474
10.50	0.20667	0.22923	0.14180	0.07943
11.00	0.20594	0.22442	0.13894	0.07469
11.50	0.20521	0.21979	0.13615	0.07046
12.00	0.20449	0.21536	0.13345	0.06667
12.50	0.20378	0.21115	0.13084	0.06329
13.00	0.20310	0.20716	0.12833	0.06026
13.50	0.20243	0.20341	0.12593	0.05755
14.00	0.20179	0.19991	0.12364	0.05513
14.50	0.20119	0.19666	0.12146	0.05297
15.00	0.20062	0.19367	0.11941	0.05104
15.50	0.20009	0.19095	0.11747	0.04934
16.00	0.19961	0.18851	0.11566	0.04784
16.50	0.19918	0.18635	0.11398	0.04652
17.00	0.19881	0.18449	0.11243	0.04539
17.50	0.19851	0.18294	0.11102	0.04442
18.00	0.19827	0.18171	0.10974	0.04362
18.50	0.19811	0.18082	0.10861	0.04298
19.00	0.19803	0.18029	0.10762	0.04250
19.50	0.19803	0.18014	0.10679	0.04219
20.00	0.19803	0.18014	0.10611	0.04205

■ **NOTE:** The above times are in seconds and are given for a time dial of 1.0. For other time dial values, multiply the above by the time dial value.

Table D-1B M-3311 Inverse Time Overcurrent Relay Characteristic Curves

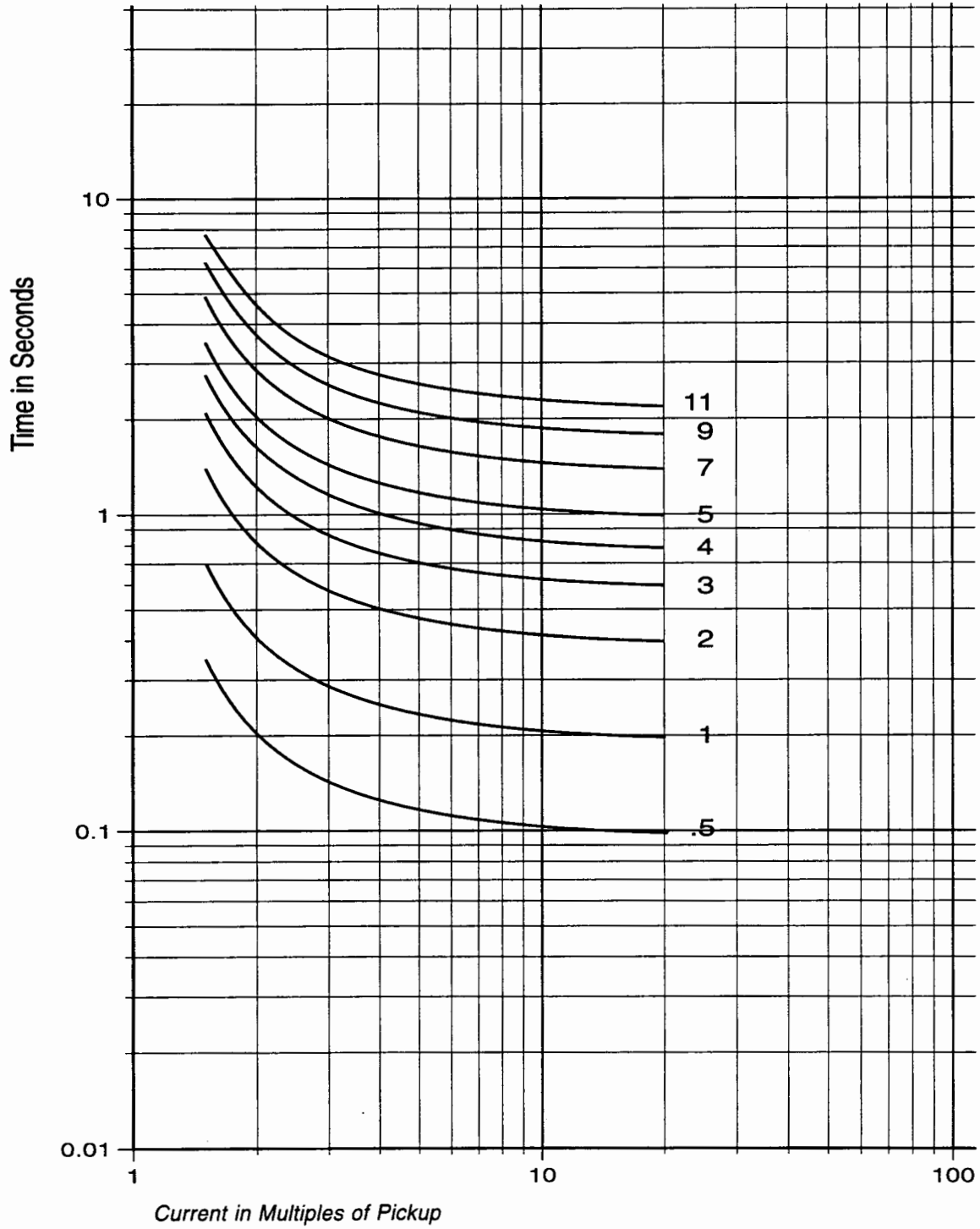

Figure D-5 Definite Time Overcurrent Curve

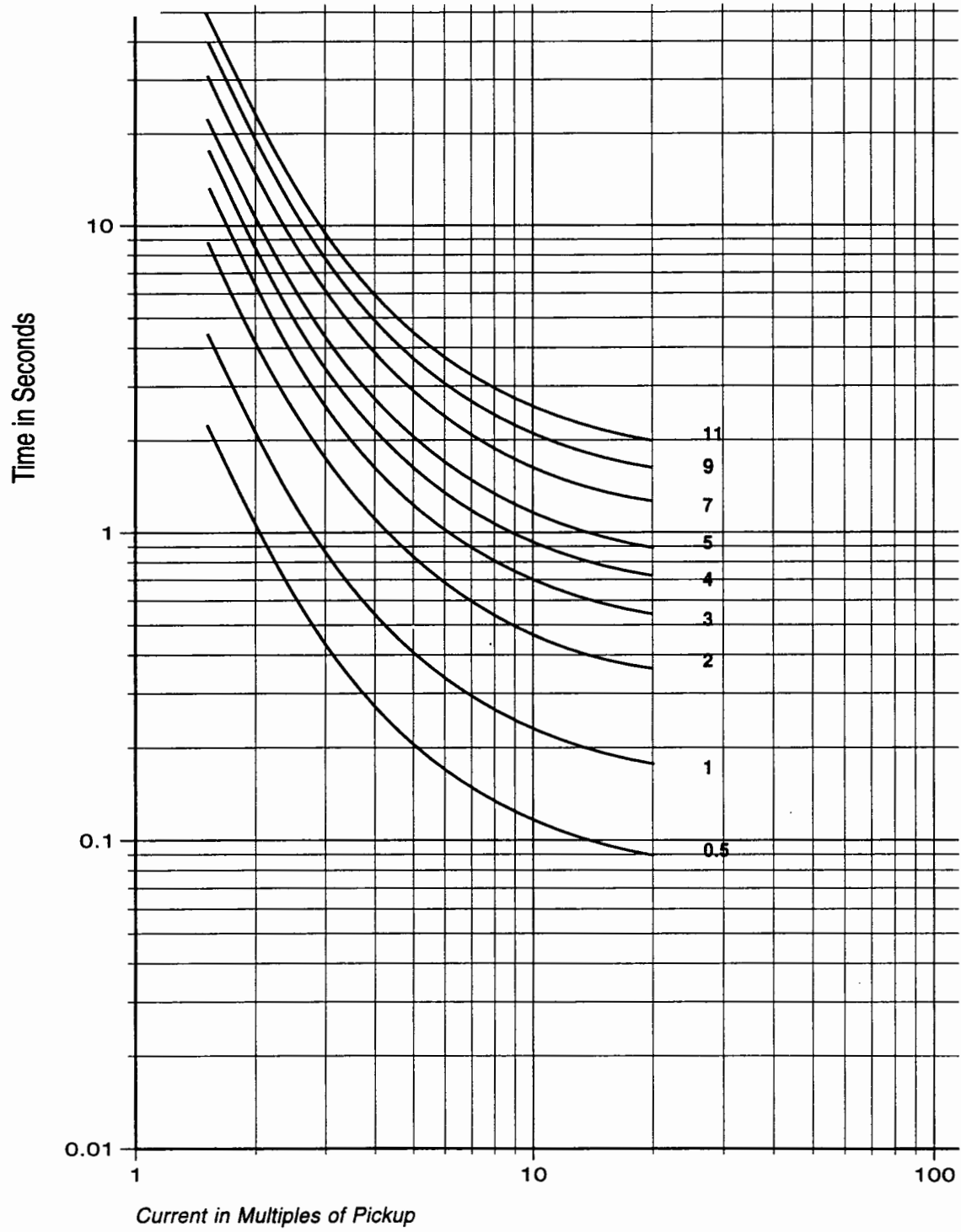

Figure D-6 Inverse Time Overcurrent Curve

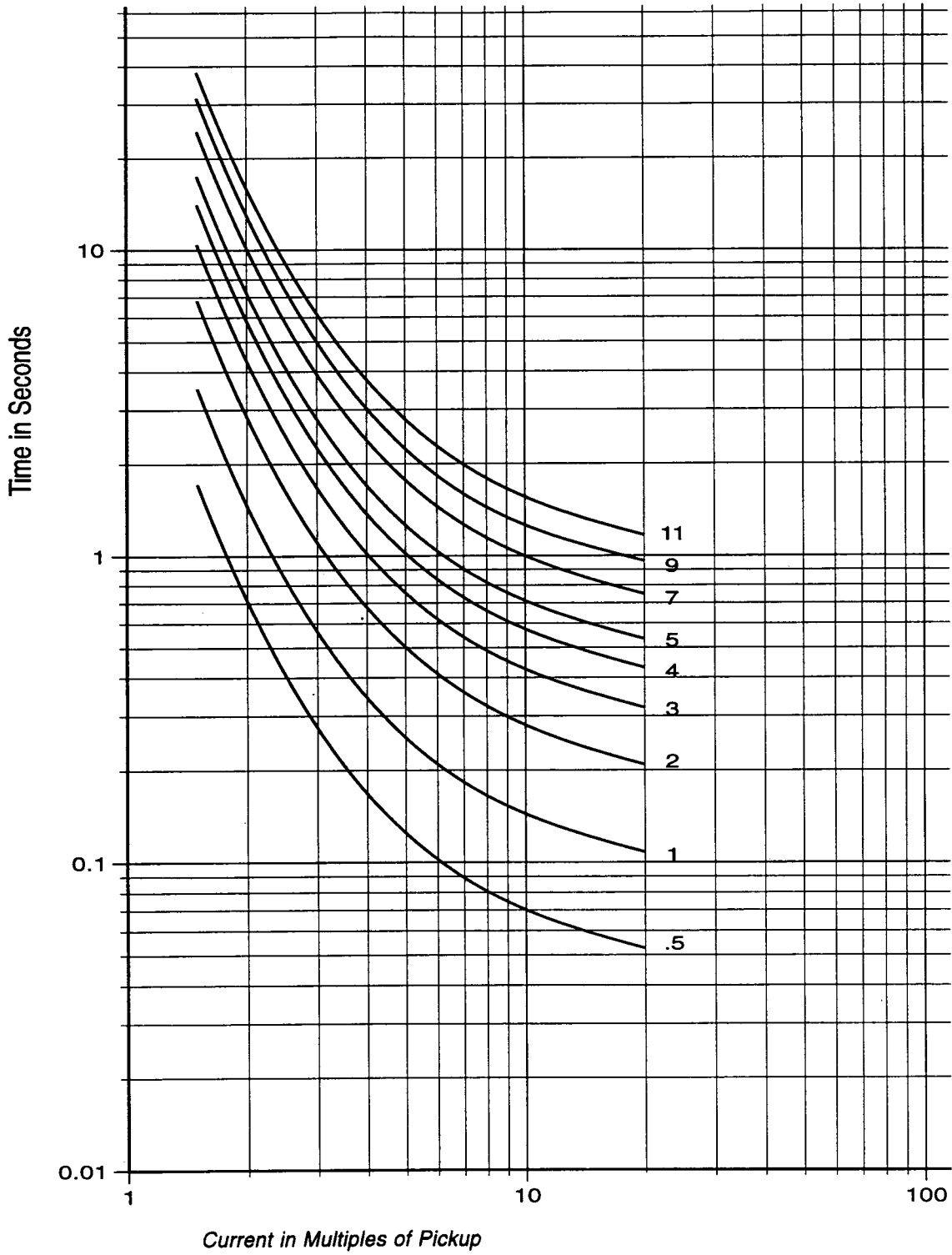

Figure D-7 Very Inverse Time Overcurrent Curve

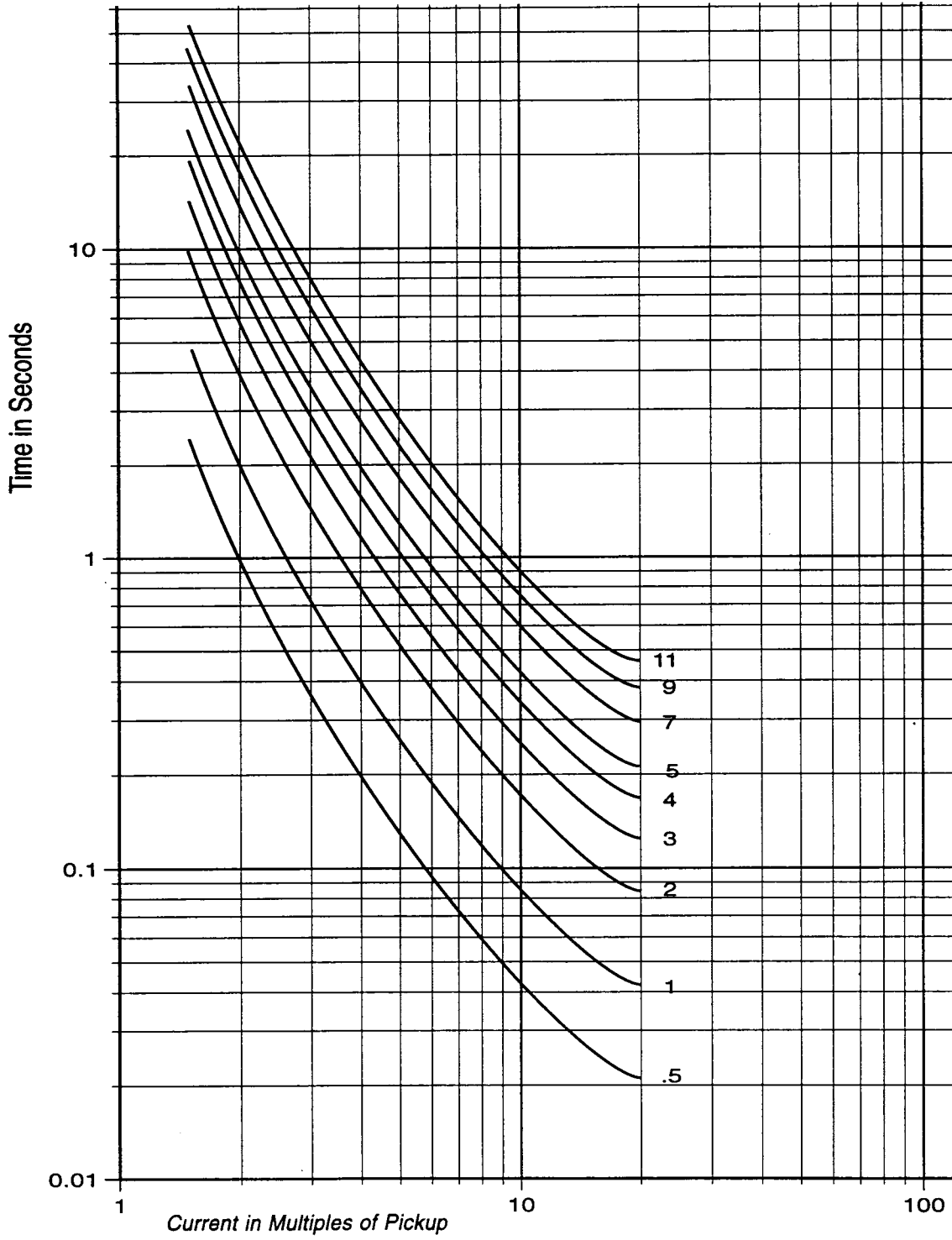
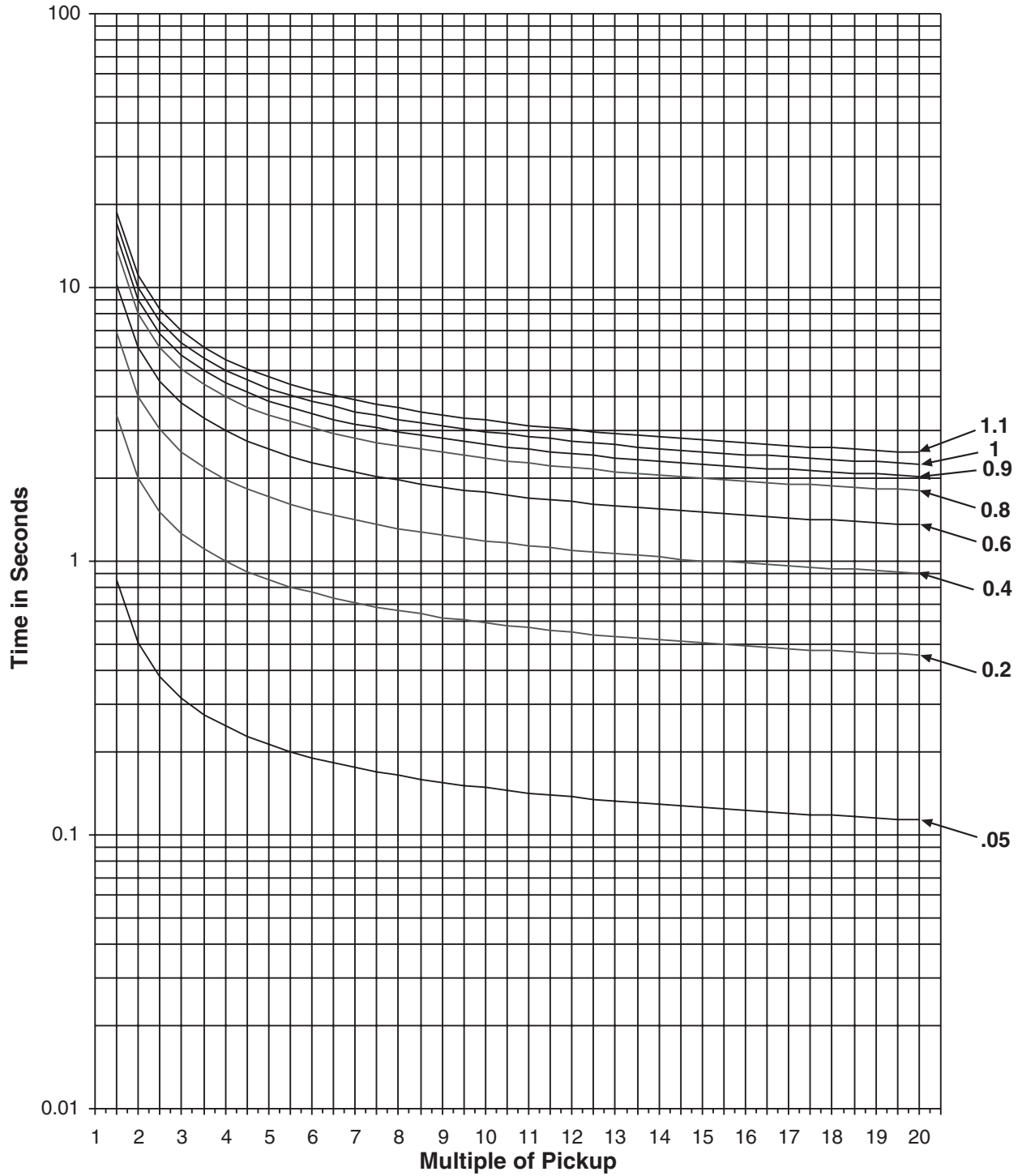
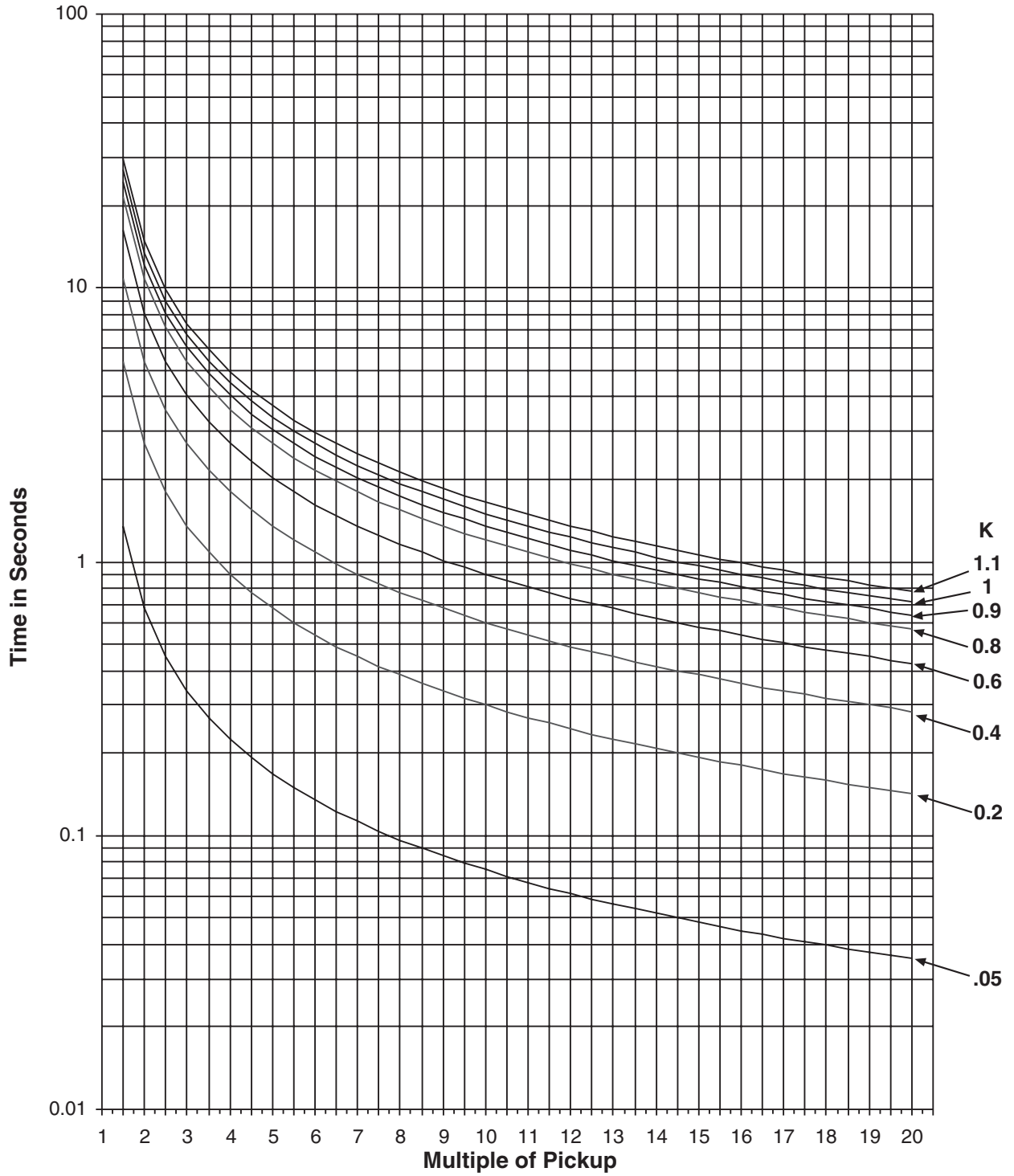

Figure D-8 Extremely Inverse Time Overcurrent Curve



$$t = TD \times \left[ \frac{0.14}{M^{0.02} - 1} \right]$$

Figure D-9 IEC Curve #1 Inverse



$$t = TD \times \left[ \frac{13.5}{M - 1} \right]$$

Figure D-10 IEC Curve #2 Very Inverse

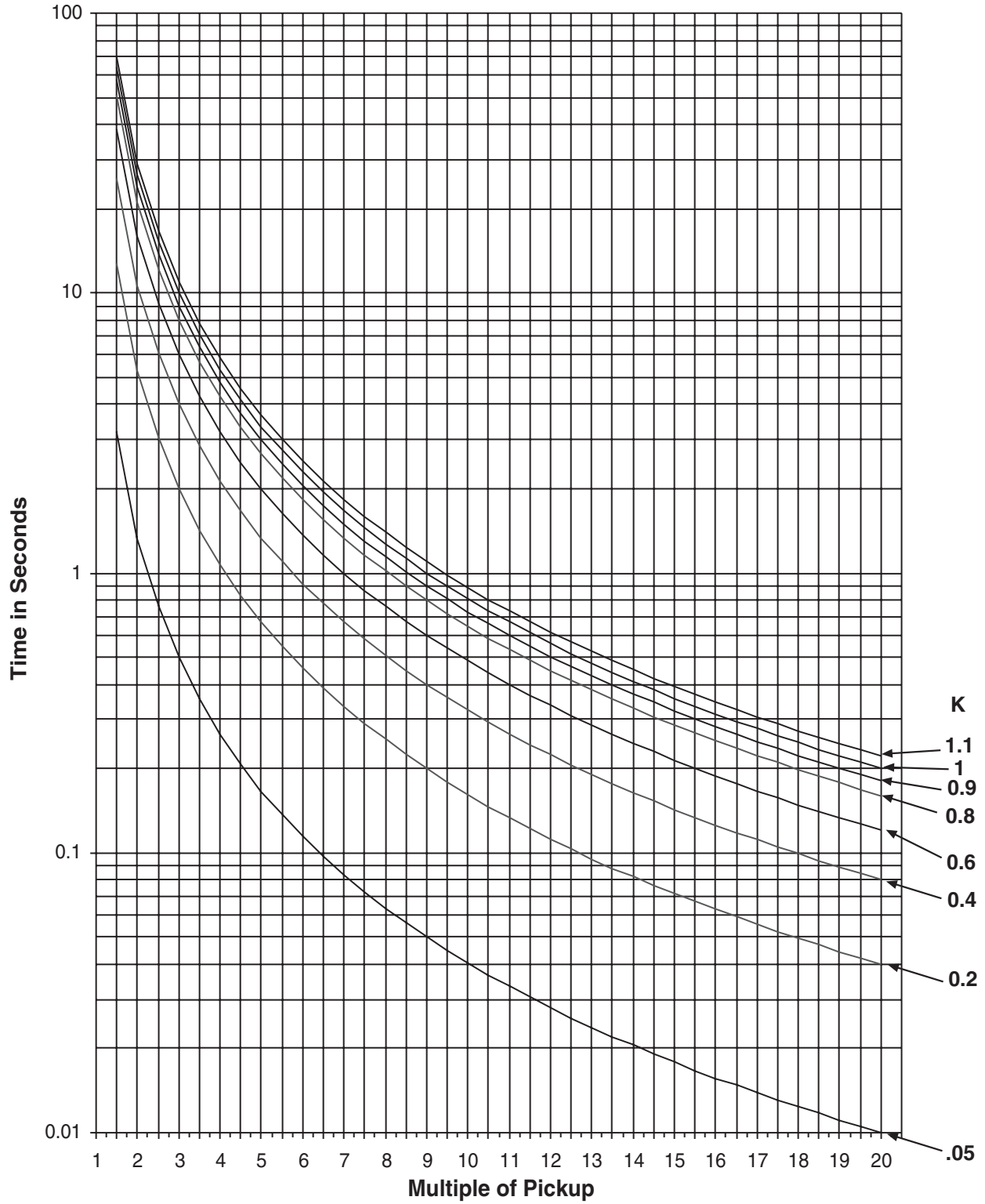

$$t = TD \times \left[ \frac{80}{M^2 - 1} \right]$$

Figure D-11 IEC Curve #3 Extremely Inverse

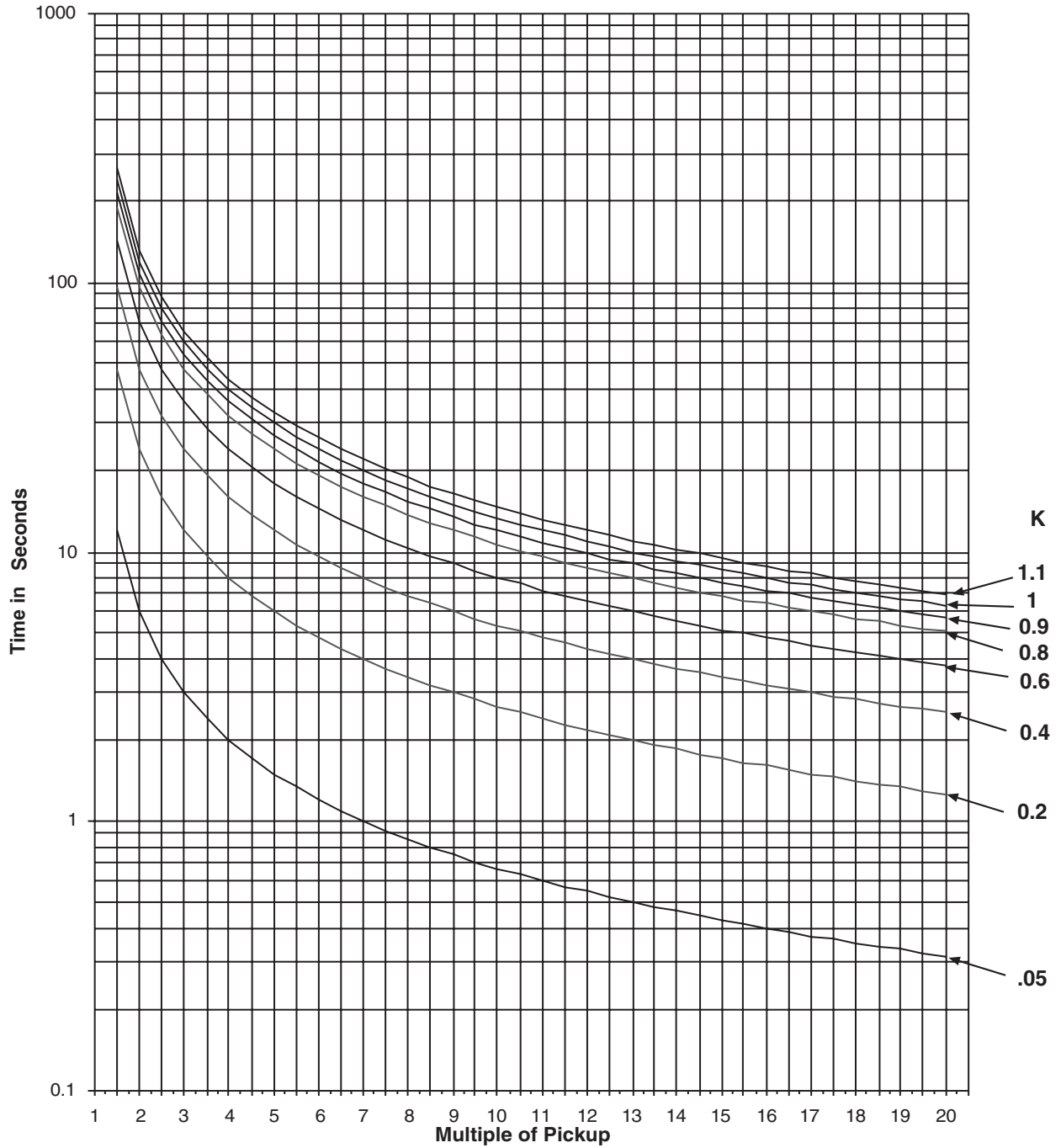

$$t = TD \times \left[ \frac{120}{M - 1} \right]$$

Figure D-12 IEC Curve #4 Long-Time Inverse

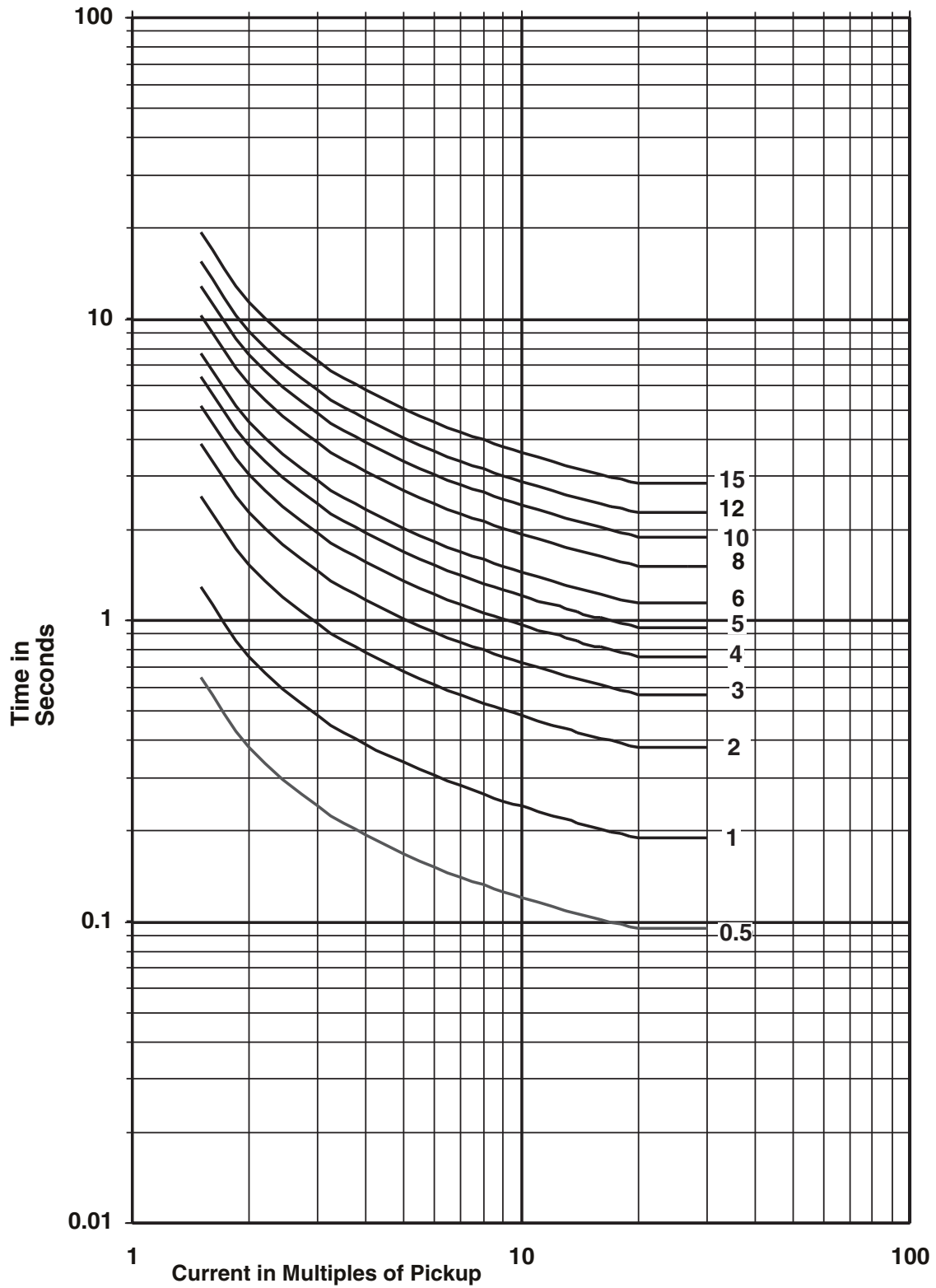

Figure D-13 IEEE (Moderately) Inverse Time Overcurrent Curves

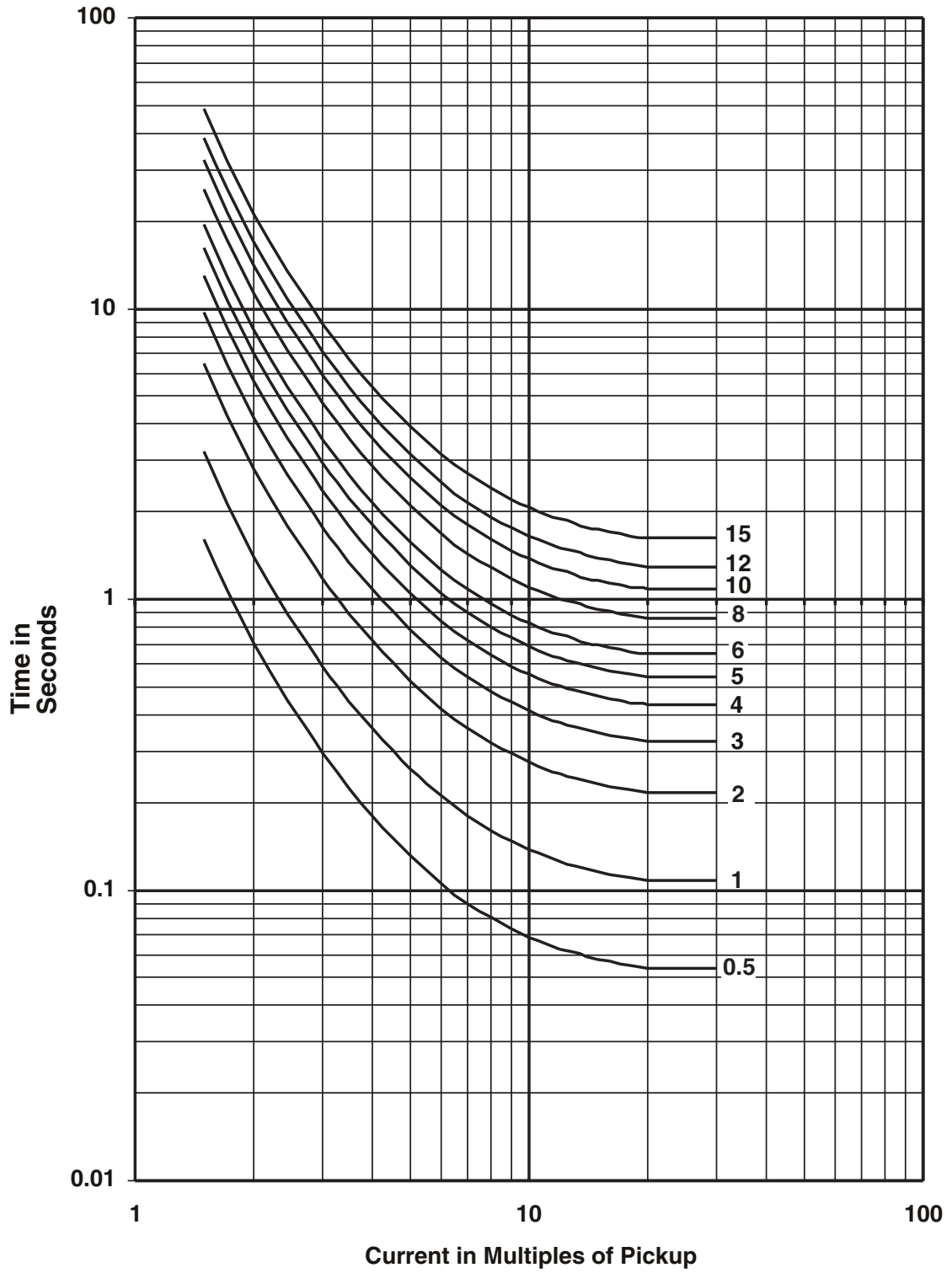

Figure D-14 IEEE Very Inverse Time Overcurrent Curves

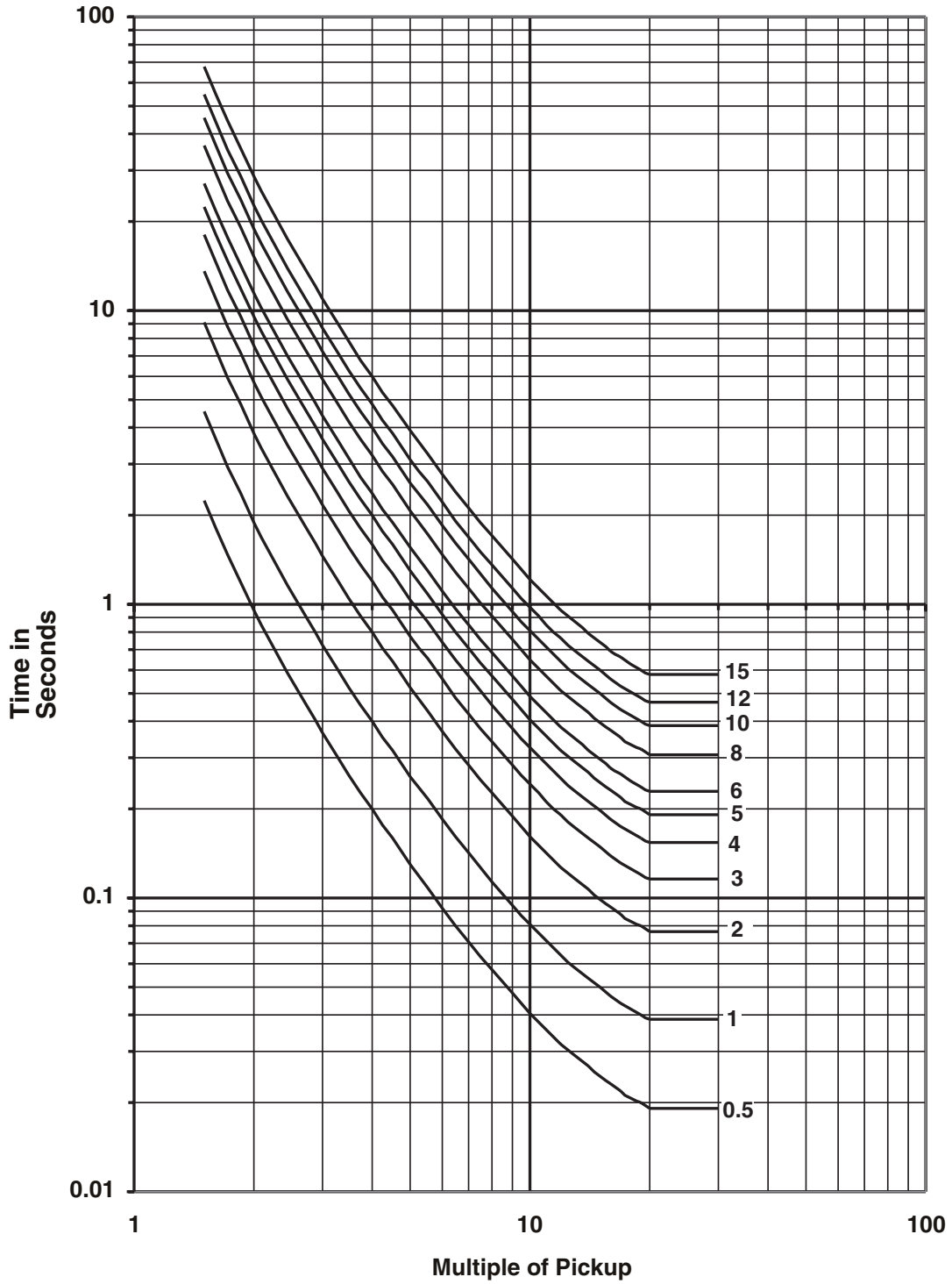

Figure D-15 IEEE Extremely Inverse Time Overcurrent Curves

# E Appendix – Layup and Storage

Appendix E includes the recommended storage parameters, periodic surveillance activities and layup configuration for the M-3311A Transformer Protection Relay

## Storage Requirements (Environment)

The recommended storage environment parameters for the M-3311A are:

- The ambient temperature where the M-3311A is stored is within a range of 5° C to 40° C
- The maximum relative humidity is less than or equal to 80% for temperatures up to 31° C, decreasing to 31° C linearly to 50% for relative humidity at 40° C.
- The storage area environment is free of dust, corrosive gases, flammable materials, dew, percolating water, rain and solar radiation.

## Storage Requirements (Periodic Surveillance During Storage)

The M-3311A power supply contains electrolytic capacitors. It is recommended that power be applied to the relay (PS1 and optional PS2 redundant power supply when installed) every three to five years for a period of not less than one hour to help prevent the electrolytic capacitors from drying out.

## Layup Configuration

The M-3311A includes a removable lithium battery backed TIMEKEEPER® module (Beckwith Electric component U25, Figure 5-10). The TIMEKEEPER module is the M-3311A real-time clock and also provides power to the unit's nonvolatile memory when power is not applied to the unit.

Layup of the M-3311A requires verifying that the system clock is stopped. The steps necessary to verify system clock status are as follows:

**▲ CAUTION:** Do not use the diagnostic mode in relays that are installed in an active protection scheme.

### For units *with* the optional HMI panel:

1. Verify that the Power Supply (PS) fuses are installed.
2. Determine the unit power supply rating by observing the check box below the PS terminals on the rear of the unit.
3. Apply power to the unit consistent with the rating determined in Step 2 (see Section 5.3, External Connections). The unit will enter the selftest mode.
4. When the selftests are complete, then press **ENTER** to begin main menu.
5. Press the right arrow pushbutton until **SETUP UNIT** is displayed.
6. Press **ENTER** to access the **SETUP UNIT** menu.
7. Press the right arrow pushbutton until **DIAGNOSTIC MODE** is displayed.
8. Press **ENTER**. A reset warning will be displayed:

PROCESSOR WILL RESET!  
ENTER KEY TO CONTINUE

**◆ WARNING:** All relay functions and protection will be inoperative while the relay is in diagnostic mode.

9. Press **ENTER**. Unit will now reset and **DIAGNOSTIC MODE** will be temporarily displayed, followed by **OUTPUT TEST (RELAY)**. This is the beginning of the diagnostic menu.

10. Press the right arrow pushbutton until the following is displayed:

```
CLOCK TEST
← CLOCK led cal factory
```

11. Press **ENTER**. The following is displayed:

```
CLOCK TEST
03-JAN-1998 09:00:00.000
```

12. If the clock is running, press **ENTER** to stop the clock. The following is displayed:

```
CLOCK TEST
-CLOCK STOP-
```

■ **NOTE:** When the relay clock is stopped, the seconds will be displayed as 80.

13. Press **ENTER** and verify the relay clock is stopped. A display similar to the following is shown with the seconds stopped:

```
CLOCK TEST
03-JAN-09:01:80.000
```

14. When the clock has been verified to be stopped, then press **EXIT** until the following message appears:

```
PRESS EXIT TO
EXIT DIAGNOSTIC MODE
```

15. Press **EXIT** again to exit **DIAGNOSTIC MODE**. The relay will reset and normal running mode will resume.

■ **NOTE:** Pressing any button other than **EXIT** will return the user to **DIAGNOSTIC MODE**.

16. Remove power from the unit. The unit can now be placed in storage.

**For units without the optional HMI panel:**

1. Verify that the Power Supply (PS) fuses are installed.
2. Determine the unit power supply rating by observing the check box below the PS terminals on the rear of the unit.
3. Apply power to the unit consistent with the rating determined in Step 2 (see Section 5.3, External Connections). The unit will enter the selftest mode.

4. Install M-3826 IPScom Communications Software (see Section 5.6, IPScom Communications and Analysis Software Installation) on a PC that includes the following:

- Microsoft Windows™ 98 Operating System or above
- Equipped with a serial port

5. Connect a null modem cable from COM1 of the relay to the PC serial port.
6. Open communications with the relay utilizing Section 5.7, Activating Initial Local Communications.
7. Select **Relay/Setup/Set Date & Time** from the menu bar. IPScom will display the “Setup Date/Time dialog screen Figure 3-20.
8. Verify that “Start Clock” is displayed, then proceed as follows:
  - a. If “Start Clock” is displayed, then select “Save” and go to Step 9.
  - b. If “Stop Clock” is displayed, then select “Stop Clock” and then select “Save”.
9. Close communications with the unit by selecting “Comm” from the menu bar and then select “Exit”.
10. Disconnect the null modem cable and then remove power from the unit. The unit can now be placed in storage.

Storage of the M-3311A greater than five years may require replacement of the lithium battery prior to placing the unit in service. Contact Beckwith Electric Customer Service for replacement procedure.

## Patent

The units described in this manual are covered by U.S. Patents, with other patents pending.

Buyer shall hold harmless and indemnify the Seller, its directors, officers, agents, and employees from any and all costs and expense, damage or loss, resulting from any alleged infringement of United States Letters Patent or rights accruing therefrom or trademarks, whether federal, state, or common law, arising from the Seller's compliance with Buyer's designs, specifications, or instructions.

## Warranty

Seller hereby warrants that the goods which are the subject matter of this contract will be manufactured in a good workmanlike manner and all materials used herein will be new and reasonably suitable for the equipment. Seller warrants that if, during a period of five years from date of shipment of the equipment, the equipment rendered shall be found by the Buyer to be faulty or shall fail to perform in accordance with Seller's specifications of the product, Seller shall at his expense correct the same, provided, however, that Buyers shall ship the equipment prepaid to Seller's facility. The Seller's responsibility hereunder shall be limited to replacement value of the equipment furnished under this contract.

*Seller makes no warranties expressed or implied other than those set out above. Seller specifically excludes the implied warranties of merchantability and fitness for a particular purpose. There are no warranties which extend beyond the description contained herein. In no event shall Seller be liable for consequential, exemplary, or punitive damages of whatever nature.*

Any equipment returned for repair must be sent with transportation charges prepaid. The equipment must remain the property of the Buyer. The aforementioned warranties are void if the value of the unit is invoiced to the Seller at the time of return.

## Indemnification

The Seller shall not be liable for any property damages whatsoever or for any loss or damage arising out of, connected with, or resulting from this contract, or from the performance or breach thereof, or from all services covered by or furnished under this contract.

In no event shall the Seller be liable for special, incidental, exemplary, or consequential damages, including but not limited to, loss of profits or revenue, loss of use of the equipment or any associated equipment, cost of capital, cost of purchased power, cost of substitute equipment, facilities or services, downtime costs, or claims or damages of customers or employees of the Buyer for such damages, regardless of whether said claim or damages is based on contract, warranty, tort including negligence, or otherwise.

Under no circumstances shall the Seller be liable for any personal injury whatsoever.

It is agreed that when the equipment furnished hereunder are to be used or performed in connection with any nuclear installation, facility, or activity, Seller shall have no liability for any nuclear damage, personal injury, property damage, or nuclear contamination to any property located at or near the site of the nuclear facility. Buyer agrees to indemnify and hold harmless the Seller against any and all liability associated therewith whatsoever whether based on contract, tort, or otherwise. Nuclear installation or facility means any nuclear reactor and includes the site on which any of the foregoing is located, all operations conducted on such site, and all premises used for such operations.

## Notice:

Any illustrations and descriptions by Beckwith Electric Co., Inc. are for the sole purpose of identification.

The drawings and/or specifications enclosed herein are the proprietary property of Beckwith Electric Co., Inc., and are issued in strict confidence; therefore, shall not be used as a basis of reproduction of the apparatus described therein without written permission of Beckwith Electric Co., Inc.

No illustration or description contained herein shall be construed as an express warranty of affirmation, promise, description, or sample, and any and all such express warranties are specifically excluded nor shall such illustration or description imply a warranty that the product is merchantable or fit for a particular purpose. There shall be no warranties which extend beyond those contained in the Beckwith Electric Co., Inc. terms of sale.



**BECKWITH ELECTRIC CO., INC.**

6190 - 118th Avenue North • Largo, Florida 33773-3724 U.S.A.

PHONE (727) 544-2326 • FAX (727) 546-0121

E-MAIL [marketing@beckwithelectric.com](mailto:marketing@beckwithelectric.com)

WEB PAGE [www.beckwithelectric.com](http://www.beckwithelectric.com)