

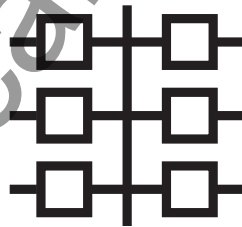

B-PRO

Bus Protection Relay

Model 8700/BUS



User Manual

Version 2.1 Rev 2

www.ElectricalPartManuals.com

Preface

Information in this document is subject to change without notice.

© 2008 ERLPhase Power Technologies Ltd. All rights reserved.

Reproduction in any manner whatsoever without the written permission of ERLPhase Power Technologies Ltd. is strictly forbidden.

This manual is part of a complete set of product documentation that includes detailed drawings and operation. Users should evaluate the information in the context of the complete set of product documentation and their particular applications. ERLPhase assumes no liability for any incidental, indirect, or consequential damages arising from the use of this documentation.

While all information presented is believed to be reliable and in accordance with accepted engineering practices, ERLPhase makes no warranties as to the completeness of the information.

All trademarks used in association with B-PRO, F-PRO, L-PRO, ProLogic, T-PRO, TESLA, TESLA Control Panel, RecordGraph and RecordBase are trademarks of ERLPhase Power Technologies Ltd.

Windows® is a registered trademark of the Microsoft Corporation.

Procomm® is a registered trademark of Symantec.

HyperTerminal® is a registered trademark of Hilgraeve.

Modbus® is a registered trademark of Modicon.

Contact Information

ERLPhase Power Technologies Ltd.

Website: www.erlphase.com

Email: info@erlphase.com

Technical Support

Email: support@erlphase.com

Tel: 204-477-0591

www.ElectricalPartManuals.com

Version Compatibility and Release History

This chart indicates the versions of *Offliner* Settings, RecordBase View and the User Manual which are compatible with different versions of B-PRO firmware.

RecordBase View and *Offliner* Settings are backward compatible with all earlier versions of records and setting files. You can use RecordBase View to view records produced by any version of B-PRO firmware and *Offliner* Settings can create and edit older setting file versions.

Minor releases (designated with a letter suffix - e.g. v1.1a) maintain the same compatibility as their base version. For example, B-PRO firmware v1.1b and *Offliner* Settings v1.1a are compatible.

B-PRO 8700/BUS Firmware/Software Compatibility Guide				
B-PRO Firmware	Record Version	Setting Version	Compatible <i>Offliner</i> Settings	Compatible RecordBase View
v2.1a	9	4	v2.1 or greater	v1.5d or greater
v2.1	9	4	v2.1 or greater	v1.5d or greater
v2.0	9	3	v2.0 or greater	v1.5d or greater
v1.1	9	2	v1.1 or greater	v1.4 or greater
v1.0	8	1	v1.0 or greater	v1.1 or greater

B-PRO 8700/BUS Firmware Revision History		
Date	Version	Changes from Previous Version
2007 Mar 14	v2.1a	Improved 87B security
2006 Jun 29	v2.1	Improved 87T target on wye-connected transformers Separated MVA settings for Bus 1 and Bus 2 Added invert switch on each digital control Extended transformer MVA setting range Increased external input glitch filter security Added support for a backup DNP SCADA Master
2004 Jul 30	v2.0	Added multi bus differential zones (87B-1 and 87B-2). Added 30 virtual inputs for SCADA controls. Added swing recording. Added IO and IR recording to 87T. Extended Bus MVA setting range.
2004 May 5	v1.1c	Corrected SCADA protocol errors
2004 Mar 24	v1.1b	Improved the Self Check algorithm to detect DC offset faster. Fixed reporting of time synchronization status in records. Fixed handling of user-specified IP addresses with leading zeros.

B-PRO 8700/BUS Firmware Revision History

2003 Jan 17	v1.1a	PT Turns Ratio on the System Parameters screen expanded to allow a setting up to 10000:1.
2002 Aug 08	v1.1	Add CT saturation detector. Standardized 51 IEEE parameters, user-defined directional characteristics. Increased 81 sensitivity for minimum time delay.
2001 Mar 07	v1.0	First release.

B-PRO 8700/BUS Offliner Settings Revision History

Date	Offliner Settings Version	Changes from Previous Version
2006 Jun 29	v2.1	Separated MVA settings for Bus 1 and Bus 2 Added invert switch on each digital control Extended transformer MVA setting range
2004 Jul 30	v2.0	Added multi bus differential zones (87B-1 and 87B-2). Added 30 virtual inputs for SCADA. Added swing recording capability. Extended Bus MVA setting range.
2003 Jan 17	v1.1b	PT Turns Ratio on the System Parameters screen expanded to allow a setting up to 10000:1.
2002 Sep 18	v1.1a	Correct an error in ProLogic input list.
2002 Aug 12	v1.1	Add CT saturation detector. Standardized 51 IEEE parameters, user-defined directional characteristics.
2001 Mar 07	v1.0	First release.

B-PRO 8700/BUS User Manual Revision History

Date	Manual Version	Changes from Previous Version
2008 Feb 29	v2.1 Rev 2	Branded to ERLPhase.
2007 Mar 14	v2.1 Rev 1	Update to include firmware v2.1a support
2006 Jun 29	v2.1	Update to include firmware v2.1 support
2004 Jul 30	v2.0 Rev 1	Update to include firmware v2.0 support
2004 May 5	v1.1 Rev 5	Minor consistency improvements
2004 Mar 24	v1.1 Rev 4	Update to include firmware v1.1b support.
2003 Oct 31	v1.1 Rev 3	Updated format of manual.

B-PRO 8700/BUS User Manual Revision History

2003 Jan 17	v1.1 Rev 2	PT Turns Ratio on the System Parameters screen expanded to allow a setting up to 10000:1.
2002 Aug 12	v1.1	Update to include new functions.
2001 Aug 14	v1.0 Rev 2	Update Setup and Communications.
2001 Mar 07	v1.0	First release.

www.ElectricalPartManuals.com

Using This Guide

This user manual describes the installation and operation of the B-PRO bus protection relay user interface software. It is intended to support the first time user and clarify the details of the equipment.

The manual uses a number of conventions to denote special information:

Example	Describes
<i>Start>Settings>Control Panel</i>	Choose the Control Panel submenu in the Settings submenu on the Start menu.
Right-click	Click the right mouse button.
<i>Recordings</i>	Menu items and tabs are shown in italics.
service	User input or keystrokes are shown in bold.
Text boxes similar to this one	Relates important notes and information.
..	Indicates more screens.
▶	Indicates further drop-down menu, click to display list.
	Indicates a warning.

www.ElectricalPartManuals.com

Table of Contents

Preface	i
Contact Information	i
Version Compatibility and Release History.....	iii
Using This Guide	vii
Table of Contents	1
1 Overview	1-1
Front View	1-3
Back View.....	1-4
Model Options/Ordering	1-5
2 Setup and Communications.....	2-1
Power Supply	2-1
IRIG-B Time Input.....	2-1
Communicating with the Relay (IED).....	2-2
Using HyperTerminal to Access the Relay's User Interface.....	2-5
Setting the Baud Rate	2-6
Accessing the SCADA Services.....	2-7
Communication Port Details	2-8
Maintenance Menu	2-11
Firmware Update.....	2-12
3 Using the IED (Getting Started)	3-1
Start-up Sequence	3-1
Front Panel Display	3-2
Terminal Mode.....	3-4
Metering Data.....	3-14
4 Protection Functions	4-1
Differential Zone Selection and CT Input Assignment.....	4-1
Digital Control.....	4-1
Protection Function Descriptions.....	4-1
Recording Functions.....	4-21
Event Log	4-24
5 Offliner Settings Software	5-1
Introduction.....	5-1
Installing PC Software	5-2
Offliner Features.....	5-2
Main Branches from the Tree View	5-7
Offliner Keyboard Shortcuts	5-9
Handling Backward Compatibility	5-10

RecordBase View Software.....	5-12
6 Testing the B-PRO Functions	6-1
7 Installation	7-1
Physical Mounting	7-1
AC and DC Wiring	7-1
Communication Wiring	7-1
Appendix A IED Specifications	A-1
Appendix B IED Settings and Ranges	B-1
Appendix C Hardware Description	C-1
Appendix D Event Messages	D-1
Appendix E Modbus RTU Communication Protocol	E-1
Appendix F DNP3 Communication Protocol	F-1
Appendix G Mechanical Drawings	G-1
Appendix H Rear Panel Drawings	H-1
Appendix I AC Schematic Drawing	I-1
Appendix J DC Schematic Drawing	J-1
Appendix K Bus Differential Function Setting Examples	K-1
Appendix L Function Logic Diagram	L-1
Appendix M Analog Phase Shift Table	M-1
Appendix N How to Start the CT Saturation Calculator	N-1
Index	I
Software Installation Instructions	III

1 Overview

The B-PRO (model 8700/BUS) is a microprocessor-based relay providing bus differential protection, integrated breaker failure and overcurrent protection functions, metering, fault and swing oscillography.

B-PRO has two working modes—online and offline. In the online mode you can use any communication software package (e.g. Procomm or HyperTerminal) to connect to the B-PRO using VT100 terminal emulation. In online mode you can:

- change and review relay settings
- view event and metering information
- initiate and retrieve recordings, and retrieve settings

In offline mode you can use *Offliner* Settings and RecordBase View software to:

- create and review relay settings
- analyze fault waveforms
- store records

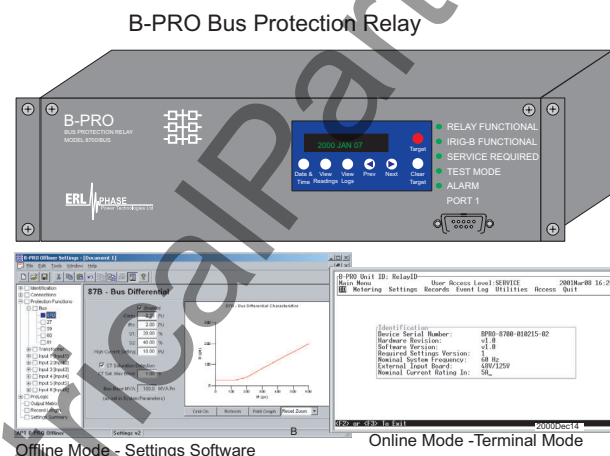

The B-PRO relay provides differential protection (low-impedance) for the following types of bus configurations:

- 1 bus with up to six inputs and one set of voltage inputs (Figure).
- 1 transformer zone with 2 inputs.
- 2 differential zones, 1 for a bus and 1 for a transformer (Figure).
- 2 bus zones (Figure 1.3).

Backup feeder protection is provided for all inputs, regardless of which zone is selected, even if an input is not used in a differential zone.

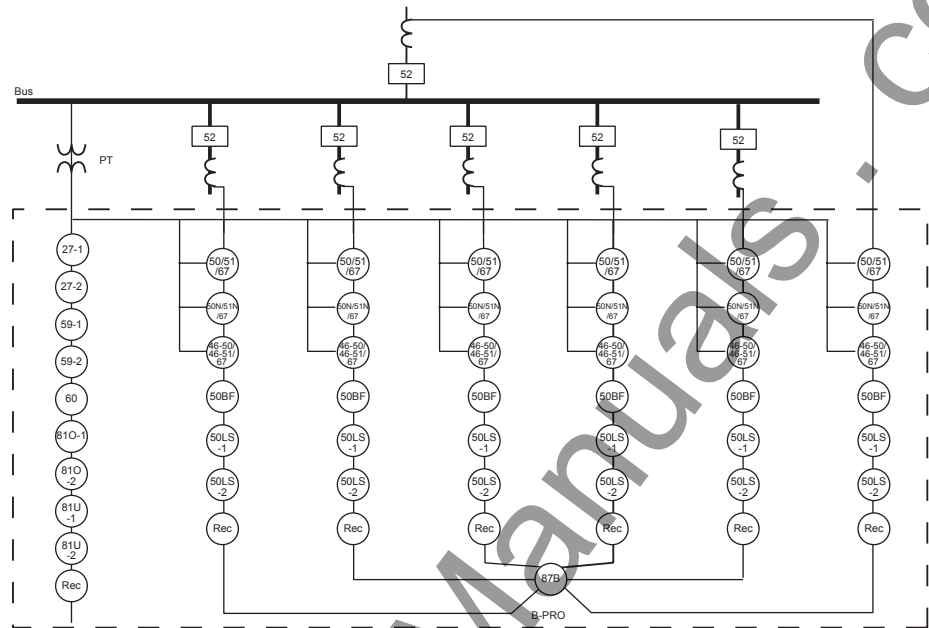

Figure 1.1: B-PRO Function Diagram (1 differential zone)

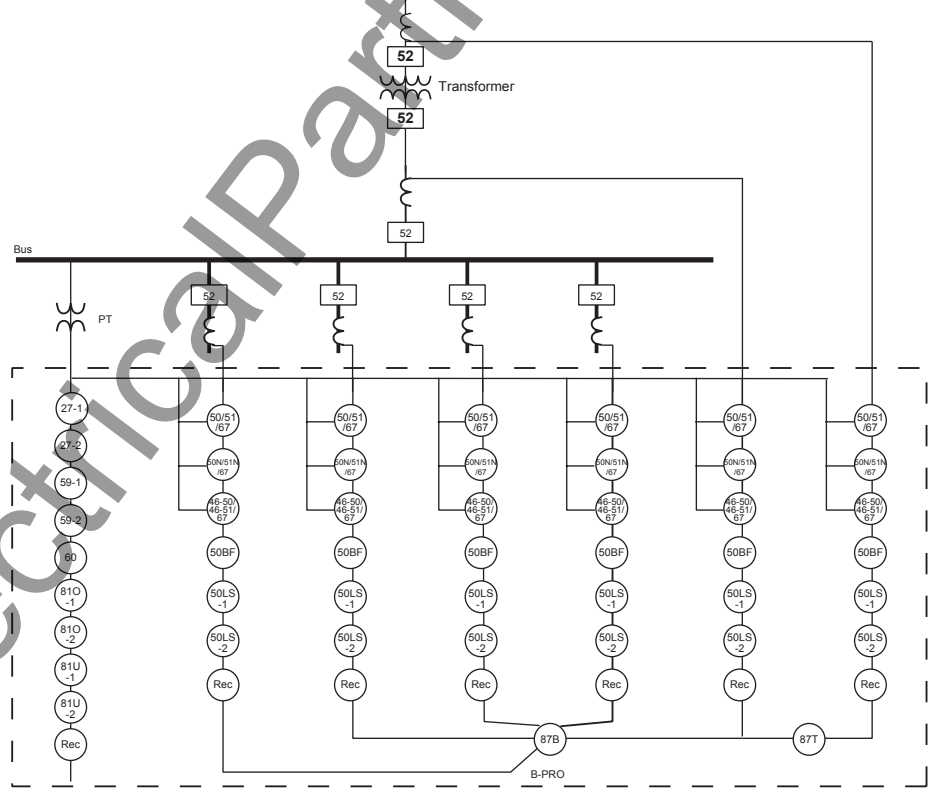

Figure 1.2: B-PRO Function Diagram (2 differential zones, 1 Bus & 1 Transformer)

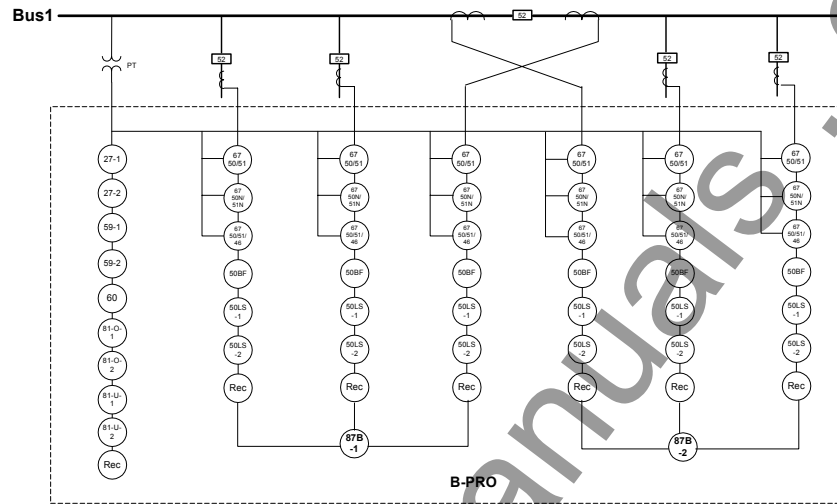
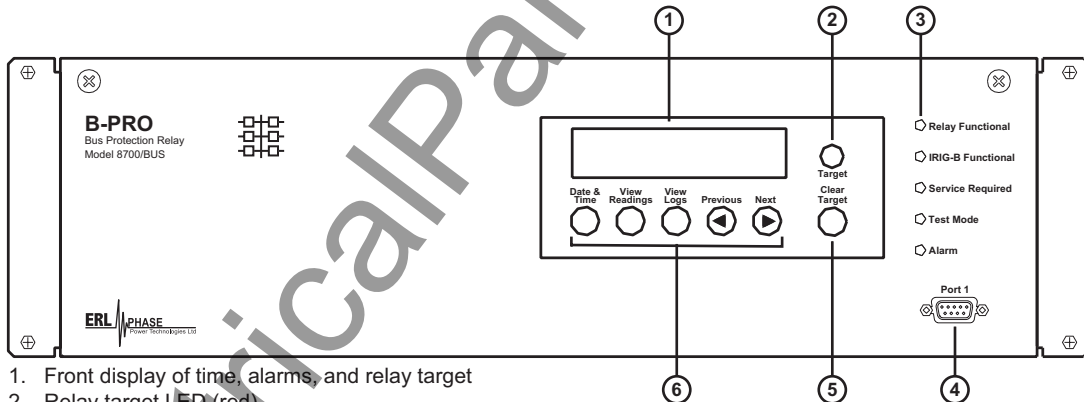

Figure 1.3: B-PRO Function Diagram (2 differential zones: Bus1 and Bus2)

Front View



1. Front display of time, alarms, and relay target
2. Relay target LED (red)
3. LEDs indicating status of relay
4. Communications serial port 1 for laptop computer
5. Clear target push button
6. Push buttons to manipulate information on LCD display

Figure 1.4: B-PRO Front View

Back View

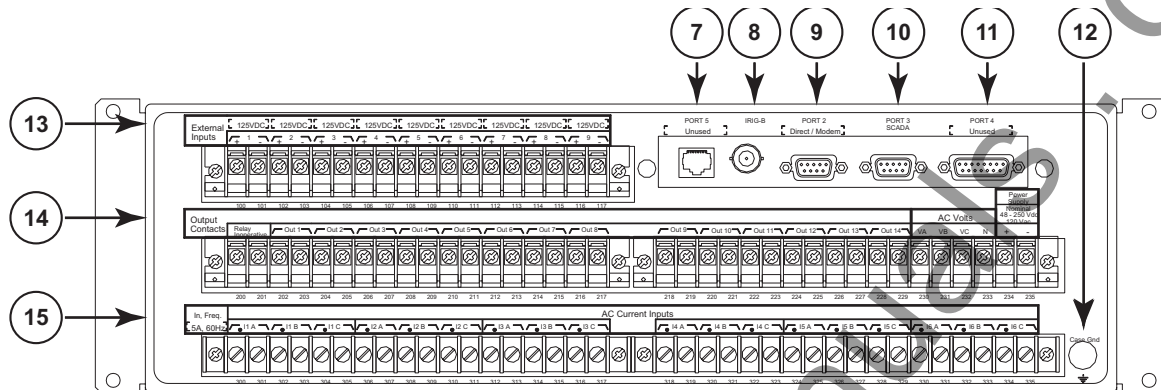

7. Port 5 - 10BaseT Ethernet Port/Internal Modem (optional)
8. External clock, IRIG-B modulated or unmodulated
9. Port 2 - Direct/Modem RS-232 Port
10. Port 3 - SCADA
11. Port 4 - unused
12. Case ground
13. 9 programmable inputs
14. This row contains 4 distinct areas from left to right:
 - Relay Inoperative contact
 - 14 programmable output contacts
 - 3 ac voltage inputs
 - power supply
15. 18 ac current inputs

Figure 1.5: B-PRO Back View

AC Current and Voltage Inputs

B-PRO is provided with terminal blocks for up to 18 ac currents and 3 phase to neutral voltages.

Each of the current input circuits has polarity (•) marks.

A complete schematic of current and voltage circuits is shown, for details see “AC Schematic Drawing” in Appendix I and “DC Schematic Drawing” in Appendix J.

External Inputs

The B-PRO relay contains 9 programmable external inputs. External dc voltage of either 48/125 volts or 125/250 volts nominal are possible depending on the range provided.

To prevent an external input from picking up on spurious voltage pulses, a software filter is applied to the input signals. The filter ignores logic high voltage levels that occur for less than 2 milliseconds. This was increased from 700 microseconds in firmware version 2.1.

Output Relay Contacts

The B-PRO relay has 14 output relay contacts. Each contact is programmable and has breaker tripping capability. All output contacts are isolated from each other. The output contacts are closed for a minimum of 100 ms after operation.

Relay Inoperative Alarm Output

If the relay is in self check program or becomes inoperative, then the Relay Inoperative Alarm output contact closes and all tripping functions are blocked.

Model Options/Ordering

B-PRO is available as a horizontal mount, for details see “Mechanical Drawings” in Appendix G.

B-PRO is available with an internal modem card or internal network card.

The CT inputs are 1 A nominal or 5 A nominal. The external inputs are 48/125 Vdc or 125/250 Vdc. The system base frequency is either 50 Hz or 60 Hz.

All of the above options must be specified at the time of ordering.

www.ElectricalPartManuals.com

2 Setup and Communications

Power Supply

A wide range power supply is standard. The nominal operating range is 48 to 250 Vdc, 120 Vac, 50/60 Hz. To protect against a possible short circuit in the supply use an inline fuse or circuit breaker with a 5 A rating. Make the chassis ground connection to ensure proper operation and safety.

There are no power switches on the relay. When the power supply is connected, the relay starts its initialization process and takes about 40 seconds to complete showing the green Relay Functional LED.

Case Grounding

You must ground the relay to the station ground using the case-grounding terminal at the back of the relay, for details see for details see Figure 1.4: B-PRO Front View on page 1-3.

WARNING!

To ensure safety and proper operation you must connect the relay to the station ground using the rear grounding terminal on the relay.

Ground the relay even when testing.

Do not rely on the rack mounting screws to provide case grounding.



IRIG-B Time Input

The relay is equipped to handle modulated or unmodulated GPS satellite time IRIG-B signals. The IRIG-B time signal is connected to the BNC connection on the back of the relay. When the IRIG-B signal is provided to the relay and is enabled in the settings through the user interface, the IRIG-B functional LED comes on and the relay clock is referenced to this signal. No settings are required to differentiate between modulated or unmodulated signals; this is automatically detected by the relay.

You can enable or disable the IEEE 1344 extension in the terminal mode settings *Utilities>Setup>Time*. The enabled mode receives the year from the IRIG-B signal. Disable this setting, if the available IRIG-B signal has no year extension.

Communicating with the Relay (IED)

You can connect to the relay to access its user interface and SCADA services by:

- direct serial link (user interface and SCADA)
- external or internal modem link (user interface only)
- ethernet network link (user interface and SCADA)

Direct Serial Link

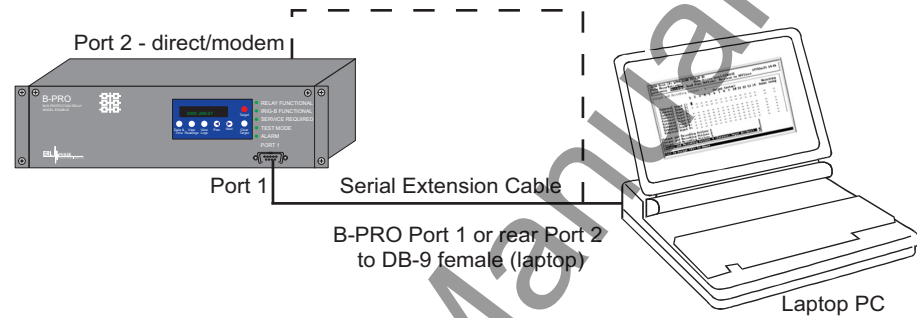

Figure 2.1: Direct Serial Link

The relay has three serial ports that provide direct access to its user interface and SCADA services.

All of the relay's serial ports (Ports 1, 2 and 3) are configured as EIA RS-232 Data Communications Equipment (DCE) devices with female DB9 connectors. This allows them to be connected directly to a PC serial port with a standard straight-through male-to-female serial cable, for pin-out, for details see "Communication Port Details" on page 2-8.

The relay's user interface is accessed through a standard VT-100 terminal emulation program running on a PC. To create a direct serial link between the relay and your computer, connect the serial cable (provided) between your computer's serial port and Port 1 on the relay's front panel. Port 2 on the relay's back panel can also be used for direct serial access, provided the port is not configured for modem use. When connected, run the terminal emulation software on your computer to establish the communication link, for details see "Using HyperTerminal to Access the Relay's User Interface" on page 2-5.

The relay's Modbus and DNP3 SCADA services can be accessed via a direct serial link to Port 3 on the relay's back panel, for details see "Accessing the SCADA Services" on page 2-7.

Modem Link - External

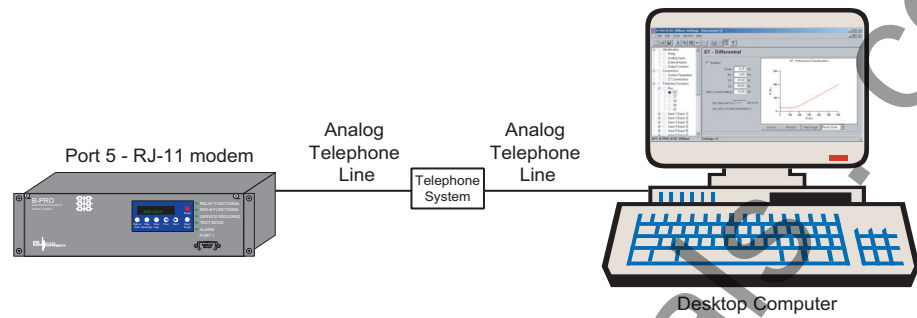

Figure 2.2: External Modem Link

Using an external modem, you can also access the relay's user interface through a telephone link between the relay and your computer.

Connect the serial port on the external modem to Port 2 on the relay's back panel. Both devices are configured as RS-232 DCE devices with female connectors, so the cable between the relay and the modem requires a crossover and a gender change. Alternatively, you can use the ERLPhase modem port adapter provided with the relay to make Port 2 appear the same as a PC's serial port. A standard modem-to-PC serial cable can then be used to connect the modem and the relay. For pin-out details see "Communication Port Details" on page 2-8. Connect the modem to an analog telephone line or switch using a standard RJ-11 connector.

You must appropriately configure the relay's Port 2 to work with a modem. Log into the relay through a direct serial link, go to the *Utilities>Setup>Ports* screen, and set *Port 2 Modem* option to *Yes*. Set the *Baud Rate* as high as possible — most modems handle 57,600 bps. The *Initialize* setting allows you to set the control codes sent to the modem at the start of each connection session. The factory defaults are: "M0S0=0&B1" for an external modem and "M0S0=0" for an internal modem.

Modem Link - Internal

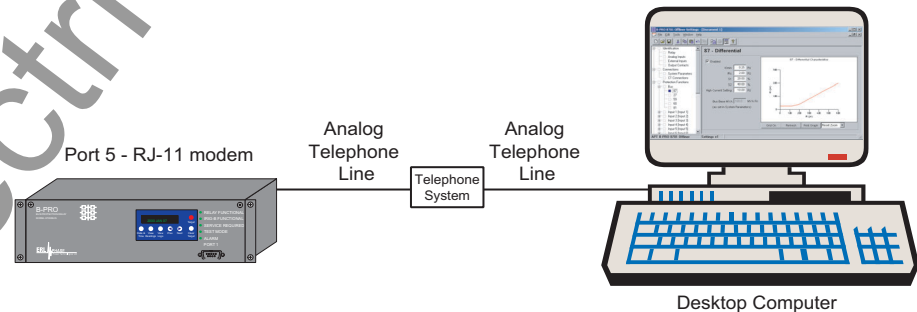

Figure 2.3: Internal Modem Link

You can access the relay's user interface through a telephone link between the relay and your computer using an optional internal modem. If the modem has been installed, Port 5 on the rear panel is labelled "INTERNAL MODEM."

Connect the relay's Port 5 to an analog telephone line or switch using a standard RJ-11 connector.

When an internal modem is installed, the relay's Port 2 is used to interface to the modem internally. Appropriate Port 2 settings are configured at the factory when the internal modem is installed. The factory defaults are: "M0S0=0&B1" for an external modem and "M0S0=0" for an internal modem.

Network Link

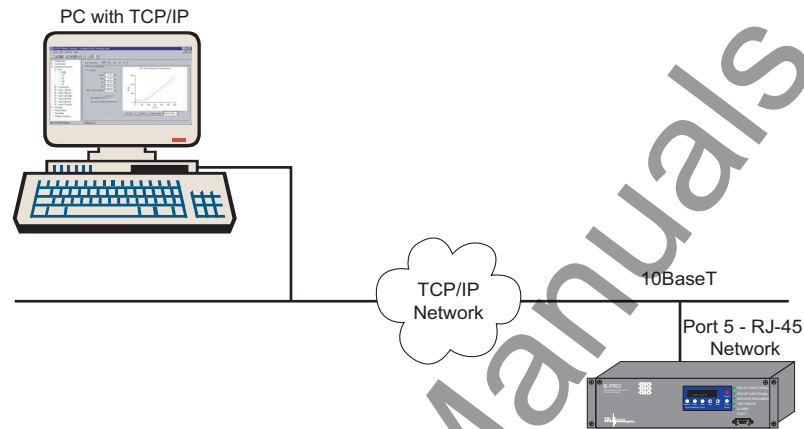

Figure 2.4: Network Link

You can access both the relay's user interface and DNP3 SCADA services simultaneously through the same network port with an optional Ethernet TCP/IP LAN link. If the Ethernet option has been installed, Port 5 on the rear panel will be labelled "NETWORK."

The user interface accessed through the LAN is the same as that available through a direct serial connection or a modem link, but requires the use of a Telnet client on your PC. The HyperTerminal program included with Microsoft Windows provides Telnet services. To select Telnet, go to HyperTerminal's Properties dialog box and set the *Connect Using* field to *TCP/IP (Winsock)*. If this option is not available in the pick list, you require a newer version of HyperTerminal (v1.2 or greater). Alternatively, you can use any Telnet program that fully supports VT-100 terminal emulation and z-modem file transfer.

DNP3 SCADA services can also be accessed over the LAN, for details see "Accessing the SCADA Services" on page 2-7.

Connect Port 5 to the Ethernet LAN using an appropriate 10BaseT cable with an RJ-45 connector. The relay supports 10 Mbit Ethernet, although a dual speed 10/100 Ethernet hub or switch can be used.

By default, the relay is assigned an IP address of 192.168.1.100. If this address is not suitable, it may be modified using the relay's Maintenance Menu. For details see "Using HyperTerminal to Access the Relay's User Interface" on page 2-5.

Using HyperTerminal to Access the Relay's User Interface

Change settings, view measured values and retrieve data from the relay using its user interface. This section describes how to configure a standard Windows VT-100 terminal program on your PC for use with the relay.

The computer must be connected to the relay by one of its serial, modem or Ethernet communication ports, for details see "Communicating with the Relay (IED)" on page 2-2.

The relay user interface is accessed using a standard VT-100 terminal style program on your computer eliminating the need for specialized user interface software. Any terminal program that fully supports VT-100 emulation and provides z-modem file transfer services can be used. The HyperTerminal program included with Microsoft Windows is used here as an example.

Configure your terminal program as described in the table below and link it to the appropriate serial port, modem or TCP/IP socket on your computer.

Terminal Program Setup	
Baud rate	For a direct serial link the baud rate must match that of the relay serial port. For a modem link the baud rate refers only to the link between your computer and its own modem. Refer to "Setting the Baud Rate" on page 2-6 for further information.
Data bits	8
Parity	None
Stop bits	1
Flow control	Hardware or Software. Hardware flow control is recommended. The relay automatically supports both on all its serial ports.
Function, arrow and control keys	Terminal keys
Emulation	VT100
Font	Use a font that supports line drawing (e.g. Terminal or MS Line Draw). If the menu appears outlined in odd characters, the font you have selected is not supporting line drawing characters.

To initiate a connection with the relay use HyperTerminal's *Call>Connect* function.

When the connection is established, press *Enter* in the terminal window to bring up the following login prompt.

```

----- NxtPhase B-PRO 8700 Terminal User Interface login -----
Log in using one of the following usernames:
'view' - read-only access to settings and readings
'change' - read/write access to settings and readings
'service' - full access to all functions (Port 1 access only)
'maintenance' - access to the maintenance menu
'update' - to load a firmware update

Notes:
- Serial and modem connections have a 60 minute inactivity timeout
- Usernames and passwords are case sensitive

login:

```

Instructions for logging in and running the user interface are given in “Terminal Mode” on page 3-4.

If you see incorrect characters on a direct serial connection, it may mean there is a mismatch between the relay’s baud rate and that of the PC.

Ending a User Interface Session

Use the *Quit* function in the relay’s user menu to end a session. This closes the interface and requires the next user to login to the relay.

The relay automatically ends a session when it detects the disconnecting of a direct serial cable or a modem hang-up. For other types of connections (e.g. serial switches or Ethernet) use the *Quit* function to ensure the interface is closed and login protection is activated.

Setting the Baud Rate

The baud rate of the relay’s serial ports can be shown on the relay’s front panel display. From the main *Date & Time* display, press the *Next* button.

Direct Serial Link

For a direct serial connection both the relay and your computer must be set to the same baud rate.

To change the baud rate of a relay serial port:

- 1 Access the relay’s user interface through any of the available ports.
- 2 Login to the user interface and go to the *Utilities>Setup>Ports* menu, for details see “Terminal Mode” on page 3-4.
- 3 Select the desired baud rate for the appropriate port by toggling through the options using the Space or Enter keys. Save the new setting with the F2 key. The message “New communications settings loaded” will appear.

The new baud rate will be used on that port the next time you login to it.

To change the baud rate on your computer’s serial port:

- 1 From HyperTerminal bring up the *Properties* dialog box, press the *Configure* button and set the baud rate field to the desired value.
- 2 Save the changes.

Modem Link

Unlike a direct serial link, the baud rates for a modem link do not have to be the same on your computer and on the relay. The modems automatically negotiate an optimal baud rate for their communication.

The baud rate set on the relay only affects the rate at which the relay communicates with the modem. Similarly, the baud rate set in HyperTerminal only affects the rate at which your computer communicates with its modem. Details on how to set these respective baud rates are described in “Modem Link - External” on page 2-3, except that you modify the Port 2 baud rate on the relay and the properties of the modem in HyperTerminal.

Accessing the SCADA Services

The relay supports DNP3 (Level 2) and Modbus SCADA protocols as a standard feature on all relays. DNP3 is available through a direct serial link or the Ethernet LAN on top of either TCP or UDP protocols. The Modbus implementation supports both RTU (binary) or ASCII modes and is available through a direct serial link.

The relay’s Port 3 is dedicated for use with Modbus or DNP3 serial protocols. Port 3 uses standard RS-232 signalling. An external RS-232<->RS-485 converter can also be used to connect to an RS-485 network.

For details on connecting to serial Port 3 see “Communicating with the Relay (IED)” on page 2-2 and “Communication Port Details” on page 2-8.

The DNP3 protocol can also be run across the optional Ethernet LAN. Both DNP over TCP and DNP over UDP are supported, for details on connecting to the Ethernet LAN see “Network Link” on page 2-4.

Complete details on the Modbus and DNP3 protocol services can be found in “Modbus RTU Communication Protocol” in Appendix E and “DNP3 Communication Protocol” in Appendix F.

Protocol Selection

To select the desired SCADA protocol, login to the relay’s user interface and access the *Utilities>Setup>SCADA* menu. Select the protocol and set the corresponding parameters.

The DNP3 LAN/WAN - TCP and UDP options are only available if the unit has an optional Ethernet LAN port installed.

Ensure the Master IP Address is different from the relay’s IP Address.

Communication Parameters

Port 3’s communication parameters are set using the *Utilities>Setup>Ports* menu in relay’s user interface. Both the baud rate and the parity bit can be configured. The number of data bits and stop bits are determined automatically by the selected SCADA protocol. Modbus ASCII uses 7 data bits. Modbus RTU and DNP Serial use 8 data bits. All protocols use 1 stop bit except in the case where either Modbus protocol is used with no parity; this uses 2 stop bits, as defined in the Modbus standard.

Diagnostics

Protocol monitor utilities are available to assist in resolving SCADA communication difficulties such as incompatible baud rate or addressing. The utilities

can be accessed through the Maintenance user interface, for details see “Maintenance Menu” on page 2-11.

Communication Port Details

Port	Location	Function
1	Front Panel	RS-232 Data Communication Equipment (DCE) female DB9. Used for user interface access through a direct serial connection. Default Setting: 38,400 baud, 8 data bits, no parity, 1 stop bit.
2	Rear Panel	RS-232 DCE female DB9. Used for: <ul style="list-style-type: none"> • User interface access through a direct serial connection. • User interface access through an external modem. The optional ERLPhase Modem Adapter converts this port to a Data Terminal Equipment (DTE) to simplify connection to an external modem. Default Setting: 9,600 baud, 8 data bits, no parity, 1 stop bit. Port 2 is disabled if the relay is equipped with an internal modem (see Port 5).
3	Rear Panel	RS-232 DCE female DB9. Used for SCADA communication. Default Setting: 9,600 baud, 8 data bits, no parity, 1 stop bit.
4	Rear Panel	Not used
5	Rear Panel	RJ-11/RJ-45 receptacle. When equipped with optional internal modem: <ul style="list-style-type: none"> • Used for user interface access through modem. When equipped with optional internal Ethernet card: <ul style="list-style-type: none"> • User interface access. • DNP SCADA access. Default Ethernet IP address: 192.168.1.100.

Signal Name	Direction PC<-> Relay	Pin # on the Relay Port
DCD	←	1
RxD	←	2
TxD	→	3
DTR	→	4
Common		5
DSR	←	6
RTS	→	7
CTS	←	8
No connection		9

Notes:

- Relay is DCE, PC is DTE
- Pins 1 and 6 are tied together internal to the relay

Male DB-9 Cable End for Relay Port	Female DB-9 Cable End for Computer Port
Pin # on Cable	Pin # on Cable
1	1
2	2
3	3
4	4
5	5
6	6
7	7
8	8
9	9

Signal Name	Direction Modem <-> Relay	Pin # on the Modem Adapter
DCD	→	1
RxD	→	2
TxD	←	3
DTR	←	4
Common		5
DSR	→	6
RTS	←	7
CTS	→	8
No connection		9

Notes:

- Relay (with modem adapter) is DTE, modem is DCE
- Pins 1 and 6 are tied together internal to the relay

Maintenance Menu

The relay has a Maintenance Menu that can be accessed by connection through a VT-100 terminal emulator (such as the HyperTerminal program that comes with MS Windows). Using either direct serial or modem connection:

- 1 Use the terminal program to connect to the serial port, either through direct serial link or modem.
- 2 Select *Enter*, the relay responds with a login prompt.
- 3 Login as “maintenance” in lower case.

A menu appears as below.

```
NxtPhase System Utility v1.3
NxtPhase
Customer support : (204) 477-0591, support@nxtphase.com

1 : Modify IP Address, subnet mask and default gateway (if applicable)
2 : View system diagnostics
3 : Retrieve system diagnostics
4 : Restore ALL default settings, including calibration
5 : Restore only default configuration settings (channel definitions, device se)
6 : Restore only default system setup (ports, time settings)
7 : Force hardware reset
8 : View network statistics (if applicable)
9 : Monitor SCADA
10 : Enable/Disable Internal Modem (if one exists)
11 : Exit

Please enter a command:
[1-11] # _
```

Commands 1, 4, 5, 6, 7 and 10 are Port 1 access only.

Modify IP address	Modifies the LAN IP address when equipped with an optional internal 10BaseT Ethernet card.
View system diagnostic	Displays the internal status log.
Retrieve system diagnostics	Automatically packages up the internal status log plus setting and setup information and downloads it in compressed form to your computer. This file can then be sent to our customer support to help diagnose a problem.
Restore settings	Use this menu to force the system back to default values, if you suspect a problem due to the unit's settings, calibration and/or setup parameters.
Force hardware reset	Manually initiates a hardware reset. Note that the communication link is immediately lost and cannot be re-established until the unit completes its start-up.
View network statistics	View IP, TCP and UDP statistics when equipped with internal 10BaseT Ethernet card.
Monitor SCADA	Shows real time display of SCADA data.
Enable/disable Modem	Enables or disables the internal modem.

Firmware Update

The relay has an update login that can be accessed by a connection through a VT100 terminal emulator (such as HyperTerminal). This login is available only from Port 1.

- 1 Use the terminal program to connect to Port 1.
- 2 Select *Enter*, the terminal responds with a login prompt.
- 3 Login as **update** in lower case.

The firmware update is used to update the relay's software with maintenance or enhancement releases. Please see the B-PRO Firmware Update Procedure documentation that comes with the firmware update for instructions on how to update the firmware on the relay.

3 Using the IED (Getting Started)

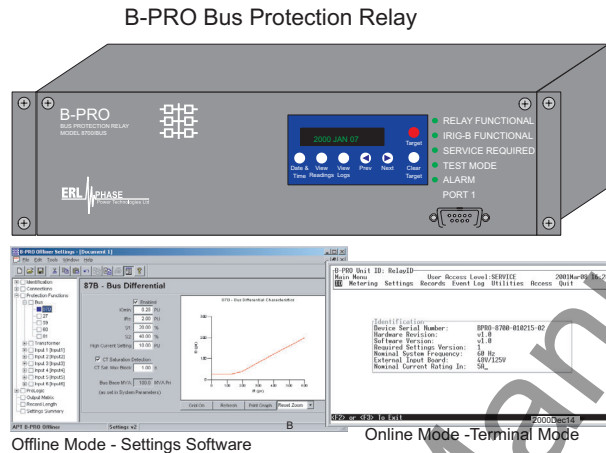

Start-up Sequence

The following initialization sequence takes place:

Test Mode—red LED on	2 seconds after power applied
Relay Functional—green LED on	5 seconds after power applied
Front Display—on	30 seconds after power applied
Test Mode—red LED off	40 seconds after power applied

When the relay is powered up, the normal sequence of LED operation is Test Mode followed by Relay Functional and IRIG-B Functional (if available), display on, then Test Mode off. The entire sequence takes about 40 seconds.

Ways to interface with B-PRO:

- Front panel display
- Terminal Mode
- *Offliner* Settings software (Details in Chapter 5-1)

Front Panel Display

The front panel display is the fastest and easiest way of getting information from the relay.

View or change settings using Terminal Mode or loading a setting file from *Offliner* Settings.

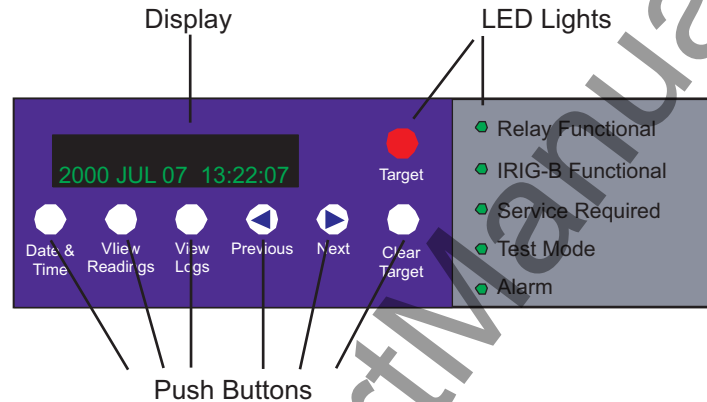

Figure 3.1: Front Panel Display

The front panel consists of a display, six LED lights and six push buttons.

LED Lights

Relay Functional	Indicates when the relay is functional. When the Relay Functional green LED goes on, the rear Relay Inoperative contact changes to an open and the protective functions become functional.
IRIG-B Functional	Indicates the presence of a valid IRIG-B time signal where the LED is on.
Service Required	Indicates the relay needs service. This LED can be the same state as the Relay Functional LED or can be of the opposite state depending on the nature of the problem. The following items bring up this LED: <ul style="list-style-type: none"> • DSP failure - protection difficulties within the relay. • Communication failure within the relay. • Internal relay problems.
Test Mode	Occurs when the relay output contacts are intentionally blocked. Possible reasons are: <ul style="list-style-type: none"> • Relay initialization on startup • User interface processor has reset and is being tested. <p>You cannot communicate with the relay through the ports until the front display becomes active and the TEST MODE LED goes out. Normally, the red Target LED remains off after this start-up unless the relay had unviewed target messages.</p>

Alarm	Occurs when an enabled relay function picks up. The red Alarm LED should be off if there are no inputs to the relay. If the Alarm LED is on, check the event log messages on the front display by pressing the <i>View Logs</i> button.
Target	Indicates that a fault has taken place. In the output matrix select which output contacts you want to activate when an alarm occurs.

Push Buttons

Date &Time	Pressing the Date &Time button displays the date and time stored on the relay. If the time is incorrect, connect to a PC in Terminal Mode and go to <i>Utilities>Setup>Time</i> to make the change or connect to the IRIG-B plug at the back of the relay. The front display time and date is automatically updated. The green IRIG-B Functional LED comes on. The relay accepts either modulated or unmodulated IRIG-B signals automatically. Options using IRIG-B such as time skew for different time zones are available when you establish communication with the PC.
View Readings	Pressing the View Readings button obtains metering information about the lines, for details see "Metering Data" on page 3-14.
View Logs	Pressing the View Logs button displays the target information, if a relay operation has occurred.
Previous/Next	Scroll through the menu by pressing Previous and Next. When the Date & Time is being displayed, pressing either of these buttons will display the Port 1 and Port 2 baud rates.
Clear Target	Use the Clear Target button to view all target information. When a fault takes place, the red target light appears. If many faults have been stored, you may need to push this button several times. Clearing the target light does not clear the target information from the relay log. The relay holds all target messages during a power supply shutdown and restart. Pressing the Clear Target push button displays any targets not previously viewed on the front display and clears the Target LED after the last target has been viewed.

Display

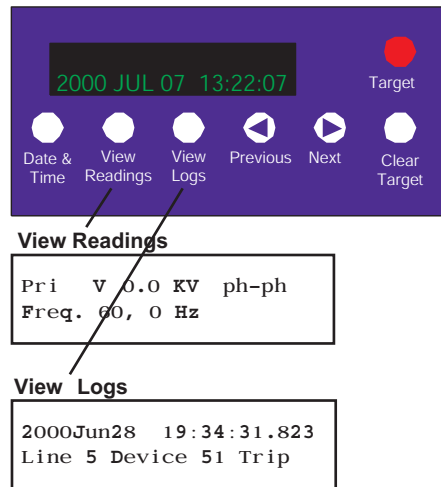

Figure 3.2: Display Examples

Front Panel Display Messages
PRI V, Frequency
Va, Vb, Vc magnitude and angle of bus PT
Ia, Ib, Ic magnitude and angle of each CT input
P and Q of each line
Tripping device targets, times and dates

For a detailed description of the metering data provided by the relay, see "Metering Data" on Page 3-14

Terminal Mode

The Terminal User Interface (TUI) is the main method of interaction between the relay and the user. From here the user can set the relay, load a setting file, view metering information, create and retrieve recordings, view logs, set-up system parameters and review system information. The following steps describe how to access the TUI.

Accessing TUI

- 1 Establish terminal mode connection, for details see "Using HyperTerminal to Access the Relay's User Interface" on page 2-5.

- 2 When the connection is established and the terminal mode program appears on your screen, the following prompt should appear. If it doesn't appear, press *ENTER*.

```

----- NxtPhase B-PRO 8700 Terminal User Interface login -----

Log in using one of the following usernames:
'view' - read-only access to settings and readings
'change' - read/write access to settings and readings
'service' - full access to all functions (Port 1 access only)
'maintenance' - access to the maintenance menu
'update' - to load a firmware update

Notes:
- Serial and modem connections have a 60 minute inactivity timeout
- Usernames and passwords are case sensitive

login:

```

- 3 Login as one of **view**, **change** or **service** (lower case). These three login names provide differing levels of permission, for details see “Access Levels” on page 3-5. Maintenance and Update are explained in “Maintenance Menu” on page 2-11 and “Firmware Update” on page 2-12.

The relay supports the optional use of passwords. A pop-up dialogue box appears after login has taken place.

If you have forgotten the password, go to *Access>Passwords* in Terminal Mode, for details see “Passwords” on page 3-6.

- 4 If login is successful, the Main Menu appears:

```

B-PRO Unit ID: UnitID
Main Menu      User Access Level: VIEW      2004 Jun28 11:49
ID Settings Metering Records Event Log Utilities Access Quit

```

view, change or service
(depends on how you log in)

If the box around the menu does not appear as above, change the font in your terminal program to one that supports line draw characters, e.g. terminal fonts. Also ensure that emulation is set to VT100 (not VT100J).

If there are incorrect characters in the display, improper line feeds or unerased portions, the baud rate is too high for the quality of the communication link. Use the *Utilities>Setup>Ports* menu to reduce the relay's baud rate. The new rate is in effect at the next connection.

Access Levels

The relay supports three user access levels that control what relay functions are available to you. The current access level is always shown in the centre of the Main Menu heading.

To change the Access Level either login again using the desired access level as your login name or use the *Main Menu*>*Access* menu.

Access	Level	Allowed actions
view	lowest	View settings, online readings and logs. List and retrieve records. At this level you cannot affect the operation of the controller.
change	middle	Do all of the above, plus change the settings and delete records.
service	highest	Do all of the above two categories, plus calibrate the analog inputs, manually control output auxiliary relays and modify passwords.

Service access is only available through a local, front port connection.

Passwords

Individual passwords for the view and change access levels are available to prevent or limit remote access to the relay. Passwords are not required for the service level. This level is only available at the front of the local relay through serial Port 1.

You can only change the passwords from the service level through the Access menu minimizing the chance that a password is changed casually and provides a means of resolving situations where a password has been forgotten.

Terminal Mode Menus

The menu tree consists of a series of sub-menus, which branch off from the Main Menu. For a map of the structure see "Terminal Mode Menus" on page 3-7. The features of the terminal mode screen are shown in Figure 3.3: "Terminal Mode Features", and explained below.

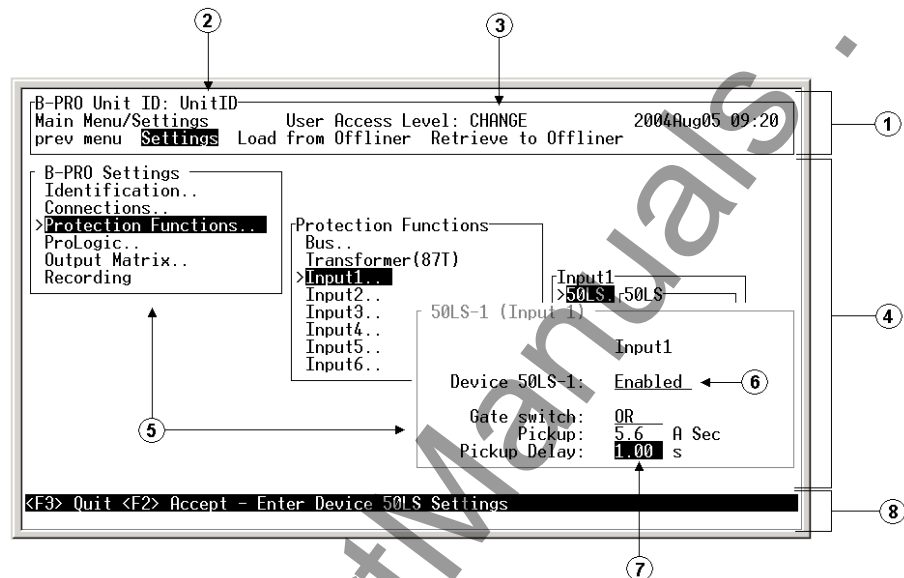

Figure 3.3: Terminal Mode Features

- 1 Main Menu Bar - This is where the menus are accessed. Use the right and left arrow keys to move the highlight. Items are selected using the <Enter> key. As a short-cut, use the first letter of the menu item to access it directly. The <Esc> key will take you back to the previous menu level.
- 2 Unit ID display - This is where the user-defined unit ID is displayed.
- 3 Access Level display - This is where the access level that you are logged in at is displayed.
- 4 Sub-Menu screen Area - This area is used when information is being displayed to or entered by the user.
- 5 Sub-Menu screens - There are two types, Intermediate and Data Entry/Display screens.
 - a. Intermediate screen - Used to navigate through menu system to the individual data entry/display screens. These screens are only used in the Settings>Settings menu. Use the arrow keys to move the highlight up, down, left or right through the screens. Items are selected using the <Enter> key. Using <F2> and <F3> will get you back to the Main Menu Bar. The difference is that <F2> will save settings and <F3> will not. The ".." after an item means that there are more sub-menus. If not then the data entry/display screen for that menu item will be displayed.
 - b. Data Entry/Display screen - Used to display and/or change data. These screens can include a variety of information including settings, record lists, event logs, utility settings, etc. This also includes screens where commands are made, such as calibration, controlling output contacts, etc. Use the arrow keys to move the highlight up, down, left or right through the screens. Using <F2> or <F3> at this point will take you back to the previous inter-

mediate screen. The difference is that <F2> will save the changes that were made and <F3> will leave the data intact.

In Figure 3.3, the screens with the heading "B-PRO Settings" and "Protection Functions" are examples of intermediate screens and "50LS-1 (Input 1)" is an example of a Data Entry/Display screen

- 6 List - Used in Data Entry/Display screens. Toggles through a list of entries. Ex. Enabled/Disabled. Pressing the <Enter> key toggles forward through the list and the <Space Bar> toggles backwards through the list. For long lists such as those found in the ProLogic screen, a drop-down box will appear that displays multiple selections. In this case you can also use the up and down arrow keys to scroll through the list. Pressing <u> or <d> will scroll through the list up or down one page at a time. In all cases, press <F2> to accept the setting or <F3> to close the box with no changes.
- 7 Entry Box - Used in Data Entry/Display screens. Enter text or numbers, where appropriate.
- 8 Status Bar - Provides clues and information about entering data.

Key	Function
<F2>	Accept or Freeze or Execute
<F3>	Quit or Exit
<Esc>	Back to previous menu level
<Enter>	Select or toggle forward
<Space Bar>	Toggle backward
<Up>, <Down>, <Left>, <Right>	Moves the highlight in the direction specified by the key pressed

Note: the mouse does not work in VT100 terminal mode.

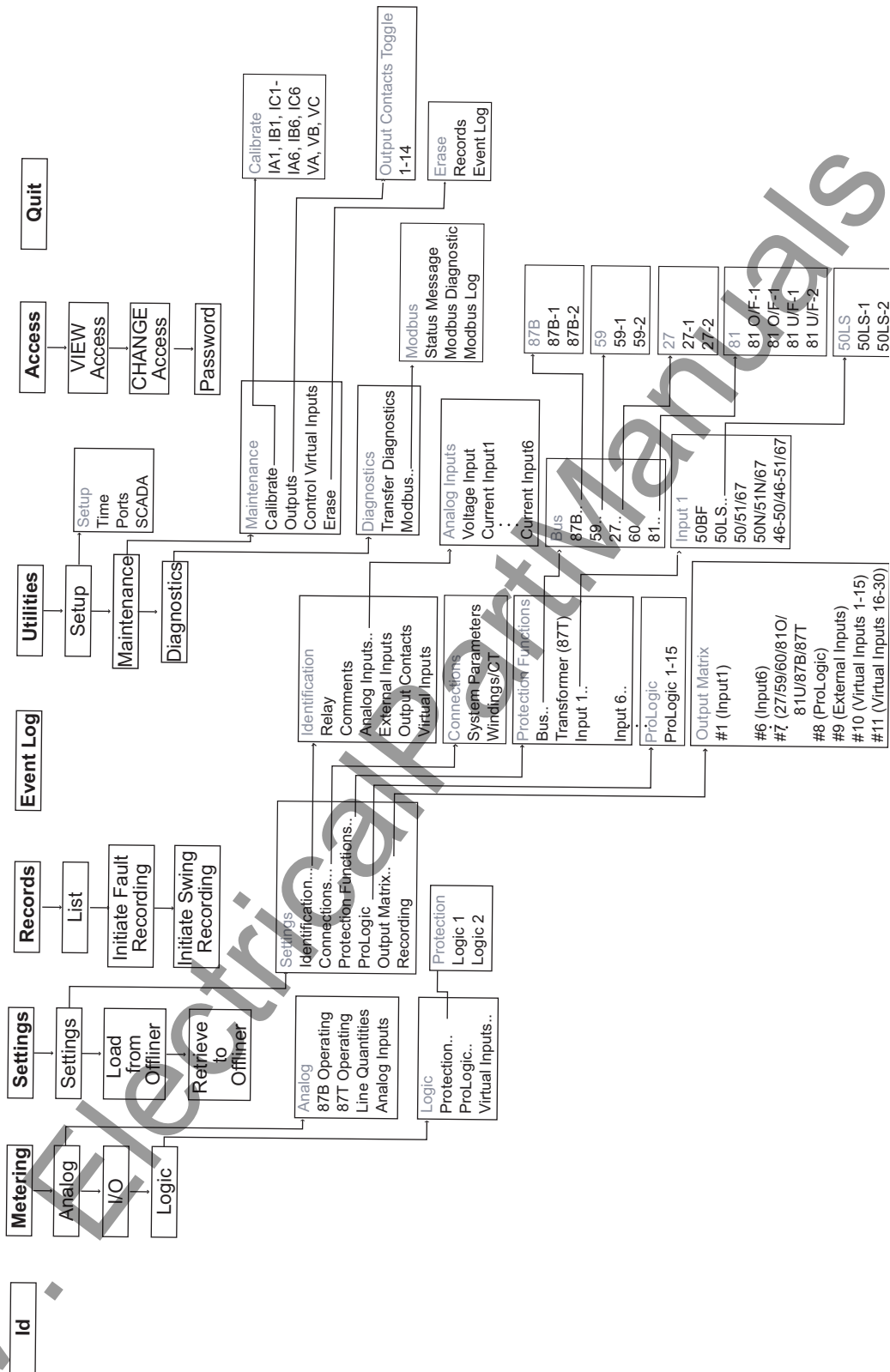

Figure 3.4: Terminal Mode Menus

ID

Provides the device serial number, software version, required settings version, nominal system values and external input board rating. There are no user settings here.

Metering

Submenus: Analog, I/O, Logic

Analog	
87B Operating	Provides information about operating and restraint current for 87B-1 and 87B-2.
87T Operating	Provides information about operating and restraint current for 87T.
Line Quantities	Provides primary MW and MVAR of each CT input.
Analog Inputs	Provides secondary values of the ac analog voltages and currents.

I/O	
I/O	Displays the state of the external inputs and the output contacts.

Logic	
Protection/Logic1	Provides the present status of the internal logic states.
Protection/Logic2	Provides the present status of the internal logic states.
ProLogic	Provides the present status of the ProLogic states. When a logic level becomes active, its state changes from low to high.
Virtual Inputs	Displays the state of the virtual inputs.

Settings

Submenus: Settings, Load from *Offliner*, Retrieve to *Offliner*

Settings

Settings includes all the submenus pertaining to protection functions used to create a relay setting. When these settings are made or changed, you can load them into the relay allowing input of all settings information for the relay.

Setting Submenus (Refer to Figure 3.4: "Terminal Mode Menu")	
Identification	These screens are where relay/station information can be entered, as well as names for the relay I/O.
Connections	These menus contain the settings that are used to define the primary system that is connected to the relay. Settings such as Bus Base MVA, Nominal Voltage Level are made in the System Parameters screen. The Windings/CT screen contains settings such as differential zone, CT ratio settings, transformer settings and digital control.
Protection Functions	These menus are used to make the individual settings for the various protection devices provided by the relay. Each of the sub menus above can be broken further into sub menus for the different protective zones available.
ProLogic	This is where each ProLogic statement that is provided by the relay can be defined. There are 15 ProLogic statements available in the relay, so there are 15 screens.

Output Matrix	This is where the relay's protection devices, external inputs, virtual inputs, and ProLogics can be configured to close output contact(s) or trigger recordings.
Recording	This screen contains the settings for setting the length of fault and swing recording.

Load From Offliner

You can download the settings file into the relay using the terminal mode menu.

- 1 On the Window's desktop, double-click B-PRO *Offliner* Settings icon. The initial *Offliner* Settings screen appears.
- 2 Enter the required settings.
- 3 Save the settings to a file on your PC.
- 4 Start the Terminal Mode of B-PRO, login as **change** or **service**, then access the *Settings* menu and activate *Load from Offliner* function.
- 5 Reply *Yes* to the "Ready to load remote setting." prompt.
- 6 In your terminal program, initiate transfer of the setting file created in step 2 above. (For example, with Window's HyperTerminal, you would select *Transfer*, then *Send File*. Browse to find the file, then select *Open* and finally, *Send*.)
- 7 When the file has been transferred, verified and loaded, a message "New settings loaded and secure" is displayed.

A "serial number discrepancy" message may appear. This is to ensure that you are aware of the exact relay to which the settings are being loaded. If this happens, check the relay serial number using the terminal mode ID menu item. Type this serial number into the B-PRO Serial No. box in the Identification tab display area of *Offliner* Settings. Alternately you may check the Ignore Serial Number check box to bypass serial number supervision.

Retrieve To Offliner

To transfer the relay's current settings to the PC do the following:

- 1 Navigate to *Settings>Retrieve To Offliner*.
- 2 Select *Enter*.
- 3 The relay asks you if you wish to continue. Select *Y* for yes.
- 4 The file is sent to the directory defined by the HyperTerminal menu *Transfer>Receive File*.

When using HyperTerminal use Z-modem (no crash recovery), files are received and auto incremented.

Records

Submenus - List, Fault Recording, Swing Recording.

Contains the means for initiating and examining recordings.

List	Lists all fault records.
Fault Recording	Creates one fault record.
Swing Recording	Creates one swing record.

Retrieve Records from the Relay

To retrieve records from the relay do the following:

- 1 Navigate to *Records>List* and press *Enter*; a records list appears.
- 2 Select *Records* using the space bar and select *R*. (You can also press *Enter* to retrieve a record directly.) The record will be saved in the directory specified by the terminal emulation program.

When using HyperTerminal if “Use receiving protocol:” is set to “Z modem with Crash Recovery”, file transfers are skipped by HyperTerminal if the record already exists in the downloads folder.

When using HyperTerminal use Z-modem (no crash recovery), files are received and auto incremented.

Delete Records from the Relay

To delete records from the relay do the following:

- 1 Navigate to *Records>List* and press *Enter*.
- 2 Select the records for deletion with the space bar and select *D*. The selected records will be deleted.

Event Log

The event log lists events stored in the relay. While viewing the Event Log, the event list must be manually refreshed in order to display new events. A complete list of the types of events logged is available, for details see “Event Messages” in Appendix D.

If an event triggered a record, then an (R) is displayed by the event.

Utilities

Sub-menus: Setup, Maintenance, Diagnostics.

Setup	
Time	Set manual time, IRIG-B skew control. Requires change or service access level.
Ports	Change Baud rates on communication ports. Requires change or service access level.
SCADA	Select which SCADA protocol (Modbus or DNP3) to run on the SCADA port. Configure parameters for the selected protocol such as address or timeout. Requires change or service access level.

Maintenance	
Calibrate	Calibrate all 21 analog ac. Requires service access level.
Outputs	Close and open output contacts independent of the associated relay functions. Requires service access level.
Control Virtual Inputs	Set, reset and pulse virtual inputs. Pulse width is 1 second. Latched virtual inputs reset after pulse command has executed. Requires change or service access level.
Erase	Use submenus Records and Event Logs to erase these records from the relay memory. Requires change or service access level.

Diagnostics	
Transfer Diagnostics	Transfers relay diagnostic file to the PC. The diagnostic file can be sent to ERLPhase for analysis.
Modbus	Allows Modbus Communications to enter its Diagnostic Mode. Follow directions on the screen. Programming done using the Modicon Modbus Protocol Reference Guide PI-MBUS-300 Rev. G published by Modicon, Inc., dated November 1994, for details see "Modbus RTU Communication Protocol" in Appendix E.

Access

Submenus: VIEW Access, CHANGE Access, Password.

View	Changes the access level to view. Allows you read-only access to relay information.
Change	Changes the access level to change. Allows you to modify settings and delete records.
Password	Allows you to read and change passwords. Requires service access level.

Quit

Selecting this option ends communication with the relay.

Metering Data

Front Panel Metering

The quantities provided on the front panel display include:

- Positive (primary) sequence L-L voltage
- Positive sequence frequency
- Phase to neutral bus voltage
- Inputs 1 to 6 A, B and C phase currents
- P and Q for each input

All quantities are in primary unless otherwise noted.

TUI Metering

The TUI provides the following metering quantities.

Analog/87B Operating

Provides the values of IO and IR for both the 87B-1 and 87B-2. It also displays the enabled/disabled status of the 87B-1 and 87B-2 protection functions. This screen is useful when testing.

Analog/87T Operating

Provides the values of IO and IR for both the 87T. It also displays the enabled/disabled status of the 87T protection function. This screen is useful when testing.

Analog/Line Quantities

Displays the P/Q information for each feeder, as well as the positive sequence L-L voltage and positive sequence frequency. All quantities are in primary values unless otherwise stated.

Analog/Analog Inputs

Displays all secondary values of the voltage and current inputs.

I/O

Displays the status of all external inputs and output contacts.

Logic/ProLogic

Displays the status of all ProLogic.

Logic/Protection/Logic 1

Displays the High/Low status of the 50LS, 50BF, 50/51/67, 50N/51N/67 and 46-50/46-51/67 for each input.

Logic/Protection/Logic 2

Displays the High/Low status of the 87B and 87T tripping/blocking/restraining functions, also including the 59, 27, 60 alarm, 81 High/Low status.

Logic/Protection/Virtual Inputs

Displays the status of all Virtual Inputs.

4 Protection Functions

Differential Zone Selection and CT Input Assignment

The B-PRO can be configured for a number of different differential zones. These zones are defined as:

- Bus1
- Bus1 and Transformer
- Transformer Only
- Bus1 and Bus2

Bus1 zone allows up to 6 current inputs to be used in the bus differential zone (87B-1). All CT's used for Bus Protection must be wired in wye.

Bus1 and Transformer zone allows up to 5 current inputs to be used for the bus zone and 2 inputs for the transformer zone. In this configuration, Input 5 is used for both the bus zone and the transformer zone. Inputs 1-4 are used for the bus zone. Input 6 is used for the transformer zone only. Inputs 1-5 must be wired in wye, but input 6 can be wired in wye or delta.

Transformer Only zone uses inputs 5 and 6 in the transformer differential zone (87T). Input 5 must be wired in wye, but input 6 can be wired in wye or delta.

Bus1 and Bus2 are used where 2 zones of bus differential protection are desired. In this case the maximum number of inputs that can be assigned to one zone is 4, with the minimum being 2. 87B-1 settings define the first differential zone and 87B-2 settings define the second.

In all cases, if a CT input will not be used, it should be set to "NC" or "not connected". This will remove this current input from any differential calculations. The CT input overcurrent functions and recording are still available.

Digital Control

Each CT input can be automatically excluded from all relaying, metering and recording functions based on the status of an associated external input. To set this feature, the Digital Control of the CT input must be enabled, the associated external input selected, and the state of "Exclude When" set. The CT input will be automatically excluded from all relaying, metering and recording functions when the status of the associated external input agrees with the "Exclude When" setting. This feature can be used to automatically adjust the CT inputs of a differential zone based on the changes in the bus configuration. The connections of "Exclude When" setting accommodates the use of "a" or "b" auxiliary contact as the digital control input.

Protection Function Descriptions

Bus Protection

87B-1 Bus Differential (Bus1 differential zone only)

Device 87B-1 is the main protection of the bus. It will operate for the internal faults and restraint for the external faults. Up to 6 CT inputs can be configured as the inputs of 87B-1 and controlled by external inputs. If external control is

enabled, and the corresponding external input is turned on, the ac analog current will be excluded from all relay metering and recording functions. There is no harmonic restraint provided for this function. Restraint quantities are summed; the magnitude sum is then divided by two. Operating quantities are summed vectors.

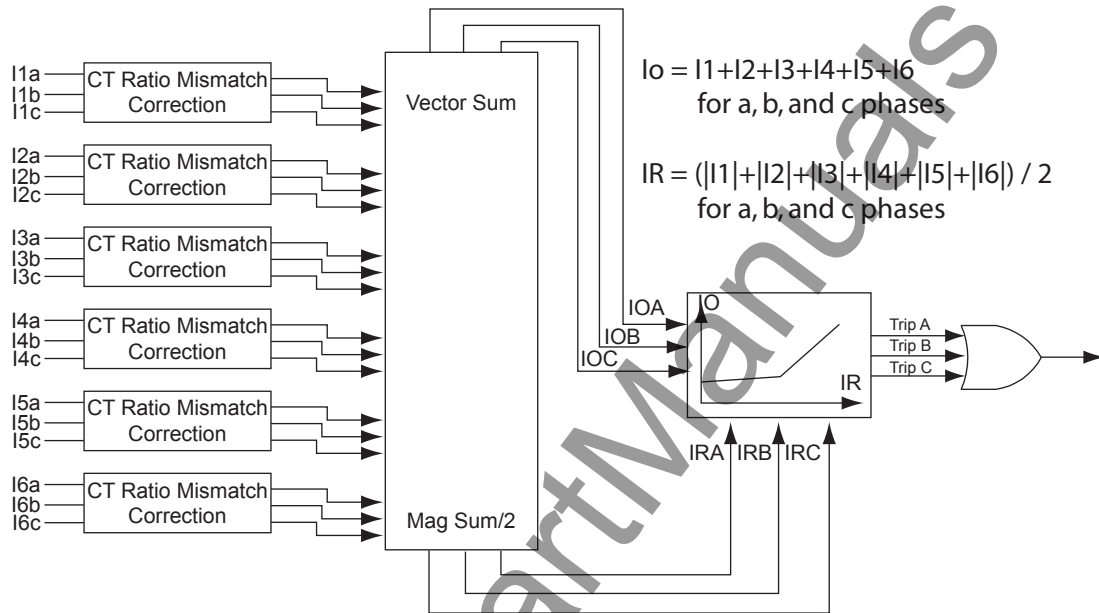

Figure 4.1: 87B-1 Bus Differential

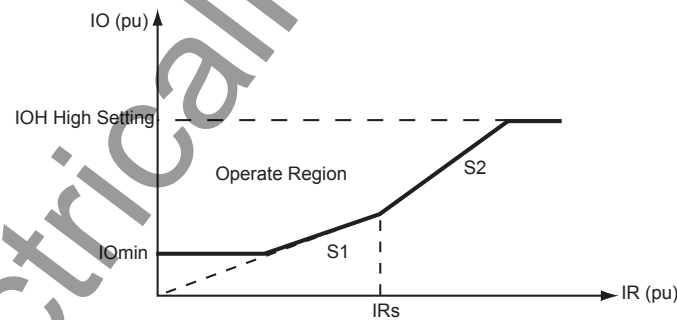

Figure 4.2: Bus Differential Characteristic

CT Saturation Detector

The B-PRO bus protection includes a significant improvement to the traditional two slope differential characteristic that provides immunity to CT mismatch and minimal CT saturation sensitivity for external faults. The CT saturation detector detects all CT saturation conditions for external faults and blocks the differential protection from operating.

The CT saturation detection and Trip-Blocking scheme are composed of two parts: the first part is to deal with the fast CT saturation, i.e. CT saturates in the first cycle after the fault occurs; the second part is to deal with the slow CT saturation, i.e. CT saturates after the first cycle.

Detection of Fast CT Saturation

Rather than examination of individual line fault currents for the presence of saturation, the detection method uses only IO and IR for its block/no-block decision. A novel algorithm (patent pending) has been developed to detect the fast CT saturation quickly, sensitively and accurately. The core of this algorithm is to check the phase relationship of dIO/dt and dIR/dt . For an internal fault, both IO and IR start to increase simultaneously and they are always kind of in phase. For an external fault, the phase dIO/dt is always lagging dIR/dt .

Detection of Slow CT Saturation

Sometimes CT does not saturate in the first cycle after the fault occurs due to the DC offset and the CT core remnant. Under these conditions, the algorithm described in above "Detection of Fast CT Saturation" could miss the detection of the changes of IR and IO, because of the limit of the sample window size in the DFT calculation. A "block zone" under the differential characteristic curve as shown in Figure 4.3 is defined to solve this.

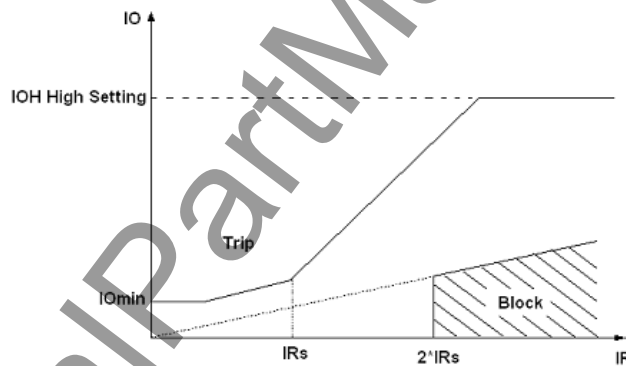

Figure 4.3: Detection of Slow CT Saturation

IR_s is the setting parameter, which is normally set to be greater than the maximum bus transfer load. The block level is preset to 2 times of IR_s for safety margin. The slope in the block zone is preset to 20% for safety margin to cover the maximum CT mismatch. Whenever the IO, IR trajectory is entered into the block zone, this algorithm for Slow CT Saturation Detection will set the block flag to block the differential element from tripping.

The CT saturation detector is simple to use and can be enabled or disabled. When enabled, you set a timer to control how long you want an external CT saturation condition to block the differential protection. Normally you would set this timer to be slightly longer than your maximum clearing time for an external fault.

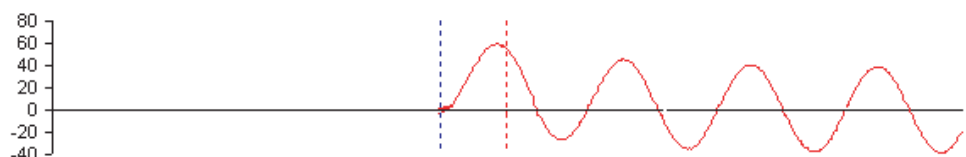

Figure 4.4: External Fault – Fully Offset Source Current

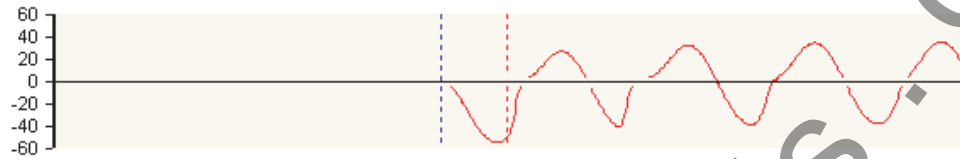

Figure 4.5: External Fault – CT Saturation

Additional Security

For additional security, some pickup delays are also applied to the differential protection function as described below.

IOmin and Slope1 (S1)

As shown in Figure 4.6, when the IO, IR trajectory enters into the trip zone from IOmin or slope1 region, a 6 ms (8 ms for 50Hz system) pickup delay is applied so as to be certain that the IO, IR trajectory has reliably come into the trip zone. To ensure the fast operating speed of 87B function for internal faults, IRs should be set to be greater than the maximum bus transfer load plus safety margin. The safety margin should be greater than S1/100 per unit. In this way, the IO, IR trajectories for internal faults are always entered into the trip zone from the IOmin and slope1 region rather than from the slope2 region under any pre-fault conditions.

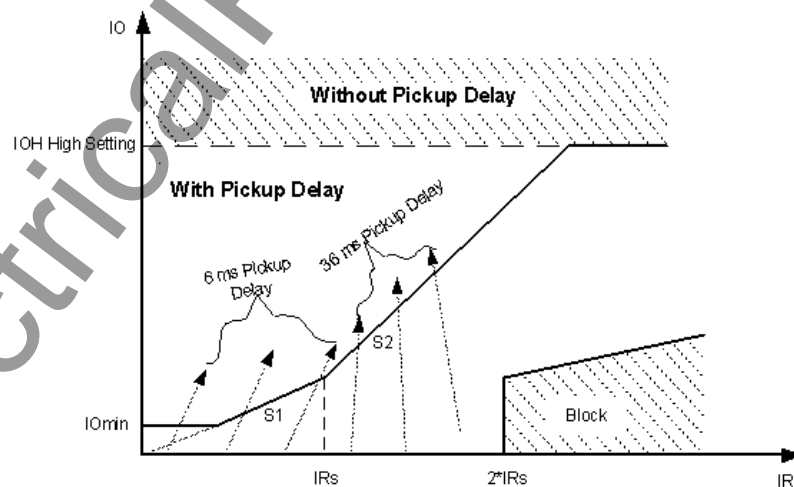

Figure 4.6: Pickup Delay for Additional Security

Slope2 (S2)

When a slow CT saturation occurs during an external fault as described in page 4-3, the IO, IR trajectory may enter the trip zone, but always from the slope2 region. In most cases when the slow CT saturation occurs, the IO, IR trajectory

will enter into the saturation block zone first so that the block flag will be set and 87B trip will be blocked accordingly. However, in some special situations when the fault current contains low AC current combined with high magnitude slow decaying DC current, the external fault current level may not be high enough to bring the IO, IR trajectory into the saturation block zone, but it might still bring the IO, IR trajectory into the trip zone from slope2 region for a short period of time (the CT recovers to normal quickly). In order to make the relay secure under these special situations, a 36 ms (45ms for 50Hz system) pickup delay is applied. As described before, this delay does not affect the operating speed for internal faults.

IOH High Setting

There is no any intentional delay as long as the IO exceeds the IOH setting threshold no matter where the IO, IR trajectory comes from. The purpose of the IOH zone is to clear the extremely severe bus internal faults as soon as possible

IOmin	Minimum level that device 87 operates
IRs	Point of intersection between slope 1 and slope 2 of the characteristic
S1	Slope of first part of characteristic meeting Io IOmin and slope 2
S2	Slope of second part of characteristic meeting slope 1 and high current unrestrained setting
IOH High Set	Heavy fault trip irrespective of restraint current.

The differential relay setting parameters are defined in “Bus Differential Characteristic” on page 4-2, the restraint quantity for the bus differential is the sum of the restraint quantities divided by two.

87B Bus Differential	
IOmin (pu)	0.20 to $\text{Min} \left(\frac{IRs \times S1}{100}, 1.00 \right)$
IRs (pu)	$\left(IOmin \times \frac{100}{S1} \right)$ to 50.00
S1 (%)	$\left(IOmin \times \frac{100}{IRs} \right)$ to $\text{Min} (S2, 100)$
S2 (%)	Max (S1, 30) to 200.00
High Current Setting (pu)	$IOmin \times 3$ to 100.00
CT Saturation Detection	Enable/disable
CT Sat. Max Block (seconds)	0.10 to 99.99

Bus Base MVA	Set in System Parameters
--------------	--------------------------

87B-2 Bus Differential

The 87B-2 is used to define the second bus differential zone. The 87B-2 is only available when the Differential Zone is selected as Bus1 and Bus2. Up to 4 CT inputs can be assigned to the 87B-2. The 87B-2 settings are the same as the 87B-1.

59 Overvoltage

Two sets of overvoltage protection elements are provided to monitor the bus voltage. The 59-1 and 59-2 functions are identical in terms of operation. Use the gate switch to select between an "AND" or an "OR" gate. Use an "AND" gate to detect 3-phase overvoltage condition; use an "OR" gate to detect any phase overvoltage condition. The definite time delay can be set to 0.0 for a instantaneous output.

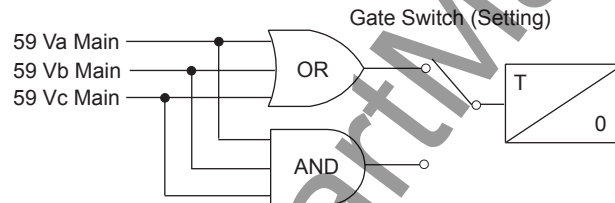

Figure 4.7: 59 Overvoltage

59 Overvoltage	
Gate Switch	AND or OR
Pickup (Volts Sec.)	60.0 to 138.0
Pickup Delay (seconds)	0.00 to 99.99

27 Undervoltage

Two sets of undervoltage protection elements are provided to monitor the bus voltage. The 27-1 and 27-2 functions are identical in terms of operation. Use the gate switch to select between an "AND" or an "OR" gate. Use an "AND" gate to detect 3-phase undervoltage condition; use an "OR" gate to detect any phase undervoltage condition. The definite time delay can be set to 0.0 for an instantaneous output.

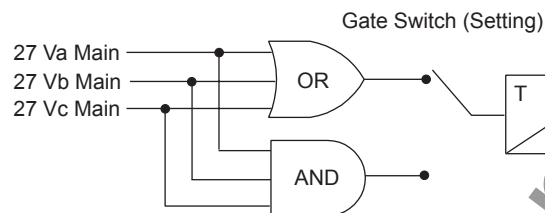

Figure 4.8: 27 Undervoltage

27 Undervoltage	
Gate Switch	AND or OR
Pickup (Volts Sec.)	1.0 to 120.0
Pickup Delay (seconds)	0.00 to 99.99

60 Loss of Potential

This protection is to detect the loss of potential from either one or two phases, and issue an alarm.

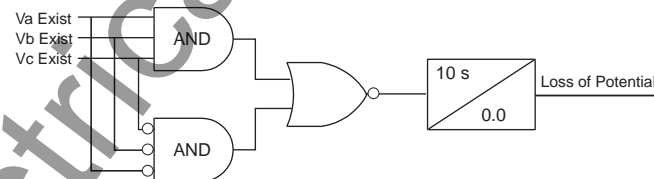

Figure 4.9: 60 Loss of Potential

Where $Va_Exist = 1$ if $Va > 0.5$ pu, similar for Vb_Exist and Vc_Exist . Pickup time (= 10.0 seconds) and drop-out time (= 0.0 seconds) are fixed parameters.

1.0 pu is calculated as:

$$V_{pusec} = \frac{\text{Bus Voltage (Pri)}}{\sqrt{3} \times (\text{PT Turns Ratio})}$$

60 Loss of Potential	
Pickup Delay	10 seconds (fixed)

81 Over/Under Frequency

The relay provides two sets of over frequency protection elements to monitor the bus frequency. The 81 O/F-1 and 81 O/F-2 functions are identical in terms of operation. Any positive sequence overfrequency condition produces an output. Undervoltage inhibit is provided and fixed at 0.25 pu of nominal system voltage.

The relay provides two sets of under frequency protection elements to monitor the bus frequency. The 81 U/F-1 and 81 U/F-2 functions are identical in terms of operation. Any positive sequence underfrequency condition produces an output. Undervoltage inhibit is provided and fixed at 0.25 pu of nominal system voltage.

The 81 frequency elements operate and produce an output using a definite time delay function. The overall time delay will be the user setting, an additional inherent delay from 1.25 cycles to 1.75 cycles, and an additional ± 3 ms operate time for the output contact. The element will have a total operate time of under 5 cycles when set to the minimum time delay setting of 0.05 seconds.

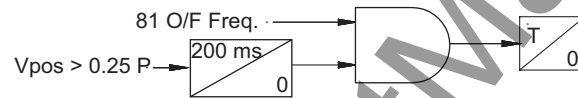

Figure 4.10: 81 O/F Over Frequency

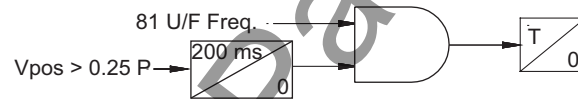

Figure 4.11: 81 U/F Under Frequency

81 Over/Under Frequency	
Pickup (Hz)	60.0 to 70.0 / 50.0 to 60.0 (60 Hz) 50.0 to 60.0 / 40.0 to 50.0 (50 Hz)
Pickup Delay (seconds)	0.05 to 99.99 (inherent delay of 1.25 to 1.75 cycles, depending on frequency step change)

Transformer Protection

87T Transformer Differential

Device 87T is the differential protection for the transformer zone. It can be used when the differential zone is selected as Bus1 & Transformer or Transformer Only. The device operates for internal faults and provides restraint for external faults, transformer energization or transformer over excitation conditions. CT input 5 and CT input 6 are dedicated for the differential device when 2 differential zones (bus and transformer) are selected, or if only 1 differential zone (transformer) is selected. If external control is enabled, and asserted, the ac analog current will be excluded from all relay, metering and recording functions.

Restraint quantities are summed; the magnitude sum is then divided by two. Operating quantities are summed vectors.

Device 87T has 2nd and 5th harmonic blocking, each element is set independent of each other. If an input phase current is less than 5% of I nominal, this current will not be used for the 2nd and 5th harmonic blocking calculation. For a 5A relay this equals 0.25A.

As shown below, the 2nd harmonics restraint signal is stretched for 5ms in the first cycle on transformer energization to prevent the 2nd harmonics restraint signal from any possible momentary reset due to the current signal transition in the first cycle. Note that this logic becomes active when the transformer has been de-energized or very lightly loaded (the restraint current is less than 30% of IOmin setting)

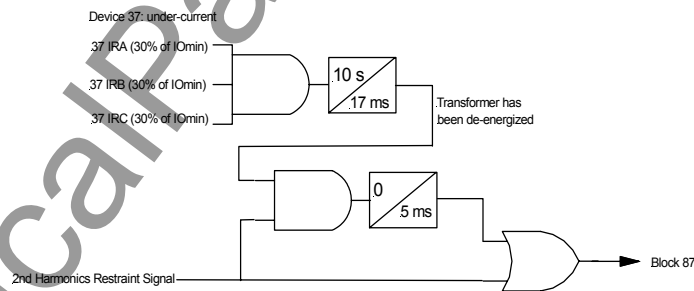

IOmin	Minimum level that device 87 operates
IRs	Point of intersection between slope 1 and slope 2 of the characteristic
S1	Slope of first part of characteristic meeting IO min and slope 2
S2	Slope of second part of characteristic meeting slope 1 and high current unrestrained setting
I2	Ratio of 2nd harmonic current to fundamental, used to provide energizing harmonic restraint
I5	Ratio of 5th harmonic current to fundamental, used to provide restraint on over excitation
IOH High Set	Unrestrained high set overcurrent, operates if a heavy fault occurs on the transformer irrespective of restraint

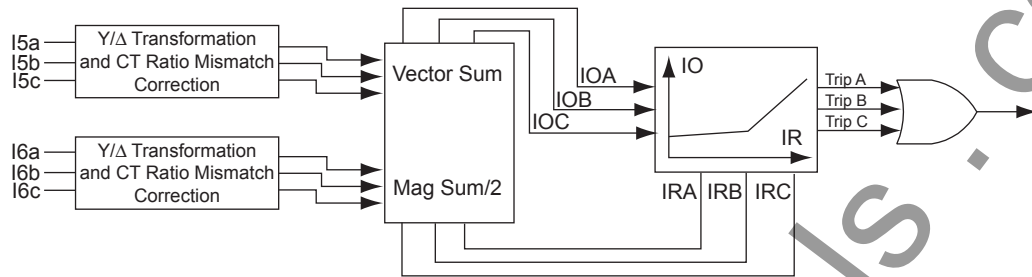

Figure 4.12: 87T Transformer Differential

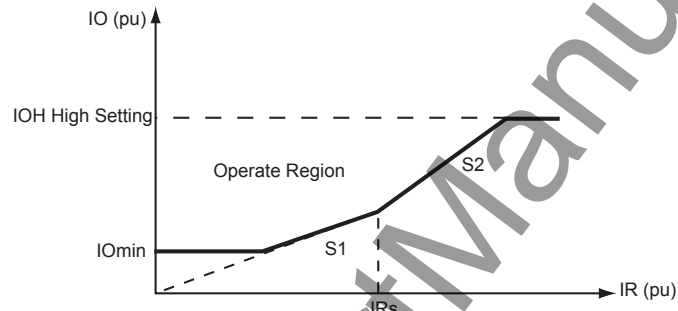

Figure 4.13: Transformer Differential Protection Characteristic

87T Transformer Differential	
IOmin (pu)	$0.2 \text{ to } \left(\frac{IRs \times S1}{100} \right)$
IRs (pu)	$\left(IOmin \times \frac{100}{S1} \right) \text{ to } 50.00$
S1 (%)	$\left(IOmin \times \frac{100}{IRs} \right) \text{ to } \text{Min}(S2, 100)$
S2 (%)	Max (S1, 30) to 200.00
High Current Setting (pu)	$IOmin \times 3 \text{ to } 100.00$
I _{2nd} /I _{fund} Ratio	0.05 to 1.00
I _{5th} Restraint Enabled	Enable/disable
I _{5th} /I _{fund} Ratio	0.05 to 1.00
Transformer Base MVA	Set in Winding/CT Connections

Inputs 1 to 6 Protection

50LS Low Set

Two sets of definite time delay overcurrent protection functions on each CT input provide non-directional current detection. The 50LS-1 and 50LS-2 functions are identical in terms of operation. Use the gate switch to select between an "AND" gate or an "OR" gate. Use an "AND" gate to detect 3-phase overcurrent condition; use an "OR" gate to detect any phase overcurrent condition. The definite time delay can be set to 0.0 for an instantaneous output.

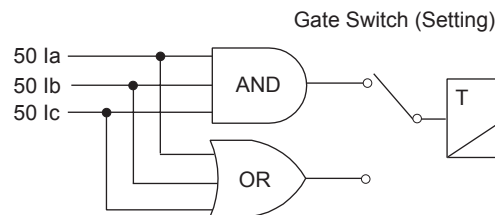

Figure 4.14: 50LS Low Set

50LS Low Set Overcurrent	
Gate Switch	AND or OR
Pickup (Amps Sec.)	0.1 to 50.0 (5A) 0.02 to 10.00 (1A)
Pickup Delay (seconds)	0.00 to 99.99

50BF Breaker Failure

Breaker failure protection function is used to detect breaker failures and react correspondingly. This function is provided on all the current inputs. When breaker failure is initiated by a trip (user-settable: include 87B-1, 87B-2, 87T, ProLogic, External Input or its own O/C functions) and the breaker current still exists, two timers (T1 and T2, user settable) will be started. After these timers are timed out, if the current still exists (which indicates breaker failure), the output of this function will be set high.

The two outputs of this function can be used to trip another trip coil or the next level of breakers, such as bus breakers. For example set T1 to 10 ms and T2 to 200 ms, and then use the output of T1 to send a trip to the associated circuit breaker before sending the output of T2 to the bus or transformer protection. If the output of T1 tripped the circuit breaker before T2 timed out the current input would dropout and you would not clear the whole transformer or bus zone.

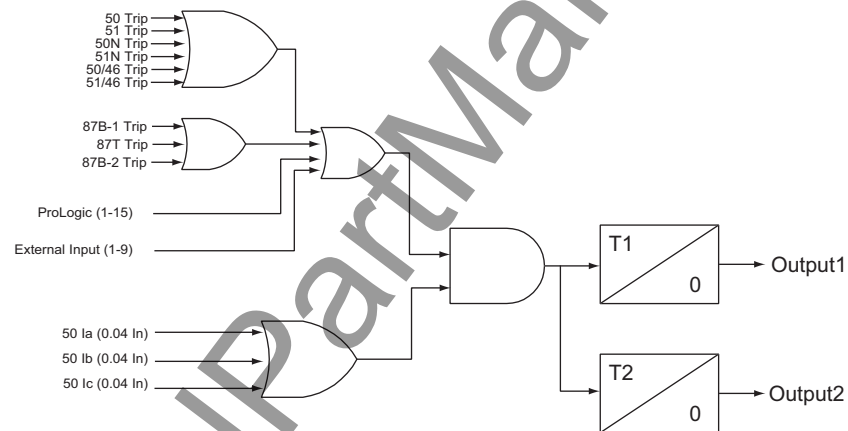

Figure 4.15: 50BF Breaker Failure

50BF Breaker Fail	
Breaker Failure Initiated by 87B-1	Enable/disable
Breaker Failure Initiated by 87B-2	Enable/disable
Breaker Failure Initiated by 87T	Enable/disable
Breaker Failure Initiated by ProLogic	ProLogic 1 to ProLogic 15
Breaker Failure Initiated by External Input	External Input 1 to External Input 9
Pickup Delay 1 (seconds)	0.01 to 99.99
Pickup Delay 2 (seconds)	0.01 to 99.99

67 Directional Element

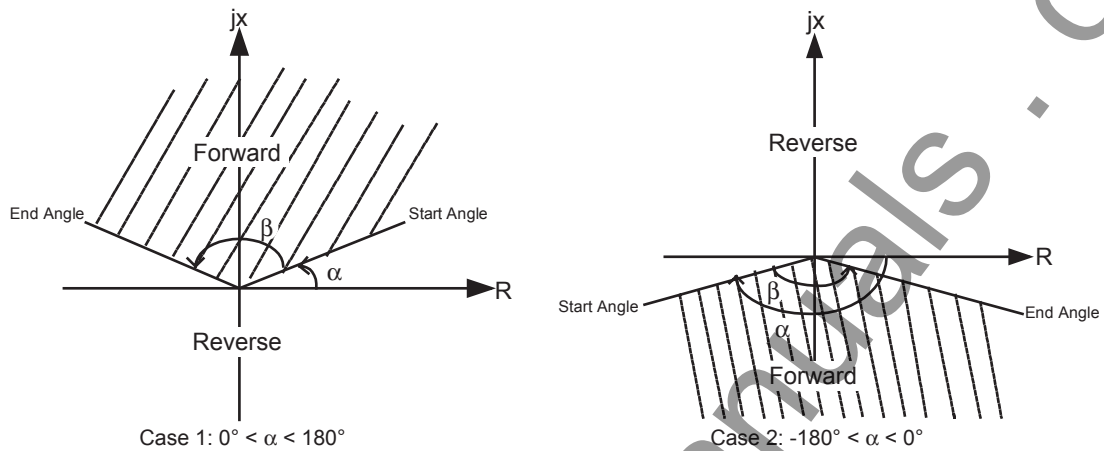

Figure 4.16: 67 Directional Element

Two user-defined parameters, Alpha (-179.9° to 180.0°) and Beta (0.1° to 360.0°), set in the system parameters setting area, define the directional element where Alpha is the start angle and Beta is the angle range (always positive), i.e. the end angle is Alpha + Beta. The forward direction is defined in the region where the line originates, the start angle, and rotates anti-clockwise completing at the end angle. for details see Figure 4.16: 67 Directional Element on page 4-13 illustrates the definition of the directional element. You can flexibly define the forward trip region by setting Alpha and Beta properly based on your needs.

When Beta is set to 360° the forward trip region becomes the whole complex range ($R + jX$), making the element fully non-directional, i.e. the fault is always declared as a forward fault even if the actual fault is not a forward fault.

Positive sequence memory voltage (V_{posMem}) and positive sequence current (I_{pos}) are used to decide the directionality of the fault, i.e. if the calculated positive sequence impedance through V_{posMem} and I_{pos} falls into the forward trip region as shown above, the fault is declared as a forward fault.

50/51/67 Phase Overcurrent

Phase overcurrent provides backup protection to the differential protection. This function operates on fundamental quantities of the highest phase current of the 3 phases. Two sets of phase time overcurrent protection functions on each CT input provide directional or non-directional current detection. There is a definite time overcurrent element (50) and an inverse time overcurrent element (51). You can configure both 50 and 51 to be non-directional, forward direction, or reverse direction sensitive. You can also configure both 50 and 51 outputs to initiate the 50BF protection element. Device 51 provides three predefined IEEE, three IEC inverse time curves, and one user-defined curve. The equation and the parameters of device 51 are listed below. You can select the user-defined curve type and the parameters in the equation are settable otherwise they are fixed and determined by the curve type.

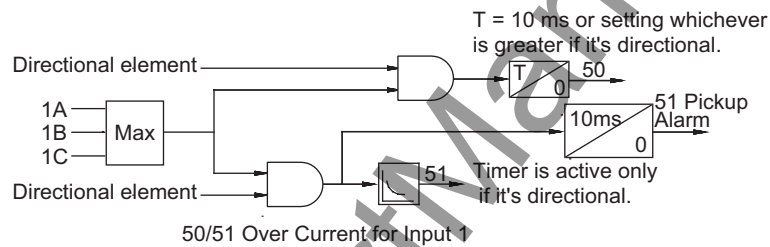

Figure 4.17: 50/51/67 Phase Overcurrent

When the threshold for pickup of the relay is exceeded, the function 51 alarm will pickup indicating the relay has commenced timing.

Table 4.1: IEC and IEEE Curves

#	Characteristic	A	B	p	tr
1	IEC Standard Inverse	0.14	0	0.02	13.5
2	IEC Very Inverse	13.5	0	1.0	47.3
3	IEC Extremely Inverse	80.0	0	2.0	80.0
4	IEEE Moderately Inverse	0.0103	0.0228	0.02	0.97
5	IEEE Very Inverse	3.922	0.0982	2.0	4.32
6	IEEE Extremely Inverse	5.64	0.0243	2.0	5.82
7	User-defined	0.0010 to 1000.0	0.0000 to 10.000	0.01 to 10.0	0.10 to 100.00

Pickup: For $I > \text{Pickup}$

$$T(I) = TMS \left(B + \frac{A}{\left(\frac{I}{\text{Pickup}} \right)^p - 1} \right)$$

Reset: For $I < \text{Pickup}$

$$T(I) = \left(\frac{TR}{\left(\frac{I}{\text{Pickup}} \right)^2 - 1} \right) TMS$$

50/51/67 Phase Overcurrent	
Directional	non-directional, forward, reverse
Pickup	0.5 to 50.0 (5A) 0.1 to 10.0 (1A)
Pickup Delay	0.00 to 99.99
50 Breaker Failure Initiated	enabled or disabled
51 Enabled	enabled or disabled
Directional	non-directional, forward, reverse
Pickup	0.5 to 50.0 (5A) 0.1 to 10.0 (1A)
Curve Type	For details see Table 4.1: IEC and IEEE Curves on page 4-14.
TMS	0.01 to 10.00
A	0.0010 to 1000.0000
B	0.0000 to 10.0000
p	0.01 to 10.00
TR	0.01 to 100.00
51 Breaker Failure Initiated	enabled or disabled

50N/51N/67 Neutral Overcurrent

Neutral Overcurrent provides protection for phase to ground faults. This function operates fundamental $3I_0$ quantities. Two sets of neutral time overcurrent protection functions on each CT input provide directional or non-directional current detection. There is a definite time overcurrent element (50N) and an inverse time overcurrent element (51N). You can configure both 50N and 51N to be non-directional, forward direction, or reverse direction sensitive. You can also configure both 50N and 51N outputs to initiate the 50BF protection element. Device 51N provides three predefined IEEE, three IEC inverse time curves, and one user-defined curve. The equation and the parameters of device 51N are listed below. You can select the user-defined curve type and the parameters in the equation are settable otherwise they are fixed and determined by the curve type.

50N/51N/67 Neutral Overcurrent	
Directional	non-directional, forward, reverse
Pickup	0.5 to 50.0 (5A) 0.1 to 10.0 (1A)
Pickup Delay	0.00 to 99.99
50N Breaker Failure Initiated	enabled or disabled
Directional	non-directional, forward, reverse
Pickup	0.5 to 50.0 (5A) 0.1 to 10.0 (1A)
Curve Type	For details see Table 4.1: IEC and IEEE Curves on page 4-14.
TMS	0.01 to 10.00
A	0.0010 to 1000.0000
B	0.0000 to 10.0000
ρ	0.01 to 10.00
TR	0.01 to 100.00
51N Breaker Failure Initiated	enabled or disabled

Pickup: For $I > \text{Pickup}$

$$T(I) = TMS \left(B + \frac{A}{\left(\frac{3I_0}{\text{Pickup}} \right)^{\rho} - 1} \right)$$

Reset: For $I < \text{Pickup}$

$$T(I) = \left(\frac{TR}{\left(\frac{3I_o}{\text{Pickup}} \right)^2 - 1} \right) TMS$$

46-50/46-51/67 Negative Sequence Overcurrent

Negative Sequence Overcurrent provides further protection for any unbalanced faults. This function operates fundamental I₂ quantities. Two sets of negative sequence time overcurrent protection functions on each CT input provide directional or non-directional current detection. There is a definite time overcurrent element (46-50) and an inverse time overcurrent element (46-51). You can configure both 46-50 and 46-51 to be non-directional, forward direction, or reverse direction sensitive. You can also configure both 46-50 and 46-51 outputs to initiate the 50BF protection element. Device 46-51 provides three predefined IEEE, three IEC inverse time curves, and one user-defined curve. The equation and the parameters of device 46-51 are listed below. You can select the user-defined curve type and the parameters in the equation are settable otherwise they are fixed and determined by the curve type.

46-50/46-51/67 Negative Sequence Overcurrent	
Directional	non-directional, forward, reverse
Pickup	0.5 to 50.0 (5A) 0.1 to 10.0 (1A)
Pickup Delay	0.00 to 99.99
46-50 Breaker Failure Initiated	enabled or disabled
Directional	non-directional, forward, reverse
Pickup	0.5 to 50.0 (5A) 0.1 to 10.0 (1A)
Curve Type	For details see Table 4.1: IEC and IEEE Curves on page 4-14.
TMS	0.01 to 10.00
A	0.0010 to 1000.0000
B	0.0000 to 10.0000
ρ	0.01 to 10.00
TR	0.01 to 100.00
46-51 Breaker Failure Initiated	enabled or disabled

Pickup: For $I > \text{Pickup}$

$$T(I) = TMS \left(B + \frac{A}{\left(\frac{I_2}{\text{Pickup}} \right)^P - 1} \right)$$

Reset: For $I < \text{Pickup}$

$$T(I) = \left(\frac{TR}{\left(\frac{I2}{\text{Pickup}} \right)^2 - 1} \right) TMS$$

ProLogic

The ProLogic control statements are used to create Boolean-like logic. The B-PRO can use any of the protection functions, external inputs or virtual inputs combined with logic gates to create a ProLogic control statement. The output of a ProLogic statement can be nested in another ProLogic statement, so long as the ProLogic output that is to be nested is of lower order than the one in which it is to be nested. For example, ProLogic 5 can be used in ProLogic 7 but not vice-versa.

The possible gates are AND, NAND, OR, NOR, XOR, XNOR, and LATCH. The control can be time delay pickup and or time delay dropout, and can drive the front panel target LED. 15 ProLogic control statements outputs are available and can be used in the output matrix to customize the relay to your specific needs. Inputs to ProLogic can be all the elements, previous ProLogic statements for logic nesting usage, as well as External and Virtual Inputs.

The example shows A to E inputs are status points of devices that are user-selectable. Each ProLogic output can be given a specific name, pickup and rest time delay.

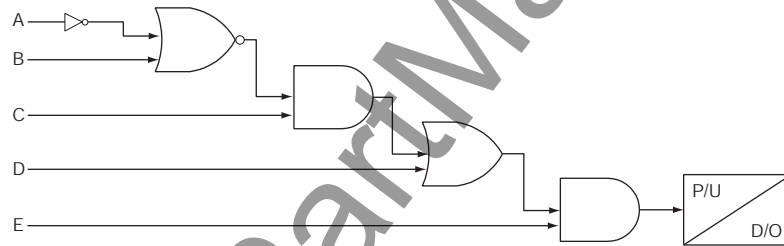

Figure 4.18: ProLogic

ProLogic Setting Functions	
Name	Give the ProLogic a meaningful name
Pickup Delay	Delay time from pickup to operate
Dropout Delay	Delay time from dropout to a ProLogic status of low
A, B, C, D, E	Relay elements as input statements
Operators	Boolean-type logic gates

Recording Functions

The relay has recording and logging functions to aid with the analysis of faults, and the overall performance of your protection scheme.

Fault Recording

The relay provides DFR-quality fault recording, capturing input signal waveforms and external input states at a rate of 96 samples per cycle. Each record also contains the timing of the internal logic produced by the relay (e.g. Device 87B-1 trip). Obtain this information by uploading the records from the relay via the terminal mode file transfer process and view them with RecordBase View software.

The quantities recorded are:

- 21 analog channels (3 voltages and 18 currents, in secondary volts and amperes respectively) @ 96 samples/cycle
- 9 operational currents and 9 restraint currents @ 8 samples/cycle (87B-1, 87B-2, 87T IO+IR)
- 9 external inputs @ 96 samples/cycle
- relay internal logic signals @ 8 samples/cycle, including virtual inputs
- 15 ProLogic signals @ 8 samples/cycle.

Parameters that are user-selectable with respect to recording faults:

- Record length (0.2–2.0 seconds => 12 – 120 cycles @ 60 Hz Base) with automatic extension to capture successive triggers
- Recorder triggering by any internal logic or external input signal

Swing Recording

The B-PRO records dynamic system responses allowing you to analyze system stability and to provide a larger context for fault analysis. Swing records contain positive sequence phasor measurements and system frequency calculated at a rate of 1 phasor per cycle. Swing records can extend to 3 minutes in duration.

The quantities recorded are:

- Positive sequence impedance (magnitude)
- Positive sequence voltage (magnitude)
- Positive sequence current (magnitude)
- 3-Phase Vars (reactive power)
- 3-Phase Watts (real power)
- Positive sequence frequency

Record Initiation

Recording can be initiated automatically by the relay when a fault or abnormal condition is detected. You can set the relay to initiate a fault record on activation of any of its trip or alarm functions or on assertion of any external inputs.

The assignment of fault record initiation to the various relay functions is done through the relay's Output Matrix settings.

A recording can also be initiated manually through the terminal user interface. The commands *Fault Recording* and *Swing Recording* are available under the *Records* menu.

A swing record can take a couple of minutes to produce due to the long post-trigger time.

Record Duration and Extension

The length of each record is determined by the Record Length setting. Fault record lengths can be set between 0.2 and 2.0 seconds; swing record lengths can be set between 30 and 120 seconds. Pre-trigger times are fixed at 10 cycles for fault records and 30 seconds for swing records and are included as part of the normal record length.

The B-PRO automatically extends a record as required to capture consecutive triggers that are close together. If a trigger occurs while a recording is in progress, the record is stretched to include the full post-trigger time of subsequent triggers, up to a maximum length—2.0 seconds for fault records; 180 seconds for swing records. If a trigger occurs before the end of a record caused by a previous trigger, but too late to allow sufficient post-trigger time in a maximum extended record, a new overlapping record is created.

The normal record lengths settings are accessible under the *Recording* heading of the relay settings, and can be set from either the terminal user interface or the *Offliner Settings* software.

Record Storage

The B-PRO compresses records on the fly, achieving a typical lossless compression rate of 4:1. As a result, the B-PRO can store up to 30 seconds of fault recordings and up to 24 minutes of swing recordings in non-volatile storage. If the storage is full, new records automatically overwrite the oldest, ensuring that the recording function is always available.

Record Retrieval and Deletion

A listing of stored records is available through the terminal user interface under the *Records>List* menu. The listing transfers records to a connected PC and deletes them from storage.

Example:

BPRO-8700-010306-04-2002-05-15 13.17.16.000(Fault)

Records are named by combining the Unit ID setting with the date and time of the initiating record trigger. The record list shows the record type (fault).

To delete a record from storage, use the up/down cursor keys to select the record, then select *<D>*. You can also do group deleting and group transferring.

To select multiple records:

- 1 Select a record.
- 2 Press the space bar, a asterisk appears to the left of the record to indicate it is selected.
- 3 Continue selecting and pressing the space bar until all desired records are selected.
- 4 Select *<D>*. A message asks “Delete all selected files?”. Select *Y* for Yes and the files are deleted.

To transfer a record to your PC, use the up/down cursor keys to select the record, then select *r*. The record is automatically transferred to your PC using

the PC terminal program's z-modem file transfer protocol. The record is placed in your terminal program's default to receive the directory which was set before transfer to. (e.g. Windows HyperTerminal's default receive directory is set through the its Transfer menu). When transferred, the record name remains unchanged and the file extension indicates the record type: ".bpr" for transient.

When the transfer has taken place, you can delete the record or leave a copy on the relay.

Event Log

The relay maintains a log of events in a 250 entry circular log. Each entry contains the time of the event plus an event description.

Logged events include trips, alarms, external input assertions plus internal events such as setting changes. Phase information is included in event messages where appropriate. For example, the event log entry for a device trip might be:

2000 Nov 21, 15:34:19.832: 51 on ABC Trip

The event log can be viewed in three ways:

Front Panel	The front panel display shows events in abbreviated form (Trip and Alarm events only).
Terminal User Interface	The full event log is available through the Event Log menu of the terminal user interface.
SCADA	The protocols included in the B-PRO allow all the SCADA master access to the event data from the relay (Trip and Alarm events only).

5 Offliner Settings Software

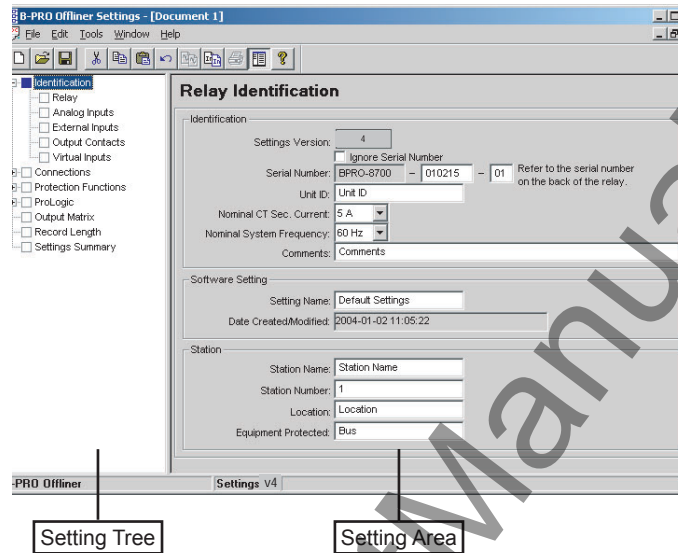

Figure 5.1: Opening Screen

Introduction

Use the *Offliner* Settings software to create relay settings on a PC. *Offliner* provides an easy way to view and manipulate settings. *Offliner* supports all firmware versions and has the capability to convert older setting versions into newer ones.

PC System Requirements

Hardware

The minimum hardware requirements are:

- Pentium processor
- 64 MB of available RAM
- 100 MB of available hard-disk space recommended
- VGA monitor
- CD-ROM drive
- Serial communication port

Operating System

The following software must be installed and functional prior to installing *Offliner* and RecordBase View software:

- Microsoft Windows 95, 98, ME, NT 4.0, 2000 or XP

Installing PC Software

Insert the CD-ROM in your drive. The CD-ROM should open automatically. If the CD-ROM does not open automatically, go to Windows Explorer and find the CD-ROM (usually on D drive). Open the B-PRO.exe file to launch the CD-ROM.

To install the software on your computer, click the desired item on the screen. The installation program launches automatically. Installation may take a few minutes to start.

To view the B-PRO User Manual you must have Adobe Acrobat on your computer. If you need a copy, download a copy by clicking on Download Adobe Acrobat.

Offliner Features

Menu and Toolbar

The *Offliner* software includes the following menu and system tool bar. Figure Figure 5.2: "Top Tool Bar" describes the details.

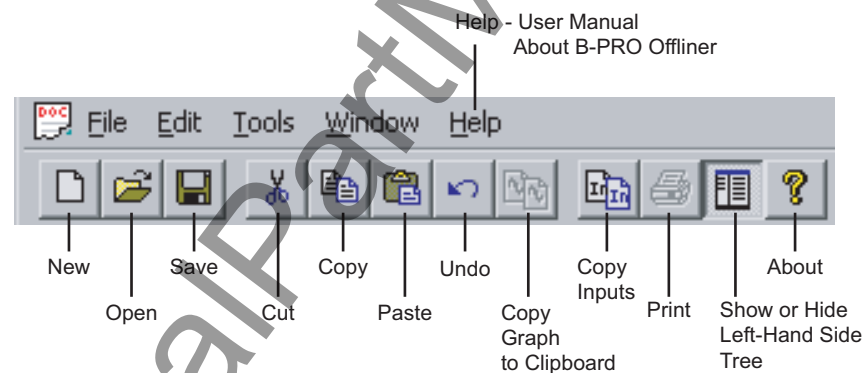

Figure 5.2: Top Tool Bar

Windows Menu		
Windows Menu	Sub Menu	Comment
Document Menu (Icon)	Restore	Restores active window to previous size
	Move	Allows user to move active window
	Size	Allows user to resize active window
	Minimize	Makes the active window as small as possible
	Maximize	Makes the active window as large as possible
	Close	Closes the active Offliner setting document
	Next	Switches to the next open Offliner setting file, if more than setting file is being edited

File Menu	New	Opens up a default setting file of the most recent setting version
	Open	Open an existing setting file
	Close	Closes the active Offliner setting document
	Save	Saves the active setting file
	Save As	Saves the active setting file with a new name or location
	Convert to Newer	Convert an older setting version to a newer version.
	Print	Prints graphs or setting summary depending on active screen
	Print Preview	Provides a print preview of the setting summary
	Print Setup	Changes printers or print options
	1-6	The six most recently accessed setting files
	Exit	Quits the program
Edit Menu	Undo	Undo last action
	Cut	Cut the selection
	Copy	Copy the selection
	Paste	Insert clipboard contents
	Copy Graph	Copy the graph for the active screen to the clipboard
	Copy Inputs	Brings up the Copy Inputs dialog box
Tools	Options	Displays the Options Dialog Box
Window	Cascade	Cascades all open windows
	Tile	Tiles all open windows
	Hide/Show Tree	If this option is checked then the LHS Tree view will be hidden
	1-9, More Windows	Allows access to all open Offliner setting files. The active document will have a check beside it
Help	User Manual	Displays the user manual
	About Offliner	Displays the Offliner version
Toolbar		
New	Create a new document.	Create a new document of the most recent setting version
Open	Open an existing document.	Open an existing document
Save	Save the active document.	Save the active document
Cut	Cut the selection.	Cut selection

Copy	Copy the selection.	Copy the selection
Paste	Insert clipboard contents.	Insert clipboard contents
Undo	Copy graph to clipboard.	Undo last action
Copy Graph		Copy the graph for the active scene to the clipboard
Copy Inputs	Copy inputs.	Brings up the Copy Inputs dialog box
Show/Hide LHS Tree		If this option is checked then the LHS Tree view will be hidden
Print	Print active document.	Prints Graphs or the setting summary, depending on which seen is selected
About	Display program information.	Displays the Offliner version

Graphing Protection Function Characteristics

For the devices that have characteristics such as the 51 and 87, graphs have been provided to aid in selecting settings. See Figure Figure 5.3: "87 Differential Slope Characteristic" and Figure Figure 5.4: "51 Inverse Time Overcurrent Characteristic" for examples of these graphs. The graph features are described below. Note that the protection function must be enabled in order to have it's characteristic displayed.

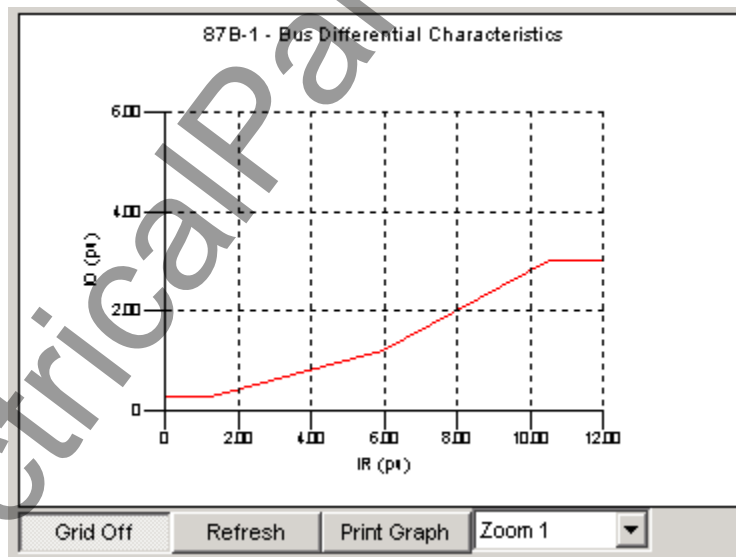

Figure 5.3: 87 Differential Slope Characteristic

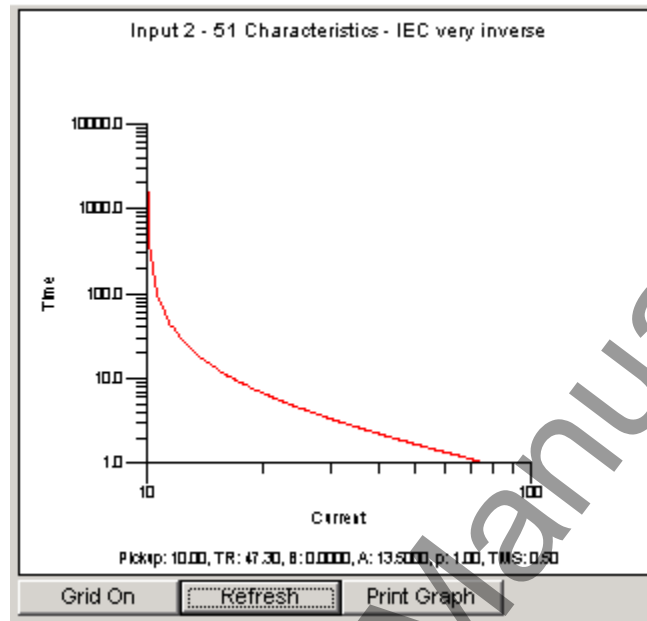

Figure 5.4: 51 Inverse Time Overcurrent Characteristic

Grid On/Grid Off

The graph can be viewed with the grid on or off by clicking the Grid On or Grid Off button. A right-click on the trace of the curve gives you the x and y coordinates.

Refresh

This button will manually refresh the graph if it has been zoomed.

Print Graph

To print a particular graph, click the *Print Graph* button.

Zoom on Graphs

Graphs can be zoomed to bring portions of the traces into clearer display. Left-click on any graph and drag to form a small box around the graph area. When you release the mouse, the trace assumes a new zoom position determined by the area of the zoom coordinates.

To undo the zoom on the graph, click the Refresh button.

Displaying Co-ordinates

At any time you may right-click on the graph to display the co-ordinates of the point you selected.

Copying Input Protection

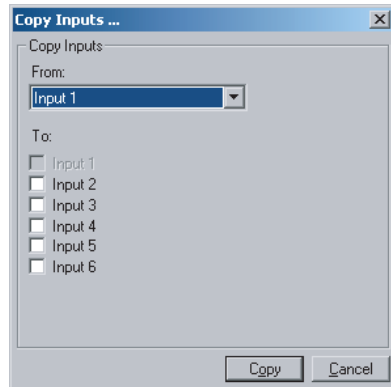

Figure 5.5: Copy Input Protection Functions

This feature allows the backup feeder protection that is provided for each input to be copied from one input to another. All the settings are duplicated exactly, including the output matrix. This is useful when you want to set each CT connection with the same protection characteristics.

This feature will copy all settings including the output matrix.

Main Branches from the Tree View

This section will describe the tree view, which provides access to the various setting screens. This section will not describe individual settings, but will provide a general description of where to find the individual settings. For a detailed description of the individual settings, see Chapter 4.

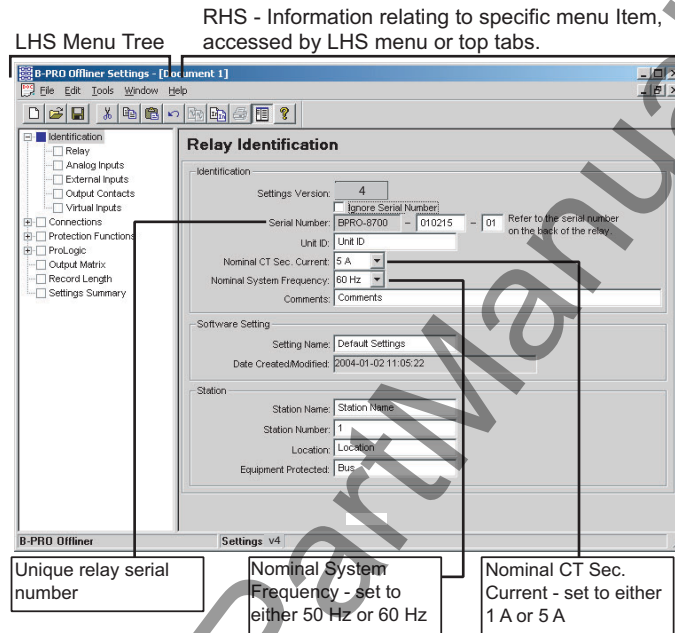

Figure 5.6: Relay Identification

In the LHS Menu Tree there are a series of menu headings that may have sub menus associated with them. Figure 5.6: "Relay Identification" shows the LHS tree view. Clicking on an item in the left hand side tree view will display its corresponding menu in the RHS view. Similarly, you can use the arrow keys to scroll through the menu tree.

The serial number of the relay must match the one in the setting file, or the setting will be rejected by the relay. This feature ensures that the correct setting file is applied to the right relay.

You can choose to ignore the serial number enforcement in the identification screen. The relay only checks for proper relay type and setting version if the ignore serial number has been chosen.

Identification

Sub Menus

Relay, Analog Inputs, External Inputs, Output Contacts, Virtual Inputs.

These screens are where relay/station information can be entered, names for the relay I/O and model specific options such as nominal CT current and system frequency can be entered.

Connections**Sub Menus**

System Parameters and Winding/CT

These menus contain the settings that are used to define the primary system that is connected to the relay. Settings such as Bus Base MVA, Nominal Voltage Level are made in the System Parameters screen. The Windings/CT screen contains settings such as differential zone, CT ratio settings, transformer settings and digital control.

Protection Functions**Sub Menus**

Bus, Transformer, Inputs 1-6

These menus are used to make the individual settings for the various protection devices provided by the relay. Each of the sub menus above can be broken further into sub menus for the different protective zones available. Note that selecting the Protection Functions item in the LHS tree view will display the Protection Summary screen in the RHS Tree view. This screen will display the enabled/disabled status of all devices in the relay, and will also allow these devices to be enabled/disabled.

Bus Sub Menu

This sub menu contains the settings for the devices that are in the Bus Zone. These functions are the 87B-1, 87B-2 and the voltage devices, 27, 59, 60, and 81.

Transformer Sub Menu

This sub menu contains only one item, the 87T settings. This is the only device that is provided for the transformer protection zone.

Inputs 1-6 Sub Menus

These menus are where the settings for the backup feeder protection are located. Inputs 1-6 are identical and include menus for 50LS, 50BF, 50/51/67, 50N/51N/67 and 46-50/46-51/67 settings.

ProLogic**Sub Menus**

ProLogic 1 - ProLogic 15

This where each ProLogic statement that is provided by the relay can be defined. There are 15 ProLogic statements available in the relay, so there are 15 screens. Similar to the Protection Functions menu, selecting ProLogic in the LHS tree view will bring up the ProLogic Summary screen, which displays the enabled/disabled status of all ProLogic. You can also enable or disable any ProLogic from this screen. This unique ProLogic name is also displayed on this screen, in brackets next to the generic ProLogic name.

Output Matrix

This is where the relay's protection devices, external inputs, virtual inputs, and ProLogics can be configured to close output contact(s) or trigger recordings.

Record Length

This screen contains the settings for setting the length of fault and swing recording.

Settings Summary

This menu provides a read-only list of all the relay's settings. The setting names, values, units and ranges are displayed. For the Protection devices, you can use the "display and print only enabled protection devices" option from the Tools menu to shorten the summary such that if a device is not enabled, its settings will be hidden, except that the enabled setting will be displayed. This is convenient if you are not using all of the available devices.

Offliner Keyboard Shortcuts

The following table lists the keyboard shortcuts that Offliner provides.

Ctrl+N	Opens up a default setting file of the most recent setting version
Ctrl+O	Open an existing setting file
Ctrl+S	Saves the active setting file
Ctrl+Z	Undo
Ctrl+X	Cut
Ctrl+C	Copy
Ctrl+V	Paste
Ctrl+F4	Closes the active Offliner setting document
Ctrl+F6	Switches to the next open Offliner setting file, if more than one setting file is being edited
F6	Toggles between the LHS Tree view and HRS screen
F10, Alt	Enables menu keyboard short-cuts
F1	Displays the user manual

Handling Backward Compatibility

Offliner Settings displays the version number in the second pane on the bottom status bar. The settings version is a whole number (v1, v2, v3, v4, etc.).

The *Offliner* Settings is backward compatible. Open and edit older settings files and convert older settings files to a newer version. *Offliner* Settings handles forward conversion only; it converts an older setting file to a newer setting file.

Converting a Settings File

- 1 Open the setting file you wish to convert.
- 2 In the *File* menu, select *Convert to Newer...* and then select the *version x* (where *x* is the newer version). A dialog box pops up prompting *Offliner* for a new file name. Use either the same file name or enter a new file name. The conversion process inserts default values for any newly added devices in the new setting file. When the conversion is complete, *Offliner* Settings displays the new file.

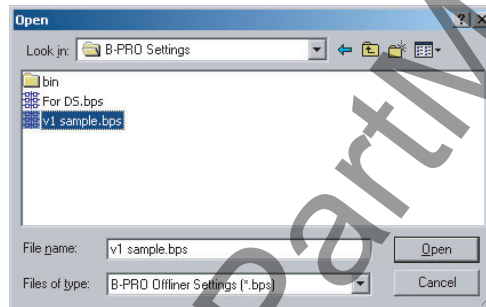

Figure 5.7: Converting Setting Files

Sending a New Setting File to the Relay

- 1 Make sure the settings version and the serial number of the relay in the setting file match. The relay will reject the setting file if either the serial number or the settings version do not match.

A “serial number discrepancy” message may appear. This is to ensure that you are aware of the exact relay in which settings are to be loaded. If this happens, check the relay serial number using the terminal mode ID menu item. Type this serial number into the B-PRO Serial No. box in the Identification tab display area of *Offliner* Settings. Alternately you may check the Ignore Serial Number check box to bypass serial number supervision.

- 2 Check the serial number and the settings version of the relay, for details see “ID” on page 3-10. The Device Serial Number and Required Settings Version on the Identification screen indicate the serial number and the settings version of the relay.

Creating a Setting File from an Older Version

- 1 *Offliner* Settings displays a default setting file on start up showing the settings version in the bottom status bar. As an example B-PRO *Offliner* is shipped with a set of default sample files of older settings versions. These sample files are “v1 sample.bps”, “v2 sample.bps”, “v3 sample.bps”, etc. Each sample file contains default values of an older settings version. For a new installation these sample files are placed in the default directory C:\Program Files\NxtPhase\B-PRO Offliner Settings, or you can choose the path during the *Offliner* software installation. If an older version of B-PRO *Offliner* was previously installed on your PC, then the default directory may be C:\Program Files\APT\B-PRO Offliner Settings.
- 2 Open a sample file of the desired version. Use *File/Save As* to save the sample file to a new file name. Then edit the setting file and the serial number, save it and load it into the relay.

RecordBase View Software

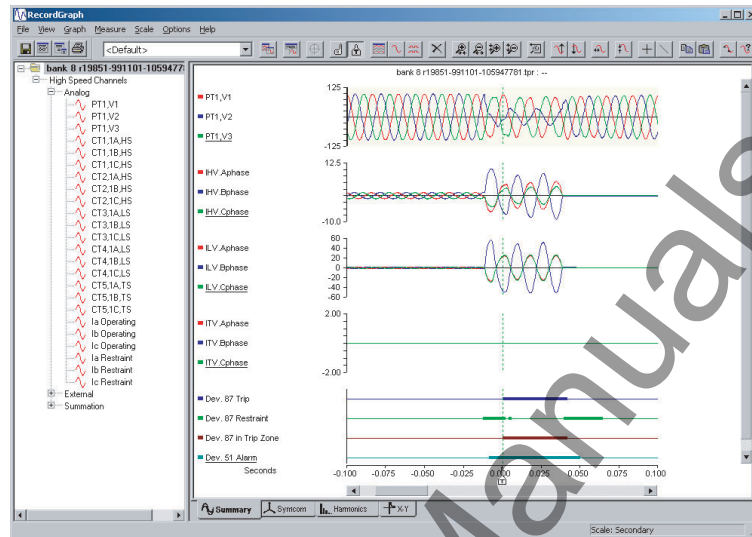

Figure 5.8: RecordBase View

Use RecordBase View to analyze the records from a relay.

- 1 Set the receive directory on your terminal program to point to a convenient directory on your PC's hard disk or network. For example with Windows HyperTerminal, select *Transfer>Receive File* to set the receive directory.
- 2 Select one or more records on the relay using the *List* function in the Terminal Mode's *Records* menu.
- 3 Initiate transfer of the selected records by selecting *R* on the keyboard.
- 4 Start the RecordBase View program and use the *File>Open* menu command to open the downloaded record files located in the receive directory specified in step 1.

For further instructions refer to the RecordBase View Manual at the back of the printed version of this manual.

6 Testing the B-PRO Functions

You can set Nominal CT Secondary Current to either 5 A or 1 A and Nominal System Frequency to either 60 Hz or 50 Hz. This example is set to 5 A/60 Hz.

Relay testing is required to determine if B-PRO performs correctly after the settings are complete or to determine verification of relay settings needed. In most cases a simple test using three voltage sources and three current sources is adequate. Testing the bus differential element requires up to six sets of three phase current sources when used in full capability. Use all the available metering functions during testing to verify issues such as polarities of voltage and current signals.

Calibration

The relay is calibrated when it leaves the factory; but if component changes are made within the relay, you may need to do a re-calibration.

Before you begin a new calibration, establish the accuracy of the equipment being used.

To perform a calibration, you must be logged into the relay in Terminal Mode at the Service access level. Proceed to the *Utilities>Maintenance>Calibrate*. The Calibrate menu leads you through every analog input and prompts you to apply the appropriate quantity.

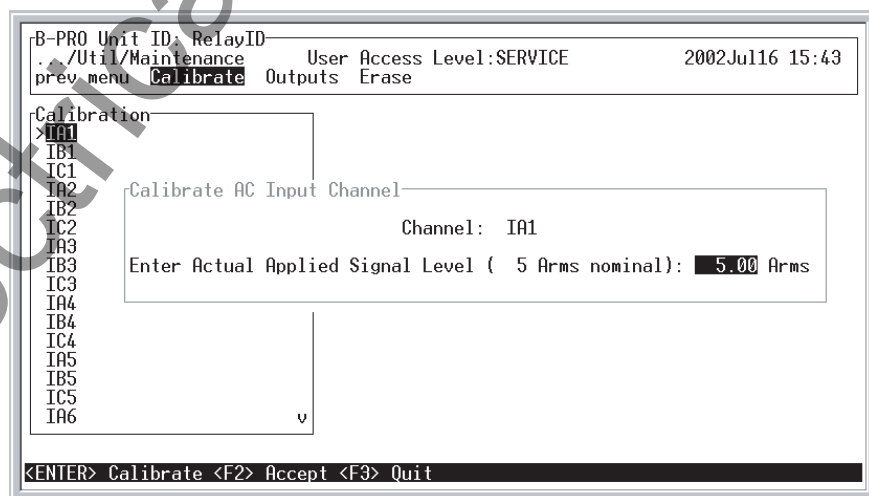

Figure 6.1: Enter actual applied signal level

```

B-PRO Unit ID: RelayID
.../Util/Maintenance      User Access Level:SERVICE      2002Jul16 15:45
prev menu Calibrate      Outputs Erase

r-Calibration
>IA1
IB1
IC1
IA2      r-Calibrate AC Input Channel
I-Status Message
I
I Calibrate error. Gain reading +0.00 out of range ( +6.40 to +9.60)
I
I
I
I
IB4
IC4
IA5
IB5
IC5
IA6
v

<ENTER> Calibrate <F2> Accept <F3> Quit

```

Figure 6.2: Calibration error - out of range

For example when you select voltage V_A for calibration, a prompt appears which asks you which quantity the relay should try to calibrate. If a 66 volt phase to neutral quantity is applied to the back V_A terminals, 66.0 volts would be indicated as the desired calibration.

In a similar way, you are prompted to go through all 21 ac analog quantities and provide the information about the injected calibration quantities. You must have a test source to perform the function. Only the magnitude of the analog input requires calibration, not the angle.

When an input analog channel is calibrated, the quantity measured you can verify it by selecting the *Metering* menu and the *Analog Quantity* submenu. V_A of the ac voltage input is used as a reference quantity by B-PRO. Therefore, if it is absent, there is not a locked, valid relationship among all of the analog quantities.

Testing the External Inputs

To test the external inputs, connect the relay to a laptop in *Terminal Mode, Service level>Metering>I/O*. This screen displays the status of the Inputs and Output Contacts. Placing a voltage of 125 Vdc nominal, (150 V maximum), to each of the external inputs in turn causes the input to change from Low to High status. These inputs are polarity sensitive and this screen has a 0.5 seconds update rate. The inputs should reset when the dc voltage drops below about 80 volts. Testing requires application of a correct voltage polarity.

Testing the Output Relay Contacts

Test the output relays to verify their integrity using the *Utilities>Maintenance>Outputs*. The output contacts are closed by pressing the *Enter* key. Toggles the output contacts from open to closed by pressing the *Enter* key. Verify the output contact status using an ohmmeter. When you exit this sub-menu, all contact status reverts to the open position

Testing the Inverse Time Overcurrent Function

Test function 51 by injecting current into the relay. The setting pickup of function 51 is done on a secondary current basis.

The equation for the IEEE overheating curves is displayed in the B-PRO *Offliner* Settings program and can be used to determine how long it takes to operate the overcurrent function for a given input current. The overcurrent curve function is equation-driven and uses fixed constants to generate the operation curves. See “50/51/67 Phase Overcurrent” on page 4-14 for details on the equations and constants.

Test the 51 reset time by using the following example and equations. Use your test software to setup an appropriate test sequence and measure time t_1 , t_x and t_2 to determine the relay’s performance with your setting parameters.

Equation 1

$$T(I) = TMS \left[\frac{TR}{\left(\frac{I}{Pickup} \right)^2 - 1} \right]$$

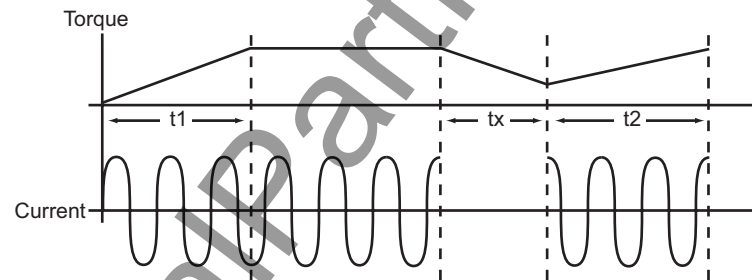

If $(t_x > t_{(I)})$ then $t_2 = t_1$

$$t_2 = \frac{t_x}{t_m} \cdot t_1$$

Where t_1 equals the time to operate for the applied current and t_m equals the value of solving Equation 1.

Testing the Loss of Potential Function

There are no user settings for device 60. If one or two of the AC voltages go below 0.5 per unit or below 33.2 volt-seconds an ac Loss Of Potential alarm will take place after a definite 10 second delay. This can be tested by dropping all combinations of one and two voltages and waiting 10 seconds

Some Additional Points to Consider

In all of the test cases, B-PRO can be set to trigger a transient fault record. Once this is done, the fault record can be viewed, as can the point where the operation point crosses into the trip region. Also, any combination of injected currents can be performed to test all the functions of the relay. That is, the differential function between HV and LV can be performed. A test using all 15 currents could be performed. This presumes that fifteen synchronized currents are available. A verification of operate IO and restraint IR quantities is possible through the TERMINAL MODE by selecting the OPERATING QUANTITIES sub-menu. This screen indicates the current pu quantity relationship within the relay.

Most protection functions also have pickup level outputs available. These can be programmed to produce outputs by enabling them in the OUTPUT MATRIX screens. These functions can be useful during testing, especially time delayed functions where the user is trying to determine where the function is starting to pickup.

B-PRO Unit ID: UnitID			
.../Metering/Analog	User Access Level: CHANGE	2004Aug05 10:19	
prev menu 87B Operating	87T Operating	Line Quantities	Analog Inputs
87B Operating			
Bus Differential (87B-1)	A Phase	B Phase	C Phase
Operating Current, IO (pu)	0.0	0.0	0.0
Restraint Current, IR (pu)	0.0	0.0	0.0
87B-1 Function Enabled			
Bus Differential (87B-2)	A Phase	B Phase	C Phase
Operating Current, IO (pu)	0.0	0.0	0.0
Restraint Current, IR (pu)	0.0	0.0	0.0
87B-2 Function Enabled			
Note: 1 pu = 50.0 MVA for both 87B-1 and 87B-2_			
<F3> Quit <F2> Freeze			

Figure 6.3: Operating Quantities

7 Installation

Physical Mounting

Standard 3U

The relay is 3 rack units or 5.25 inches high and approximately 12.25 inches deep. The standard relay is designed for a 19-inch rack. A complete mechanical drawing is shown, for details see “Mechanical Drawings” in Appendix G.

To install the relay you need the following:

- 19 inch rack
- 4 - #10 screws

AC and DC Wiring

For details see “AC Schematic Drawing” in Appendix I and “DC Schematic Drawing” in Appendix J.

Communication Wiring

EIA-232

The relay’s three serial ports (Ports 1, 2 and 3) are configured as EIA RS-232 Data Communications Equipment (DCE) devices with female DB9 connectors. This allows them to be connected directly to a PC serial port with a standard straight-through male-to-female serial cable. For pin-out details see “Communication Port Details” on page 2-8.

An adapter is available for connecting an external modem to Port 2. For details, see “Modem Link - External” on page 2-3.

RJ-45

The relay may have an optional internal modem or an optional internal 10BaseT Ethernet port. Connection to either of these is via the relay’s Port 5 RJ-45 receptacle. Labeling above the port will indicate which option, if any, has been installed.

IRIG-B Wiring

The relay accepts both modulated and unmodulated IRIG-B standard time signals with or without the IEEE 1344 extensions. The IRIG-B connector on the back of the relay is BNC type.

www.ElectricalPartManuals.com

Appendix A IED Specifications

B-PRO Model 8700/BUS Specification		
Item	Quantity/Specs	Note
General:		
Nominal Frequency	50 or 60 Hz	
Operate Time	8–20 ms for 87B function 12–24 ms for 87T function	Including relay output operation.
Sampling Rate	96 samples/cycle for recording 8 samples/cycle for protection	
Power Supply	Nominal Range: 48–250 Vdc, 120 Vac Full Operating Range: 40–300 Vdc	Battery load is 50 watts or 50VA AC current.
Memory	Settings and records are stored in non-volatile memory.	Records are stored in a circular buffer.
Protection Functions:		
IEEE Dev. 87B, 59, 27, 60, 81, 87T, 50LS, 50BF, 50/51/67, 50N/51N/67, 46-50/46-51/67	2 differential zones (bus and transformer, or Bus1 and Bus2) and overcurrent protection on each line.	15 ProLogic statements provide flexible solutions.
Recording:		
Fault	96 s/c oscillography of all analog and external input channels. Capacity: up to 15 x 2 second records	Records up to the 25th harmonic. Viewing software provides waveform, symmetrical components and harmonic analysis.
Dynamic Swing	1 s/c phasor measurements of line positive sequence V and I plus frequency Capacity: up to 15 x 3 minute records	
A/D Resolution	13 bits, 8192 counts full scale, peak-peak.	
Events	250	
Input and Output:		
Analog Input Channels	18 currents and 3 voltages	Rating: In = 5 A or 1 A Vn = 69 V Continuous: 3x In, 2x Vn One Second: 20x In without distortion One Minute: 3x Vn, once/hour
Sampling Resolution	12 bits plus sign, amplitude measurement accuracy: $\pm 0.5\%$ for 54 to 66 Hz	
Burden (Analog Inputs)	ac input voltage: $< 0.15 \text{ VA @ } 67 \text{ V}$ ac input current: $< 0.50 \text{ VA @ } 5 \text{ A}$	
Analog Input Sampling	Sample rate: 96 samples/cycle for recording, 8x/cycle for protection.	

B-PRO Model 8700/BUS Specification		
External Inputs	9 isolated inputs.	Optional 48–125 or 125–250 Vdc nominal, externally wetted.
Burden	Burden resistance: > 10 k ohms	
Isolation	Internal optical isolation	
External Input Sampling	Sample rate: 96 samples/cycle for recording, 8x/cycle for protection	
Output Relays (contacts)	14 programmable outputs plus relay inoperative contact	Make: 30 A as per IEEE C37.90 Carry: 8 A Break: 0.9 A at 125 Vdc resistive 0.35 A at 250 Vdc resistive
Interface & Communication:		
Front Display	2 lines x 24 characters, fluorescent	Exceptional visibility in all ambient light conditions.
Front Panel Indicators	6 LEDs	Target, Relay Functional, IRIG-B Functional, Service Required, Test Mode, Alarm.
Serial User Interface	Front and rear RS-232 ports to 57.6 K baud	Rear port can support an external modem
Internal Modem	33.6 Kbps, V.32 bis	Optional internal modem
Network	10 Base T Ethernet port	Optional Ethernet card
SCADA Interface	DNP3 (RS-232 or Ethernet) or Modbus (RS-232)	Rear port
Time Sync	IRIG-B, BNC connector	Modulated or unmodulated, auto-detect
Self Checking/Relay Inoperative	1 contact	Closed when relay inoperative.
Terminal User Interface	VT100 terminal emulation	Accessible via serial, modem or network interface.
Environmental:		
Ambient Temperature Range	-40°C to 85°C	IEC 60068-2-1/IEC 60068-2-2
Humidity	Up to 95% without condensation	IEC 60068-2-30
Insulation Test (Hi-Pot)	Power supply, analog inputs, external inputs, output contacts – 1.5 kV, 50/60 Hz, 1 minute.	IEC 60255-5
Electrical Fast Transient		ANSI/IEEE C37.90.1 - 1989
Oscillatory Transient		ANSI/IEEE C37.90.1 - 1989
RFI Susceptibility		ANSI/IEEE C37.90.2, IEC 255-22-3
Shock and Bump		IEC 60255-21-2 Class 1
Sinusoidal Vibration	10Hz to 150Hz, 0.15mm or 20m/s ² 10 sweep cycles	IEC 60068-2-6
Physical:		

B-PRO Model 8700/BUS Specification		
Weight	11.52 kg	25.40 lbs
Dimensions	13.3 cm	3U high, 5.25"
	48.3 cm rack mount	19" rack mount
	30.5 cm deep	12" deep
Mounting	Horizontal	
Time Synchronization and Accuracy:		
External Time Source	The B-PRO relay is synchronized using IRIG-B input (modulated or unmodulated) auto detect.	Free Running Accuracy: In the absence of an external time source, the relay maintains time with a maximum ± 15 minutes drift per year over the full operating temperature range, and maximum ± 90 seconds drift per year at a constant temperature of 25°C. The relay can detect loss or re-establishment of external time source and automatically switch between internal and external time.
Synchronization Accuracy	Sampling clocks synchronized with the time source (internal or external).	
Overall B-PRO Accuracies:		
Current	$\pm 2.5\%$ of inputs from 0.1 to 1.0 x nominal current (I_n)	
	$\pm 1.0\%$ of inputs from 1.0 to 20.0 x nominal current (I_n)	
Voltage	$\pm 1.0\%$ of inputs from 0.01 to 2.0 x nominal voltage (V_n)	
Timers	± 3 ms of set value	
Inverse Overcurrent Times	$\pm 2.5\%$ or ± 1 cycle of selected curve	
Definite Overcurrent Times	$\pm 2.5\%$ or ± 1 cycle non-directional	
	$\pm 2.5\%$ or ± 1.5 cycle directional	
Frequency Timers	± 3 ms of set value plus 1.25 cycles to 1.75 cycles of inherent delay	
Burden	AC Voltage Inputs, < 0.15 VA @ 69 volts	
	AC Current Inputs, < 0.50 VA @ 5 amps	

www.ElectricalPartManuals.com

Appendix B IED Settings and Ranges

When a setting has been completed in the B-PRO *Offliner* Settings software, it can be printed along with the ranges available for these settings. This is a view only option, that is, if the user wants to change settings they must go back into the settings portion dealing with that setting to make changes. The summary is however, a quick way of having a look at all the settings in a very compact form.

The top part of the settings summary identifies the date that the settings were done, the relay identification, the station that the relay is applied and the location.

The setting summary provides a list of all the current and voltage analog input quantity names used for line protection and used for recording. External Inputs and Output contact names are also identified on this summary.

Settings Summary - B-PRO 8700			
Name	Symbol/Value	Unit	Range
Relay Identification			
Settings Version	4		
Ignore Serial Number	No		
Serial Number	BPRO-8700-010215-01		
Nominal CT Secondary Current	5 A		
Nominal System Frequency	60 Hz		
Relay ID	RelayID		
Comments	Comments		
Date Created-Modified	2002-06-21 14:10:22		
Station Name	Station Name		
Station Number	1		
Location	Location		
Equipment Protected	Bus		
Analog Input Names			
Voltage Input Name	BUS PT 1		
VA	Voltage A		
VB	Voltage B		
VC	Voltage C		
Input 1	Input1		
IA1	Input1 Current A		
IB1	Input1 Current B		
IC1	Input1 Current C		
Input 2	Input2		
IA2	Input2 Current A		

Settings Summary - B-PRO 8700			
IB2	Input2 Current B		
IC2	Input2 Current C		
Input 3	Input3		
IA3	Input3 Current A		
IB3	Input3 Current B		
IC3	Input3 Current C		
Input 4	Input4		
IA4	Input4 Current A		
IB4	Input4 Current B		
IC4	Input4 Current C		
Input 5	Input5		
IA5	Input5 Current A		
IB5	Input5 Current B		
IC5	Input5 Current C		
Input 6	Input6		
IA6	Input6 Current A		
IB6	Input6 Current B		
IC6	Input6 Current C		
External Input Names			
1	EI Spare 1		
2	EI Spare 2		
3	EI Spare 3		
4	EI Spare 4		
5	EI Spare 5		
6	EI Spare 6		
7	EI Spare 7		
8	EI Spare 8		
9	EI Spare 9		
Output Contact Names			
Output 1	Out Spare 1		
Output 2	Out Spare 2		
Output 3	Out Spare 3		
Output 4	Out Spare 4		
Output 5	Out Spare 5		
Output 6	Out Spare 6		
Output 7	Out Spare 7		
Output 8	Out Spare 8		
Output 9	Out Spare 9		
Output 10	Out Spare 10		

Settings Summary - B-PRO 8700			
Output 11	Out Spare 11		
Output 12	Out Spare 12		
Output 13	Out Spare 13		
Output 14	Out Spare 14		
System Parameters			
Bus 1 MVA	100.0	MVA Primary	1.0 to 1000.0
Bus 2 MVA	100.0	MVA Primary	1.0 to 1000.0
Bus Voltage	230.0	kV Primary	1.0 to 1000.0
PT Turns Ratio	10000.0	:1	1.0 to 10000.0
Phase Rotation	ABC		
Directional Control Alpha	0.0	degrees	-179.9 to 180.0
Directional Control Beta	180.0	degrees	0.1 to 360.0
Winding/CT Connections			
Differential Zone	Bus only		
Bus side:			
Voltage	230.0	kV Primary	1.0 to 1000.0
Connection	Y		
Phase	0° degree ref (fixed)		
Non-Bus side:			
Voltage	115.0	kV Primary	1.0 to 1000.0
Connection	Y		
Phase	0°		
Transformer 3 Phase MVA	60.0	MVA Primary	1.0 to 2000.0
CT Connections			
Input 1 [Input1]			
Connect to	Bus		
CT Connection	Y (fixed)		
CT Phase	0° (fixed)		
CT Turns Ratio (to 1)	100.0	:1	-
Digital Control	Enabled		
Digital Control Selection	Not Used		
Exclude When	High		
Input 2 [Input2]			
Connect to	Bus		
CT Connection	Y (fixed)		
CT Phase	0° (fixed)		
CT Turns Ratio (to 1)	100.0	:1	-
Digital Control	Enabled		
Digital Control Selection	Not Used		

Settings Summary - B-PRO 8700			
Exclude When	High		
Input 3 [Input3]			
Connect to	Bus		
CT Connection	Y (fixed)		
CT Phase	0° (fixed)		
CT Turns Ratio (to 1)	100.0	:1	
Digital Control	Enabled		
Digital Control Selection	Not Used		
Exclude When	High		
Input 4 [Input4]			
Connect to	Bus		
CT Connection	Y (fixed)		
CT Phase	0° (fixed)		
CT Turns Ratio (to 1)	100.0	:1	-
Digital Control	Enabled		
Digital Control Selection	Not Used		
Exclude When	High		
Input 5 [Input5]			
Connect to	Bus		
CT Connection	Y (fixed)		
CT Phase	0° (fixed)		
CT Turns Ratio (to 1)	100.0	:1	-
Digital Control	Enabled		
Digital Control Selection	Not Used		
Exclude When	High		
Input 6 [Input6]			
Connect to	Bus		
CT Connection	Y		
CT Phase	0°		
CT Turns Ratio (to 1)	100.0	:1	-
Digital Control	Enabled		
Digital Control Selection	Not Used		
Exclude When	High		
Protection Summary			
87B	Enabled		
87T	Disabled		
60	Enabled		
27-1	Enabled		
27-2	Enabled		

Settings Summary - B-PRO 8700			
59-1	Enabled		
59-2	Enabled		
81 O/F-1	Enabled		
81 O/F-2	Enabled		
81 U/F-1	Enabled		
81 U/F-2	Enabled		
Input 1 [Input1] Protection			
50BF	Enabled		
50LS-1	Enabled		
50LS-2	Enabled		
50	Enabled		
51	Enabled		
50N	Enabled		
51N	Enabled		
46-50	Enabled		
46-51	Enabled		
Input 2 [Input2] Protection			
50BF	Disabled		
50LS-1	Disabled		
50LS-2	Disabled		
50	Disabled		
51	Disabled		
50N	Disabled		
51N	Disabled		
46-50	Disabled		
46-51	Disabled		
Input 3 [Input3] Protection			
50BF	Disabled		
50LS-1	Disabled		
50LS-2	Disabled		
50	Disabled		
51	Disabled		
50N	Disabled		
51N	Disabled		
46-50	Disabled		
46-51	Disabled		
Input 4 [Input4] Protection			
50BF	Disabled		
50LS-1	Disabled		

Settings Summary - B-PRO 8700			
50LS-2	Disabled		
50	Disabled		
51	Disabled		
50N	Disabled		
51N	Disabled		
46-50	Disabled		
46-51	Disabled		
Input 5 [Input5] Protection			
50BF	Disabled		
50LS-1	Disabled		
50LS-2	Disabled		
50	Disabled		
51	Disabled		
50N	Disabled		
51N	Disabled		
46-50	Disabled		
46-51	Disabled		
Input 6 [Input6] Protection			
50BF	Disabled		
50LS-1	Disabled		
50LS-2	Disabled		
50	Disabled		
51	Disabled		
50N	Disabled		
51N	Disabled		
46-50	Disabled		
46-51	Disabled		
87B-1 - Bus Differential			
87B-1	Enabled		
IOmin	0.25	p. u.	0.20 to 0.40
IRs	2.00	p. u.	1.25 to 50.00
S1	20.00	%	12.50 to 40.00
S2	40.00	%	30.00 to 200.00
High Curr. Setting	10.00	p. u.	0.75 to 100.00
CT Saturation Detection	Disabled		
CT Saturation Max Block	1.00	-	0.10 to 99.99
87B-2 - Bus Differential			
87B-2	Enabled		
IOmin	0.25	p. u.	0.20 to 0.40

Settings Summary - B-PRO 8700			
IRs	2.00	p. u.	1.25 to 50.00
S1	20.00	%	12.50 to 40.00
S2	40.00	%	30.00 to 200.00
High Curr. Setting	10.00	p. u.	0.75 to 100.00
CT Saturation Detection	Disabled		
CT Saturation Max Block	1.00	-	0.10 to 99.99
87T - Transformer Differential			
87T	Disabled		
IOmin	0.25	p. u.	0.10 to 0.40
IRs	2.00	p. u.	1.25 to 50.00
S1	20.00	%	12.50 to 40.00
S2	40.00	%	30.00 to 200.00
High Curr. Setting	10.00	p. u.	0.75 to 100.00
I _{2nd} / I _{fund} Ratio	0.20	-	0.05 to 1.00
I _{5th} Harmonic Restraint	Disabled		
I _{5th} / I _{fund} Ratio	0.20	-	0.05 to 1.00
27 - Undervoltage			
27-1	Enabled		
Gate Switch	OR		
Pickup	20.0	volts	1.0 to 120.0
Pickup Delay	1.00	seconds	0.00 to 99.99
27-2	Enabled		
Gate Switch	OR		
Pickup	20.0	volts	1.0 to 120.0
Pickup Delay	1.00	seconds	0.00 to 99.99
59 - Overvoltage			
59-1	Enabled		
Gate Switch	OR		
Pickup	70.0	volts	60.0 to 140.0
Pick-up Delay	1.00	seconds	0.00 to 99.99
59-2	Enabled		
Gate Switch	OR		
Pickup	70.0	volts	60.0 to 140.0
Pickup Delay	1.00	seconds	0.00 to 99.99
60 - Loss of Potential Alarm			
60	Enabled		
81 - Over-Frequency			
81 O/F-1	Enabled		
Pickup	61.00	Hz	60.00 to 70.00

Settings Summary - B-PRO 8700			
Pickup Delay	2.00	seconds	0.05 to 99.99
81 O/F-2	Enabled		
Pickup	62.00	Hz	60.00 to 70.00
Pickup Delay	2.00	seconds	0.05 to 99.99
81 - Under-Frequency			
81 U/F-1	Enabled		
Pickup	59.50	Hz	50.00 to 60.00
Pickup Delay	2.00	seconds	0.05 to 99.99
81 U/F-2	Enabled		
Pickup	59.00	Hz	50.00 to 60.00
Pickup Delay	2.00	seconds	0.05 to 99.99
Input 1 [Input1], 50BF - Breaker Failure			
50BF	Enabled		
BF Initiated By 87B-1	Disabled		
BF Initiated By 87B-2	Disabled		
BF Initiated By 87T	Disabled		
BF Initiated By ProLogic	Disabled		
BF Initiated By Ext. Input	Disabled		
Pickup Delay 1	0.50	seconds	0.01 to 99.99
Pickup Delay 2	1.50	seconds	0.01 to 99.99
Input 1 [Input1], 50LS - Low Set Overcurrent			
50LS-1	Enabled		
Gate Switch	OR		
Pickup	1.0	amperes	0.1 to 50.0
Pickup Delay	0.00	seconds	0.00 to 99.99
50LS-2	Enabled		
Gate Switch	OR		
Pickup	1.0	amperes	0.1 to 50.0
Pickup Delay	0.00	seconds	0.00 to 99.99
Input 1 [Input1], 50/51/67 - Phase Overcurrent			
50	Enabled		
Directional Control	forward		
Pickup	10.0	amperes	0.5 to 50.0
Pickup Delay	1.00	amperes	0.00 to 99.99
Breaker Failure Initiated	Disabled		
51	Enabled		
Directional Control	forward		
Pickup	10.0	amperes	0.5 to 50.0

Settings Summary - B-PRO 8700			
Breaker Failure Initiated	Disabled		
Curve Type	IEC very inverse		
A	13.5	-	-
B	0.0	-	-
p	1.0	-	-
TR	47.30	-	-
TMS	0.50	-	0.01 to 10.00
Input 1 [Input1], 50N/51N/67 - Neutral Overcurrent			
50N	Enabled		
Directional Control	forward		
Pickup	10.0	amperes	0.5 to 50.0
Pickup Delay	1.00	amperes	0.00 to 99.99
Breaker Failure Initiated	Disabled		
51N	Enabled		
Directional Control	forward		
Pickup	10.0	amperes	0.5 to 50.0
Breaker Failure Initiated	Disabled		
Curve Type	IEC very inverse		
A	13.5	-	-
B	0.0	-	-
p	1.0	-	-
TR	47.30	-	-
TMS	0.50	-	0.01 to 10.00
Input 1 [Input1], 46-50/46-51/67 - Negative Sequence Overcurrent			
46-50	Enabled		
Directional Control	forward		
Pickup	10.0	amperes	0.5 to 50.0
Pickup Delay	1.00	amperes	0.00 to 99.99
Breaker Failure Initiated	Disabled		
46-51	Enabled		
Directional Control	forward		
Pickup	10.0	amperes	0.5 to 50.0
Breaker Failure Initiated	Disabled		
Curve Type	IEC very inverse		
A	13.5	-	-
B	0.0	-	-
p	1.0	-	-
TR	47.30	-	-

Settings Summary - B-PRO 8700			
TMS	0.50	-	0.01 to 10.00
Input 2 [Input2], 50BF - Breaker Failure			
50BF	Disabled		
BF Initiated By 87B-1	Disabled		
BF Initiated By 87B-2	Disabled		
BF Initiated By 87T	Disabled		
BF Initiated By ProLogic	Disabled		
BF Initiated By Ext. Input	Disabled		
Pickup Delay 1	0.50	seconds	0.01 to 99.99
Pickup Delay 2	1.50	seconds	0.01 to 99.99
Input 2 [Input2], 50LS - Low Set Overcurrent			
50LS-1	Disabled		
Gate Switch	OR		
Pickup	1.0	amperes	0.1 to 50.0
Pickup Delay	0.00	seconds	0.00 to 99.99
50LS-2	Disabled		
Gate Switch	OR		
Pickup	1.0	amperes	0.1 to 50.0
Pickup Delay	0.00	seconds	0.00 to 99.99
Input 2 [Input2], 50/51/67 - Phase Overcurrent			
50	Disabled		
Directional Control	forward		
Pickup	10.0	amperes	0.5 to 50.0
Pickup Delay	1.00	amperes	0.00 to 99.99
Breaker Failure Initiated	Disabled		
51	Disabled		
Directional Control	forward		
Pickup	10.0	amperes	0.5 to 50.0
Breaker Failure Initiated	Disabled		
Curve Type	IEC very inverse		
A	13.5	-	-
B	0.0	-	-
p	1.0	-	-
TR	47.30	-	-
TMS	0.50	-	0.01 to 10.00
Input 2 [Input2], 50N/51N/67 - Neutral Overcurrent			
50N	Disabled		

Settings Summary - B-PRO 8700			
Directional Control	forward		
Pickup	10.0	amperes	0.5 to 50.0
Pickup Delay	1.00	amperes	0.00 to 99.99
Breaker Failure Initiated	Disabled		
51N	Disabled		
Directional Control	forward		
Pickup	10.0	amperes	0.5 to 50.0
Breaker Failure Initiated	Disabled		
Curve Type	IEC very inverse		
A	13.5	-	-
B	0.0	-	-
p	1.0	-	-
TR	47.30	-	-
TMS	0.50	-	0.01 to 10.00
Input 2 [Input2], 46-50/46-51/67 - Negative Sequence Overcurrent			
46-50	Disabled		
Directional Control	forward		
Pickup	10.0	amperes	0.5 to 50.0
Pickup Delay	1.00	amperes	0.00 to 99.99
Breaker Failure Initiated	Disabled		
46-51	Disabled		
Directional Control	forward		
Pickup	10.0	amperes	0.5 to 50.0
Breaker Failure Initiated	Disabled		
Curve Type	IEC very inverse		
A	13.5	-	-
B	0.0	-	-
p	1.0	-	-
TR	47.30	-	-
TMS	0.50	-	0.01 to 10.00
Input 3 [Input3], 50BF - Breaker Failure			
50BF	Disabled		
BF Initiated By 87B-1	Disabled		
BF Initiated By 87B-2	Disabled		
BF Initiated By 87T	Disabled		
BF Initiated By ProLogic	Disabled		
BF Initiated By Ext. Input	Disabled		
Pickup Delay 1	0.50	seconds	0.01 to 99.99

Settings Summary - B-PRO 8700			
Pickup Delay 2	1.50	seconds	0.01 to 99.99
Input 3 [Input3], 50LS - Low Set Overcurrent			
50LS-1	Disabled		
Gate Switch	OR		
Pickup	1.0	amperes	0.1 to 50.0
Pickup Delay	0.00	seconds	0.00 to 99.99
50LS-2	Disabled		
Gate Switch	OR		
Pickup	1.0	amperes	0.1 to 50.0
Pickup Delay	0.00	seconds	0.00 to 99.99
Input 3 [Input3], 50/51/67 - Phase Overcurrent			
50	Disabled		
Directional Control	forward		
Pickup	10.0	amperes	0.5 to 50.0
Pickup Delay	1.00	amperes	0.00 to 99.99
Breaker Failure Initiated	Disabled		
51	Disabled		
Directional Control	forward		
Pickup	10.0	amperes	0.5 to 50.0
Breaker Failure Initiated	Disabled		
Curve Type	IEC very inverse		
A	13.5	-	-
B	0.0	-	-
p	1.0	-	-
TR	47.30	-	-
TMS	0.50	-	0.01 to 10.00
Input 3 [Input3], 50N/51N/67 - Neutral Overcurrent			
50N	Disabled		
Directional Control	forward		
Pickup	10.0	amperes	0.5 to 50.0
Pickup Delay	1.00	amperes	0.00 to 99.99
Breaker Failure Initiated	Disabled		
51N	Disabled		
Directional Control	forward		
Pickup	10.0	amperes	0.5 to 50.0
Breaker Failure Initiated	Disabled		
Curve Type	IEC very inverse		

Settings Summary - B-PRO 8700			
A	13.5	-	-
B	0.0	-	-
p	1.0	-	-
TR	47.30	-	-
TMS	0.50	-	0.01 to 10.00
Input 3 [Input3], 46-50/46-51/67 - Negative Sequence Overcurrent			
46-50	Disabled		
Directional Control	forward		
Pickup	10.0	amperes	0.5 to 50.0
Pickup Delay	1.00	amperes	0.00 to 99.99
Breaker Failure Initiated	Disabled		
46-51			
Directional Control	forward		
Pickup	10.0	amperes	0.5 to 50.0
Breaker Failure Initiated	Disabled		
Curve Type	IEC very inverse		
A	13.5	-	-
B	0.0	-	-
p	1.0	-	-
TR	47.30	-	-
TMS	0.50	-	0.01 to 10.00
Input 4 [Input4], 50BF - Breaker Failure			
50BF	Disabled		
BF Initiated By 87B-1	Disabled		
BF Initiated By 87B-2	Disabled		
BF Initiated By 87T	Disabled		
BF Initiated By ProLogic	Disabled		
BF Initiated By Ext. Input	Disabled		
Pickup Delay 1	0.50	seconds	0.01 to 99.99
Pickup Delay 2	1.50	seconds	0.01 to 99.99
Input 4 [Input4], 50LS - Low Set Overcurrent			
50LS-1	Disabled		
Gate Switch	OR		
Pickup	1.0	amperes	0.1 to 50.0
Pickup Delay	0.00	seconds	0.00 to 99.99
50LS-2			
Gate Switch	OR		
Pickup	1.0	amperes	0.1 to 50.0

Settings Summary - B-PRO 8700			
Pickup Delay	0.00	seconds	0.00 to 99.99
Input 4 [Input4], 50/51/67 - Phase Overcurrent			
50	Disabled		
Directional Control	forward		
Pickup	10.0	amperes	0.5 to 50.0
Pickup Delay	1.00	amperes	0.00 to 99.99
Breaker Failure Initiated	Disabled		
51	Disabled		
Directional Control	forward		
Pickup	10.0	amperes	0.5 to 50.0
Breaker Failure Initiated	Disabled		
Curve Type	IEC very inverse		
A	13.5	-	-
B	0.0	-	-
p	1.0	-	-
TR	47.30	-	-
TMS	0.50	-	0.01 to 10.00
Input 4 [Input4], 50N/51N/67 - Neutral Overcurrent			
50N	Disabled		
Directional Control	forward		
Pickup	10.0	amperes	0.5 to 50.0
Pickup Delay	1.00	amperes	0.00 to 99.99
Breaker Failure Initiated	Disabled		
51N	Disabled		
Directional Control	forward		
Pickup	10.0	amperes	0.5 to 50.0
Breaker Failure Initiated	Disabled		
Curve Type	IEC very inverse		
A	13.5	-	-
B	0.0	-	-
p	1.0	-	-
TR	47.30	-	-
TMS	0.50	-	0.01 to 10.00
Input 4 [Input4], 46-50/46-51/67 - Negative Sequence Overcurrent			
46-50	Disabled		
Directional Control	forward		
Pickup	10.0	amperes	0.5 to 50.0

Settings Summary - B-PRO 8700			
Pickup Delay	1.00	amperes	0.00 to 99.99
Breaker Failure Initiated	Disabled		
46-51	Disabled		
Directional Control	forward		
Pickup	10.0	amperes	0.5 to 50.0
Breaker Failure Initiated	Disabled		
Curve Type	IEC very inverse		
A	13.5	-	-
B	0.0	-	-
p	1.0	-	-
TR	47.30	-	-
TMS	0.50		0.01 to 10.00
Input 5 [Input5], 50BF - Breaker Failure			
50BF	Disabled		
BF Initiated By 87B-1	Disabled		
BF Initiated By 87B-2	Disabled		
BF Initiated By 87T	Disabled		
BF Initiated By ProLogic	Disabled		
BF Initiated By Ext. Input	Disabled		
Pickup Delay 1	0.50	seconds	0.01 to 99.99
Pickup Delay 2	1.50	seconds	0.01 to 99.99
Input 5 [Input5], 50LS - Low Set Overcurrent			
50LS-1	Disabled		
Gate Switch	OR		
Pickup	1.0	amperes	0.1 to 50.0
Pickup Delay	0.00	seconds	0.00 to 99.99
50LS-2	Disabled		
Gate Switch	OR		
Pickup	1.0	amperes	0.1 to 50.0
Pickup Delay	0.00	seconds	0.00 to 99.99
Input 5 [Input5], 50/51/67 - Phase Overcurrent			
50	Disabled		
Directional Control	forward		
Pickup	10.0	amperes	0.5 to 50.0
Pickup Delay	1.00	amperes	0.00 to 99.99
Breaker Failure Initiated	Disabled		
51	Disabled		
Directional Control	forward		

Settings Summary - B-PRO 8700			
Pickup	10.0	amperes	0.5 to 50.0
Breaker Failure Initiated	Disabled		
Curve Type	IEC very inverse		
A	13.5	-	-
B	0.0	-	-
p	1.0	-	-
TR	47.30	-	-
TMS	0.50	-	0.01 to 10.00
Input 5 [Input5], 50N/51N/67 - Neutral Overcurrent			
50N	Disabled		
Directional Control	forward		
Pickup	10.0	amperes	0.5 to 50.0
Pickup Delay	1.00	amperes	0.00 to 99.99
Breaker Failure Initiated	Disabled		
51N	Disabled		
Directional Control	forward		
Pickup	10.0	amperes	0.5 to 50.0
Breaker Failure Initiated	Disabled		
Curve Type	IEC very inverse		
A	13.5	-	-
B	0.0	-	-
p	1.0	-	-
TR	47.30	-	-
TMS	0.50	-	0.01 to 10.00
Input 5 [Input5], 46-50/46-51/67 - Negative Sequence Overcurrent			
46-50	Disabled		
Directional Control	forward		
Pickup	10.0	amperes	0.5 to 50.0
Pickup Delay	1.00	amperes	0.00 to 99.99
Breaker Failure Initiated	Disabled		
46-51	Disabled		
Directional Control	forward		
Pickup	10.0	amperes	0.5 to 50.0
Breaker Failure Initiated	Disabled		
Curve Type	IEC very inverse		
A	13.5	-	-
B	0.0	-	-
p	1.0	-	-

Settings Summary - B-PRO 8700			
TR	47.30	-	-
TMS	0.50	-	0.01 to 10.00
Input 6 [Input6], 50BF - Breaker Failure			
50BF	Disabled		
BF Initiated By 87B-1	Disabled		
BF Initiated By 87B-2	Disabled		
BF Initiated By 87T	Disabled		
BF Initiated By ProLogic	Disabled		
BF Initiated By Ext. Input	Disabled		
Pickup Delay 1	0.50	seconds	0.01 to 99.99
Pickup Delay 2	1.50	seconds	0.01 to 99.99
Input 6 [Input6], 50LS - Low Set Overcurrent			
50LS-1	Disabled		
Gate Switch	OR		
Pickup	1.0	amperes	0.1 to 50.0
Pickup Delay	0.00	seconds	0.00 to 99.99
50LS-2	Disabled		
Gate Switch	OR		
Pickup	1.0	amperes	0.1 to 50.0
Pickup Delay	0.00	seconds	0.00 to 99.99
Input 6 [Input6], 50/51/67 - Phase Overcurrent			
50	Disabled		
Directional Control	forward		
Pickup	10.0	amperes	0.5 to 50.0
Pickup Delay	1.00	amperes	0.00 to 99.99
Breaker Failure Initiated	Disabled		
51	Disabled		
Directional Control	forward		
Pickup	10.0	amperes	0.5 to 50.0
Breaker Failure Initiated	Disabled		
Curve Type	IEC very inverse		
A	13.5	-	-
B	0.0	-	-
p	1.0	-	-
TR	47.30	-	-
TMS	0.50	-	0.01 to 10.00
Input 6 [Input6], 50N/51N/67 - Neutral Overcurrent			

Settings Summary - B-PRO 8700			
50N	Disabled		
Directional Control	forward		
Pickup	10.0	amperes	0.5 to 50.0
Pickup Delay	1.00	amperes	0.00 to 99.99
Breaker Failure Initiated	Disabled		
51N	Disabled		
Directional Control	forward		
Pickup	10.0	amperes	0.5 to 50.0
Breaker Failure Initiated	Disabled		
Curve Type	IEC very inverse		
A	13.5	-	-
B	0.0	-	-
p	1.0	-	-
TR	47.30	-	-
TMS	0.50	-	0.01 to 10.00
Input 6 [Input6], 46-50/46-51/67 - Negative Sequence Overcurrent			
46-50	Disabled		
Directional Control	forward		
Pickup	10.0	amperes	0.5 to 50.0
Pickup Delay	1.00	amperes	0.00 to 99.99
Breaker Failure Initiated	Disabled		
46-51	Disabled		
Directional Control	forward		
Pickup	10.0	amperes	0.5 to 50.0
Breaker Failure Initiated	Disabled		
Curve Type	IEC very inverse		
A	13.5	-	-
B	0.0	-	-
p	1.0	-	-
TR	47.30	-	-
TMS	0.50	-	0.01 to 10.00
Record Length			
Fault Record Length	0.5	seconds	0.2 to 2.0
PL 1 [ProLogic 1]			
ProLogic 1	Disabled		
Target	Enabled		
Pickup Delay	0.00	seconds	0.00 to 999.00
Dropout Delay	0.00	seconds	0.00 to 999.00

Settings Summary - B-PRO 8700			
Operator 1			
Input A	<Not Used>		
Operator 2			
Input B	<Not Used>		
Operator 3			
Input C	<Not Used>		
Operator 4			
Input D	<Not Used>		
Operator 5			
Input E	<Not Used>		
PL 2 [ProLogic 2]			
ProLogic 2	Disabled		
Target	Enabled		
Pickup Delay	0.00	seconds	0.00 to 999.00
Dropout Delay	0.00	seconds	0.00 to 999.00
Operator 1			
Input A	<Not Used>		
Operator 2			
Input B	<Not Used>		
Operator 3			
Input C	<Not Used>		
Operator 4			
Input D	<Not Used>		
Operator 5			
Input E	<Not Used>		
PL 3 [ProLogic 3]			
ProLogic 3	Disabled		
Target	Enabled		
Pickup Delay	0.00	seconds	0.00 to 999.00
Dropout Delay	0.00	seconds	0.00 to 999.00
Operator 1			
Input A	<Not Used>		
Operator 2			
Input B	<Not Used>		
Operator 3			
Input C	<Not Used>		
Operator 4			
Input D	<Not Used>		
Operator 5			

Settings Summary - B-PRO 8700			
Input E	<Not Used>		
PL 4 [ProLogic 4]			
ProLogic 4	Disabled		
Target	Enabled		
Pickup Delay	0.00	seconds	0.00 to 999.00
Dropout Delay	0.00	seconds	0.00 to 999.00
Operator 1			
Input A	<Not Used>		
Operator 2			
Input B	<Not Used>		
Operator 3			
Input C	<Not Used>		
Operator 4			
Input D	<Not Used>		
Operator 5			
Input E	<Not Used>		
PL 5 [ProLogic 5]			
ProLogic 5	Disabled		
Target	Enabled		
Pickup Delay	0.00	seconds	0.00 to 999.00
Dropout Delay	0.00	seconds	0.00 to 999.00
Operator 1			
Input A	<Not Used>		
Operator 2			
Input B	<Not Used>		
Operator 3			
Input C	<Not Used>		
Operator 4			
Input D	<Not Used>		
Operator 5			
Input E	<Not Used>		
PL 6 [ProLogic 6]			
ProLogic 6	Disabled		
Target	Enabled		
Pickup Delay	0.00	seconds	0.00 to 999.00
Dropout Delay	0.00	seconds	0.00 to 999.00
Operator 1			
Input A	<Not Used>		
Operator 2			

Settings Summary - B-PRO 8700			
Input B	<Not Used>		
Operator 3			
Input C	<Not Used>		
Operator 4			
Input D	<Not Used>		
Operator 5			
Input E	<Not Used>		
PL 7 [ProLogic 7]			
ProLogic 7	Disabled		
Target	Enabled		
Pickup Delay	0.00	seconds	0.00 to 999.00
Dropout Delay	0.00	seconds	0.00 to 999.00
Operator 1			
Input A	<Not Used>		
Operator 2			
Input B	<Not Used>		
Operator 3			
Input C	<Not Used>		
Operator 4			
Input D	<Not Used>		
Operator 5			
Input E	<Not Used>		
PL 8 [ProLogic 8]			
ProLogic 8	Disabled		
Target	Enabled		
Pickup Delay	0.00	seconds	0.00 to 999.00
Dropout Delay	0.00	seconds	0.00 to 999.00
Operator 1			
Input A	<Not Used>		
Operator 2			
Input B	<Not Used>		
Operator 3			
Input C	<Not Used>		
Operator 4			
Input D	<Not Used>		
Operator 5			
Input E	<Not Used>		
PL 9 [ProLogic 9]			
ProLogic 9	Disabled		

Settings Summary - B-PRO 8700			
Target	Enabled		
Pickup Delay	0.00	seconds	0.00 to 999.00
Dropout Delay	0.00	seconds	0.00 to 999.00
Operator 1			
Input A	<Not Used>		
Operator 2			
Input B	<Not Used>		
Operator 3			
Input C	<Not Used>		
Operator 4			
Input D	<Not Used>		
Operator 5			
Input E	<Not Used>		
PL 10 [ProLogic 10]			
ProLogic 10	Disabled		
Target	Enabled		
Pickup Delay	0.00	seconds	0.00 to 999.00
Dropout Delay	0.00	seconds	0.00 to 999.00
Operator 1			
Input A	<Not Used>		
Operator 2			
Input B	<Not Used>		
Operator 3			
Input C	<Not Used>		
Operator 4			
Input D	<Not Used>		
Operator 5			
Input E	<Not Used>		
PL 11 [ProLogic 11]			
ProLogic 11	Disabled		
Target	Enabled		
Pickup Delay	0.00	seconds	0.00 to 999.00
Dropout Delay	0.00	seconds	0.00 to 999.00
Operator 1			
Input A	<Not Used>		
Operator 2			
Input B	<Not Used>		
Operator 3			
Input C	<Not Used>		

Settings Summary - B-PRO 8700			
Operator 4			
Input D	<Not Used>		
Operator 5			
Input E	<Not Used>		
PL 12 [ProLogic 12]			
ProLogic 12	Disabled		
Target	Enabled		
Pickup Delay	0.00	seconds	0.00 to 999.00
Dropout Delay	0.00	seconds	0.00 to 999.00
Operator 1			
Input A	<Not Used>		
Operator 2			
Input B	<Not Used>		
Operator 3			
Input C	<Not Used>		
Operator 4			
Input D	<Not Used>		
Operator 5			
Input E	<Not Used>		
PL 13 [ProLogic 13]			
ProLogic 13	Disabled		
Target	Enabled		
Pickup Delay	0.00	seconds	0.00 to 999.00
Dropout Delay	0.00	seconds	0.00 to 999.00
Operator 1			
Input A	<Not Used>		
Operator 2			
Input B	<Not Used>		
Operator 3			
Input C	<Not Used>		
Operator 4			
Input D	<Not Used>		
Operator 5			
Input E	<Not Used>		
PL 14 [ProLogic 14]			
ProLogic 14	Disabled		
Target	Enabled		
Pickup Delay	0.00	seconds	0.00 to 999.00
Dropout Delay	0.00	seconds	0.00 to 999.00

Settings Summary - B-PRO 8700			
Operator 1			
Input A	<Not Used>		
Operator 2			
Input B	<Not Used>		
Operator 3			
Input C	<Not Used>		
Operator 4			
Input D	<Not Used>		
Operator 5			
Input E	<Not Used>		
PL 15 [ProLogic 15]			
ProLogic 15	Disabled		
Target	Enabled		
Pickup Delay	0.00	seconds	0.00 to 999.00
Dropout Delay	0.00	seconds	0.00 to 999.00
Operator 1			
Input A	<Not Used>		
Operator 2			
Input B	<Not Used>		
Operator 3			
Input C	<Not Used>		
Operator 4			
Input D	<Not Used>		
Operator 5			
Input E	<Not Used>		

Appendix C Hardware Description

The B-PRO is a complete bus and transformer protection relay package designed and manufactured with high quality features and components.

External Input and Comm Board

The B-PRO relay has 9 channels of external input provided by the External Input and Comm Board. Inputs are optically isolated, factory preset to the customer's requested voltage level. Two dual-range user-selectable external-input voltage-level model of the External Input and Comm Board are available. This allows you to select between 48 Vdc and 125 Vdc or 125 Vdc and 250 Vdc (nominal) on a per-input basis.

The External Input and Comm Board also provides the B-PRO relay with two rear-panel RS-232 ports, IRIG-B time synchronization input, and optional network or telephone connection. The RS-232 ports are female DB-9S connectors, IRIG-B is a male BNC, and network or telephone is a female RJ-45 modular jack. A high-speed DSP communications port is also provided as a DB-15S, for future use.

Relay Output Board

The Relay Output Board provides 14 normally open contact outputs for relaying, alarms and control, 1 normally closed output contact for indicating proper relay operation.

Power Supply Board

The power supply operates from 40 to 300 Vdc or 120 Vac \pm 20% at 50/60 HZ. This wide operating range provides easier installation by eliminating power supply ordering options.

AC Analog Input Board

The AC Analog Input Board has 18 current transformer inputs and 3 potential transformer inputs for ac current and voltage inputs. On-board anti-aliasing filters provide accurate and secure digitization of the ac input signals.

Main Processor Board (MPB)

The MPB has analog data acquisition, high-speed digital signal processing for triggering and data conversion, communications, and interface logic, to perform the core functions of the B-PRO relay.

The Digital Signal Processor (DSP) on a MPB performs the protective relaying functions of the B-PRO, separate from the 486 CPU. It has its own flash memory and self-checking, for fully independent operation.

The Main Processor Board has:

- 24 channels of high-speed 12 bit-plus-sign analog-to-digital conversion
- Re-programmable flash memory for the DSP, allows independent relay operation and field software upgrades. Settings stored in non-volatile memory.
- Floating point DSP for fast capture and manipulation of data
- Standard RS-232 serial communications ports
- High speed link between DSP and 486 processors
- Time synchronism processor with automatic detection of modulated and unmodulated IRIG-B
- Sophisticated fault detection and “watchdog” recovery hardware

486 CPU Board

A 486-class CPU with 16 MB of RAM provides data storage, information management, housekeeping, and communications for the B-PRO. The 486 runs a real-time operating system optimized for high speed, high precision computing. The 486 provides sophisticated facilities for communications and field software updates. Local and wide area networking is supported by providing the B-PRO with a path to future networking capability.

A highly reliable solid-state flash disk on the CPU board provides the operating software for the 486, and stores the B-PRO's recordings.

Front Panel Board

The Front Panel Board provides visual indication of the status of the B-PRO relay, an alphanumeric display and keypad for system monitoring, and a front-panel RS-232 port.

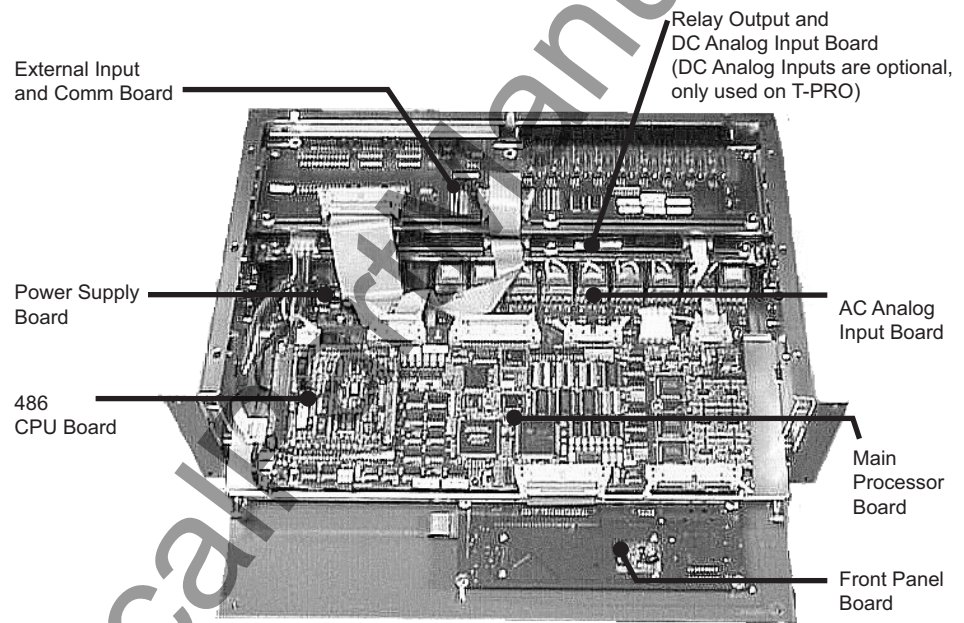

Appendix D Event Messages

B-PRO Event Messages	
Event Message	Notes
(Input Name) 50LS-1 ABC High	The possible phase information will be A, B, C, AB, BC, CA, ABC
(Input Name) 50LS-2 ABC High	
(Input Name) 50BF-1 ABC Trip	
(Input Name) 50BF-2 ABC Trip	
(Input Name) 50 on ABC Trip	
(Input Name) 51 on ABC Alarm	
(Input Name) 51 on ABC Trip	
(Input Name) 50N Trip	
(Input Name) 51N Alarm	
(Input Name) 51N Trip	
(Input Name) 46-50 Trip	
(Input Name) 46-51 Alarm	
(Input Name) 46-51 Trip	The possible phase information will be A, B, C, AB, BC, CA, ABC. (IOH) will be added into the message if the setting has been exceeded
87T Trip (IOH) on ABC	
87B-1 Trip (IOH) on ABC	
87B-2 Trip (IOH) on ABC	
87B-1 Block via CT Sat	
87B-2 Block via CT Sat	The possible phase information will be A, B, C, AB, BC, CA, ABC
59 O/V-1 on ABC: Trip	
59 O/V-2 on ABC: Trip	
27 U/V-1 on ABC: Trip	
27 U/V-2 on ABC: Trip	
60 on phase ABC: Alarm	
81 O/F-1 Trip	
81 O/F-2 Trip	
81 U/F-1 Trip	
81 U/F-2 Trip	
(ProLogic Name): PL (1–15)	ProLogic names are user-defined
(Ext. Input Name): EI (1–9): status	External input names are user-defined. Status can be "High" or "low"

(Virtual Inputs Name): VI (1-30): status	Virtual input names are user-defined. Status can be "High" or "low"
Self Check: DC Ch.n: Alarm	Continuous dc level on Ch. n, where n=1 to 18.
Self Check: DC Alarm Reset	Continuous dc level, condition has reset.
Self Check: DC Ch. n: O/P Block	Continuous dc level on Ch. n, where n=1 to 18. Relay is blocked.
New Setting Loaded	
Manual Settings Load request	Manual or user-initiated settings change
Manual Settings Load request completed	Completion of user-initiated settings change.
Unit Recalibrated	
Unit Restarted	
User logged In	

Details of Failure Modes

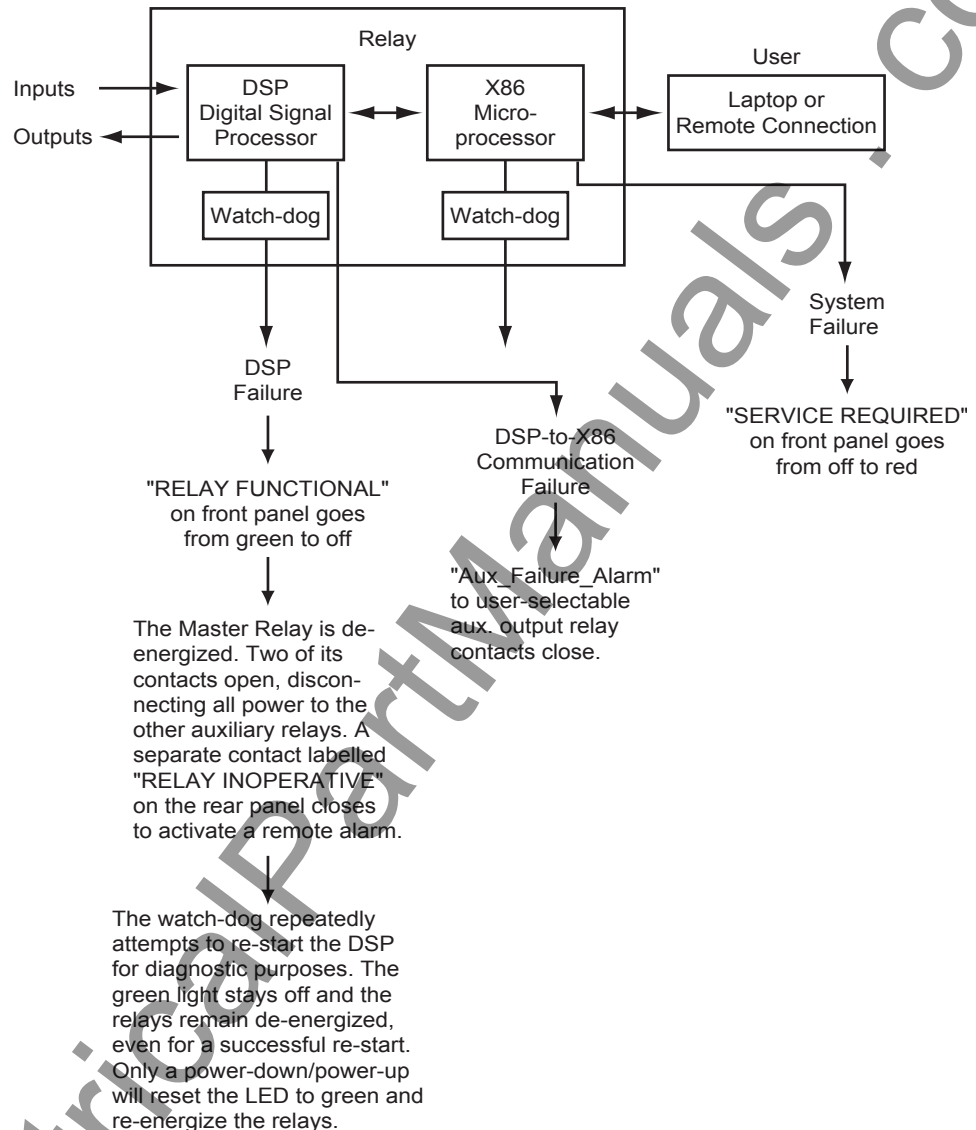

Note: For either of the above cases the DSP controller functions continue with normal auxiliary relay outputs provided that DSP failure or Self Check Fail: Block has not occurred.

Self Check Fail due to DC Offset Detector

The DSP has an algorithm that detects continuous dc levels on the analog inputs and initiates alarms and relay output contact blocking when the measured dc level exceeds the Alarm or Block level. The Alarm level is intended to provide an early indication of a problem. The Block level blocks the relay from false-tripping by preventing any output contact from closing. The Relay Functional LED turns off, but the protection functions will operate normally, with the exception that the output contacts will not be allowed to close. The Relay Inoperative contact will close for a Block condition. The following table describes all the Alarm/Block indication functions

Action	Condition	
	Alarm	Block
Relay Functional LED off		X
Service Required LED on	X	X
Self Check Fail Signal high	X	X
Relay Inoperative Contact closed		X
Output Contacts held open		X
Event Log Message	X	X
Status available through SCADA	X	X

The Self Check Fail signal, which is available in the Output Matrix, TUI metering and SCADA, can be used to signal an alarm. Note that if this signal is mapped to an output contact, the contact which it is mapped to will only be closed for an alarm condition. If the relay is in the Block condition, the Relay Inoperative contact must be used to signal an alarm.

The status of the Self Check Fail is available through the SCADA services provided by the B-PRO. The digital signal Self Check Fail will indicate that DSP has detected a continuous dc level and the analog metering value Self Check Fail Parameter is used to indicate which condition, Alarm or Block. The failure types and which analog values they are associated with are described in the table below. Both signals are available in DNP and Modbus.

Point Value	Condition
0	Normal
1	Alarm
2	Block
3	Alarm has evolved to block

The Alarm condition is allowed to reset if the continuous dc level drops below the pickup level. The Block condition has no reset level. If power is cycled to the relay it will go into its normal state until the continuous dc level is detected again.

Note: Self Check Fail appears as "Aux. Failure Alarm" in the settings versions before v2.

Appendix E Modbus RTU Communication Protocol

The SCADA port supports DNP3 and Modicon Modbus protocols. All metering values available through the terminal user interface are also available via the Modbus protocol. Additionally, the Modbus protocol support the reading of the unit time and time of the readings and provides access to trip and alarm events, include fault location information.

A “Hold Readings” function is available to freeze all metering readings into a snapshot (see Force Single Coil function, address 0).

Read Coil Status (Function Code 01)			
Channel	Address	Value	
Hold Readings	00001	0: Readings not held	1: Readings held
Reserved	00257	Reserved	Reserved
Output Contact 1	00513	0: Contact Open (inactive)	1: Contact Closed (active)
Output Contact 2	00514	0: Contact Open (inactive)	1: Contact Closed (active)
Output Contact 3	00515	0: Contact Open (inactive)	1: Contact Closed (active)
Output Contact 4	00516	0: Contact Open (inactive)	1: Contact Closed (active)
Output Contact 5	00517	0: Contact Open (inactive)	1: Contact Closed (active)
Output Contact 6	00518	0: Contact Open (inactive)	1: Contact Closed (active)
Output Contact 7	00519	0: Contact Open (inactive)	1: Contact Closed (active)
Output Contact 8	00520	0: Contact Open (inactive)	1: Contact Closed (active)
Output Contact 9	00521	0: Contact Open (inactive)	1: Contact Closed (active)
Output Contact 10	00522	0: Contact Open (inactive)	1: Contact Closed (active)
Output Contact 11	00523	0: Contact Open (inactive)	1: Contact Closed (active)
Output Contact 12	00524	0: Contact Open (inactive)	1: Contact Closed (active)
Output Contact 13	00525	0: Contact Open (inactive)	1: Contact Closed (active)
Output Contact 14	00526	0: Contact Open (inactive)	1: Contact Closed (active)
Input 1 5LS-1 Output	00769	0: Off (inactive)	1: On (active)
Input 1 50LS-2 Output	00770	0: Off (inactive)	1: On (active)
Input 1 50BF-1 Trip	00771	0: Off (inactive)	1: On (active)
Input 1 50BF-2 Trip	00772	0: Off (inactive)	1: On (active)
Input 1 50 Trip	00773	0: Off (inactive)	1: On (active)
Input 1 51 Alarm	00774	0: Off (inactive)	1: On (active)
Input 1 51 Trip	00775	0: Off (inactive)	1: On (active)
Input 1 50N Trip	00776	0: Off (inactive)	1: On (active)
Input 1 51N Alarm	00777	0: Off (inactive)	1: On (active)
Input 1 51N Trip	00778	0: Off (inactive)	1: On (active)

Read Coil Status (Function Code 01)			
Input 1 46-50 Trip	00779	0: Off (inactive)	1: On (active)
Input 1 46-51 Alarm	00780	0: Off (inactive)	1: On (active)
Input 1 46-51 Trip	00781	0: Off (inactive)	1: On (active)
Input 2 5LS-1 Output	00782	0: Off (inactive)	1: On (active)
Input 2 50LS-2 Output	00783	0: Off (inactive)	1: On (active)
Input 2 50BF-1 Trip	00784	0: Off (inactive)	1: On (active)
Input 2 50BF-2 Trip	00785	0: Off (inactive)	1: On (active)
Input 2 50 Trip	00786	0: Off (inactive)	1: On (active)
Input 2 51 Alarm	00787	0: Off (inactive)	1: On (active)
Input 2 51 Trip	00788	0: Off (inactive)	1: On (active)
Input 2 50N Trip	00789	0: Off (inactive)	1: On (active)
Input 2 51N Alarm	00790	0: Off (inactive)	1: On (active)
Input 2 51N Trip	00791	0: Off (inactive)	1: On (active)
Input 2 46-50 Trip	00792	0: Off (inactive)	1: On (active)
Input 2 46-51 Alarm	00793	0: Off (inactive)	1: On (active)
Input 2 46-51 Trip	00794	0: Off (inactive)	1: On (active)
Input 3 5LS-1 Output	00795	0: Off (inactive)	1: On (active)
Input 3 50LS-2 Output	00796	0: Off (inactive)	1: On (active)
Input 3 50BF-1 Trip	00797	0: Off (inactive)	1: On (active)
Input 3 50BF-2 Trip	00798	0: Off (inactive)	1: On (active)
Input 3 50 Trip	00799	0: Off (inactive)	1: On (active)
Input 3 51 Alarm	00800	0: Off (inactive)	1: On (active)
Input 3 51 Trip	00801	0: Off (inactive)	1: On (active)
Input 3 50N Trip	00802	0: Off (inactive)	1: On (active)
Input 3 51N Alarm	00803	0: Off (inactive)	1: On (active)
Input 3 51N Trip	00804	0: Off (inactive)	1: On (active)
Input 3 46-50 Trip	00805	0: Off (inactive)	1: On (active)
Input 3 46-51 Alarm	00806	0: Off (inactive)	1: On (active)
Input 3 46-51 Trip	00807	0: Off (inactive)	1: On (active)
Input 4 5LS-1 Output	00808	0: Off (inactive)	1: On (active)
Input 4 50LS-2 Output	00809	0: Off (inactive)	1: On (active)
Input 4 50BF-1 Trip	00810	0: Off (inactive)	1: On (active)
Input 4 50BF-2 Trip	00811	0: Off (inactive)	1: On (active)
Input 4 50 Trip	00812	0: Off (inactive)	1: On (active)
Input 4 51 Alarm	00813	0: Off (inactive)	1: On (active)
Input 4 51 Trip	00814	0: Off (inactive)	1: On (active)
Input 4 50N Trip	00815	0: Off (inactive)	1: On (active)
Input 4 51N Alarm	00816	0: Off (inactive)	1: On (active)
Input 4 51N Trip	00817	0: Off (inactive)	1: On (active)

Read Coil Status (Function Code 01)			
Input 4 46-50 Trip	00818	0: Off (inactive)	1: On (active)
Input 4 46-51 Alarm	00819	0: Off (inactive)	1: On (active)
Input 4 46-51 Trip	00820	0: Off (inactive)	1: On (active)
Input 5 5LS-1 Output	00821	0: Off (inactive)	1: On (active)
Input 5 50LS-2 Output	00822	0: Off (inactive)	1: On (active)
Input 5 50BF-1 Trip	00823	0: Off (inactive)	1: On (active)
Input 5 50BF-2 Trip	00824	0: Off (inactive)	1: On (active)
Input 5 50 Trip	00825	0: Off (inactive)	1: On (active)
Input 5 51 Alarm	00826	0: Off (inactive)	1: On (active)
Input 5 51 Trip	00827	0: Off (inactive)	1: On (active)
Input 5 50N Trip	00828	0: Off (inactive)	1: On (active)
Input 5 51N Alarm	00829	0: Off (inactive)	1: On (active)
Input 5 51N Trip	00830	0: Off (inactive)	1: On (active)
Input 5 46-50 Trip	00831	0: Off (inactive)	1: On (active)
Input 5 46-51 Alarm	00832	0: Off (inactive)	1: On (active)
Input 5 46-51 Trip	00833	0: Off (inactive)	1: On (active)
Input 6 5LS-1 Output	00834	0: Off (inactive)	1: On (active)
Input 6 50LS-2 Output	00835	0: Off (inactive)	1: On (active)
Input 6 50BF-1 Trip	00836	0: Off (inactive)	1: On (active)
Input 6 50BF-2 Trip	00837	0: Off (inactive)	1: On (active)
Input 6 50 Trip	00838	0: Off (inactive)	1: On (active)
Input 6 51 Alarm	00839	0: Off (inactive)	1: On (active)
Input 6 51 Trip	00840	0: Off (inactive)	1: On (active)
Input 6 50N Trip	00841	0: Off (inactive)	1: On (active)
Input 6 51N Alarm	00842	0: Off (inactive)	1: On (active)
Input 6 51N Trip	00843	0: Off (inactive)	1: On (active)
Input 6 46-50 Trip	00844	0: Off (inactive)	1: On (active)
Input 6 46-51 Alarm	00845	0: Off (inactive)	1: On (active)
Input 6 46-51 Trip	00846	0: Off (inactive)	1: On (active)
87T Trip	00847	0: Off (inactive)	1: On (active)
87B-1 Trip	00848	0: Off (inactive)	1: On (active)
59-1 Trip	00849	0: Off (inactive)	1: On (active)
59-2 Trip	00850	0: Off (inactive)	1: On (active)
27-1 Trip	00851	0: Off (inactive)	1: On (active)
27-2 Trip	00852	0: Off (inactive)	1: On (active)
60 Alarm	00853	0: Off (inactive)	1: On (active)
81O-1 Trip	00854	0: Off (inactive)	1: On (active)
81O-2 Trip	00855	0: Off (inactive)	1: On (active)
81U-1 Trip	00856	0: Off (inactive)	1: On (active)

Read Coil Status (Function Code 01)			
81U-2 Trip	00857	0: Off (inactive)	1: On (active)
Self Check Fail	00858	0: Off (inactive)	1: On (active)
ProLogic 1	00859	0: Off (inactive)	1: On (active)
ProLogic 2	00860	0: Off (inactive)	1: On (active)
ProLogic 3	00861	0: Off (inactive)	1: On (active)
ProLogic 4	00862	0: Off (inactive)	1: On (active)
ProLogic 5	00863	0: Off (inactive)	1: On (active)
ProLogic 6	00864	0: Off (inactive)	1: On (active)
ProLogic 7	00865	0: Off (inactive)	1: On (active)
ProLogic 8	00866	0: Off (inactive)	1: On (active)
ProLogic 9	00867	0: Off (inactive)	1: On (active)
ProLogic 10	00868	0: Off (inactive)	1: On (active)
ProLogic 11	00869	0: Off (inactive)	1: On (active)
ProLogic 12	00870	0: Off (inactive)	1: On (active)
ProLogic 13	00871	0: Off (inactive)	1: On (active)
ProLogic 14	00872	0: Off (inactive)	1: On (active)
ProLogic 15	00873	0: Off (inactive)	1: On (active)
87T Restraint	00874	0: Off (inactive)	1: On (active)
87T Fast Trip	00875	0: Off (inactive)	1: On (active)
87B-1 Fast Trip	00876	0: Off (inactive)	1: On (active)
87B-1 Block via Saturation	00877	0: Off (inactive)	1: On (active)
87B-2 Trip	00878	0: Off (inactive)	1: On (active)
87B-2 Fast Trip	00879	0: Off (inactive)	1: On (active)
87B-2 Block via Saturation	00880	0: Off (inactive)	1: On (active)

Read Input Status (Function Code 02)			
Channel	Address	Value	
External I/P 1	10001	0: Off (inactive)	1: On (active)
External I/P 2	10002	0: Off (inactive)	1: On (active)
External I/P 3	10003	0: Off (inactive)	1: On (active)
External I/P 4	10004	0: Off (inactive)	1: On (active)
External I/P 5	10005	0: Off (inactive)	1: On (active)
External I/P 6	10006	0: Off (inactive)	1: On (active)
External I/P 7	10007	0: Off (inactive)	1: On (active)
External I/P 8	10008	0: Off (inactive)	1: On (active)
External I/P 9	10009	0: Off (inactive)	1: On (active)
External Input 1 Change of state latch	10257	0: Off (inactive)	1: On (active)

External Input 2 Change of state latch	10258	0: Off (inactive)	1: On (active)
External Input 3 Change of state latch	10259	0: Off (inactive)	1: On (active)
External Input 4 Change of state latch	10260	0: Off (inactive)	1: On (active)
External Input 5 Change of state latch	10261	0: Off (inactive)	1: On (active)
External Input 6 Change of state latch	10262	0: Off (inactive)	1: On (active)
External Input 7 Change of state latch	10263	0: Off (inactive)	1: On (active)
External Input 8 Change of state latch	10264	0: Off (inactive)	1: On (active)
External Input 9 Change of state latch	10265	0: Off (inactive)	1: On (active)
Virtual Input #1	10513	0: Off (inactive)	1: On (active)
Virtual Input #2	10514	0: Off (inactive)	1: On (active)
Virtual Input #3	10515	0: Off (inactive)	1: On (active)
Virtual Input #4	10516	0: Off (inactive)	1: On (active)
Virtual Input #5	10517	0: Off (inactive)	1: On (active)
Virtual Input #6	10518	0: Off (inactive)	1: On (active)
Virtual Input #7	10519	0: Off (inactive)	1: On (active)
Virtual Input #8	10520	0: Off (inactive)	1: On (active)
Virtual Input #9	10521	0: Off (inactive)	1: On (active)
Virtual Input #10	10522	0: Off (inactive)	1: On (active)
Virtual Input #11	10523	0: Off (inactive)	1: On (active)
Virtual Input #12	10524	0: Off (inactive)	1: On (active)
Virtual Input #13	10525	0: Off (inactive)	1: On (active)
Virtual Input #14	10526	0: Off (inactive)	1: On (active)
Virtual Input #15	10527	0: Off (inactive)	1: On (active)
Virtual Input #16	10528	0: Off (inactive)	1: On (active)
Virtual Input #17	10529	0: Off (inactive)	1: On (active)
Virtual Input #18	10530	0: Off (inactive)	1: On (active)
Virtual Input #19	10531	0: Off (inactive)	1: On (active)

Read Holding Registers (Function Code 03)			
Channel	Address	Units	Scale
B-PRO Clock Time (UTC). Read all in same query to ensure consistent time reading data			
Milliseconds Now	40001	0-999	1
Seconds Now	40002	0-59	1
Minutes Now	40003	0-59	1
Hours Now	40004	0-23	1
Day of Year Now	40005	1-365 (up to 366 if leap year)	1
Years since 1900	40006	90-137	1
Sync'd to IRIG-B	40007	0: No 1: Yes	1
Time of Acquisition (UTC). Read all in same query to ensure consistent time reading data			
Milliseconds Now	40008	0-999	1
Seconds Now	40009	0-59	1
Minutes Now	40010	0-59	1
Hours Now	40011	0-23	1
Day of Year Now	40012	1-365 (up to 366 if leap year)	1
Years since 1900	40013	90-137	1
Sync'd to IRIG-B	40014	0: No 1: Yes	1
Offset of UTC to IED local time.	40015	2's complement half hours, North America is negative	1
VA Magnitude	40257	KV	10
VA Angle	40258	Degrees	10
VB Magnitude	40259	KV	10
VB Angle	40260	Degrees	10
VC Magnitude	40261	KV	10
VC Angle	40262	Degrees	10
I1A Magnitude	40263	A	1
I1A Angle	40264	Degrees	10
I1B Magnitude	40265	A	1
I1B Angle	40266	Degrees	10
I1C Magnitude	40267	A	1
I1C Angle	40268	Degrees	10
I2A Magnitude	40269	A	1
I2A Angle	40270	Degrees	10
I2B Magnitude	40271	A	1
I2B Angle	40272	Degrees	10
I2C Magnitude	40273	A	1
I2C Angle	40274	Degrees	10
I3A Magnitude	40275	A	1

Read Holding Registers (Function Code 03)			
I3A Angle	40276	Degrees	10
I3B Magnitude	40277	A	1
I3B Angle	40278	Degrees	10
I3C Magnitude	40279	A	1
I3C Angle	40280	Degrees	10
I4A Magnitude	40281	A	1
I4A Angle	40282	Degrees	10
I4B Magnitude	40283	A	1
I4B Angle	40284	Degrees	10
I4C Magnitude	40285	A	1
I4C Angle	40286	Degrees	10
I5A Magnitude	40287	A	1
I5A Angle	40288	Degrees	10
I5B Magnitude	40289	A	1
I5B Angle	40290	Degrees	10
I5C Magnitude	40291	A	1
I5C Angle	40292	Degrees	10
I6A Magnitude	40293	A	1
I6A Angle	40294	Degrees	10
I6B Magnitude	40295	A	1
I6B Angle	40296	Degrees	10
I6C Magnitude	40297	A	1
I6C Angle	40298	Degrees	10
Transformer IA Operating	40299	A	1
Transformer IB Operating	40300	A	1
Transformer IC Operating	40301	A	1
Transformer IA Restraint	40302	A	1
Transformer IB Restraint	40303	A	1
Transformer IC Restraint	40304	A	1
Bus IA Operating	40305	A	1
Bus IB Operating	40306	A	1
Bus IC Operating	40307	A	1
Bus IA Restraint	40308	A	1
Bus IB Restraint	40309	A	1
Bus IC Restraint	40310	A	1
Input 1 P	40311	MW	10
Input 1 Q	40312	MVARS	10
Input 2 P	40313	MW	10
Input 2 Q	40314	MVARS	10

Read Holding Registers (Function Code 03)			
Input 3 P	40315	MW	10
Input 3 Q	40316	MVARS	10
Input 4 P	40317	MW	10
Input 4 Q	40318	MVARS	10
Input 5 P	40319	MW	10
Input 5 Q	40320	MVARS	10
Input 6 P	40321	MW	10
Input 6 Q	40322	MVARS	10
Positive Sequence V	40323	kV	10
Frequency	40324	Hz	100
87B-2 IA Operating	40325	A	1
87B-2 IB Operating	40326	A	1
87B-2 IC Operating	40327	A	1
87B-2 IA Restraint	40328	A	1
87B-2 IB Restraint	40329	A	1
87B-2 IC Restraint	40330	A	1
Self Check Fail Parameter	40331	N/A	1

Read Input Register (Function Code 04)
No input registers supported. Response from IED indicates "ILLEGAL FUNCTION."

Force Single Coil (Function Code 05)			
Only the "hold readings" coil can be forced. When active, this coil locks all coil, input and holding register readings simultaneously at their present values. When inactive, coil, input and holding register values will read their most recently available state.			
Channel	Type	Address	Value
Hold Readings	Read/Write	01	0000: Readings update normally (inactive) FF00: Hold readings (active)

Preset Single Register (Function Code 06)			
Channel	Address	Value	Scaled Up By
Event Message Control (See below for details of use)			
Refresh event list	40513	No data required	N/A
Acknowledge the current event and get the next event	40514	No data required	N/A

Get the next event (without acknowledge)	40515	No data required	N/A
--	-------	------------------	-----

Diagnostic Subfunctions (Function Code 08)	
Return Query Data (Subfunction 00)	This provides an echo of the submitted message.
Restart Comm. Option (Subfunction 01)	This restarts the Modbus communications process.
Force Listen Only Mode (Subfunction 04)	No response is returned. IED enters "Listen Only" mode. This mode can only be exited by the "Restart Comm. Option" command.

Report Slave ID (Function Code 17/0x11)			
A fixed response is returned by the IED, including system model, version and issue numbers.			
Channel	Type	Bytes	Value
Model Number	Read Only	0 and 1	21FC = 8700 decimal
Version Number	Read Only	2 and 3	Version number
Issue Number	Read Only	4 and 5	Issue number

- The B-PRO IED model number is 8700/BUS.
- Version and issue will each be positive integers, say X and Y.
- The B-PRO is defined as “Model 8700/BUS, Version X Issue Y”

Accessing B-PRO Event Information	
All B-PRO detector event messages displayed in the Event Log are available via Modbus. This includes fault location information. The following controls are available.	
Refresh Event List	(Function Code 6, address 40513): Fetches the latest events from the B-PRO's event log and makes them available for Modbus access. The most recent event becomes the current event available for reading.
Acknowledge Current Event and Get Next Event	(Function Code 6, address 40514): Clears the current event from the read registers and places the next event into them. An acknowledged event is no longer available for reading.
Get Next Event	(Function Code 6, address 40515): Places the next event in the read registers without acknowledging the current event. The current event will reappear in the list when Refresh Event List is used.
Size of Current Event Message	(Function Code 3, address 40516): Indicates the number of 16 bit registers used to contain the current event. Event data is stored with two characters per register. A reading of zero indicates that there are no unacknowledged events available in the current set. (NB. The Refresh Event List function can be used to check for new events that have occurred since the last Refresh Event List.)
Read Event Message	(Function Code 3, addresses 40517 - 40576): Contains the current event message. Two ASCII characters are packed into each 16 bit register. All unused registers in the set are set to 0.

Modbus Event Message Example

"2002May15 16:45:07.848: 27-1 (U/V) on ABC: Trip"

Register	Value		Meaning
	High Byte	Low Byte	
40516	0x00	0x19	Event text size = 25 (0x19 hex)
40517	0x20	0x20	'<sp>', '<sp>'
40518	0x32	0x30	'2', '0'
40519	0x30	0x32	'0', '2'
40520	0x40	0x61	'M', 'a'
40521	0x79	0x31	'y', '1'
40522	0x35	0x20	'5', '<sp>'
40523	0x31	0x36	'1', '6'
40524	0x3A	0x34	':', '4'
40525	0x35	0x3A	'5', ':'
40526	0x30	0x37	'0', '7'
40527	0x2E	0x38	':', '8'
40528	0x34	0x38	'4', '8'
40529	0x20	0x3A	'<sp>', ':'
40530	0x20	0x32	'<sp>', '2'
40531	0x37	0x2D	'7', '-'
40532	0x31	0x20	'1', '<sp>'
40533	0x28	0x55	'(', 'U'
40534	0x2F	0x56	',' , 'V'
40535	0x29	0x20	'),' , '<sp>'
40536	0x6F	0x6E	'o', 'n'
40537	0x20	0x41	'<sp>', 'A'
40538	0x42	0x43	'B', 'C'
40539	0x3A	0x20	':', '<sp>'
40540	0x54	0x72	'T', 'r'
40541	0x69	0x70	'i', 'p'

Appendix F DNP3 Communication Protocol

Device Profile

The DNP3 SCADA protocol is available through a direct serial link (Port 3) or the Ethernet LAN over the TCP or UDP protocols (network card required). All metering values available through the terminal user interface are available by DNP3 protocol. Included are the device profile, implementation table and the point list for the DNP3 protocol.

Vendor Name: ERLPhase Corporation	Device Name: Relay Model #
Highest DNP Level Supported: For Requests: 2 For Responses: 2	Device Function: _ Master x Slave
Maximum Data Link Frame Size (octets): Transmitted: 292 Received: 292	Maximum Application Frame Size (octets): Transmitted: 2048 Received: 2048
Maximum Data Link Re-tries: _ None x Fixed at 3 _ Configurable, range __ to __	Maximum Application Layer Re-tries: x None _ Configurable, range __ to __
Requires Data Link Layer Confirmation: _ Never _ Always _ Sometimes x Configurable, either always or never	Requires Application Layer Confirmation: _ Never _ Always (not recommended) x When reporting Event Data (Slave) x When sending multi-fragment responses (Slave) _ Sometimes _ Configurable
Timeouts (in seconds) while waiting for:	
Data Link Confirm __None	x Fixed at 2
Complete Application Fragment x None	__Fixed at 2
Application Confirm __None	x Fixed at 5
Complete Application Response x None	__Fixed at 2
Others	
Select to execute delay __None	x Fixed at 10
Sends/Executes Control Operations:	
WRITE Binary Outputs x Never	__Always
SELECT/OPERATE __Never	x Always
DIRECT OPERATE __Never	x Always
DIRECT OPERATE No ACK __Never	x Always
Count > 1 x Never	__Always
Pulse On __Never	x Always
Pulse Off x Never	__Always
Latch On __Never	x Always
Latch Off __Never	x Always
Queue x Never	__Always
Clear Queue x Never	__Always
Maximum number of control objects per request: 16	
Notes:	
Control Trip/Close - Code Combination supported:	
Latch On/NUL	
Latch Off/NUL	
Pulse On/NUL (Pulse duration fixed at 1 s)	
Report Binary Input Change Events when no specific variation requested: __Never __Only time-tagged x Only non-time-tagged _ Configurable to send both, one or the other	Reports time-tagged Binary Input Change Events when no specific variation requested __Never x Binary Input Change with Time _ Binary Input Change with Relative Time _ Configurable
Sends Unsolicited Response: x Never _ Configurable	Sends Static Data in Unsolicited Responses: x Never _ When Device Restarts

_ Only certain objects _ Sometimes _ ENABLE/DISABLE UNSOLICITED Function codes supported	_ When Status Flags Change No other options are permitted.
Default Counter Object/Variation: x No Counter Reported _ Configurable _ Default Object _____ _ Default Variation _____ _ Point-by-point list attached	Counters Roll Over at: x No Counters Reported _ Configurable _ 16 Bits _ 32 Bits _ Other Value _____ _ Point-by-point list attached

Implementation Table

Object			Request		Response	
Grp	Var	Description	Function Code	Qualifier Codes (hex)	Function Code	Qualifier Codes (hex)
1	0	Binary Input - All Variations	1 (read)	0x00, 0x01, 0x06, 0x07, 0x08, 0x17, 0x28	129 (response)	0x00
1	1	Binary Input (default)	1 (read)	0x00, 0x01, 0x06, 0x07, 0x08, 0x17, 0x28	129 (response)	0x00
1	2	Binary Input with Status	1 (read)	0x00, 0x01, 0x06, 0x07, 0x08, 0x17, 0x28	129 (response)	0x00
2	0	Binary Input Change - All Variations	1 (read)	0x06, 0x07, 0x08	129 (response)	0x17
2	1	Binary Input Change without Time	1 (read)	0x06, 0x07, 0x08	129 (response)	0x17
2	2	Binary Input Change with Time (default)	1 (read)	0x06, 0x07, 0x08	129 (response)	0x17
2	3	Binary Input Change with Relative Time	1 (read)	0x06, 0x07, 0x08	129 (response)	0x17
10	0	Binary Output - All Variations	1 (read)	0x00, 0x01, 0x06, 0x07, 0x08, 0x17, 0x28	129 (response)	0x00
10	2	Binary Output Status (default)	1 (read)	0x00, 0x01, 0x06, 0x07, 0x08, 0x17, 0x28	129 (response)	0x00
12	1	Control Relay Output Block	3 (select), 4 (operate), 5 (direct op) 6 (direct op, no ack)	0x00, 0x01, 0x07, 0x08, 0x17, 0x18	129 (response)	echo of request
30	0	Analog Input - All Variations	1 (read)	0x00, 0x01, 0x06, 0x07, 0x08, 0x17, 0x28	129 (response)	0x01
30	1	32-bit Analog Input	1 (read)	0x00, 0x01, 0x06, 0x07, 0x08, 0x17, 0x28	129 (response)	0x01
30	2	16-bit Analog Input	1 (read)	0x00, 0x01, 0x06, 0x07, 0x08, 0x17, 0x28	129 (response)	0x01
30	3	32-bit Analog Input without flag	1 (read)	0x00, 0x01, 0x06, 0x07, 0x08, 0x17, 0x28	129 (response)	0x01
30	4	16-bit Analog Input without flag (default)	1 (read)	0x00, 0x01, 0x06, 0x07, 0x08, 0x17, 0x28	129 (response)	0x01
32	0	Analog Input Change Event - All Variations	1 (read)	0x06, 0x07, 0x08	129 (response)	0x28
32	1	Analog Input Change Event - 32-bit without Time	1 (read)	0x06, 0x07, 0x08	129 (response)	0x28
32	2	Analog Input Change Event - 16-bit without Time (default)	1 (read)	0x06, 0x07, 0x08	129 (response)	0x28
32	3	Analog Input Change Event - 32-bit with Time	1 (read)	0x06, 0x07, 0x08	129 (response)	0x28
32	4	Analog Input Change Event - 16-bit with Time	1 (read)	0x06, 0x07, 0x08	129 (response)	0x28
51	1	Time and Data CTO			129 (response)	0x07, quantity=1

52	1	Time Delay Coarse			129 (response)	0x07, quantity=1
60	1	Class 0 Data	1 (read)	0x06		
60	2	Class 1 Data	1 (read)	0x06, 0x07, 0x08		
60	3	Class 2 Data	1 (read)	0x06, 0x07, 0x08		
80	1	Internal Indications	2 (write)	0x00, index=7		
110	0	Octet String	1 (read)	0x06	129 (response)	0x07
111	0	Octet String Change Event	1 (read)	0x06	129 (response)	0x07
		No Object	14 (warm restart)			

Point List

Binary Inputs (Obj 1, 2)	Static Points	Change Event Points
Object Group	1	2
Object Variation	1 – Binary Input (default) 2 – Binary Input with Status	1 – Binary Input Change without Time 1 – Binary Input Change with Time (default) 3 – Binary Input Change with Relative Time
Class	0	1
Note: Binary inputs are scanned with 1 ms resolution.		
Change Event Buffer Size		100

Binary Inputs	Point Index	Change Event Class
External Input 1	0	1
External Input 2	1	1
External Input 3	2	1
External Input 4	3	1
External Input 5	4	1
External Input 6	5	1
External Input 7	6	1
External Input 8	7	1
External Input 9	8	1
Virtual Input #1	9	1
Virtual Input #2	10	1
Virtual Input #3	11	1
Virtual Input #4	12	1
Virtual Input #5	13	1
Virtual Input #6	14	1
Virtual Input #7	15	1

Virtual Input #8	16	1
Virtual Input #9	17	1
Virtual Input #10	18	1
Virtual Input #11	19	1
Virtual Input #12	20	1
Virtual Input #13	21	1
Virtual Input #14	22	1
Virtual Input #15	23	1
Virtual Input #16	24	1
Virtual Input #17	25	1
Virtual Input #18	26	1
Virtual Input #19	27	1
Virtual Input #20	28	1
Virtual Input #21	29	1
Virtual Input #22	30	1
Virtual Input #23	31	1
Virtual Input #24	32	1
Virtual Input #25	33	1
Virtual Input #26	34	1
Virtual Input #27	35	1
Virtual Input #28	36	1
Virtual Input #29	37	1
Virtual Input #30	38	1

Binary Outputs (Obj 10)		
	Static Points	Change Event Points
Object Group	10	Not Applicable
Object Variation	2 – Binary Output Status (default)	Not Applicable
Class	0	Not Applicable
Note: Binary outputs are scanned with 500 ms resolution.		
No change buffer		

Binary Outputs	Point Index	Change Event Class	Object Group
Output Contact 1	0	N/A	10
Output Contact 2	1	N/A	10
Output Contact 3	2	N/A	10
Output Contact 4	3	N/A	10
Output Contact 5	4	N/A	10
Output Contact 6	5	N/A	10
Output Contact 7	6	N/A	10
Output Contact 8	7	N/A	10
Output Contact 9	8	N/A	10
Output Contact 10	9	N/A	10
Output Contact 11	10	N/A	10
Output Contact 12	11	N/A	10
Output Contact 13	12	N/A	10
Output Contact 14	13	N/A	10
Input 1 5LS-1 Output	14	N/A	10
Input 1 50LS-2 Output	15	N/A	10
Input 1 50BF 1 Trip	16	N/A	10
Input 1 50BF-2 Trip	17	N/A	10
Input 1 50 Trip	18	N/A	10
Input 1 51 Alarm	19	N/A	10
Input 1 51 Trip	20	N/A	10
Input 1 50N Trip	21	N/A	10
Input 1 51N Alarm	22	N/A	10
Input 1 51N Trip	23	N/A	10
Input 1 46-50 Trip	24	N/A	10
Input 1 46-51 Alarm	25	N/A	10
Input 1 46-51 Trip	26	N/A	10
Input 2 5LS-1 Output	27	N/A	10
Input 2 50LS-2 Output	28	N/A	10
Input 2 50BF-1 Trip	29	N/A	10
Input 2 50BF-2 Trip	30	N/A	10
Input 2 50 Trip	31	N/A	10
Input 2 51 Alarm	32	N/A	10
Input 2 51 Trip	33	N/A	10
Input 2 50N Trip	34	N/A	10
Input 2 51N Alarm	35	N/A	10
Input 2 51N Trip	36	N/A	10

Binary Outputs	Point Index	Change Event Class	Object Group
Input 2 46-50 Trip	37	N/A	10
Input 2 46-51 Alarm	38	N/A	10
Input 2 46-51 Trip	39	N/A	10
Input 3 5LS-1 Output	40	N/A	10
Input 3 50LS-2 Output	41	N/A	10
Input 3 50BF-1 Trip	42	N/A	10
Input 3 50BF-2 Trip	43	N/A	10
Input 3 50 Trip	44	N/A	10
Input 3 51 Alarm	45	N/A	10
Input 3 51 Trip	46	N/A	10
Input 3 50N Trip	47	N/A	10
Input 3 51N Alarm	48	N/A	10
Input 3 51N Trip	49	N/A	10
Input 3 46-50 Trip	50	N/A	10
Input 3 46-51 Alarm	51	N/A	10
Input 3 46-51 Trip	52	N/A	10
Input 4 5LS-1 Output	53	N/A	10
Input 4 50LS-2 Output	54	N/A	10
Input 4 50BF-1 Trip	55	N/A	10
Input 4 50BF-2 Trip	56	N/A	10
Input 4 50 Trip	57	N/A	10
Input 4 51 Alarm	58	N/A	10
Input 4 51 Trip	59	N/A	10
Input 4 50N Trip	60	N/A	10
Input 4 51N Alarm	61	N/A	10
Input 4 51N Trip	62	N/A	10
Input 4 46-50 Trip	63	N/A	10
Input 4 46-51 Alarm	64	N/A	10
Input 4 46-51 Trip	65	N/A	10
Input 5 5LS-1 Output	66	N/A	10
Input 5 50LS-2 Output	67	N/A	10
Input 5 50BF-1 Trip	68	N/A	10
Input 5 50BF-2 Trip	69	N/A	10
Input 5 50 Trip	70	N/A	10
Input 5 51 Alarm	71	N/A	10
Input 5 51 Trip	72	N/A	10
Input 5 50N Trip	73	N/A	10
Input 5 51N Alarm	74	N/A	10
Input 5 51N Trip	75	N/A	10

Binary Outputs	Point Index	Change Event Class	Object Group
Input 5 46-50 Trip	76	N/A	10
Input 5 46-51 Alarm	77	N/A	10
Input 5 46-51 Trip	78	N/A	10
Input 6 5LS-1 Output	79	N/A	10
Input 6 50LS-2 Output	80	N/A	10
Input 6 50BF-1 Trip	81	N/A	10
Input 6 50BF-2 Trip	82	N/A	10
Input 6 50 Trip	83	N/A	10
Input 6 51 Alarm	84	N/A	10
Input 6 51 Trip	85	N/A	10
Input 6 50N Trip	86	N/A	10
Input 6 51N Alarm	87	N/A	10
Input 6 51N Trip	88	N/A	10
Input 6 46-50 Trip	89	N/A	10
Input 6 46-51 Alarm	90	N/A	10
Input 6 46-51 Trip	91	N/A	10
87T Trip	92	N/A	10
87B Trip	93	N/A	10
59 1 Trip	94	N/A	10
59 2 Trip	95	N/A	10
27 1 Trip	96	N/A	10
27 2 Trip	97	N/A	10
60 Alarm	98	N/A	10
81O 1 Trip	99	N/A	10
81O 2 Trip	100	N/A	10
81U 1 Trip	101	N/A	10
81U 2 Trip	102	N/A	10
Self Check Fail	103	N/A	10
ProLogic 1	104	N/A	10
ProLogic 2	105	N/A	10
ProLogic 3	106	N/A	10
ProLogic 4	107	N/A	10
ProLogic 5	108	N/A	10
ProLogic 6	109	N/A	10
ProLogic 7	110	N/A	10
ProLogic 8	111	N/A	10
ProLogic 9	112	N/A	10
ProLogic 10	113	N/A	10
ProLogic 11	114	N/A	10

Binary Outputs	Point Index	Change Event Class	Object Group
ProLogic 12	115	N/A	10
ProLogic 13	116	N/A	10
ProLogic 14	117	N/A	10
ProLogic 15	118	N/A	10
87T Restraint	119	N/A	10
87T Fast Trip	120	N/A	10
87B-1 Fast Trip	121	N/A	10
87B-1 Block via Saturation	122	N/A	10
87B-2 Trip	123	N/A	10
87B-2 Fast Trip	124	N/A	10
87B-2 Block via Saturation	125	N/A	10
Virtual Input #1	126	N/A	10, 12
Virtual Input #2	127	N/A	10, 12
Virtual Input #3	128	N/A	10, 12
Virtual Input #4	129	N/A	10, 12
Virtual Input #5	130	N/A	10, 12
Virtual Input #6	131	N/A	10, 12
Virtual Input #7	132	N/A	10, 12
Virtual Input #8	133	N/A	10, 12
Virtual Input #9	134	N/A	10, 12
Virtual Input #10	135	N/A	10, 12
Virtual Input #11	136	N/A	10, 12
Virtual Input #12	137	N/A	10, 12
Virtual Input #13	138	N/A	10, 12
Virtual Input #14	139	N/A	10, 12
Virtual Input #15	140	N/A	10, 12
Virtual Input #16	141	N/A	10, 12
Virtual Input #17	142	N/A	10, 12
Virtual Input #18	143	N/A	10, 12
Virtual Input #19	144	N/A	10, 12
Virtual Input #20	145	N/A	10, 12
Virtual Input #21	146	N/A	10, 12
Virtual Input #22	147	N/A	10, 12
Virtual Input #23	148	N/A	10, 12
Virtual Input #24	149	N/A	10, 12
Virtual Input #25	150	N/A	10, 12
Virtual Input #26	151	N/A	10, 12
Virtual Input #27	152	N/A	10, 12
Virtual Input #28	153	N/A	10, 12

Binary Outputs	Point Index	Change Event Class	Object Group
Virtual Input #29	154	N/A	10, 12
Virtual Input #30	155	N/A	10, 12

Analog Inputs (Obj 30, 31)		
	Static Points	Change Event Points
Object Group	30	32
Object Variation	1 - 32-bit Analog Input	1 - Analog Input Change - 32-bit without Time
	2 - 16-bit Analog Input	2 - Analog Input Change - 16-bit without Time (default)
	3 - 32-bit Analog Input without flag	3 - Analog Input Change - 32-bit with Time
	4 - 16-bit Analog Input without flag (default)	4 - Analog Input Change - 16-bit with Time
Class	0	2
Note: Analog Inputs are scanned with 500 ms resolution. Note: Nominal is based on 69 V secondary voltage * PT ratio for voltage channels, and either 1A or 5A secondary current * CT ratio for current channels dependent upon the format of CT installed in the B-PRO.		

Analog Inputs	Point Index	Units	Scale	Change Event Class	Deadband
VA Magnitude	0	kV	10	2	2% Nominal
VA Angle	1	Degrees	10	2	0.5 Degrees
VB Magnitude	2	kV	10	2	2% Nominal
VB Angle	3	Degrees	10	2	0.5 Degrees
VC Magnitude	4	kV	10	2	2% Nominal
VC Angle	5	Degrees	10	2	0.5 Degrees
I1A Magnitude	6	A	1	2	2% Nominal
I1A Angle	7	Degrees	10	2	0.5 Degrees
I1B Magnitude	8	A	1	2	2% Nominal
I1B Angle	9	Degrees	10	2	0.5 Degrees
I1C Magnitude	10	A	1	2	2% Nominal
I1C Angle	11	Degrees	10	2	0.5 Degrees
I2A Magnitude	12	A	1	2	2% Nominal
I2A Angle	13	Degrees	10	2	0.5 Degrees
I2B Magnitude	14	A	1	2	2% Nominal
I2B Angle	15	Degrees	10	2	0.5 Degrees
I2C Magnitude	16	A	1	2	2% Nominal
I2C Angle	17	Degrees	10	2	0.5 Degrees
I3A Magnitude	18	A	1	2	2% Nominal
I3A Angle	19	Degrees	10	2	0.5 Degrees
I3B Magnitude	20	A	1	2	2% Nominal
I3B Angle	21	Degrees	10	2	0.5 Degrees
I3C Magnitude	22	A	1	2	2% Nominal
I3C Angle	23	Degrees	10	2	0.5 Degrees
I4A Magnitude	24	A	1	2	2% Nominal
I4A Angle	25	Degrees	10	2	0.5 Degrees
I4B Magnitude	26	A	1	2	2% Nominal
I4B Angle	27	Degrees	10	2	0.5 Degrees
I4C Magnitude	28	A	1	2	2% Nominal
I4C Angle	29	Degrees	10	2	0.5 Degrees
I5A Magnitude	30	A	1	2	2% Nominal
I5A Angle	31	Degrees	10	2	0.5 Degrees
I5B Magnitude	32	A	1	2	2% Nominal
I5B Angle	33	Degrees	10	2	0.5 Degrees
I5C Magnitude	34	A	1	2	2% Nominal
I5C Angle	35	Degrees	10	2	0.5 Degrees
I6A Magnitude	36	A	1	2	2% Nominal

Analog Inputs	Point Index	Units	Scale	Change Event Class	Deadband
I6A Angle	37	Degrees	10	2	0.5 Degrees
I6B Magnitude	38	A	1	2	2% Nominal
I6B Angle	39	Degrees	10	2	0.5 Degrees
I6C Magnitude	40	A	1	2	2% Nominal
I6C Angle	41	Degrees	10	2	0.5 Degrees
Transformer IA Operating	42	A	1	2	2% Nominal
Transformer IB Operating	43	A	1	2	2% Nominal
Transformer IC Operating	44	A	1	2	2% Nominal
Transformer IA Restraint	45	A	1	2	2% Nominal
Transformer IB Restraint	46	A	1	2	2% Nominal
Transformer IC Restraint	47	A	1	2	2% Nominal
Bus IA Operating	48	A	1	2	2% Nominal
Bus IB Operating	49	A	1	2	2% Nominal
Bus IC Operating	50	A	1	2	2% Nominal
Bus IA Restraint	51	A	1	2	2% Nominal
Bus IB Restraint	52	A	1	2	2% Nominal
Bus IC Restraint	53	A	1	2	2% Nominal
Input 1 P	54	MW	10	2	1.0 MW
Input 1 Q	55	MVAR	10	2	0.5 MVAR
Input 2 P	56	MW	10	2	1.0 MW
Input 2 Q	57	MVAR	10	2	0.5 MVAR
Input 3 P	58	MW	10	2	1.0 MW
Input 3 Q	59	MVAR	10	2	0.5 MVAR
Input 4 P	60	MW	10	2	1.0 MW
Input 4 Q	61	MVAR	10	2	0.5 MVAR
Input 5 P	62	MW	10	2	1.0 MW
Input 5 Q	63	MVAR	10	2	0.5 MVAR
Input 6 P	64	MW	10	2	1.0 MW
Input 6 Q	65	MVAR	10	2	0.5 MVAR
Positive Sequence V	66	KV	10	2	2% Nominal
Frequency	67	Hz	100	2	0.05 Hz
87B-2 IA Operating	68	A	1	2	2% Nominal
87B-2 IB Operating	69	A	1	2	2% Nominal
87B-2 IC Operating	70	A	1	2	2% Nominal
87B-2 IA Restraint	71	A	1	2	2% Nominal
87B-2 IB Restraint	72	A	1	2	2% Nominal
87B-2 IC Restraint	73	A	1	2	2% Nominal
Self Check Fail Parameter	74	N/A	1	2	0.5

Object 110, 111 - Octet String for Event Log access

Object 110 and Object 111 are Octet String objects used to provide access to the Event Log text of the B-PRO. These objects are described in Technical Bulletin 9701-004.zip_71 available from the DNP user group web page (www.dnp.org). Object 110 always contains the most recent event in the B-PRO. Object 111 is the corresponding change event object. As stated in the DNP technical bulletin, the variation of the response object represents the length of the string. The string represents the ASCII values of the event text. The following example shows an event returned through either of the octet string objects.

DNP Example: Event Message

“ 1999Dec08 07:27:55.248 : 27-2 (U/V) on ABC: Trip”

DNP Octet string object contents:				
0x20	0x20	0x31	0x39	0x39
0x39	0x44	0x65	0x63	0x30
0x38	0x20	0x30	0x37	0x3A
0x32	0x37	0x3A	0x35	0x35
0x2E	0x32	0x34	0x38	0x20
0x3A	0x20	0x32	0x37	0x2D
0x32	0x20	0x28	0x55	0x2F
0x56	0x29	0x20	0x6F	0x6E
0x20	0x41	0x42	0x43	0x3A
0x20	0x54	0x72	0x69	0x70

Appendix G Mechanical Drawings

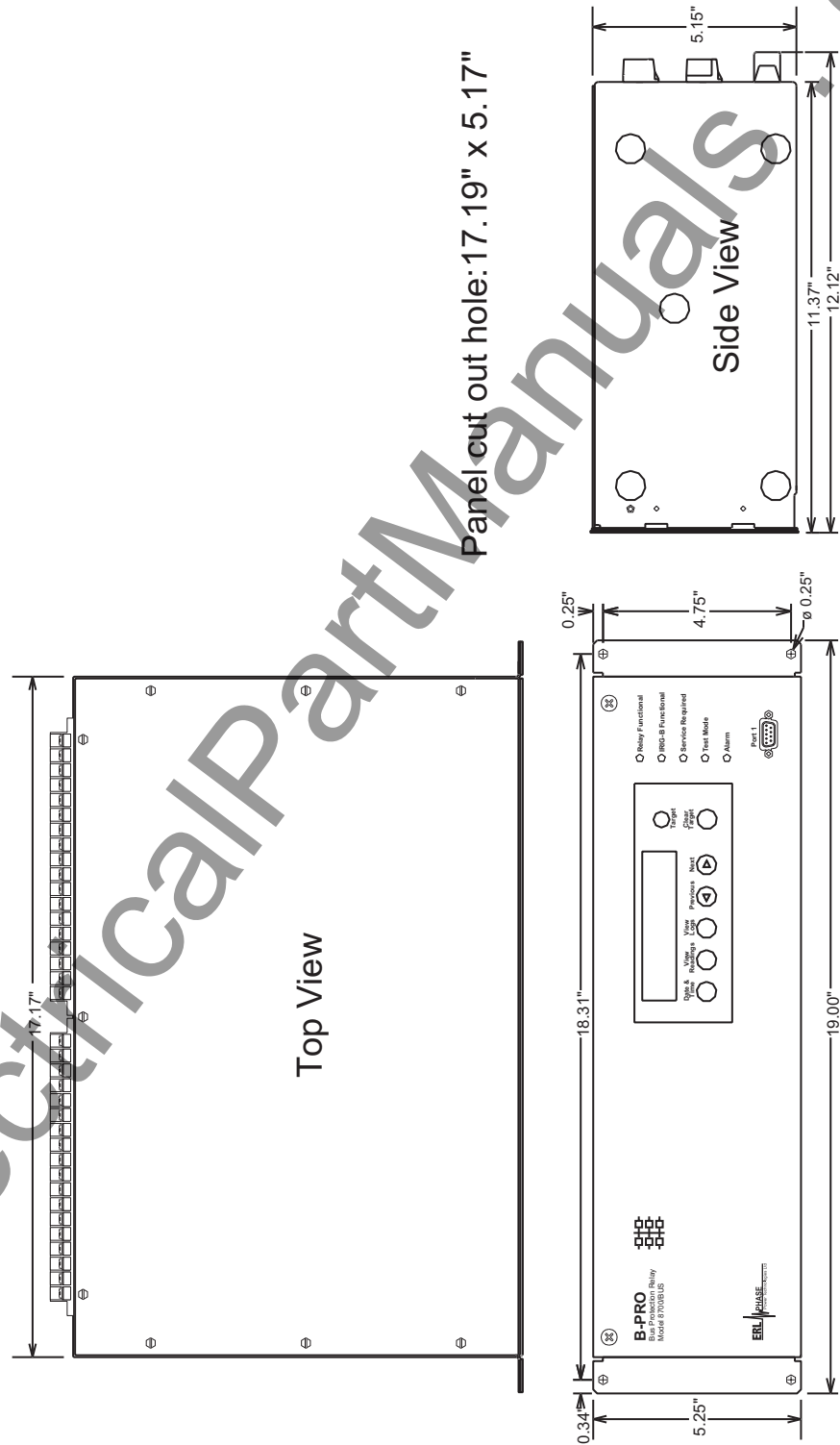

Figure G.1: Mechanical Drawing

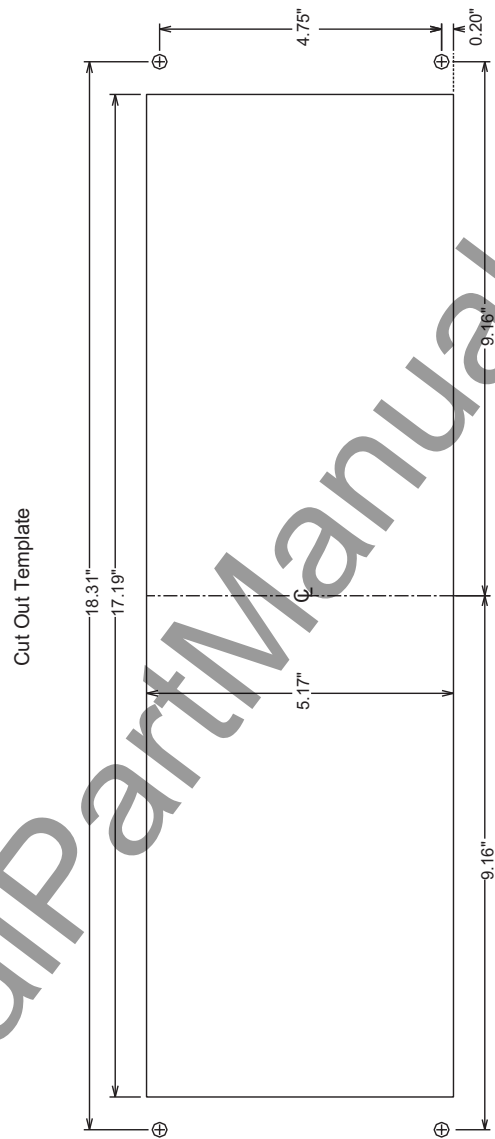

Figure G.2: Cut-out Template

Appendix H Rear Panel Drawings

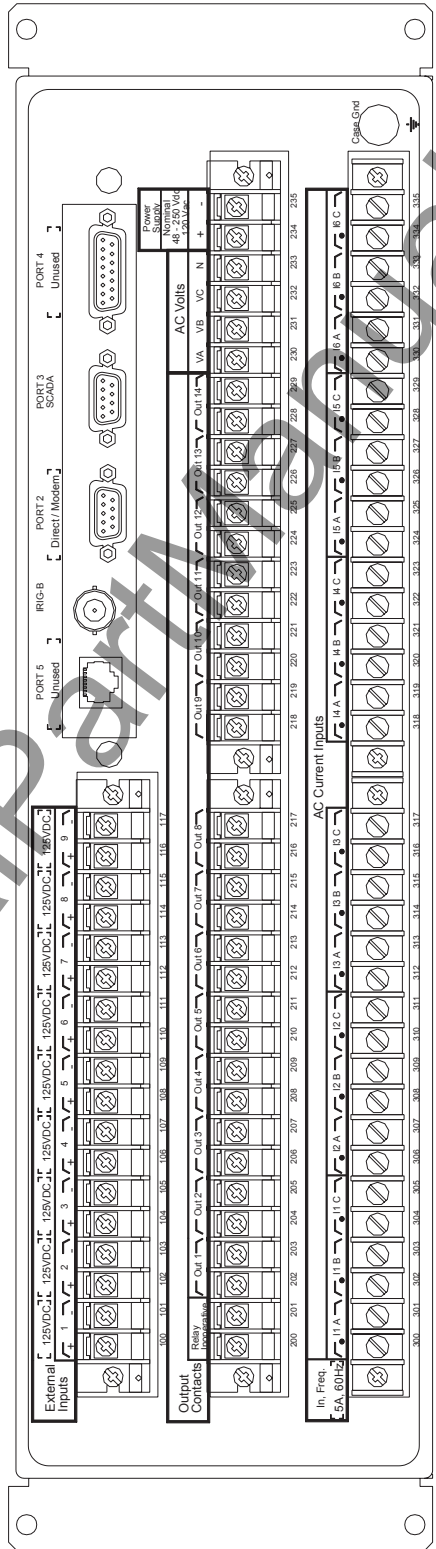

Figure H.1: Rear Panel

www.ElectricalPartManuals.com

Appendix I AC Schematic Drawing

AC schematic using bus differential only

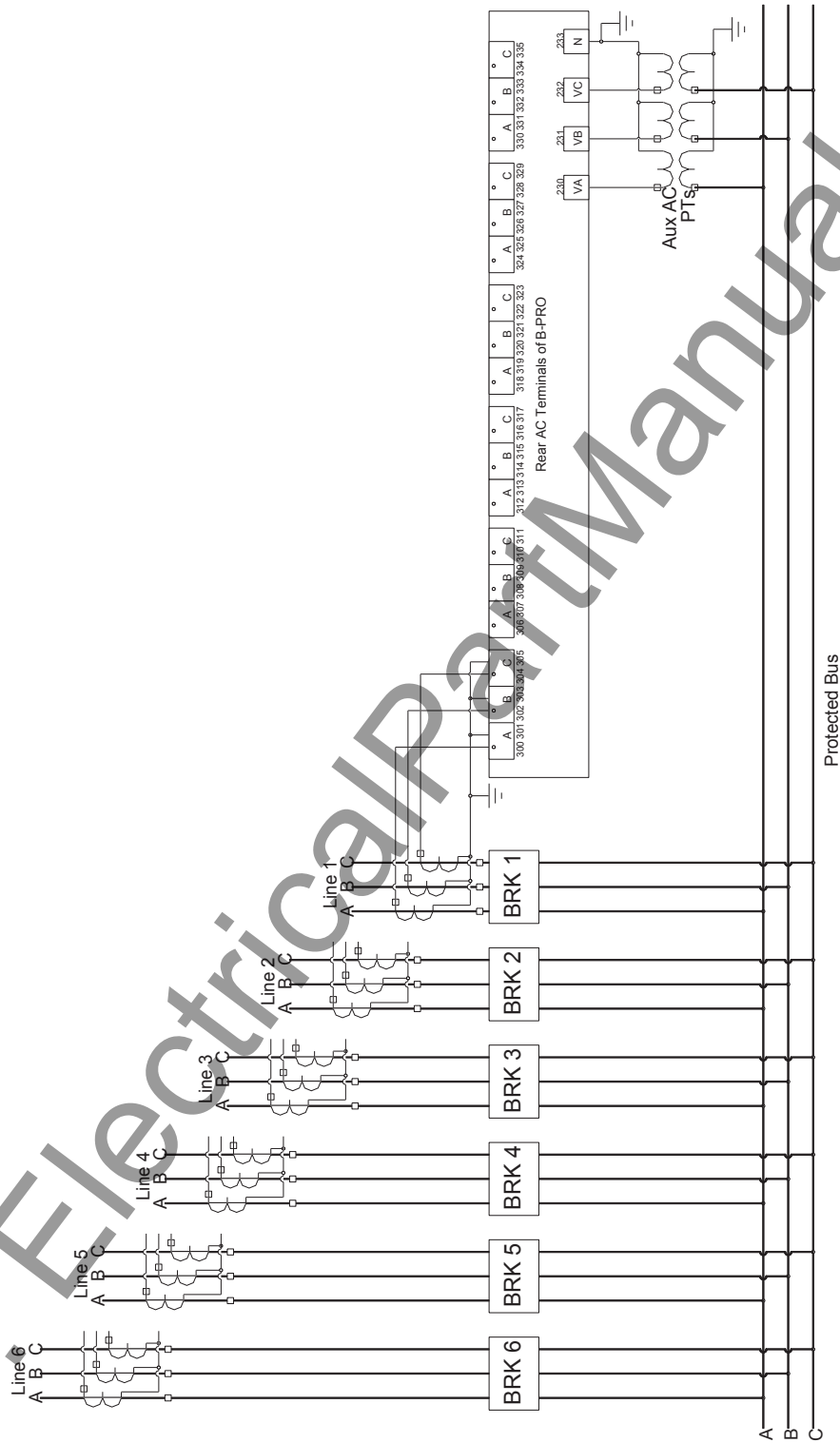

Figure I.1: AC Schematic (bus differential)

- Notes:
1. All CT's on lines connected GRD WYE.
 2. Lines 2 to 6 connected similarly to line 1.

AC schematic using bus and transformer differential only

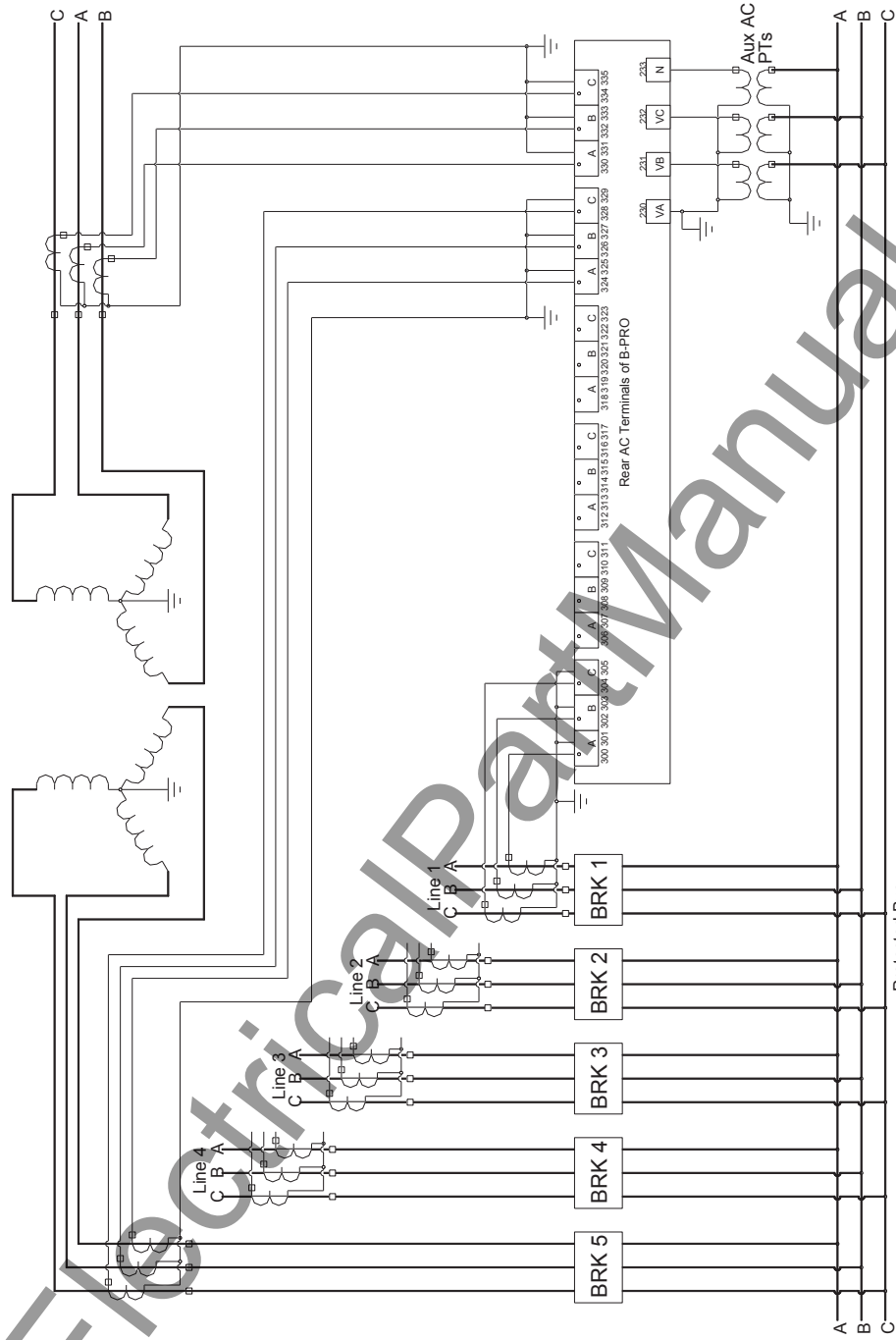

Figure I.2: AC Schematic (bus and transformer differential)

Notes:

1. All CT's to inputs 1 to 5 are connected GRD WYE.
2. CT's on input #6 can be either GRD WYE or DELTA.
3. Transformer connection can be any combination of WYE-DELTA windings.
4. For Input 6 (terminals 330-335), polarity might have to be physically or electrically rotated 180 degrees in settings to match bus protection CT polarities.

Appendix J DC Schematic Drawing

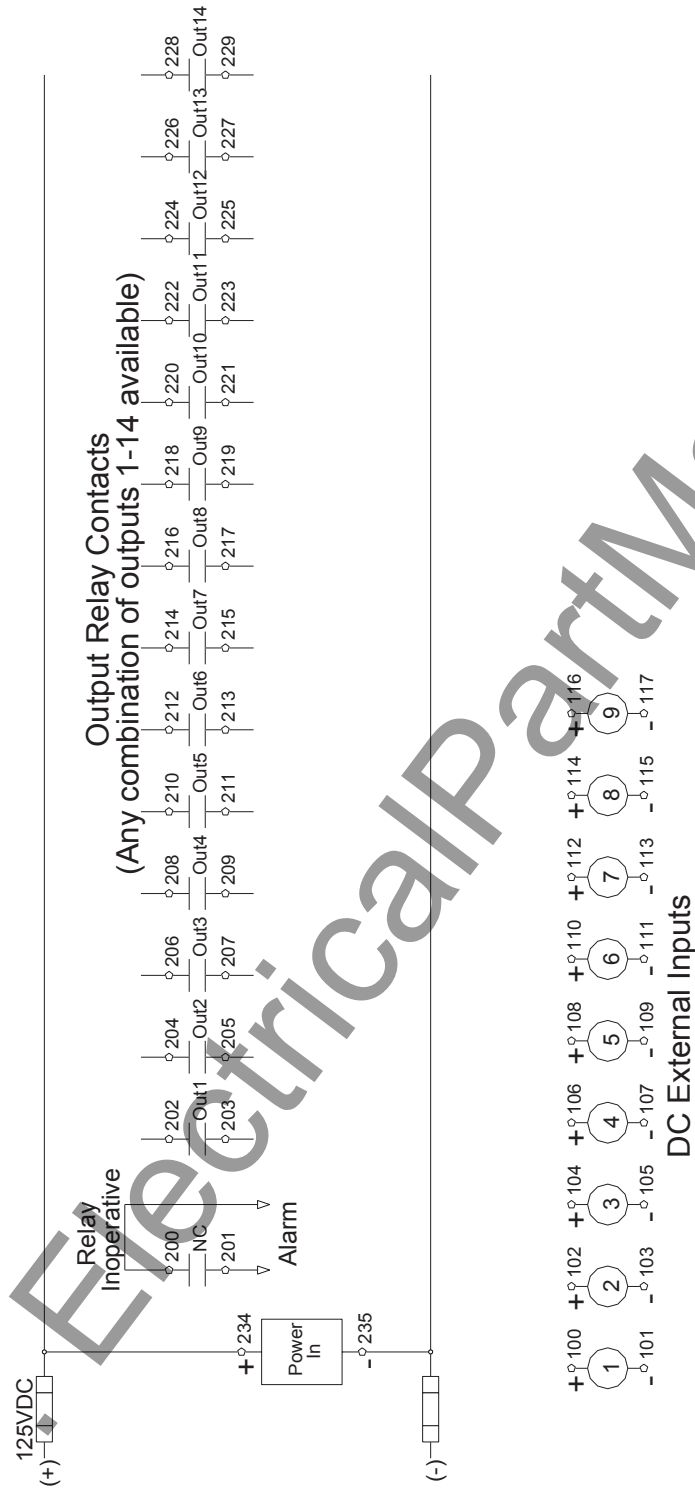

Figure J.1: DC Schematic

- Notes:
1. IRIG-B and comm ports shown separately on B-PRO rear panel layout drawing # 670003
 2. All output relays are N.O. and can be programmed to operate on any relay function.
 3. All outputs are rated tripping duty, interrupting via breaker aux "a" contact
 4. DC External Inputs are available for 48/125VDC or 125/250VDC ranges.

www.ElectricalPartManuals.com

Appendix K Bus Differential Function Setting Examples

Introduction

The B-PRO Bus Protection Relay provides low-impedance differential protection for transmission and distribution buses, for up to 6 three-phase inputs. The B-PRO is a per-unit based relay, meaning all secondary currents entering the relay are converted to per-unit values for protection calculations. Choosing the correct per-unit base for the current permits the development of standard protection settings that work for most bus protection applications. The resulting settings method only requires 2 calculations to implement.

The settings described in this technical note will provide a good balance between dependability and security of the protection system. This method also assumes the CTs have burdens within their ratings, and that the measured secondary current by the CTs is between 0.2 A and 15 A secondary.

Bus Differential (87B-1 and 87B-2) Protection Function Characteristic

The operating characteristic of the 87B function is shown in Figure 1. I_{Omin} is the minimum operating current for fault detection. I_{Rs} is the setting for the breakpoint between the region of slope $S1$ and the region of slope $S2$. I_{Rs} is normally used as the upper limit of the load range, or the protection zone used to detect bus faults during normal load conditions. The $S2$ region is therefore used for protection during through-fault events, where CT measurement errors can be quite large. The High Current Setting is an unrestrained differential element. Settings are described more completely in the B-PRO instruction manual.

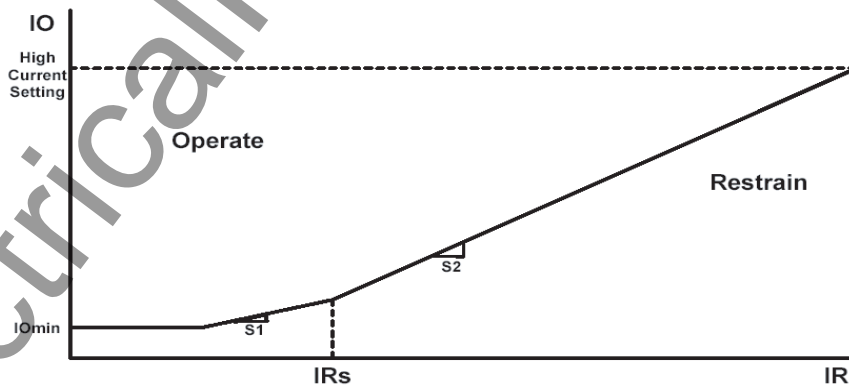

Figure K.2: 87B Operating Characteristic

In addition to this operating characteristic, the B-PRO includes a CT Saturation Detection algorithm that correctly identifies CT saturation due to external faults, and blocks the differential element from tripping.

While performing setting calculations for the B-PRO, the IO operate current is calculated by the equation:

$$IO = \left| \vec{I}_1 + \vec{I}_2 + \vec{I}_3 + \vec{I}_4 + \vec{I}_5 + \vec{I}_6 \right| A_{per\ unit}$$

The restraint current IR calculation is:

$$IR = \frac{|\vec{I}_1| + |\vec{I}_2| + |\vec{I}_3| + |\vec{I}_4| + |\vec{I}_5| + |\vec{I}_6|}{2} A_{per\ unit}$$

Settings Philosophy

The recommended settings method described in this technical note is simple: choose the MVA Base setting of the relay such that the maximum bus transfer load current is equal to the IRs setting in per-unit current. All other settings are related to the per-unit base current. The preferred setting for IRs is 2 per-unit, but there are some applications where a higher value is required. This method ensures that IRs is the upper limit setting for the load range, provides dependability for normal operating conditions, and provides adequate security for through-fault events.

The basic settings philosophy is to make sure operating and restraint current values (during normal operating conditions) fall in the load range. This means the S1 range accommodates the actual operating current, accounting for the maximum CT measurement error under any load condition. External fault conditions will be in the S2 or High Current range of the characteristic. Figure 2 describes recommended settings for most bus differential applications.

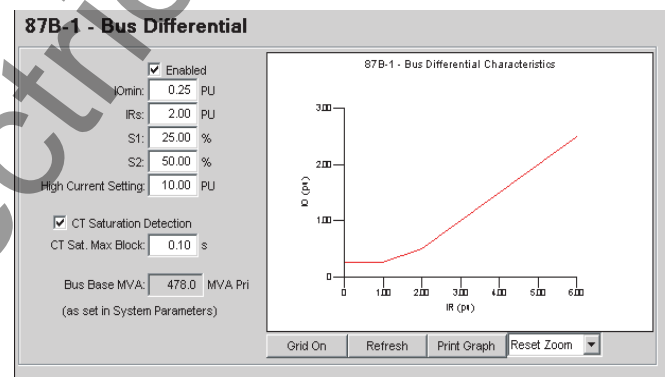

Figure K.3: 87B-1 settings

Settings Method

The clearest way to understand the proposed bus differential settings method is through a specific example. Figure 3 illustrates normal load conditions.

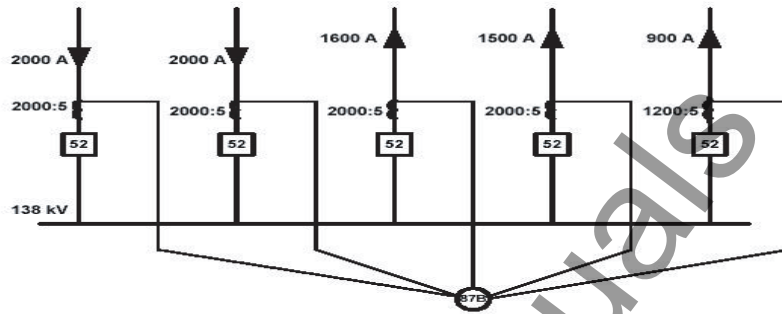

Figure K.4: Bus transfer load

Settings are developed using simple steps:

1. Enter Winding/CT connection information
2. Determine the maximum bus transfer current
3. Choose a value for IRs
4. Calculate the Bus Base MVA
5. Determine the CT Saturation Block Timer
6. Enter settings in the B-PRO

1. Enter Winding/CT Connection Information

Enter Winding and CT connection information to match the specific bus protection application, as in the example of Figure 4.

Winding/CT Connections

Differential Zones:

- Bus1
- Transformer
- Bus1 and Transformer
- Bus1 and Bus2

Transformer 3 Phase Capacity (MVA Pri):

Bus Side	Non-bus Side
Voltage (kV Pri): 230.0	115.0
Connection: Y	Y
Phase (deg): 0° (ref)	0°
	60.0

Current Inputs	Connect To	CT Connection	CT Phase (deg)	CT Turns Ratio (to 1)	Digital Control	External Input
1 [Input1]	Bus1	Y	0	400.0	<input checked="" type="checkbox"/>	<Not Used>
2 [Input2]	Bus1	Y	0	400.0	<input checked="" type="checkbox"/>	<Not Used>
3 [Input3]	Bus1	Y	0	400.0	<input checked="" type="checkbox"/>	<Not Used>
4 [Input4]	Bus1	Y	0	400.0	<input checked="" type="checkbox"/>	<Not Used>
5 [Input5]	Bus1	Y	0	240.0	<input checked="" type="checkbox"/>	<Not Used>
6 [Input6]	NC	Y	0°	100.0	<input checked="" type="checkbox"/>	<Not Used>

Figure K.5: Winding/CT Connections Settings

2. Determine the Maximum Bus Transfer Current

The maximum bus transfer current is going to be based on the CT primary ratings. For the example of Figure 3, there are many load flow configurations possible, but it is not possible to exceed an inflow of 4000 A_{pri} without exceeding at least one CT rating. Therefore, 4000 A_{pri} is the maximum bus transfer condition for this bus. It is possible, of course, for the maximum bus transfer current to be smaller than the rating limits of the CTs due to other system constraints.

3. Choose a Value for IRs

The IRs setting determines the break point between the slope S1 and slope S2. The IRs setting is also the upper limit of the load range of the B-PRO. For this recommended settings method, the maximum bus transfer current is equal to IRs in per-unit current. The preferred setting for IRs is 2 per-unit, which will work for most applications, but IRs can be any whole number 2 or greater. This method ensures the IR restraint current of the B-PRO for maximum bus transfer current is always within the upper limit of the load range.

4. Calculate the Bus Base MVA

The B-PRO does not have an explicit setting for the current base, but calculates the current base from the Bus Voltage and Bus Base MVA settings. Therefore, choosing the base current requires calculating the Bus Base MVA.

$$\text{Bus Base MVA} = \sqrt{3} \times \text{Bus Voltage} \times \text{Base Current}$$

$$\text{Maximum bus transfer current} = \text{IRs}$$

$$\text{Base Current} = \frac{\text{Maximum bus transfer current (A}_{pri}\text{)}}{\text{IRs (A}_{per\ unit}\text{)}}$$

For the configuration of Figure 3, the maximum bus transfer current = 4000A, and IRs = 2 per-unit

$$\text{Base Current} = \frac{4000 \text{ A}_{pri}}{2 \text{ A}_{per\ unit}} = 2000 \text{ A}$$

$$\text{Bus Base MVA} = \sqrt{3} \times 138 \text{ kV} \times 2000 \text{ A} = 478 \text{ MVA}$$

Enter this amount as a relay setting in System Parameters, as illustrated in Figure 5.

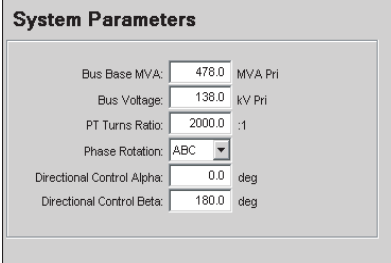

Parameter	Value	Unit/Label
Bus Base MVA	478.0	MVA Pri
Bus Voltage	138.0	kV Pri
PT Turns Ratio	2000.0	-1
Phase Rotation	ABC	
Directional Control Alpha	0.0	deg
Directional Control Beta	180.0	deg

Figure K.6: System Parameters settings

The maximum relay setting for the Bus Base MVA in the B-PRO is 10000 MVA. If the calculated Bus Base MVA exceeds this value, choose the next higher whole number value for IRs (3 per-unit in this example), and re-calculate the Bus Base MVA.

5. Determine the CT Saturation Block Timer

The settings method used assumes the CT Saturation Detector is enabled. When an external fault occurs on a feeder, it can look like an internal fault if the feeder CTs saturate sufficiently. The "saturation detection algorithm" detects this condition and blocks tripping. It does not block tripping for CT saturation during an internal fault.

Once the CT Saturation Detector has identified a CT saturation condition, the 87B function is blocked from tripping until the CT Saturation Max Block timer expires. This setting should be greater than the slowest fault clearing time for any of the feeders connected to the bus. A typical clearing time is 5 cycles, or 2 cycles to recognize the fault and 3 cycles for the circuit breaker to open. The minimum setting of 0.10 seconds provides some safety margin.

6. Enter Settings in the B-PRO

The un-restrained differential High Current Setting should be set at 5 x IRs. For this example, $5 \times 2 = 10$ per-unit. IOmin is set at 0.25 per-unit, other than for applications with widely diverse CT ratios. S1 is recommended to be at 25%, and S2 at 50%, as shown in Figure 2.

To help determine whether any CT saturation will occur for any of the external fault conditions, use ERLPhase CT Saturation Program located on the CD provided with the relay.

Widely Diverse CT Ratios

"Widely diverse CT ratios" differ by more than 5-to-1 (for example, 1200:5 and 8000:5). With widely diverse CT ratios, there is a possibility of false tripping under light load conditions. Consider a case such as Figure 6: Widely diverse CT ratios

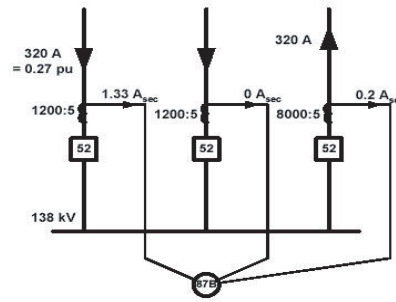

Figure K.7: Widely diverse CT ratios

Assume that the base current is chosen in the same way described by this Technical Note. Thus the *maximum bus transfer current* through this bus is 2400 A, and the *base current* for the bus differential protection is $2400 \text{ A}/2 = 1200 \text{ A}$. When the secondary current of a nominally 5A CT is as small as 0.2 A, there is a possibility that the current may be interpreted as close to zero amps due to CT error and A-to-D conversion error. Assuming the worst case, 0.2 amps is interpreted as zero amps by the relay.

Then, for this light load condition the operating current, I_O , is perceived as $320 - 0 = 320$ primary amps. On a 1200 A base this is 0.27 per-unit, which is above the recommended setting for I_{Omin} , namely 0.25 per-unit. For this case, it is recommended to set I_{Omin} to 0.4 per-unit in order to prevent possible false tripping of the bus.

Appendix L Function Logic Diagram

Diagram in plastic sleeve.

www.ElectricalPartManuals.com

www.ElectricalPartManuals.com

Appendix M Analog Phase Shift Table

+30°(-330°) Shift	+60°(-300°) Shift
$I_A = \frac{I_a - I_b}{\sqrt{3}}$	$I_A = \frac{I_a - 2I_b + I_c}{3}$
$I_B = \frac{I_b - I_c}{\sqrt{3}}$	$I_B = \frac{I_b - 2I_c + I_a}{3}$
$I_C = \frac{I_c - I_a}{\sqrt{3}}$	$I_C = \frac{I_c - 2I_a + I_b}{3}$

+90°(-270°) Shift	+120°(-240°) Shift
$I_A = \frac{I_c - I_b}{\sqrt{3}}$	$I_A = \frac{2I_c - I_a - I_b}{3}$
$I_B = \frac{I_a - I_c}{\sqrt{3}}$	$I_B = \frac{2I_a - I_b - I_c}{3}$
$I_C = \frac{I_b - I_a}{\sqrt{3}}$	$I_C = \frac{2I_b - I_c - I_a}{3}$

+150°(-210°) Shift	-30°(+330°) Shift
$I_A = \frac{I_c - I_a}{\sqrt{3}}$	$I_A = \frac{I_a - I_c}{\sqrt{3}}$
$I_B = \frac{I_a - I_b}{\sqrt{3}}$	$I_B = \frac{I_b - I_a}{\sqrt{3}}$
$I_C = \frac{I_b - I_c}{\sqrt{3}}$	$I_C = \frac{I_c - I_b}{\sqrt{3}}$

-60°(+300°) Shift	-90°(+270°) Shift
$I_A = \frac{I_a - 2I_c + I_b}{3}$	$I_A = \frac{I_b - I_c}{\sqrt{3}}$
$I_B = \frac{I_b - 2I_a + I_c}{3}$	$I_B = \frac{I_c - I_a}{\sqrt{3}}$
$I_C = \frac{I_c - 2I_b + I_a}{3}$	$I_C = \frac{I_a - I_b}{\sqrt{3}}$

-120°(+240°) Shift	-150°(+210°) Shift
$I_A = \frac{2I_b - I_c - I_a}{3}$	$I_A = \frac{I_b - I_a}{\sqrt{3}}$
$I_B = \frac{2I_c - I_a - I_b}{3}$	$I_B = \frac{I_c - I_b}{\sqrt{3}}$
$I_C = \frac{2I_a - I_b - I_c}{3}$	$I_C = \frac{I_a - I_c}{\sqrt{3}}$

0° Shift	±180° Shift
$I_A = \frac{2I_a - I_b - I_c}{3}$	$I_A = \frac{I_c - 2I_a + I_b}{3}$
$I_B = \frac{2I_b - I_c - I_a}{3}$	$I_B = \frac{I_a - 2I_b + I_c}{3}$
$I_C = \frac{2I_c - I_a - I_b}{3}$	$I_C = \frac{I_b - 2I_c + I_a}{3}$

Appendix N How to Start the CT Saturation Calculator

The CT Saturation Calculator will assist you with setting the B-PRO relay. This program is a Microsoft Excel spreadsheet. It is available from the downloads page on ERLPhase's Website (www.erlphase.com/sub-downloads.htm). The CT Saturation Calculator tool is also included on the B-PRO software CD.

Run from the CD

- 1 Insert the B-PRO CD into your CD-ROM drive.
- 2 If the CD does not open automatically, browse the CD and locate the "CD.exe" file in the root of the CD. Double-click on the file to run it.
- 3 Select either the text "B-PRO Bus Protection", located below the image of the relay, or the "B-PRO" text in the upper right hand corner of the start page.
- 4 Select the text "Install CT Saturation Software". This will launch Microsoft Excel either directly or from within your default WEB browser. Refer to the instructions at the top of the spreadsheet for further descriptions.

Copy to your hard drive

- 1 Use Windows File Manager to copy "CT_Sat.xls" from the B-PRO CD to a directory on your local hard drive.
- 2 When you need to access the program either double-click on the file or launch Microsoft Excel and use the standard "File" "Open" menu items to start the spreadsheet. You can also create a short cut icon on your desktop to run the CT program for your convenience.

www.ElectricalPartManuals.com

Index

Numerics

27 Undervoltage 4-7
46-50/46-51/67 Negative sequence overcurrent 4-18
50/51/67 Phase overcurrent 4-14
50BF Breaker failure 4-12
50N/51N/67 Neutral overcurrent 4-16
59 Overvoltage 4-6
60 Loss of potential 4-7
81 over/under frequency 4-8
87B Bus differential 4-1
87T Transformer differential 4-9

A

ac and dc wiring 7-1
Access 3-13
Alarm 3-3
analog phase shift table M-1

B

Back view 1-4
backward compatibility 5-10
baud rate
 direct serial link 2-6
 modem link 2-7
Bus protection 4-1

C

Calibrate 3-13, 6-1
Change 3-13
clear target 3-3
communication
 internal modem link 2-3
 with the relay 2-2
communication ports 2-8
communication wiring 7-1
communication with the relay 2-2
converting a settings file 5-10
creating a setting file from an older version 5-11
CT Saturation Calculator N-1

D

date & time 3-3
Diagnostics 3-13
Display information 3-4

E

Erase 3-13
Event log 3-12, 4-24
external inputs 5-8

F

firmware update 2-12
Front display 3-1
Front view 1-3, 3-1, 3-2

G

graphing protection functions 5-4
grounding 2-1

H

HyperTerminal 2-5

I

ID 3-10
Inputs
 external 1-4
Inputs 1 to 6 4-11
Installation
 software 5-2
IRIG-B 3-2
IRIG-B time input 2-1

L

LED Lights 3-2
List 3-11
load from Offliner 3-11

M

Maintenance 3-13
Maintenance menu 2-5
maintenance menu 2-11
Metering 3-10, 3-11
Modbus 3-13

O

Offliner features 5-2
Offliner settings 3-1
Output contacts 1-4
Outputs 3-13

P

Password 3-5, 3-13
physical mounting 7-1
Ports 3-13
power supply 2-1
ProLogic 4-20
Push buttons 3-3

Q

Quit 3-13

R

record
 duration and extension 4-22

- storage, retrieval and analysis 4-22
- record length 5-10
- RecordBase View 5-12
- Recording 4-21
- Records 3-11
- Relay functional 3-1, 3-2
- Relay inoperative alarm 1-4
- retrieve to Offliner 3-11

S

- SCADA 2-7, 3-13
- sending a new setting file 5-10
- Service 3-2
- setting the baud rate 2-6
- Settings 3-9, 3-10
- settings 3-10
- Setup 3-13
- Start-up 3-1
- system requirements 5-1
 - hardware 5-1
 - operating system 5-1

T

- Target 3-3
- terminal program setup 2-5
- Test mode 3-1, 3-2
- Testing
 - external inputs 6-2
 - loss of potential 6-3
 - output relay contacts 6-2
- Time 3-13
- tool bar 5-2
- Transformer protection 4-9

U

- Utilities 3-13

V

- Version descriptions 1-iii
- View 3-13
- view logs 3-3
- view readings 3-3

W

- Watchdog C-1

Software Installation Instructions

The CD-ROM contains software and the User Manual for the B-PRO Bus Protection Relay.

Software is installed directly from the CD-ROM to a Windows PC. Alternatively, you can create installation diskettes to install software on computers without a CD-ROM drive.

The CD-ROM contains the following:

- B-PRO *Offliner* Settings: Offliner settings program for the B-PRO relay
- B-PRO Firmware: Firmware and installation instructions.
- B-PRO User Manual: B-PRO manual in PDF format

To Install Software on your Computer

Insert the CD-ROM in your drive. The CD-ROM should open automatically. If the CD-ROM does not open automatically, go to Windows Explorer and find the CD-ROM (usually on D drive). Open the CD.exe file to launch the CD-ROM.

To install the software on your computer, click the desired item on the screen. The installation program launches automatically. Installation may take a few minutes to start.

To view the B-PRO User Manual you must have Adobe Acrobat on your computer. If you need a copy, download a copy by clicking on Download Adobe Acrobat.

www.ElectricalPartManuals.com