

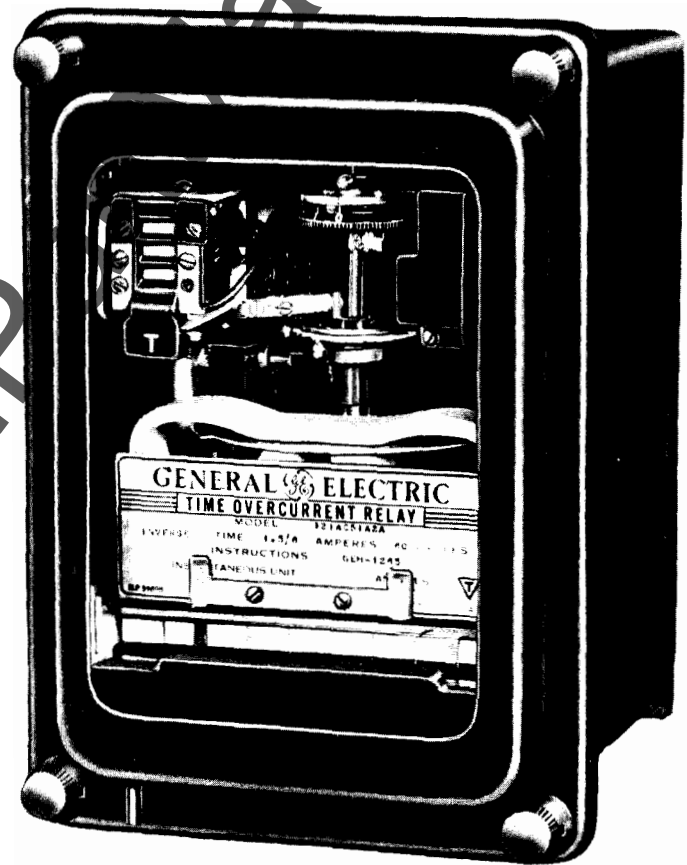

**INSTRUCTIONS**

**GEH-1753E**  
SUPERSEDES GEH-1753D

# TIME OVERCURRENT RELAYS



**Types**

**IAC51A  
IAC51D**

**IAC51B  
IAC51R  
IAC52B**

**IAC51C  
IAC52A**

**SWITCHGEAR DEPARTMENT**

**GENERAL  ELECTRIC**

**PHILADELPHIA, PA.**

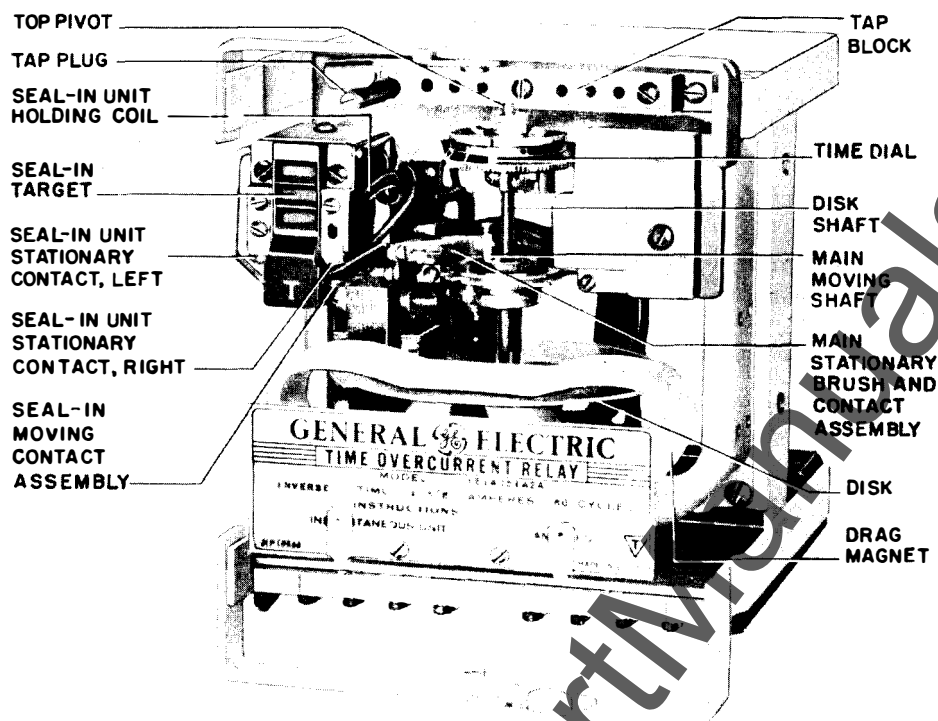

A - (Front View)

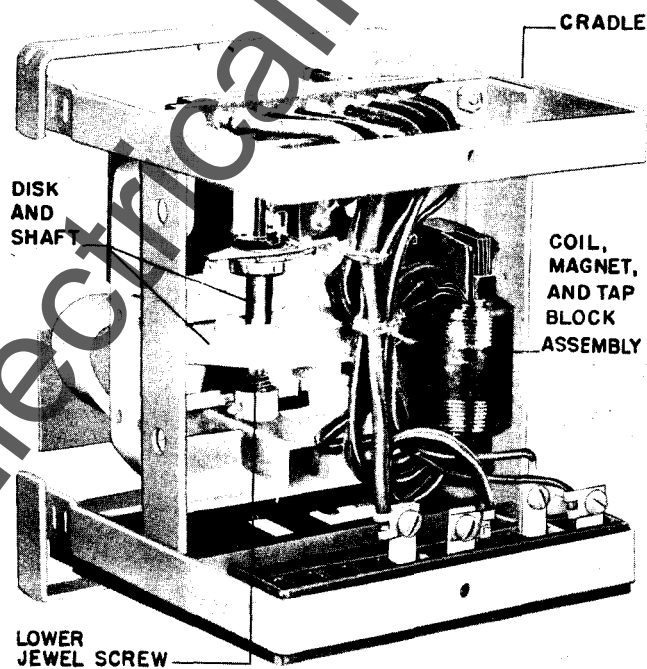

Fig. 1 The Induction Unit for Type IAC Relays  
B - (Rear View)

www.ElectricalPartsmaterials.com

# TIME-OVERCURRENT RELAYS

## TYPE IAC

### INTRODUCTION

com

Type	Contact Circuits	Instantaneous Unit	AC Trip Unit	Induction Unit	Outline & Panel Drilling	Internal Connection
IAC51A(-)A	One	No	No	One	Fig. 20	Fig. 11
IAC51B(-)A	One	Yes	No	One	Fig. 20	Fig. 12
IAC51C(-)A	One	No	Yes	One	Fig. 20	Fig. 13
IAC51D(-)A	One	No	No	Three	Fig. 21	Fig. 14
IAC51R(-)A	One	Yes	Yes	One	Fig. 20	Fig. 15
IAC52A(-)A	Two	No	No	One	Fig. 20	Fig. 16
IAC52B(-)A	Two	Yes	No	One	Fig. 20	Fig. 17

The Type IAC relays comprise a group of relays that are employed to protect against overcurrent on single-phase and polyphase circuits. The various relays in this IAC group are identified by model numbers, and the relays differ in the number of circuits they close, the length of time delay and features that are determined by the characteristics of the protected circuit.

These relays consist of an induction unit or an induction unit with an instantaneous unit which

permits instantaneous tripping for extremely high currents, or an induction unit with an a-c tripping unit for use where d-c power is unavailable or a-c tripping is preferred. Since practically all IAC relays are composed of various combinations of the above - that is, the induction unit, the instantaneous unit and the a-c tripping unit - they are for convenience, described separately in the following text. The above table indicates the units comprising each type and also lists the internal connections and outline and panel drilling diagrams.

## INDUCTION UNIT

### INTRODUCTION

The induction unit is the basic unit in all IAC relays. Fig. 1 shows the induction unit mounted in the cradle. These units are of the induction-disk construction type. The disk is actuated by a current operating coil on a laminated U-magnet. The disk shaft carries the moving contact which completes the alarm or trip circuit when it touches the stationary contact or contacts. The disk shaft is restrained by a spiral spring to give the proper contact-closing current and its motion is retarded by a permanent magnet acting on the disk to give the correct time delay.

There is a seal-in unit mounted on the front to the left of the shaft. This unit has its coil in series and its contacts in parallel with the main contacts such that when the main contacts close the seal-in unit picks up and seals in. When the seal-in unit picks up, it raises a target into view which latches up and remains exposed until released by pressing a button beneath the lower left corner of the cover.

### APPLICATION

The induction unit is the main unit in all IAC relays, supplying the inverse time delay characteristics of the relay and sounding an alarm or tripping the breakers for overload currents which cause it to close its contacts.

### OPERATING CHARACTERISTICS

The induction unit may have one or two circuit-closing contacts which close as the current increases to the pick-up value as set on the tap block. The time delay in closing the contacts is determined by the setting of the time dial (Fig. 1). The time-current characteristics are shown in Fig. 2.

### RATINGS

The induction element is designed to use any one of three operating coils, each having a different combination of taps as follows: 4, 5, 6, 8, 10, 12 and 16 amperes; 1.5, 2.0, 2.5, 3.0, 4.0, 5.0 and 6.0 amperes; 0.5, 0.6, 0.8, 1.0, 1.2, 1.5 and 2.0 amperes.

*These instructions do not purport to cover all details or variations in equipment nor to provide for every possible contingency to be met in connection with installation, operation or maintenance. Should further information be desired or should particular problems arise which are not covered sufficiently for the purchaser's purposes, the matter should be referred to the General Electric Company.*

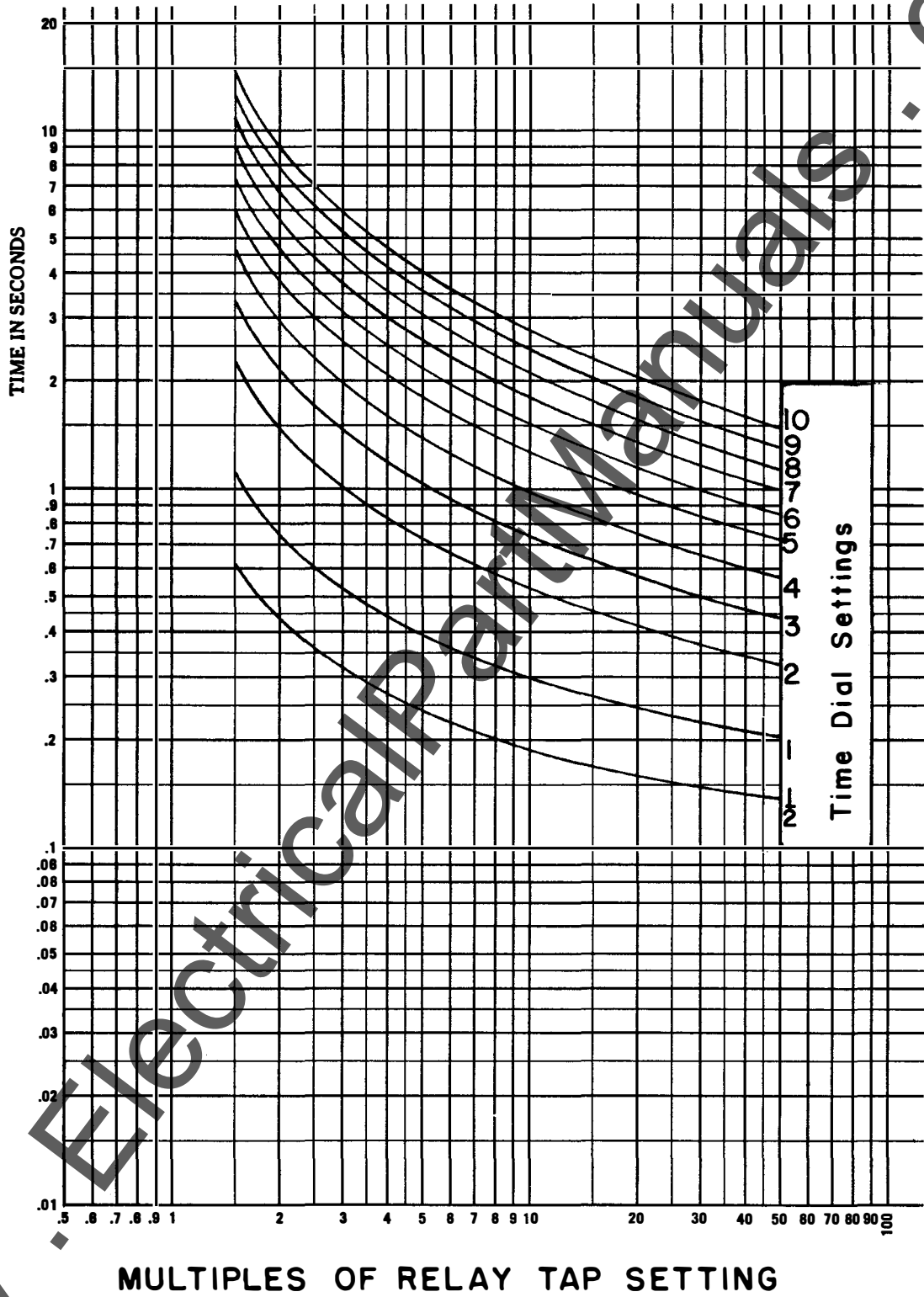

Fig. 2 Time-current Curves of Type IAC Relays with Inverse-time Characteristics

The current-closing rating of the contacts is 30 amperes for voltages not exceeding 250 volts. The current-carrying ratings are affected by the selection of the tap on the target and seal-in coil as indicated in the following table:

FUNCTION	Amperes, AC or DC	
	2-Amp Tap	0.2 Amp Tap
Operating Range	2-30	0.2-2
Tripping Duty	30	5
Carry Continuously	3	0.3
Resistance	0.13	7
Impedance @ 60 cycles	0.53	52

If the tripping current exceeds 30 amperes, an auxiliary relay should be used, the connections being such that the tripping current does not pass through the contacts or the target and seal-in coils of the protective relay.

### BURDENS

Burdens for the standard coils are given in the following table. These are calculated burdens at five amperes based on burden of minimum tap.

Volt-ampere burdens for the lowest tap on any of the three coils can be determined for any value of current, up to 20 times tap setting, from Fig. 3.

Coil Amperes	Freq.	Tap	Volt-Amps	Imp. Ohms	P F
4-16	60	4.0	8.8	0.35	0.29
	50	4.0	8.0	0.32	0.31
	25	4.0	7.5	0.30	0.36
1.5-6.0	60	1.5	59.0	2.36	0.26
	50	1.5	52.0	2.08	0.28
	25	1.5	48.0	1.92	0.34
0.5-2.0	60	0.5	530.0	21.2	0.26
	50	0.5	470.0	18.8	0.28
	25	0.5	430.0	17.2	0.34

Fig. 3 (K-6306891)

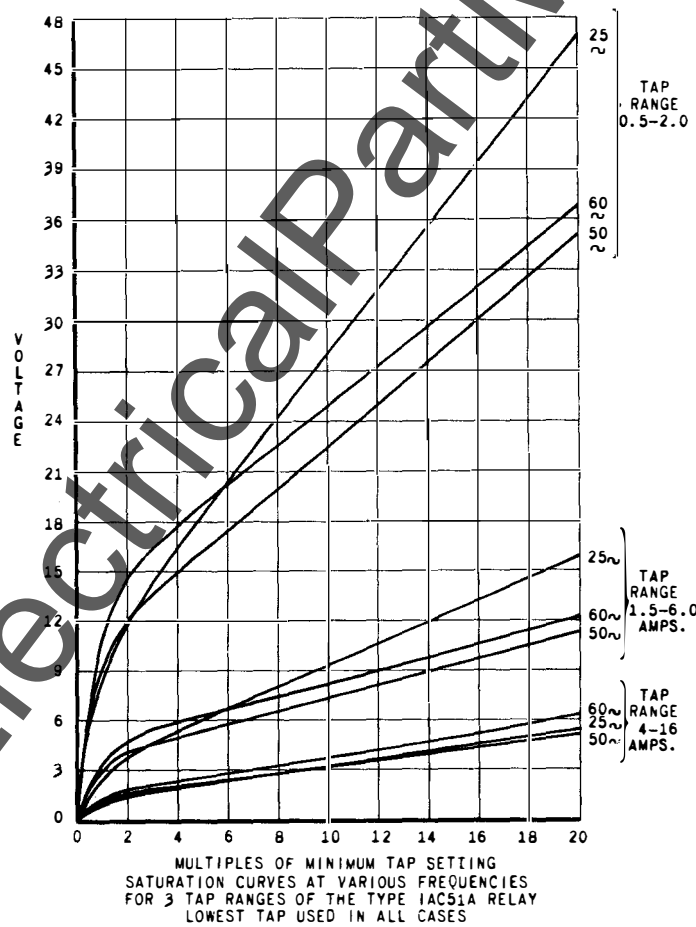

Fig. 3 Saturation Curves for Lowest Taps of the Induction Unit of Type IAC Relays with Inverse-time Characteristics

DEVICE FUNCTION NUMBERS FOR USE WITH ALL EXTERNAL DIAGRAMS

- 50 - Instantaneous Unit
- 51 - Overcurrent, Relay, Type IAC
- 51N - Ground Overcurrent Relay, Type IAC
- 52 - Power Circuit Breaker
- SI - Seal-in Unit, with Target
- TC - Trip Coil
- A - Auxiliary contact, closed when breaker closes.

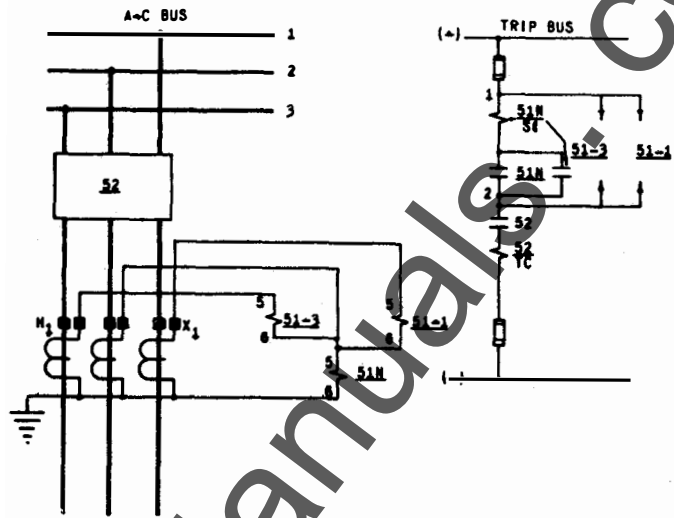

Fig. 4 External Connections of Three Type IAC51A Relays Used for Phase-to-Phase and Ground Overcurrent Protection of a 3-Phase Circuit

Fig. 4 (K-6375667)

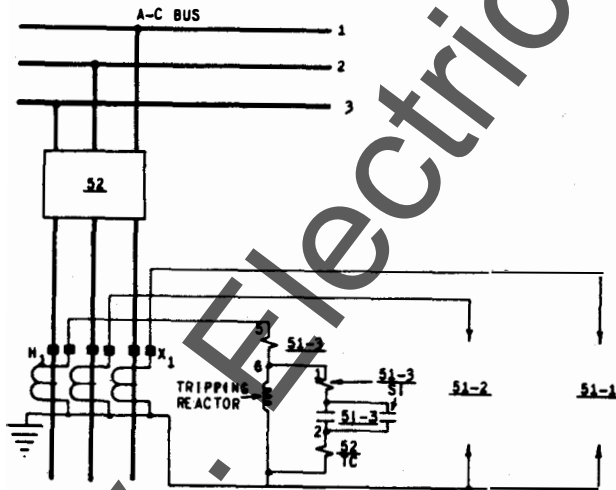

Fig. 5 External Connections of Three Type IAC51A Relays Used in Conjunction With Tripping Reactors For Protection of a Three-Phase Circuit

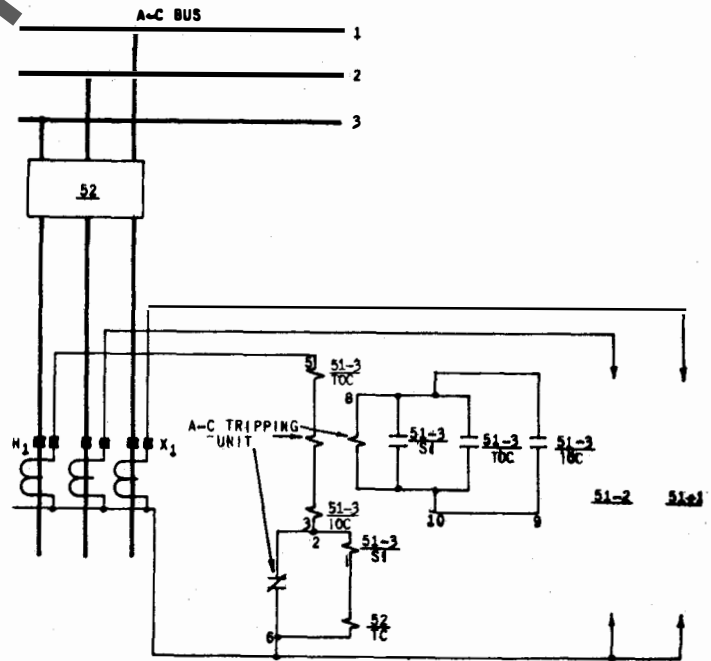

Fig. 6 External Connections of Three Type IAC51R Relays Used for 3-Phase Circuit Protection

Fig. 5 (K-6375668)

Fig. 6 (K-6375666)

## INSTANTANEOUS UNIT

### INTRODUCTION

The instantaneous unit is a small instantaneous hinge-type unit which may be mounted on the right front side of the induction unit (See Fig. 7). Its contacts are normally connected in parallel with the contacts of the main unit. Its coil is connected in series with the operating coil of the main unit.

When the current reaches a predetermined value, the instantaneous unit operates, closing the contact circuit and raising its target into view. The target latches in the exposed position until released by pressing the button beneath the lower left-hand corner of the relay cover.

### APPLICATION

The instantaneous unit is used on certain IAC relay models to provide instantaneous tripping for current exceeding a predetermined value.

### OPERATING CHARACTERISTICS

The instantaneous element operates over a 4 to 1 range and has its calibration stamped on a scale

mounted beside the adjustable pole piece. Time-current characteristics are shown in Fig. 10.

### RATINGS

The instantaneous unit is designed to use either of two coils having pickup ranges of 10 to 40, and 20 to 80 amperes respectively. The current-closing rating of the contacts is 30 amperes for voltages not exceeding 250 volts.

### BURDENS

Burden data on the instantaneous unit coils are given in the following table:

Coil	Freq.	Amp.	Volt Amp	Imp. Ohms	P F
10-40	60	5	0.83	0.033	0.95
	50	5	0.80	0.032	0.95
	25	5	0.65	0.027	0.98
20-80	60	5	0.21	0.008	0.95
	50	5	0.20	0.008	0.95
	25	5	0.15	0.007	0.98

Fig. 7 (8006998)

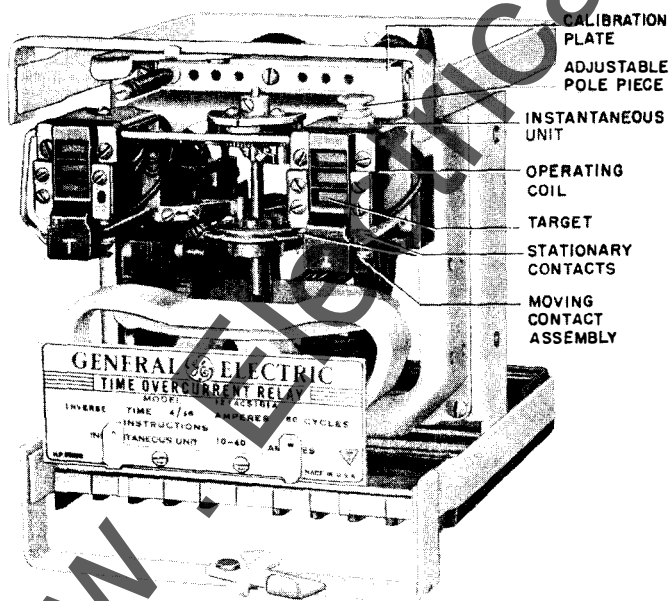

Fig. 8 (8007060)

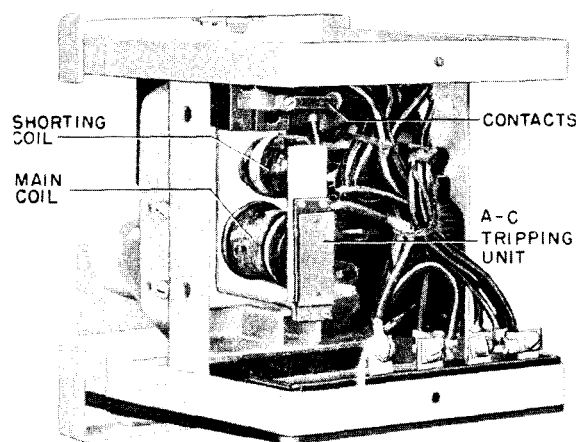

Fig. 7 Type IAC Relay With An Instantaneous Unit

Fig. 8 Type IAC Relay With An A-C Tripping Unit

## A-C TRIPPING UNIT

### INTRODUCTION

The a-c tripping unit is a Type REA relay unit designed to energize a circuit breaker trip coil from its associated current transformer upon the operation of the main unit of the IAC relay. It transfers the current from the secondary of the current transformer into the trip coil and removes the current from the trip coil when the breaker trips.

The tripping unit is mounted on the rear of the frame opposite the tapped operating coil of the induction unit (see Fig. 8). The operation of this unit is illustrated in Fig. 9. The secondary current circulates through the induction unit current coil and the main coil of the REA auxiliary tripping unit, returning through the REA contacts to the current transformer. Normally, most of the flux generated by the main REA coil passes through the upper limb of the magnetic structure and holds the armature firmly against this limb. When the contacts of the induction unit close, the shorting coil of the REA is short-circuited and current flows in this coil by transformer action, causing a redistribution of flux which actuates the armature and the REA contacts. The opening of the REA contacts causes the secondary current to flow through the trip coil which trips the breaker.

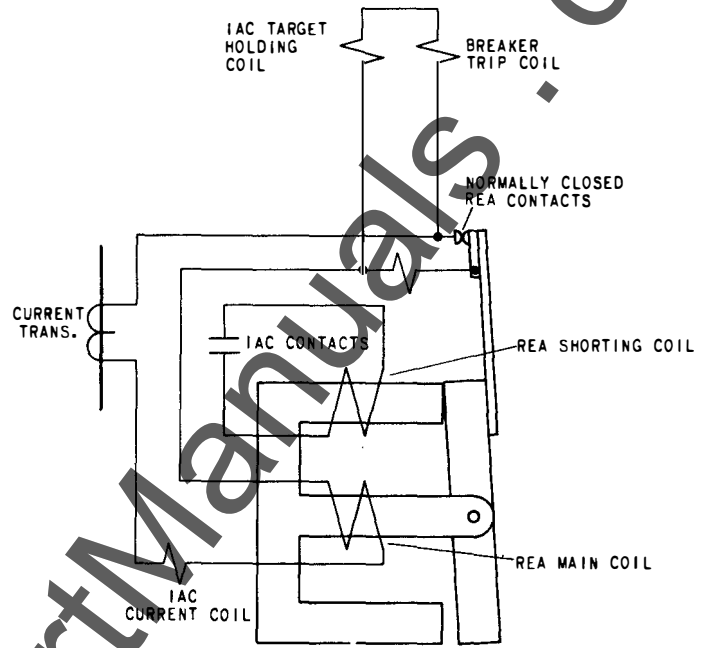

Fig. 9 Diagram Illustrating Operation of Type IAC Relays Having An A-C Tripping Unit

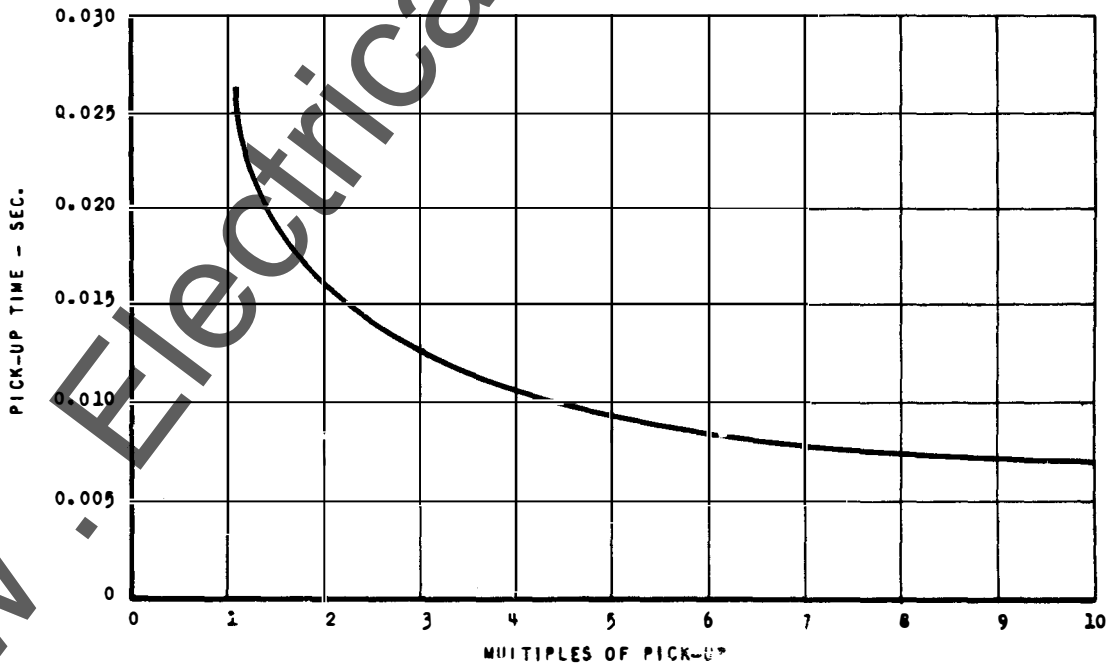

Fig. 10 Time-current Characteristics of Instantaneous Unit

**APPLICATION**

The a-c tripping unit is used in Type IAC relays where a reliable direct-current tripping source is not available and it is necessary to trip the breaker from the current-transformer secondary.

**RATINGS**

The a-c tripping unit has a continuous rating of five amperes but will operate on a minimum current of 3.5 amperes. They should be used with three-ampere trip coils. The contacts of these units will transfer current transformer secondary current up to 100 amperes. For applications where the secondary current exceeds 100 amperes, the REA11B relay,

which has contacts rated 200 amperes, can be used in conjunction with IAC overcurrent relays. The REA11B is not mounted inside the IAC case.

**BURDENS**

Burdens of the REA unit are given in the following table:

Frequency	Amp	Impedance in Ohms	P F	Volt-Amperes
60	5	0.49	0.80	12.2
50	5	0.33	0.85	8.4
25	5	0.23	0.62	5.8

**RECEIVING, HANDLING AND STORAGE**

These relays, when not included as a part of a control panel, will be shipped in cartons designed to protect them against damage. Immediately upon receipt of the relay, an examination should be made for any damage sustained during shipment. If injury or damage resulting from rough handling is evident, a claim should be filed at once with the transportation company and the nearest Sales Office of the General Electric Company notified promptly.

Reasonable care should be exercised in un-

packing the relay in order that none of the parts are injured or the adjustments disturbed. If the relays are not to be installed immediately, they should be stored in their original cartons in a place that is free from moisture, dust, and metallic chips. Foreign matter collected on the outside of the case may find its way inside when the cover is removed and cause trouble in the operation of the relay.

Fig. 11 (K-6209658)

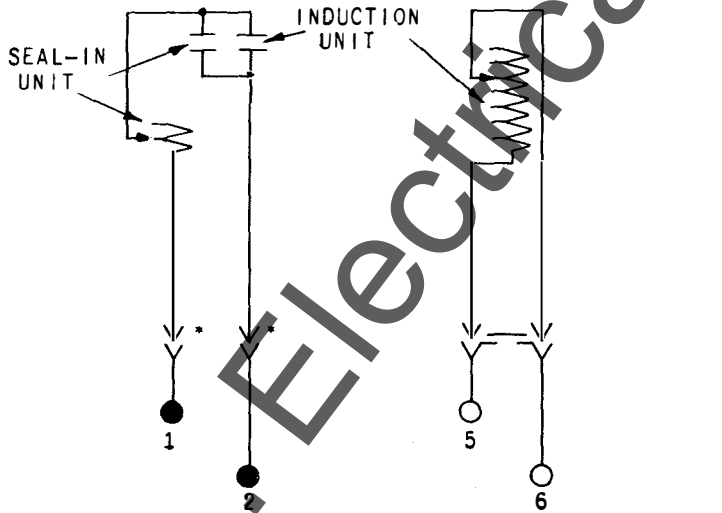

INTERNAL CONNECTIONS (FRONT VIEW) \* = SHORT FINGER

Fig. 12 (K-6209661)

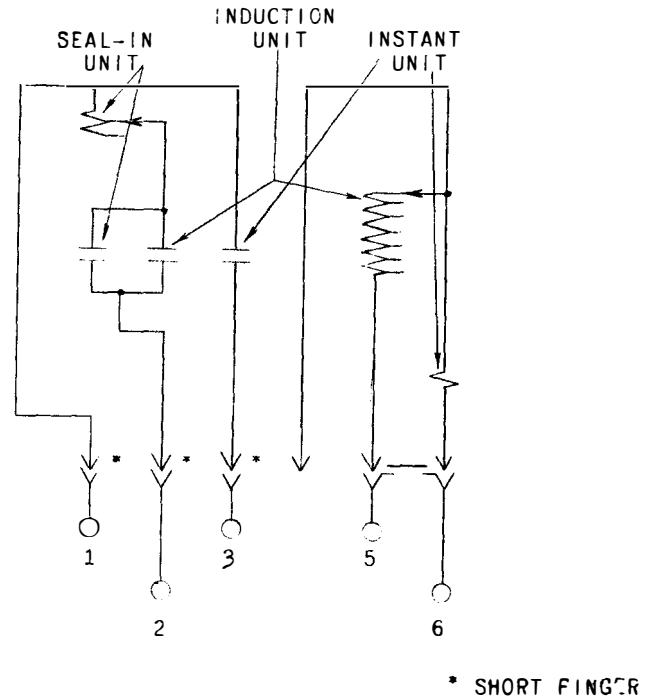

\* SHORT FINGER

Fig. 11 Internal Connections for the Type IAC5IA Relay (Front View)

Fig. 12 Internal Connections for the Type IAC5IB Relay (Front View)

GEH-1753 Time Overcurrent Relays Type IAC

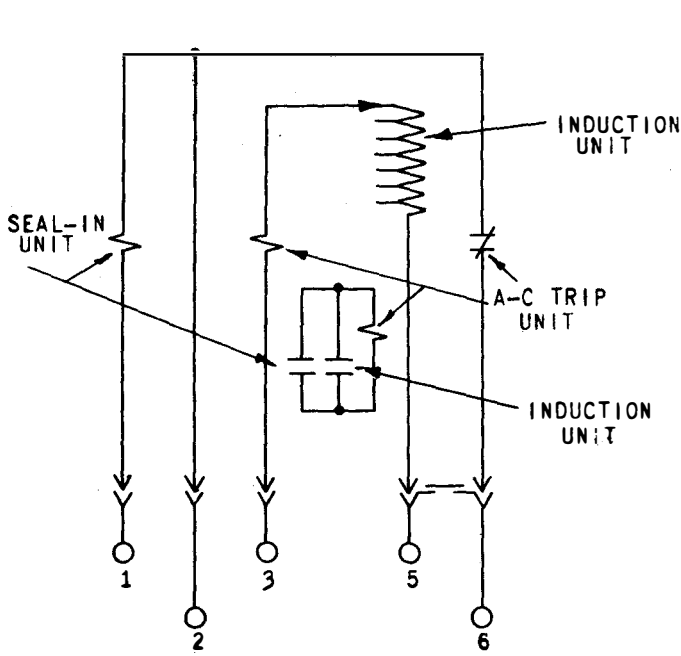

Fig. 13 Internal Connections for the Type IAC510 Relay (Front View)

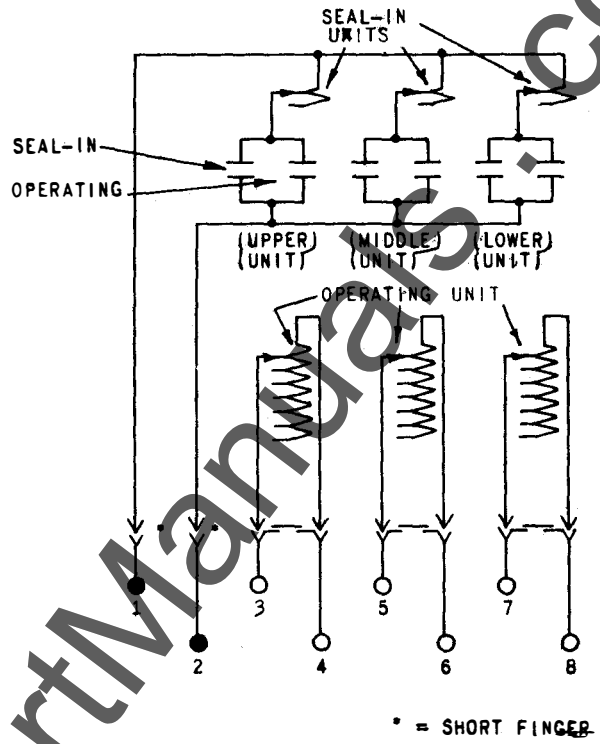

Fig. 14 Internal Connections for the Type IAC51D Relay (Front View)

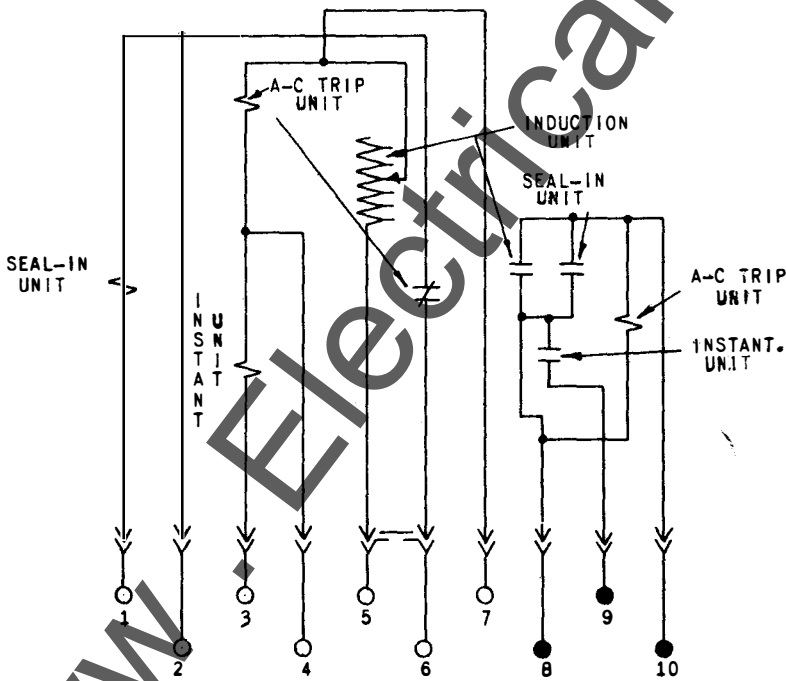

Fig. 15 Internal Connections for the Type IAC51R Relay (Front View)

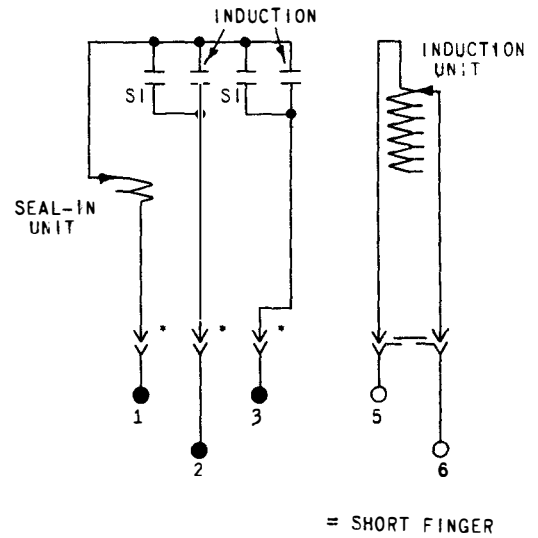

Fig. 16 Internal Connections for the Type IAC52A Relay (Front View)

Fig. 13 (K-6209660)

Fig. 14 (K-6209659)

Fig. 15 (K-6209294)

Fig. 16 (K-6209662)

Fig. 17 (K-6209663)

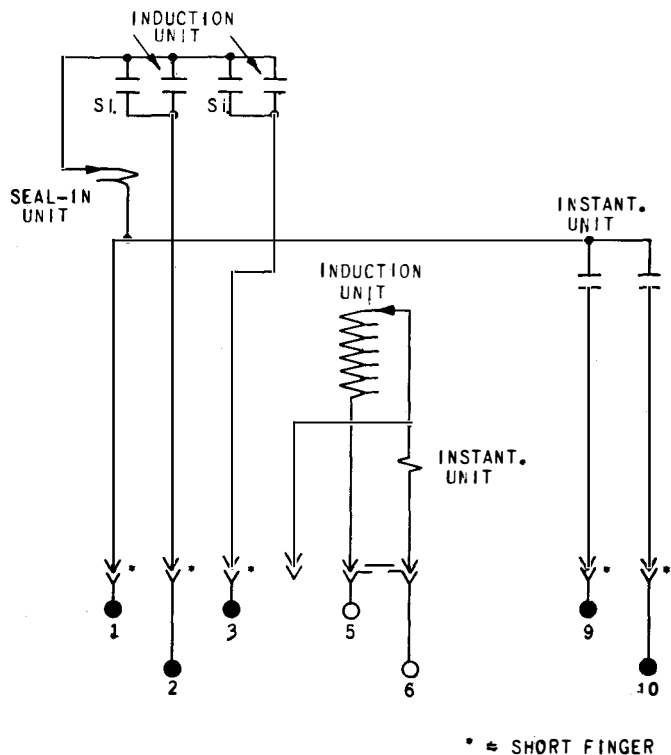

Fig. 17 Internal Connections for the Type IAC52B Relay (Front View)

Fig. 18 (K-6154399)

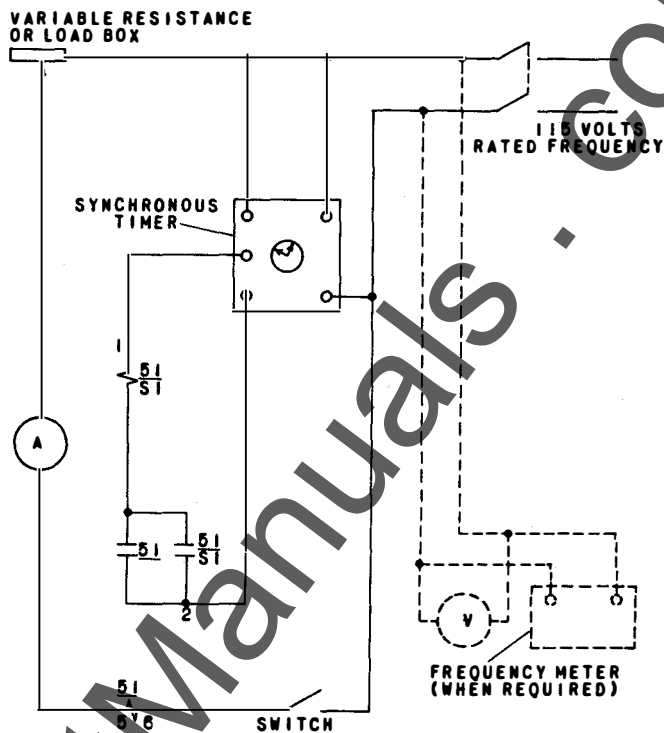

Fig. 18 Testing Connections for Type IAC Relays such as Type IAC51A

Fig. 19 (8025039)

## INSTALLATION

### LOCATION

The location should be clean and dry, free from dust and excessive vibration, and well lighted to facilitate inspection and testing.

### MOUNTING

The relay should be mounted on a vertical surface. The outline and panel diagrams are shown in Figs. 20 and 21.

### CONNECTIONS

Internal connection diagrams for the various relay types are shown in Fig. 11 to 17 inclusive. Typical wiring diagrams are given in Fig. 4 to 6 inclusive.

One of the mounting studs or screws should be permanently grounded by a conductor not less than No. 12 B&S gage copper wire or its equivalent.

### INSPECTION

At the time of installation, the relay should be inspected for tarnished contacts, loose screws, or other imperfections. If any trouble is found, it should be corrected in the manner described under MAINTENANCE.

#### \* CAUTION:

Every circuit in the drawout case has an auxiliary brush. It is especially important on current

circuits and other circuits with shorting bars that the auxiliary brush be bent high enough to engage the connecting plug or test plug before the main brushes do. This will prevent CT secondary circuits from being opened.

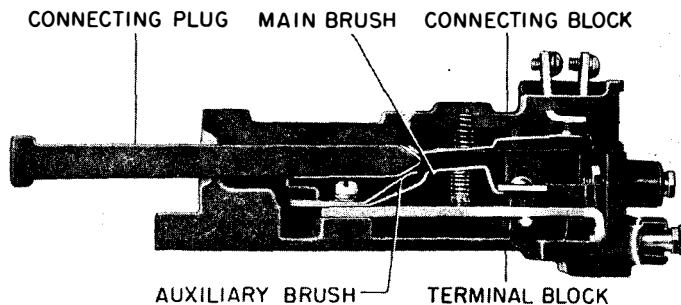

NOTE: AFTER ENGAGING AUXILIARY BRUSH, CONNECTING PLUG TRAVELS 1/4 INCH BEFORE ENGAGING THE MAIN BRUSH ON THE TERMINAL BLOCK.

Fig. 19 Cross Section of Drawout Case Showing Position of Auxiliary Brush

\* Denotes change since superseded issue.

## ADJUSTMENTS

### TARGET AND SEAL-IN UNIT

For trip coils operating on currents ranging from 0.2 up to 2.0 amperes at the minimum control voltage, set the target and seal-in tap screw in the 0.2-ampere tap.

For trip coils operating on currents ranging from 2 to 30 amperes at the minimum control voltage, place the tap plug in the 2-ampere tap.

The tap screw is the screw holding the right-hand stationary contact of the seal-in unit. To change the tap setting, first remove the connecting plug. Then, take a screw from the left-hand stationary contact and place it in the desired tap. Next, remove the screw from the other tap, and place it in the left-hand contact. This procedure is necessary to prevent the right-hand stationary contact from getting out of adjustment. Screws should not be in both taps at the same time.

### INDUCTION UNIT

#### CURRENT SETTING

\* The tap plug must not be removed without first withdrawing the connecting plug.

The current at which the contacts operate may be changed by changing the position of the tap plug in the tap block at the top of the relay. Screw the tap plug firmly into the tap marked for the desired current (below which the unit is not to operate).

When changing the current setting of the unit, remove the connecting plug to short circuit the current transformer secondary circuit. Next, screw the tap plug into tap marked for the desired current and then replace the connecting plug.

The pickup of the unit for any current tap is adjusted by means of a spring-adjusting ring. The ring may be turned by inserting a screw driver in the notches around the edge. By turning the ring, the operating current of the unit may be brought into agreement with the tap setting employed, if for some reason, this adjustment has been disturbed. This adjustment also permits any desired setting intermediate between the various tap settings to be obtained. The unit is adjusted at the factory to close its contacts from any time-dial position at a minimum current within five percent of the tap-plug setting. The unit resets at 90 per cent of the minimum closing value.

#### TIME SETTING

The setting of the time dial determines the length of time the unit requires to close its contacts when the current reaches a predetermined value. The contacts are just closed when the dial is set on 0. When the dial is set on 10, the disk must travel the maximum amount to close the contacts and therefore this setting gives the maximum time setting.

The primary adjustment for the time of operation of the unit is made by means of the time dial. However, further adjustment is obtained by moving the permanent magnet along its supporting shelf; moving the magnet toward the disk shaft decreases the time, while moving it away increases the time.

If selective action of two or more relays is required, determine the maximum possible short-circuit current of the line and then choose a time value for each relay that differs sufficiently to insure the proper sequence in the operation of the several circuit breakers. Allowance must be made for the time involved in opening each breaker after the relay contacts close. For this reason, unless the circuit time of operation is known with accuracy, there should be a difference of about 0.5 second (at the maximum current) between relays whose operation is to be selective.

#### EXAMPLE OF SETTING

The time and current settings of the overcurrent unit can be made easily and quickly. Each time value shown in Fig. 2 indicates the time required for the contacts to close with a particular time-dial setting when the current is a prescribed number of times the current-tap setting. In order to secure any of the particular time-current settings shown in Fig. 2, insert the removable plug in the proper tap receptacle and adjust the time-dial to the proper position. The following example illustrates the procedure in making a relay setting.

Assume a Type IAC relay is used in a circuit where the circuit breaker should trip on a sustained current of approximately 450 amperes; also, the breaker should trip in 1.9 seconds on a short-circuit current of 3750 amperes. Assume further that current transformers of 60/1 ratio are used.

The current tap setting is found by dividing the minimum primary tripping current by the current transformer ratio. In this case, 450 divided by 60 equals 7.5 amps. Since there is no 7.5-amp tap, the 8-amp. tap is used. To find the proper time-dial setting to give 1.9 seconds time delay at 3750 amperes, divide 3750 by the transformer ratio. This gives 62.5 amperes secondary current which is 7.8 times the 8-ampere setting. By referring to the time current curves (Fig. 2), it will be seen that 7.8 times the minimum operating current gives 1.9 seconds time delay when the relay is set slightly above the No. 6 time-dial setting.

The above results should be checked by means of an accurate timing device. Slight readjustment of the dial can be made until the desired time is obtained.

Aid in making the proper selection of relay settings may be obtained on application to the nearest Sales Office of the General Electric Company.

## CONTACT ADJUSTMENT

The contacts should have approximately 1/32 inch wipe. That is, the stationary contact should be deflected about 1/32 inch when the disk completes its travel. The contact wipe is adjusted by turning the screws in the contact brush which regulates the position of the brush, in relation to the brush stop. For relays with two circuit-closing contacts, the tips should be in the same vertical plane.

When the time dial is moved to a position where the contacts just close, the time-dial scale should indicate zero. If this is found incorrect, and the brushes are correctly adjusted, regulate the dial to read zero. This is done by changing the position of the arm attached to the shaft which is located below the time dial. Loosen the screw which clamps the arm to the shaft and turn the arm, relative to the shaft, until the contacts just make at the zero time-dial setting.

## INSTANTANEOUS UNIT

Select the current above which is desired to have the instantaneous unit operate and set the adjustable pole piece so that the top of hexagon head is even with the desired calibration on the scale. To raise or lower the pole piece loosen the locknut and turn it up or down and then tighten in position.

The contacts should be adjusted to make at about the same time and to have approximately 1/8" wipe. This adjustment can be made by loosening the screws holding the stationary contacts and moving the contacts up or down as required.

## A-C TRIPPING UNIT

The a-c tripping unit should not require any attention other than occasional cleaning of the contacts. However, if the adjustment should be lost, it may be restored as follows:

## OPERATION

Before the relay is put into service it should be given a check to determine that factory adjustments have not been disturbed. The time-dial will be set at zero before the relay leaves the factory. It is necessary to change this setting in order to open the relay contacts.

### 1. CONTACT ADJUSTMENT

With the unit de-energized, the movable contact should lie against the stationary contact with enough tension to always insure a good closed circuit. The movable contact brush should be free of any kinks. Also this contact brush should not touch the compound bushing supported from the top of the armature. The brass backing strip should be adjusted to allow a 1/16-inch contact gap with the contacts open. The compound bushing support should be adjusted to allow the back of the movable contact to just touch the brass backing strip when the armature operates to open the contacts. The outer edge of the compound bushing should be approximately 1/32 - inch from the inner edge of the stationary contact supporting post.

### 2. ARMATURE ADJUSTMENT

Loosen the two screws which hold the armature-assembly bracket to the bottom of the frame. Slide the bracket in or out, whichever is necessary, until the armature just touches the pole face of the upper core. In this position, the armature should be about 1/32 inch from the pole face of the lower core. Next, slide the bracket in until the armature leaf spring assumes a vertical position and is spaced clear of both armature and the vertical tip of the bracket. With this setting, the armature should be flush against the pole face of both cores, and should put enough pressure on the armature to always return it flush against the pole face of the lower core after each operation of the unit. This alignment is important as a slight gap between armature and pole face of the lower core after the unit operates may cause contacts to open momentarily, dropping the relay target when the circuit breaker is reclosed. Under these conditions, the momentary opening of the contacts is due to the shock of the armature being pulled in against the pole face when the lower coil is energized. Excessive pressure on the armature, caused by the bracket being pushed in too far, will result in too high a pickup or chattering of the movable contact during operation of the unit. Tighten the bracket screws securely after the proper adjustment has been obtained.

The pickup current should be checked on one or more of the taps and the time should be checked for one or more dial settings.

Recommended test connections for the above test are shown in Fig. 18.

## MAINTENANCE

The relays are adjusted at the factory and it is advisable not to disturb the adjustments. If, for any reason, they have been disturbed, the following points should be observed in restoring them:

### DISK AND BEARINGS

The lower jewel may be tested for cracks by

exploring its surface with the point of a fine needle. If it is necessary to replace the jewel a new pivot should be screwed into the bottom of the shaft at the same time. The jewel should be turned up until the disk is centered in the air gaps, after which it should be locked in this position by the set screw provided for this purpose.

### CONTACT CLEANING

For cleaning fine silver contacts, a flexible burnishing tool should be used. This consists of a flexible strip of metal with an etched roughened surface, resembling in effect a superfine file. The polishing action is so delicate that no scratches are left, yet corroded material will be removed rapidly and thoroughly. The flexibility of the tool insures the cleaning of the actual points of contact.

Fine silver contacts should not be cleaned with knives, files, or abrasive paper or cloth. Knives or files may leave scratches which increase arcing

and deterioration of the contacts. Abrasive paper or cloth may leave minute particles of insulating abrasive material in the contacts and thus prevent closing.

The burnishing tool described above can be obtained from the factory.

### PERIODIC TESTING

An operation test and inspection of the relay at least once every six months are recommended. Test connections are shown in Fig. 18.

### RENEWAL PARTS

It is recommended that sufficient quantities of renewal parts be carried in stock to enable the prompt replacement of any that are worn, broken, or damaged.

When ordering renewal parts, address the nearest Sales Office of the General Electric Com-

pany, specify quantity required, name of part wanted, and give complete nameplate data. If possible, give the General Electric Company requisition number on which the relay was furnished.

For a recommended parts list refer to Parts Bulletin number GEF-3883.

Fig. 20 (237C707)

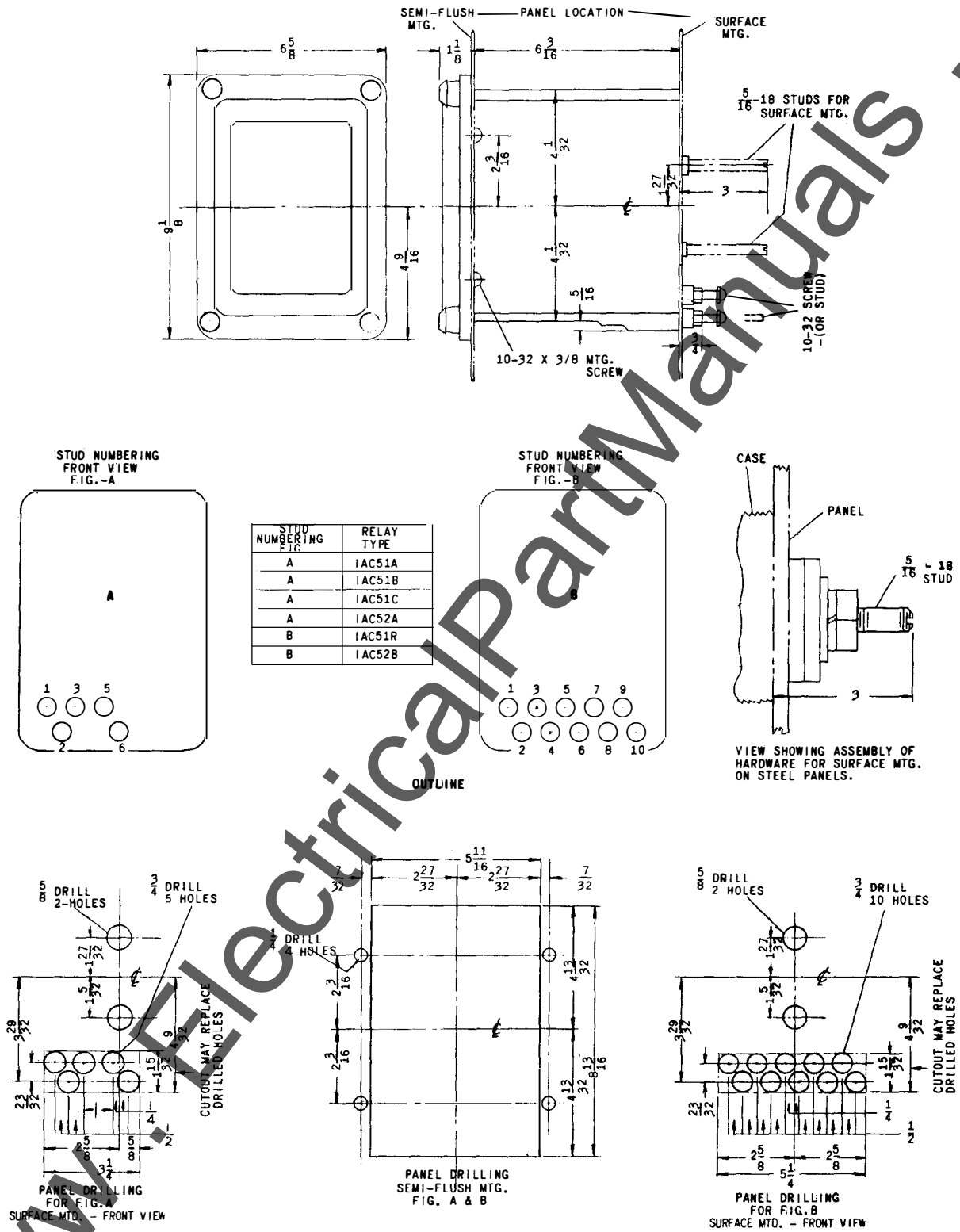

Fig. 20 Outline and Panel Drilling for the Type IAC51A, IAC51B, IAC51C, IAC51R, IAC52A and IAC52B Relays

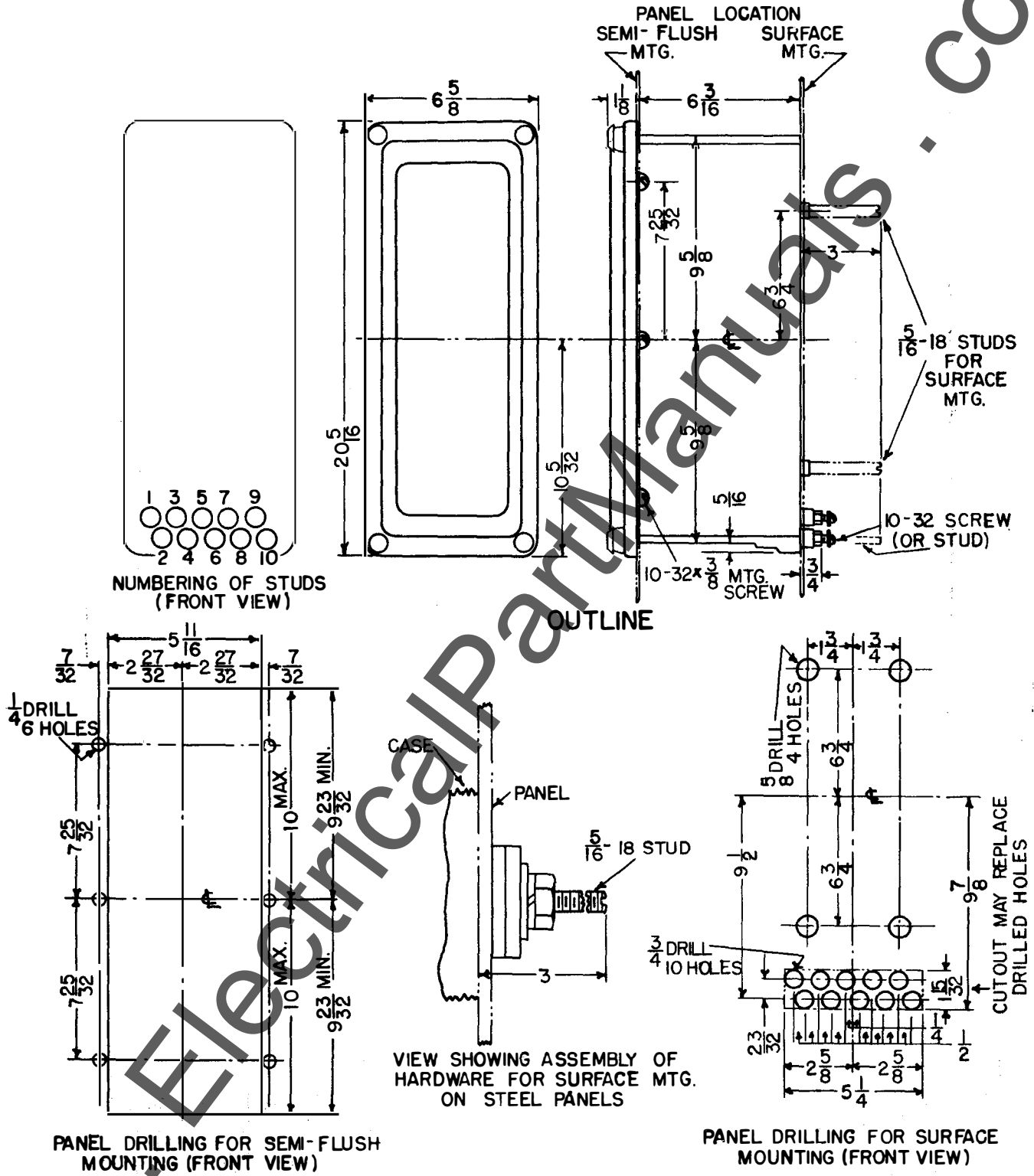

Fig. 21 Outline and Panel Drilling for the Type IAC51D Relay