

INSTRUCTIONS

Switchgear

AUXILIARY RELAYS

Hand Reset with Target

Type HEA

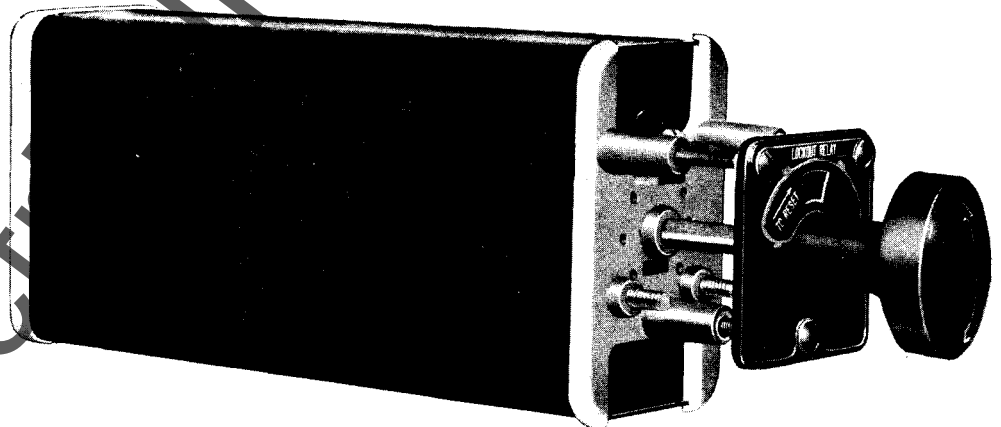

GENERAL  **ELECTRIC**

Auxiliary Relays Type HEA

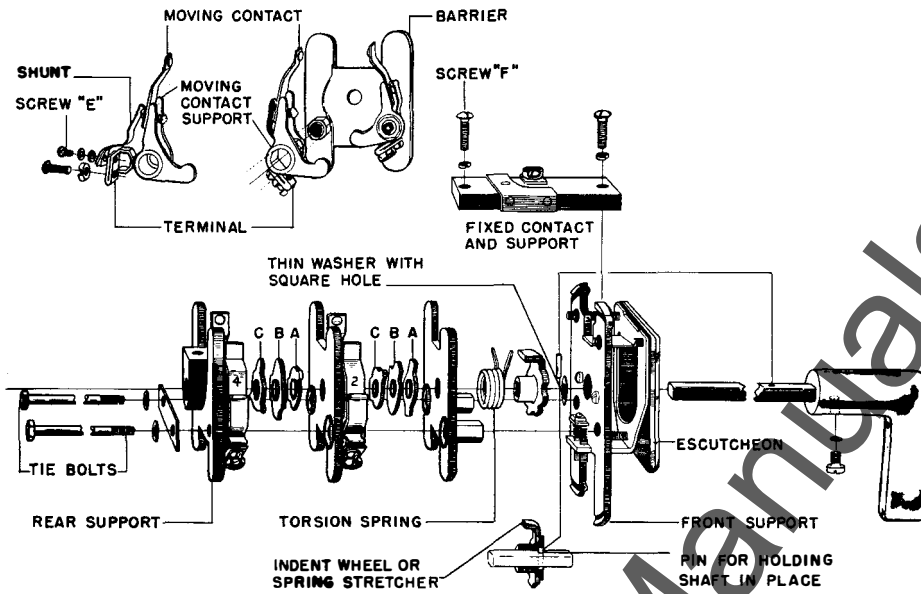

Fig. 1 Exploded View of Type SB-1 Switch

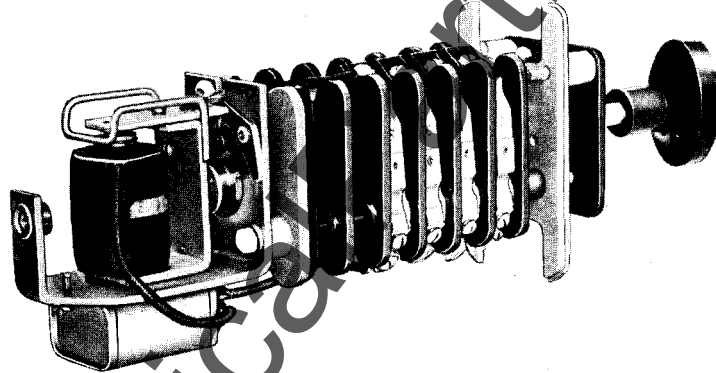

Fig. 2 6 Contact HEA Relay in Reset Position, With Cover Removed

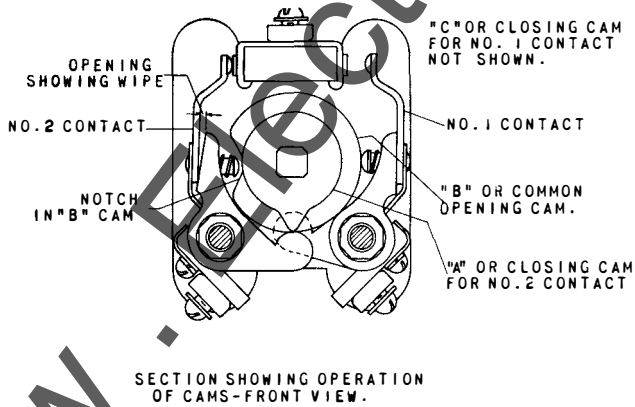

Fig. 3 Typical Section Showing Operation of Cams - Front View

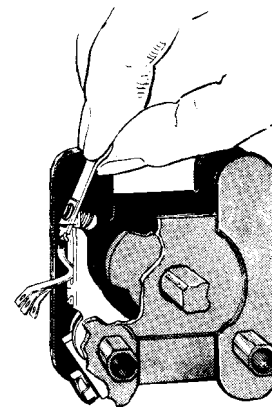

Fig. 4 Removing and Replacing Moving Contact

WWW.ElectricalManuals.com

AUXILIARY RELAYS - HAND RESET

TYPE HEA

INTRODUCTION

APPLICATION

The Type HEA multicontact, hand-reset auxiliary relays are applicable where it is desired that a number of operations be performed simultaneously. Some of the functions that can be performed by these relays are: trip the main circuit breaker of a system, operate an auxiliary breaker, open a neutral line breaker, trip main and auxiliary-field discharge breakers, and operate other relays which in turn perform various functions. Another important use of the Type HEA relay is in conjunction with differential relays which protect transformers, rotating apparatus, buses, etc. A typical application is illustrated in Fig. 6.

RECEIVING, HANDLING AND STORAGE

These relays, when not included as a part of a control panel will be shipped in cartons designed to protect them against damage. Immediately upon receipt of a relay, examine it for any damage sustained in transit. If injury or damage resulting from rough handling is evident, file a damage claim at once with the transportation company and promptly notify the nearest General Electric Apparatus Sales Office.

Reasonable care should be exercised in un-

CONTACT

The current-closing rating of the contacts is 50 amperes for voltages not exceeding 600 volts. The contacts have a current-carrying capacity of 20 amperes continuously or 50 amperes for one minute. The interrupting rating of the contacts varies with the inductance of the circuit. The values (in amperes) given in Table II, for d-c inductive circuits, are based on the average trip coil.

BURDENS

The burdens for the Type HEA relays are given in Table III.

packing the relay in order that none of the parts are injured or the adjustments disturbed.

If the relays are not to be installed immediately, they should be stored in their original cartons in a place that is free from moisture, dust and metallic chips. Foreign matter collected on the outside of the case may find its way inside when the cover is removed and cause trouble in the operation of the relay.

DESCRIPTION

These relays are built from parts of the Type SB-1 control and transfer switches (Figs. 1 and 2).

The operating shaft is held in the reset position by a positive latch. It is released through the action of the operating coil, in attracting a hinged-armature element. The time required to trip the relay, from the point of energization of the coil to the closing of the normally open contacts, is approximately 20 milliseconds (1-1/4 cycles on 60 cycle basis) slightly less for opening of the normally-closed contacts.

The mechanical target on the escutcheon plate assembly indicates the position of the relay. The

black target indicates the reset position and the yellow target, the tripped position. To reset the relay after being tripped, the handle is turned clockwise as indicated by the arrow on the escutcheon plate.

In addition to the 2, 6, 10 or 16 sets of contacts as provided, each relay is usually equipped with one normally-closed contact for opening the operating coil circuit, and one normally open contact that can be used for energizing a trip coil or operating an auxiliary relay. The 125 volt and higher rated d-c relays are supplied with a small capacitor, mounted under the coil which is used to reduce arcing of the coil circuit contacts.

TABLE I

TYPE	FIGURE	NO. OF CONTACTS	OVERLAPPING CONTACTS*
HEA11A	7	6 + 2 for Trip Coil	No
HEA11B	8	10 + 2 for Trip Coil	No
HEA11C	9	16 + 2 for Trip Coil	No
HEA11D	10	10 + 2 for Trip Coil	No
HEA11E	11	10 + 2 for Trip Coil	Yes
HEA11J	12	6 + 2 for Trip Coil	Yes
HEA11K	13	10 + 2 for Trip Coil	No
HEA11L	14	1 + 1 for Trip Coil	No
HEA11M	15	2 + 2 for Trip Coil	No

* All normally-closed contacts overlap all normally-open contacts.

These instructions do not purport to cover all details or variations in equipment nor to provide for every possible contingency to be met in connection with installation, operation or maintenance. Should further information be desired or should particular problems arise which are not covered sufficiently for the purchaser's purposes, the matter should be referred to the General Electric Company.

TABLE II

Circuit Volts	Non-Inductive Circuit			Inductive Circuit		
	Number of Contacts			Number of Contacts		
	1	2 in series	4 in series	1	2 in series	4 in series
24 d-c	6.0	30.0		4.0	20.00	30.0
48 d-c	5.0	25.0	40.0	3.0	15.00	25.0
125 d-c	2.5	11.0	25.0	2.0	6.25	9.5
250 d-c	0.75	2.0	8.0	0.7	1.75	6.5
600 d-c	0.25	0.45	1.35	0.15	0.35	1.25
115 a-c	40.00	50.0		24.0	50.0	
220 a-c	25.00	50.0		12.0	25.0	40.0
440 a-c	12.00	25.0		5.0	12.0	20.0
550 a-c	6.00	12.0		4.0	10.0	15.0

TABLE III

Intermittent Rating	Freq.	Resistance ohms 25 deg. C.	A-C Inrush Current Amps.	Rating of Protective Relay Target Coils in Amps.
12	d-c	0.382		2.0
24	d-c	1.60		2.0
32	d-c	2.86		2.0
48	d-c	6.70		2.0
60	d-c	9.00		2.0
125	d-c	24.0		0.2
250	d-c	133.		0.2
115	60 cyc.		25	2.0
230	60 cyc.		14	2.0
230	25 cyc.		2.88	0.2

The Type HEA11K relay is similar to the Type HEA11B relay except that it doesn't have a cover and is provided with a small front support mounted in an explosion-proof housing.

The Type HEA11D relay is similar to the Type HEA11B relay except that the two contacts for the trip coil are both open when the relay is reset.

INSTALLATION

LOCATION

The location should be clean and dry, free from dust and excessive vibration, and well lighted to facilitate inspection and testing.

MOUNTING

The relay should be mounted on a vertical surface. The relay may be mounted on panels, having thickness of 2 inches, 1 1/2 inches, 1 inch, or 5/32 inch. The shaft has tapped holes provided to secure the handle to it, the holes being properly located to accommodate the various panel thicknesses. For a 5/32 inch panel mounting, the shaft must

be shortened by cutting through the hole used for one inch panels. For intermediate thicknesses of panels, spacers are furnished to fill the excess space between the front support and panel. Two sets of mounting screws are provided for securing the relay to any of the above mentioned panel sizes.

The outline and panel drilling diagrams for the various types of HEA relays are shown in Figs. 7 to 15.

CONNECTIONS

The internal connections for the various types of HEA relays are shown in Figs. 7 to 15.

Fig. 5 (362A646)

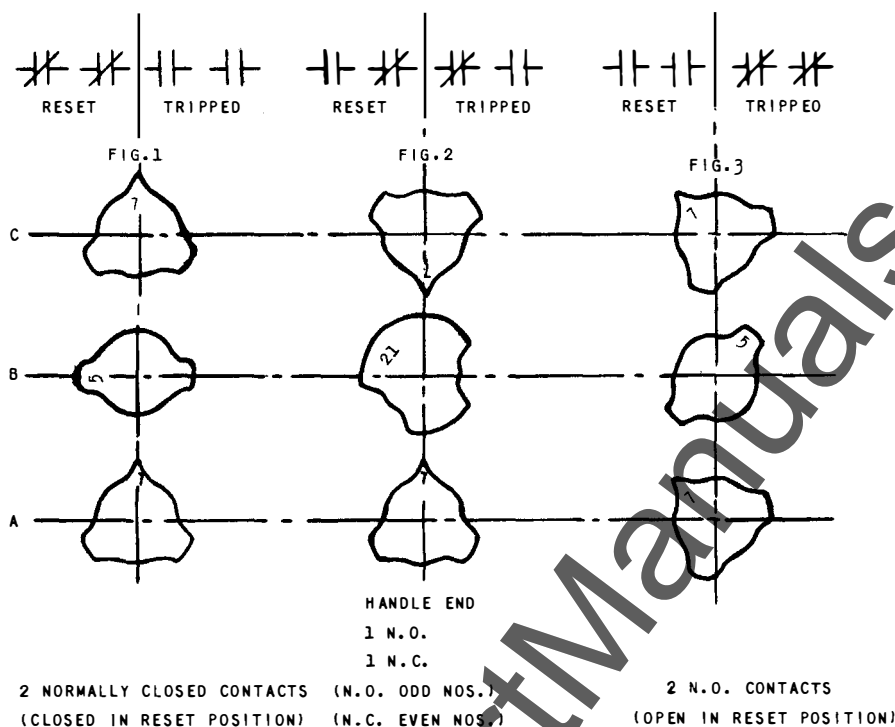

Fig. 5 Cam Arrangement (Front View)

MAINTENANCE

PERIODIC INSPECTION

At regular intervals, at least once every six months, the relays should be inspected for burning of the contacts, for broken shunts on the moving contacts and for contact wipe. If the shunts are broken or the contacts are badly pitted, they should be replaced as described under **INSTALLATION OF RENEWAL PARTS**. If the contacts are slightly pitted, it is advisable to follow the directions under **CONTACT CLEANING**.

Contacts have sufficient wipe as long as there is an appreciable opening, with the contact closed, between the moving contact and the moving-contact support (see Fig. 3). If there is no opening, it indicates that the parts of the moving-contact support that bears on the cam or the cam itself has become worn and needs replacing. The relay must be removed from the panel for repairs.

INSTALLATION OF RENEWAL PARTS

To remove the moving contact, position the switch so that the contact is open. Remove screw E, (Fig. 1) which holds the shunt to the terminal. Press in, on the top of the contact, to release the torque at its lower end (Fig. 4) and pull the contact upward and off.

The moving contact has a shoe that is assembled between the contact spring and the contact. When assembling a new moving contact, the end of the moving contact support must be inserted between the shoe and the moving contact. Then the contact may be slid down into place and screw (E) replaced. When replacing screw (E) be sure the plain washer and lockwasher are replaced and be careful to avoid creasing the thin metal strips of the shunt. Operate the switch and observe whether the contacts meet squarely and simultaneously. The contacts can be adjusted by bending slightly with smooth faced pliers. After adjustment there should be an appreciable gap, with the contacts closed between the moving contact and the moving support.

Damage to a fixed contact requires replacement of the complete assembly of fixed contacts and support. Remove screws F (Fig. 1), change assemblies and replace screws. Check alignment of contacts.

When cams, barriers, moving-contact supports, etc., need to be replaced, the switch should be removed from the panel and disassembled on a bench.

DISASSEMBLY

Before disassembling the switch, secure a drawing showing the cam arrangement in all the

Auxiliary Relays Type HEA

stages of the switch. (Refer to Fig. 2). Turn the switch shaft to the switch position corresponding to the cam arrangement. This is the 12 o'clock position unless otherwise noted on the drawing. Remove the handle and fixed-contact support. Unscrew the tie bolts from the front support, but leave them in the switch. Stand the switch on the bench resting on the rear support and slip the front support off the shaft, being careful to hold the shaft in the switch so as not to pull it out of the cams in the rear stage. Slide the shaft out just enough to remove the pin, through the shaft, which rests in the counterbore in the indent wheel or spring stretcher. Push the shaft back into the switch and slip off the indent wheel and the thin washer that is assembled between the indent wheel and front support. Remove the first barrier to expose the cams for contacts 1 and 2.

The cams and barriers may now be removed until the damaged part is reached.

Caution: The parts of the last contact stage adjacent to the latch mechanism should preferably not be removed, as they are formed differently from the others in order to facilitate operation of series targets in the coil circuit, and therefore are not interchangeable.

When converting from two normally-open to two normally-closed contacts or vice versa, no new parts are required. The cams of the stage to be converted are removed and reassembled as described under ASSEMBLY. When converting from two normally-open or two normally-closed contacts to one normally-open and one normally-closed contacts, a new cam must be inserted to replace cam B, which has number 5 molded on it. The new cam B (K-6178519) has no number molded on it. The same A and C cams are used (see Fig. 5). When converting from one normally-open and one normally-closed contacts to two normally open or two normally-closed contacts, replace cam B (no number on it) with a new cam B (M-6015923 P5), number 5 is molded on it.

Note: The preceding description of contact conversion does not apply to relay types HEA11E and HEA11J. These relays are designed for overlap between the normally-open and normally-closed contacts. It is recommended that these relays be returned to the factory if contact conversion is necessary.

It is recommended that sufficient quantities of renewal parts be carried in stock to enable the prompt replacement of any that are worn, broken, or damaged.

ASSEMBLY

Place the end of the shaft in the rear support so that the shaft stands vertically. With the shaft turned in the operation position (spring spreader toward top of switch), assemble the cams for each stage in the order C-B-A and in the positions shown in Fig. 1, depending on the contact arrangement desired for the individual stage. Assemble first, all the stages that are to have two normally-closed contacts; then the one stage (if any) that is to have one normally-open and one normally-closed contacts; and finally, all stages that are to have two normally-open contacts.

When the front barrier, which carries no contacts is in place, assemble the indent wheel (or spring spreader and torsion spring) with the counterbored end toward the front support. Pull the shaft out just enough to permit the locking pin to be inserted through the shaft back into the switch and slide the thin washer over the shaft. Slide the front support in place. Hold the stack of barriers together and turn the switch to the horizontal with the moving contacts pointed up. Before tightening the tie bolts be sure the barriers are all properly rested. The fixed contacts and support may not be assembled.

CONTACT CLEANING

For cleaning fine silver contacts, a flexible burnishing tool should be used. This consists of a flexible strip of metal with an etched roughened surface, resembling in effect a superfine file. The polishing action is so delicate that no scratches are left, yet corroded material will be removed rapidly and thoroughly. The flexibility of the tool insures the cleaning of the actual points of contact. Sometimes an ordinary file cannot reach the actual points of contact because of some obstruction from some other part of the relay.

Fine silver contacts should not be cleaned with knives, files, or abrasive paper or cloth. Knives or files may leave scratches which increase arcing and deterioration of the contacts. Abrasive paper or cloth may leave minute particles of insulating abrasive material in the contacts and thus prevent closing.

The burnishing tool described is included in the standard relay tool kit obtainable from the factory.

RENEWAL PARTS

When ordering renewal parts, address the nearest Sales Office of the General Electric Company, specifying the quantity required and describing the parts by catalogue numbers as shown in Renewal Parts Bulletin No. GEF-3325.

Fig. 6 (k-6174073)

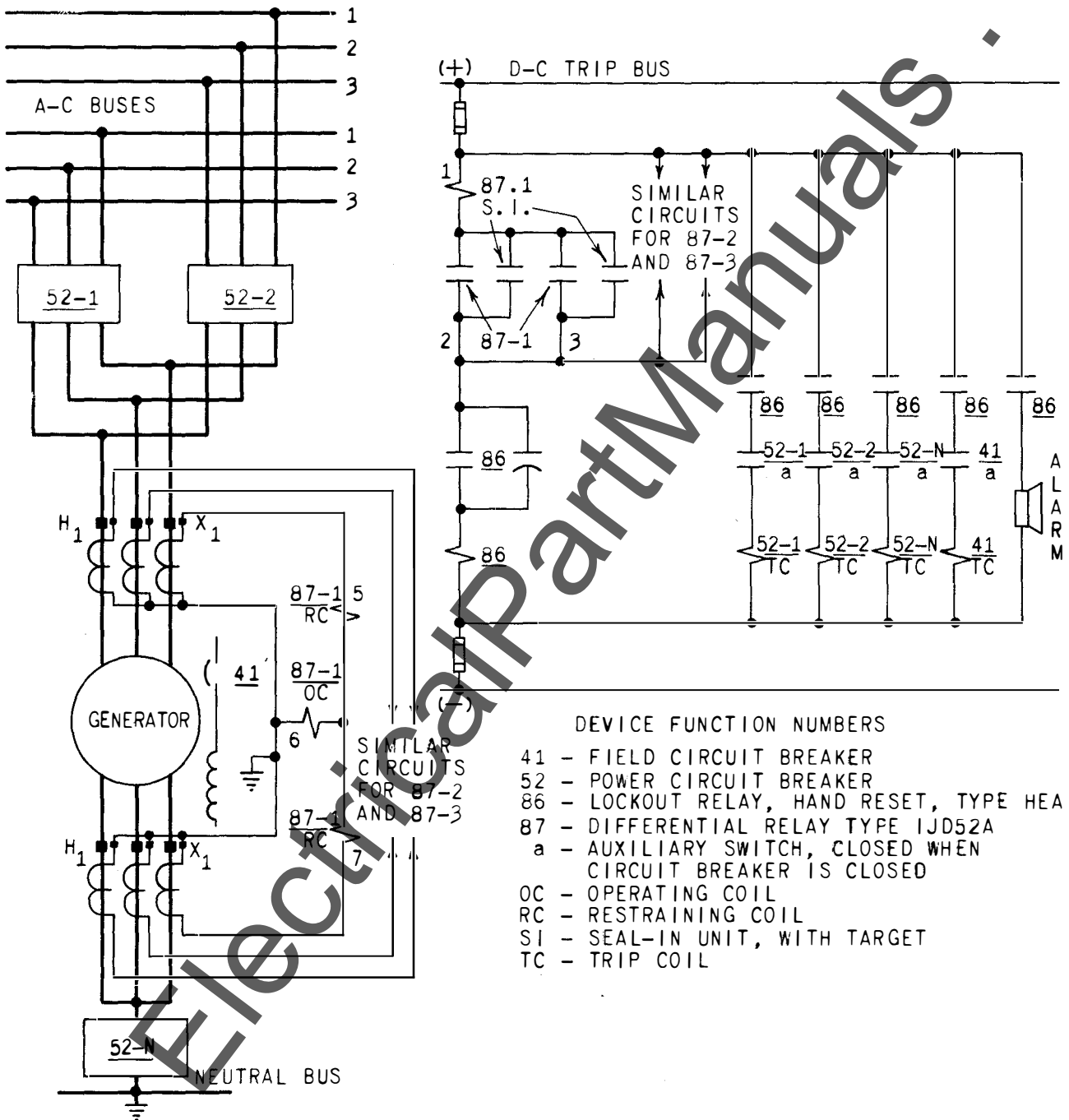

Fig. 6 Typical Application Of Type HEA Relays As Auxiliary Device In The Differential Protection Of A Generator

Auxiliary Relays Type HEA

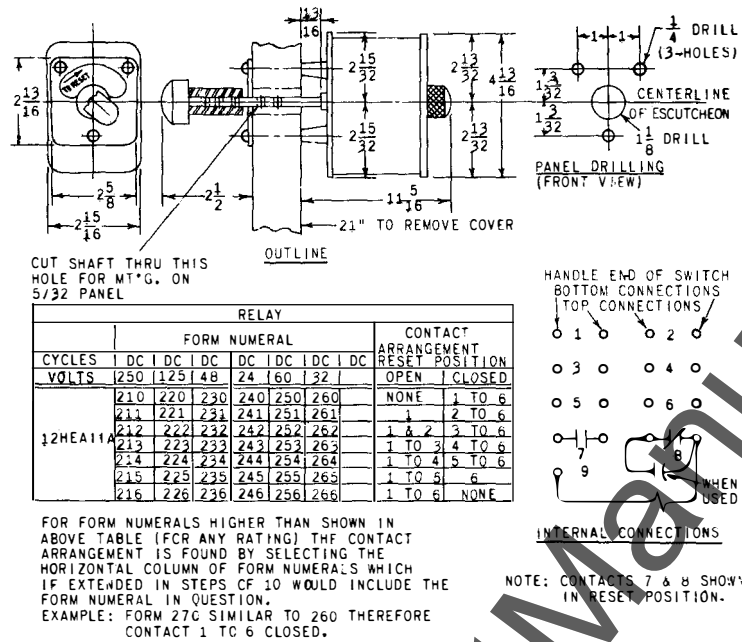

Fig. 7 Outline, Panel Drilling And Internal Connections For Type HEA11A Relay

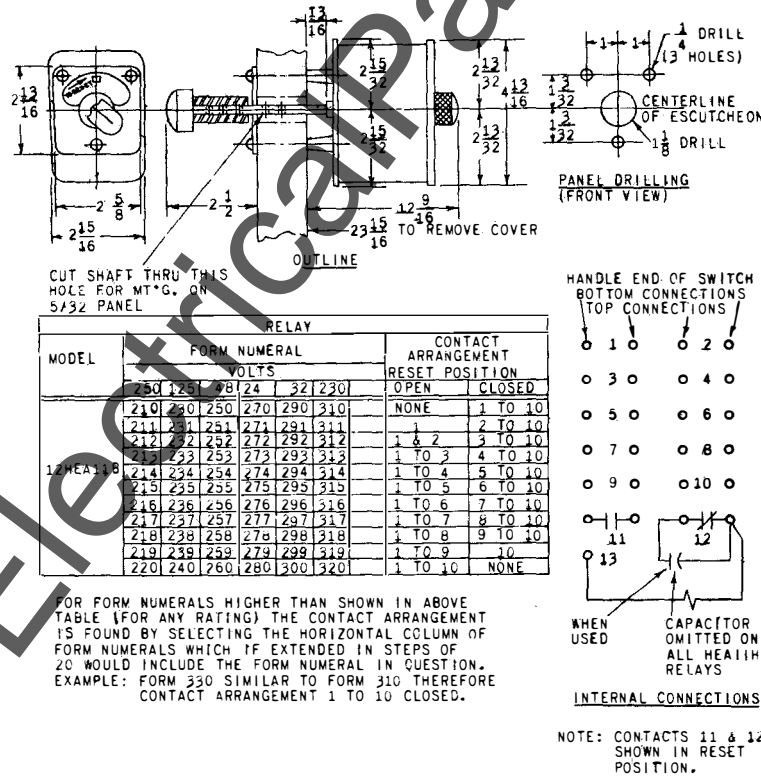

Fig. 8 Outline, Panel Drilling And Internal Connections For Type HEA11B Relay

Fig.7(K-6305878)

Fig.8(K-6305879)

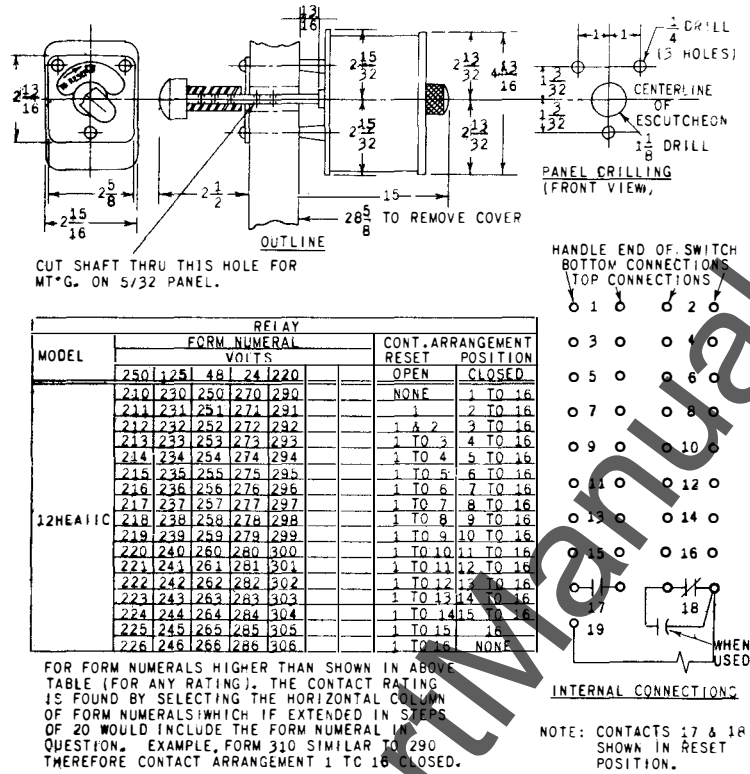

Fig. 9 Outline, Panel Drilling And Internal Connections For Type HEA11C Relay

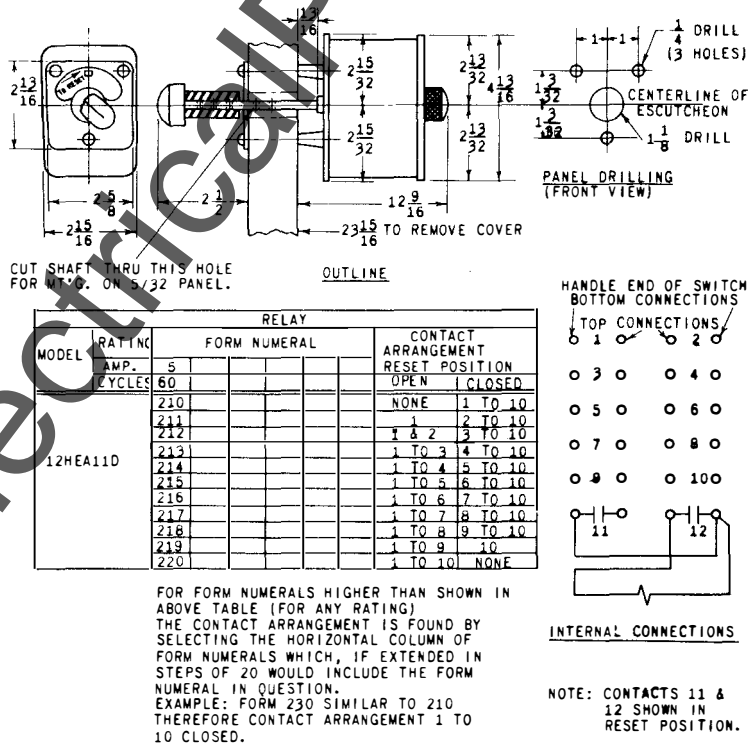

Fig. 10 Outline, Panel Drilling And Internal Connections For Type HEA11D Relay

Fig. 9 (K-6305880)

Fig. 10 (K-6305881)

Auxiliary Relays Type HEA

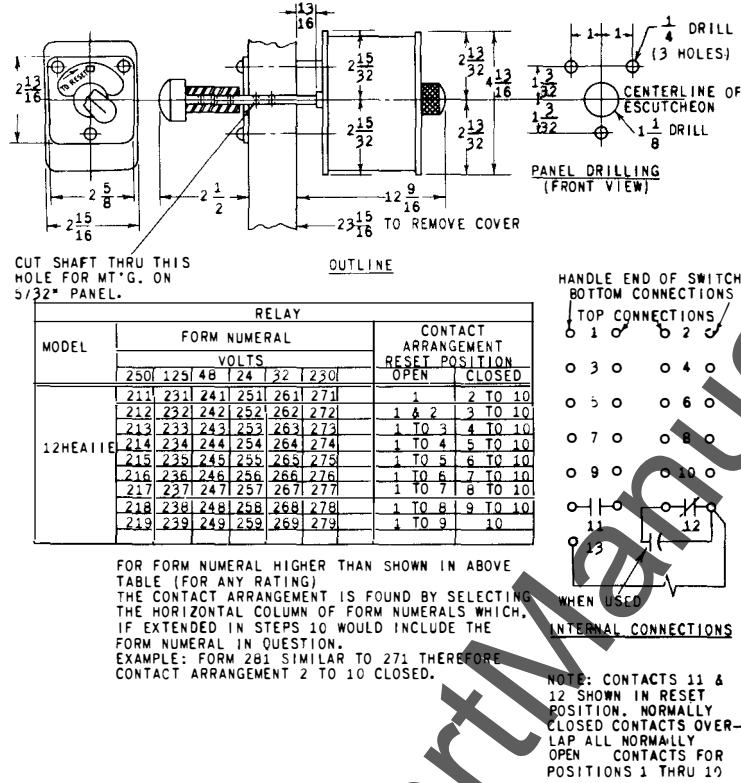

Fig. 11 Outline, Panel Drilling And Internal Connections For Type HEA11E Relay

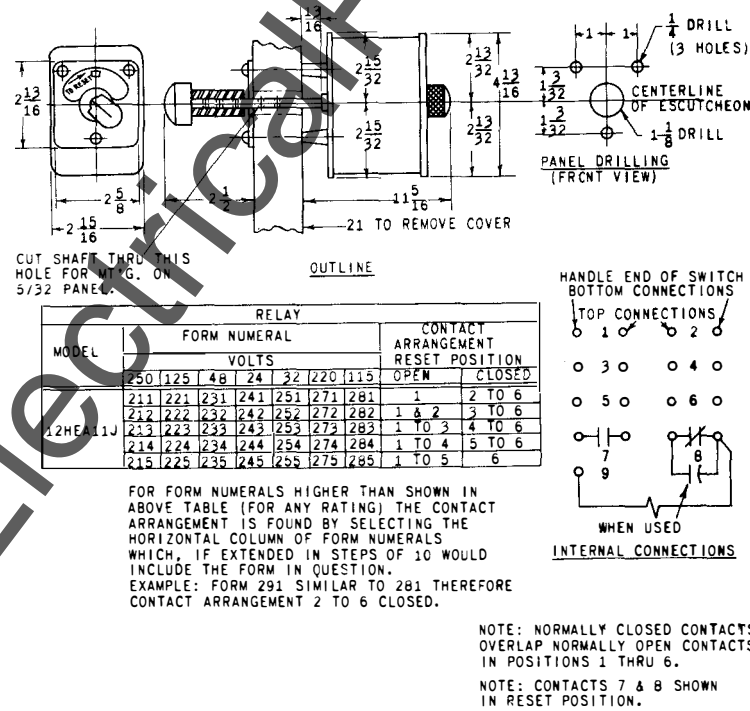

Fig. 12 Outline, Panel Drilling And Internal Connections For Type HEA11J Relay

Fig. 11(K-6305882)

Fig. 12(K-6305883)

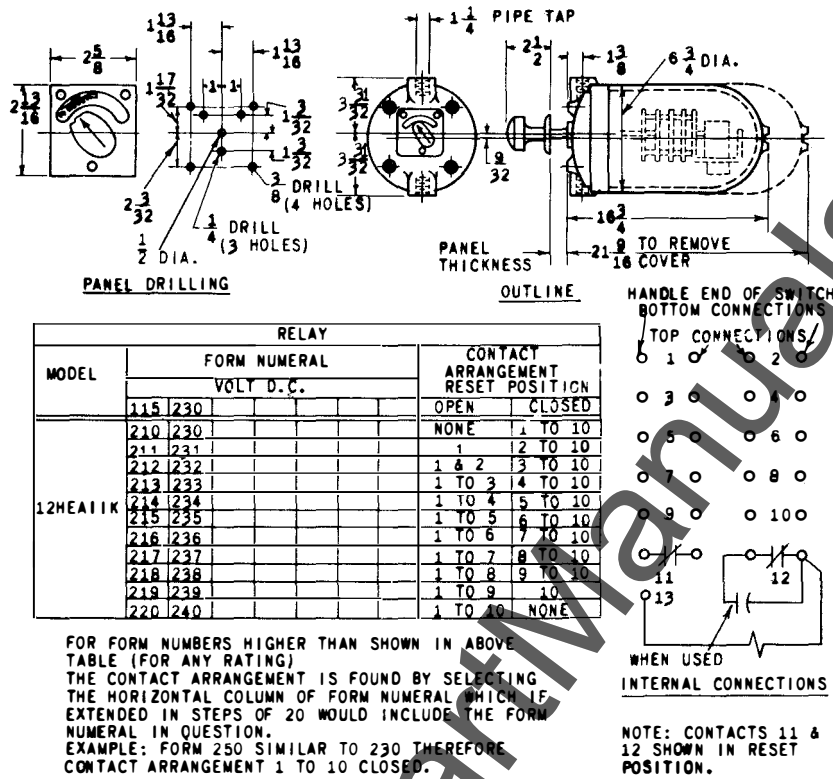

Fig. 13 Outline, Panel Drilling And Internal Connections For Type HEA11K Relay

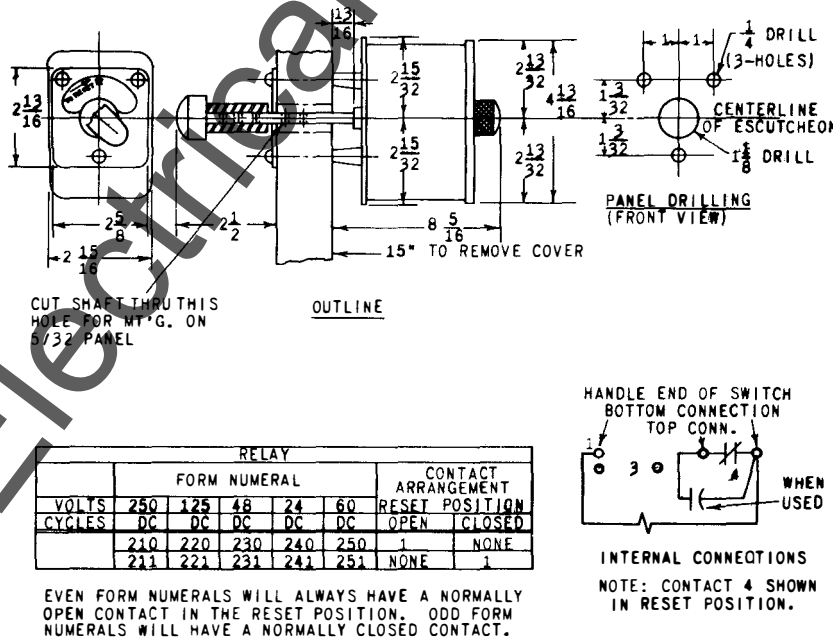
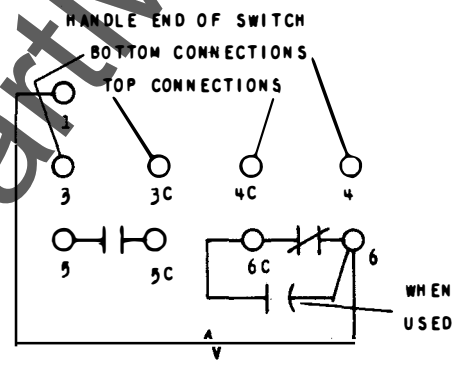
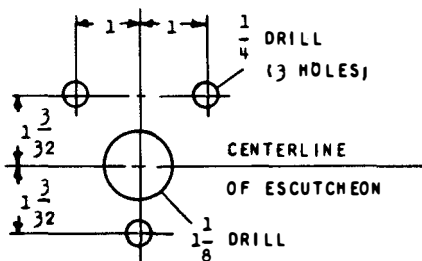
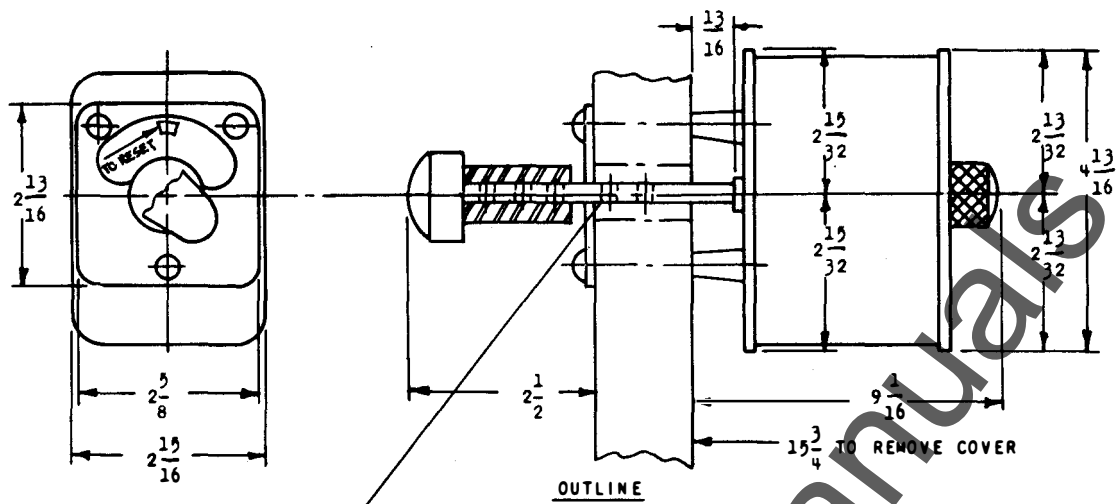

Fig. 14 Outline, Panel Drilling And Internal Connections For Type HEA11L Relay

Fig. 13(K-63058)

Fig. 14(K-6305885)

Auxiliary Relays Type HEA



NOTE-CONTACTS 5 & 6 SHOWN IN RESET POSITION

	RELAY					CONTACT ARRANGEMENT	
	FORM NUMERAL					RESET POSITION	
VOLTS	250	125	48	24	60	OPEN	CLOSED
CYCLES	DC	DC	DC	DC	DC	OPEN	CLOSED
	10	20	30	40	50	3 & 4	NONE
	11	21	31	41	51	3	4
	12	22	32	42	52	NONE	3 & 4

FOR FORM NUMBERS HIGHER THAN SHOWN IN ABOVE TABLE (FOR ANY RATING) THE CONTACT ARRANGEMENT IS FOUND BY SELECTING THE HORIZONTAL COLUMN OF FORM NUMERAL WHICH IF EXTENDED IN STEPS OF 10 WOULD INCLUDE THE FORM NUMERAL IN QUESTION.

EXAMPLE-FORM 60 SIMILAR TO 50 THEREFORE CONTACT ARRANGEMENT 3 & 4 OPEN.

Fig. 15 Outline, Panel Drilling And Internal Connections For Type HEAIIIM Relay