

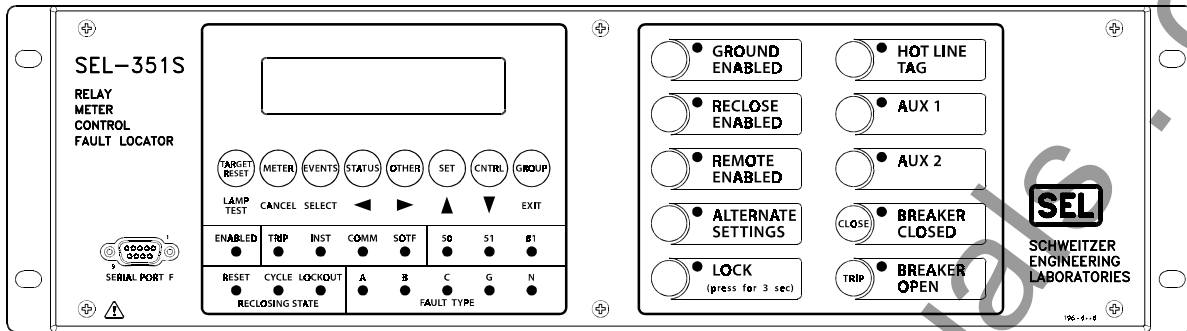

SEL-351S Protection and Breaker Control Relay



Optimize Distribution Protection with Breaker Control, Monitoring, and Fault Locating

Data Sheet

Major Features and Benefits

The SEL-351S Relay provides an exceptional package of protection, monitoring, control, and fault locating features. Protection includes overcurrent, under-/overvoltage, under-/overfrequency, phase, ground, neutral, and directional elements. Convenient operator controls minimize the need for external panel-mounted breaker control switches and meters. The operator interface, together with a suite of enhanced automation functions, provides attractive cost-savings in construction and operation of circuit breaker protection and control schemes. MIRRORED BITS™, load profile, power elements, voltage sag/swell/interruption recording, and expanded I/O are all available as optional functions.

- **Overcurrent Protection**
Protect lines and equipment using a sensitive and secure mix of phase, negative-sequence, residual-ground, and neutral-ground overcurrent elements, which can be made directional.
- **Monitoring and Metering**
Schedule breaker maintenance with interruption information. Alert personnel to substation battery voltage problems. Eliminate expensive meters with built-in metering functions.
- **Operator Controls and Reclosing**
Eliminate expensive control switches and wiring. Selectively reclose with synchronism and voltage checks.
- **Fault Locator**
Efficiently dispatch line crews to quickly isolate line problems and restore service faster.
- **Automation**
Sixteen elements are included for each of the following: Local Control, Local Display, Remote Control, and Latch Control.

SEL Schweitzer Engineering Laboratories

2350 NE Hopkins Court • Pullman, WA • 99163-5603 • USA

Phone: (509) 332-1890 • Fax: (509) 332-7990

E-mail: info@selinc.com • Internet: www.selinc.com



FUNCTIONAL OVERVIEW

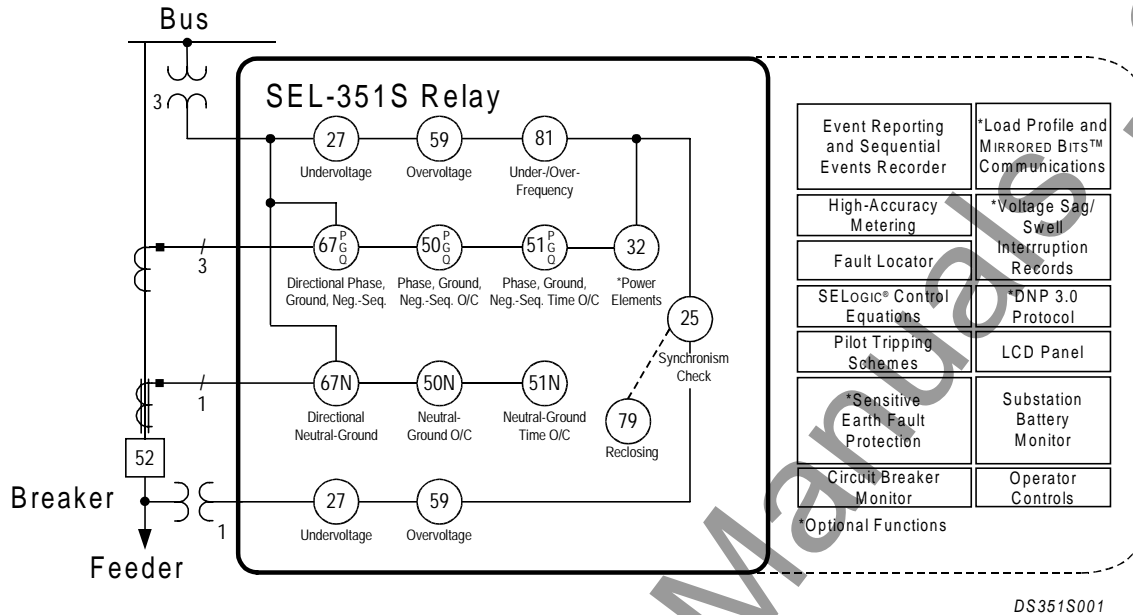

Figure 1: Functional Diagram

PROTECTION FEATURES

The SEL-351S Relay includes a robust set of phase, negative-sequence, residual, and neutral overcurrent elements. Each element type has six levels of instantaneous protection (four of these levels with definite-time functions). Each element type has two time-overcurrent elements (except negative-sequence that has one time-overcurrent element). Directional control is provided for each of these overcurrent elements.

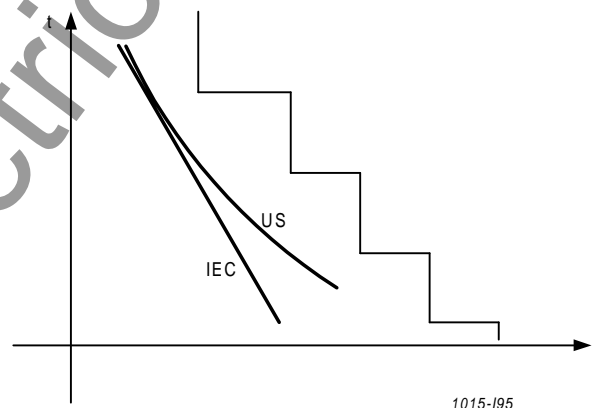

Figure 2: Instantaneous, Definite-Time, and Inverse Time-Overcurrent Characteristics

The following time-overcurrent curves are included:

- **US** - Moderately Inverse
Inverse
Very Inverse
Extremely Inverse
Short-Time Inverse
- **IEC** - Class A (Standard Inverse)
Class B (Very Inverse)
Class C (Extremely Inverse)
Long-Time Inverse
Short-Time Inverse

There are two reset characteristic choices for each time-overcurrent element. One choice resets the elements if current drops below pickup for at least 1 cycle. The other choice emulates electromechanical induction disc elements, where the reset time depends on the time dial setting, the percentage of disc travel, and the amount of current.

Overcurrent Elements for Phase Fault Detection

Phase and negative-sequence overcurrent elements detect phase faults. Negative-sequence current elements reject three-phase load to provide more sensitive coverage of phase-to-phase faults. The phase overcurrent elements are needed for three-phase faults where significant negative-sequence quantities are not produced.

On heavily-loaded feeders, the load encroachment logic adds security. This logic allows you to securely set the phase overcurrent elements below load to see end-of-line phase faults in heavily loaded feeder applications. This load encroachment logic uses positive-sequence load-in and load-out region elements to discriminate between load and fault conditions (Figure 3). When the load impedance (Z_1) resides in a load region, the phase overcurrent elements are blocked. As Figure 3 shows, when a phase fault occurs, Z_1 moves from a load region to the line angle, and the phase overcurrent elements are unblocked.

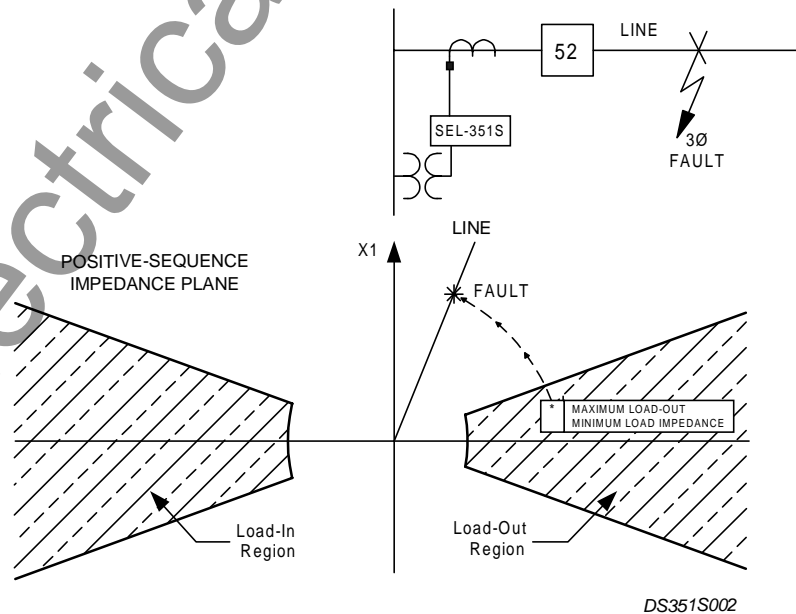

Figure 3: Load Encroachment Characteristics

The load encroachment logic also controls the phase directional element. Torque-controlling the phase overcurrent elements with the phase directional element then automatically includes load encroachment torque control. External input torque control of the phase overcurrent elements is also available.

Overcurrent Elements for Ground Fault Detection

Residual (I_G) and neutral (I_N) overcurrent elements detect ground faults. Increased security is achieved by control of these elements using optoisolated inputs or with the internal ground directional element. The ground directional element of this relay includes load-adaptive security logic for heavily or lightly loaded unbalanced feeder applications.

Sensitive Earth Fault (SEF) Element

A sensitive earth fault (SEF) element with time delay (up to 16,000 cycles) can be set as sensitive as 5 A secondary. Current channel IN ordered with a 0.05 A secondary nominal rating provides this sensitivity.

Directional Elements Increase Sensitivity and Security

Phase and ground directional elements are standard. An automatic setting mode can set all directional threshold settings for you, based on replica line impedance settings.

<u>Phase Directional Elements</u>	The phase directional elements provide directional control to the phase and negative-sequence overcurrent elements.
<u>Ground Directional Elements</u>	These elements provide directional control to the ground and neutral overcurrent elements.

The phase directional characteristics include positive-sequence and negative-sequence directional elements, which work together. The positive-sequence directional element includes memory which provides a reliable output for close-in, forward- or reverse-bolted, three-phase faults where each phase voltage is zero. The negative-sequence directional element uses the same patented principle proven in our SEL-321 Relay. This directional element can be applied in virtually any application regardless of the amount of negative-sequence voltage available at the relay location.

Ground directionality is provided by three directional elements working together:

- Negative-sequence voltage-polarized element.
- Zero-sequence voltage-polarized directional element.
- Zero-sequence current-polarized directional element.

Our patented *Best Choice Ground Directional*[™] Logic selects the best ground directional element for the system conditions. The *Best Choice Ground Directional* Logic scheme eliminates directional element settings. (You may override this automatic setting feature for special applications.)

Loss-of-Potential Logic Supervises Directional Elements

Voltage-polarized directional elements rely upon valid input voltages to make the correct decisions. The SEL-351S Relay includes loss-of-potential logic that detects one, two, or three

blown potential fuses and disables the directional elements. Optimally, for a loss-of-potential condition, forward-set overcurrent elements can be enabled to operate nondirectionally. This loss-of-potential logic is unique as it does not require settings and is applicable in all applications (patent pending).

Programmable Torque-Control Feature Handles Cold-Load Energization

When a feeder is reenergized following a prolonged outage, lost load diversity causes large phase currents (cold-load inrush). Phase overcurrent element misoperation during cold-load inrush can be avoided by programming cold-load block elements into the phase overcurrent element torque controls. One example of a cold-load block element is a time-delayed 52 status (long time-delay pickup and dropout timer with 52 as the input). An alternative is to automatically detect the long outage condition (breaker open) and temporarily switch to a setting group with higher phase overcurrent element pickup thresholds.

Voltage and Frequency Elements For Extra Protection and Control

Phase Under- and Overvoltage Elements

Phase undervoltage (device-27) and overvoltage (device-59) elements are included for creating protection and control schemes, such as:

- Torque-control for the overcurrent protection.
- Hot-bus (line), dead-bus (line) recloser control.
- Blown transformer high-side fuse detection logic.
- Trip/alarm or event report triggers for voltage sags and swells.
- An undervoltage (27) load shedding scheme. (Having both 27 and 81U load shedding schemes allows detection of system MVAR and MW deficient conditions.)
- Control schemes for capacitor banks.

The undervoltage and overvoltage elements associated with the V_S voltage channel are available for additional control and monitoring: hot-line/dead-line recloser control, ungrounded capacitor neutrals, ground fault detection on delta systems, generator neutral overvoltage, etc.

Sequence Voltage Elements

Independently set positive-, negative-, and zero-sequence voltage elements are included for protection and control. Applications include:

- Transformer bank single-phasing trip schemes.
- Delta-load back-feed detection scheme for dead-line recloser control.

Under- and Overfrequency Protection

Six levels of secure under- (81U) or overfrequency (81O) elements detect true frequency disturbances. Use the independently time-delayed output of these elements to shed load or trip local generation. Phase undervoltage supervision prevents undesired frequency element operation during faults.

The multiple under-/overfrequency levels allow you to implement an internal multistage frequency trip/restore scheme at each breaker location. This avoids the cost of wiring a complicated trip and control scheme from a separate frequency relay.

MONITORING AND METERING

Event Reporting and Sequential Events Recorder

Event Reports and Sequential Events Recorder (SER) features simplify post-fault analysis and help you improve your understanding of simple and complex protective scheme operations. In response to a user-selected trigger, the voltage, current, frequency, and element status information contained in each event report confirms relay, scheme, and system performance for every fault. Decide how much detail is necessary when you request an event report: 1/4-cycle or 1/16-cycle resolution, filtered, or raw analog data. The relay stores the most recent 30-cycle or 15-cycle long event reports in nonvolatile memory. The number of stored event reports ranges from 7 to 30 reports, depending on the specific relay model. Relay settings are always appended to the bottom of each event report.

Three analog data formats are available. The desired format is selected via command extensions to the event report command. These formats are:

- 1/4-cycle or 1/16-cycle resolution.
- Unfiltered or filtered analog.
- ASCII or Compressed ASCII.

The 1/4-cycle report is one-fourth the size of the 1/16-cycle report. Therefore, it is quicker to retrieve and analyze. This advantage is especially valuable following a major disturbance. The full 1/16-sample/cycle report can be retrieved when conditions warrant closer scrutiny.

The relay SER feature stores the latest 512 entries. Use this feature to gain a broad perspective at a glance. Items for triggering an SER entry include: input/output change of state occurrences, element pickup/dropout, recloser state changes, etc.

The IRIG-B time-code input synchronizes the SEL-351S Relay time to within ± 5 ms of the time-source input. A convenient source for this time code is the SEL-2020 or SEL-2030 Communications Processor (via Serial Port 2 on the SEL-351S Relay).

Demand Current Threshold Alarm

Overload and unbalanced current threshold alarms are available for phase, negative-sequence, neutral, and residual demand currents.

Two types of demand-measuring techniques are offered: thermal and rolling.

Select the demand ammeter time constant from 5 to 60 minutes.

Circuit Breaker Contact Wear Monitor

Circuit breakers experience mechanical and electrical wear every time they operate. Intelligent scheduling of breaker maintenance takes into account manufacturer's published data of contact wear versus interruption levels and operation count. With the breaker manufacturer's maintenance curve as input data, the SEL-351S breaker monitor feature compares this input data to the measured (unfiltered) ac current at the time of trip and the number of close-to-open operations.

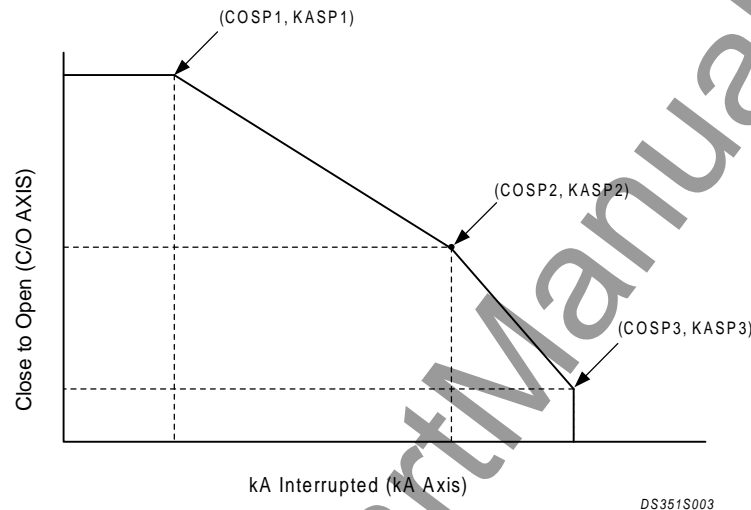

Figure 4: Breaker Contact Wear Curve and Settings

Every time the breaker trips, the measured current information is integrated. When the result of this integration exceeds the threshold set by the breaker wear curve (Figure 4), the relay can alarm via output contact, serial port, or front-panel display. With this kind of information, breaker maintenance is scheduled in a timely, economical fashion.

Substation Battery Monitor

The SEL-351S relay measures, tests, and reports the substation battery voltage presented to its power supply terminals. The relay includes two programmable threshold comparators and associated logic for alarm and control. For example, if the battery charger fails, the measured dc falls below a programmable threshold and operations personnel are then notified before the substation battery voltage falls to dangerous levels. Monitor these thresholds with the SEL-2020 or SEL-2030 Communications Processor and trigger messages, telephone calls, or other actions.

The measured dc voltage is reported in the METER display and the VDC column of the event report. Use the event report column data to see an oscillographic display of the battery voltage. You can see how much the substation battery voltage drops during trip, close, and other control operations.

Complete Metering Capabilities

Extensive and accurate metering capabilities are provided by the SEL-351S. $V_{A,B,C}$ and $I_{A,B,C}$ metering accuracies and power measurement accuracies are provided in the General Specifications section.

Metered quantities include phase voltages and currents (including demand), sequence voltages and currents, power, frequency, and energy (including demand) along with maximum/minimum logging of selected quantities. All metered quantities are reported in primary quantities (current in A primary and voltage in kV primary):

Currents	$I_{A,B,C,N}$	Input Currents
	I_G	Residual ground current ($I_G=3I_0=I_A + I_B + I_C$)
Voltages	$V_{A,B,C}$	Wye-connected voltage inputs
	V_S	Synchronism-check voltage input
Power	$MW_{A,B,C}$	Single-phase megawatts
	MW_{3P}	Three-phase megawatts
	$MVAR_{A,B,C}$	Single-phase megavars
	$MVAR_{3P}$	Three-phase megavars
Energy	$MWh_{A,B,C}$	Single-phase megawatt hours
	MWh_{3P}	Three-phase megawatt hours
	$MVARh_{A,B,C}$	Single-phase megavar hours
	$MVARh_{3P}$	Three-phase megavar hours
Power Factor	$PF_{A,B,C,3P}$	Single- and three-phase power factor; leading or lagging
Sequence	$I_1, 3I_2, 3I_0$	Positive-, negative-, and zero-sequence currents
Frequency	FREQ (Hz)	Instantaneous power system frequency (monitored on channel V_A)

If true three-phase voltage is not connected, the voltage ($V_{A,B,C}$), MW/MVAR, MWh/MVARh, and power factor metering values are not available.

OPERATOR CONTROLS AND RECLOSING

Operator Controls Eliminate Traditional Panel Control Switches

Ten conveniently sized operator controls are located on the relay front panel. The SER can track pushbutton operations if desired.

Operator control functions can be changed using SELOGIC[®] Control Equations. Some operator control pushbuttons might need to be relabeled. Remote control and indication can also be added to this local control and indication, using SELOGIC Control Equations (see Figure 6).

The following operator control descriptions are for factory-set logic.

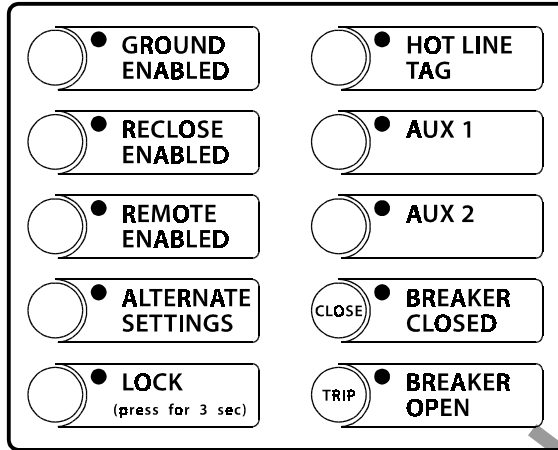

DS351S004

Figure 5: Operator Controls

Ground Enabled

When toggled on, the GROUND ENABLED operator control allows operation of the ground fault overcurrent protection functions. The corresponding LED illuminates to indicate the enabled state.

Reclose Enabled

When toggled on, the RECLOSE ENABLED operator control allows operation of the auto-reclosing scheme. The corresponding LED illuminates to indicate the enabled state. When LED is off, any trip will drive the relay to lockout.

Remote Enabled

When toggled on, the REMOTE ENABLED operator control allows operation of the SEL-351S controlled output functions by a remote operator (e.g., via contact input from SCADA, or through the serial port via modem or an SEL-2030 – see Figure 6). This function must first be enabled by user-applied settings.

Alternate Settings

The ALTERNATE SETTINGS operator control allows switching the active setting group between the main setting group (Group 1) and the alternate setting group (Group 2). The corresponding LED illuminates to indicate that the alternate setting group is active.

Lock

The LOCK operator control blocks selected functions. It must be depressed for at least three seconds to engage or disengage the lock function. While “locked in position,” the following operator controls cannot change state if pressed: GROUND ENABLED, RECLOSE ENABLED, REMOTE ENAGLED, ALTERNATE SETTINGS, AUX 1, and AUX 2. When the lock function is engaged, the CLOSE operator control cannot close the breaker, but the TRIP operator control can still open the breaker.

Hot Line Tag

When toggled on, the HOT LINE TAG operator control blocks closing and auto-reclosing of the circuit breaker. The HOT LINE TAG operator control overrides the RECLOSE ENABLED and CLOSE operator controls.

Aux 1, Aux 2

These user-defined operator controls enable/disable user-programmed auxiliary control functions.

Close, Trip

The CLOSE and TRIP operator controls are used to close and open the connected circuit breaker. They can be programmed with intentional time delays to support operational requirements for breaker-mounted relays. This allows the operator to press the CLOSE or TRIP pushbutton, then move to an alternate location before the breaker command is executed. The programmable delay ranges from 0 to 60 seconds.

The BREAKER CLOSED and BREAKER OPEN indicating LEDs reflect the breaker status in a fashion similar to panel-mounted indicating lamps.

Local and Remote Control

Under certain operating conditions, such as when performing distribution feeder switching, it is desirable to temporarily disable ground fault protection. This is accomplished in a variety of ways using the SELOGIC Control Equations with local and remote control. As shown in Figure 6, remote disable/enable control is achieved via contact input or the serial communications port. Local disable/enable control is handled by the operator control pushbutton. Indication of the ground relay operating status is provided both remotely and locally, via contact output, serial port, and local LED. The realization of remote control capabilities requires user programming of SELOGIC Control Equations.

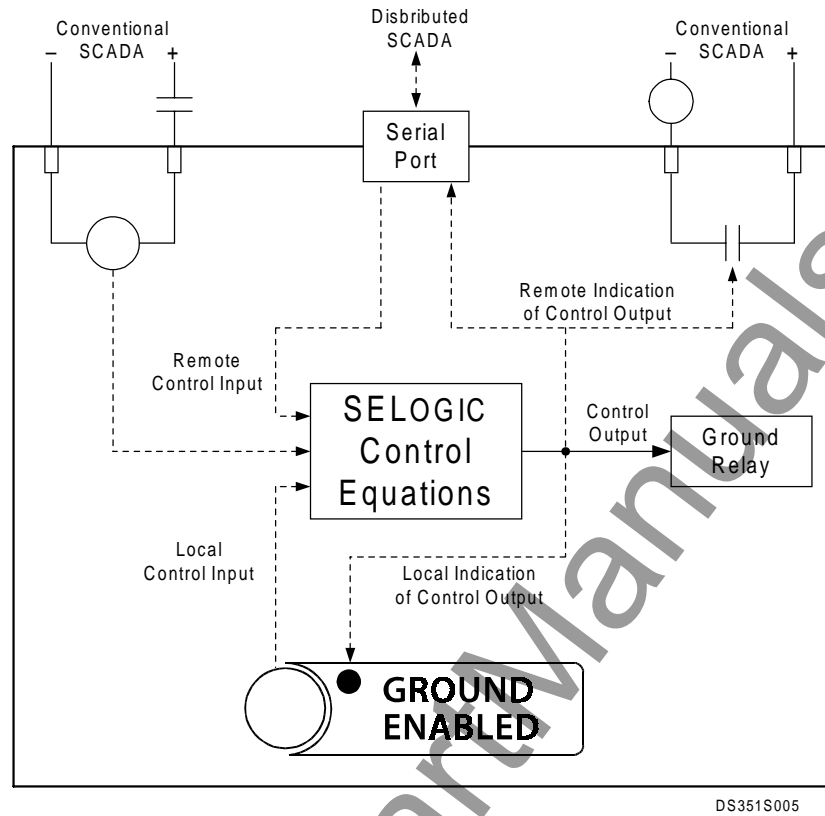

Figure 6: Local and Remote Control Using SELOGIC Control Equations

Four-Shot Recloser Handles Your Application Today and Tomorrow

Internal element status or external inputs can condition auto reclosing to match your practice:

- Reclose initiate (e.g., breaker opening, fault type, trip).
- Drive to lockout (e.g., input from manual or SCADA trip).
- Skip shot (e.g., skip instantaneous reclose for faults above a certain magnitude).
- Stall open interval timing (e.g., stall until line is dead).
- Close supervision (e.g., synch-check for the first reclose, check for dead line for the second reclose).
- Sequence coordination to keep the relay in step with down-stream reclosers.
- Close failure alarm.
- Separate reset times for reset timing from reclose cycle or lockout.

The recloser shot counter can control which protective elements are involved in each reclose interval. Applications include fuse and trip saving schemes. Front-panel LEDs track the recloser state: ♦Reset, Cycle, and Lockout.

FAULT LOCATOR

The SEL-351S relay provides an accurate estimate of fault location even during periods of substantial load flow. The fault locator uses fault type, replica line impedance settings, and fault conditions to develop an estimate of fault location without communications channels, special instrument transformers, or pre-fault information. This feature contributes to efficient dispatch of line crews and fast restoration of service.

AUTOMATION

Flexible Control Logic and Integration Features

Use the SEL-351S Relay control logic to:

- Replace traditional panel control switches.
- Eliminate RTU-to-relay wiring.
- Replace traditional latching relays.
- Replace traditional indicating panel lights.

Local control logic provides 16 logic points (local bits). Set, clear, or pulse the local bits with the front-panel pushbuttons and display (accessed via the CNTRL pushbutton). The local control provided by these local bits is separate from the operator controls shown in Figure 5. Program the local bits into your control scheme via the SELOGIC Control Equations. Use the local bits to trip test, enable/disable reclosing, trip/close the breaker, etc. Eliminate traditional panel control switches.

Remote control logic provides 16 logic points (remote bits). Set, clear, or pulse the remote bits via serial port command. Program the remote bits into your control scheme via the SELOGIC Control Equations. Use the remote bits for SCADA-type control operations: trip, close, settings group selection, ground relay enable/disable (see Figure 6), etc. Eliminate RTU-to-relay wiring.

Latch logic provides 16 latching logic points (latch bits). Program the latch set and latch reset conditions with SELOGIC Control Equations. Set or reset the latch bits via optoisolated inputs, remote bits, or local bits. Replace traditional latching relays for such functions as “hot line tagging.” The latch bits retain their state when the relay loses power.

Display logic provides 16 programmable messages for the front-panel display. Define custom messages (e.g., BREAKER OPEN, BREAKER CLOSED) to report power system or relay conditions. Control which messages are displayed via SELOGIC Control Equations; drive the LCD display via any logical point in the relay. Replace traditional indicating panel lights.

Serial Communications

- Three EIA-232 serial ports and one EIA-485 serial port. Each serial port operates independently of the other serial ports.
- Full access to event history, relay status, and meter information from the serial ports.
- Settings and group switching have password control.

- DNP Version 3.00 Level 2 protocol with point mapping (optional).
- Open communications protocols that are nonproprietary:
 - Simple ASCII
 - Plain-language commands for human and simple machine communications.
 - Use for metering, setting, self-test status, event reporting, and other functions.
 - Compressed ASCII
 - Comma-delimited ASCII data reports. Allows an external device to obtain relay data in a format which directly imports into a spreadsheet or database program. Data are checksum protected.
 - Extended Fast Meter
 - Binary protocol for machine-machine communications. Quickly updates the SEL-2020, RTU, other substation devices with metering information, relay element, input, and output statuses, time-tags, open and close commands, and summary event reports. Data are checksum protected.
 - Binary and ASCII protocol operates simultaneously over the same communications lines such that control operator metering information is not lost while a technician is transferring an event report.
 - LMD
 - Enables multiple SEL devices to share common communications (two character address setting range is 01 to 99). LMD is appropriate for low-cost, low-speed port switching applications where updating a real-time database is not a requirement.

The relay does not require special communications software. Dumb terminals, printing terminals, or a computer supplied with terminal emulation and a serial communications port is all that is required.

UNIQUE CAPABILITIES

Relay-to-Relay Digital Communications (MIRRORED BITS Technology)

The SEL patented MIRRORED BITS technology provides bidirectional relay-to-relay digital communications. MIRRORED BITS can operate independently on up to two EIA-232 serial ports on a single SEL-351S. With MIRRORED BITS operable on two serial ports, there is communication upstream and downstream from the SEL-351S site.

This bidirectional digital communication creates eight additional virtual outputs (transmitted MIRRORED BITS) and eight additional virtual inputs (received MIRRORED BITS) for each serial port operating in the MIRRORED BITS mode. These MIRRORED BITS can be used to transmit/receive information between upstream relays and downstream recloser control (e.g., SEL-351R) to enhance coordination and achieve faster tripping for downstream faults.

MIRRORED BITS technology also helps reduce total scheme operating time by eliminating the need to assert output contacts to transmit information.

Advanced SELOGIC Control Equations

Advanced SELOGIC Control Equations put relay logic in the hands of the relay application engineer. Assign the relay inputs to suit your application, logically combine selected relay elements for various control functions, and assign output relays to your logic functions.

Programming SELOGIC Control Equations consists of combining relay elements, inputs, and outputs with SELOGIC Control Equation operators. Any element in the Relay Word can be used in these equations.

The SELOGIC Control Equation operators include the following: OR, AND, invert, parentheses, rising and falling edges of element state changes.

In addition to Boolean-type logic, 16 general-purpose SELOGIC Control Equation timers eliminate the need for external timers for custom protection or control schemes. Each timer has independent time-delay pickup and dropout settings (six timers settable up to 999,999 cycles and ten timers settable up to 16,000 cycles). Program the input to a timer with any desired element (e.g., time qualify a voltage element). Assign the timer output to trip logic, reclose logic, or other control scheme logic.

Six Independent Setting Groups Increase Operation Flexibility

The relay stores six setting groups. Select the active setting group by contact input, command, or other programmable conditions. Use these setting groups to cover a wide range of protection and control contingencies. Selectable setting groups make the SEL-351S Relay ideal for applications requiring frequent setting changes and for adapting the protection to changing system conditions.

When you switch groups, you switch logic settings as well as relay element settings. Groups can be programmed for different operating conditions, such as feeder paralleling, station maintenance, seasonal operations, emergency contingencies, loading, source changes, and downstream relay setting changes.

STATUS AND TRIP TARGET LEDs

The SEL-351S relay includes 16 status and trip target LEDs on the front panel. As shipped from the factory, four of the LEDs are predefined and fixed in logic. The remaining 12 LEDs are factory set to follow the reclosing relay state and latch in on various trip conditions. This combination of targets is shown in Figure 7 and explained in Figure 8.

ENABLED	TRIP	INST	COMM	SOTF	50	51	81
●	●	●	●	●	●	●	●
RESET	CYCLE	LOCKOUT	A	B	C	G	N
●	●	●	●	●	●	●	●
RECLOSEING STATE				FAULT TYPE			

DS351S006

Figure 7: Status and Trip Target LEDs

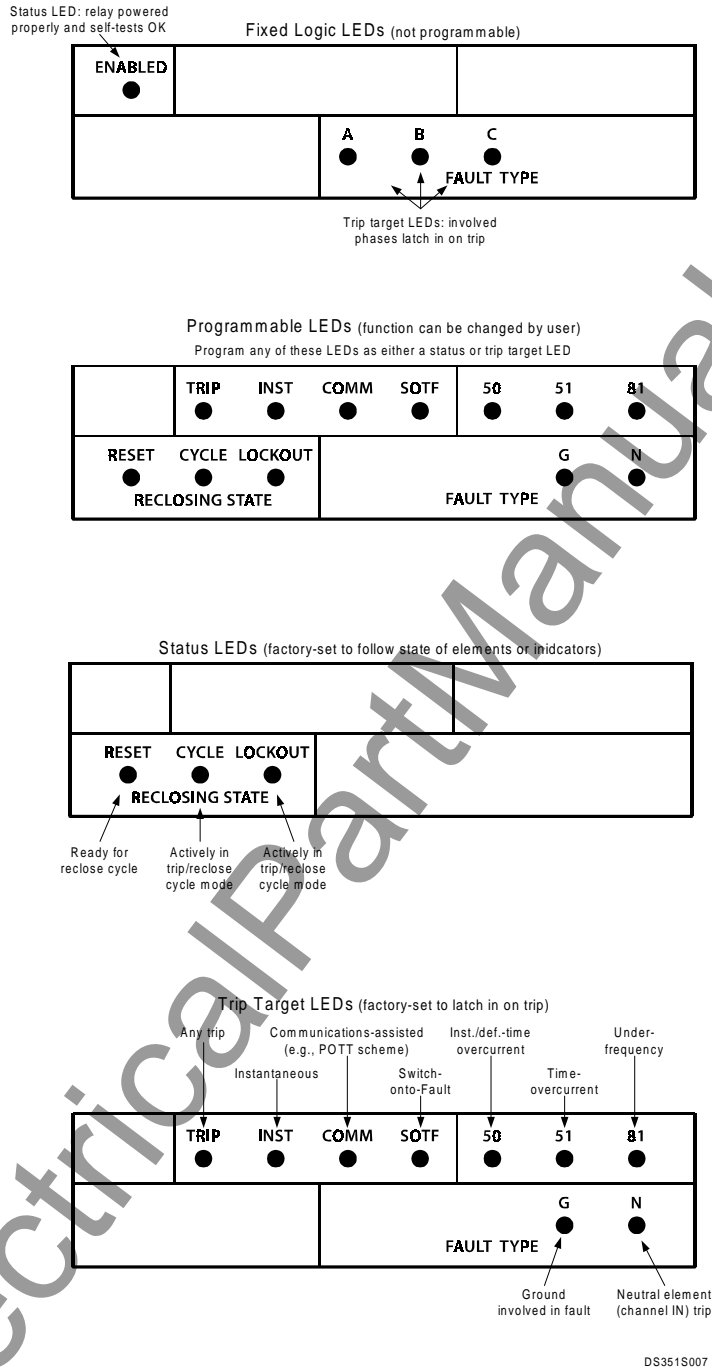

Figure 8: Breakdown of Fixed-Logic and Programmable LEDs

For unique or specific applications, reprogram LEDs as:

- ◆ Status LEDs (follow state of user-specified elements or indicators—e.g., dead line indication).
- Trip target LEDs (latch in on trip for user-specified condition—e.g., undervoltage trip).

Some front-panel relabeling of LEDs may also be needed for unique or specific applications.

WIRING DIAGRAM

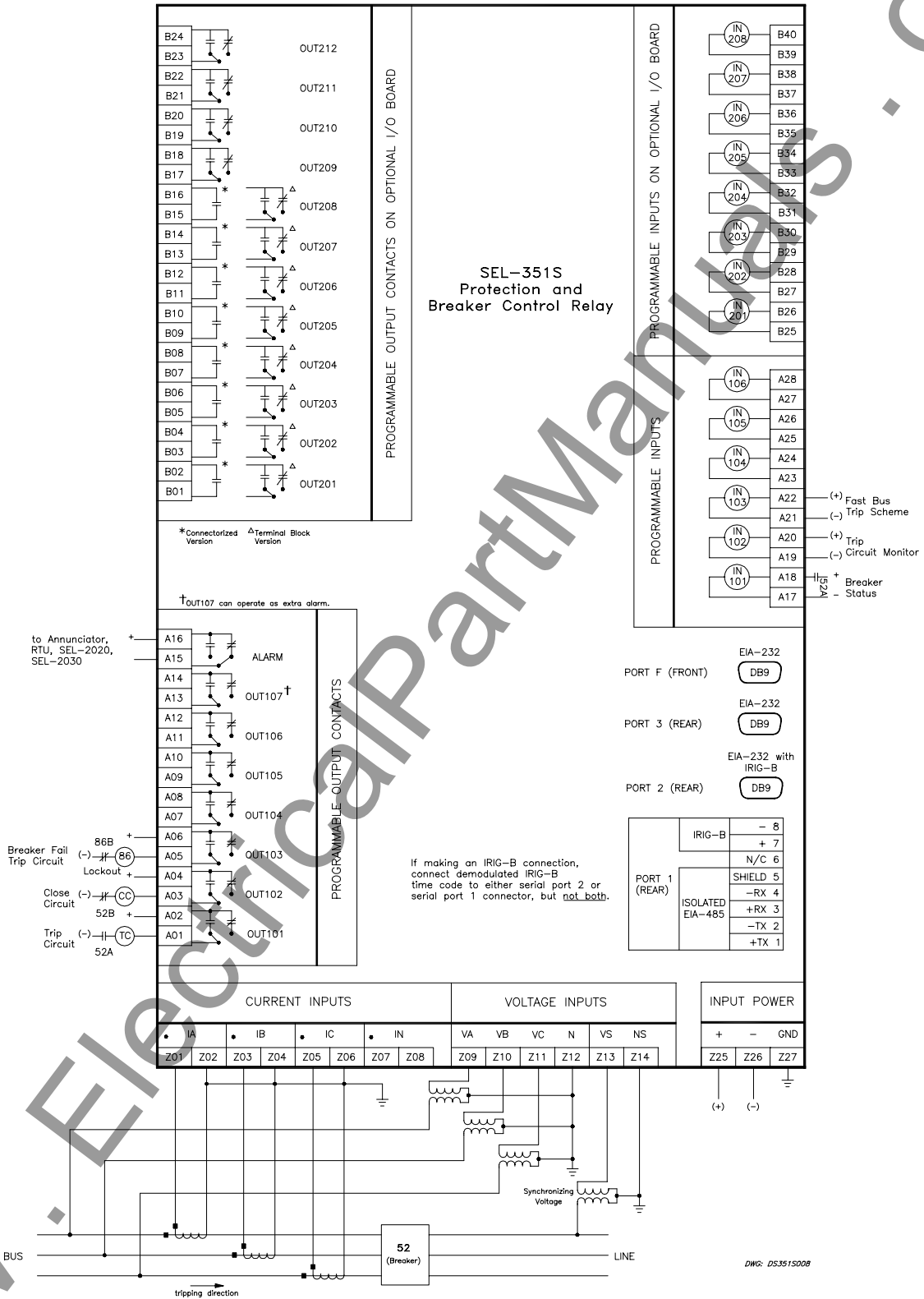
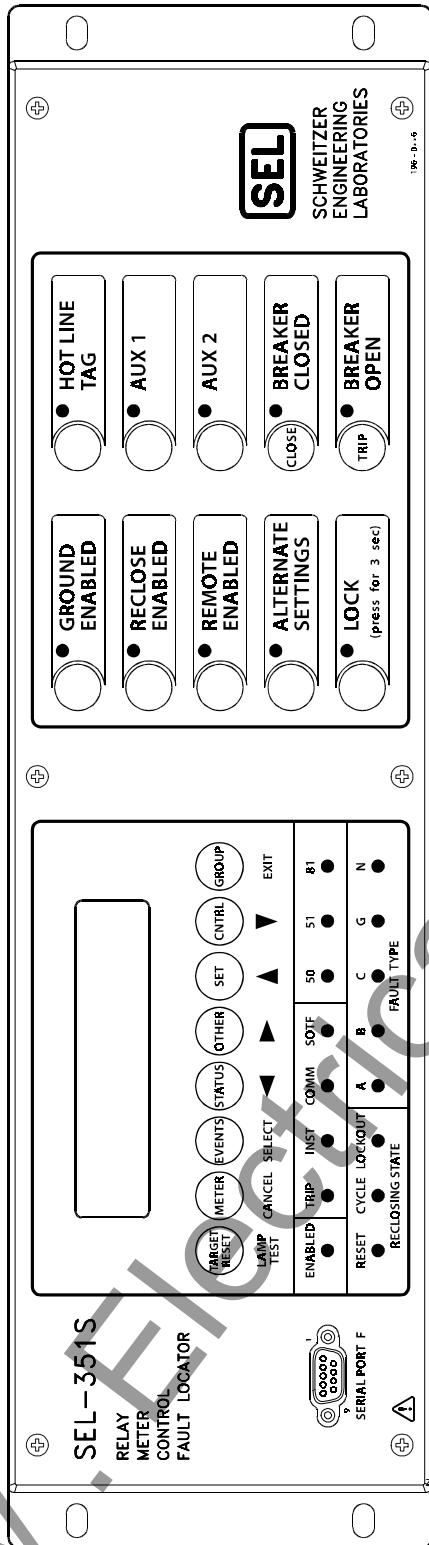
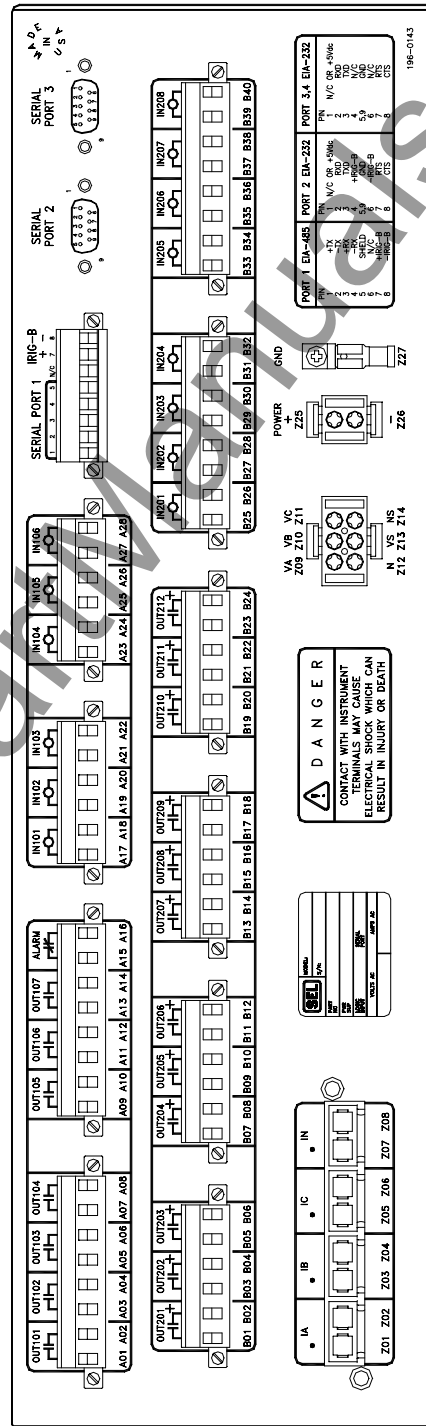

Figure 9: SEL-351S Wiring Diagram

MECHANICAL DIAGRAMS



11-004-A1



DWG. 11357

Figure 10: SEL-351S Relay Front- and Rear-Panel Drawings (Model 0351SxYH); Horizontal Rack Mount Example

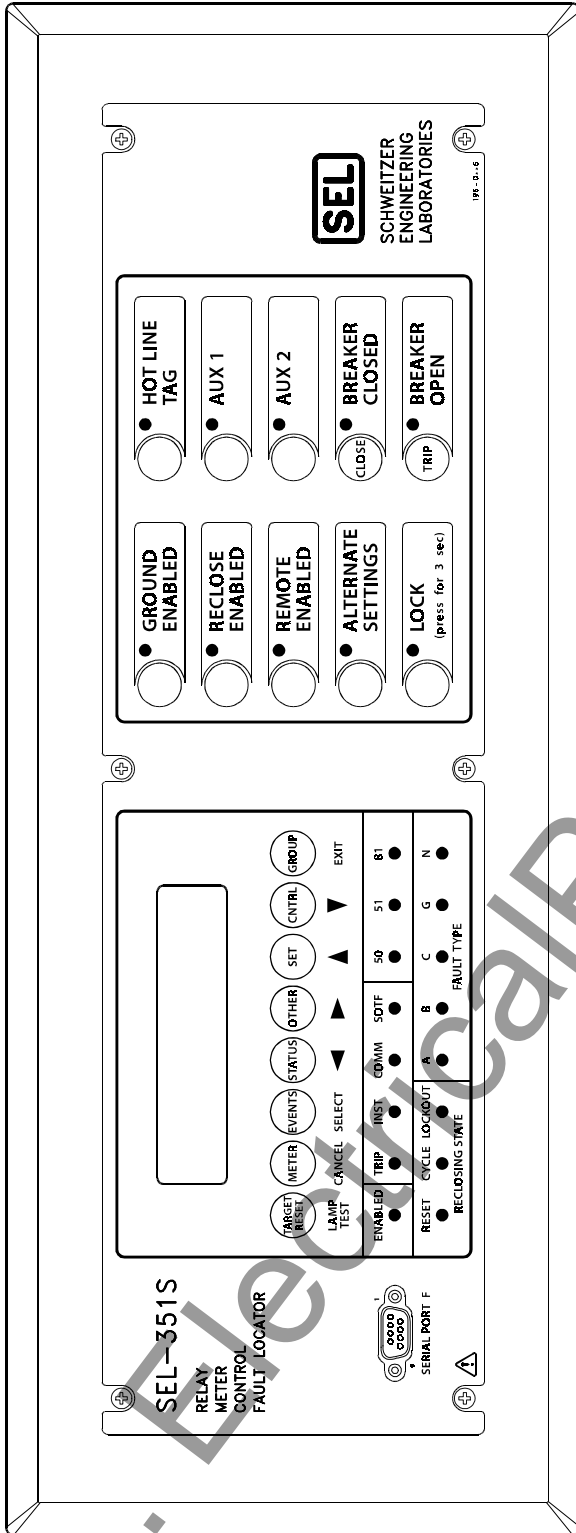

I1405.AI

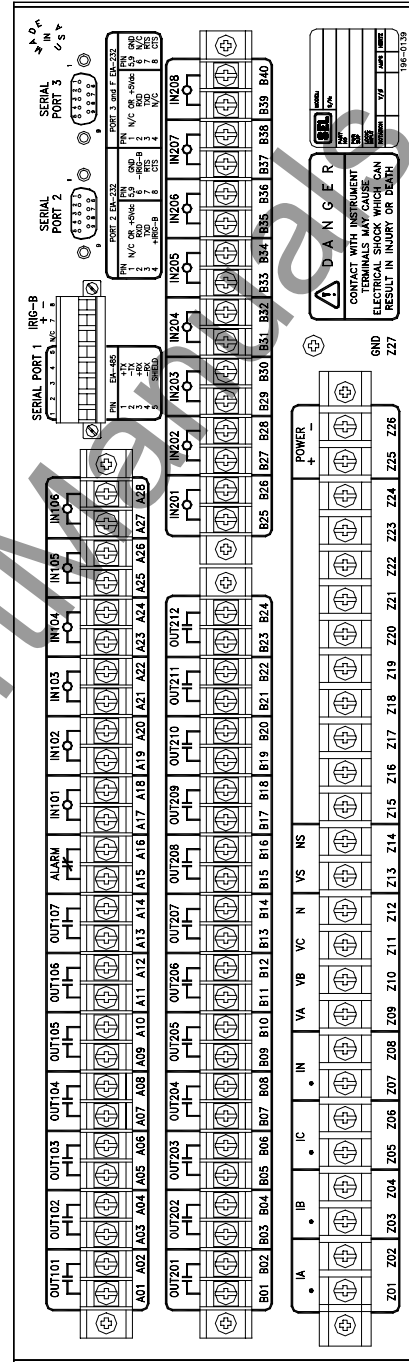

DWG. 11193

Figure 11: SEL-351S Relay Front- and Rear-Panel Drawings (Model 0351Sx13); Horizontal Panel Mount Example

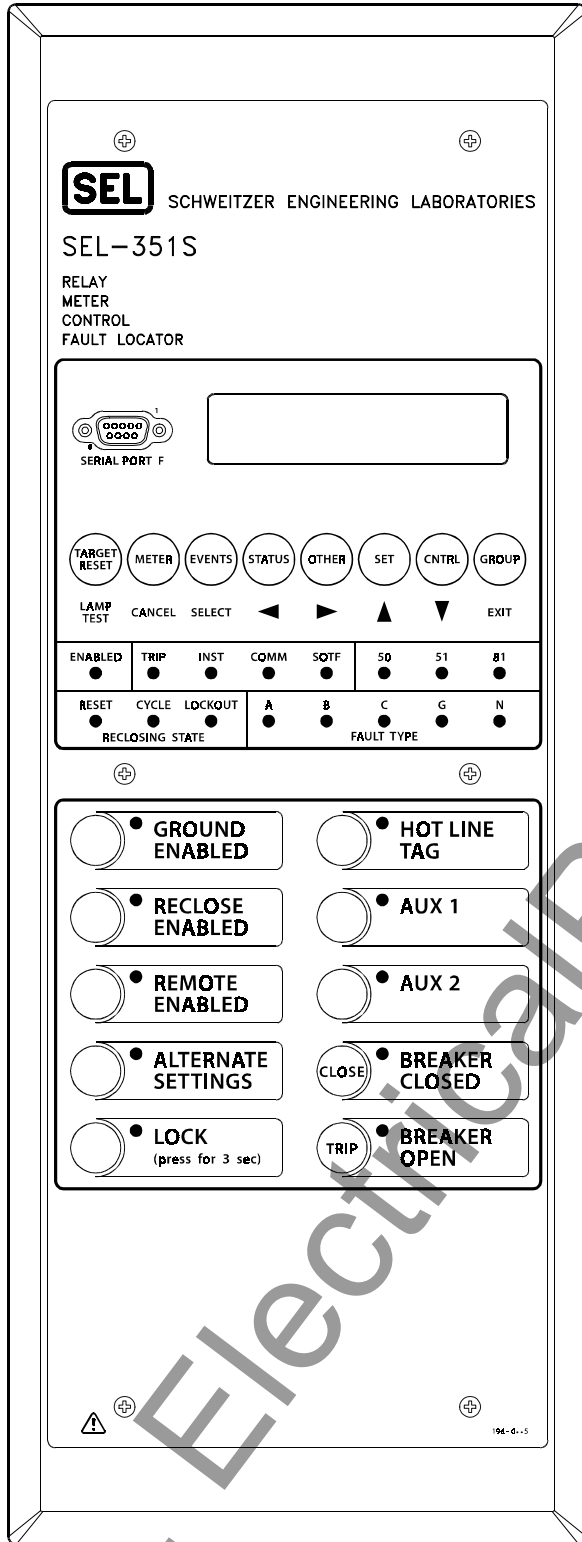

I1406.AI

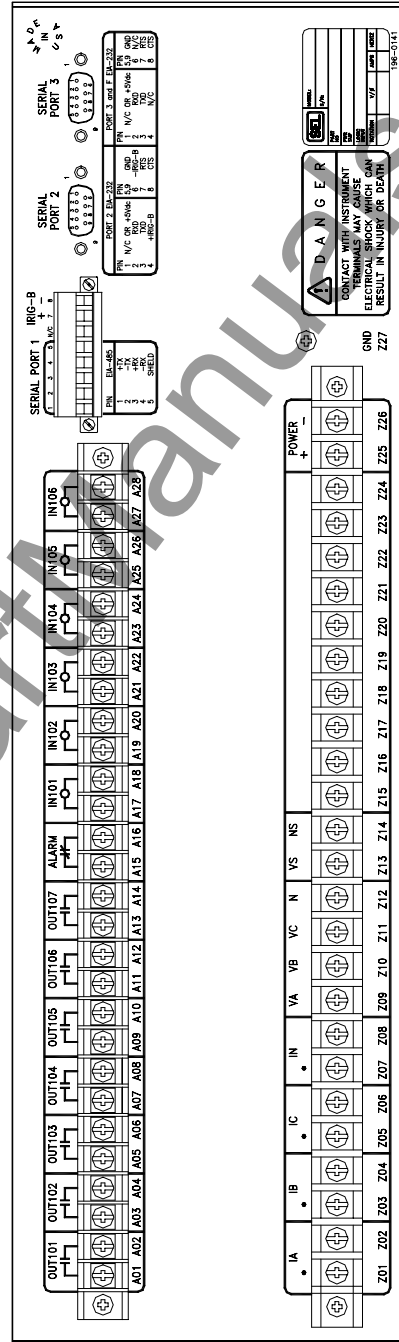

DWG. 11321

Figure 12: SEL-351S Relay Front- and Rear-Panel Drawings (Model 0351SxY4); Vertical Panel Mount Example

All three mounting styles can be ordered with terminal block, plug-in connectors, or with extra I/O. For model options, contact your local SEL sales representative.

RELAY MOUNTING

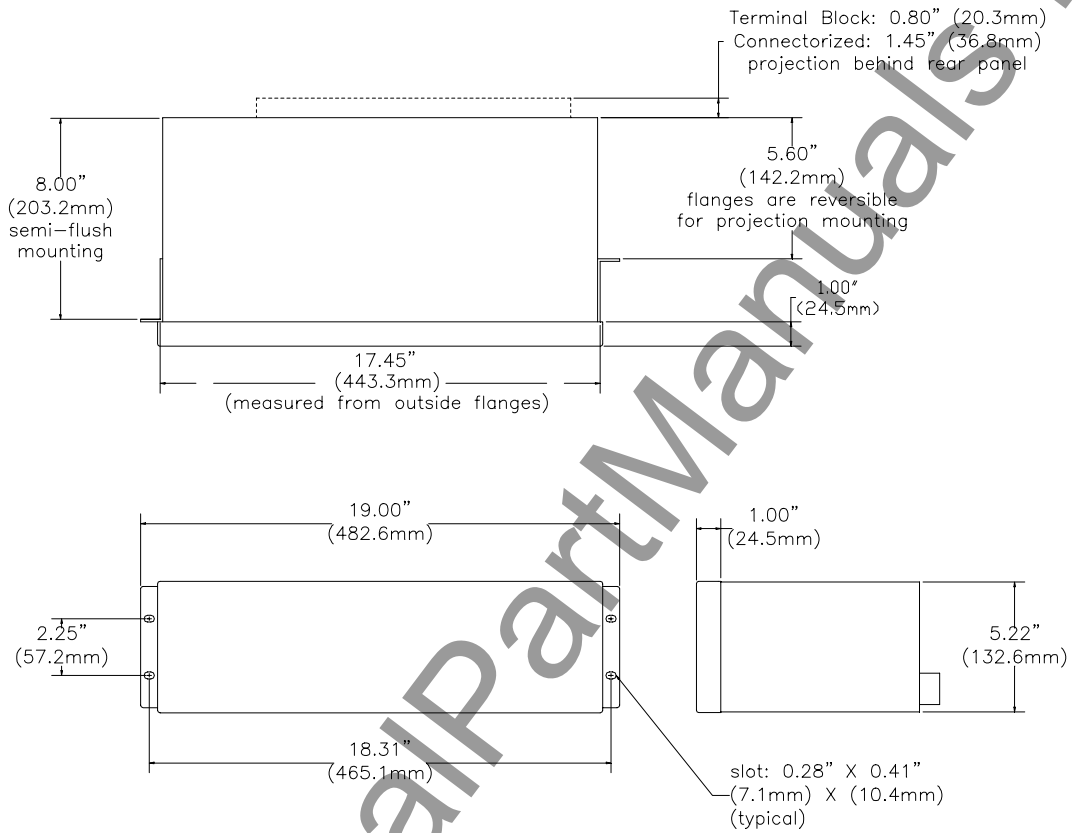
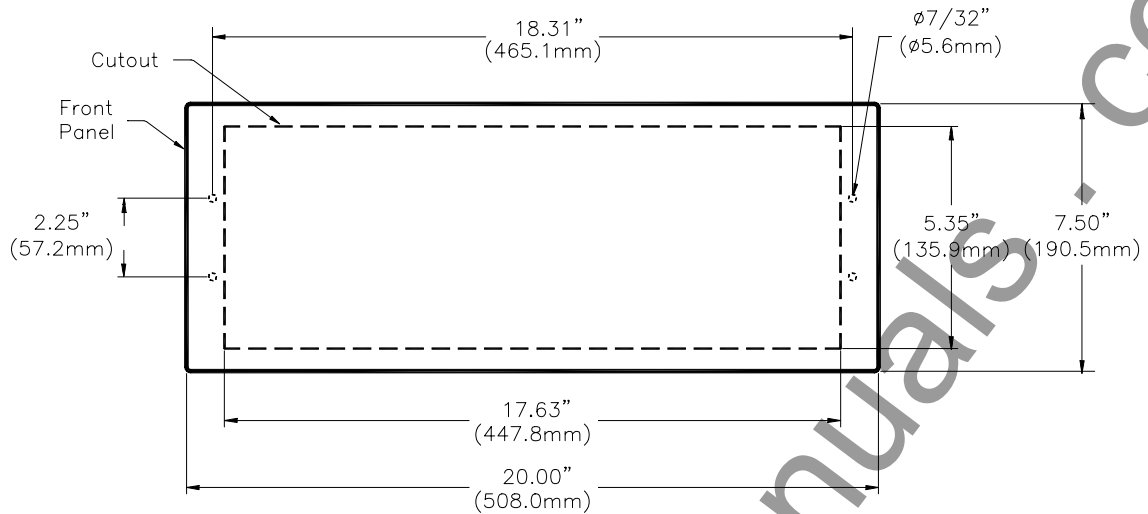

Figure 13: SEL-351S Relay Dimensions and Drill Plan for Rack Mount Models



NOTE:

1. ALL TOLERANCES ARE ± 0.020 " (0.51mm)
2. DRAWING NOT TO SCALE

Dwg: 351S_panelmount
09-09-99

Figure 14: SEL-351S Relay Panel Cut-Out and Drill Plan for Panel Mount Models (horizontal mounting shown; dimensions also apply to vertical mounting)

The 7/32" (5.6 mm) drill holes shown in Figure 14 are to accommodate the four integral #10-32 studs that project out the back of the front panel of the panel-mount relays. These studs are used to fasten the panel-mount relays to the greater panel surface, which has been drilled and cut according to Figure 14 specifications. The panel-mount relays slide in from the front and are fastened (via the integral studs) on the back.

The relay chassis dimensions given in Figure 13 for the rack-mount relays also apply to the panel-mount relays (the rack- and panel-mount relays differ only on the front – the relay chassis is the same). The applicable dimensions are:

Relay chassis depth:	8.00" (203.2 mm)
Extra projection depth:	0.80" (20.3 mm)
Relay chassis width:	17.45" (443.3 mm)
Relay chassis height:	3.47" (88.1 mm)

The front of the panel-mount relays projects out 1.00" (24.5 mm), like the rack-mount relays. But, as shown in Figure 14, the front-panel coverage of the panel-mount relays is intentionally greater to hide any panel cuts.

GUIDEFORM SPECIFICATION

The microprocessor-based relay shall provide a combination of functions including protection, monitoring, control, fault locating, and automation. Relay self-checking functions shall be included. Specific operational and functional requirements are as follows.

Phase Fault Overcurrent Protection: The relay shall incorporate phase and negative-sequence overcurrent elements for detection of phase faults. For added security, the relay shall provide directional elements, load encroachment logic, and torque control capability (internal and external).

Ground Fault Overcurrent Protection: The relay shall incorporate residual ground and neutral ground overcurrent elements for detection of ground faults. For added security, the relay shall provide directional elements and torque control capability (internal and external).

Phase Under- and Overvoltage Elements: The relay shall incorporate undervoltage and overvoltage elements for creating protection and control schemes, including but not limited to: Voltage checks (e.g., hot bus/dead line) for reclosing; Blown transformer high-side fuse detection logic; Control schemes for capacitor banks.

Sequence Voltage Elements: The relay shall incorporate positive, negative, and zero-sequence voltage elements that can be logically configured for either under- or overvoltage applications.

Under- and Overfrequency Protection: The relay shall incorporate six levels of under-/overfrequency elements for detection of power system frequency disturbances. Each setting level shall use an independently set timer for application in load shedding or generator tripping schemes.

Auto-Reclosing Control: The relay shall incorporate a four-shot recloser. It shall include four independently set open time intervals, an independently set reset time from reclose cycle, and independently set reset time from lockout.

Synchronism Check: The relay shall include two synchronism check elements with separate maximum angle settings (e.g., one for auto-reclosing and one for manual closing). The synchronism check function shall compensate for breaker close time and constant phase angle differences between the two voltage sources used for synchronism check (phase angle differences settable in 30° increments).

Coordination with Downstream Reclosers: The relay shall include sequence coordination logic to avoid tripping for faults beyond a line recloser.

Operator Controls: The relay shall include ten operator controls on the relay front panel, whose functions shall also be accessible in the relay control logic. The operator control panel shall include pushbuttons and LEDs with the following markings: Ground Enabled, Reclose Enabled, Remote Enabled, Alternate Settings, Lock, Hot Line Tag, Aux 1, Aux 2, Close/Breaker Closed, and Trip/Breaker Open.

Event Reporting and Sequential Events Recorder: The relay shall be capable of automatically recording disturbance events. The length of event reports shall be either 15 or 30 cycles. The information stored in each event report shall include current, voltage, frequency, and relay element status. Events shall be stored in nonvolatile memory. The relay shall also include a Sequential Events Recorder (SER) that stores the latest 512 entries. Events that trigger an SER entry shall include: input/output change of state, relay element pickup/dropout, and recloser state changes.

Status and Trip Target LEDs: The relay shall include 16 status and trip target LEDs. Twelve (12) of these LEDs are programmable. These programmable LEDs can be set either as a status LED (follow state of user-specified elements or indicators—e.g., dead line indication) or a trip target LED (latch in on trip for user-specified condition—e.g., undervoltage trip).

Overload and Unbalance Alarms: The relay shall include user-settable demand current thresholds for phase, negative-sequence, neutral, and residual demand measurements. Thermal and rolling demand measuring techniques shall be included.

Circuit Breaker Monitor: The relay shall include a breaker wear monitor function. A user-programmable breaker monitor curve shall be provided, so that the user can define the breaker wear curve and settings (kA interrupted vs. number of operations) as per the breaker manufacturer's recommendations.

Substation Battery Monitor: The relay shall measure and report the substation battery voltage presented to the relay power supply terminals. Two user-selectable threshold parameters shall be provided for alarm and control purposes.

Fault Locator: The relay shall include a fault locating algorithm to provide an accurate estimate of fault location without communications channels, special instrument transformers, or pre-fault information.

Automation: The relay shall include features for automating local and remote control functions. Sixteen local control elements (separate from the ten front-panel operator controls) shall be included to enable/disable reclosing, trip/close the breaker, etc. Sixteen remote control logic points shall be included for SCADA-type control operations via the serial port. Sixteen latching logic points shall be included so as to replace traditional latching relays for functions such as "hot line tagging". Sixteen display messages shall be provided in conjunction with a local display panel included in the relay. The relay shall have the capability to display custom messages.

Relay Logic: The relay shall include programmable logic functions for a wide range of user-configurable protection, monitoring, and control schemes.

Communications: The relay shall include three independent EIA-232 serial ports and one EIA-485 serial port for external communications.

IRIG-B: The relay shall include an interface port for a demodulated IRIG-B time synchronization input signal.

GENERAL SPECIFICATIONS

Important: Do not use the following specification information to order an SEL-351S Relay.
Refer to the actual ordering information sheets.

AC Voltage Inputs 300 V_{L-N} continuous (connect any voltage up to 300 Vac). 600 Vac for 10 seconds. Burden: 0.03 VA @ 67 V; 0.06 VA @ 120 V; 0.8 VA @ 300 V.

AC Current Inputs 5 A nominal: 15 A continuous, 500 A for 1 second, linear to 100 A symmetrical. 1250 A for 1 cycle.
Burden: 0.27 VA @ 5 A, 2.51 VA @ 15 A.

1 A nominal: 3 A continuous, 100 A for 1 second, linear to 20 A symmetrical.
250 A for 1 cycle.
Burden: 0.13 VA @ 1 A, 1.31 VA @ 3 A.

Sensitive Earth Fault:

0.05 A nominal channel IN current input: 1.5 A continuous, 20 A for 1 second, linear to 1.5 A symmetrical.
100 A for 1 cycle.
Burden: 0.0004 VA @ 0.05 A, 0.36 VA @ 1.5 A.

Frequency and Rotation 60/50 Hz system frequency and ABC/ACB phase rotation are user-settable.
Frequency tracking range: 40.1 - 65 Hz (V_A required for frequency tracking).

Output Contacts

Standard:

Per IEC 255-0-20 : 1974, using the simplified method of assessment

6 A continuous carry

30 A make per IEEE C37.90 : 1989

100 A for one second

270 Vac/360 Vdc MOV for differential surge protection.

Pickup/dropout time: < 5 ms

Breaking Capacity (L/R = 40 ms):

48 V	0.5 A	10,000 operations
125 V	0.3 A	10,000 operations
250 V	0.2 A	10,000 operations

Cyclic Capacity (L/R = 40 ms):

48 V	0.5 A	2.5 cycles per second
125 V	0.3 A	2.5 cycles per second
250 V	0.2 A	2.5 cycles per second

**Output
Contacts**

High-current interruption option for extra I/O board:

6 A continuous carry
30 A make per IEEE C37.90 : 1989
330 Vdc MOV for differential surge protection
Pickup time: < 5 ms
Dropout time: < 8 ms (typical)
Breaking Capacity: 10 A 10,000 operations
48 and 125 V (L/R = 40 ms)
250 V (L/R = 20 ms)
Cyclic Capacity: 10 A 4 cycles in 1 second, followed
by 2 minutes idle for thermal dissipation
48 and 125 V (L/R = 40 ms)
250 V (L/R = 20 ms)

Note: Do not use high-current interrupting output contacts to switch ac control signals. These outputs are polarity-dependent.

**Optoisolated
Input Ratings**

250 Vdc: on for 200 - 300 Vdc; off below 150 Vdc
125 Vdc: on for 105 - 150 Vdc; off below 75 Vdc
110 Vdc: on for 88 - 132 Vdc; off below 66 Vdc
48 Vdc: on for 38.4 - 60 Vdc; off below 28.8 Vdc
24 Vdc: on for 15 - 30 Vdc

With nominal control voltage applied, each optoisolated input draws approximately 4 mA of current.

**Time-Code
Input**

Relay accepts demodulated IRIG-B time-code input at Port 2. Relay time is synchronized to within ± 5 ms of time-source input.

**Serial
Communications**

Two rear-panel and one front-panel EIA-232 serial communications ports. One rear-panel EIA-485 serial port with 2100 Vdc of isolation.

Per Port Baud Rate Selections: 300, 1200, 2400, 4800, 9600, 19200, 38400

Power Supply

125/250 V supply 85 - 350 Vdc or 85 - 264 Vac; <15 W
24/48 V supply: 20 - 60 Vdc; <15 W

Dimensions

See Figure 13 and Figure 14.

Weight

16 lbs (7.24 kg) — 3U rack unit height relay

**Routine
Dielectric Test**

Current inputs: 2500 Vac for 10 seconds.
Power supply, optoisolated inputs, and output contacts: 3000 Vdc for 10 seconds.

The following *IEC 255-5 Dielectric Tests : 1977* are performed on all units with the CE mark:

2500 Vac for 10 seconds on analog inputs.
3100 Vdc for 10 seconds on power supply, optoisolated inputs, and output contacts.

**Operating
Temp.**

-40° to 185°F (-40° to +85°C) (type test).
(LCD contrast impaired for temperatures below -20°C.)

IEC 68-2-1: 1990 Basic environmental testing procedures, Part 2: Tests - Test Ad: Cold (type test).

IEC 68-2-2: 1974 Basic environmental testing procedures, Part 2: Tests - Test Bd: Dry Heat (type test).

Environment

IEC 68-2-30: 1980 Basic environmental testing procedures, Part 2: Tests, Test Db and guidance: Damp heat, cyclic (12 + 12-hour cycle), (six-day type test).

RFI and Interference Tests

IEEE C37.90.1 - 1989 IEEE SWC Tests for Protective Relays and Relay Systems (3 kV oscillatory, 5 kV fast transient) (type test).

IEEE C37.90.2 IEEE Trial-Use Standard, Withstand Capability of Relay Systems to Radiated Electromagnetic Interference from Transceivers, 10 V/m (type test).

Exceptions:

5.5.2(2) Performed with 200 frequency steps per octave.

5.5.3 Digital Equipment Modulation Test not performed.

5.5.4 Test signal turned off between frequency steps to simulate keying.

IEC 801-4: 1988 Electromagnetic compatibility for industrial-process measurement and control equipment, Part 4: Electrical fast transient/burst requirements, Severity Level 4 (4 kV on power supply, 2 kV on inputs and outputs) (type test).

IEC 255-22-1: 1988 Electrical disturbance tests for measuring relays and protection equipment, Part 1: 1 MHz burst disturbance tests. Severity Level 3 (2.5 kV common mode, 1.0 kV differential) (type test).

IEC 255-22-3: 1989 Electrical relays, Section 3: Radiated electromagnetic field disturbance tests, Severity Level 3 (10 V/m) (type test).

IEC 255-22-4: 1992 Electrical disturbance tests for measuring relays and protection equipment, Section 4 - Fast transient disturbance test (type test).

Impulse Tests

IEC 255-5: 1977 Electrical relays, Part 5: Insulation tests for electrical relays, Section 6: Dielectric Tests, Series C (2500 Vac on analog inputs; 3000 Vdc on power supply, contact inputs, and contact outputs). Section 8: Impulse Voltage Tests, 0.5 Joule 5 kV (type test).

Vibration and Shock Test

IEC 255-21-1: 1988 Electrical relays, Part 21: Vibration, shock, bump, and seismic tests on measuring relays and protection equipment, Section One - Vibration tests (sinusoidal), Class 1 (type test).

IEC 255-21-2: 1988 Electrical relays, Part 21: Vibration, shock, bump, and seismic tests on measuring relays and protection equipment, Section Two - Shock and bump tests, Class 1 (type test).

IEC 255-21-3: 1993 Electrical relays, Part 21: Vibration, shock, bump, and seismic tests on measuring relays and protection equipment, Section Three - Seismic tests, Class 2 (type test).

ESD Test *IEC 255-22-2: 1996 Electrical disturbance tests for measuring relays and protective equipment, Section 2: Electrostatic discharge tests, Severity Level 4 (8 kV contact discharge all points except serial ports, 15 kV air discharge to all other points) (type test).*

Processing Specifications

AC Voltage and Current Inputs 16 samples per power system cycle, 3 dB low-pass filter cut-off frequency of 560 Hz.

Digital Filtering One cycle cosine after low-pass analog filtering.
Net filtering (analog plus digital) rejects dc and all harmonics greater than the fundamental.

Protection and Control Processing Four times per power system cycle.

Relay Element Pickup Ranges and Accuracies

Instantaneous/Definite-Time Overcurrent Elements

Pickup Range:	0.25 - 100.00 A, 0.01 A steps (5 A nominal) 1.00 - 170.00 A, 0.01 A steps (5 A nominal – for phase-to-phase elements) 0.05 - 20.00 A, 0.01 A steps (1 A nominal) 0.20 - 34.00 A, 0.01 A steps (1 A nominal – for phase-to-phase elements) 0.005 - 1.500 A, 0.001 A steps (0.05 A nominal channel IN current input)
Steady-State Pickup Accuracy:	±0.05 A and ±3% of setting (5 A nominal) ±0.01 A and ±3% of setting (1 A nominal) ±1 mA and ±5% of setting (0.05 A nominal channel IN current input)
Transient Overreach:	±5% of pickup
Time Delay:	0.00 - 16,000.00 cycles, 0.25-cycle steps
Timer Accuracy:	±0.25 cycle and ±0.1% of setting

Time-Overcurrent Elements

Pickup Range:	0.50 - 16.00 A, 0.01 A steps (5 A nominal) 0.10 - 3.20 A, 0.01 A steps (1 A nominal) 0.005 - 0.160 A, 0.001 A steps (0.05 A nominal channel IN current input)
Steady-State Pickup Accuracy:	± 0.05 A and $\pm 3\%$ of setting (5 A nominal) ± 0.01 A and $\pm 3\%$ of setting (1 A nominal) ± 1 mA and $\pm 5\%$ of setting (0.05 A nominal channel IN current input)
Time Dial Range:	0.50- 15.00, 0.01 steps (US) 0.05 - 1.00, 0.01 steps (IEC)
Curve Timing Accuracy:	± 1.50 cycles and $\pm 4\%$ of curve time for current between 2 and 30 multiples of pickup

Under- and Overvoltage Elements

Pickup Ranges:	0.00 - 300.00 V, 0.01 V steps (various elements) 0.00 - 520.00 V, 0.01 V steps (phase-to-phase elements)
Steady-State Pickup Accuracy:	± 2 V and $\pm 5\%$ of setting
Transient Overreach:	$\pm 5\%$ of pickup

Synchronism-Check Elements

Slip Frequency Pickup Range:	0.005 - 0.500 Hz, 0.001 Hz steps
Slip Frequency Pickup Accuracy:	± 0.003 Hz
Phase Angle Range:	0 - 80°, 1° steps
Phase Angle Accuracy:	$\pm 2^\circ$

Under- and Overfrequency Elements

Pickup Range:	40.10 - 65.00 Hz, 0.01 Hz steps
Steady-State <i>plus</i> Transient Overshoot:	± 0.01 Hz
Time Delay:	2.00 - 16,000.00 cycles, 0.25-cycle steps
Timer Accuracy:	± 0.25 cycle and $\pm 0.1\%$ of setting

Timers

Pickup Ranges:	0.00 - 999,999.00 cycles, 0.25-cycle steps (reclosing relay and some programmable timers)
	0.00 - 16,000.00 cycles, 0.25-cycle steps (some programmable and other various timers)
Pickup and dropout accuracy for all timers:	± 0.25 cycle and $\pm 0.1\%$ of setting

Substation Battery Voltage Monitor

Pickup Range:	20 - 300 Vdc, 1 Vdc steps
Pickup Accuracy:	$\pm 2\%$ of setting

Metering Accuracy

Accuracies are specified at 20°C and at nominal system frequency unless noted otherwise.

Voltages $V_A, V_B, V_C, V_S, 3V_0, V_1, V_2$	$\pm 0.2\%$ (67.0 - 300 V; wye-connected)
Currents I_A, I_B, I_C	± 1 mA and $\pm 0.1\%$ (0.5 - 10 A) (5 A nominal)
	± 0.2 mA and $\pm 0.1\%$ (0.1 - 2 A) (1 A nominal)
	Temperature coefficient: $[(0.0002\%)/(\text{°C})^2] * (\text{°C} - 20\text{°C})^2$ (see following example)
Currents $I_N, I_1, 3I_0, 3I_2$	± 0.05 A and $\pm 3\%$ (0.5 - 100 A) (5 A nominal)
	± 0.01 A and $\pm 3\%$ (0.1 - 20 A) (1 A nominal)
	± 1 mA and $\pm 5\%$ (0.01 - 1.5 A) (0.05 A nominal channel IN current input)
Phase Angle Accuracy	$\pm 0.5^\circ$

MW / MVAR
(A, B, C, and 3-phase; 5 A nominal;
wye-connected voltages)

Accuracy (MW / MVAR)	at load angle
for 0.5 A ≤ phase current < 1.0 A s:	
0.70% / -	0° or 180° (unity power factor)
0.75% / 6.50%	±8° or ±172°
1.00% / 2.00%	±30° or ±150°
1.50% / 1.50%	±45° or ±135°
2.00% / 1.00%	±60° or ±120°
6.50% / 0.75%	±82° or ±98°
- / 0.70%	±90° (power factor = 0)

for phase current ≥ 1.0 A s:

0.35% / -	0° or 180° (unity power factor)
0.40% / 6.00%	±8 or ±172°
0.75% / 1.50%	±30° or 150°
1.00% / 1.00%	±45° or ±135°
1.50% / 0.75%	±60° or ±120°
6.00% / 0.40%	82° or ±98°
- / 0.35%	±90° (power factor = 0)

Metering accuracy calculation example for currents I_A, I_B, and I_C due to preceding stated temperature coefficient:

For temperature of 40°C, the additional error for currents I_A, I_B, and I_C is:

$$[(0.0002\%)/(\text{°C})^2] \cdot (40\text{°C} - 20\text{°C})^2 = 0.08\%$$

Power Element Accuracy

Pickup: ±0.005 A • (voltage secondary) and ±5% of setting at unity power factor { 1 A nom }
±0.025 A • (voltage secondary) and ±5% of setting at unity power factor { 5 A nom }

FACTORY ASSISTANCE

The employee-owners of Schweitzer Engineering Laboratories, Inc. are dedicated to making electric power safer, more reliable, and more economical.

We appreciate your interest in SEL products, and we are committed to making sure you are satisfied. If you have any questions, please contact us at:

Schweitzer Engineering Laboratories, Inc.
2350 NE Hopkins Court
Pullman, WA USA 99163-5603
Tel: (509) 332-1890
Fax: (509) 332-7990

We guarantee prompt, courteous, and professional service.

We appreciate receiving any comments and suggestions about new products or product improvements that would help us make your job easier.

All brand or product names appearing in this document are the trademark or registered trademark of their respective holders.

Schweitzer Engineering Laboratories, Inc., SELOGIC, Connectorized, and **SEL** are registered trademarks of Schweitzer Engineering Laboratories, Inc.

This product is covered by U.S. Patent Nos: 5,041,737; 5,208,545; 5,317,472; 5,349,490; 5,365,396; 5,479,315; 5,515,227; 5,602,707; 5,652,688; 5,694,281; 5,793,750; 5,790,418; 5,883,578; Foreign Patents issued and other U.S. and Foreign Patents Pending.

Copyright © SEL 1999 (All rights reserved) Printed in USA.

SEL-351S Protection and Breaker Control Relay Data Sheet

991008



Schweitzer Engineering Laboratories

2350 NE Hopkins Court • Pullman, WA 99163-5603 USA

Phone: (509) 332-1890 • Fax: (509) 332-7990

Internet: www.selinc.com • E-mail: info@selinc.com