

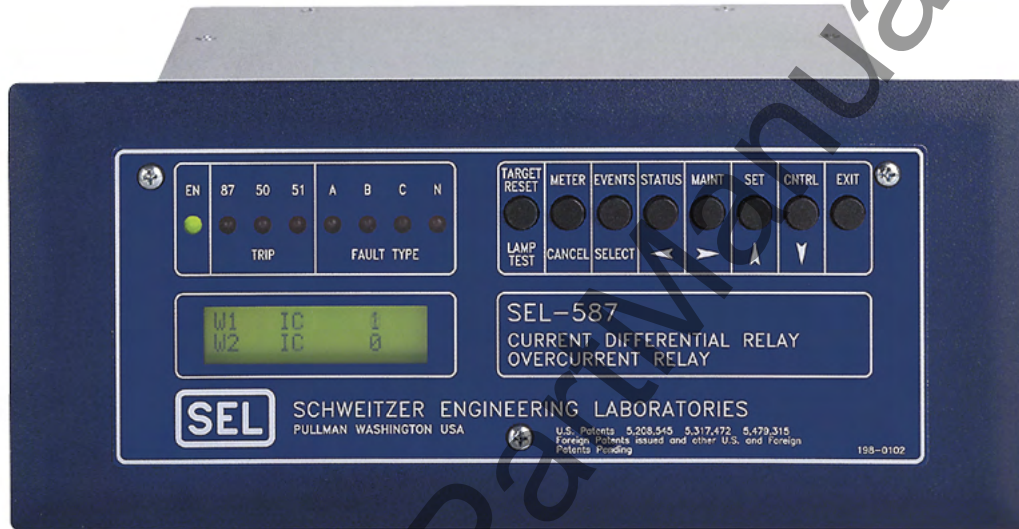

SEL-587 Current Differential Relay

Economical Differential Protection for Power Apparatus



Major Features and Benefits

The SEL-587 Current Differential Relay combines overcurrent and differential elements in an easy-to-apply power apparatus differential protection package. Relay security is achieved by an optimized set of user-selectable restraining and blocking elements. Dual-slope percentage, harmonic *restraint* and *blocking*, plus dc blocking are included. Zero-sequence currents are filtered out from the differential element for any combination of power and transformer CT connections. SELOGIC[®] control equations provide application flexibility when conditions warrant.

- **Protection.** Protect two-terminal transformers, generators, reactors, and other power apparatus using a combination of differential, instantaneous, definite-, and inverse-time overcurrent elements. Differential scheme security is achieved by the following:
 - Dual-slope percentage restraint
 - Second- and fourth-harmonic blocking or restraint plus dc blocking for magnetizing inrush
 - Fifth-harmonic blocking for transformer overexcitation
 - CT and transformer connection compensation
- **Monitoring.** Metering quantities are available for phase, ground, negative-sequence, differential, and harmonic currents. Post-fault analysis is simplified by information recorded in event reports having 15-cycle duration times. As many as 10 event reports are stored in nonvolatile memory. Self-test and alarm functions are standard.
- **Relay and Logic Settings Software.** ACSELERATOR[®] QuickSet[™] SEL-5030 Software reduces engineering costs for relay settings and logic programming. The built-in Human Machine Interface (HMI) provides phasor diagrams that help support commissioning and troubleshooting.

Functional Overview

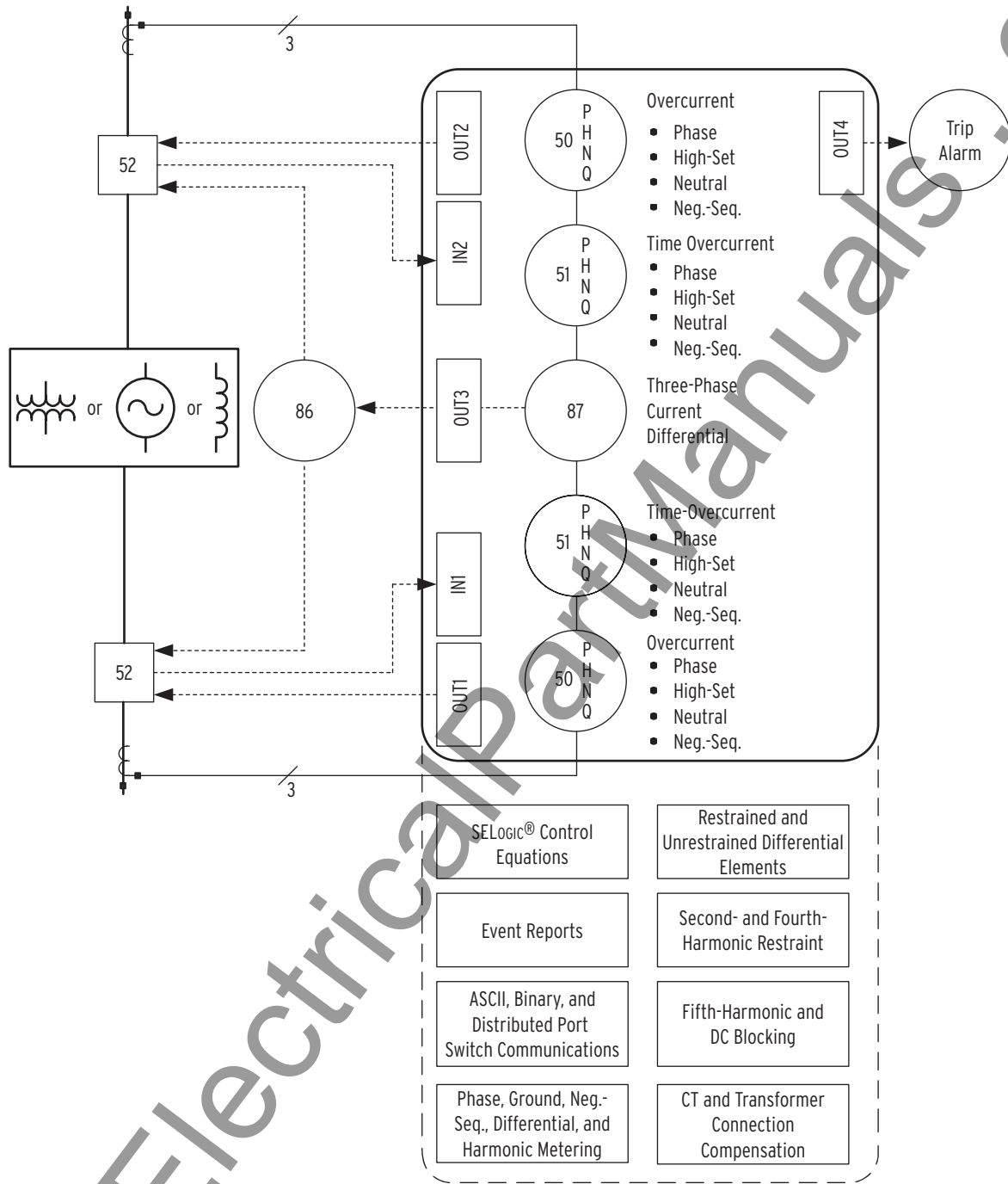

Figure 1 Functional Diagram

Model Variations

SEL-587-0 Relay

The SEL-587-0 has provided sophisticated and reliable service for many years. However, we recommend using the SEL-587-1 Relay for new designs because of the additional features it provides.

SEL-587-1 Relay

Differences between the SEL-587-0 and the SEL-587-1 are explained below.

- The SEL-587-0 trip logic can be set in one of two configurations, while the SEL-587-1 can be set in one of three configurations. The trip logic of each relay can be set to always latch the trip or to latch the trip if the current is above a certain threshold. The SEL-587-1 adds the ability to block trip latching.
- Each relay provides the ability to protect transformers with a variety of transformer and CT connections. Phase-angle shifts are compensated for and zero-sequence current is removed in most cases. The SEL-587-1 adds the ability to remove zero-sequence current in transformers with grounding banks within the differential zone or zigzag transformer applications.

- In addition to the harmonic blocking capabilities of the SEL-587-0, the SEL-587-1 provides second- and fourth-harmonic restraint and dc blocking capabilities.

Two Rear-Panel Options

Conventional Terminal Blocks

This model includes hardware that supports six current inputs, two optoisolated inputs, four programmable output contacts, one alarm contact, one EIA-232 port, and IRIG-B time code. It uses terminal blocks that support #6 ring terminals. This robust package meets or exceeds numerous industry standard type tests.

Features of the conventional terminal block option are the following:

- Output contacts **OUT1–OUT4** and **ALARM** are not polarity-dependent.
- Optoisolator inputs **IN1** and **IN2** are not polarity-dependent.
- All screws are size #6-32.
- This relay is available in a 3.5" (2U) rack-mount package or a 4.9" panel-mount package.

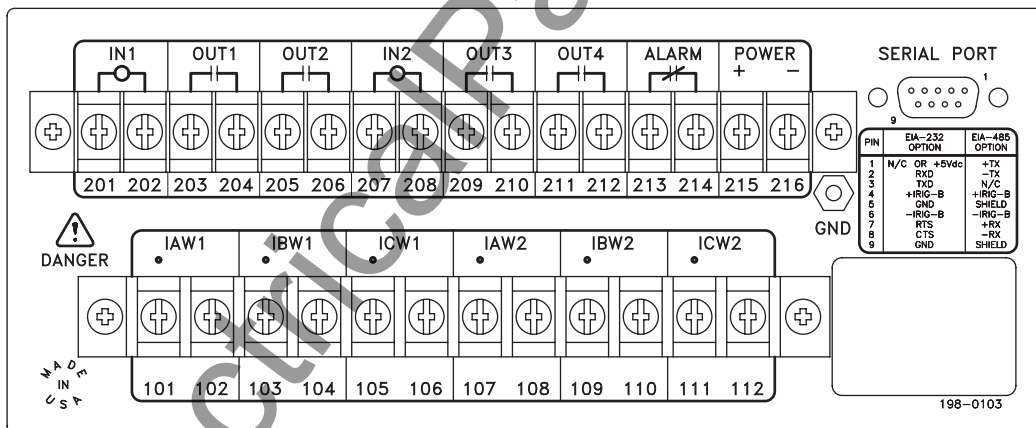

13043a

Figure 2 Relay Rear Panel (Conventional Terminal Blocks Option)

Plug-In Connectors (Connectorized®)

This model includes hardware that supports all of the features of the conventional terminal block model. It differs in its use of plug-in connectors instead of terminal blocks. In addition, it provides:

- High-current interrupting output contacts.
- Quick connect/release hardware for rear-panel terminals.
- Level-sensitive optoisolated inputs.

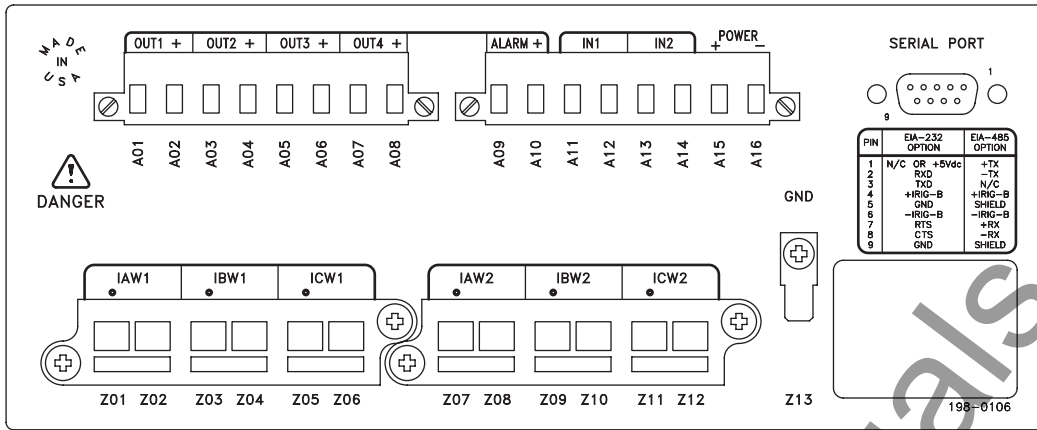

i3047a

Figure 3 Relay Rear Panel (Plug-In Connectors Option)

This robust package meets or exceeds numerous industry standard type tests. It is available in a 3.5" (2U) rack-mount package or a 4.9" panel-mount package.

IMPORTANT: Improvements in Connectorized SEL-587 relays (Plug-In Connectors) result in part number changes.

The current transformer shorting connectors for current channel inputs IAW1, IBW1, ICW1, and IAW2, IBW2, and ICW2 have been made more robust. Thus, new Connectorized SEL-587 relays with this improved connector have a new part number (partial part number shown below):

Old	New
0587xJ	0587xW

The respective wiring harness part numbers for these old and new Connectorized SEL-587 relays are (partial part numbers shown):

Old	New
WA0587xJ	WA0587xW

The other connectors on the SEL-587 rear panel (power input, output contacts, etc.) are the same for the old or new models. Only the current transformer shorting connectors have changed.

Figure 3 shows the rear panel for new model 0587xW. Because all terminal labeling/numbering remains the same between the new and old relays, these figures can also be used as a reference for old model 0587xJ. Only the connectors and part numbers have changed.

Connector terminals A01–A16 and ALARM are polarity-dependent.

Current input connector (terminals Z01–Z12):

- ▶ Contains current transformer shorting mechanisms
- ▶ Accepts wire size AWG 16 to 10 (special tool required to attach wire to connector)
- ▶ Can be ordered prewired

Ground connection (terminal Z13): tab size 0.250" x 0.032", screw size #6-32.

Relay Elements

Table 1 Relay Elements

Restrained and Unrestrained Differential Element Settings	Setting	Setting Range
Operating-Current Pickup	O87P	(0.1–1.0), TAP
Restraint Slope 1 Percentage	SLP1	5–100%
Restraint Slope 2 Percentage	SLP2	OFF, 50–200%
Restraint-Current Slope 1 Limit	IRS1	(1–16), TAP
Instantaneous-Unrestrained-Current Pickup	U87P	(1–16), TAP
Second-Harmonic Blocking Percentage	PCT2	OFF, 5–100%
Fourth-Harmonic Blocking Percentage	PCT4	OFF, 5–100%
Fifth-Harmonic Blocking Percentage	PCT5	OFF, 5–100%

The relay automatically calculates TAP values from transformer ratings, CT ratios, and connections.

Table 2 Overcurrent Elements

Eight Overcurrent Elements for Winding 1	Instantaneous	Definite Time	Inverse Time
Phase	50P1H	50P1	51P1
Negative Sequence		50Q1	51Q1
Residual	50N1H	50N1	51N1
Eight Overcurrent Elements for Winding 2	Instantaneous	Definite Time	Inverse Time
Phase	50P2H	50P2	51P2
Negative Sequence		50Q2	51Q2
Residual	50N2H	50N2	51N2
Setting Ranges, 5 A Model, (A secondary)	OFF, (0.5–80)	OFF, (0.5–80)	OFF, (0.5–16)
Setting Ranges, 1 A Model, (A secondary)	OFF, (0.1–16) OFF Disables Element	OFF, (0.1–16)	OFF, (0.1–3.2) ANSI and IEC curves

Percentage Differential Element

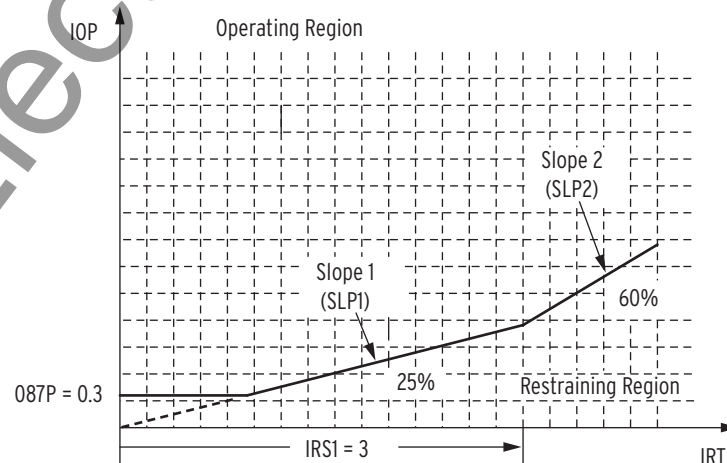
Figure 4 Percentage Differential Element

Operation, Metering, Control, and Reporting

Apply This Relay to Protect

- Any two-winding power transformer
- Three-winding power transformers where the tertiary winding is not connected
- Reactors, generators, large motors, and other two-terminal power apparatus

Smart Relay Settings Simplify Current Connections

- Relay accepts delta- or wye-connected CT secondary circuits
- Enter transformer ratings and connections, CT ratios and connections
- Relay calculates TAP values, corrects CT ratios and transformer ratios
- CT secondary circuits are isolated, allowing them to be connected to other protection

High-Side and Low-Side Overcurrent Elements Provide Additional Protection

- Use high-side overcurrent elements for built-in transformer backup protection
- Negative-sequence overcurrent elements detect ground faults through delta-wye transformer banks
- Use low-side overcurrent elements for backup distribution bus or feeder protection
- Negative-sequence overcurrent elements provide sensitive phase-phase protection independent of load current

Externally Torque-Controlled Overcurrent Elements

- Optionally, select relay control inputs to supervise overcurrent elements
- Select torque-controlled overcurrent elements individually
- Implement a reverse interlocking scheme for fast-bus tripping on radial systems
- Provide external directional supervision

Operator Controls and Serial Communications

- Front-panel pushbuttons and display
- Complete operation from rear-panel EIA-232 serial communications port

- Full access to event history, relay status, and meter information
- Passcode-protected settings and controls

Current Meter Functions

- Provides instantaneous, demand, and peak demand current magnitudes for both windings
- Calculates operate, restraint, second-, and fifth-harmonic current magnitudes
- Records peak demand and peak harmonic current magnitudes

Breaker Monitor and Control

- Saves trip counters and accumulated, interrupt current in nonvolatile memory
- Controls each breaker with separate **OPEN** and **CLOSE** commands

SELOGIC Control Equations

- Assign input functions
- Create application-specific output functions
- Design unique trip and control schemes
- Minimize external timers, auxiliary relays, wiring, and panel space
- Obtain event reporting for all relay elements, inputs, and outputs

Event Reporting

- Relay stores 10 reports in nonvolatile memory
- Reports have 15-cycle duration
- Each event report has two parts:
 - Part 1 shows input currents, overcurrent elements, general differential elements, inputs, and outputs.
 - Part 2 shows operating restraint currents, maximum second- and fifth-harmonic currents, more detailed information of the differential elements, and the remaining elements.

Relay and Logic Setting Software

The ACSELERATOR QuickSet software uses the Microsoft® Windows® operating system to simplify settings and provide analysis support for the SEL-587.

One can, for instance, open an ACSELERATOR QuickSet HMI screen and obtain phasor information similar to that shown in *Figure 5*.

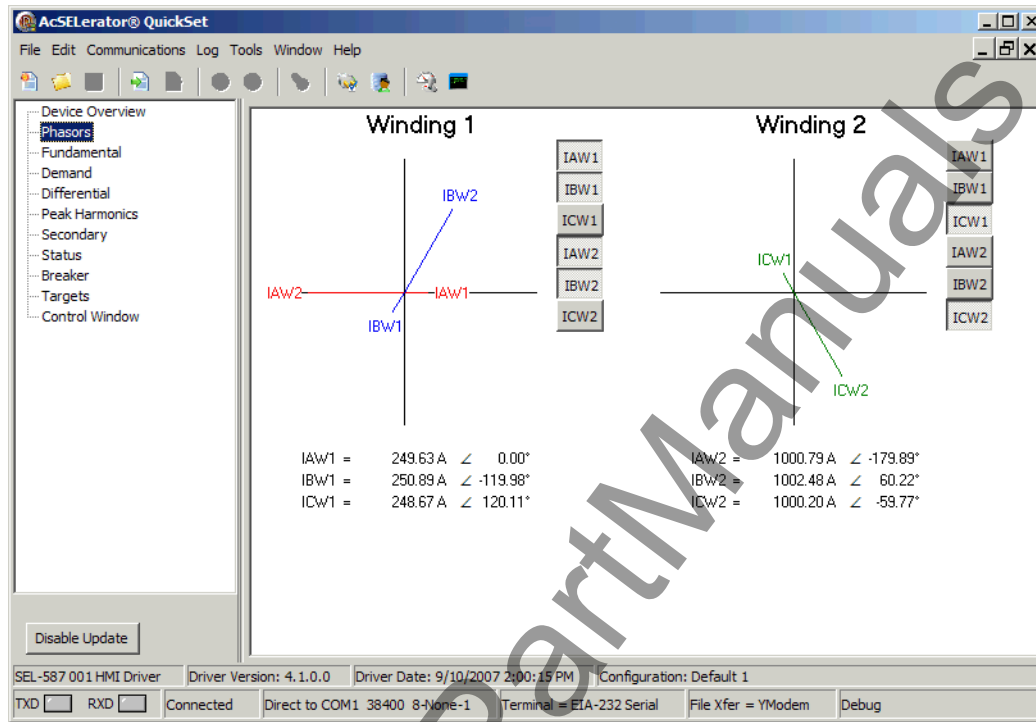

Figure 5 ACSELERATOR QuickSet HMI Screen Showing SEL-587 Phasor Information

Use the ACSELERATOR QuickSet software to create and manage relay settings:

- Develop settings off-line with an intelligent settings editor that only allows valid settings.
- Use on-line help to assist with configuration of proper settings.
- Organize settings with the relay database manager.
- Load and retrieve settings through use of a simple PC communications link.

Use the ACSELERATOR QuickSet software to verify settings and analyze events:

- Analyze power system events with integrated waveform and harmonic analysis tools.

Use the ACSELERATOR QuickSet software to aid with monitoring, commissioning, and testing the SEL-587:

- Use the HMI to monitor current phasor information during testing.
- Use the PC interface to remotely obtain power system data.

Note: To use ACSELERATOR QuickSet software in the SEL-587 Relay, the relay must have firmware version R702 or later.

Guideform Specification

The microprocessor-based relay shall provide a combination of functions including protection, monitoring, control, automation, and relay self-checking. Specific requirements are listed below:

- ▶ **Percentage Differential Protection.** The relay shall incorporate restrained differential protection for two windings with fixed or variable percentage characteristic, using one or two settable slopes with adjustable intersection point and minimum pickup values.
- ▶ **Harmonic Blocking.** The relay shall provide the option of either second- and fifth-harmonic blocking or second- and fourth-harmonic restraint and dc blocking. This feature prevents restrained differential element operation during inrush or overexcitation conditions; independent fifth-harmonic alarm element shall be included to warn user of overexcitation condition.
- ▶ **Unrestrained Differential Protection.** The relay shall include unrestrained differential protection to produce rapid tripping for severe internal faults.
- ▶ **Zero-Sequence Removal.** The relay shall provide zero-sequence removal for all grounded-wye windings, including grounding banks on delta-connected windings.
- ▶ **Tap Quantities.** The relay shall provide automatic calculation of HV and LV tap quantities.
- ▶ **Overcurrent Fault Protection.** The relay shall incorporate two groups of three-phase current inputs for overcurrent protection. Eight overcurrent elements per group shall be included to provide phase, negative-sequence, and residual protection.
- ▶ **Adaptive Phase Overcurrent Elements.** The relay shall incorporate adaptive phase overcurrent elements that perform reliably in the presence of current transformer saturation, dc offset, and off-frequency harmonics.
- ▶ **CT Phase Angle Compensation.** The relay shall incorporate current compensation to accommodate most popular transformer and CT connections such as wye-wye, YDAB, YDAC, etc.
- ▶ **Status and Trip Target LEDs.** The relay shall include eight status and trip target LEDs.
- ▶ **Communication.** The relay shall include one EIA-232 or one EIA-485 serial port to provide flexible communication to external computers and control systems. The relay shall operate at a speed of 300–38400 baud. Three-level password protection shall be included to provide remote security communications. Modbus[®], ASCII, and binary protocols shall be available for communication with SCADA, local HMI, or modems.
- ▶ **Relay Logic.** The relay shall include programmable logic functions for user-configurable protection, monitoring, and control schemes.
- ▶ **Auxiliary Inputs/Outputs.** The relay shall include fully programmable optoisolated inputs and output contacts.
- ▶ **Trip and Close Variables.** The relay shall include three trip variables and two close functions to permit separate control of up to two breakers and a separate lockout device.
- ▶ **Metering.** The relay shall include metering capabilities for real-time current and differential quantities, as well as phase demand and peak demand current values. Second- and fifth-harmonic currents shall also be included.
- ▶ **Event Reporting.** The relay shall be capable of automatically recording disturbance events of 15 cycles with user-defined triggering. Events shall be stored in nonvolatile memory.
- ▶ **Internal Real-Time Clock.** The relay shall include a real-time clock, with battery backup, synchronizable to demodulated IRIG-B input, to provide accurate time stamps for event records.
- ▶ **Low-Level Testing.** The relay shall include a low-level test interface to permit relay testing with low-energy test equipment.

Wiring Diagrams

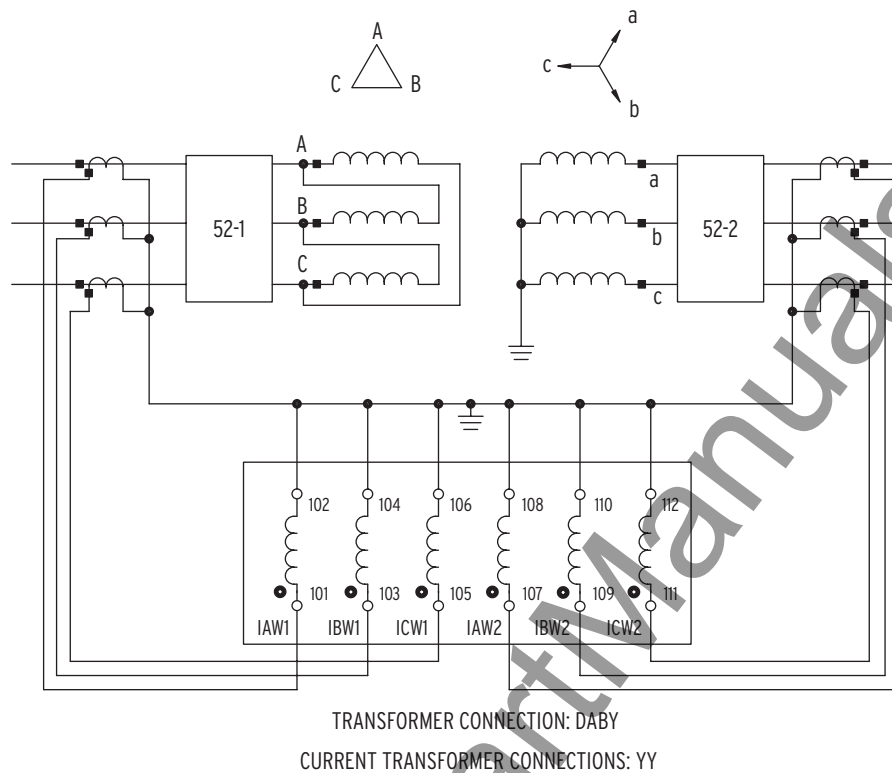

Figure 6 Typical AC Connection Diagram, Three-Winding Autotransformer Application

- Relay automatically compensates for power transformer phase shift and ratio scaling.
- Protects delta-wye, wye-delta, delta-delta, and wye-wye transformers.
- Accepts delta- or wye-connected CTs on either side of the transformer.

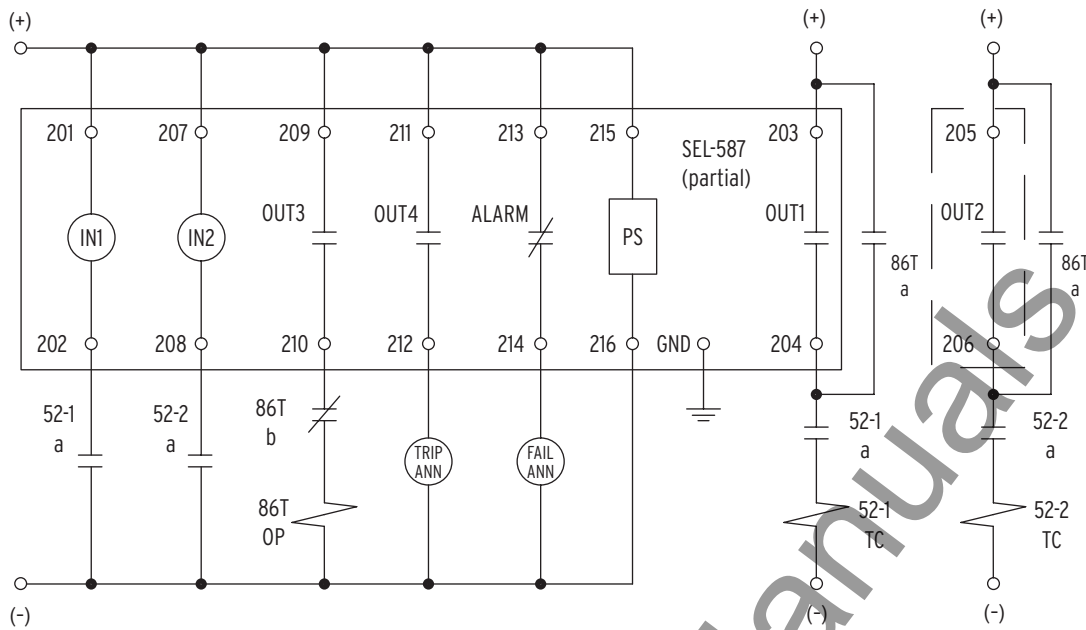
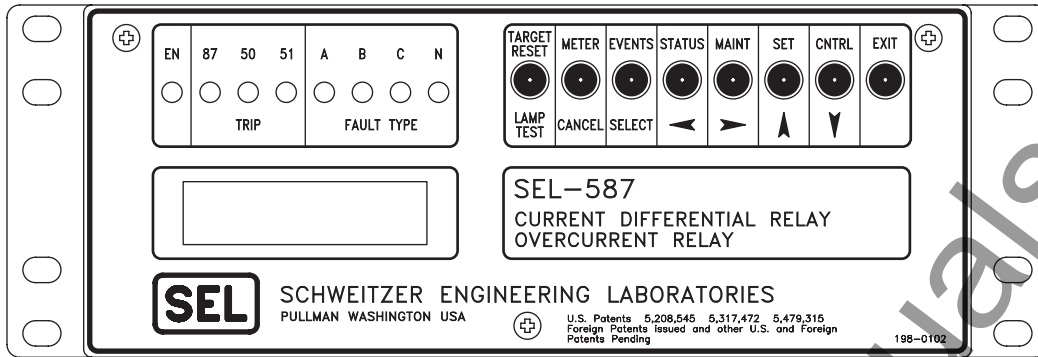

Figure 7 Typical DC Connection Diagram, Three-Winding Transformer Application

- Relay outputs are programmable to support a variety of applications.
- In this example, **OUT1** and **OUT2** provide high-side and low-side overcurrent tripping. **OUT3** operates the transformer lockout auxiliary for differential element operations.

Front- and Rear-Panel Diagrams



Relay Front Panel, Rack-Mount Version (Half Rack Width)

i3044a

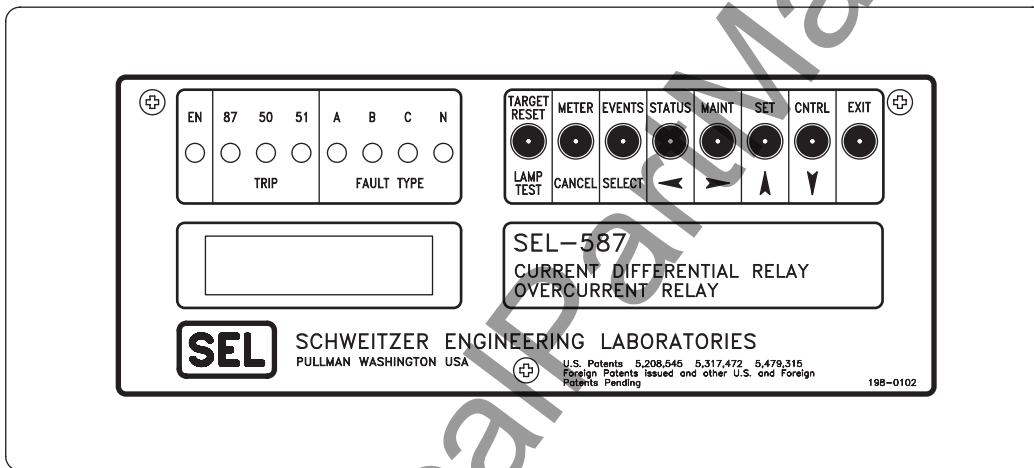

Relay Front Panel, Panel-Mount Version

i3046a

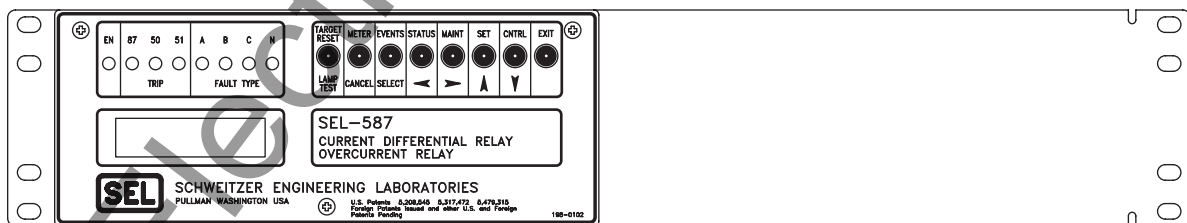

Relay Fitted With Mounting Bracket (SEL P/N 9100) for Mounting in 19-Inch Rack

i3045a

Figure 8 SEL-587 Front Panels

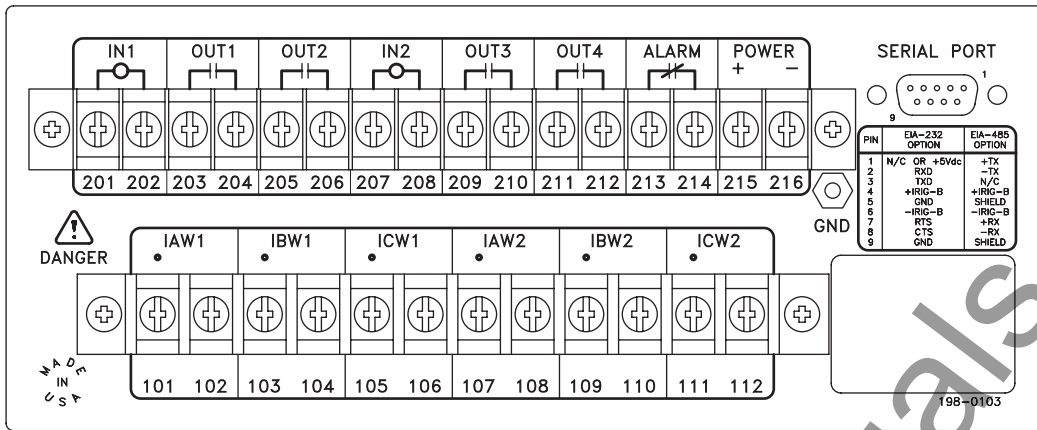

Relay Rear Panel, Conventional Terminal Blocks Version

i3043a

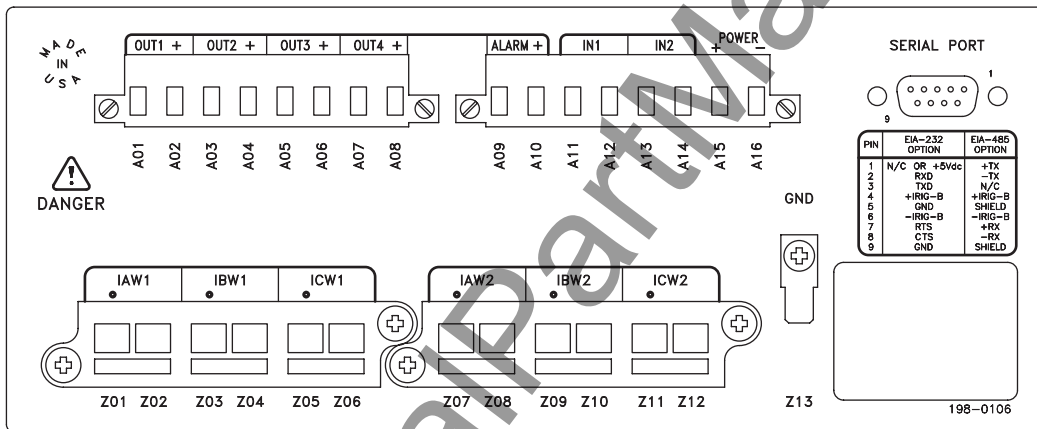

Relay Rear Panel, Plug-In Connectors Version

i3047a

Figure 9 SEL-587 Rear Panel Diagrams

Relay Dimensions

PANEL-MOUNT CHASSIS

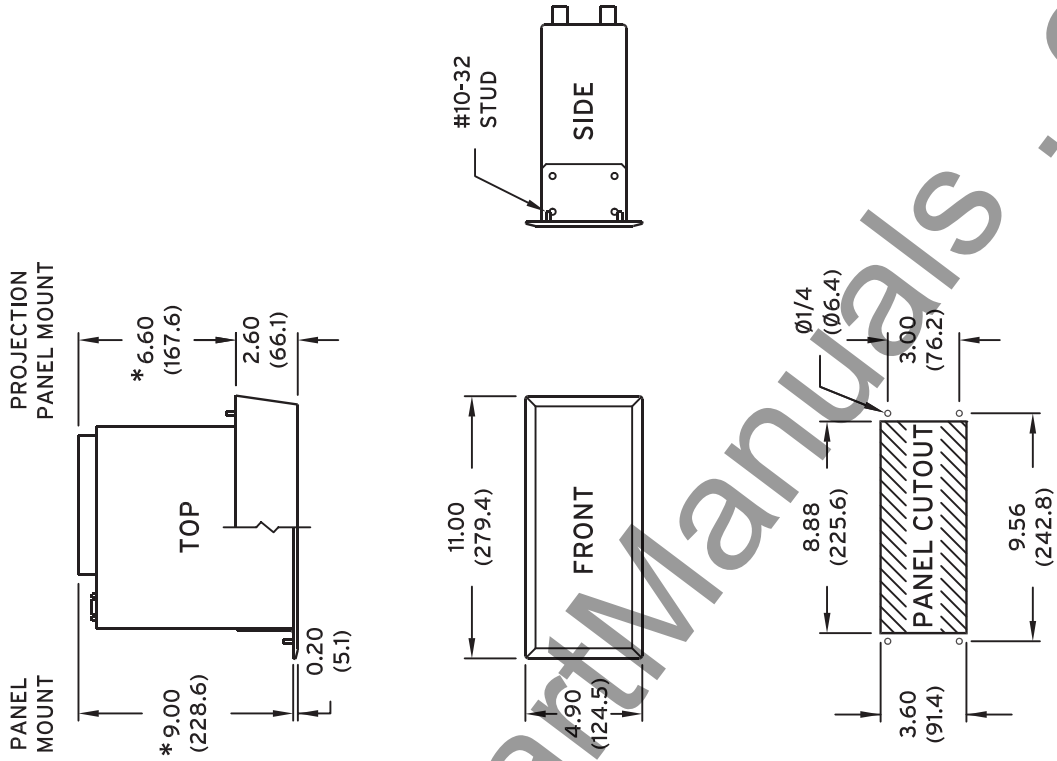

RACK-MOUNT CHASSIS

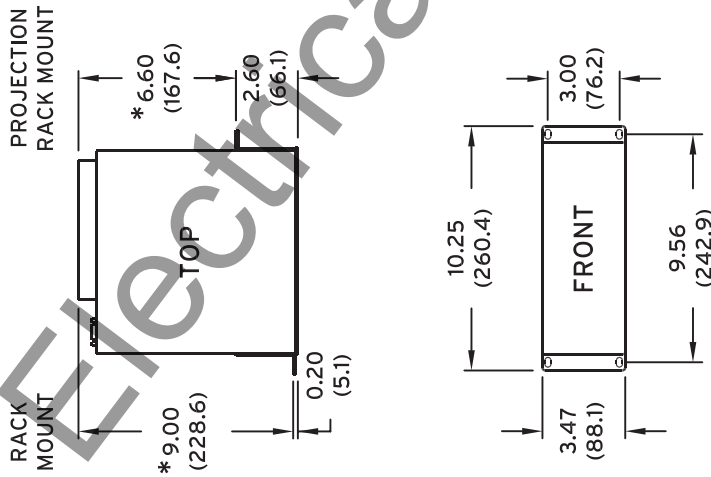

LEGEND
 in (mm)

* ADD 0.80 (20.3) FOR CONNECTORIZED RELAYS

Figure 10 SEL-587 Dimensions for Rack- and Panel-Mount Models

Specifications

General

Tightening Torque

Terminal Block:

Minimum:	8 in-lb (0.9 Nm)
Maximum:	12 in-lb (1.4 Nm)

Connectorized:

Minimum:	4.4 in-lb (0.5 Nm)
Maximum:	8.8 in-lb (1.0 Nm)

Terminal Connections

Terminals or stranded copper wire. Ring terminals are recommended. Minimum temperature rating of 105°C.

AC Current Inputs

5 A nominal:	15 A continuous, 500 A for 1 s, linear to 100 A symmetrical. 625 A for 1 cycle (sinusoidal waveform)
Burden:	0.16 VA at 5 A 1.15 VA at 15 A
1 A nominal:	3 A continuous, 100 A for 1 s, linear to 20 A symmetrical. 250 A for 1 cycle (sinusoidal waveform)
Burden:	0.06 VA at 1 A 0.18 VA at 3 A

Power Supply

Rated:	125/250 Vdc or Vac
Range:	85–350 Vdc or 85–264 Vac
Interruption:	100 ms @ 250 Vdc
Ripple:	5%
Burden:	<5.5 W
Rated:	48/125 Vdc or 125 Vac
Range:	36–200 Vdc or 85–140 Vac
Interruption:	100 ms @ 125 Vdc
Ripple:	5%
Burden:	<5.5 W
Rated:	24 Vdc
Range:	16–36 Vdc polarity dependent
Interruption:	25 ms @ 36 Vdc
Ripple:	5%
Burden:	<5.5 W

Note: Interruption and Ripple per IEC 255-11:1979.

Output Contacts

Conventional Terminal Blocks Option (Standard Outputs):

Make:	30 A
Carry:	6 A
1 s Rating:	100 A
MOV Protection:	270 Vac, 360 Vdc, 40 J
Pickup/Dropout Time:	<5 ms

Breaking Capacity (10000 operations):

24 V	0.75 A	L/R = 40 ms
48 V	0.50 A	L/R = 40 ms
125 V	0.30 A	L/R = 40 ms
250 V	0.20 A	L/R = 40 ms

Cyclic Capacity (2.5 cycle/second):

24 V	0.75 A	L/R = 40 ms
48 V	0.50 A	L/R = 40 ms
125 V	0.30 A	L/R = 40 ms
250 V	0.20 A	L/R = 40 ms

Plug-In Connectors Option (High Current Interrupting Outputs)

Make:	30 A
Carry:	6 A
MOV Protection:	330 Vdc, 40 J
Pickup Time:	<5 ms
Dropout Time:	<8 ms, typical

Breaking Capacity (10000 operations):

24 V	10 A	L/R = 40 ms
48 V	10 A	L/R = 40 ms
125 V	10 A	L/R = 40 ms
250 V	10 A	L/R = 20 ms

Cyclic Capacity (4 cycles in 1 second followed by 2 minutes idle for thermal dissipation):

24 V	10.0 A	L/R = 40 ms
48 V	10.0 A	L/R = 40 ms
125 V	10.0 A	L/R = 40 ms
250 V	10.0 A	L/R = 20 ms

Note: Do not use high current interrupting output contacts to switch ac control signals. These outputs are polarity dependent.

Note: Make per IEEE C37.90-1989; Breaking and Cyclic Capacity per IEC 255-0-20:1974.

Optoisolated Inputs

Conventional Terminal Blocks Option:

Jumper Selectable:

24 Vdc:	15–30 Vdc
48 Vdc:	30–60 Vdc
125 Vdc:	80–150 Vdc
250 Vdc:	150–300 Vdc

Level Sensitive:

48 Vdc:	Pickup 38.4–60 Vdc; Dropout 28.8 Vdc
110 Vdc:	Pickup 88–132 Vdc; Dropout 66 Vdc
125 Vdc:	Pickup 105–150 Vdc; Dropout 75 Vdc
220 Vdc:	Pickup 176–264 Vdc; Dropout 132 Vdc
250 Vdc:	Pickup 200–300 Vdc; Dropout 150 Vdc

Plug-In Connectors Option:

Standard (Non-Level Sensitive):

24 Vdc:	Pickup 15–30 Vdc
---------	------------------

Level Sensitive:

48 Vdc:	Pickup 38.4–60 Vdc; Dropout 28.8 Vdc
110 Vdc:	Pickup 88–132 Vdc; Dropout 66 Vdc
125 Vdc:	Pickup 105–150 Vdc; Dropout 75 Vdc
250 Vdc:	Pickup 200–300 Vdc; Dropout 150 Vdc

Note: Optoisolated inputs draw approx. 4 mA of current. All current ratings are at nominal input voltages.

Routine Dielectric Strength

AC Current Inputs:	2500 Vac for 10 s
Power Supply, Optoisolated Inputs, and Output Contacts:	3100 Vdc for 10 s

Frequency and Rotation

System Frequency:	60 or 50 Hz
Phase Rotation:	ABC or ACB

Communications Port Options

EIA-232 or EIA-485	
Baud:	300–38400

Time-Code Input

Relay accepts demodulated IRIG-B time-code input at Port 1.

Dimensions

See Figure 10.

Operating Temperature

–40° to +85°C (–40° to +185°F)

Weight

2.6 kg (5 lb, 12 oz)

Relay Shipping Weight

4 kg (9 lb)

Type Tests**Emissions**

*Generic Emissions, Heavy Industrial:	EN 50081-2:1994, Class A
*Generic Immunity, Heavy Industrial:	EN 50082-2:1995, Class A
*Radiated and Conducted Emissions:	EN 55011:1991, Class A
*Conducted Radio Frequency:	EN 61000-4-6:1996, ENV 50141:1996, 10 Vrms

Note: * = terminal block version only.

Radiated Radio Frequency (900 MHz with modulation):	ENV 50204:1996, 10 V/m
---	------------------------

Environmental Tests

Cold:	IEC 60068-2-1:1990 Test Ad; 16 hr at –40°C
Dry Heat:	IEC 60068-2-2:1974 Test Bd; 16 hr at +85°C
Damp Heat, Steady State:	IEC 60068-2-3:1969 96 hours at 40°C Relative humidity: 93%
Damp Heat, Cyclic:	IEC 60068-2-30:1980 Test Db; 55°C, 6 cycles, 95% humidity

Dielectric Strength and Impulse Tests

Dielectric:	IEC 60255-5:1977 IEEE C37.90-1989 2500 Vac on analogs, contact inputs, and contact outputs; 3100 Vdc on power supply; 2200 Vdc on EIA-485 communications port
Impulse:	IEC 60255-5:1977 0.5 J, 5000 V

Electrostatic Discharge Test

ESD:	IEC 60255-22-2:1996, Level 4
------	------------------------------

RFI and Interference Tests

1 MHz Burst Disturbance:	IEC 60255-22-1:1988 Class 3 (2500 V common and differential mode)
Fast Transient Disturbance:	IEEE C37.90.2-1995 IEC 60255-22-4:1992, Level 4 (4 kv @ 2.5 kHz on power supply; 2 kv @ 5 kHz on input/output, signal, data, and control lines)
Radiated Radio Frequency:	IEC 60255-22-3:1989 10 V/m
Surge Withstand:	IEEE C37.90.1-1989 3.0 kV oscillatory; 5.0 kV transient

Vibration and Shock Tests

Vibration:	IEC 60255-21-1:1988, Class 2
Shock and Bump:	IEC 60255-21-2:1988 Class 2
Seismic:	IEC 60255-21-3:1993 Class 2 (Conventional Terminal Block only)

Object Penetration

Object Penetration:	IEC 60529:1989 IP 3X
---------------------	-------------------------

Certifications

ISO: Relay designed and manufactured using ISO 9001 certified quality program.
UL 508 Industrial Control Equipment Standard for Safety (Conventional Terminal Block only)

Sampling

16 samples per power system cycle

Processing

Differential elements, optoisolated inputs and contact outputs are processed at 1/8 cycle. Overcurrent elements are processed at 1/4 cycle.

Metering Accuracy

Instantaneous Currents:	
5 A Model:	±2% ±0.10 A
1 A Model:	±2% ±0.02 A
Demand Currents:	
5 A Model:	±2% ±0.10 A
1 A Model:	±2% ±0.02 A

Differential Element

Unrestrained Pickup Range:	1–16 in per unit of TAP
Restrained Pickup Range:	0.1–1.0 in per unit of TAP
Pickup Accuracy (A secondary)	
5 A Model:	±5% ±0.10 A
1 A Model:	±5% ±0.02 A
Unrestrained Element Pickup Time	
(Min/Typ/Max):	0.8/1.1/2.0 cycles
Restrained Element (with harmonic blocking) Pickup Time	
(Min/Typ/Max):	1.6/1.7/2.3 cycles
Restrained Element (with harmonic restraint) Pickup Time (SEL-587-1)	
(Min/Typ/Max):	2.2/2.6/2.8 cycles

Harmonic Blocking Element

Pickup Range (% of fundamental):	5–100%
Pickup Accuracy (A secondary)	
5 A Model:	$\pm 5\% \pm 0.10$ A
1 A Model:	$\pm 5\% \pm 0.02$ A
Time Delay Accuracy:	$\pm 0.1\% \pm 0.25$ cycle

Timing Accuracy:	$\pm 4\% \pm 1.5$ cycles for current between 2 and 30 multiples of pickup. Curves operate on definite-time for current greater than 30 multiples of pickup or 16 times nominal.
Reset Characteristic:	Induction-disk reset emulation or 1-cycle linear reset.

Instantaneous/Definite-Time Overcurrent Elements (Winding)

Pickup Range (A secondary)	
5 A Model:	0.5–80.0 A
1 A Model:	0.1–16.0 A
Pickup Accuracy (A secondary)	
5 A Model:	$\pm 5\% \pm 0.10$ A
1 A Model:	$\pm 5\% \pm 0.02$ A
Pickup Time	
(Typ/Max):	0.75/1.20 cycles
Time Delay Range:	0–16,000 cycles
Time Delay Accuracy:	$\pm 0.1\% \pm 0.25$ cycle
Transient Overreach:	<5% of pickup

Time Overcurrent Elements (Winding and Combined Current)

Pickup Range (A secondary)	
5 A Model:	0.50–16.00 A
1 A Model:	0.10–3.20 A
Pickup Accuracy (A secondary)	
5 A Model:	$\pm 5\% \pm 0.10$ A
1 A Model:	$\pm 5\% \pm 0.02$ A
Pickup Time	
(Typ/Max):	0.75/1.20 cycles
Curve	
U1 =	U.S. Moderately Inverse
U2 =	U.S. Inverse
U3 =	U.S. Very Inverse
U4 =	U.S. Extremely Inverse
C1 =	IEC Class A (Standard Inverse)
C2 =	IEC Class B (Very Inverse)
C3 =	IEC Class C (Extremely Inverse)
C4 =	IEC Long-Time Inverse
Time-Dial Range	
US Curves:	0.50–15.00, .01 step
IEC Curves:	0.05–1.00, .01 step

© 1994–2007 by Schweitzer Engineering Laboratories, Inc. All rights reserved.

All brand or product names appearing in this document are the trademark or registered trademark of their respective holders. No SEL trademarks may be used without written permission. SEL products appearing in this document may be covered by US and Foreign patents.

Schweitzer Engineering Laboratories, Inc. reserves all rights and benefits afforded under federal and international copyright and patent laws in its products, including without limitation software, firmware, and documentation.

The information in this document is provided for informational use only and is subject to change without notice. Schweitzer Engineering Laboratories, Inc. has approved only the English language document.

This product is covered by the standard SEL 10-year warranty. For warranty details, visit www.selinc.com or contact your customer service representative.

SCHWEITZER ENGINEERING LABORATORIES

2350 NE Hopkins Court • Pullman, WA 99163-5603 USA

Phone: +1.509.332.1890 • Fax: +1.509.332.7990

Internet: www.selinc.com • E-mail: info@selinc.com

