

INSTRUCTION MANUAL

MOTOR PROTECTION RELAY

S2E21

TOSHIBA CORPORATION

REV 1

CONTENTS

	<u>Page</u>
1. INTRODUCTION	2
2. GENERAL SPECIFICATION	3
2.1 Rated Performance	4
2.2 Functions	5
2.3 Protection Curves	17
3. APPEARANCE AND CONFIGURATION	18
3.1 S2E21-C1A* (without DG)	18
3.2 S2E21-C1A[1 (with DG)	21
4. MOUNTING AND CONNECTION	27
4.1 Mounting	27
4.2 Connection	30
5. HANDLING	38
5.1 Installing Battery	38
5.2 Turning Power On	38
5.3 Basic Operation of Screen	39
5.4 Registration of ID	44
5.5 Menu	46
5.6 Measurement	47
5.7 Event	54
5.8 Setting	56
5.9 Testing	81
5.10 Failure Information	83
5.11 Handling of Memory Card	86
5.12 Directional Ground Unit (DG)	91
6. MAINTENANCE AND INSPECTION	92
6.1 Periodic Inspection	92
6.2 Troubleshooting	96
6.3 Bench Test	100
7. PROTECTIVE DETECTION SCHEME	105
7.1 Overload Unit	105
7.2 Locked Rotor Unit	109
7.3 Repetitive Starting	113
7.4 Detection of Starting Current and Starting Time	114
7.5 Detection of the Heating Time Constant and Cooling Time Constant	115
7.6 Setting Based on Fundamental Information	117
7.7 Setting For Reduce Voltage Starting	120
APPENDIX A	121

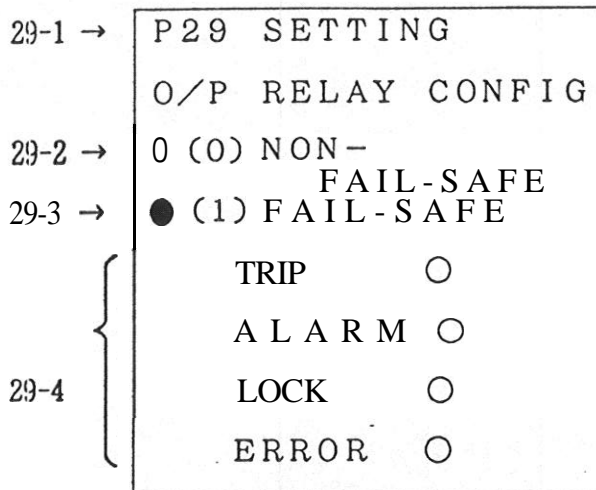

No.	Item	Description	State at delivery												
29-1	Setting	Sets the operation mode of the output relay.	—												
29-2	Energized-on operation (Non-fail-safe)	<p>The output relay is energized on operation. The state of output contact is shown below in the case of tripping.</p> <table border="1"> <thead> <tr> <th>State</th> <th>a-contact</th> <th>b-contact</th> </tr> </thead> <tbody> <tr> <td>Control supply not provided</td> <td>Open</td> <td>Closed</td> </tr> <tr> <td>Control supply provided</td> <td>Open</td> <td>Closed</td> </tr> <tr> <td>Trip</td> <td>Closed</td> <td>Open</td> </tr> </tbody> </table>	State	a-contact	b-contact	Control supply not provided	Open	Closed	Control supply provided	Open	Closed	Trip	Closed	Open	—
State	a-contact	b-contact													
Control supply not provided	Open	Closed													
Control supply provided	Open	Closed													
Trip	Closed	Open													

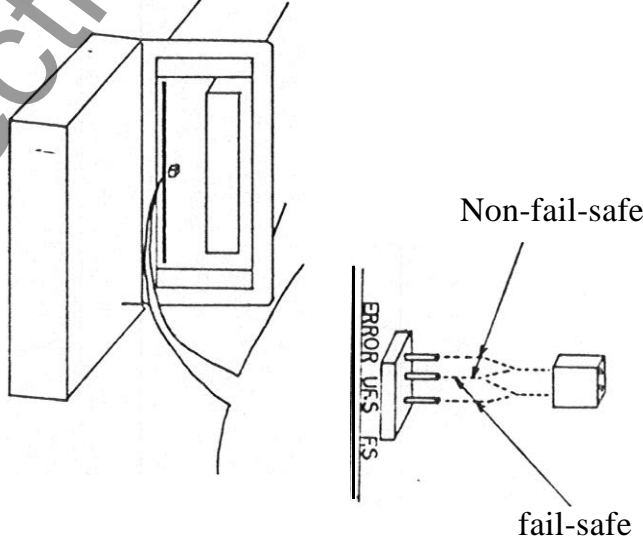
No.	Item	Description	State at delivery												
19-3	Continuously energized (fail safe)	<p>The output relay is energized at normal condition. The state of output contact is shown below in the case of tripping.</p> <table border="1" data-bbox="457 499 902 884"> <thead> <tr> <th data-bbox="457 499 565 537">State</th> <th data-bbox="565 499 739 537">a-contact</th> <th data-bbox="739 499 902 537">b-contact</th> </tr> </thead> <tbody> <tr> <td data-bbox="457 537 565 653">Control supply not provided</td> <td data-bbox="565 537 739 575">Open</td> <td data-bbox="739 537 902 575">Closed</td> </tr> <tr> <td data-bbox="457 705 565 800">Control supply provided</td> <td data-bbox="565 705 739 743">Closed</td> <td data-bbox="739 705 902 743">Open</td> </tr> <tr> <td data-bbox="457 842 565 879">Trip</td> <td data-bbox="565 842 739 879">Open</td> <td data-bbox="739 842 902 879">Closed</td> </tr> </tbody> </table>	State	a-contact	b-contact	Control supply not provided	Open	Closed	Control supply provided	Closed	Open	Trip	Open	Closed	-
State	a-contact	b-contact													
Control supply not provided	Open	Closed													
Control supply provided	Closed	Open													
Trip	Open	Closed													
19-4	Setting	<p>Selects between continuously energized and energized-on-operation for 3 outputs-trip, alarm, and lock.</p> <p>Setting is made by moving the cursor to this position and entering "0" or "1. "</p> <p>The setting of the error output is made in hardware.</p> 	<p>TRIP } ○</p> <p>ALARM } ○</p> <p>LOCK } ○</p> <p>ERROR: ○</p>												

30-1 →

P30 SETTING		
RY O/P SEL.		
- (0) NOP.	○ (1) OPE.	
	ALM	TRP
OL		0
OC	-	
UC		
INST		
UB	-	-
L. R		
OCG		
RTD		
SPARE1	-	
SPARE2	↑	

← 30-3

30-2

No.	Item	Description	State at delivery
30-1	jetting	Sets the operation condition for the output relay.	—
30-2	Alarm output	<p>Selects a unit that drives the alarm output relay when an alarm is detected.</p> <p>Enter either "0" (not operate) or "1" (operate).</p> <p>The output is an ORed output of alarm detections from the unit that drives the alarm output relay.</p> <p>Locked-rotor has no alarm. But it is detected as an overload (OL) alarm instead.</p>)

No.	Item	Description	State at delivery
30-3	Trip	<p>Specifies a unit that drives the trip output relay when a trip is detected.</p> <p>Enter either "0" (not operate) or "1" (operate).</p> <p>The output is an ORed output of trip detections from the unit that drives the trip output relay.</p>	OL: 1 Others:

31-1 → P 3 1 S E T T I N G

31-2 → A T D O / P = 2

(0 = O F F 7 = R T D 1
 1 = I R 8 = R T D 2
 2 = I S 9 = R T D 3
 3 = I T 1 0 = R T D 4
 4 = I A V 1 1 = R T D 5
 5 = θ S 1 2 = R T D 6
 6 = θ R 1 3 = R T D 7
 1 4 = R T D 8
 1 5 = I O)

No.	Item	Description	State at delivery
31-1	Setting	Selects an analog transducer output.	—
31-2	Ana log transducer output	Selects a measuring unit that outputs data to the analog transducer.	0

transducer output	4 mA ~ 20 mA
IR IS IT IAV	0 A ~ CT RATIO (No. 20-2)
θ S	0 °C ~ θ SM (No. 21-6)
θ R	0 °C ~ 200 °C

transducer output	4mA ~ 20 mA
RTD1 RTD2 RTD3 RTD4 RTD5 RTD6 RTD8	-20°C ~ 200°C
10	0A ~ ZCT RATIO (No. 20-3)

```

32-1 → P 3 2  S E T T I N G
32-2 →   R T D 1      0
          R T D 2      0
          R T D 3      0
          R T D 4      0
          R T D 5      0
          R T D 6      0
          R T D 7      0
          R T D 8      0
          ( 0 = O F F
            1 = P t 1 0 0 Ω
            2 = P t 1 0 0 Ω : J I S
            4 = N i 1 2 0 Ω      )
    
```

No.	Item	Description	State at delivery
32-1	Setting	Sets the kind of RTD.	—
32-2	Kind of RTD	<p>RTD1 to RTD8: Selects the corresponding RTD type. Different RTD types can be selected on one relay.</p> <p>Example: RTD1 to RTD6 can be Pt100Ω, and RTD7 & RTD8 can be Ni120Ω on one individual relay.</p> <p>Set to 0 (OFF) those channels that are not used.</p>	0

33-1 →		P33 SETTING			
33-2 →		PRE ALM	TRP	RE SET	33-3
		RTD1	100	100	100
		RTD2	100	100	100
		RTD3	100	100	100
		RTD4	100	100	100
		RTD5	100	100	100
		RTD6	100	100	100
		RTD7	100	100	100
		RTD8	100	100	100
		UNIT : °C			33-4

No.	Item	Description	State at delivery
33-1	Setting	Sets the alarm, trip and reset levels for the RTD's.	—
33-2	Alarm level	Sets alarm detection temperature for each RTD. Setting range: 0 ~ 200 °C	100 °C
33-3	Trip level	Sets trip detection temperature for each RTD. Setting range: 0 ~ 200 °C	100 °C
33-4	Reset level	Sets a reset temperature for each RTD. After the temperature goes below the reset level, the S2E21 can then be reset. Setting range: 0 ~ 200 °C	100 °C

34-1 →	P 3 4 S E T T I N G	
	* A U T O L E A R N I N G *	
	<input type="radio"/> (0)	OFF
	<input checked="" type="radio"/> (1)	ON
34-2 →	1 s t	0
34-3 →	T s t	0
34-4 →	TR	0
34-5 →	TD	0

No.	Item	Description	State at de I i very
34-1	Setting	Sets whether or not automatic detection is needed.	—
34-2	Starting current	<p>Automatically detects the starting current and specifies whether or not the detected value is taken as the starting current setting. Enter either 0 (OFF) or 1 (ON).</p> <p>When 0 (OFF) is entered, the detected starting current is displayed (P4) but the input value, not the detected value, is used as the setting value in the starting current setting (P25).</p> <p>When 1 (ON) is entered, the detected starting current is displayed (P4) and also taken as the setting value in the starting current setting (P25).</p>	○

No.	Item	Description	State at delivery
34-3	starting time	<p>Automatically detects the starting time and specifies whether or not the detected starting time is used as the setting value. Enter either 0 (OFF) or 1 (ON).</p> <p>When 0 (OFF) is entered, the starting time is displayed (P4) but the input setting value, not the detected value, is used as the setting value in the starting time setting (P25).</p> <p>When 1 (ON) is entered, the detected starting time is displayed (P4) and also taken as the setting value in the starting time setting (P25).</p>	0
34-4	Heating time constant	<p>Automatically detects the heating time constant and specifies whether or not the detected value is taken as the heating time constant setting.</p> <p>When 1 (ON) is entered, the heating time constant is automatically detected and the detected value is taken as the setting value.</p> <p>Upon completion of detection, this setting automatically turns off.</p> <p>Automatic detection requires input of RTD1 to RTD3 for stator temperature, and RTD8 for ambient temperature.</p>	0

No.	Item	Description	State at delivery
14-5	Cooling time constant	<p>Automatically detects the cooling time constant and specifies whether or not the detected value is taken as the cooling time constant setting.</p> <p>When 1 (ON) is entered, the cooling time constant is automatically detected and the detected value is taken as the setting value.</p> <p>Upon completion of detection, this setting automatically turns off.</p> <p>Automatic detection requires input of RTD1 to RTD3, and RTD8 for ambient temperature.</p>	○

```

35-1 → P 3 5  S E T T I N G

Clear      data      0

35-2 {  (1 : ALL
        (2 : θ S , θ R
        (3 : I MAX
        (4 : N s t
        (5 : T t r u n
        (6 : LEARNED TR
        (7 : LEARNED TD
        (8 : MAX STARTS)
    
```

No.	Item	Description	State at delivery
35-1	Setting	Clears accumulated data and held data.	—
35-2	Clearing	<p>Entering the numbers of items whose data you want cleared causes the corresponding data to be cleared.</p> <p>Example:</p> <ol style="list-style-type: none"> 1. Data may be required to be reset (cleared) due to a new motor installation. 2. Temperature data only (θS or θR) may be required to be reset for an emergency restart. Caution should be taken in resetting this data. Motor damage may result. 	

5.9 Testing

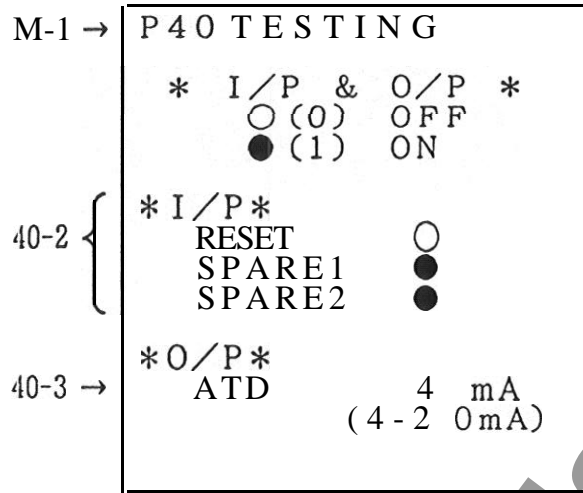

No.	Item	Description	State at delivery
40-1	Testing	Perform tests on the input/output circuit.	—
40-2	Input	Displays the state of contact input from the terminal block. Displays ● when there is an input: and Displays 0 when there is no input. The 3-phase input and zero-phase input are checked with the current value displayed on P2.	—

No.	Item	Description	State at delivery
40-3	Analog transducer	<p>Changes the output of the analog transducer.</p> <p>Press [EXE] key. The cursor appears, and enter a current value (4-20 mA) to be output from the analog transducer.</p> <p>The output current is checked externally.</p>	-

5.10 Failure Information

```

50-1 → P 5 0   O L   T R I P
50-2 →   0 7 / 1 7   9 8 : 2 9

      {
50-3 {   I R                               A
        I S 1 2 8   1 3 0                 A
        I T                               A
        I O   1 3 2   0                   A
        e S   6 0 . 0                       °C
        θ R 2 3 . 2                           °C
        U B                               %
    
```

No.	Item	Description	State at delivery
50-1	Trip information	Displays information at the date and time of the latest current-associated trip. Cause of trip is displayed.	—
50-2	Time	Displays the date and time at which the trip occurred.	—
50-3	information	Displays 3-phase current, zero-phase current, temperature rise and unbalance factor at the trip. ..	—

51-1 →	P 5 1	TRIP
51-2 →	00/00 00 : 00	
51-3 {	RTD 1	0 c
	RTD 2	00 c
	RTD 3	00 c
	RTD 4	00 c
	RTD 5	00 c
	RTD 6	00 c
	RTD 7	00 c
	RTD 8	0 c

No.	Item	Description	State at delivery
51-1	Trip information	Displays information at the date and time of the latest trip. RTD number, that has tripped is displayed.	—
51-2	Time	Displays the date and time at which the trip occurred.	—
51-3	Information	Displays temperature of each RTD at trip.	—

<p>P52 TRIP CURRENT 00/00 00:00</p> <p>S E C I R (A) I S (A)</p> <p>- 1 0 0</p> <p>- 2 0 0</p> <p>- 3 0 0</p> <p>- 4 0 0</p> <p>- 5 0 0</p> <p>- 6 0 0</p> <p>- 7 0 0</p> <p>- 8 0 0</p> <p>- 9 0 0</p> <p>-10 0 0</p>	<p>←52-1 53-1-r ←52-2 53-2→</p> <p>←52-3 53-3→</p>	<p>P53 TRIP CURRENT 00/00 00:00</p> <p>S E C I T (A) I O (A)</p> <p>- 1 0 0</p> <p>- 2 0 0</p> <p>- 3 0 0</p> <p>- 4 0 0</p> <p>- 5 0 0</p> <p>- 6 0 0</p> <p>- 7 0 0</p> <p>- 8 0 0</p> <p>- 9 0 0</p> <p>-10 0 0</p>
---	--	---

No.	Item	Description	State at delivery
52-1 53-1	Trip current trend	Displays the current trend immediately before the trip	—
52-2 53-2	Time	Displays the date time at which the trip occurred.	—
52-3 53-3	Current trend	Displays 10 seconds of 1 second interval current trend before trip. Current of R-phase and S-phase are displayed on P52; and current of T-phase and zero-phase are displayed on P53.	—

5.11 Handling of Memory Card

The S2E21s each have a dedicated memory card, which is used for backup of S2E21 settings and as information media for the monitor system (purchased separately) that includes personal computers. The specifications of the memory card are shown in Table 5.

5.11.1 Sack up of Setting

The memory card is utilized as a backup of the setting of the S2E21.

Procedure for backup

1. Cancel the write-protect for the memory card.
(See 5.11.3 (2).)
2. Insert the memory card into the S2E21.
(See 5.11.3 (3).)
3. Initialize the memory card.
(See 5.8 P27.)
4. Store the contents of setting into the memory card.
(See 5.8 P27.)
5. Turn on the write-protect for the memory card.
(See 5.11.3 (2).)

The memory card uses S-RAM card with a battery backup that prevents the contents of the backup from being lost when you pull the memory card from the S2E21. The battery backup also allows the memory card to be inserted or withdrawn during the operation of the S2E21.

CAUTION: Removing the memory card from the S2E21 and storing it alone may result in the loss of the backed-up contents when the backup battery is exhausted. The memory card must be left inserted in the S2E21.

Procedure for loading the backed-up settings of the memory card into the S2E21.

1. Register the MACH. ID and PASS ID of the S2E21.
(MACH. ID and PASS ID must be the same as those when the settings were backed up in the memory card.)
(See 5.3.3. 5.4.)
2. Insert the memory card into the S2E21.
(See 5.11.3 (3).)
3. Load the backed-up contents from the memory card into the S2E21.

The contents of settings backed up by the memory card are those stored by the above backup procedure. After this, when the settings of the S2E21 are changed, the contents of the memory card do not automatically change. You are required to perform the store operation again.

Prior to the loading of the backed-up settings, comparison is made of the MACH. ID and PASS ID between the memory card and the S2E21. When these ID numbers do not agree, the backed-up settings will not be loaded into the S2E21.

5.11.2 Memory Card As Information Media

The memory card may be used as information media for the monitor system including personal computers and for the S2E21.

For detail, see the manual for the monitor system.

Table 4 Memory Card Specifications

Item		Description
Manufacturer		Toshiba
Type		MCA 5101BAA
Memory type		S-RAM
Capacity		32 kbytes
Scheme		Memory bus scheme
Pin number		40 pins
Battery	type	Lithium coin battery (3 V)
Battery life	Not in relay	Approx. 2 years
	Inserted in relay	Greater than 10 years W/control power on relay
		Approx. 2 years W/no power to relay

5.11.3 Handling of Memory Card

The memory card should be handled as follows.

(1) Installing battery:

- 1) Open the battery holder cover of the memory card with the screwdriver supplied.
- 2) Place the attached battery in the battery holder, with the positive polarity (+) facing up.
- 3) Close the battery holder cover in the process reverse to step 1).

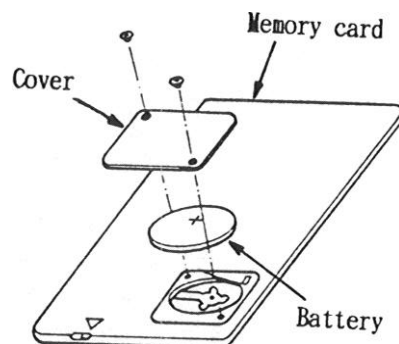

(2) Write-protecting the memory card:

The memory card is provided with a write-protect switch for preventing inadvertent writing. Turn on the write-protect switch (to set the write-protect) except when storing the data into the memory card.

To set the write-protect:

Move the write-protect switch to the right side (to align with the mark "▽"). This disables writing into the memory card.

To cancel the write-protect:

Move the write-protect switch to the left side (away from the mark "▽"). This enables writing into the memory card.

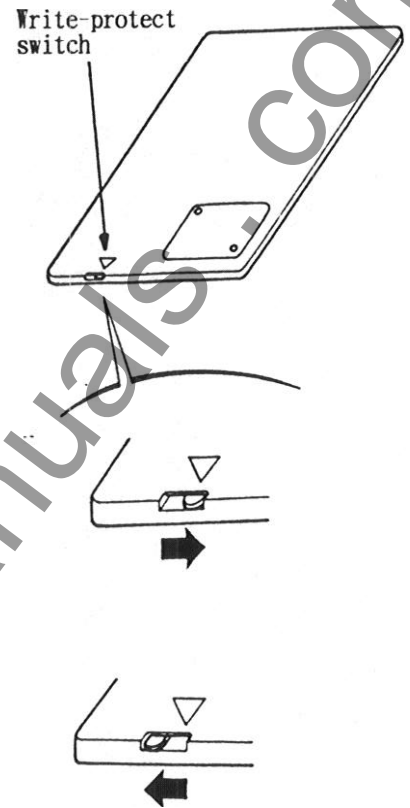

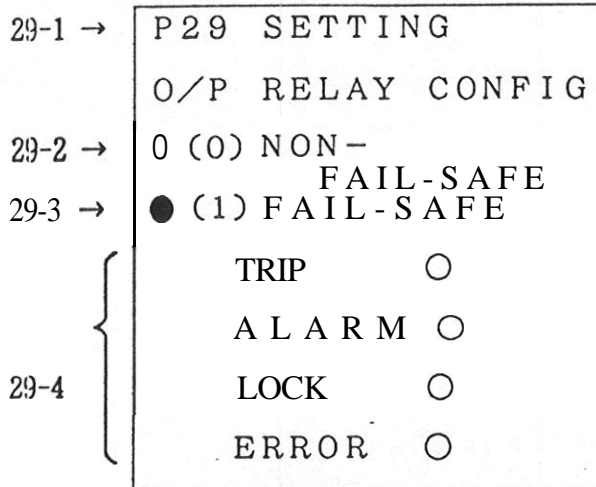

No.	Item	Description	State at delivery												
29-1	Setting	Sets the operation mode of the output relay.	—												
29-2	Energized-on operation (Non-fail-safe)	<p>The output relay is energized on operation. The state of output contact is shown below in the case of tripping.</p> <table border="1"> <thead> <tr> <th>State</th> <th>a-contact</th> <th>b-contact</th> </tr> </thead> <tbody> <tr> <td>Control supply not provided</td> <td>Open</td> <td>Closed</td> </tr> <tr> <td>Control supply provided</td> <td>Open</td> <td>Closed</td> </tr> <tr> <td>Trip</td> <td>Closed</td> <td>Open</td> </tr> </tbody> </table>	State	a-contact	b-contact	Control supply not provided	Open	Closed	Control supply provided	Open	Closed	Trip	Closed	Open	—
State	a-contact	b-contact													
Control supply not provided	Open	Closed													
Control supply provided	Open	Closed													
Trip	Closed	Open													

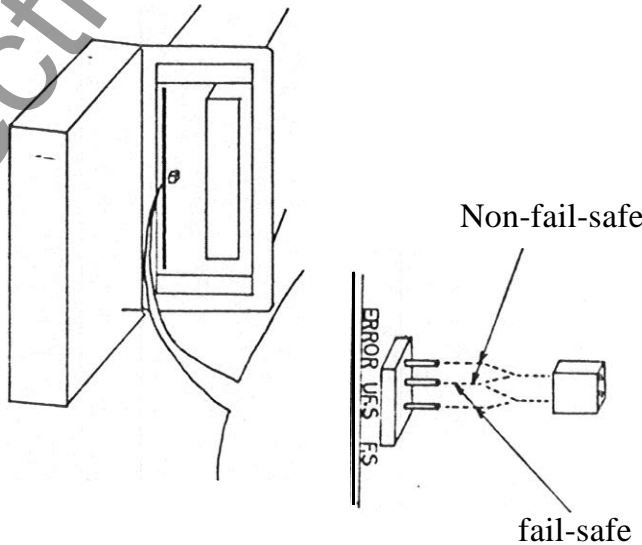
No.	Item	Description	State at delivery												
19-3	Continuously energized (fail safe)	<p>The output relay is energized at normal condition. The state of output contact is shown below in the case of tripping.</p> <table border="0" style="margin-left: auto; margin-right: auto;"> <tr> <td style="text-align: center;"><u>State</u></td> <td style="text-align: center;"><u>a-contact</u></td> <td style="text-align: center;"><u>b-contact</u></td> </tr> <tr> <td>Control supply not provided</td> <td style="text-align: center;">Open</td> <td style="text-align: center;">Closed</td> </tr> <tr> <td>Control supply provided</td> <td style="text-align: center;">Closed</td> <td style="text-align: center;">Open</td> </tr> <tr> <td>Trip</td> <td style="text-align: center;">Open</td> <td style="text-align: center;">Closed</td> </tr> </table>	<u>State</u>	<u>a-contact</u>	<u>b-contact</u>	Control supply not provided	Open	Closed	Control supply provided	Closed	Open	Trip	Open	Closed	-
<u>State</u>	<u>a-contact</u>	<u>b-contact</u>													
Control supply not provided	Open	Closed													
Control supply provided	Closed	Open													
Trip	Open	Closed													
19-4	Setting	<p>Selects between continuously energized and energized-on-operation for 3 outputs-trip, alarm, and lock.</p> <p>Setting is made by moving the cursor to this position and entering "0" or "1. "</p> <p>The setting of the error output is made in hardware.</p> 	<p>TRIP } ○</p> <p>ALARM } ○</p> <p>LOCK } ○</p> <p>ERROR: ○</p>												

30-1 →

P30 SETTING		
RY O/P SEL.		
- (0) NOP.	○ (1) OPE.	
	ALM	TRP
OL		0
OC	-	
UC		
INST		
UB	-	-
L. R		
OCG		
RTD		
SPARE1	-	
SPARE2	↑	

← 30-3

30-2

No.	Item	Description	State at delivery
30-1	jetting	Sets the operation condition for the output relay.	—
30-2	Alarm output	<p>Selects a unit that drives the alarm output relay when an alarm is detected.</p> <p>Enter either "0" (not operate) or "1" (operate).</p> <p>The output is an ORed output of alarm detections from the unit that drives the alarm output relay.</p> <p>Locked-rotor has no alarm. But it is detected as an overload (OL) alarm instead.</p>)

No.	Item	Description	State at delivery
30-3	Trip	<p>Specifies a unit that drives the trip output relay when a trip is detected.</p> <p>Enter either "0" (not operate) or "1" (operate).</p> <p>The output is an ORed output of trip detections from the unit that drives the trip output relay.</p>	OL: 1 Others:

31-1 → P 3 1 S E T T I N G

31-2 → A T D O / P = 2

(0 = O F F 7 = R T D 1
 1 = I R 8 = R T D 2
 2 = I S 9 = R T D 3
 3 = I T 1 0 = R T D 4
 4 = I A V 1 1 = R T D 5
 5 = θ S 1 2 = R T D 6
 6 = θ R 1 3 = R T D 7
 1 4 = R T D 8
 1 5 = I O)

No.	Item	Description	State at delivery
31-1	Setting	Selects an analog transducer output.	—
31-2	Ana log transducer output	Selects a measuring unit that outputs data to the analog transducer.	0

transducer output	4 mA ~ 20 mA
IR IS IT IAV	0 A ~ CT RATIO (No. 20-2)
θ S	0 °C ~ θ SM (No. 21-6)
θ R	0 °C ~ 200 °C

transducer output	4mA ~ 20 mA
RTD1 RTD2 RTD3 RTD4 RTD5 RTD6 RTD8	-20°C ~ 200°C
10	0A ~ ZCT RATIO (No. 20-3)

```

32-1 → P 3 2  S E T T I N G
32-2 →   R T D 1      0
          R T D 2      0
          R T D 3      0
          R T D 4      0
          R T D 5      0
          R T D 6      0
          R T D 7      0
          R T D 8      0
          ( 0 = O F F
            1 = P t 1 0 0 Ω
            2 = P t 1 0 0 Ω : J I S
            4 = N i 1 2 0 Ω      )
    
```

No.	Item	Description	State at delivery
32-1	Setting	Sets the kind of RTD.	—
32-2	Kind of RTD	<p>RTD1 to RTD8: Selects the corresponding RTD type. Different RTD types can be selected on one relay.</p> <p>Example: RTD1 to RTD6 can be Pt100Ω, and RTD7 & RTD8 can be Ni120Ω on one individual relay.</p> <p>Set to 0 (OFF) those channels that are not used.</p>	0

P33 SETTING			
	PRE ALM	TRP	RE SET
RTD1	100	100	100
RTD2	100	100	100
RTD3	100	100	100
RTD4	100	100	100
RTD5	100	100	100
RTD6	100	100	100
RTD7	100	100	100
RTD8	100	100	100
UNIT : °C			

No.	Item	Description	State at delivery
33-1	Setting	Sets the alarm, trip and reset levels for the RTD's.	—
33-2	Alarm level	Sets alarm detection temperature for each RTD. Setting range: 0 ~ 200 °C	100 °C
33-3	Trip level	Sets trip detection temperature for each RTD. Setting range: 0 ~ 200 °C	100 °C
33-4	Reset level	Sets a reset temperature for each RTD. After the temperature goes below the reset level, the S2E21 can then be reset. Setting range: 0 ~ 200 °C	100 °C

34-1 →	P 3 4 S E T T I N G	
	* A U T O L E A R N I N G *	
	<input type="radio"/> (0)	OFF
	<input checked="" type="radio"/> (1)	ON
34-2 →	1 s t	0
34-3 →	T s t	0
34-4 →	TR	0
34-5 →	TD	0

No.	Item	Description	State at de I i very
34-1	Setting	Sets whether or not automatic detection is needed.	—
34-2	Starting current	<p>Automatically detects the starting current and specifies whether or not the detected value is taken as the starting current setting. Enter either 0 (OFF) or 1 (ON).</p> <p>When 0 (OFF) is entered, the detected starting current is displayed (P4) but the input value, not the detected value, is used as the setting value in the starting current setting (P25).</p> <p>When 1 (ON) is entered, the detected starting current is displayed (P4) and also taken as the setting value in the starting current setting (P25).</p>	○

No.	Item	Description	State at delivery
34-3	starting time	<p>Automatically detects the starting time and specifies whether or not the detected starting time is used as the setting value. Enter either 0 (OFF) or 1 (ON).</p> <p>When 0 (OFF) is entered, the starting time is displayed (P4) but the input setting value, not the detected value, is used as the setting value in the starting time setting (P25).</p> <p>When 1 (ON) is entered, the detected starting time is displayed (P4) and also taken as the setting value in the starting time setting (P25).</p>	0
34-4	Heating time constant	<p>Automatically detects the heating time constant and specifies whether or not the detected value is taken as the heating time constant setting.</p> <p>When 1 (ON) is entered, the heating time constant is automatically detected and the detected value is taken as the setting value.</p> <p>Upon completion of detection, this setting automatically turns off.</p> <p>Automatic detection requires input of RTD1 to RTD3 for stator temperature, and RTD8 for ambient temperature.</p>	0

No.	Item	Description	State at delivery
14-5	Cooling time constant	<p>Automatically detects the cooling time constant and specifies whether or not the detected value is taken as the cooling time constant setting.</p> <p>When 1 (ON) is entered, the cooling time constant is automatically detected and the detected value is taken as the setting value.</p> <p>Upon completion of detection, this setting automatically turns off.</p> <p>Automatic detection requires input of RTD1 to RTD3, and RTD8 for ambient temperature.</p>	○

```

35-1 → P 3 5  S E T T I N G

        C l e a r      d a t a      0

        {
35-2   ( 1 :  A L L
        ( 2 :  θ S ,  θ R
        ( 3 :  I M A X
        ( 4 :  N s t
        ( 5 :  T t r u n
        ( 6 :  L E A R N E D  T R
        ( 7 :  L E A R N E D  T D
        ( 8 :  M A X  S T A R T S )
    
```

No.	Item	Description	State at delivery
35-1	Setting	Clears accumulated data and held data.	—
35-2	Clearing	<p>Entering the numbers of items whose data you want cleared causes the corresponding data to be cleared.</p> <p>Example:</p> <ol style="list-style-type: none"> 1. Data may be required to be reset (cleared) due to a new motor installation. 2. Temperature data only (θS or θR) may be required to be reset for an emergency restart. Caution should be taken in resetting this data. Motor damage may result. 	

5.9 Testing

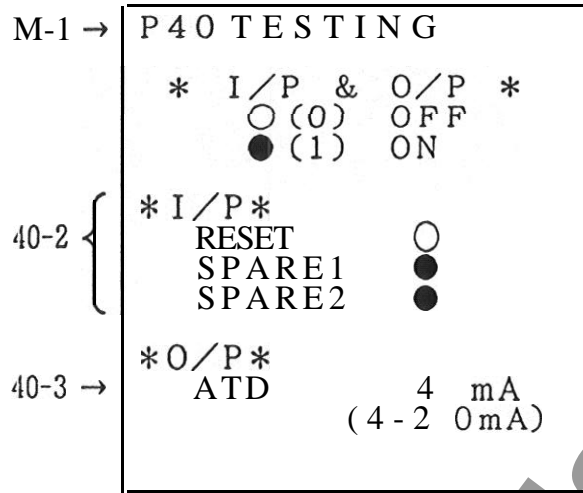

No.	Item	Description	State at delivery
40-1	Testing	Perform tests on the input/output circuit.	—
40-2	Input	Displays the state of contact input from the terminal block. Displays ● when there is an input: and Displays 0 when there is no input. The 3-phase input and zero-phase input are checked with the current value displayed on P2.	—

No.	Item	Description	State at delivery
40-3	Analog transducer	<p>Changes the output of the analog transducer.</p> <p>Press [EXE] key. The cursor appears, and enter a current value (4-20 mA) to be output from the analog transducer.</p> <p>The output current is checked externally.</p>	-

5.10 Failure Information

```

50-1 → P 5 0   O L   T R I P
50-2 →   0 7 / 1 7   9 8 : 2 9

      {
50-3 {   I R                               A
        I S 1 2 8   1 3 0                 A
        I T                               A
        I O      1 3 2   0                 A
        e S   6 0 . 0                       °C
        θ R  2 3 . 2                           °C
        U B                               %
    
```

No.	Item	Description	State at delivery
50-1	Trip information	Displays information at the date and time of the latest current-associated trip. Cause of trip is displayed.	—
50-2	Time	Displays the date and time at which the trip occurred.	—
50-3	information	Displays 3-phase current, zero-phase current, temperature rise and unbalance factor at the trip. ..	—

```

51-1 → P51          TRIP
51-2 → 00/00 00 : 00

      {
51-3 {   RTD 1          0 0000000
      {   RTD 2          0 0000000
      {   RTD 3          0 0000000
      {   RTD 4          0 0000000
      {   RTD 5          0 0000000
      {   RTD 6          0 0000000
      {   RTD 7          0 0000000
      {   RTD 8          0 0000000

```

No.	Item	Description	State at delivery
51-1	Trip information	Displays information at the date and time of the latest trip. RTD number, that has tripped is displayed.	—
51-2	Time	Displays the date and time at which the trip occurred.	—
51-3	Information	Displays temperature of each RTD at trip.	—

<p>P52 TRIP CURRENT 00/00 00:00</p> <p>S E C I R (A) I S (A)</p> <p>- 1 0 0</p> <p>- 2 0 0</p> <p>- 3 0 0</p> <p>- 4 0 0</p> <p>- 5 0 0</p> <p>- 6 0 0</p> <p>- 7 0 0</p> <p>- 8 0 0</p> <p>- 9 0 0</p> <p>-10 0 0</p>	<p>←52-1 53-1-r ←52-2 53-2→</p> <p>←52-3 53-3→</p>	<p>P53 TRIP CURRENT 00/00 00:00</p> <p>S E C I T (A) I O (A)</p> <p>- 1 0 0</p> <p>- 2 0 0</p> <p>- 3 0 0</p> <p>- 4 0 0</p> <p>- 5 0 0</p> <p>- 6 0 0</p> <p>- 7 0 0</p> <p>- 8 0 0</p> <p>- 9 0 0</p> <p>-10 0 0</p>
---	--	---

No.	Item	Description	State at delivery
52-1 53-1	Trip current trend	Displays the current trend immediately before the trip	—
52-2 53-2	Time	Displays the date time at which the trip occurred.	—
52-3 53-3	Current trend	Displays 10 seconds of 1 second interval current trend before trip. Current of R-phase and S-phase are displayed on P52; and current of T-phase and zero-phase are displayed on P53.	—

5.11 Handling of Memory Card

The S2E21s each have a dedicated memory card, which is used for backup of S2E21 settings and as information media for the monitor system (purchased separately) that includes personal computers. The specifications of the memory card are shown in Table 5.

5.11.1 Sack up of Setting

The memory card is utilized as a backup of the setting of the S2E21.

Procedure for backup

1. Cancel the write-protect for the memory card.
(See 5.11.3 (2).)
2. Insert the memory card into the S2E21.
(See 5.11.3 (3).)
3. Initialize the memory card.
(See 5.8 P27.)
4. Store the contents of setting into the memory card.
(See 5.8 P27.)
5. Turn on the write-protect for the memory card.
(See 5.11.3 (2).)

The memory card uses S-RAM card with a battery backup that prevents the contents of the backup from being lost when you pull the memory card from the S2E21. The battery backup also allows the memory card to be inserted or withdrawn during the operation of the S2E21.

CAUTION: Removing the memory card from the S2E21 and storing it alone may result in the loss of the backed-up contents when the backup battery is exhausted. The memory card must be left inserted in the S2E21.

Procedure for loading the backed-up settings of the memory card into the S2E21.

1. Register the MACH. ID and PASS ID of the S2E21.
(MACH. ID and PASS ID must be the same as those when the settings were backed up in the memory card.)
(See 5.3.3. 5.4.)
2. Insert the memory card into the S2E21.
(See 5.11.3 (3).)
3. Load the backed-up contents from the memory card into the S2E21.

The contents of settings backed up by the memory card are those stored by the above backup procedure. After this, when the settings of the S2E21 are changed, the contents of the memory card do not automatically change. You are required to perform the store operation again.

Prior to the loading of the backed-up settings, comparison is made of the MACH. ID and PASS ID between the memory card and the S2E21. When these ID numbers do not agree, the backed-up settings will not be loaded into the S2E21.

5.11.2 Memory Card As Information Media

The memory card may be used as information media for the monitor system including personal computers and for the S2E21.

For detail, see the manual for the monitor system.

Table 4 Memory Card Specifications

Item		Description
Manufacturer		Toshiba
Type		MCA 5101BAA
Memory type		S-RAM
Capacity		32 kbytes
Scheme		Memory bus scheme
Pin number		40 pins
Battery	type	Lithium coin battery (3 V)
Battery life	Not in relay	Approx. 2 years
	Inserted in relay	Greater than 10 years W/control power on relay
		Approx. 2 years W/no power to relay

5.11.3 Handling of Memory Card

The memory card should be handled as follows.

(1) Installing battery:

- 1) Open the battery holder cover of the memory card with the screwdriver supplied.
- 2) Place the attached battery in the battery holder, with the positive polarity (+) facing up.
- 3) Close the battery holder cover in the process reverse to step 1).

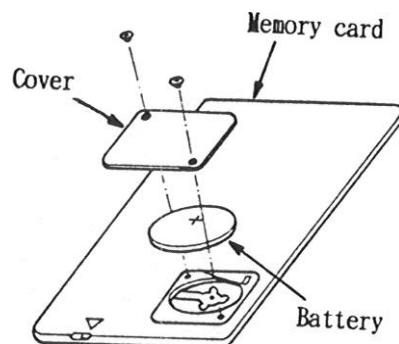

(2) Write-protecting the memory card:

The memory card is provided with a write-protect switch for preventing inadvertent writing. Turn on the write-protect switch (to set the write-protect) except when storing the data into the memory card.

To set the write-protect:

Move the write-protect switch to the right side (to align with the mark "▽"). This disables writing into the memory card.

To cancel the write-protect:

Move the write-protect switch to the left side (away from the mark "▽"). This enables writing into the memory card.

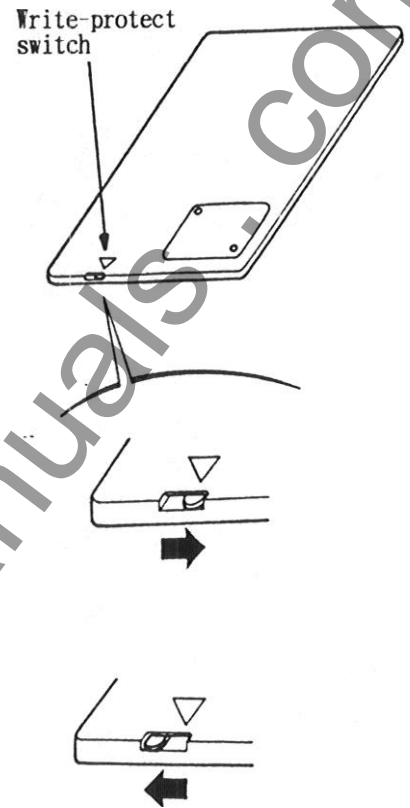

- (3) Inserting and withdrawing the memory card to/from the S2E21:

Inserting the memory card:

Push forward the right end of the door of the display control section to open it and then perform the following.

- 1) Insert the memory card into the guide with the upper surface of the card facing toward the right;
- 2) Be sure to insert the memory card to the full stop.

- 3) When inserted fully, the memory card end becomes aligned with the front and of the printed circuit board.

If the memory card still projects from the board (card is not fully inserted), push it further to the complete stop.

Withdrawing the memory card:

Reverse the insertion process.

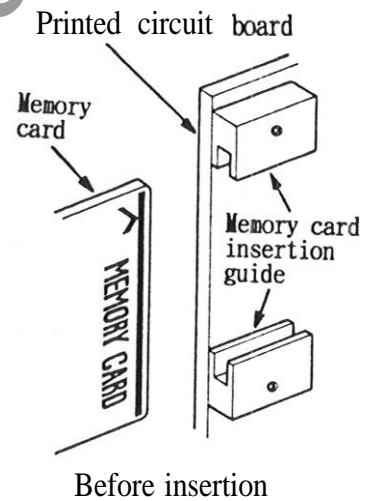
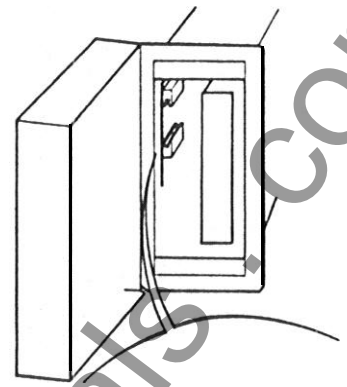

Before insertion

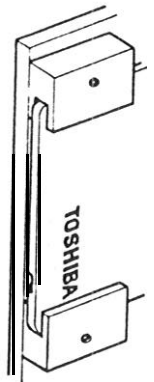

After insertion (fully inserted)

5.12 Directional Ground Unit (DG)

The directional ground unit has three kinds of directional ground modules. For detail, see the next manuals.

- 1) 6F9E0107 for ungrounded system
- 2) 6F9E0108 for 10 A grounded system
- 3) 6F9E0109 for capacitor-voltage-division type

The terminal numbers 47 to 66 in the above manuals are read as D47 to D66 for S2E21 in this manual.

The front external views of the three directional ground modules are shown in Figure 14.

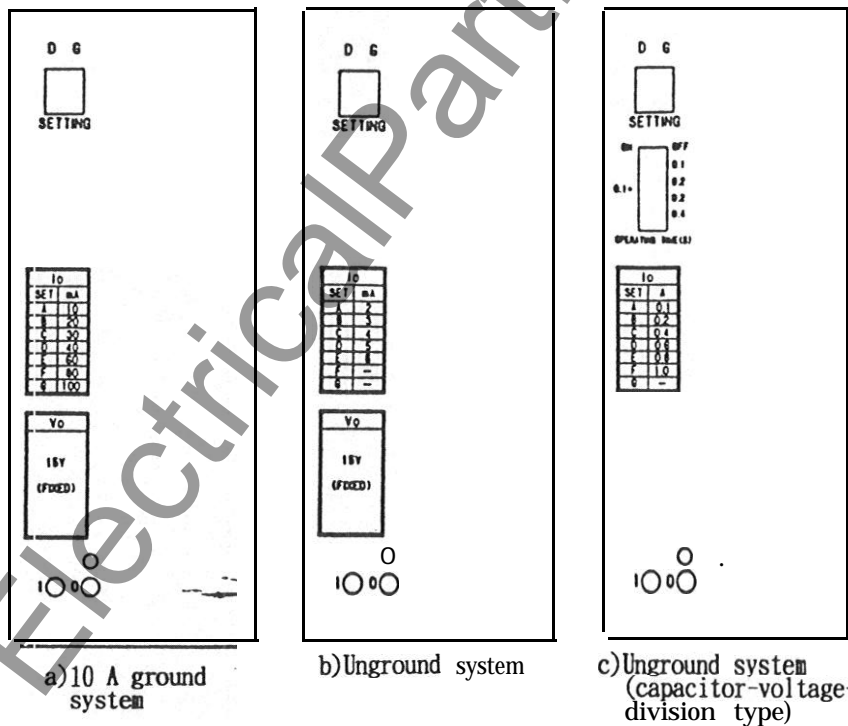

Figure 14 Front External View of Directional Ground Modules

6. MAINTENANCE AND INSPECTION

This chapter summarizes the method of maintenance and inspection for assuring normal operation of the S2E21 for a long period of service. Consult this chapter when you make periodic inspection and troubleshooting.

6.1 Periodic Inspection

Inspection of the S2E21 should be done according to the following criteria.

6.1.1 Inspection Interval

- (a) About 1 year when the environments is relatively good (in normal electric rooms).
- (b) About 6 months when the environment is very bad.

6.1.2 Inspection Item

(a) Dust and dirt

When the surrounding portions of the conductors are dirty, wipe them clean with dry cloth. Never use organic solvents such as gasoline or benzine.

(b) Loose screws

Retighten loose screws with screwdriver.

(c) Check of settings

Check the settings against the setting table.

(d) Characteristic and operation check

When required, a check should be made of the protection characteristic.

(e) Others

Check for abnormal indication, damages or other abnormalities.

6.1.3 Replacing Parts

The following parts should be replaced periodically.

(1) LCD Indicator

Replacement interval: about 5000 hours of lighting

Parts to be replaced:

Part code	Part name	Remark
4D9E0054G003	Liquid crystal display	TOSHIBA TLX-341AX with special connector

Method of replacement:

- 1) Turn off the control supply for S2E21.
- 2) Open the display section.
- 3) Disconnect the LCD wire at the connector.
- 4) Remove the four screws that fix the LCD and then remove the LCD.
- 5) Mount a new LCD and fasten the set screws.
- 6) Connect the LCD wire to the connector.

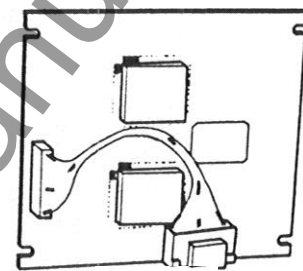
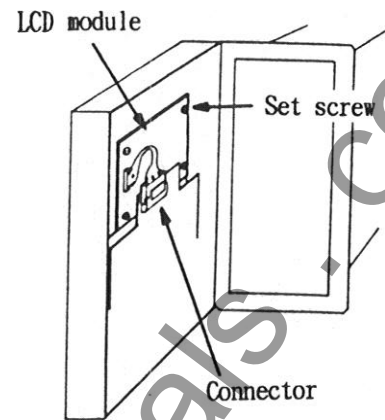

(2) Battery

Replacement interval: Approximately every 2 years.

Parts to be replaced:

Part code	Part name	Rating
CR 2025 equivalent	Lithium coin battery	3 V

Method of replacement:

- 1) Turn off the control supply for the S2E21.
- 2) Open the display section.
- 3) Remove the battery from the battery holder.

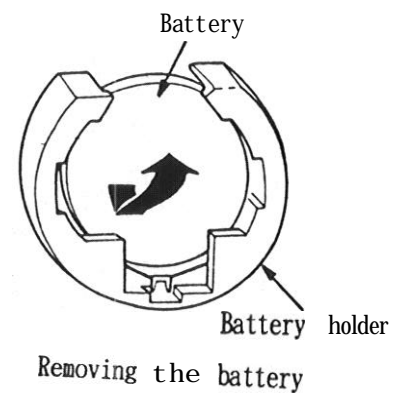

- 4) Install the new battery.
- 5) Reset the calendar and clock.

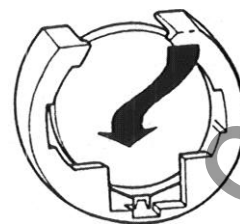

Installing the battery

6.2 Troubleshooting

Phenomenon	Check point	Possible cause	What to do
Nothing appears on the LCD display	Power LED is off.	Control power is off or incorrect.	If the control power connection is wrong, correct it. (See Section 4.2.)
	Error LED is lit.	There is an internal problem with the relay.	Turn control power off and turn it on again. If LED remains lit, consult nearest TOSHIBA.
	Operation of the keypad has not been done for about 4 min.	Normal.	Press the [EXE] key. (See Section 5.3.5.)
	Open the door panel and check if there is a loose connection between the LCD display and the door panel or between the door panel and the relay body.	Bad connection.	Connect firmly. (See Section 6.1.3.)
	Displayed characters are faint.	Brightness reduced.	Adjust brightness. (See Section 5.3.4.)
	LCD display used for more than 5000 hours.	LCD life expired.	Replace LCD display. (See Section 6.1.3.)

Phenomenon	Check point	Possible cause	What to do
LCD indicates P98.	Error LED is lit. Error LED is not lit.	Setting value is incorrect. Normal.	Press the [EXE] key and enter all setting values again. (NOTE) Display other pages. (See Section 5.3.1.)
In LCD indicator or P0 Second cannot be set.		Normal.	The second setting is not provided.
Or P2 The display does not change while the metered value changes. θ R remains 0. UB remains 0.	At lower part of LCD, “ >>>SELECT P2 <<<” is indicated. T S C (25-2) on P25 is 0 (OFF). U B (23-2) on P23 is 0 (OFF).	The page is being turned. Normal. Normal.	Press the [EXE] key to change to the display mode. Change value from zero Change value from zero
On P3 999 is displayed.	Is item measured in the temperature range between 20°C and 200°C?	Cable connection is bad.	Firmly connect cable and connector.
On P 4 I s t (4-3) and T s t (4-4) remain at 0.	Motor has not been started more than five times, and learned function is selected.	Normal.	The measured value is displayed after the motor is started five times.

NOTE: Pressing the [EXE] key returns the setting to those values set at time of delivery.

Phenomenon	Check point	Possible cause	What to do
Dn P28 - PRE-ALM setting of UC does not go below 100%.	—	Normal.	PRE-ALM setting of UC has a range between 100% and 300%.
Dn P30 - Cursor will not move to ALM of I NST and UB - Trip output fails to be produced. - Alarm output is not produced.	— Protection function is locked. Output is not selected at RY O/P SEL (P30). In O/P RELAY CONFIG (P29), the logic is inverted. External connection is incorrect or loose. Protection function is locked. Output is not selected at RY O/P SEL (P30). In O/P RELAY CONFIG (P29), the logic is inverted. External connection is incorrect or loose.	Normal. Normal. Normal. Bad connection. Normal. Normal. Normal. Bad connection.	ALM setting is not provided for I NST and UB. Activate the protective function. Select(1) to activate. Match the logic. Make proper connection. Activate the protective function. Select(1) to activate. Match the logic. Make proper connection.

Phenomenon	Check point	Possible cause	What to do
Cannot be reset.	Trip state continues (OC, UC, INST. UB, OCG) After OL, the reset level (28-4) of θS and θR (2-3) is still exceeded.	Normal. Normal.	Stop the motor and correct the problem. Wait for the motor to cool. CAUTION: Since the motor is overheated, take utmost caution
Transducer output does not change.	On P31, A T D O/P is not set. P40 is displayed.	Normal. Normal.	Enter the necessary setting. Change to page other than P40.
REP is activated when the motor is	On P25, TSC (25-2) is set lower than T s t (25-5).	incorrect setting.	Enter the correct setting.

6.3 Bench Test

Item		Test method	Decision	Test circuit (single phase)
IL	Operating point	Gradually increase current and record the current value when the RUN LED begins blinking at 0.3 s intervals.	$I_N \sqrt{\frac{\theta_{SM}}{\theta_{SN}}} \pm 10\%$ $I_N : \text{Rated current}$ $\theta_{SM} : \text{Stator allowable temperature rise}$ $\theta_{SN} : \text{Stator rated temperature rise}$	Figure 15
	Operating time	<p>1) On P2, check that θS is 0. When it is not 0, either wait, or on P35, clear θS.</p> <p>2) Apply 6 times the rated current (I_N) abruptly and measure the time it takes for the relay to trip.</p>	$-60 \times TR \times \left(1 - \frac{\theta_{SM}}{\theta_{SN}} \cdot \left(\frac{I_N}{I}\right)^2\right) \pm 10\%$ $I = 6 \times I_N$ <p>TR: Heating time constant</p>	Figure 15
IC	Operating point	Gradually increase the current and measure the current value when the relay trips.	Setting value $\pm 5\%$	Figure 15
	Operating time	<p>1) Apply the rated current (I_N).</p> <p>2) Apply current 1.5 times the setting value (I_{OC}) and measure the time it takes for the relay to trip.</p>	Setting value $\pm 10\%$	Figure 15

Item	Test method	Decision	Test circuit (single phase)	
UC	Operating point	Apply rated current and gradually lower the current. Measure the current value at which the relay trips.	Setting value $\pm 10\%$	Figure 15
	Operating time	1) Apply the rated current (I_N). 2) Quickly reduce the current to 20% of the rated current and measure the time it takes for the relay to trip.	Setting value $\pm 10\%$	Figure 15
INST	Operating point	Gradually reduce the current and measure the current value at which the relay trips.	Setting value $\pm 15\%$	Figure 15
	Operating time	Quickly apply current two times the setting value ($I_{>>}$) and measure the time it takes for the relay to trip.	50 ms or less	Figure 15

Item	Test method	Decision	Test circuit (single phase)
JB	Operating point	Slowly reduce the current and measure the current value at which the relay trips. 75% ±10% of the rated current (I _N)	Figure 16
	Operating time	1) Apply the rated current (I _N). 2) Quickly change current in one phase to 0 and measure the time it takes for the relay to trip. Less than 4 s.	Figure 16
	Unbalance factor	1) Apply the rated current (I _N). 2) Change current in one phase and measure the current at which the relay trips.	$\frac{I_1 - I_2 - I_{AVE}}{I_N} \times 100\%$ <p>The calculated value must be within ±5% of the setting value.</p> <p>Example: When the setting value is 30%, the calculated value must be in the range of 25 to 35%.</p> <p>I₁: Measured current value.</p> $I_{AVE} = \frac{I_N + I_N + I_t}{3}$

Item		Test method	Decision	Test circuit (single phase)
θ R	Operating time	<p>1) On P2, check that θ R is 0. When not 0, clear θ R.</p> <p>2) Quickly increase the applied current from 0 to 3 times the rated current (I_N) and measure the time it takes for the relay to trip.</p>	$\left(\frac{I_{st}}{3}\right)^2 \times TSC \text{ (sec)} \pm 10\%$ <p>I_{st}: Starting current TSC: Allowable starting-time</p>	Figure 15
REP	Operating point	<p>1) On P2, check that θ R is 0. When not zero, either wait or clear θ R on P35.</p> <p>2) Apply the starting current (I_{st}) and measure the % value of θ R on P2 when the lock output is produced.</p>	$1 - \frac{T_{st}}{TSC} \pm 10\%$ <p>T_{st}: Starting time</p>	Figure 15

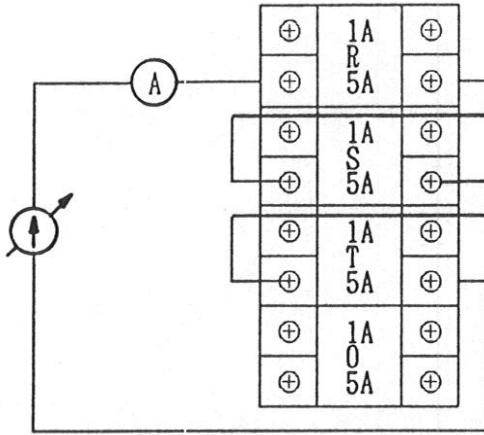

Figure 15 Test Circuit (1)

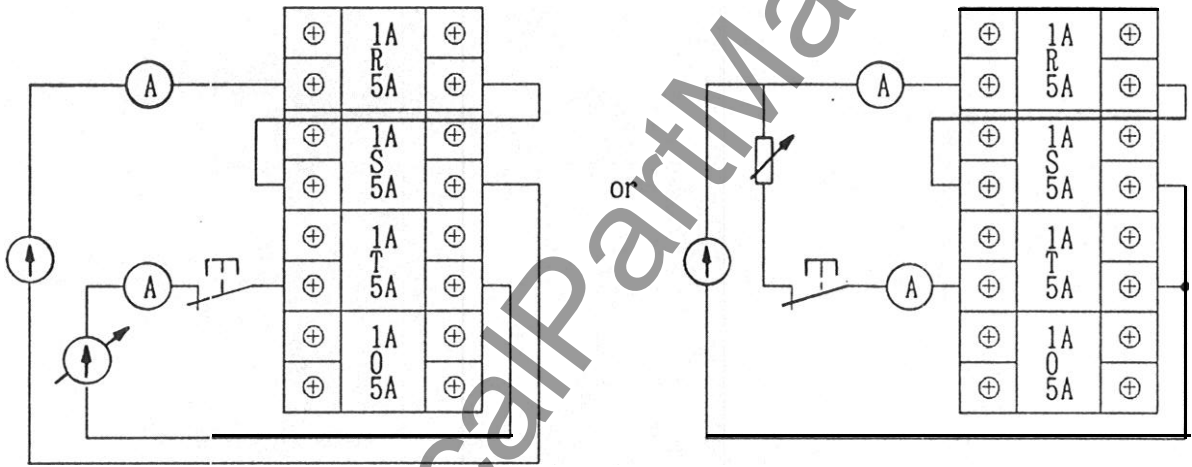

Figure 16 Test Circuit (2)

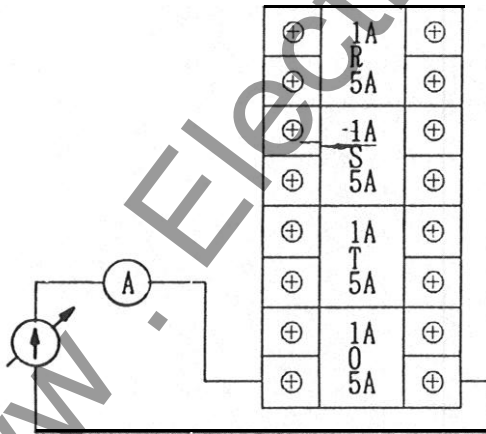

Figure 17 Test Circuit (3)

7. PROTECTIVE DETECTION SCHEME

This chapter describes how the protective unit of the S2E21 detects failures.

7.1 Overload Unit

This is a function to thermally protect the motor insulations. The component to be protected is mainly the stator. Changes in stator temperature when the motor is in operation and at rest are represented by the following formula.

[During operation]

$$\theta_1(t) = \theta_{\infty}(I_t) \cdot (1 - e^{-t/TR}) \quad \dots \dots \dots * \dots * \dots \quad (1)$$

where

$\theta_1(t)$: Temperature rise in time t

$\theta_{\infty}(I_t)$: Final temperature rise that occurs when the stator current I_t flows continuously and which is determined by the magnitude of I_t .

TR: Motor's heating time constant

[At rest]

$$\theta_2(t) = \theta(0) \cdot e^{-t/TD} \quad \dots \dots \dots (2)$$

where

$\theta_2(t)$: Temperature rise in time t

$\theta(0)$: Temperature rise when the motor is at rest ($t = 0$).

TD: Motor's cooling time constant

The equations (1) and (2) are represented in the following diagrams.

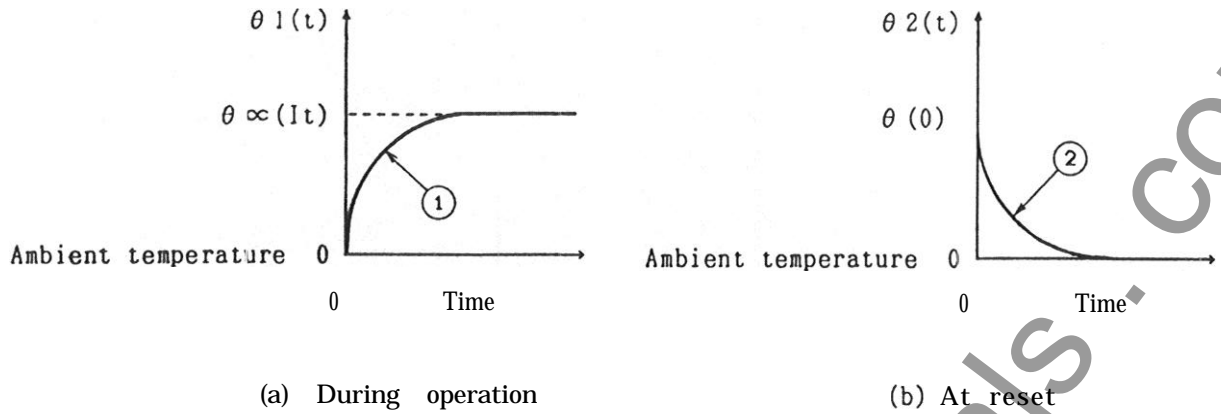

Figure 15 Stator temperature rise

In other words, the **stator** temperature rises exponentially during motor operation to a certain temperature that is determined by the current magnitude. When the motor is stopped, the **stator** temperature falls down to the ambient temperature.

This relay determines whether the motor is running or at rest by checking the presence of the **stator** current. Then it performs the calculation of equation (1) or (2) to simulate the heated condition of the motor.

The **stator** current is sampled at predetermined intervals and the sampled currents are successively fed to the calculation process in order to perform the thermal simulation in response to the changes in the motor operating condition.

Figure 16 shows a timechart that represents changes in the simulated temperature rise in response to changes in the motor operating condition (current changes).

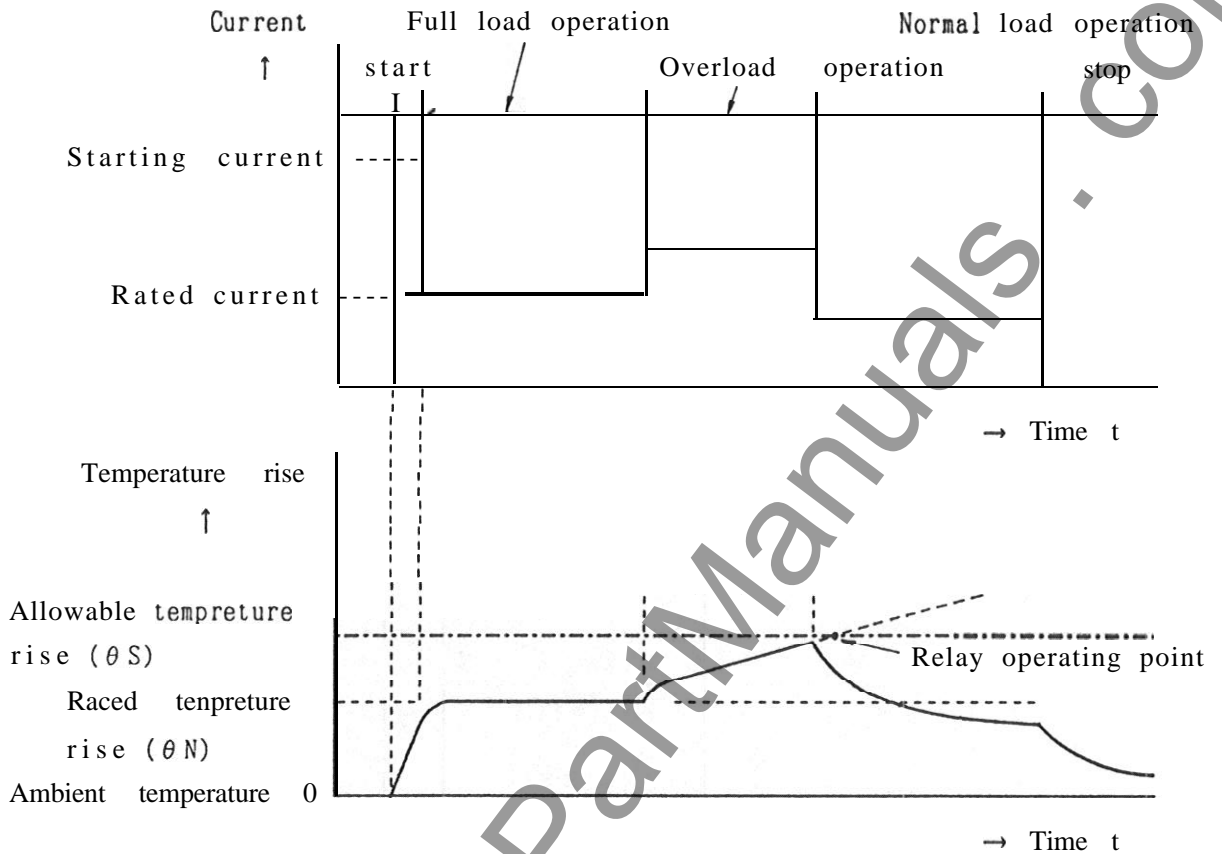

Figure 16 Simulated Temperature Rise Timechart

In Figure 16, the allowable temperature rise (θ_{SM}) is a value dependent on the insulation design of the motor and is defined in Table 5 by JIS-4004 and NEMA MG1-1.65.

Table 5 Insulation Class and Allowable Temperature Rise

Insulation class	Allowable temperature rise θ_S (°C)
Class A	60
Class E	75
Class B	80
Class F	100 (105)*
Class H	125

*(): NEMA

The rated temperature rise (θ_{SN}) represents a temperature rise for the motor's rated current (full load current). This value is usually submitted by a motor manufacturer as test data.

This relay requires setting of the motor's heating time constant and the cooling time constant. These values are also supplied as the motor data. When they are not shown, request them from the motor manufacturer.

As a reference, the standard values of Toshiba motors are shown in Table 6.

Table 6 Heating Time Constant of Motor
(Toshiba Standard Values)

Frame	Motor kind		Time constant (minute)		
	Totally enclosed outer fan	Other than totally enclosed outer fan		Heating TR	Cooling I ₁
		2 poles	4 poles or more		
—	355	—	30	3xTR	
50 or less	400	355	45		
500, 560, 630	450-630	400-630	60		
710 or more	710 or more	710 or more	90		
710	—	—	120		

7.2 Locked Rotor Unit

The Locked Rotor Unit (L.R) has a main function of protecting the rotor of a motor as opposed to the Overload (OL) which protects the stator of the motor.

In providing protection, the S2E21 simulates temperature rises of the stator and rotor in a motor independently because each has different thermal characteristics.

For the load currents that are below about 2.5 times the rated current, the heat of the motor is produced mainly by the stator, and for higher load currents, the rotor produces most of the heat,

For this reason, the S2E21 performs the temperature rise simulation for the rotor as follows:

- (1) When the load current is less than 2.5 times the rated current ($0 < I(t) < 2.5 \times I_N$):

The temperature rise θ_R of the rotor is made to converge into the temperature rise θ_S of the stator by the heating time constant (TR)

- (i) When $\theta_R(t) < \theta_S$:

$$\theta_R(t) = \theta_S (1 - e^{-t/TR}) \dots \dots \dots (3)$$

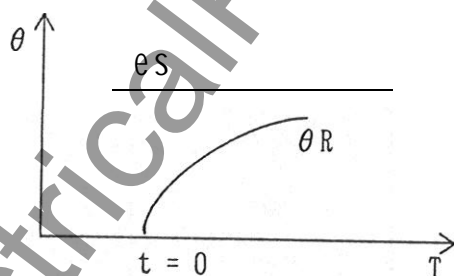

- (ii) When $\theta_R(t) > \theta_S$:

$$\theta_R(t) = (\theta_R(0) - \theta_S) e^{-t/TR} + \theta_S \dots \dots \dots (4)$$

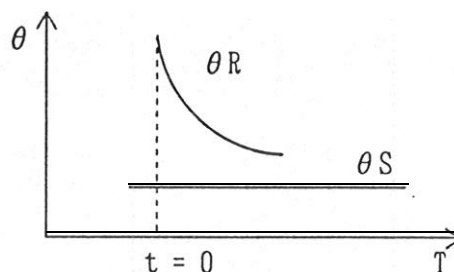

Where θ_R : temperature rise of the rotor at time t (°C)

θ_S : temperature rise of the stator at time t (C)

TR: heating time constant of the motor (minute) (set value)

- (2) When the load current is higher than 2.5 times the rated current ($2.5 \times I_N < I(t)$):

From the heating characteristic during locking that is determined by the motor starting current (Ist) and the allowable locking time, the temperature rise of the rotor is simulated.

When at time 0 the rotor is locked, then

$$\theta_R(t) = \theta_R(0) + \left(\frac{I(t)}{I_{st}}\right) \cdot \frac{1}{TSC} \cdot \theta_{RM} \cdot t \dots\dots\dots(5)$$

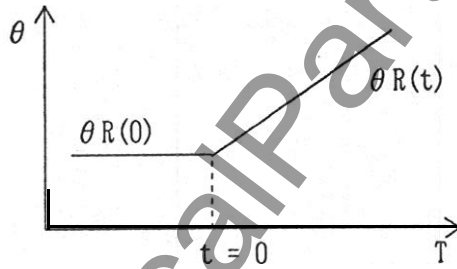

Where $\theta_R(t)$: temperature rise of the rotor at time t (°C)

$\theta_R(0)$: temperature rise of the rotor before the rotor is locked (C)

$I(t)$: load current at time t (A)

Ist: starting current (A) (setting value)

TSC: allowable locking time in the cold state (sec) (setting value)

θ_{RM} : allowable temperature rise of the rotor (CC) (fixed at 200°C)

When $\theta_R(t) = \theta_{RM}$, the trip operation is carried out.,

The operation characteristic (operating time) in the locked state varies depending on the heated condition of the motor and the conducting current.

When the starting current is flowing in the locked state, the operating time will be as follows:

(i) In cold condition (motor is cool):

In equation (5),
since $\theta_R(0) = 0$.

the operating time is TSC (sec).

TSC: allowable locking time in cold state (sec) (setting value)

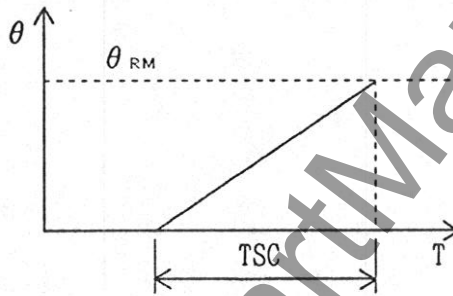

(ii) In hot condition (motor is running at the rated load):

In equation (5),

since $\theta_R(0) = \theta_{SN}$,

the operating time will be $T_{SH} = \frac{\theta_{RM} - \theta_{SN}}{\theta_{RM}} \cdot TSC$ (sec).

Where θ_{SN} : rated temperature rise value (sec) (setting value)

T_{SH} : allowable locking time in hot condition (sec)

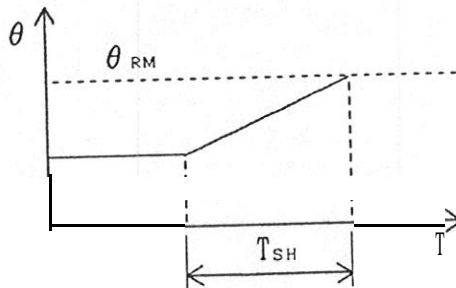

(iii) In operating condition:

In reality, $\theta_{R(0)}$ falls between 0 and θ_{SN} . The operating time in this case is given by:

$$T_{OP} = \frac{\theta_{RM} - \theta_{R(0)}}{\phi'_{RM}} \cdot TSC \text{ (sec).}$$

Where T_{OP} : operating time

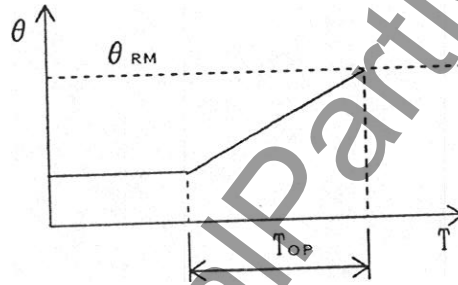

7.3 Repetitive Starting

When the motor is started, the repetitive starting protection checks the starting current and the starting time to see if the temperature rise exceeds the rotor's allowable temperature rise. If the allowable temperature rise of the rotor is exceeded, this protective function issues a lock signal to prevent the motor from starting.

The rotor heating caused by a single starting is expressed by the following equation:

$$\frac{T_{st}}{TSC} \cdot \left(\frac{I(t)}{I_{st}}\right)^2 \cdot \theta_{RM} \dots \dots \dots (6a)$$

However, if at starting $I(t) = I_{st}$, then the following holds:

$$\frac{T_{st}}{TSC} \cdot \theta_{RM} \dots \dots \dots (6b)$$

Where T_{st} : motor starting time (sec) (setting value)

TSC : allowable rotor locking time (sec) (setting value)

θ_{RM} : allowable rotor temperature rise (°C) (fixed at 200°C)

I_{st} : starting current (A) (setting value)

Hence, when there is no margin defined in (6b) between the rotor's temperature rise $\theta_R(t)$ and the allowable rotor temperature rise θ_{RM} , a lock output is issued.

$$\theta_{RM} - \theta_R(t) \leq \frac{T_{st}}{TSC} \cdot \theta_{RM}$$

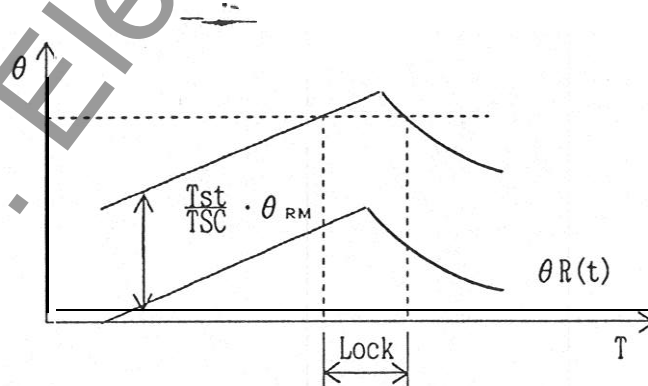

7.4 Detection of Starting Current and Starting Time

The S2E21 checks a motor current to detect whether the motor is stopped, starting, running or overloaded. The detection conditions are as follows:

- (1) Stopped: When the motor current is less than 5% of the motor's rated current (I_N).
- (2) Starting: From the time when the motor current exceeds 1.5 times the motor rated current (I_N) as it leaves the stopped condition until the motor current falls below 1.5 times the motor rated current.
- (3) Running: Not during the starting period, when the motor current is higher than 5% of the motor rated current, but lower than a current that will trigger the overload (OL) function.
- (4) Overloaded: Not during the starting period, when the motor current exceeds the operating value for the overload (OL) function.

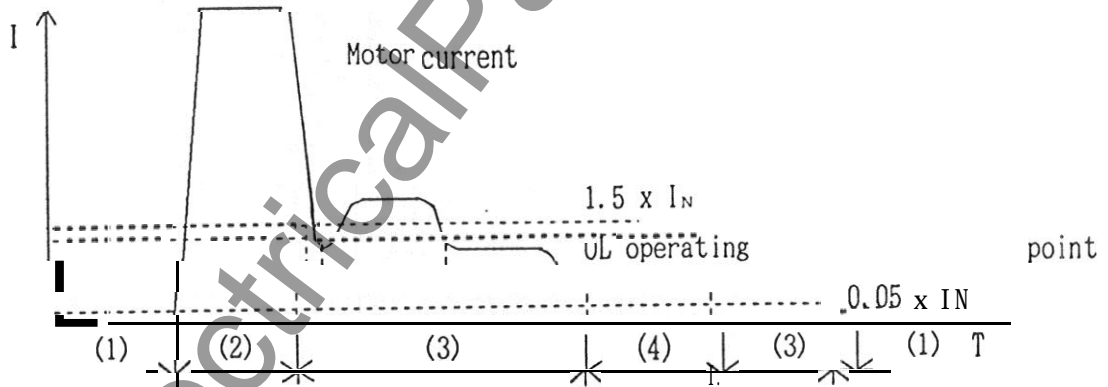

(1) Starting current

The starting current is a current value that exists 100 ms after the relay has detected that the motor is starting. The starting current is obtained by taking an average of five starting currents.

(2) Starting time

The time 2 shown in the diagram above is taken as a starting time. The starting time is obtained by taking an average of five starting times.

7.5 Detection of the Heating Time Constant and Cooling Time Constant

CAUTION:

Detecting the heating time constant and the cooling time constant requires three RTDs in the winding and one RTD for measuring the ambient temperature to determine the motor temperature rise. To enhance the detection accuracy, care should be taken of the following points:

- (1) The RTD for measuring the ambient temperature provides a reference temperature for determining the motor temperature rise, so make sure that you measure the ambient temperature precisely.

The measuring error of the ambient temperature will have great effect on the detection accuracy of the heating time constant and the cooling time constant.

- (a) Do not allow the RTD to be affected by heat from the motor.
 - (b) Keep the RTD free from direct sun rays or radiant heat.
 - (c) Keep the RTD free from influences of cool air and drafts.
 - (d) Keep the RTD free from moisture or high humidity.
- (2) To maintain a required level of accuracy, the heating time constant and the cooling time constant are detected under the conditions described later.

The motor must be able to be operated in ways that meet these requirements.

The relationship between the motor temperature rise and the heating time constant is given in equation (1) and the relationship between the motor temperature and the cooling time constant is given in equation (2).

$\theta 1(t)$ and $\theta 2(t)$ represent the motor temperature rises, which can be determined by measuring the motor winding temperature and the ambient temperature using the RTDs. $\theta (It)$ is determined by the motor current.

The S2E21 receives signals from the three RTDs in the winding at its inputs RTD1, RTD2, and RTD3 and also the ambient temperature at RTD8 to determine the heating time constant and the cooling time constant from the motor temperature rises. The accuracy of calculating these time constants is about $\pm 10\%$.

From equation (1), the heating time constant is expressed as

$$TR = \frac{t_2 - t_1}{C_n \frac{\theta (It) - \theta 1(t_1)}{\theta (It) - \theta (t_2)}} \dots\dots\dots (1')$$

From equation (2), the cooling time constant is given by

$$TD = \frac{t_2 - t_1}{C_n \frac{\theta 2(t_1)}{\theta 2(t_2)}} \dots\dots\dots (2')$$

At each start and stop of the motor, the heating time constant and the cooling time constant are detected over a length of time equivalent to these time constants. Five measurements are taken and averaged to determine the heating time constant and the cooling time constant.

[Requirements for detecting the heating time constant]

- The motor is sufficiently cool.
- The motor current is large enough (not too lightly loaded).
- The motor is not overloaded.

[Requirements for detecting the cooling time constant]

- The motor is sufficiently heated.

7.6 Settings Based on Fundamental Information

When setting the protective characteristics of the S2E21 according to fundamental information alone that you can obtain from the rating nameplate of the motor, the following steps should be taken.

In this case, however, use overly conservative characteristics to ensure the motor safety. Note that the temperature rises (θS , θR) are different from the actual motor temperature rises.

To perform accurate temperature rise simulation and protection, it is necessary to set the motor constants.

Fundamental information:

I_{MFLC} : motor rated current (A)

CT: CT secondary current (A)

θSM : allowable motor temperature rise

TSC: allowable motor locking time during cold condition

Tst: starting time (sec)

Ist: starting current (A)

20-Z: CT ratio (given)

20-3: ZCT ratio 50 A

This does not affect the protection characteristics.

20-4: rated current setting (IN).

This is calculated by the following equation:

$$I_N = I_{MFLC} (A) / CT (A)$$

21-2: Setting of the heating time constant (TR)

$$TR (\text{min}) > 3 \times Tst$$

When Tst is less than 3, setting should be

$$TR = 10 (\text{min})$$

21-4: Setting of the cooling time constant (TD)

It should be set to 0 (TD = 3 x TR)

21-6: Setting of the allowable motor locking time (θ_{SM})

Setting depends on the insulation class of the winding. See Table 5 (Table A1).

21-T: Setting of the rated temperature rise (θ_{SN})

$$\theta_{SN} = \theta_{SM} \div 1.2 \text{ (}^\circ\text{C)}$$

Under this condition, the operating point of OL is given by

$$1.1 \times I_{MFLC} \left(\sqrt{\frac{\theta_{SM}}{\theta_{SN}}} = 1.1 \right)$$

22-2: Setting of the INST current (I>>)

This function should be locked when a combination starter is used as the motor starter.

When switchgear incorporating a circuit breaker is used as the starter, the following characteristics should be coordinated during the setting procedure:

- Motor starting current
- Motor inrush current
- Switchgear's overcurrent relay characteristics

22-3: Setting of INST time (T>>)

This is fixed at 0.05 s.

22-4: Setting of OC current (I_{oc})

OC is not for the motor protection but for the protection of equipment connected to the motor. OC is locked when the equipment protection is not needed.

When OC is required, set to 1.5 (times).

22-5: Setting of OC time (T_{oc})

Set OC time to 0.3 s.

23-2: Setting of unbalance factor (UB)

Set UB to 5%.

23-3: Setting of UC current (I_{uc})

UC is not for the motor protection, but for preventing an underload or less of load condition.

When not necessary, it is locked.

When needed, set to 80 (%).

It is recommended however that you measure

the no-load current I_{NLC} and set the UC current to $1.2 \times I_{NLC}$.

- 23-4: Setting of UC time (T_{UC})
Set to 1 s.
- 24-2: Setting of OCG current (I_{OCG})
To prevent undesired operation, Set to 10 (%).
- 24-3: Setting of OCG time (T_{OCG})
Set to 0.1 s.
- 25-2: Setting of allowable locking time in cold condition (T_{SC})
Given value (Consult motor manufacturer)
- 25-3: Starting current (I_{st})
See motor data.
Or after one start, read screen P4. (See page 50, 4-2.)
- 25-4: Starting time (T_{st})
Varies per application. (motor, load, type of starter)
- calculate based on motor torque and load .
 - Or after one start, read screen P4. (See page 50, 4-4.)

7.7 Settings For Reduce Voltage Starting

For reduce voltage starting, the actual starting current is different from the nameplate of the motor.

Perform the following steps for setting of TSC. Ist and Tst for locked-rotor protection. In this case, Auto learning function of Tst and Ist should not be turned on.

25-2: Setting of allowable locked-rotor time in cold condition (TSC)
Given value (Consult motor manufacturer)

25-3: Starting current (Ist)
See motor data (at full voltage.)

25-4: Starting time (Tst)
- Convert the actual starting time to setting value based Ist.

$$Tst = \left(\frac{Ist.act}{Ist} \right)^2 \cdot Tst.act$$

Where Tst : starting time (setting value)

Tst.act : actual starting time at reduced voltage.

Ist : starting current (motor data at full voltage)

Ist.act : actual starting current at reduced voltage.

- Actual starting time should be calculate based on motor torque and load. or after one start read screen P4. (See manual page 50, 4-4.)
- Actual starting current should be calculated, or after one start read screen P4. (See manual page 50, 4-4.)

Following the above procedure protects the motor under a full voltage locked-rotor condition and allows a longer starting time for reduced voltage (reduced inrush current) starting.

Appendix A

S2E21 RELAY SETTING					
Relay Screen	Item	Description	Setting range	Setting Step	Setting
P20	CT Ratio	CT Primary Rating	5-2000A	1A	
P20	ZCT Ratio	ZCT Primary Rating	50-100A	1A	
P20	IN	MFLA/CT Primary Rating	40-100%	1%	
P21	TR	Moter Heating Time Constant	10-165 Min.	1 Minute	
P21	θ_{SM}	Stator Allowable Temperature Rise	60-125 Deg. C	1 Deg. C	
P21	θ_{SN}	Stator Norm. (100% Load) Temperature Rise	10-125 Deg. C	1 Deg. C	
P22	I>>	Instantaneous (Short Circu)vercurrent	5-17×IN	1.0×IN	
P22	T>>	Instantaneous OC Time Delay	Fixed	N/A	0.05 Sec.
P22	IOC	Overcurrent	1.5-10.0×IN	0.1×IN	
P22	TOC	Overcurrent Time Delay	0.3-1.0 sec.	0.1 Sec.	
P23	UB	Unbalance (Current)	5-30%	1%	
P23	IUC	Undercurrent	30-80%	1%	
P23	TUC	Undercurrent Time Delay	1-5 Sec.	1 Sec.	
P24	OCG	Ground Overcurrent (Trip Value/ZCT Pri. ×100%)	5-40%	1%	
P24	TOCG	Ground Overcurrent Time Delay	0.1-1.5 Sec.	0.1 Sec.	
P25	TSC	Allowable Starting Time	1-130 Sec.	1 Sec.	
P25	Ist	Starting Current/MFLA	1.5-15.0×IN	0.1×IN	
P25	Tst	starting Time	1-60 Sec.	1 Sec.	
P26	ADD.	Communication Address (Relay #)	1 to 31	1	
P26	Remote set	Remote Setting Fro. Computer	0=No, 1=Yes	—	
P28	OL Alarm/Reset	Selection of Alarm/Reset Values	1-100 %	1 %	
P28	oc Alar.				
P28	UC Alarm	Selection of Alarm Value	100-300 %	1 %	
P28	INST Alarm/Reset	Not Applicable	—	—	—
P28	UB Alarm/Reset	Not Applicable	—	—	—
P28	OCG Alarm	Selection of Alarm Value	1-100 %	1 %	
P29	Trip Relay Config.	Selection of Fall-safe or Non-Fall-safe Operation	0=N. F. S., 1=F. S.	—	
P29	Alarm Relay Config.	Selection of Fall-safe or Non-Fall-safe Operation	0=N. F. S., 1=F. S.	—	
P29	Look Relay Config.	Selection of Fall-safe or Non-Fall-safe Operation	0=N. F. S., 1=F. S.	—	
P30	OL Relay Operation	Selection of Alarm/Trip Relay Operation	0=Nop., 1=Oper.	—	
P30	OC Relay Operation	Selection of Alarm/Trip Relay Operation	0=Nop., 1=Oper.	—	
P30	UC Relay Operation	Selection of Alarm/Trip Relay Operation	0=Nop., 1=Oper.	—	
P30	INST Relay Operation	Selection of Trip Relay Operation	0=Nop., 1=Oper.	—	
P30	UB Relay Operation	Selection of Trip Relay Operation	0=Nop., 1=Oper.	—	
P30	LR Relay Operation	Selection of Trip Relay Operation	0=Nop., 1=Oper.	—	
P30	OCG Relay Operation	Selection of Alarm/Trip Relay Operation	0=Nop., 1=Oper.	—	
P30	RTD Relay Operation	Selection of Alarm/Trip Relay Operation	0=Nop., 1=Oper.	—	
P30	Spare 1 Relay Oper.	Selection of Alarm/Trip Relay Operation	0=Nop., 1=Oper.	—	
P30	Spare 2 Relay Oper.	Selection of Alarm/Trip Relay Operation	0=Nop., 1=Oper.	—	
P31	ATD O/P	4-20mA Analog Output Signal Selection	4-20 mA	1 mA	—
P32	RTD Type	Sets RTD Type (Pt100, Pt100(JIS), Ni100, Ni120)	—		
P33	RTD Alm/Trp/Reset	Selection of Alarm/Trip/Reset Values	0-200 Deg. C	1 Deg. C	
P34	Ist Auto Learning	Selection of Auto Learning	0=Off, 1=On	—	
P34	Tst Auto Learning	Selection of Auto Learning	0=Off, 1=On	—	
P34	TR Auto Learning	Selection of Auto Learning	0=Off, 1=On	—	
P34	TD Auto Learning	Selection of Auto Learning	0=Off, 1=On	—	

Notes: N/A-Not Applicable