



# INSTALLATION • OPERATION • MAINTENANCE I N S T R U C T I O N S

## TYPE SAR, SAR-1, and SAR-2 AUXILIARY RELAY

### APPLICATION

The type SAR, SAR-1, and SAR-2 are ultra high speed auxiliary relays. The SAR is a tripping auxiliary relay which accepts a low voltage input or a high voltage input from a fault detecting relay. The SAR-1 is also a tripping auxiliary but accepts only a high voltage input. Both the SAR and SAR-1 relays are available with either single or double Thyristor (Silicon controlled rectifier) outputs. Once the Thyristors are fired they must be reset by a 52a contact or equivalent. For the application of the SAR and SAR-1 refer to figures 5 and 6. The SAR-2 accepts either a low or high voltage input and has a diode bridge output circuit which does not latch-on. The relay is applied in breaker failure schemes for starting the breaker failure timer because of its automatic reset feature. Figures 7 and 8 show this application of the SAR-2.

### CONSTRUCTION

The auxiliary units are packages in a perforated cage with a molded cover and a molded base (with terminals) for projection mounting. Figure 1. Types SAR and SAR-1 are available with either a single or a dual output. The SAR shown in Figure 2 consists of two Thyristors (each with its own gating circuit, latch-on, and protective components), a three-winding pulse transformer, a 4-layer diode, a pulse capacitor, a two-transistor amplifier, a zener diode voltage regulator, and a current limiting power resistor.

The SAR-1 shown in Figure 3 is similar to the SAR except it does not have an amplifier or a voltage regulator.

The SAR-2 shown in Figure 4 is similar to the SAR except the Thyristors are each replaced by a full-wave bridge rectifier and a filter circuit.

The circuits are contained on printed circuit boards which are plugged into edge connectors. The

boards can be removed for inspection and tests and then reinserted into the connector. Access to the boards is gained by removing the screw in the center of the top. Then the top and perforated cage can be removed.

### OPERATION

#### Amplifier Circuit

In the SAR and SAR-2 current flow into the pulse circuit is controlled by a PNP type transistor Q5. A standby potential of 48, 125, or 250 volts d-c or more is required at terminal 1 with battery negative connected to terminal 4. Voltage across the amplifier circuit is regulated at 33 volts d-c by the zener diode DZ3 and voltage dropping resistor R1.

The amplifier is turned on by a positive potential of 5V d.c. to 35 V.D.C. applied to terminal 3 or by 35V d.c. to 125V d.c. applied to terminal 2 or by both with negative polarity connected to terminal 4. This causes current to flow into the base of the first stage transistor Q4 which is thereby driven into the conducting state. Base current for Q5 then flows through R6 and Q4 causing Q5 to conduct current into the pulse circuit. When the positive signal is removed from terminal 2 and 3, Q4 reverts to a nonconducting state to block base current in Q5. Q5 then prevents the flow of current into the pulse circuit.

#### Pulse Circuit

A capacitor C1 and four-layer diode Q1 produce the gating pulses delivered to the transformer. When a voltage is allowed to develop across C1, it reaches the breakover level of the four-layer diode. At this time the diode Q1 quickly switches from a blocking state to a low resistance conducting state and thereby allows full capacitor voltage to be applied to the transformer primary. When C1 is discharged, Q1 switches back to the blocking state until its breakover voltage is reached again. This

**SUPERSEDES I.L. 41-843A**

\*Denotes change from superseded issue.

**EFFECTIVE JULY 1969**

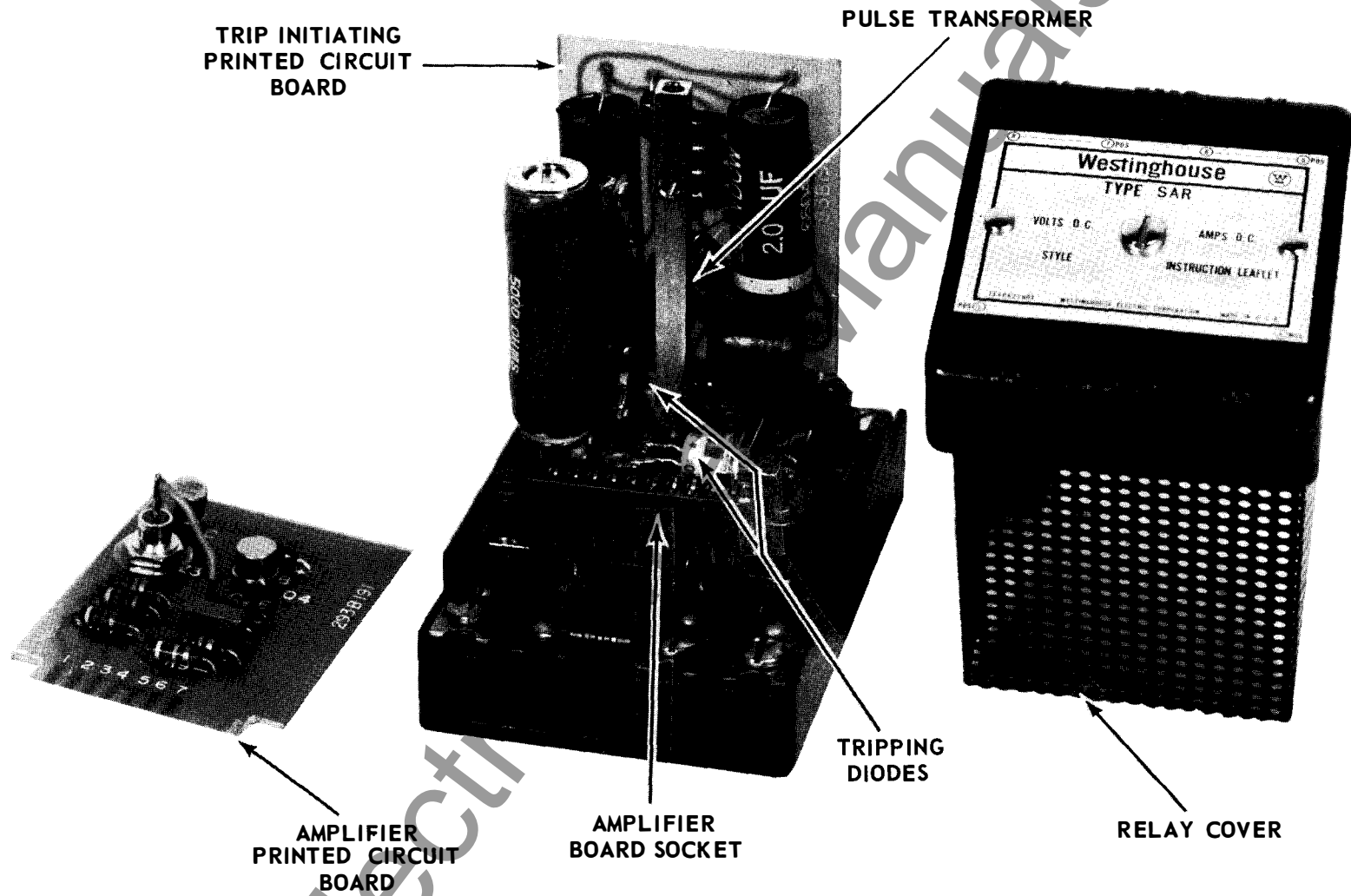

Fig. 1. Type SAR Relay

process continues as long as voltage is applied to the pulse circuit. Pulses are applied to the gate circuit at a rate of four pulses per millisecond. In the SAR-1, current flow into the pulse circuit capacitor is initiated by applying a positive potential to terminal 1.

**Pulse Transformer**

Gating for the Thyristors Q2 and Q3 is provided through the three winding pulse transformer T. The transformer provides isolation for the Thyristor circuit from the initiating circuit.

**Thyristor**

The Thyristor is a three-terminal semiconductor device. In the reverse, or nonconducting direction, the device exhibits the very low leakage characteristics of a silicon rectifier. In the forward, or conducting direction, conduction can be initiated by the application of a control pulse to the control terminal or "gate". If a gate signal is not applied, the device will not conduct at below rated forward

blocking voltage. With the application of a gate signal, however, the device switches rapidly to a conducting state characterized by a very low voltage drop and a high current-carrying capability. Once conduction has been initiated, the gate terminal no longer has any effect. In order to turn the unit off, the anode-cathode current must be reduced to a value less than the holding current.

A signal is applied to the gates from the pulse transformer. The back swing voltage from the transformer is short circuited by diodes D2 and D3, (See Fig. 2) to avoid impressing a reverse voltage pulse on the gates.

Zener diodes DZ1 and DZ2 protect the Thyristor from transient voltages which might otherwise cause premature conduction or might damage the units.

Resistor-capacitor combinations R2-C2 and R3-C3 provide a path for "turn on" current to flow for approximately one millisecond. This allows time for holding current to build up in an inductive load such as a trip coil.

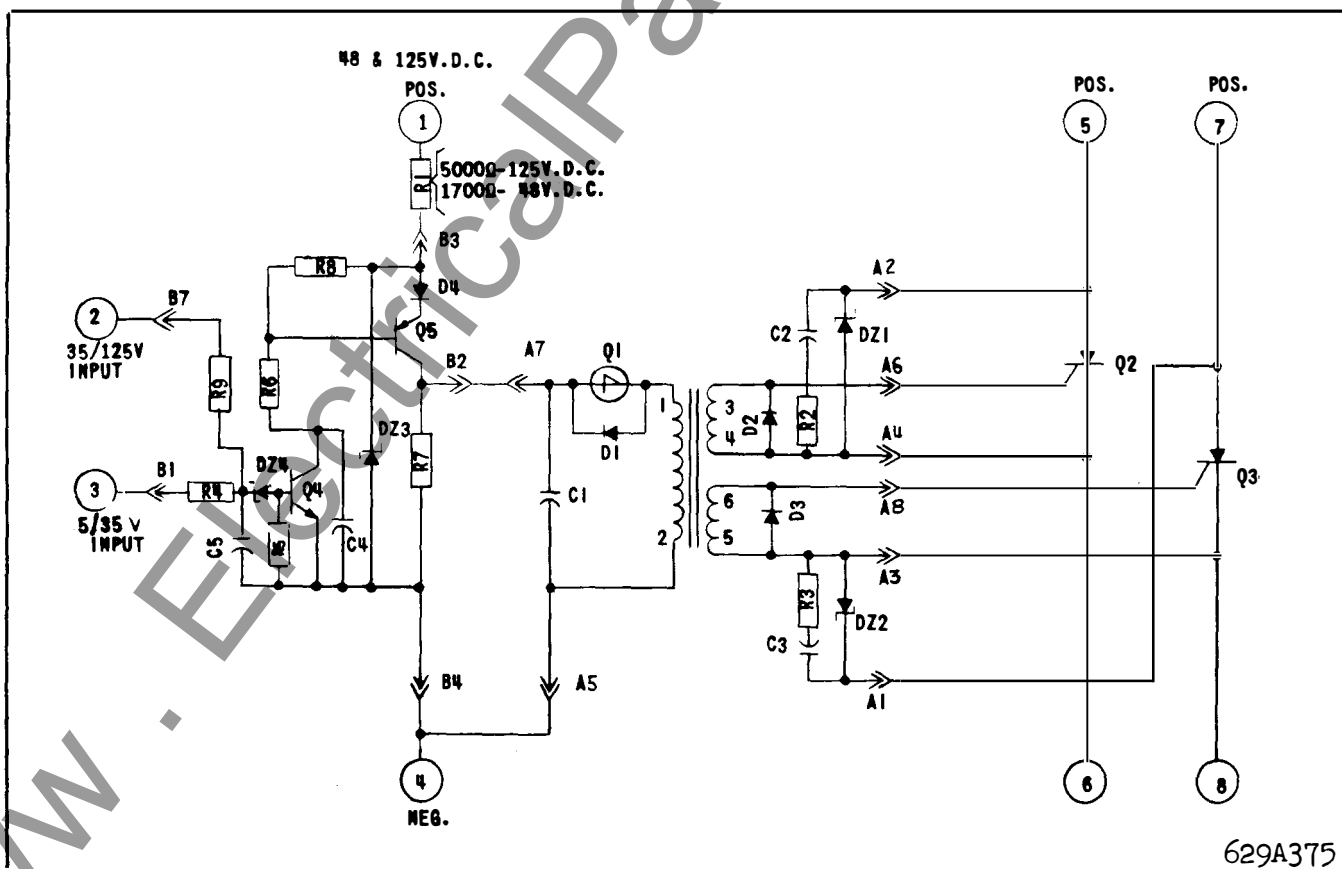

Fig. 2. Internal schematic for the type SAR relay with two outputs. for single output the circuitry associated with 7 and 8 may be omitted.

## TYPE SAR RELAY

### Bridge Rectifier Output

The SAR-2 bridge rectifies the output of the pulse transformer to charge up capacitors C2 and C3 and produces a positive voltage at terminals 5 and 7. When the input signal is removed and the pulse circuit is deenergized, voltage across capacitors C2 and C3 is discharged through resistors R2 and R3 respectively within 10 milliseconds to provide a fast turn-off feature.

### CHARACTERISTICS

The SAR and SAR-2 will receive an input signal from 5 volts d.c. to 125 volts d.c. and provide one or two isolated outputs. However, the SAR-1 has only a high voltage input. The SAR, SAR-1 and

SAR-2 relays will establish an output within 0.25 milliseconds after the input signal is applied.

It should be noted that the SAR and SAR-1 differ from mechanically operated contacts. A certain minimum load current must flow before the Thyristor will latch on. If the minimum turn on current is not established during the first millisecond after the first gate pulse is received, the unit will not latch on. However, it will permit voltage to be applied to the load for the duration of each gate pulse.

The SAR-2 output is a function of the connected load and reaches 14 milliwatts when connected to a load of approximately 2500 ohms as shown in Figure 9.

#### Specifications:

UNIT	SAR	SAR-1	SAR-2
Operating Voltage	125V d.c.	---	125V d.c.
Operating Current	20 MA	---	20 MA
Standby Tripping	25 MA	25 MA	25 MA
Temperature Range	-50°C to +85°C		
Input Signal Voltage	5 to 35V d.c. 35 to 125V d.c.	Rated d.c. volts	5 to 35V d.c. 35 to 125V d.c.
Output per Circuit			
Ambient Temperature	25°C	50°C	75°C
(3 cycle Breaker) (50MS Surge)	60 Amps	49 Amps	37 Amps
(5 cycle Breaker) (83MS Surge)	54	44	33
Continuous	6.5	4.5	3
Load Requirements	$\frac{V_{dc}}{R_{load}} = .25 \text{ amp or more}$ $\frac{L_{Henry}}{R_{load}} = .02 \text{ or less}$		
			See Figure 9

#### \* Thyristor

Max forward leakage current 125°C = 8 ma D.C.  
 Max reverse leakage current 125°C = 8 ma D.C.  
 Max forward voltage drop at 10 amps 25°C 1.6 volts.

Typical forward leakage at 85°C = .07 ma D.C.  
 Typical forward leakage at 85°C = .07 ma D.C.

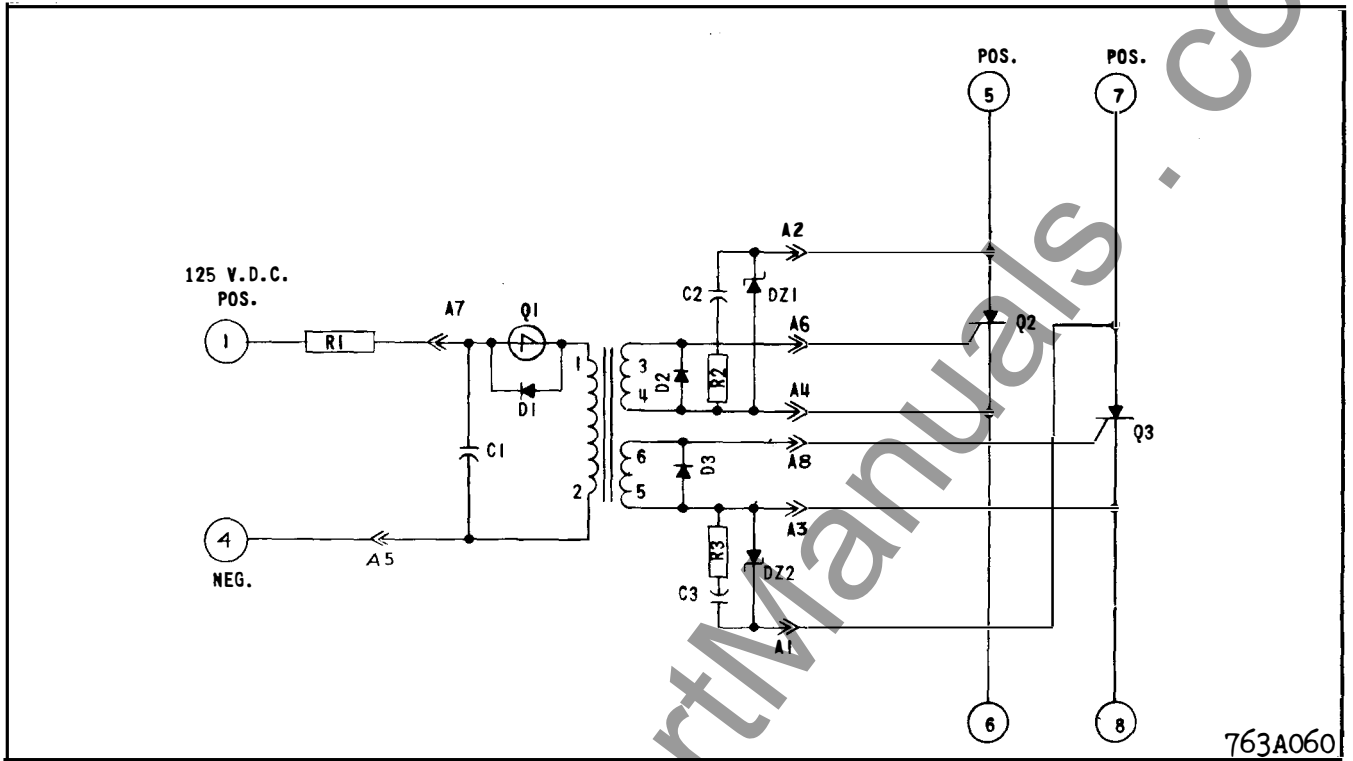

Fig. 3. Internal schematic for the type SAR-1 relay with two outputs. For single output the circuitry associated with 7 and 8 may be omitted.

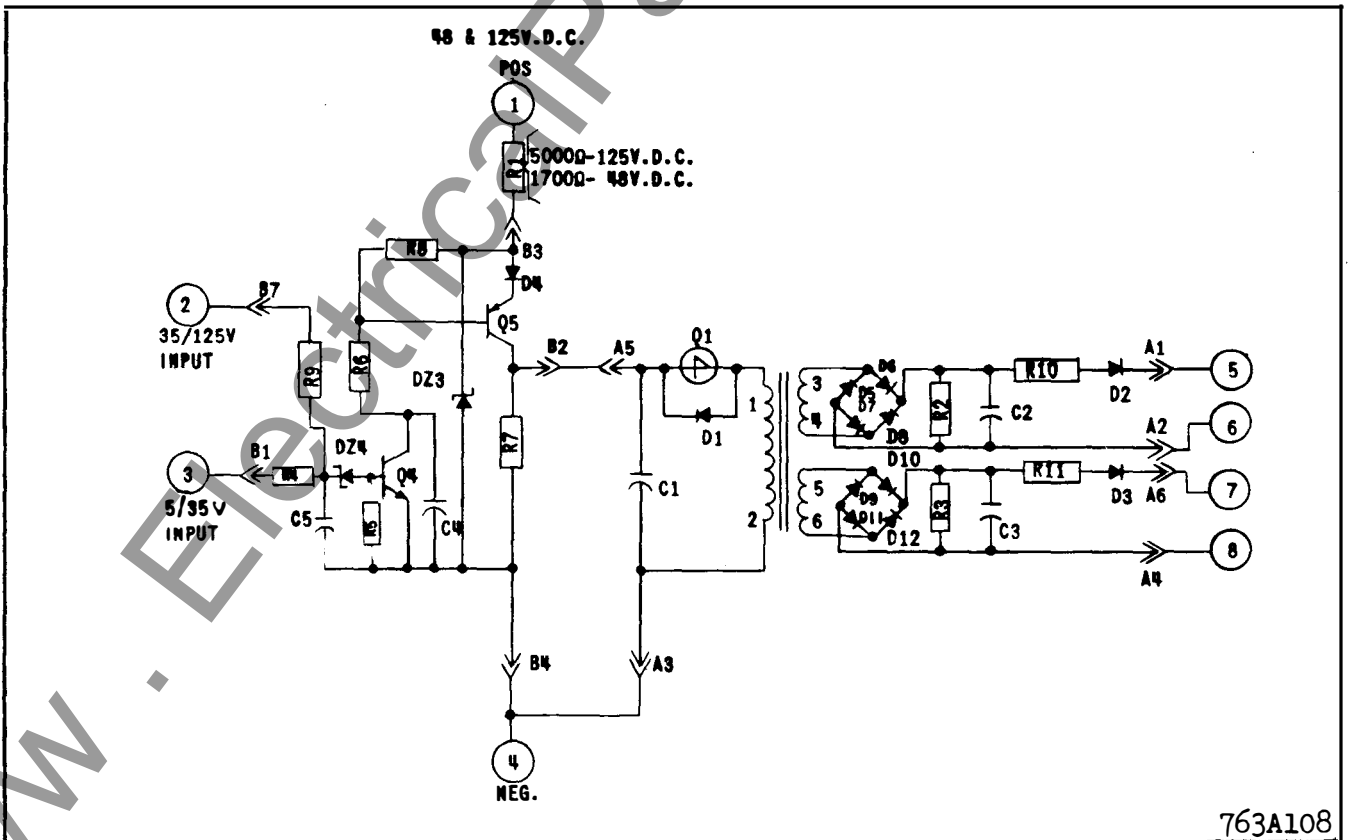

Fig. 4. Internal schematic for the type SAR-2 relay.

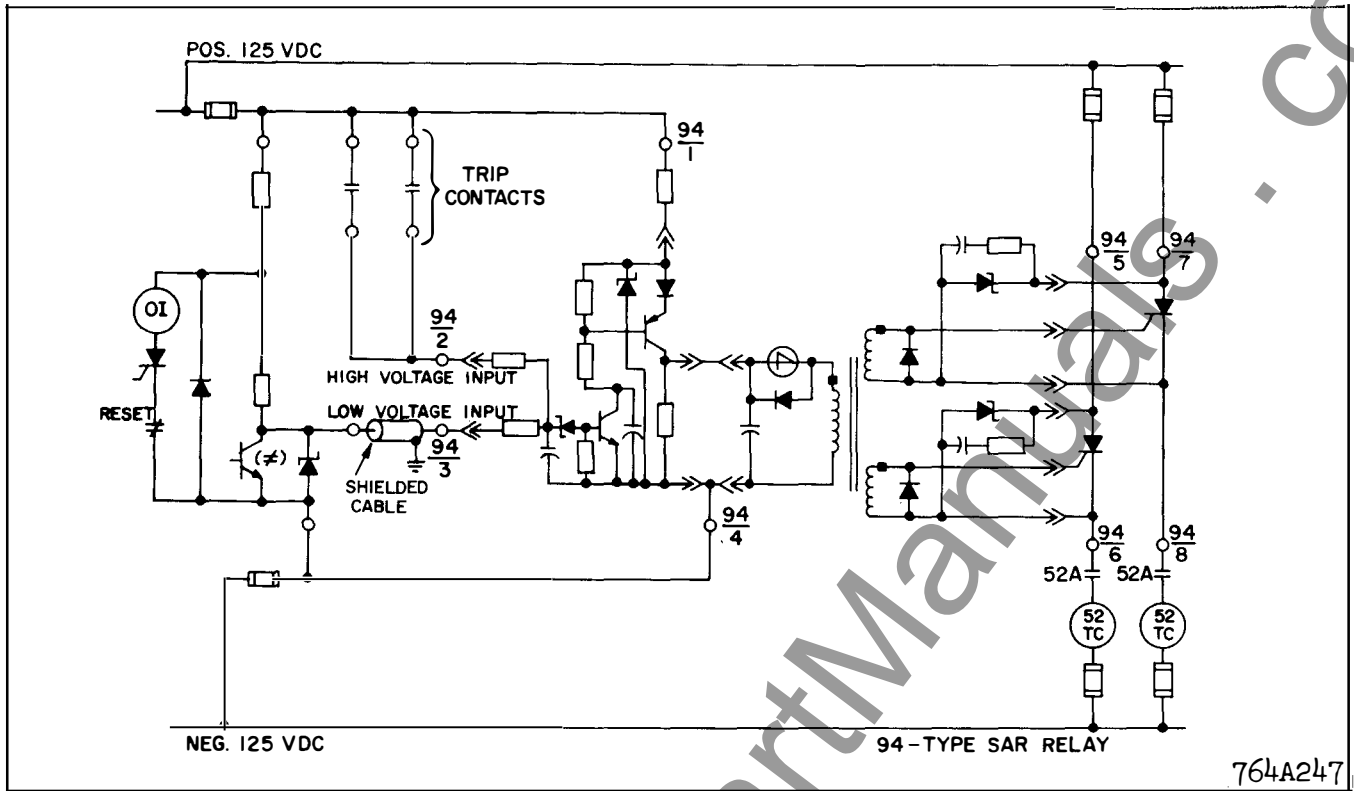

Fig. 5. External schematic for the type SAR relay.

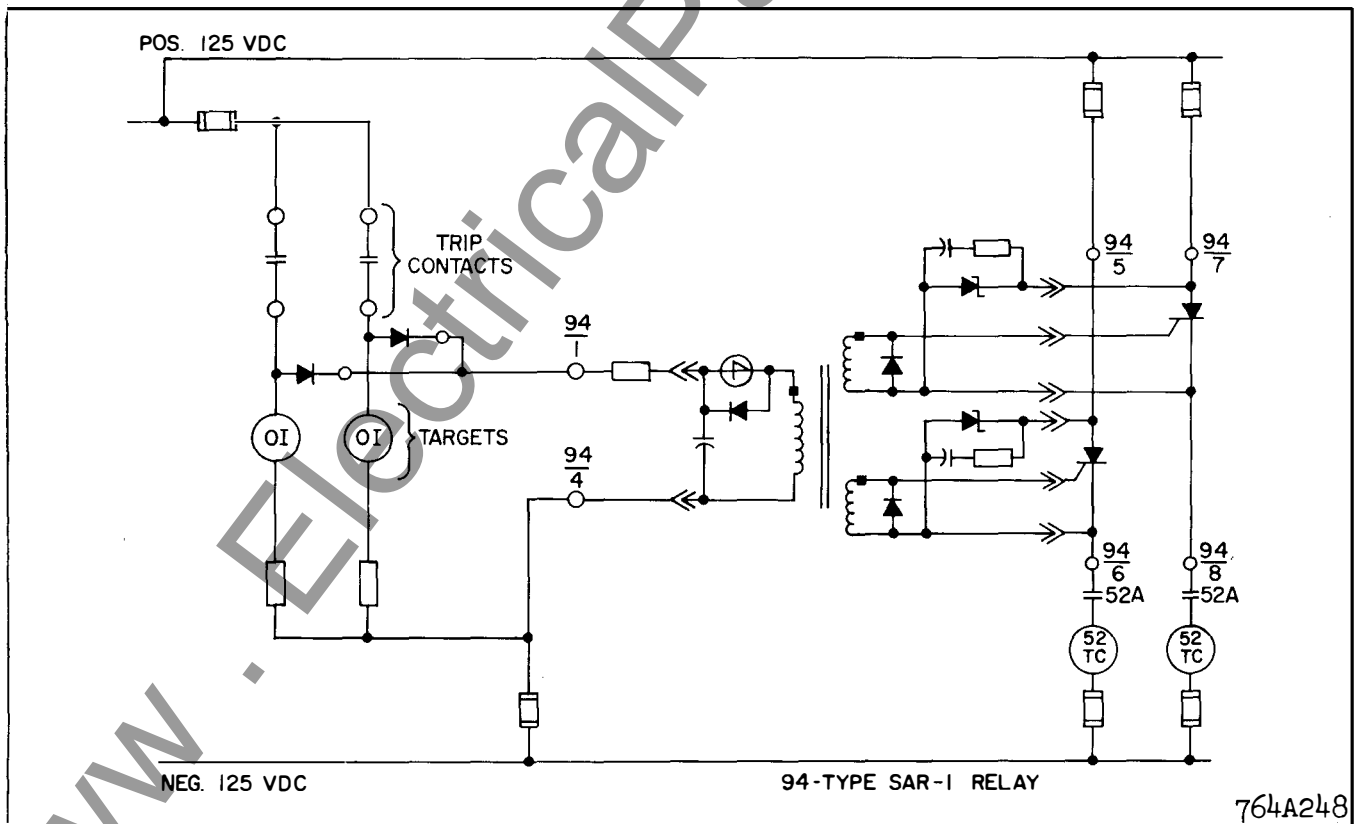

Fig. 6. External schematic for the type SAR-1 relay.

**INSTALLATION**

The units should be mounted on switchboard panels or their equivalent in a location free from dirt, moisture, and heat. Mount the units by means of two mounting screws directly to the panel. For outline and drilling refer to fig. 11.

**ADJUSTMENTS & MAINTENANCE**

**Acceptance Tests**

1. Connect the unit as shown in Figure 10.
2. Close switch S3 and no output should occur.

**TABLE I**  
**TROUBLE SHOOTING PROCEDURE FOR THE**  
**TYPE SAR RELAY**

Refer to Part A of Fig. 10.

Step in acceptance failed by the relay	CONDITION	POSSIBLE CAUSE
2	Output of the lamp at terminal 6 of the relay	1. DZ1 shorted 2. Q2 shorted
2	Output of the lamp at terminal 8 of the relay	1. DZ2 shorted 2. Q3 shorted
3	Both outputs operate	1. Q4 shorted 2. Q5 shorted
4	No output	1. Q4 open 2. Q5 open 3. DZ3 shorted 4. Q1 open or shorted 5. Q2 and Q3 both open
Refer to fig. 2 and check voltage at B2, if voltage is not present the problem is with Q4, Q5, and/or DZ3. If voltage exists at B2, check at A6 or A8 and if voltage is not present Q1 is open or shorted.		
4	One Output occurs	1. If the output is at terminal 6 then Q3 is open.  2. If the output is at terminal 8 then Q2 is open.
5	No output after 30 seconds	1. Q1 is latched on. If this is the case Increasing R1 by 10% should correct the problem.
6 or 7	Output does not remain on	1. Q2 Malfunctioning 2. Q3 Malfunctioning

## TYPE SAR RELAY

3. Close switch S1 and only SAR-1 should have an output.
4. Close switch S2 and gradually increase the signal voltage to terminals 2 and 3 alternately to be sure an output is established by SAR and SAR-2 when the minimum voltage rating is reached or before it is reached.
5. Open S3 for 30 seconds and reclose. SAR and SAR-1 should turn on immediately.
6. Open switch S2. SAR should remain on. SAR-2 should turn off.

7. Open switch S1. SAR and SAR-1 should remain on.

8. Open switch S3 to reset SAR and SAR-1.

### Calibration

No calibration is required on the SAR, SAR-1, and SAR-2.

### Trouble Shooting

The following three tables are to aid in locating components which have malfunctioned and caused the relay to fail the acceptance tests.

**TABLE II**  
**TROUBLE SHOOTING PROCEDURE FOR THE**  
**TYPE SAR 1 RELAY**

Refer to Part B of fig. 10.

Step in Acceptance test the relay failed	CONDITION	POSSIBLE CAUSE
2	Output of the lamp at terminal 6 of the relay	1. DZ1 shorted 2. Q2 shorted
2	Output of the lamp at terminal 8 of the relay	1. DZ2 shorted 2. Q3 shorted
3	Neither output operates	1. Q1 open or shorted 2. Q2 & Q3 open
	Refer to fig. 3 and check voltage at A6 or A8 if voltage does not exist	Q1 is open or shorted.
3	One output occurs	1. If the output is at terminal 6 then Q3 is open 2. If the output is at terminal 8 then Q2 is open.
5	No output after 30 seconds.	1. Q1 latched on. If this is the case increasing R1 by 10% should correct the problem.
7	Output does not remain on	1. Q2 Malfunctioning 2. Q3 Malfunctioning

**TABLE III**  
**TROUBLE SHOOTING PROCEDURE FOR THE**  
**TYPE SAR-2 RELAY**

Refer to Part C of Fig. 10

Step in Acceptance test Failed by the relay	CONDITION	POSSIBLE CAUSE
3	Both outputs operate	1 Q4 shorted 2 Q5 shorted
4	No Output	1 Q4 open 2 Q5 open 3 DZ3 shorted 4 Q1 open or shorted 5. Both diode bridges open
Refer to Fig 4 and check for voltage at B2, if voltage is not present the problem is with Q4, Q5, and/or DZ3. If voltage exists at B2, check the voltage at A6 or A8 and if voltage is not present Q1 is open or shorted.		
4	One Output occurs	1. If output occurs at terminal 6 the diode bridge at terminals 7 & 8 is open.  2. If output occurs at terminal 8 the diode bridge at terminals 5 & 6 is open.

**\* ELECTRICAL PARTS LIST**

C1 = .25 MFD Capacitor  
 C2 = C3 = 2 MFD Capacitor (SAR & SAR-1)  
       = .47 MFD Capacitor (SAR-2)  
 C4 = 150 PF Capacitor  
 C5 = .005 MFD, 200V Capacitor  
 D1 through D12 = 200 volt diode CER-69  
 DZ1 = DZ2 = 200V 1W Zener Diode IR200  
 DZ3 = 33V, 10W Zener Diode  
 DZ4 = 3.9V  $\pm$  5% Zener Diode IN748A  
 Q1 = 20V 4-layer diode 4EX562  
 Q2 = Q3 = 2N1850A Thyristor  
 Q4 = 2N699 Transistor  
 Q5 = 2N1132 Transistor  
 R1 = 5,000 ohms 25W

R2 = R3 = 470 ohms 1W (SAR & SAR-1)  
       = 22K ohms 1/2W (SAR-2)  
 R4 = 1.5K ohms 1/2W  
 R5 = 10K ohms 1/2W  
 R6 = 4.7K ohms 1/2W  
 R7 = R8 = 22K ohms 1/2W  
 R9 = 47K ohms 1/2W  
 R10 = R11 = 100 ohms 1/2W

**RENEWAL PARTS**

Repair work can be done most satisfactorily at the factory. However, interchangeable parts can be furnished to the customers who are equipped for doing repair work. When ordering parts, always give the complete nameplate data



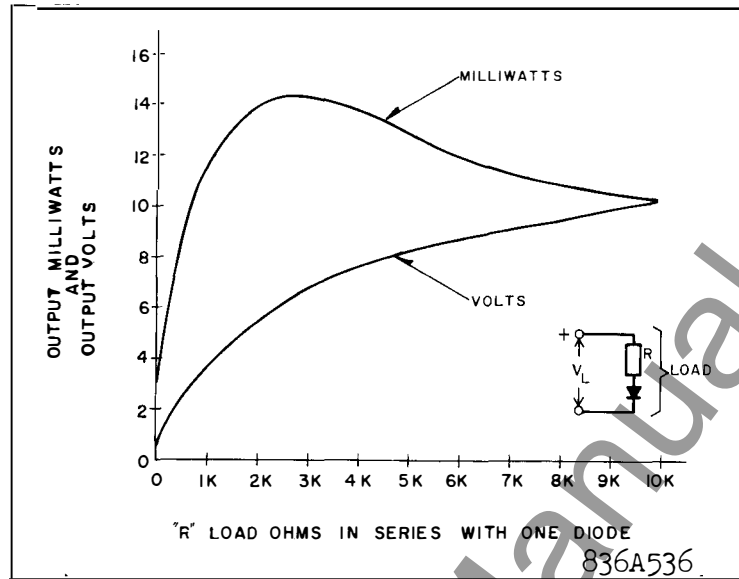

Fig. 9. Typical output characteristics of the type SAR-2 auxiliary relay.

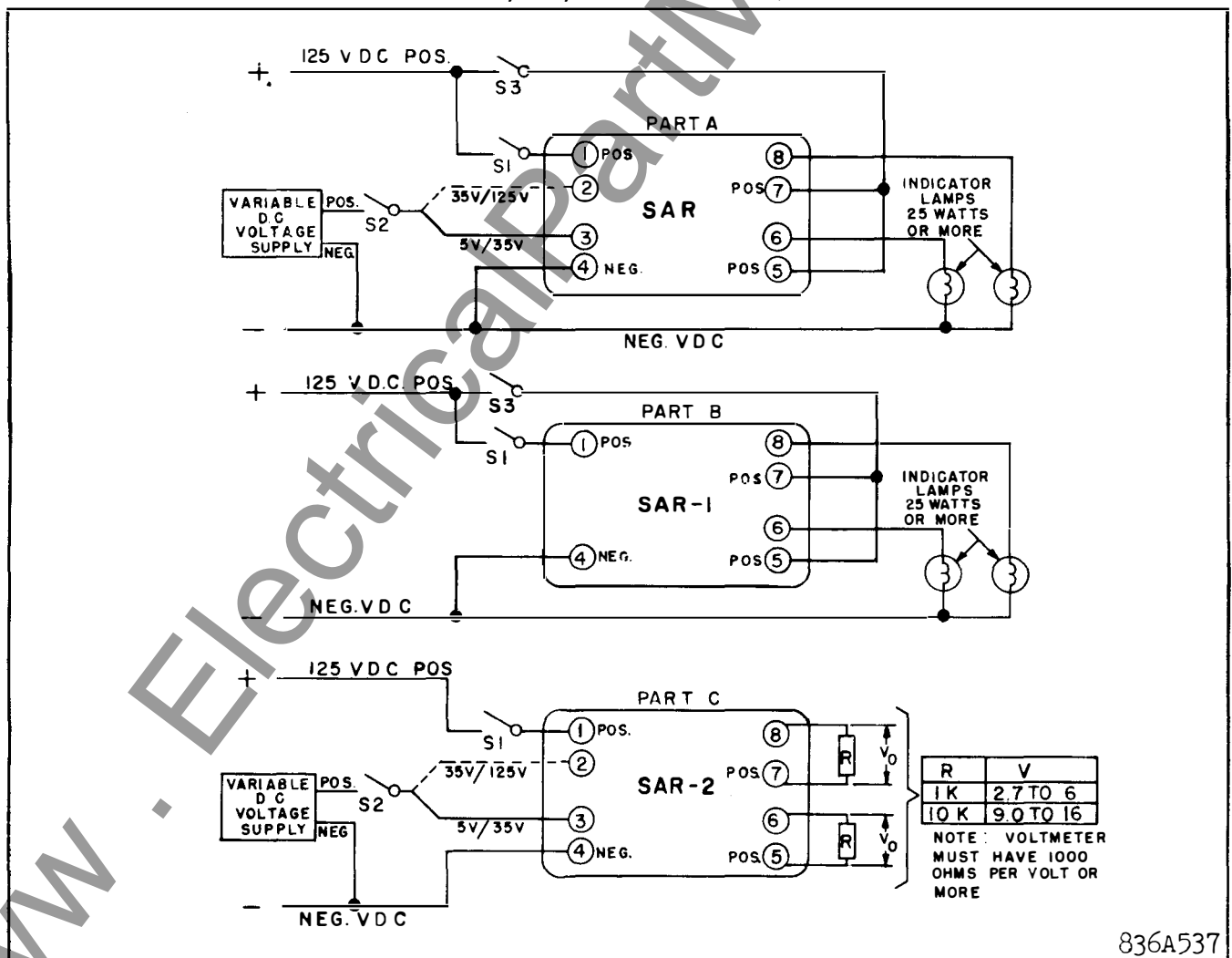

Fig. 10. Test connections for the type SAR, SAR-1, and SAR-2 relays.

836A537

TYPE SAR RELAY

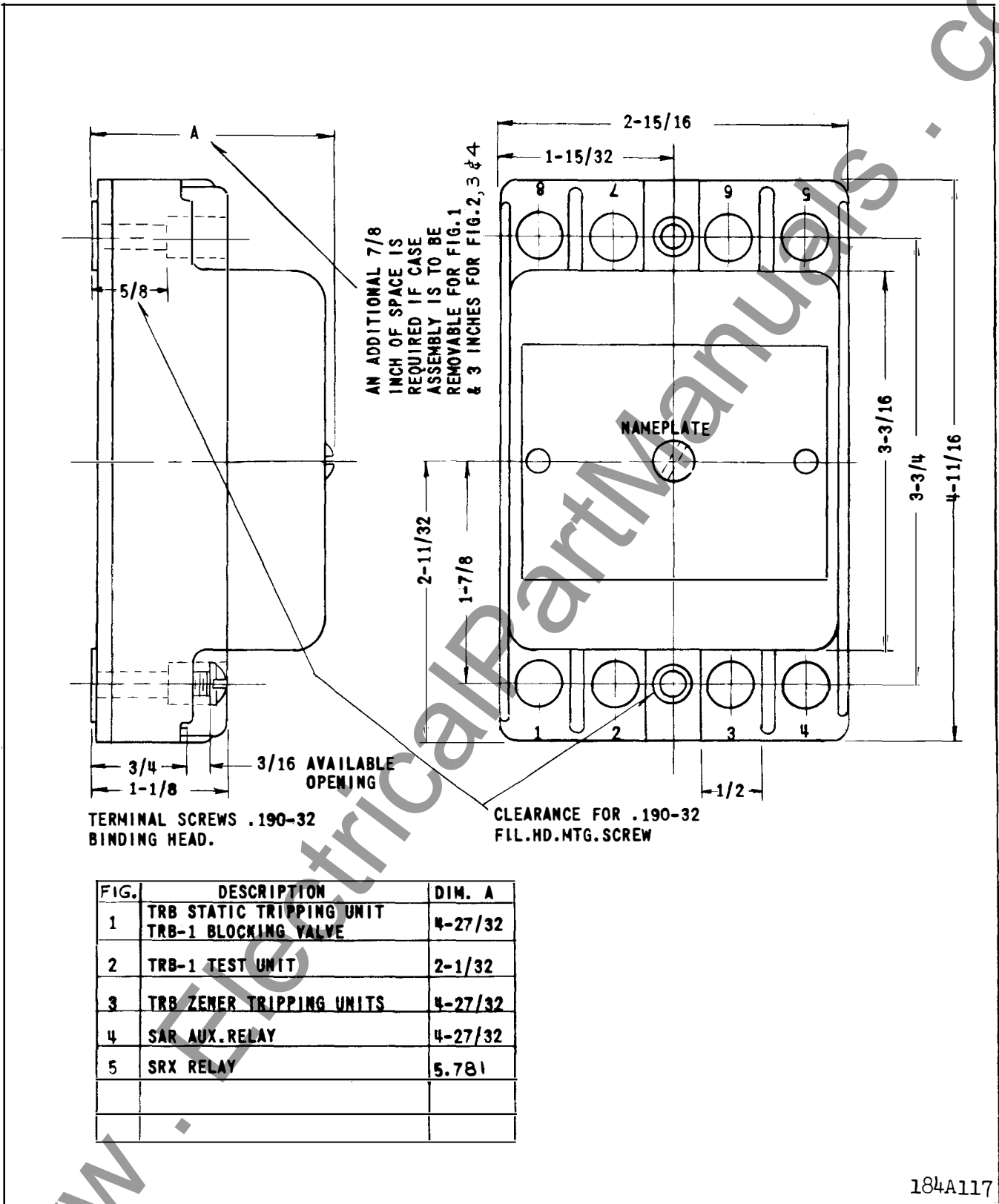

Fig. 11. Outline and drilling plan for the type SAR, SAR-1 and SAR-2 relays.

**WESTINGHOUSE ELECTRIC CORPORATION**  
**RELAY-INSTRUMENT DIVISION**

**NEWARK, N. J.**

Printed in U.S.A.