



INSTALLATION • OPERATION • MAINTENANCE I N S T R U C T I O N S

TYPE QQS PHASE SELECTOR RELAY FOR SINGLE-POLE CARRIER RELAYING

CAUTION: Before putting relays into service, remove all blocking which may have been inserted for the purpose of securing the parts during shipment, make sure that all moving parts operate freely, inspect the contacts to see that they are clean and close properly, and operate the relay to check the settings and electrical connections.

APPLICATION

The type QQS relay operates on negative and zero sequence currents to select the faulted phase when a single phase-to-ground fault occurs on the protected transmission line. The zero sequence current is obtained from the neutral of the line current transformers, and the negative sequence current from an external three-phase filter supplied with the relay.

CONSTRUCTION AND OPERATION

⊕ The type QQS relay consists of an external three-phase negative sequence filter, three-phase selector elements, a telephone type relay, and three indicating contactor switches which are mounted in the case.

A. Phase Selector Elements

⊕ The phase selector element is a product induction cylinder type unit operating on the interaction between the polarizing circuit flux and the operating circuit flux. The operating circuit flux is obtained from the output of the negative sequence current filter and the polarizing circuit flux is obtained from the zero sequence component of fault current.

Mechanically, the phase selector element is composed of four basic components: a die-cast aluminum frame, an electromagnet, a moving element assembly, and a molded bridge.

The frame serves as the mounting structure for the magnetic core. The magnetic core which houses the lower pin bearing is secured to the frame by a locking nut. The bearing can be replaced, if necessary, without having to remove the magnetic core from the frame.

The electromagnet has two series-connected polarizing coils mounted diametrically opposite one another; two series-connected operating coils mounted diametrically opposite one another; two magnetic adjusting plugs; upper and lower adjusting plug clips and two locating pins. The locating pins are used to accurately position the lower pin bearing, which is mounted on the frame, with respect to the upper pin bearing, which is threaded into the bridge. The electromagnet is secured to the frame by four mounting screws.

The moving element assembly consists of a spiral spring, contact carrying member, and an aluminum cylinder assembled to a molded hub which holds the shaft. The shaft has removable top and bottom jewel bearings. The shaft rides between the bottom pin bearing and the upper pin bearing with the cylinder rotating in an air gap formed by the electromagnet and the magnetic core. The stops for the moving element contact arm are an integral part of the bridge.

The bridge is secured to the electromagnet and frame by two mounting screws. In addition to holding the upper pin bearing, the bridge is used for mounting the adjustable stationary contact housing. The stationary contact housing is held in-position by a spring type clamp. The spring adjuster is located on the underside of the bridge and is attached to the moving contact arm by a spiral spring. The spring adjuster is also held in place by a spring type clamp.

With the contacts closed, the electrical connection is made through the stationary contact housing clamp, to the moving contact, through the spiral spring out to the spring adjuster clamp.

SUPERSEDES I.L. 41-928.1B, dated March 1970

⊕ Denotes change from superseded issue.

EFFECTIVE NOVEMBER 1976

B. Indicating Contactor Switch Unit (ICS)

The indicating contactor switch is a small d-c operated clapper type device. A magnetic armature, to which leaf-spring mounted contacts are attached, is attracted to the magnetic core upon energization of the switch. When the switch closes, the moving contacts bridge two stationary contacts, completing the trip circuit. Also during this operation two fingers on the armature deflect a spring located on the front of the switch, which allows the operation indicator target to drop. The target is reset from the outside of the case by a push rod located at the bottom of the cover.

The front spring, in addition to holding the target, provides restraint for the armature and thus controls the pickup value of the switch.

C. Telephone-Type Relay

The X3 relay is a telephone type relay with slow drop-out characteristics. A solenoid attracts an iron right-angle bracket which in turn operates a set of break and make contacts. Dropout delay is obtained by the air gap and adjustment between the solenoid core and the armature, and the copper slug on the core. A dropping resistor is connected in series with the X3 relay for 250 V.D.C.

D. Three Phase Negative Sequence Filter

The filter consists of three mutual reactors each with three windings connected as shown in Dwg. 17-D-3325. With unbalanced three-phase currents flowing in the input terminals, the output voltage and current will be proportional to the negative sequence components of the unbalanced input.

CHARACTERISTICS

- ⊕ The type QQS relay is an auxiliary relay used in the carrier relaying scheme with the types KD10, KR4-4, & KA-4 relays.

The minimum pick-up of the type QQS relay is 1 ampere and the maximum 3I₀ amperes is 100 amperes.

This is the total phase current passed through the filter and relay to neutral with the other two phase currents zero. The corresponding negative and zero sequence values are each one third of the values given above.

The negative sequence coils of the type QQS relay are normally connected in star to terminals A', B', and C' of the negative sequence filter. The neutral of this star should not be grounded. The terminals A'', B'', and C'' should be connected together to the neutral of the main current transformers. It is important that no other elements be connected between A'', B'' and C'' and the star or neutral point.

The alternate connection is used where other equipment must be connected between A'', B'' and C'' and the neutral point. In this case the negative sequence coils are connected between terminals A'A'', B'B'' and C'C''. With this connection zero sequence current must be eliminated or by-passed around the filter. Delta current is not satisfactory because it causes an undesirable phase shift in the filter.

INSTALLATION

The relays should be mounted on switchboard panels or their equivalent in a location free from dirt moisture, excessive vibration, and heat. Mount the relay vertically by means of the four mounting holes on the flange for semi-flush mounting or by means of the rear mounting stud or studs for projection mounting. Either a mounting stud or the mounting screws may be utilized for grounding the relay. The electrical connections may be made directly to the terminals by means of screws for steel panel mounting or to the terminal studs furnished with the relay for thick panel mounting. The terminal studs may be easily removed or inserted by locking two nuts on the stud and then turning the proper nut with a wrench.

For detailed FT case information refer to I.L. 41-076.

ADJUSTMENTS AND MAINTENANCE

The proper adjustments to insure correct operation of this relay have been made at the factory and should not be disturbed after receipt by the customer. If the adjustments have been changed, the relay taken apart for repairs or if it is desired to check the adjustments at regular maintenance periods, the instructions below should be followed.

All contacts should be periodically cleaned. A contact burnisher S#182A836H01 is recommended for this purpose. The use of abrasive material for clean-

ing contacts is not recommended, because of the danger of embedding small particles in the face of the soft silver contact and thus impairing the contact.

Phase Selector Element

The following adjustments are made without the external three phase negative filter connected to the relay.

1. The upper pin bearing should be screwed down until there is approximately .025" clearance between it and the top of shaft bearing. The upper pin bearing should then be securely locked in position with the lock nut. The lower bearing position is fixed and cannot be adjusted.

2. The contact gap adjustment is made as follows:

With the moving contact in the normally-opened position, i.e., against the right stop on bridge, screw in the stationary contact until both contacts just close as indicated by a neon lamp in the contact circuit. Then, screw the stationary contact away from the moving contact 3/4 of a turn. The clamp holding the contact housing need not be loosened for the adjustment since the clamp utilizes a spring-type action in holding the stationary contact in position.

The set screw in the stationary contacts has been shop adjusted for optimum follow and this adjustment should not be disturbed.

The moving contact assembly has been factory adjusted for low contact bounce performance and should not be changed.

3. The sensitivity adjustment is made by varying the tension of the spiral spring attached to the moving element assembly. The spring is adjusted by placing a screwdriver or similar tool into one of the notches located on the periphery of the spring adjuster and rotating it. The spring adjuster is located on the underside of the bridge and is held in place by a spring type clamp that does not have to be loosened prior to making the necessary adjustments.

The spring is to be adjusted such that the contacts will close as indicated by a neon lamp in the contact circuit when energized with 0.5 amperes. For this test the negative sequence coils and the zero sequence coils should be connected in series to a common source. The proper polarity should be observed in applying the current.

4. The magnetic plugs are used to reverse any unwanted spurious torques that may be present when the relay is energized on current alone.

The reversing of the spurious torque is accomplished by applying 40 amperes to the negative sequence coils (zero sequence coils open-circuited) and adjusting the plugs in the following manner:

<u>Both Plugs In Condition</u>	<u>Adjustment</u>
Spurious torque in contact closing direction (Left Front View)	Right (Front-View) Plug Screwed out until spurious torque is reversed.
Spurious torque in contact opening direction (Right Front View) (Contacts remain open)	Left (Front-View) Plug screwed out until spurious torque is in contact closing direction, then the plug is screwed in until spurious torque is reversed.

Telephone-Type Relay

Energize the telephone relay, X3, by applying 80 volts d-c to terminal 18 and 19 for 125 Vd-c, and by applying 160 Vd-c to terminal 18 and 19 for 250 Vd-c. The telephone relay should operate positively.

Indicating Contactor Switch (ICS)

Close the main relay contacts and pass sufficient dc current through the trip circuit to close the contacts of the ICS. This value of current should not be greater than the particular ICS tap setting being used. The indicator target should drop freely.

The contact gap should be approximately .047" between the bridging moving contact and the adjust-

TYPE KQS PHASE SELECTOR RELAY

able stationary contacts. The bridging moving contact should touch both stationary contacts simultaneously.

Three-Phase Negative Sequence Filter

The filter is adjusted for balance at the factory and no further adjustments or maintenance should be required. With balanced three phase currents of 10 amperes, 60 cycles, phase rotation A, B, C, introduced into the input terminals as marked on Dwg. 17-D-3325. The voltage between the output terminals A', B', and C', should be zero. Use a high resistance voltmeter for this check.

Connect terminals A', B', and C', to terminals 3, 5, and 7 of the type KQS relay. Connect the relay terminals 2, 4, and 6 together. With balanced three-phase currents of 5 amperes, 60 cycles, phase rotation A, B, C, applied to the filter input terminals A, B, C, and the neutral made by connecting terminals A'', B'' and C'' together, the voltage across the relay terminals 2 and 3, 4 and 5 and 6 and 7 should be zero. Now, reverse the connections to the filter in-

put terminals A and B and check the voltage now appearing across the relay terminals. These three voltages should be substantially 0.7 volt.

With the relay and filter connected, apply 1 ampere between phase to neutral of the filter. Adjust the spring of the proper phase selector such that the contact just closes.

Apply 15 amperes between phase to neutral and check the action of the phase selector elements. The element associated with the phase being energized should operate while the other two elements should remain open.

RENEWAL PARTS

Repair work can be done most satisfactorily at the factory. However, interchangeable parts can be furnished to the customers who are equipped for doing repair work. When ordering parts, always give the complete nameplate data.

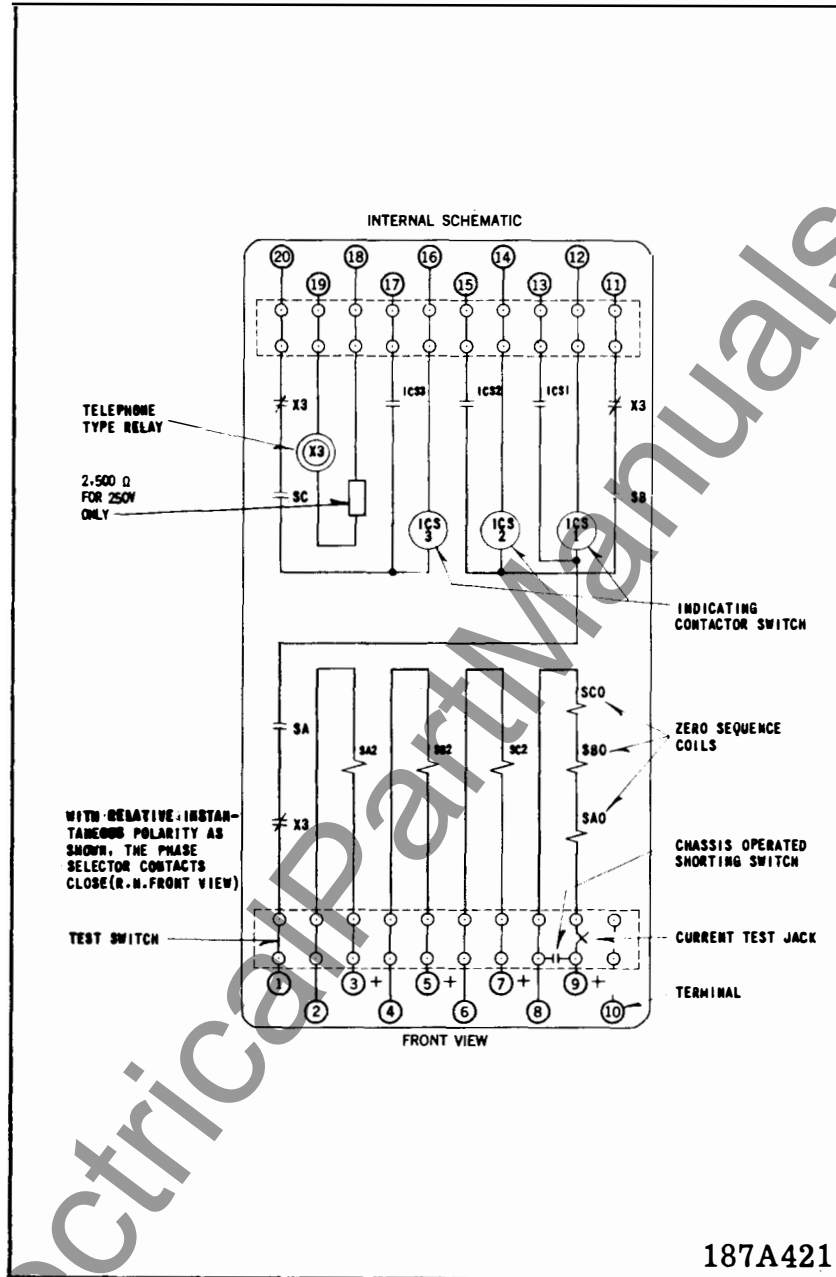

Fig. 1. Internal Schematic of the Type KQS Relay in the Type FT-42 Case for K-Dar Single Pole Relaying.

TYPE KQS PHASE SELECTOR RELAY

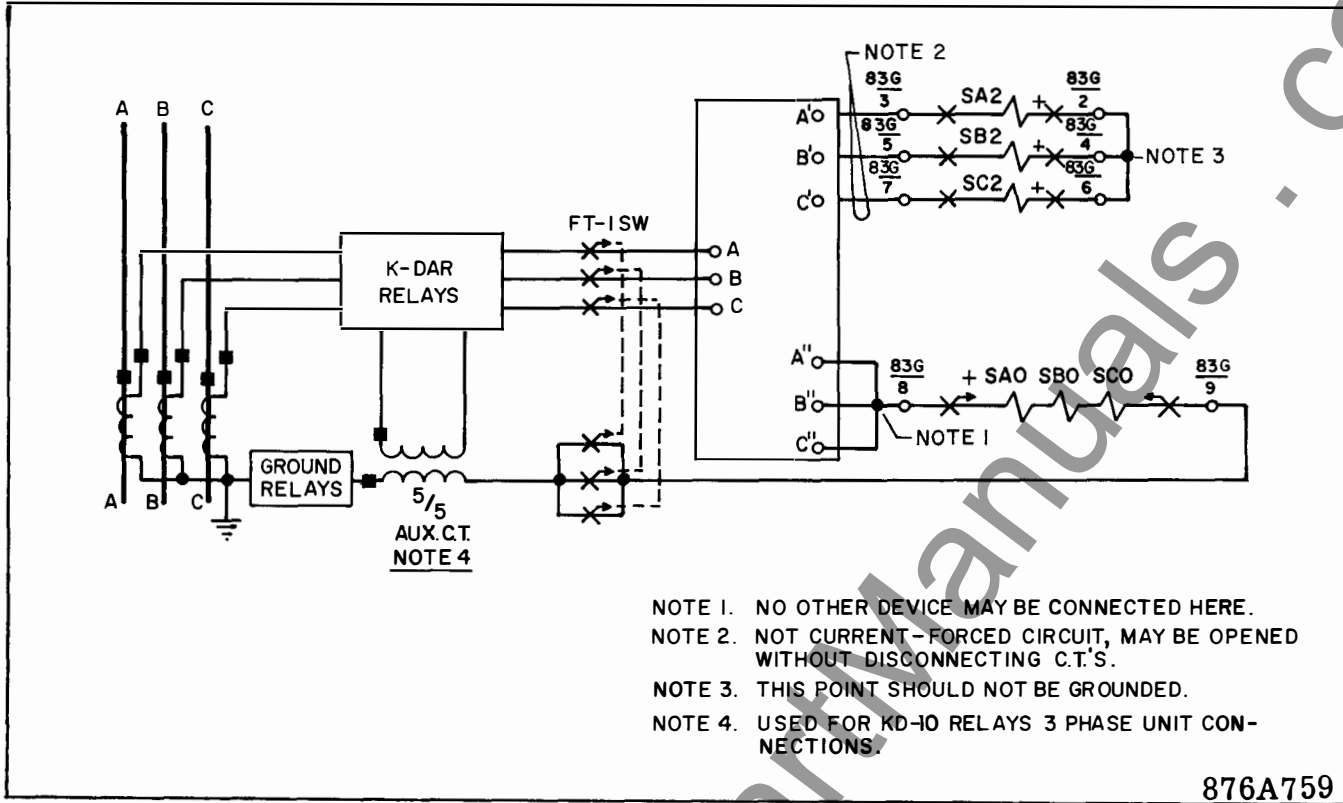

Fig. 2. AC External Connections of KQS Phase Selector Relay for K-Dar Single Pole Tripping.

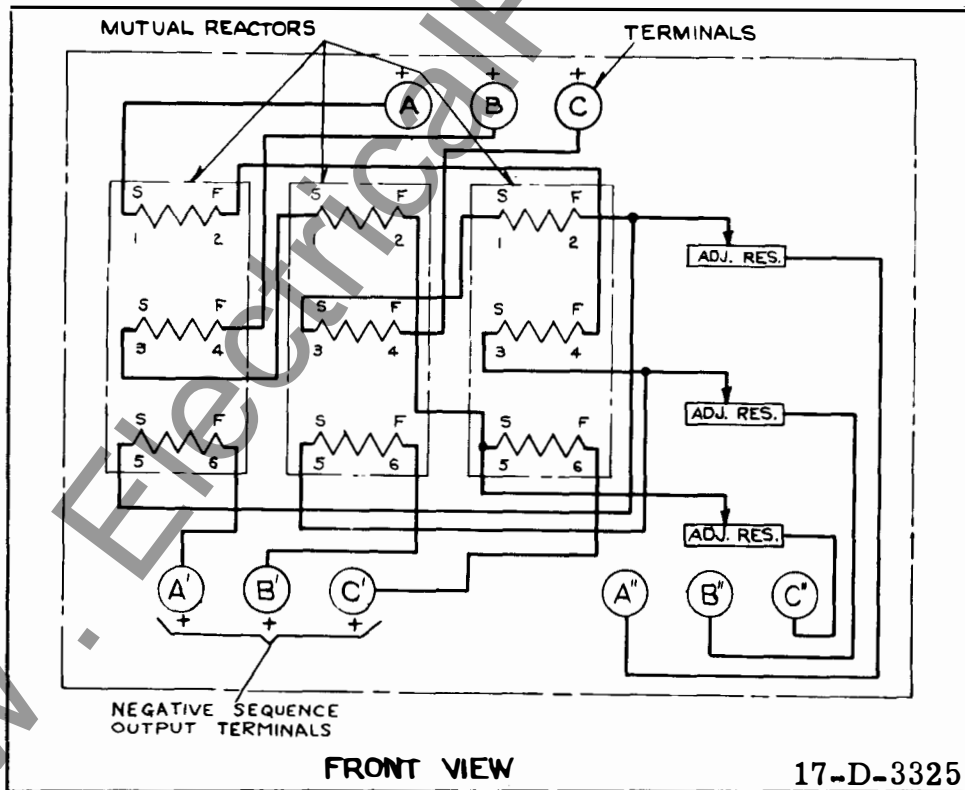

Fig. 3. Negative Sequence Filter Internal Schematic.

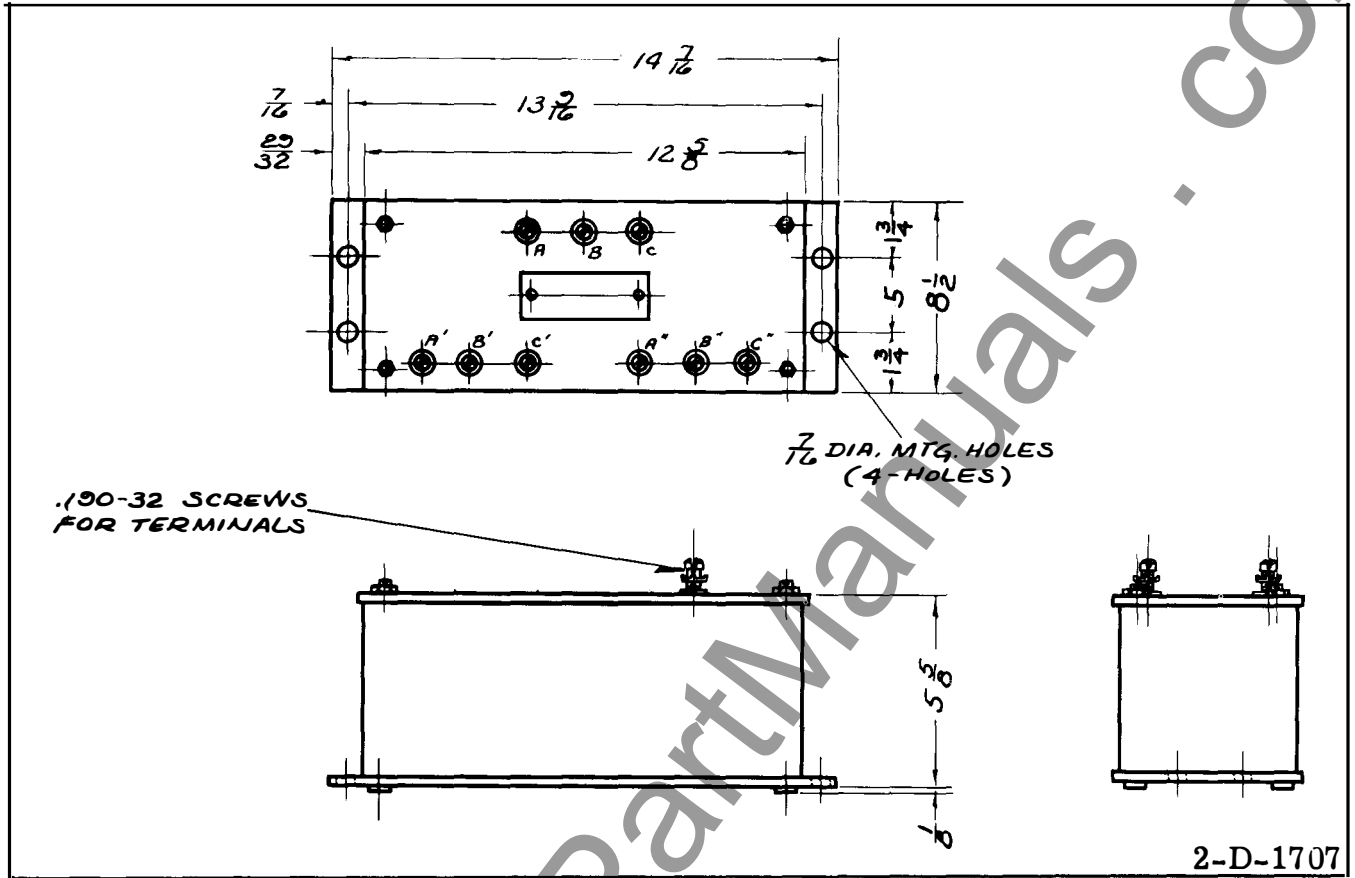
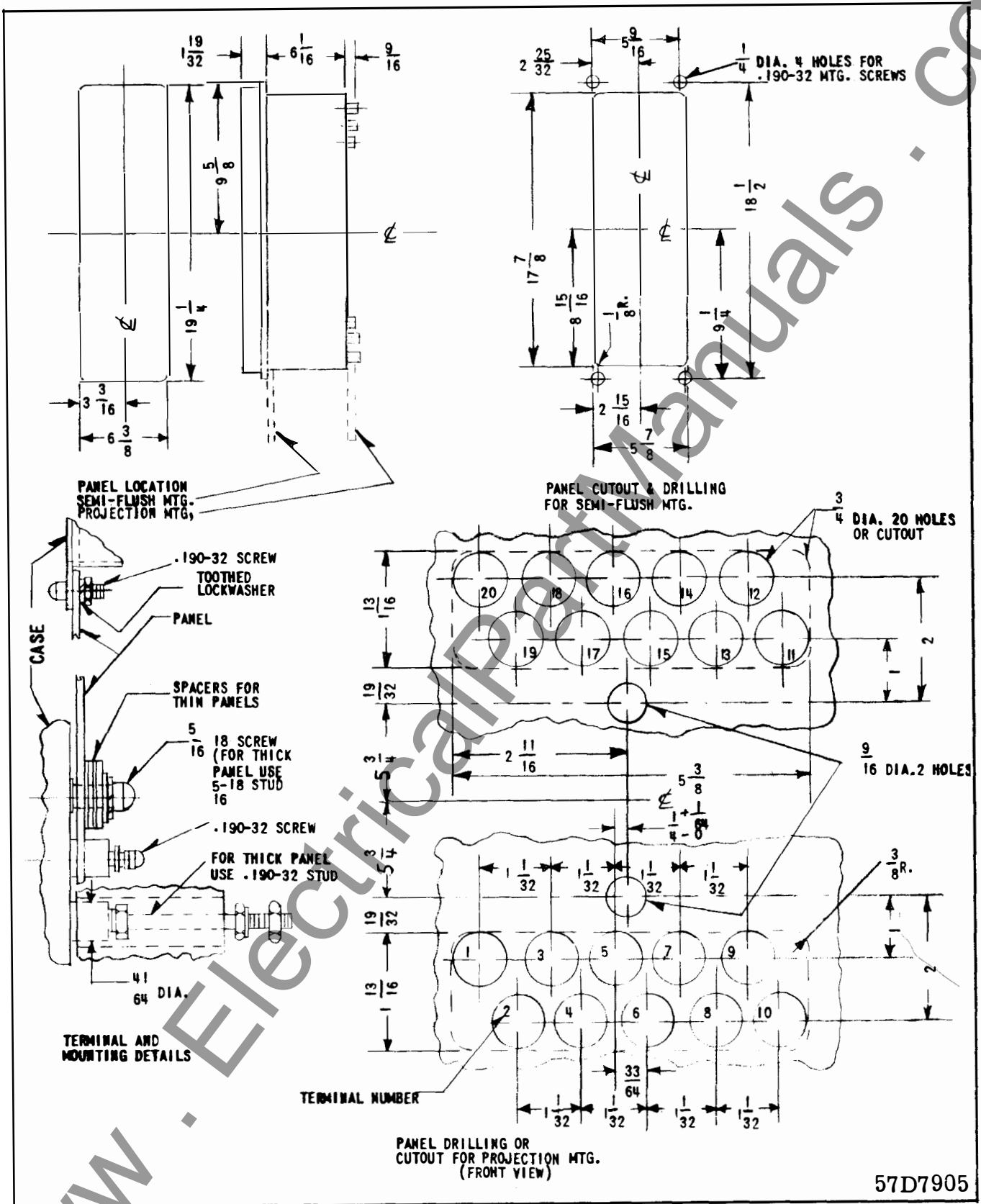

Fig. 4. Outline and Drilling Plan for Type QQS Negative Sequence Filters.

TYPE QQS PHASE SELECTOR RELAY



57D7905

Fig. 5. Outline and Drilling Plan for Type QQS Relay in the Type FT-42 Case.

WESTINGHOUSE ELECTRIC CORPORATION
RELAY-INSTRUMENT DIVISION
NEWARK, N. J.

Printed in U.S.A.