

INSTALLATION • OPERATION • MAINTENANCE I N S T R U C T I O N S

TYPE KR CARRIER RELAYING TRANSMITTER-RECEIVER

Flexitest Case Mounted —with provision for rear-mounter Voice Adapter Accessories.	Style
KR Reserve Signal Detector	470D167 GO2
250 Volt Resistor Unit	330C191 H01
Test Harness (Complete Set)	756D346 G01
Coaxial Lead	756D346 G02
Output Lead	756D346 G03
Main Harness	756D346 G04

TABLE OF CONTENTS

Introduction	Page 2	Adjustments	
Specifications	Page 2	Transmitter.....	Page 7
Description		Receiver	Page 7
General.....	Page 3	Reserve Signal Detector.....	Page 8
Mechanical	Page 3	250-Volt Resistor Unit.....	Page 8
Electrical.....		Frequency Change	Page 8
Transmitter	Page 4	Maintenance	Page 9
Receiver	Page 4	Application	Page 13
Transmitter Control Circuits.....	Page 5	Electrical Parts List.....	Page 14
Reserve Signal Detector	Page 5		
Communications	Page 5		
Relaying Control Circuits	Page 5		
Installation			
General.....	Page 6		
Connections			
External.....	Page 6		
Internal	Page 7		

LIST OF TABLES

Table	
⊕ 1 D-C Pin Jack Measurements with Reference to neg. d.c.	Page 10
⊕ 2 Transistor DC Measurements with Reference to neg. d.c.	Page 11
⊕ 3 D-C Bleeder Measurements with Reference to neg. d.c.	Page 12
4 Typical RF Signal Measurements for Receiver	Page 12
5 Typical RF Signal Measurements for Transmitter	Page 13

SUPERSEDES I.L. 41-941.1J, dated March 1974

⊕ Denotes change from superseded issue.

EFFECTIVE SEPTEMBER 1976

LIST OF ILLUSTRATIONS

Figure	References
1 Outline – Flexitest Case	540D753
2 Internal Schematic	540D780
3 Relaying Control Circuits (HZ/HZM)	1-329C704
4 Relaying Control Circuits (K-Dar)	3-329C704
5 Relaying Control Circuits (GCX/GCY).....	2-329C704
6 Component Location.....	540D781
7 Supervisory Control Receiver Connection.....	223B498
8 Connections, 48-250 volts and Supervisory Control.....	407C971
9 Transmitter Output Filter Connections	149A420
10 Transmitter Output Filter Selectivity.....	C377996
11 Reserve Signal Detector – Outline and Schematic	329C703
12 Receiver Selectivity	C377993
13 Receiver Filter Limits	C377995
14 Minimum, Channel Spacing	C377998
15 Test Harness	756D346

CAUTION The voltages encountered in this equipment are dangerous to life. To be safe, disconnect the power source and close the grounding switch when servicing the equipment.

INTRODUCTION

The Type KR Relaying Transmitter-Receiver is designed for Distance Relaying, Telemetry, Supervisory Control and Sleet Detection. Facilities are provided for a plug-in type voice adapter. The basic design is for operation from 125-volt station batteries. However, the apparatus may also be operated from 48-volt or 250-volt station batteries by means of various internal connections. These various connections as well as most of the adjustments are made at the factory, although they can be changed in the field.

Although designed primarily for operation with Westinghouse protective relays, this apparatus may also be coordinated with other types of directional-distance relays and with most other contact keyed devices.

SPECIFICATIONS

⊛ Frequency Range.....	30-k Hz to 210kHz
Channel Attenuation Rating	40-db
Transmitter Power Output	1.0 watt with a 125 V.D.C. supply. 0.5 watt with a 48-volt d-c supply.
Transmitter Harmonic Output	At least 46-db below funda- mental.
Transmitter Output Impedance.....	Matches one 60-ohm coax. cable. (Suitable for 50-70 ohm cable.)
Transmitter Output Filter Selectivity	See Fig. 10
Transmitter and Receiver Oscillator and Frequency Stability	From - 20°C to + 55°C with si- multaneous voltage variations from 105 to 140 VDC, the fre- quency remains within ±20Hz.

Permissible Battery Voltage Ripple	7-½%
Ambient Temperature Range	- 20° C to + 55° C.
Receiver Maximum Sensitivity025 volts for 10 ma. output.
Receiver Selectivity	See Fig. 12
Receiver Signal-to-Noise Ratio Requirements	12-db
Minimum Channel Spacing	See Fig. 14
Power Input	115-ma at 48 VDC, 200-ma at 125 VDC, 1.28 amperes at 250 VDC.
Carrier On-Off Keying	Requires one pair of contacts capable of keying 8-ma DC at an open circuit voltage of 125 VDC.
Weight (With Flexitest Case)	Approximately 16-lbs.

CAUTION Refer application to Westinghouse when other transmitters are to be connected to the same coax cable as certain conditions may result in damage to the output transistors.

such as potentiometers, jack, test points, crystals, transistors, etc. External connections and the Schematic Diagram are shown by Fig. 2. The numbered terminals shown as squares apply to the external terminals.

DESCRIPTION

Mechanical

This apparatus is supplied in a Flexitest case and may be either flush or projection mounted in order to match other switchboard equipment. The outline dimensions and also the drilling plan for flush and projection mounting are shown by Fig. 1. The majority of the parts are mounted on a printed circuit board. This board may be readily removed as follows:

1. Remove the two output plugs from the red and black jacks.
2. Disconnect the receiver input coaxial cable connector.
3. Loosen the two screws at the top of the board.
4. Loosen the two screws at the bottom of the board and pull them out as far as they will extend.
5. Pull board down to disengage the terminals and lift out.

The transmitter output filter may be removed by removing four mounting screws from the bottom of the case and disconnecting the coaxial cable.

Fig. 6. shows the location of major components

Provisions are made for plugging the Voice Adapter Unit in the rear of the relaying equipment. Octal socket marked X-4 on the rear of the set accommodates the adapter plug. A buckle type strap on each side of the adapter holds the unit in place after it has been plugged in. The normal projection for a rear mounted Voice Adapter is 3-inches beyond that of the relaying equipment. When the KR Relaying Unit is supplied with the adapter, a patch cord is available on separate order. This patch cord plugs into the telephone jacks on the adapter and provides an extension to a conveniently located terminal board.

The panel cutout information necessary for mounting the Reserve Signal Detector is shown by Fig. 11. This unit consists of a potentiometer and pushbutton switch mounted on a small panel, itself suitable for switchboard mounting.

For 250-volt operation, separate auxiliary resistors are required, as shown in Fig. 8.

Electrical

Transmitter

The transmitter is made of four main stages in -

cluding an oscillator, driver, power amplifier, and an output filter. In the oscillator, the crystal is operated as a resonant circuit between the collector of one transistor and the base of the other. The feedback is supplied through a capacitor from the collector of the second transistor to the base of the first transistor. The frequency is independent of voltage or temperature changes of the transistors. Thus the frequency stability is the stability of the crystal.

The input to the driver stage Q-10 is controlled by potentiometer, R-42 which also controls the transmitter power output. In HZM relaying CARRIER STOP provides about +40 volts for blocking. This is applied to Q-10 through T-6. Diode CR-5 prevents damage to the transistor when this positive voltage is applied to the collector. For CARRIER START (when in the blocked position) a small positive voltage is applied to the collector of Q-10 by means of bleeder resistors R-67 and R-68.

The power amplifier consists of two transistors Q-12 and Q-15, which are operated as class B amplifiers in push-pull. Resistors R-52 and R-55 are for stabilization.

The output transformer, T-7, matches coaxial cables of 50 to 70 ohms.

Resistor R-66 tends to keep the source impedance constant to permit proper tuning of the output filter.

The output filter consists of coils L-1 and L-2, capacitors C-19 through C-22. The filter is tunable, and is provided to attenuate harmonics and other spurious outputs. It should be noted that the filter contains no shunt elements, resulting in a reverse impedance free of "across the line" resonances.

Receiver

The receiver is a superheterodyne in order to obtain constant selectivity regardless of the channel frequency. (See Fig. 12) The major stages include an input filter, attenuator, oscillator, mixer, IF filters, IF amplifiers, detector and a D-C power output stage.

The receiver sensitivity is adjusted by means of the continuously variable input control R-1 and by connecting or disconnecting resistors R-73 and R-74 in the IF stages.

The receiver oscillator (Q-2 and Q-3) is basic-

ally the same as the transmitter oscillator. The frequency is 20-kHz above the incoming signal frequency.

The receiver channel frequency is determined by the input filter and the oscillator crystal. The frequency may be changed readily since both the filter and the crystal are plug-in components.

Mixing is accomplished by feeding the incoming signal to the emitter and the receiver oscillator signal to the base of the mixer Q-1. Mixer oscillator requirements are met through adjustment of potentiometer R-4. Injection into two separate elements, base and emitter, provides a circuit capable of handling greater signal level variations than one in which injection is made into only a single element such as the base.

This receiver uses an IF frequency of 20-kHz. The overall selectivity is determined primarily by the IF filter FL-2. Typical characteristics of this filter are shown in Fig. 13. The IF amplifier consists of transistors Q-4, Q-5 and Q-6.

The detector is a full wave bridge rectifier. This rectifier in conjunction with the IF amplifier Q-6, provides the necessary power to drive the D-C power output stage Q-7. The final output stage Q-7 will supply approximately 18 milliamperes to a standard 1700 ohms distance relay RRH coil and its associated 500 ohm alarm coil. It may also be used to drive other relay coils such as is shown by Fig. 7, Supervisory Control Connections.

Transmitter Control Circuits

In the standby condition, although the oscillator is running, the transmitter driver has no emitter bias which results in no output.

Positive voltage applied to terminal 15 supplies this bias through a voltage dividing network, and transmitter output results. The actual configuration of the network is a function of supply voltage and application (Relaying, Telemetry, etc.) and is discussed in the Adjustments section.

Output may be stopped in several ways. The method used with K-DAR relays is to remove the positive voltage applied to terminal 15. In the case of distance relaying with Westinghouse HZ/HZM relays, application of a positive voltage to terminal

18 will stop the transmitter output. Output may also be stopped by removal of negative battery from terminal 18.

Reserve Signal Detector

The Reserve Signal Detector is shown by Fig. 11. Effectively R-1 is a remote transmitter output control. This control is obtained through varying the driver Stage (Q-10) emitter bias, and is effective over a 25-db range of transmitter output. The detector is switched into service by S-1. By adjusting R-1 for a given receiver relay current at the far end of the channel, a relative measure of the channel attenuation may be obtained. This is discussed further in the section on Adjustments.

Communications

The transmitter output is reduced approximately 6-db when the Type KR voice adapter attachment is used. Relaying takes preference, and full output is obtained when full voltage is supplied to terminal 15.

Relaying Control Circuits

Figs. 3, 4 and 5 show simplified diagrams of the relaying control circuits.

1. K-DAR and GCY Relaying (Figs. 4 and 5)

The control of the carrier set is obtained through the CARRIER START and CARRIER STOP contacts. These contacts are shown in their normal standby condition.

The K-DAR or GCY relays operating from the voltage and current on the transmission line, detect and determine the direction of a line fault and thereby control the carrier transmitter and receiver.

The control of the carrier set is such as to start the transmission of carrier when fault power on the transmission line is flowing out of the line section being protected. Conversely, when fault power is flowing into this line section, the control is such as to block the transmitter and keep it from being turned on by secondary functions such as reserve signal detection and communication, should these functions be in use at the same time. Should carrier be received from the remote station, the hold coil and alarm coil will energize through transistor Q-7 in the receiver.

When carrier start operation occurs, the CARRIER

START contact opens applying a positive voltage (see Figs. 4 and 5) to terminal 15 of the carrier set. This puts a potential on the driver stage in the transmitter and also applies proper bias for the power amplifier.

When a carrier stop operation occurs, the CARRIER STOP contact closes, which removes B+ (terminal 15) from the driver and the power amplifier stages in the transmitter. CARRIER STOP, terminal 18, on the carrier set is permanently connected to terminal 14, for K-DAR and GCY relaying.

2. HZM Relaying (Fig. 3)

The control of the carrier set is effected by the CARRIER START and the CARRIER STOP contacts. These contacts are shown in their normal standby condition.

The HZ-HZM relays operating from the voltage and current on the transmission line, detect and determine the direction of a line fault and thereby control the carrier transmitter and receiver.

The control of the carrier set is such as to start the transmission of carrier when fault power on the transmission line is flowing out of the line section being protected. Conversely, when fault power is flowing into this line section, the control is such as to block the transmitter and keep it from being turned on by secondary functions such as reserve signal detection and communication, should these functions be in use at the same time. Should carrier now be received from the remote station, the hold coil and alarm coil will energize through transistor Q-7 in the receiver.

When carrier start operation occurs, the CARRIER START contact closes applying the full battery supply voltage to terminal 15 of the carrier set. This puts a potential on the driver stage in the transmitter and also applies proper bias for the power amplifier.

When a carrier stop operation occurs, the CARRIER STOP contact opens. This applies a positive voltage (see Fig. 3) to terminal 18 which blocks the driver stage and the power amplifier stage

It is possible under certain conditions that the signals from two transmitters, attempting to block a third receiver, would be of such amplitude, phase and frequency as to cause the RRH coil current to "pulsate". It would then be possible to have a false trip.

In the case of the KR set for relaying 3-terminal lines, the transmitter frequencies (to avoid this possibility of false trip) should be separated by 100 Hz. All receivers and one transmitter would be at the desired center frequency. One of the other transmitters would be 100 Hz above, the other 100 Hz below this center frequency.

- 18Carrier Stop for HZM Relaying
- 19 Pos. DC
- 20 Relay Coil

INSTALLATION

General

Upon receipt of a unit, whether shipped separately or in an assembly, an immediate inspection should be made. Carefully check for damage or shortages.

For necessary clearances and mounting dimensions, see the following illustrations:

- Flexitest Case Mounting Fig. 1
- Reserve Signal Detector Fig. 11

Connections

External

The external connections will vary slightly depending on the application, but in general will be as follows: (Refer to the Schematic Diagram, Fig. 2)

- Terminals 11 Ground
- 12 Coaxial Cable
- 13 and 19 . . . Supervisory Preference Contacts
- 14 "CARRIER STOP" return
- 15 Battery positive through carrier start contacts
- 16 . . . Battery positive for alarm cutoff (used with communication)
- 17 Neg. DC

Internal

Necessary internal connections are generally made at the factory, to customer order, before apparatus shipment. For reference purposes, these are outlined in the tabulation below. Check the proper bleeder resistors before applying voltage to the equipment.

Various combinations of the inductors and capacitors of the transmitter output filter are required depending on the channel frequency. These are tabulated in Fig. 9.

Adjustments

This apparatus is generally tuned to and tested at the specified channel frequency before shipment. Final adjustments must be made in the field and are described in the following paragraphs. Fig. 6 shows the locations of the various controls.

OPERATION	BLEEDER RESISTORS IN THE CIRCUIT
48- Volt K-DAR, HZM, and GCY Relaying, Telemetering, and Supervisory	R-47 and R-48
125-Volt K-DAR and GCY Relaying	R-45, R-47 and R-48
125-Volt HZM Relaying, Telemetering, and Supervisory	R-41, R-45, R-47 and R-48
250-Volt K-DAR and GCY Relaying	R-45, R-47 and R-48
250-Volt HZM Relaying, Telemetering, and Supervisory	R-39, R-40, R-41, R-45, R-47 and R-48

⊗ Transmitter

1. Disconnect the coaxial cable and replace with a 50, 60, or 70 ohm non-inductive resistor depending on the characteristic impedance of the cable used.

2. Fig. 9 shows typical output filter connections for various frequency ranges. In some cases it may be necessary to use either a higher or lower range to tune the filter to resonance.

3. Insert fuses F-1 and F-2 to apply power to the apparatus.

4. Connect an A-C Vacuum Tube Voltmeter (VTVM) across the non-inductive load.

5. Unblock the transmitter by closing the CARRIER TEST SWITCH. An alternative is to jumper battery positive to terminal 15.

6. Beginning with the output control R-42 at the maximum counterclockwise position, advance it clockwise until a reading appears on the VTVM. Tune capacitor C-19 for a maximum voltmeter reading.

7. While increasing R-42, tune the output filter for maximum output until the output across the resistor is approximately 8 volts. (Approximately 5.5 volts when operating from 48-volt station battery.)

8. Open the test switch and reconnect the coaxial cable.

Receiver

1. The oscillator output control R-4 is pre-set at the factory. However, should any of the oscillator components be changed (including the transistors and the crystal) R-4 will require adjustment.

a. Connect an A-C VTVM to jacks J-3 and J-4.

b. Adjust R-4 for a 0.3 volt reading on the meter.

2. The unit is shipped to have a gain of approximately 250 millivolts (to produce 10 ma relay current) with input control R-1 in maximum clockwise position. About 10-db additional gain or 80 millivolt sensitivity can be obtained by clipping out resistor R-74, which is connected to the base of Q-4 and the Pos supply for the IF. A further 10-db gain or additional 25 millivolt sensitivity can be obtained by also clipping out resistor R-73, which is connected to the base of Q-5 and the Pos. supply for the IF. Resistors R-71 and R-72 have been selected at the factory to provide an overall gain of approximately 25 millivolts with R-73 and R-74 removed.

a. Sensitivity Adjustment for Noise

If the maximum on-frequency noise level is known or can be measured, the receiver can be adjusted for this level. Disconnect the coaxial cable and connect a 60-ohm non-inductive resistor and a VTVM across terminals 11 and 12. Energize the transmitter and output control R-42 for the same output as the maximum noise. Then adjust the receiver input control R-1 to obtain 1-ma output current. If it is impossible to obtain 1-ma output current with control R-1 in the maximum clockwise position, then clip out resistor R-74, which is connected to the base of Q-4. If the gain is still insufficient, clip out resistor R-73, which is connected to the base of Q-5. After completing the adjustment of R-1, restore the transmitter to full output.

b. Sensitivity Adjustment for Remote Signal

When the maximum on-frequency noise is unknown and cannot be conveniently measured, the receiver may be adjusted for the remote signal. First determine the channel attenuation using a Sierra voltmeter or some other convenient method. Disconnect the coaxial cable and connect a 60-ohm non-inductive resistor and a VTVM across terminals 11 and 12. Add 15-db to the channel attenuation. This compensates for average variations such as channel and voltage variations. For example, if the channel attenuation is 5-db, add this to the 15-db making a total of 20-db. Taking this from 8 volts output of the transmitter, the receiver should then be set for a sensitivity of 0.8 volts. To do this, adjust the transmitter output control R-42 for 0.8 volts and then adjust the receiver input control so as to obtain 10-ma output current. If it is impossible to obtain 10-ma output current with control R-1 in the maximum clockwise position, clip out resistor R-74, which is connected to the base of Q-4. If the gain is still insufficient, clip out resistor R-73, which is connected to the base of Q-5. After completing the adjustment of R-1, restore the transmitter to full output.

It must be kept in mind that the two preceding adjustment procedures are to be used as a guide and will cover the majority of cases; however, cases may arise where conditions change. For example, if the adjustment is made per part a., the noise may increase due to various reasons such as bad insulators, which would require adjusting the receiver to be less sensitive. In the adjustment of part b., the attenuation may increase due to sleet or line switching,

which would necessitate increasing the sensitivity of the receiver.

Reserve Signal Detector

Due to different types of operation and supply voltages, it is not practical to have a calibrated dial for this unit. However, calibration may be made at installation by recording transmitter output (either in db or volts) at various knob settings of the detector unit. Then, by adjusting the knob so as to obtain 10 milliamperes relay current at a remote receiver, any increase or decrease in line attenuation may be noted as the difference between the original setting, and the setting required to obtain the given 10 milliamperes.

250-Volt Resistor Unit

With the apparatus energized, adjust R-4 in the 250-volt resistor unit so as to obtain 125-volts at terminals 17 (neg.) and 19 (pos.) on the relaying set.

Frequency Change

If the frequency is changed in the field, it is necessary to change the input filter FL-1 to the desired channel frequency. This filter is of the plug-in type and may be removed by unsnapping the clamp and pulling the filter out. The transmitter oscillator crystal Y-2 must be changed to the desired channel frequency. The receiver oscillator crystal Y-1 must be changed to the desired channel frequency plus 20 kHz. Figure 9 shows the connections for the transmitter output filter. It is necessary to unsolder the existing connections and make the new connections per the chart. After completing the preceding, the tuning procedure as described under Adjustments for transmitter and receiver should then be followed.

Note also that capacitors C2 and C9 in the transmitter and receiver crystal oscillator circuits, respectively, may have to be changed. For frequencies below 110 kHz, these capacitors are 270 mmf. each. For frequencies of 110 kHz and above, the capacitors are 140 mmf. each.

CAUTION Turn power OFF before removing filters or transistors, as high transient currents may cause permanent damage to the transistors.

MAINTENANCE

Voltage values should be recorded after adjustment in order to establish reference values which will be useful when checking the apparatus. The readings

will remain fairly constant over an indefinite period unless a failure occurs. However, if transistors are changed, there may be considerable difference in these readings without the overall performance being affected.

Typical voltage and current values are given as follows. Voltages should be measured with VTVM. Readings may vary as much as $\pm 20\%$.

In the following paragraphs, the transmitter may be unblocked (transmitting) by closing the CARRIER START circuit in the case of HZM relaying, and by opening the CARRIER START circuit in the case of K-DAR and GCY relaying.

1. For D-C pin jack measurements with reference to neg. d.c., refer to Table 1.
2. For transistor D-C measurements with reference to neg. d.c., refer to Table 2.
3. For D-C bleeder measurements with reference to neg. d.c., refer to Table 3.
4. For typical RF signal measurements for receiver, refer to Table 4.
5. For typical RF signal measurements for transmitter, refer to Table 5.

6. Removal of Printed Circuit Board from Flexitest Case.

To remove the printed circuit board, unplug J-15 and J-16 located near the output filter. Loosen the two screws inside the case near the top. Loosen the slotted thumb screws at the lower end of the board and pull these screws out as far as they will extend. Also remove the receiver coaxial cable plug.

Pull board down so as to disengage the terminals, and lift out.

7. Removal of the Output Filter

After the printed board has been removed, remove the screws on the outside of the case at the bottom. Lift out filter and disconnect the coaxial cable.

8. Receiver Filters

Fig. 13 shows typical receiver selectivity curves both RF and IF. If the filters are checked in a test

setup, it is necessary to use an accurate signal generator or preferably a signal generator and a frequency counter.

9. Minimum Test Equipment for Installation

- a. Milliammeter 0-25 ma DC.
- b. 60-ohm 5-watt non-inductive resistor.
- c. A-C Vacuum Tube Voltmeter (VTVM). Voltage range 0.003 to 30 volts, frequency range 60 Hz to 230-kHz, input impedance 7.5 megohms.

d. D-C Vacuum Tube Voltmeter (VTVM)

Voltage Range: 0.15 to 300 volts
Input Impedance: 7.5 megohms

10. Desirable Test Equipment for Apparatus Maintenance

- a. All items listed in Sections 8 and 9.
- b. Signal Generator

Output Voltage: up to 8 volts
Frequency Range: 20-kHz. to 230-kHz.

- c. Oscilloscope
- d. Ohmmeter
- e. Capacitor checker
- f. Test harness (See Fig. 15)

APPLICATION

1. Receiver Selectivity (Fig. 12)

This shows a typical curve of the overall selectivity of the receiver under steady state conditions.

2. Transmitter Output Selectivity (Fig. 10)

Typical curves are shown so that approximate bandwidths for keying purposes can be determined for any carrier frequency between 30-kHz and 200-kHz.

3. Minimum Channel Spacing (Fig. 14)

This is a graph from which minimum channel spacing can be obtained provided the signal strength of the interfering transmitter and the sensitivity setting of the receiver are known. These can be obtained from calculations or by measurements.

For example, if the interfering transmitter voltage is measured (at the receiver) and found to be 2.5 volts, this would be 10-db down from 8 volts. This point can be located on the right hand column of the graph. Then, if the receiver sensitivity were set to operate on 0.8 volts or 20-db, this point would be located on the left hand column. A line could then be drawn through the two points as shown by the dotted line. The intersection of this line with the center line indicates the minimum channel spacing. In this case if the interfering signal is being keyed on-off, at 15 pps, the minimum spacing would be 2.5-kHz.

4. Supervisory Control Connections (Fig. 7)

When supervisory control is used with relaying, the supervisory control relay coil is connected in series with the RRH coil in place of the alarm relay. When supervisory control is used alone, a 1200-ohm resistor R3 is connected in series with the control relay coil by removing the jumper across R3, as shown in Fig. 7. In order to maintain proper mark space ratio, the relay bias current is adjusted for 9 milliamperes as indicated.

The receiver RF filter and the IF filter limits are shown on Fig. 15. Both filters are of the plug-in type and the test circuits with pin connections are shown at the top of each curve. The IF filter is divided into two separate sections. The selectivity shown is for each section, and the pin connections for each section are also shown in the test circuit sketch.

TABLE 1

D-C PIN JACK MEASUREMENTS WITH REFERENCE TO NEG. DC ⊕

Description	Jack	CONDITION A Tx-Blocked †† Rx-No Signal		CONDITION B Tx-Blocked Rx-With Signal		CONDITION C Tx-Unblocked Rx-No Signal	
		129 VDC	51 VDC	129 VDC	51 VDC	129 VDC	51 VDC
RF Input	J-2	0	0	0.3 V	0.3 V		
DC Q-1 Base	J-3	20 V	20 V	20 V	20 V		
DC R _x B+	J-4	20 V	20 V	20 V	20 V		
DC R _x Osc	J-5	7 V	7 V	7 V	7 V		
DC Q-5 Base	J-6	20 V	20 V	20 V	20 V		
B-	J-7						
DC-P1-E	J-8	110 V	32 V	110 V	32 V	110 V	32 V
DC-Q-7 Base	J-9	69 V	0 V	78 V	2.3 V	66 V	0.3 V
DC Q-7 Emit	J-10	70 V	1.0 V	78 V	1.4 V	66 V	1.0 V
DC T _x Osc	J-11	7 V	7 V	7 V	7 V	7 V	7 V
B+	J-12	129 V	51 V	129 V	51 V	129 V	51 V
DC Q-10 Base	J-13					18 V	18 V
DC Q-10 Emit	J-14					18 V	18 V
RF ma out	J-15					130 ma	130 ma
DC ma RRH and ALARM				18 ma	18 ma		

†† Tx = transmitter, Rx = receiver

TABLE 2
TYPICAL TRANSISTOR DC MEASUREMENTS WITH REFERENCE TO NEG. DC ⊕

Transistor	Condition A Tx-Blocked Rx-No Signal (Volts)			Condition B Tx-Blocked Rx-With Signal (Volts)			Condition C Tx-Unblocked Rx-No Signal (Volts)		
	E†	B†	C†	E†	B†	C†	E†	B†	C†
Q-1	20.0	20.0	0.38	20.0	20.0	0.4			
Q-2	7	7.2	1.8	7	7.2	1.8			
Q-3	6.2	8.0	2	6.2	8	2.0			
Q-4	20.0	20.0	2.6	20.0	20.0	2.8			
Q-5	20.0	20.0	2.6	20.0	20.0	2.8			
Q-6									
129 VDC	110	110	129	115	114	129			
51 VDC	32	32	51	32	32	51			
Q-7									
129 VDC	70	68	129	78	80	86			
51 VDC	1.0	0	51	1.4	2.2	7.0			
Q-8	6.2	8	2	6.2	8	2	6.2	8	2
Q-9	7	7.2	1.8	7	7.2	1.8	7	7.2	1.8
Q-10††							18	18	0.4
Q-12††							0.27	0.20	50
Q-15††							0.27	0.20	50

† E-Emitter; B-Base; C-Collector.

†† With respect to term F on printed board.

TABLE 3

D-C BLEEDER MEASUREMENTS WITH REFERENCE TO NEG. DC

Measurement	129 VDC			51 VDC		
	A†	B†	C†	A†	B†	C†
Junction R-61 and R-62 (J-8)	110V	110V	110V	32V	32V	32V
Junction R-61 and R-27 (J-10)	70V	78V	66V	1.0V	1.4V	1.0V
Junction R-27 and R-60 (P1-P)	69V	77V	65V	0	0	0
Junction CR-8 and R-64 (P1-K)	58V	58V	58V	51V	51V	51V
Junction R-48 and R-47 (J-14)	—	—	18V	—	—	18V
Junction R-45 and R-47 (TP-9)	—	—	45V	—	—	51V
Junction R-45 and R-41 (TP-8)	—	—	98V	—	—	51V

†Conditions: A — Tx-Blocked, Rx-No Signal; B — Tx-Blocked, Rx-With Signal; C — Tx-Unblocked, Rx-No Signal.

TABLE 4
TYPICAL RF SIGNAL MEASUREMENTS FOR RECEIVER
(Made with 0.1 Volt at Terminal 5 of FL1)

Check Point	25 MV Sensitivity (Volts)	80 MV Sensitivity (Volts)	250 MV Sensitivity (Volts)
With Receiver Crystal Out			
FL1-5 to Gnd.	0.1	0.1	0.1
T1-1 to Gnd.	0.1	0.1	0.1
Q1-E to Gnd.	0.05	0.05	0.05
Q1-C to Gnd.	0.07	0.07	0.07
T3-1 to Gnd.	0.07	0.07	0.07
Q4-C to Gnd.	0.07	0.07	0.07
With Receiver Crystal In			
Q4-C to Gnd.	0.5	0.5	0.25
J6 to Gnd.	0.15	0.1	0.08
Q5-C to Gnd.	7.0	1.7	0.8
Q6-B to Gnd.	2.0	0.5	0.4
Q6-C to Gnd.	13.0	10.0	8.0
T4-1 to Gnd.	13.0	10.0	8.0
T4-3 to T4-4	4.5	3.5	2.5
J9 to J10 (DC)	0.74	0.75	0.65

TABLE 5

TYPICAL RF SIGNAL MEASUREMENTS FOR TRANSMITTER	
CHECK POINT	VOLTS
T5-1 to Gnd.	5.5
T5-3 to Gnd.	1.0
J13 to Gnd.	0.085
Q10-C to Gnd.	6.0
T6-2 to Gnd.	6.0
Q12-B to Gnd.	0.8
Q15-B to Gnd.	0.8
Q12-C to Gnd.	38.0
Q15-C to Gnd.	38.0
T7-5 to Gnd.	9.8
Output to Gnd.	8.0

ELECTRICAL PARTS LIST

CIRCUIT SYMBOL	FUNCTION	DESCRIPTION	MANUFACTURER'S DESIGNATION
		<u>CAPACITORS</u>	
C-1	Rcvr. Bleeder	2.0 μ f, $\pm 20\%$, 200 VDC, Paper	330C567 H11
†C-2	Rcvr. Osc. Feedback	140/270 μ f, $\pm 20\%$, 500 VDC, Mica	330C566H43 or 330C566H57
C-3	Rcvr. Osc. Bleeder Bypass	0.02 μ f, MRC, 600 VDC, Disc	330C569 H47
C-5	Q-6 Emitter Bypass	1.0 μ f, $\pm 20\%$, 200 VDC Paper	330C567 H09
C-6	Rcvr. Rectifier Bypass	Same as C-5	
✱ C-7	B- to B+ Bypass	2 μ f, $\pm 5\%$, 330 VAC, Paper	14C9400 H13
✱ C-8	B- to GND	1.0 μ f, $\pm 10\%$, 330 VAC, Paper	1876999
†C-9	Xmtr. Osc. Feedback	Same as C-2	
C-10	Xmtr. Osc.	Same as C-3	
C-11	Key Filter	0.1 μ f, $\pm 20\%$, 200 VDC, Paper	330C567 H02
C-12	Q-10 Emitter Bypass	0.25 μ f, $\pm 20\%$, 200 VDC, Paper	330C567 H05
C-13	Q-10 Bleeder Bypass	Same as C-12	
C-14	PA Base Bypass	Same as C-12	

† Note: 140 μ f for osc. freq. 110-kHz and above.
270 μ f for osc. freq. below 110-kHz.

CIRCUIT SYMBOL	FUNCTION	DESCRIPTION	MANUFACTURER'S DESIGNATION
CAPACITORS (Concluded)			
C-18	PA Bleeder	0.5 μf , $\pm 20\%$, Paper	330C567 H06
C-19	Output Filter Tuning	500 μf , Variable, Air	328C092 H01
C-20	Output Filter	390 μf , $\pm 5\%$, 2500 VDC, Mica	330C561 H15
C-21	Output Filter	680 μf , $\pm 5\%$, 2500 VDC, Mica	330C561 H21
C-22	Output Filter	1200 μf , $\pm 5\%$, 2500 VDC, Mica	330C561 H27
C-24	FL-2 Decoupling	Same as C-12	
C-25	Q-7 Emitter	12 mfd, $\pm 20\%$, 200 VDC	187A177 H01
C-26	Q-7 Base Bypass	.01 mfd, $\pm 10\%$, 100 VDC	76.3A219 H15
D I O D E S			
CR-1	Bridge Rectifier	General Purpose, 1N63	584C433 H02
CR-2	Bridge Rectifier	Same as CR-1	
CR-3	Bridge Rectifier	Same as CR-1	
CR-4	Bridge Rectifier	Same as CR-1	
CR-5	Q-10 Collector	Same as CR-1	
CR-6	Q-7 Base-Emitter	Type 1N457A	184A855 H07
CR-7	Voltage Regulator	Type 1N3686	185A212 H06
CR-8	Voltage Regulator	Type 1N1369	584C434 H05
CR-9	Q-7 Collector	Type 1N3811	185A089 H08
CR-10	Q-10 Emitter	Type 1N3028A	188A302 H14
CR-11	Voltage Regulator	Type 1N3024B	188A302 H12

ELECTRICAL PARTS LIST

CIRCUIT SYMBOL	FUNCTION	DESCRIPTION	MANUFACTURER'S DESIGNATION
<u>FUSE HOLDERS</u>			
FH-1	B-	For Type 3AGC Fuses	584C271 H02
FH-2	B+	Same as FH-1	
<u>FUSES</u>			
F-1	B-	3AGC 3/4 amp.	S#330C691 H12
F-2	B+	Same as F-1	
<u>FILTERS</u>			
FL-1 or FL-201	Rcvr. RF Bandpass	30 to 200 kHz Freq. to be specified by customer	
FL-2	Rcvr. 1F Bandpass	20-kHz Fixed Freq.	541D086G01
FL-3	Transmitter Output	30-200 kHz	407C772G01
<u>CONNECTORS</u>			
J-1	Printed Circuit	Printed Circuit Female Plug	54-B-7125 H03
J-2	RF Input	UG-185-U	584C292 H07
J-3	Rcvr. Osc. Output	Terminal Studs	330C592 H01
J-4	Rcvr. Mixer-Amp Supply	Same as J-3	
J-5	Rcvr. Osc. Supply	Same as J-3	
J-6	Q-5 Base	Same as J-3	
J-7	B-	Same as J-3	
J-8	Q-6 Supply	Same as J-3	

ELECTRICAL PARTS LIST

CIRCUIT SYMBOL	FUNCTION	DESCRIPTION	MANUFACTURER'S DESIGNATION
<u>CONNECTORS (Concluded)</u>			
J-9	Q-7 Base	Same as J-3	
J-10	Q-7 Emitter	Same as J-3	
J-11	Xmtr. Osc. Supply	Same as J-3	
J-12	B+	Same as J-3	
J-13	Xmtr. Osc. Output	Same as J-3	
J-14	Q-10 Supply	Same as J-3	
J-15	Output Filter	Banana Tip Red	328C093 H01
J-16	Output Filter GND	Banana Tip Black	328C093 H02
P-1	Printed Circuit	Printed Circuit Male Plug	54-B-7126 H03
<u>INDUCTORS</u>			
L-1	Core and Coil Assembly	11 MH Total – 6 MH Tap (Part of FL-3)	329C450
L-2	Core and Coil Assembly	2.5 MH (Part of FL-3)	329C449
L-3	RF Choke	1.0 MH, 300 ma	R-300
L-4	RF Choke	Same as L-3	
<u>TRANSISTORS</u>			
Q-1	Rcvr. Mixer	Type 2N525	184A638H13
Q-2	Rcvr. Csc.	Type 2N414	184A638H14

ELECTRICAL PARTS LIST

CIRCUIT SYMBOL	FUNCTION	DESCRIPTION	MANUFACTURER'S DESIGNATION
<u>TRANSISTORS (Concluded)</u>			
Q-3	Rcvr. Osc.	Same as Q-2	
Q-4	Rcvr. IF	Same as Q-1	
Q-5	Rcvr. IF	Same as Q-1	
Q-6	Rcvr. IF	Type 2N657	184A638H15
Q-7	Rcvr. Output	Type 2N698	762A585H02
Q-8	Xmtr. Osc.	Same as Q-2	
Q-9	Xmtr. Osc.	Same as Q-2	
Q-10	Xmtr. Amp.	Same as Q-1	
Q-12	Xmtr. PA	Type 2N657	184A638H15
Q-15	Xmtr. PA	Same as Q-12	
<u>RESISTORS</u>			
R-1	Rec. Input	25 K, $\pm 20\%$, 1/4 W, Pot.	584C276 H23
R-2	Filter Matching	10 K, $\pm 10\%$, 1/2 W	330C595 H37
R-3	Filter Load	Same as R-2	
R-4	Rcvr. Osc.	1 K, $\pm 20\%$, 1/4 W, Pot.	584C276 H19
R-5	Rcvr. Voltage Divider	6.2 K, $\pm 5\%$, 1 W	330C666 H68
R-6	Q-2 Collector	1.2 K, $\pm 5\%$, 1/2 W	330C664 H51
R-8	Rcvr. Voltage Divider	15K $\pm 1\%$, 3W	763A126H08
R-9	Rcvr. Voltage ♦ Divider	Same as R-8	

ELECTRICAL PARTS LIST

CIRCUIT SYMBOL	FUNCTION	DESCRIPTION	MANUFACTURER'S DESIGNATION
		<u>RESISTORS (Continued)</u>	
R-10	Q-2 Base	Same as R-2	
R-11	Q-2 Base	100 K, $\pm 5\%$, 1/2 W	330C665 H05
R-12	Q-3 Collector	Same as R-6	
R-13	Q-3 Emitter	390 Ohms, $\pm 5\%$, 1/2 W	330C664 H39
R-14	Q-3 Base	Same as R-2	
R-15	Q-3 Base	Same as R-11	
R-16	Rcvr. Osc. Bleeder	2.2 K, $\pm 10\%$, 1/2 W	330C595 H41
R-17	Rcvr. Osc. Bleeder	18 K, $\pm 10\%$, 2 W	330C597 H40
R-18	Rcvr. Osc.	9.1 K, $\pm 5\%$, 1/2 W	330C664 H72
R-19	Q-4 Bias	100 Ohms, $\pm 5\%$, 1/2 W	330C664 H25
R-20	Q-4 Bias	Same as R-2	
R-21	Q-5 Bias	150 Ohms, $\pm 5\%$, 1/2W	330C664 H29
R-22	Q-5 Bias	Same as R-2	
R-23	Q-6 Bias	330 Ohms, $\pm 5\%$, 1/2 W	330C664 H37
R-24	Q-6 Bias	Same as R-2	
R-25	Q-6 Emitter	Same as R-19	
R-26	Q-7 Base	Same as R-6	
R-27	Q-7 Bias	20 Ohms, $\pm 5\%$, 1/2 W	330C664 H08
R-28	Xmtr. Osc. Bleeder	Same as R-18	
R-29	Xmtr. Osc. Bleeder	Same as R-17	
R-30	Xmtr. Osc. Bleeder	Same as R-16	

ELECTRICAL PARTS LIST

CIRCUIT SYMBOL	FUNCTION	DESCRIPTION	MANUFACTURER'S DESIGNATION
		<u>RESISTORS (Continued)</u>	
R-31	Q-8 Base	Same as R-11	
R-32	Q-8 Base	Same as R-2	
R-33	Q-8 Emitter	Same as R-13	
R-34	Q-8 Collector	Same as R-6	
R-35	Q-9 Base	Same as R-11	
R-36	Q-9 Base	Same as R-2	
R-37	Q-9 Collector	Same as R-6	
R-38	Key Filter	Same as R-23	
R-39	Buffer Voltage Divider	36 K, $\pm 5\%$, 2 W	330C668 H86
R-40	Buffer Voltage Divider	Same as R-39	
R-41	Buffer Voltage Divider	Same as R-2	
R-42	Xmtr. Osc. Output	Same as R-4	
R-43	Q-10 Bias	Same as R-23	
R-44	Q-10 Bias	33 K, $\pm 5\%$, 1/2 W	330C664 H85
R-45	Buffer Voltage Divider	15 K, $\pm 10\%$, 1 W	330C596 H39
R-47	Buffer Voltage Divider	6.8 K, $\pm 5\%$, 1/2 W	330C664 H69
R-48	Buffer Voltage Divider	15 K, $\pm 5\%$, 1/2 W	330C664 H77
R-49	PA Bias	27 K, $\pm 5\%$, 2 W	330C668 H83

ELECTRICAL PARTS LIST

CIRCUIT SYMBOL	FUNCTION	DESCRIPTION	MANUFACTURER'S DESIGNATION
		<u>RESISTORS (Concluded)</u>	
R-50	Xmtr. PA	Same as R-19	
R-52	Q-12 Emitter	10 Ohms, $\pm 5\%$, 1/2 W	330C664 H01
R-55	Q-15 Emitter	Same as R-52	
R-59	Xmtr. Bleeder	47 Ohms, $\pm 10\%$, 1/2 W	330C595 H09
R-60	Recvr. Bleeder	1 K, $\pm 5\%$, 25 W	584C416 H62
R-61	Recvr. Bleeder	600 Ohms, $\pm 5\%$, 25 W	584C416 H57
R-62	Recvr. Bleeder	350 Ohms, $\pm 5\%$, 25 W	584C416 H52
R-64	Xmtr. Bleeder	1200 Ohms, $\pm 5\%$, 25 W	584C416 H64
R-66	T-7 Load	560 Ohms, $\pm 5\%$, 2 W	330C668 H43
R-67	Xmtr. Blocking	10 Ohms, $\pm 5\%$, 2 W	330C668 H01
R-68	Xmtr. Blocking	10 K, $\pm 10\%$, 10 W	330C577 H01
R-69	Q-10 Emitter	Same as R-19	
R-70	FL2 Decoupling	470 Ohms, $\pm 10\%$, 1/2 W	330C595 H21
R-71	Q-4 Emitter	Determined in test	
R-72	Q-5 Emitter	Determined in test	
R-73	Q-5 Base	220 Ohms, $\pm 10\%$, 1/2 W	187A641H11
R-74	Q-4 Base	1K, $\pm 5\%$, 1/2 W	184A763H27
R-75	Q-4 Collector	22 K, $\pm 10\%$, 1/2 W	330C595 H41
R-76	Q-5 Collector	Same as R-75	

ELECTRICAL PARTS LIST

CIRCUIT SYMBOL	FUNCTION	DESCRIPTION	MANUFACTURER'S DESIGNATION
<u>TRANSFORMERS</u>			
T-1	Rcvr. Input	Impedance Ratio 10 K; 10K	714B677G01
T-2	Rcvr. Osc.	Impedance Ratio 10 K: 400 ohms	205C043G01
T-3	Rcvr. Mixer	Impedance Ratio 25 K: 300 ohms	205C043G03
T-4	IF Output	Impedance Ratio 4 K: 500 ohms	S#1962693, L-592289
T-5	Xmtr. Osc.	Same as T-2	
T-6	Xmtr. Buffer	Impedance Ratio 10 K: 400 ohms CT	'265C864G01
T-7	Xmtr. Output	Impedance Ratio 1930: 60	S#1962694, J-633000
<u>TEST POINTS</u>			
TP-1	R-5	Terminal studs	330C592 H02
TP-2	R-8	Same as TP-1	
TP-3	R-17	Same as TP-1	
TP-4	R-18	Same as TP-1	
TP-5	R-28	Same as TP-1	
TP-6	R-39 & R-40	Same as TP-1	
TP-7	R-41	Same as TP-1	
TP-8	R-45	Same as TP-1	
TP-9	R-47	Same as TP-1	

ELECTRICAL PARTS LIST

CIRCUIT SYMBOL	FUNCTION	DESCRIPTION	MANUFACTURER'S DESIGNATION
<u>SOCKETS</u>			
X-1	FL-1	Octal	330C689 H01
X-2	FL-2	Same as X-1	
X-4	Rear Mounted Voice Adaptor	Same as X-1	
XY-1	Rec. Y-1	Crystal	584C606 H01
XY-2	Xmtr. Y-2	Same as XY-1	
<u>CRYSTALS</u>			
Y-1	Rcvr. Osc.	Specify Channel Freq. Plus 20-kHz.	328C083
Y-2	Xmtr. Osc.	Specify Freq. Same as Channel Frequency	328C083
<u>RESERVE SIGNAL DETECTOR</u> (S#470D167G02)			
R-1	Resistor, Level Control	200 K, 2 W, Pot.	184A086H27
R-2	Resistor, Limiting	2000 ohms, 2" tube.	1267296
S-1	Test Switch	SPST Normally Open	327C854 H01

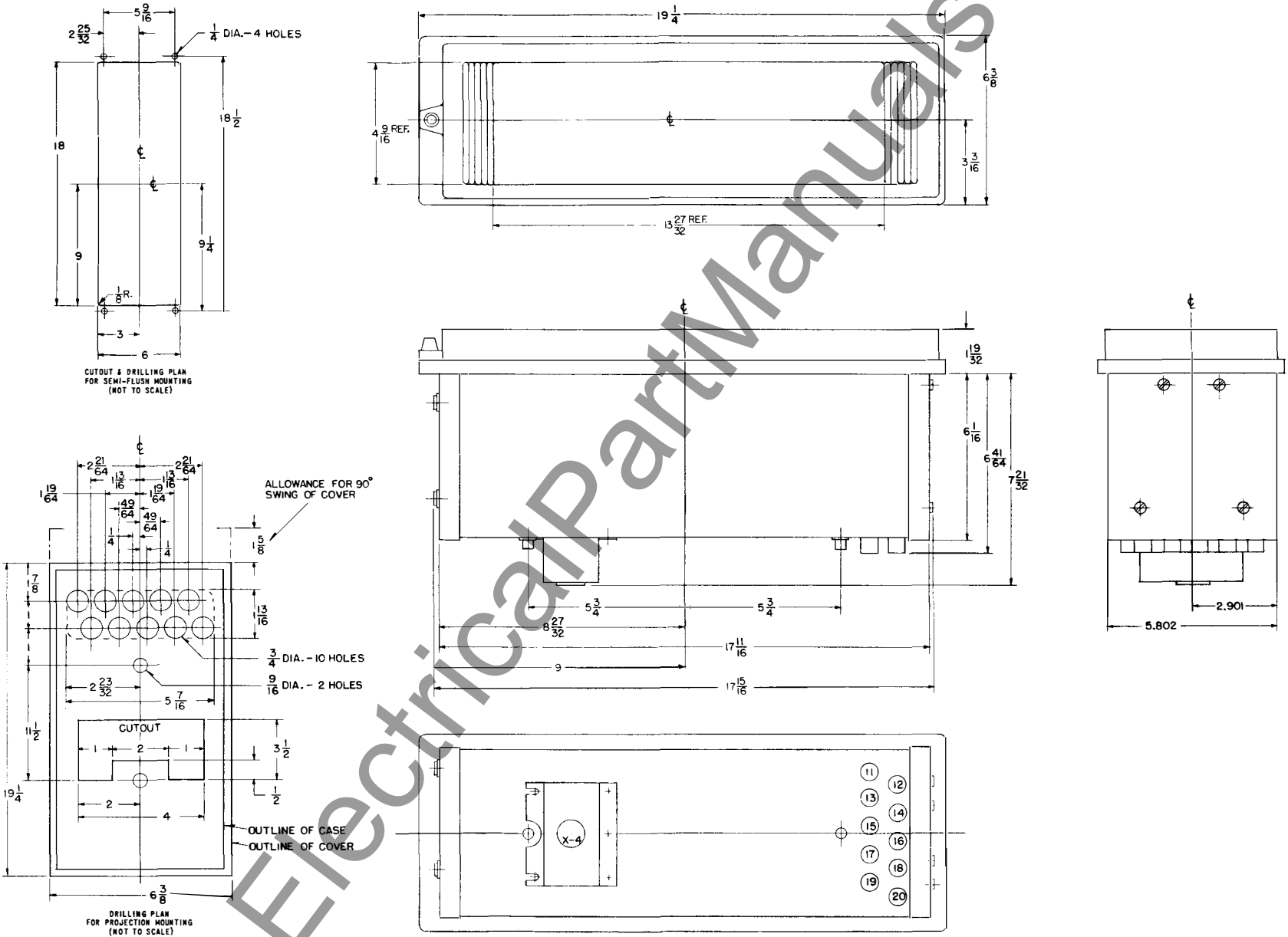
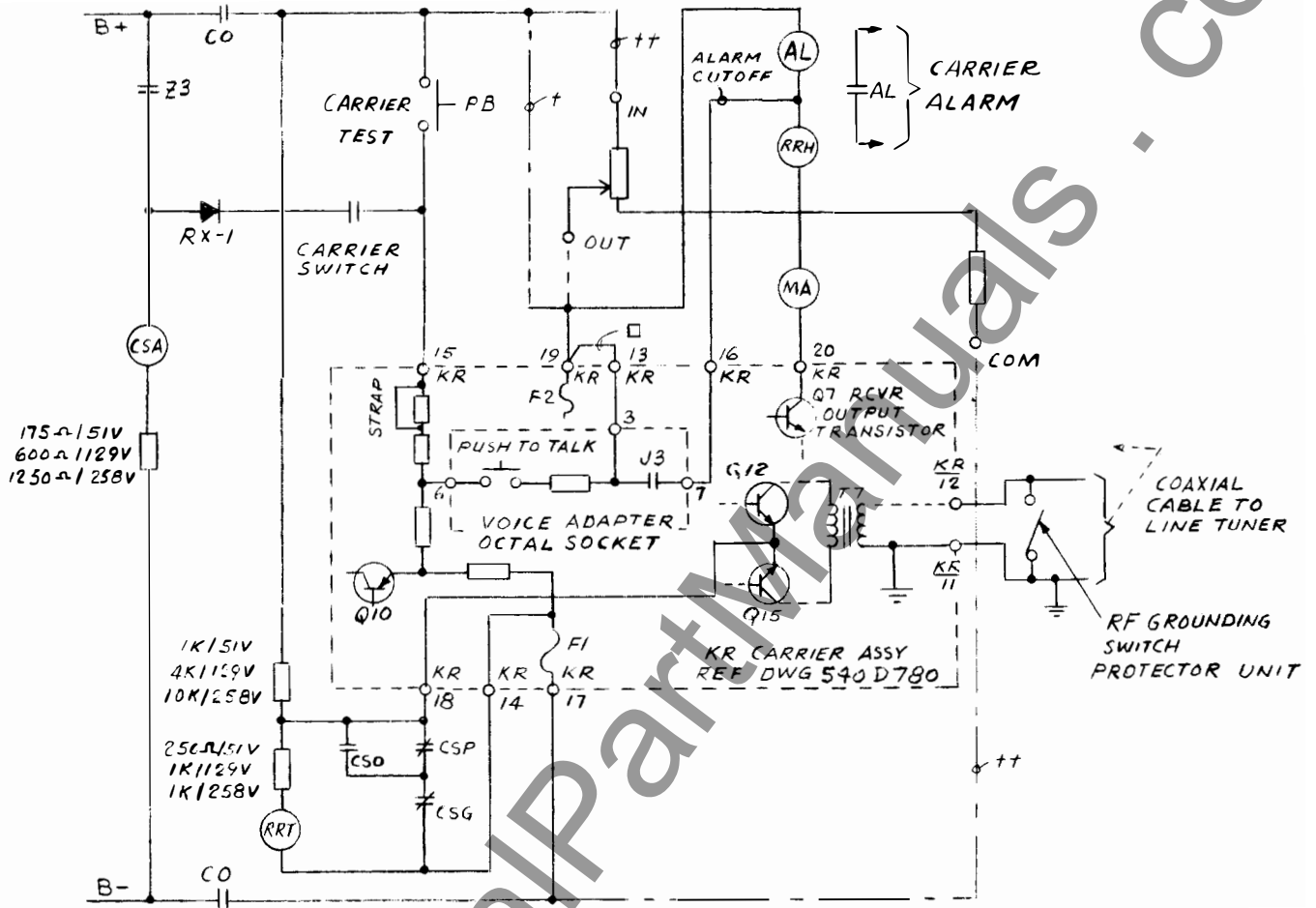

Fig. 1 Outline Drawing, (Flexitest Case) (540D753)

TYPE KR CARRIER SET



REQUIREMENTS FOR HZ/HZM RELAYING

SUPPLY VOLTAGE	CARRIER START	CARRIER STOP	STRAP
5VDC	+5V, 7MA	+28V	IN
129 VDC	+129V, 8MA	+40V	IN
258 VDC	+258V, 8MA	+40V	OUT

KR RELAYING TRANSMITTER /
RECV EXTERNAL CONNECTIONS

TERMINAL - CONNECTION

- 11 GROUND
- 12. COAXIAL CABLE
- 13 SUPERVISORY PREFERENCE CONTACT
- 14. CARRIER STOP B- RETURN
- 15 CARRIER START (POSITIVE)
- 16 ALARM CUTOFF FOR COMMUNICATIONS
- 17 B MINUS
- 18 CARRIER STOP (HZ/HZM)
- 19 B PLUS
- 20 RELAY COIL

NOTES

- △ CONNECT RX-1 (DWG 22B5605 - SW 1595821) AS SHOWN
- + FOR 51 & 129 VDC SUPPLY.
- ++ FOR 258 VDC SUPPLY USE 330C191H01 RESISTOR UNIT REF DWG 223B497
- FOR SUPERVISORY CONTROL PREFERENCE CONTACTS.

Fig. 3- Relaying Control Circuits - HZ/HZM (Dwg. 1-329C704)

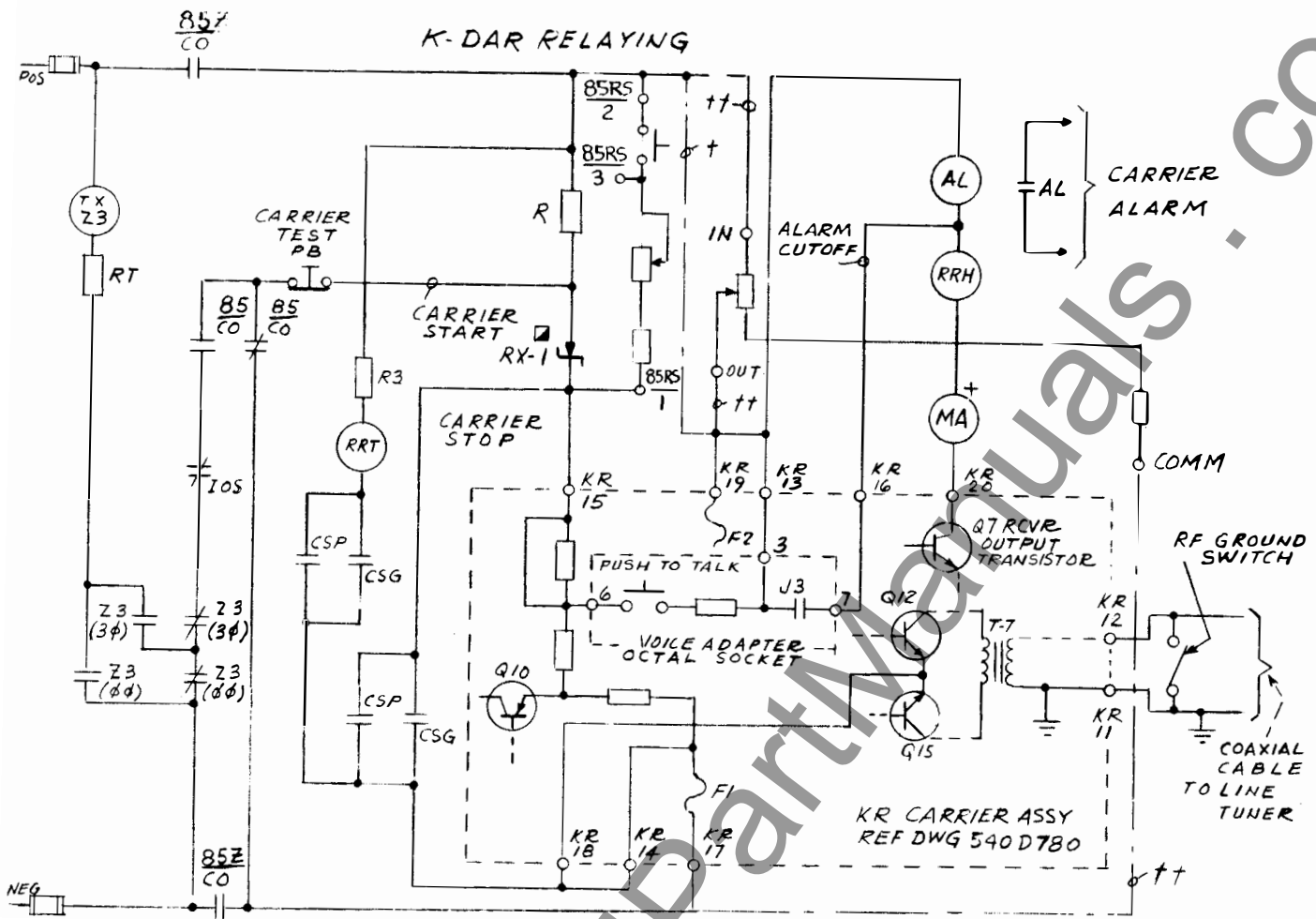

REQUIREMENTS FOR K-DAR RELAYING

SUPPLY VOLTAGE	CARRIER START	CARRIER STOP	R
51 VDC	+ 37V, 7MA	C VOLTS	2K
129 VDC	+100V 8MA	C VOLTS	3.75K
258 VDC	+100V 5 MA	0 VOLTS	19K

KR RELAYING TRANSMITTER /
 RECV. EXTERNAL CONNECTIONS
 TERMINAL CONNECTION

- 11 GROUND
- 12 COAXIAL CABLE
- 13 SUPERVISORY PREFERENCE CONTACT
- 14 CARRIER STOP B- RETURN
- 15 CARRIER START (POSITIVE)
- 16 ALARM CUTOFF FOR COMMUNICATIONS
- 17 B MINUS
- 18 CARRIER STOP (HZ/HZM)
- 19 B PLUS
- 20 RELAY COIL

NOTES

- ~~FOR "R" USE OHMITE VITREOUS ENAMELED DIVIDOHM ADJUSTABLE 4K OR 20K 25W RESISTOR. CONNECT & ADJUST FOR VALUES SHOWN~~
- ~~N KA RELAY~~
- TYPE IN3051 IN CARRIER AUX. RELAY
- + FOR 51 & 129 VDC SUPPLY
- ++ FOR 258VDC SUPPLY USE 330C191H01 RESISTOR UNIT REF DWG 223B497

85RS - RESERVE SIGNAL DETECTOR (WHEN USED)

Fig. 4-Relaying Control Circuits-K-Dar (Dwg. 3-329C704)

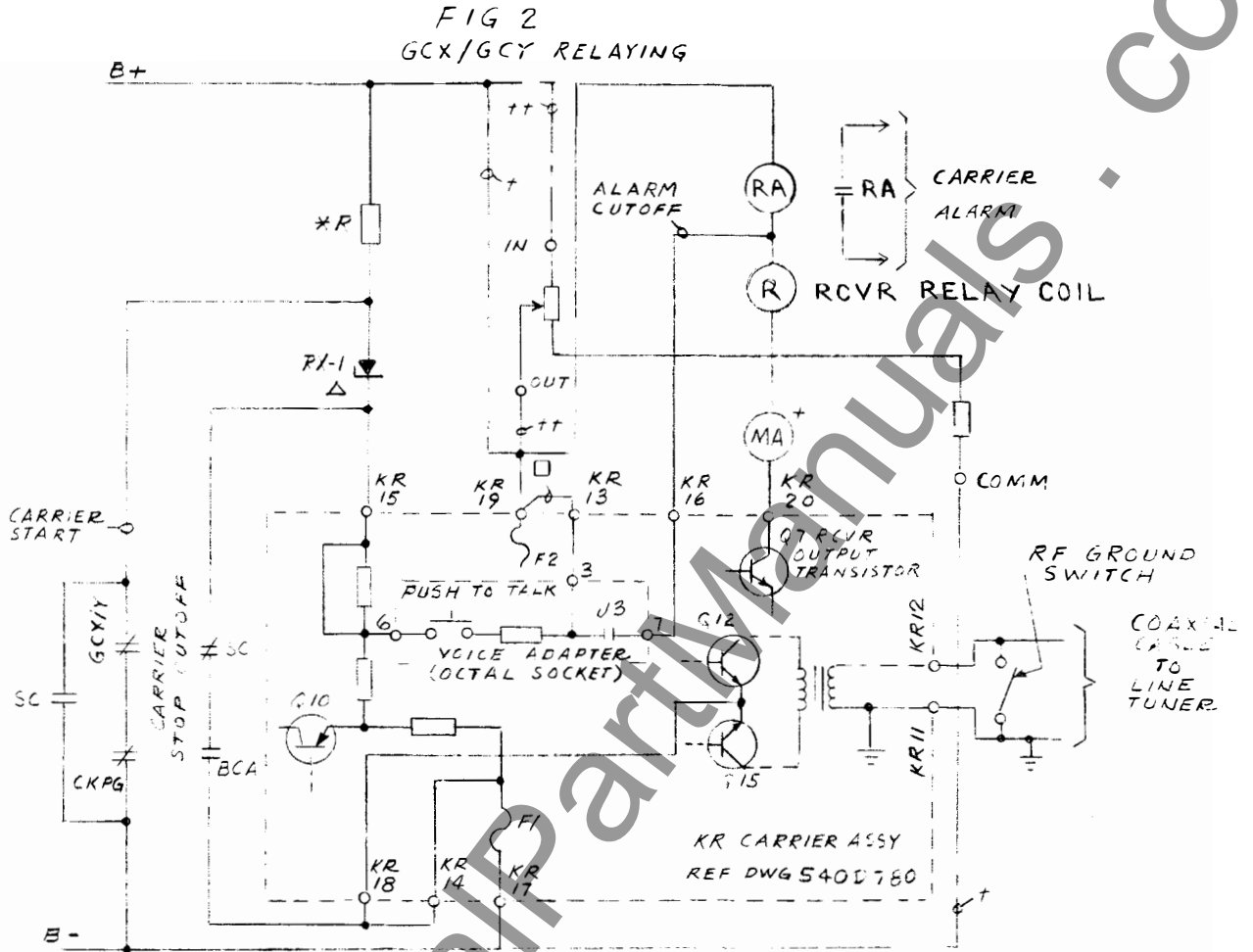

REQUIREMENTS FOR GCX/GCY RELAYING

SUPPLY VOLTAGE	CARRIER START	CARRIER STOP	R
51 VDC	+37V, 7MA	0 VOLTS	2K
129 VDC	+100V 2MA	0 VOLTS	3.75K
258 VDC	+100V 2MA	0 VOLTS	19.K

**KR RELAYING TRANSMITTER /
RECV. EXTERNAL CONNECTIONS
TERMINAL- CONNECTION**

- 11. GROUND
- 12. COAXIAL CABLE
- 13. SUPERVISORY PREFERENCE CONTACT
- 14. CARRIER STOP B- RETURN
- 15. CARRIER START (POSITIVE)
- 16. ALARM CUTOFF FOR COMMUNICATIONS
- 17. B MINUS
- 18. CARRIER STOP (HZ/HZM)
- 19. B PLUS
- 20. RELAY COIL

NOTES

- * FOR 'R' USE OHMITE VITREOUS ENAMELED DIVIDESHM ADJUSTABLE 4K OR 20K 25 W RESISTOR. CONNECT & ADJUST FOR VALUES SHOWN
- Δ - RE IN 20 F1
- 1 FOR 51 & 129 VDC SUPPLY
- ++ FOR 258VDC SUPPLY USE 330C191H01 RESISTOR UNIT REF DWG 223B497
- FOR SUPERVISORY CONTROL PREFERENCE CONTACTS

★ Fig. 5. Relaying Control Circuits—GCX/GCY (Dwg. 2-329C704)

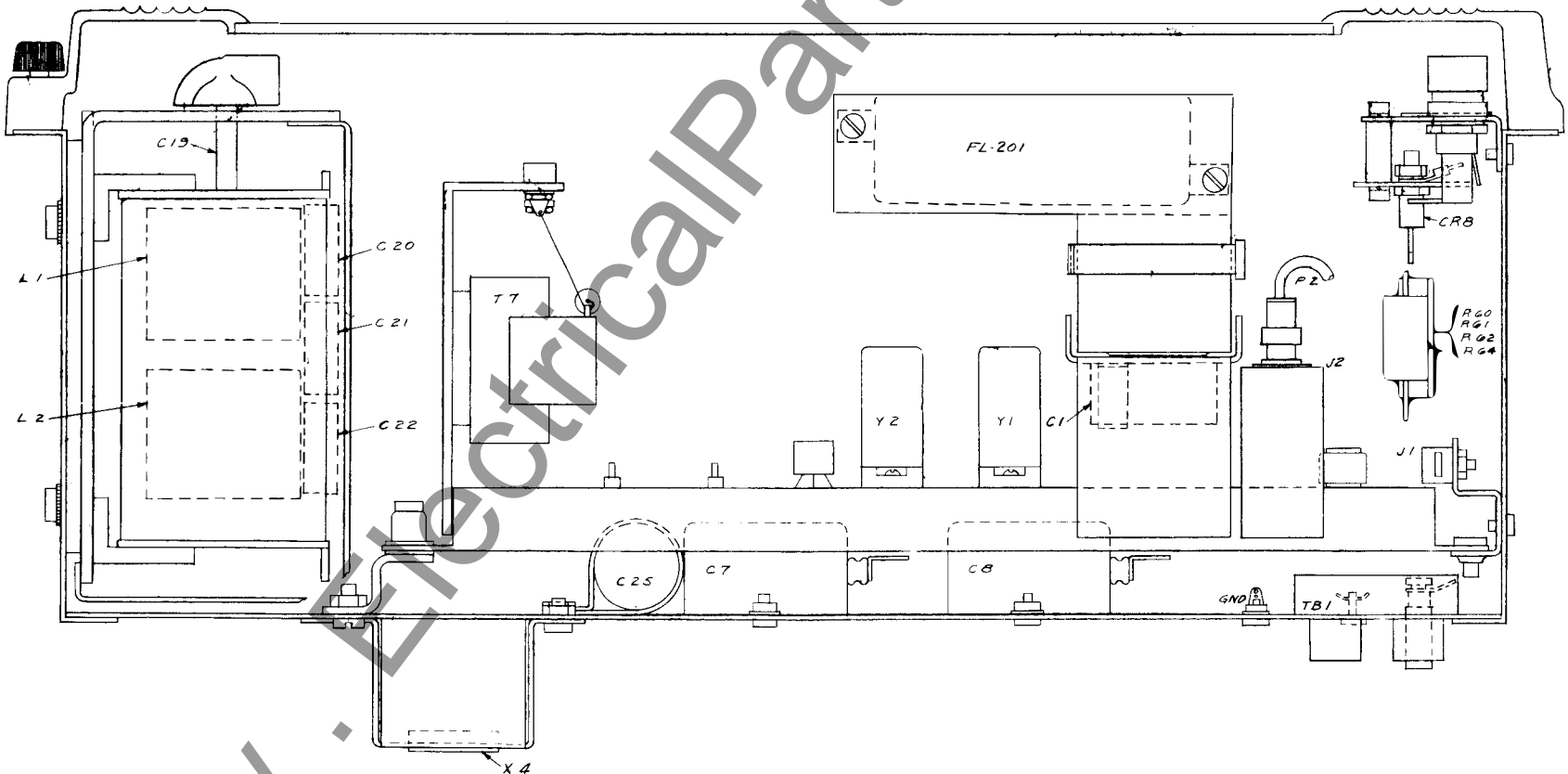
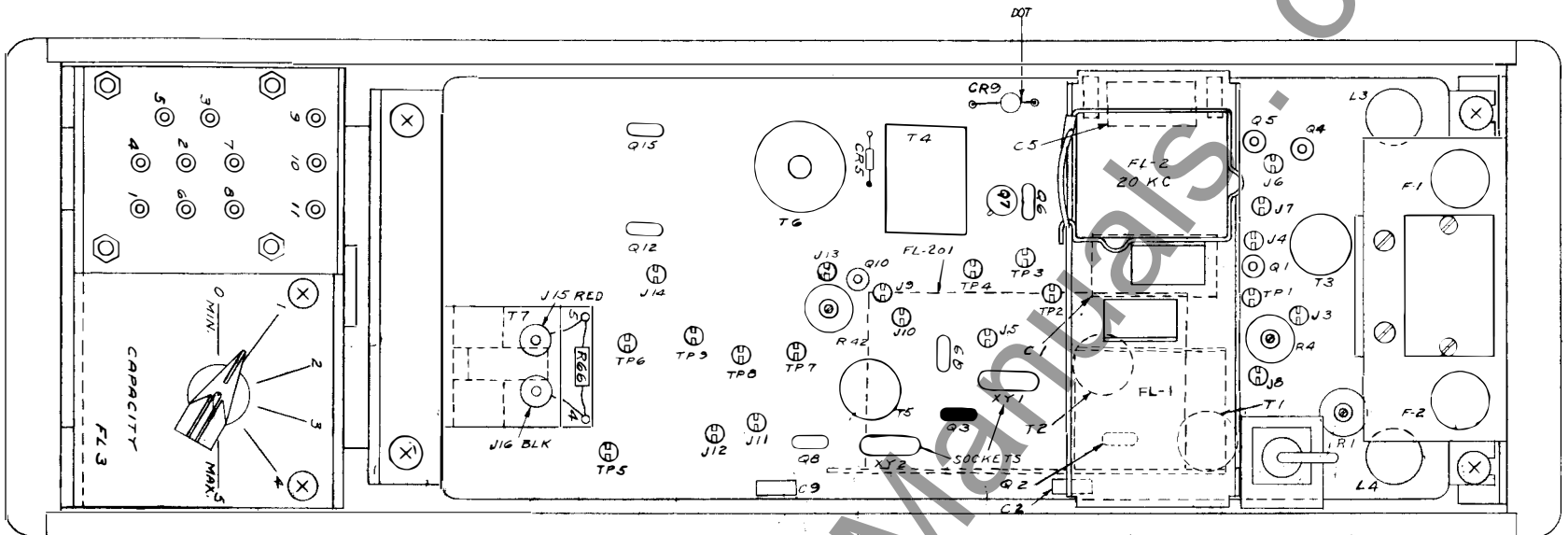
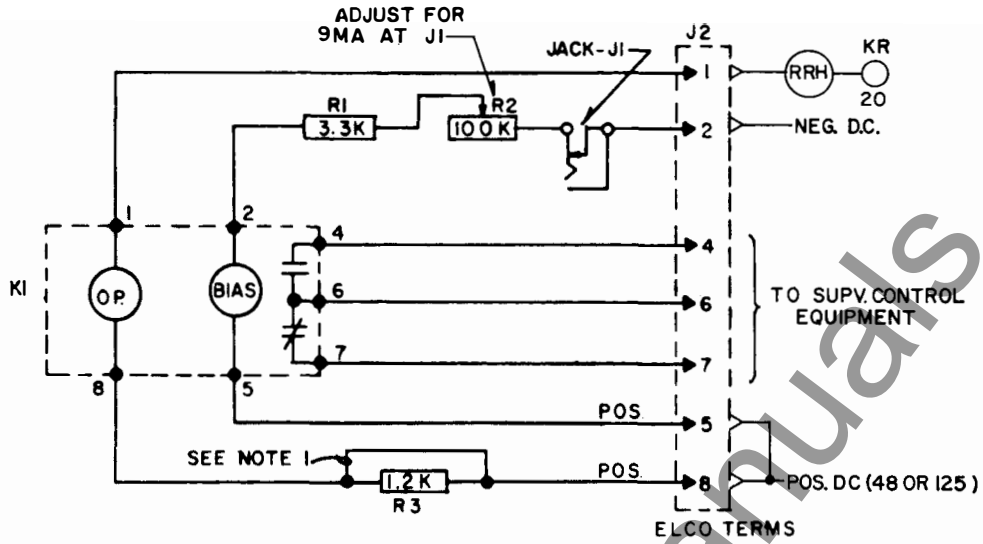

Fig. 6. Component Location (Dwg. 540D781)



NOTES:

1. REMOVE FOR KR CARRIER PLUS SUPV. CONTROL WITHOUT RELAYING.
2. POLARITY SHOWN CLOSES CONTACT BETWEEN TERMINALS 4 & 6.

J 2			
1	2	3	4
5	6	7	8

AS VIEWED FROM REAR OF PANEL

629A552

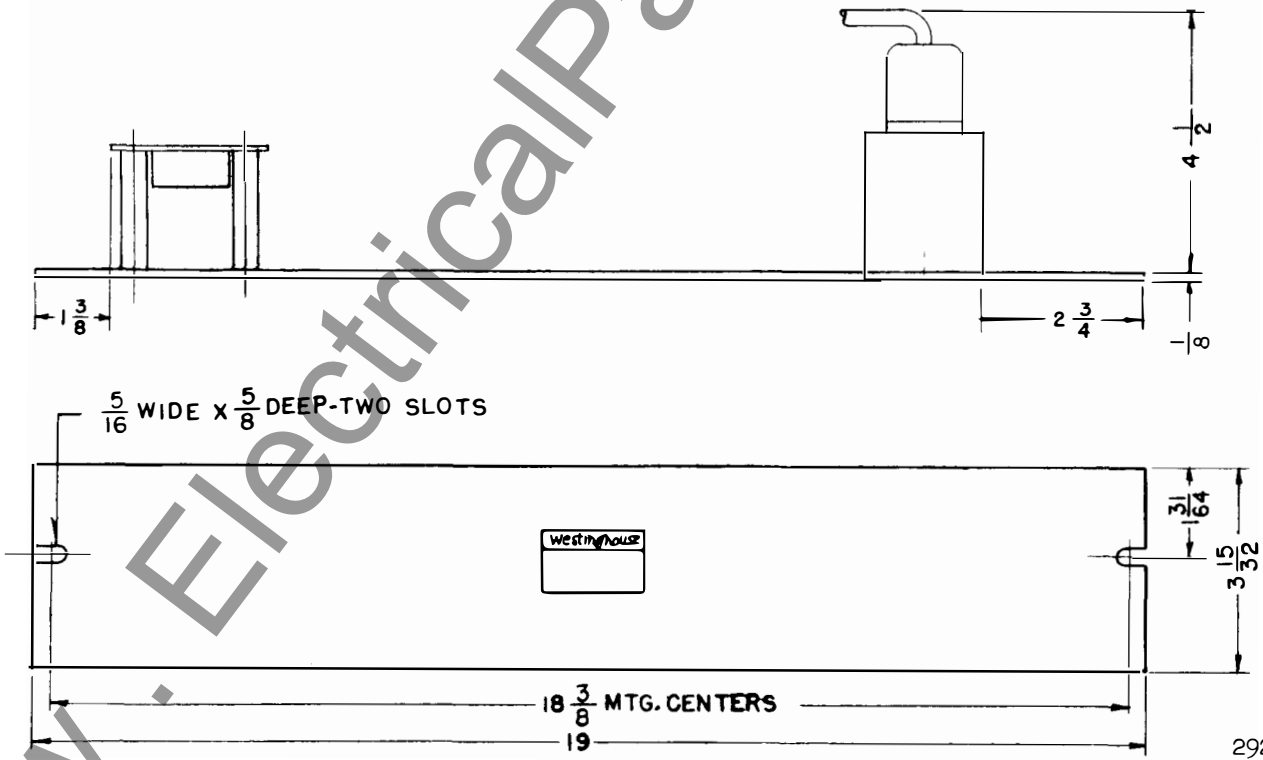

292B991

Fig. 7. Supervisory Control Auxiliary Relay Connections (Dwg. 629A552) and Outline (Dwg. 292B991).

**CONNECTIONS FOR 48-250 VOLT SERVICE AND
SUPERVISORY CONTROL APPLICATION
(CHANGES FROM JUMPERS SHOWN ON INTERNAL SCHEMATIC, FIG.2)**

250-VOLT OPERATION

FOR A 250 VOLT SUPPLY, RESISTOR UNIT 330C191H01 IS USED AS SHOWN ON APPLICATION DRAWING 329C704

FOR HZ/HZM OPERATION, THE JUMPER HAS BEEN REMOVED FROM TP-6 TO TP-7. (NOT REMOVED FOR K-DAR RELAYING).

RESISTOR UNIT SCHEMATIC:

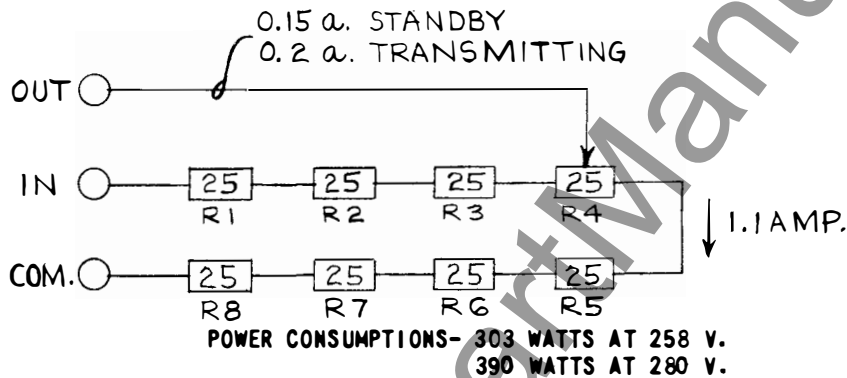

NOTE: KR SUPPLY VOLTAGE WILL BE APPROXIMATELY 144 VOLTS UNDER STANDBY CONDITION WHEN BATTERY VOLTAGE IS 280 VOLTS.

125-VOLT HZ/HZM OPERATION

JUMPER TP-7 AND TP-8 IS REMOVED.

48 VOLT OPERATION

ON PRINTED CIRCUIT BOARD ADDITIONAL JUMPERS ARE CONNECTED AS FOLLOWS:

- BETWEEN TP8 AND TP9
- BETWEEN TP5 AND J12
- BETWEEN TP1 AND TP2
- BETWEEN TP3 AND TP4

IN THE FT CASE, JUMPERS ARE CONNECTED ACROSS R60 AND R64, AND THE CONNECTION BETWEEN R64 AND DIODE CR8 IS REMOVED.

IN ADDITION, FOR 48-VOLT SUPERVISORY CONTROL, R59 IS CONNECTED INTO THE CIRCUIT.

Fig. 8. Connections, 48-250 Volts and Supervisory Control (Dwg. 407C971)

TRANSMITTER OUTPUT FILTER FL-3 CONNECTIONS

<u>LINE</u>	<u>FREQUENCY RANGE</u>	<u>COIL</u>	<u>COIL CONNECTIONS</u>	<u>PARALLEL CAPACITOR CONNECTIONS</u> Δ
1	27.7 KHZ-30.0 KHZ	L-1	(1-5) (3-6)	6-8-9-10-11
2	29.8 KHZ-33.1 KHZ	L-1	(1-5) (3-6)	6-8-10-11
3	31.8 KHZ-36.0 KHZ	L-1	(1-5) (3-6)	6-8-9-11
4	35.4 KHZ-39.0 KHZ	L-1	(1-5) (3-6)	6-8-11
5	38.0 KHZ-41.0 KHZ	L-1	(1-2) (3-6)	6-8-9-10-11
6	40.3 KHZ-45.0 KHZ	L-1	(1-2) (3-6)	6-8-10-11
7	43.0 KHZ-49.0 KHZ	L-1	(1-2) (3-6)	6-8-9-11
8	47.7 KHZ-56.0 KHZ	L-1	(1-2) (3-6)	6-8-11
9	49.5 KHZ-58.5 KHZ	L-1	(1-2) (3-6)	6-8-9-10
10	57.0 KHZ-72.3 KHZ	L-1	(1-2) (3-6)	6-8-10
11	67.0 KHZ-76.0 KHZ	L-2	(1-4) (6-7)	6-8-9-11
12	75.0 KHZ-88.0 KHZ	L-2	(1-4) (6-7)	6-8-11
13	77.5 KHZ-93.0 KHZ	L-2	(1-4) (6-7)	6-8-9-10
14	89.3 KHZ-114.5 KHZ	L-2	(1-4) (6-7)	6-8-10
15	102.7 KHZ-147.0 KHZ	L-2	(1-4) (6-7)	6-8-9
16	136.6 KHZ-210.0 KHZ	L-2	(1-4) (6-7)	6-8

Δ =CONNECTION FROM 6 TO 8 IS MADE BENEATH TERMINAL PLATE ON ALL SETS AT THE FACTORY.

Fig. 9. Connections - Output Filter (Dwg. 149A420)

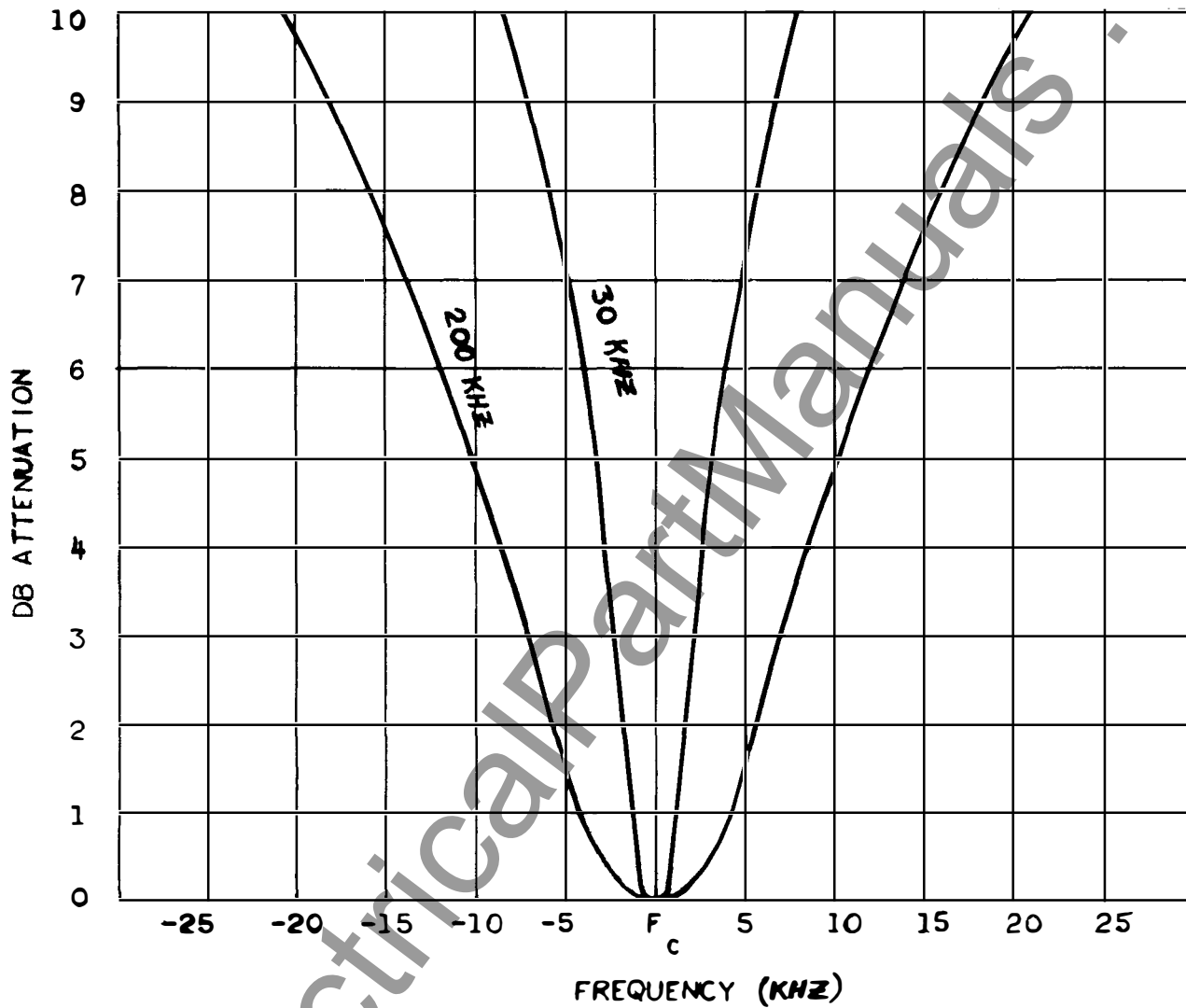
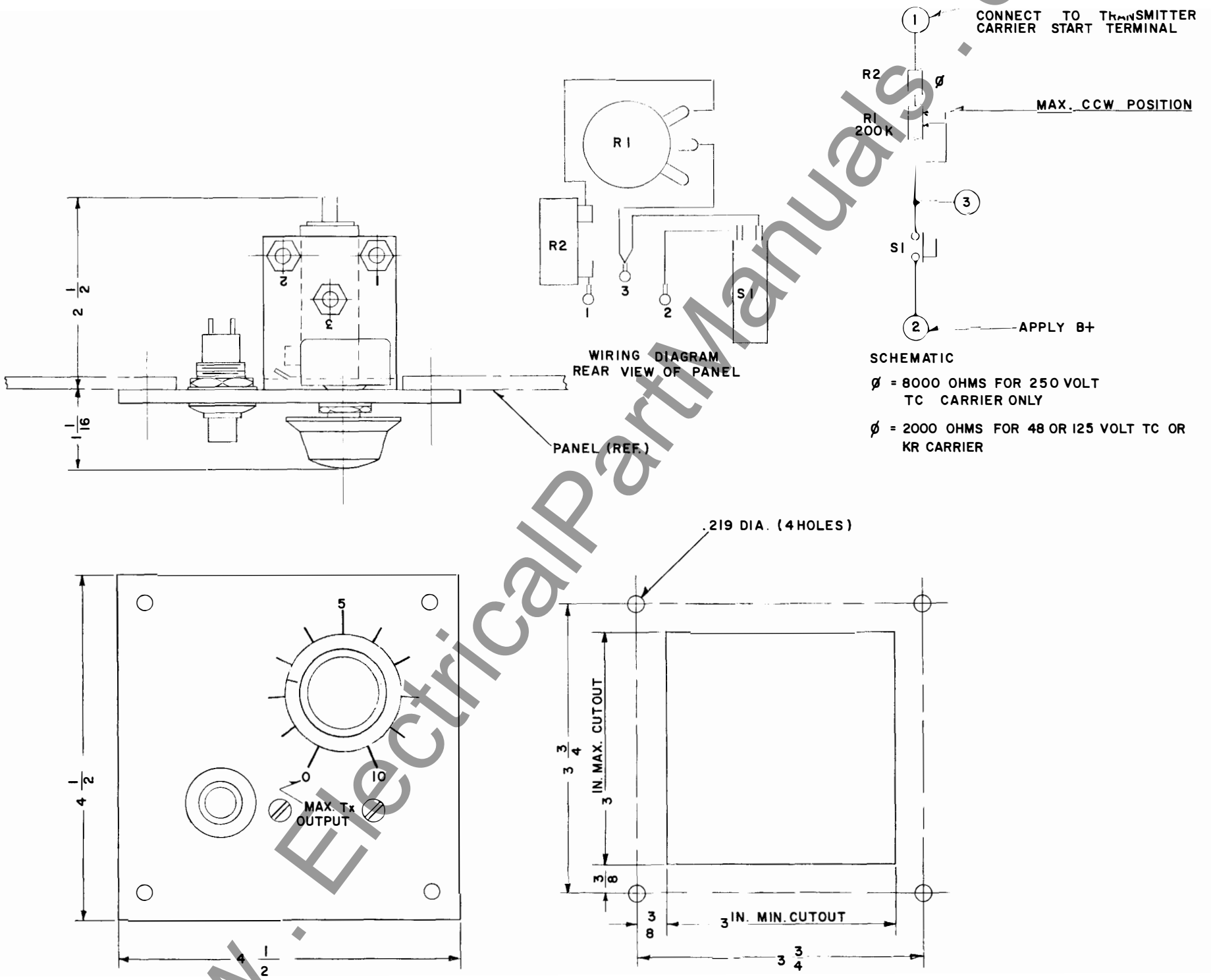

Fig. 10. Transmitter Output Filter Selectivity (Dwg. 377996)

Fig. 11. Reserve Signal Detector Outline (Dwg. 329C703)



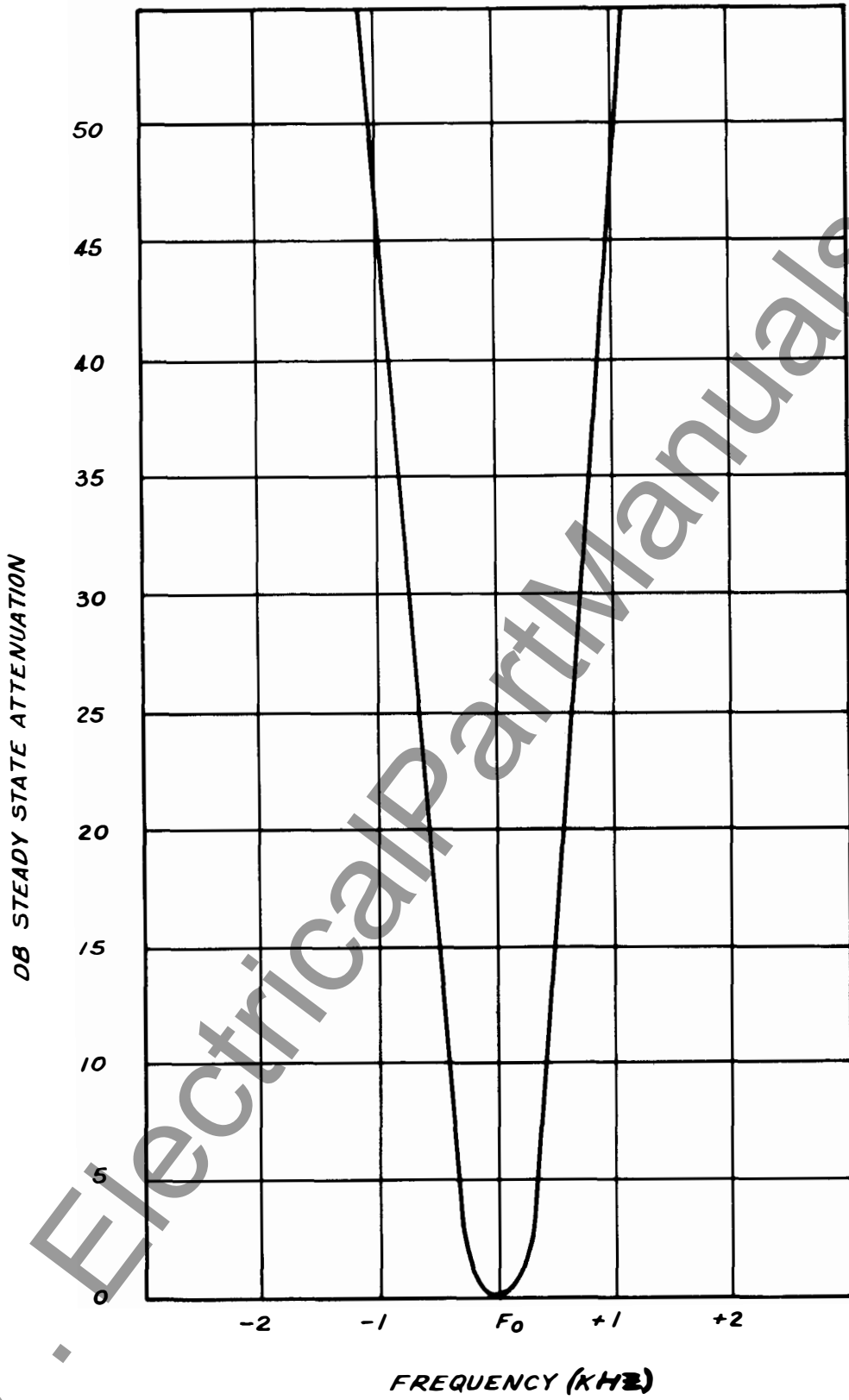
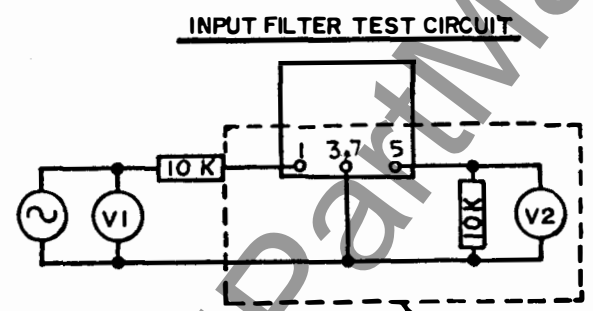
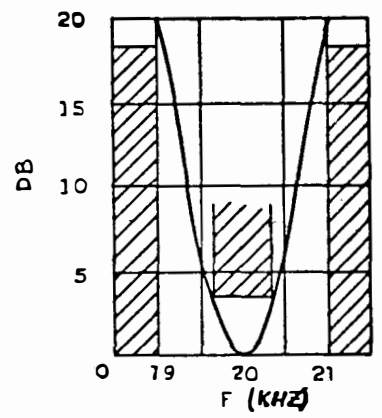
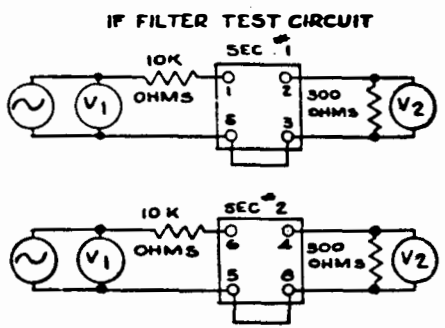
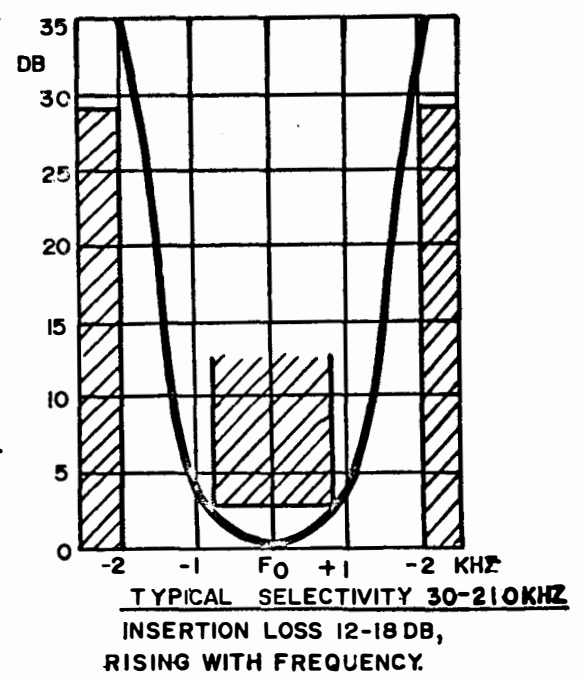

Fig. 12. Receiver Selectivity (Curve #377993)



FOR BOTH FILTERS,
 $DB = 20 \log \frac{V1}{V2}$



Each section FL-2 requirement
 with typical selectivity curve.
 Insertion loss 26 DB max.
 Including matching resistor.

Fig. 13. Receiver Filter Limits (Curve #619488)

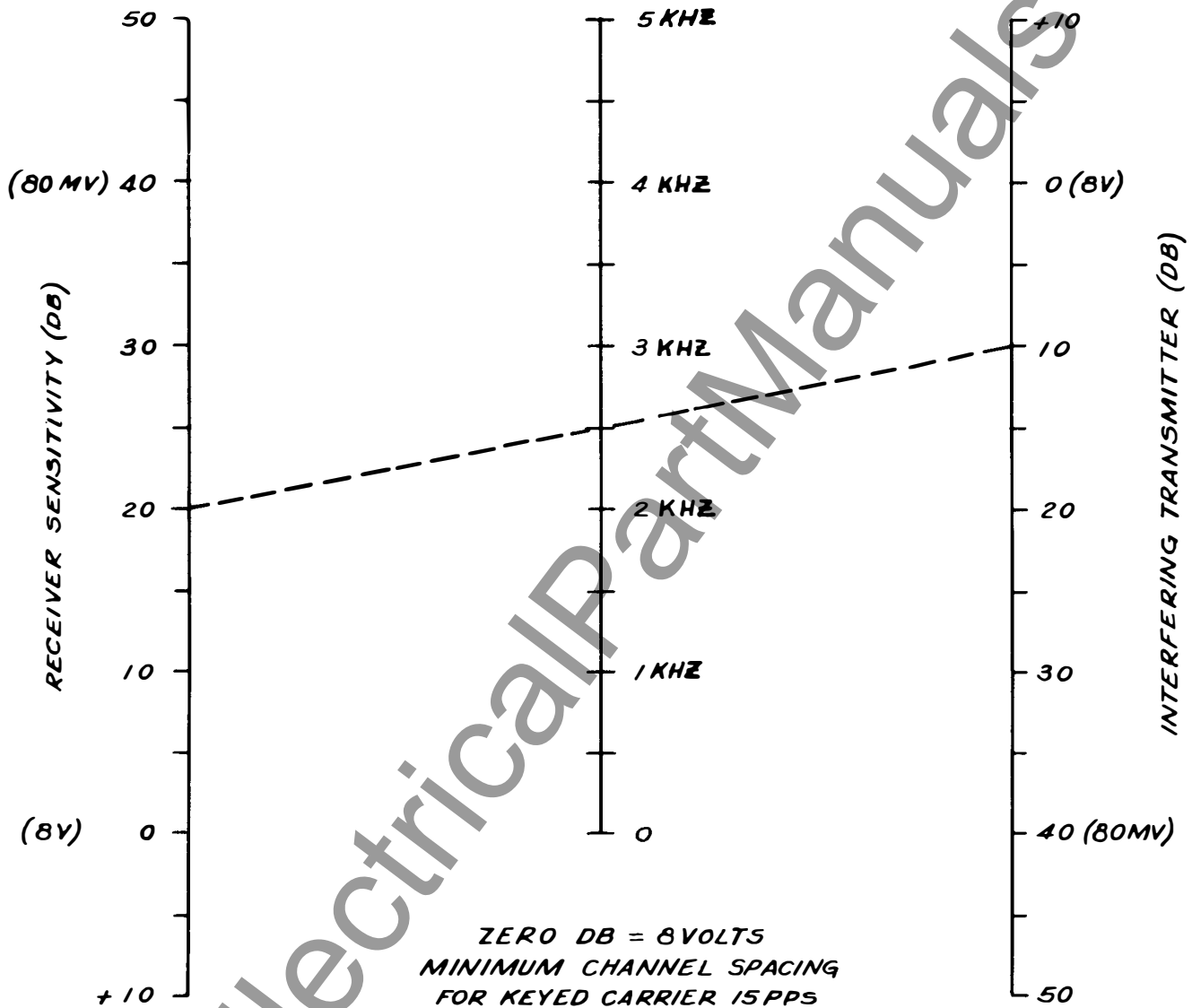
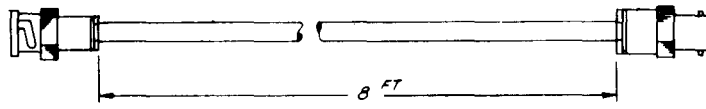
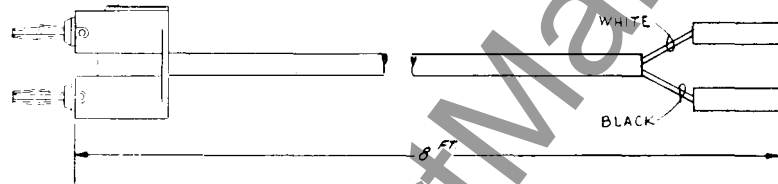

Fig. 14. Minimum Channel Spacing (Curve #377998)



Coaxial Lead... 756D346 G02



Output Lead... 756D346 G03

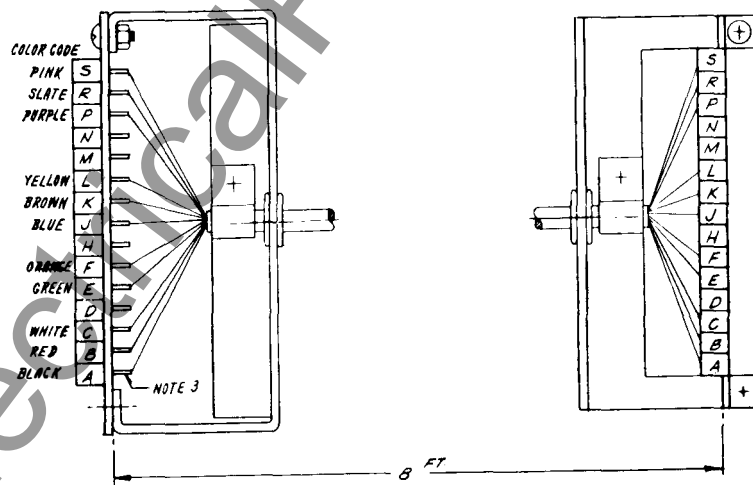

Main Harness... 756D346 G04

Fig. 15. Test Harness - (Complete Set)

www.ElectricalPartManuals.com

www.ElectricalPartManuals.com



WESTINGHOUSE ELECTRIC CORPORATION
RELAY-INSTRUMENT DIVISION

NEWARK, N. J.

Printed in U.S.A.

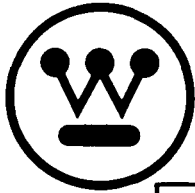

INSTALLATION • OPERATION • MAINTENANCE I N S T R U C T I O N S

TYPE KR CARRIER RELAYING TRANSMITTER-RECEIVER

Flexitest Case Mounted —with provision for rear-mounter Voice Adapter Accessories.	Style
KR Reserve Signal Detector	470D167 GO2
250 Volt Resistor Unit	330C191 H01
Test Harness (Complete Set)	756D346 G01
Coaxial Lead	756D346 G02
Output Lead	756D346 G03
Main Harness	756D346 G04

TABLE OF CONTENTS

Introduction	Page 2
Specifications	Page 2
Description	
General	Page 3
Mechanical	Page 3
Electrical	
Transmitter	Page 4
Receiver	Page 4
Transmitter Control Circuits	Page 5
Reserve Signal Detector	Page 5
Communications	Page 5
Relaying Control Circuits	Page 5
Installation	
General	Page 6
Connections	
External	Page 6
Internal	Page 7

Adjustments

Transmitter	Page 7
Receiver	Page 7
Reserve Signal Detector	Page 8
250-Volt Resistor Unit	Page 8
Frequency Change	Page 8
Maintenance	Page 9
Application	Page 13
Electrical Parts List	Page 14

LIST OF TABLES

Table	
1 D-C Pin Jack Measurements with Reference to B-	Page 10
2 Transistor DC Measurements with Reference to B-	Page 11
3 D-C Bleeder Measurements with Reference to B-	Page 12
4 Typical RF Signal Measurements for Receiver	Page 12
5 Typical RF Signal Measurements for Transmitter	Page 13

LIST OF ILLUSTRATIONS

Figure		References
1	Outline – Flexitest Case	540D753
2	Internal Schematic	540D780
3	Relaying Control Circuits (HZ/HZM)	1-329C704
4	Relaying Control Circuits (K-Dar)	3-329C704
5	Relaying Control Circuits (GCX/GCY).....	2-329C704
6	Component Location.....	540D781
7	Supervisory Control Receiver Connection	223B498
8	Connections, 48-250 volts and Supervisory Control.....	407C971
9	Transmitter Output Filter Connections	149A420
10	Transmitter Output Filter Selectivity.....	C377996
11	Reserve Signal Detector – Outline and Schematic	329C703
12	Receiver Selectivity	C377993
13	Receiver Filter Limits	C377995
14	Minimum, Channel Spacing	C377998
15	Test Harness	756D346

CAUTION The voltages encountered in this equipment are dangerous to life. To be safe, disconnect the power source and close the grounding switch when servicing the equipment.

INTRODUCTION

The Type KR Relaying Transmitter-Receiver is designed for Distance Relaying, Telemetry, Supervisory Control and Sleet Detection. Facilities are provided for a plug-in type voice adapter. The basic design is for operation from 125-volt station batteries. However, the apparatus may also be operated from 48-volt or 250-volt station batteries by means of various internal connections. These various connections as well as most of the adjustments are made at the factory, although they can be changed in the field.

Although designed primarily for operation with Westinghouse protective relays, this apparatus may also be coordinated with other types of directional-distance relays and with most other contact keyed devices.

SPECIFICATIONS

Frequency Range.....	30-kHz to 200kHz
Channel Attenuation Rating	40-db
Transmitter Power Output.....	1.0 watt with a 125 V.D.C. supply. 0.5 watt with a 48-volt d-c supply.
Transmitter Harmonic Output	At least 46-db below fundamental.
Transmitter Output Impedance.....	Matches one 60-ohm coax. cable. (Suitable for 50-70 ohm cable.)
Transmitter Output Filter Selectivity	See Fig. 10
Transmitter and Receiver Oscillator and Frequency Stability	From -20° C to +55° C with simultaneous voltage variations from 105 to 140 VDC, the frequency remains within ±20 Hz. *

Permissible Battery Voltage Ripple	7-½%
Ambient Temperature Range	- 20° C to + 55° C.
Receiver Maximum Sensitivity025 volts for 10 ma. output.
Receiver Selectivity	See Fig. 12
Receiver Signal-to-Noise Ratio Requirements	12-db
Minimum Channel Spacing	See Fig. 14
Power Input	115-ma at 48 VDC, 200-ma at 125 VDC, 1.28 amperes at 250 VDC.
Carrier On-Off Keying	Requires one pair of contacts capable of keying 8-ma DC at an open circuit voltage of 125 VDC.
Weight (With Flexitest Case)	Approximately 16-lbs.

CAUTION Refer application to Westinghouse when other transmitters are to be connected to the same coax cable as certain conditions may result in damage to the output transistors.

such as potentiometers, jack, test points, crystals, transistors, etc. External connections and the Schematic Diagram are shown by Fig. 2. The numbered terminals shown as squares apply to the external terminals.

DESCRIPTION

Mechanical

This apparatus is supplied in a Flexitest case and may be either flush or projection mounted in order to match other switchboard equipment. The outline dimensions and also the drilling plan for flush and projection mounting are shown by Fig. 1. The majority of the parts are mounted on a printed circuit board. This board may be readily removed as follows:

1. Remove the two output plugs from the red and black jacks.
2. Disconnect the receiver input coaxial cable connector.
3. Loosen the two screws at the top of the board.
4. Loosen the two screws at the bottom of the board and pull them out as far as they will extend.
5. Pull board down to disengage the terminals and lift out.

The transmitter output filter may be removed by removing four mounting screws from the bottom of the case and disconnecting the coaxial cable.

Fig. 6. shows the location of major components

Provisions are made for plugging the Voice Adapter Unit in the rear of the relaying equipment. Octal socket marked X-4 on the rear of the set accommodates the adapter plug. A buckle type strap on each side of the adapter holds the unit in place after it has been plugged in. The normal projection for a rear mounted Voice Adapter is 3-inches beyond that of the relaying equipment. When the KR Relaying Unit is supplied with the adapter, a patch cord is available on separate order. This patch cord plugs into the telephone jacks on the adapter and provides an extension to a conveniently located terminal board.

The panel cutout information necessary for mounting the Reserve Signal Detector is shown by Fig. 11. This unit consists of a potentiometer and pushbutton switch mounted on a small panel, itself suitable for switchboard mounting.

For 250-volt operation, separate auxiliary resistors are required, as shown in Fig. 8.

Electrical

Transmitter

The transmitter is made of four main stages in -

cluding an oscillator, driver, power amplifier, and an output filter. In the oscillator, the crystal is operated as a resonant circuit between the collector of one transistor and the base of the other. The feedback is supplied through a capacitor from the collector of the second transistor to the base of the first transistor. The frequency is independent of voltage or temperature changes of the transistors. Thus the frequency stability is the stability of the crystal.

The input to the driver stage Q-10 is controlled by potentiometer, R-42 which also controls the transmitter power output. In HZM relaying CARRIER STOP provides about +40 volts for blocking. This is applied to Q-10 through T-6. Diode CR-5 prevents damage to the transistor when this positive voltage is applied to the collector. For CARRIER START (when in the blocked position) a small positive voltage is applied to the collector of Q-10 by means of bleeder resistors R-67 and R-68.

The power amplifier consists of two transistors Q-12 and Q-15, which are operated as class B amplifiers in push-pull. Resistors R-52 and R-55 are for stabilization.

The output transformer, T-7, matches coaxial cables of 50 to 70 ohms.

Resistor R-66 tends to keep the source impedance constant to permit proper tuning of the output filter.

The output filter consists of coils L-1 and L-2, capacitors C-19 through C-22. The filter is tunable, and is provided to attenuate harmonics and other spurious outputs. It should be noted that the filter contains no shunt elements, resulting in a reverse impedance free of "across the line" resonances.

Receiver

The receiver is a superheterodyne in order to obtain constant selectivity regardless of the channel frequency. (See Fig. 12) The major stages include an input filter, attenuator, oscillator, mixer, IF filters, IF amplifiers, detector and a D-C power output stage.

The receiver sensitivity is adjusted by means of the continuously variable input control R-1 and by connecting or disconnecting resistors R-73 and R-74 in the IF stages.

The receiver oscillator (Q-2 and Q-3) is basic-

ally the same as the transmitter oscillator. The frequency is 20-kHz above the incoming signal frequency.

The receiver channel frequency is determined by the input filter and the oscillator crystal. The frequency may be changed readily since both the filter and the crystal are plug-in components.

Mixing is accomplished by feeding the incoming signal to the emitter and the receiver oscillator signal to the base of the mixer Q-1. Mixer oscillator requirements are met through adjustment of potentiometer R-4. Injection into two separate elements, base and emitter, provides a circuit capable of handling greater signal level variations than one in which injection is made into only a single element such as the base.

This receiver uses an IF frequency of 20-kHz. The overall selectivity is determined primarily by the IF filter FL-2. Typical characteristics of this filter are shown in Fig. 13. The IF amplifier consists of transistors Q-4, Q-5 and Q-6.

The detector is a full wave bridge rectifier. This rectifier in conjunction with the IF amplifier Q-6, provides the necessary power to drive the D-C power output stage Q-7. The final output stage Q-7 will supply approximately 18 milliamperes to a standard 1700 ohms distance relay RRRH coil and its associated 500 ohm alarm coil. It may also be used to drive other relay coils such as is shown by Fig. 7, Supervisory Control Connections.

Transmitter Control Circuits

In the standby condition, although the oscillator is running, the transmitter driver has no emitter bias which results in no output.

Positive voltage applied to terminal 15 supplies this bias through a voltage dividing network, and transmitter output results. The actual configuration of the network is a function of supply voltage and application (Relaying, Telemetry, etc.) and is discussed in the Adjustments section.

Output may be stopped in several ways. The method used with K-DAR relays is to remove the positive voltage applied to terminal 15. In the case of distance relaying with Westinghouse HZ/HZM relays, application of a positive voltage to terminal

18 will stop the transmitter output. Output may also be stopped by removal of negative battery from terminal 18.

Reserve Signal Detector

The Reserve Signal Detector is shown by Fig. 11. Effectively R-1 is a remote transmitter output control. This control is obtained through varying the driver Stage (Q-10) emitter bias, and is effective over a 25-db range of transmitter output. The detector is switched into service by S-1. By adjusting R-1 for a given receiver relay current at the far end of the channel, a relative measure of the channel attenuation may be obtained. This is discussed further in the section on Adjustments.

Communications

The transmitter output is reduced approximately 6-db when the Type KR voice adapter attachment is used. Relaying takes preference, and full output is obtained when full voltage is supplied to terminal 15.

Relaying Control Circuits

Figs. 3, 4 and 5 show simplified diagrams of the relaying control circuits.

1. K-DAR and GCY Relaying (Figs. 4 and 5)

The control of the carrier set is obtained through the CARRIER START and CARRIER STOP contacts. These contacts are shown in their normal standby condition.

The K-DAR or GCY relays operating from the voltage and current on the transmission line, detect and determine the direction of a line fault and thereby control the carrier transmitter and receiver.

The control of the carrier set is such as to start the transmission of carrier when fault power on the transmission line is flowing out of the line section being protected. Conversely, when fault power is flowing into this line section, the control is such as to block the transmitter and keep it from being turned on by secondary functions such as reserve signal detection and communication, should these functions be in use at the same time. Should carrier be received from the remote station, the hold coil and alarm coil will energize through transistor Q-7 in the receiver.

When carrier start operation occurs, the CARRIER

START contact opens applying a positive voltage (see Figs. 4 and 5) to terminal 15 of the carrier set. This puts a potential on the driver stage in the transmitter and also applies proper bias for the power amplifier.

When a carrier stop operation occurs, the CARRIER STOP contact closes, which removes B+ (terminal 15) from the driver and the power amplifier stages in the transmitter. CARRIER STOP, terminal 18, on the carrier set is permanently connected to terminal 14, for K-DAR and GCY relaying.

2. HZM Relaying (Fig. 3)

The control of the carrier set is effected by the CARRIER START and the CARRIER STOP contacts. These contacts are shown in their normal standby condition.

The HZ-HZM relays operating from the voltage and current on the transmission line, detect and determine the direction of a line fault and thereby control the carrier transmitter and receiver.

The control of the carrier set is such as to start the transmission of carrier when fault power on the transmission line is flowing out of the line section being protected. Conversely, when fault power is flowing into this line section, the control is such as to block the transmitter and keep it from being turned on by secondary functions such as reserve signal detection and communication, should these functions be in use at the same time. Should carrier now be received from the remote station, the hold coil and alarm coil will energize through transistor Q-7 in the receiver.

When carrier start operation occurs, the CARRIER START contact closes applying the full battery supply voltage to terminal 15 of the carrier set. This puts a potential on the driver stage in the transmitter and also applies proper bias for the power amplifier.

When a carrier stop operation occurs, the CARRIER STOP contact opens. This applies a positive voltage (see Fig. 3) to terminal 18 which blocks the driver stage and the power amplifier stage

It is possible under certain conditions that the signals from two transmitters, attempting to block a third receiver, would be of such amplitude, phase and frequency as to cause the RRH coil current to "pulsate". It would then be possible to have a false trip.

TYPE KR CARRIER SET

In the case of the KR set for relaying 3-terminal lines, the transmitter frequencies (to avoid this possibility of false trip) should be separated by 100 Hz. All receivers and one transmitter would be at the desired center frequency. One of the other transmitters would be 100 Hz above, the other 100 Hz below this center frequency.

INSTALLATION

General

Upon receipt of a unit, whether shipped separately or in an assembly, an immediate inspection should be made. Carefully check for damage or shortages.

For necessary clearances and mounting dimensions, see the following illustrations:

Flexitest Case Mounting..... Fig. 1
Reserve Signal Detector Fig. 11

Connections

External

The external connections will vary slightly depending on the application, but in general will be as follows: (Refer to the Schematic Diagram, Fig. 2.)

Terminals 11..... Ground
12..... Coaxial Cable

13 and 19..... Supervisory Preference Contacts
14..... B- "CARRIER STOP" return
15..... Battery positive through carrier start contacts
16..... Battery positive for alarm cutoff (used with communication)
17..... B-
18..... Carrier Stop for HZM Relaying
19..... B+
20..... Relay Coil

CAUTION If the transmitter output load is removed while the transmitter is energized, the transistors in the power amplifier will be permanently damaged. A dummy load should be connected to the transmitter output if the coax is disconnected and the transmitter is to be energized.

When tuning line coupling equipment, short the coaxial cable to ground before changing taps on the Line Tuner or matching transformer.

Internal

Necessary internal connections are generally made at the factory, to customer order, before apparatus shipment. For reference purposes, these are outlined in the following tabulation. Check the proper bleeder resistors before applying voltage to the equipment.

OPERATION

48-Volt K-DAR, HZM, and GCY Relaying, Telemetering, and Supervisory
125-Volt K-DAR and GCY Relaying
125-Volt HZM Relaying, Telemetering, and Supervisory
250-Volt K-DAR and GCY Relaying
250-Volt HZM Relaying, Telemetering, and Supervisory

Various combinations of the inductors and capacitors of the transmitter output filter are required depending on the channel frequency. These are tabulated in Fig. 9.

Adjustments

This apparatus is generally tuned to and tested

BLEEDER RESISTORS IN THE CIRCUIT

at the specified channel frequency before shipment. Final adjustments must be made in the field and are described in the following paragraphs. Fig. 6 shows the locations of the various controls.

Transmitter

1. Disconnect the coaxial cable and replace with a 50, 60, or 70 ohm non-inductive resistor depending on the characteristic impedance of the cable used.

2. Fig. 9 shows typical output filter connections for various frequency ranges. In some cases it may be necessary to use either a higher or lower range to tune the filter to resonance.

3. Insert fuses F-1 and F-2 to apply power to the apparatus.

4. Connect an A-C Vacuum Tube Voltmeter (VTVM) across the non-inductive load.

R-47 and R-48

R-45, R-47 and R-48

R-41, R-45, R-47 and R-48

R-45, R-47 and R-48

R-39, R-40, R-41, R-45, R-47 and R-48

5. Unblock the transmitter by closing the CARRIER TEST SWITCH. An alternative is to jumper battery positive to terminal 15.

6. Beginning with the output control R-42 at the maximum counterclockwise position, advance it clockwise until a reading appears on the VTVM. Tune capacitor C-19 for a maximum voltmeter reading.

7. While increasing R-42, tune the output filter for maximum output until the output across the resistor is approximately 8 volts. (Approximately 5.5-volts when operating from 48-volt station battery.)

8. Open the test switch and reconnect the coaxial cable.

Receiver

1. The oscillator output control R-4 is pre-set at the factory. However, should any of the oscillator components be changed (including the transistors and the crystal) R-4 will require adjustment.

a. Connect an A-C VTVM to jacks J-3 and J-4.

b. Adjust R-4 for a 0.3 volt reading on the meter.

2. The unit is shipped to have a gain of approximately 25 millivolts (to produce 10 ma relay current) with input control R-1 in maximum clockwise position. About 10-db additional gain or 80 millivolt sensitivity can be obtained by clipping out resistor R-74, which is connected to the base of Q-4 and the B+ supply for the IF. A further 10-db gain or additional 25 millivolt sensitivity can be obtained by also clipping out resistor R-73, which is connected to the base of Q-5 and the B+ supply for the IF. Resistor R-71 and R72 have been selected at the factory to provide an overall gain of approximately 25 millivolts with R73 and R74 removed.

a. Sensitivity Adjustment for Noise

If the maximum on-frequency noise level is known or can be measured, the receiver can be adjusted for this level. Disconnect the coaxial cable and connect a 60-ohm non-inductive resistor and a VTVM across terminals 11 and 12. Energize the transmitter and output control R-42 for the same output as the maximum noise. Then adjust the receiver input control R-1 to obtain 1-ma output current. If it is impossible to obtain 1-ma output current with control R-1 in the maximum clockwise position, then clip out resistor R-74, which is connected to the base of Q-4. If the gain is still insufficient, clip out resistor R-73, which is connected to the base of Q-5. After completing the adjustment of R-1, restore the transmitter to full output.

b. Sensitivity Adjustment for Remote Signal

When the maximum on-frequency noise is unknown and cannot be conveniently measured, the receiver may be adjusted for the remote signal. First determine the channel attenuation using a Sierra voltmeter or some other convenient method. Disconnect the coaxial cable and connect a 60-ohm non-inductive resistor and a VTVM across terminals 11 and 12. Add 15-db to the channel attenuation. This compensates for average variations such as channel and voltage variations. For example, if the channel attenuation is 5-db, add this to the 15-db making a total of 20-db. Taking this from 8 volts output of the transmitter, the receiver should then be set for a sensitivity of 0.8 volts. To do this, adjust the transmitter output control R-42 for 0.8 volts and then adjust the receiver input control so as to obtain 10-ma output current. If it is impossible to obtain 10-ma output current with control R-1 in the maximum clockwise position, clip out resistor R-74, which is connected to the base of Q-4. If the gain is still insufficient, clip out resistor R-73, which is connected to the base of Q-5. After completing the adjustment of R-1, restore the transmitter to full output.

It must be kept in mind that the two preceding adjustment procedures are to be used as a guide and will cover the majority of cases; however, cases may arise where conditions change. For example, if the adjustment is made per part a., the noise may increase due to various reasons such as bad insulators, which would require adjusting the receiver to be less sensitive. In the adjustment of part b., the attenuation may increase due to sleet or line switching,

which would necessitate increasing the sensitivity of the receiver.

Reserve Signal Detector

Due to different types of operation and supply voltages, it is not practical to have a calibrated dial for this unit. However, calibration may be made at installation by recording transmitter output (either in db or volts) at various knob settings of the detector unit. Then, by adjusting the knob so as to obtain 10 milliamperes relay current at a remote receiver, any increase or decrease in line attenuation may be noted as the difference between the original setting, and the setting required to obtain the given 10 milliamperes.

250-Volt Resistor Unit

With the apparatus energized, adjust R-4 in the 250-volt resistor unit so as to obtain 125-volts at terminals 17 (B-) and 19 (B+) on the relaying set.

Frequency Change

If the frequency is changed in the field, it is necessary to change the input filter FL-1 to the desired channel frequency. This filter is of the plug-in type and may be removed by unsnapping the clamp and pulling the filter out. The transmitter oscillator crystal Y-2 must be changed to the desired channel frequency. The receiver oscillator crystal Y-1 must be changed to the desired channel frequency plus 20 kHz. Figure 9 shows the connections for the transmitter output filter. It is necessary to unsolder the existing connections and make the new connections per the chart. After completing the preceding, the tuning procedure as described under Adjustments for transmitter and receiver should then be followed.

Note also that capacitors C2 and C9 in the transmitter and receiver crystal oscillator circuits, respectively, may have to be changed. For frequencies below 110 kHz, these capacitors are 270 mmf. each. For frequencies of 110 kHz and above, the capacitors are 140 mmf. each.

CAUTION Turn power OFF before removing filters or transistors, as high transient currents may cause permanent damage to the transistors.

MAINTENANCE

Voltage values should be recorded after adjustment in order to establish reference values which will be useful when checking the apparatus. The readings

will remain fairly constant over an indefinite period unless a failure occurs. However, if transistors are changed, there may be considerable difference in these readings without the overall performance being affected.

Typical voltage and current values are given as follows. Voltages should be measured with VTVM. Readings may vary as much as $\pm 20\%$.

In the following paragraphs, the transmitter may be unblocked (transmitting) by closing the CARRIER START circuit in the case of HZM relaying, and by opening the CARRIER START circuit in the case of K-DAR and GCY relaying.

1. For D-C pin jack measurements with reference to B-, refer to Table 1.

2. For transistor D-C measurements with reference to B-, refer to Table 2.

3. For D-C bleeder measurements with reference to B-, refer to Table 3.

4. For typical RF signal measurements for receiver, refer to Table 4.

5. For typical RF signal measurements for transmitter, refer to Table 5.

6. Removal of Printed Circuit Board from Flexitest Case.

To remove the printed circuit board, unplug J-15 and J-16 located near the output filter. Loosen the two screws inside the case near the top. Loosen the slotted thumb screws at the lower end of the board and pull these screws out as far as they will extend. Also remove the receiver coaxial cable plug.

Pull board down so as to disengage the terminals, and lift out.

7. Removal of the Output Filter

After the printed board has been removed, remove the screws on the outside of the case at the bottom. Lift out filter and disconnect the coaxial cable.

8. Receiver Filters

Fig. 13 shows typical receiver selectivity curves both RF and IF. If the filters are checked in a test

setup, it is necessary to use an accurate signal generator or preferably a signal generator and a frequency counter.

9. Minimum Test Equipment for Installation

- a. Milliammeter 0-25 ma DC.
- b. 60-ohm 5-watt non-inductive resistor.
- c. A-C Vacuum Tube Voltmeter (VTVM). Voltage range 0.003 to 30 volts, frequency range 60 Hz to 230-kHz, input impedance 7.5 megohms.
- d. D-C Vacuum Tube Voltmeter (VTVM)

Voltage Range: 0.15 to 300 volts
Input Impedance: 7.5 megohms

10. Desirable Test Equipment for Apparatus Maintenance

- a. All items listed in Sections 8 and 9.
 - b. Signal Generator
- Output Voltage: up to 8 volts
Frequency Range: 20-kHz. to 230-kHz.
- c. Oscilloscope
 - d. Ohmmeter
 - e. Capacitor checker
 - f. Test harness (See Fig. 15)

APPLICATION

1. Receiver Selectivity (Fig. 12)

This shows a typical curve of the overall selectivity of the receiver under steady state conditions.

2. Transmitter Output Selectivity (Fig. 10)

Typical curves are shown so that approximate bandwidths for keying purposes can be determined for any carrier frequency between 30-kHz and 200-kHz.

3. Minimum Channel Spacing (Fig. 14)

This is a graph from which minimum channel spacing can be obtained provided the signal strength of the interfering transmitter and the sensitivity setting of the receiver are known. These can be obtained from calculations or by measurements.

For example, if the interfering transmitter voltage is measured (at the receiver) and found to be 2.5 volts, this would be 10-db down from 8 volts. This point can be located on the right hand column of the graph. Then, if the receiver sensitivity were set to operate on 0.8 volts or 20-db, this point would be located on the left hand column. A line could then be drawn through the two points as shown by the dotted line. The intersection of this line with the center line indicates the minimum channel spacing. In this case if the interfering signal is being keyed on-off, at 15 pps, the minimum spacing would be 2.5-kHz.

4. Supervisory Control Connections (Fig. 7)

When supervisory control is used with relaying, the supervisory control relay coil is connected in series with the RRH coil in place of the alarm relay. When supervisory control is used alone, a 1200-ohm resistor R3 is connected in series with the control relay coil by removing the jumper across R3, as shown in Fig. 7. In order to maintain proper mark space ratio, the relay bias current is adjusted for 9 milliamperes as indicated.

The receiver RF filter and the IF filter limits are shown on Fig. 15. Both filters are of the plug-in type and the test circuits with pin connections are shown at the top of each curve. The IF filter is divided into two separate sections. The selectivity shown is for each section, and the pin connections for each section are also shown in the test circuit sketch.

TABLE 1

D-C PIN JACK MEASUREMENTS WITH REFERENCE TO B-

Description	Jack	CONDITION A Tx-Blocked †† Rx-No Signal		CONDITION B Tx-Blocked Rx-With Signal		CONDITION C Tx-Unblocked Rx-No Signal	
		129 VDC	51 VDC	129 VDC	51 VDC	129 VDC	51 VDC
RF Input	J-2	0	0	0.3 V	0.3 V		
DC Q-1 Base	J-3	20 V	20 V	20 V	20 V		
DC R _x B+	J-4	20 V	20 V	20 V	20 V		
DC R _x Osc	J-5	7 V	7 V	7 V	7 V		
DC Q-5 Base	J-6	20 V	20 V	20 V	20 V		
B-	J-7						
DC-P1-E	J-8	110 V	32 V	110 V	32 V	110 V	32 V
DC-Q-7 Base	J-9	69 V	0 V	78 V	2.3 V	66 V	0.3 V
DC Q-7 Emit	J-10	70 V	1.0 V	78 V	1.4 V	66 V	1.0 V
DC T _x Osc	J-11	7 V	7 V	7 V	7 V	7 V	7 V
B+	J-12	129 V	51 V	129 V	51 V	129 V	51 V
DC Q-10 Base	J-13					18 V	18 V
DC Q-10 Emit	J-14					18 V	18 V
RF ma out	J-15					130 ma	130 ma
DC ma RRH and ALARM				18 ma	18 ma		

†† Tx = transmitter, Rx = receiver

TABLE 2

TYPICAL TRANSISTOR DC MEASUREMENTS WITH REFERENCE TO B-

Transistor	Condition A Tx-Blocked Rx-No Signal (Volts)			Condition B Tx-Blocked Rx-With Signal (Volts)			Condition C Tx-Unblocked Rx-No Signal (Volts)		
	E†	B†	C†	E†	B†	C†	E†	B†	C†
Q-1	20.0	20.0	0.38	20.0	20.0	0.4			
Q-2	7	7.2	1.8	7	7.2	1.8			
Q-3	6.2	8.0	2	6.2	8	2.0			
Q-4	20.0	20.0	2.6	20.0	20.0	2.8			
Q-5	20.0	20.0	2.6	20.0	20.0	2.8			
Q-6									
129 VDC	110	110	129	115	114	129			
51 VDC	32	32	51	32	32	51			
Q-7									
129 VDC	70	68	129	78	80	86			
51 VDC	1.0	0	51	1.4	2.2	7.0			
Q-8	6.2	8	2	6.2	8	2	6.2	8	2
Q-9	7	7.2	1.8	7	7.2	1.8	7	7.2	1.8
Q-10††							18	18	0.4
Q-12††							0.27	0.20	50
Q-15††							0.27	0.20	50

† E-Emitter; B-Base; C-Collector.

†† With respect to term F on printed board.

TABLE 3

D-C BLEEDER MEASUREMENTS WITH REFERENCE TO B-

Measurement	129 VDC			51 VDC		
	A†	B†	C†	A†	B†	C†
Junction R-61 and R-62 (J-8)	110V	110V	110V	32V	32V	32V
Junction R-61 and R-27 (J-10)	70V	78V	66V	1.0V	1.4V	1.0V
Junction R-27 and R-60 (P1-P)	69V	77V	65V	0	0	0
Junction CR-8 and R-64 (P1-K)	58V	58V	58V	51V	51V	51V
Junction R-48 and R-47 (J-14)	—	—	18V	—	—	18V
Junction R-45 and R-47 (TP-9)	—	—	45V	—	—	51V
Junction R-45 and R-41 (TP-8)	—	—	98V	—	—	51V

†Conditions: A — Tx-Blocked, Rx-No Signal; B — Tx-Blocked, Rx-With Signal; C — Tx-Unblocked, Rx-No Signal.

TABLE 4
TYPICAL RF SIGNAL MEASUREMENTS FOR RECEIVER
(Made with 0.1 Volt at Terminal 5 of FL1)

Check Point	25 MV Sensitivity (Volts)	80 MV Sensitivity (Volts)	250 MV Sensitivity (Volts)
With Receiver Crystal Out			
FL1-5 to Gnd.	0.1	0.1	0.1
T1-1 to Gnd.	0.1	0.1	0.1
Q1-E to Gnd.	0.05	0.05	0.05
Q1-C to Gnd.	0.07	0.07	0.07
T3-1 to Gnd.	0.07	0.07	0.07
Q4-C to Gnd.	0.07	0.07	0.07
With Receiver Crystal In			
Q4-C to Gnd.	0.5	0.5	0.25
J6 to Gnd.	0.15	0.1	0.08
Q5-C to Gnd.	7.0	1.7	0.8
Q6-B to Gnd.	2.0	0.5	0.4
Q6-C to Gnd.	13.0	10.0	8.0
T4-1 to Gnd.	13.0	10.0	8.0
T4-3 to T4-4	4.5	3.5	2.5
J9 to J10 (DC)	0.74	0.75	0.65

TABLE 5

TYPICAL RF SIGNAL MEASUREMENTS FOR TRANSMITTER

CHECK POINT	VOLTS
T5-1 to Gnd.	5.5
T5-3 to Gnd.	1.0
J13 to Gnd.	0.085
Q10-C to Gnd.	6.0
T6-2 to Gnd.	6.0
Q12-B to Gnd.	0.8
Q15-B to Gnd.	0.8
Q12-C to Gnd.	38.0
Q15-C to Gnd.	38.0
T7-5 to Gnd.	9.8
Output to Gnd.	8.0

ELECTRICAL PARTS LIST

CIRCUIT SYMBOL	FUNCTION	DESCRIPTION	MANUFACTURER'S DESIGNATION
<u>CAPACITORS</u>			
C-1	Rcvr. Bleeder	2.0 μf , $\pm 20\%$, 200 VDC, Paper	330C567 H11
†C-2	Rcvr. Osc. Feedback	140/270 μf , $\pm 20\%$, 500 VDC, Mica	330C566H43 * or 330C566H57
C-3	Rcvr. Osc. Bleeder Bypass	0.02 μf , MRC, 600 VDC, Disc	330C569 H47
C-5	Q-6 Emitter Bypass	1.0 μf , $\pm 20\%$, 200 VDC Paper	330C567 H09
C-6	Rcvr. Rectifier Bypass	Same as C-5	
C-7	B- to B+ Bypass	2 μf , $\pm 10\%$, 600 VDC, Paper	14C9400 H18
C-8	B- to GND	1.0 μf , $\pm 10\%$, 1000 VDC, Paper	14C9400 H17
†C-9	Xmtr. Osc. Feedback	Same as C-2	
C-10	Xmtr. Osc.	Same as C-3	
C-11	Key Filter	0.1 μf , $\pm 20\%$, 200 VDC, Paper	330C567 H02
C-12	Q-10 Emitter Bypass	0.25 μf , $\pm 20\%$, 200 VDC, Paper	330C567 H05
C-13	Q-10 Bleeder Bypass	Same as C-12	
C-14	PA Base Bypass	Same as C-12	

† Note: 140 μf for osc. freq. 110-kHz and above.
270 μf for osc. freq. below 110-kHz.

CIRCUIT SYMBOL	FUNCTION	DESCRIPTION	MANUFACTURER'S DESIGNATION
CAPACITORS (Concluded)			
C-18	PA Bleeder	0.5 μ f, \pm 20%, Paper	330C567 H06
C-19	Output Filter Tuning	500 μ f, Variable, Air	328C092 H01
C-20	Output Filter	390 μ f, \pm 5%, 2500 VDC, Mica	330C561 H15
C-21	Output Filter	680 μ f, \pm 5%, 2500 VDC, Mica	330C561 H21
C-22	Output Filter	1200 μ f, \pm 5%, 2500 VDC, Mica	330C561 H27
C-24	FL-2 Decoupling	Same as C-12	
C-25	Q-7 Emitter	12 mfd, \pm 20%, 200 VDC	187A177 H01
C-26	Q-7 Base Bypass	.01 mfd, \pm 10%, 100 VDC	763A219 H15
D I O D E S			
CR-1	Bridge Rectifier	General Purpose, 1N63	584C433 H02
CR-2	Bridge Rectifier	Same as CR-1	
CR-3	Bridge Rectifier	Same as CR-1	
CR-4	Bridge Rectifier	Same as CR-1	
CR-5	Q-10 Collector	Same as CR-1	
CR-6	Q-7 Base-Emitter	Type 1N457A	184A855 H07
CR-7	Voltage Regulator	Type 1N3686	185A212 H06
CR-8	Voltage Regulator	Type 1N1369	584C434 H05
CR-9	Q-7 Collector	Type 1N3811	185A089 H08
CR-10	Q-10 Emitter	Type 1N3028A	188A302 H14
CR-11	Voltage Regulator	Type 1N3024B	188A302 H12

ELECTRICAL PARTS LIST

CIRCUIT SYMBOL	FUNCTION	DESCRIPTION	MANUFACTURER'S DESIGNATION
<u>FUSE HOLDERS</u>			
FH-1	B-	For Type 3AGC Fuses	584C271 H02
FH-2	B+	Same as FH-1	
<u>FUSES</u>			
F-1	B-	3AGC 3/4 amp.	S#330C691 H12
F-2	B+	Same as F-1	
<u>FILTERS</u>			
FL-1	Rcvr. RF Bandpass	30 to 200 kHz Freq. to be specified by customer	
FL-2	Rcvr. IF Bandpass	20-kHz Fixed Freq.	* 541D086G01
<u>CONNECTORS</u>			
J-1	Printed Circuit	Printed Circuit Female Plug	54-B-7125 H03
J-2	RF Input	UG-185-U	584C292 H07
J-3	Rcvr. Osc. Output	Terminal Studs	330C592 H01
J-4	Rcvr. Mixer-Amp Supply	Same as J-3	
J-5	Rcvr. Osc. Supply	Same as J-3	
J-6	Q-5 Base	Same as J-3	
J-7	B-	Same as J-3	
J-8	Q-6 Supply	Same as J-3	

ELECTRICAL PARTS LIST

CIRCUIT SYMBOL	FUNCTION	DESCRIPTION	MANUFACTURER'S DESIGNATION
		<u>CONNECTORS (Concluded)</u>	
J-9	Q-7 Base	Same as J-3	
J-10	Q-7 Emitter	Same as J-3	
J-11	Xmtr. Osc. Supply	Same as J-3	
J-12	B+	Same as J-3	
J-13	Xmtr. Osc. Output	Same as J-3	
J-14	Q-10 Supply	Same as J-3	
J-15	Output Filter	Banana Tip Red	328C093 H01
J-16	Output Filter GND	Banana Tip Black	328C093 H02
P-1	Printed Circuit	Printed Circuit Male Plug	54-B-7126 H03
		<u>INDUCTORS</u>	
L-1	Core and Coil Assembly	11 MH Total – 6 MH Tap (Part of FL-3)	329C450
L-2	Core and Coil Assembly	2.5 MH (Part of FL-3)	329C449
L-3	RF Choke	1.0 MH, 300 ma	R-300
L-4	RF Choke	Same as L-3	
		<u>TRANSISTORS</u>	
Q-1	Rcvr. Mixer	Type 2N525	184A638H13
Q-2	Rcvr. Gsc.	Type 2N414	184A638H14

ELECTRICAL PARTS LIST

CIRCUIT SYMBOL	FUNCTION	DESCRIPTION	MANUFACTURER'S DESIGNATION
<u>TRANSISTORS (Concluded)</u>			
Q-3	Rcvr. Osc.	Same as Q-2	
Q-4	Rcvr. IF	Same as Q-1	
Q-5	Rcvr. IF	Same as Q-1	
Q-6	Rcvr. IF	Type 2N657	184A638H15
Q-7	Rcvr. Output	Type 2N698	762A585H02
Q-8	Xmtr. Osc.	Same as Q-2	
Q-9	Xmtr. Osc.	Same as Q-2	
Q-10	Xmtr. Amp.	Same as Q-1	
Q-12	Xmtr. PA	Type 2N498 or Type 2N657	184A638H07 184A638H15
Q-15	Xmtr. PA	Same as Q-12	
<u>RESISTORS</u>			
R-1	Rec. Input	25 K, $\pm 20\%$, 1/4 W, Pot.	584C276 H23
R-2	Filter Matching	10 K, $\pm 10\%$, 1/2 W	330C595 H37
R-3	Filter Load	Same as R-2	
R-4	Rcvr. Osc.	1 K, $\pm 20\%$, 1/4 W, Pot.	584C276 H19
R-5	Rcvr. Voltage Divider	6.2 K, $\pm 5\%$, 1 W	330C666 H68
R-6	Q-2 Collector	1.2 K, $\pm 5\%$, 1/2 W	330C664 H51
R-8	Rcvr. Voltage Divider	15K $\pm 1\%$, 3W	763A126H08
R-9	Rcvr. Voltage Divider	Same as R-8	

ELECTRICAL PARTS LIST

CIRCUIT SYMBOL	FUNCTION	DESCRIPTION	MANUFACTURER'S DESIGNATION
		<u>RESISTORS (Continued)</u>	
R-10	Q-2 Base	Same as R-2	
R-11	Q-2 Base	100 K, $\pm 5\%$, 1/2 W	330C665 H05
R-12	Q-3 Collector	Same as R-6	
R-13	Q-3 Emitter	390 Ohms, $\pm 5\%$, 1/2 W	330C664 H39
R-14	Q-3 Base	Same as R-2	
R-15	Q-3 Base	Same as R-11	
R-16	Rcvr. Osc. Bleeder	2.2 K, $\pm 10\%$, 1/2 W	330C595 H41
R-17	Rcvr. Osc. Bleeder	18 K, $\pm 10\%$, 2 W	330C597 H40
R-18	Rcvr. Osc.	9.1 K, $\pm 5\%$, 1/2 W	330C664 H72
R-19	Q-4 Bias	100 Ohms, $\pm 5\%$, 1/2 W	330C664 H25
R-20	Q-4 Bias	Same as R-2	
R-21	Q-5 Bias	150 Ohms, $\pm 5\%$, 1/2W	330C664 H29
R-22	Q-5 Bias	Same as R-2	
R-23	Q-6 Bias	330 Ohms, $\pm 5\%$, 1/2 W	330C664 H37
R-24	Q-6 Bias	Same as R-2	
R-25	Q-6 Emitter	Same as R-19	
R-26	Q-7 Base	Same as R-6	
R-27	Q-7 Bias	20 Ohms, $\pm 5\%$, 1/2 W	330C664 H08
R-28	Xmtr. Osc. Bleeder	Same as R-18	
R-29	Xmtr. Osc. Bleeder	Same as R-17	
R-30	Xmtr. Osc. Bleeder	Same as R-16	

ELECTRICAL PARTS LIST

CIRCUIT SYMBOL	FUNCTION	DESCRIPTION	MANUFACTURER'S DESIGNATION
		<u>RESISTORS (Continued)</u>	
R-31	Q-8 Base	Same as R-11	
R-32	Q-8 Base	Same as R-2	
R-33	Q-8 Emitter	Same as R-13	
R-34	Q-8 Collector	Same as R-6	
R-35	Q-9 Base	Same as R-11	
R-36	Q-9 Base	Same as R-2	
R-37	Q-9 Collector	Same as R-6	
R-38	Key Filter	Same as R-23	
R-39	Buffer Voltage Divider	36 K, $\pm 5\%$, 2 W	330C668 H86
R-40	Buffer Voltage Divider	Same as R-39	
R-41	Buffer Voltage Divider	Same as R-2	
R-42	Xmtr. Osc. Output	Same as R-4	
R-43	Q-10 Bias	Same as R-23	
R-44	Q-10 Bias	33 K, $\pm 5\%$, 1/2 W	330C664 H85
R-45	Buffer Voltage Divider	15 K, $\pm 10\%$, 1 W	330C596 H39
R-47	Buffer Voltage Divider	6.8 K, $\pm 5\%$, 1/2 W	330C664 H69
R-48	Buffer Voltage Divider	15 K, $\pm 5\%$, 1/2 W	330C664 H77
R-49	PA Bias	27 K, $\pm 5\%$, 2 W	330C668 H83

ELECTRICAL PARTS LIST

CIRCUIT SYMBOL	FUNCTION	DESCRIPTION	MANUFACTURER'S DESIGNATION
		<u>RESISTORS (Concluded)</u>	
R-50	Xmtr. PA	Same as R-19	
R-52	Q-12 Emitter	10 Ohms, $\pm 5\%$, 1/2 W	330C664 H01
R-55	Q-15 Emitter	Same as R-52	
R-59	Xmtr. Bleeder	47 Ohms, $\pm 10\%$, 1/2 W	330C595 H09
R-60	Recvr. Bleeder	1 K, $\pm 5\%$, 25 W	* 584C416 H62
R-61	Recvr. Bleeder	600 Ohms, $\pm 5\%$, 25 W	* 584C416 H57
R-62	Recvr. Bleeder	350 Ohms, $\pm 5\%$, 25 W	584C416 H52
R-64	Xmtr. Bleeder	1200 Ohms, $\pm 5\%$, 25 W	584C416 H64
R-66	T-7 Load	560 Ohms, $\pm 5\%$, 2 W	330C668 H43
R-67	Xmtr. Blocking	10 Ohms, $\pm 5\%$, 2 W	330C668 H01
R-68	Xmtr. Blocking	10 K, $\pm 10\%$, 10 W	330C577 H01
R-69	Q-10 Emitter	Same as R-19	
R-70	FL2 Decoupling	470 Ohms, $\pm 10\%$, 1/2 W	330C595 H21
R-71	Q-4 Emitter	Determined in test	
R-72	Q-5 Emitter	Determined in test	
R-73	Q-5 Base	220 Ohms, $\pm 10\%$, 1/2 W	187A641H11
R-74	Q-4 Base	1K, $\pm 5\%$, 1/2 W	184A763H27
R-75	Q-4 Collector	22 K, $\pm 10\%$, 1/2 W	330C595 H41
R-76	Q-5 Collector	Same as R-75	

ELECTRICAL PARTS LIST

CIRCUIT SYMBOL	FUNCTION	DESCRIPTION	MANUFACTURER'S DESIGNATION
<u>TRANSFORMERS</u>			
T-1	Rcvr. Input	Impedance Ratio 10 K; 10K	* 714B677G01
T-2	Rcvr. Osc.	Impedance Ratio 10 K: 400 ohms	* 205C043G01
T-3	Rcvr. Mixer	Impedance Ratio 25 K: 300 ohms	205C043G03
T-4	IF Output	Impedance Ratio 4 K: 500 ohms	*S#1962693, L-592289
T-5	Xmtr. Osc.	Same as T-2	
T-6	Xmtr. Buffer	Impedance Ratio 10 K: 400 ohms CT	* 714B666G01
T-7	Xmtr. Output	Impedance Ratio 1930: 60	S#1962694, L-633000
<u>TEST POINTS</u>			
TP-1	R-5	Terminal studs	330C592 H02
TP-2	R-8	Same as TP-1	
TP-3	R-17	Same as TP-1	
TP-4	R-18	Same as TP-1	
TP-5	R-28	Same as TP-1	
TP-6	R-39 & R-40	Same as TP-1	
TP-7	R-41	Same as TP-1	
TP-8	R-45	Same as TP-1	
TP-9	R-47	Same as TP-1	

ELECTRICAL PARTS LIST

CIRCUIT SYMBOL	FUNCTION	DESCRIPTION	MANUFACTURER'S DESIGNATION
<u>SOCKETS</u>			
X-1	FL-1	Octal	330C689 H01
X-2	FL-2	Same as X-1	
X-4	Rear Mounted Voice Adaptor	Same as X-1	
XY-1	Rec. Y-1	Crystal	584C606 H01
XY-2	Xmtr. Y-2	Same as XY-1	
<u>CRYSTALS</u>			
Y-1	Rcvr. Osc.	Specify Channel Freq. Plus 20-kHz.	328C083
Y-2	Xmtr. Osc.	Specify Freq. Same as Channel Frequency	328C083
<u>RESERVE SIGNAL DETECTOR</u>			
(S#470D167G02)			
R-1	Resistor, Level Control	200 K, 2 W, Pot.	184A086H27
R-2	Resistor, Limiting	2000 ohms, 2" tube.	1267296
S-1	Test Switch	SPST Normally Open	327C854 H01

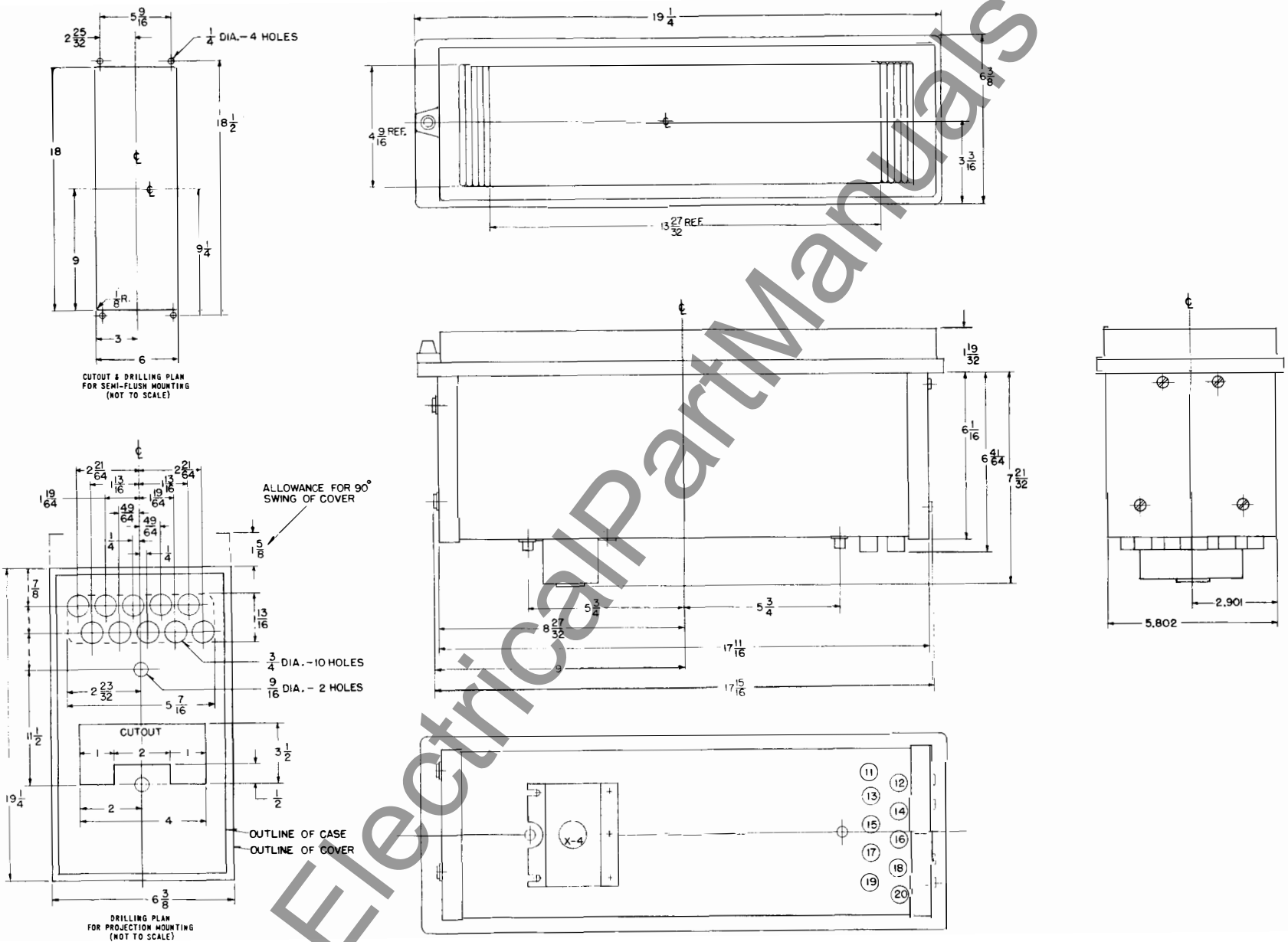
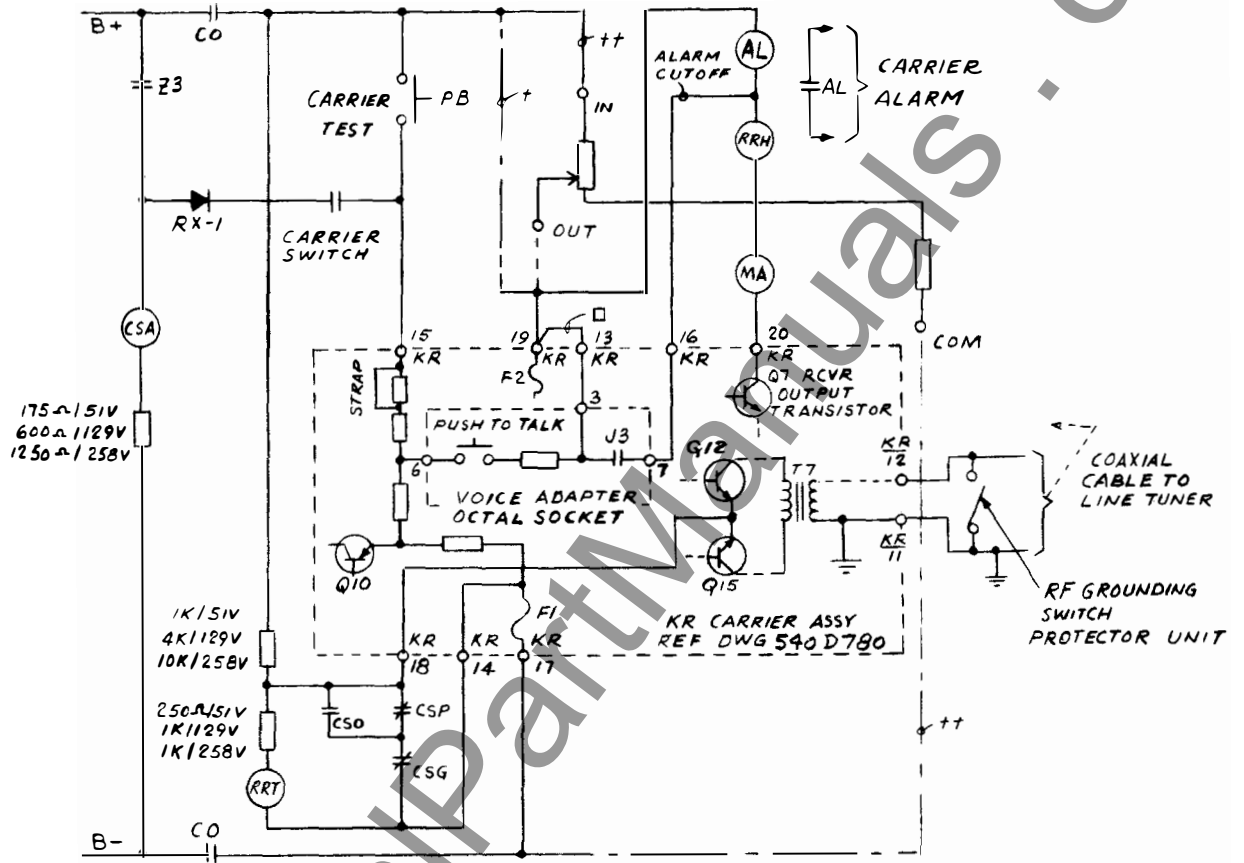

Fig. 1 Outline Drawing, (Flexitest Case) (540D753)

TYPE KR CARRIER SET



REQUIREMENTS FOR HZ/HM RELAYING

SUPPLY VOLTAGE	CARRIER START	CARRIER STOP	STRAP
5VDC	+5V, 7MA	+28V	IN
129VDC	+129V, 8MA	+40V	IN
258VDC	+258V, 8MA	+40V	OUT

- NOTES
- + FOR 51 & 129 VDC SUPPLY.
 - ++ FOR 258 VDC SUPPLY USE 330C191H01 RESISTOR UNIT REF DWG 223B497.
 - FOR SUPERVISORY CONTROL PREFERENCE CONTACTS.

- KR RELAYING TRANSMITTER /
RECV. EXTERNAL CONNECTIONS
TERMINAL - CONNECTION
- | | |
|----|---------------------------------|
| 11 | GROUND |
| 12 | COAXIAL CABLE |
| 13 | SUPERVISORY PREFERENCE CONTACT |
| 14 | CARRIER STOP B- RETURN |
| 15 | CARRIER START (POSITIVE) |
| 16 | ALARM CUTOFF FOR COMMUNICATIONS |
| 17 | B MINUS |
| 18 | CARRIER STOP (HZ/HZM) |
| 19 | B PLUS |
| 20 | RELAY COIL |

Fig. 3- Relaying Control Circuits - HZ/HZM (Dwg. 1-329C704)

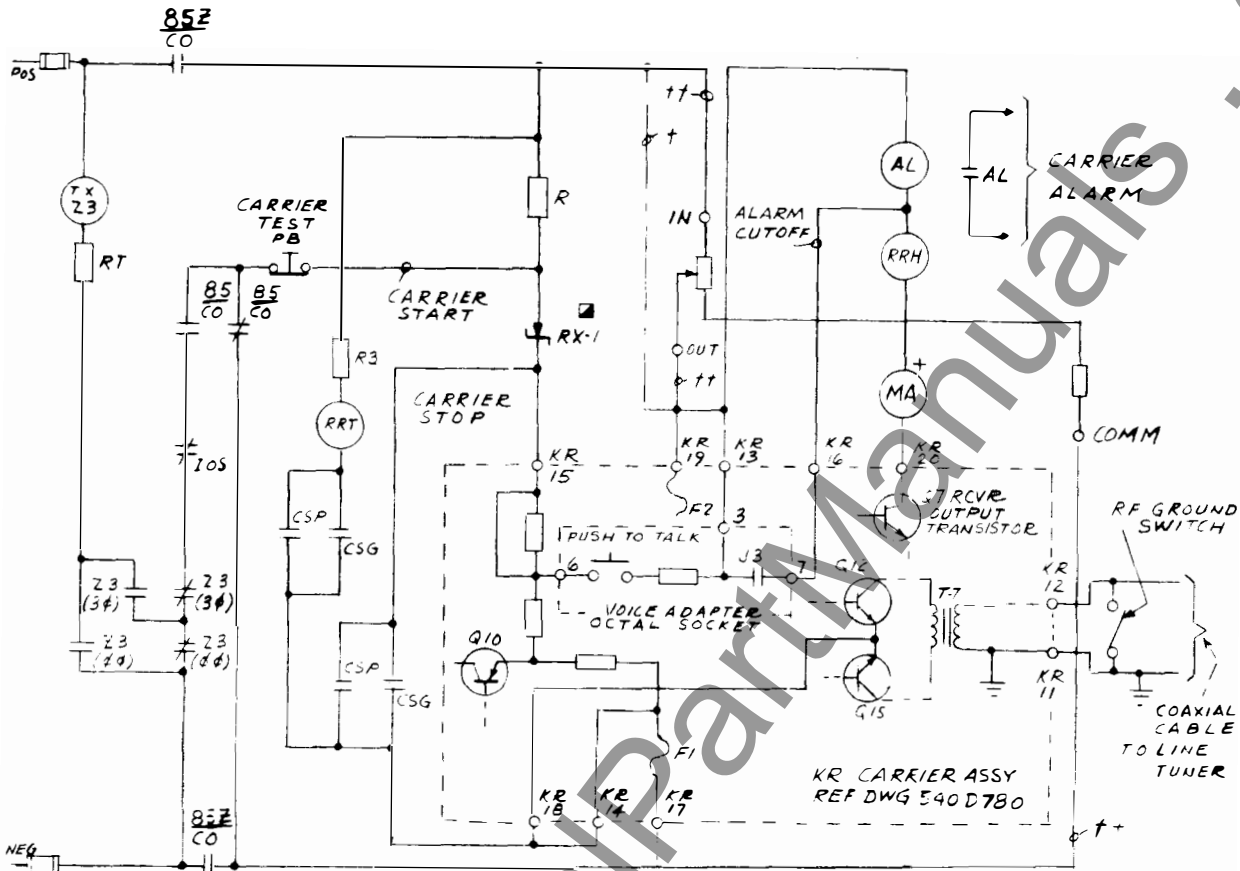

REQUIREMENTS FOR K-DAR RELAYING

SUPPLY VOLTAGE	CARRIER START	CARRIER STOP	R
51 VDC	+ 37V, 7MA	0 VOLTS	2K
129 VDC	+ 100V, 2 MA	0 VOLTS	3.75K
258 VDC	+ 100V, 2 MA	0 VOLTS	19K

NOTES

- KR RELAYING TRANSMITTER
 RECV EXTERNAL CONNECTIONS
 TERMINAL CONNECTION
- 11 GROUND
 - 2 COAXIAL CABLE
 - 13 SUPERVISORY PREFERENCE CONTACT
 - 14 CARRIER STOP B- RETURN
 - 15 CARRIER START (POSITIVE)
 - 16 ALARM CUTOFF FOR COMMUNICATIONS
 - 17 B MINUS
 - 18 CARRIER STOP (HZ/HZM)
 - 19 B PLUS
 - 20 RELAY COIL

- TYPE 1N3051 IN CARRIER AUX. RELAY
- + FOR 51 & 129 VDC SUPPLY
- ++ FOR 258VDC SUPPLY USE 330C191H01 RESISTOR UNIT REF DWG 223.B.497

Fig. 4-Relaying Control Circuits-K-Dar (Dwg. 3-329C704)

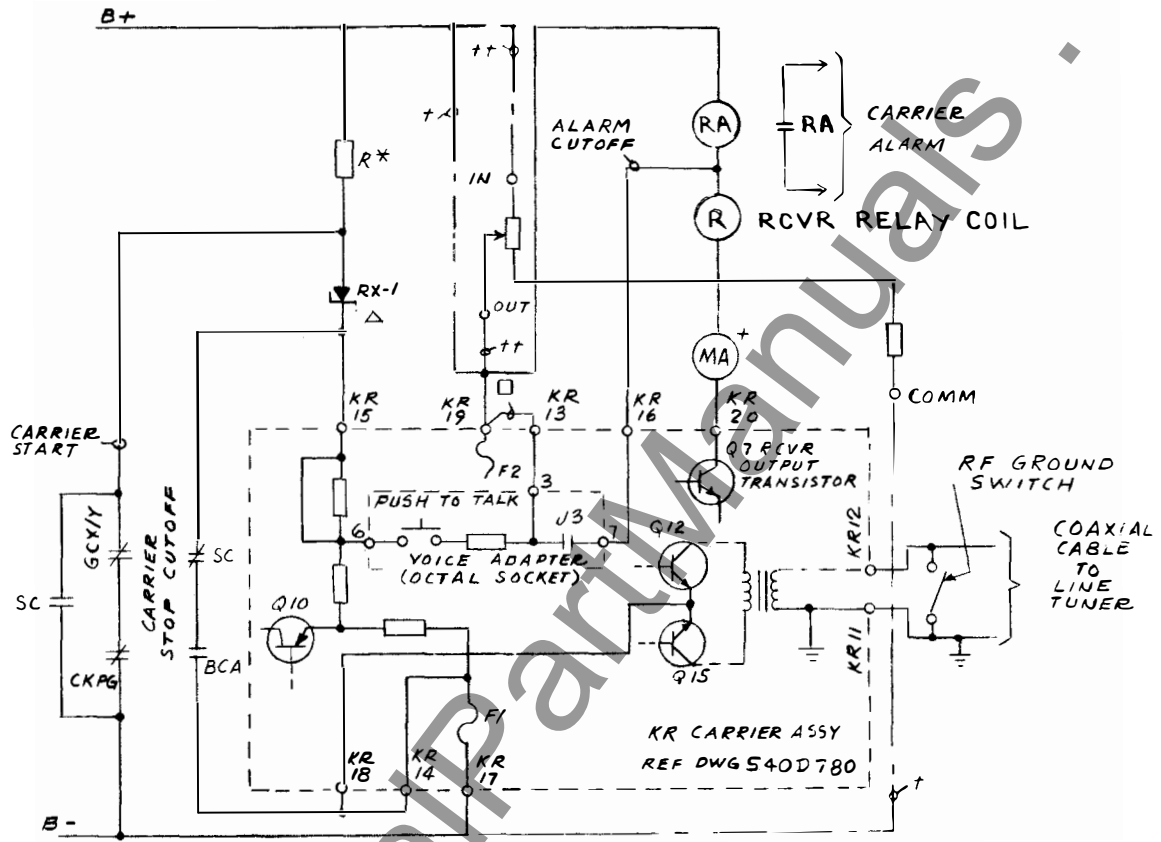

REQUIREMENTS FOR GCX/GCY RELAYING

SUPPLY VOLTAGE	CARRIER START	CARRIER STOP	R
51 VDC	+37V, 7MA	0 VOLTS	2K
129 VDC	+100V, 8MA	0 VOLTS	3.75K
258 VDC	+100V, 8MA	0 VOLTS	19.K

KR RELAYING TRANSMITTER /
RECV. EXTERNAL CONNECTIONS
TERMINAL-CONNECTION

- 11. GROUND
- 12. COAXIAL CABLE
- 13. SUPERVISORY PREFERENCE CONTACT
- 14. CARRIER STOP B- RETURN
- 15. CARRIER START (POSITIVE)
- 16. ALARM CUTOFF FOR COMMUNICATIONS
- 17. B MINUS
- 18. CARRIER STOP (HZ/HZM)
- 19. B PLUS
- 20. RELAY COIL

NOTES

- * FOR "R" USE OHMITE VITREOUS ENAMELED DIVIDOHM ADJUSTABLE 4K OR 20K 25W RESISTOR, CONNECT & ADJUST FOR VALUES SHOWN
- Δ TYPE IN 3051
- + FOR 51 & 129 VDC SUPPLY
- ++ FOR 258VDC SUPPLY USE 330C191H01 RESISTOR UNIT REF DWG 223B497
- FOR SUPERVISORY CONTROL PREFERENCE CONTACTS

Fig. 5. Relaying Control Circuits—GCX/GCY (Dwg. 2-329C704)

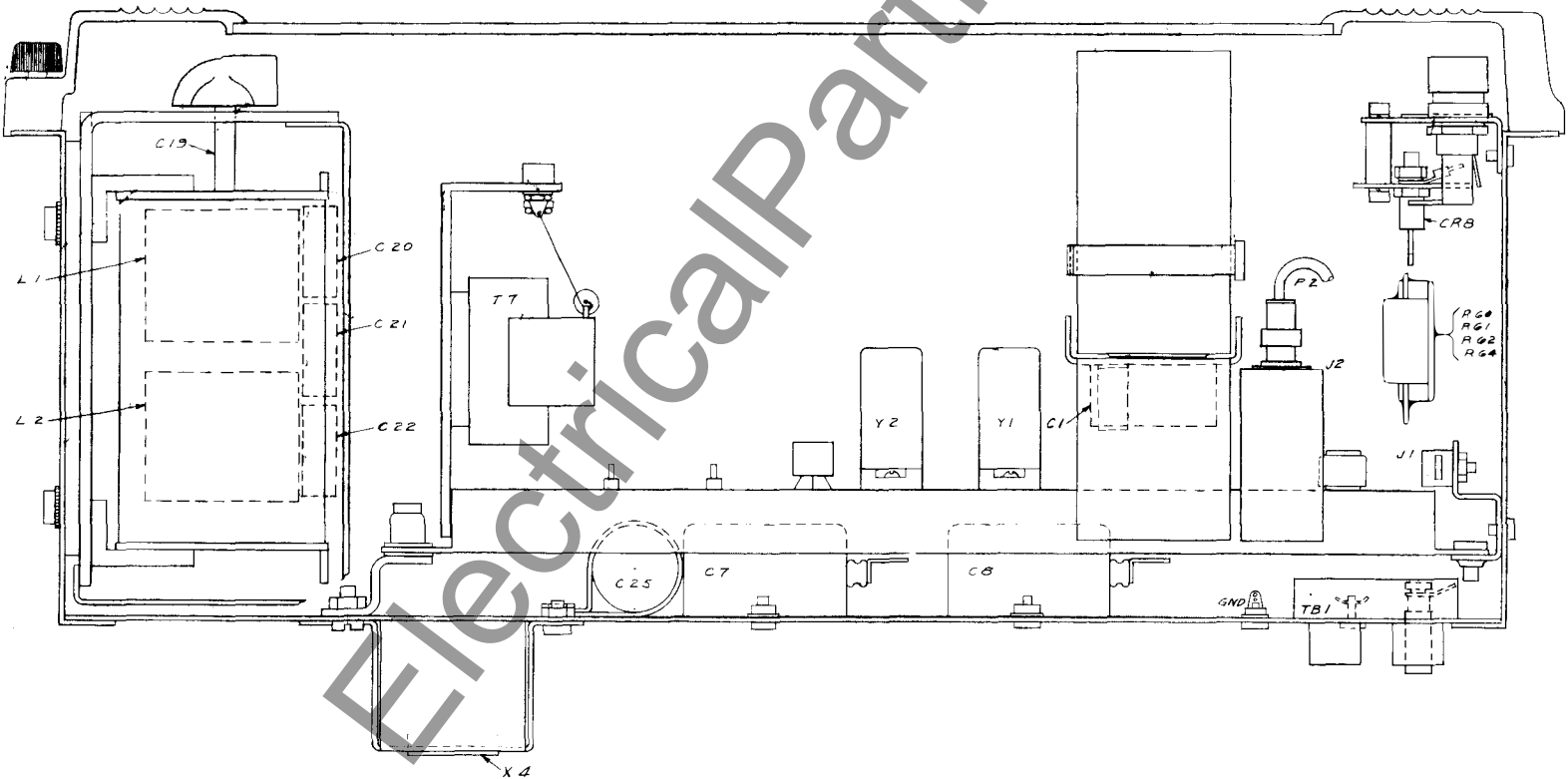
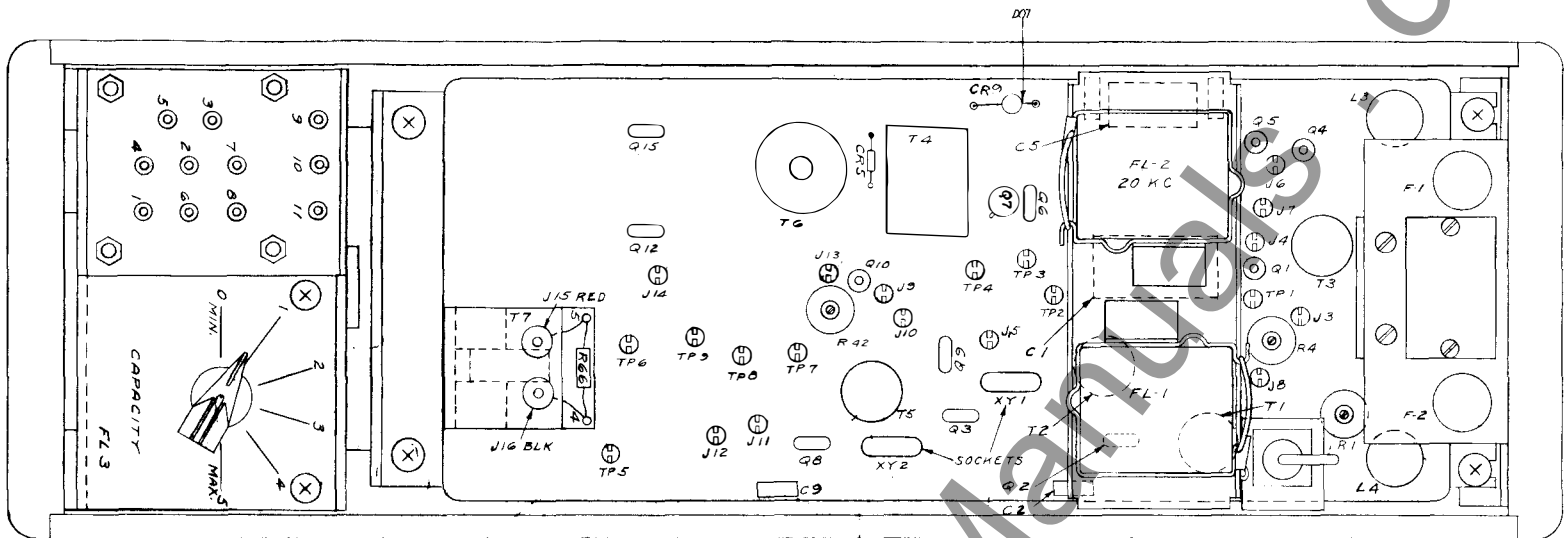
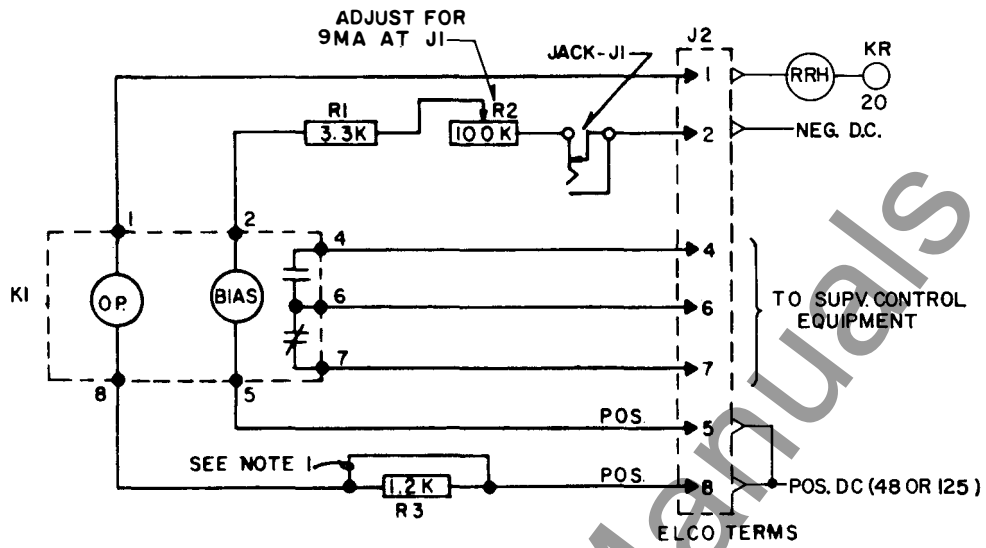
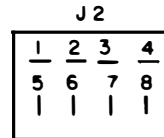

Fig. 6. Component Location (Dwg. 540D781)



NOTES:

1. REMOVE FOR KR CARRIER PLUS SUPV. CONTROL WITHOUT RELAYING.
2. POLARITY SHOWN CLOSES CONTACT BETWEEN TERMINALS 4 & 6.



AS VIEWED FROM REAR OF PANEL

629A552

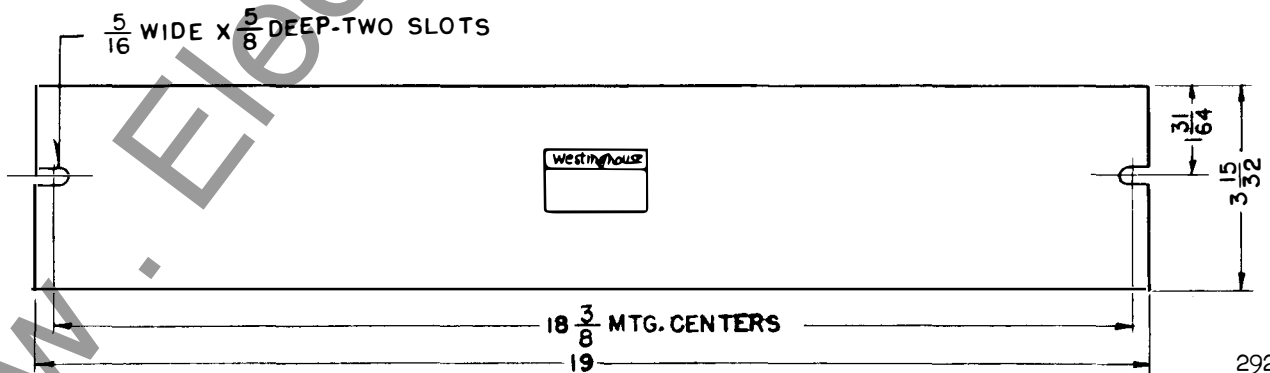

292B991

Fig. 7. Supervisory Control Auxiliary Relay Connections (Dwg. 629A552) and Outline (Dwg. 292B991).

**CONNECTIONS FOR 48-250 VOLT SERVICE AND
SUPERVISORY CONTROL APPLICATION
(CHANGES FROM JUMPERS SHOWN ON INTERNAL SCHEMATIC, FIG.2)**

250-VOLT OPERATION

FOR A 250 VOLT SUPPLY, RESISTOR UNIT 330C191H01 IS USED AS SHOWN ON APPLICATION DRAWING 329C704

FOR HZ/HZM OPERATION, THE JUMPER HAS BEEN REMOVED FROM TP-6 TO TP-7. (NOT REMOVED FOR K-DAR RELAYING).

RESISTOR UNIT SCHEMATIC:

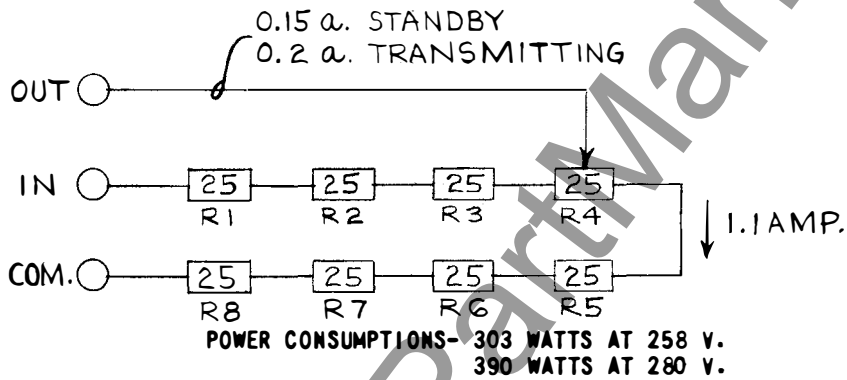

NOTE: KR SUPPLY VOLTAGE WILL BE APPROXIMATELY 144 VOLTS UNDER STANDBY CONDITION WHEN BATTERY VOLTAGE IS 280 VOLTS.

125-VOLT HZ/HZM OPERATION

JUMPER TP-7 AND TP-8 IS REMOVED.

48 VOLT OPERATION

ON PRINTED CIRCUIT BOARD ADDITIONAL JUMPERS ARE CONNECTED AS FOLLOWS:

- BETWEEN TP8 AND TP9
- BETWEEN TP5 AND J12
- BETWEEN TP1 AND TP2
- BETWEEN TP3 AND TP4

IN THE FT CASE, JUMPERS ARE CONNECTED ACROSS R60 AND R64, AND THE CONNECTION BETWEEN R64 AND DIODE CR8 IS REMOVED.

IN ADDITION, FOR 48-VOLT SUPERVISORY CONTROL, R59 IS CONNECTED INTO THE CIRCUIT.

Fig. 8. Connections, 48-250 Volts and Supervisory Control (Dwg. 407C971)

TRANSMITTER OUTPUT FILTER FL-3 CONNECTIONS

LINE	FREQUENCY RANGE	COIL	COIL CONNECTIONS	PARALLEL CAPACITOR CONNECTIONS Δ
1	27.7 KHZ-30.0 KHZ	L-1	(1-5) (3-6)	6-8-9-10-11
2	29.8 KHZ-33.1 KHZ	L-1	(1-5) (3-6)	6-8-10-11
3	31.8 KHZ-36.0 KHZ	L-1	(1-5) (3-6)	6-8-9-11
4	35.4 KHZ-39.0 KHZ	L-1	(1-5) (3-6)	6-8-11
5	38.0 KHZ-41.0 KHZ	L-1	(1-2) (3-6)	6-8-9-10-11
6	40.3 KHZ-45.0 KHZ	L-1	(1-2) (3-6)	6-8-10-11
7	43.0 KHZ-49.0 KHZ	L-1	(1-2) (3-6)	6-8-9-11
8	47.7 KHZ-56.0 KHZ	L-1	(1-2) (3-6)	6-8-11
9	49.5 KHZ-58.5 KHZ	L-1	(1-2) (3-6)	6-8-9-10
10	57.0 KHZ-72.3 KHZ	L-1	(1-2) (3-6)	6-8-10
11	67.0 KHZ-76.0 KHZ	L-2	(1-4) (6-7)	6-8-9-11
12	75.0 KHZ-88.0 KHZ	L-2	(1-4) (6-7)	6-8-11
13	77.5 KHZ-93.0 KHZ	L-2	(1-4) (6-7)	6-8-9-10
14	89.3 KHZ-114.5 KHZ	L-2	(1-4) (6-7)	6-8-10
15	102.7 KHZ-147.0 KHZ	L-2	(1-4) (6-7)	6-8-9
16	136.6 KHZ-210.0 KHZ	L-2	(1-4) (6-7)	6-8

Δ =CONNECTION FROM 6 TO 8 IS MADE BENEATH TERMINAL PLATE ON ALL SETS AT THE FACTORY.

Fig. 9. Connections - Output Filter (Dwg. 149A420)

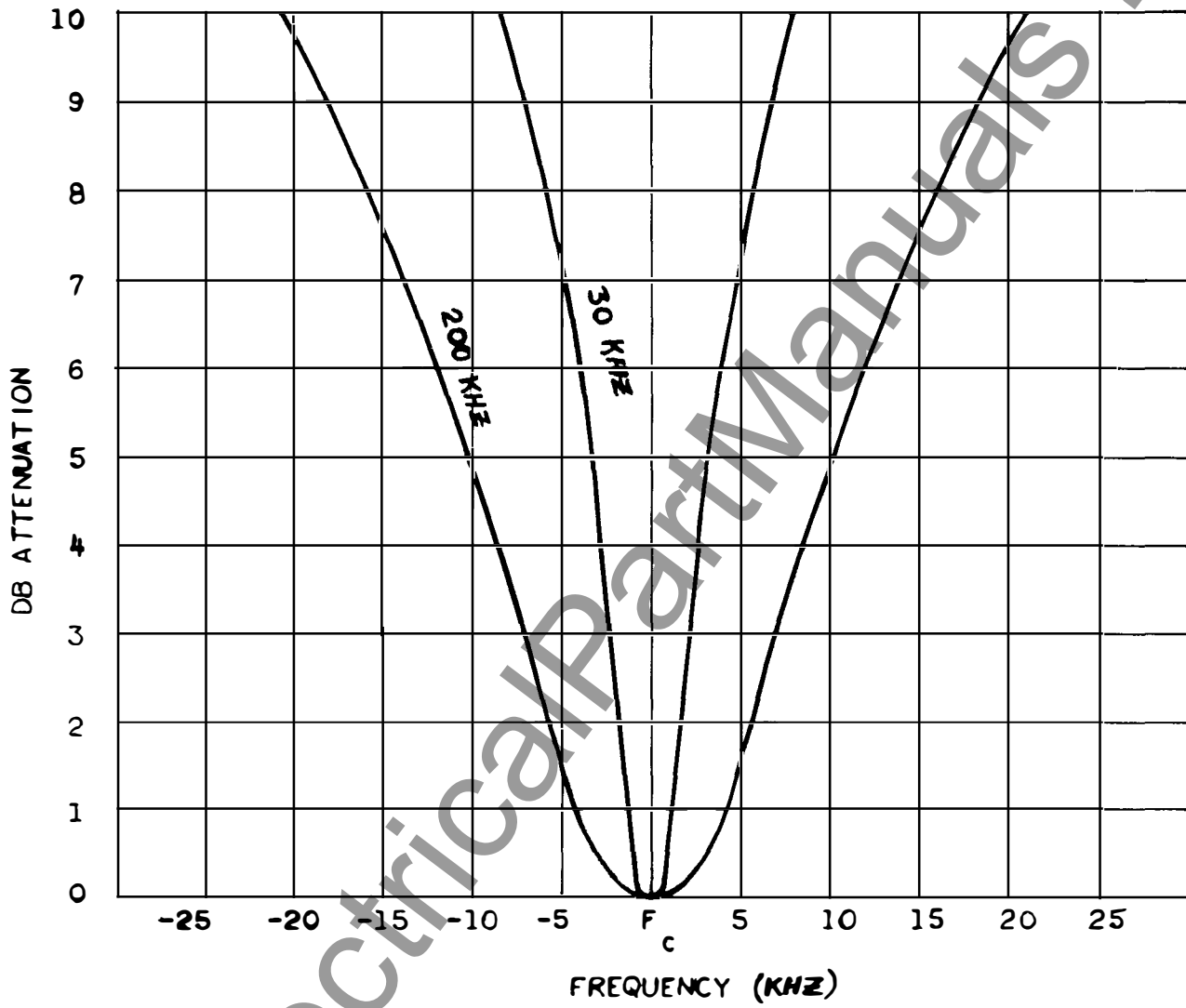

Fig. 10. Transmitter Output Filter Selectivity (Dwg. 377996)

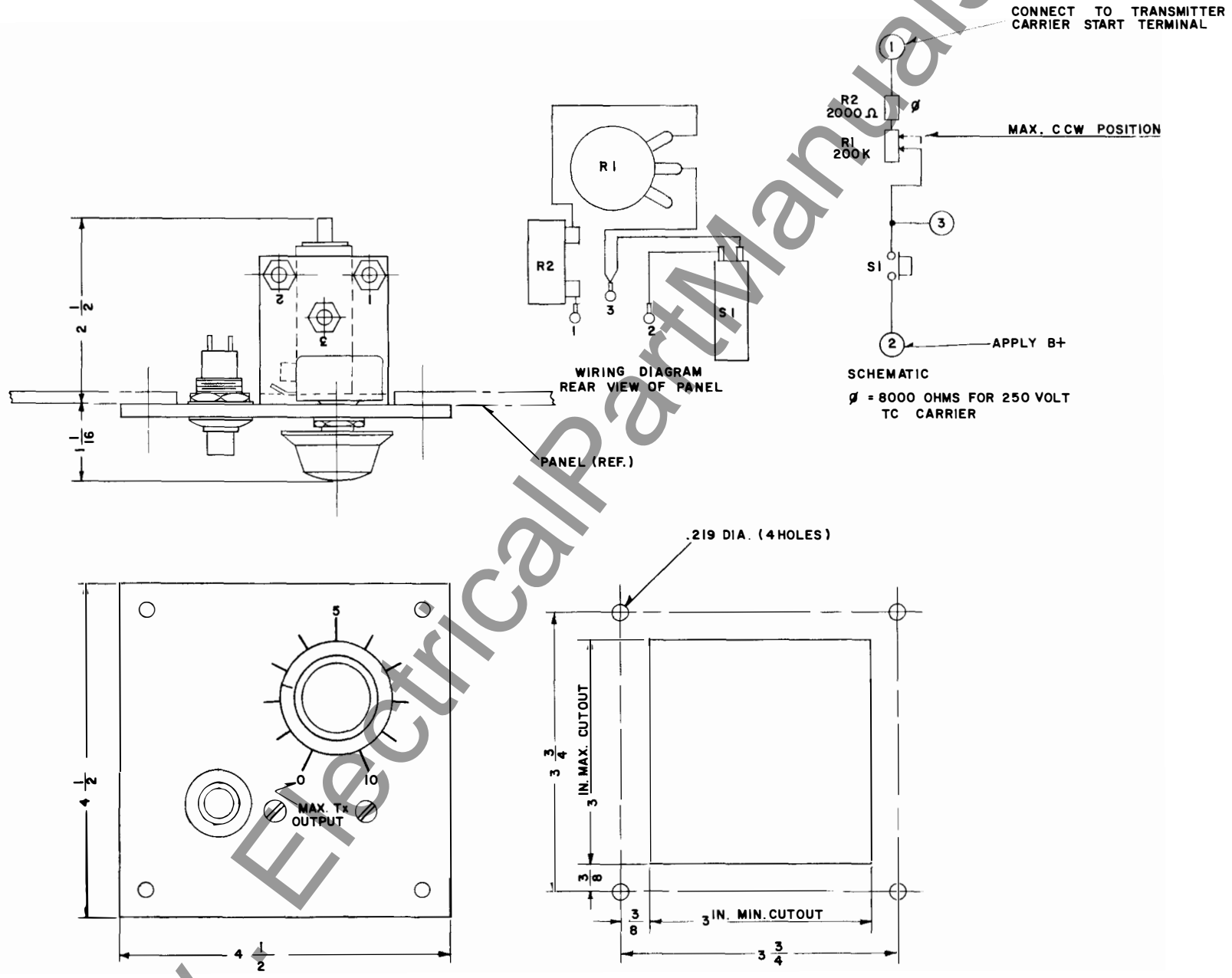

Fig. 11. Reserve Signal Detector Outline (Dwg. 329C703)

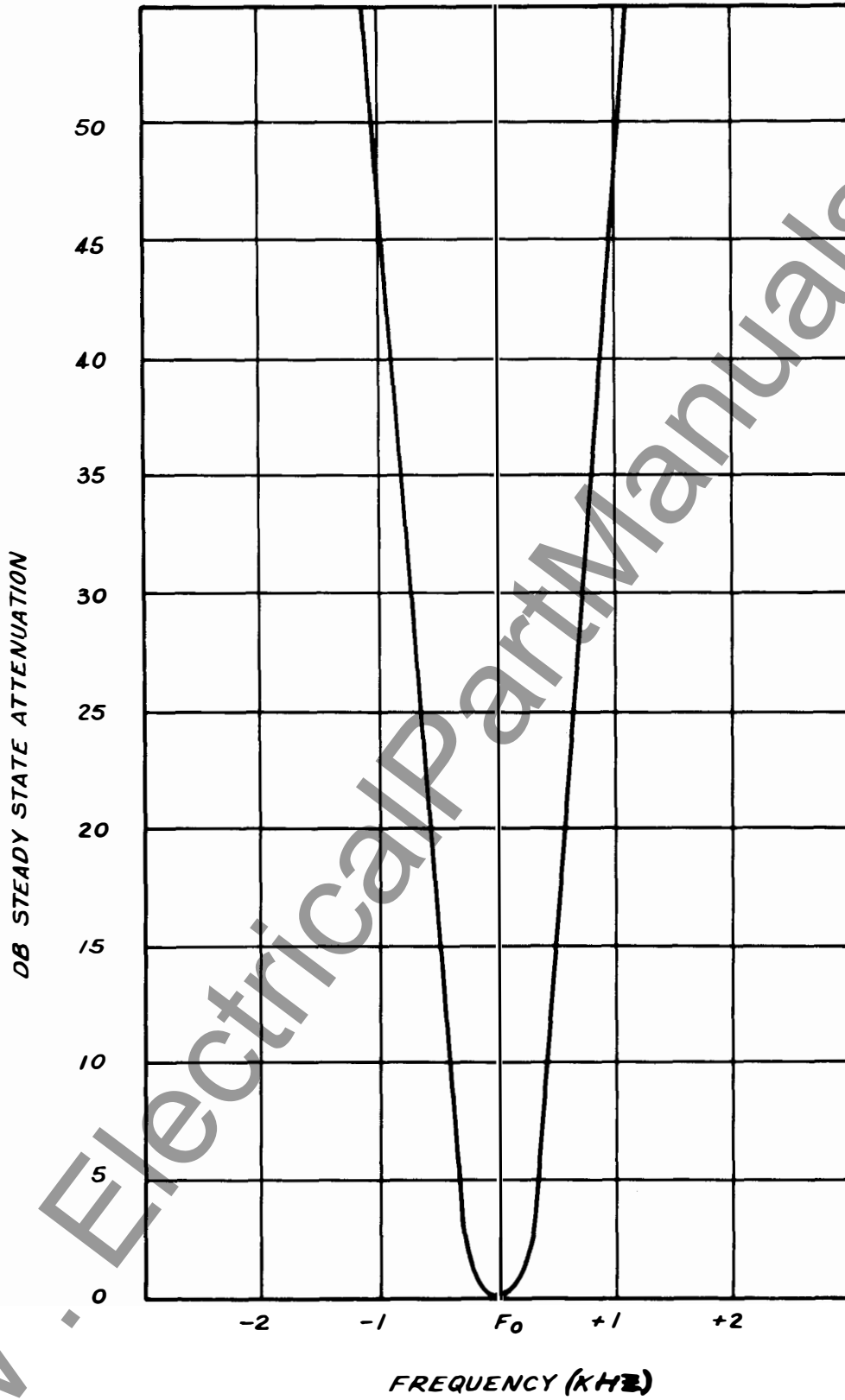
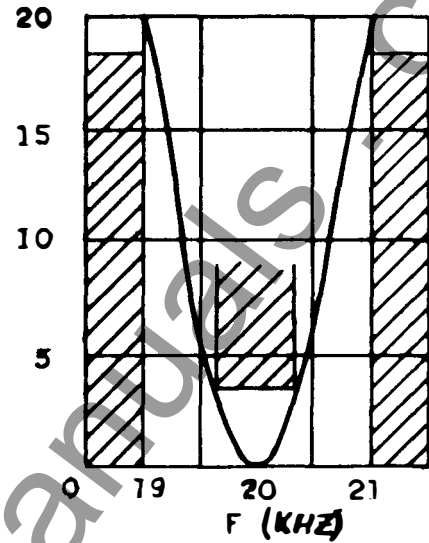
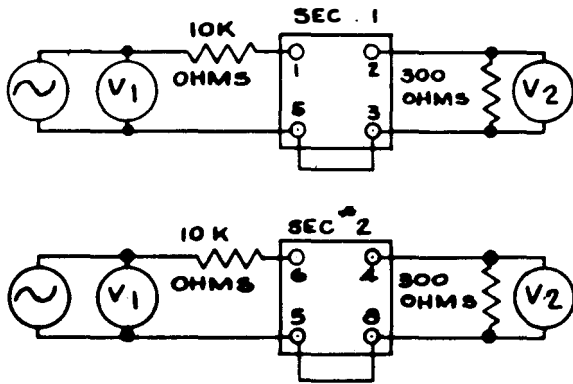

Fig. 12. Receiver Selectivity (Curve #377993)

IF FILTER TEST CIRCUIT



Each section of FL-2 requirement with typical selectivity curve. Insertion loss 26 DB max. including matching resistor.

FOR BOTH CURVES

$$DB = 20 \log \frac{V1}{V2}$$

RF FILTER TEST CIRCUIT

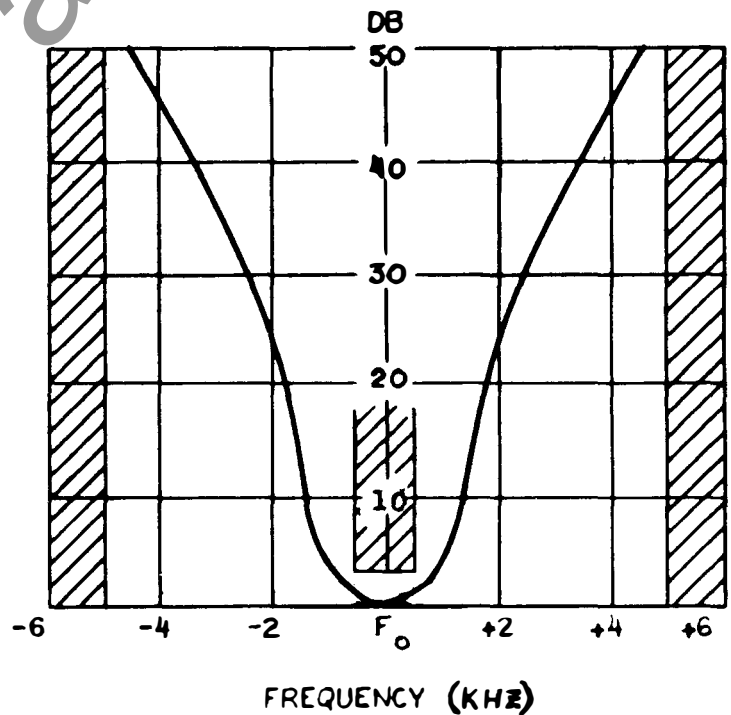
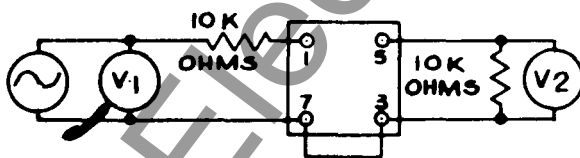

FL-1 requirement with typical selectivity curve at 120 KHZ. Insertion loss 22 DB max. including matching resistor.

* Fig. 13. Receiver Filter Limits (Curve #377995)

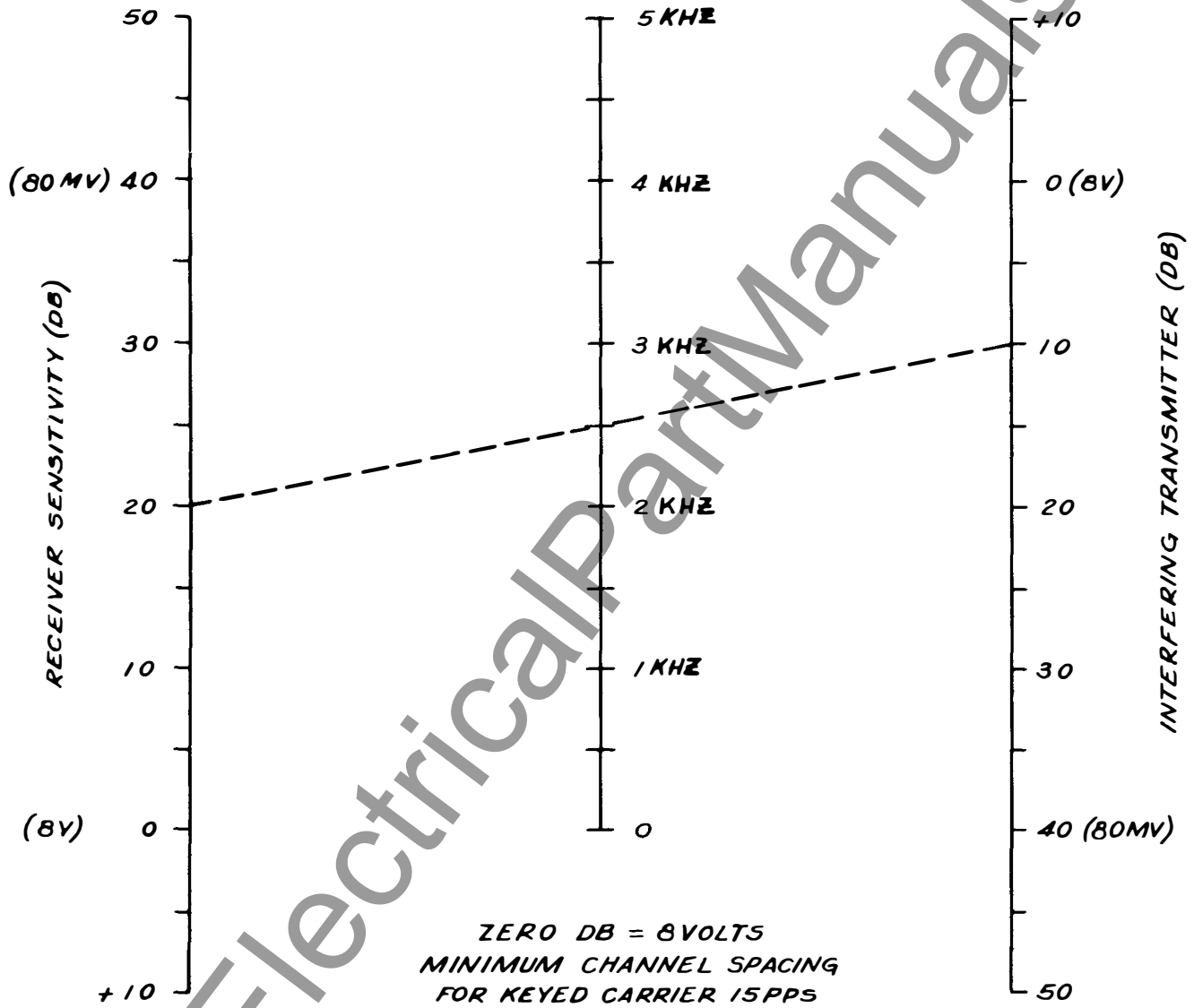
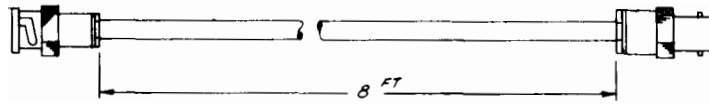
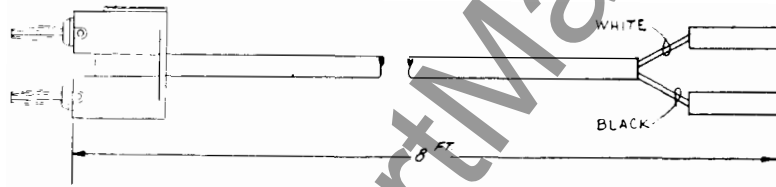

Fig. 14. Minimum Channel Spacing (Curve #377998)



Coaxial Lead... 756D346 G02



Output Lead... 756D346 G03

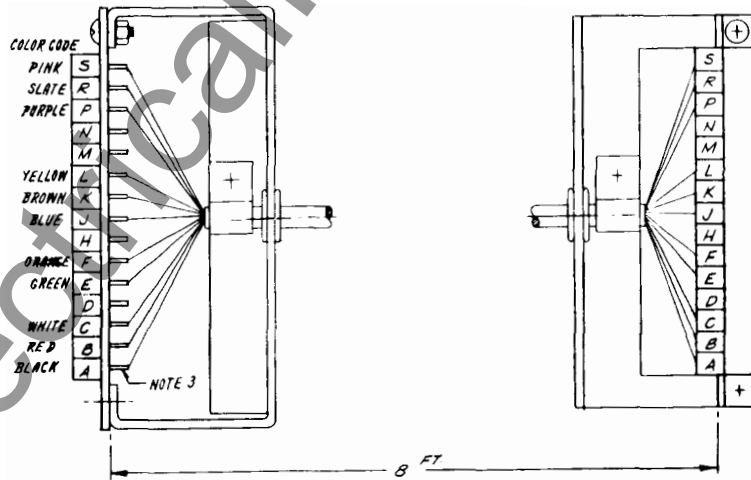

Main Harness... 756D346 G04

Fig. 15. Test Harness - (Complete Set)

www.ElectricalPartManuals.com

www.ElectricalPartManuals.com

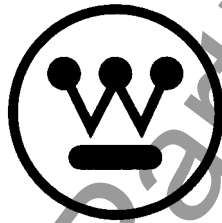

WESTINGHOUSE ELECTRIC CORPORATION
RELAY-INSTRUMENT DIVISION

NEWARK, N. J.

Printed in U.S.A.

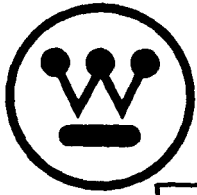

INSTALLATION • OPERATION • MAINTENANCE I N S T R U C T I O N S

TYPE KR CARRIER RELAYING TRANSMITTER-RECEIVER

Flexitest Case Mounted —with provision for rear-mounter Voice Adapter Accessories.	Style
KR Reserve Signal Detector	470D167 GO2
250 Volt Resistor Unit	330C191 H01
Test Harness (Complete Set)	756D346 G01
Coaxial Lead	756D346 G02
Output Lead	756D346 G03
Main Harness	756D346 G04

TABLE OF CONTENTS

Introduction	Page 2
Specifications	Page 2
Description	
General	Page 3
Mechanical	Page 3
Electrical	
Transmitter	Page 4
Receiver	Page 4
Transmitter Control Circuits	Page 5
Reserve Signal Detector	Page 5
Communications	Page 5
Relaying Control Circuits	Page 5
Installation	
General	Page 6
Connections	
External	Page 6
Internal	Page 7

Adjustments

Transmitter	Page 7
Receiver	Page 7
Reserve Signal Detector	Page 8
250-Volt Resistor Unit	Page 8
Frequency Change	Page 8

Maintenance	Page 9
Application	Page 13
Electrical Parts List	Page 14

LIST OF TABLES

Table

1 D-C Pin Jack Measurements with Reference to B-	Page 10
2 Transistor DC Measurements with Reference to B-	Page 11
3 D-C Bleeder Measurements with Reference to B-	Page 12
4 Typical RF Signal Measurements for Receiver	Page 12
5 Typical RF Signal Measurements for Transmitter	Page 13

LIST OF ILLUSTRATIONS

Figure		References
1	Outline – Flexitest Case	540D753
2	Internal Schematic	540D780
3	Relaying Control Circuits (HZ/HZM)	1-329C704
4	Relaying Control Circuits (K-Dar)	3-329C704
5	Relaying Control Circuits (GCX/GCY).....	2-329C704
6	Component Location.....	540D781
7	Supervisory Control Receiver Connection.....	223B498
8	Connections, 48-250 volts and Supervisory Control.....	407C971
9	Transmitter Output Filter Connections	149A420
10	Transmitter Output Filter Selectivity.....	C377996
11	Reserve Signal Detector – Outline and Schematic	329C703
12	Receiver Selectivity	C377993
13	Receiver Filter Limits	C377995
14	Minimum, Channel Spacing	C377998
15	Test Harness	756D346

CAUTION The voltages encountered in this equipment are dangerous to life. To be safe, disconnect the power source and close the grounding switch when servicing the equipment.

INTRODUCTION

The Type KR Relaying Transmitter-Receiver is designed for Distance Relaying, Telemetry, Supervisory Control and Sleet Detection. Facilities are provided for a plug-in type voice adapter. The basic design is for operation from 125-volt station batteries. However, the apparatus may also be operated from 48-volt or 250-volt station batteries by means of various internal connections. These various connections as well as most of the adjustments are made at the factory, although they can be changed in the field.

Although designed primarily for operation with Westinghouse protective relays, this apparatus may also be coordinated with other types of directional-distance relays and with most other contact keyed devices.

SPECIFICATIONS

Frequency Range.....	30-kHz to 200kHz
Channel Attenuation Rating	40-db
Transmitter Power Output	1.0 watt with a 125 V.D.C. supply. 0.5 watt with a 48-volt d-c supply.
Transmitter Harmonic Output	At least 46-db below fundamental.
Transmitter Output Impedance.....	Matches one 60-ohm coax. cable. (Suitable for 50-70 ohm cable.)
Transmitter Output Filter Selectivity	See Fig. 10
Transmitter and Receiver Oscillator and Frequency Stability	From -20°C to +55°C with simultaneous voltage variations from 105 to 140 VDC, the frequency remains within ±20Hz. *

Permissible Battery Voltage Ripple	7-1/2%
Ambient Temperature Range	- 20° C to + 55° C.
Receiver Maximum Sensitivity025 volts for 10 ma. output.
Receiver Selectivity	See Fig. 12
Receiver Signal-to-Noise Ratio Requirements	12-db
Minimum Channel Spacing	See Fig. 14
Power Input	115-ma at 48 VDC, 200-ma at 125 VDC, 1.28 amperes at 250 VDC.
Carrier On-Off Keying	Requires one pair of con- tacts capable of keying 8-ma DC at an open circuit voltage of 125 VDC.
Weight (With Flexitest Case)	Approximately 16-lbs.

CAUTION Refer application to Westinghouse when other transmitters are to be connected to the same coax cable as certain conditions may result in damage to the output transistors. such as potentiometers, jack, test points, crystals, transistors, etc. External connections and the Schematic Diagram are shown by Fig. 2. The numbered terminals shown as squares apply to the external terminals.

DESCRIPTION

Mechanical

This apparatus is supplied in a Flexitest case and may be either flush or projection mounted in order to match other switchboard equipment. The outline dimensions and also the drilling plan for flush and projection mounting are shown by Fig. 1. The majority of the parts are mounted on a printed circuit board. This board may be readily removed as follows:

1. Remove the two output plugs from the red and black jacks.
2. Disconnect the receiver input coaxial cable connector.
3. Loosen the two screws at the top of the board.
4. Loosen the two screws at the bottom of the board and pull them out as far as they will extend.
5. Pull board down to disengage the terminals and lift out.

The transmitter output filter may be removed by removing four mounting screws from the bottom of the case and disconnecting the coaxial cable.

Fig. 6. shows the location of major components

Provisions are made for plugging the Voice Adapter Unit in the rear of the relaying equipment. Octal socket marked X-4 on the rear of the set accommodates the adapter plug. A buckle type strap on each side of the adapter holds the unit in place after it has been plugged in. The normal projection for a rear mounted Voice Adapter is 3-inches beyond that of the relaying equipment. When the KR Relaying Unit is supplied with the adapter, a patch cord is available on separate order. This patch cord plugs into the telephone jacks on the adapter and provides an extension to a conveniently located terminal board.

The panel cutout information necessary for mounting the Reserve Signal Detector is shown by Fig. 11. This unit consists of a potentiometer and pushbutton switch mounted on a small panel, itself suitable for switchboard mounting.

For 250-volt operation, separate auxiliary resistors are required, as shown in Fig. 8.

Electrical

Transmitter

The transmitter is made of four main stages in -

cluding an oscillator, driver, power amplifier, and an output filter. In the oscillator, the crystal is operated as a resonant circuit between the collector of one transistor and the base of the other. The feedback is supplied through a capacitor from the collector of the second transistor to the base of the first transistor. The frequency is independent of voltage or temperature changes of the transistors. Thus the frequency stability is the stability of the crystal.

The input to the driver stage Q-10 is controlled by potentiometer, R-42 which also controls the transmitter power output. In HZM relaying CARRIER STOP provides about +40 volts for blocking. This is applied to Q-10 through T-6. Diode CR-5 prevents damage to the transistor when this positive voltage is applied to the collector. For CARRIER START (when in the blocked position) a small positive voltage is applied to the collector of Q-10 by means of bleeder resistors R-67 and R-68.

The power amplifier consists of two transistors Q-12 and Q-15, which are operated as class B amplifiers in push-pull. Resistors R-52 and R-55 are for stabilization.

The output transformer, T-7, matches coaxial cables of 50 to 70 ohms.

Resistor R-66 tends to keep the source impedance constant to permit proper tuning of the output filter.

The output filter consists of coils L-1 and L-2, capacitors C-19 through C-22. The filter is tunable, and is provided to attenuate harmonics and other spurious outputs. It should be noted that the filter contains no shunt elements, resulting in a reverse impedance free of "across the line" resonances.

Receiver

The receiver is a superheterodyne in order to obtain constant selectivity regardless of the channel frequency. (See Fig. 12) The major stages include an input filter, attenuator, oscillator, mixer, IF filters, IF amplifiers, detector and a D-C power output stage.

The receiver sensitivity is adjusted by means of the continuously variable input control R-1 and by connecting or disconnecting resistors R-73 and R-74 in the IF stages.

The receiver oscillator (Q-2 and Q-3) is basic-

ally the same as the transmitter oscillator. The frequency is 20-kHz above the incoming signal frequency.

The receiver channel frequency is determined by the input filter and the oscillator crystal. The frequency may be changed readily since both the filter and the crystal are plug-in components.

Mixing is accomplished by feeding the incoming signal to the emitter and the receiver oscillator signal to the base of the mixer Q-1. Mixer oscillator requirements are met through adjustment of potentiometer R-4. Injection into two separate elements, base and emitter, provides a circuit capable of handling greater signal level variations than one in which injection is made into only a single element such as the base.

This receiver uses an IF frequency of 20-kHz. The overall selectivity is determined primarily by the IF filter FL-2. Typical characteristics of this filter are shown in Fig. 13. The IF amplifier consists of transistors Q-4, Q-5 and Q-6.

The detector is a full wave bridge rectifier. This rectifier in conjunction with the IF amplifier Q-6, provides the necessary power to drive the D-C power output stage Q-7. The final output stage Q-7 will supply approximately 18 milliamperes to a standard 1700 ohms distance relay RRH coil and its associated 500 ohm alarm coil. It may also be used to drive other relay coils such as is shown by Fig. 7, Supervisory Control Connections.

Transmitter Control Circuits

In the standby condition, although the oscillator is running, the transmitter driver has no emitter bias which results in no output.

Positive voltage applied to terminal 15 supplies this bias through a voltage dividing network, and transmitter output results. The actual configuration of the network is a function of supply voltage and application (Relaying, Telemetry, etc.) and is discussed in the Adjustments section.

Output may be stopped in several ways. The method used with K-DAR relays is to remove the positive voltage applied to terminal 15. In the case of distance relaying with Westinghouse HZ/HZM relays, application of a positive voltage to terminal

18 will stop the transmitter output. Output may also be stopped by removal of negative battery from terminal 18.

Reserve Signal Detector

The Reserve Signal Detector is shown by Fig. 11. Effectively R-1 is a remote transmitter output control. This control is obtained through varying the driver Stage (Q-10) emitter bias, and is effective over a 25-db range of transmitter output. The detector is switched into service by S-1. By adjusting R-1 for a given receiver relay current at the far end of the channel, a relative measure of the channel attenuation may be obtained. This is discussed further in the section on Adjustments.

Communications

The transmitter output is reduced approximately 6-db when the Type KR voice adapter attachment is used. Relaying takes preference, and full output is obtained when full voltage is supplied to terminal 15.

Relaying Control Circuits

Figs. 3, 4 and 5 show simplified diagrams of the relaying control circuits.

1. K-DAR and GCY Relaying (Figs. 4 and 5)

The control of the carrier set is obtained through the CARRIER START and CARRIER STOP contacts. These contacts are shown in their normal standby condition.

The K-DAR or GCY relays operating from the voltage and current on the transmission line, detect and determine the direction of a line fault and thereby control the carrier transmitter and receiver.

The control of the carrier set is such as to start the transmission of carrier when fault power on the transmission line is flowing out of the line section being protected. Conversely, when fault power is flowing into this line section, the control is such as to block the transmitter and keep it from being turned on by secondary functions such as reserve signal detection and communication, should these functions be in use at the same time. Should carrier be received from the remote station, the hold coil and alarm coil will energize through transistor Q-7 in the receiver.

When carrier start operation occurs, the CARRIER

START contact opens applying a positive voltage (see Figs. 4 and 5) to terminal 15 of the carrier set. This puts a potential on the driver stage in the transmitter and also applies proper bias for the power amplifier.

When a carrier stop operation occurs, the CARRIER STOP contact closes, which removes B+ (terminal 15) from the driver and the power amplifier stages in the transmitter. CARRIER STOP, terminal 18, on the carrier set is permanently connected to terminal 14, for K-DAR and GCY relaying.

2. HZM Relaying (Fig. 3)

The control of the carrier set is effected by the CARRIER START and the CARRIER STOP contacts. These contacts are shown in their normal standby condition.

The HZ-HZM relays operating from the voltage and current on the transmission line, detect and determine the direction of a line fault and thereby control the carrier transmitter and receiver.

The control of the carrier set is such as to start the transmission of carrier when fault power on the transmission line is flowing out of the line section being protected. Conversely, when fault power is flowing into this line section, the control is such as to block the transmitter and keep it from being turned on by secondary functions such as reserve signal detection and communication, should these functions be in use at the same time. Should carrier now be received from the remote station, the hold coil and alarm coil will energize through transistor Q-7 in the receiver.

When carrier start operation occurs, the CARRIER START contact closes applying the full battery supply voltage to terminal 15 of the carrier set. This puts a potential on the driver stage in the transmitter and also applies proper bias for the power amplifier.

When a carrier stop operation occurs, the CARRIER STOP contact opens. This applies a positive voltage (see Fig. 3) to terminal 18 which blocks the driver stage and the power amplifier stage

It is possible under certain conditions that the signals from two transmitters, attempting to block a third receiver, would be of such amplitude, phase and frequency as to cause the RRH coil current to "pulsate". It would then be possible to have a false trip.

TYPE KR CARRIER SET

In the case of the KR set for relaying 3-terminal lines, the transmitter frequencies (to avoid this possibility of false trip) should be separated by 100 Hz. All receivers and one transmitter would be at the desired center frequency. One of the other transmitters would be 100 Hz above, the other 100 Hz below this center frequency.

INSTALLATION

General

Upon receipt of a unit, whether shipped separately or in an assembly, an immediate inspection should be made. Carefully check for damage or shortages.

For necessary clearances and mounting dimensions, see the following illustrations:

- Flexitest Case Mounting..... Fig. 1
- Reserve Signal Detector Fig. 11

Connections

External

The external connections will vary slightly depending on the application, but in general will be as follows: (Refer to the Schematic Diagram, Fig. 2.)

- Terminals 11..... Ground
- 12..... Coaxial Cable

- 13 and 19 Supervisory Preference Contacts
- 14..... B- "CARRIER STOP" return
- 15..... Battery positive through carrier start contacts
- 16..... Battery positive for alarm cutoff (used with communication)
- 17..... B-
- 18..... Carrier Stop for HZM Relaying
- 19..... B+
- 20..... Relay Coil

CAUTION If the transmitter output load is removed while the transmitter is energized, the transistors in the power amplifier will be permanently damaged. A dummy load should be connected to the transmitter output if the coax is disconnected and the transmitter is to be energized.

When tuning line coupling equipment, short the coaxial cable to ground before changing taps on the Line Tuner or matching transformer.

Internal

Necessary internal connections are generally made at the factory, to customer order, before apparatus shipment. For reference purposes, these are outlined in the following tabulation. Check the proper bleeder resistors before applying voltage to the equipment.

OPERATION

BLEEDER RESISTORS IN THE CIRCUIT

- 48-Volt K-DAR, HZM, and GCY Relaying, Telemetry, and Supervisory
- 125-Volt K-DAR and GCY Relaying
- 125-Volt HZM Relaying, Telemetry, and Supervisory
- 250-Volt K-DAR and GCY Relaying
- 250-Volt HZM Relaying, Telemetry, and Supervisory

at the specified channel frequency before shipment. Final adjustments must be made in the field and are described in the following paragraphs. Fig. 6 shows the locations of the various controls.

Transmitter

1. Disconnect the coaxial cable and replace with a 50, 60, or 70 ohm non-inductive resistor depending on the characteristic impedance of the cable used.
2. Fig. 9 shows typical output filter connections for various frequency ranges. In some cases it may be necessary to use either a higher or lower range to tune the filter to resonance.
3. Insert fuses F- 1 and F- 2 to apply power to the apparatus.

Adjustments

This apparatus is generally tuned to and tested

4. Connect an A-C Vacuum Tube Voltmeter (VTVM) across the non-inductive load.

R-47 and R-48

R-45, R-47 and R-48

R-41, R-45, R-47 and R-48

R-45, R-47 and R-48

R-39, R-40, R-41, R-45, R-47 and R-48

5. Unblock the transmitter by closing the CARRIER TEST SWITCH. An alternative is to jumper battery positive to terminal 15.

6. Beginning with the output control R-42 at the maximum counterclockwise position, advance it clockwise until a reading appears on the VTVM. Tune capacitor C-19 for a maximum voltmeter reading.

7. While increasing R-42, tune the output filter for maximum output until the output across the resistor is approximately 8 volts. (Approximately 5.5-volts when operating from 48-volt station battery.)

8. Open the test switch and reconnect the coaxial cable.

Receiver

1. The oscillator output control R-4 is pre-set at the factory. However, should any of the oscillator components be changed (including the transistors and the crystal) R-4 will require adjustment.

a. Connect an A-C VTVM to jacks J-3 and J-4.

b. Adjust R-4 for a 0.3 volt reading on the meter.

2. The unit is shipped to have a gain of approximately 250 millivolts (to produce 10 ma relay current) with input control R-1 in maximum clockwise position. About 10-db additional gain or 80 millivolt sensitivity can be obtained by clipping out resistor R-74, which is connected to the base of Q-4 and the B+ supply for the IF. A further 10-db gain or additional 25 millivolt sensitivity can be obtained by also clipping out resistor R-73, which is connected to the base of Q-5 and the B+ supply for the IF. Resistor R-71 and R72 have been selected at the factory to provide an overall gain of approximately 25 millivolts with R73 and R74 removed.

a. Sensitivity Adjustment for Noise

If the maximum on-frequency noise level is known or can be measured, the receiver can be adjusted for this level. Disconnect the coaxial cable and connect a 60-ohm non-inductive resistor and a VTVM across terminals 11 and 12. Energize the transmitter and output control R-42 for the same output as the maximum noise. Then adjust the receiver input control R-1 to obtain 1-ma output current. If it is impossible to obtain 1-ma output current with control R-1 in the maximum clockwise position, then clip out resistor R-74, which is connected to the base of Q-4. If the gain is still insufficient, clip out resistor R-73, which is connected to the base of Q-5. After completing the adjustment of R-1, restore the transmitter to full output.

b. Sensitivity Adjustment for Remote Signal

When the maximum on-frequency noise is unknown and cannot be conveniently measured, the receiver may be adjusted for the remote signal. First determine the channel attenuation using a Sierra voltmeter or some other convenient method. Disconnect the coaxial cable and connect a 60-ohm non-inductive resistor and a VTVM across terminals 11 and 12. Add 15-db to the channel attenuation. This compensates for average variations such as channel and voltage variations. For example, if the channel attenuation is 5-db, add this to the 15-db making a total of 20-db. Taking this from 8 volts output of the transmitter, the receiver should then be set for a sensitivity of 0.8 volts. To do this, adjust the transmitter output control R-42 for 0.8 volts and then adjust the receiver input control so as to obtain 10-ma output current. If it is impossible to obtain 10-ma output current with control R-1 in the maximum clockwise position, clip out resistor R-74, which is connected to the base of Q-4. If the gain is still insufficient, clip out resistor R-73, which is connected to the base of Q-5. After completing the adjustment of R-1, restore the transmitter to full output.

It must be kept in mind that the two preceding adjustment procedures are to be used as a guide and will cover the majority of cases; however, cases may arise where conditions change. For example, if the adjustment is made per part a., the noise may increase due to various reasons such as bad insulators, which would require adjusting the receiver to be less sensitive. In the adjustment of part b., the attenuation may increase due to sleet or line switching,

which would necessitate increasing the sensitivity of the receiver.

Reserve Signal Detector

Due to different types of operation and supply voltages, it is not practical to have a calibrated dial for this unit. However, calibration may be made at installation by recording transmitter output (either in db or volts) at various knob settings of the detector unit. Then, by adjusting the knob so as to obtain 10 milliamperes relay current at a remote receiver, any increase or decrease in line attenuation may be noted as the difference between the original setting, and the setting required to obtain the given 10 milliamperes.

250-Volt Resistor Unit

With the apparatus energized, adjust R-4 in the 250-volt resistor unit so as to obtain 125-volts at terminals 17 (B-) and 19 (B+) on the relaying set.

Frequency Change

If the frequency is changed in the field, it is necessary to change the input filter FL-1 to the desired channel frequency. This filter is of the plug-in type and may be removed by unsnapping the clamp and pulling the filter out. The transmitter oscillator crystal Y-2 must be changed to the desired channel frequency. The receiver oscillator crystal Y-1 must be changed to the desired channel frequency plus 20 kHz. Figure 9 shows the connections for the transmitter output filter. It is necessary to unsolder the existing connections and make the new connections per the chart. After completing the preceding, the tuning procedure as described under Adjustments for transmitter and receiver should then be followed.

Note also that capacitors C2 and C9 in the transmitter and receiver crystal oscillator circuits, respectively, may have to be changed. For frequencies below 110 kHz, these capacitors are 270 mmf. each. For frequencies of 110 kHz and above, the capacitors are 140 mmf. each.

CAUTION Turn power OFF before removing filters or transistors, as high transient currents may cause permanent damage to the transistors.

MAINTENANCE

Voltage values should be recorded after adjustment in order to establish reference values which will be useful when checking the apparatus. The readings

will remain fairly constant over an indefinite period unless a failure occurs. However, if transistors are changed, there may be considerable difference in these readings without the overall performance being affected.

Typical voltage and current values are given as follows. Voltages should be measured with VTVM. Readings may vary as much as $\pm 20\%$.

In the following paragraphs, the transmitter may be unblocked (transmitting) by closing the CARRIER START circuit in the case of HZM relaying, and by opening the CARRIER START circuit in the case of K-DAR and GCY relaying.

1. For D-C pin jack measurements with reference to B-, refer to Table 1.

2. For transistor D-C measurements with reference to B-, refer to Table 2.

3. For D-C bleeder measurements with reference to B-, refer to Table 3.

4. For typical RF signal measurements for receiver, refer to Table 4.

5. For typical RF signal measurements for transmitter, refer to Table 5.

6. Removal of Printed Circuit Board from Flexitest Case.

To remove the printed circuit board, unplug J-15 and J-16 located near the output filter. Loosen the two screws inside the case near the top. Loosen the slotted thumb screws at the lower end of the board and pull these screws out as far as they will extend. Also remove the receiver coaxial cable plug.

Pull board down so as to disengage the terminals, and lift out.

7. Removal of the Output Filter

After the printed board has been removed, remove the screws on the outside of the case at the bottom. Lift out filter and disconnect the coaxial cable.

8. Receiver Filters

Fig. 13 shows typical receiver selectivity curves both RF and IF. If the filters are checked in a test

setup, it is necessary to use an accurate signal generator or preferably a signal generator and a frequency counter.

9. Minimum Test Equipment for Installation

- a. Milliammeter 0-25 ma DC.
- b. 60-ohm 5-watt non-inductive resistor.
- c. A-C Vacuum Tube Voltmeter (VTVM). Voltage range 0.003 to 30 volts, frequency range 60 Hz to 230-kHz, input impedance 7.5 megohms.
- d. D-C Vacuum Tube Voltmeter (VTVM)

Voltage Range: 0.15 to 300 volts
Input Impedance: 7.5 megohms

10. Desirable Test Equipment for Apparatus Maintenance

- a. All items listed in Sections 8 and 9.
 - b. Signal Generator
- Output Voltage: up to 8 volts
Frequency Range: 20-kHz. to 230-kHz.
- c. Oscilloscope
 - d. Ohmmeter
 - e. Capacitor checker
 - f. Test harness (See Fig. 15)

APPLICATION

1. Receiver Selectivity (Fig. 12)

This shows a typical curve of the overall selectivity of the receiver under steady state conditions.

2. Transmitter Output Selectivity (Fig. 10)

Typical curves are shown so that approximate bandwidths for keying purposes can be determined for any carrier frequency between 30-kHz and 200-kHz.

3. Minimum Channel Spacing (Fig. 14)

This is a graph from which minimum channel spacing can be obtained provided the signal strength of the interfering transmitter and the sensitivity setting of the receiver are known. These can be obtained from calculations or by measurements.

For example, if the interfering transmitter voltage is measured (at the receiver) and found to be 2.5 volts, this would be 10-db down from 8 volts. This point can be located on the right hand column of the graph. Then, if the receiver sensitivity were set to operate on 0.8 volts or 20-db, this point would be located on the left hand column. A line could then be drawn through the two points as shown by the dotted line. The intersection of this line with the center line indicates the minimum channel spacing. In this case if the interfering signal is being keyed on-off, at 15 pps, the minimum spacing would be 2.5-kHz.

4. Supervisory Control Connections (Fig. 7)

When supervisory control is used with relaying, the supervisory control relay coil is connected in series with the RRH coil in place of the alarm relay. When supervisory control is used alone, a 1200-ohm resistor R3 is connected in series with the control relay coil by removing the jumper across R3, as shown in Fig. 7. In order to maintain proper mark space ratio, the relay bias current is adjusted for 9 milliamperes as indicated.

The receiver RF filter and the IF filter limits are shown on Fig. 15. Both filters are of the plug-in type and the test circuits with pin connections are shown at the top of each curve. The IF filter is divided into two separate sections. The selectivity shown is for each section, and the pin connections for each section are also shown in the test circuit sketch.

TABLE 1

D-C PIN JACK MEASUREMENTS WITH REFERENCE TO B-

Description	Jack	CONDITION A Tx-Blocked †† Rx-No Signal		CONDITION B Tx-Blocked Rx-With Signal		CONDITION C Tx-Unblocked Rx-No Signal	
		129 VDC	51 VDC	129 VDC	51 VDC	129 VDC	51 VDC
RF Input	J-2	0	0	0.3 V	0.3 V		
DC Q-1 Base	J-3	20 V	20 V	20 V	20 V		
DC R _x B+	J-4	20 V	20 V	20 V	20 V		
DC R _x Osc	J-5	7 V	7 V	7 V	7 V		
DC Q-5 Base	J-6	20 V	20 V	20 V	20 V		
B-	J-7						
DC-P1-E	J-8	110 V	32 V	110 V	32 V	110 V	32 V
DC-Q-7 Base	J-9	69 V	0 V	78 V	2.3 V	66 V	0.3 V
DC Q-7 Emit	J-10	70 V	1.0 V	78 V	1.4 V	66 V	1.0 V
DC T _x Osc	J-11	7 V	7 V	7 V	7 V	7 V	7 V
B+	J-12	129 V	51 V	129 V	51 V	129 V	51 V
DC Q-10 Base	J-13					18 V	18 V
DC Q-10 Emit	J-14					18 V	18 V
RF ma out	J-15					130 ma	130 ma
DC ma RRH and ALARM				18 ma	18 ma		

†† Tx = transmitter, Rx = receiver

TABLE 2

TYPICAL TRANSISTOR DC MEASUREMENTS WITH REFERENCE TO B-

Transistor	Condition A Tx-Blocked Rx-No Signal (Volts)			Condition B Tx-Blocked Rx-With Signal (Volts)			Condition C Tx-Unblocked Rx-No Signal (Volts)		
	E†	B†	C†	E†	B†	C†	E†	B†	C†
Q-1	20.0	20.0	0.38	20.0	20.0	0.4			
Q-2	7	7.2	1.8	7	7.2	1.8			
Q-3	6.2	8.0	2	6.2	8	2.0			
Q-4	20.0	20.0	2.6	20.0	20.0	2.8			
Q-5	20.0	20.0	2.6	20.0	20.0	2.8			
Q-6									
129 VDC	110	110	129	115	114	129			
51 VDC	32	32	51	32	32	51			
Q-7									
129 VDC	70	68	129	78	80	86			
51 VDC	1.0	0	51	1.4	2.2	7.0			
Q-8	6.2	8	2	6.2	8	2	6.2	8	2
Q-9	7	7.2	1.8	7	7.2	1.8	7	7.2	1.8
Q-10††							18	18	0.4
Q-12††							0.27	0.20	50
Q-15††							0.27	0.20	50

† E-Emitter; B-Base; C-Collector.

†† With respect to term F on printed board.

TABLE 3

D-C BLEEDER MEASUREMENTS WITH REFERENCE TO B-

Measurement	129 VDC			51 VDC		
	A†	B†	C†	A†	B†	C†
Junction R-61 and R-62 (J-8)	110V	110V	110V	32V	32V	32V
Junction R-61 and R-27 (J-10)	70V	78V	66V	1.0V	1.4V	1.0V
Junction R-27 and R-60 (P1-P)	69V	77V	65V	0	0	0
Junction CR-8 and R-64 (P1-K)	58V	58V	58V	51V	51V	51V
Junction R-48 and R-47 (J-14)	—	—	18V	—	—	18V
Junction R-45 and R-47 (TP-9)	—	—	45V	—	—	51V
Junction R-45 and R-41 (TP-8)	—	—	98V	—	—	51V

†Conditions: A — Tx-Blocked, Rx-No Signal; B — Tx-Blocked, Rx-With Signal; C — Tx-Unblocked, Rx-No Signal.

TABLE 4
TYPICAL RF SIGNAL MEASUREMENTS FOR RECEIVER
(Made with 0.1 Volt at Terminal 5 of FL1)

Check Point	25 MV Sensitivity (Volts)	80 MV Sensitivity (Volts)	250 MV Sensitivity (Volts)
With Receiver Crystal Out			
FL1-5 to Gnd.	0.1	0.1	0.1
T1-1 to Gnd.	0.1	0.1	0.1
Q1-E to Gnd.	0.05	0.05	0.05
Q1-C to Gnd.	0.07	0.07	0.07
T3-1 to Gnd.	0.07	0.07	0.07
Q4-C to Gnd.	0.07	0.07	0.07
With Receiver Crystal In			
Q4-C to Gnd.	0.5	0.5	0.25
J6 to Gnd.	0.15	0.1	0.08
Q5-C to Gnd.	7.0	1.7	0.8
Q6-B to Gnd.	2.0	0.5	0.4
Q6-C to Gnd.	13.0	10.0	8.0
T4-1 to Gnd.	13.0	10.0	8.0
T4-3 to T4-4	4.5	3.5	2.5
J9 to J10 (DC)	0.74	0.75	0.65

TABLE 5

TYPICAL RF SIGNAL MEASUREMENTS FOR TRANSMITTER

CHECK POINT	VOLTS
T5-1 to Gnd.	5.5
T5-3 to Gnd.	1.0
J13 to Gnd.	0.085
Q10-C to Gnd.	6.0
T6-2 to Gnd.	6.0
Q12-B to Gnd.	0.8
Q15-B to Gnd.	0.8
Q12-C to Gnd.	38.0
Q15-C to Gnd.	38.0
T7-5 to Gnd.	9.8
Output to Gnd.	8.0

ELECTRICAL PARTS LIST

CIRCUIT SYMBOL	FUNCTION	DESCRIPTION	MANUFACTURER'S DESIGNATION
<u>CAPACITORS</u>			
C-1	Rcvr. Bleeder	2.0 μf , $\pm 20\%$, 200 VDC, Paper	330C567 H11
†C-2	Rcvr. Osc. Feedback	140/270 μf , $\pm 20\%$, 500 VDC, Mica	330C566H43 * or 330C566H57
C-3	Rcvr. Osc. Bleeder Bypass	0.02 μf , MRC, 600 VDC, Disc	330C569 H47
C-5	Q-6 Emitter Bypass	1.0 μf , $\pm 20\%$, 200 VDC Paper	330C567 H09
C-6	Rcvr. Rectifier Bypass	Same as C-5	
C-7	B- to B+ Bypass	2 μf , $\pm 10\%$, 600 VDC, Paper	14C9400 H18
C-8	B- to GND	1.0 μf , $\pm 10\%$, 1000 VDC, Paper	14C9400 H17
†C-9	Xmtr. Osc. Feedback	Same as C-2	
C-10	Xmtr. Osc.	Same as C-3	
C-11	Key Filter	0.1 μf , $\pm 20\%$, 200 VDC, Paper	330C567 H02
C-12	Q-10 Emitter Bypass	0.25 μf , $\pm 20\%$, 200 VDC, Paper	330C567 H05
C-13	Q-10 Bleeder Bypass	Same as C-12	
C-14	PA Base Bypass	Same as C-12	

† Note: 140 μf for osc. freq. 110-kHz and above.
270 μf for osc. freq. below 110-kHz.

CIRCUIT SYMBOL	FUNCTION	DESCRIPTION	MANUFACTURER'S DESIGNATION
CAPACITORS (Concluded)			
C-18	PA Bleeder	0.5 μf , $\pm 20\%$, Paper	330C567 H06
C-19	Output Filter Tuning	500 μf , Variable, Air	328C092 H01
C-20	Output Filter	390 μf , $\pm 5\%$, 2500 VDC, Mica	330C561 H15
C-21	Output Filter	680 μf , $\pm 5\%$, 2500 VDC, Mica	330C561 H21
C-22	Output Filter	1200 μf , $\pm 5\%$, 2500 VDC, Mica	330C561 H27
C-24	FL-2 Decoupling	Same as C-12	
C-25	Q-7 Emitter	12 mfd, $\pm 20\%$, 200 VDC	187A177 H01
C-26	Q-7 Base Bypass	.01 mfd, $\pm 10\%$, 100 VDC	763A219 H15
D I O D E S			
CR-1	Bridge Rectifier	General Purpose, 1N63	584C433 H02
CR-2	Bridge Rectifier	Same as CR-1	
CR-3	Bridge Rectifier	Same as CR-1	
CR-4	Bridge Rectifier	Same as CR-1	
CR-5	Q-10 Collector	Same as CR-1	
CR-6	Q-7 Base-Emitter	Type 1N457A	184A855 H07
CR-7	Voltage Regulator	Type 1N3686	185A212 H06
CR-8	Voltage Regulator	Type 1N1369	584C434 H05
CR-9	Q-7 Collector	Type 1N3811	185A089 H08
CR-10	Q-10 Emitter	Type 1N3028A	188A302 H14
CR-11	Voltage Regulator	Type 1N3024B	188A302 H12

ELECTRICAL PARTS LIST

CIRCUIT SYMBOL	FUNCTION	DESCRIPTION	MANUFACTURER'S DESIGNATION
<u>FUSE HOLDERS</u>			
FH-1	B-	For Type 3AGC Fuses	584C271 H02
FH-2	B+	Same as FH-1	
<u>FUSES</u>			
F-1	B-	3AGC 3/4 amp.	S#330C691 H12
F-2	B+	Same as F-1	
<u>FILTERS</u>			
FL-1	Rcvr. RF Bandpass	30 to 200 kHz Freq. to be specified by customer	
FL-2	Rcvr. IF Bandpass	20-kHz Fixed Freq.	* 541D086G01
<u>CONNECTORS</u>			
J-1	Printed Circuit	Printed Circuit Female Plug	54-B-7125 H03
J-2	RF Input	UG-185-U	584C292 H07
J-3	Rcvr. Osc. Output	Terminal Studs	330C592 H01
J-4	Rcvr. Mixer-Amp Supply	Same as J-3	
J-5	Rcvr. Osc. Supply	Same as J-3	
J-6	Q-5 Base	Same as J-3	
J-7	B-	Same as J-3	
J-8	Q-6 Supply	Same as J-3	

ELECTRICAL PARTS LIST

CIRCUIT SYMBOL	FUNCTION	DESCRIPTION	MANUFACTURER'S DESIGNATION
<u>CONNECTORS (Concluded)</u>			
J-9	Q-7 Base	Same as J-3	
J-10	Q-7 Emitter	Same as J-3	
J-11	Xmtr. Osc. Supply	Same as J-3	
J-12	B+	Same as J-3	
J-13	Xmtr. Osc. Output	Same as J-3	
J-14	Q-10 Supply	Same as J-3	
J-15	Output Filter	Banana Tip Red	328C093 H01
J-16	Output Filter GND	Banana Tip Black	328C093 H02
P-1	Printed Circuit	Printed Circuit Male Plug	54-B-7126 H03
<u>INDUCTORS</u>			
L-1	Core and Coil Assembly	11 MH Total – 6 MH Tap (Part of FL-3)	329C450
L-2	Core and Coil Assembly	2.5 MH (Part of FL-3)	329C449
L-3	RF Choke	1.0 MH, 300 ma	R-300
L-4	RF Choke	Same as L-3	
<u>TRANSISTORS</u>			
Q-1	Rcvr. Mixer	Type 2N525	184A638H13
Q-2	Rcvr. Osc.	Type 2N414	184A638H14

ELECTRICAL PARTS LIST

CIRCUIT SYMBOL	FUNCTION	DESCRIPTION	MANUFACTURER'S DESIGNATION
<u>TRANSISTORS (Concluded)</u>			
Q-3	Rcvr. Osc.	Same as Q-2	
Q-4	Rcvr. IF	Same as Q-1	
Q-5	Rcvr. IF	Same as Q-1	
Q-6	Rcvr. IF	Type 2N657	184A638H15
Q-7	Rcvr. Output	Type 2N698	762A585H02
Q-8	Xmtr. Osc.	Same as Q-2	
Q-9	Xmtr. Osc.	Same as Q-2	
Q-10	Xmtr. Amp.	Same as Q-1	
Q-12	Xmtr. PA	Type 2N498 or Type 2N657	184A638H07 184A638H15
Q-15	Xmtr. PA	Same as Q-12	
<u>RESISTORS</u>			
R-1	Rec. Input	25 K, $\pm 20\%$, 1/4 W, Pot.	584C276 H23
R-2	Filter Matching	10 K, $\pm 10\%$, 1/2 W	330C595 H37
R-3	Filter Load	Same as R-2	
R-4	Rcvr. Osc.	1 K, $\pm 20\%$, 1/4 W, Pot.	584C276 H19
R-5	Rcvr. Voltage Divider	6.2 K, $\pm 5\%$, 1 W	330C666 H68
R-6	Q-2 Collector	1.2 K, $\pm 5\%$, 1/2 W	330C664 H51
R-8	Rcvr. Voltage Divider	15K $\pm 1\%$, 3W	763A126H08
R-9	Rcvr. Voltage Divider	Same as R-8	

ELECTRICAL PARTS LIST

CIRCUIT SYMBOL	FUNCTION	DESCRIPTION	MANUFACTURER'S DESIGNATION
		<u>RESISTORS (Continued)</u>	
R-10	Q-2 Base	Same as R-2	
R-11	Q-2 Base	100 K, $\pm 5\%$, 1/2 W	330C665 H05
R-12	Q-3 Collector	Same as R-6	
R-13	Q-3 Emitter	390 Ohms, $\pm 5\%$, 1/2 W	330C664 H39
R-14	Q-3 Base	Same as R-2	
R-15	Q-3 Base	Same as R-11	
R-16	Rcvr. Osc. Bleeder	2.2 K, $\pm 10\%$, 1/2 W	330C595 H41
R-17	Rcvr. Osc. Bleeder	18 K, $\pm 10\%$, 2 W	330C597 H40
R-18	Rcvr. Osc.	9.1 K, $\pm 5\%$, 1/2 W	330C664 H72
R-19	Q-4 Bias	100 Ohms, $\pm 5\%$, 1/2 W	330C664 H25
R-20	Q-4 Bias	Same as R-2	
R-21	Q-5 Bias	150 Ohms, $\pm 5\%$, 1/2W	330C664 H29
R-22	Q-5 Bias	Same as R-2	
R-23	Q-6 Bias	330 Ohms, $\pm 5\%$, 1/2 W	330C664 H37
R-24	Q-6 Bias	Same as R-2	
R-25	Q-6 Emitter	Same as R-19	
R-26	Q-7 Base	Same as R-6	
R-27	Q-7 Bias	20 Ohms, $\pm 5\%$, 1/2 W	330C664 H08
R-28	Xmtr. Osc. Bleeder	Same as R-18	
R-29	Xmtr. Osc. Bleeder	Same as R-17	
R-30	Xmtr. Osc. Bleeder	Same as R-16	

ELECTRICAL PARTS LIST

CIRCUIT SYMBOL	FUNCTION	DESCRIPTION	MANUFACTURER'S DESIGNATION
		<u>RESISTORS (Continued)</u>	
R-31	Q-8 Base	Same as R-11	
R-32	Q-8 Base	Same as R-2	
R-33	Q-8 Emitter	Same as R-13	
R-34	Q-8 Collector	Same as R-6	
R-35	Q-9 Base	Same as R-11	
R-36	Q-9 Base	Same as R-2	
R-37	Q-9 Collector	Same as R-6	
R-38	Key Filter	Same as R-23	
R-39	Buffer Voltage Divider	36 K, $\pm 5\%$, 2 W	330C668 H86
R-40	Buffer Voltage Divider	Same as R-39	
R-41	Buffer Voltage Divider	Same as R-2	
R-42	Xmtr. Osc. Output	Same as R-4	
R-43	Q-10 Bias	Same as R-23	
R-44	Q-10 Bias	33 K, $\pm 5\%$, 1/2 W	330C664 H85
R-45	Buffer Voltage Divider	15 K, $\pm 10\%$, 1 W	330C596 H39
R-47	Buffer Voltage Divider	6.8 K, $\pm 5\%$, 1/2 W	330C664 H69
R-48	Buffer Voltage Divider	15 K, $\pm 5\%$, 1/2 W	330C664 H77
R-49	PA Bias	27 K, $\pm 5\%$, 2 W	330C668 H83

ELECTRICAL PARTS LIST

CIRCUIT SYMBOL	FUNCTION	DESCRIPTION	MANUFACTURER'S DESIGNATION
		<u>RESISTORS (Concluded)</u>	
R-50	Xmtr. PA	Same as R-19	
R-52	Q-12 Emitter	10 Ohms, $\pm 5\%$, 1/2 W	330C664 H01
R-55	Q-15 Emitter	Same as R-52	
R-59	Xmtr. Bleeder	47 Ohms, $\pm 10\%$, 1/2 W	330C595 H09
R-60	Recvr. Bleeder	1 K, $\pm 5\%$, 25 W	* 584C416 H62
R-61	Recvr. Bleeder	600 Ohms, $\pm 5\%$, 25 W	* 584C416 H57
R-62	Recvr. Bleeder	350 Ohms, $\pm 5\%$, 25 W	584C416 H52
R-64	Xmtr. Bleeder	1200 Ohms, $\pm 5\%$, 25 W	584C416 H64
R-66	T-7 Load	560 Ohms, $\pm 5\%$, 2 W	330C668 H43
R-67	Xmtr. Blocking	10 Ohms, $\pm 5\%$, 2 W	330C668 H01
R-68	Xmtr. Blocking	10 K, $\pm 10\%$, 10 W	330C577 H01
R-69	Q-10 Emitter	Same as R-19	
R-70	FL2 Decoupling	470 Ohms, $\pm 10\%$, 1/2 W	330C595 H21
R-71	Q-4 Emitter	Determined in test	
R-72	Q-5 Emitter	Determined in test	
R-73	Q-5 Base	220 Ohms, $\pm 10\%$, 1/2 W	187A641H11
R-74	Q-4 Base	1K, $\pm 5\%$, 1/2 W	184A763H27
R-75	Q-4 Collector	22 K, $\pm 10\%$, 1/2 W	330C595 H41
R-76	Q-5 Collector	Same as R-75	

ELECTRICAL PARTS LIST

CIRCUIT SYMBOL	FUNCTION	DESCRIPTION	MANUFACTURER'S DESIGNATION
<u>TRANSFORMERS</u>			
T-1	Rcvr. Input	Impedance Ratio 10 K; 10K	* 714B677G01
T-2	Rcvr. Osc.	Impedance Ratio 10 K: 400 ohms	* 205C043G01
T-3	Rcvr. Mixer	Impedance Ratio 25 K: 300 ohms	205C043G03
T-4	IF Output	Impedance Ratio 4 K: 500 ohms	* S#1962693, L-592289
T-5	Xmtr. Osc.	Same as T-2	
T-6	Xmtr. Buffer	Impedance Ratio 10 K: 400 ohms CT	* 714B666G01
T-7	Xmtr. Output	Impedance Ratio 1930: 60	S#1962694, I.-633000
<u>TEST POINTS</u>			
TP-1	R-5	Terminal studs	330C592 H02
TP-2	R-8	Same as TP-1	
TP-3	R-17	Same as TP-1	
TP-4	R-18	Same as TP-1	
TP-5	R-28	Same as TP-1	
TP-6	R-39 & R-40	Same as TP-1	
TP-7	R-41	Same as TP-1	
TP-8	R-45	Same as TP-1	
TP-9	R-47	Same as TP-1	

ELECTRICAL PARTS LIST

CIRCUIT SYMBOL	FUNCTION	DESCRIPTION	MANUFACTURER'S DESIGNATION
		<u>SOCKETS</u>	
X-1	FL-1	Octal	330C689 H01
X-2	FL-2	Same as X-1	
X-4	Rear Mounted Voice Adaptor	Same as X-1	
XY-1	Rec. Y-1	Crystal	584C606 H01
XY-2	Xmtr. Y-2	Same as XY-1	
		<u>CRYSTALS</u>	
Y-1	Rcvr. Osc.	Specify Channel Freq. Plus 20-kHz.	328C083
Y-2	Xmtr. Osc.	Specify Freq. Same as Channel Frequency	328C083
		<u>RESERVE SIGNAL DETECTOR</u> (S#470D167G02)	
R-1	Resistor, Level Control	200 K, 2 W, Pot.	184A086H27
R-2	Resistor, Limiting	2000 ohms, 2" tube.	1267296
S-1	Test Switch	SPST Normally Open	327C854 H01

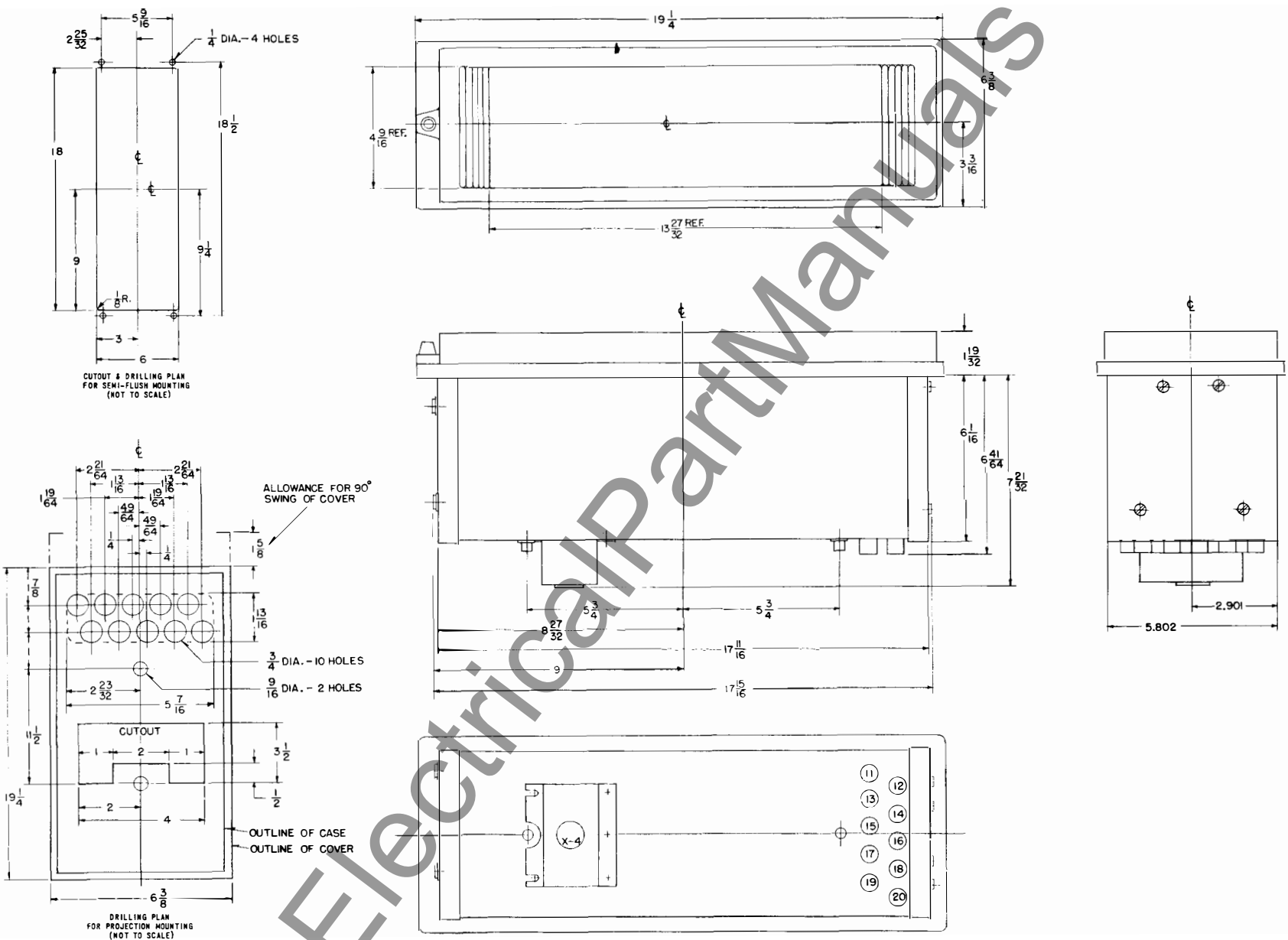
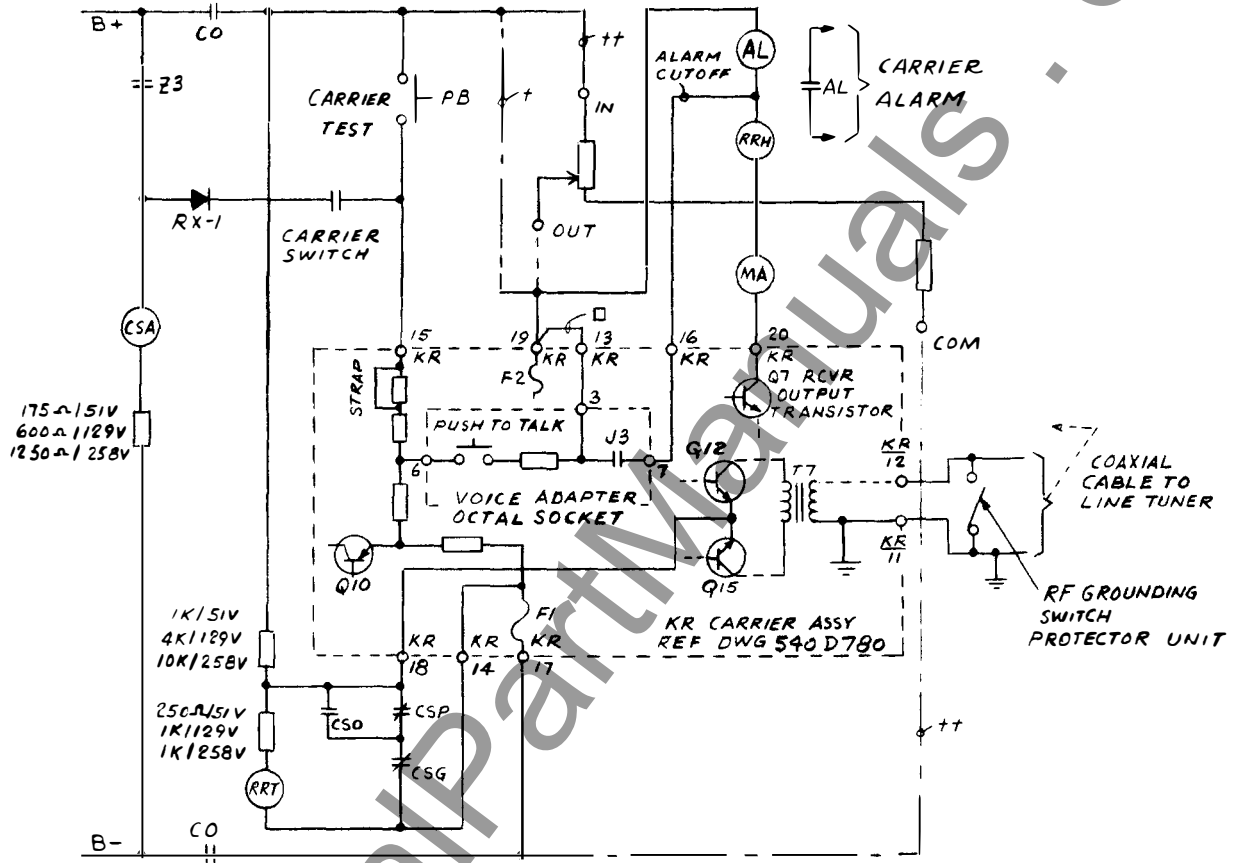

Fig. 1 Outline Drawing, (Flexitest Case) (540D753)

TYPE KR CARRIER SET



REQUIREMENTS FOR HZ/HM RELAYING

SUPPLY VOLTAGE	CARRIER START	CARRIER STOP	STRAP
51VDC	+51V, 7MA	+28V	IN
129VDC	+129V, 8MA	+40V	IN
258VDC	+258V, 8MA	+40V	OUT

KR RELAYING TRANSMITTER /
RELY EXTERNAL CONNECTIONS

TERMINAL CONNECTIONS

- 11. GROUND
- 12. COAXIAL CABLE
- 13. SUPERVISORY PREFERENCE CONTACT
- 14. CARRIER STOP B-RETURN
- 15. CARRIER START (POSITIVE)
- 16. ALARM CUTOFF FOR COMMUNICATIONS
- 17. B MINUS
- 18. CARRIER STOP (HZ/HM)
- 19. B PLUS
- 20. RELAY COIL

NOTES

- + FOR 51 & 129 VDC SUPPLY.
- ++ FOR 258 VDC SUPPLY USE 330C191H01 RESISTOR UNIT REF DWG 223B497
- FOR SUPERVISORY CONTROL PREFERENCE CONTACTS.

Fig. 3- Relaying Control Circuits - HZ/HM (Dwg. 1-329C704)

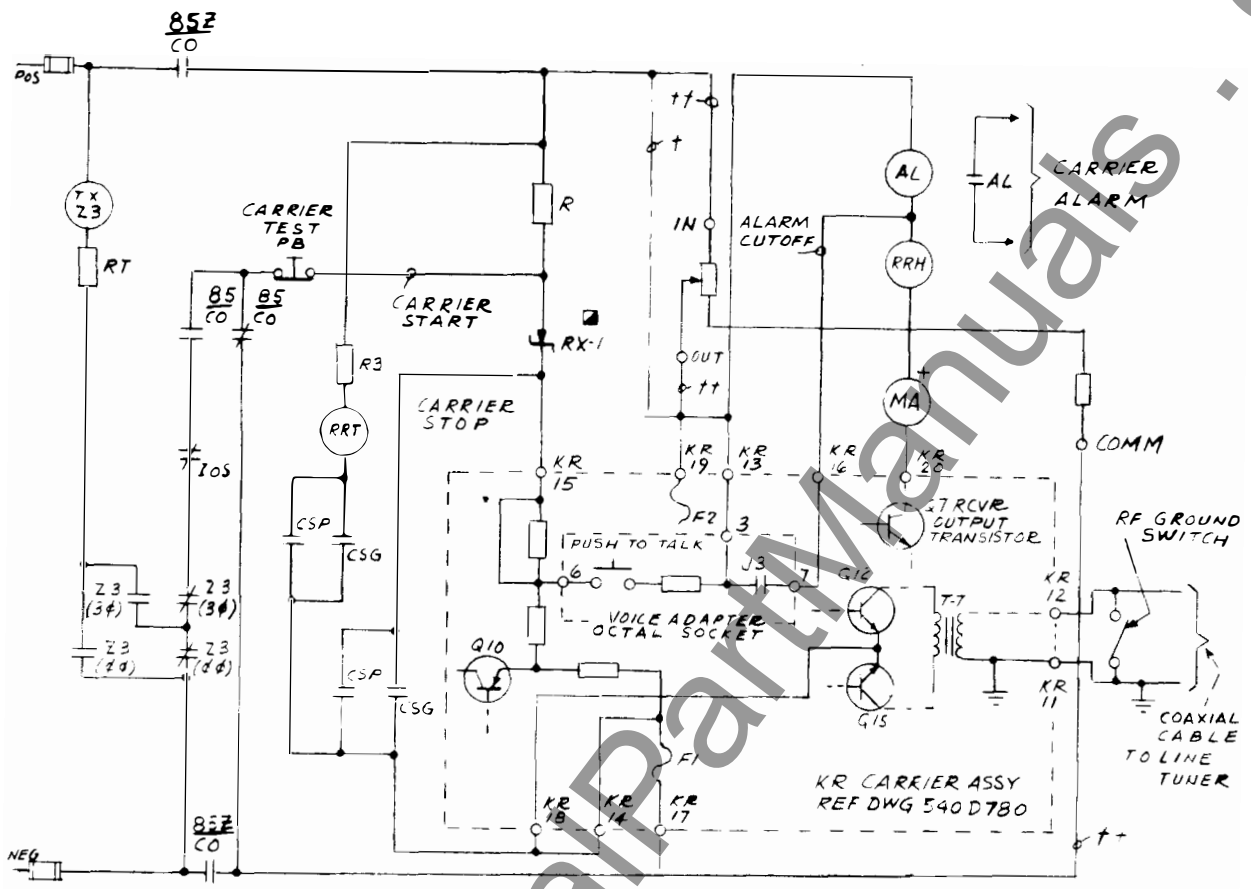

REQUIREMENTS FOR K-DAR RELAYING

SUPPLY VOLTAGE	CARRIER START	CARRIER STOP	R
51 VDC	+ 37 V 7MA	0 VOLTS	2K
129 VDC	+ 100 V 5 MA	0 VOLTS	3.75K
258 VDC	+ 100 V 5 MA	0 VOLTS	19K

NOTES

- KR RELAYING TRANSMITTER /
 RECV EXTERNAL CONNECTIONS
 TERMINAL CONNECTION
- 11 GROUND
 - 12 COAXIAL CABLE
 - 13 SUPERVISORY PREFERENCE CONTACT
 - 14 CARRIER STOP B-RETURN
 - 15 CARRIER START (POSITIVE)
 - 16 ALARM CUTOFF FOR COMMUNICATIONS
 - 17 B MINUS
 - 18 CARRIER STOP (HZ/HZM)
 - 19 B PLUS
 - 20 RELAY COIL

- TYPE IN3051 IN CARRIER AUX. RELAY
- + FOR 51 & 129 VDC SUPPLY
- ++ FOR 258 VDC SUPPLY USE 330C191H01 RESISTOR UNIT REF DWG 223.B.497

Fig. 4-Relaying Control Circuits-K-Dar (Dwg. 3-329C704)

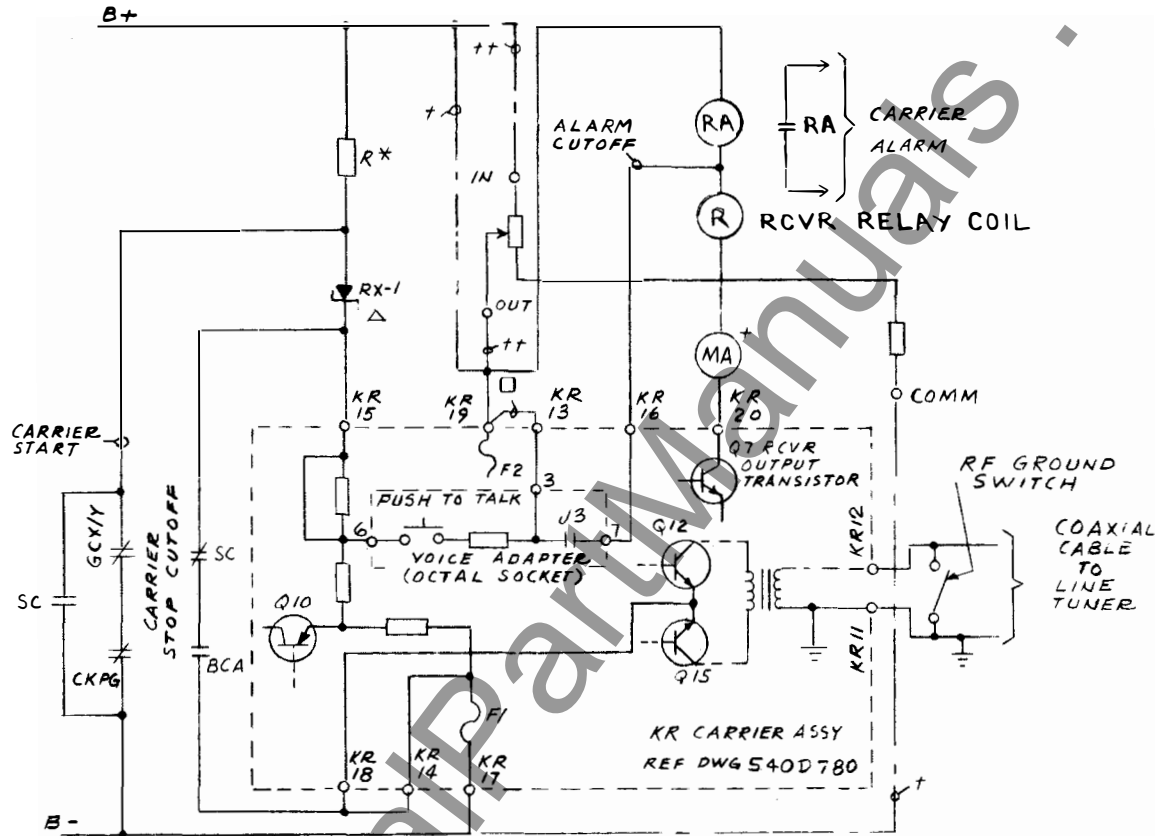

REQUIREMENTS FOR GCX/GCY RELAYING

SUPPLY VOLTAGE	CARRIER START	CARRIER STOP	R
51 VDC	+ 37V, 7MA	0 VOLTS	2K
129 VDC	+ 100V, 8MA	0 VOLTS	3.75K
258 VDC	+ 100V, 8MA	0 VOLTS	19.K

KR RELAYING TRANSMITTER /
REC. EXTERNAL CONNECTIONS
TERMINAL CONNECTION

- 11. GROUND
- 12. COAXIAL CABLE
- 13. SUPERVISORY PREFERENCE CONTACT
- 14. CARRIER STOP B- RETURN
- 15. CARRIER START (POSITIVE)
- 16. ALARM CUTOFF FOR COMMUNICATIONS
- 17. B MINUS
- 18. CARRIER STOP (HZ/HZM)
- 19. B PLUS
- 20. RELAY COIL

NOTES

- * FOR 'R' USE OHMITE VITREOUS ENAMELED DIVIDOHM ADJUSTABLE 4K OR 20K 25W RESISTOR, CONNECT & ADJUST FOR VALUES SHOWN
- Δ TYPE IN3051
- + FOR 51 & 129 VDC SUPPLY
- ++ FOR 258VDC SUPPLY USE 330C191H01 RESISTOR UNIT REF DWG 223B497
- FOR SUPERVISORY CONTROL PREFERENCE CONTACTS

Fig. 5. Relaying Control Circuits - GCX/GCY (Dwg. 2-329C704)

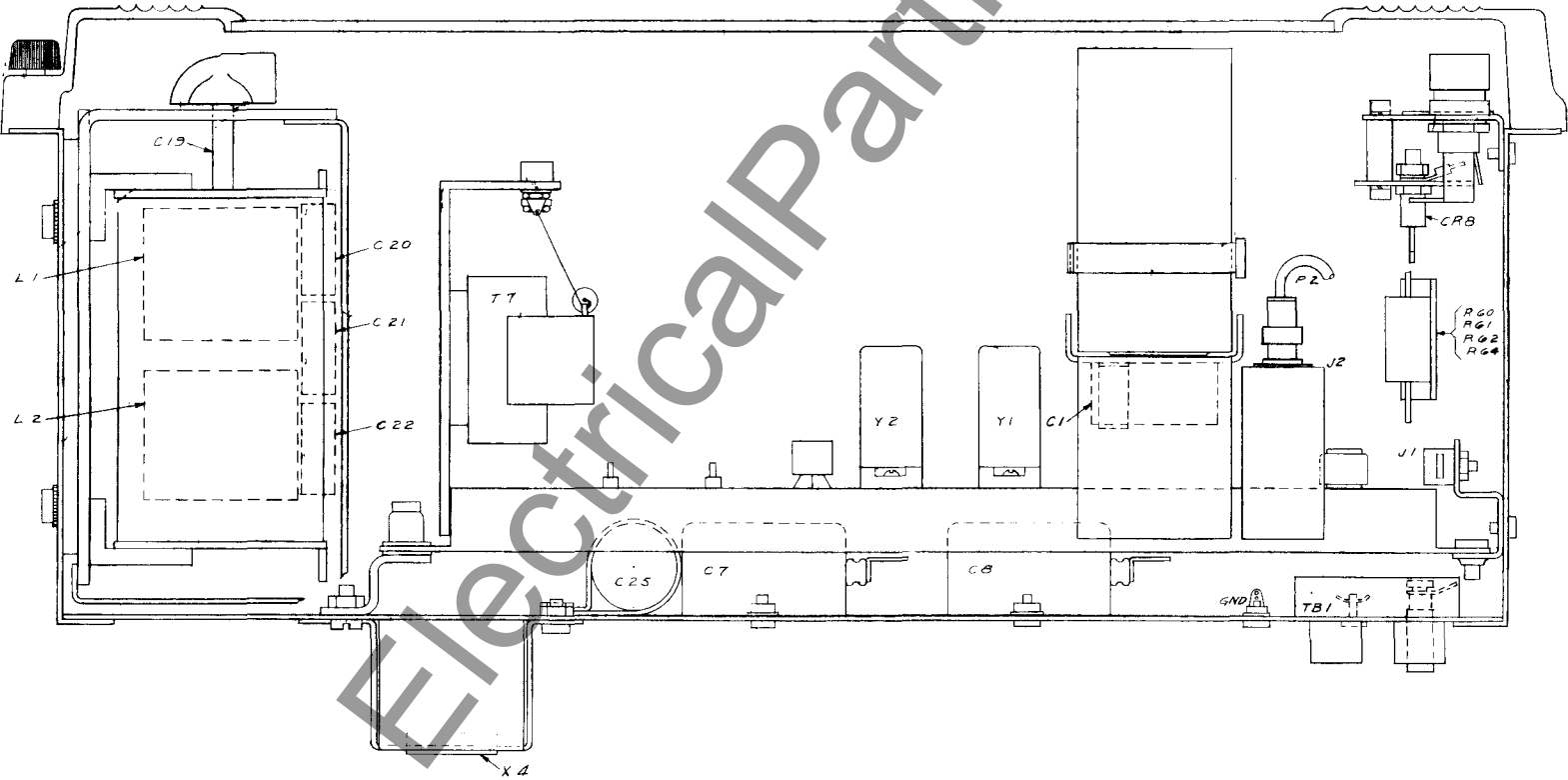
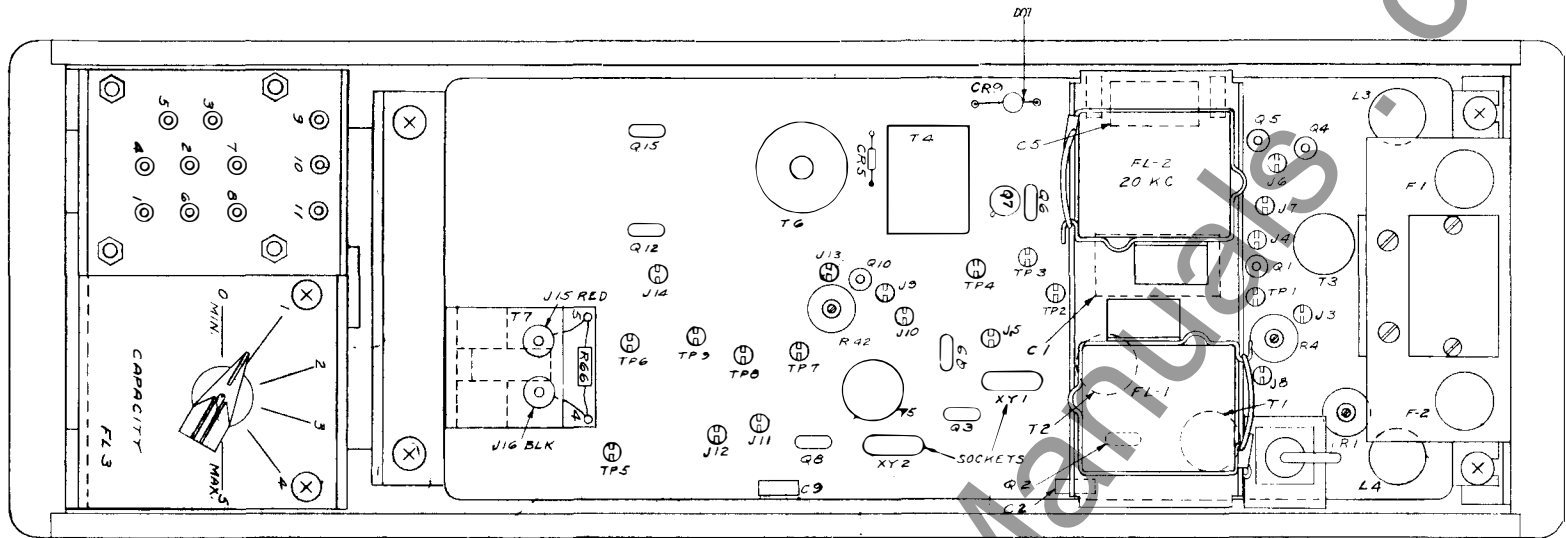
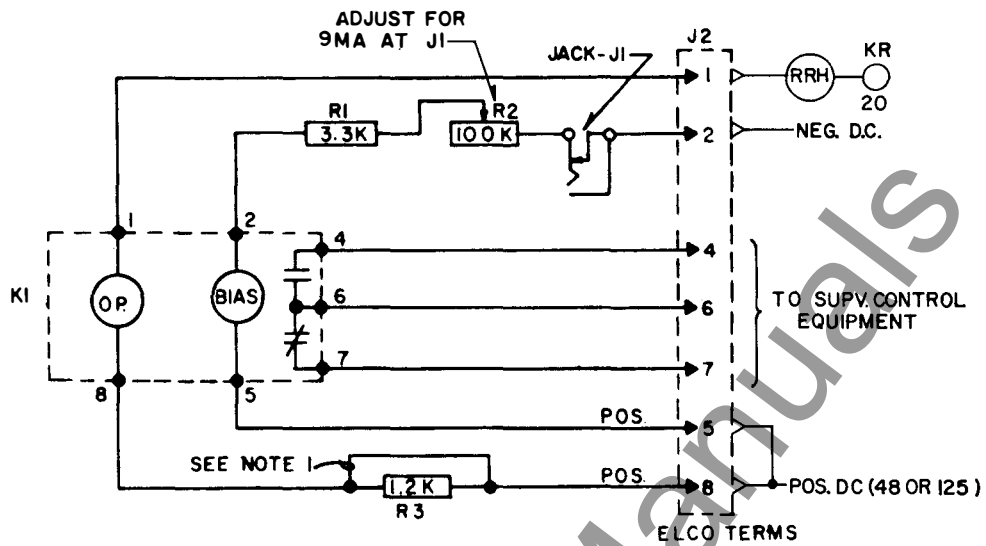
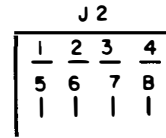

Fig. 6. Component Location (Dwg. 540D781)



NOTES:

1. REMOVE FOR KR CARRIER PLUS SUPV. CONTROL WITHOUT RELAYING.
2. POLARITY SHOWN CLOSES CONTACT BETWEEN TERMINALS 4 & 6.



AS VIEWED FROM REAR OF PANEL

629A552

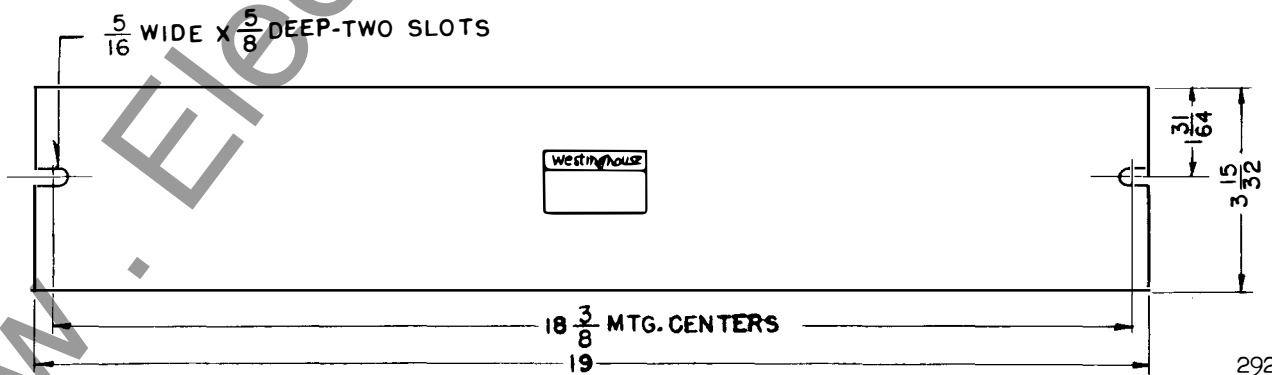

292B991

Fig. 7. Supervisory Control Auxiliary Relay Connections (Dwg. 629A552) and Outline (Dwg. 292B991).

**CONNECTIONS FOR 48-250 VOLT SERVICE AND
SUPERVISORY CONTROL APPLICATION
(CHANGES FROM JUMPERS SHOWN ON INTERNAL SCHEMATIC, FIG.2)**

250-VOLT OPERATION

FOR A 250 VOLT SUPPLY, RESISTOR UNIT 330C191M01 IS USED AS SHOWN ON APPLICATION DRAWING 329C704

FOR HZ/HZM OPERATION, THE JUMPER HAS BEEN REMOVED FROM TP-6 TO TP-7. (NOT REMOVED FOR K-DAR RELAYING).

RESISTOR UNIT SCHEMATIC:

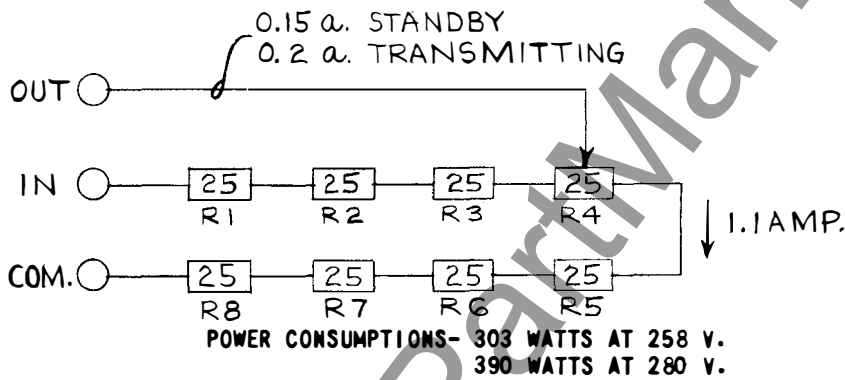

NOTE: KR SUPPLY VOLTAGE WILL BE APPROXIMATELY 144 VOLTS UNDER STANDBY CONDITION WHEN BATTERY VOLTAGE IS 280 VOLTS.

125-VOLT HZ/HZM OPERATION

JUMPER TP-7 AND TP-8 IS REMOVED.

48 VOLT OPERATION

ON PRINTED CIRCUIT BOARD ADDITIONAL JUMPERS ARE CONNECTED AS FOLLOWS:

- BETWEEN TP8 AND TP9
- BETWEEN TP5 AND J12
- BETWEEN TP1 AND TP2
- BETWEEN TP3 AND TP4

IN THE FT CASE, JUMPERS ARE CONNECTED ACROSS R60 AND R64, AND THE CONNECTION BETWEEN R64 AND DIODE CR8 IS REMOVED.

IN ADDITION, FOR 48-VOLT SUPERVISORY CONTROL, R59 IS CONNECTED INTO THE CIRCUIT.

Fig. 8. Connections, 48-250 Volts and Supervisory Control (Dwg. 407C971)

TRANSMITTER OUTPUT FILTER FL-3 CONNECTIONS

<u>LINE</u>	<u>FREQUENCY RANGE</u>	<u>COIL</u>	<u>COIL CONNECTIONS</u>	<u>PARALLEL CAPACITOR CONNECTIONS</u> Δ
1	27.7 KHZ-30.0 KHZ	L-1	(1-5) (3-6)	6-8-9-10-11
2	29.8 KHZ-33.1 KHZ	L-1	(1-5) (3-6)	6-8-10-11
3	31.8 KHZ-36.0 KHZ	L-1	(1-5) (3-6)	6-8-9-11
4	35.4 KHZ-39.0 KHZ	L-1	(1-5) (3-6)	6-8-11
5	38.0 KHZ-41.0 KHZ	L-1	(1-2) (3-6)	6-8-9-10-11
6	40.3 KHZ-45.0 KHZ	L-1	(1-2) (3-6)	6-8-10-11
7	43.0 KHZ-49.0 KHZ	L-1	(1-2) (3-6)	6-8-9-11
8	47.7 KHZ-56.0 KHZ	L-1	(1-2) (3-6)	6-8-11
9	49.5 KHZ-58.5 KHZ	L-1	(1-2) (3-6)	6-8-9-10
10	57.0 KHZ-72.3 KHZ	L-1	(1-2) (3-6)	6-8-10
11	67.0 KHZ-76.0 KHZ	L-2	(1-4) (6-7)	6-8-9-11
12	75.0 KHZ-88.0 KHZ	L-2	(1-4) (6-7)	6-8-11
13	77.5 KHZ-93.0 KHZ	L-2	(1-4) (6-7)	6-8-9-10
14	89.3 KHZ-114.5 KHZ	L-2	(1-4) (6-7)	6-8-10
15	102.7 KHZ-147.0 KHZ	L-2	(1-4) (6-7)	6-8-9
16	136.6 KHZ-210.0 KHZ	L-2	(1-4) (6-7)	6-8

Δ =CONNECTION FROM 6 TO 8 IS MADE BENEATH TERMINAL PLATE ON ALL SETS AT THE FACTORY.

Fig. 9. Connections - Output Filter (Dwg. 149A420)

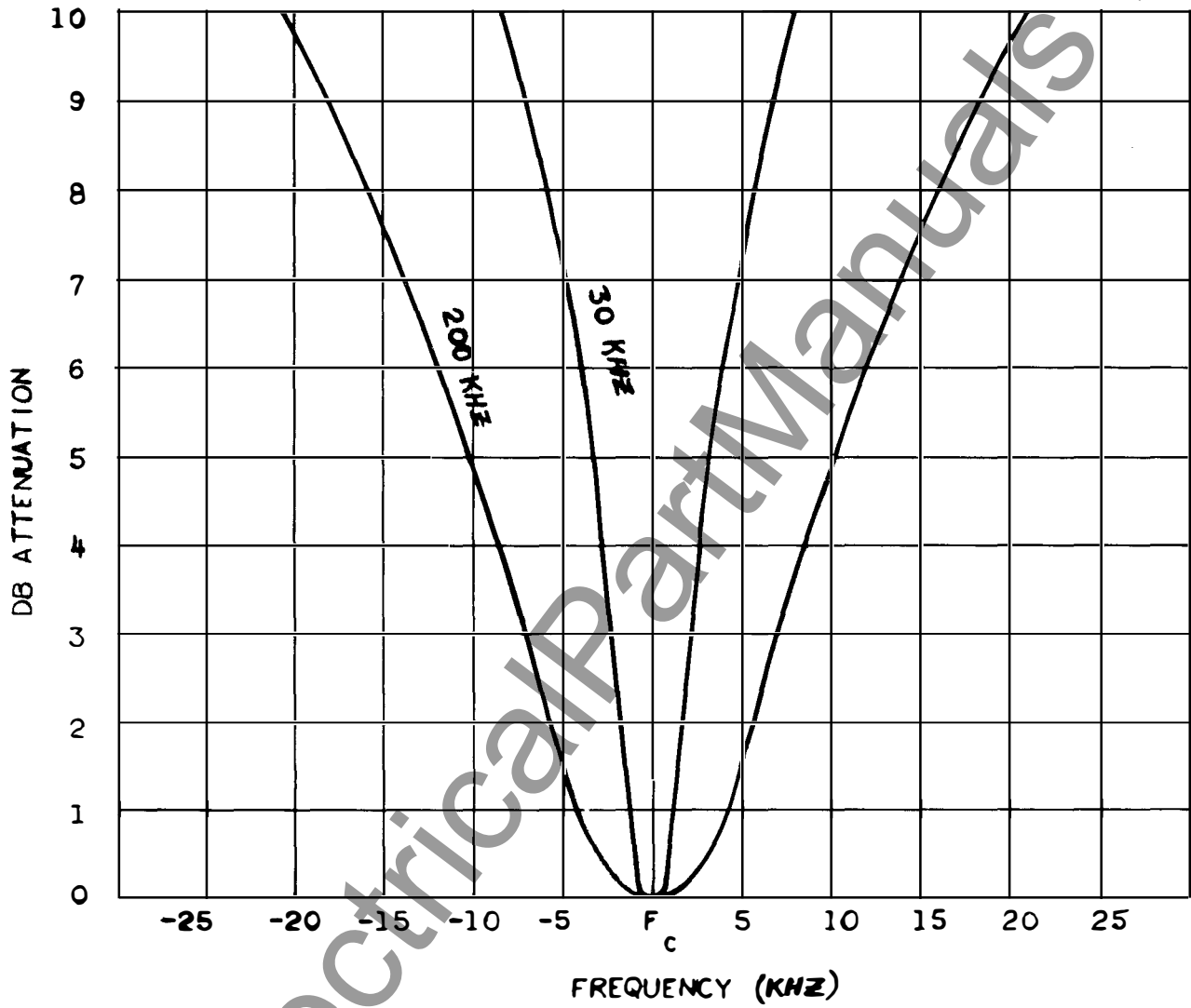
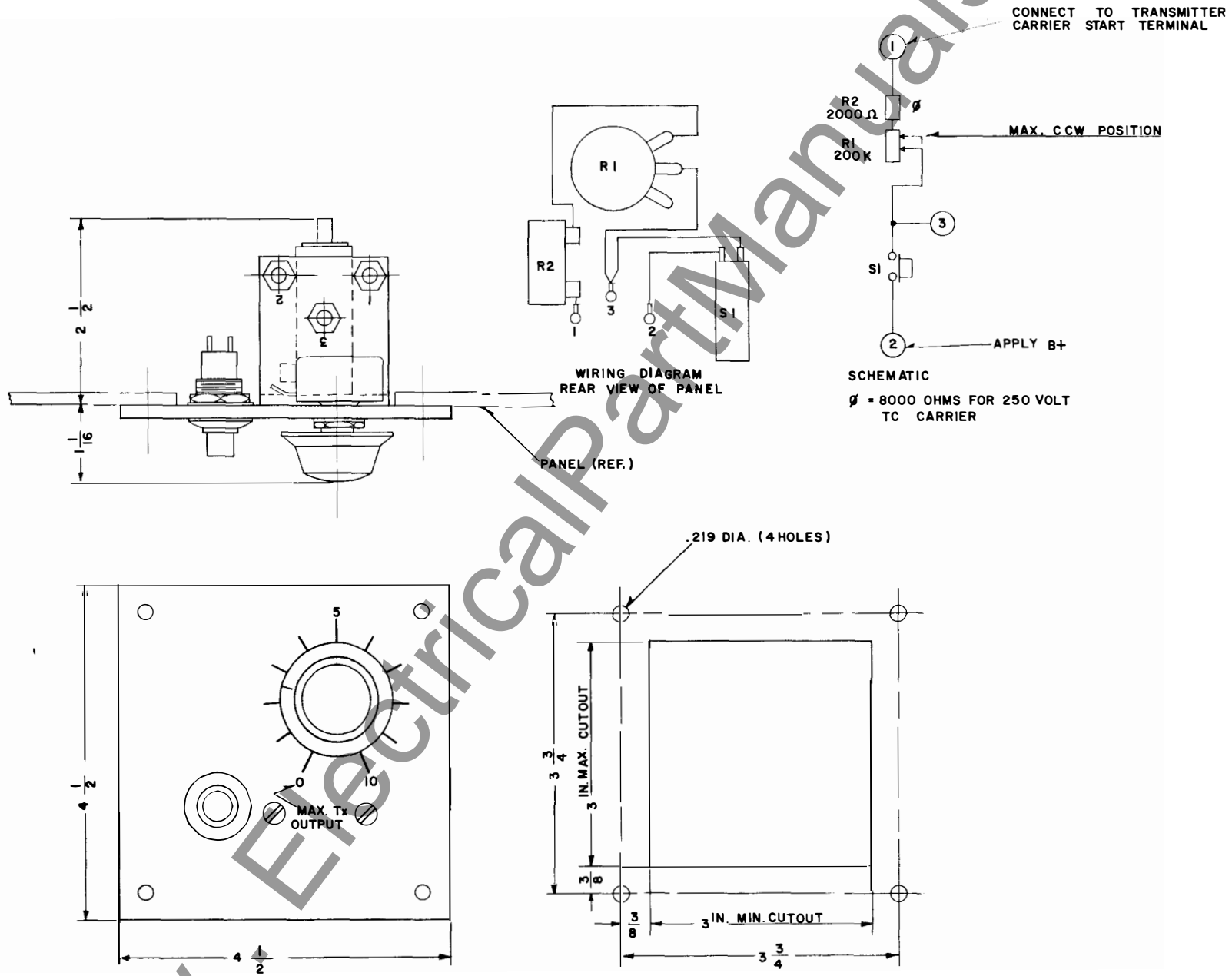

Fig. 10. Transmitter Output Filter Selectivity (Dwg. 377996)

Fig. 11. Reserve Signal Detector Outline (Dwg. 329C703)



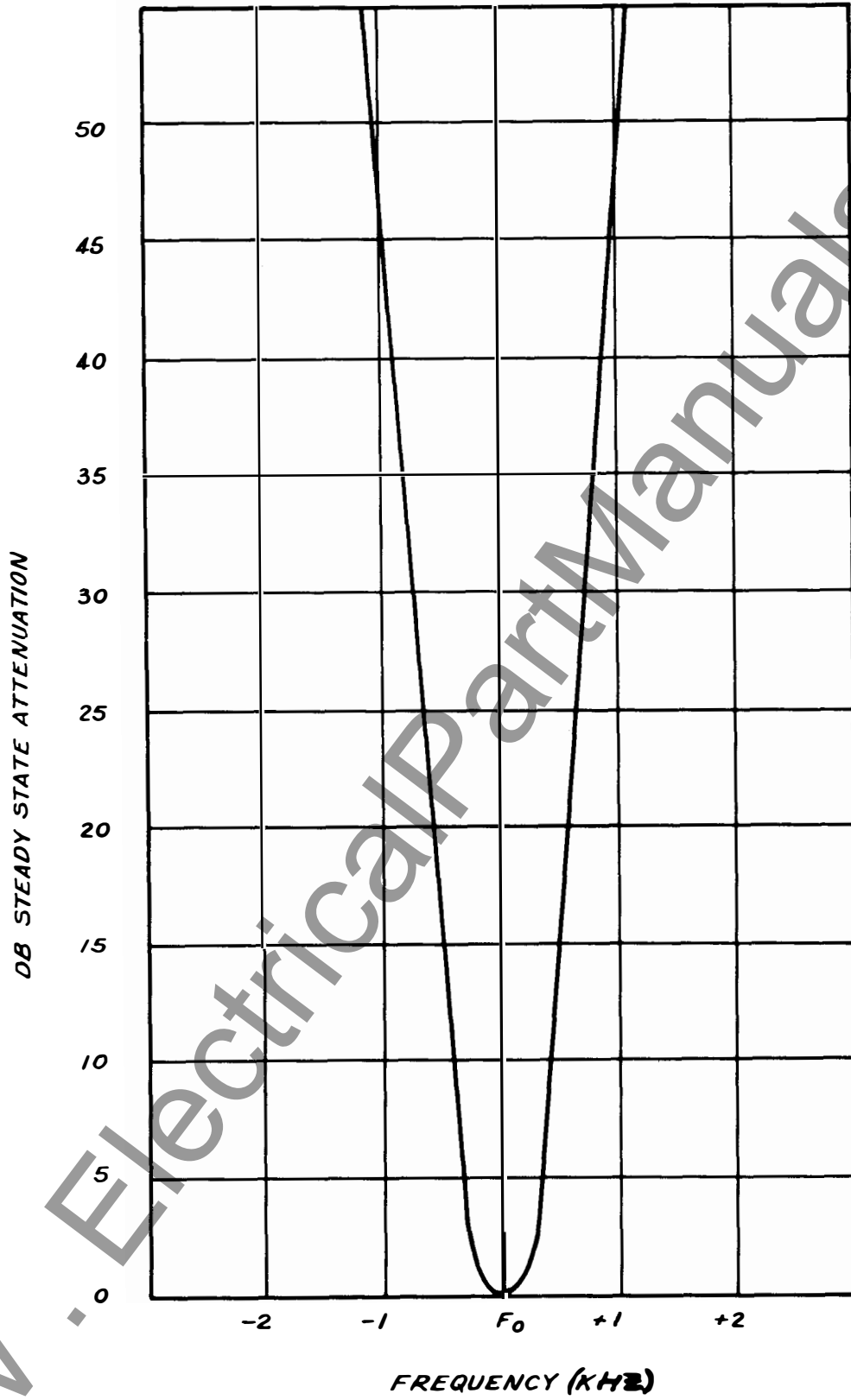
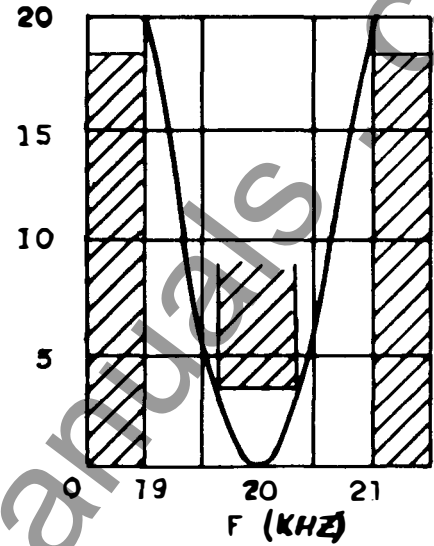
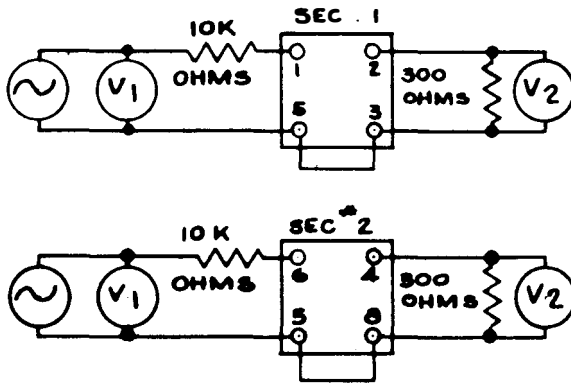

Fig. 12. Receiver Selectivity (Curve #377993)

IF FILTER TEST CIRCUIT



Each section of FL-2 requirement with typical selectivity curve. Insertion loss 26 DB max. including matching resistor.

FOR BOTH CURVES

$$DB = 20 \log \frac{V1}{V2}$$

RF FILTER TEST CIRCUIT

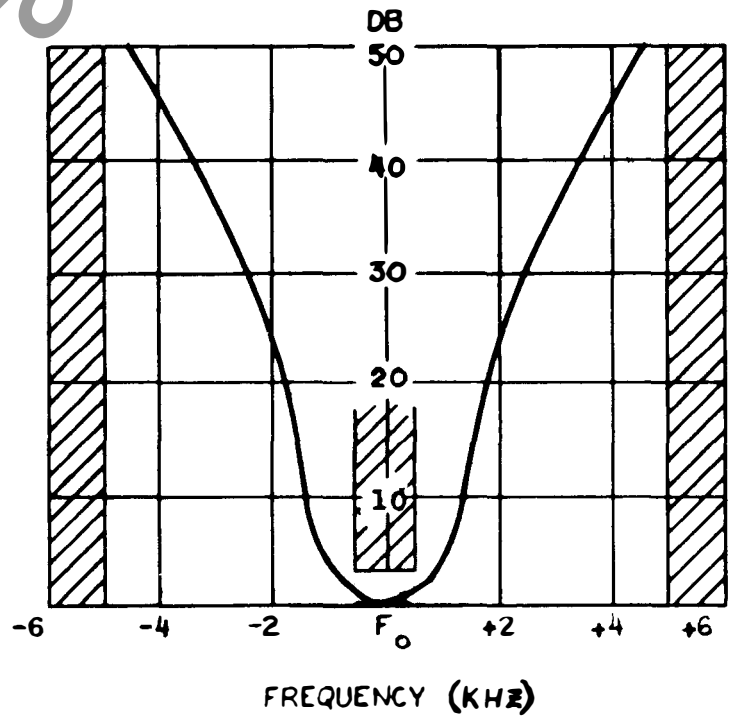
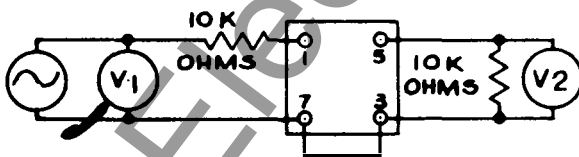

FL-1 requirement with typical selectivity curve at 120 KHZ. Insertion loss 22 DB max. including matching resistor.

* Fig. 13. Receiver Filter Limits (Curve #377995)

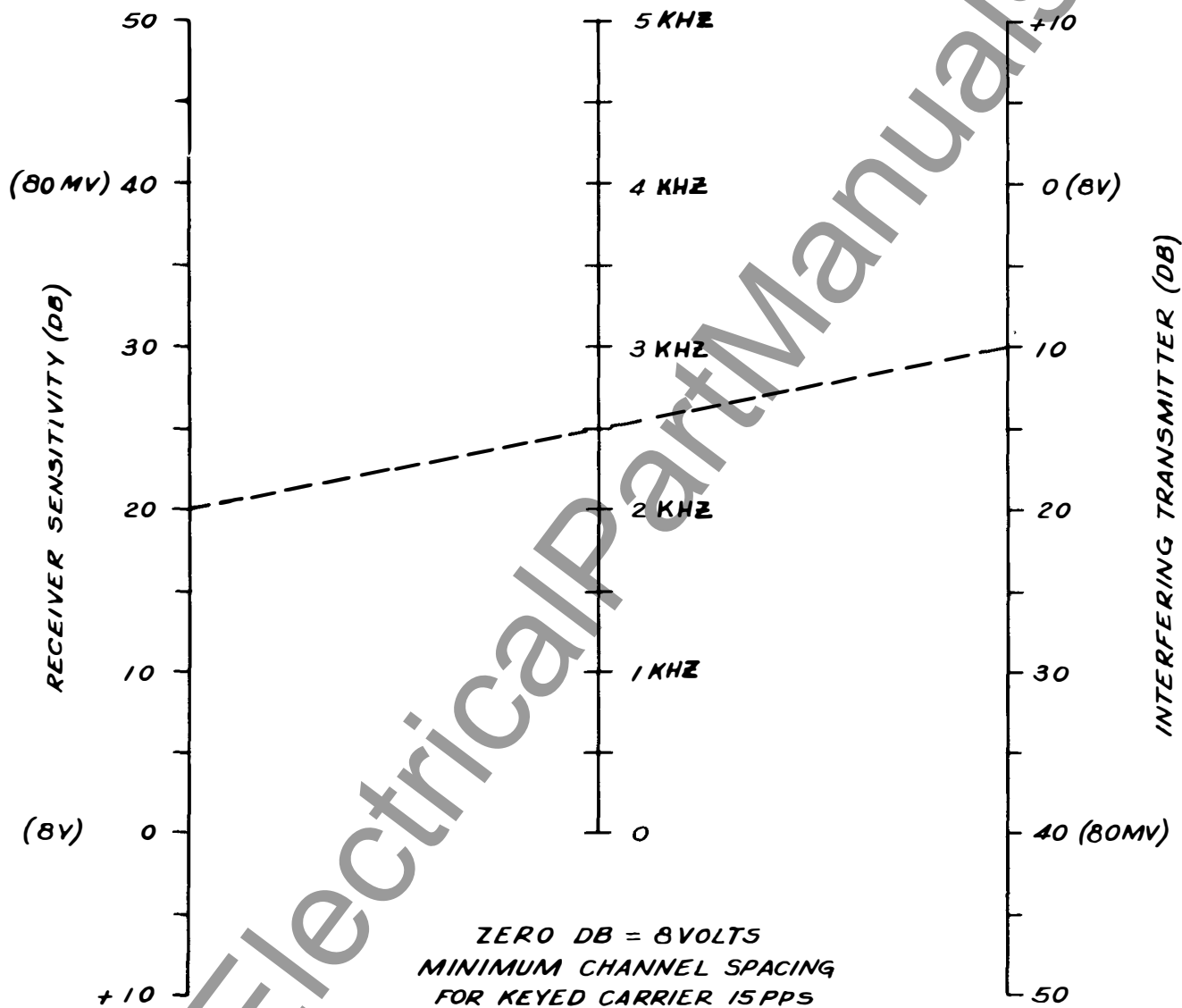
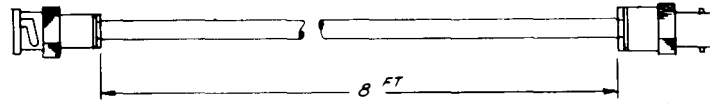
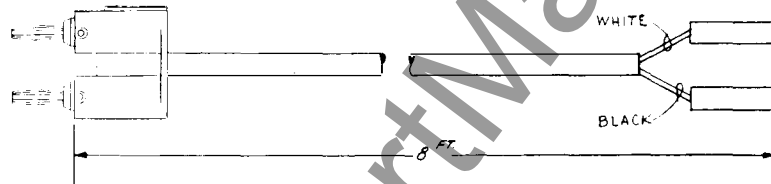

Fig. 14. Minimum Channel Spacing (Curve #377998)



Coaxial Lead... 756D346 G02



Output Lead... 756D346 G03

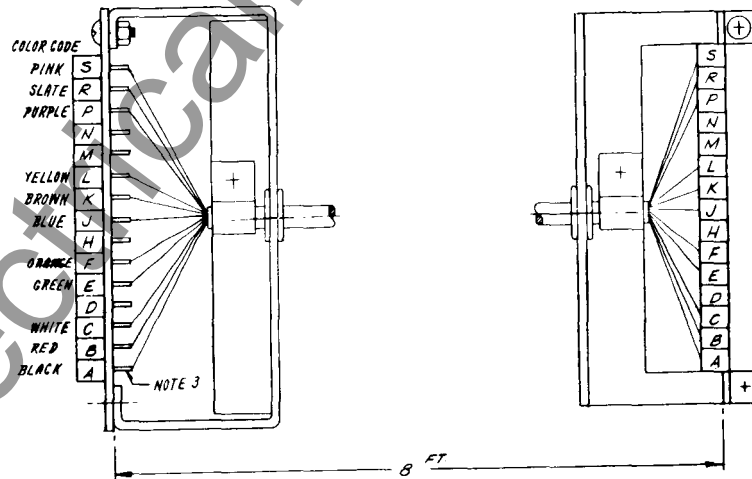

Main Harness... 756D346 G04

Fig. 15. Test Harness - (Complete Set)

www.ElectricalPartManuals.com

www.ElectricalPartManuals.com

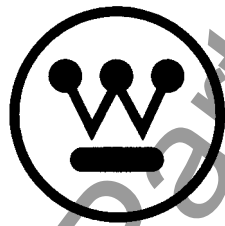

WESTINGHOUSE ELECTRIC CORPORATION
RELAY-INSTRUMENT DIVISION

NEWARK, N. J.

Printed in U.S.A.

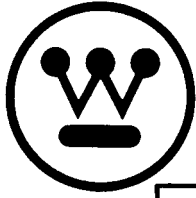

INSTALLATION • OPERATION • MAINTENANCE I N S T R U C T I O N S

TYPE KR CARRIER RELAYING TRANSMITTER-RECEIVER

Flexitest Case Mounted —with provision for rear-mounter Voice Adapter Accessories.	Style
KR Reserve Signal Detector	470D167 G02
250 Volt Resistor Unit	330C191 H01
Test Harness (Complete Set)	756D346 G01
Coaxial Lead	756D346 G02
Output Lead	756D346 G03
Main Harness	756D346 G04

TABLE OF CONTENTS

Introduction Page 2

Specifications Page 2

Description

 General Page 3

 Mechanical Page 3

 Electrical

 Transmitter Page 4

 Receiver Page 4

 Transmitter Control Circuits Page 5

 Reserve Signal Detector Page 5

 Communications Page 5

 Relaying Control Circuits Page 5

Installation

 General Page 6

 Connections

 External Page 6

 Internal Page 7

Adjustments

 Transmitter Page 7

 Receiver Page 7

 Reserve Signal Detector Page 8

 250-Volt Resistor Unit Page 8

 Frequency Change Page 8

Maintenance Page 9

Application Page 13

Electrical Parts List Page 14

LIST OF TABLES

Table

1 D-C Pin Jack Measurements with Reference to B- Page 10

2 Transistor DC Measurements with Reference to B- Page 11

3 D-C Bleeder Measurements with Reference to B- Page 12

4 Typical RF Signal Measurements for Receiver Page 12

5 Typical RF Signal Measurements for Transmitter Page 13

LIST OF ILLUSTRATIONS

Figure	References
1 Outline – Flexitest Case	540D753
2 Internal Schematic	540D780
3 Relaying Control Circuits (HZ/HZM)	1-329C704
4 Relaying Control Circuits (K-Dar)	3-329C704
5 Relaying Control Circuits (GCX/GCY).....	2-329C704
6 Component Location.....	540D781
7 Supervisory Control Receiver Connection	223B498
8 Connections, 48-250 volts and Supervisory Control.....	407C971
9 Transmitter Output Filter Connections	149A420
10 Transmitter Output Filter Selectivity.....	C377996
11 Reserve Signal Detector – Outline and Schematic	329C703
* 12 Receiver Selectivity	C377993
13 Receiver Filter Limits	C377995
14 Minimum, Channel Spacing	C377998
15 Test Harness	756D346

CAUTION The voltages encountered in this equipment are dangerous to life. To be safe, disconnect the power source and close the grounding switch when servicing the equipment.

INTRODUCTION

The Type KR Relaying Transmitter-Receiver is designed for Distance Relaying, Telemetry, Supervisory Control and Sleet Detection. Facilities are provided for a plug-in type voice adapter. The basic design is for operation from 125-volt station batteries. However, the apparatus may also be operated from 48-volt or 250-volt station batteries by means of various internal connections. These various connections as well as most of the adjustments are made at the factory, although they can be changed in the field.

Although designed primarily for operation with Westinghouse protective relays, this apparatus may also be coordinated with other types of directional-distance relays and with most other contact keyed devices.

SPECIFICATIONS

Frequency Range.....	30-kHz to 200kHz
Channel Attenuation Rating	40-db
Transmitter Power Output	1.0 watt with a 125 V.D.C. * supply. 0.5 watt with a 48-volt d-c supply.
Transmitter Harmonic Output	At least 46-db below funda- mental.
Transmitter Output Impedance.....	Matches one 60-ohm coax. cable. (Suitable for 50-70 ohm cable.)
Transmitter Output Filter Selectivity	See Fig. 10
Transmitter and Receiver Oscillator and Frequency Stability	From - 20°C to +55°C with si- * multaneous voltage variations from 105 to 140 VDC, the fre- quency remains with 0.01%.

Permissible Battery Voltage Ripple	7-½%
Ambient Temperature Range	- 20° C to + 55° C.
* Receiver Maximum Sensitivity025 volts for 10 ma. output.
Receiver Selectivity	See Fig. 12
Receiver Signal-to-Noise Ratio Requirements	12-db
Minimum Channel Spacing	See Fig. 14
Power Input	115-ma at 48 VDC, 200-ma at 125 VDC, 1.28 amperes at 250 VDC.
Carrier On-Off Keying	Requires one pair of con- tacts capable of keying 8-ma DC at an open circuit voltage of 125 VDC.
Weight (With Flexitest Case)	Approximately 16-lbs.

CAUTION Refer application to Westinghouse when other transmitters are to be connected to the same coax cable as certain conditions may result in damage to the output transistors.

such as potentiometers, jack, test points, crystals, transistors, etc. External connections and the Schematic Diagram are shown by Fig. 2. The numbered terminals shown as squares apply to the external terminals.

DESCRIPTION

Mechanical

This apparatus is supplied in a Flexitest case and may be either flush or projection mounted in order to match other switchboard equipment. The outline dimensions and also the drilling plan for flush and projection mounting are shown by Fig. 1. The majority of the parts are mounted on a printed circuit board. This board may be readily removed as follows:

1. Remove the two output plugs from the red and black jacks.
2. Disconnect the receiver input coaxial cable connector.
3. Loosen the two screws at the top of the board.
4. Loosen the two screws at the bottom of the board and pull them out as far as they will extend.
5. Pull board down to disengage the terminals and lift out.

The transmitter output filter may be removed by removing four mounting screws from the bottom of the case and disconnecting the coaxial cable.

Fig. 6. shows the location of major components

Provisions are made for plugging the Voice Adapter Unit in the rear of the relaying equipment. Octal socket marked X-4 on the rear of the set accommodates the adapter plug. A buckle type strap on each side of the adapter holds the unit in place after it has been plugged in. The normal projection for a rear mounted Voice Adapter is 3-inches beyond that of the relaying equipment. When the KR Relaying Unit is supplied with the adapter, a patch cord is available on separate order. This patch cord plugs into the telephone jacks on the adapter and provides an extension to a conveniently located terminal board.

The panel cutout information necessary for mounting the Reserve Signal Detector is shown by Fig. 11. This unit consists of a potentiometer and pushbutton switch mounted on a small panel, itself suitable for switchboard mounting.

For 250-volt operation, separate auxiliary resistors are required, as shown in Fig. 8.

Electrical

Transmitter

The transmitter is made of four main stages in -

cluding an oscillator, driver, power amplifier, and an output filter. In the oscillator, the crystal is operated as a resonant circuit between the collector of one transistor and the base of the other. The feedback is supplied through a capacitor from the collector of the second transistor to the base of the first transistor. The frequency is independent of voltage or temperature changes of the transistors. Thus the frequency stability is the stability of the crystal.

The input to the driver stage Q-10 is controlled by potentiometer, R-42 which also controls the transmitter power output. In HZM relaying CARRIER STOP provides about +40 volts for blocking. This is applied to Q-10 through T-6. Diode CR-5 prevents damage to the transistor when this positive voltage is applied to the collector. For CARRIER START (when in the blocked position) a small positive voltage is applied to the collector of Q-10 by means of bleeder resistors R-67 and R-68.

The power amplifier consists of two transistors Q-12 and Q-15, which are operated as class B amplifiers in push-pull. Resistors R-52 and R-55 are for stabilization.

The output transformer, T-7, matches coaxial cables of 50 to 70 ohms.

Resistor R-66 tends to keep the source impedance constant to permit proper tuning of the output filter.

The output filter consists of coils L-1 and L-2, capacitors C-19 through C-22. The filter is tunable, and is provided to attenuate harmonics and other spurious outputs. It should be noted that the filter contains no shunt elements, resulting in a reverse impedance free of "across the line" resonances.

Receiver

* The receiver is a superheterodyne in order to obtain constant selectivity regardless of the channel frequency. (See Fig. 12) The major stages include an input filter, attenuator, oscillator, mixer, IF filters, IF amplifiers, detector and a D-C power output stage.

The receiver sensitivity is adjusted by means of the continuously variable input control R-1 and by connecting or disconnecting resistors R-73 and R-74 in the IF stages.

The receiver oscillator (Q-2 and Q-3) is basic-

ally the same as the transmitter oscillator. The frequency is 20-kHz above the incoming signal frequency.

The receiver channel frequency is determined by the input filter and the oscillator crystal. The frequency may be changed readily since both the filter and the crystal are plug-in components.

Mixing is accomplished by feeding the incoming signal to the emitter and the receiver oscillator signal to the base of the mixer Q-1. Mixer oscillator requirements are met through adjustment of potentiometer R-4. Injection into two separate elements, base and emitter, provides a circuit capable of handling greater signal level variations than one in which injection is made into only a single element such as the base.

This receiver uses an IF frequency of 20-kHz. The overall selectivity is determined primarily by the IF filter FL-2. Typical characteristics of this filter * are shown in Fig. 13. The IF amplifier consists of transistors Q-4, Q-5 and Q-6.

The detector is a full wave bridge rectifier. This rectifier in conjunction with the IF amplifier Q-6, provides the necessary power to drive the D-C power output stage Q-7. The final output stage Q-7 will supply approximately 18 milliamperes to a standard 1700 ohms distance relay RRH coil and its associated 500 ohm alarm coil. It may also be used to drive other relay coils such as is shown by Fig. 7, Supervisory Control Connections.

Transmitter Control Circuits

In the standby condition, although the oscillator is running, the transmitter driver has no emitter bias which results in no output.

Positive voltage applied to terminal 15 supplies this bias through a voltage dividing network, and transmitter output results. The actual configuration of the network is a function of supply voltage and application (Relaying, Telemetry, etc.) and is discussed in the Adjustments section.

Output may be stopped in several ways. The method used with K-DAR relays is to remove the positive voltage applied to terminal 15. In the case of distance relaying with Westinghouse HZ/HZM relays, application of a positive voltage to terminal

18 will stop the transmitter output. Output may also be stopped by removal of negative battery from terminal 18.

Reserve Signal Detector

The Reserve Signal Detector is shown by Fig. 11. Effectively R-1 is a remote transmitter output control. This control is obtained through varying the driver Stage (Q-10) emitter bias, and is effective over a 25-db range of transmitter output. The detector is switched into service by S-1. By adjusting R-1 for a given receiver relay current at the far end of the channel, a relative measure of the channel attenuation may be obtained. This is discussed further in the section on Adjustments.

Communications

The transmitter output is reduced approximately 6-db when the Type KR voice adapter attachment is used. Relaying takes preference, and full output is * obtained when full voltage is supplied to terminal 15.

Relaying Control Circuits

Figs. 3, 4 and 5 show simplified diagrams of the relaying control circuits.

1. K-DAR and GCY Relaying (Figs. 4 and 5)

The control of the carrier set is obtained through the CARRIER START and CARRIER STOP contacts. These contacts are shown in their normal standby condition.

The K-DAR or GCY relays operating from the voltage and current on the transmission line, detect and determine the direction of a line fault and thereby control the carrier transmitter and receiver.

The control of the carrier set is such as to start the transmission of carrier when fault power on the transmission line is flowing out of the line section being protected. Conversely, when fault power is flowing into this line section, the control is such as to block the transmitter and keep it from being turned on by secondary functions such as reserve signal detection and communication, should these functions be in use at the same time. Should carrier be received from the remote station, the hold coil and alarm coil will energize through transistor Q-7 in the receiver.

When carrier start operation occurs, the CARRIER

START contact opens applying a positive voltage (see Figs. 4 and 5) to terminal 15 of the carrier set. This puts a potential on the driver stage in the transmitter and also applies proper bias for the power amplifier.

When a carrier stop operation occurs, the CARRIER STOP contact closes, which removes B+ (terminal 15) from the driver and the power amplifier stages in the transmitter. CARRIER STOP, terminal 18, on the carrier set is permanently connected to terminal 14, for K-DAR and GCY relaying.

2. HZM Relaying (Fig. 3)

The control of the carrier set is effected by the CARRIER START and the CARRIER STOP contacts. These contacts are shown in their normal standby condition.

The HZ-HZM relays operating from the voltage and current on the transmission line, detect and determine the direction of a line fault and thereby control the carrier transmitter and receiver.

The control of the carrier set is such as to start the transmission of carrier when fault power on the transmission line is flowing out of the line section being protected. Conversely, when fault power is flowing into this line section, the control is such as to block the transmitter and keep it from being turned on by secondary functions such as reserve signal detection and communication, should these functions be in use at the same time. Should carrier now be received from the remote station, the hold coil and alarm coil will energize through transistor Q-7 in the receiver.

When carrier start operation occurs, the CARRIER START contact closes applying the full battery supply voltage to terminal 15 of the carrier set. This puts a potential on the driver stage in the transmitter and also applies proper bias for the power amplifier.

When a carrier stop operation occurs, the CARRIER STOP contact opens. This applies a positive voltage (see Fig. 3) to terminal 18 which blocks the driver stage and the power amplifier stage

It is possible under certain conditions that the signals from two transmitters, attempting to block a third receiver, would be of such amplitude, phase and frequency as to cause the RRH coil current to "pulsate". It would then be possible to have a false trip.

TYPE KR CARRIER SET

In the case of the KR set for relaying 3-terminal lines, the transmitter frequencies (to avoid this possibility of false trip) should be separated by 100 Hz. All receivers and one transmitter would be at the desired center frequency. One of the other transmitters would be 100 Hz above, the other 100 Hz below this center frequency.

INSTALLATION

General

Upon receipt of a unit, whether shipped separately or in an assembly, an immediate inspection should be made. Carefully check for damage or shortages.

For necessary clearances and mounting dimensions, see the following illustrations:

- Flexitest Case Mounting..... Fig. 1
- Reserve Signal Detector Fig. 11

Connections

External

The external connections will vary slightly depending on the application, but in general will be as follows: (Refer to the Schematic Diagram, Fig. 2.)

- Terminals 11..... Ground
- 12..... Coaxial Cable

- 13 and 19..... Supervisory Preference Contacts
- 14..... B- "CARRIER STOP" return
- 15..... Battery positive through carrier start contacts
- 16..... Battery positive for alarm cutoff (used with communication)
- 17..... B-
- 18..... Carrier Stop for HZM Relaying
- 19..... B+
- 20..... Relay Coil

CAUTION If the transmitter output load is removed while the transmitter is energized, the transistors in the power amplifier will be permanently damaged. A dummy load should be connected to the transmitter output if the coax is disconnected and the transmitter is to be energized.

When tuning line coupling equipment, short the coaxial cable to ground before changing taps on the Line Tuner or matching transformer.

Internal

Necessary internal connections are generally made at the factory, to customer order, before apparatus shipment. For reference purposes, these are outlined in the following tabulation. Check the proper bleeder resistors before applying voltage to the equipment.

OPERATION

- 48-Volt K-DAR, HZM, and GCY Relaying, Telemetering, and Supervisory
- 125-Volt K-DAR and GCY Relaying
- 125-Volt HZM Relaying, Telemetering, and Supervisory
- 250-Volt K-DAR and GCY Relaying
- 250-Volt HZM Relaying, Telemetering, and Supervisory

Various combinations of the inductors and capacitors of the transmitter output filter are required depending on the channel frequency. These are tabulated in Fig. 9.

Adjustments

This apparatus is generally tuned to and tested

BLEEDER RESISTORS IN THE CIRCUIT

at the specified channel frequency before shipment. Final adjustments must be made in the field and are described in the following paragraphs. Fig. 6 shows the locations of the various controls.

Transmitter

1. Disconnect the coaxial cable and replace with a 50, 60, or 70 ohm non-inductive resistor depending on the characteristic impedance of the cable used.
2. Fig. 9 shows typical output filter connections for various frequency ranges. In some cases it may be necessary to use either a higher or lower range to tune the filter to resonance.
3. Insert fuses F- 1 and F- 2 to apply power to the apparatus.

4. Connect an A-C Vacuum Tube Voltmeter (VTVM) across the non-inductive load.

R-47 and R-48

R-45, R-47 and R-48

R-41, R-45, R-47 and R-48

R-45, R-47 and R-48

R-39, R-40, R-41, R-45, R-47 and R-48

5. Unblock the transmitter by closing the CARRIER TEST SWITCH. An alternative is to jumper battery positive to terminal 15.

6. Beginning with the output control R-42 at the maximum counterclockwise position, advance it clockwise until a reading appears on the VTVM. Tune capacitor C-19 for a maximum voltmeter reading.

7. While increasing R-42, tune the output filter for maximum output until the output across the resistor is approximately 8 volts. (Approximately 5.5-volts when operating from 48-volt station battery.)

8. Open the test switch and reconnect the coaxial cable.

Receiver

1. The oscillator output control R-4 is pre-set at the factory. However, should any of the oscillator components be changed (including the transistors and the crystal) R-4 will require adjustment.

a. Connect an A-C VTVM to jacks J-3 and J-4.

b. Adjust R-4 for a 0.3 volt reading on the meter.

2. The unit is shipped to have a gain of approximately 250 millivolts (to produce 10 ma relay current) with input control R-1 in maximum clockwise position. About 10-db additional gain or 80 millivolt sensitivity can be obtained by clipping out resistor R-74, which is connected to the base of Q-4 and the B+ supply for the IF. A further 10-db gain or additional 25 millivolt sensitivity can be obtained by also clipping out resistor R-73, which is connected to the base of Q-5 and the B+ supply for the IF. Resistor R-71 and R72 have been selected at the factory to provide an overall gain of approximately 25 millivolts with R73 and R74 removed.

a. Sensitivity Adjustment for Noise

If the maximum on-frequency noise level is known or can be measured, the receiver can be adjusted for this level. Disconnect the coaxial cable and connect a 60-ohm non-inductive resistor and a VTVM across terminals 11 and 12. Energize the transmitter and output control R-42 for the same output as the maximum noise. Then adjust the receiver input control R-1 to obtain 1-ma output current. If it is impossible to obtain 1-ma output current with control R-1 in the maximum clockwise position, then clip out resistor R-74, which is connected to the base of Q-4. If the gain is still insufficient, clip out resistor R-73, which is connected to the base of Q-5. After completing the adjustment of R-1, restore the transmitter to full output.

b. Sensitivity Adjustment for Remote Signal

When the maximum on-frequency noise is unknown and cannot be conveniently measured, the receiver may be adjusted for the remote signal. First determine the channel attenuation using a Sierra voltmeter or some other convenient method. Disconnect the coaxial cable and connect a 60-ohm non-inductive resistor and a VTVM across terminals 11 and 12. Add 15-db to the channel attenuation. This compensates for average variations such as channel and voltage variations. For example, if the channel attenuation is 5-db, add this to the 15-db making a total of 20-db. Taking this from 8 volts output of the transmitter, the receiver should then be set for a sensitivity of 0.8 volts. To do this, adjust the transmitter output control R-42 for 0.8 volts and then adjust the receiver input control so as to obtain 10-ma output current. If it is impossible to obtain 10-ma output current with control R-1 in the maximum clockwise position, clip out resistor R-74, which is connected to the base of Q-4. If the gain is still insufficient, clip out resistor R-73, which is connected to the base of Q-5. After completing the adjustment of R-1, restore the transmitter to full output.

It must be kept in mind that the two preceding adjustment procedures are to be used as a guide and will cover the majority of cases; however, cases may arise where conditions change. For example, if the adjustment is made per part a., the noise may increase due to various reasons such as bad insulators, which would require adjusting the receiver to be less sensitive. In the adjustment of part b., the attenuation may increase due to sleet or line switching,

TYPE KR CARRIER SET

which would necessitate increasing the sensitivity of the receiver.

Reserve Signal Detector

Due to different types of operation and supply voltages, it is not practical to have a calibrated dial for this unit. However, calibration may be made at installation by recording transmitter output (either in db or volts) at various knob settings of the detector unit. Then, by adjusting the knob so as to obtain 10 milliamperes relay current at a remote receiver, any increase or decrease in line attenuation may be noted as the difference between the original setting, and the setting required to obtain the given 10 milliamperes.

250-Volt Resistor Unit

With the apparatus energized, adjust R-4 in the 250-volt resistor unit so as to obtain 125-volts at terminals 17 (B-) and 19 (B+) on the relaying set.

Frequency Change

If the frequency is changed in the field, it is necessary to change the input filter FL-1 to the desired channel frequency. This filter is of the plug-in type and may be removed by unsnapping the clamp and pulling the filter out. The transmitter oscillator crystal Y-2 must be changed to the desired channel frequency. The receiver oscillator crystal Y-1 must be changed to the desired channel frequency plus 20 kHz. Figure 9 shows the connections for the transmitter output filter. It is necessary to unsolder the existing connections and make the new connections per the chart. After completing the preceding, the tuning procedure as described under Adjustments for transmitter and receiver should then be followed.

Note also that capacitors C2 and C9 in the transmitter and receiver crystal oscillator circuits, respectively, may have to be changed. For frequencies below 110 kHz, these capacitors are 270 mmf. each. For frequencies of 110 kHz and above, the capacitors are 140 mmf. each.

CAUTION Turn power OFF before removing filters or transistors, as high transient currents may cause permanent damage to the transistors.

MAINTENANCE

Voltage values should be recorded after adjustment in order to establish reference values which will be useful when checking the apparatus. The readings

will remain fairly constant over an indefinite period unless a failure occurs. However, if transistors are changed, there may be considerable difference in these readings without the overall performance being affected.

Typical voltage and current values are given as follows. Voltages should be measured with VTVM. Readings may vary as much as $\pm 20\%$.

In the following paragraphs, the transmitter may be unblocked (transmitting) by closing the CARRIER START circuit in the case of HZM relaying, and by opening the CARRIER START circuit in the case of K-DAR and GCY relaying.

1. For D-C pin jack measurements with reference to B-, refer to Table 1.

2. For transistor D-C measurements with reference to B-, refer to Table 2.

3. For D-C bleeder measurements with reference to B-, refer to Table 3.

4. For typical RF signal measurements for receiver, refer to Table 4.

5. For typical RF signal measurements for transmitter, refer to Table 5.

6. Removal of Printed Circuit Board from Flexitest Case.

To remove the printed circuit board, unplug J-15 and J-16 located near the output filter. Loosen the two screws inside the case near the top. Loosen the slotted thumb screws at the lower end of the board and pull these screws out as far as they will extend. Also remove the receiver coaxial cable plug.

Pull board down so as to disengage the terminals, and lift out.

7. Removal of the Output Filter

After the printed board has been removed, remove the screws on the outside of the case at the bottom. Lift out filter and disconnect the coaxial cable.

8. Receiver Filters

* Fig. 13 shows typical receiver selectivity curves both RF and IF. If the filters are checked in a test

setup, it is necessary to use an accurate signal generator or preferably a signal generator and a frequency counter.

9. Minimum Test Equipment for Installation

- a. Milliammeter 0-25 ma DC.
 - b. 60-ohm 5-watt non-inductive resistor.
 - c. A-C Vacuum Tube Voltmeter (VTVM). Voltage range 0.003 to 30 volts, frequency range 60 Hz to 230-kHz, input impedance 7.5 megohms.
 - d. D-C Vacuum Tube Voltmeter (VTVM)
- Voltage Range: 0.15 to 300 volts
Input Impedance: 7.5 megohms

10. Desirable Test Equipment for Apparatus Maintenance

- a. All items listed in Sections 8 and 9.
 - b. Signal Generator
- Output Voltage: up to 8 volts
Frequency Range: 20-kHz. to 230-kHz.
- c. Oscilloscope
 - d. Ohmmeter
 - e. Capacitor checker
 - * f. Test harness (See Fig. 15)

APPLICATION

* 1. Receiver Selectivity (Fig. 12)

This shows a typical curve of the overall selectivity of the receiver under steady state conditions.

2. Transmitter Output Selectivity (Fig. 10)

Typical curves are shown so that approximate bandwidths for keying purposes can be determined for any carrier frequency between 30-kHz and 200-kHz.

* 3. Minimum Channel Spacing (Fig. 14)

This is a graph from which minimum channel spacing can be obtained provided the signal strength of the interfering transmitter and the sensitivity setting of the receiver are known. These can be obtained from calculations or by measurements.

For example, if the interfering transmitter voltage is measured (at the receiver) and found to be 2.5 volts, this would be 10-db down from 8 volts. This point can be located on the right hand column of the graph. Then, if the receiver sensitivity were set to operate on 0.8 volts or 20-db, this point would be located on the left hand column. A line could then be drawn through the two points as shown by the dotted line. The intersection of this line with the center line indicates the minimum channel spacing. In this case if the interfering signal is being keyed on-off, at 15 pps, the minimum spacing would be 2.5-kHz.

* 4. Supervisory Control Connections (Fig. 7)

When supervisory control is used with relaying, the supervisory control relay coil is connected in series with the RRH coil in place of the alarm relay. When supervisory control is used alone, a 1200-ohm resistor R3 is connected in series with the control relay coil by removing the jumper across R3, as shown in Fig. 7. In order to maintain proper mark space ratio, the relay bias current is adjusted for 9 milliamperes as indicated.

The receiver RF filter and the IF filter limits are shown on Fig. 15. Both filters are of the plug-in type and the test circuits with pin connections are shown at the top of each curve. The IF filter is divided into two separate sections. The selectivity shown is for each section, and the pin connections for each section are also shown in the test circuit sketch.

TABLE 1

D-C PIN JACK MEASUREMENTS WITH REFERENCE TO B-

Description	Jack	CONDITION A Tx-Blocked †† Rx-No Signal		CONDITION B Tx-Blocked Rx-With Signal		CONDITION C Tx-Unblocked Rx-No Signal	
		129 VDC	51 VDC	129 VDC	51 VDC	129 VDC	51 VDC
RF Input	J-2	0	0	0.3 V	0.3 V		
DC Q-1 Base	J-3	20 V	20 V	20 V	20 V		
DC R _x B+	J-4	20 V	20 V	20 V	20 V		
DC R _x Osc	J-5	7 V	7 V	7 V	7 V		
DC Q-5 Base	J-6	20 V	20 V	20 V	20 V		
B-	J-7						
DC-P1-E	J-8	110 V	32 V	110 V	32 V	110 V	32 V
DC-Q-7 Base	J-9	69 V	0 V	78 V	2.3 V	66 V	0.3 V
DC Q-7 Emit	J-10	70 V	1.0 V	78 V	1.4 V	66 V	1.0 V
DC T _x Osc	J-11	7 V	7 V	7 V	7 V	7 V	7 V
B+	J-12	129 V	51 V	129 V	51 V	129 V	51 V
DC Q-10 Base	J-13					18 V	18 V
DC Q-10 Emit	J-14					18 V	18 V
RF ma out	J-15					130 ma	130 ma
DC ma RRH and AL ARM				18 ma	18 ma		

†† Tx = transmitter, Rx = receiver

TABLE 2

TYPICAL TRANSISTOR DC MEASUREMENTS WITH REFERENCE TO B-

Transistor	Condition A Tx-Blocked Rx-No Signal (Volts)			Condition B Tx-Blocked Rx-With Signal (Volts)			Condition C Tx-Unblocked Rx-No Signal (Volts)		
	E†	B†	C†	E†	B†	C†	E†	B†	C†
Q-1	20.0	20.0	0.38	20.0	20.0	0.4			
Q-2	7	7.2	1.8	7	7.2	1.8			
Q-3	6.2	8.0	2	6.2	8	2.0			
Q-4	20.0	20.0	2.6	20.0	20.0	2.8			
Q-5	20.0	20.0	2.6	20.0	20.0	2.8			
Q-6									
129 VDC	110	110	129	115	114	129			
51 VDC	32	32	51	32	32	51			
Q-7									
129 VDC	70	68	129	78	80	86			
51 VDC	1.0	0	51	1.4	2.2	7.0			
Q-8	6.2	8	2	6.2	8	2	6.2	8	2
Q-9	7	7.2	1.8	7	7.2	1.8	7	7.2	1.8
Q-10††							18	18	0.4
Q-12††							0.27	0.20	50
Q-15††							0.27	0.20	50

† E-Emitter; B-Base; C-Collector.

†† With respect to term F on printed board.

TABLE 3

D-C BLEEDER MEASUREMENTS WITH REFERENCE TO B-

Measurement	129 VDC			51 VDC		
	A†	B†	C†	A†	B†	C†
Junction R-61 and R-62 (J-8)	110V	110V	110V	32V	32V	32V
Junction R-61 and R-27 (J-10)	70V	78V	66V	1.0V	1.4V	1.0V
Junction R-27 and R-60 (P1-P)	69V	77V	65V	0	0	0
Junction CR-8 and R-64 (P1-K)	58V	58V	58V	51V	51V	51V
Junction R-48 and R-47 (J-14)	—	—	18V	—	—	18V
Junction R-45 and R-47 (TP-9)	—	—	45V	—	—	51V
Junction R-45 and R-41 (TP-8)	—	—	98V	—	—	51V

† Conditions: A — Tx-Blocked, Rx-No Signal; B — Tx-Blocked, Rx-With Signal; C — Tx-Unblocked, Rx-No Signal.

TABLE 4
TYPICAL RF SIGNAL MEASUREMENTS FOR RECEIVER
(Made with 0.1 Volt at Terminal 5 of FL1)

Check Point	25 MV Sensitivity (Volts)	80 MV Sensitivity (Volts)	250 MV Sensitivity (Volts)
With Receiver Crystal Out			
FL1-5 to Gnd.	0.1	0.1	0.1
T1-1 to Gnd.	0.1	0.1	0.1
Q1-E to Gnd.	0.05	0.05	0.05
Q1-C to Gnd.	0.07	0.07	0.07
T3-1 to Gnd.	0.07	0.07	0.07
Q4-C to Gnd.	0.07	0.07	0.07
With Receiver Crystal In			
Q4-C to Gnd.	0.5	0.5	0.25
J6 to Gnd.	0.15	0.1	0.08
Q5-C to Gnd.	7.0	1.7	0.8
Q6-B to Gnd.	2.0	0.5	0.4
Q6-C to Gnd.	13.0	10.0	8.0
T4-1 to Gnd.	13.0	10.0	8.0
T4-3 to T4-4	4.5	3.5	2.5
J9 to J10 (DC)	0.74	0.75	0.65

TABLE 5

TYPICAL RF SIGNAL MEASUREMENTS FOR TRANSMITTER	
CHECK POINT	VOLTS
T5-1 to Gnd.	5.5
T5-3 to Gnd.	1.0
J13 to Gnd.	0.085
Q10-C to Gnd.	6.0
T6-2 to Gnd.	6.0
Q12-B to Gnd.	0.8
Q15-B to Gnd.	0.8
Q12-C to Gnd.	38.0
Q15-C to Gnd.	38.0
T7-5 to Gnd.	9.8
Output to Gnd.	8.0

ELECTRICAL PARTS LIST

CIRCUIT SYMBOL	FUNCTION	DESCRIPTION	MANUFACTURER'S DESIGNATION
<u>CAPACITORS</u>			
C-1	Rcvr. Bleeder	2.0 μ f, \pm 20%, 200 VDC, Paper	330C567 H11
†C-2	Rcvr. Osc. Feedback	140/270 μ f, \pm 20%, 500 VDC, Mica	330C566H43 * or 330C566H57
C-3	Rcvr. Osc. Bleeder Bypass	0.02 μ f, MRC, 600 VDC, Disc	330C569 H47
C-5	Q-6 Emitter Bypass	1.0 μ f, \pm 20%, 200 VDC Paper	330C567 H09
C-6	Rcvr. Rectifier Bypass	Same as C-5	
C-7	B- to B+ Bypass	2 μ f, \pm 10%, 600 VDC, Paper	14C9400 H18
C-8	B- to GND	1.0 μ f, \pm 10%, 1000 VDC, Paper	14C9400 H17
†C-9	Xmtr. Osc. Feedback	Same as C-2	
C-10	Xmtr. Osc.	Same as C-3	
C-11	Key Filter	0.1 μ f, \pm 20%, 200 VDC, Paper	330C567 H02
C-12	Q-10 Emitter Bypass	0.25 μ f, \pm 20%, 200 VDC, Paper	330C567 H05
C-13	Q-10 Bleeder Bypass	Same as C-12	
C-14	PA Base Bypass	Same as C-12	

† Note: 140 μ f for osc. freq. 110-kHz and above.
270 μ f for osc. freq. below 110-kHz.

CIRCUIT SYMBOL	FUNCTION	DESCRIPTION	MANUFACTURER'S DESIGNATION
CAPACITORS (Concluded)			
C-18	PA Bleeder	0.5 μf , $\pm 20\%$, Paper	330C567 H06
C-19	Output Filter Tuning	500 μf , Variable, Air	328C092 H01
C-20	Output Filter	390 μf , $\pm 5\%$, 2500 VDC, Mica	330C561 H15
C-21	Output Filter	680 μf , $\pm 5\%$, 2500 VDC, Mica	330C561 H21
C-22	Output Filter	1200 μf , $\pm 5\%$, 2500 VDC, Mica	330C561 H27
C-24	FL-2 Decoupling	Same as C-12	
C-25	Q-7 Emitter	12 mfd, $\pm 20\%$, 200 VDC	187A177 H01
C-26	Q-7 Base Bypass	.01 mfd, $\pm 10\%$, 100 VDC	763A219 H15
DIODES			
CR-1	Bridge Rectifier	General Purpose, 1N63	584C433 H02
CR-2	Bridge Rectifier	Same as CR-1	
CR-3	Bridge Rectifier	Same as CR-1	
CR-4	Bridge Rectifier	Same as CR-1	
CR-5	Q-10 Collector	Same as CR-1	
CR-6	Q-7 Base-Emitter	Type 1N457A	184A855 H07
CR-7	Voltage Regulator	Type 1N3686	185A212 H06
CR-8	Voltage Regulator	Type 1N1369	584C434 H05
CR-9	Q-7 Collector	Type 1N3811	185A089 H08
CR-10	Q-10 Emitter	Type 1N3028A	188A302 H14
CR-11	Voltage Regulator	Type 1N3024B	188A302 H12

ELECTRICAL PARTS LIST

CIRCUIT SYMBOL	FUNCTION	DESCRIPTION	MANUFACTURER'S DESIGNATION
<u>FUSE HOLDERS</u>			
FH-1	B-	For Type 3AGC Fuses	584C271 H02
FH-2	B+	Same as FH-1	
<u>FUSES</u>			
F-1	B-	3AGC 3/4 amp.	S#330C691 H12
F-2	B+	Same as F-1	
<u>FILTERS</u>			
FL-1	Rcvr. RF Bandpass	30 to 200 kHz Freq. to be specified by customer	
FL-2	Rcvr. IF Bandpass	20-kHz Fixed Freq.	
<u>CONNECTORS</u>			
J-1	Printed Circuit	Printed Circuit Female Plug	54-B-7125 H03
J-2	RF Input	UG-185-U	584C292 H07
J-3	Rcvr. Osc. Output	Terminal Studs	330C592 H01
J-4	Rcvr. Mixer-Amp Supply	Same as J-3	
J-5	Rcvr. Osc. Supply	Same as J-3	
J-6	Q-5 Base	Same as J-3	
J-7	B-	Same as J-3	
J-8	Q-6 Supply	Same as J-3	

ELECTRICAL PARTS LIST

CIRCUIT SYMBOL	FUNCTION	DESCRIPTION	MANUFACTURER'S DESIGNATION
<u>CONNECTORS (Concluded)</u>			
J-9	Q-7 Base	Same as J-3	
J-10	Q-7 Emitter	Same as J-3	
J-11	Xmtr. Osc. Supply	Same as J-3	
J-12	B+	Same as J-3	
J-13	Xmtr. Osc. Output	Same as J-3	
J-14	Q-10 Supply	Same as J-3	
J-15	Output Filter	Banana Tip Red	328C093 H01
J-16	Output Filter GND	Banana Tip Black	328C093 H02
P-1	Printed Circuit	Printed Circuit Male Plug	54-B-7126 H03
<u>INDUCTORS</u>			
L-1	Core and Coil Assembly	11 MH Total – 6 MH Tap (Part of FL-3)	329C450
L-2	Core and Coil Assembly	2.5 MH (Part of FL-3)	329C449
L-3	RF Choke	1.0 MH, 300 ma	R-300
L-4	RF Choke	Same as L-3	
<u>TRANSISTORS</u>			
Q-1	Rcvr. Mixer	Type 2N525	184A638H13
Q-2	Rcvr. Osc.	Type 2N414	184A638H14

ELECTRICAL PARTS LIST

CIRCUIT SYMBOL	FUNCTION	DESCRIPTION	MANUFACTURER'S DESIGNATION
<u>TRANSISTORS (Concluded)</u>			
Q-3	Rcvr. Osc.	Same as Q-2	
Q-4	Rcvr. IF	Same as Q-1	
Q-5	Rcvr. IF	Same as Q-1	
Q-6	Rcvr. IF	Type 2N498 or Type 2N657	184A638H15 184A638H15
Q-7	Rcvr. Output	Type 2N698	762A585H02
Q-8	Xmtr. Osc.	Same as Q-2	
Q-9	Xmtr. Osc.	Same as Q-2	
Q-10	Xmtr. Amp.	Same as Q-1	
Q-12	Xmtr. PA	Type 2N498 or Type 2N657	184A638H07 184A638H15
Q-15	Xmtr. PA	Same as Q-12	
<u>RESISTORS</u>			
R-1	Rec. Input	25 K, $\pm 20\%$, 1/4 W, Pot.	584C276 H23
R-2	Filter Matching	10 K, $\pm 10\%$, 1/2 W	330C595 H37
R-3	Filter Load	Same as R-2	
R-4	Rcvr. Osc.	1 K, $\pm 20\%$, 1/4 W, Pot.	584C276 H19
R-5	Rcvr. Voltage Divider	6.2 K, $\pm 5\%$, 1 W	330C666 H68
R-6	Q-2 Collector	1.2 K, $\pm 5\%$, 1/2 W	330C664 H51
R-8	Rcvr. Voltage Divider	15K $\pm 1\%$, 3W *	763A126H08 *
R-9	Rcvr. Voltage Divider	Same as R-8	

ELECTRICAL PARTS LIST

CIRCUIT SYMBOL	FUNCTION	DESCRIPTION	MANUFACTURER'S DESIGNATION
		<u>RESISTORS (Continued)</u>	
R-10	Q-2 Base	Same as R-2	
R-11	Q-2 Base	100 K, $\pm 5\%$, 1/2 W	330C665 H05
R-12	Q-3 Collector	Same as R-6	
R-13	Q-3 Emitter	390 Ohms, $\pm 5\%$, 1/2 W	330C664 H39
R-14	Q-3 Base	Same as R-2	
R-15	Q-3 Base	Same as R-11	
R-16	Rcvr. Osc. Bleeder	2.2 K, $\pm 10\%$, 1/2 W	330C595 H41
R-17	Rcvr. Osc. Bleeder	18 K, $\pm 10\%$, 2 W	330C597 H40
R-18	Rcvr. Osc.	9.1 K, $\pm 5\%$, 1/2 W	330C664 H72
R-19	Q-4 Bias	100 Ohms, $\pm 5\%$, 1/2 W	330C664 H25
R-20	Q-4 Bias	Same as R-2	
R-21	Q-5 Bias	150 Ohms, $\pm 5\%$, 1/2W	330C664 H29
R-22	Q-5 Bias	Same as R-2	
R-23	Q-6 Bias	330 Ohms, $\pm 5\%$, 1/2 W	330C664 H37
R-24	Q-6 Bias	Same as R-2	
R-25	Q-6 Emitter	Same as R-19	
R-26	Q-7 Base	Same as R-6	
R-27	Q-7 Bias	20 Ohms, $\pm 5\%$, 1/2 W	330C664 H08
R-28	Xmtr. Osc. Bleeder	Same as R-18	
R-29	Xmtr. Osc. Bleeder	Same as R-17	
R-30	Xmtr. Osc. Bleeder	Same as R-16	

ELECTRICAL PARTS LIST

CIRCUIT SYMBOL	FUNCTION	DESCRIPTION	MANUFACTURER'S DESIGNATION
		<u>RESISTORS (Continued)</u>	
R-31	Q-8 Base	Same as R-11	
R-32	Q-8 Base	Same as R-2	
R-33	Q-8 Emitter	Same as R-13	
R-34	Q-8 Collector	Same as R-6	
R-35	Q-9 Base	Same as R-11	
R-36	Q-9 Base	Same as R-2	
R-37	Q-9 Collector	Same as R-6	
R-38	Key Filter	Same as R-23	
R-39	Buffer Voltage Divider	36 K, $\pm 5\%$, 2 W	330C668 H86
R-40	Buffer Voltage Divider	Same as R-39	
R-41	Buffer Voltage Divider	Same as R-2	
R-42	Xmtr. Osc. Output	Same as R-4	
R-43	Q-10 Bias	Same as R-23	
R-44	Q-10 Bias	33 K, $\pm 5\%$, 1/2 W	330C664 H85
R-45	Buffer Voltage Divider	15 K, $\pm 10\%$, 1 W	330C596 H39
R-47	Buffer Voltage Divider	6.8 K, $\pm 5\%$, 1/2 W	330C664 H69
R-48	Buffer Voltage Divider	15 K, $\pm 5\%$, 1/2 W	330C664 H77
R-49	PA Bias	27 K, $\pm 5\%$, 2 W	330C668 H83

ELECTRICAL PARTS LIST

CIRCUIT SYMBOL	FUNCTION	DESCRIPTION	MANUFACTURER'S DESIGNATION
		<u>RESISTORS (Concluded)</u>	
R-50	Xmtr. PA	Same as R-19	
R-52	Q-12 Emitter	10 Ohms, $\pm 5\%$, 1/2 W	330C664 H01
R-55	Q-15 Emitter	Same as R-52	
R-59	Xmtr. Bleeder	47 Ohms, $\pm 10\%$, 1/2 W	330C595 H09
R-60	Recvr. Bleeder	1 K, $\pm 5\%$, 25 W	584C416 H57
R-61	Recvr. Bleeder	600 Ohms, $\pm 5\%$, 25 W	584C416 H47
R-62	Recvr. Bleeder	350 Ohms, $\pm 5\%$, 25 W	584C416 H52
R-64	Xmtr. Bleeder	1200 Ohms, $\pm 5\%$, 25 W	584C416 H64
R-66	T-7 Load	560 Ohms, $\pm 5\%$, 2 W	330C668 H43
R-67	Xmtr. Blocking	10 Ohms, $\pm 5\%$, 2 W	330C668 H01
R-68	Xmtr. Blocking	10 K, $\pm 10\%$, 10 W	330C577 H01
R-69	Q-10 Emitter	Same as R-19	
R-70	FL2 Decoupling	470 Ohms, $\pm 10\%$, 1/2 W	330C595 H21
R-71	Q-4 Emitter	Determined in test *	
R-72	Q-5 Emitter	Determined in test *	
R-73	Q-5 Base	220 Ohms, $\pm 10\%$, 1/2 W *	187A641H11
R-74	Q-4 Base	1K, $\pm 5\%$, 1/2 W *	184A763H27
R-75	Q-4 Collector	22 K, $\pm 10\%$, 1/2 W	330C595 H41
R-76	Q-5 Collector	Same as R-75	

ELECTRICAL PARTS LIST

CIRCUIT SYMBOL	FUNCTION	DESCRIPTION	MANUFACTURER'S DESIGNATION
<u>TRANSFORMERS</u>			
T-1	Rcvr. Input	Impedance Ratio 10 K; 10K	S#1962798, L-633005
T-2	Rcvr. Osc.	Impedance Ratio 10 K: 400 ohms	S#1962797, L-633003
T-3	Rcvr. Mixer	Impedance Ratio 25 K: 300 ohms	S#1962697, L-592171
T-4	IF Output	Impedance Ratio 4 K: 500 ohms	S#1962693, L-592289
T-5	Xmtr. Osc.	Same as T-2	
T-6	Xmtr. Buffer	Impedance Ratio 10 K: 400 ohms CT	S#1962698, L-592170
T-7	Xmtr. Output	Impedance Ratio 1930: 60	S#1962694, L-633000
<u>TEST POINTS</u>			
TP-1	R-5	Terminal studs	330C592 H02
TP-2	R-8	Same as TP-1	
TP-3	R-17	Same as TP-1	
TP-4	R-18	Same as TP-1	
TP-5	R-28	Same as TP-1	
TP-6	R-39 & R-40	Same as TP-1	
TP-7	R-41	Same as TP-1	
TP-8	R-45	Same as TP-1	
TP-9	R-47	Same as TP-1	

ELECTRICAL PARTS LIST

CIRCUIT SYMBOL	FUNCTION	DESCRIPTION	MANUFACTURER'S DESIGNATION
<u>SOCKETS</u>			
X-1	FL-1	Octal	330C689 H01
X-2	FL-2	Same as X-1	
X-4	Rear Mounted Voice Adaptor	Same as X-1	
XY-1	Rec. Y-1	Crystal	584C606 H01
XY-2	Xmtr. Y-2	Same as XY-1	
<u>CRYSTALS</u>			
Y-1	Rcvr. Osc.	Specify Channel Freq. Plus 20-kHz.	328C083
Y-2	Xmtr. Osc.	Specify Freq. Same as Channel Frequency	328C083
<u>RESERVE SIGNAL DETECTOR</u> (S*470D167G02)			
R-1	Resistor, Level Control	200 K, 2 W, Pot.	184A086H27
R-2	Resistor, Limiting	2000 ohms, 2" tube.	1267296
S-1	Test Switch	SPST Normally Open	327C854 H01

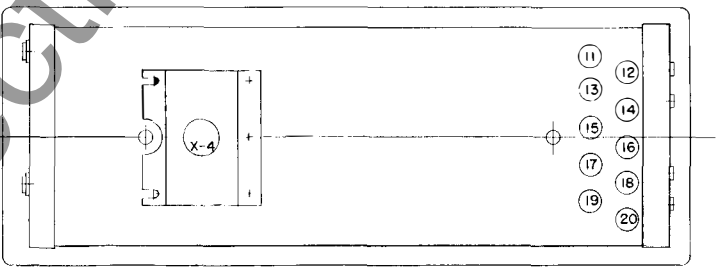
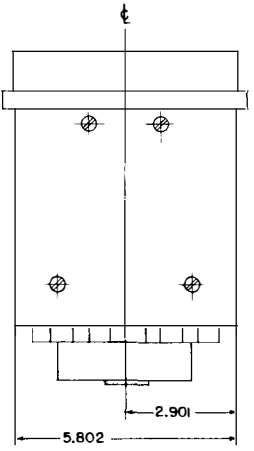
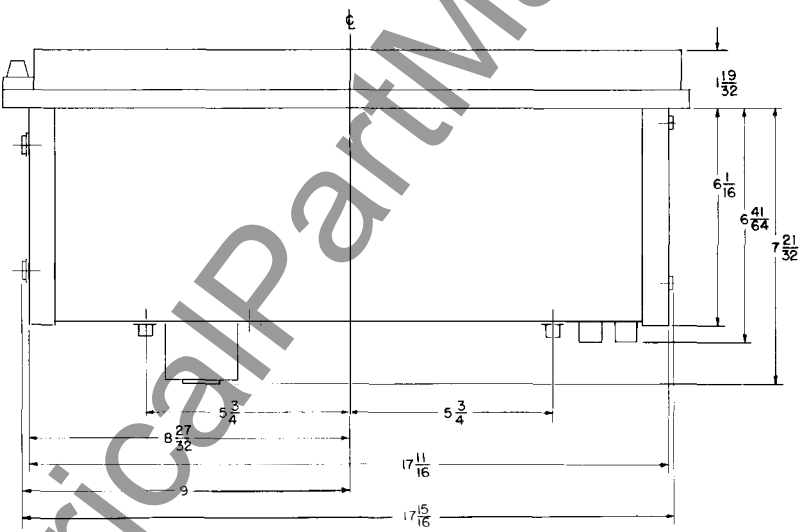
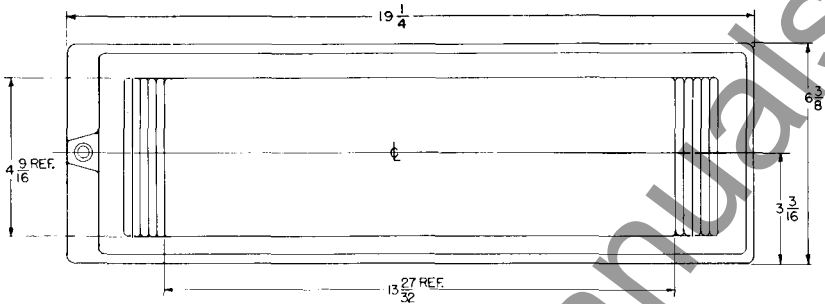
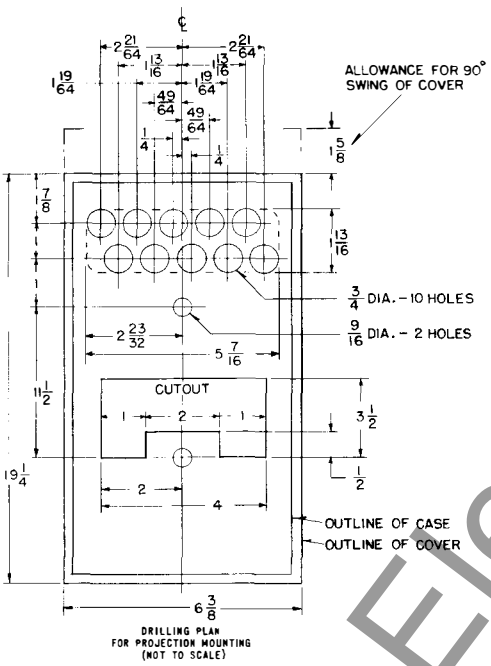
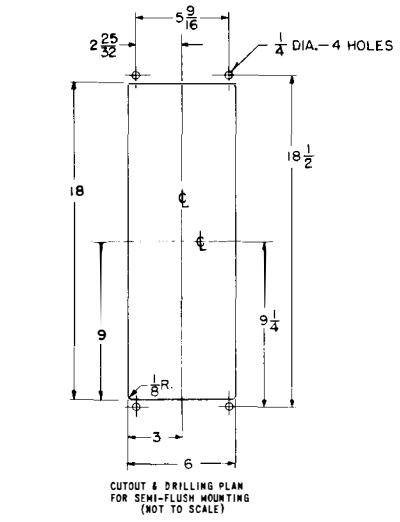
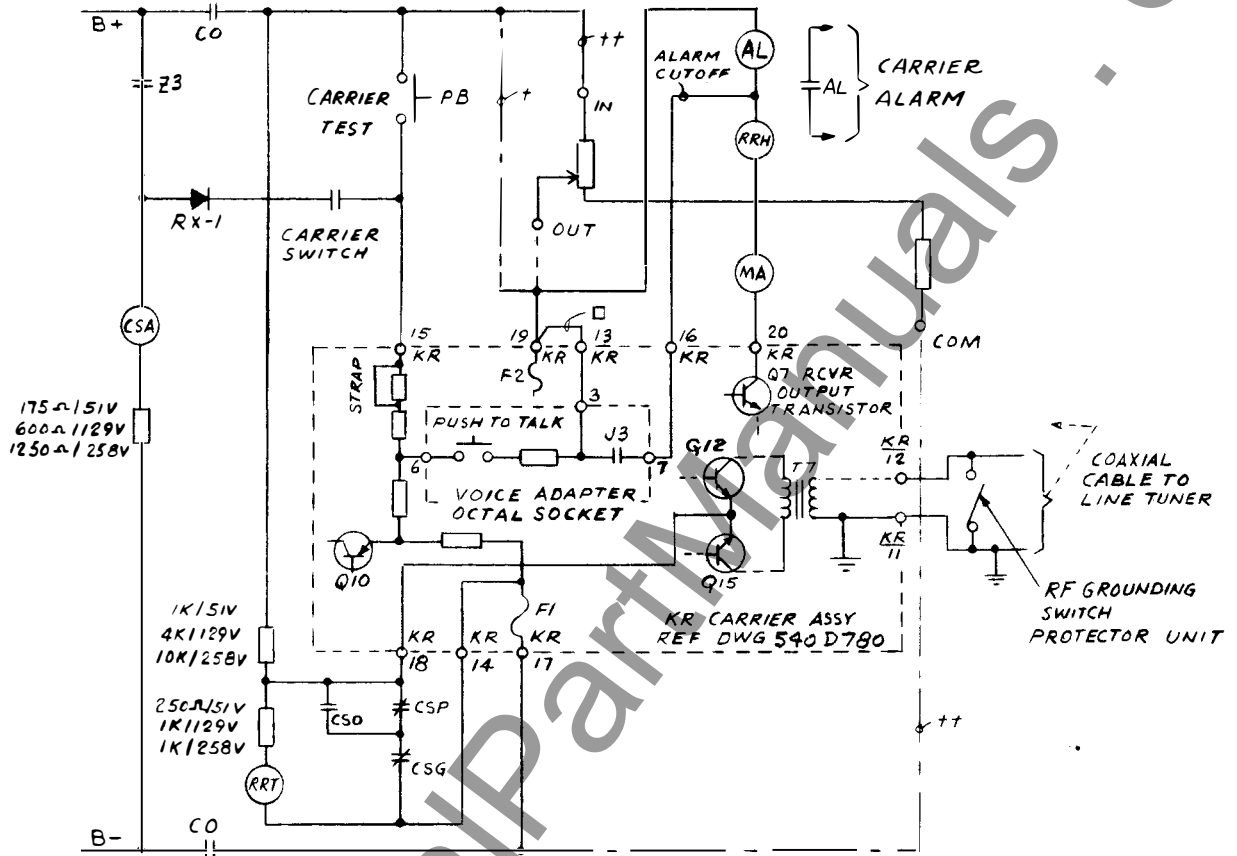

Fig. 1 Outline Drawing, (Flexitest Case) (540D753)

TYPE KR CARRIER SET



REQUIREMENTS FOR HZ/HZM RELAYING			
SUPPLY VOLTAGE	CARRIER START	CARRIER STOP	STRAP
51VDC	+51V, 7MA	+28V	IN
129VDC	+129V, 8MA	+40V	IN
258VDC	+258V, 8MA	+40V	OUT

NOTES

- + FOR 51 & 129 VDC SUPPLY.
- ++ FOR 258VDC SUPPLY USE 330C191H01 RESISTOR UNIT REF DWG 223 B497
- FOR SUPERVISORY CONTROL PREFERENCE CONTACTS.

KR RELAYING TRANSMITTER / RECV EXTERNAL CONNECTIONS

TERMINAL - CONNECTION

- 11 GROUND
- 12 COAXIAL CABLE
- 13 SUPERVISORY PREFERENCE CONTACT
- 14 CARRIER STOP B- RETURN
- 15 CARRIER START (POSITIVE)
- 16 ALARM CUTOFF FOR COMMUNICATIONS
- 17 B MINUS
- 18 CARRIER STOP (HZ/HZM)
- 19 B PLUS
- 20 RELAY COIL

Fig. 3- Relaying Control Circuits - HZ/HZM (Dwg. 1-329C704)

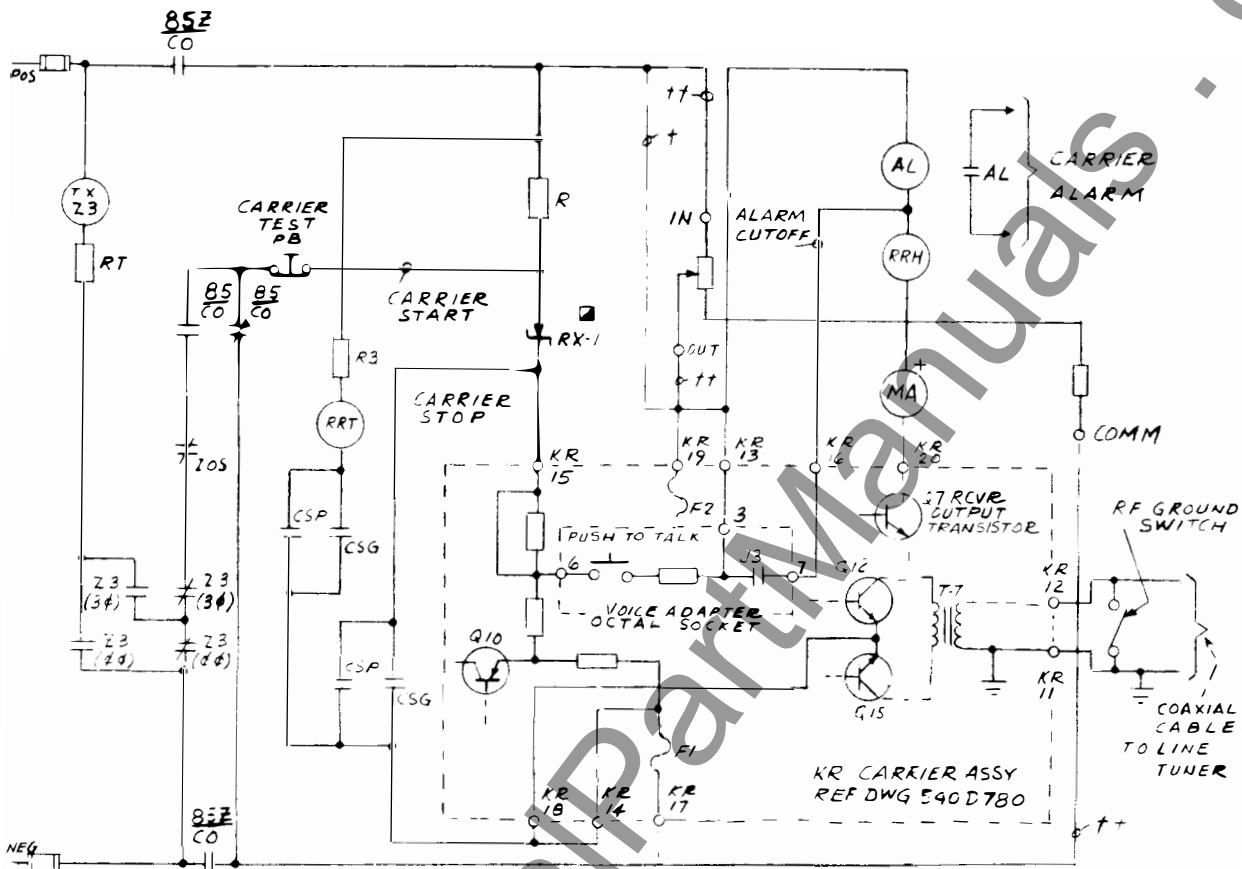

REQUIREMENTS FOR K DAR RELAYING

SUPPLY VOLTAGE	CARRIER START	CARRIER STOP	R
51 VDC	+ 37V 7MA	0 VOLTS	2K
129 VDC	+ 100V 5 MA	0 VOLTS	3.75K
258 VDC	+ 100V 5 MA	0 VOLTS	19K

NOTES

KR RELAYING TRANSMITTER /
 RECV EXTERNAL CONNECTIONS
 TERMINAL CONNECTION

- 11 GROUND
- 12 COAXIAL CABLE
- 13 SUPERVISORY PREFERENCE CONTACT
- 14 CARRIER STOP B- RETURN
- 15 CARRIER START (POSITIVE)
- 16 ALARM CUTOFF FOR COMMUNICATIONS
- 17 E MINUS
- 18 CARRIER STOP (HZ/HZM)
- 19 B PLUS
- 20 RELAY COIL

- ☐ TYPE IN3551 IN CARRIER ASSY. RELAY
- + FOR 51 & 129 VDC SUPPLY
- ++ FOR 258VDC SUPPLY USE 330C191H01 RESISTOR UNIT REF DWG 223.B.197

Fig. 4-Relaying Control Circuits-K-Dar (Dwg. 3-329C704)

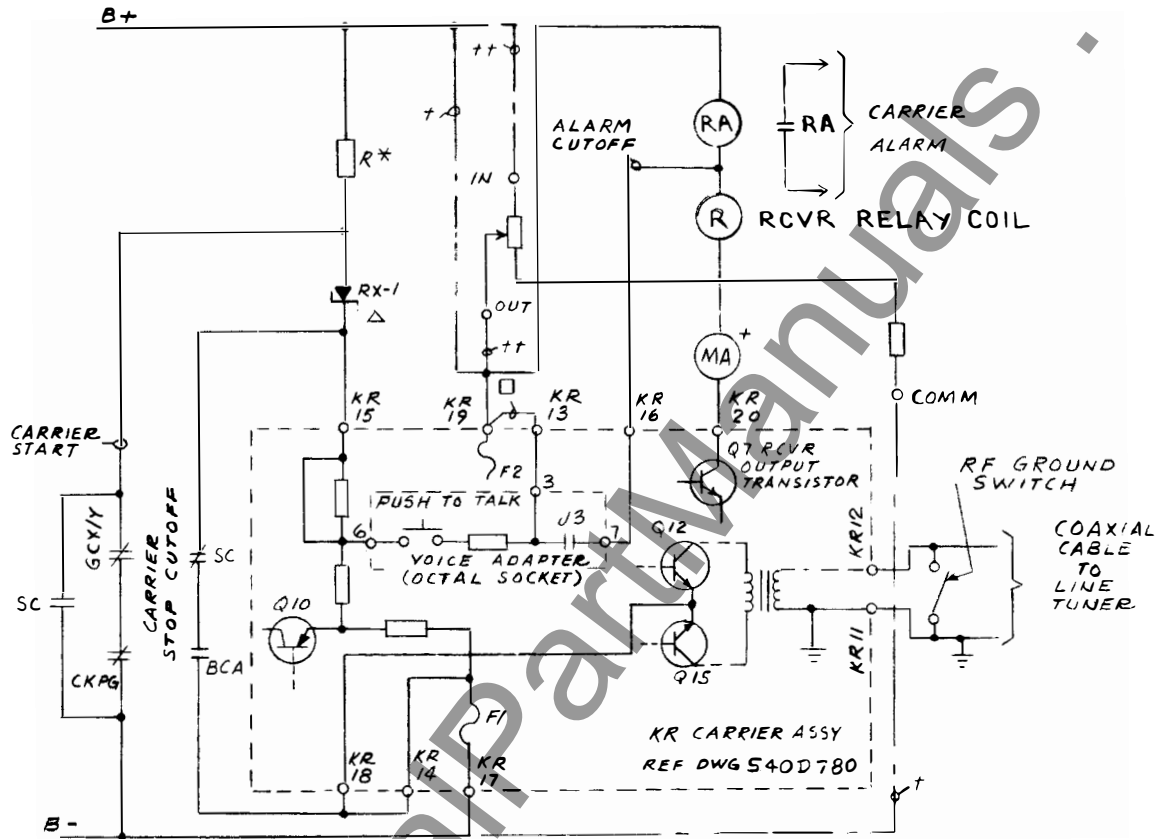

REQUIREMENTS FOR GCX/GCY RELAYING

SUPPLY VOLTAGE	CARRIER START	CARRIER STOP	R
51 VDC	+37V, 7MA	0 VOLTS	2K
129 VDC	+100V, 8MA	0 VOLTS	3.75K
258 VDC	+100V, 8MA	0 VOLTS	19.K

KR RELAYING TRANSMITTER /
RCVR. EXTERNAL CONNECTIONS
TERMINAL-CONNECTION

- 11. GROUND
- 12. COAXIAL CABLE
- 13. SUPERVISORY PREFERENCE CONTACT
- 14. CARRIER STOP B- RETURN
- 15. CARRIER START (POSITIVE)
- 16. ALARM CUTOFF FOR COMMUNICATIONS
- 17. B MINUS
- 18. CARRIER STOP (HZ/HZM)
- 19. B PLUS
- 20. RELAY COIL

NOTES

- * FOR "R" USE OHMITE VITREOUS ENAMELED DIVIDOHM ADJUSTABLE 4K OR 20K 25W RESISTOR. CONNECT & ADJUST FOR VALUES SHOWN
- △ TYPE IN 3051
- + FOR 51 & 129 VDC SUPPLY
- ++ FOR 258VDC SUPPLY USE 330C191H01 RESISTOR UNIT REF DWG 223B497
- FOR SUPERVISORY CONTROL PREFERENCE CONTACTS

Fig. 5. Relaying Control Circuits-GCX/GCY (Dwg. 2-329C704)

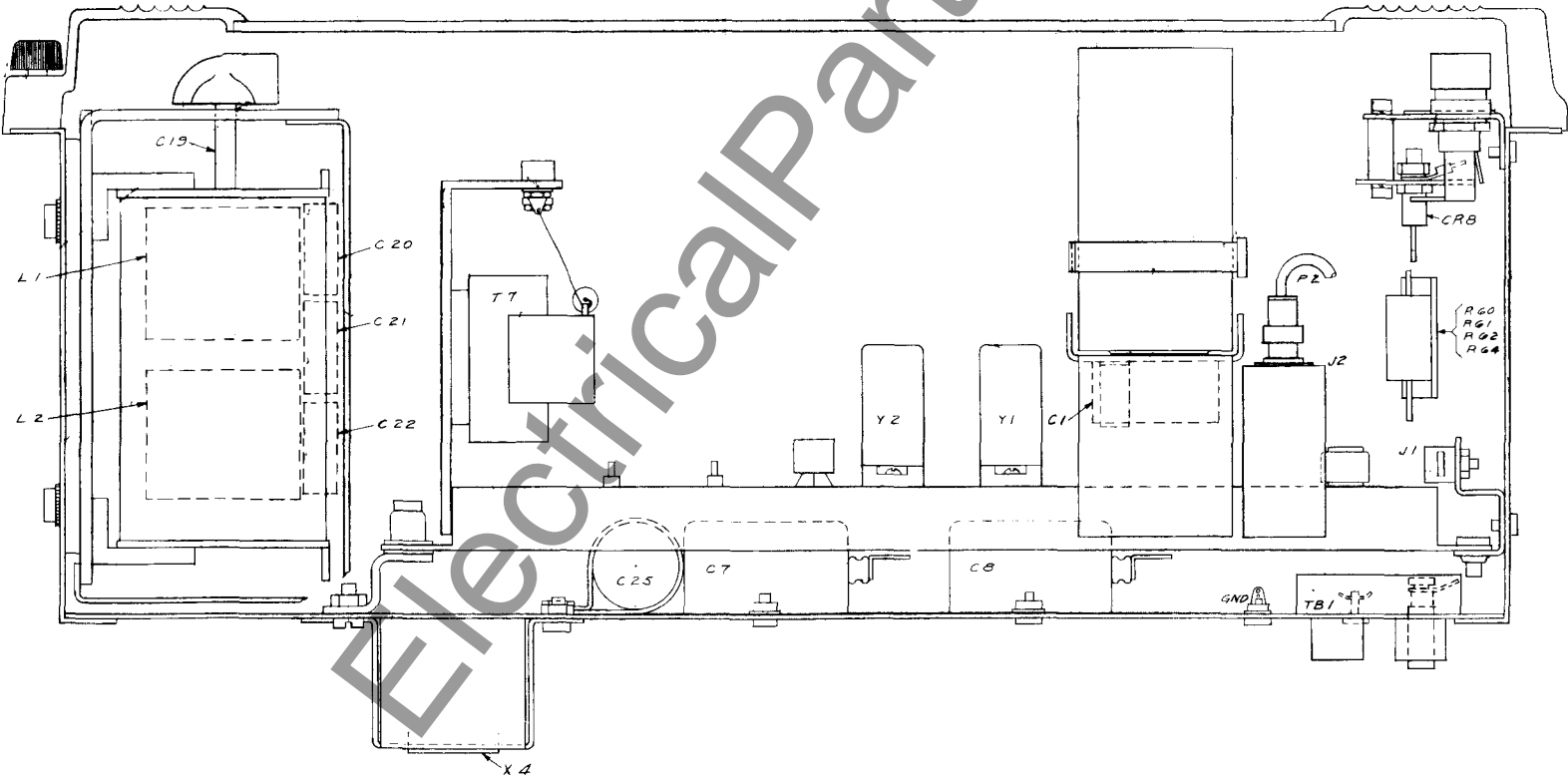
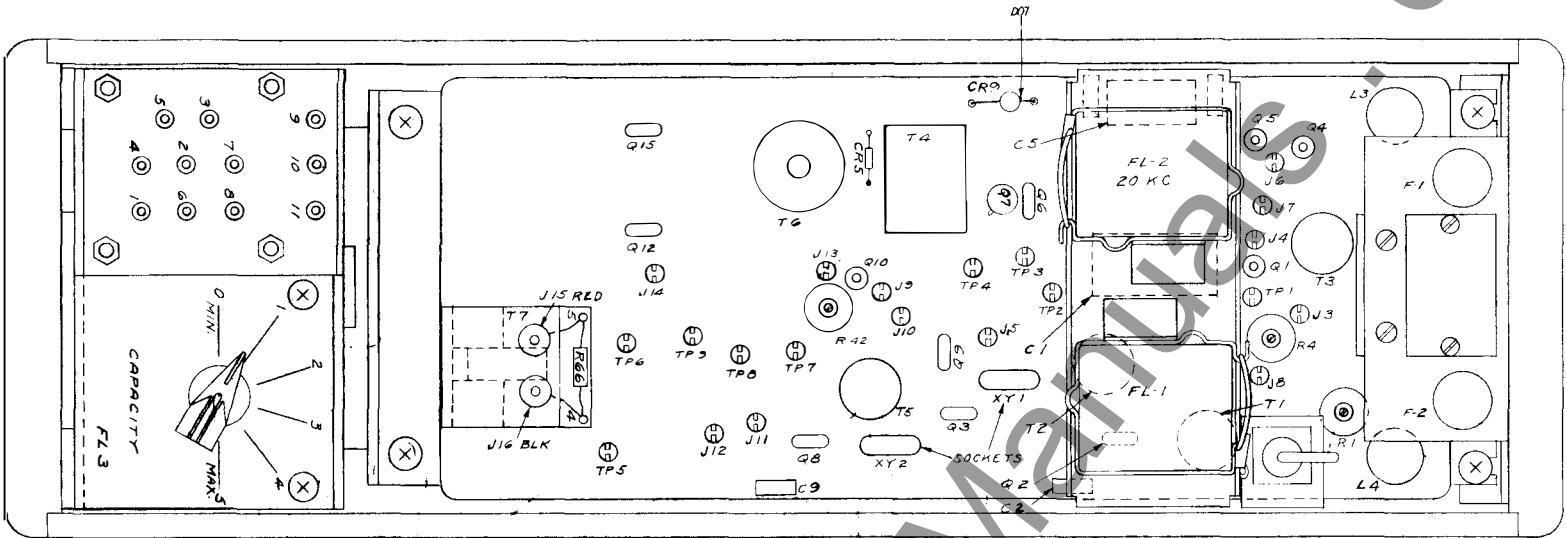
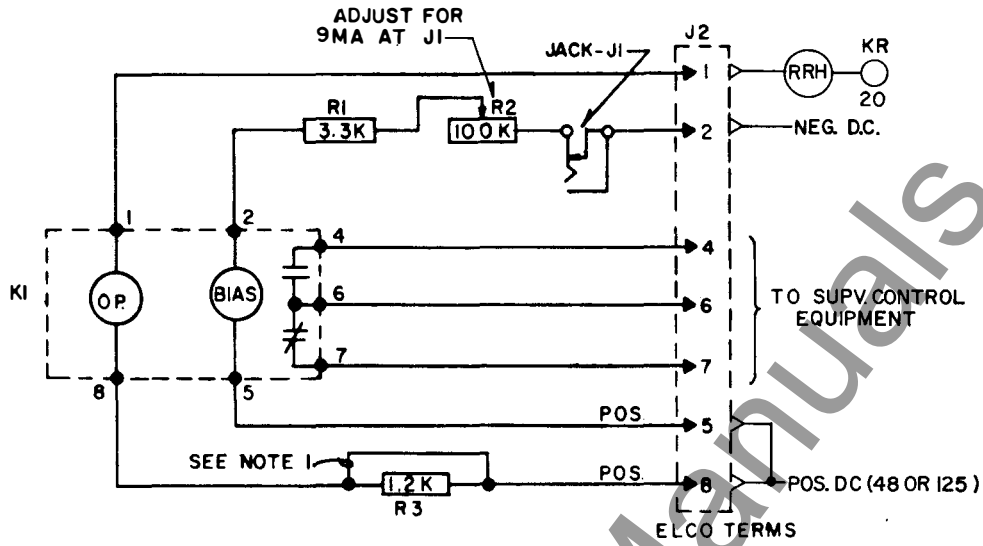
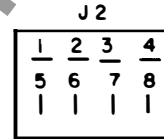

Fig. 6. Component Location (Dwg. 540D781)



NOTES:

1. REMOVE FOR KR CARRIER PLUS SUPV. CONTROL WITHOUT RELAYING.
2. POLARITY SHOWN CLOSES CONTACT BETWEEN TERMINALS 4 & 6.



AS VIEWED FROM REAR OF PANEL

629A552

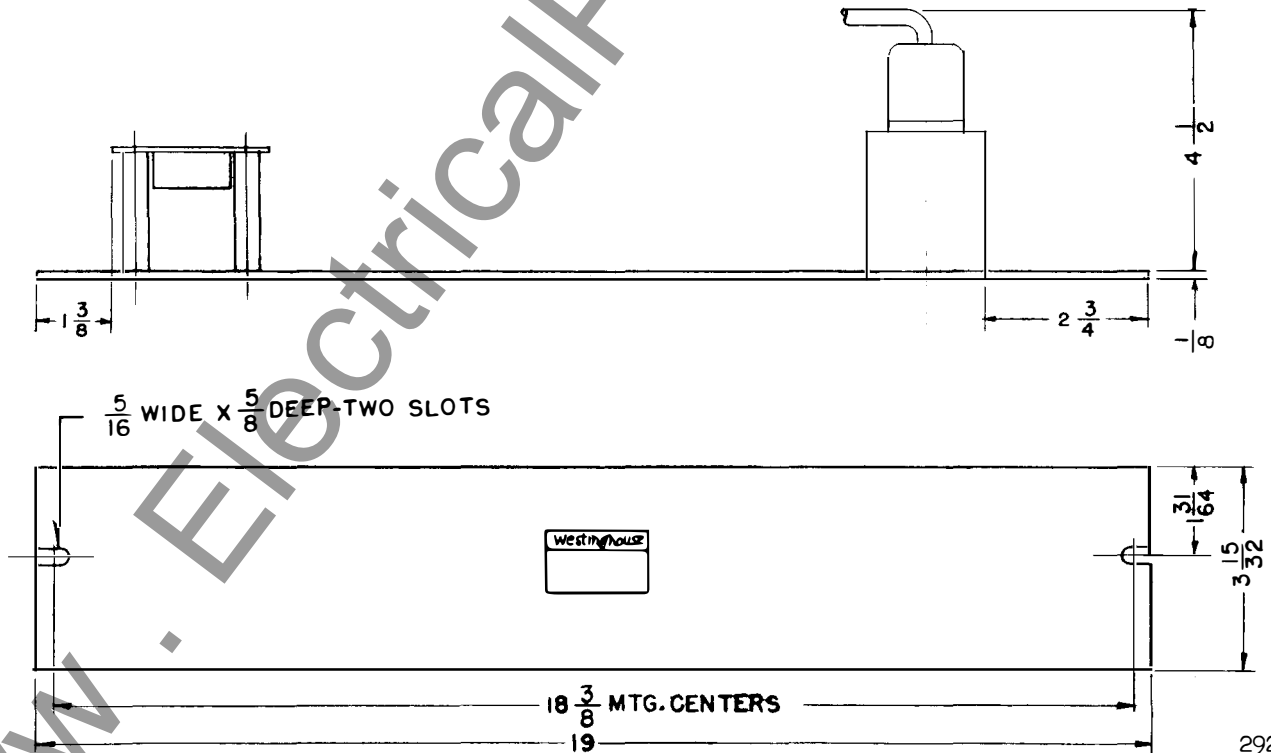

292B991

Fig. 7. Supervisory Control Auxiliary Relay Connections (Dwg. 629A552) and Outline (Dwg. 292B991).

**CONNECTIONS FOR 48-250 VOLT SERVICE AND
SUPERVISORY CONTROL APPLICATION**
(CHANGES FROM JUMPERS SHOWN ON INTERNAL SCHEMATIC, FIG.2)

250-VOLT OPERATION

FOR A 250 VOLT SUPPLY, RESISTOR UNIT 330C191H01 IS USED AS SHOWN ON APPLICATION DRAWING 329C704

FOR HZ/HZM OPERATION, THE JUMPER HAS BEEN REMOVED FROM TP-6 TO TP-7. (NOT REMOVED FOR K-DAR RELAYING).

RESISTOR UNIT SCHEMATIC:

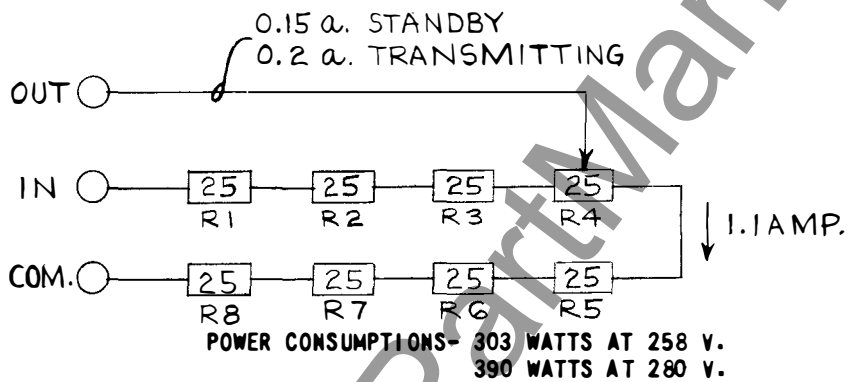

NOTE: KR SUPPLY VOLTAGE WILL BE APPROXIMATELY 144 VOLTS UNDER STANDBY CONDITION WHEN BATTERY VOLTAGE IS 280 VOLTS.

125-VOLT HZ/HZM OPERATION

JUMPER TP-7 AND TP-8 IS REMOVED.

48 VOLT OPERATION

ON PRINTED CIRCUIT BOARD ADDITIONAL JUMPERS ARE CONNECTED AS FOLLOWS:

- BETWEEN TP8 AND TP9
- BETWEEN TP5 AND J12
- BETWEEN TP1 AND TP2
- BETWEEN TP3 AND TP4

IN THE FT CASE, JUMPERS ARE CONNECTED ACROSS R60 AND R64, AND THE CONNECTION BETWEEN R64 AND DIODE CR8 IS REMOVED.

IN ADDITION, FOR 48-VOLT SUPERVISORY CONTROL, R59 IS CONNECTED INTO THE CIRCUIT.

Fig. 8. Connections, 48-250 Volts and Supervisory Control (Dwg. 407C971)

TRANSMITTER OUTPUT FILTER FL-3 CONNECTIONS

<u>LINE</u>	<u>FREQUENCY RANGE</u>	<u>COIL</u>	<u>COIL CONNECTIONS</u>	<u>PARALLEL CAPACITOR CONNECTIONS</u> Δ
1	27.7 KHZ-30.0 KHZ	L-1	(1-5) (3-6)	6-8-9-10-11
2	29.8 KHZ-33.1 KHZ	L-1	(1-5) (3-6)	6-8-10-11
3	31.8 KHZ-36.0 KHZ	L-1	(1-5) (3-6)	6-8-9-11
4	35.4 KHZ-39.0 KHZ	L-1	(1-5) (3-6)	6-8-11
5	38.0 KHZ-41.0 KHZ	L-1	(1-2) (3-6)	6-8-9-10-11
6	40.3 KHZ-45.0 KHZ	L-1	(1-2) (3-6)	6-8-10-11
7	43.0 KHZ-49.0 KHZ	L-1	(1-2) (3-6)	6-8-9-11
8	47.7 KHZ-56.0 KHZ	L-1	(1-2) (3-6)	6-8-11
9	49.5 KHZ-58.5 KHZ	L-1	(1-2) (3-6)	6-8-9-10
10	57.0 KHZ-72.3 KHZ	L-1	(1-2) (3-6)	6-8-10
11	67.0 KHZ-76.0 KHZ	L-2	(1-4) (6-7)	6-8-9-11
12	75.0 KHZ-88.0 KHZ	L-2	(1-4) (6-7)	6-8-11
13	77.5 KHZ-93.0 KHZ	L-2	(1-4) (6-7)	6-8-9-10
14	89.3 KHZ-114.5 KHZ	L-2	(1-4) (6-7)	6-8-10
15	102.7 KHZ-147.0 KHZ	L-2	(1-4) (6-7)	6-8-9
16	136.6 KHZ-210.0 KHZ	L-2	(1-4) (6-7)	6-8

Δ =CONNECTION FROM 6 TO 8 IS MADE BENEATH TERMINAL PLATE ON ALL SETS AT THE FACTORY.

Fig. 9. Connections - Output Filter (Dwg. 149A420)

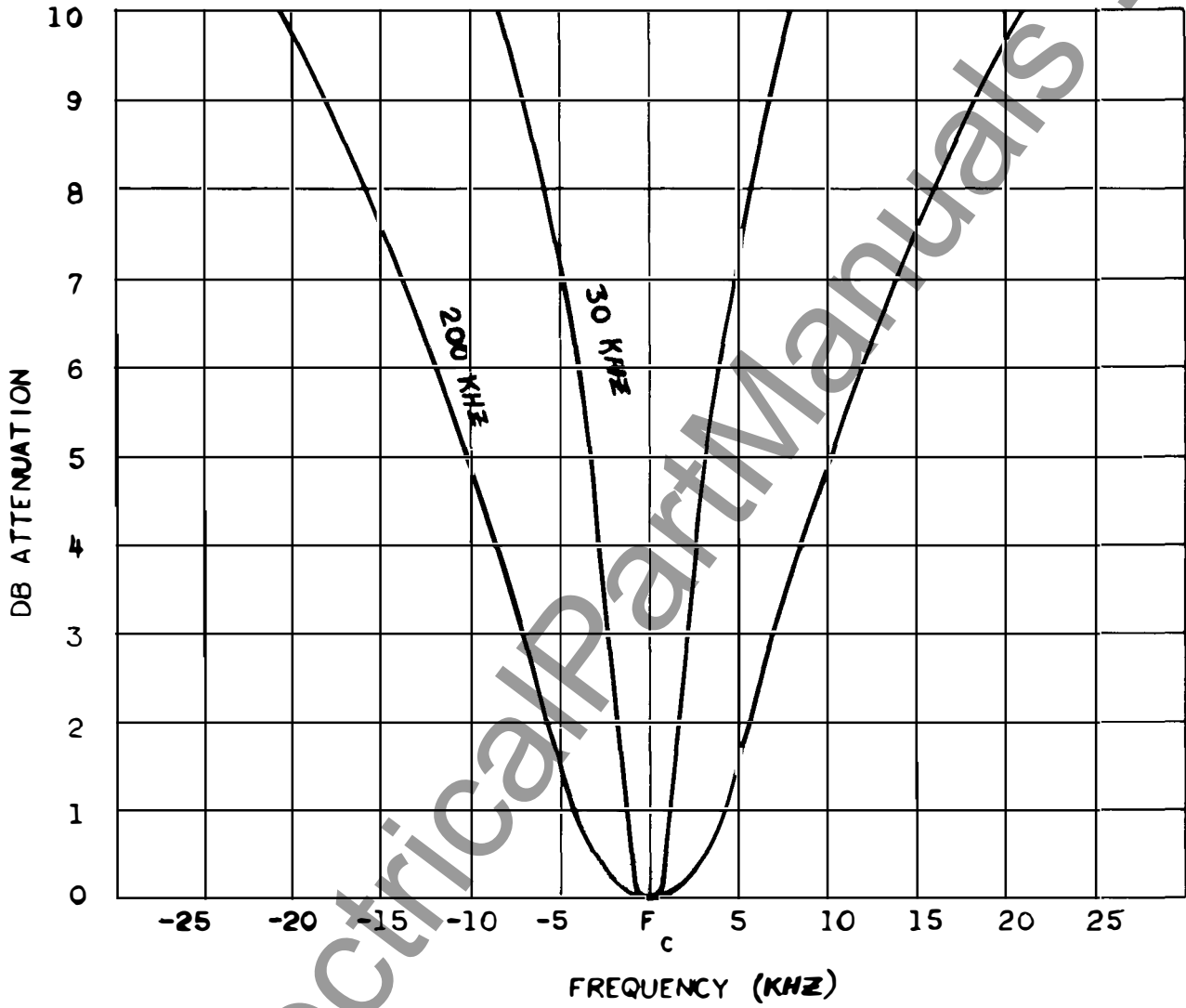

Fig. 10. Transmitter Output Filter Selectivity (Dwg. 377996)

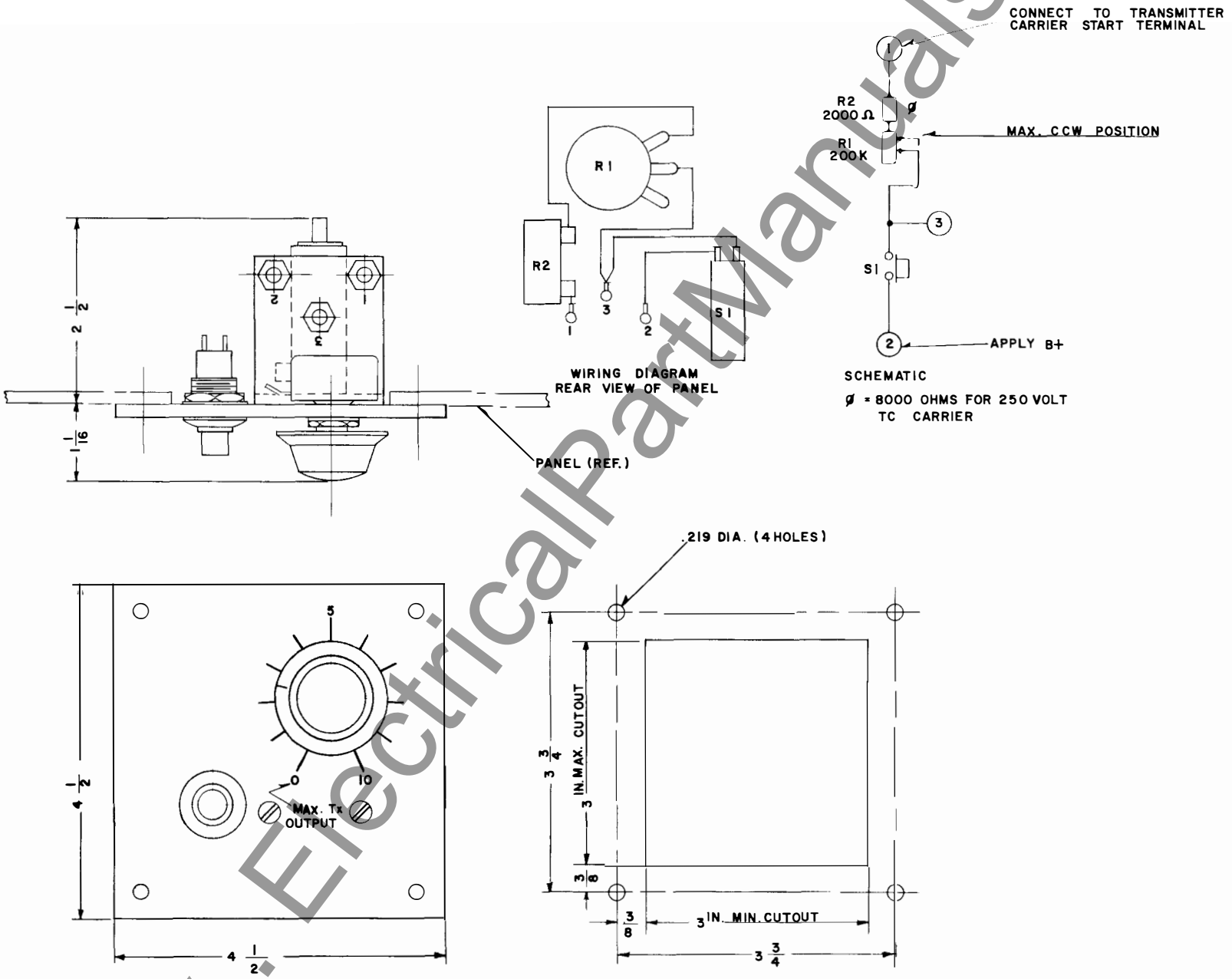

Fig. 11. Reserve Signal Detector Outline (Dwg. 329C703)

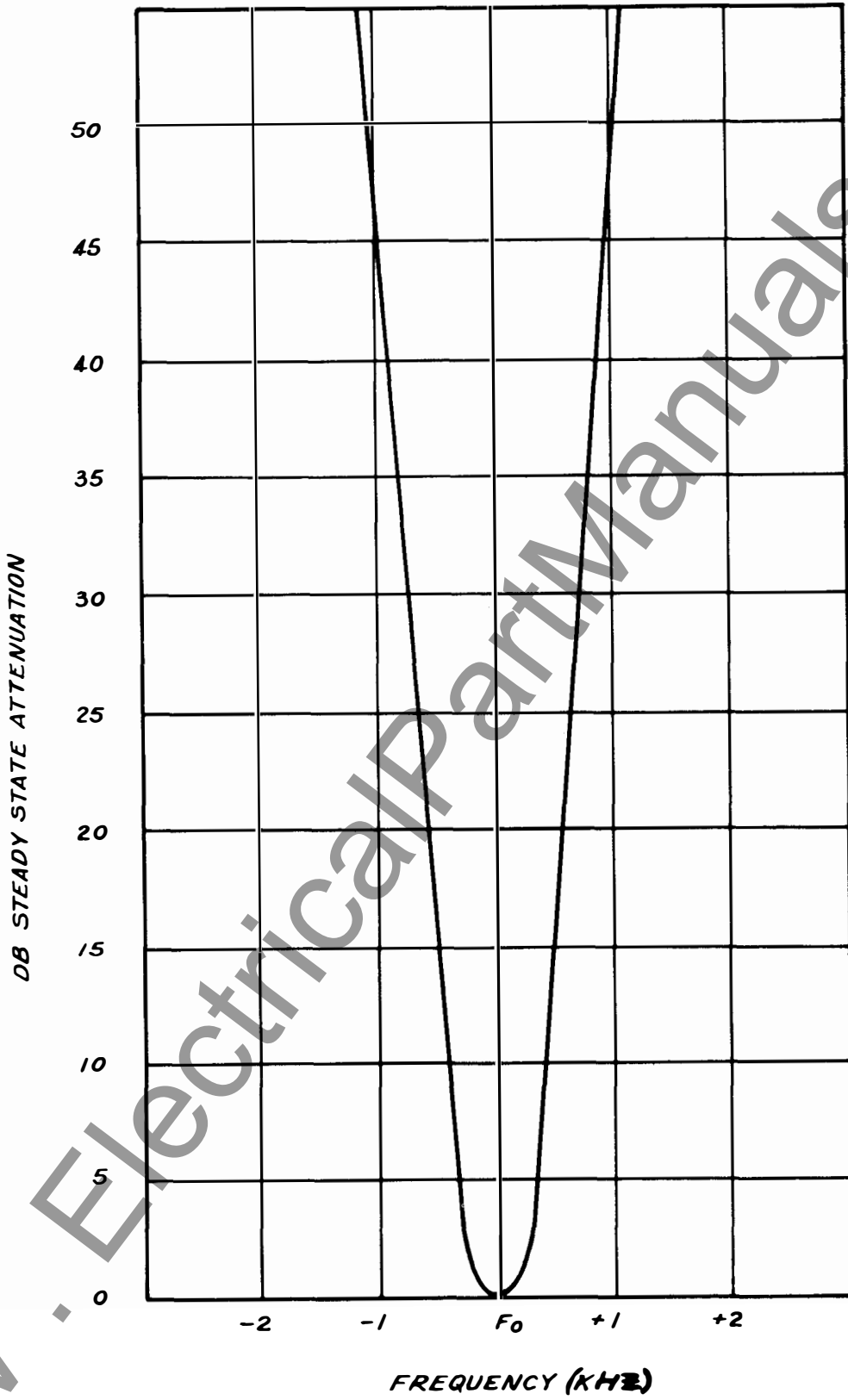
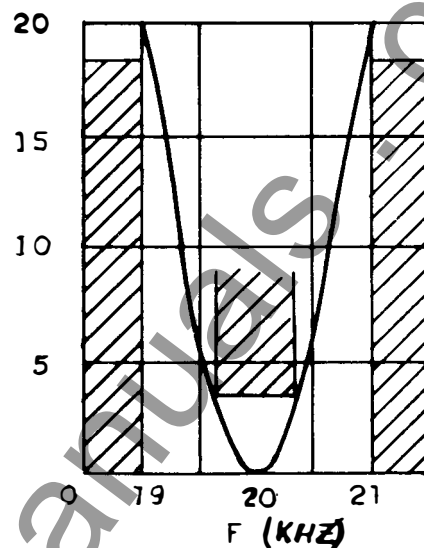
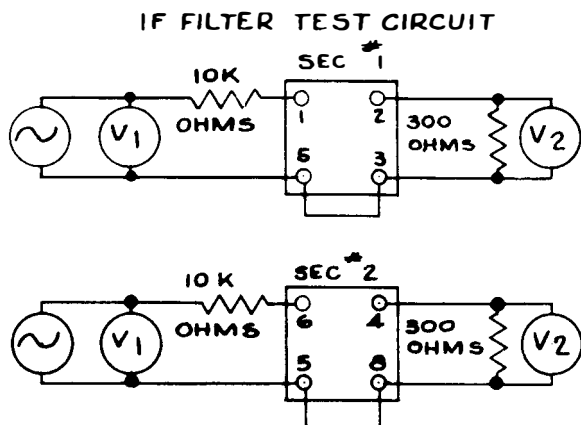

Fig. 12. Receiver Selectivity (Curve #377993)



Each section of FL-2 requirement with typical selectivity curve. Insertion loss 26 DB max. Including matching resistor.

FOR BOTH CURVES

$$DB = 20 \log \frac{V_1}{V_2}$$

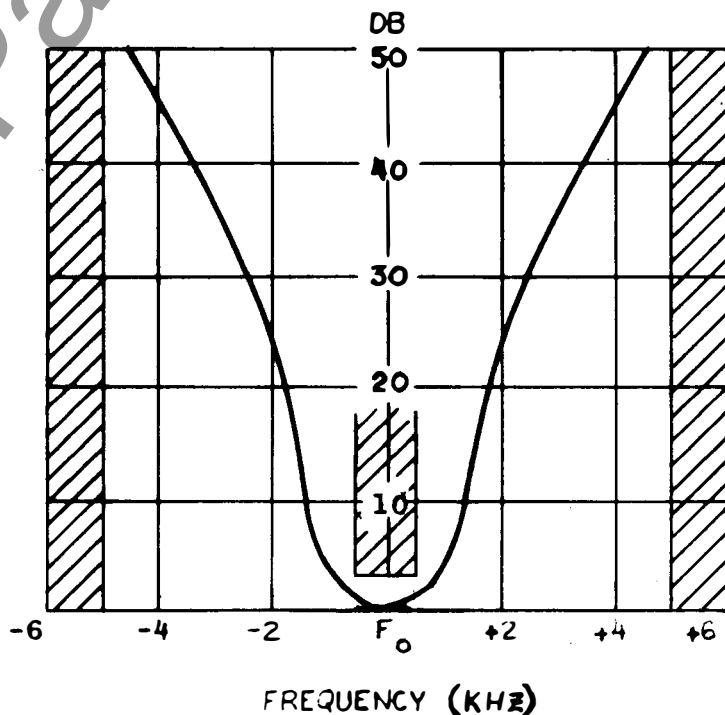
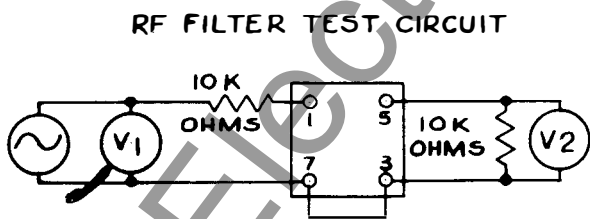

FL-1 Requirement with typical selectivity curve at 120 KHZ. Insertion loss 18 DB max. Including matching resistor.

Fig. 13. Receiver Filter Limits (Curve #377995)

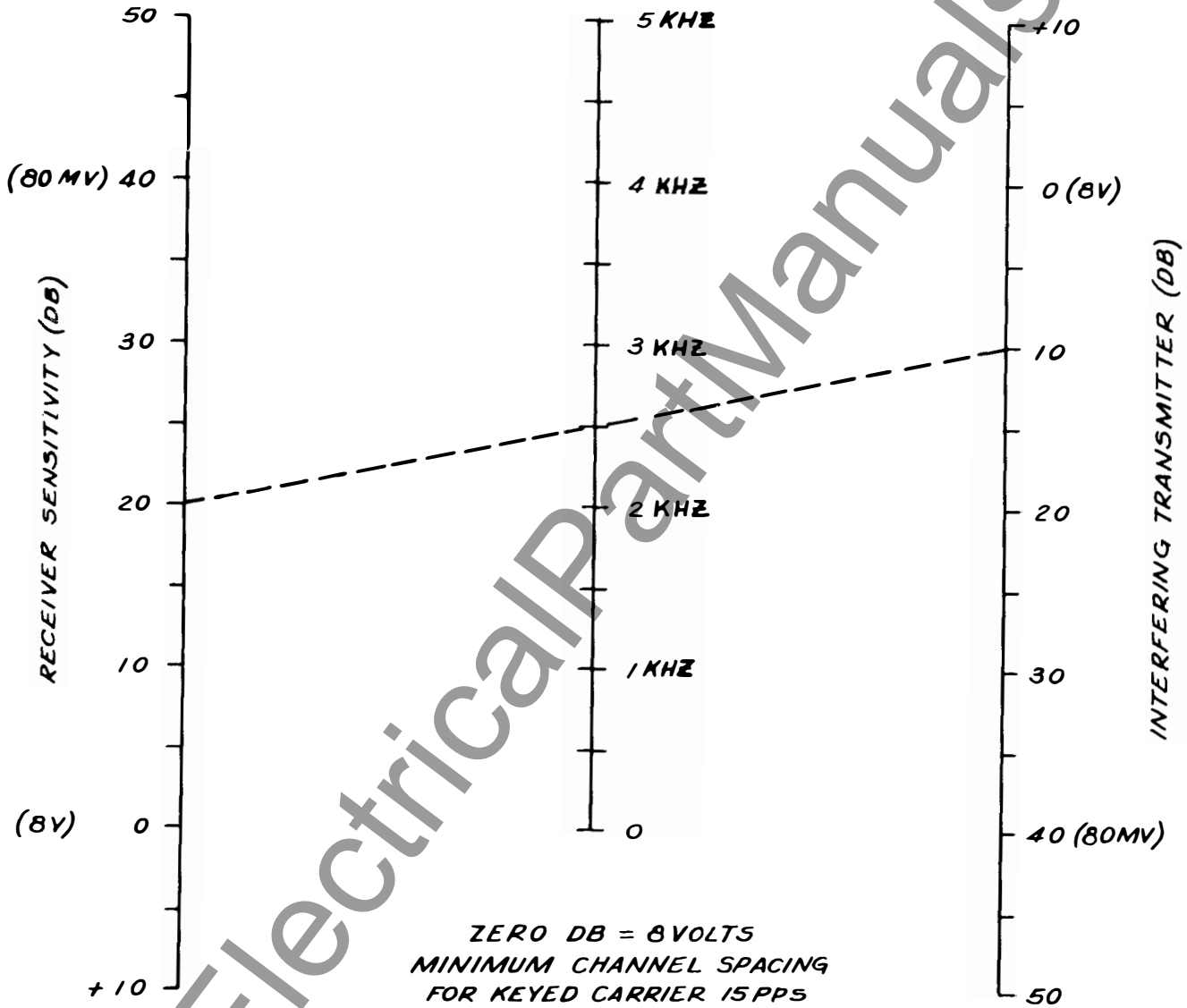
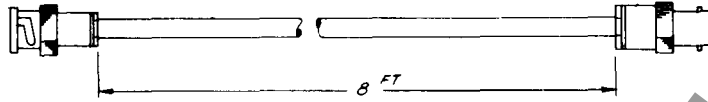
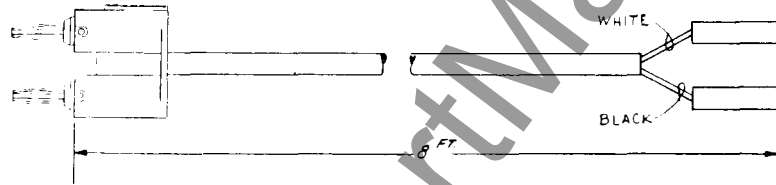

Fig. 14. Minimum Channel Spacing (Curve #377998)



Coaxial Lead... 756D346 G02



Output Lead... 756D346 G03

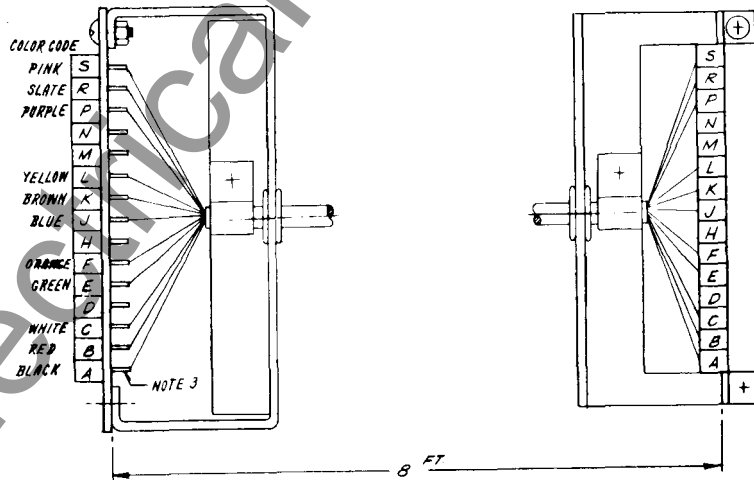

Main Harness... 756D346 G04

Fig. 15. Test Harness - (Complete Set)

www.ElectricalPartManuals.com

www.ElectricalPartManuals.com



WESTINGHOUSE ELECTRIC CORPORATION
RELAY-INSTRUMENT DIVISION

NEWARK, N. J.

Printed in U.S.A.

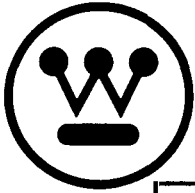

INSTALLATION • OPERATION • MAINTENANCE I N S T R U C T I O N S

TYPE KR CARRIER RELAYING TRANSMITTER-RECEIVER

Flexitest Case Mounted —with provision for rear-mounter Voice Adapter Accessories.	Style
KR Reserve Signal Detector	470D167 GO2
250 Volt Resistor Unit	330C191 H01
Test Harness (Complete Set)	756D346 G01
Coaxial Lead	756D346 G02
Output Lead	756D346 G03
Main Harness	756D346 G04

TABLE OF CONTENTS

Introduction	Page 2
Specifications	Page 2
Description	
General	Page 3
Mechanical	Page 3
Electrical	
Transmitter	Page 4
Receiver	Page 4
Transmitter Control Circuits	Page 5
Reserve Signal Detector	Page 5
Communications	Page 5
Relaying Control Circuits	Page 5
Installation	
General	Page 6
Connections	
External	Page 6
Internal	Page 7

Adjustments

Transmitter	Page 7
Receiver	Page 7
Reserve Signal Detector	Page 8
250-Volt Resistor Unit	Page 8
Frequency Change	Page 8

Maintenance	Page 9
Application	Page 13
Electrical Parts List	Page 14

LIST OF TABLES

Table

1 D-C Pin Jack Measurements with Reference to B-	Page 10
2 Transistor DC Measurements with Reference to B-	Page 11
3 D-C Bleeder Measurements with Reference to B-	Page 12
4 Typical RF Signal Measurements for Receiver	Page 12
5 Typical RF Signal Measurements for Transmitter	Page 13

LIST OF ILLUSTRATIONS

Figure		References
1	Outline – Flexitest Case	540D753
2	Internal Schematic	540D780
3	Relaying Control Circuits (HZ/HZM)	1-329C704
4	Relaying Control Circuits (K-Dar)	3-329C704
5	Relaying Control Circuits (GCX/GCY).....	2-329C704
6	Component Location.....	540D781
7	Supervisory Control Receiver Connection.....	223B498
8	Connections, 48-250 volts and Supervisory Control.....	407C971
9	Transmitter Output Filter Connections	149A420
10	Transmitter Output Filter Selectivity.....	C377996
11	Reserve Signal Detector – Outline and Schematic	329C703
*	12 Receiver Selectivity	C377993
13	Receiver Filter Limits	C377995
14	Minimum, Channel Spacing	C377998
15	Test Harness	756D346

CAUTION The voltages encountered in this equipment are dangerous to life. To be safe, disconnect the power source and close the grounding switch when servicing the equipment.

INTRODUCTION

The Type KR Relaying Transmitter-Receiver is designed for Distance Relaying, Telemetry, Supervisory Control and Sleet Detection. Facilities are provided for a plug-in type voice adapter. The basic design is for operation from 125-volt station batteries. However, the apparatus may also be operated from 48-volt or 250-volt station batteries by means of various internal connections. These various connections as well as most of the adjustments are made at the factory, although they can be changed in the field.

Although designed primarily for operation with Westinghouse protective relays, this apparatus may also be coordinated with other types of directional-distance relays and with most other contact keyed devices.

SPECIFICATIONS

Frequency Range.....	30-kHz to 200kHz
Channel Attenuation Rating	40-db
Transmitter Power Output.....	1.0 watt with a 125 V.D.C. * supply. 0.5 watt with a 48-volt d-c supply.
Transmitter Harmonic Output	At least 46-db below funda- mental.
Transmitter Output Impedance.....	Matches one 60-ohm coax. cable. (Suitable for 50-70 ohm cable.)
Transmitter Output Filter Selectivity	See Fig. 10
Transmitter and Receiver Oscillator and Frequency Stability	From - 20° C to + 55° C with si- * multaneous voltage variations from 105 to 140 VDC, the fre- quency remains with 0.01%.

Permissible Battery Voltage Ripple	7-1/2%
Ambient Temperature Range	- 20° C to + 55° C.
* Receiver Maximum Sensitivity025 volts for 10 ma. output.
Receiver Selectivity	See Fig. 12
Receiver Signal-to-Noise Ratio Requirements	12-db
Minimum Channel Spacing	See Fig. 14
Power Input	115-ma at 48 VDC, 200-ma at 125 VDC, 1.28 amperes at 250 VDC.
Carrier On-Off Keying	Requires one pair of contacts capable of keying 8-ma DC at an open circuit voltage of 125 VDC.
Weight (With Flexitest Case)	Approximately 16-lbs.

CAUTION Refer application to Westinghouse when other transmitters are to be connected to the same coax cable as certain conditions may result in damage to the output transistors.

such as potentiometers, jack, test points, crystals, transistors, etc. External connections and the Schematic Diagram are shown by Fig. 2. The numbered terminals shown as squares apply to the external terminals.

DESCRIPTION

Mechanical

This apparatus is supplied in a Flexitest case and may be either flush or projection mounted in order to match other switchboard equipment. The outline dimensions and also the drilling plan for flush and projection mounting are shown by Fig. 1. The majority of the parts are mounted on a printed circuit board. This board may be readily removed as follows:

1. Remove the two output plugs from the red and black jacks.
2. Disconnect the receiver input coaxial cable connector.
3. Loosen the two screws at the top of the board.
4. Loosen the two screws at the bottom of the board and pull them out as far as they will extend.
5. Pull board down to disengage the terminals and lift out.

The transmitter output filter may be removed by removing four mounting screws from the bottom of the case and disconnecting the coaxial cable.

Fig. 6. shows the location of major components

Provisions are made for plugging the Voice Adapter Unit in the rear of the relaying equipment. Octal socket marked X-4 on the rear of the set accommodates the adapter plug. A buckle type strap on each side of the adapter holds the unit in place after it has been plugged in. The normal projection for a rear mounted Voice Adapter is 3-inches beyond that of the relaying equipment. When the KR Relaying Unit is supplied with the adapter, a patch cord is available on separate order. This patch cord plugs into the telephone jacks on the adapter and provides an extension to a conveniently located terminal board.

The panel cutout information necessary for mounting the Reserve Signal Detector is shown by Fig. 11. This unit consists of a potentiometer and pushbutton switch mounted on a small panel, itself suitable for switchboard mounting.

For 250-volt operation, separate auxiliary resistors are required, as shown in Fig. 8.

Electrical

Transmitter

The transmitter is made of four main stages in -

TYPE KR CARRIER SET

cluding an oscillator, driver, power amplifier, and an output filter. In the oscillator, the crystal is operated as a resonant circuit between the collector of one transistor and the base of the other. The feedback is supplied through a capacitor from the collector of the second transistor to the base of the first transistor. The frequency is independent of voltage or temperature changes of the transistors. Thus the frequency stability is the stability of the crystal.

The input to the driver stage Q-10 is controlled by potentiometer, R-42 which also controls the transmitter power output. In HZM relaying CARRIER STOP provides about +40 volts for blocking. This is applied to Q-10 through T-6. Diode CR-5 prevents damage to the transistor when this positive voltage is applied to the collector. For CARRIER START (when in the blocked position) a small positive voltage is applied to the collector of Q-10 by means of bleeder resistors R-67 and R-68.

The power amplifier consists of two transistors Q-12 and Q-15, which are operated as class B amplifiers in push-pull. Resistors R-52 and R-55 are for stabilization.

The output transformer, T-7, matches coaxial cables of 50 to 70 ohms.

Resistor R-66 tends to keep the source impedance constant to permit proper tuning of the output filter.

The output filter consists of coils L-1 and L-2, capacitors C-19 through C-22. The filter is tunable, and is provided to attenuate harmonics and other spurious outputs. It should be noted that the filter contains no shunt elements, resulting in a reverse impedance free of "across the line" resonances.

Receiver

* The receiver is a superheterodyne in order to obtain constant selectivity regardless of the channel frequency. (See Fig. 12) The major stages include an input filter, attenuator, oscillator, mixer, IF filters, IF amplifiers, detector and a D-C power output stage.

The receiver sensitivity is adjusted by means of the continuously variable input control R-1 and by connecting or disconnecting resistors R-73 and R-74 in the IF stages.

The receiver oscillator (Q-2 and Q-3) is basic-

ally the same as the transmitter oscillator. The frequency is 20-kHz above the incoming signal frequency.

The receiver channel frequency is determined by the input filter and the oscillator crystal. The frequency may be changed readily since both the filter and the crystal are plug-in components.

Mixing is accomplished by feeding the incoming signal to the emitter and the receiver oscillator signal to the base of the mixer Q-1. Mixer oscillator requirements are met through adjustment of potentiometer R-4. Injection into two separate elements, base and emitter, provides a circuit capable of handling greater signal level variations than one in which injection is made into only a single element such as the base.

* This receiver uses an IF frequency of 20-kHz. The overall selectivity is determined primarily by the IF filter FL-2. Typical characteristics of this filter are shown in Fig. 13. The IF amplifier consists of transistors Q-4, Q-5 and Q-6.

The detector is a full wave bridge rectifier. This rectifier in conjunction with the IF amplifier Q-6, provides the necessary power to drive the D-C power output stage Q-7. The final output stage Q-7 will supply approximately 18 milliamperes to a standard 1700 ohms distance relay RRRH coil and its associated 500 ohm alarm coil. It may also be used to drive other relay coils such as is shown by Fig. 7, Supervisory Control Connections.

Transmitter Control Circuits

In the standby condition, although the oscillator is running, the transmitter driver has no emitter bias which results in no output.

Positive voltage applied to terminal 15 supplies this bias through a voltage dividing network, and transmitter output results. The actual configuration of the network is a function of supply voltage and application (Relaying, Telemetry, etc.) and is discussed in the Adjustments section.

Output may be stopped in several ways. The method used with K-DAR relays is to remove the positive voltage applied to terminal 15. In the case of distance relaying with Westinghouse HZ/HZM relays, application of a positive voltage to terminal

18 will stop the transmitter output. Output may also be stopped by removal of negative battery from terminal 18.

Reserve Signal Detector

The Reserve Signal Detector is shown by Fig. 11. Effectively R-1 is a remote transmitter output control. This control is obtained through varying the driver Stage (Q-10) emitter bias, and is effective over a 25-db range of transmitter output. The detector is switched into service by S-1. By adjusting R-1 for a given receiver relay current at the far end of the channel, a relative measure of the channel attenuation may be obtained. This is discussed further in the section on Adjustments.

Communications

The transmitter output is reduced approximately 6-db when the Type KR voice adapter attachment is used. Relaying takes preference, and full output is * obtained when full voltage is supplied to terminal 15.

Relaying Control Circuits

Figs. 3, 4 and 5 show simplified diagrams of the relaying control circuits.

1. K-DAR and GCY Relaying (Figs. 4 and 5)

The control of the carrier set is obtained through the CARRIER START and CARRIER STOP contacts. These contacts are shown in their normal standby condition.

The K-DAR or GCY relays operating from the voltage and current on the transmission line, detect and determine the direction of a line fault and thereby control the carrier transmitter and receiver.

The control of the carrier set is such as to start the transmission of carrier when fault power on the transmission line is flowing out of the line section being protected. Conversely, when fault power is flowing into this line section, the control is such as to block the transmitter and keep it from being turned on by secondary functions such as reserve signal detection and communication, should these functions be in use at the same time. Should carrier be received from the remote station, the hold coil and alarm coil will energize through transistor Q-7 in the receiver.

When carrier start operation occurs, the CARRIER

START contact opens applying a positive voltage (see Figs. 4 and 5) to terminal 15 of the carrier set. This puts a potential on the driver stage in the transmitter and also applies proper bias for the power amplifier.

When a carrier stop operation occurs, the CARRIER STOP contact closes, which removes B+ (terminal 15) from the driver and the power amplifier stages in the transmitter. CARRIER STOP, terminal 18, on the carrier set is permanently connected to terminal 14, for K-DAR and GCY relaying.

2. HZM Relaying (Fig. 3)

The control of the carrier set is effected by the CARRIER START and the CARRIER STOP contacts. These contacts are shown in their normal standby condition.

The HZ-HZM relays operating from the voltage and current on the transmission line, detect and determine the direction of a line fault and thereby control the carrier transmitter and receiver.

The control of the carrier set is such as to start the transmission of carrier when fault power on the transmission line is flowing out of the line section being protected. Conversely, when fault power is flowing into this line section, the control is such as to block the transmitter and keep it from being turned on by secondary functions such as reserve signal detection and communication, should these functions be in use at the same time. Should carrier now be received from the remote station, the hold coil and alarm coil will energize through transistor Q-7 in the receiver.

When carrier start operation occurs, the CARRIER START contact closes applying the full battery supply voltage to terminal 15 of the carrier set. This puts a potential on the driver stage in the transmitter and also applies proper bias for the power amplifier.

When a carrier stop operation occurs, the CARRIER STOP contact opens. This applies a positive voltage (see Fig. 3) to terminal 18 which blocks the driver stage and the power amplifier stage

It is possible under certain conditions that the signals from two transmitters, attempting to block a third receiver, would be of such amplitude, phase and frequency as to cause the RRH coil current to "pulsate". It would then be possible to have a false trip.

TYPE KR CARRIER SET

In the case of the KR set for relaying 3-terminal lines, the transmitter frequencies (to avoid this possibility of false trip) should be separated by 100 Hz. All receivers and one transmitter would be at the desired center frequency. One of the other transmitters would be 100 Hz above, the other 100 Hz below this center frequency.

INSTALLATION

General

Upon receipt of a unit, whether shipped separately or in an assembly, an immediate inspection should be made. Carefully check for damage or shortages.

For necessary clearances and mounting dimensions, see the following illustrations:

- Flexitest Case Mounting..... Fig. 1
Reserve Signal Detector Fig. 11

Connections

External

The external connections will vary slightly depending on the application, but in general will be as follows: (Refer to the Schematic Diagram, Fig. 2.)

- Terminals 11..... Ground
12..... Coaxial Cable

- 13 and 19 Supervisory Preference Contacts
14..... B- "CARRIER STOP" return
15..... Battery positive through carrier start contacts
16..... Battery positive for alarm cutoff (used with communication)
17..... B-
18..... Carrier Stop for HZM Relaying
19..... B+
20..... Relay Coil

CAUTION If the transmitter output load is removed while the transmitter is energized, the transistors in the power amplifier will be permanently damaged. A dummy load should be connected to the transmitter output if the coax is disconnected and the transmitter is to be energized.

When tuning line coupling equipment, short the coaxial cable to ground before changing taps on the Line Tuner or matching transformer.

Internal

Necessary internal connections are generally made at the factory, to customer order, before apparatus shipment. For reference purposes, these are outlined in the following tabulation. Check the proper bleeder resistors before applying voltage to the equipment.

OPERATION

- 48-Volt K-DAR, HZM, and GCY Relaying, Telemetering, and Supervisory
125-Volt K-DAR and GCY Relaying
125-Volt HZM Relaying, Telemetering, and Supervisory
250-Volt K-DAR and GCY Relaying
250-Volt HZM Relaying, Telemetering, and Supervisory

Various combinations of the inductors and capacitors of the transmitter output filter are required depending on the channel frequency. These are tabulated in Fig. 9.

Adjustments

This apparatus is generally tuned to and tested

BLEEDER RESISTORS IN THE CIRCUIT

at the specified channel frequency before shipment. Final adjustments must be made in the field and are described in the following paragraphs. Fig. 6 shows the locations of the various controls.

Transmitter

1. Disconnect the coaxial cable and replace with a 50, 60, or 70 ohm non-inductive resistor depending on the characteristic impedance of the cable used.

2. Fig. 9 shows typical output filter connections for various frequency ranges. In some cases it may be necessary to use either a higher or lower range to tune the filter to resonance.

3. Insert fuses F- 1 and F- 2 to apply power to the apparatus.

4. Connect an A-C Vacuum Tube Voltmeter (VTVM) across the non-inductive load.

R-47 and R-48

R-45, R-47 and R-48

R-41, R-45, R-47 and R-48

R-45, R-47 and R-48

R-39, R-40, R-41, R-45, R-47 and R-48

5. Unblock the transmitter by closing the CARRIER TEST SWITCH. An alternative is to jumper battery positive to terminal 15.

6. Beginning with the output control R-42 at the maximum counterclockwise position, advance it clockwise until a reading appears on the VTVM. Tune capacitor C-19 for a maximum voltmeter reading.

7. While increasing R-42, tune the output filter for maximum output until the output across the resistor is approximately 8 volts. (Approximately 5.5-volts when operating from 48-volt station battery.)

8. Open the test switch and reconnect the coaxial cable.

Receiver

1. The oscillator output control R-4 is pre-set at the factory. However, should any of the oscillator components be changed (including the transistors and the crystal) R-4 will require adjustment.

a. Connect an A-C VTVM to jacks J-3 and J-4.

b. Adjust R-4 for a 0.3 volt reading on the meter.

2. The unit is shipped to have a gain of approximately 250 millivolts (to produce 10 ma relay current) with input control R-1 in maximum clockwise position. About 10-db additional gain or 80 millivolt sensitivity can be obtained by clipping out resistor R-74, which is connected to the base of Q-4 and the B+ supply for the IF. A further 10-db gain or additional 25 millivolt sensitivity can be obtained by also clipping out resistor R-73, which is connected to the base of Q-5 and the B+ supply for the IF. Resistor R-71 and R72 have been selected at the factory to provide an overall gain of approximately 25 millivolts with R73 and R74 removed.

a. Sensitivity Adjustment for Noise

If the maximum on-frequency noise level is known or can be measured, the receiver can be adjusted for this level. Disconnect the coaxial cable and connect a 60-ohm non-inductive resistor and a VTVM across terminals 11 and 12. Energize the transmitter and output control R-42 for the same output as the maximum noise. Then adjust the receiver input control R-1 to obtain 1-ma output current. If it is impossible to obtain 1-ma output current with control R-1 in the maximum clockwise position, then clip out resistor R-74, which is connected to the base of Q-4. If the gain is still insufficient, clip out resistor R-73, which is connected to the base of Q-5. After completing the adjustment of R-1, restore the transmitter to full output.

b. Sensitivity Adjustment for Remote Signal

When the maximum on-frequency noise is unknown and cannot be conveniently measured, the receiver may be adjusted for the remote signal. First determine the channel attenuation using a Sierra voltmeter or some other convenient method. Disconnect the coaxial cable and connect a 60-ohm non-inductive resistor and a VTVM across terminals 11 and 12. Add 15-db to the channel attenuation. This compensates for average variations such as channel and voltage variations. For example, if the channel attenuation is 5-db, add this to the 15-db making a total of 20-db. Taking this from 8 volts output of the transmitter, the receiver should then be set for a sensitivity of 0.8 volts. To do this, adjust the transmitter output control R-42 for 0.8 volts and then adjust the receiver input control so as to obtain 10-ma output current. If it is impossible to obtain 10-ma output current with control R-1 in the maximum clockwise position, clip out resistor R-74, which is connected to the base of Q-4. If the gain is still insufficient, clip out resistor R-73, which is connected to the base of Q-5. After completing the adjustment of R-1, restore the transmitter to full output.

It must be kept in mind that the two preceding adjustment procedures are to be used as a guide and will cover the majority of cases; however, cases may arise where conditions change. For example, if the adjustment is made per part a., the noise may increase due to various reasons such as bad insulators, which would require adjusting the receiver to be less sensitive. In the adjustment of part b., the attenuation may increase due to sleet or line switching,

TYPE KR CARRIER SET

which would necessitate increasing the sensitivity of the receiver.

Reserve Signal Detector

Due to different types of operation and supply voltages, it is not practical to have a calibrated dial for this unit. However, calibration may be made at installation by recording transmitter output (either in db or volts) at various knob settings of the detector unit. Then, by adjusting the knob so as to obtain 10 milliamperes relay current at a remote receiver, any increase or decrease in line attenuation may be noted as the difference between the original setting, and the setting required to obtain the given 10 milliamperes.

250-Volt Resistor Unit

With the apparatus energized, adjust R-4 in the 250-volt resistor unit so as to obtain 125-volts at terminals 17 (B-) and 19 (B+) on the relaying set.

Frequency Change

If the frequency is changed in the field, it is necessary to change the input filter FL-1 to the desired channel frequency. This filter is of the plug-in type and may be removed by unsnapping the clamp and pulling the filter out. The transmitter oscillator crystal Y-2 must be changed to the desired channel frequency. The receiver oscillator crystal Y-1 must be changed to the desired channel frequency plus 20 kHz. Figure 9 shows the connections for the transmitter output filter. It is necessary to unsolder the existing connections and make the new connections per the chart. After completing the preceding, the tuning procedure as described under Adjustments for transmitter and receiver should then be followed.

Note also that capacitors C2 and C9 in the transmitter and receiver crystal oscillator circuits, respectively, may have to be changed. For frequencies below 110 kHz, these capacitors are 270 mmf. each. For frequencies of 110 kHz and above, the capacitors are 140 mmf. each.

CAUTION Turn power OFF before removing filters or transistors, as high transient currents may cause permanent damage to the transistors.

MAINTENANCE

Voltage values should be recorded after adjustment in order to establish reference values which will be useful when checking the apparatus. The readings

will remain fairly constant over an indefinite period unless a failure occurs. However, if transistors are changed, there may be considerable difference in these readings without the overall performance being affected.

Typical voltage and current values are given as follows. Voltages should be measured with VTVM. Readings may vary as much as $\pm 20\%$.

In the following paragraphs, the transmitter may be unblocked (transmitting) by closing the CARRIER START circuit in the case of HZM relaying, and by opening the CARRIER START circuit in the case of K-DAR and GCY relaying.

1. For D-C pin jack measurements with reference to B-, refer to Table 1.
2. For transistor D-C measurements with reference to B-, refer to Table 2.
3. For D-C bleeder measurements with reference to B-, refer to Table 3.
4. For typical RF signal measurements for receiver, refer to Table 4.
5. For typical RF signal measurements for transmitter, refer to Table 5.
6. Removal of Printed Circuit Board from Flexitest Case.

To remove the printed circuit board, unplug J-15 and J-16 located near the output filter. Loosen the two screws inside the case near the top. Loosen the slotted thumb screws at the lower end of the board and pull these screws out as far as they will extend. Also remove the receiver coaxial cable plug.

Pull board down so as to disengage the terminals, and lift out.

7. Removal of the Output Filter

After the printed board has been removed, remove the screws on the outside of the case at the bottom. Lift out filter and disconnect the coaxial cable.

8. Receiver Filters

- * Fig. 13 shows typical receiver selectivity curves both RF and IF. If the filters are checked in a test

setup, it is necessary to use an accurate signal generator or preferably a signal generator and a frequency counter.

9. Minimum Test Equipment for Installation

- a. Milliammeter 0-25 ma DC.
- b. 60-ohm 5-watt non-inductive resistor.
- c. A-C Vacuum Tube Voltmeter (VTVM). Voltage range 0.003 to 30 volts, frequency range 60 Hz to 230-kHz, input impedance 7.5 megohms.
- d. D-C Vacuum Tube Voltmeter (VTVM)

Voltage Range: 0.15 to 300 volts
Input Impedance: 7.5 megohms

10. Desirable Test Equipment for Apparatus Maintenance

- a. All items listed in Sections 8 and 9.
 - b. Signal Generator
- Output Voltage: up to 8 volts
Frequency Range: 20-kHz. to 230-kHz.
- c. Oscilloscope
 - d. Ohmmeter
 - e. Capacitor checker
 - * f. Test harness (See Fig. 15)

APPLICATION

* 1. Receiver Selectivity (Fig. 12)

This shows a typical curve of the overall selectivity of the receiver under steady state conditions.

2. Transmitter Output Selectivity (Fig. 10)

Typical curves are shown so that approximate bandwidths for keying purposes can be determined for any carrier frequency between 30-kHz and 200-kHz.

* 3. Minimum Channel Spacing (Fig. 14)

This is a graph from which minimum channel spacing can be obtained provided the signal strength of the interfering transmitter and the sensitivity setting of the receiver are known. These can be obtained from calculations or by measurements.

For example, if the interfering transmitter voltage is measured (at the receiver) and found to be 2.5 volts, this would be 10-db down from 8 volts. This point can be located on the right hand column of the graph. Then, if the receiver sensitivity were set to operate on 0.8 volts or 20-db, this point would be located on the left hand column. A line could then be drawn through the two points as shown by the dotted line. The intersection of this line with the center line indicates the minimum channel spacing. In this case if the interfering signal is being keyed on-off, at 15 pps, the minimum spacing would be 2.5-kHz.

* 4. Supervisory Control Connections (Fig. 7)

When supervisory control is used with relaying, the supervisory control relay coil is connected in series with the RRH coil in place of the alarm relay. When supervisory control is used alone, a 1200-ohm resistor R3 is connected in series with the control relay coil by removing the jumper across R3, as shown in Fig. 7. In order to maintain proper mark space ratio, the relay bias current is adjusted for 9 milliamperes as indicated.

The receiver RF filter and the IF filter limits are shown on Fig. 15. Both filters are of the plug-in type and the test circuits with pin connections are shown at the top of each curve. The IF filter is divided into two separate sections. The selectivity shown is for each section, and the pin connections for each section are also shown in the test circuit sketch.

TABLE 1

D-C PIN JACK MEASUREMENTS WITH REFERENCE TO B-

Description	Jack	CONDITION A Tx-Blocked †† Rx-No Signal		CONDITION B Tx-Blocked Rx-With Signal		CONDITION C Tx-Unblocked Rx-No Signal	
		129 VDC	51 VDC	129 VDC	51 VDC	129 VDC	51 VDC
RF Input	J-2	0	0	0.3 V	0.3 V		
DC Q-1 Base	J-3	20 V	20 V	20 V	20 V		
DC R _x B+	J-4	20 V	20 V	20 V	20 V		
DC R _x Osc	J-5	7 V	7 V	7 V	7 V		
DC Q-5 Base	J-6	20 V	20 V	20 V	20 V		
B-	J-7						
DC-P1-E	J-8	110 V	32 V	110 V	32 V	110 V	32 V
DC-Q-7 Base	J-9	69 V	0 V	78 V	2.3 V	66 V	0.3 V
DC Q-7 Emit	J-10	70 V	1.0 V	78 V	1.4 V	66 V	1.0 V
DC T _x Osc	J-11	7 V	7 V	7 V	7 V	7 V	7 V
B+	J-12	129 V	51 V	129 V	51 V	129 V	51 V
DC Q-10 Base	J-13					18 V	18 V
DC Q-10 Emit	J-14					18 V	18 V
RF ma out	J-15					130 ma	130 ma
DC ma RRH and ALARM				18 ma	18 ma		

†† Tx = transmitter, Rx = receiver

TABLE 2

TYPICAL TRANSISTOR DC MEASUREMENTS WITH REFERENCE TO B-

Transistor	Condition A Tx-Blocked Rx-No Signal (Volts)			Condition B Tx-Blocked Rx-With Signal (Volts)			Condition C Tx-Unblocked Rx-No Signal (Volts)		
	E†	B†	C†	E†	B†	C†	E†	B†	C†
Q-1	20.0	20.0	0.38	20.0	20.0	0.4			
Q-2	7	7.2	1.8	7	7.2	1.8			
Q-3	6.2	8.0	2	6.2	8	2.0			
Q-4	20.0	20.0	2.6	20.0	20.0	2.8			
Q-5	20.0	20.0	2.6	20.0	20.0	2.8			
Q-6									
129 VDC	110	110	129	115	114	129			
51 VDC	32	32	51	32	32	51			
Q-7									
129 VDC	70	68	129	78	80	86			
51 VDC	1.0	0	51	1.4	2.2	7.0			
Q-8	6.2	8	2	6.2	8	2	6.2	8	2
Q-9	7	7.2	1.8	7	7.2	1.8	7	7.2	1.8
Q-10††							18	18	0.4
Q-12††							0.27	0.20	50
Q-15††							0.27	0.20	50

† E-Emitter; B-Base; C-Collector.

†† With respect to term F on printed board.

TABLE 3

D-C BLEEDER MEASUREMENTS WITH REFERENCE TO B-

Measurement	129 VDC			51 VDC		
	A†	B†	C†	A†	B†	C†
Junction R-61 and R-62 (J-8)	110V	110V	110V	32V	32V	32V
Junction R-61 and R-27 (J-10)	70V	78V	66V	1.0V	1.4V	1.0V
Junction R-27 and R-60 (P1-P)	69V	77V	65V	0	0	0
Junction CR-8 and R-64 (P1-K)	58V	58V	58V	51V	51V	51V
Junction R-48 and R-47 (J-14)	—	—	18V	—	—	18V
Junction R-45 and R-47 (TP-9)	—	—	45V	—	—	51V
Junction R-45 and R-41 (TP-8)	—	—	98V	—	—	51V

† Conditions: A — Tx-Blocked, Rx-No Signal; B — Tx-Blocked, Rx-With Signal; C — Tx-Unblocked, Rx-No Signal.

TABLE 4
TYPICAL RF SIGNAL MEASUREMENTS FOR RECEIVER
(Made with 0.1 Volt at Terminal 5 of FL1)

Check Point	25 MV Sensitivity (Volts)	80 MV Sensitivity (Volts)	250 MV Sensitivity (Volts)
With Receiver Crystal Out			
FL1-5 to Gnd.	0.1	0.1	0.1
T1-1 to Gnd.	0.1	0.1	0.1
Q1-E to Gnd.	0.05	0.05	0.05
Q1-C to Gnd.	0.07	0.07	0.07
T3-1 to Gnd.	0.07	0.07	0.07
Q4-C to Gnd.	0.07	0.07	0.07
With Receiver Crystal In			
Q4-C to Gnd.	0.5	0.5	0.25
J6 to Gnd.	0.15	0.1	0.08
Q5-C to Gnd.	7.0	1.7	0.8
Q6-B to Gnd.	2.0	0.5	0.4
Q6-C to Gnd.	13.0	10.0	8.0
T4-1 to Gnd.	13.0	10.0	8.0
T4-3 to T4-4	4.5	3.5	2.5
J9 to J10 (DC)	0.74	0.75	0.65

TABLE 5

TYPICAL RF SIGNAL MEASUREMENTS FOR TRANSMITTER

CHECK POINT	VOLTS
T5-1 to Gnd.	5.5
T5-3 to Gnd.	1.0
J13 to Gnd.	0.085
Q10-C to Gnd.	6.0
T6-2 to Gnd.	6.0
Q12-B to Gnd.	0.8
Q15-B to Gnd.	0.8
Q12-C to Gnd.	38.0
Q15-C to Gnd.	38.0
T7-5 to Gnd.	9.8
Output to Gnd.	8.0

ELECTRICAL PARTS LIST

CIRCUIT SYMBOL	FUNCTION	DESCRIPTION	MANUFACTURER'S DESIGNATION
<u>CAPACITORS</u>			
C-1	Rcvr. Bleeder	2.0 μf , $\pm 20\%$, 200 VDC, Paper	330C567 H11
†C-2	Rcvr. Osc. Feedback	140/270 μf , $\pm 20\%$, 500 VDC, Mica	330C566H43 * or 330C566H57
C-3	Rcvr. Osc. Bleeder Bypass	0.02 μf , MRC, 600 VDC, Disc	330C569 H47
C-5	Q-6 Emitter Bypass	1.0 μf , $\pm 20\%$, 200 VDC Paper	330C567 H09
C-6	Rcvr. Rectifier Bypass	Same as C-5	
C-7	B- to B+ Bypass	2 μf , $\pm 10\%$, 600 VDC, Paper	14C9400 H18
C-8	B- to GND	1.0 μf , $\pm 10\%$, 1000 VDC, Paper	14C9400 H17
†C-9	Xmtr. Osc. Feedback	Same as C-2	
C-10	Xmtr. Osc.	Same as C-3	
C-11	Key Filter	0.1 μf , $\pm 20\%$, 200 VDC, Paper	330C567 H02
C-12	Q-10 Emitter Bypass	0.25 μf , $\pm 20\%$, 200 VDC, Paper	330C567 H05
C-13	Q-10 Bleeder Bypass	Same as C-12	
C-14	PA Base Bypass	Same as C-12	

† Note: 140 μf for osc. freq. 110-kHz and above.
270 μf for osc. freq. below 110-kHz.

CIRCUIT SYMBOL	FUNCTION	DESCRIPTION	MANUFACTURER'S DESIGNATION
CAPACITORS (Concluded)			
C-18	PA Bleeder	0.5 μf , $\pm 20\%$, Paper	330C567 H06
C-19	Output Filter Tuning	500 μf , Variable, Air	328C092 H01
C-20	Output Filter	390 μf , $\pm 5\%$, 2500 VDC, Mica	330C561 H15
C-21	Output Filter	680 μf , $\pm 5\%$, 2500 VDC, Mica	330C561 H21
C-22	Output Filter	1200 μf , $\pm 5\%$, 2500 VDC, Mica	330C561 H27
C-24	FL-2 Decoupling	Same as C-12	
C-25	Q-7 Emitter	12 mfd, $\pm 20\%$, 200 VDC	187A177 H01
C-26	Q-7 Base Bypass	.01 mfd, $\pm 10\%$, 100 VDC	763A219 H15
D I O D E S			
CR-1	Bridge Rectifier	General Purpose, 1N63	584C433 H02
CR-2	Bridge Rectifier	Same as CR-1	
CR-3	Bridge Rectifier	Same as CR-1	
CR-4	Bridge Rectifier	Same as CR-1	
CR-5	Q-10 Collector	Same as CR-1	
CR-6	Q-7 Base Emitter	Type 1N457A	184A855 H07
CR-7	Voltage Regulator	Type 1N3686	185A212 H06
CR-8	Voltage Regulator	Type 1N1369	584C434 H05
CR-9	Q-7 Collector	Type 1N3811	185A089 H08
CR-10	Q-10 Emitter	Type 1N3028A	188A302 H14
CR-11	Voltage Regulator	Type 1N3024B	188A302 H12

ELECTRICAL PARTS LIST

CIRCUIT SYMBOL	FUNCTION	DESCRIPTION	MANUFACTURER'S DESIGNATION
<u>FUSE HOLDERS</u>			
FH-1	B-	For Type 3AGC Fuses	584C271 H02
FH-2	B+	Same as FH-1	
<u>FUSES</u>			
F-1	B-	3AGC 3/4 amp.	S#330C691 H12
F-2	B+	Same as F-1	
<u>FILTERS</u>			
FL-1	Rcvr. RF Bandpass	30 to 200 kHz Freq. to be specified by customer	
FL-2	Rcvr. IF Bandpass	20-kHz Fixed Freq.	
<u>CONNECTORS</u>			
J-1	Printed Circuit	Printed Circuit Female Plug	54-B-7125 H03
J-2	RF Input	UG-185-U	584C292 H07
J-3	Rcvr. Osc. Output	Terminal Studs	330C592 H01
J-4	Rcvr. Mixer-Amp Supply	Same as J-3	
J-5	Rcvr. Osc. Supply	Same as J-3	
J-6	Q-5 Base	Same as J-3	
J-7	B-	Same as J-3	
J-8	Q-6 Supply	Same as J-3	

ELECTRICAL PARTS LIST

CIRCUIT SYMBOL	FUNCTION	DESCRIPTION	MANUFACTURER'S DESIGNATION
		<u>CONNECTORS (Concluded)</u>	
J-9	Q-7 Base	Same as J-3	
J-10	Q-7 Emitter	Same as J-3	
J-11	Xmtr. Osc. Supply	Same as J-3	
J-12	B+	Same as J-3	
J-13	Xmtr. Osc. Output	Same as J-3	
J-14	Q-10 Supply	Same as J-3	
J-15	Output Filter	Banana Tip Red	328C093 H01
J-16	Output Filter GND	Banana Tip Black	328C093 H02
P-1	Printed Circuit	Printed Circuit Male Plug	54-B-7126 H03
		<u>INDUCTORS</u>	
L-1	Core and Coil Assembly	11 MH Total – 6 MH Tap (Part of FL-3)	329C450
L-2	Core and Coil Assembly	2.5 MH (Part of FL-3)	329C449
L-3	RF Choke	1.0 MH, 300 ma	R-300
L-4	RF Choke	Same as L-3	
		<u>TRANSISTORS</u>	
Q-1	Rcvr. Mixer	Type 2N525	184A638H13
Q-2	Rcvr. Gsc.	Type 2N414	184A638H14

ELECTRICAL PARTS LIST

CIRCUIT SYMBOL	FUNCTION	DESCRIPTION	MANUFACTURER'S DESIGNATION
<u>TRANSISTORS (Concluded)</u>			
Q-3	Rcvr. Osc.	Same as Q-2	
Q-4	Rcvr. IF	Same as Q-1	
Q-5	Rcvr. IF	Same as Q-1	
Q-6	Rcvr. IF	Type 2N498 or Type 2N657	184A638H15 184A638H15
Q-7	Rcvr. Output	Type 2N698	762A585H02
Q-8	Xmtr. Osc.	Same as Q-2	
Q-9	Xmtr. Osc.	Same as Q-2	
Q-10	Xmtr. Amp.	Same as Q-1	
Q-12	Xmtr. PA	Type 2N498 or Type 2N657	184A638H07 184A638H15
Q-15	Xmtr. PA	Same as Q-12	
<u>RESISTORS</u>			
R-1	Rec. Input	25 K, $\pm 20\%$, 1/4 W, Pot.	584C276 H23
R-2	Filter Matching	10 K, $\pm 10\%$, 1/2 W	330C595 H37
R-3	Filter Load	Same as R-2	
R-4	Rcvr. Osc.	1 K, $\pm 20\%$, 1/4 W, Pot.	584C276 H19
R-5	Rcvr. Voltage Divider	6.2 K, $\pm 5\%$, 1 W	330C666 H68
R-6	Q-2 Collector	1.2 K, $\pm 5\%$, 1/2 W	330C664 H51
R-8	Rcvr. Voltage Divider	15K $\pm 1\%$, 3W *	763A126H08 *
R-9	Rcvr. Voltage Divider	Same as R-8	

ELECTRICAL PARTS LIST

CIRCUIT SYMBOL	FUNCTION	DESCRIPTION	MANUFACTURER'S DESIGNATION
		<u>RESISTORS (Continued)</u>	
R-10	Q-2 Base	Same as R-2	
R-11	Q-2 Base	100 K, $\pm 5\%$, 1/2 W	330C665 H05
R-12	Q-3 Collector	Same as R-6	
R-13	Q-3 Emitter	390 Ohms, $\pm 5\%$, 1/2 W	330C664 H39
R-14	Q-3 Base	Same as R-2	
R-15	Q-3 Base	Same as R-11	
R-16	Rcvr. Osc. Bleeder	2.2 K, $\pm 10\%$, 1/2 W	330C595 H41
R-17	Rcvr. Osc. Bleeder	18 K, $\pm 10\%$, 2 W	330C597 H40
R-18	Rcvr. Osc.	9.1 K, $\pm 5\%$, 1/2 W	330C664 H72
R-19	Q-4 Bias	100 Ohms, $\pm 5\%$, 1/2 W	330C664 H25
R-20	Q-4 Bias	Same as R-2	
R-21	Q-5 Bias	150 Ohms, $\pm 5\%$, 1/2W	330C664 H29
R-22	Q-5 Bias	Same as R-2	
R-23	Q-6 Bias	330 Ohms, $\pm 5\%$, 1/2 W	330C664 H37
R-24	Q-6 Bias	Same as R-2	
R-25	Q-6 Emitter	Same as R-19	
R-26	Q-7 Base	Same as R-6	
R-27	Q-7 Bias	20 Ohms, $\pm 5\%$, 1/2 W	330C664 H08
R-28	Xmtr. Osc. Bleeder	Same as R-18	
R-29	Xmtr. Osc. Bleeder	Same as R-17	
R-30	Xmtr. Osc. Bleeder	Same as R-16	

ELECTRICAL PARTS LIST

CIRCUIT SYMBOL	FUNCTION	DESCRIPTION	MANUFACTURER'S DESIGNATION
		<u>RESISTORS (Continued)</u>	
R-31	Q-8 Base	Same as R-11	
R-32	Q-8 Base	Same as R-2	
R-33	Q-8 Emitter	Same as R-13	
R-34	Q-8 Collector	Same as R-6	
R-35	Q-9 Base	Same as R-11	
R-36	Q-9 Base	Same as R-2	
R-37	Q-9 Collector	Same as R-6	
R-38	Key Filter	Same as R-23	
R-39	Buffer Voltage Divider	36 K, $\pm 5\%$, 2 W	330C668 H86
R-40	Buffer Voltage Divider	Same as R-39	
R-41	Buffer Voltage Divider	Same as R-2	
R-42	Xmtr. Osc. Output	Same as R-4	
R-43	Q-10 Bias	Same as R-23	
R-44	Q-10 Bias	33 K, $\pm 5\%$, 1/2 W	330C664 H85
R-45	Buffer Voltage Divider	15 K, $\pm 10\%$, 1 W	330C596 H39
R-47	Buffer Voltage Divider	6.8 K, $\pm 5\%$, 1/2 W	330C664 H69
R-48	Buffer Voltage Divider	15 K, $\pm 5\%$, 1/2 W	330C664 H77
R-49	PA Bias	27 K, $\pm 5\%$, 2 W	330C668 H83

ELECTRICAL PARTS LIST

CIRCUIT SYMBOL	FUNCTION	DESCRIPTION	MANUFACTURER'S DESIGNATION
		<u>RESISTORS (Concluded)</u>	
R-50	Xmtr. PA	Same as R-19	
R-52	Q-12 Emitter	10 Ohms, $\pm 5\%$, 1/2 W	330C664 H01
R-55	Q-15 Emitter	Same as R-52	
R-59	Xmtr. Bleeder	47 Ohms, $\pm 10\%$, 1/2 W	330C595 H09
R-60	Recvr. Bleeder	1 K, $\pm 5\%$, 25 W	584C416 H57
R-61	Recvr. Bleeder	600 Ohms, $\pm 5\%$, 25 W	584C416 H47
R-62	Recvr. Bleeder	350 Ohms, $\pm 5\%$, 25 W	584C416 H52
R-64	Xmtr. Bleeder	1200 Ohms, $\pm 5\%$, 25 W	584C416 H64
R-66	T-7 Load	560 Ohms, $\pm 5\%$, 2 W	330C668 H43
R-67	Xmtr. Blocking	10 Ohms, $\pm 5\%$, 2 W	330C668 H01
R-68	Xmtr. Blocking	10 K, $\pm 10\%$, 10 W	330C577 H01
R-69	Q-10 Emitter	Same as R-19	
R-70	FL2 Decoupling	470 Ohms, $\pm 10\%$, 1/2 W	330C595 H21
R-71	Q-4 Emitter	Determined in test *	
R-72	Q-5 Emitter	Determined in test *	
R-73	Q-5 Base	220 Ohms, $\pm 10\%$, 1/2 W *	187A641H11
R-74	Q-4 Base	1K, $\pm 5\%$, 1/2 W *	184A763H27
R-75	Q-4 Collector	22 K, $\pm 10\%$, 1/2 W	330C595 H41
R-76	Q-5 Collector	Same as R-75	

ELECTRICAL PARTS LIST

CIRCUIT SYMBOL	FUNCTION	DESCRIPTION	MANUFACTURER'S DESIGNATION
<u>TRANSFORMERS</u>			
T-1	Rcvr. Input	Impedance Ratio 10 K; 10K	S#1962798, L-633005
T-2	Rcvr. Osc.	Impedance Ratio 10 K: 400 ohms	S#1962797, L-633003
T-3	Rcvr. Mixer	Impedance Ratio 25 K: 300 ohms	S#1962697, L-592171
T-4	IF Output	Impedance Ratio 4 K: 500 ohms	S#1962693, L-592289
T-5	Xmtr. Osc.	Same as T-2	
T-6	Xmtr. Buffer	Impedance Ratio 10 K: 400 ohms CT	S#1962698, L-592170
T-7	Xmtr. Output	Impedance Ratio 1930: 60	S#1962694, L-633000
<u>TEST POINTS</u>			
TP-1	R-5	Terminal studs	330C592 H02
TP-2	R-8	Same as TP-1	
TP-3	R-17	Same as TP-1	
TP-4	R-18	Same as TP-1	
TP-5	R-28	Same as TP-1	
TP-6	R-39 & R-40	Same as TP-1	
TP-7	R-41	Same as TP-1	
TP-8	R-45	Same as TP-1	
TP-9	R-47	Same as TP-1	

ELECTRICAL PARTS LIST

CIRCUIT SYMBOL	FUNCTION	DESCRIPTION	MANUFACTURER'S DESIGNATION
<u>SOCKETS</u>			
X-1	FL-1	Octal	330C689 H01
X-2	FL-2	Same as X-1	
X-4	Rear Mounted Voice Adaptor	Same as X-1	
XY-1	Rec. Y-1	Crystal	584C606 H01
XY-2	Xmtr. Y-2	Same as XY-1	
<u>CRYSTALS</u>			
Y-1	Rcvr. Osc.	Specify Channel Freq. Plus 20-kHz.	328C083
Y-2	Xmtr. Osc.	Specify Freq. Same as Channel Frequency	328C083
<u>RESERVE SIGNAL DETECTOR</u> (S#470D167G02)			
R-1	Resistor, Level Control	200 K, 2 W, Pot.	184A086H27
R-2	Resistor, Limiting	2000 ohms, 2" tube.	1267296
S-1	Test Switch	SPST Normally Open	327C854 H01

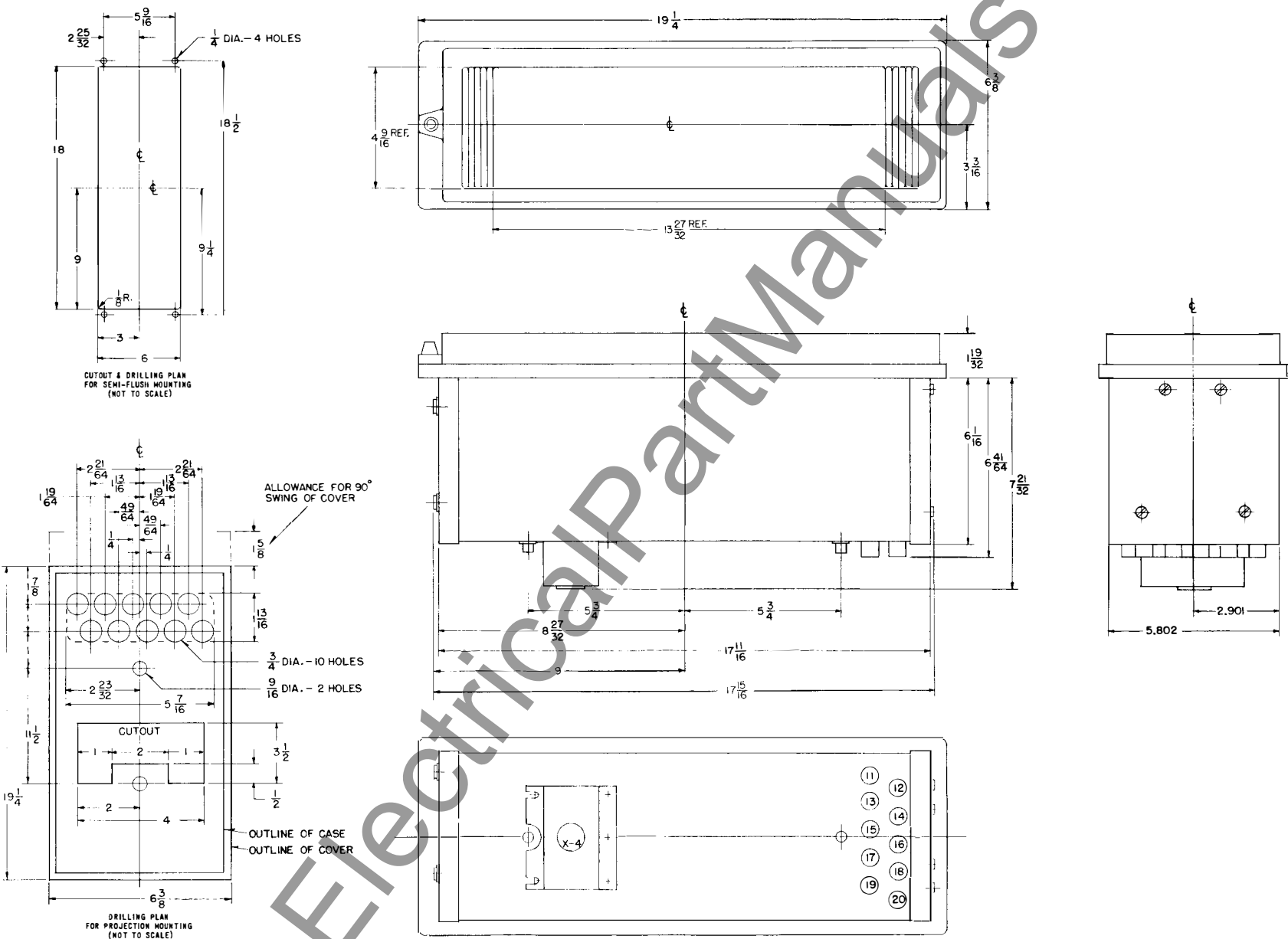
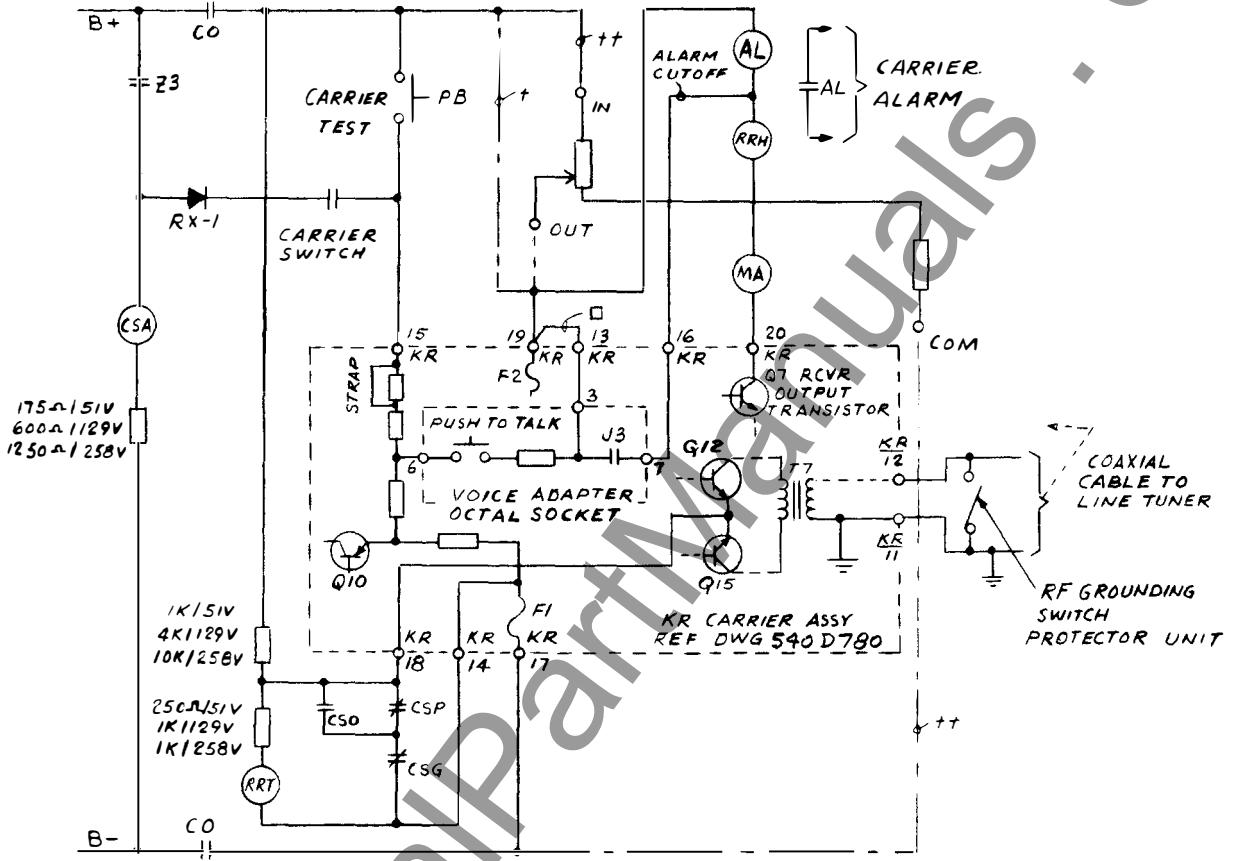

Fig. 1 Outline Drawing, (Flexitest Case) (540D753)

TYPE KR CARRIER SET



REQUIREMENTS FOR HZ/HM RELAYING			
SUPPLY VOLTAGE	CARRIER START	CARRIER STOP	STRAP
51VDC	+51V, 7MA	+28V	IN
129VDC	+129V, 8MA	+40V	IN
258VDC	+258V, 8MA	+40V	OUT

NOTES

- + FOR 51 & 129 VDC SUPPLY.
- ++ FOR 258 VDC SUPPLY USE 330C191H01 RESISTOR UNIT REF DWG 223B497
- FOR SUPERVISORY CONTROL PREFERENCE CONTACTS.

KR RELAYING TRANSMITTER / RECV EXTERNAL CONNECTIONS

TERMINAL - CONNECTION

- 11 GROUND
- 12 COAXIAL CABLE
- 13 SUPERVISORY PREFERENCE CONTACT
- 14 CARRIER STOP B- RETURN
- 15 CARRIER START (POSITIVE)
- 16 ALARM CUTOFF FOR COMMUNICATIONS
- 17 B MINUS
- 18 CARRIER STOP (HZ/HM)
- 19 B PLUS
- 20 RELAY COIL

Fig. 3- Relaying Control Circuits - HZ/HM (Dwg. 1-329C704)

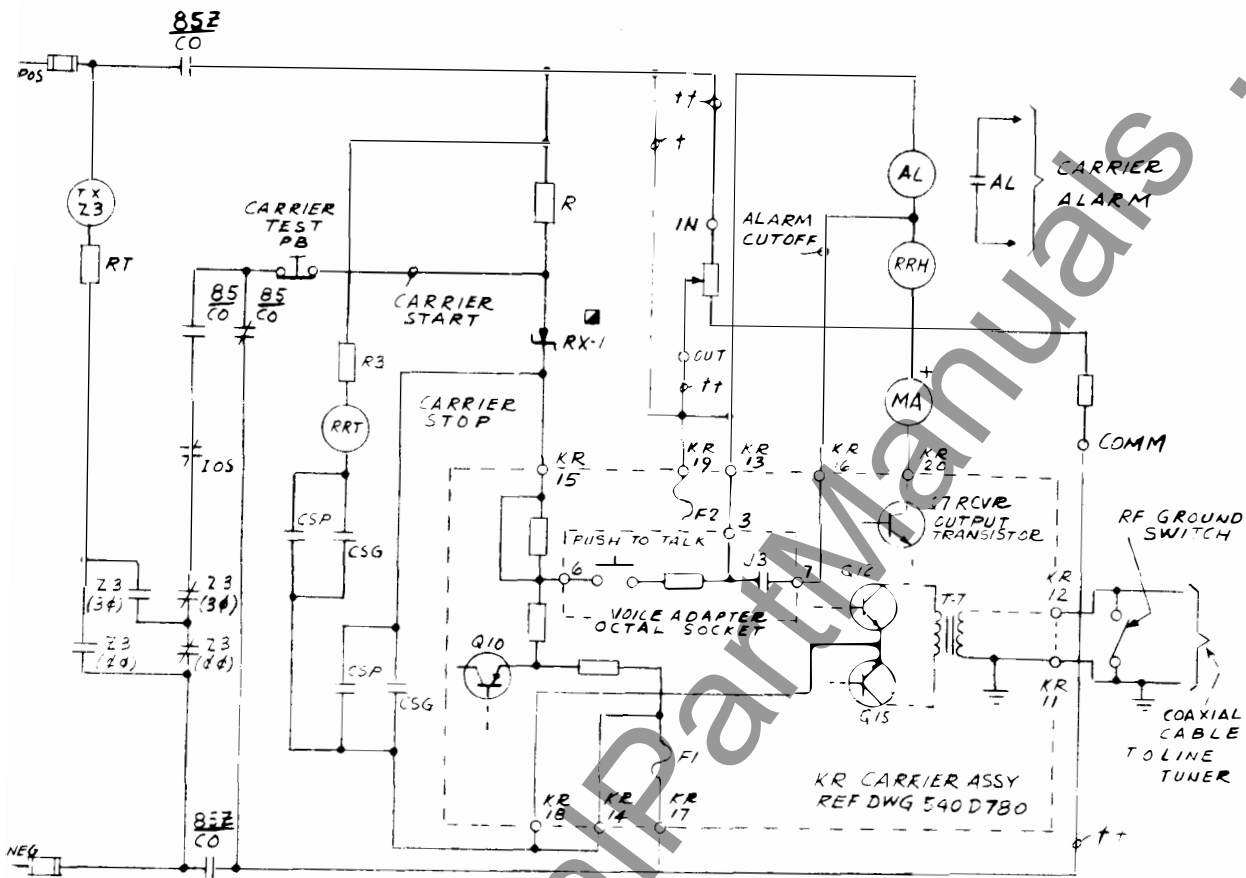

REQUIREMENTS FOR K-DAR RELAYING

SUPPLY VOLTAGE	CARRIER START	CARRIER STOP	R
51 VDC	+ 37V 7MA	0 VOLTS	2K
129 VDC	+100V 2MA	0 VOLTS	375K
258 VDC	+100V 2MA	0 VOLTS	19K

NOTES

KR RELAYING TRANSMITTER
 RECV EXTERNAL CONNECTIONS
 TERMINAL CONNECTION

- 11 SECOND
- 12 COAXIAL CABLE
- 13 SUPERVISORY PREFERENCE CONTACT
- 14 CARRIER STOP B-RETURN
- 15 CARRIER START (POSITIVE)
- 16 ALARM CUTOFF FOR COMMUNICATIONS
- 17 B MINUS
- 18 CARRIER STOP (HZ/HZM)
- 19 B PLUS
- 20 RELAY COIL

- TYPE IN3051 IN CARRIER AUX. RELAY
- + FOR 51 & 129 VDC SUPPLY
- ++ FOR 258VDC SUPPLY USE 330C191H01 RESISTOR UNIT REF DWG 223.B.497

Fig. 4-Relaying Control Circuits-K-Dar (Dwg. 3-329C704)

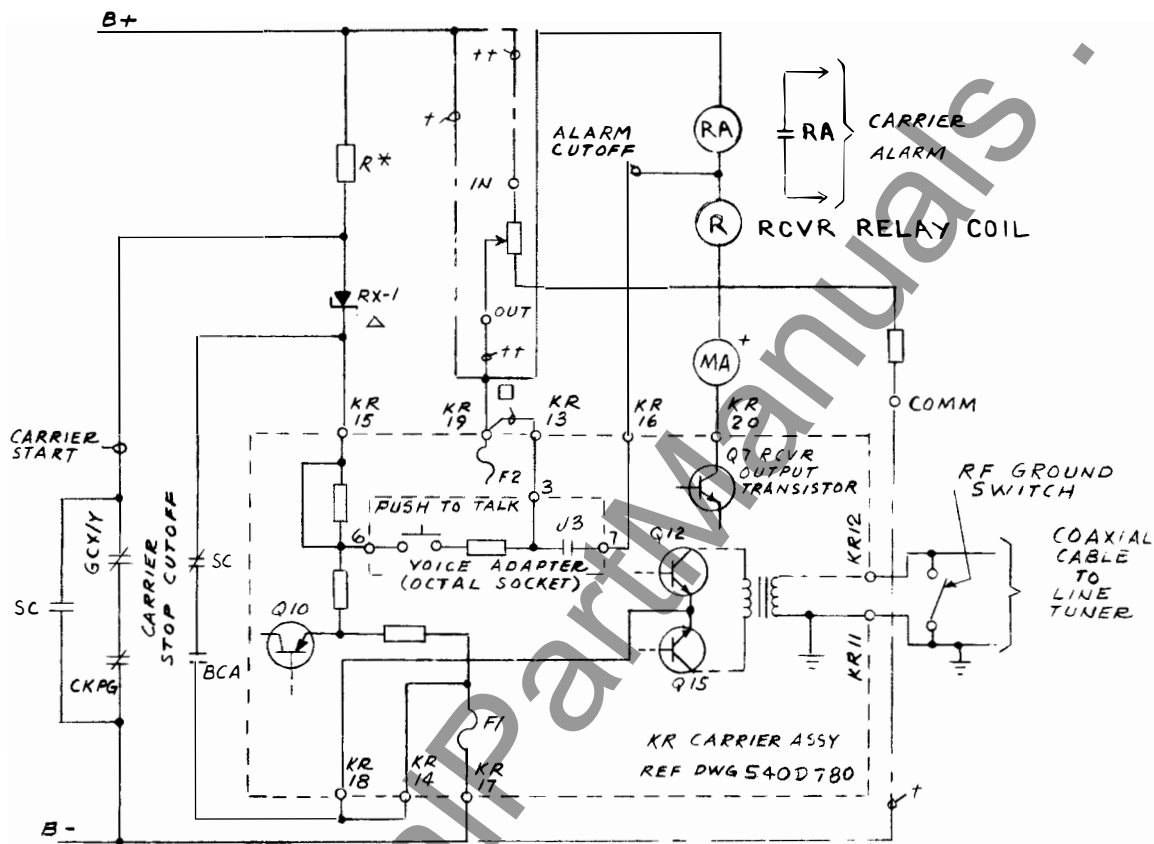

REQUIREMENTS FOR GCX/GCY RELAYING

SUPPLY VOLTAGE	CARRIER START	CARRIER STOP	R
51 VDC	+37V, 7MA	0 VOLTS	2K
129 VDC	+100V, 8MA	0 VOLTS	3.75K
258 VDC	+100V, 8MA	0 VOLTS	19.K

KR RELAYING TRANSMITTER /
RCVR, EXTERNAL CONNECTIONS
TERMINAL- CONNECTION

- 11. GROUND
- 12. COAXIAL CABLE
- 13. SUPERVISORY PREFERENCE CONTACT
- 14. CARRIER STOP B- RETURN
- 15. CARRIER START (POSITIVE)
- 16. ALARM CUTOFF FOR COMMUNICATIONS
- 17. B MINUS
- 18. CARRIER STOP (HZ/HZM)
- 19. B PLUS
- 20. RELAY COIL

NOTES

- * FOR "R" USE OHMITE VITREOUS ENAMELED DIVIDOHM ADJUSTABLE 4K OR 20K 25W RESISTOR, CONNECT & ADJUST FOR VALUES SHOWN
- △ TYPE IN3051
- † FOR 51 & 129 VDC SUPPLY
- †† FOR 258VDC SUPPLY USE 330C191H01 RESISTOR UNIT REF DWG 223B497
- FOR SUPERVISORY CONTROL PREFERENCE CONTACTS

Fig. 5. Relaying Control Circuits-GCX/GCY (Dwg. 2-329C704)

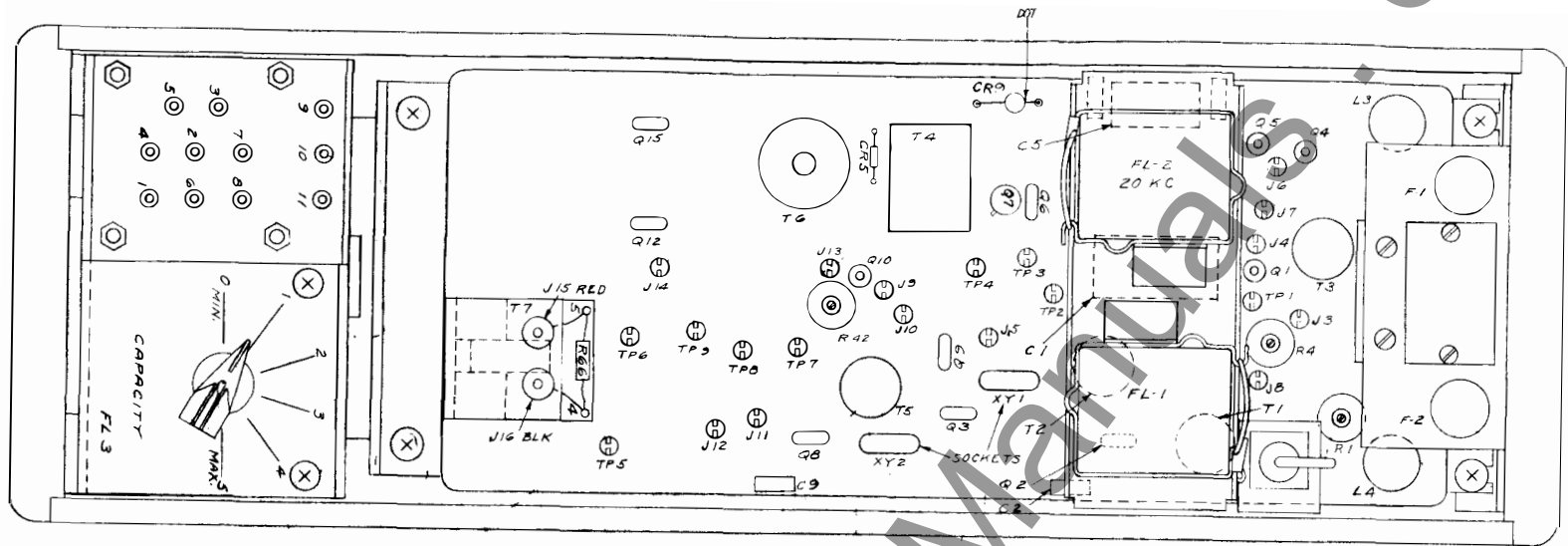
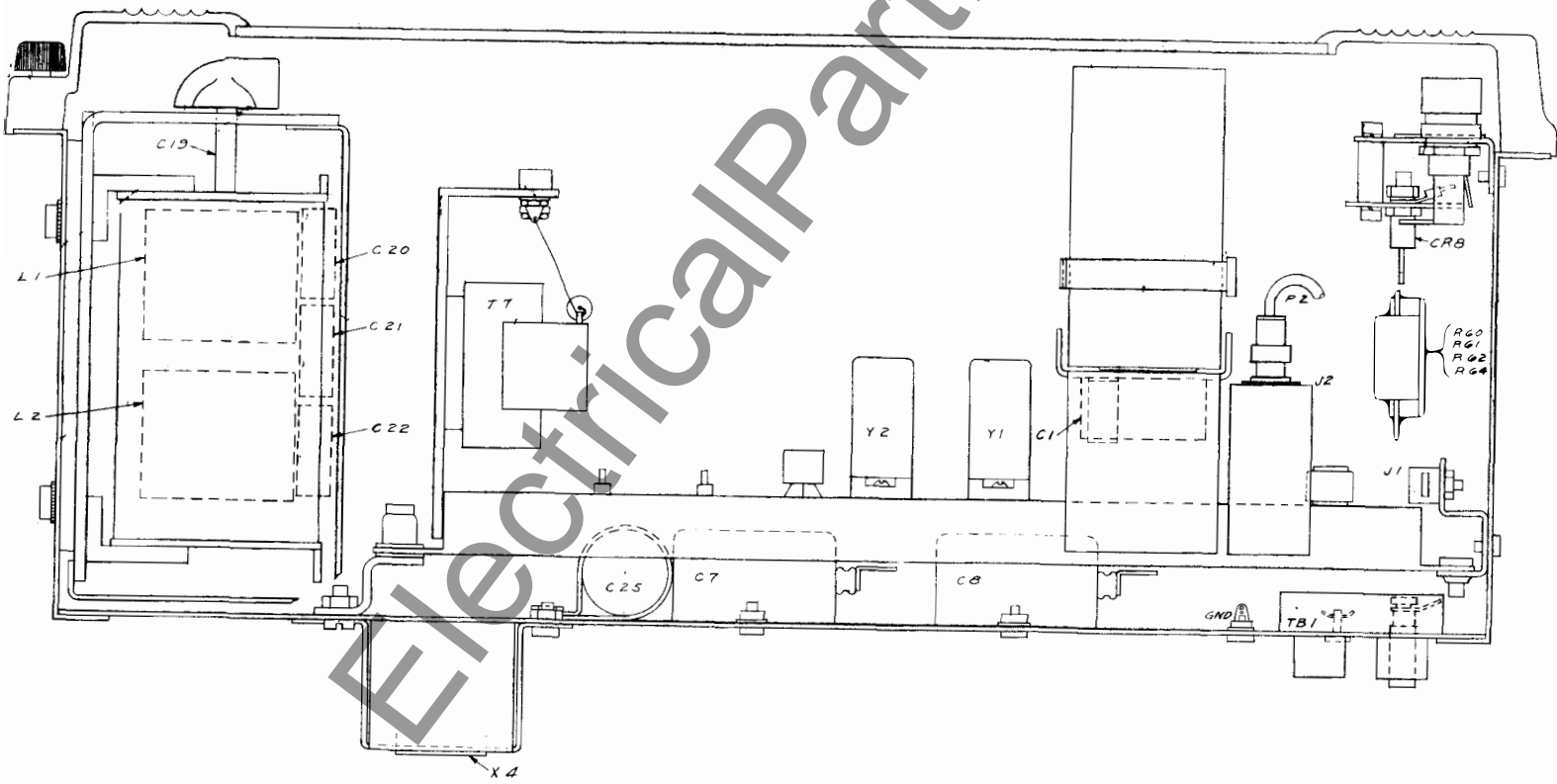
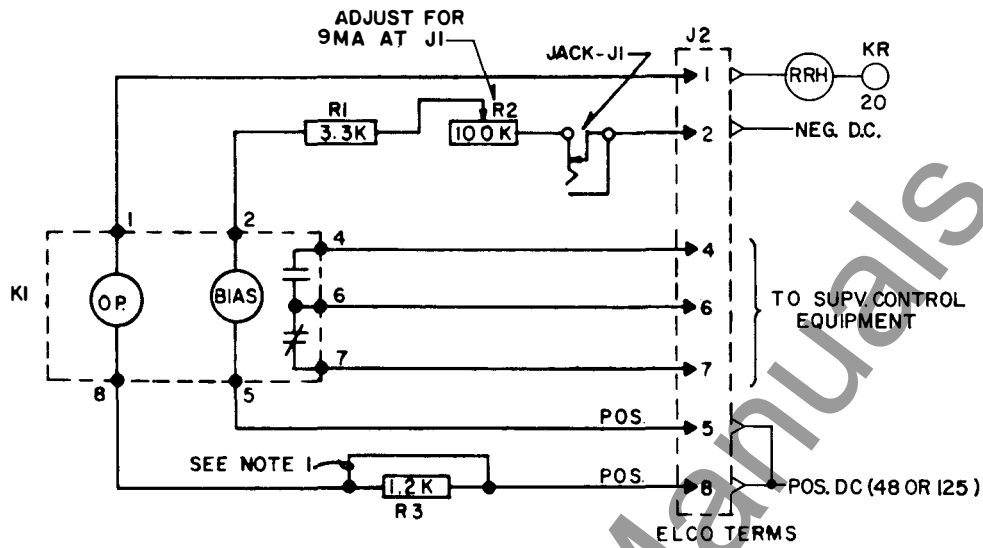
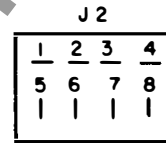

Fig. 6. Component Location (Dwg. 540D781)



NOTES:

1. REMOVE FOR KR CARRIER PLUS SUPV. CONTROL WITHOUT RELAYING.
2. POLARITY SHOWN CLOSES CONTACT BETWEEN TERMINALS 4 & 6.



AS VIEWED FROM REAR OF PANEL

629A552

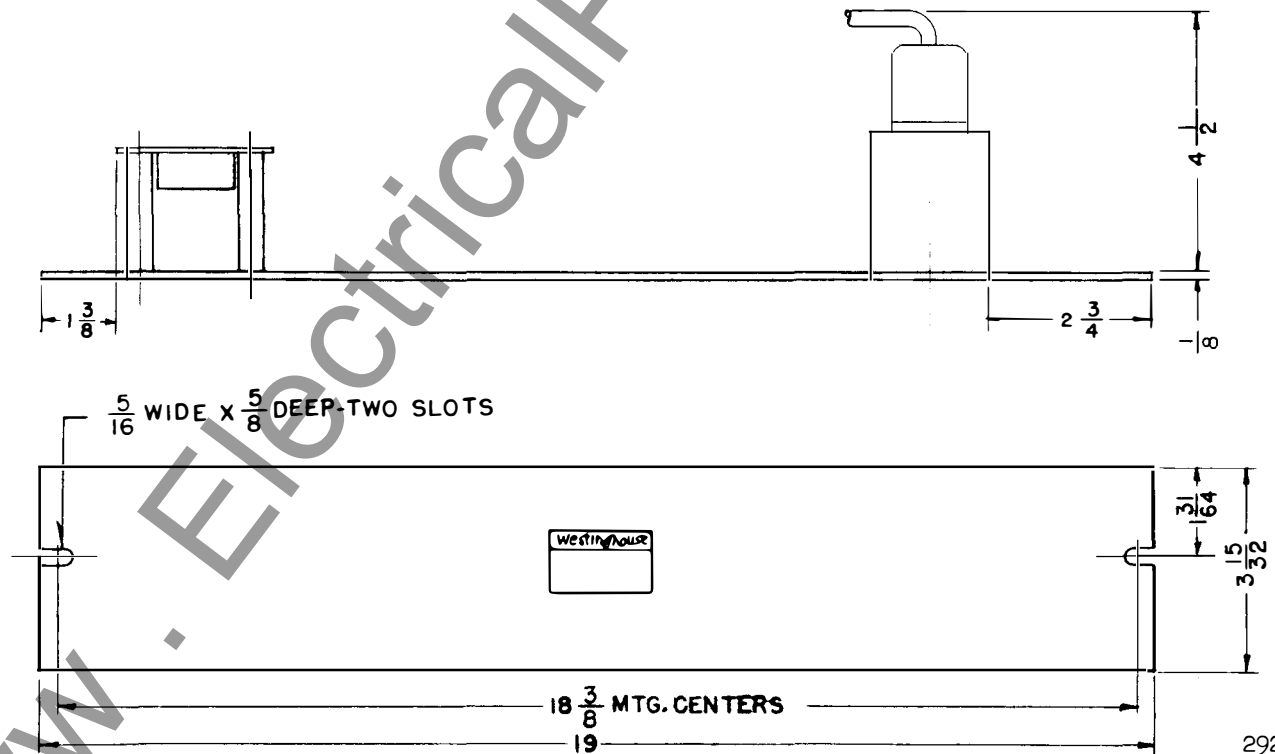

292B991

Fig. 7. Supervisory Control Auxiliary Relay Connections (Dwg. 629A552) and Outline (Dwg. 292B991).

**CONNECTIONS FOR 48-250 VOLT SERVICE AND
SUPERVISORY CONTROL APPLICATION**
(CHANGES FROM JUMPERS SHOWN ON INTERNAL SCHEMATIC, FIG.2)

250-VOLT OPERATION

FOR A 250 VOLT SUPPLY, RESISTOR UNIT 330C191H01 IS USED AS SHOWN ON APPLICATION DRAWING 329C704

FOR HZ/HZM OPERATION, THE JUMPER HAS BEEN REMOVED FROM TP-6 TO TP-7. (NOT REMOVED FOR K-DAR RELAYING).

RESISTOR UNIT SCHEMATIC:

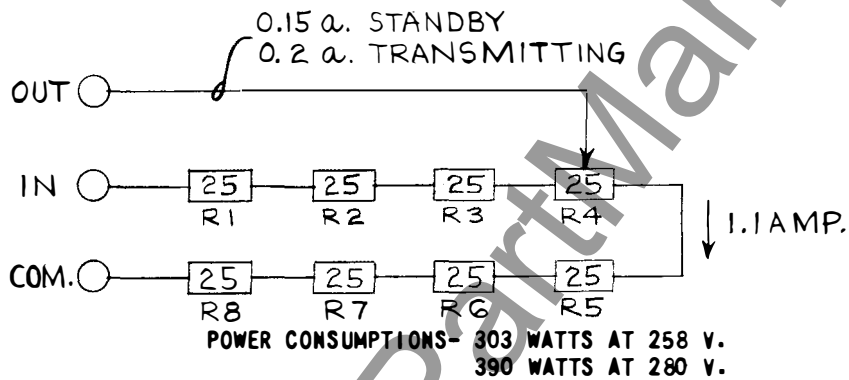

NOTE: KR SUPPLY VOLTAGE WILL BE APPROXIMATELY 144 VOLTS UNDER STANDBY CONDITION WHEN BATTERY VOLTAGE IS 280 VOLTS.

125-VOLT HZ/HZM OPERATION

JUMPER TP-7 AND TP-8 IS REMOVED.

48 VOLT OPERATION

ON PRINTED CIRCUIT BOARD ADDITIONAL JUMPERS ARE CONNECTED AS FOLLOWS:

- BETWEEN TP8 AND TP9
- BETWEEN TP5 AND J12
- BETWEEN TP1 AND TP2
- BETWEEN TP3 AND TP4

IN THE FT CASE, JUMPERS ARE CONNECTED ACROSS R60 AND R64, AND THE CONNECTION BETWEEN R64 AND DIODE CR8 IS REMOVED.

IN ADDITION, FOR 48-VOLT SUPERVISORY CONTROL, R59 IS CONNECTED INTO THE CIRCUIT.

Fig. 8. Connections, 48-250 Volts and Supervisory Control (Dwg. 407C971)

TRANSMITTER OUTPUT FILTER FL-3 CONNECTIONS

LINE	FREQUENCY RANGE	COIL	COIL CONNECTIONS	PARALLEL CAPACITOR CONNECTIONS Δ
1	27.7 KHZ-30.0 KHZ	L-1	(1-5) (3-6)	6-8-9-10-11
2	29.8 KHZ-33.1 KHZ	L-1	(1-5) (3-6)	6-8-10-11
3	31.8 KHZ-36.0 KHZ	L-1	(1-5) (3-6)	6-8-9-11
4	35.4 KHZ-39.0 KHZ	L-1	(1-5) (3-6)	6-8-11
5	38.0 KHZ-41.0 KHZ	L-1	(1-2) (3-6)	6-8-9-10-11
6	40.3 KHZ-45.0 KHZ	L-1	(1-2) (3-6)	6-8-10-11
7	43.0 KHZ-49.0 KHZ	L-1	(1-2) (3-6)	6-8-9-11
8	47.7 KHZ-56.0 KHZ	L-1	(1-2) (3-6)	6-8-11
9	49.5 KHZ-58.5 KHZ	L-1	(1-2) (3-6)	6-8-9-10
10	57.0 KHZ-72.3 KHZ	L-1	(1-2) (3-6)	6-8-10
11	67.0 KHZ-76.0 KHZ	L-2	(1-4) (6-7)	6-8-9-11
12	75.0 KHZ-88.0 KHZ	L-2	(1-4) (6-7)	6-8-11
13	77.5 KHZ-93.0 KHZ	L-2	(1-4) (6-7)	6-8-9-10
14	89.3 KHZ-114.5 KHZ	L-2	(1-4) (6-7)	6-8-10
15	102.7 KHZ-147.0 KHZ	L-2	(1-4) (6-7)	6-8-9
16	136.6 KHZ-210.0 KHZ	L-2	(1-4) (6-7)	6-8

Δ =CONNECTION FROM 6 TO 8 IS MADE BENEATH TERMINAL PLATE ON ALL SETS AT THE FACTORY.

Fig. 9. Connections - Output Filter (Dwg. 149A420)

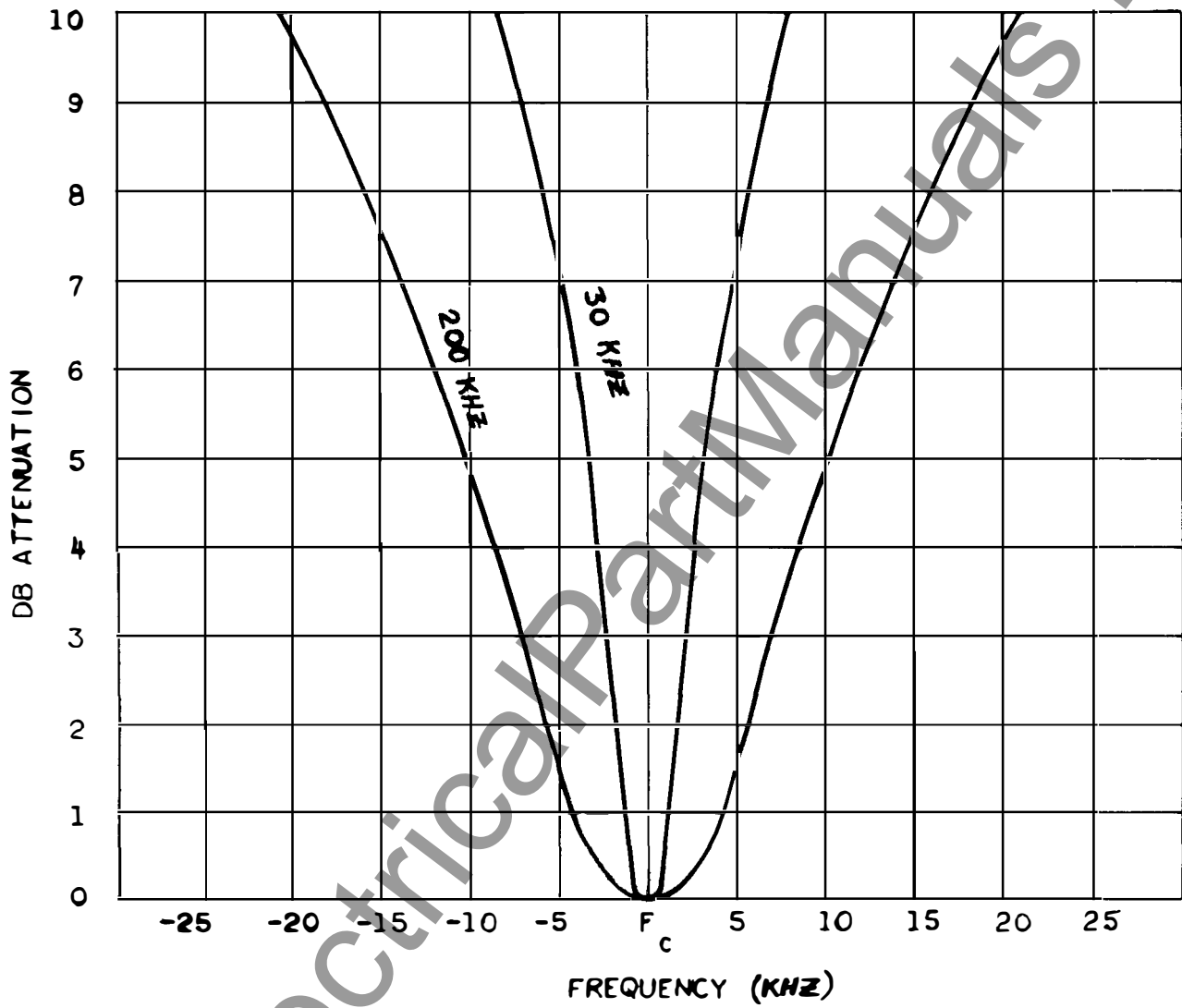

Fig. 10. Transmitter Output Filter Selectivity (Dwg. 377996)

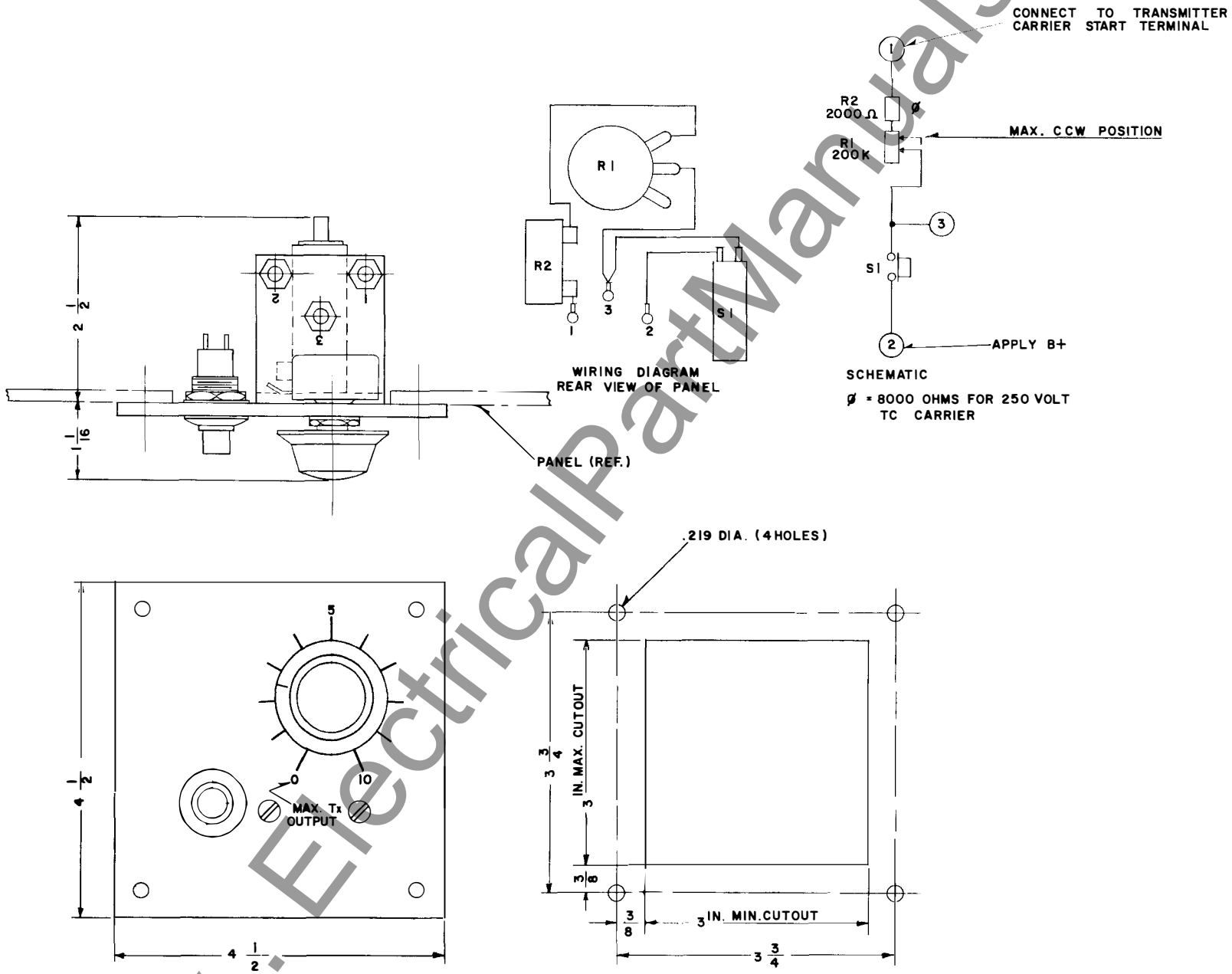

Fig. 11. Reserve Signal Detector Outline (Dwg. 329C703)

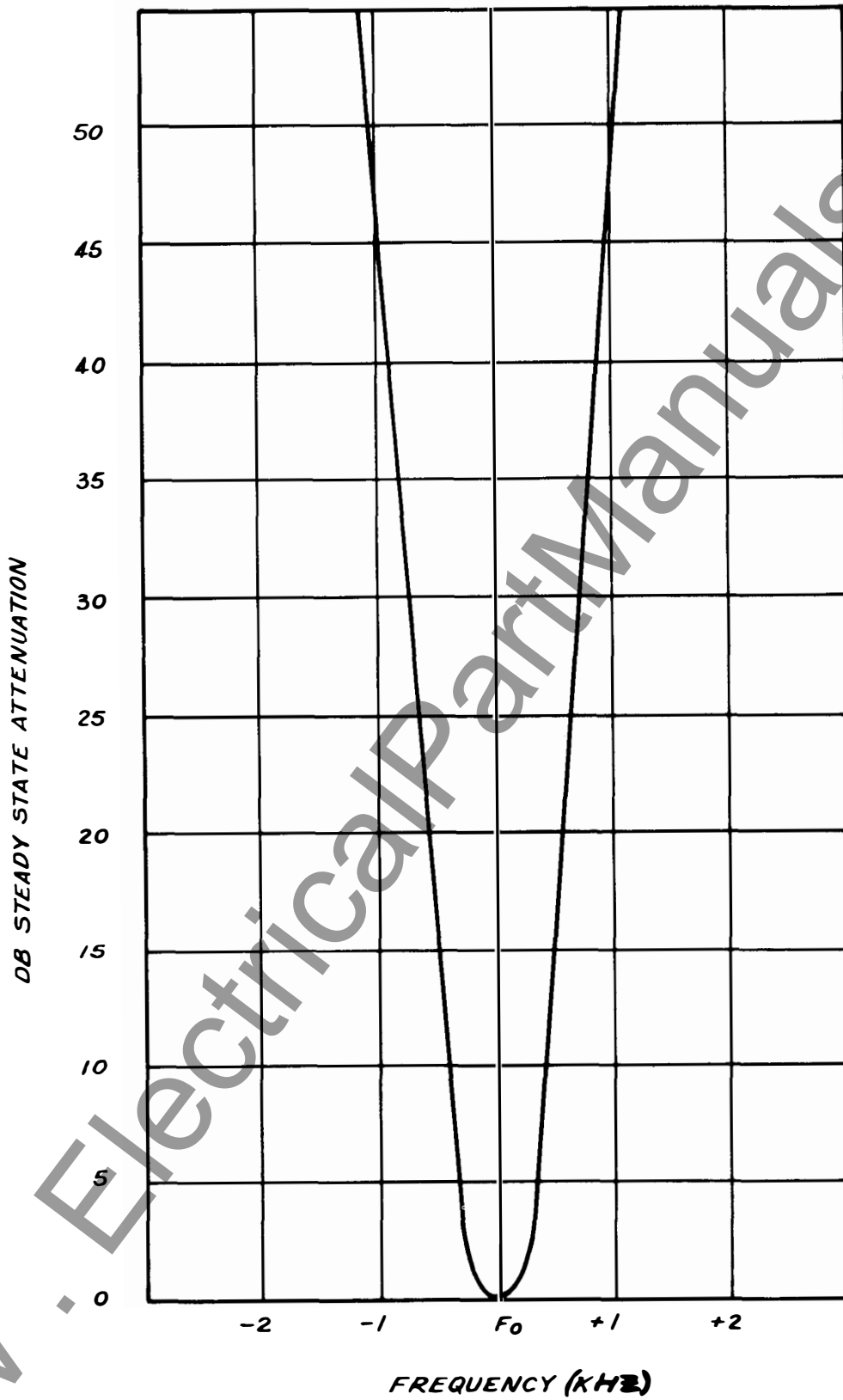
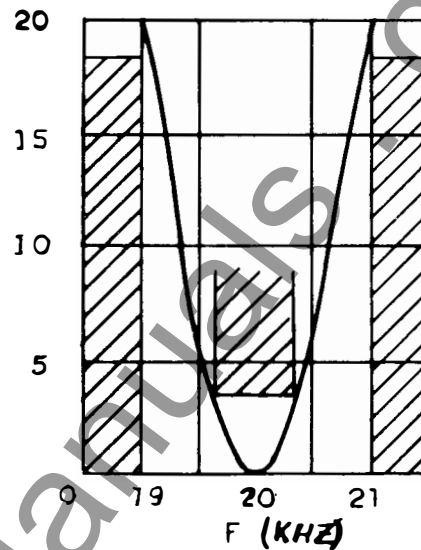
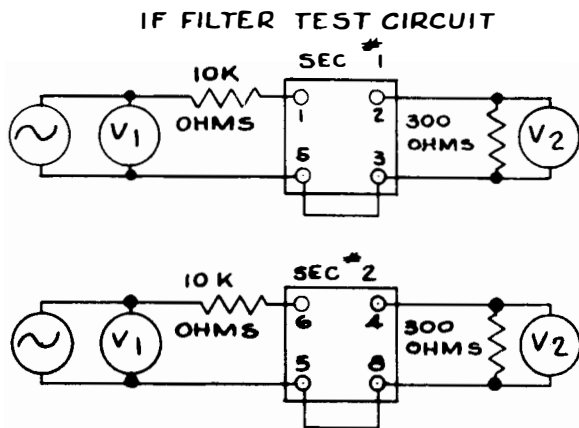

Fig. 12. Receiver Selectivity (Curve #377993)



Each section of FL-2 requirement with typical selectivity curve. Insertion loss 26 DB max. Including matching resistor.

FOR BOTH CURVES

$$DB = 20 \log \frac{V_1}{V_2}$$

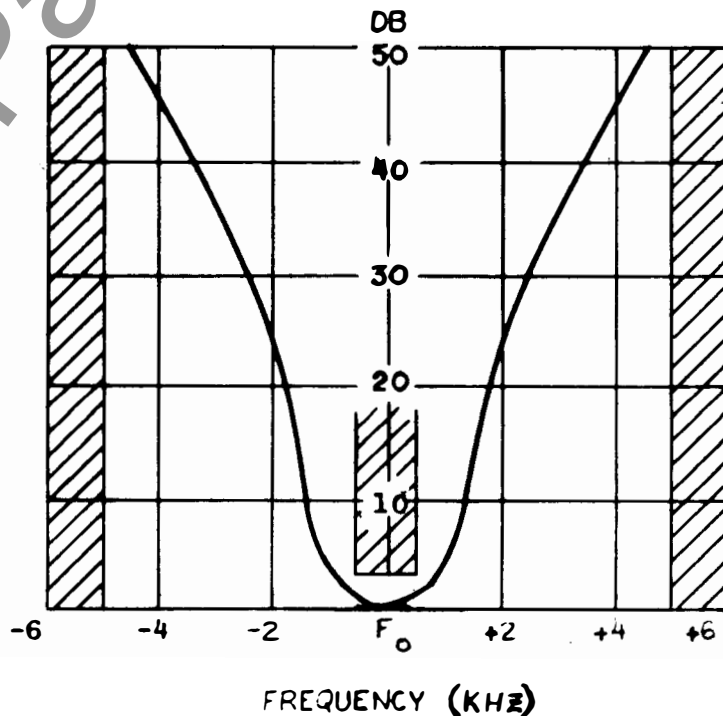
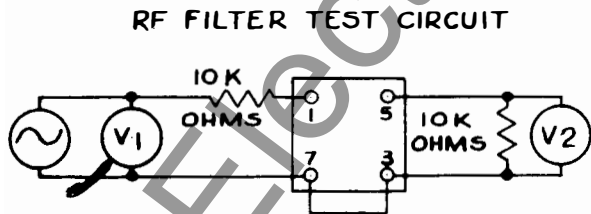

FL-1 Requirement with typical selectivity curve at 120 KHZ. Insertion loss 18 DB max. Including matching resistor.

Fig. 13. Receiver Filter Limits (Curve #377995)

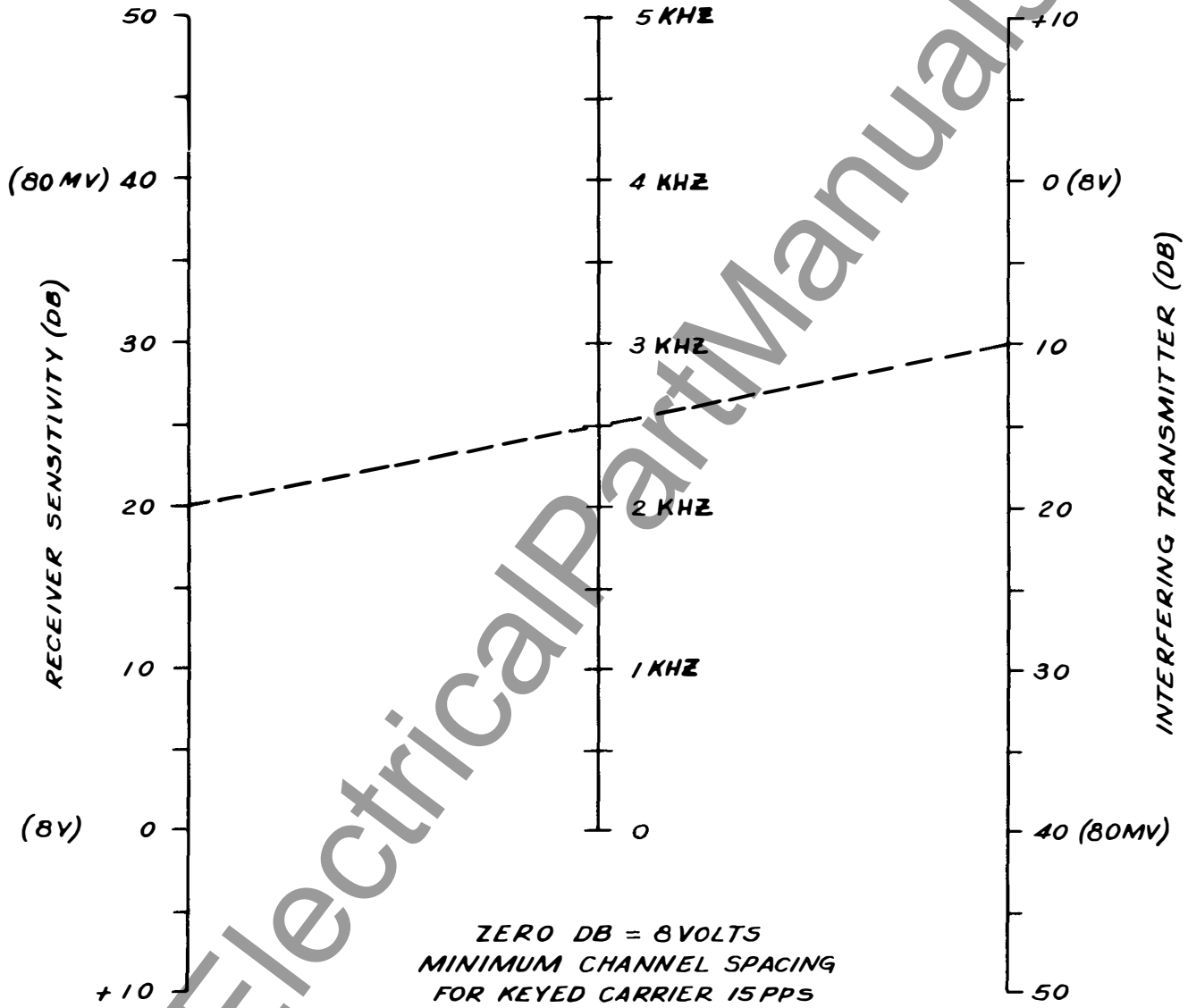
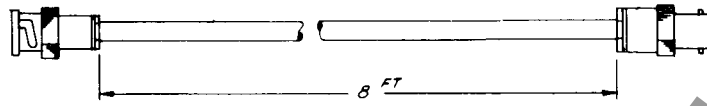
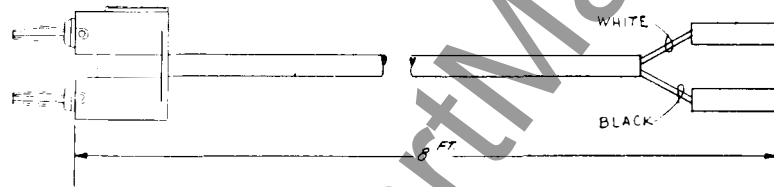

Fig. 14. Minimum Channel Spacing (Curve #377998)



Coaxial Lead... 756D346 G02



Output Lead... 756D346 G03

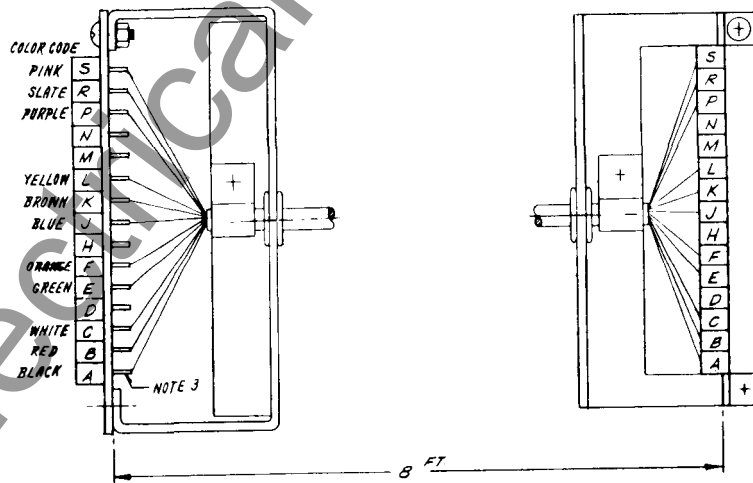

Main Harness... 756D346 G04

Fig. 15. Test Harness - (Complete Set)

www.ElectricalPartManuals.com

www.ElectricalPartManuals.com

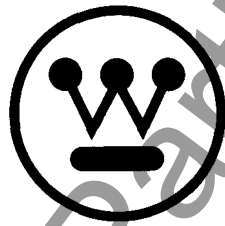

WESTINGHOUSE ELECTRIC CORPORATION
RELAY-INSTRUMENT DIVISION

NEWARK, N. J.

Printed in U.S.A.

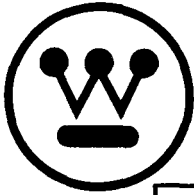

INSTALLATION • OPERATION • MAINTENANCE I N S T R U C T I O N S

TYPE KR CARRIER RELAYING TRANSMITTER-RECEIVER

Flexitest Case Mounted —with provision for rear-mounter Voice Adapter Accessories.	
	Style
KR Reserve Signal Detector	470D167 GO2
250 Volt Resistor Unit	330C191 H01
Test Harness (Complete Set)	756D346 G01
Coaxial Lead	756D346 G02
Output Lead	756D346 G03
Main Harness	756D346 G04

TABLE OF CONTENTS

Introduction	Page 2
Specifications	Page 2
Description	
General	Page 3
Mechanical	Page 3
Electrical	
Transmitter	Page 4
Receiver	Page 4
Transmitter Control Circuits	Page 5
Reserve Signal Detector	Page 5
Communications	Page 5
Relaying Control Circuits	Page 5
Installation	
General	Page 6
Connections	
External	Page 6
Internal	Page 7

Adjustments

Transmitter	Page 7
Receiver	Page 7
Reserve Signal Detector	Page 8
250-Volt Resistor Unit	Page 8
Frequency Change	Page 8
Maintenance	Page 9
Application	Page 13
Electrical Parts List	Page 14

LIST OF TABLES

Table

1 D-C Pin Jack Measurements with Reference to B-	Page 10
2 Transistor DC Measurements with Reference to B-	Page 11
3 D-C Bleeder Measurements with Reference to B-	Page 12
4 Typical RF Signal Measurements for Receiver	Page 12
5 Typical RF Signal Measurements for Transmitter	Page 13

LIST OF ILLUSTRATIONS

Figure	References
1 Outline – Flexitest Case	540D753
2 Internal Schematic	540D780
3 Relaying Control Circuits (HZ/HZM)	1-329C704
4 Relaying Control Circuits (K-Dar)	3-329C704
5 Relaying Control Circuits (GCX/GCY).....	2-329C704
6 Component Location.....	540D781
7 Supervisory Control Receiver Connection	223B498
8 Connections, 48-250 volts and Supervisory Control.....	407C971
9 Transmitter Output Filter Connections	149A420
10 Transmitter Output Filter Selectivity.....	C377996
11 Reserve Signal Detector – Outline and Schematic	329C703
12 Transmitter Output and Receiver Sensitivity Variations with D-C Voltage	C377999
13 Transmitter Output and Receiver Sensitivity Variations with Frequency.	C378000
14 Receiver Selectivity	C377993

15 Receiver Filter Limits	C377995
16 Minimum, Channel Spacing	C377998
17 Test Harness	756D346

CAUTION The voltages encountered in this equipment are dangerous to life. To be safe, disconnect the power source and close the grounding switch when servicing the equipment.

INTRODUCTION

The Type KR Relaying Transmitter-Receiver is designed for Distance Relaying, Telemetry, Supervisory Control and Sleet Detection. Facilities are provided for a plug-in type voice adapter. The basic design is for operation from 125-volt station batteries. However, the apparatus may also be operated from 48-volt or 250-volt station batteries by means of various internal connections. These various connections as well as most of the adjustments are made at the factory, although they can be changed in the field.

Although designed primarily for operation with Westinghouse protective relays, this apparatus may also be coordinated with other types of directional-distance relays and with most other contact keyed devices.

SPECIFICATIONS

Frequency Range.....	30-kHz to 200kHz	*
Channel Attenuation Rating	40-db	
Transmitter Power Output.....	1.0 watt at standard conditions (see Figs. 12 and 13). 0.5 watt with a 48-volt d-c supply.	
Transmitter Harmonic Output	At least 46-db below fundamental.	
Transmitter Output Impedance.....	Matches one 60-ohm coax. cable. (Suitable for 50-70 ohm cable.)	
Transmitter Output Filter Selectivity	See Fig. 10	
Transmitter and Receiver Oscillator and Frequency Stability	From -20° C to +50° C with simultaneous voltage variations from 100 to 140 VDC, the frequency remains with 0.01%.	

Permissible Battery Voltage Ripple	7-12%
Ambient Temperature Range	-20°C to +50°C.
Non-Operating Temperature Range	-40°C to +70°C
Receiver Sensitivity	0.04 volts at standard conditions (see Figs. 10 and 18).
Receiver Selectivity	See Fig. 14
Receiver Signal-to-Noise Ratio Requirements	12 db
Minimum Channel Spacing	See Fig. 16
Power Input	115-ma at 48 VDC, 200-ma at 125 VDC, 1.28 amperes at 250 VDC.
Carrier On-Off Keying	Requires one pair of contacts capable of keying 8-ma DC at an open circuit voltage of 125 VDC.
Weight (With Flexitest Case)	Approximately 16-lbs.

CAUTION Refer application to Westinghouse when other transmitters are to be connected to the same coax cable as certain conditions may result in damage to the output transistors.

* NOTE Standard conditions are taken as 129-volts, 120-kHz and 25°C.

DESCRIPTION

General

This completely transistorized carrier-apparatus is a result of extensive field and laboratory tests. From these tests, it was proven that transistors provide superior reliability over tubes. In addition, the latest printed circuit and filter techniques have improved performance and greatly decreased the size. The expected long life of transistors as compared with vacuum tubes will reduce maintenance costs, and the low power requirements will produce important savings in battery and charger requirements.

Transistors perform the same functions as vacuum tubes. However, tubes operate by the flow of electrons in a vacuum between elements, while transistors depend upon the movement of electrons in a solid. This leads to a more rugged type of construction. Most transistors are made from either germanium

or silicon semi-conductor materials. The junction transistor consists of a thin slice of germanium or silicon with three different regions produced by introducing specific amounts of impurities. A thin wire is connected to each region. One outer region is called the emitter, the other the collector, and inserted between them is the base. These correspond roughly to the cathode, plate, and grid of a vacuum tube.

The transistors in this equipment are of the junction type, and both NPN and PNP configurations are used. In the NPN transistor, the majority of the current is carried by electrons. In the PNP transistor there is a deficiency of electrons. These deficiencies are known as "holes". For practical purposes holes may be considered as positively charged "electrons", and these provide most of the current flow in PNP units. In order to obtain maximum efficiency and reliability, both types are used in this equipment.

Silicon transistors are used in the transmitter and receiver output circuit in order to stabilize critical circuit performance at elevated temperatures.

Mechanical

This apparatus is supplied in a Flexitest case and may be either flush or projection mounted in

order to match other switchboard equipment. The outline dimensions and also the drilling plan for flush and projection mounting are shown by Fig. 1. The majority of the parts are mounted on a printed circuit board. This board may be readily removed as follows:

1. Remove the two output plugs from the red and black jacks.
2. Disconnect the receiver input coaxial cable connector.
3. Loosen the two screws at the top of the board.
4. Loosen the two screws at the bottom of the board and pull them out as far as they will extend.
5. Pull board down to disengage the terminals and lift out.

The transmitter output filter may be removed by removing four mounting screws from the bottom of the case and disconnecting the coaxial cable.

Fig. 6. shows the location of major components such as potentiometers, jack, test points, crystals, transistors, etc. External connections and the Schematic Diagram are shown by Fig. 2. The numbered terminals shown as squares apply to the external terminals.

Provisions are made for plugging the Voice Adapter Unit in the rear of the relaying equipment. Octal socket marked X-4 on the rear of the set accommodates the adapter plug. A buckle type strap on each side of the adapter holds the unit in place after it has been plugged in. The normal projection for a rear mounted Voice Adapter is 3-inches beyond that of the relaying equipment. When the KR Relaying Unit is supplied with the adapter, a patch cord is available on separate order. This patch cord plugs into the telephone jacks on the adapter and provides an extension to a conveniently located terminal board.

The panel cutout information necessary for mounting the Reserve Signal Detector is shown by Fig. 11.

* This unit consists of a potentiometer and pushbutton switch mounted on a small panel, itself suitable for switchboard mounting.

For 250-volt operation, separate auxiliary resistors are required, as shown in Fig. 8.

Electrical

Transmitter

The transmitter is made of four main stages in-

cluding an oscillator, driver, power amplifier, and an output filter. In the oscillator, the crystal is operated as a resonant circuit between the collector of one transistor and the base of the other. The feedback is supplied through a capacitor from the collector of the second transistor to the base of the first transistor. The frequency is independent of voltage or temperature changes of the transistors. Thus the frequency stability is the stability of the crystal.

The input to the driver stage Q-10 is controlled by potentiometer, R-42 which also controls the transmitter power output. In HZM relaying CARRIER STOP provides about +40 volts for blocking. This is applied to Q-10 through T-6. Diode CR-5 prevents damage to the transistor when this positive voltage is applied to the collector. For CARRIER START (when in the blocked position) a small positive voltage is applied to the collector of Q-10 by means of bleeder resistors R-67 and R-68.

The power amplifier consists of two transistors Q-12 and Q-15, which are operated as class B amplifiers in push-pull. Resistors R-52 and R-55 are for stabilization.

The output transformer, T-7, matches coaxial cables of 50 to 70 ohms.

Resistor R-66 tends to keep the source impedance constant to permit proper tuning of the output filter.

The output filter consists of coils L-1 and L-2, capacitors C-19 through C-22. The filter is tunable, and is provided to attenuate harmonics and other spurious outputs. It should be noted that the filter contains no shunt elements, resulting in a reverse impedance free of "across the line" resonances.

Receiver

The receiver is a superheterodyne in order to obtain constant selectivity regardless of the channel frequency. (See Fig. 14.) The major stages include an input filter, attenuator, oscillator, mixer, IF filters, IF amplifiers, detector and a D-C power output stage.

The input filter prevents undesired signals from producing the IF frequency.

The receiver sensitivity is adjusted by means of the continuously variable input control R-1 and by

connecting or disconnecting resistors R-73 and R-74 in the IF stages.

The receiver oscillator (Q-2 and Q-3) is basically the same as the transmitter oscillator. The * frequency is 20-kHz above the incoming signal frequency.

The receiver channel frequency is determined by the input filter and the oscillator crystal. The frequency may be changed readily since both the filter and the crystal are plug-in components.

Mixing is accomplished by feeding the incoming signal to the emitter and the receiver oscillator signal to the base of the mixer Q-1. Mixer oscillator requirements are met through adjustment of potentiometer R-4. Injection into two separate elements, base and emitter, provides a circuit capable of handling greater signal level variations than one in which injection is made into only a single element such as the base.

This receiver uses an IF frequency of 20-kHz. The overall selectivity is determined primarily by the * IF filter FL-2. Typical characteristics of this filter are shown in Fig. 15.

The IF amplifier consists of transistors Q-4, Q-5 and Q-6.

The detector is a full wave bridge rectifier. This rectifier in conjunction with the IF amplifier Q-6, provides the necessary power to drive the DC power output stage Q-7.

The final output stage Q-7 will supply approximately 18 milliamperes to a standard 1700 ohm distance relay RRH coil and its associated 500 ohm alarm coil. It may also be used to drive other relay coils such as is shown by Fig. 7, Supervisory Control Connections.

Transmitter Control Circuits

In the standby condition, although the oscillator is running, the transmitter driver has no emitter bias which results in no output.

Positive voltage applied to terminal 15 supplies this bias through a voltage dividing network, and transmitter output results. The actual configuration of the network is a function of supply voltage and application (Relaying, Telemetering, etc.) and is

discussed in the Adjustments section.

Output may be stopped in several ways. The method used with K-DAR relays is to remove the positive voltage applied to terminal 15. In the case of distance relaying with Westinghouse HZ/HZM relays, application of a positive voltage to terminal 18 will stop the transmitter output. Output may also be stopped by removal of negative battery from terminal 18.

Reserve Signal Detector

The Reserve Signal Detector is shown by Fig. 11. Effectively R-1 is a remote transmitter output control. This control is obtained through varying the driver Stage (Q-10) emitter bias, and is effective over a 25-db range of transmitter output. The detector is switched into service by S 1. By adjusting R-1 for a given receiver relay current at the far end of the channel, a relative measure of the channel attenuation may be obtained. This is discussed further in the section on Adjustments.

Communications

The transmitter output is reduced approximately 6-db when the Type KR voice adapter attachment is used. Relaying takes preference, and full output is obtained since full voltage is supplied to terminal 15.

Relaying Control Circuits

Figs. 3, 4 and 5 show simplified diagrams of the relaying control circuits.

1. K-DAR and GCY Relaying (Figs. 4 and 5)

The control of the carrier set is obtained through the CARRIER START and CARRIER STOP contacts. These contacts are shown in their normal standby condition.

The K-DAR or GCY relays operating from the voltage and current on the transmission line, detect and determine the direction of a line fault and thereby control the carrier transmitter and receiver.

The control of the carrier set is such as to start the transmission of carrier when fault power on the transmission line is flowing out of the line section being protected. Conversely, when fault power is flowing into this line section, the control is such as to block the transmitter and keep it from being turned * on by secondary functions such as reserve signal de-

tection and communication, should these functions be in use at the same time. Should carrier be received from the remote station, the hold coil and alarm coil will energize through transistor Q-7 in the receiver.

When carrier start operation occurs, the CARRIER START contact opens applying a positive voltage (see Figs. 4 and 5) to terminal 15 of the carrier set. This puts a potential on the driver stage in the transmitter and also applies proper bias for the power amplifier.

When a carrier stop operation occurs, the CARRIER STOP contact closes, which removes B+ (terminal 15) from the driver and the power amplifier stages in the transmitter. CARRIER STOP, terminal 18, on the carrier set is permanently connected to terminal 14, for K-DAR and GCY relaying.

2. HZM Relaying (Fig. 3)

The control of the carrier set is effected by the CARRIER START and the CARRIER STOP contacts. These contacts are shown in their normal standby condition.

The HZ-HZM relays operating from the voltage and current on the transmission line, detect and determine the direction of a line fault and thereby control the carrier transmitter and receiver.

The control of the carrier set is such as to start the transmission of carrier when fault power on the transmission line is flowing out of the line section being protected. Conversely, when fault power is flowing into this line section, the control is such as to block the transmitter and keep it from being turned on by secondary functions such as reserve signal detection and communication, should these functions be in use at the same time. Should carrier now be received from the remote station, the hold coil and alarm coil will energize through transistor Q-7 in the receiver.

When carrier start operation occurs, the CARRIER START contact closes applying the full battery supply voltage to terminal 15 of the carrier set. This puts a potential on the driver stage in the transmitter and also applies proper bias for the power amplifier.

When a carrier stop operation occurs, the CARRIER STOP contact opens. This applies a positive voltage (see Fig. 3) to terminal 18 which blocks the driver stage and the power amplifier stage

It is possible under certain conditions that the signals from two transmitters, attempting to block a third receiver, would be of such amplitude, phase and frequency as to cause the RRH coil current to "pulsate". It would then be possible to have a false trip.

In the case of the KR set for relaying 3-terminal lines, the transmitter frequencies (to avoid this possibility of false trip) should be separated by 100 Hz. All receivers and one transmitter would be * for the desired center frequency. One of the other transmitters would be 100 Hz above, the other 100 Hz below this center frequency.

INSTALLATION

General

Upon receipt of a unit, whether shipped separately or in an assembly, an immediate inspection should be made. Carefully check for damage or shortages.

For necessary clearances and mounting dimensions, see the following illustrations:

- Flexitest Case Mounting..... Fig. 1
- * Reserve Signal Detector Fig. 11

Connections

External

The external connections will vary slightly depending on the application, but in general will be along the lines described as follows: (Refer to the Schematic Diagram, Fig. 2.)

- Terminals 11..... Ground
- 12..... Coaxial Cable
- 13 and 19 Supervisory Preference Contacts
- 14..... B- "CARRIER STOP" return
- 15..... Battery positive through carrier start contacts
- 16..... Battery positive for alarm cutoff (used with communication)
- 17..... B-
- 18..... Carrier Stop for HZM Relaying
- 19..... B+
- 20..... Relay Coil

CAUTION If the transmitter output load is removed while the transmitter is energized, the transistors in

the power amplifier will be permanently damaged. A dummy load should be connected to the transmitter output if the coax is disconnected and the transmitter is to be energized.

When tuning line coupling equipment, short the coaxial cable to ground before changing taps on the Line Tuner or matching transformer.

Internal

Necessary internal connections are generally made at the factory, to customer order, before apparatus shipment. For reference purposes, these are outlined in the following tabulation. Check the proper bleeder resistors before applying voltage to the equipment.

OPERATION	BLEEDER RESISTORS IN THE CIRCUIT
48-Volt K-DAR, HZM, and GCY Relaying, Telemetering, and Supervisory	R-47 and R-48
125-Volt K-DAR and GCY Relaying	R-45, R-47 and R-48
125-Volt HZM Relaying, Telemetering, and Supervisory	R-41, R-45, R-47 and R-48
250-Volt K-DAR and GCY Relaying	R-45, R-47 and R-48
250-Volt HZM Relaying, Telemetering, and Supervisory	R-39, R-40, R-41, R-45, R-47 and R-48

Various combinations of the inductors and capacitors of the transmitter output filter are required depending on the channel frequency. These are tabulated in Fig. 9.

Adjustments

This apparatus is generally tuned to and tested at the specified channel frequency before shipment. Final adjustments must be made in the field and are described in the following paragraphs. Fig. 6 shows the locations of the various controls.

Transmitter

1. Disconnect the coaxial cable and replace with a 50, 60, or 70 ohm non-inductive resistor depending on the characteristic impedance of the cable used.

2. Fig. 9 shows typical output filter connections for various frequency ranges. In some cases it may be necessary to use either a higher or lower range to tune the filter to resonance.

3. Insert fuses F-1 and F-2 to apply power to the apparatus.

4. Connect an A-C Vacuum Tube Voltmeter (VTVM) across the non-inductive load.

5. Unblock the transmitter by closing the CARRIER TEST SWITCH. An alternative is to jumper battery positive to terminal 15.

6. Beginning with the output control R-42 at the maximum counterclockwise position, advance it clockwise until a reading appears on the VTVM. Tune capacitor C-19 for a maximum voltmeter reading.

7. While increasing R-42, tune the output filter for maximum output until the output across the resistor is approximately 8 volts. (See Figs. 12 and 13.) (Approximately 5.5-volts when operating from 51-volt station battery.)

8. Open the test switch and reconnect the coaxial cable.

Receiver

1. The oscillator output control R-4 is pre-set at the factory. However, should any of the oscillator components be changed (including the transistors and the crystal) R-4 will require adjustment.

a. Connect an A-C VTVM to jacks J-3 and J-4.

b. Adjust R-4 for a 0.3 volt reading on the meter.

2. The unit is shipped to have a gain of approxi-

mately 250 millivolts (to produce 10 ma relay current) with input control R-1 in maximum clockwise position. About 10-db additional gain or 80 millivolt sensitivity can be obtained by clipping out resistor R-74, which is connected to the base of Q-4 and the B+ supply for the IF. Approximately 10-db gain or 25 millivolt sensitivity can be obtained by clipping out resistor R-73, which is connected to the base of Q-5 and the B+ supply for the IF. Resistor R-71 has been selected at the factory to provide an overall gain of approximately 25 millivolts.

a. Sensitivity Adjustment for Noise

If the maximum on-frequency noise level is known or can be measured, the receiver can be adjusted for this level. Disconnect the coaxial cable and connect a 60-ohm non-inductive resistor and a VTVM across terminals 11 and 12. Energize the transmitter and output control R-42 for the same output as the maximum noise. Then adjust the receiver input control R-1 to obtain 1-ma output current. If it is impossible to obtain 1-ma output current with control R-1 in the maximum clockwise position, then clip out resistor R-74, which is connected to the base of Q-4. If the gain is still insufficient, clip out resistor R-73, which is connected to the base of Q-5. After completing the adjustment of R-1, restore the transmitter to full output.

b. Sensitivity Adjustment for Remote Signal

When the maximum on-frequency noise is unknown and cannot be conveniently measured, the receiver may be adjusted for the remote signal. First determine the channel attenuation using a Sierra voltmeter or some other convenient method. Disconnect the coaxial cable and connect a 60-ohm non-inductive resistor and a VTVM across terminals 11 and 12. Add 15-db to the channel attenuation. This compensates for average variations such as channel and voltage variations. For example, if the channel attenuation is 5-db, add this to the 15-db making a total of 20-db. Taking this from 8 volts output of the transmitter, the receiver should then be set for a sensitivity of 0.8 volts. To do this, adjust the transmitter output control R-42 for 0.8 volts and then adjust the receiver input control so as to obtain 10-ma output current. If it is impossible to obtain 10-ma output current with control R-1 in the maximum clockwise position, clip out resistor R-74, which is connected to the base of Q-4. If the gain is still insufficient, clip out resistor R-73, which is connected to the base of Q-5. After completing the

adjustment of R-1, restore the transmitter to full output.

It must be kept in mind that the two preceding adjustment procedures are to be used as a guide and will cover the majority of cases; however, cases may arise where conditions change. For example, if the adjustment is made per part a., the noise may increase due to various reasons such as bad insulators, which would require adjusting the receiver to be less sensitive. In the adjustment of part b., the attenuation may increase due to sleet or line switching, which would necessitate increasing the sensitivity of the receiver.

Reserve Signal Detector

Due to different types of operation and supply voltages, it is not practical to have a calibrated dial for this unit. However, calibration may be made at installation by recording transmitter output (either in db or volts) at various knob settings of the detector unit. Then, by adjusting the knob so as to obtain 10 milliamperes relay current at a remote receiver, any increase or decrease in line attenuation may be noted as the difference between the original setting, and the setting required to obtain the given 10 milliamperes.

250-Volt Resistor Unit

With the apparatus energized, adjust R-4 in the 250-volt resistor unit so as to obtain 125-volts at terminals 17 (B-) and 19 (B+) on the relaying set.

Frequency Change

If the frequency is changed in the field, it is necessary to change the input filter FL-1 to the desired channel frequency. This filter is of the plug-in type and may be removed by unsnapping the clamp and pulling the filter out. The transmitter oscillator crystal Y-2 must be changed to the desired channel frequency. The receiver oscillator crystal Y-1 must be changed to the desired channel frequency plus 20 * kHz. Figure 9 shows the connections for the transmitter output filter. It is necessary to unsolder the existing connections and make the new connections per the chart. After completing the preceding, the tuning procedure as described under Adjustments for transmitter and receiver should then be followed.

Note also that capacitors C2 and C9 in the transmitter and receiver crystal oscillator circuits, respectively, may have to be changed. For fre-

- * frequencies below 110 kHz, these capacitors are 270 mmf. each. For frequencies of 110 kHz and above, the capacitors are 140 mmf. each.

CAUTION Turn power OFF before removing filters or transistors, as high transient currents may cause permanent damage to the transistors.

MAINTENANCE

Voltage values should be recorded after adjustment in order to establish reference values which will be useful when checking the apparatus. The readings will remain fairly constant over an indefinite period unless a failure occurs. However, if transistors are changed, there may be considerable difference in these readings without the overall performance being affected.

Typical voltage and current values are given as follows. Voltages should be measured with VTVM. Readings may vary as much as $\pm 20\%$.

In the following paragraphs, the transmitter may be unblocked (transmitting) by closing the CARRIER START circuit in the case of HZM relaying, and by opening the CARRIER START circuit in the case of K-DAR and GCY relaying.

1. For D-C pin jack measurements with reference to B-, refer to Table 1.

2. For transistor D-C measurements with reference to B-, refer to Table 2.

3. For D-C bleeder measurements with reference to B-, refer to Table 3.

4. For typical RF signal measurements for receiver, refer to Table 4.

5. For typical RF signal measurements for transmitter, refer to Table 5.

6. Removal of Printed Circuit Board from Flexitest Case.

To remove the printed circuit board, unplug J-15 and J-16 located near the output filter. Loosen the two screws inside the case near the top. Loosen the slotted thumb screws at the lower end of the board and pull these screws out as far as they will extend. Also remove the receiver coaxial cable plug.

Pull board down so as to disengage the terminals, and lift out.

7. Removal of the Output Filter

After the printed board has been removed, remove the screws on the outside of the case at the bottom. Lift out filter and disconnect the coaxial cable.

8. Receiver Filters

Fig. 15 shows typical receiver selectivity curves both RF and IF. If the filters are checked in a test setup, it is necessary to use an accurate signal generator or preferably a signal generator and a frequency counter.

9. Minimum Test Equipment for Installation

a. Milliammeter 0-25 ma DC.

b. 60-ohm 5-watt non-inductive resistor.

c. A-C Vacuum Tube Voltmeter (VTVM). Voltage * range 0.003 to 30 volts, frequency range 60 Hz to 230-kHz, input impedance 7.5 megohms.

d. D-C Vacuum Tube Voltmeter (VTVM)

Voltage Range: 0.15 to 300 volts

Input Impedance: 7.5 megohms

10. Desirable Test Equipment for Apparatus Maintenance

a. All items listed in Sections 8 and 9.

b. Signal Generator

Output Voltage: up to 8 volts

* Frequency Range: 20-kHz. to 230-kHz.

c. Oscilloscope

d. Ohmmeter

e. Capacitor checker

f. Test harness (See Fig. 17)

TABLE 1

D-C PIN JACK MEASUREMENTS WITH REFERENCE TO B-

Description	Jack	CONDITION A Tx-Blocked †† Rx-No Signal		CONDITION B Tx-Blocked Rx-With Signal		CONDITION C Tx-Unblocked Rx-No Signal	
		129 VDC	51 VDC	129 VDC	51 VDC	129 VDC	51 VDC
RF Input	J-2	0	0	0.3 V	0.3 V		
DC Q-1 Base	J-3	20 V	20 V	20 V	20 V		
DC R _x B+	J-4	20 V	20 V	20 V	20 V		
DC R _x Osc	J-5	7 V	7 V	7 V	7 V		
DC Q-5 Base	J-6	20 V	20 V	20 V	20 V		
B-	J-7						
DC-P1-E	J-8	110 V	32 V	110 V	32 V	110 V	32 V
DC-Q-7 Base	J-9	69 V	0 V	78 V	2.3 V	66 V	0.3 V
DC Q-7 Emit	J-10	70 V	1.0 V	78 V	1.4 V	66 V	1.0 V
DC T _x Osc	J-11	7 V	7 V	7 V	7 V	7 V	7 V
B+	J-12	129 V	51 V	129 V	51 V	129 V	51 V
DC Q-10 Base	J-13					18 V	18 V
DC Q-10 Emit	J-14					18 V	18 V
RF ma out	J-15					130 ma	130 ma
DC ma RRH and ALARM				18 ma	* 18 ma		

†† Tx = transmitter, Rx = receiver

TABLE 2

TYPICAL TRANSISTOR DC MEASUREMENTS WITH REFERENCE TO B-

Transistor	Condition A Tx-Blocked Rx-No Signal (Volts)			Condition B Tx-Blocked Rx-With Signal (Volts)			Condition C Tx-Unblocked Rx-No Signal (Volts)		
	E†	B†	C†	E†	B†	C†	E†	B†	C†
Q-1	20.0	20.0	0.38	20.0	20.0	0.4			
Q-2	7	7.2	1.8	7	7.2	1.8			
Q-3	6.2	8.0	2	6.2	8	2.0			
Q-4	20.0	20.0	2.6	20.0	20.0	2.8			
Q-5	20.0	20.0	2.6	20.0	20.0	2.8			
Q-6									
129 VDC	110	110	129	115	114	129			
51 VDC	32	32	51	32	32	51			
Q-7									
129 VDC	70	68	129	78	80	86			
51 VDC	1.0	0	51	1.4	2.2	7.0			
Q-8	6.2	8	2	6.2	8	2	6.2	8	2
Q-9	7	7.2	1.8	7	7.2	1.8	7	7.2	1.8
Q-10††							18	18	0.4
Q-12††							0.27	0.20	50
Q-15††							0.27	0.20	50

† E-Emitter; B-Base; C-Collector.

†† With respect to term F' on printed board.

TABLE 3

D-C BLEEDER MEASUREMENTS WITH REFERENCE TO B-

Measurement	129 VDC			51 VDC		
	A†	B†	C†	A†	B†	C†
Junction R-61 and R-62 (J-8)	110V	110V	110V	32V	32V	32V
Junction R-61 and R-27 (J-10)	70V	78V	66V	1.0V	1.4V	1.0V
Junction R-27 and R-60 (P1-P)	69V	77V	65V	0	0	0
Junction CR-8 and R-64 (P1-K)	58V	58V	58V	51V	51V	51V
Junction R-48 and R-47 (J-14)	—	—	18V	—	—	18V
Junction R-45 and R-47 (TP-9)	—	—	45V	—	—	51V
Junction R-45 and R-41 (TP-8)	—	—	98V	—	—	51V

†Conditions: A — Tx-Blocked, Rx-No Signal; B — Tx-Blocked, Rx-With Signal; C — Tx-Unblocked, Rx-No Signal.

TABLE 4
TYPICAL RF SIGNAL MEASUREMENTS FOR RECEIVER
(Made with 0.1 Volt at Terminal 5 of FL1)

Check Point	25 MV Sensitivity (Volts)	80 MV Sensitivity (Volts)	250 MV Sensitivity (Volts)
With Receiver Crystal Out			
FL1-5 to Gnd.	0.1	0.1	0.1
T1-1 to Gnd.	0.1	0.1	0.1
Q1-E to Gnd.	0.05	0.05	0.05
Q1-C to Gnd.	0.07	0.07	0.07
T3-1 to Gnd.	0.07	0.07	0.07
Q4-C to Gnd.	0.07	0.07	0.07
With Receiver Crystal In			
Q4-C to Gnd.	0.5	0.5	0.25
J6 to Gnd.	0.15	0.1	0.08
Q5-C to Gnd.	7.0	1.7	0.8
Q6-B to Gnd.	2.0	0.5	0.4
Q6-C to Gnd.	13.0	10.0	8.0
T4-1 to Gnd.	13.0	10.0	8.0
T4-3 to T4-4	4.5	3.5	2.5
J9 to J10 (DC)	0.74	0.75	0.65

TABLE 5

TYPICAL RF SIGNAL MEASUREMENTS FOR TRANSMITTER	
CHECK POINT	VOLTS
T5-1 to Gnd.	5.5
T5-3 to Gnd.	1.0
J13 to Gnd.	0.085
Q10-C to Gnd.	6.0
T6-2 to Gnd.	6.0
Q12-B to Gnd.	0.8
Q15-B to Gnd.	0.8
Q12-C to Gnd.	38.0
Q15-C to Gnd.	38.0
T7-5 to Gnd.	9.8
Output to Gnd.	8.0

APPLICATION

1. Receiver Selectivity (Fig. 14)

This shows a typical curve of the overall selectivity of the receiver under steady state conditions.

2. Transmitter Output Selectivity (Fig. 10)

Typical curves are shown so that approximate bandwidths for keying purposes can be determined for any carrier frequency between 30-kHz and 200-kHz.

3. Minimum Channel Spacing (Fig.16)

This is a graph from which minimum channel spacing can be obtained provided the signal strength of the interfering transmitter and the sensitivity setting of the receiver are known. These can be obtained from calculations or by measurements.

For example, if the interfering transmitter voltage is measured (at the receiver) and found to be 2.5

volts, this would be 10-db down from 8 volts. This point can be located on the right hand column of the graph. Then, if the receiver sensitivity were set to operate on 0.8 volts or 20-db, this point would be located on the left hand column. A line could then be drawn through the two points as shown by the dotted line. The intersection of this line with the center line indicates the minimum channel spacing. In this case if the interfering signal is being keyed on-off, at * 15 pps, the minimum spacing would be 2.5-kHz.

4. Transmitter Output and Receiver Sensitivity Variations with Voltage (Fig. 12)

These curves show the variation of transmitter output and receiver sensitivity with changes in supply * voltage, at 120-kHz and 25°C. The increase and decrease in transmitter output above or below 1.0 watts may be obtained in db from the transmitter curve. 1.0 watts is about 8.0 volts with a 60-ohm load.

The increase and decrease in receiver sensitivity above or below 40 millivolts can similarly be

TYPE KR CARRIER SET

obtained in db from the receiver curve. 40 millivolts sensitivity represents the input signal required for proper operation.

5. Transmitter Output and Receiver Sensitivity Variations with Frequency (Fig. 13)

These curves show the variation of transmitter output and receiver sensitivity with variation in frequency, at a supply voltage of 129 VDC, and 25°C. They may be used in the same manner as Fig. 12.

6. Supervisory Control Connections (Fig. 7)

When supervisory control is used with relaying, the supervisory control relay coil is connected in

series with the RRH coil in place of the alarm relay. When supervisory control is used alone, a 1200-ohm resistor R3 is connected in series with the control relay coil by removing the jumper across R3, as shown in Fig. 7. In order to maintain proper mark space ratio, the relay bias current is adjusted for 9 milliamperes as indicated.

The receiver RF filter and the IF filter limits are shown on Fig. 15. Both filters are of the plug-in type and the test circuits with pin connections are shown at the top of each curve. The IF filter is divided into two separate sections. The selectivity shown is for each section, and the pin connections for each section are also shown in the test circuit sketch.

ELECTRICAL PARTS LIST

CIRCUIT SYMBOL	FUNCTION	DESCRIPTION	MANUFACTURER'S DESIGNATION
<u>CAPACITORS</u>			
C-1	Rcvr. Bleeder	2.0 μ f, \pm 20%, 200 VDC, Paper	330C567 H11
†C-2	Rcvr. Osc. Feedback	140/270 μ f, \pm 20%, 500 VDC, Mica	330C566 H43 or 330C566 H57
C-3	Rcvr. Osc. Bleeder Bypass	0.02 μ f, MRC, 600 VDC, Disc	330C569 H47
C-5	Q-6 Emitter Bypass	1.0 μ f, \pm 20%, 200 VDC Paper	330C567 H09
C-6	Rcvr. Rectifier Bypass	Same as C-5	
C-7	B- to B+ Bypass	2 μ f, \pm 10%, 600 VDC, Paper	14C9400 H18
C-8	B- to GND	1.0 μ f, \pm 10%, 1000 VDC, Paper	14C9400 H17
†C-9	Xmtr. Osc. Feedback	Same as C-2	
C-10	Xmtr. Osc.	Same as C-3	
C-11	Key Filter	0.1 μ f, \pm 20%, 200 VDC, Paper	330C567 H02
C-12	Q-10 Emitter Bypass	0.25 μ f, \pm 20%, 200 VDC, Paper	330C567 H05
C-13	Q-10 Bleeder Bypass	Same as C-12	
C-14	PA Base Bypass	Same as C-12	

†Note: 140 μ f for osc. freq. 110-kc and above.
270 μ f for osc. freq. below 110-kc.

ELECTRICAL PARTS LIST

CIRCUIT SYMBOL	FUNCTION	DESCRIPTION	MANUFACTURER'S DESIGNATION
<u>CAPACITORS (Concluded)</u>			
C-18	PA Bleeder	0.5 μf , $\pm 20\%$, Paper	330C567 H06
C-19	Output Filter Tuning	500 μf , Variable, Air	328C092 H01
C-20	Output Filter	390 μf , $\pm 5\%$, 2500 VDC, Mica	330C561 H15
C-21	Output Filter	680 μf , $\pm 5\%$, 2500 VDC, Mica	330C561 H21
C-22	Output Filter	1200 μf , $\pm 5\%$, 2500 VDC, Mica	330C561 H27
C-24	FL-2 Decoupling	Same as C-12	
C-25	Q-7 Emitter	12 mfd, $\pm 20\%$, 200 VDC	187A177 H01
<u>CRYSTAL DIODES</u>			
CR-1	Bridge Rectifier	General Purpose, 1N63	584C433 H02
CR-2	Bridge Rectifier	Same as CR-1	
CR-3	Bridge Rectifier	Same as CR-1	
CR-4	Bridge Rectifier	Same as CR-1	
CR-5	Q-10 Collector	Same as CR-1	
CR-6	Q-7 Base-Emitter	Type 1N457A	184A855H07
CR-7	Voltage Regulator	Type 1N768,	584C434 H02
CR-8	Voltage Regulator	Type 1N1369	584C434 H05
CR-9	Q-7 Collector	Type 1N3811	185A089H08
CR-10	Q10 Emitter	Type 1N3028A	188A302H14

ELECTRICAL PARTS LIST

CIRCUIT SYMBOL	FUNCTION	DESCRIPTION	MANUFACTURER'S DESIGNATION
<u>FUSE HOLDERS</u>			
FH-1	B-	For Type 3AGC Fuses	584C271 H02
FH-2	B+	Same as FH-1	
<u>FUSES</u>			
F-1	B-	3AGC 3/4 amp.	S#330C691 H12
F-2	B+	Same as F-1	
<u>FILTERS</u>			
FL-1	Rcvr. RF Bandpass	* 30 to 200 kHz Freq. to be specified by customer	
FL-2	Rcvr. IF Bandpass	* 20-kHz Fixed Freq.	
<u>CONNECTORS</u>			
J-1	Printed Circuit	Printed Circuit Female Plug	54-B-7125 H03
J-2	RF Input	UG-185-U	584C292 H07
J-3	Rcvr. Osc. Output	Terminal Studs	330C592 H01
J-4	Rcvr. Mixer-Amp Supply	Same as J-3	
J-5	Rcvr. Osc. Supply	Same as J-3	
J-6	Q-5 Base	Same as J-3	
J-7	B-	Same as J-3	
J-8	Q-6 Supply	Same as J-3	

ELECTRICAL PARTS LIST

CIRCUIT SYMBOL	FUNCTION	DESCRIPTION	MANUFACTURER'S DESIGNATION
<u>CONNECTORS (Concluded)</u>			
J-9	Q-7 Base	Same as J-3	
J-10	Q-7 Emitter	Same as J-3	
J-11	Xmtr. Osc. Supply	Same as J-3	
J-12	B+	Same as J-3	
J-13	Xmtr. Osc. Output	Same as J-3	
J-14	Q-10 Supply	Same as J-3	
J-15	Output Filter	Banana Tip Red	328C093 H01
J-16	Output Filter GND	Banana Tip Black	328C093 H02
P-1	Printed Circuit	Printed Circuit Male Plug	54-B-7126 H03
<u>INDUCTORS</u>			
L-1	Core and Coil Assembly	11 MH Total – 6 MH Tap (Part of FL-3)	329C450
L-2	Core and Coil Assembly	2.5 MH (Part of FL-3)	329C449
L-3	RF Choke	1.0 MH, 300 ma	R-300
L-4	RF Choke	Same as L-3	
<u>TRANSISTORS</u>			
Q-1	Rev. Mixer	Type 2N525	184A638H13
Q-2	Rcvr. Osc.	Type 2N414	184A638H14

ELECTRICAL PARTS LIST

CIRCUIT SYMBOL	FUNCTION	DESCRIPTION	MANUFACTURER'S DESIGNATION
		<u>TRANSISTORS (Concluded)</u>	
Q-3	Rcvr. Osc.	Same as Q-2	
Q-4	Rcvr. IF	Same as Q-1	
Q-5	Rcvr. IF	Same as Q-1	
Q-6	Rcvr. IF	Type 2N498 or Type 2N657	184A638H15 184A638H15
Q-7	Rcvr. Output	Type 2N698	762A585H02
Q-8	Xmtr. Osc.	Same as Q-2	
Q-9	Xmtr. Osc.	Same as Q-2	
Q-10	Xmtr. Amp.	Same as Q-1	
Q-12	Xmtr. PA	Type 2N498 or Type 2N657	184A638H07 184A638H15
Q-15	Xmtr. PA	Same as Q-12	
		<u>RESISTORS</u>	
R-1	Rec. Input	25 K, $\pm 20\%$, 1/4 W, Pot.	584C276 H23
R-2	Filter Matching	10 K, $\pm 10\%$, 1/2 W	330C595 H37
R-3	Filter Load	Same as R-2	
R-4	Rcvr. Osc.	1 K, $\pm 20\%$, 1/4 W, Pot.	584C276 H19
R-5	Rcvr. Voltage Divider	6.2 K, $\pm 5\%$, 1 W	330C666 H68
R-6	Q-2 Collector	1.2 K, $\pm 5\%$, 1/2 W	330C664 H51
R-8	Rcvr. Voltage Divider	30 K, $\pm 5\%$, 2 W	330C668 H84
R-9	Rcvr. Voltage Divider	Same as R-8	

ELECTRICAL PARTS LIST

CIRCUIT SYMBOL	FUNCTION	DESCRIPTION	MANUFACTURER'S DESIGNATION
		<u>RESISTORS (Continued)</u>	
R-10	Q-2 Base	Same as R-2	
R-11	Q-2 Base	100 K, $\pm 5\%$, 1/2 W	330C665 H05
R-12	Q-3 Collector	Same as R-6	
R-13	Q-3 Emitter	390 Ohms, $\pm 5\%$, 1/2 W	330C664 H39
R-14	Q-3 Base	Same as R-2	
R-15	Q-3 Base	Same as R-11	
R-16	Rcvr. Osc. Bleeder	2.2 K, $\pm 10\%$, 1/2 W	330C595 H41
R-17	Rcvr. Osc. Bleeder	18 K, $\pm 10\%$, 2 W	330C597 H40
R-18	Rcvr. Osc.	9.1 K, $\pm 5\%$, 1/2 W	330C664 H72
R-19	Q-4 Bias	100 Ohms, $\pm 5\%$, 1/2 W	330C664 H25
R-20	Q-4 Bias	Same as R-2	
R-21	Q-5 Bias	150 Ohms, $\pm 5\%$, 1/2W	330C664 H29
R-22	Q-5 Bias	Same as R-2	
R-23	Q-6 Bias	330 Ohms, $\pm 5\%$, 1/2 W	330C664 H37
R-24	Q-6 Bias	Same as R-2	
R-25	Q-6 Emitter	Same as R-19	
R-26	Q-7 Base	Same as R-6	
R-27	Q-7 Bias	20 Ohms, $\pm 5\%$, 1/2 W	330C664 H08
R-28	Xmtr. Osc. Bleeder	Same as R-18	
R-29	Xmtr. Osc. Bleeder	Same as R-17	
R-30	Xmtr. Osc. Bleeder	Same as R-16	

ELECTRICAL PARTS LIST

CIRCUIT SYMBOL	FUNCTION	DESCRIPTION	MANUFACTURER'S DESIGNATION
		<u>RESISTORS (Continued)</u>	
R-31	Q-8 Base	Same as R-11	
R-32	Q-8 Base	Same as R-2	
R-33	Q-8 Emitter	Same as R-13	
R-34	Q-8 Collector	Same as R-6	
R-35	Q-9 Base	Same as R-11	
R-36	Q-9 Base	Same as R-2	
R-37	Q-9 Collector	Same as R-6	
R-38	Key Filter	Same as R-23	
R-39	Buffer Voltage Divider	36 K, $\pm 5\%$, 2 W	330C668 H86
R-40	Buffer Voltage Divider	Same as R-39	
R-41	Buffer Voltage Divider	Same as R-2	
R-42	Xmtr. Osc. Output	Same as R-4	
R-43	Q-10 Bias	Same as R-23	
R-44	Q-10 Bias	33 K, $\pm 5\%$, 1/2 W	330C664 H85
R-45	Buffer Voltage Divider	15 K, $\pm 10\%$, 1 W	330C596 H39
R-47	Buffer Voltage Divider	6.8 K, $\pm 5\%$, 1/2 W	330C664 H69
R-48	Buffer Voltage Divider	15 K, $\pm 5\%$, 1/2 W	330C664 H77
R-49	PA Bias	27 K, $\pm 5\%$, 2 W	330C668 H83

ELECTRICAL PARTS LIST

CIRCUIT SYMBOL	FUNCTION	DESCRIPTION	MANUFACTURER'S DESIGNATION
		<u>RESISTORS (Concluded)</u>	
R-50	Xmtr. PA	Same as R-19	
R-52	Q-12 Emitter	10 Ohms, $\pm 5\%$, 1/2 W	330C664 H01
R-55	Q-15 Emitter	Same as R-52	
R-59	Xmtr. Bleeder	47 Ohms, $\pm 10\%$, 1/2 W	330C595 H09
R-60	Recvr. Bleeder	1 K, $\pm 5\%$, 25 W	584C416 H57
R-61	Recvr. Bleeder	600 Ohms, $\pm 5\%$, 25 W	584C416 H47
R-62	Recvr. Bleeder	350 Ohms, $\pm 5\%$, 25 W	584C416 H52
R-64	Xmtr. Bleeder	1200 Ohms, $\pm 5\%$, 25 W	584C416 H64
R-66	T-7 Load	560 Ohms, $\pm 5\%$, 2 W	330C668 H43
R-67	Xmtr. Blocking	10 Ohms, $\pm 5\%$, 2 W	330C668 H01
R-68	Xmtr. Blocking	10 K, $\pm 10\%$, 10 W	330C577 H01
R-69	Q-10 Emitter	Same as R-19	
R-70	FL2 Decoupling	470 Ohms, $\pm 10\%$, 1/2 W	330C595 H21
R-71	Q-4 Emitter	150 Ohms, $\pm 10\%$, 1/2 W	330C595 H15
R-72	Q-5 Emitter	68 Ohms, $\pm 10\%$, 1/2 W	330C595 H11
R-73	Q-5 Base	180 Ohms, $\pm 10\%$, 1/2 W	330C595 H16
R-74	Q-4 Base	2.7 K, $\pm 5\%$, 1/2 W	330C664 H59
R-75	Q-4 Collector	22 K, $\pm 10\%$, 1/2 W	330C595 H41
R-76	Q-5 Collector	Same as R-75	

ELECTRICAL PARTS LIST

CIRCUIT SYMBOL	FUNCTION	DESCRIPTION	MANUFACTURER'S DESIGNATION
<u>TRANSFORMERS</u>			
T-1	Rcvr. Input	Impedance Ratio 10 K; 10K	S#1962798, L-633005
T-2	Rcvr. Osc.	Impedance Ratio 10 K: 400 ohms	S#1962797, L-633003
T-3	Rcvr. Mixer	Impedance Ratio 25 K: 300 ohms	S#1962697, L-592171
T-4	IF Output	Impedance Ratio 4 K: 500 ohms	S#1962693, L-592289
T-5	Xmtr. Osc.	Same as T-2	
T-6	Xmtr. Buffer	Impedance Ratio 10 K: 400 ohms CT	S#1962698, L-592170
T-7	Xmtr. Output	Impedance Ratio 1930: 60	S#1962694, L-633000
<u>TEST POINTS</u>			
TP-1	R-5	Terminal studs	330C592 H02
TP-2	R-8	Same as TP-1	
TP-3	R-17	Same as TP-1	
TP-4	R-18	Same as TP-1	
TP-5	R-28	Same as TP-1	
TP-6	R-39 & R-40	Same as TP-1	
TP-7	R-41	Same as TP-1	
TP-8	R-45	Same as TP-1	
TP-9	R-47	Same as TP-1	

ELECTRICAL PARTS LIST

CIRCUIT SYMBOL	FUNCTION	DESCRIPTION	MANUFACTURER'S DESIGNATION
		<u>SOCKETS</u>	
X-1	FL-1	Octal	330C689 H01
X-2	FL-2	Same as X-1	
X-4	Rear Mounted Voice Adaptor	Same as X-1	
XY-1	Rec. Y-1	Crystal	584C606 H01
XY-2	Xmtr. Y-2	Same as XY-1	
		<u>CRYSTALS</u>	
Y-1	Revr. Osc.	Specify Channel Freq. * Plus 20-kHz.	328C083
Y-2	Xmtr. Osc.	Specify Freq. Same as Channel Frequency	328C083
		<u>RESERVE SIGNAL DETECTOR</u> (S#470D167G02)	
R-1	Resistor, Level Control	* 200 K, 2 W, Pot.	* 184A086H27
R-2	Resistor, Limiting	2000 ohms, 2" tube.	1267296
S-1	Test Switch	SPST Normally Open	327C854 H01

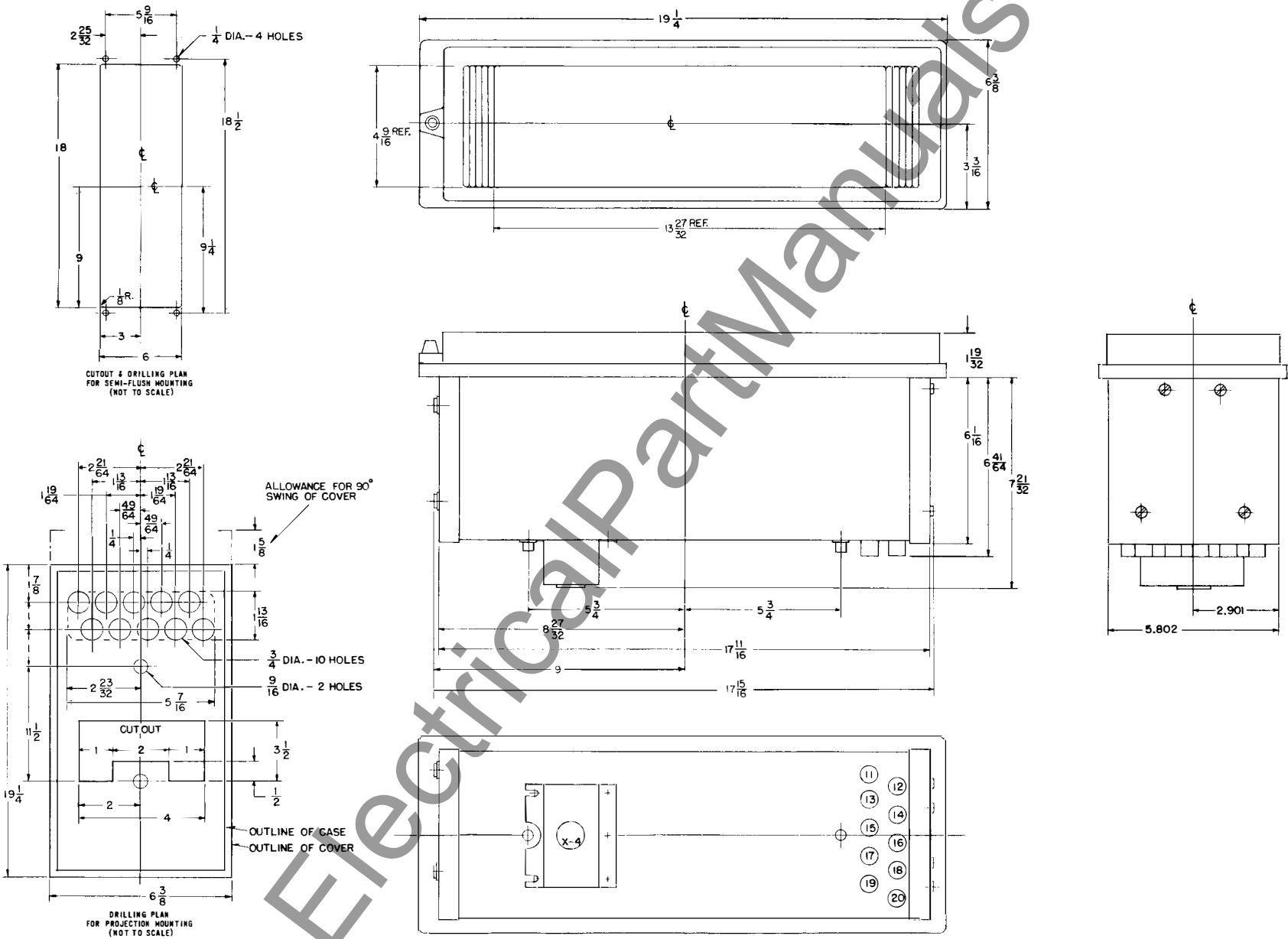
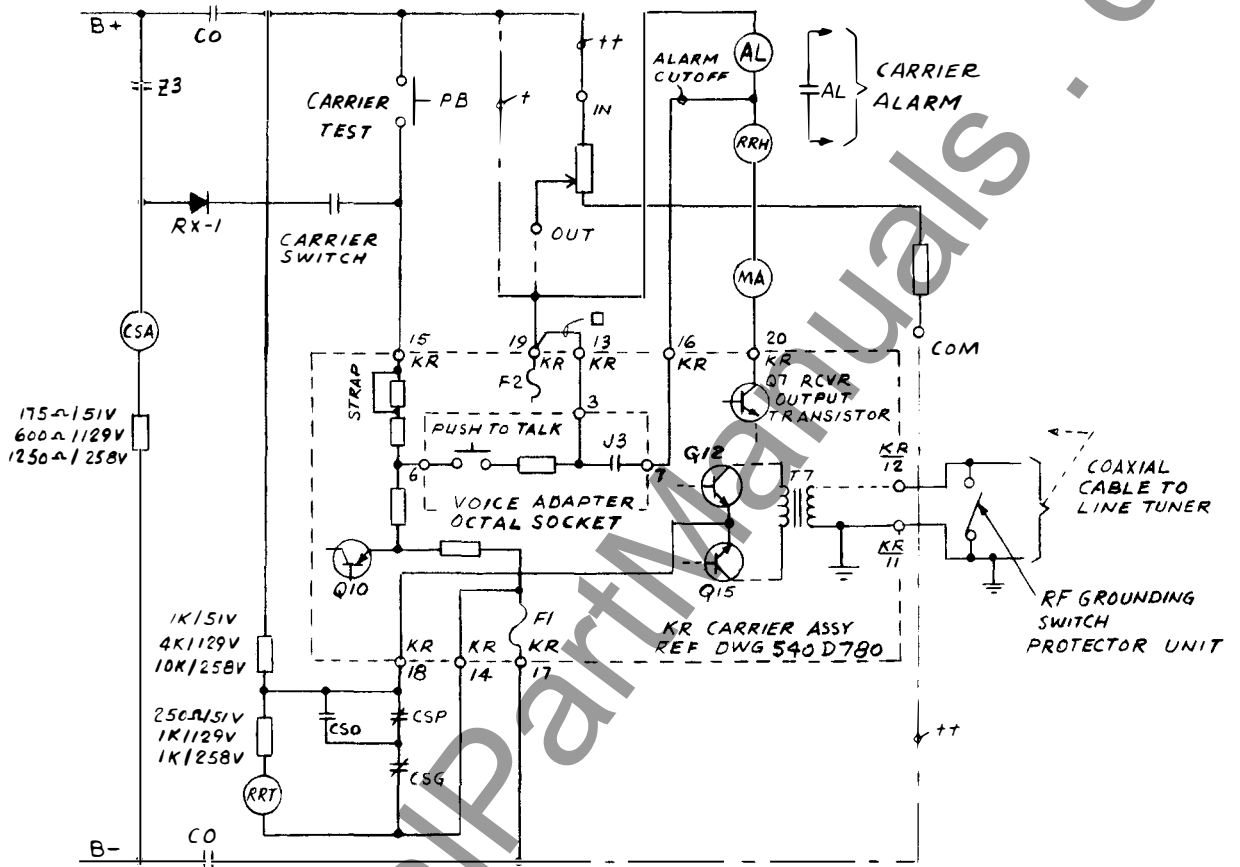

Fig. 1 Outline Drawing, (Flexitest Case) (540D753)

TYPE KR CARRIER SET



REQUIREMENTS FOR HZ/HZM RELAYING

SUPPLY VOLTAGE	CARRIER START	CARRIER STOP	STRAP
51VDC	+51V, 7MA	+28V	IN
129VDC	+129V, 8MA	+40V	IN
258VDC	+258V, 8MA	+40V	OUT

- NOTES
- + FOR 51 & 129 VDC SUPPLY.
 - ++ FOR 258 VDC SUPPLY USE 330C191H01 RESISTOR UNIT REF DWG 223B497
 - FOR SUPERVISORY CONTROL PREFERENCE CONTACTS.

- KR RELAYING TRANSMITTER / RELY EXTERNAL CONNECTIONS
- TERMINAL CONNECTION
- 11 GROUND
 - 12 COAXIAL CABLE
 - 13 SUPERVISORY PREFERENCE CONTACT
 - 14 CARRIER STOP B- RETURN
 - 15 CARRIER START (POSITIVE)
 - 16 ALARM CUTOFF FOR COMMUNICATIONS
 - 17 B MINUS
 - 18 CARRIER STOP (HZ/HZM)
 - 19 B PLUS
 - 20 RELAY COIL

Fig. 3- Relaying Control Circuits - HZ/HZM (Dwg. 1-329C704)

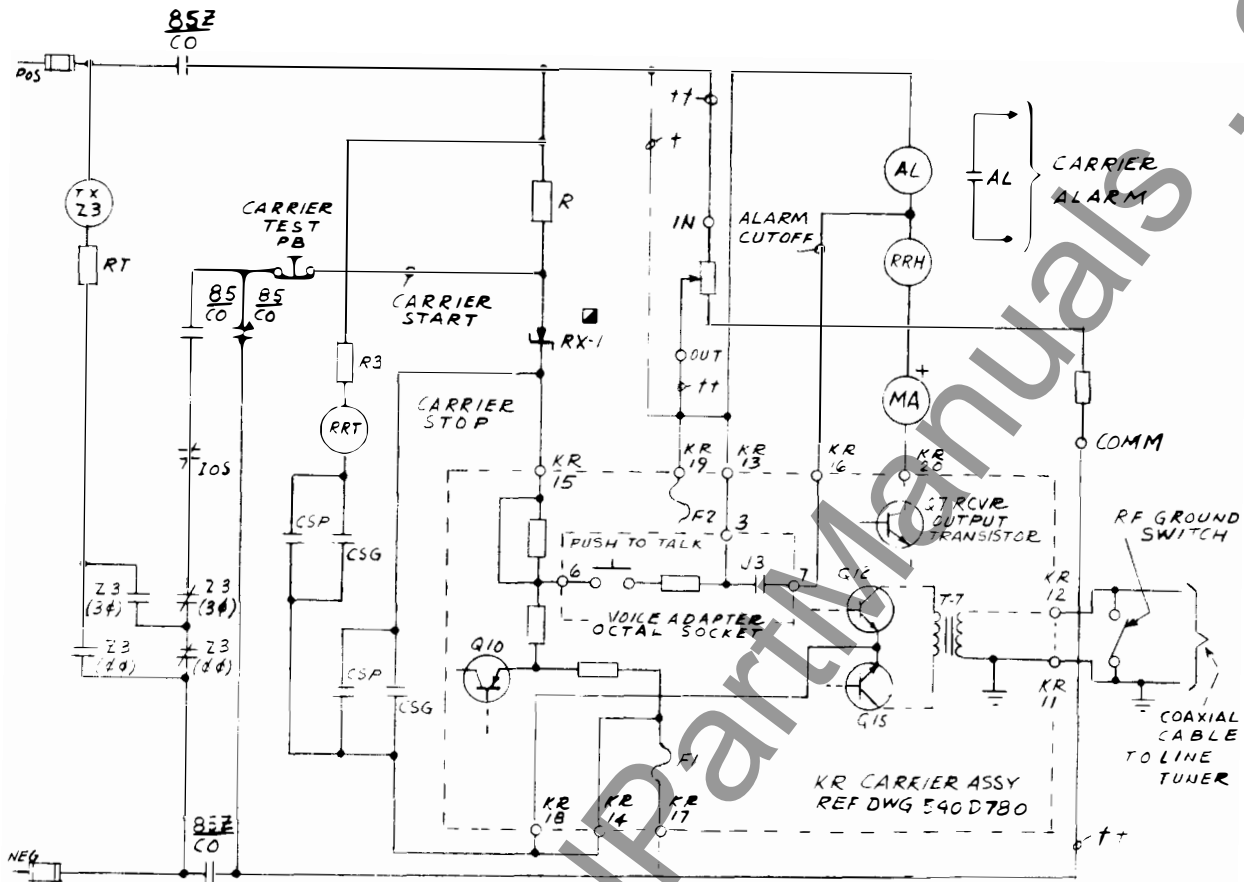

REQUIREMENTS FOR K-DAR RELAYING

SUPPLY VOLTAGE	CARRIER START	CARRIER STOP	R
51 VDC	+ 37V, 7MA	0 VOLTS	2K
129 VDC	+100V, 5MA	0 VOLTS	3.75K
258 VDC	+100V, 5MA	0 VOLTS	19K

KR RELAYING TRANSMITTER /
 RECV EXTERNAL CONNECTIONS
 TERMINAL CONNECTION

- 11 GROUND
- 2 COAXIAL CABLE
- 13 SUPERVISORY PREFERENCE CONTACT
- 14 CARRIER STOP B- RETURN
- 15 CARRIER START (POSITIVE)
- 16 ALARM CUTOFF FOR COMMUNICATIONS
- 17 E MINUS
- 18 CARRIER STOP (HZ/HZM)
- 19 B PLUS
- 20 RELAY COIL

NOTES

- * FOR R USE OHMITE VITREOUS ENAMELED DIVIDABLE ADJUSTABLE 4K OR 24K 25W RESISTOR. CONNECT & ADJUST FOR VALUES SHOWN
- ▲ TYPE IN3051 IN CARRIER ALY. RELAY
- + FOR 51 & 129 VDC SUPPLY
- ++ FOR 258VDC SUPPLY USE 330C191H01 RESISTOR UNIT REF DWG 223.B.497

* Fig. 4-Relaying Control Circuits-K-Dar (Dwg. 3-329C704)

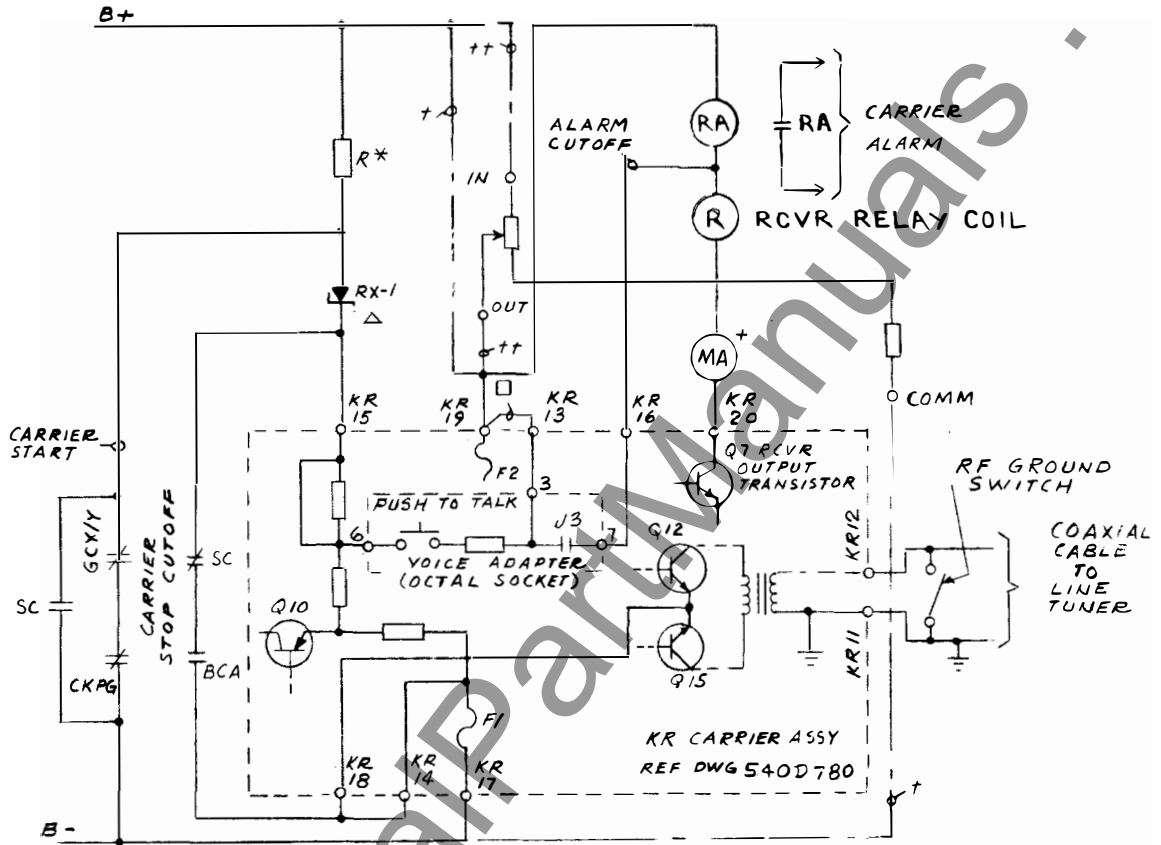

REQUIREMENTS FOR GCX/GCY RELAYING

SUPPLY VOLTAGE	CARRIER START	CARRIER STOP	R
51 VDC	+ 37V. 7MA	0 VOLTS	2K
129 VDC	+ 100V. 8MA	0 VOLTS	3.75K
258 VDC	+ 100V. 8MA	0 VOLTS	19.K

KR RELAYING TRANSMITTER /
RECV. EXTERNAL CONNECTIONS
TERMINAL-CONNECTION

- 11. GROUND
- 12. COAXIAL CABLE
- 13. SUPERVISORY PREFERENCE CONTACT
- 14. CARRIER STOP B- RETURN
- 15. CARRIER START (POSITIVE)
- 16. ALARM CUTOFF FOR COMMUNICATIONS
- 17. B MINUS
- 18. CARRIER STOP (HZ/HZM)
- 19. B PLUS
- 20. RELAY COIL

NOTES

- * FOR "R" USE OHMITE VITREOUS ENAMELED DIVIDOHM ADJUSTABLE 4K OR 20K 25W RESISTOR, CONNECT & ADJUST FOR VALUES SHOWN
- Δ TYPE IN3051
- + FOR 51 & 129 VDC SUPPLY
- ++ FOR 258VDC SUPPLY USE 330C191H01 RESISTOR UNIT REF DWG 223B497
- FOR SUPERVISORY CONTROL PREFERENCE CONTACTS

Fig. 5. Relaying Control Circuits-GCX/GCY (Dwg. 2-329C704)

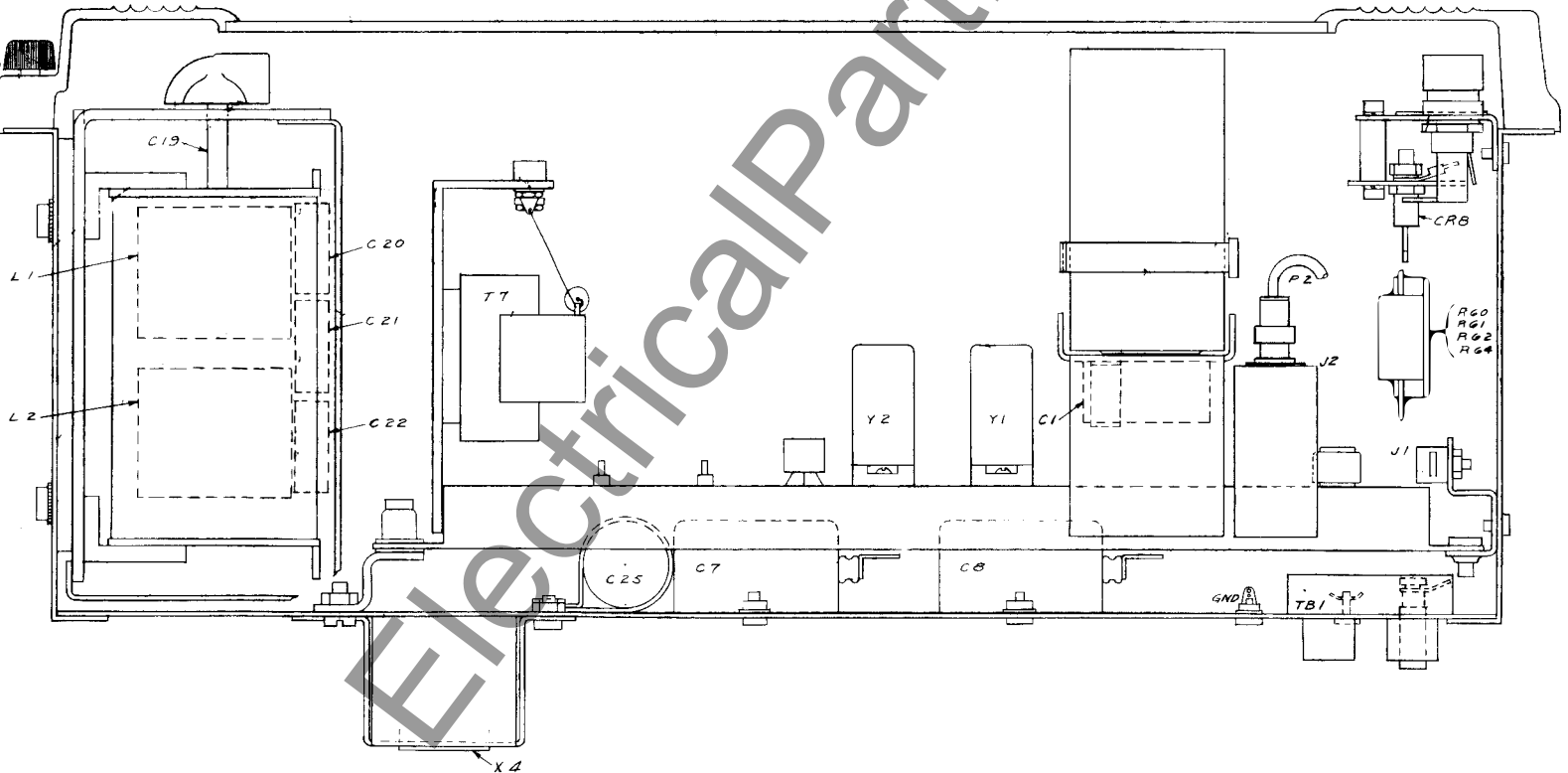
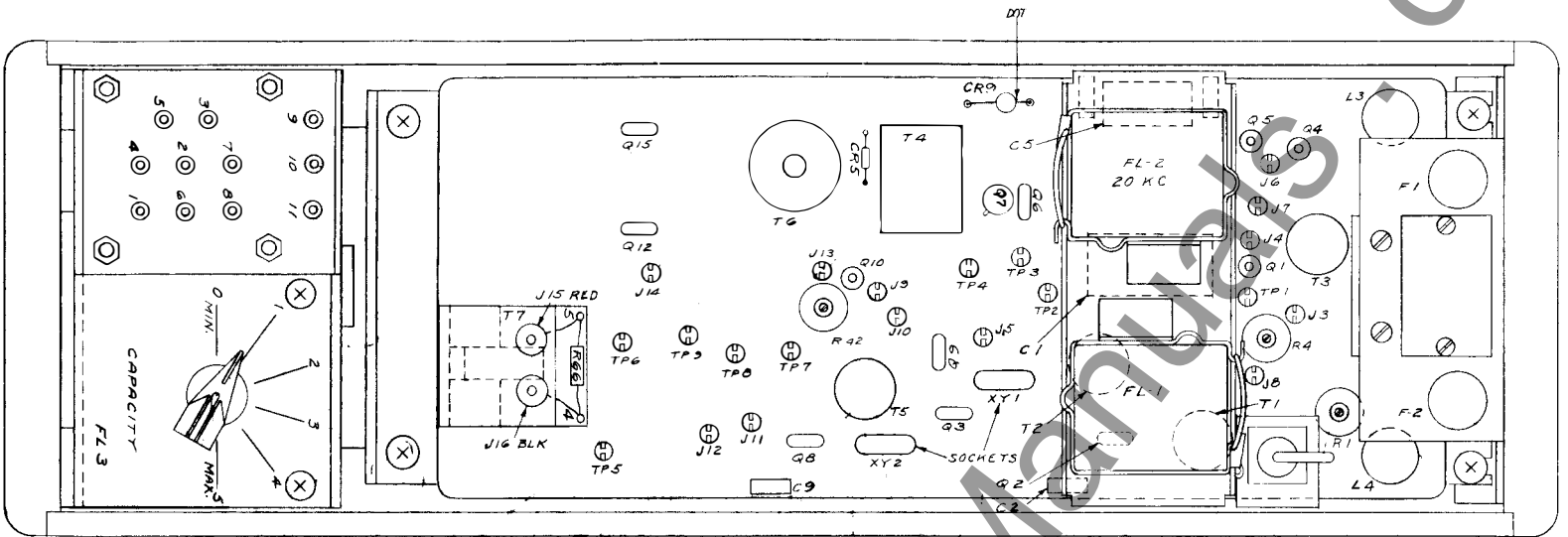
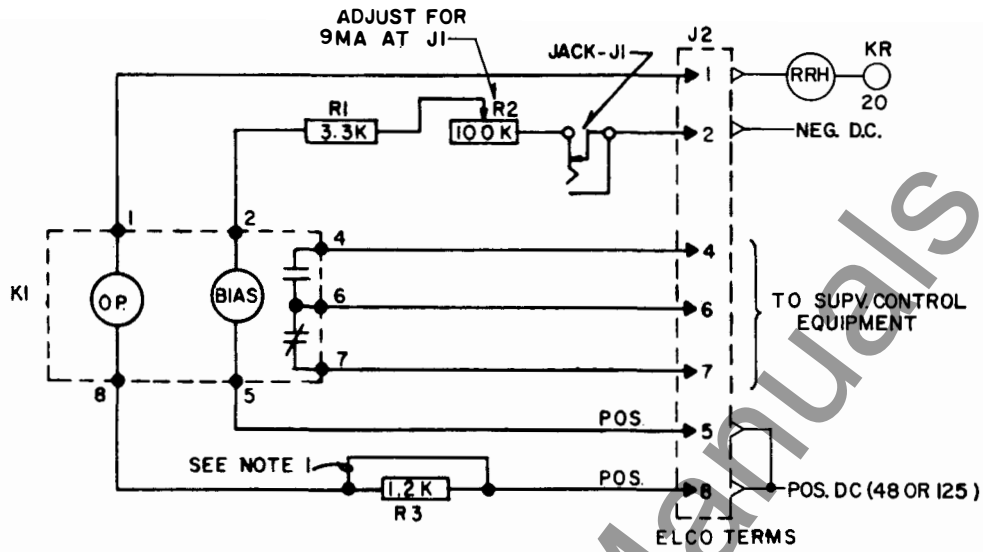
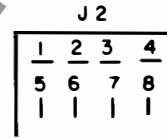

Fig. 6. Component Location (Dwg. 540D781)



NOTES:

1. REMOVE FOR KR CARRIER PLUS SUPV. CONTROL WITHOUT RELAYING.
2. POLARITY SHOWN CLOSSES CONTACT BETWEEN TERMINALS 4 & 6.



AS VIEWED FROM REAR OF PANEL

629A552

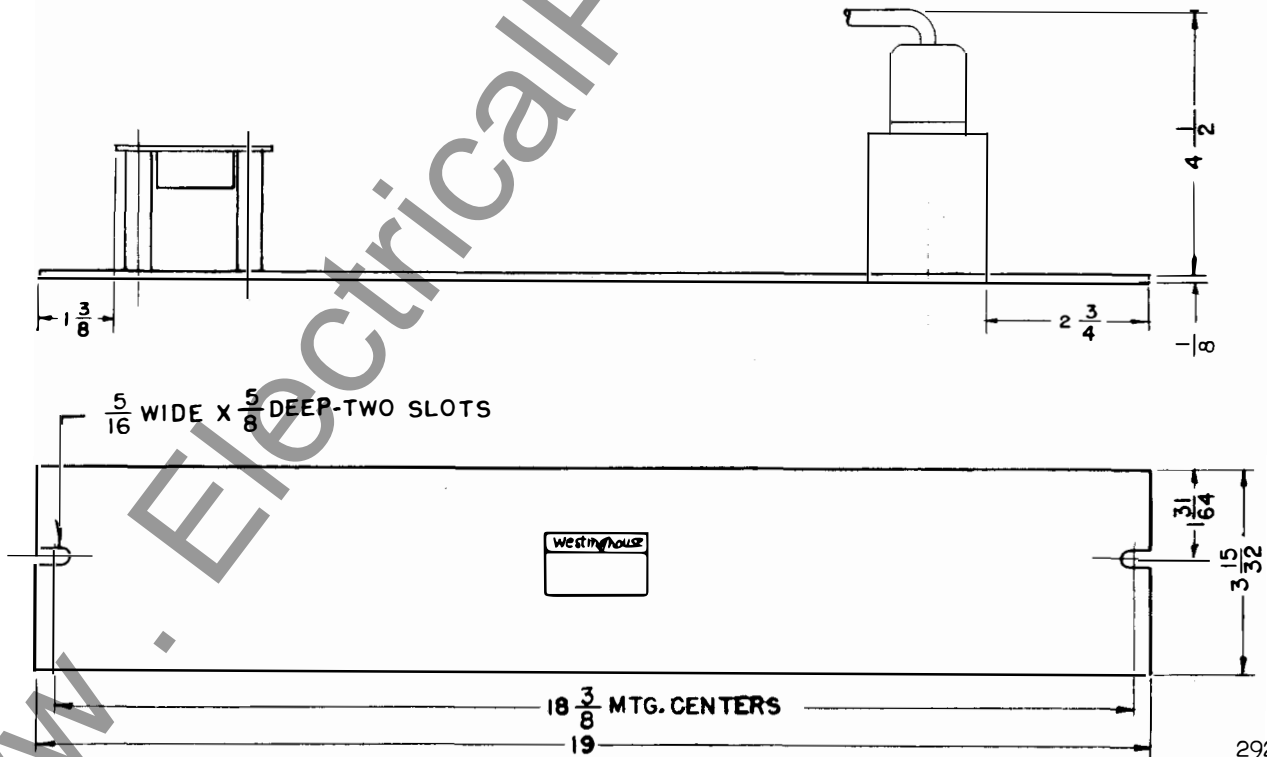

292B991

Fig. 7. Supervisory Control Auxiliary Relay Connections (Dwg. 629A552) and Outline (Dwg. 292B991).

**CONNECTIONS FOR 48-250 VOLT SERVICE AND
SUPERVISORY CONTROL APPLICATION
(CHANGES FROM JUMPERS SHOWN ON INTERNAL SCHEMATIC, FIG.2)**

250-VOLT OPERATION

FOR A 250 VOLT SUPPLY, RESISTOR UNIT 330C191M01 IS USED AS SHOWN ON APPLICATION DRAWING 329C704

FOR HZ/HZM OPERATION, THE JUMPER HAS BEEN REMOVED FROM TP-6 TO TP-7. (NOT REMOVED FOR K-DAR RELAYING).

RESISTOR UNIT SCHEMATIC:

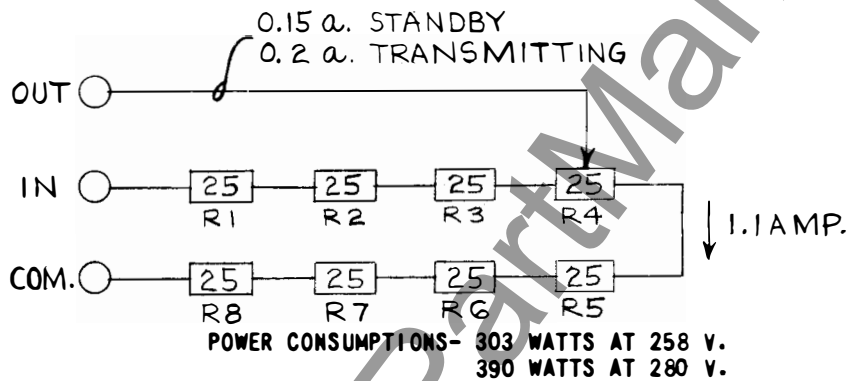

NOTE: KR SUPPLY VOLTAGE WILL BE APPROXIMATELY 144 VOLTS UNDER STANDBY CONDITION WHEN BATTERY VOLTAGE IS 280 VOLTS.

125-VOLT HZ/HZM OPERATION

JUMPER TP-7 AND TP-8 IS REMOVED.

48 VOLT OPERATION

ON PRINTED CIRCUIT BOARD ADDITIONAL JUMPERS ARE CONNECTED AS FOLLOWS:

- BETWEEN TP8 AND TP9
- BETWEEN TP5 AND J12
- BETWEEN TP1 AND TP2
- BETWEEN TP3 AND TP4

IN THE FT CASE, JUMPERS ARE CONNECTED ACROSS R60 AND R64, AND THE CONNECTION BETWEEN R64 AND DIODE CR8 IS REMOVED.

IN ADDITION, FOR 48-VOLT SUPERVISORY CONTROL, R59 IS CONNECTED INTO THE CIRCUIT.

Fig. 8. Connections, 48-250 Volts and Supervisory Control (Dwg. 407C971)

TRANSMITTER OUTPUT FILTER FL-3 CONNECTIONS

<u>LINE</u>	<u>FREQUENCY RANGE</u>	<u>COIL</u>	<u>COIL CONNECTIONS</u>	<u>PARALLEL CAPACITOR CONNECTIONS</u> Δ
1	27.7 KHZ-30.0 KHZ	L-1	(1-5) (3-6)	6-8-9-10-11
2	29.8 KHZ-33.1 KHZ	L-1	(1-5) (3-6)	6-8-10-11
3	31.8 KHZ-36.0 KHZ	L-1	(1-5) (3-6)	6-8-9-11
4	35.4 KHZ-39.0 KHZ	L-1	(1-5) (3-6)	6-8-11
5	38.0 KHZ-41.0 KHZ	L-1	(1-2) (3-6)	6-8-9-10-11
6	40.3 KHZ-45.0 KHZ	L-1	(1-2) (3-6)	6-8-10-11
7	43.0 KHZ-49.0 KHZ	L-1	(1-2) (3-6)	6-8-9-11
8	47.7 KHZ-56.0 KHZ	L-1	(1-2) (3-6)	6-8-11
9	49.5 KHZ-58.5 KHZ	L-1	(1-2) (3-6)	6-8-9-10
10	57.0 KHZ-72.3 KHZ	L-1	(1-2) (3-6)	6-8-10
11	67.0 KHZ-76.0 KHZ	L-2	(1-4) (6-7)	6-8-9-11
12	75.0 KHZ-88.0 KHZ	L-2	(1-4) (6-7)	6-8-11
13	77.5 KHZ-93.0 KHZ	L-2	(1-4) (6-7)	6-8-9-10
14	89.3 KHZ-114.5 KHZ	L-2	(1-4) (6-7)	6-8-10
15	102.7 KHZ-147.0 KHZ	L-2	(1-4) (6-7)	6-8-9
16	136.6 KHZ-210.0 KHZ	L-2	(1-4) (6-7)	6-8

Δ =CONNECTION FROM 6 TO 8 IS MADE BENEATH TERMINAL PLATE ON ALL SETS AT THE FACTORY.

* Fig. 9. Connections - Output Filter (Dwg. 149A420)

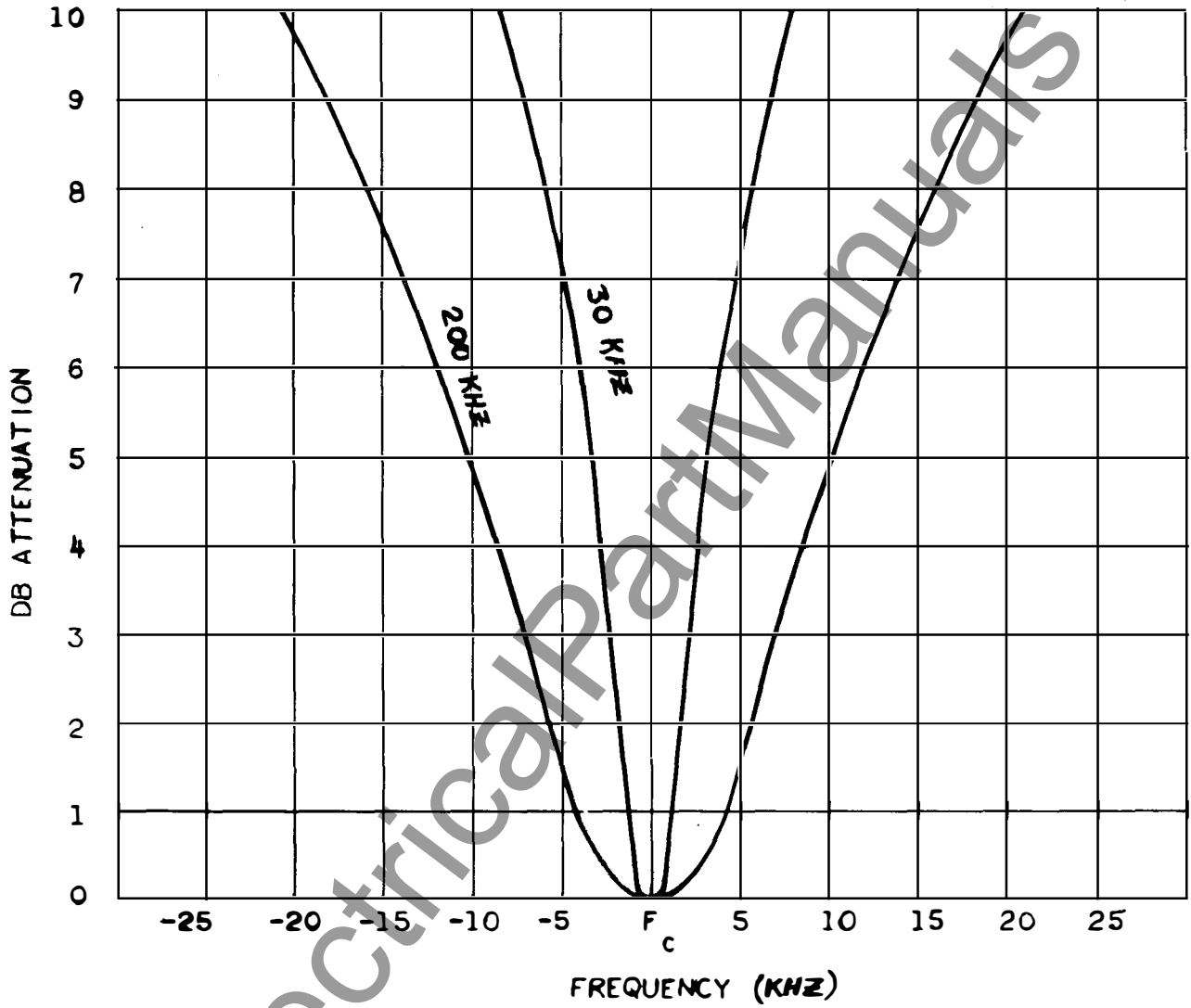

* Fig. 10. Transmitter Output Filter Selectivity (Dwg. 377996)

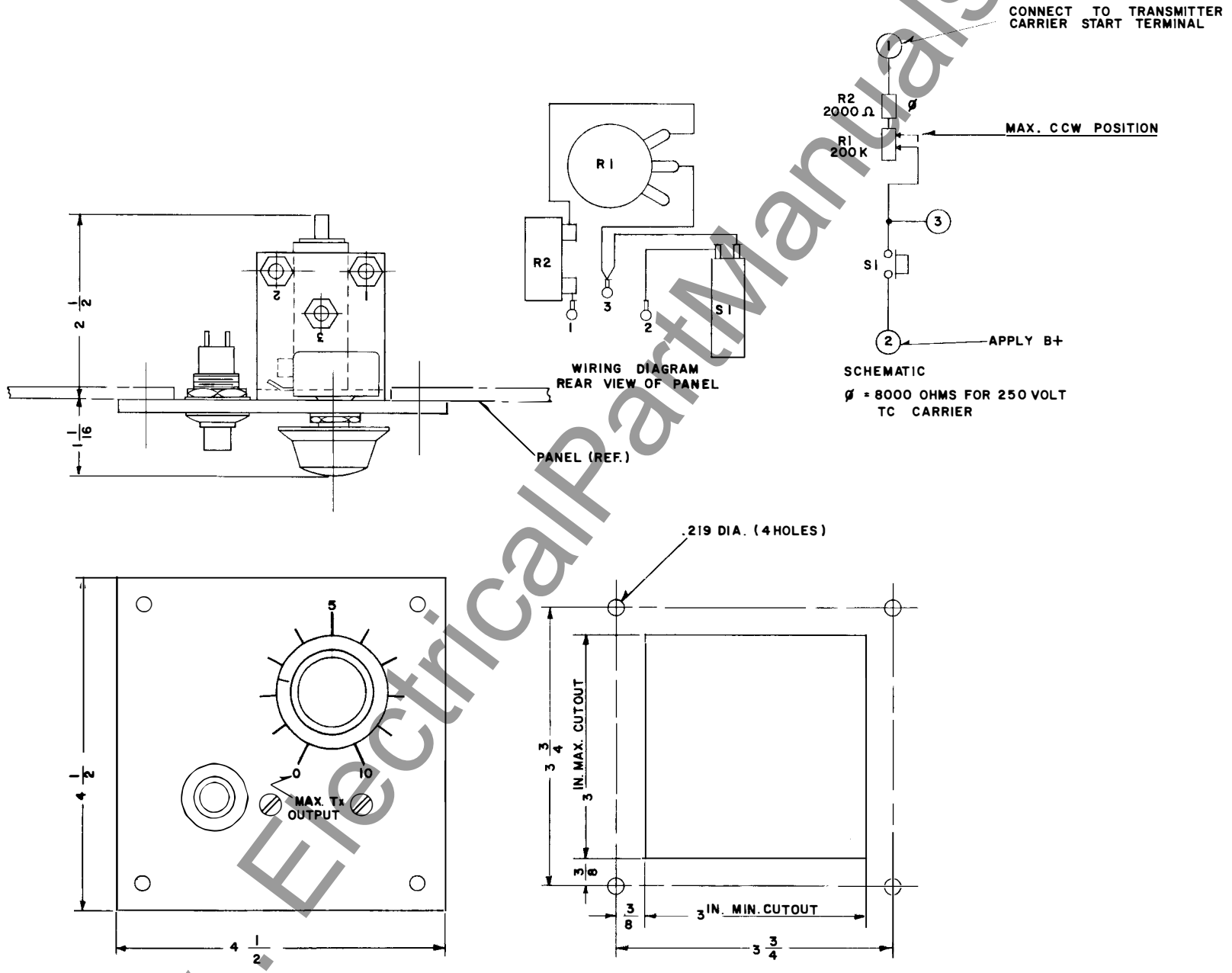

* Fig. 11. Reserve Signal Detector Outline (Dwg. 329C703)

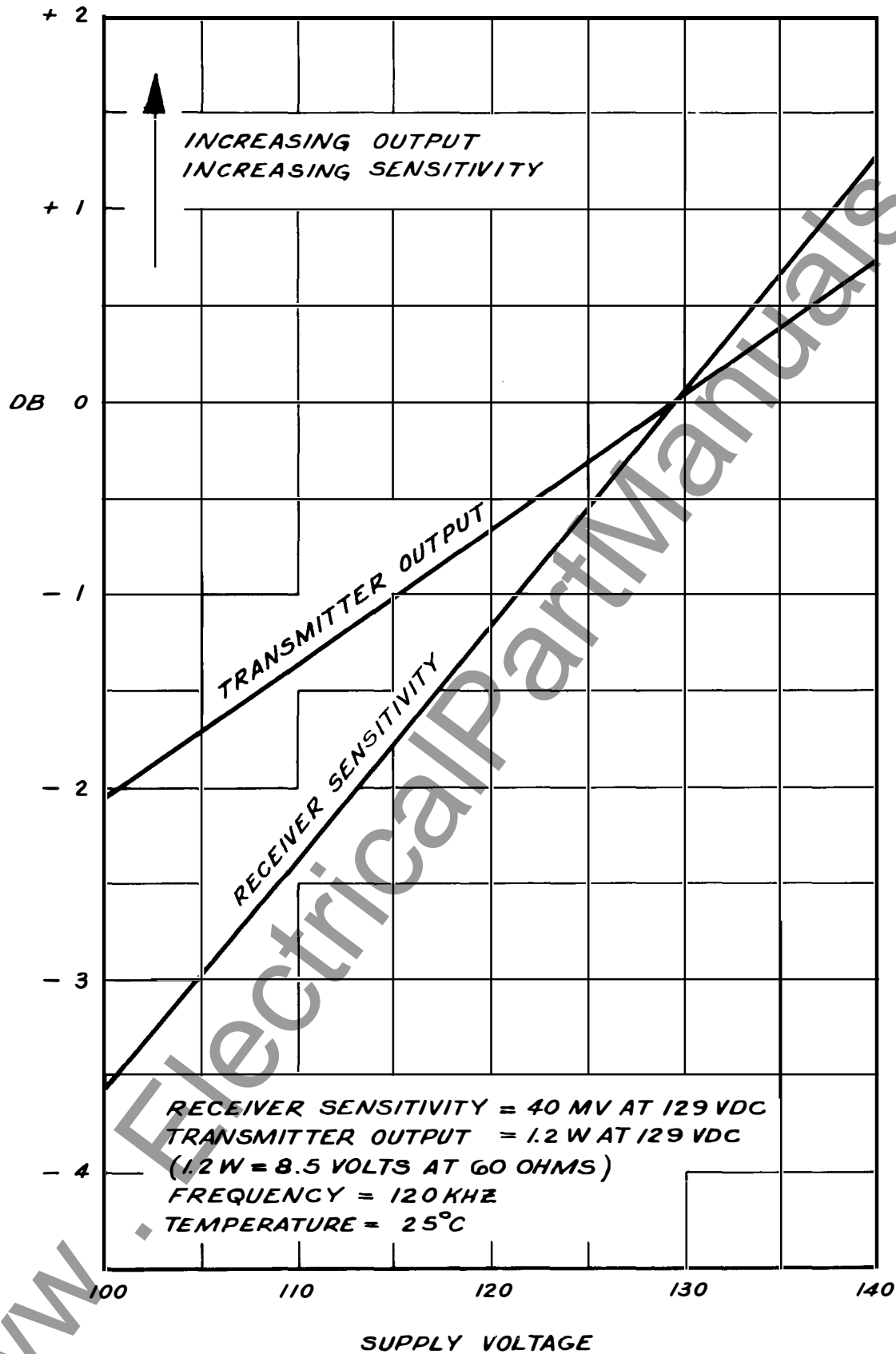

* Fig. 12. Transmitter Output and Receiver Sensitivity Variations with Voltage (Curve # 377999)

TRANSMITTER OUTPUT & RECEIVER SENSITIVITY
VARIATIONS WITH FREQUENCY

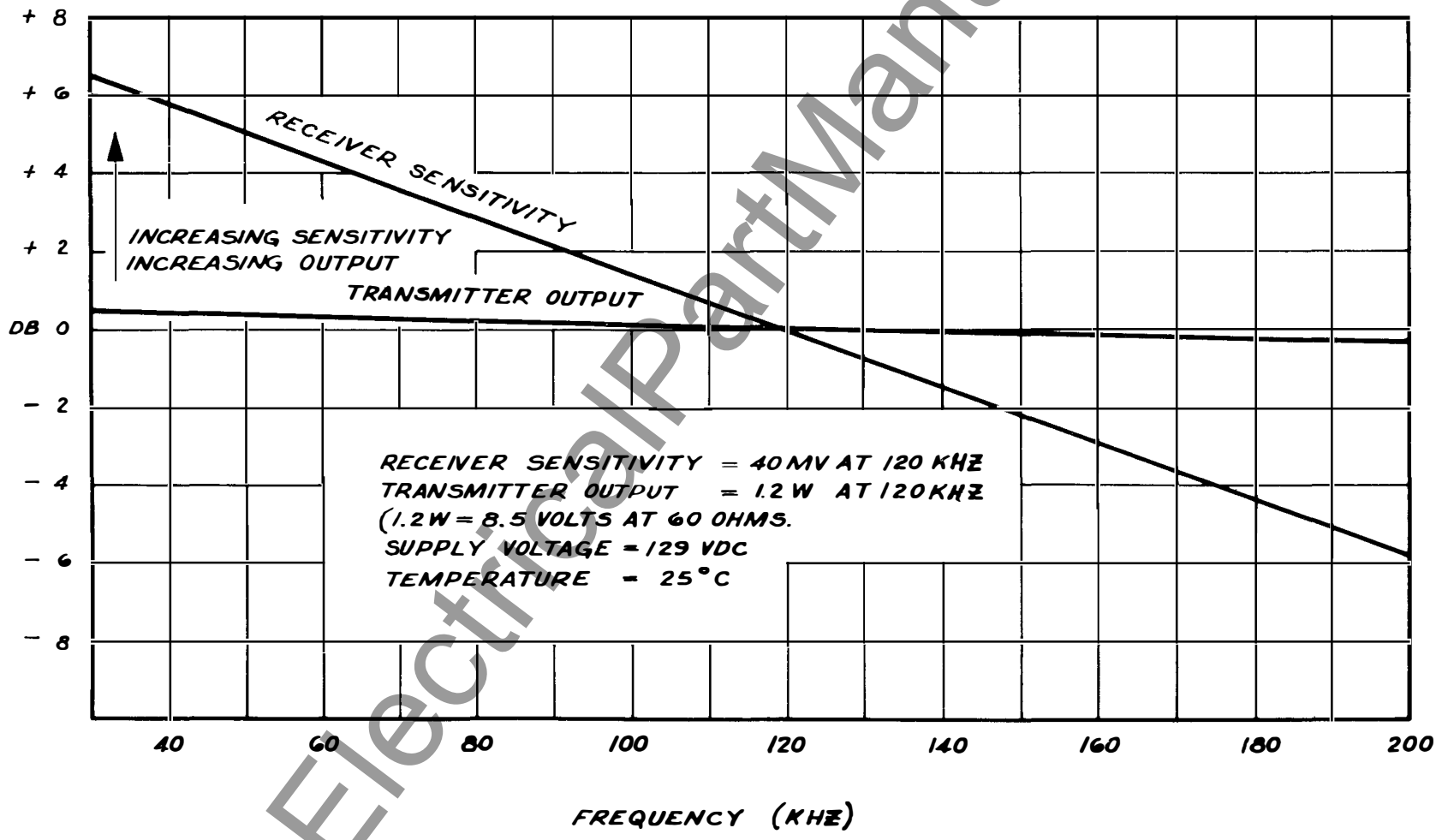

* Fig. 13. Transmitter Output and Receiver Sensitivity Variations with Frequency (Curve# 378000)

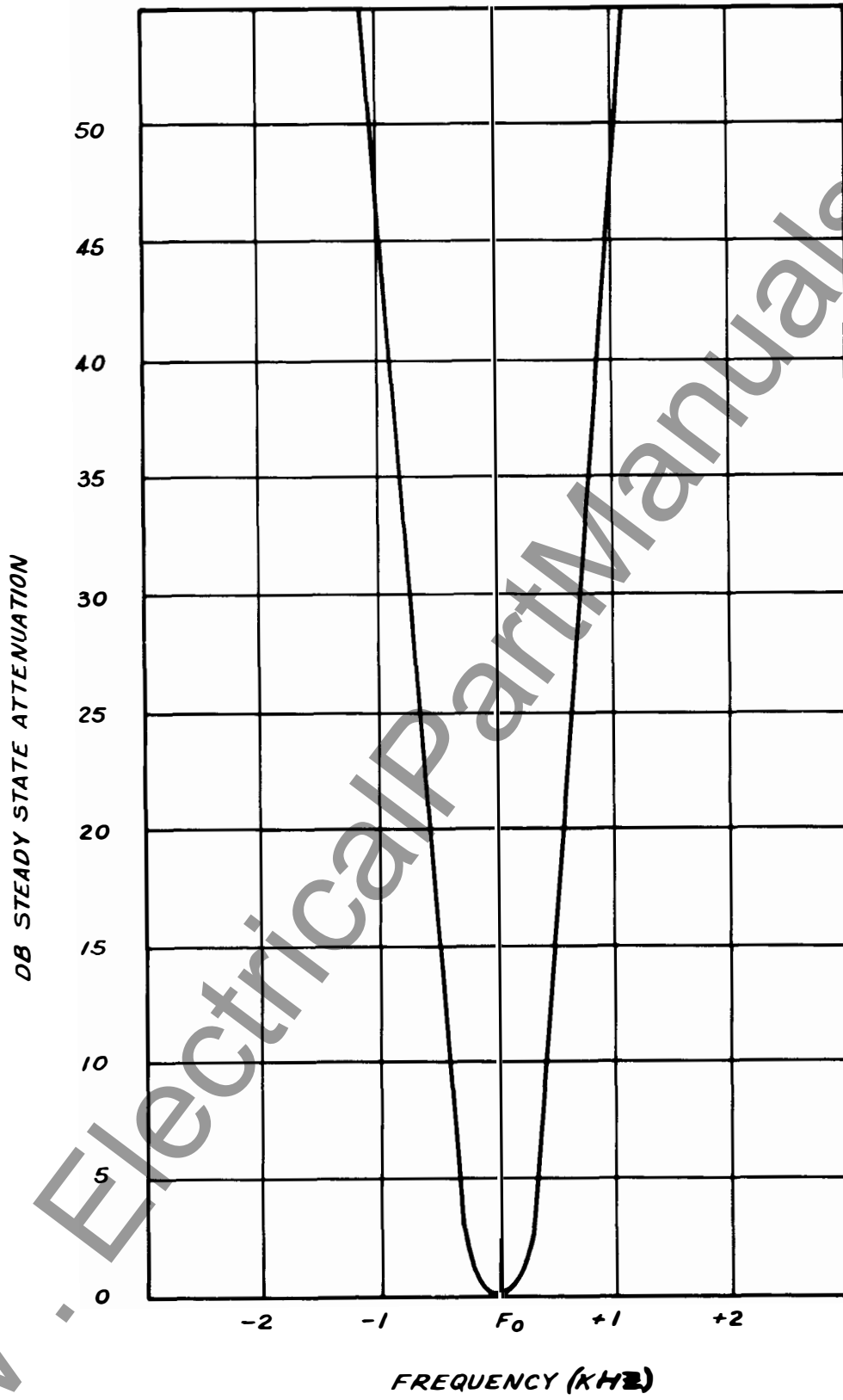

* Fig. 14. Receiver Selectivity (Curve# 377993)

IF FILTER TEST CIRCUIT

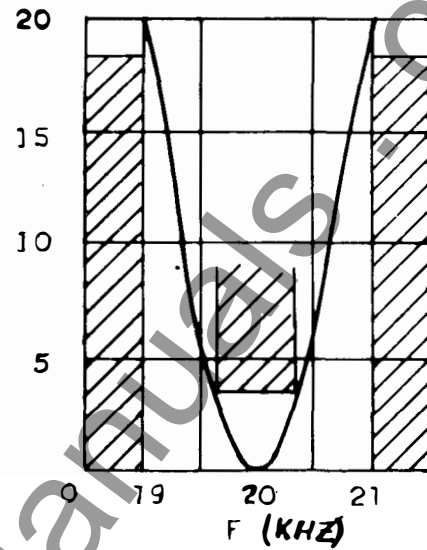
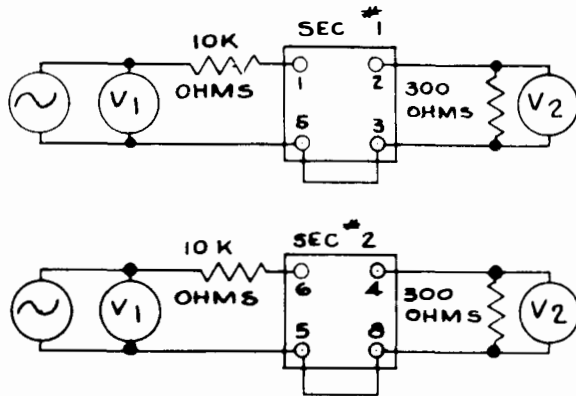

Each section of FL-2 requirement with typical selectivity curve. Insertion loss 26 DB max. Including matching resistor.

FOR BOTH CURVES

$$DB = 20 \log \frac{V_1}{V_2}$$

RF FILTER TEST CIRCUIT

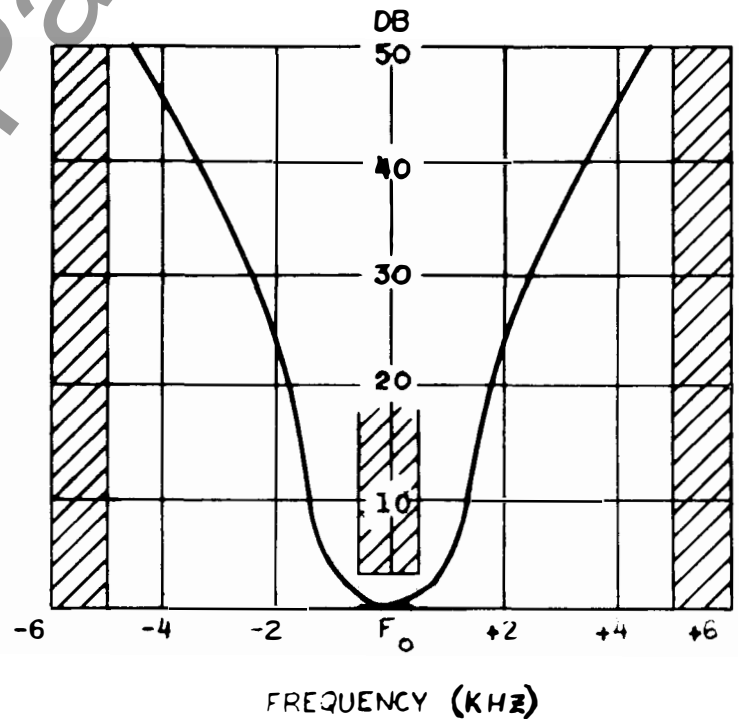
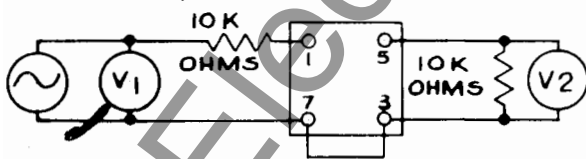

FL-1 Requirement with typical selectivity curve at 120 KHZ. Insertion loss 18 DB max. Including matching resistor.

* Fig. 15. Receiver Filter Limits (Curve# 377995)

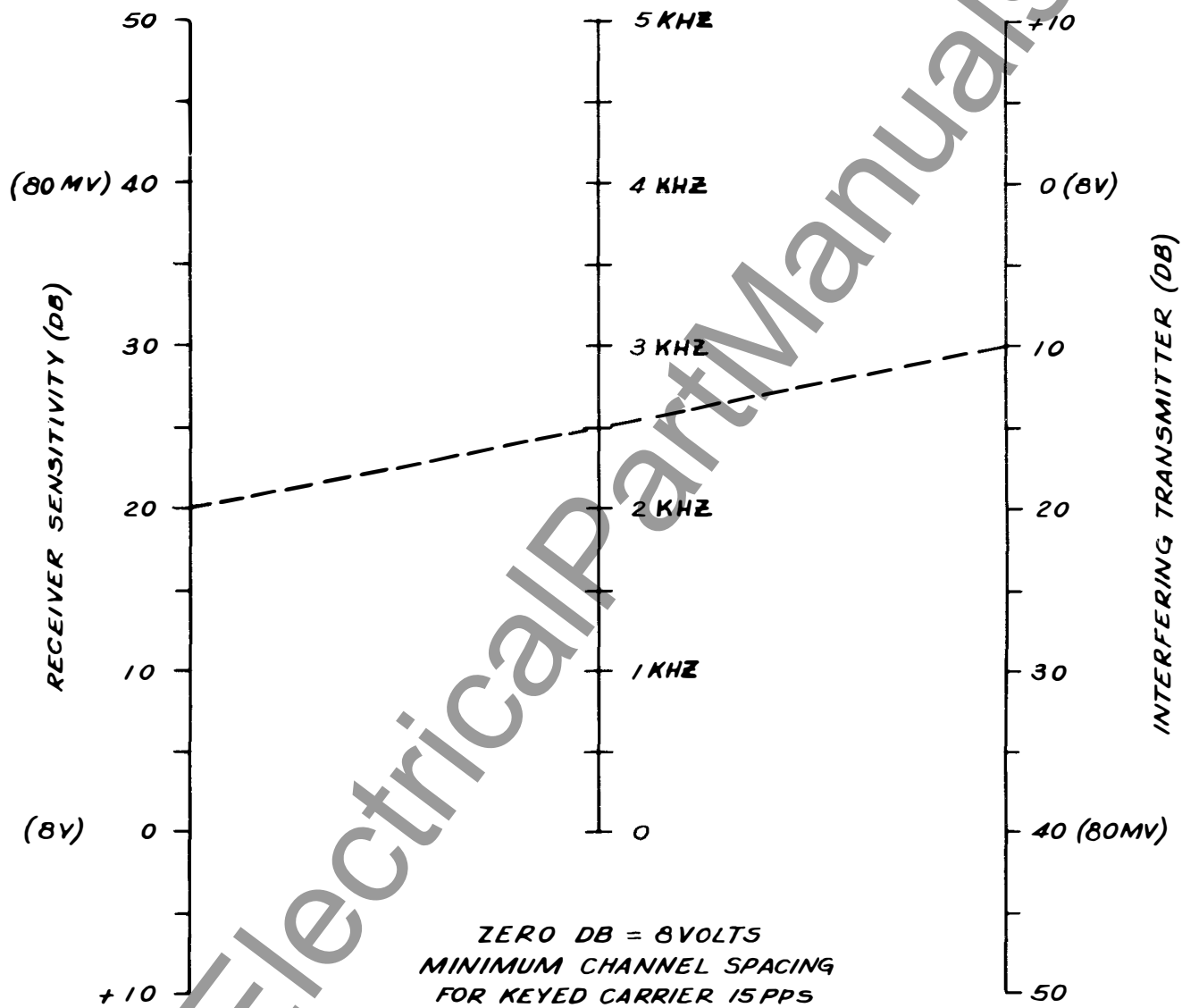

* Fig. 16. Minimum Channel Spacing (Curve* 377998)

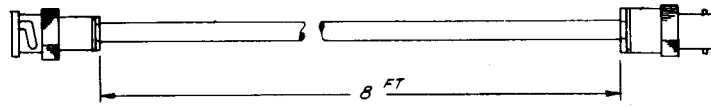

Coaxial Lead...756D346 G02

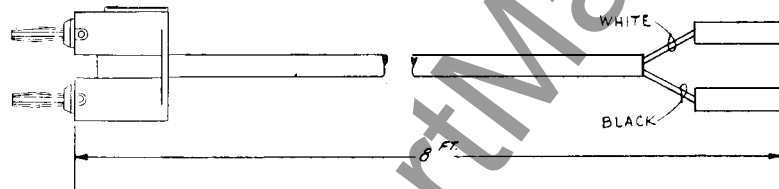

Output Lead...756D346 G03

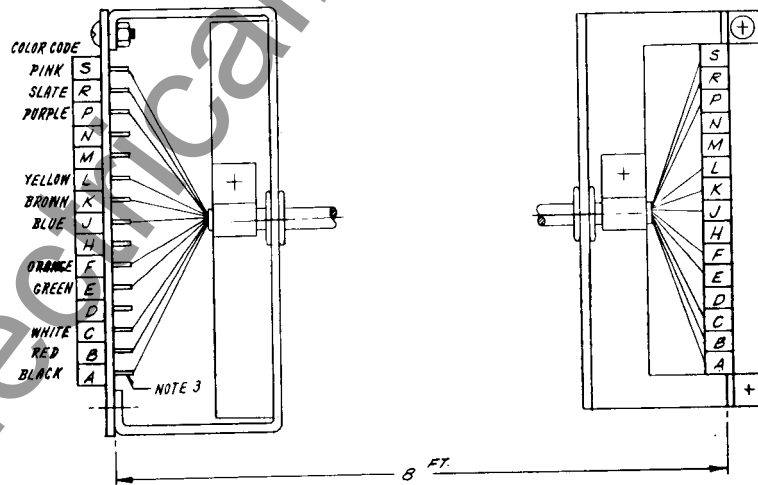

Main Harness...756D346 G04

Fig. 17. Test Harness - (Complete Set)

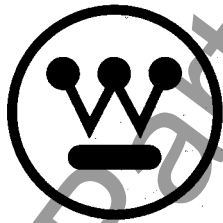

WESTINGHOUSE ELECTRIC CORPORATION
RELAY-INSTRUMENT DIVISION

NEWARK, N. J.

Printed in U.S.A.



INSTALLATION • OPERATION • MAINTENANCE I N S T R U C T I O N S

TYPE KR CARRIER RELAYING TRANSMITTER-RECEIVER

Flexitest Case Mounted —with provision for rear-mounter Voice Adapter Accessories.	Style
KR Reserve Signal Detector	470D167 G02
250 Volt Resistor Unit	330C191 H01
Test Harness (Complete Set)	756D346 G01
Coaxial Lead	756D346 G02
Output Lead	756D346 G03
Main Harness	756D346 G04

TABLE OF CONTENTS

Introduction	Page 2
Specifications	Page 2
Description	
General	Page 3
Mechanical	Page 3
Electrical	
Transmitter	Page 4
Receiver	Page 4
Transmitter Control Circuits	Page 5
Reserve Signal Detector	Page 5
Communications	Page 5
Relaying Control Circuits	Page 5
Installation	
General	Page 6
Connections	
External	Page 6
Internal	Page 7

Adjustments

Transmitter	Page 7
Receiver	Page 7
Reserve Signal Detector	Page 8
250-Volt Resistor Unit	Page 8
Frequency Change	Page 8
Maintenance	Page 9
Application	Page 13
Electrical Parts List	Page 14

LIST OF TABLES

Table

1 D-C Pin Jack Measurements with Reference to B-	Page 10
2 Transistor DC Measurements with Reference to B-	Page 11
3 D-C Bleeder Measurements with Reference to B-	Page 12
4 Typical RF Signal Measurements for Receiver	Page 12
5 Typical RF Signal Measurements for Transmitter	Page 13

LIST OF ILLUSTRATIONS

Figure		References
1	Outline – Flexitest Case	540D753
2	Internal Schematic	540D780
3	Relaying Control Circuits (HZ/HZM)	1-329C704
4	Relaying Control Circuits (K-Dar)	3-329C704
5	Relaying Control Circuits (GCX/GCY).....	2-329C704
6	Component Location.....	540D781
7	Supervisory Control Receiver Connection.....	223B498
8	Connections, 48-250 volts and Supervisory Control.....	407C971
9	Transmitter Output Filter Connections	149A420
10	Transmitter Output Filter Selectivity.....	C377996
11	Reserve Signal Detector – Outline and Schematic	329C703
12	Transmitter Output and Receiver Sensitivity Variations with D-C Voltage	C377999
13	Transmitter Output and Receiver Sensitivity Variations with Frequency.	C378000
14	Receiver Selectivity	C377993

15	Receiver Filter Limits	C377995
16	Minimum, Channel Spacing	C377998
17	Test Harness	756D346

CAUTION The voltages encountered in this equipment are dangerous to life. To be safe, disconnect the power source and close the grounding switch when servicing the equipment.

INTRODUCTION

The Type KR Relaying Transmitter-Receiver is designed for Distance Relaying, Telemetry, Supervisory Control and Sleet Detection. Facilities are provided for a plug-in type voice adapter. The basic design is for operation from 125-volt station batteries. However, the apparatus may also be operated from 48-volt or 250-volt station batteries by means of various internal connections. These various connections as well as most of the adjustments are made at the factory, although they can be changed in the field.

Although designed primarily for operation with Westinghouse protective relays, this apparatus may also be coordinated with other types of directional-distance relays and with most other contact keyed devices.

SPECIFICATIONS

Frequency Range.....	30-kHz to 200kHz *
Channel Attenuation Rating	40-db
Transmitter Power Output.....	1.0 watt at standard conditions (see Figs. 12 and 13). 0.5 watt with a 48-volt d-c supply.
Transmitter Harmonic Output	At least 46-db below fundamental.
Transmitter Output Impedance.....	Matches one 60-ohm coax. cable. (Suitable for 50-70 ohm cable.)
Transmitter Output Filter Selectivity	See Fig. 10
Transmitter and Receiver Oscillator and Frequency Stability	From -20° C to +50° C with simultaneous voltage variations from 100 to 140 VDC, the frequency remains with 0.01%.

Permissible Battery Voltage Ripple	7-1.25%
Ambient Temperature Range	-20°C to +50°C.
Non-Operating Temperature Range	-40°C to +70°C
Receiver Sensitivity	0.04 volts at standard conditions (see Figs. 10 and 18).
Receiver Selectivity	See Fig. 14
Receiver Signal-to-Noise Ratio Requirements	12 db
Minimum Channel Spacing	See Fig. 16
Power Input	115-ma at 48 VDC, 200-ma at 125 VDC, 1.28 amperes at 250 VDC.
Carrier On-Off Keying	Requires one pair of contacts capable of keying 8-ma DC at an open circuit voltage of 125 VDC.
Weight (With Flexitest Case)	Approximately 16-lbs.

CAUTION Refer application to Westinghouse when other transmitters are to be connected to the same coax cable as certain conditions may result in damage to the output transistors.

NOTE Standard conditions are taken as 129-volts,
* 120-kHz and 25°C.

DESCRIPTION

General

This completely transistorized carrier-apparatus is a result of extensive field and laboratory tests. From these tests, it was proven that transistors provide superior reliability over tubes. In addition, the latest printed circuit and filter techniques have improved performance and greatly decreased the size. The expected long life of transistors as compared with vacuum tubes will reduce maintenance costs, and the low power requirements will produce important savings in battery and charger requirements.

Transistors perform the same functions as vacuum tubes. However, tubes operate by the flow of electrons in a vacuum between elements, while transistors depend upon the movement of electrons in a solid. This leads to a more rugged type of construction. Most transistors are made from either germanium

or silicon semi-conductor materials. The junction transistor consists of a thin slice of germanium or silicon with three different regions produced by introducing specific amounts of impurities. A thin wire is connected to each region. One outer region is called the emitter, the other the collector, and inserted between them is the base. These correspond roughly to the cathode, plate, and grid of a vacuum tube.

The transistors in this equipment are of the junction type, and both NPN and PNP configurations are used. In the NPN transistor, the majority of the current is carried by electrons. In the PNP transistor there is a deficiency of electrons. These deficiencies are known as "holes". For practical purposes holes may be considered as positively charged "electrons", and these provide most of the current flow in PNP units. In order to obtain maximum efficiency and reliability, both types are used in this equipment.

Silicon transistors are used in the transmitter and receiver output circuit in order to stabilize critical circuit performance at elevated temperatures.

Mechanical

This apparatus is supplied in a Flexitest case and may be either flush or projection mounted in

order to match other switchboard equipment. The outline dimensions and also the drilling plan for flush and projection mounting are shown by Fig. 1. The majority of the parts are mounted on a printed circuit board. This board may be readily removed as follows:

1. Remove the two output plugs from the red and black jacks.
2. Disconnect the receiver input coaxial cable connector.
3. Loosen the two screws at the top of the board.
4. Loosen the two screws at the bottom of the board and pull them out as far as they will extend.
5. Pull board down to disengage the terminals and lift out.

The transmitter output filter may be removed by removing four mounting screws from the bottom of the case and disconnecting the coaxial cable.

Fig. 6. shows the location of major components such as potentiometers, jack, test points, crystals, transistors, etc. External connections and the Schematic Diagram are shown by Fig. 2. The numbered terminals shown as squares apply to the external terminals.

Provisions are made for plugging the Voice Adapter Unit in the rear of the relaying equipment. Octal socket marked X-4 on the rear of the set accommodates the adapter plug. A buckle type strap on each side of the adapter holds the unit in place after it has been plugged in. The normal projection for a rear mounted Voice Adapter is 3-inches beyond that of the relaying equipment. When the KR Relaying Unit is supplied with the adapter, a patch cord is available on separate order. This patch cord plugs into the telephone jacks on the adapter and provides an extension to a conveniently located terminal board.

The panel cutout information necessary for mounting the Reserve Signal Detector is shown by Fig. 11.
 * This unit consists of a potentiometer and pushbutton switch mounted on a small panel, itself suitable for switchboard mounting.

For 250-volt operation, separate auxiliary resistors are required, as shown in Fig. 8.

Electrical

Transmitter

The transmitter is made of four main stages in-

cluding an oscillator, driver, power amplifier, and an output filter. In the oscillator, the crystal is operated as a resonant circuit between the collector of one transistor and the base of the other. The feedback is supplied through a capacitor from the collector of the second transistor to the base of the first transistor. The frequency is independent of voltage or temperature changes of the transistors. Thus the frequency stability is the stability of the crystal.

The input to the driver stage Q-10 is controlled by potentiometer, R-42 which also controls the transmitter power output. In HZM relaying CARRIER STOP provides about +40 volts for blocking. This is applied to Q-10 through T-6. Diode CR-5 prevents damage to the transistor when this positive voltage is applied to the collector. For CARRIER START (when in the blocked position) a small positive voltage is applied to the collector of Q-10 by means of bleeder resistors R-67 and R-68.

The power amplifier consists of two transistors Q-12 and Q-15, which are operated as class B amplifiers in push-pull. Resistors R-52 and R-55 are for stabilization.

The output transformer, T-7, matches coaxial cables of 50 to 70 ohms.

Resistor R-66 tends to keep the source impedance constant to permit proper tuning of the output filter.

The output filter consists of coils L-1 and L-2, capacitors C-19 through C-22. The filter is tunable, and is provided to attenuate harmonics and other spurious outputs. It should be noted that the filter contains no shunt elements, resulting in a reverse impedance free of "across the line" resonances.

Receiver

The receiver is a superheterodyne in order to obtain constant selectivity regardless of the channel frequency. (See Fig. 14.) The major stages include an input filter, attenuator, oscillator, mixer, IF filters, IF amplifiers, detector and a D-C power output stage.

The input filter prevents undesired signals from producing the IF frequency.

The receiver sensitivity is adjusted by means of the continuously variable input control R-1 and by

connecting or disconnecting resistors R-73 and R-74 in the IF stages.

The receiver oscillator (Q-2 and Q-3) is basically the same as the transmitter oscillator. The * frequency is 20-kHz above the incoming signal frequency.

The receiver channel frequency is determined by the input filter and the oscillator crystal. The frequency may be changed readily since both the filter and the crystal are plug-in components.

Mixing is accomplished by feeding the incoming signal to the emitter and the receiver oscillator signal to the base of the mixer Q-1. Mixer oscillator requirements are met through adjustment of potentiometer R-4. Injection into two separate elements, base and emitter, provides a circuit capable of handling greater signal level variations than one in which injection is made into only a single element such as the base.

This receiver uses an IF frequency of 20-kHz. The overall selectivity is determined primarily by the * IF filter FL-2. Typical characteristics of this filter are shown in Fig. 15.

The IF amplifier consists of transistors Q-4, Q-5 and Q-6.

The detector is a full wave bridge rectifier. This rectifier in conjunction with the IF amplifier Q-6, provides the necessary power to drive the D-C power output stage Q-7.

The final output stage Q-7 will supply approximately 18 milliamperes to a standard 1700 ohm distance relay RRH coil and its associated 500 ohm alarm coil. It may also be used to drive other relay coils such as is shown by Fig. 7, Supervisory Control Connections.

Transmitter Control Circuits

In the standby condition, although the oscillator is running, the transmitter driver has no emitter bias which results in no output.

Positive voltage applied to terminal 15 supplies this bias through a voltage dividing network, and transmitter output results. The actual configuration of the network is a function of supply voltage and application (Relaying, Telemetry, etc.) and is

discussed in the Adjustments section.

Output may be stopped in several ways. The method used with K-DAR relays is to remove the positive voltage applied to terminal 15. In the case of distance relaying with Westinghouse HZ/HZM relays, application of a positive voltage to terminal 18 will stop the transmitter output. Output may also be stopped by removal of negative battery from terminal 18.

Reserve Signal Detector

The Reserve Signal Detector is shown by Fig. 11. Effectively R-1 is a remote transmitter output control. This control is obtained through varying the driver Stage (Q-10) emitter bias, and is effective over a 25-db range of transmitter output. The detector is switched into service by S 1. By adjusting R-1 for a given receiver relay current at the far end of the channel, a relative measure of the channel attenuation may be obtained. This is discussed further in the section on Adjustments.

Communications

The transmitter output is reduced approximately 6-db when the Type KR voice adapter attachment is used. Relaying takes preference, and full output is obtained since full voltage is supplied to terminal 15.

Relaying Control Circuits

Figs. 3, 4 and 5 show simplified diagrams of the relaying control circuits.

1. K-DAR and GCY Relaying (Figs. 4 and 5)

The control of the carrier set is obtained through the CARRIER START and CARRIER STOP contacts. These contacts are shown in their normal standby condition.

The K-DAR or GCY relays operating from the voltage and current on the transmission line, detect and determine the direction of a line fault and thereby control the carrier transmitter and receiver.

The control of the carrier set is such as to start the transmission of carrier when fault power on the transmission line is flowing out of the line section being protected. Conversely, when fault power is flowing into this line section, the control is such as to block the transmitter and keep it from being turned * on by secondary functions such as reserve signal de-

TYPE KR CARRIER SET

tection and communication, should these functions be in use at the same time. Should carrier be received from the remote station, the hold coil and alarm coil will energize through transistor Q-7 in the receiver.

When carrier start operation occurs, the CARRIER START contact opens applying a positive voltage (see Figs. 4 and 5) to terminal 15 of the carrier set. This puts a potential on the driver stage in the transmitter and also applies proper bias for the power amplifier.

When a carrier stop operation occurs, the CARRIER STOP contact closes, which removes B+ (terminal 15) from the driver and the power amplifier stages in the transmitter. CARRIER STOP, terminal 18, on the carrier set is permanently connected to terminal 14, for K-DAR and GCY relaying.

2. HZM Relaying (Fig. 3)

The control of the carrier set is effected by the CARRIER START and the CARRIER STOP contacts. These contacts are shown in their normal standby condition.

The HZ-HZM relays operating from the voltage and current on the transmission line, detect and determine the direction of a line fault and thereby control the carrier transmitter and receiver.

* The control of the carrier set is such as to start the transmission of carrier when fault power on the transmission line is flowing out of the line section being protected. Conversely, when fault power is flowing into this line section, the control is such as to block the transmitter and keep it from being turned on by secondary functions such as reserve signal detection and communication, should these functions be in use at the same time. Should carrier now be received from the remote station, the hold coil and alarm coil will energize through transistor Q-7 in the receiver.

When carrier start operation occurs, the CARRIER START contact closes applying the full battery supply voltage to terminal 15 of the carrier set. This puts a potential on the driver stage in the transmitter and also applies proper bias for the power amplifier.

When a carrier stop operation occurs, the CARRIER STOP contact opens. This applies a positive voltage (see Fig. 3) to terminal 18 which blocks the driver stage and the power amplifier stage

It is possible under certain conditions that the signals from two transmitters, attempting to block a third receiver, would be of such amplitude, phase and frequency as to cause the RRH coil current to "pulsate". It would then be possible to have a false trip.

In the case of the KR set for relaying 3-terminal lines, the transmitter frequencies (to avoid this possibility of false trip) should be separated by 100 Hz. All receivers and one transmitter would be * for the desired center frequency. One of the other transmitters would be 100 Hz above, the other 100 Hz below this center frequency.

INSTALLATION

General

Upon receipt of a unit, whether shipped separately or in an assembly, an immediate inspection should be made. Carefully check for damage or shortages.

For necessary clearances and mounting dimensions, see the following illustrations:

Flexitest Case Mounting..... Fig. 1

* Reserve Signal Detector Fig. 11

Connections

External

The external connections will vary slightly depending on the application, but in general will be along the lines described as follows: (Refer to the Schematic Diagram, Fig. 2.)

Terminals	11.....	Ground
	12.....	Coaxial Cable
	13 and 19	Supervisory Preference Contacts
	14.....	B- "CARRIER STOP" return
	15.....	Battery positive through carrier start contacts
	16.....	Battery positive for alarm cutoff (used with communication)
	17.....	B-
	18.....	Carrier Stop for HZM Relaying
	19.....	B+
	20.....	Relay Coil

CAUTION If the transmitter output load is removed while the transmitter is energized, the transistors in

the power amplifier will be permanently damaged. A dummy load should be connected to the transmitter output if the coax is disconnected and the transmitter is to be energized.

When tuning line coupling equipment, short the coaxial cable to ground before changing taps on the Line Tuner or matching transformer.

Internal

Necessary internal connections are generally made at the factory, to customer order, before apparatus shipment. For reference purposes, these are outlined in the following tabulation. Check the proper bleeder resistors before applying voltage to the equipment.

OPERATION	BLEEDER RESISTORS IN THE CIRCUIT
48-Volt K-DAR, HZM, and GCY Relaying, Telemetering, and Supervisory	R-47 and R-48
125-Volt K-DAR and GCY Relaying	R-45, R-47 and R-48
125-Volt HZM Relaying, Telemetering, and Supervisory	R-41, R-45, R-47 and R-48
250-Volt K-DAR and GCY Relaying	R-45, R-47 and R-48
250-Volt HZM Relaying, Telemetering, and Supervisory	R-39, R-40, R-41, R-45, R-47 and R-48

Various combinations of the inductors and capacitors of the transmitter output filter are required depending on the channel frequency. These are tabulated in Fig. 9.

Adjustments

This apparatus is generally tuned to and tested at the specified channel frequency before shipment. Final adjustments must be made in the field and are described in the following paragraphs. Fig. 6 shows the locations of the various controls.

Transmitter

1. Disconnect the coaxial cable and replace with a 50, 60, or 70 ohm non-inductive resistor depending on the characteristic impedance of the cable used.

2. Fig. 9 shows typical output filter connections for various frequency ranges. In some cases it may be necessary to use either a higher or lower range to tune the filter to resonance.

3. Insert fuses F-1 and F-2 to apply power to the apparatus.

4. Connect an A-C Vacuum Tube Voltmeter (VTVM) across the non-inductive load.

5. Unblock the transmitter by closing the CARRIER TEST SWITCH. An alternative is to jumper battery positive to terminal 15.

6. Beginning with the output control R-42 at the maximum counterclockwise position, advance it clockwise until a reading appears on the VTVM. Tune capacitor C-19 for a maximum voltmeter reading.

7. While increasing R-42, tune the output filter for maximum output until the output across the resistor is approximately 8 volts. (See Figs. 12 and 13.) (Approximately 5.5-volts when operating from 51-volt station battery.)

8. Open the test switch and reconnect the coaxial cable.

Receiver

1. The oscillator output control R-4 is pre-set at the factory. However, should any of the oscillator components be changed (including the transistors and the crystal) R-4 will require adjustment.

- a. Connect an A-C VTVM to jacks J-3 and J-4.
- b. Adjust R-4 for a 0.3 volt reading on the meter.

2. The unit is shipped to have a gain of approxi-

mately 250 millivolts (to produce 10 ma relay current) with input control R-1 in maximum clockwise position. About 10-db additional gain or 80 millivolt sensitivity can be obtained by clipping out resistor R-74, which is connected to the base of Q-4 and the B+ supply for the IF. Approximately 10-db gain or 25 millivolt sensitivity can be obtained by clipping out resistor R-73, which is connected to the base of Q-5 and the B+ supply for the IF. Resistor R-71 has been selected at the factory to provide an overall gain of approximately 25 millivolts.

a. Sensitivity Adjustment for Noise

If the maximum on-frequency noise level is known or can be measured, the receiver can be adjusted for this level. Disconnect the coaxial cable and connect a 60-ohm non-inductive resistor and a VTVM across terminals 11 and 12. Energize the transmitter and output control R-42 for the same output as the maximum noise. Then adjust the receiver input control R-1 to obtain 1-ma output current. If it is impossible to obtain 1-ma output current with control R-1 in the maximum clockwise position, then clip out resistor R-74, which is connected to the base of Q-4. If the gain is still insufficient, clip out resistor R-73, which is connected to the base of Q-5. After completing the adjustment of R-1, restore the transmitter to full output.

b. Sensitivity Adjustment for Remote Signal

When the maximum on-frequency noise is unknown and cannot be conveniently measured, the receiver may be adjusted for the remote signal. First determine the channel attenuation using a Sierra voltmeter or some other convenient method. Disconnect the coaxial cable and connect a 60-ohm non-inductive resistor and a VTVM across terminals 11 and 12. Add 15-db to the channel attenuation. This compensates for average variations such as channel and voltage variations. For example, if the channel attenuation is 5-db, add this to the 15-db making a total of 20-db. Taking this from 8 volts output of the transmitter, the receiver should then be set for a sensitivity of 0.8 volts. To do this, adjust the transmitter output control R-42 for 0.8 volts and then adjust the receiver input control so as to obtain 10-ma output current. If it is impossible to obtain 10-ma output current with control R-1 in the maximum clockwise position, clip out resistor R-74, which is connected to the base of Q-4. If the gain is still insufficient, clip out resistor R-73, which is connected to the base of Q-5. After completing the

adjustment of R-1, restore the transmitter to full output.

It must be kept in mind that the two preceding adjustment procedures are to be used as a guide and will cover the majority of cases; however, cases may arise where conditions change. For example, if the adjustment is made per part a., the noise may increase due to various reasons such as bad insulators, which would require adjusting the receiver to be less sensitive. In the adjustment of part b., the attenuation may increase due to sleet or line switching, which would necessitate increasing the sensitivity of the receiver.

Reserve Signal Detector

Due to different types of operation and supply voltages, it is not practical to have a calibrated dial for this unit. However, calibration may be made at installation by recording transmitter output (either in db or volts) at various knob settings of the detector unit. Then, by adjusting the knob so as to obtain 10 milliamperes relay current at a remote receiver, any increase or decrease in line attenuation may be noted as the difference between the original setting, and the setting required to obtain the given 10 milliamperes.

250-Volt Resistor Unit

With the apparatus energized, adjust R-4 in the 250-volt resistor unit so as to obtain 125-volts at terminals 17 (B-) and 19 (B+) on the relaying set.

Frequency Change

If the frequency is changed in the field, it is necessary to change the input filter FL-1 to the desired channel frequency. This filter is of the plug-in type and may be removed by unsnapping the clamp and pulling the filter out. The transmitter oscillator crystal Y-2 must be changed to the desired channel frequency. The receiver oscillator crystal Y-1 must be changed to the desired channel frequency plus 20 * kHz. Figure 9 shows the connections for the transmitter output filter. It is necessary to unsolder the existing connections and make the new connections per the chart. After completing the preceding, the tuning procedure as described under Adjustments for transmitter and receiver should then be followed.

Note also that capacitors C2 and C9 in the transmitter and receiver crystal oscillator circuits, respectively, may have to be changed. For fre-

- * frequencies below 110 kHz, these capacitors are 270 mmf. each. For frequencies of 110 kHz and above, the capacitors are 140 mmf. each.

CAUTION Turn power OFF before removing filters or transistors, as high transient currents may cause permanent damage to the transistors.

MAINTENANCE

Voltage values should be recorded after adjustment in order to establish reference values which will be useful when checking the apparatus. The readings will remain fairly constant over an indefinite period unless a failure occurs. However, if transistors are changed, there may be considerable difference in these readings without the overall performance being affected.

Typical voltage and current values are given as follows. Voltages should be measured with VTVM. Readings may vary as much as $\pm 20\%$.

In the following paragraphs, the transmitter may be unblocked (transmitting) by closing the CARRIER START circuit in the case of HZM relaying, and by opening the CARRIER START circuit in the case of K-DAR and GCY relaying.

1. For D-C pin jack measurements with reference to B-, refer to Table 1.

2. For transistor D-C measurements with reference to B-, refer to Table 2.

3. For D-C bleeder measurements with reference to B-, refer to Table 3.

4. For typical RF signal measurements for receiver, refer to Table 4.

5. For typical RF signal measurements for transmitter, refer to Table 5.

6. Removal of Printed Circuit Board from Flexitest Case.

To remove the printed circuit board, unplug J-15 and J-16 located near the output filter. Loosen the two screws inside the case near the top. Loosen the slotted thumb screws at the lower end of the board and pull these screws out as far as they will extend. Also remove the receiver coaxial cable plug.

Pull board down so as to disengage the terminals, and lift out.

7. Removal of the Output Filter

After the printed board has been removed, remove the screws on the outside of the case at the bottom. Lift out filter and disconnect the coaxial cable.

8. Receiver Filters

Fig. 15 shows typical receiver selectivity curves both RF and IF. If the filters are checked in a test setup, it is necessary to use an accurate signal generator or preferably a signal generator and a frequency counter.

9. Minimum Test Equipment for Installation

a. Milliammeter 0-25 ma DC.

b. 60-ohm 5-watt non-inductive resistor.

c. A-C Vacuum Tube Voltmeter (VTVM). Voltage * range 0.003 to 30 volts, frequency range 60 Hz to 230-kHz, input impedance 7.5 megohms.

d. D-C Vacuum Tube Voltmeter (VTVM)

Voltage Range: 0.15 to 300 volts

Input Impedance: 7.5 megohms

10. Desirable Test Equipment for Apparatus Maintenance

a. All items listed in Sections 8 and 9.

b. Signal Generator

Output Voltage: up to 8 volts

* Frequency Range: 20-kHz. to 230-kHz.

c. Oscilloscope

d. Ohmmeter

e. Capacitor checker

f. Test harness (See Fig. 17)

TABLE 1

D-C PIN JACK MEASUREMENTS WITH REFERENCE TO B-

Description	Jack	CONDITION A Tx-Blocked †† Rx-No Signal		CONDITION B Tx-Blocked Rx-With Signal		CONDITION C Tx-Unblocked Rx-No Signal	
		129 VDC	51 VDC	129 VDC	51 VDC	129 VDC	51 VDC
RF Input	J-2	0	0	0.3 V	0.3 V		
DC Q-1 Base	J-3	20 V	20 V	20 V	20 V		
DC R _x B+	J-4	20 V	20 V	20 V	20 V		
DC R _x Osc	J-5	7 V	7 V	7 V	7 V		
DC Q-5 Base	J-6	20 V	20 V	20 V	20 V		
B-	J-7						
DC-P1-E	J-8	110 V	32 V	110 V	32 V	110 V	32 V
DC-Q-7 Base	J-9	69 V	0 V	78 V	2.3 V	66 V	0.3 V
DC Q-7 Emit	J-10	70 V	1.0 V	78 V	1.4 V	66 V	1.0 V
DC T _x Osc	J-11	7 V	7 V	7 V	7 V	7 V	7 V
B+	J-12	129 V	51 V	129 V	51 V	129 V	51 V
DC Q-10 Base	J-13					18 V	18 V
DC Q-10 Emit	J-14					18 V	18 V
RF ma out	J-15					130 ma	130 ma
DC ma RRH and ALARM				18 ma	* 18 ma		

†† Tx = transmitter, Rx = receiver

TABLE 2

TYPICAL TRANSISTOR DC MEASUREMENTS WITH REFERENCE TO B-

Transistor	Condition A Tx-Blocked Rx-No Signal (Volts)			Condition B Tx-Blocked Rx-With Signal (Volts)			Condition C Tx-Unblocked Rx-No Signal (Volts)		
	E†	B†	C†	E†	B†	C†	E†	B†	C†
Q-1	20.0	20.0	0.38	20.0	20.0	0.4			
Q-2	7	7.2	1.8	7	7.2	1.8			
Q-3	6.2	8.0	2	6.2	8	2.0			
Q-4	20.0	20.0	2.6	20.0	20.0	2.8			
Q-5	20.0	20.0	2.6	20.0	20.0	2.8			
Q-6									
129 VDC	110	110	129	115	114	129			
51 VDC	32	32	51	32	32	51			
Q-7									
129 VDC	70	68	129	78	80	86			
51 VDC	1.0	0	51	1.4	2.2	7.0			
Q-8	6.2	8	2	6.2	8	2	6.2	8	2
Q-9	7	7.2	1.8	7	7.2	1.8	7	7.2	1.8
Q-10††							18	18	0.4
Q-12††							0.27	0.20	50
Q-15††							0.27	0.20	50

† E-Emitter; B-Base; C-Collector.
 †† With respect to term F on printed board.

TABLE 3

D-C BLEEDER MEASUREMENTS WITH REFERENCE TO B-

Measurement	129 VDC			51 VDC		
	A†	B†	C†	A†	B†	C†
Junction R-61 and R-62 (J-8)	110V	110V	110V	32V	32V	32V
Junction R-61 and R-27 (J-10)	70V	78V	66V	1.0V	1.4V	1.0V
Junction R-27 and R-60 (P1-P)	69V	77V	65V	0	0	0
Junction CR-8 and R-64 (P1-K)	58V	58V	58V	51V	51V	51V
Junction R-48 and R-47 (J-14)	—	—	18V	—	—	18V
Junction R-45 and R-47 (TP-9)	—	—	45V	—	—	51V
Junction R-45 and R-41 (TP-8)	—	—	98V	—	—	51V

†Conditions: A — Tx-Blocked, Rx-No Signal; B — Tx-Blocked, Rx-With Signal; C — Tx-Unblocked, Rx-No Signal.

TABLE 4
TYPICAL RF SIGNAL MEASUREMENTS FOR RECEIVER
(Made with 0.1 Volt at Terminal 5 of FL1)

Check Point	25 MV Sensitivity (Volts)	80 MV Sensitivity (Volts)	250 MV Sensitivity (Volts)
With Receiver Crystal Out			
FL1-5 to Gnd.	0.1	0.1	0.1
T1-1 to Gnd.	0.1	0.1	0.1
Q1-E to Gnd.	0.05	0.05	0.05
Q1-C to Gnd.	0.07	0.07	0.07
T3-1 to Gnd.	0.07	0.07	0.07
Q4-C to Gnd.	0.07	0.07	0.07
With Receiver Crystal In			
Q4-C to Gnd.	0.5	0.5	0.25
J6 to Gnd.	0.15	0.1	0.08
Q5-C to Gnd.	7.0	1.7	0.8
Q6-B to Gnd.	2.0	0.5	0.4
Q6-C to Gnd.	13.0	10.0	8.0
T4-1 to Gnd.	13.0	10.0	8.0
T4-3 to T4-4	4.5	3.5	2.5
J9 to J10 (DC)	0.74	0.75	0.65

TABLE 5

TYPICAL RF SIGNAL MEASUREMENTS FOR TRANSMITTER	
CHECK POINT	VOLTS
T5-1 to Gnd.	5.5
T5-3 to Gnd.	1.0
J13 to Gnd.	0.085
Q10-C to Gnd.	6.0
T6-2 to Gnd.	6.0
Q12-B to Gnd.	0.8
Q15-B to Gnd.	0.8
Q12-C to Gnd.	38.0
Q15-C to Gnd.	38.0
T7-5 to Gnd.	9.8
Output to Gnd.	8.0

APPLICATION

1. Receiver Selectivity (Fig. 14)

This shows a typical curve of the overall selectivity of the receiver under steady state conditions.

2. Transmitter Output Selectivity (Fig. 10)

Typical curves are shown so that approximate bandwidths for keying purposes can be determined for any carrier frequency between 30-kHz and 200-kHz.

3. Minimum Channel Spacing (Fig.16)

This is a graph from which minimum channel spacing can be obtained provided the signal strength of the interfering transmitter and the sensitivity setting of the receiver are known. These can be obtained from calculations or by measurements.

For example, if the interfering transmitter voltage is measured (at the receiver) and found to be 2.5

volts, this would be 10-db down from 8 volts. This point can be located on the right hand column of the graph. Then, if the receiver sensitivity were set to operate on 0.8 volts or 20-db, this point would be located on the left hand column. A line could then be drawn through the two points as shown by the dotted line. The intersection of this line with the center line indicates the minimum channel spacing. In this case if the interfering signal is being keyed on-off, at * 15 pps, the minimum spacing would be 2.5-kHz.

4. Transmitter Output and Receiver Sensitivity Variations with Voltage (Fig. 12)

These curves show the variation of transmitter output and receiver sensitivity with changes in supply voltage, at 120-kHz and 25°C. The increase and decrease in transmitter output above or below 1.0 watts may be obtained in db from the transmitter curve. 1.0 watts is about 8.0 volts with a 60-ohm load.

The increase and decrease in receiver sensitivity above or below 40 millivolts can similarly be

TYPE KR CARRIER SET

obtained in db from the receiver curve. 40 millivolts sensitivity represents the input signal required for proper operation.

5. Transmitter Output and Receiver Sensitivity Variations with Frequency (Fig. 13)

These curves show the variation of transmitter output and receiver sensitivity with variation in frequency, at a supply voltage of 129 VDC, and 25°C. They may be used in the same manner as Fig. 12.

6. Supervisory Control Connections (Fig. 7)

When supervisory control is used with relaying, the supervisory control relay coil is connected in

series with the RRH coil in place of the alarm relay. When supervisory control is used alone, a 1200-ohm resistor R3 is connected in series with the control relay coil by removing the jumper across R3, as shown in Fig. 7. In order to maintain proper mark space ratio, the relay bias current is adjusted for 9 milliamperes as indicated.

The receiver RF filter and the IF filter limits are shown on Fig. 15. Both filters are of the plug-in type and the test circuits with pin connections are shown at the top of each curve. The IF filter is divided into two separate sections. The selectivity shown is for each section, and the pin connections for each section are also shown in the test circuit sketch.

ELECTRICAL PARTS LIST

CIRCUIT SYMBOL	FUNCTION	DESCRIPTION	MANUFACTURER'S DESIGNATION
<u>CAPACITORS</u>			
C-1	Rcvr. Bleeder	2.0 μ f, \pm 20%, 200 VDC, Paper	330C567 H11
†C-2	Rcvr. Osc. Feedback	140/270 μ f, \pm 20%, 500 VDC, Mica	330C566 H43 or 330C566 H57
C-3	Rcvr. Osc. Bleeder Bypass	0.02 μ f, MRC, 600 VDC, Disc	330C569 H47
C-5	Q-6 Emitter Bypass	1.0 μ f, \pm 20%, 200 VDC Paper	330C567 H09
C-6	Rcvr. Rectifier Bypass	Same as C-5	
C-7	B- to B+ Bypass	2 μ f, \pm 10%, 600 VDC, Paper	14C9400 H18
C-8	B- to GND	1.0 μ f, \pm 10%, 1000 VDC, Paper	14C9400 H17
†C-9	Xmtr. Osc. Feedback	Same as C-2	
C-10	Xmtr. Osc.	Same as C-3	
C-11	Key Filter	0.1 μ f, \pm 20%, 200 VDC, Paper	330C567 H02
C-12	Q-10 Emitter Bypass	0.25 μ f, \pm 20%, 200 VDC, Paper	330C567 H05
C-13	Q-10 Bleeder Bypass	Same as C-12	
C-14	PA Base Bypass	Same as C-12	

†Note: 140 μ f for osc. freq. 110-kc and above.
270 μ f for osc. freq. below 110-kc.

ELECTRICAL PARTS LIST

CIRCUIT SYMBOL	FUNCTION	DESCRIPTION	MANUFACTURER'S DESIGNATION
<u>CAPACITORS (Concluded)</u>			
C-18	PA Bleeder	0.5 μf , $\pm 20\%$, Paper	330C567 H06
C-19	Output Filter Tuning	500 μf , Variable, Air	328C092 H01
C-20	Output Filter	390 μf , $\pm 5\%$, 2500 VDC, Mica	330C561 H15
C-21	Output Filter	680 μf , $\pm 5\%$, 2500 VDC, Mica	330C561 H21
C-22	Output Filter	1200 μf , $\pm 5\%$, 2500 VDC, Mica	330C561 H27
C-24	FL-2 Decoupling	Same as C-12	
C-25	Q-7 Emitter	12 mfd, $\pm 20\%$, 200 VDC	187A177 H01
<u>CRYSTAL DIODES</u>			
CR-1	Bridge Rectifier	General Purpose, 1N63	584C433 H02
CR-2	Bridge Rectifier	Same as CR-1	
CR-3	Bridge Rectifier	Same as CR-1	
CR-4	Bridge Rectifier	Same as CR-1	
CR-5	Q-10 Collector	Same as CR-1	
CR-6	Q-7 Base-Emitter	Type 1N457A	184A855H07
CR-7	Voltage Regulator	Type 1N768,	584C434 H02
CR-8	Voltage Regulator	Type 1N1369	584C434 H05
CR-9	Q-7 Collector	Type 1N3811	185A089H08
CR-10	Q10 Emitter	Type 1N3028A	188A302H14

ELECTRICAL PARTS LIST

CIRCUIT SYMBOL	FUNCTION	DESCRIPTION	MANUFACTURER'S DESIGNATION
<u>FUSE HOLDERS</u>			
FH-1	B-	For Type 3AGC Fuses	584C271 H02
FH-2	B+	Same as FH-1	
<u>FUSES</u>			
F-1	B-	3AGC 3/4 amp.	S#330C691 H12
F-2	B+	Same as F-1	
<u>FILTERS</u>			
FL-1	Rcvr. RF Bandpass	* 30 to 200 kHz Freq. to be specified by customer	
FL-2	Rcvr. IF Bandpass	* 20-kHz Fixed Freq.	
<u>CONNECTORS</u>			
J-1	Printed Circuit	Printed Circuit Female Plug	54-B-7125 H03
J-2	RF Input	UG-185-U	584C292 H07
J-3	Rcvr. Osc. Output	Terminal Studs	330C592 H01
J-4	Rcvr. Mixer-Amp Supply	Same as J-3	
J-5	Rcvr. Osc. Supply	Same as J-3	
J-6	Q-5 Base	Same as J-3	
J-7	B-	Same as J-3	
J-8	Q-6 Supply	Same as J-3	

ELECTRICAL PARTS LIST

CIRCUIT SYMBOL	FUNCTION	DESCRIPTION	MANUFACTURER'S DESIGNATION
<u>CONNECTORS (Concluded)</u>			
J-9	Q-7 Base	Same as J-3	
J-10	Q-7 Emitter	Same as J-3	
J-11	Xmtr. Osc. Supply	Same as J-3	
J-12	B+	Same as J-3	
J-13	Xmtr. Osc. Output	Same as J-3	
J-14	Q-10 Supply	Same as J-3	
J-15	Output Filter	Banana Tip Red	328C093 H01
J-16	Output Filter GND	Banana Tip Black	328C093 H02
P-1	Printed Circuit	Printed Circuit Male Plug	54-B-7126 H03
<u>INDUCTORS</u>			
L-1	Core and Coil Assembly	11 MH Total — 6 MH Tap (Part of FL-3)	329C450
L-2	Core and Coil Assembly	2.5 MH (Part of FL-3)	329C449
L-3	RF Choke	1.0 MH, 300 ma	R-300
L-4	RF Choke	Same as L-3	
<u>TRANSISTORS</u>			
Q-1	Rcvr. Mixer	Type 2N525	184A638H13
Q-2	Rcvr. Osc.	Type 2N414	184A638H14

ELECTRICAL PARTS LIST

CIRCUIT SYMBOL	FUNCTION	DESCRIPTION	MANUFACTURER'S DESIGNATION
<u>TRANSISTORS (Concluded)</u>			
Q-3	Rcvr. Osc.	Same as Q-2	
Q-4	Rcvr. IF	Same as Q-1	
Q-5	Rcvr. IF	Same as Q-1	
Q-6	Rcvr. IF	Type 2N498 or Type 2N657	184A638H15 184A638H15
Q-7	Rcvr. Output	Type 2N698	762A585H02
Q-8	Xmtr. Osc.	Same as Q-2	
Q-9	Xmtr. Osc.	Same as Q-2	
Q-10	Xmtr. Amp.	Same as Q-1	
Q-12	Xmtr. PA	Type 2N498 or Type 2N657	184A638H07 184A638H15
Q-15	Xmtr. PA	Same as Q-12	
<u>RESISTORS</u>			
R-1	Rec. Input	25 K, $\pm 20\%$, 1/4 W, Pot.	584C276 H23
R-2	Filter Matching	10 K, $\pm 10\%$, 1/2 W	330C595 H37
R-3	Filter Load	Same as R-2	
R-4	Rcvr. Osc.	1 K, $\pm 20\%$, 1/4 W, Pot.	584C276 H19
R-5	Rcvr. Voltage Divider	6.2 K, $\pm 5\%$, 1 W	330C666 H68
R-6	Q-2 Collector	1.2 K, $\pm 5\%$, 1/2 W	330C664 H51
R-8	Rcvr. Voltage Divider	30 K, $\pm 5\%$, 2 W	330C668 H84
R-9	Rcvr. Voltage Divider	Same as R-8	

ELECTRICAL PARTS LIST

CIRCUIT SYMBOL	FUNCTION	DESCRIPTION	MANUFACTURER'S DESIGNATION
		<u>RESISTORS (Continued)</u>	
R-10	Q-2 Base	Same as R-2	
R-11	Q-2 Base	100 K, $\pm 5\%$, 1/2 W	330C665 H05
R-12	Q-3 Collector	Same as R-6	
R-13	Q-3 Emitter	390 Ohms, $\pm 5\%$, 1/2 W	330C664 H39
R-14	Q-3 Base	Same as R-2	
R-15	Q-3 Base	Same as R-11	
R-16	Rcvr. Osc. Bleeder	2.2 K, $\pm 10\%$, 1/2 W	330C595 H41
R-17	Rcvr. Osc. Bleeder	18 K, $\pm 10\%$, 2 W	330C597 H40
R-18	Rcvr. Osc.	9.1 K, $\pm 5\%$, 1/2 W	330C664 H72
R-19	Q-4 Bias	100 Ohms, $\pm 5\%$, 1/2 W	330C664 H25
R-20	Q-4 Bias	Same as R-2	
R-21	Q-5 Bias	150 Ohms, $\pm 5\%$, 1/2W	330C664 H29
R-22	Q-5 Bias	Same as R-2	
R-23	Q-6 Bias	330 Ohms, $\pm 5\%$, 1/2 W	330C664 H37
R-24	Q-6 Bias	Same as R-2	
R-25	Q-6 Emitter	Same as R-19	
R-26	Q-7 Base	Same as R-6	
R-27	Q-7 Bias	20 Ohms, $\pm 5\%$, 1/2 W	330C664 H08
R-28	Xmtr. Osc. Bleeder	Same as R-18	
R-29	Xmtr. Osc. Bleeder	Same as R-17	
R-30	Xmtr. Osc. Bleeder	Same as R-16	

ELECTRICAL PARTS LIST

CIRCUIT SYMBOL	FUNCTION	DESCRIPTION	MANUFACTURER'S DESIGNATION
		<u>RESISTORS (Continued)</u>	
R-31	Q-8 Base	Same as R-11	
R-32	Q-8 Base	Same as R-2	
R-33	Q-8 Emitter	Same as R-13	
R-34	Q-8 Collector	Same as R-6	
R-35	Q-9 Base	Same as R-11	
R-36	Q-9 Base	Same as R-2	
R-37	Q-9 Collector	Same as R-6	
R-38	Key Filter	Same as R-23	
R-39	Buffer Voltage Divider	36 K, $\pm 5\%$, 2 W	330C668 H86
R-40	Buffer Voltage Divider	Same as R-39	
R-41	Buffer Voltage Divider	Same as R-2	
R-42	Xmtr. Osc. Output	Same as R-4	
R-43	Q-10 Bias	Same as R-23	
R-44	Q-10 Bias	33 K, $\pm 5\%$, 1/2 W	330C664 H85
R-45	Buffer Voltage Divider	15 K, $\pm 10\%$, 1 W	330C596 H39
R-47	Buffer Voltage Divider	6.8 K, $\pm 5\%$, 1/2 W	330C664 H69
R-48	Buffer Voltage Divider	15 K, $\pm 5\%$, 1/2 W	330C664 H77
R-49	PA Bias	27 K, $\pm 5\%$, 2 W	330C668 H83

ELECTRICAL PARTS LIST

CIRCUIT SYMBOL	FUNCTION	DESCRIPTION	MANUFACTURER'S DESIGNATION
		<u>RESISTORS (Concluded)</u>	
R-50	Xmtr. PA	Same as R-19	
R-52	Q-12 Emitter	10 Ohms, $\pm 5\%$, 1/2 W	330C664 H01
R-55	Q-15 Emitter	Same as R-52	
R-59	Xmtr. Bleeder	47 Ohms, $\pm 10\%$, 1/2 W	330C595 H09
R-60	Recvr. Bleeder	1 K, $\pm 5\%$, 25 W	584C416 H57
R-61	Recvr. Bleeder	600 Ohms, $\pm 5\%$, 25 W	584C416 H47
R-62	Recvr. Bleeder	350 Ohms, $\pm 5\%$, 25 W	584C416 H52
R-64	Xmtr. Bleeder	1200 Ohms, $\pm 5\%$, 25 W	584C416 H64
R-66	T-7 Load	560 Ohms, $\pm 5\%$, 2 W	330C668 H43
R-67	Xmtr. Blocking	10 Ohms, $\pm 5\%$, 2 W	330C668 H01
R-68	Xmtr. Blocking	10 K, $\pm 10\%$, 10 W	330C577 H01
R-69	Q-10 Emitter	Same as R-19	
R-70	FL2 Decoupling	470 Ohms, $\pm 10\%$, 1/2 W	330C595 H21
R-71	Q-4 Emitter	150 Ohms, $\pm 10\%$, 1/2 W	330C595 H15
R-72	Q-5 Emitter	68 Ohms, $\pm 10\%$, 1/2 W	330C595 H11
R-73	Q-5 Base	180 Ohms, $\pm 10\%$, 1/2 W	330C595 H16
R-74	Q-4 Base	2.7 K, $\pm 5\%$, 1/2 W	330C664 H59
R-75	Q-4 Collector	22 K, $\pm 10\%$, 1/2 W	330C595 H41
R-76	Q-5 Collector	Same as R-75	

ELECTRICAL PARTS LIST

CIRCUIT SYMBOL	FUNCTION	DESCRIPTION	MANUFACTURER'S DESIGNATION
<u>TRANSFORMERS</u>			
T-1	Rcvr. Input	Impedance Ratio 10 K; 10K	S#1962798, L-633005
T-2	Rcvr. Osc.	Impedance Ratio 10 K: 400 ohms	S#1962797, L-633003
T-3	Rcvr. Mixer	Impedance Ratio 25 K: 300 ohms	S#1962697, L-592171
T-4	IF Output	Impedance Ratio 4 K: 500 ohms	S#1962693, L-592289
T-5	Xmtr. Osc.	Same as T-2	
T-6	Xmtr. Buffer	Impedance Ratio 10 K: 400 ohms CT	S#1962698, L-592170
T-7	Xmtr. Output	Impedance Ratio 1930: 60	S#1962694, L-633000
<u>TEST POINTS</u>			
TP-1	R-5	Terminal studs	330C592 H02
TP-2	R-8	Same as TP-1	
TP-3	R-17	Same as TP-1	
TP-4	R-18	Same as TP-1	
TP-5	R-28	Same as TP-1	
TP-6	R-39 & R-40	Same as TP-1	
TP-7	R-41	Same as TP-1	
TP-8	R-45	Same as TP-1	
TP-9	R-47	Same as TP-1	

ELECTRICAL PARTS LIST

CIRCUIT SYMBOL	FUNCTION	DESCRIPTION	MANUFACTURER'S DESIGNATION
<u>SOCKETS</u>			
X-1	FL-1	Octal	330C689 H01
X-2	FL-2	Same as X-1	
X-4	Rear Mounted Voice Adaptor	Same as X-1	
XY-1	Rec. Y-1	Crystal	584C606 H01
XY-2	Xmtr. Y-2	Same as XY-1	
<u>CRYSTALS</u>			
Y-1	Rcvr. Osc.	Specify Channel Freq. * Plus 20-kHz.	328C083
Y-2	Xmtr. Osc.	Specify Freq. Same as Channel Frequency	328C083
<u>RESERVE SIGNAL DETECTOR</u> (S#470D167G02)			
R-1	Resistor, Level Control	* 200 K, 2 W, Pot.	* 184A086H27
R-2	Resistor, Limiting	2000 ohms, 2" tube.	1267296
S-1	Test Switch	SPST Normally Open	327C854 H01

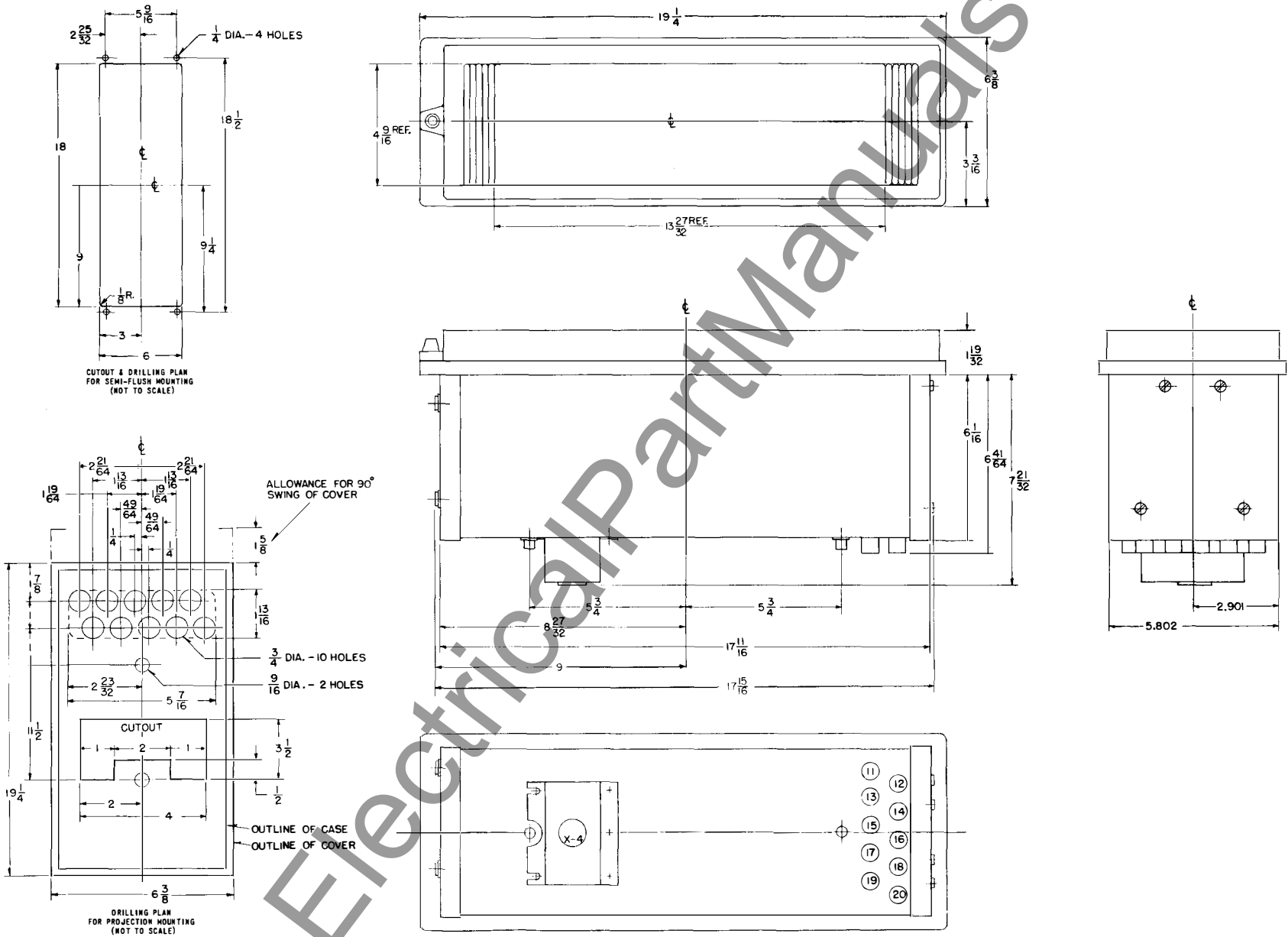
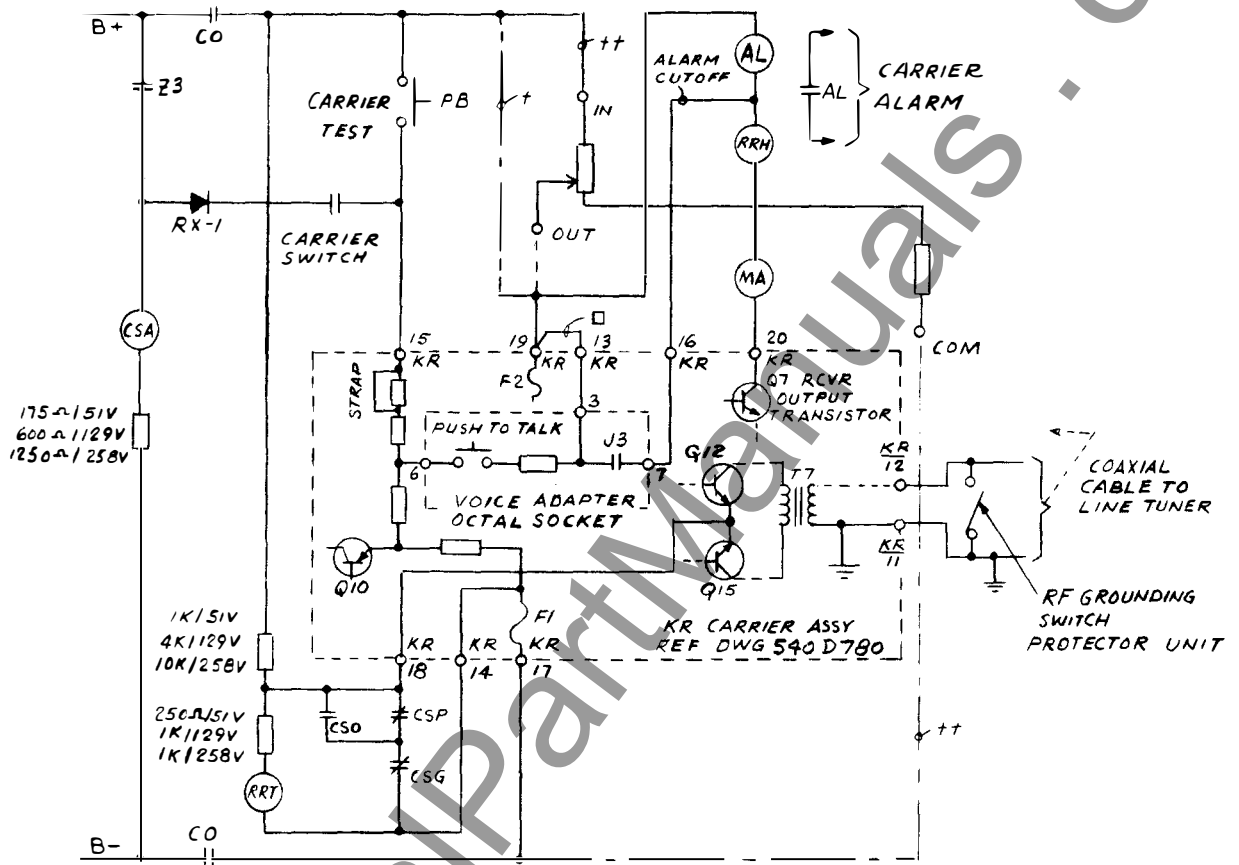

Fig. 1 Outline Drawing, (Flexitest Case) (540D753)

TYPE KR CARRIER SET



REQUIREMENTS FOR HZ/HZM RELAYING

SUPPLY VOLTAGE	CARRIER START	CARRIER STOP	STRAP
51VDC	+51V. 7MA	+28V	IN
129VDC	+129V. 8MA	+40V	IN
258VDC	+258V. 8MA	+40V	OUT

NOTES

- + FOR 51 & 129 VDC SUPPLY.
- ++ FOR 258 VDC SUPPLY USE 330C191H01 RESISTOR UNIT REF DWG 223B497
- FOR SUPERVISORY CONTROL PREFERENCE CONTACTS.

- KR RELAYING TRANSMITTER / RECY EXTERNAL CONNECTIONS
- TERMINAL CONNECTION
- 11 GROUND
 - 12. COAXIAL CABLE
 - 13. SUPERVISORY PREFERENCE CONTACT
 - 14. CARRIER STOP B- RETURN
 - 15. CARRIER START (POSITIVE)
 - 16. ALARM CUTOFF FOR COMMUNICATIONS
 - 17. B MINUS
 - 18. CARRIER STOP (HZ/HZM)
 - 19. B PLUS
 - 20. RELAY COIL

Fig. 3- Relaying Control Circuits - HZ/HZM (Dwg. 1-329C704)

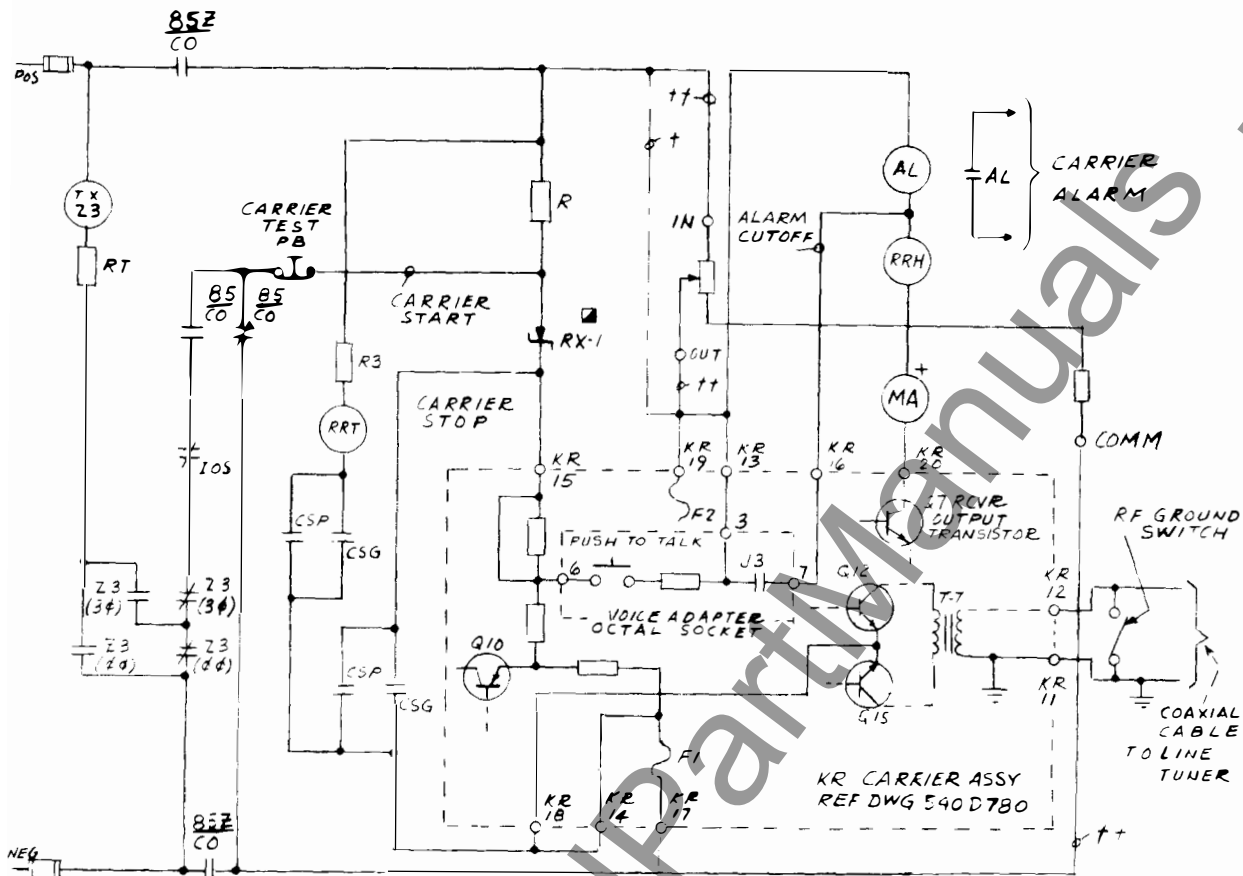

REQUIREMENTS FOR K DAR RELAYING

SUPPLY VOLTAGE	CARRIER START	CARRIER STOP	R
51 VDC	+ 37V 7MA	C VOLTS	2K
129 VDC	+ 100V 2 MA	C VOLTS	3.75K
258 VDC	+ 100V 2 MA	C VOLTS	19K

KR RELAYING TRANSMITTER /
REC'D EXTERNAL CONNECTIONS

TERMINAL CONNECTION:

- 11 GROUND
- 12 COAXIAL CABLE
- 13 SUPERVISORY PREFERENCE CONTACT
- 14 CARRIER STOP B- RETURN
- 15 CARRIER START (POSITIVE)
- 16 ALARM CUTOFF FOR COMMUNICATIONS
- 17 E MINUS
- 18 CARRIER STOP (HZ/HZM)
- 19 B PLUS
- 20 RELAY COIL

NOTES

- * FOR R USE OHMITE VITREOUS ENAMELED DIVIDABLE ADJUSTABLE 4K OR 24K 25W RESISTOR. CONNECT & ADJUST FOR VALUES SHOWN.
- ▲ TYPE 113051 IN CARRIER AUX. RELAY
- + FOR 51 & 129 VDC SUPPLY
- ++ FOR 258VDC SUPPLY USE 330C191401 RESISTOR UNIT REF DWG 223.9.197

* Fig. 4-Relaying Control Circuits-K-Dar (Dwg. 3-329C704)

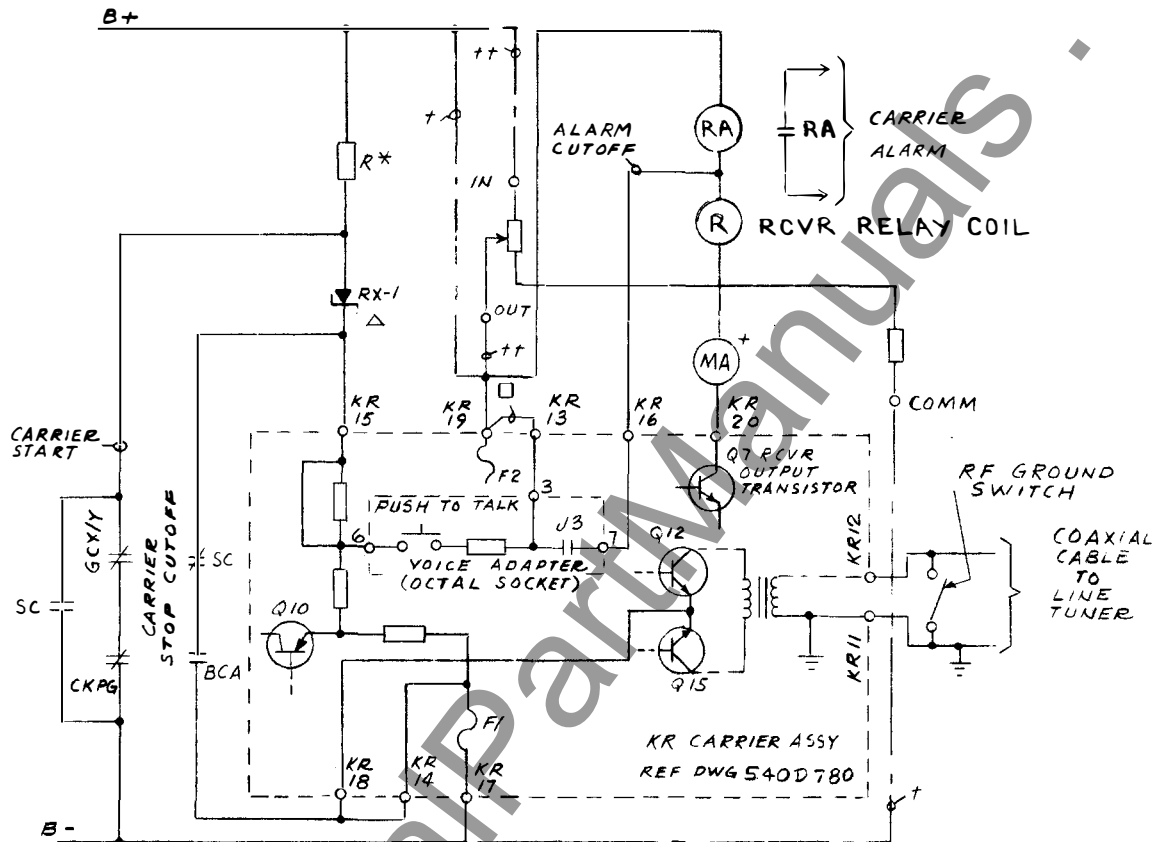

REQUIREMENTS FOR GCX/GCY RELAYING

SUPPLY VOLTAGE	CARRIER START	CARRIER STOP	R
51 VDC	+37V, 7MA	0 VOLTS	2K
129 VDC	+100V, 8MA	0 VOLTS	3.75K
258 VDC	+100V, 8MA	0 VOLTS	19.K

- KR RELAYING TRANSMITTER /
RCV. EXTERNAL CONNECTIONS
TERMINAL CONNECTION
11. GROUND
 12. COAXIAL CABLE
 13. SUPERVISORY PREFERENCE CONTACT
 14. CARRIER STOP B- RETURN
 15. CARRIER START (POSITIVE)
 16. ALARM CUTOFF FOR COMMUNICATIONS
 17. B MINUS
 18. CARRIER STOP (HZ/HZM)
 19. B PLUS
 20. RELAY COIL

- NOTES
- * FOR "R" USE OHMITE VITREOUS ENAMELED DIVIDOHM ADJUSTABLE 4K OR 20K 25W RESISTOR, CONNECT & ADJUST FOR VALUES SHOWN
 - △ TYPE IN 3051
 - + FOR 51 & 129 VDC SUPPLY
 - ++ FOR 258VDC SUPPLY USE 330C191H01 RESISTOR UNIT REF DWG 223B 497
 - FOR SUPERVISORY CONTROL PREFERENCE CONTACTS

Fig. 5. Relaying Control Circuits-GCX/GCY (Dwg. 2-329C704)

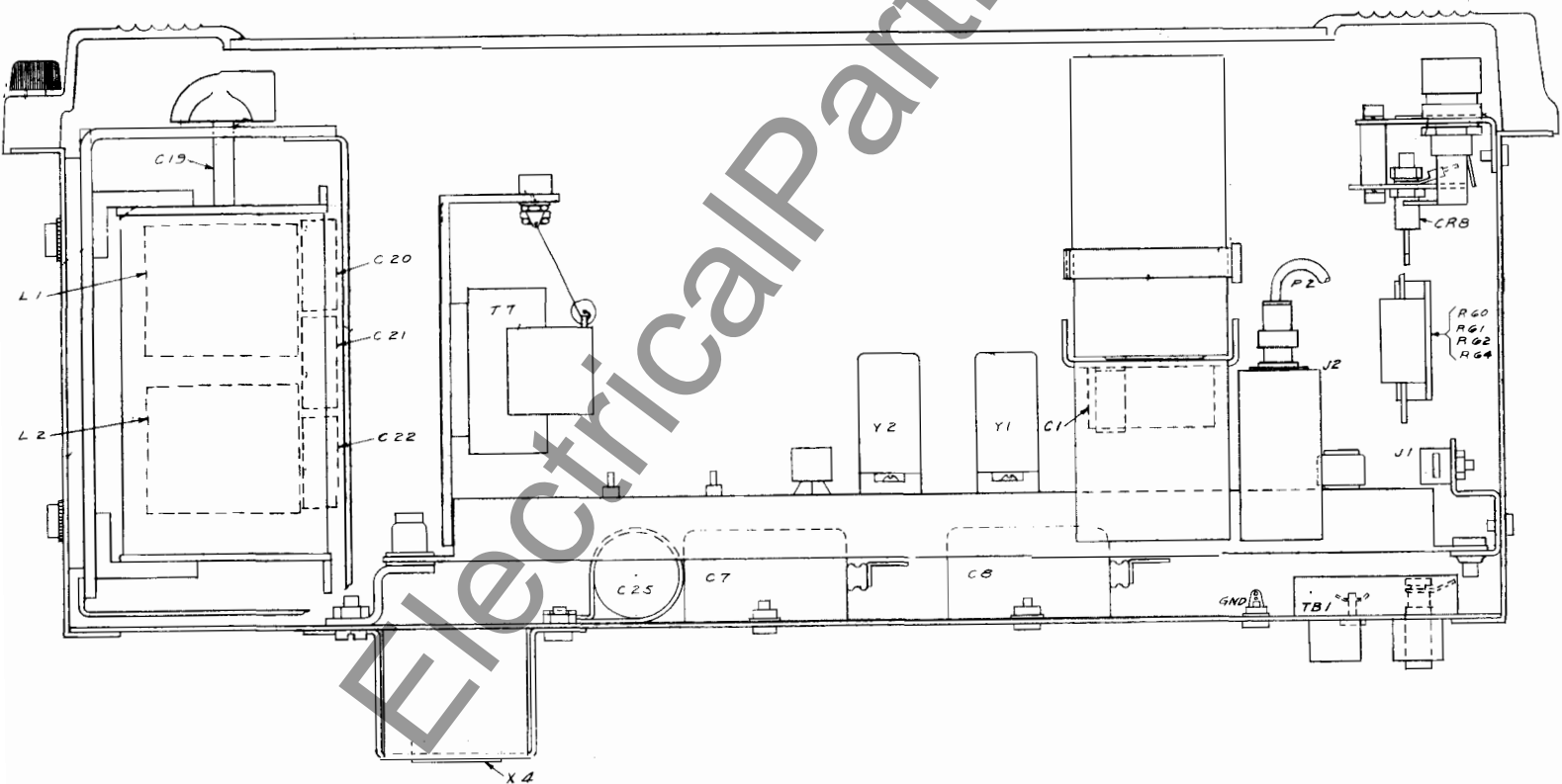
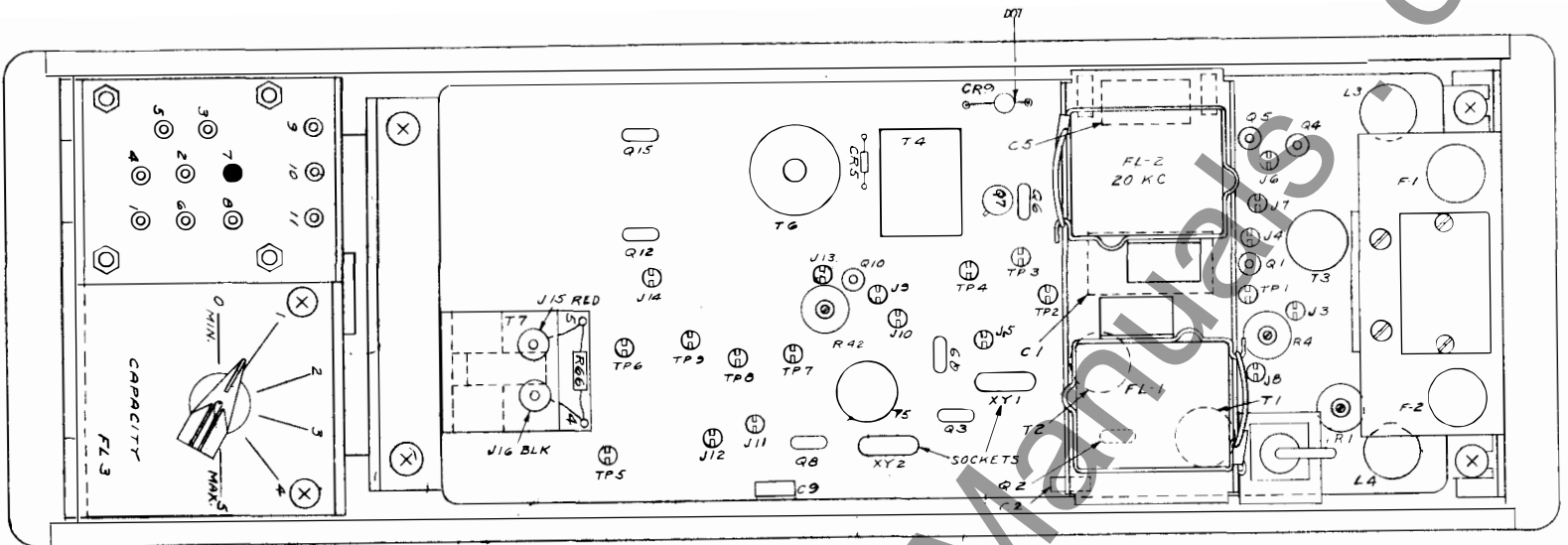
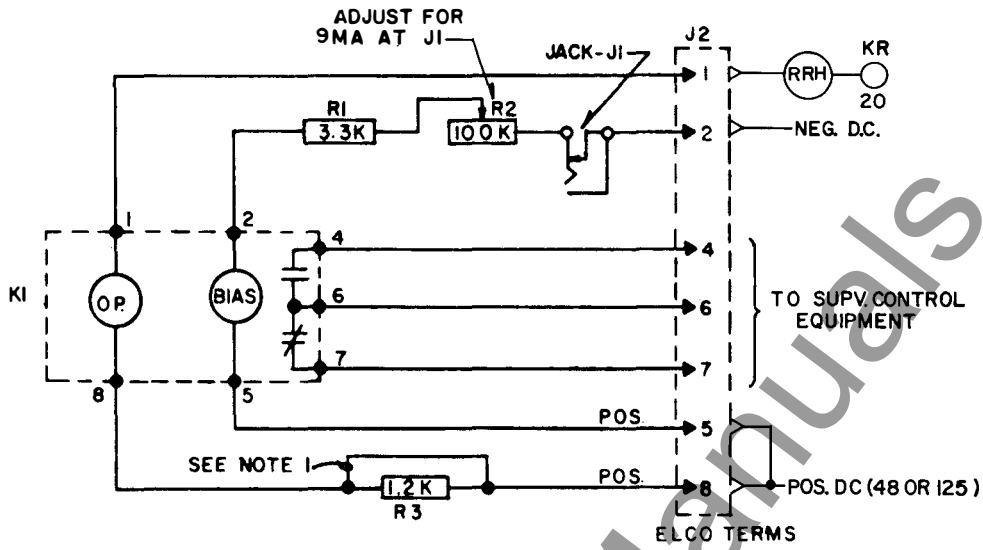
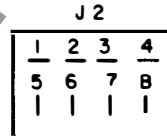

Fig. 6. Component Location (Dwg. 540D781)



NOTES:

1. REMOVE FOR KR CARRIER PLUS SUPV. CONTROL WITHOUT RELAYING.
2. POLARITY SHOWN CLOSES CONTACT BETWEEN TERMINALS 4 & 6.



AS VIEWED FROM REAR OF PANEL

629A552

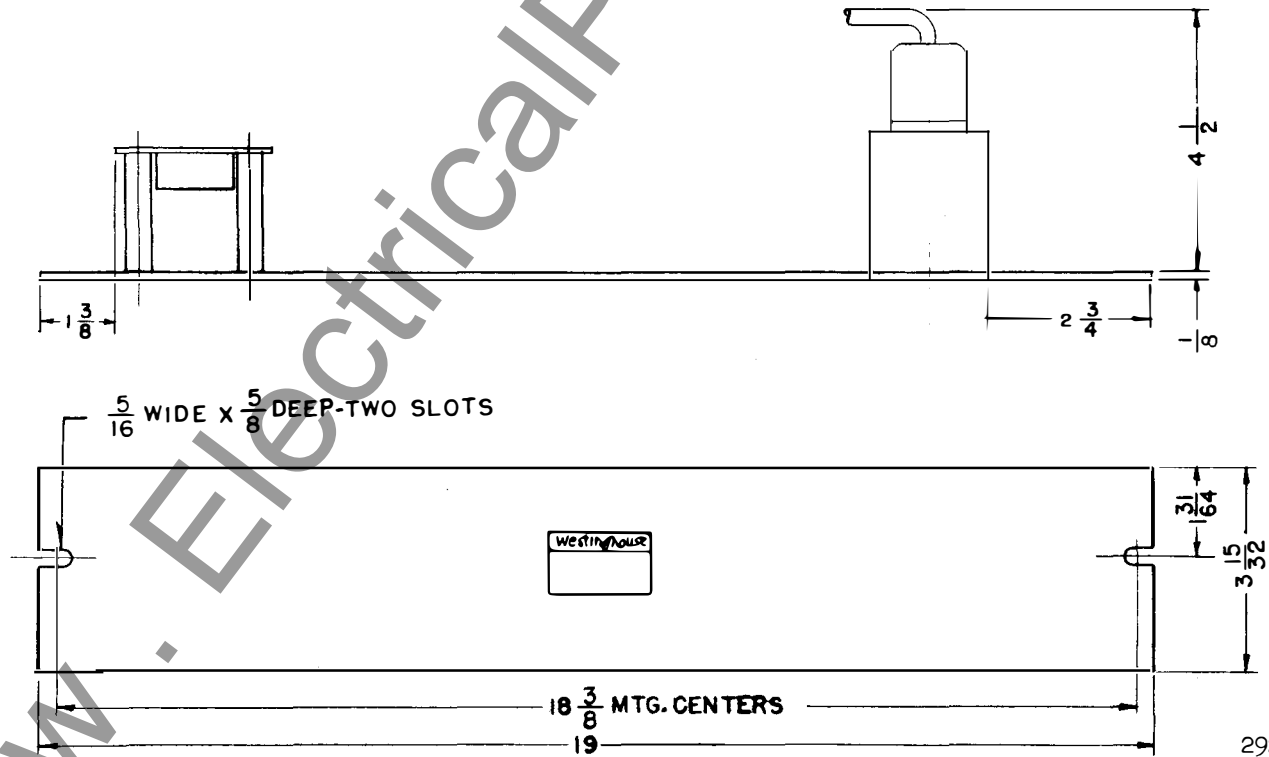

292B991

Fig. 7. Supervisory Control Auxiliary Relay Connections (Dwg. 629A552) and Outline (Dwg. 292B991).

**CONNECTIONS FOR 48-250 VOLT SERVICE AND
SUPERVISORY CONTROL APPLICATION**
(CHANGES FROM JUMPERS SHOWN ON INTERNAL SCHEMATIC, FIG.2)

250-VOLT OPERATION

FOR A 250 VOLT SUPPLY, RESISTOR UNIT 330C191H01 IS USED AS SHOWN ON APPLICATION DRAWING 329C704

FOR HZ/HZM OPERATION, THE JUMPER HAS BEEN REMOVED FROM TP-6 TO TP-7. (NOT REMOVED FOR K-DAR RELAYING).

RESISTOR UNIT SCHEMATIC:

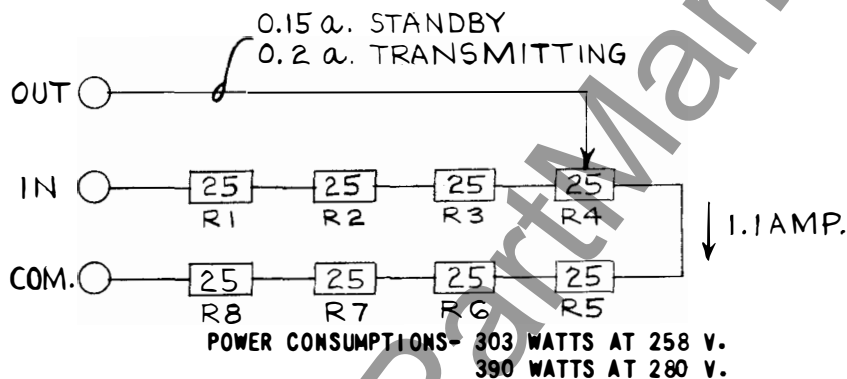

NOTE: KR SUPPLY VOLTAGE WILL BE APPROXIMATELY 144 VOLTS UNDER STANDBY CONDITION WHEN BATTERY VOLTAGE IS 280 VOLTS.

125-VOLT HZ/HZM OPERATION

JUMPER TP-7 AND TP-8 IS REMOVED.

48 VOLT OPERATION

ON PRINTED CIRCUIT BOARD ADDITIONAL JUMPERS ARE CONNECTED AS FOLLOWS:

- BETWEEN TP8 AND TP9
- BETWEEN TP5 AND J12
- BETWEEN TP1 AND TP2
- BETWEEN TP3 AND TP4

IN THE FT CASE, JUMPERS ARE CONNECTED ACROSS R60 AND R64, AND THE CONNECTION BETWEEN R64 AND DIODE CR8 IS REMOVED.

IN ADDITION, FOR 48-VOLT SUPERVISORY CONTROL, R59 IS CONNECTED INTO THE CIRCUIT.

Fig. 8. Connections, 48-250 Volts and Supervisory Control (Dwg. 407C971)

TRANSMITTER OUTPUT FILTER FL-3 CONNECTIONS

<u>LINE</u>	<u>FREQUENCY RANGE</u>	<u>COIL</u>	<u>COIL CONNECTIONS</u>	<u>PARALLEL CAPACITOR CONNECTIONS</u> Δ
1	27.7 KHZ-30.0 KHZ	L-1	(1-5) (3-6)	6-8-9-10-11
2	29.8 KHZ-33.1 KHZ	L-1	(1-5) (3-6)	6-8-10-11
3	31.8 KHZ-36.0 KHZ	L-1	(1-5) (3-6)	6-8-9-11
4	35.4 KHZ-39.0 KHZ	L-1	(1-5) (3-6)	6-8-11
5	38.0 KHZ-41.0 KHZ	L-1	(1-2) (3-6)	6-8-9-10-11
6	40.3 KHZ-45.0 KHZ	L-1	(1-2) (3-6)	6-8-10-11
7	43.0 KHZ-49.0 KHZ	L-1	(1-2) (3-6)	6-8-9-11
8	47.7 KHZ-56.0 KHZ	L-1	(1-2) (3-6)	6-8-11
9	49.5 KHZ-58.5 KHZ	L-1	(1-2) (3-6)	6-8-9-10
10	57.0 KHZ-72.3 KHZ	L-1	(1-2) (3-6)	6-8-10
11	67.0 KHZ-76.0 KHZ	L-2	(1-4) (6-7)	6-8-9-11
12	75.0 KHZ-88.0 KHZ	L-2	(1-4) (6-7)	6-8-11
13	77.5 KHZ-93.0 KHZ	L-2	(1-4) (6-7)	6-8-9-10
14	89.3 KHZ-114.5 KHZ	L-2	(1-4) (6-7)	6-8-10
15	102.7 KHZ-147.0 KHZ	L-2	(1-4) (6-7)	6-8-9
16	136.6 KHZ-210.0 KHZ	L-2	(1-4) (6-7)	6-8

Δ =CONNECTION FROM 6 TO 8 IS MADE BENEATH TERMINAL PLATE ON ALL SETS AT THE FACTORY.

* Fig. 9. Connections - Output Filter (Dwg. 149A420)

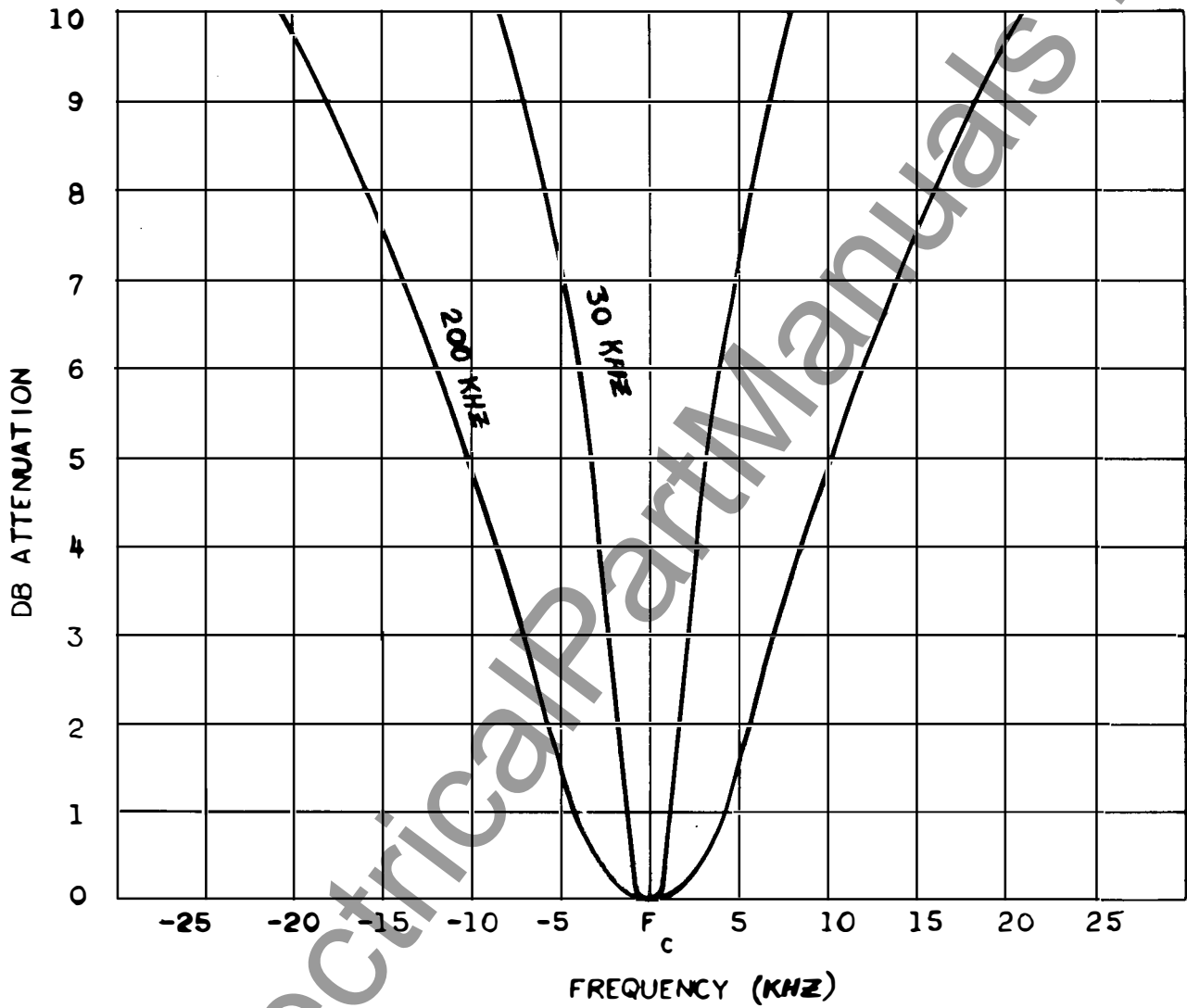

* Fig. 10. Transmitter Output Filter Selectivity (Dwg. 377996)

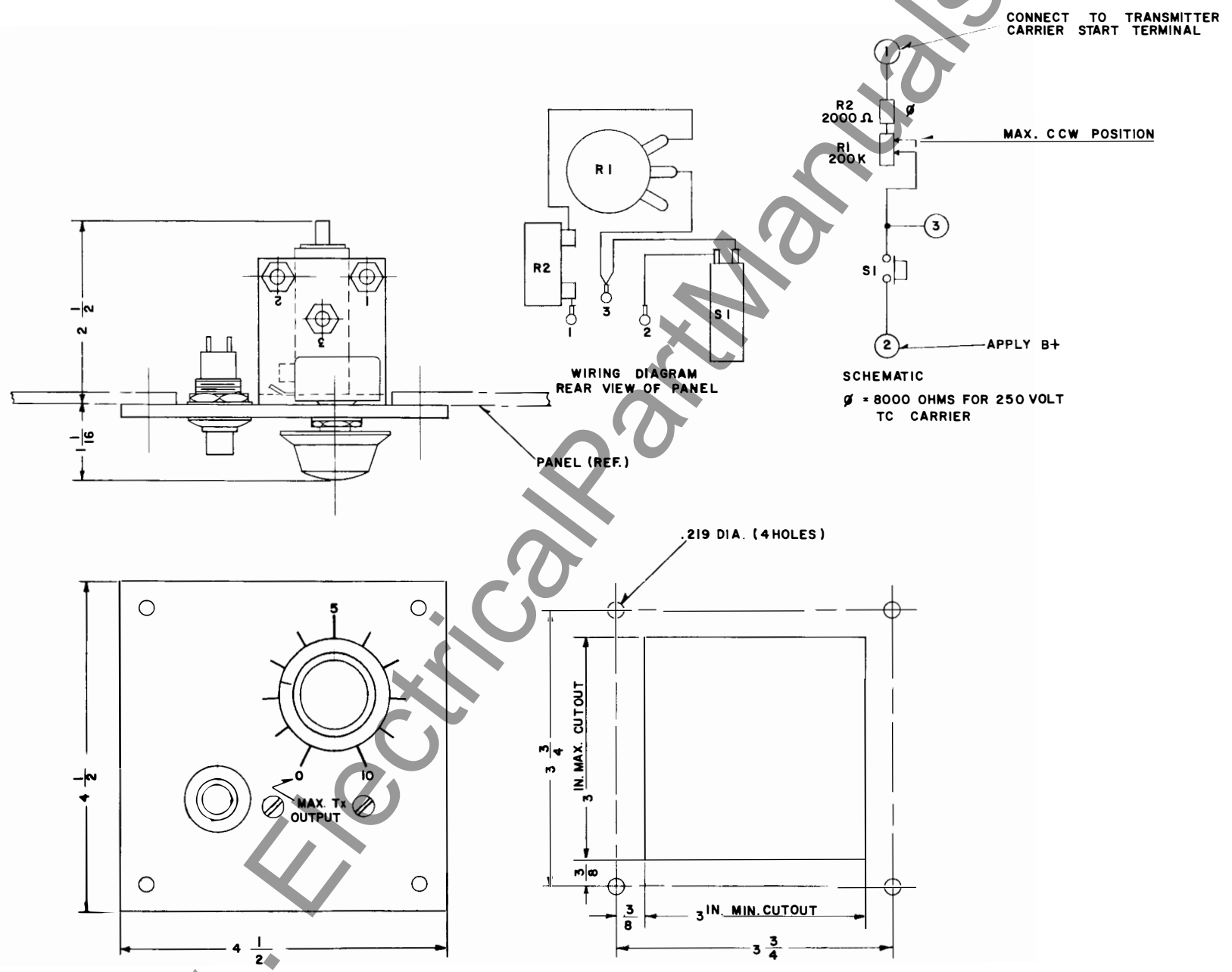

* Fig. 11. Reserve Signal Detector Outline (Dwg. 329C703)

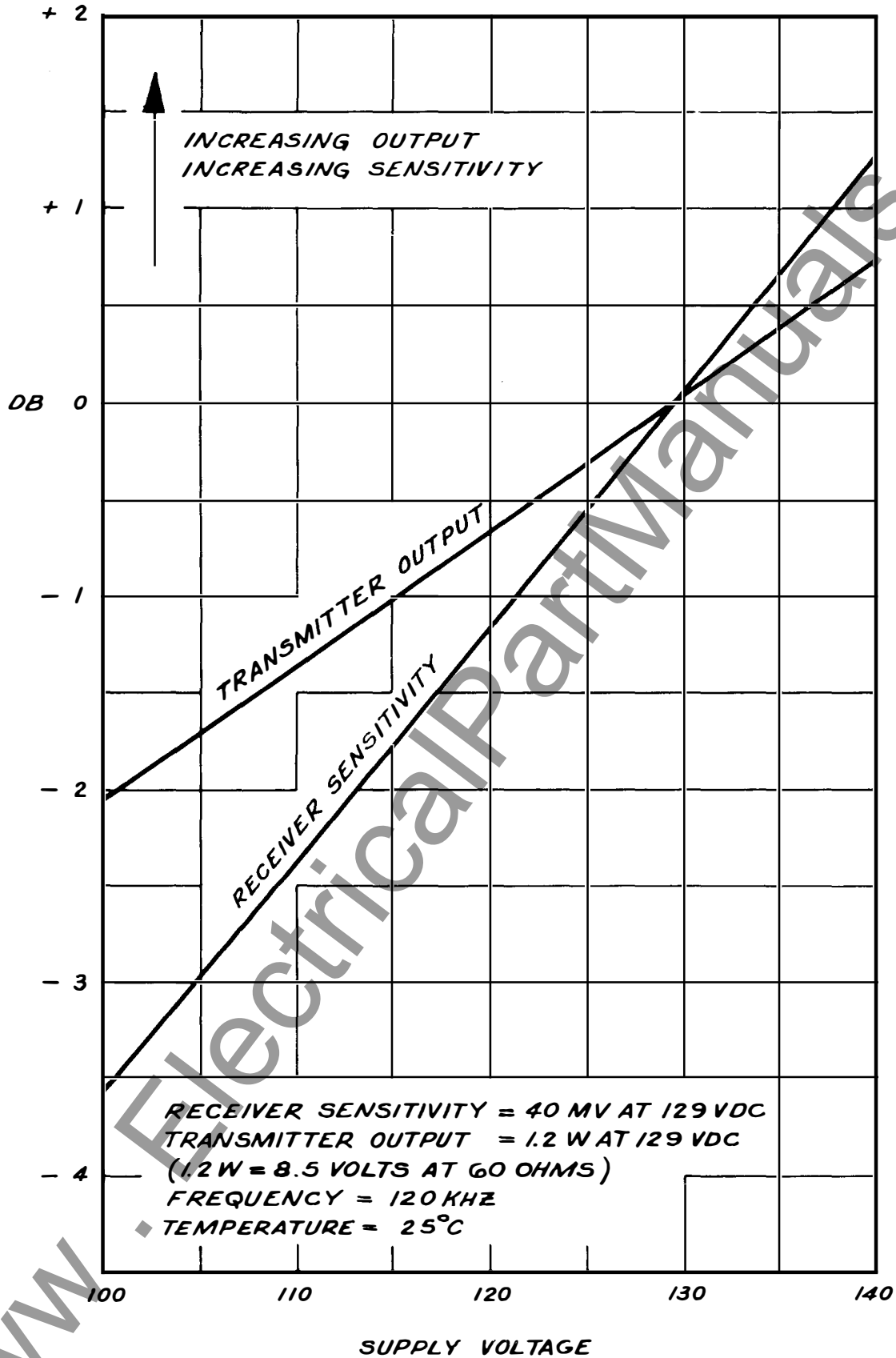

* Fig. 12. Transmitter Output and Receiver Sensitivity Variations with Voltage (Curve # 377999)

TRANSMITTER OUTPUT & RECEIVER SENSITIVITY
VARIATIONS WITH FREQUENCY

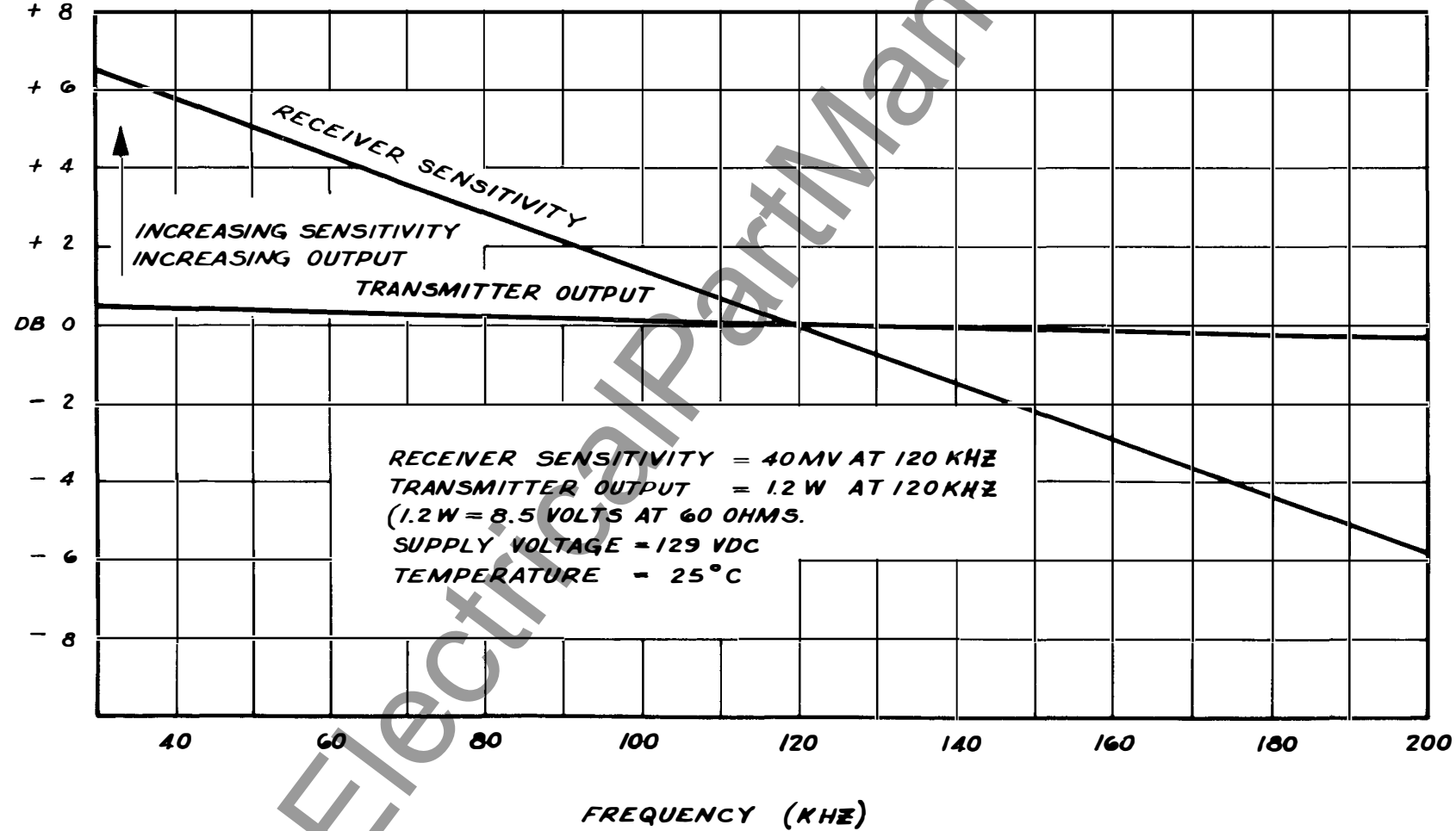

* Fig. 13. Transmitter Output and Receiver Sensitivity Variations with Frequency (Curve# 378000)

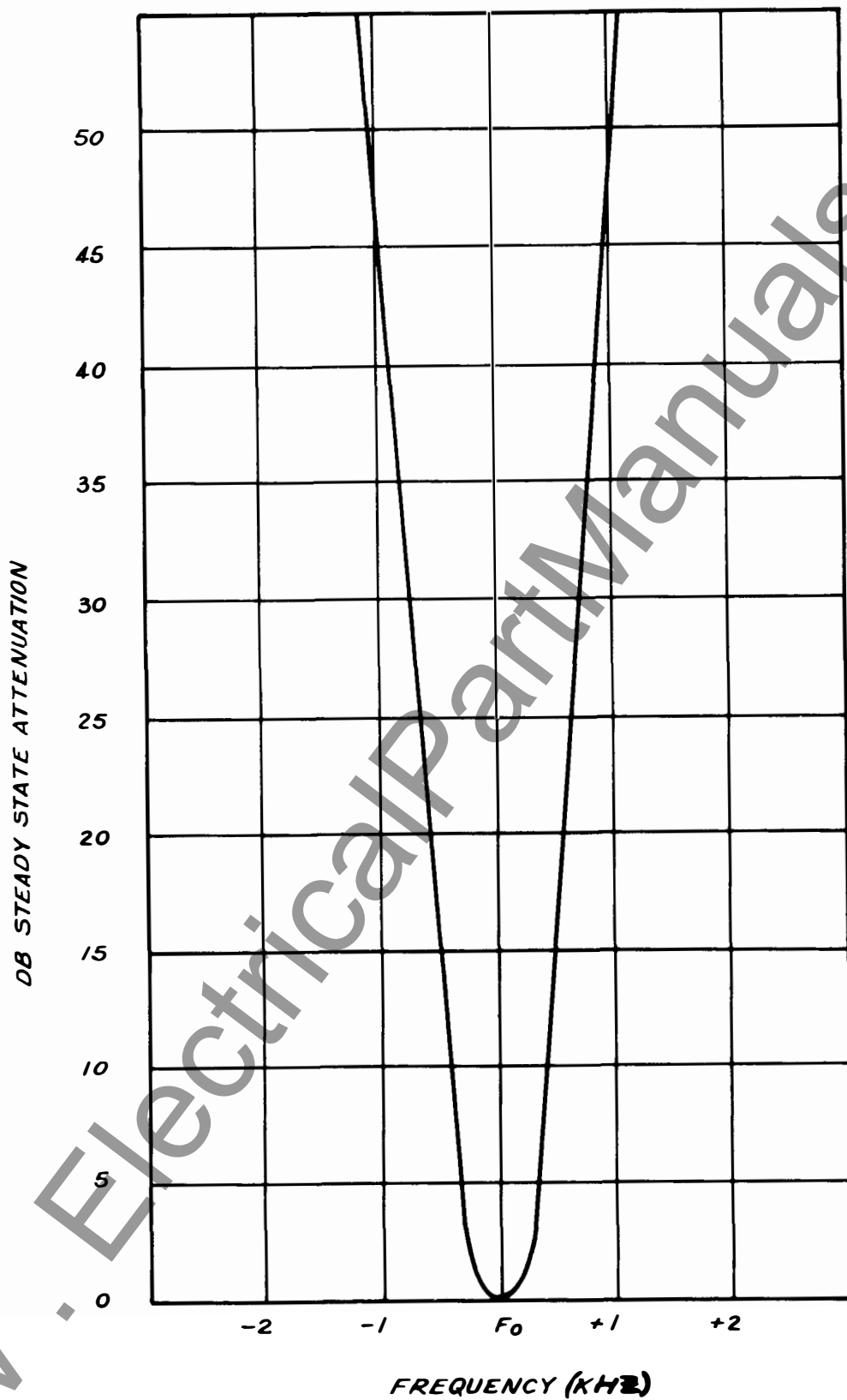

* Fig. 14. Receiver Selectivity (Curve# 377993)

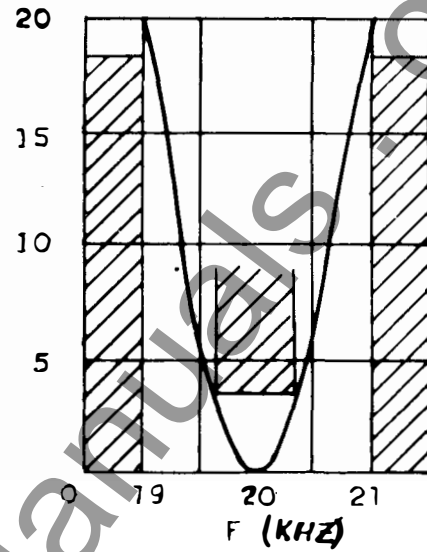
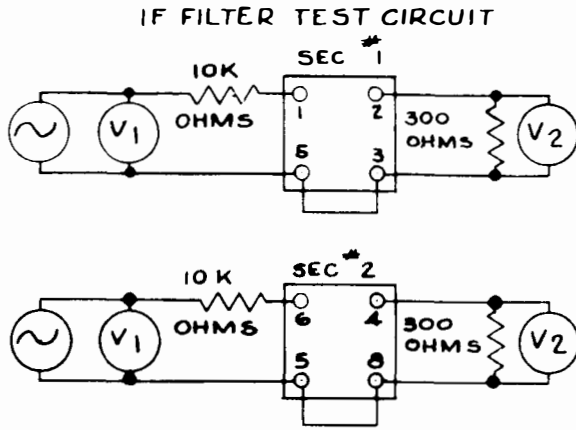

Each section of FL-2 requirement with typical selectivity curve. Insertion loss 26 DB max. Including matching resistor.

FOR BOTH CURVES

$$DB = 20 \log \frac{V_1}{V_2}$$

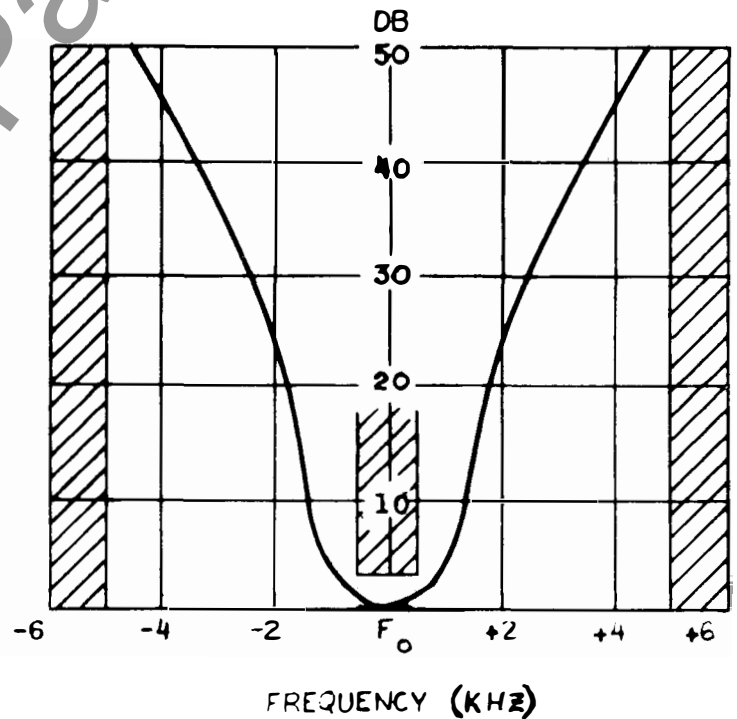
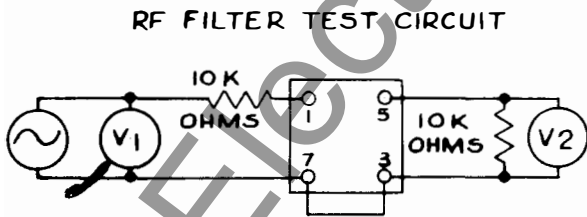

FL-1 Requirement with typical selectivity curve at 120 KHZ. Insertion loss 18 DB max. Including matching resistor.

* Fig. 15. Receiver Filter Limits (Curve# 377995)

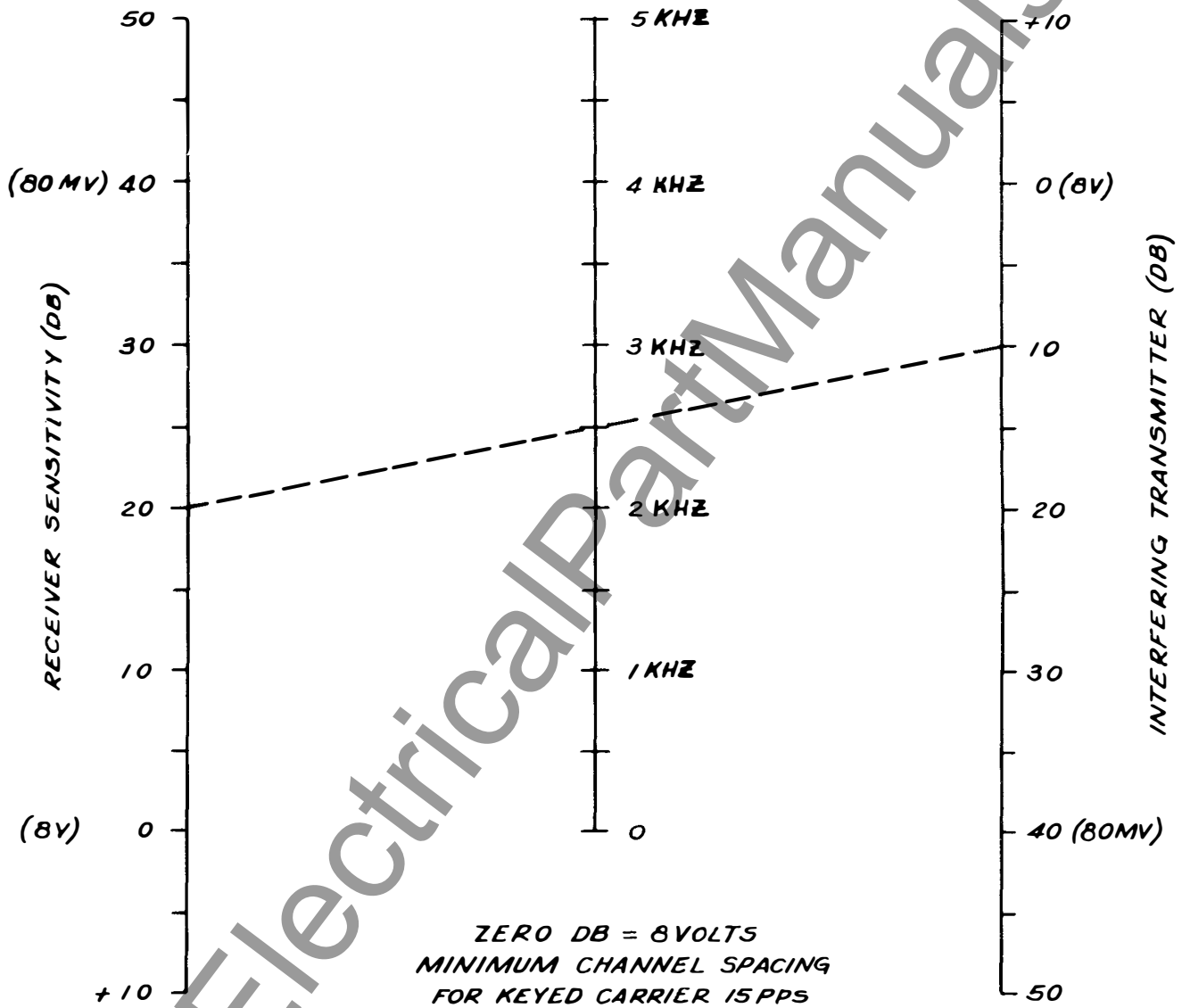

* Fig. 16. Minimum Channel Spacing (Curve# 377998)

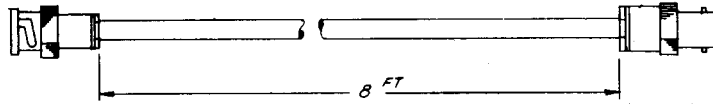

Coaxial Lead...756D346 G02

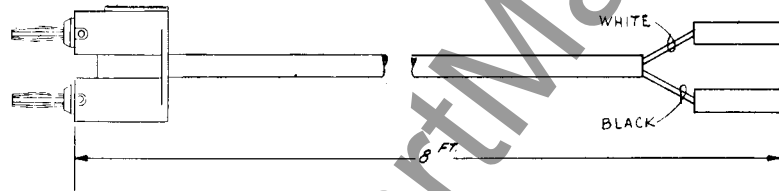

Output Lead...756D346 G03

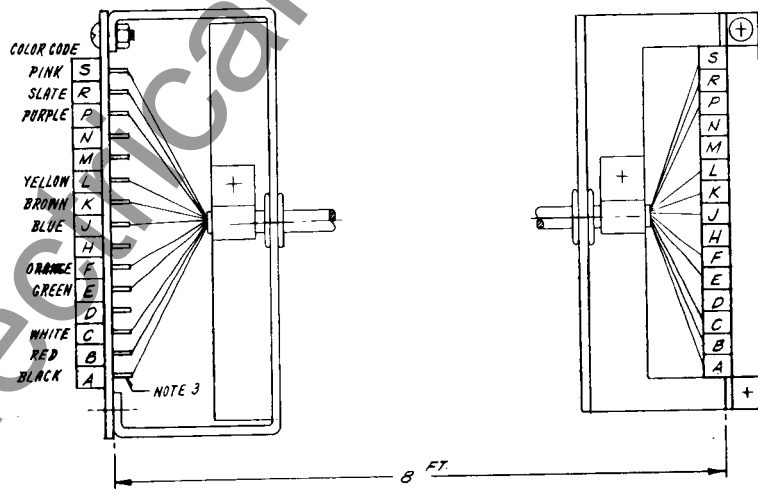

Main Harness...756D346 G04

Fig. 17. Test Harness - (Complete Set)

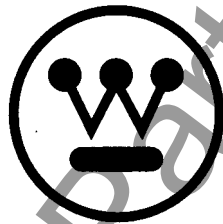

WESTINGHOUSE ELECTRIC CORPORATION
RELAY-INSTRUMENT DIVISION

NEWARK, N. J.

Printed in U.S.A.

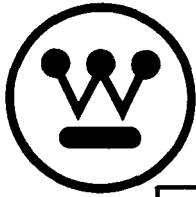

INSTALLATION • OPERATION • MAINTENANCE I N S T R U C T I O N S

TYPE KR CARRIER RELAYING TRANSMITTER-RECEIVER

Flexitest Case Mounted —with provision for rear-mounter Voice Adapter Accessories.	Style
KR Reserve Signal Detector	470D167 G02
250 Volt Resistor Unit	330C191 H01
Test Harness (Complete Set)	756D346 G01
Coaxial Lead	756D346 G02
Output Lead	756D346 G03
Main Harness	756D346 G04

TABLE OF CONTENTS

Introduction	Page 2
Specifications	Page 2
Description	
General	Page 3
Mechanical	Page 3
Electrical	
Transmitter	Page 4
Receiver	Page 4
Transmitter Control Circuits	Page 5
Reserve Signal Detector	Page 5
Communications	Page 5
Relaying Control Circuits	Page 5
Installation	
General	Page 6
Connections	
External	Page 6
Internal	Page 7

Adjustments

Transmitter	Page 7
Receiver	Page 7
Reserve Signal Detector	Page 8
250-Volt Resistor Unit	Page 8
Frequency Change	Page 8
Maintenance	Page 9
Application	Page 13
Electrical Parts List	Page 14

LIST OF TABLES

Table

1 D-C Pin Jack Measurements with Reference to B-	Page 10
2 Transistor DC Measurements with Reference to B-	Page 11
3 D-C Bleeder Measurements with Reference to B-	Page 12
4 Typical RF Signal Measurements for Receiver	Page 12
5 Typical RF Signal Measurements for Transmitter	Page 13

LIST OF ILLUSTRATIONS

Figure	References
1 Outline – Flexitest Case	540D753
2 Internal Schematic	540D780
3 Relaying Control Circuits (HZ/HZM)	1-329C704
4 Relaying Control Circuits (K-Dar)	3-329C704
5 Relaying Control Circuits (GCX/GCY).....	2-329C704
6 Component Location.....	540D781
7 Supervisory Control Receiver Connection.....	223B498
8 Connections, 48-250 volts and Supervisory Control.....	407C971
9 Transmitter Output Filter Connections	149A420
10 Transmitter Output Filter Selectivity.....	C377996
11 Reserve Signal Detector – Outline and Schematic	329C703
12 Transmitter Output and Receiver Sensitivity Variations with D-C Voltage	C377999
13 Transmitter Output and Receiver Sensitivity Variations with Frequency.	C378000
14 Receiver Selectivity	C377993

15 Receiver Filter Limits	C377995
16 Minimum, Channel Spacing	C377998
17 Test Harness	756D346

CAUTION The voltages encountered in this equipment are dangerous to life. To be safe, disconnect the power source and close the grounding switch when servicing the equipment.

INTRODUCTION

The Type KR Relaying Transmitter-Receiver is designed for Distance Relaying, Telemetry, Supervisory Control and Sleet Detection. Facilities are provided for a plug-in type voice adapter. The basic design is for operation from 125-volt station batteries. However, the apparatus may also be operated from 48-volt or 250-volt station batteries by means of various internal connections. These various connections as well as most of the adjustments are made at the factory, although they can be changed in the field.

Although designed primarily for operation with Westinghouse protective relays, this apparatus may also be coordinated with other types of directional-distance relays and with most other contact keyed devices.

SPECIFICATIONS

Frequency Range.....	30-kc to 200-kc
Channel Attenuation Rating	40-db
Transmitter Power Output.....	1.0 watt at standard conditions (see Figs. 12 and 13). 0.5 watt with a 48-volt d-c supply.
Transmitter Harmonic Output	At least 46-db below fundamental.
Transmitter Output Impedance.....	Matches one 60-ohm coax. cable. (Suitable for 50-70 ohm cable.)
Transmitter Output Filter Selectivity	See Fig. 10
Transmitter and Receiver Oscillator and Frequency Stability	From -20°C to +50°C with simultaneous voltage variations from 100 to 140 VDC, the frequency remains with 0.01%.

Permissible Battery Voltage Ripple	7-1/2%
Ambient Temperature Range	-20°C to +50°C.
Non-Operating Temperature Range	-40°C to +70°C
Receiver Sensitivity	0.04 volts at standard conditions (see Figs. 10 and 18).
Receiver Selectivity	See Fig. 14
Receiver Signal-to-Noise Ratio Requirements	12-db
Minimum Channel Spacing	See Fig. 16
Power Input	115-ma at 48 VDC, 200-ma at 125 VDC, 1.28 amperes at 250 VDC.
Carrier On-Off Keying	Requires one pair of contacts capable of keying 8-ma DC at an open circuit voltage of 125 VDC.
Weight (With Flexitest Case)	Approximately 16-lbs.

CAUTION Refer application to Westinghouse when other transmitters are to be connected to the same coax cable as certain conditions may result in damage to the output transistors.

NOTE Standard conditions are taken as 129-volts, 120-kc and 25°C.

or silicon semi-conductor materials. The junction transistor consists of a thin slice of germanium or silicon with three different regions produced by introducing specific amounts of impurities. A thin wire is connected to each region. One outer region is called the emitter, the other the collector, and inserted between them is the base. These correspond roughly to the cathode, plate, and grid of a vacuum tube.

DESCRIPTION

General

This completely transistorized carrier-apparatus is a result of extensive field and laboratory tests. From these tests, it was proven that transistors provide superior reliability over tubes. In addition, the latest printed circuit and filter techniques have improved performance and greatly decreased the size. The expected long life of transistors as compared with vacuum tubes will reduce maintenance costs, and the low power requirements will produce important savings in battery and charger requirements.

Transistors perform the same functions as vacuum tubes. However, tubes operate by the flow of electrons in a vacuum between elements, while transistors depend upon the movement of electrons in a solid. This leads to a more rugged type of construction. Most transistors are made from either germanium

The transistors in this equipment are of the junction type, and both NPN and PNP configurations are used. In the NPN transistor, the majority of the current is carried by electrons. In the PNP transistor there is a deficiency of electrons. These deficiencies are known as "holes". For practical purposes holes may be considered as positively charged "electrons", and these provide most of the current flow in PNP units. In order to obtain maximum efficiency and reliability, both types are used in this equipment.

Silicon transistors are used in the transmitter and receiver output circuit in order to stabilize critical circuit performance at elevated temperatures.

Mechanical

This apparatus is supplied in a Flexitest case and may be either flush or projection mounted in

order to match other switchboard equipment. The outline dimensions and also the drilling plan for flush and projection mounting are shown by Fig. 1. The majority of the parts are mounted on a printed circuit board. This board may be readily removed as follows:

1. Remove the two output plugs from the red and black jacks.
2. Disconnect the receiver input coaxial cable connector.
3. Loosen the two screws at the top of the board.
4. Loosen the two screws at the bottom of the board and pull them out as far as they will extend.
5. Pull board down to disengage the terminals and lift out.

The transmitter output filter may be removed by removing four mounting screws from the bottom of the case and disconnecting the coaxial cable.

Fig. 6. shows the location of major components such as potentiometers, jack, test points, crystals, transistors, etc. External connections and the Schematic Diagram are shown by Fig. 2. The numbered terminals shown as squares apply to the external terminals.

Provisions are made for plugging the Voice Adapter Unit in the rear of the relaying equipment. Octal socket marked X-4 on the rear of the set accommodates the adapter plug. A buckle type strap on each side of the adapter holds the unit in place after it has been plugged in. The normal projection for a rear mounted Voice Adapter is 3-inches beyond that of the relaying equipment. When the KR Relaying Unit is supplied with the adapter, a patch cord is available on separate order. This patch cord plugs into the telephone jacks on the adapter and provides an extension to a conveniently located terminal board.

The panel cutout information necessary for mounting the Sleet Detector is shown by Fig. 11. This unit consists of a potentiometer and pushbutton switch mounted on a small panel, itself suitable for switchboard mounting.

For 250-volt operation, separate auxiliary resistors are required, as shown in Fig. 8.

Electrical

Transmitter

The transmitter is made of four main stages in-

cluding an oscillator, driver, power amplifier, and an output filter. In the oscillator, the crystal is operated as a resonant circuit between the collector of one transistor and the base of the other. The feedback is supplied through a capacitor from the collector of the second transistor to the base of the first transistor. The frequency is independent of voltage or temperature changes of the transistors. Thus the frequency stability is the stability of the crystal.

The input to the driver stage Q-10 is controlled by potentiometer, R-42 which also controls the transmitter power output. In HZM relaying CARRIER STOP provides about +40 volts for blocking. This is applied to Q-10 through T-6. Diode CR-5 prevents damage to the transistor when this positive voltage is applied to the collector. For CARRIER START (when in the blocked position) a small positive voltage is applied to the collector of Q-10 by means of bleeder resistors R-67 and R-68.

The power amplifier consists of two transistors Q-12 and Q-15, which are operated as class B amplifiers in push-pull. Resistors R-52 and R-55 are for stabilization.

The output transformer, T-7, matches coaxial cables of 50 to 70 ohms.

Resistor R-66 tends to keep the source impedance constant to permit proper tuning of the output filter.

The output filter consists of coils L-1 and L-2, capacitors C-19 through C-22. The filter is tunable, and is provided to attenuate harmonics and other spurious outputs. It should be noted that the filter contains no shunt elements, resulting in a reverse impedance free of "across the line" resonances.

Receiver

The receiver is a superheterodyne in order to obtain constant selectivity regardless of the channel frequency. (See Fig. 14.) The major stages include an input filter, attenuator, oscillator, mixer, IF filters, IF amplifiers, detector and a D-C power output stage.

The input filter prevents undesired signals from producing the IF frequency.

The receiver sensitivity is adjusted by means of the continuously variable input control R-1 and by

connecting or disconnecting resistors R-73 and R-74 in the IF stages.

The receiver oscillator (Q-2 and Q-3) is basically the same as the transmitter oscillator. The frequency is 20-kc above the incoming signal frequency.

The receiver channel frequency is determined by the input filter and the oscillator crystal. The frequency may be changed readily since both the filter and the crystal are plug-in components.

Mixing is accomplished by feeding the incoming signal to the emitter and the receiver oscillator signal to the base of the mixer Q-1. Mixer oscillator requirements are met through adjustment of potentiometer R-4. Injection into two separate elements, base and emitter, provides a circuit capable of handling greater signal level variations than one in which injection is made into only a single element such as the base.

This receiver uses an IF frequency of 20-kc. The overall selectivity is determined primarily by the IF filter FL-2. Typical characteristics of this filter are shown in Fig. 15.

The IF amplifier consists of transistors Q-4, Q-5 and Q-6.

The detector is a full wave bridge rectifier. This rectifier in conjunction with the IF amplifier Q-6, provides the necessary power to drive the D-C power output stage Q-7.

The final output stage Q-7 will supply approximately 18 milliamperes to a standard 1700 ohm distance relay RRH coil and its associated 500 ohm alarm coil. It may also be used to drive other relay coils such as is shown by Fig. 7, Supervisory Control Connections.

Transmitter Control Circuits

In the standby condition, although the oscillator is running, the transmitter driver has no emitter bias which results in no output.

Positive voltage applied to terminal 15 supplies this bias through a voltage dividing network, and transmitter output results. The actual configuration of the network is a function of supply voltage and application (Relaying, Telemetering, etc.) and is

discussed in the Adjustments section.

Output may be stopped in several ways. The method used with K-DAR relays is to remove the positive voltage applied to terminal 15. In the case of distance relaying with Westinghouse HZ/HZM relays, application of a positive voltage to terminal 18 will stop the transmitter output. Output may also be stopped by removal of negative battery from terminal 18.

Reserve Signal Detector

The Reserve Signal Detector is shown by Fig. 11. Effectively R-1 is a remote transmitter output control. This control is obtained through varying the driver stage (Q-10) emitter bias, and is effective over a 40-db range of transmitter output. The detector is switched into service by S-1. By adjusting R-1 for a given receiver relay current at the far end of the channel, a relative measure of the channel attenuation may be obtained. This is discussed further in the section on Adjustments.

Communications

The transmitter output is reduced approximately 6-db when the Type KR voice adapter attachment is used. Relaying takes preference, and full output is obtained since full voltage is supplied to terminal 15.

Relaying Control Circuits

Figs. 3, 4 and 5 show simplified diagrams of the relaying control circuits.

1. K-DAR and GCY Relaying (Figs. 4 and 5)

The control of the carrier set is obtained through the CARRIER START and CARRIER STOP contacts. These contacts are shown in their normal standby condition.

The K-DAR or GCY relays operating from the voltage and current on the transmission line, detect and determine the direction of a line fault and thereby control the carrier transmitter and receiver.

The control of the carrier set is such as to start the transmission of carrier when fault power on the transmission line is flowing out of the line section being protected. Conversely, when fault power is flowing into this line section, the control is such as to block the transmitter and keep it from being turned on by secondary functions such as sleet detection

and communication, should these functions be in use at the same time. Should carrier be received from the remote station, the hold coil and alarm coil will energize through transistor Q-7 in the receiver.

When carrier start operation occurs, the CARRIER START contact opens applying a positive voltage (see Figs. 4 and 5) to terminal 15 of the carrier set. This puts a potential on the driver stage in the transmitter and also applies proper bias for the power amplifier.

When a carrier stop operation occurs, the CARRIER STOP contact closes, which removes B+ (terminal 15) from the driver and the power amplifier stages in the transmitter. CARRIER STOP, terminal 18, on the carrier set is permanently connected to terminal 14, for K-DAR and GCY relaying.

2. HZM Relaying (Fig. 3)

The control of the carrier set is effected by the CARRIER START and the CARRIER STOP contacts. These contacts are shown in their normal standby condition.

The HZ-HZM relays operating from the voltage and current on the transmission line, detect and determine the direction of a line fault and thereby control the carrier transmitter and receiver.

The control of the carrier set is such as to start the transmission of carrier when fault power on the transmission line is flowing out of the line section being protected. Conversely, when fault power is flowing into this line section, the control is such as to block the transmitter and keep it from being turned on by secondary functions such as sleet detection and communication, should these functions be in use at the same time. Should carrier now be received from the remote station, the hold coil and alarm coil will energize through transistor Q-7 in the receiver.

When carrier start operation occurs, the CARRIER START contact closes applying the full battery supply voltage to terminal 15 of the carrier set. This puts a potential on the driver stage in the transmitter and also applies proper bias for the power amplifier.

When a carrier stop operation occurs, the CARRIER STOP contact opens. This applies a positive voltage (see Fig. 3) to terminal 18 which blocks the driver stage and the power amplifier stage

It is possible under certain conditions that the signals from two transmitters, attempting to block a third receiver, would be of such amplitude, phase and frequency as to cause the RRH coil current to "pulsate". It would then be possible to have a false trip.

In the case of the KR set for relaying 3-terminal lines, the transmitter frequencies (to avoid this possibility of false trip) should be separated by 100 cycles. All receivers and one transmitter would be for the desired center frequency. One of the other transmitters would be 100 cycles above, the other 100 cycles below this center frequency.

INSTALLATION

General

Upon receipt of a unit, whether shipped separately or in an assembly, an immediate inspection should be made. Carefully check for damage or shortages.

For necessary clearances and mounting dimensions, see the following illustrations:

- Flexitest Case Mounting..... Fig. 1
- Sleet Detector..... Fig. 11

Connections

External

The external connections will vary slightly depending on the application, but in general will be along the lines described as follows: (Refer to the Schematic Diagram, Fig. 2.)

- Terminals 11..... Ground
- 12..... Coaxial Cable
- 13 and 19 Supervisory Preference Contacts
- 14..... B- "CARRIER STOP" return
- 15..... Battery positive through carrier start contacts
- 16..... Battery positive for alarm cutoff (used with communication)
- 17..... B-
- 18..... Carrier Stop for HZM Relaying
- 19..... B+
- 20..... Relay Coil

CAUTION If the transmitter output load is removed while the transmitter is energized, the transistors in

the power amplifier will be permanently damaged. A dummy load should be connected to the transmitter output if the coax is disconnected and the transmitter is to be energized.

When tuning line coupling equipment, short the coaxial cable to ground before changing taps on the Line Tuner or matching transformer.

Internal

Necessary internal connections are generally made at the factory, to customer order, before apparatus shipment. For reference purposes, these are outlined in the following tabulation. Check the proper bleeder resistors before applying voltage to the equipment.

OPERATION	BLEEDER RESISTORS IN THE CIRCUIT
48-Volt K-DAR, HZM, and GCY Relaying, Telemetering, and Supervisory	R-47 and R-48
125-Volt K-DAR and GCY Relaying	R-45, R-47 and R-48
125-Volt HZM Relaying, Telemetering, and Supervisory	R-41, R-45, R-47 and R-48
250-Volt K-DAR and GCY Relaying	R-45, R-47 and R-48
250-Volt HZM Relaying, Telemetering, and Supervisory	R-39, R-40, R-41, R-45, R-47 and R-48

Various combinations of the inductors and capacitors of the transmitter output filter are required depending on the channel frequency. These are tabulated in Fig. 9.

Adjustments

This apparatus is generally tuned to and tested at the specified channel frequency before shipment. Final adjustments must be made in the field and are described in the following paragraphs. Fig. 6 shows the locations of the various controls.

Transmitter

1. Disconnect the coaxial cable and replace with a 50, 60, or 70 ohm non-inductive resistor depending on the characteristic impedance of the cable used.

2. Fig. 9 shows typical output filter connections for various frequency ranges. In some cases it may be necessary to use either a higher or lower range to tune the filter to resonance.

3. Insert fuses F-1 and F-2 to apply power to the apparatus.

4. Connect an A-C Vacuum Tube Voltmeter (VTVM) across the non-inductive load.

5. Unblock the transmitter by closing the CARRIER TEST SWITCH. An alternative is to jumper battery positive to terminal 15.

6. Beginning with the output control R-42 at the maximum counterclockwise position, advance it clockwise until a reading appears on the VTVM. Tune capacitor C-19 for a maximum voltmeter reading.

7. While increasing R-42, tune the output filter for maximum output until the output across the resistor is approximately 8 volts. (See Figs. 12 and 13.) (Approximately 5.5 volts when operating from 51-volt station battery.)

8. Open the test switch and reconnect the coaxial cable.

Receiver

1. The oscillator output control R-4 is pre-set at the factory. However, should any of the oscillator components be changed (including the transistors and the crystal) R-4 will require adjustment.

a. Connect an A-C VTVM to jacks J-3 and J-4.

b. Adjust R-4 for a 0.3 volt reading on the meter.

2. The unit is shipped to have a gain of approxi-

mately 250 millivolts (to produce 10 ma relay current) with input control R-1 in maximum clockwise position. About 10-db additional gain or 80 millivolt sensitivity can be obtained by clipping out resistor R-74, which is connected to the base of Q-4 and the B+ supply for the IF. Approximately 10-db gain or 25 millivolt sensitivity can be obtained by clipping out resistor R-73, which is connected to the base of Q-5 and the B+ supply for the IF. Resistor R-71 has been selected at the factory to provide an overall gain of approximately 25 millivolts.

a. Sensitivity Adjustment for Noise

If the maximum on-frequency noise level is known or can be measured, the receiver can be adjusted for this level. Disconnect the coaxial cable and connect a 60-ohm non-inductive resistor and a VTVM across terminals 11 and 12. Energize the transmitter and output control R-42 for the same output as the maximum noise. Then adjust the receiver input control R-1 to obtain 1-ma output current. If it is impossible to obtain 1-ma output current with control R-1 in the maximum clockwise position, then clip out resistor R-74, which is connected to the base of Q-4. If the gain is still insufficient, clip out resistor R-73, which is connected to the base of Q-5. After completing the adjustment of R-1, restore the transmitter to full output.

b. Sensitivity Adjustment for Remote Signal

When the maximum on-frequency noise is unknown and cannot be conveniently measured, the receiver may be adjusted for the remote signal. First determine the channel attenuation using a Sierra voltmeter or some other convenient method. Disconnect the coaxial cable and connect a 60-ohm non-inductive resistor and a VTVM across terminals 11 and 12. Add 15-db to the channel attenuation. This compensates for average variations such as channel and voltage variations. For example, if the channel attenuation is 5-db, add this to the 15-db making a total of 20-db. Taking this from 8 volts output of the transmitter, the receiver should then be set for a sensitivity of 0.8 volts. To do this, adjust the transmitter output control R-42 for 0.8 volts and then adjust the receiver input control so as to obtain 10-ma output current. If it is impossible to obtain 10-ma output current with control R-1 in the maximum clockwise position, clip out resistor R-74, which is connected to the base of Q-4. If the gain is still insufficient, clip out resistor R-73, which is connected to the base of Q-5. After completing the

adjustment of R-1, restore the transmitter to full output.

It must be kept in mind that the two preceding adjustment procedures are to be used as a guide and will cover the majority of cases; however, cases may arise where conditions change. For example, if the adjustment is made per part a., the noise may increase due to various reasons such as bad insulators, which would require adjusting the receiver to be less sensitive. In the adjustment of part b., the attenuation may increase due to sleet or line switching, which would necessitate increasing the sensitivity of the receiver.

Reserve Signal Detector

Due to different types of operation and supply voltages, it is not practical to have a calibrated dial for this unit. However, calibration may be made at installation by recording transmitter output (either in db or volts) at various knob settings of the detector unit. Then, by adjusting the knob so as to obtain 10 milliamperes relay current at a remote receiver, any increase or decrease in line attenuation may be noted as the difference between the original setting, and the setting required to obtain the given 10 milliamperes.

250-Volt Resistor Unit

With the apparatus energized, adjust R-4 in the 250-volt resistor unit so as to obtain 125-volts at terminals 17 (B-) and 19 (B+) on the relaying set.

Frequency Change

If the frequency is changed in the field, it is necessary to change the input filter FL-1 to the desired channel frequency. This filter is of the plug-in type and may be removed by unsnapping the clamp and pulling the filter out. The transmitter oscillator crystal Y-2 must be changed to the desired channel frequency. The receiver oscillator crystal Y-1 must be changed to the desired channel frequency plus 20 kc. Figure 9 shows the connections for the transmitter output filter. It is necessary to unsolder the existing connections and make the new connections per the chart. After completing the preceding, the tuning procedure as described under Adjustments for transmitter and receiver should then be followed.

Note also that capacitors C2 and C9 in the transmitter and receiver crystal oscillator circuits, respectively, may have to be changed. For fre-

quencies below 110 kc, these capacitors are 270 mmf. each. For frequencies of 110 kc and above, the capacitors are 140 mmf. each.

CAUTION Turn power OFF before removing filters or transistors, as high transient currents may cause permanent damage to the transistors.

MAINTENANCE

Voltage values should be recorded after adjustment in order to establish reference values which will be useful when checking the apparatus. The readings will remain fairly constant over an indefinite period unless a failure occurs. However, if transistors are changed, there may be considerable difference in these readings without the overall performance being affected.

Typical voltage and current values are given as follows. Voltages should be measured with VTVM. Readings may vary as much as $\pm 20\%$.

In the following paragraphs, the transmitter may be unblocked (transmitting) by closing the CARRIER START circuit in the case of HZM relaying, and by opening the CARRIER START circuit in the case of K-DAR and GCY relaying.

1. For D-C pin jack measurements with reference to B-, refer to Table 1.

2. For transistor D-C measurements with reference to B-, refer to Table 2.

3. For D-C bleeder measurements with reference to B-, refer to Table 3.

4. For typical RF signal measurements for receiver, refer to Table 4.

5. For typical RF signal measurements for transmitter, refer to Table 5.

6. Removal of Printed Circuit Board from Flexitest Case.

To remove the printed circuit board, unplug J-15 and J-16 located near the output filter. Loosen the two screws inside the case near the top. Loosen the slotted thumb screws at the lower end of the board and pull these screws out as far as they will extend. Also remove the receiver coaxial cable plug.

Pull board down so as to disengage the terminals, and lift out.

7. Removal of the Output Filter

After the printed board has been removed, remove the screws on the outside of the case at the bottom. Lift out filter and disconnect the coaxial cable.

8. Receiver Filters

Fig. 15 shows typical receiver selectivity curves both RF and IF. If the filters are checked in a test setup, it is necessary to use an accurate signal generator or preferably a signal generator and a frequency counter.

9. Minimum Test Equipment for Installation

a. Milliammeter 0-25 ma DC.

b. 60-ohm 5-watt non-inductive resistor.

c. A-C Vacuum Tube Voltmeter (VTVM). Voltage range 0.003 to 30 volts, frequency range 60 cycles/sec to 230-kc, input impedance 7.5 megohms.

d. D-C Vacuum Tube Voltmeter (VTVM)

Voltage Range: 0.15 to 300 volts

Input Impedance: 7.5 megohms

10. Desirable Test Equipment for Apparatus Maintenance

a. All items listed in Sections 8 and 9.

b. Signal Generator

Output Voltage: up to 8 volts

Frequency Range: 20-kc to 230-kc

c. Oscilloscope

d. Ohmmeter

e. Capacitor checker

f. Test harness (See Fig. 17)

TABLE 1

D-C PIN JACK MEASUREMENTS WITH REFERENCE TO B-

Description	Jack	CONDITION A Tx-Blocked †† Rx-No Signal		CONDITION B Tx-Blocked Rx-With Signal		CONDITION C Tx-Unblocked Rx-No Signal	
		129 VDC	51 VDC	129 VDC	51 VDC	129 VDC	51 VDC
RF Input	J-2	0	0	0.3 V	0.3 V		
DC Q-1 Base	J-3	20 V	20 V	20 V	20 V		
DC R _x B+	J-4	20 V	20 V	20 V	20 V		
DC R _x Osc	J-5	7 V	7 V	7 V	7 V		
DC Q-5 Base	J-6	20 V	20 V	20 V	20 V		
B-	J-7						
DC-P1-E	J-8	110 V	32 V	110 V	32 V	110 V	32 V
DC-Q-7 Base	J-9	69 V	0 V	78 V	2.3 V	66 V	0.3 V
DC Q-7 Emit	J-10	70 V	1.0 V	78 V	1.4 V	66 V	1.0 V
DC T _x Osc	J-11	7 V	7 V	7 V	7 V	7 V	7 V
B+	J-12	129 V	51 V	129 V	51 V	129 V	51 V
DC Q-10 Base	J-13					18 V	18 V
DC Q-10 Emit	J-14					18 V	18 V
RF ma out	J-15					130 ma	130 ma
DC ma RRH and ALARM				18 ma	* 18 ma		

†† Tx = transmitter, Rx = receiver

TABLE 2

TYPICAL TRANSISTOR DC MEASUREMENTS WITH REFERENCE TO B-

Transistor	Condition A Tx-Blocked Rx-No Signal (Volts)			Condition B Tx-Blocked Rx-With Signal (Volts)			Condition C Tx-Unblocked Rx-No Signal (Volts)		
	E†	B†	C†	E†	B†	C†	E†	B†	C†
Q-1	20.0	20.0	0.38	20.0	20.0	0.4			
Q-2	7	7.2	1.8	7	7.2	1.8			
Q-3	6.2	8.0	2	6.2	8	2.0			
Q-4	20.0	20.0	2.6	20.0	20.0	2.8			
Q-5	20.0	20.0	2.6	20.0	20.0	2.8			
Q-6									
129 VDC	110	110	129	115	114	129			
51 VDC	32	32	51	32	32	51			
Q-7									
129 VDC	70	68	129	78	80	86			
51 VDC	1.0	0	51	1.4	2.2	7.0			
Q-8	6.2	8	2	6.2	8	2	6.2	8	2
Q-9	7	7.2	1.8	7	7.2	1.8	7	7.2	1.8
Q-10††							18	18	0.4
Q-12††							0.27	0.20	50
Q-15††							0.27	0.20	50

† E-Emitter; B-Base; C-Collector.

†† With respect to term F' on printed board.

TABLE 3

D-C BLEEDER MEASUREMENTS WITH REFERENCE TO B-

Measurement	129 VDC			51 VDC		
	A†	B†	C†	A†	B†	C†
Junction R-61 and R-62 (J-8)	110V	110V	110V	32V	32V	32V
Junction R-61 and R-27 (J-10)	70V	78V	66V	1.0V	1.4V	1.0V
Junction R-27 and R-60 (P1-P)	69V	77V	65V	0	0	0
Junction CR-8 and R-64 (P1-K)	58V	58V	58V	51V	51V	51V
Junction R-48 and R-47 (J-14)	—	—	18V	—	—	18V
Junction R-45 and R-47 (TP-9)	—	—	45V	—	—	51V
Junction R-45 and R-41 (TP-8)	—	—	98V	—	—	51V

†Conditions: A — Tx-Blocked, Rx-No Signal; B — Tx-Blocked, Rx-With Signal; C — Tx-Unblocked, Rx-No Signal.

TABLE 4
TYPICAL RF SIGNAL MEASUREMENTS FOR RECEIVER
(Made with 0.1 Volt at Terminal 5 of FL1)

Check Point	25 MV Sensitivity (Volts)	80 MV Sensitivity (Volts)	250 MV Sensitivity (Volts)
With Receiver Crystal Out			
FL1-5 to Gnd.	0.1	0.1	0.1
T1-1 to Gnd.	0.1	0.1	0.1
Q1-E to Gnd.	0.05	0.05	0.05
Q1-C to Gnd.	0.07	0.07	0.07
T3-1 to Gnd.	0.07	0.07	0.07
Q4-C to Gnd.	0.07	0.07	0.07
With Receiver Crystal In			
Q4-C to Gnd.	0.5	0.5	0.25
J6 to Gnd.	0.15	0.1	0.08
Q5-C to Gnd.	7.0	1.7	0.8
Q6-B to Gnd.	2.0	0.5	0.4
Q6-C to Gnd.	13.0	10.0	8.0
T4-1 to Gnd.	13.0	10.0	8.0
T4-3 to T4-4	4.5	3.5	2.5
J9 to J10 (DC)	0.74	0.75	0.65

TABLE 5

TYPICAL RF SIGNAL MEASUREMENTS FOR TRANSMITTER	
CHECK POINT	VOLTS
T5-1 to Gnd.	5.5
T5-3 to Gnd.	1.0
J13 to Gnd.	0.085
Q10-C to Gnd.	6.0
T6-2 to Gnd.	6.0
Q12-B to Gnd.	0.8
Q15-B to Gnd.	0.8
Q12-C to Gnd.	38.0
Q15-C to Gnd.	38.0
T7-5 to Gnd.	9.8
Output to Gnd.	8.0

APPLICATION

1. Receiver Selectivity (Fig. 14)

This shows a typical curve of the overall selectivity of the receiver under steady state conditions.

2. Transmitter Output Selectivity (Fig. 10)

Typical curves are shown so that approximate bandwidths for keying purposes can be determined for any carrier frequency between 30-kc and 200-kc.

3. Minimum Channel Spacing (Fig.16)

This is a graph from which minimum channel spacing can be obtained provided the signal strength of the interfering transmitter and the sensitivity setting of the receiver are known. These can be obtained from calculations or by measurements.

For example, if the interfering transmitter voltage is measured (at the receiver) and found to be 2.5

volts, this would be 10-db down from 8 volts. This point can be located on the right hand column of the graph. Then, if the receiver sensitivity were set to operate on 0.8 volts or 20-db, this point would be located on the left hand column. A line could then be drawn through the two points as shown by the dotted line. The intersection of this line with the center line indicates the minimum channel spacing. In this case if the interfering signal is being keyed on-off, at 15 pps, the minimum spacing would be 2.5-kc.

4. Transmitter Output and Receiver Sensitivity Variations with Voltage (Fig. 12)

These curves show the variation of transmitter output and receiver sensitivity with changes in supply voltage, at 120-kc and 25°C. The increase and decrease in transmitter output above or below 1.0 watts may be obtained in db from the transmitter curve. 1.0 watts is about 8.0 volts with a 60-ohm load.

The increase and decrease in receiver sensitivity above or below 40 millivolts can similarly be

TYPE KR CARRIER SET

obtained in db from the receiver curve. 40 millivolts sensitivity represents the input signal required for proper operation.

5. Transmitter Output and Receiver Sensitivity Variations with Frequency (Fig. 13)

These curves show the variation of transmitter output and receiver sensitivity with variation in frequency, at a supply voltage of 129 VDC, and 25°C. They may be used in the same manner as Fig. 12.

6. Supervisory Control Connections (Fig. 7)

When supervisory control is used with relaying, the supervisory control relay coil is connected in

series with the RRH coil in place of the alarm relay. When supervisory control is used alone, a 1200-ohm resistor R3 is connected in series with the control relay coil by removing the jumper across R3, as shown in Fig. 7. In order to maintain proper mark space ratio, the relay bias current is adjusted for 9 milliamperes as indicated.

The receiver RF filter and the IF filter limits are shown on Fig. 15. Both filters are of the plug-in type and the test circuits with pin connections are shown at the top of each curve. The IF filter is divided into two separate sections. The selectivity shown is for each section, and the pin connections for each section are also shown in the test circuit sketch.

ELECTRICAL PARTS LIST

CIRCUIT SYMBOL	FUNCTION	DESCRIPTION	MANUFACTURER'S DESIGNATION
<u>CAPACITORS</u>			
C-1	Rcvr. Bleeder	2.0 μ f, \pm 20%, 200 VDC, Paper	330C567 H11
†C-2	Rcvr. Osc. Feedback	140/270 μ f, \pm 20%, 500 VDC, Mica	330C566 H43 or 330C566 H57
C-3	Rcvr. Osc. Bleeder Bypass	0.02 μ f, MRC, 600 VDC, Disc	330C569 H47
C-5	Q-6 Emitter Bypass	1.0 μ f, \pm 20%, 200 VDC Paper	330C567 H09
C-6	Rcvr. Rectifier Bypass	Same as C-5	
C-7	B- to B+ Bypass	2 μ f, \pm 10%, 600 VDC, Paper	14C9400 H18
C-8	B- to GND	1.0 μ f, \pm 10%, 1000 VDC, Paper	14C9400 H17
†C-9	Xmtr. Osc. Feedback	Same as C-2	
C-10	Xmtr. Osc.	Same as C-3	
C-11	Key Filter	0.1 μ f, \pm 20%, 200 VDC, Paper	330C567 H02
C-12	Q-10 Emitter Bypass	0.25 μ f, \pm 20%, 200 VDC, Paper	330C567 H05
C-13	Q-10 Bleeder Bypass	Same as C-12	
C-14	PA Base Bypass	Same as C-12	

†Note: 140 μ f for osc. freq. 110-kc and above.
270 μ f for osc. freq. below 110-kc.

ELECTRICAL PARTS LIST

CIRCUIT SYMBOL	FUNCTION	DESCRIPTION	MANUFACTURER'S DESIGNATION
<u>CAPACITORS (Concluded)</u>			
C-18	PA Bleeder	0.5 μ f, \pm 20%, Paper	330C567 H06
C-19	Output Filter Tuning	500 μ f, Variable, Air	328C092 H01
C-20	Output Filter	390 μ f, \pm 5%, 2500 VDC, Mica	330C561 H15
C-21	Output Filter	680 μ f, \pm 5%, 2500 VDC, Mica	330C561 H21
C-22	Output Filter	1200 μ f, \pm 5%, 2500 VDC, Mica	330C561 H27
C-24	FL-2 Decoupling	Same as C-12	
C-25	Q-7 Emitter	12 mfd, \pm 20%, 200 VDC	187A177 H01
<u>CRYSTAL DIODES</u>			
CR-1	Bridge Rectifier	General Purpose, 1N63 *	584C433 H02
CR-2	Bridge Rectifier	Same as CR-1	
CR-3	Bridge Rectifier	Same as CR-1	
CR-4	Bridge Rectifier	Same as CR-1	
CR-5	Q-10 Collector	Same as CR-1	
CR-6	Q-7 Base-Emitter	*Type 1N457A	184A855H07 *
CR-7	Voltage Regulator	Type 1N768,	584C434 H02
CR-8	Voltage Regulator	Type 1N1369	584C434 H05
CR-9	Q-7 Collector	*Type 1N3811	185A089H08
CR-10 *	Q10 Emitter *	Type 1N3028A *	188A302H14 *

ELECTRICAL PARTS LIST

CIRCUIT SYMBOL	FUNCTION	DESCRIPTION	MANUFACTURER'S DESIGNATION
<u>FUSE HOLDERS</u>			
FH-1	B-	For Type 3AGC Fuses	584C271 H02
FH-2	B+	Same as FH-1	
<u>FUSES</u>			
F-1	B-	3AGC 3/4 amp.	S#330C691 H12
F-2	B+	Same as F-1	
<u>FILTERS</u>			
FL-1	Rcvr. RF Bandpass	30 to 200 kc Freq. to be specified by customer	
FL-2	Rcvr. IF Bandpass	20-kc Fixed Freq.	
<u>CONNECTORS</u>			
J-1	Printed Circuit	Printed Circuit Female Plug	54-B-7125 H03
J-2	RF Input	UG-185-U	584C292 H07
J-3	Rcvr. Osc. Output	Terminal Studs	330C592 H01
J-4	Rcvr. Mixer-Amp Supply	Same as J-3	
J-5	Rcvr. Osc. Supply	Same as J-3	
J-6	Q-5 Base	Same as J-3	
J-7	B-	Same as J-3	
J-8	Q-6 Supply	Same as J-3	

ELECTRICAL PARTS LIST

CIRCUIT SYMBOL	FUNCTION	DESCRIPTION	MANUFACTURER'S DESIGNATION
<u>CONNECTORS (Concluded)</u>			
J-9	Q-7 Base	Same as J-3	
J-10	Q-7 Emitter	Same as J-3	
J-11	Xmtr. Osc. Supply	Same as J-3	
J-12	B+	Same as J-3	
J-13	Xmtr. Osc. Output	Same as J-3	
J-14	Q-10 Supply	Same as J-3	
J-15	Output Filter	Banana Tip Red	328C093 H01
J-16	Output Filter GND	Banana Tip Black	328C093 H02
P-1	Printed Circuit	Printed Circuit Male Plug	54-B-7126 H03
<u>INDUCTORS</u>			
L-1	Core and Coil Assembly	11 MH Total – 6 MH Tap (Part of FL-3)	329C450
L-2	Core and Coil Assembly	2.5 MH (Part of FL-3)	329C449
L-3	RF Choke	1.0 MH, 300 ma	R-300
L-4	RF Choke	Same as L-3	
<u>TRANSISTORS</u>			
Q-1	Rcvr. Mixer	Type 2N525	184A638H13
Q-2	Rcvr. Osc.	Type 2N414	184A638H14

ELECTRICAL PARTS LIST

CIRCUIT SYMBOL	FUNCTION	DESCRIPTION	MANUFACTURER'S DESIGNATION
<u>TRANSISTORS (Concluded)</u>			
Q-3	Rcvr. Osc.	Same as Q-2	
Q-4	Rcvr. IF	Same as Q-1	
Q-5	Rcvr. IF	Same as Q-1	
Q-6	Rcvr. IF	Type 2N498 or * Type 2N657	184A638H15 * 184A638H15
Q-7	Rcvr. Output	Type 2N698	762A585H02
Q-8	Xmtr. Osc.	Same as Q-2	
Q-9	Xmtr. Osc.	Same as Q-2	
Q-10	Xmtr. Amp.	Same as Q-1	
Q-12	Xmtr. PA	* Type 2N498 or Type 2N657	* 184A638H07 184A638H15
Q-15	Xmtr. PA	Same as Q-12	
<u>RESISTORS</u>			
R-1	Rec. Input	25 K, $\pm 20\%$, 1/4 W, Pot.	584C276 H23
R-2	Filter Matching	10 K, $\pm 10\%$, 1/2 W	330C595 H37
R-3	Filter Load	Same as R-2	
R-4	Rcvr. Osc.	1 K, $\pm 20\%$, 1/4 W, Pot.	584C276 H19
R-5	Rcvr. Voltage Divider	6.2 K, $\pm 5\%$, 1 W	330C666 H68
R-6	Q-2 Collector	1.2 K, $\pm 5\%$, 1/2 W	330C664 H51
R-8	Rcvr. Voltage Divider	30 K, $\pm 5\%$, 2 W	330C668 H84
R-9	Rcvr. Voltage Divider	Same as R-8	

ELECTRICAL PARTS LIST

CIRCUIT SYMBOL	FUNCTION	DESCRIPTION	MANUFACTURER'S DESIGNATION
		<u>RESISTORS (Continued)</u>	
R-10	Q-2 Base	Same as R-2	
R-11	Q-2 Base	100 K, $\pm 5\%$, 1/2 W	330C665 H05
R-12	Q-3 Collector	Same as R-6	
R-13	Q-3 Emitter	390 Ohms, $\pm 5\%$, 1/2 W	330C664 H39
R-14	Q-3 Base	Same as R-2	
R-15	Q-3 Base	Same as R-11	
R-16	Rcvr. Osc. Bleeder	2.2 K, $\pm 10\%$, 1/2 W	330C595 H41
R-17	Rcvr. Osc. Bleeder	18 K, $\pm 10\%$, 2 W	330C597 H40
R-18	Rcvr. Osc.	9.1 K, $\pm 5\%$, 1/2 W	330C664 H72
R-19	Q-4 Bias	100 Ohms, $\pm 5\%$, 1/2 W	330C664 H25
R-20	Q-4 Bias	Same as R-2	
R-21	Q-5 Bias	150 Ohms, $\pm 5\%$, 1/2 W	330C664 H29
R-22	Q-5 Bias	Same as R-2	
R-23	Q-6 Bias	330 Ohms, $\pm 5\%$, 1/2 W	330C664 H37
R-24	Q-6 Bias	Same as R-2	
R-25	Q-6 Emitter	Same as R-19	
R-26	Q-7 Base	Same as R-6	
R-27	Q-7 Bias	20 Ohms, $\pm 5\%$, 1/2 W	330C664 H08
R-28	Xmtr. Osc. Bleeder	Same as R-18	
R-29	Xmtr. Osc. Bleeder	Same as R-17	
R-30	Xmtr. Osc. Bleeder	Same as R-16	

ELECTRICAL PARTS LIST

CIRCUIT SYMBOL	FUNCTION	DESCRIPTION	MANUFACTURER'S DESIGNATION
		<u>RESISTORS (Continued)</u>	
R-31	Q-8 Base	Same as R-11	
R-32	Q-8 Base	Same as R-2	
R-33	Q-8 Emitter	Same as R-13	
R-34	Q-8 Collector	Same as R-6	
R-35	Q-9 Base	Same as R-11	
R-36	Q-9 Base	Same as R-2	
R-37	Q-9 Collector	Same as R-6	
R-38	Key Filter	Same as R-23	
R-39	Buffer Voltage Divider	36 K, $\pm 5\%$, 2 W	330C668 H86
R-40	Buffer Voltage Divider	Same as R-39	
R-41	Buffer Voltage Divider	Same as R-2	
R-42	Xmtr. Osc. Output	Same as R-4	
R-43	Q-10 Bias	Same as R-23	
R-44	Q-10 Bias	33 K, $\pm 5\%$, 1/2 W	330C664 H85
R-45	Buffer Voltage Divider	15 K, $\pm 10\%$, 1 W	330C596 H39
R-47	Buffer Voltage Divider	6.8 K, $\pm 5\%$, 1/2 W	330C664 H69
R-48	Buffer Voltage Divider	15 K, $\pm 5\%$, 1/2 W	330C664 H77
R-49	PA Bias	27 K, $\pm 5\%$, 2 W	330C668 H83

ELECTRICAL PARTS LIST

CIRCUIT SYMBOL	FUNCTION	DESCRIPTION	MANUFACTURER'S DESIGNATION
		<u>RESISTORS (Concluded)</u>	
R-50	Xmtr. PA	Same as R-19	
R-52	Q-12 Emitter	10 Ohms, $\pm 5\%$, 1/2 W	330C664 H01
R-55	Q-15 Emitter	Same as R-52	
R-59	Xmtr. Bleeder	47 Ohms, $\pm 10\%$, 1/2 W	330C595 H09
R-60	Recvr. Bleeder	1 K, $\pm 5\%$, 25 W	584C416 H57
R-61	Recvr. Bleeder	600 Ohms, $\pm 5\%$, 25 W	584C416 H47
R-62	Recvr. Bleeder	350 Ohms, $\pm 5\%$, 25 W	584C416 H52
R-64	Xmtr. Bleeder	1200 Ohms, $\pm 5\%$, 25 W	584C416 H64
R-66	T-7 Load	560 Ohms, $\pm 5\%$, 2 W	330C668 H43
R-67	Xmtr. Blocking	10 Ohms, $\pm 5\%$, 2 W	330C668 H01
R-68	Xmtr. Blocking	10 K, $\pm 10\%$, 10 W	330C577 H01
R-69	Q-10 Emitter	Same as R-19	
R-70	FL2 Decoupling	470 Ohms, $\pm 10\%$, 1/2 W	330C595 H21
R-71	Q-4 Emitter	150 Ohms, $\pm 10\%$, 1/2 W	330C595 H15
R-72	Q-5 Emitter	68 Ohms, $\pm 10\%$, 1/2 W	330C595 H11
R-73	Q-5 Base	180 Ohms, $\pm 10\%$, 1/2 W	330C595 H16
R-74	Q-4 Base	2.7 K, $\pm 5\%$, 1/2 W	330C664 H59
R-75	Q-4 Collector	22 K, $\pm 10\%$, 1/2 W	330C595 H41
R-76	Q-5 Collector	Same as R-75	

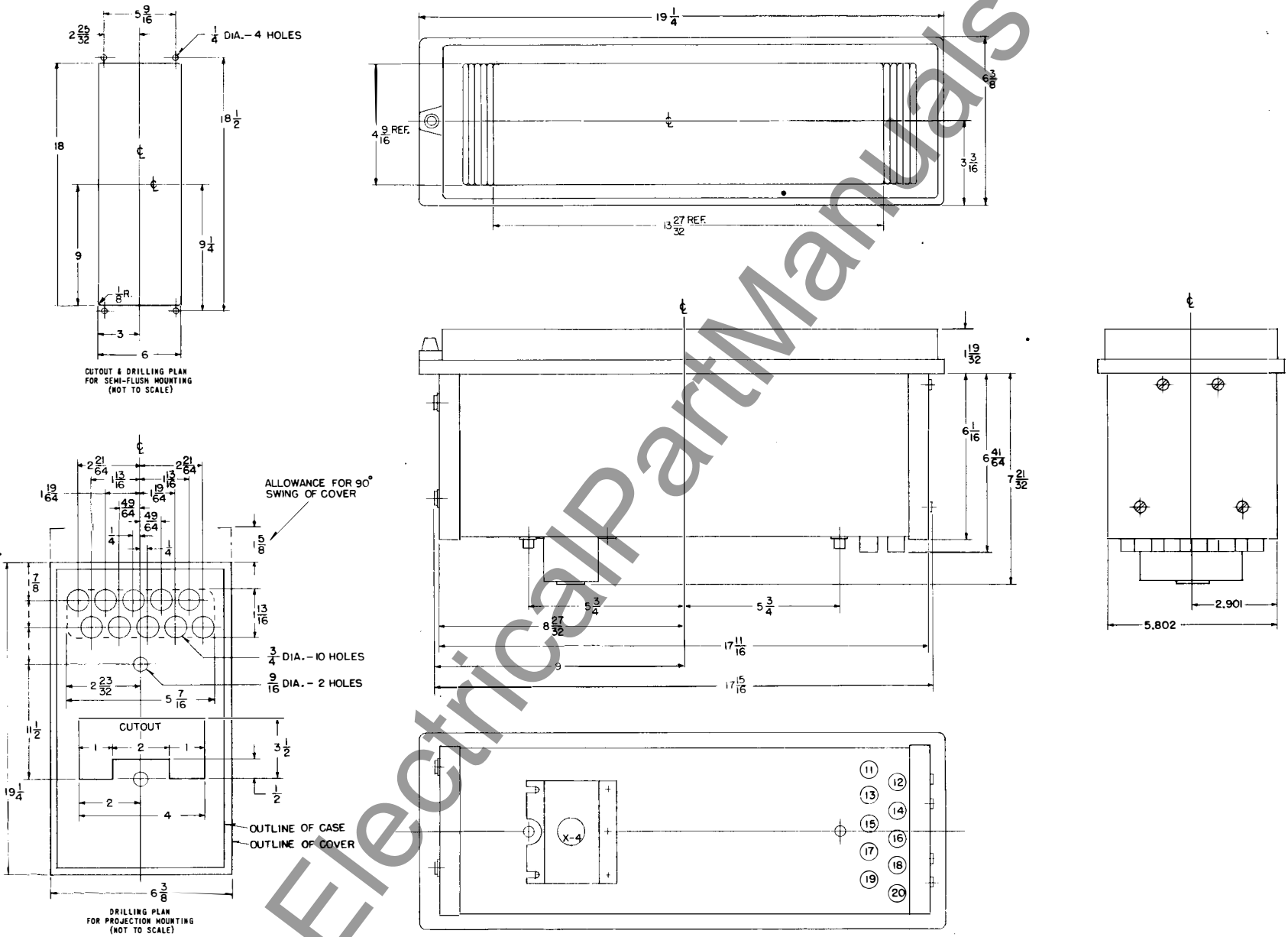
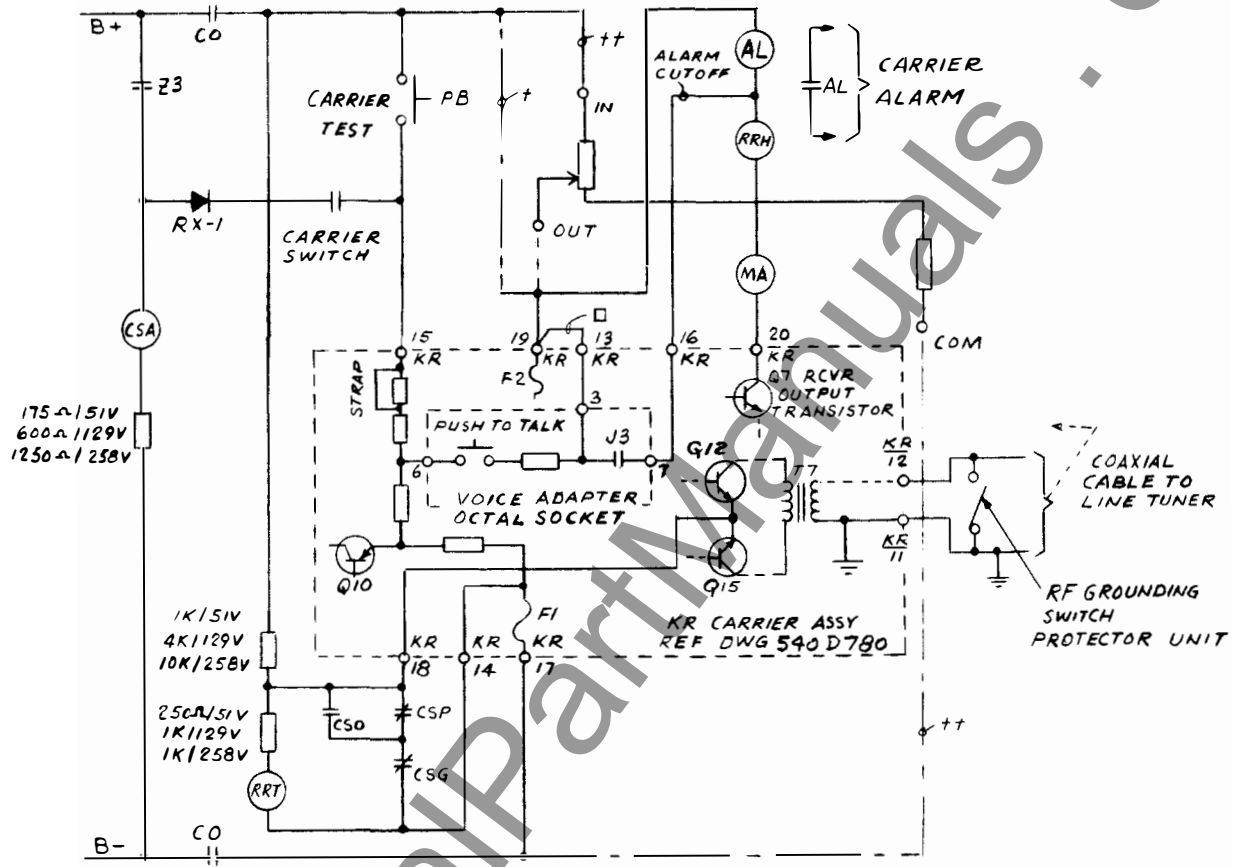

Fig. 1 Outline Drawing, (Flexitest Case) (540753)

TYPE KR CARRIER SET



REQUIREMENTS FOR HZ/HZM RELAYING

SUPPLY VOLTAGE	CARRIER START	CARRIER STOP	STRAP
5VDC	+5V, 7MA	+28V	IN
129VDC	+129V, 8MA	+40V	IN
258VDC	+258V, 8MA	+40V	OUT

KR RELAYING TRANSMITTER /
RECV. EXTERNAL CONNECTIONS

TERMINAL CONNECTION

- 11 GROUND
- 12 COAXIAL CABLE
- 13 SUPERVISORY PREFERENCE CONTACT
- 14 CARRIER STOP B- RETURN
- 15 CARRIER START (POSITIVE)
- 16 ALARM CUTOFF FOR COMMUNICATIONS
- 17 B MINUS
- 18 CARRIER STOP (HZ/HZM)
- 19 B PLUS
- 20 RELAY COIL

NOTES

- + FOR 51 & 129 VDC SUPPLY.
- ++ FOR 258 VDC SUPPLY USE 330C191H01 RESISTOR UNIT REF DWG 223B497
- FOR SUPERVISORY CONTROL PREFERENCE CONTACTS.

* Fig. 3- Relaying Control Circuits - HZ/HZM (Dwg. 1-329C704)

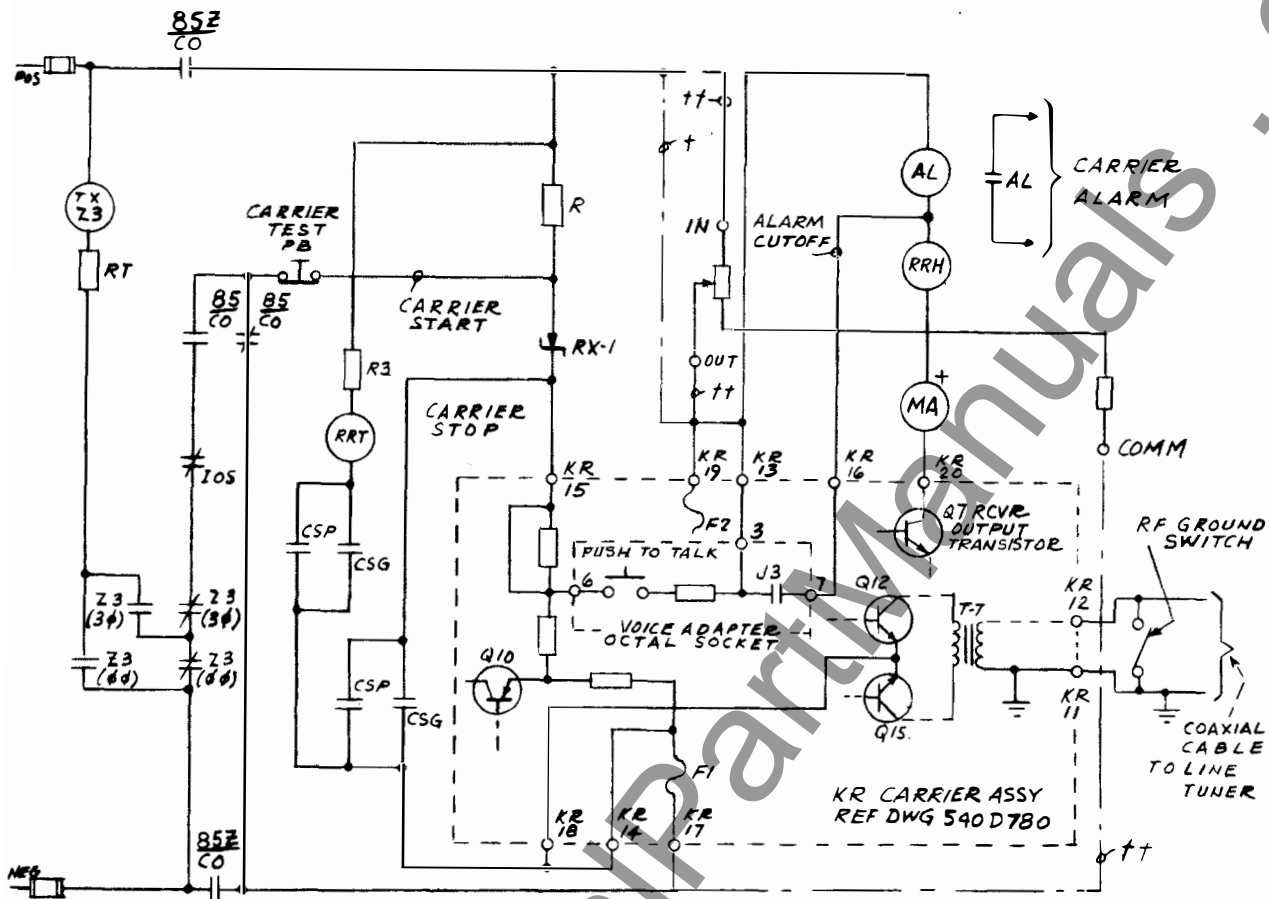

REQUIREMENTS FOR K-DAR RELAYING

SUPPLY VOLTAGE	CARRIER START	CARRIER STOP	R
51 VDC	+ 37V, 7MA	0 VOLTS	2K
129 VDC	+100V 8MA	0 VOLTS	3.75K
258 VDC	+100V 8MA	0 VOLTS	19K

NOTES

KR RELAYING TRANSMITTER /
RECV. EXTERNAL CONNECTIONS

TERMINAL CONNECTION

- 11 GROUND
- 12 COAXIAL CABLE
- 13 SUPERVISORY PREFERENCE CONTACT
- 14 CARRIER STOP B- RETURN
- 15 CARRIER START (POSITIVE)
- 16 ALARM CUTOFF FOR COMMUNICATIONS
- 17 B MINUS
- 18 CARRIER STOP (HZ/HZM)
- 19 B PLUS
- 20 RELAY COIL

- † FOR 51 & 129 VDC SUPPLY
- †† FOR 258VDC SUPPLY USE
330C191H01 RESISTOR UNIT
REF DWG 223B497

* Fig. 4-Relaying Control Circuits-K-Dar (Dwg. 3-329C704)

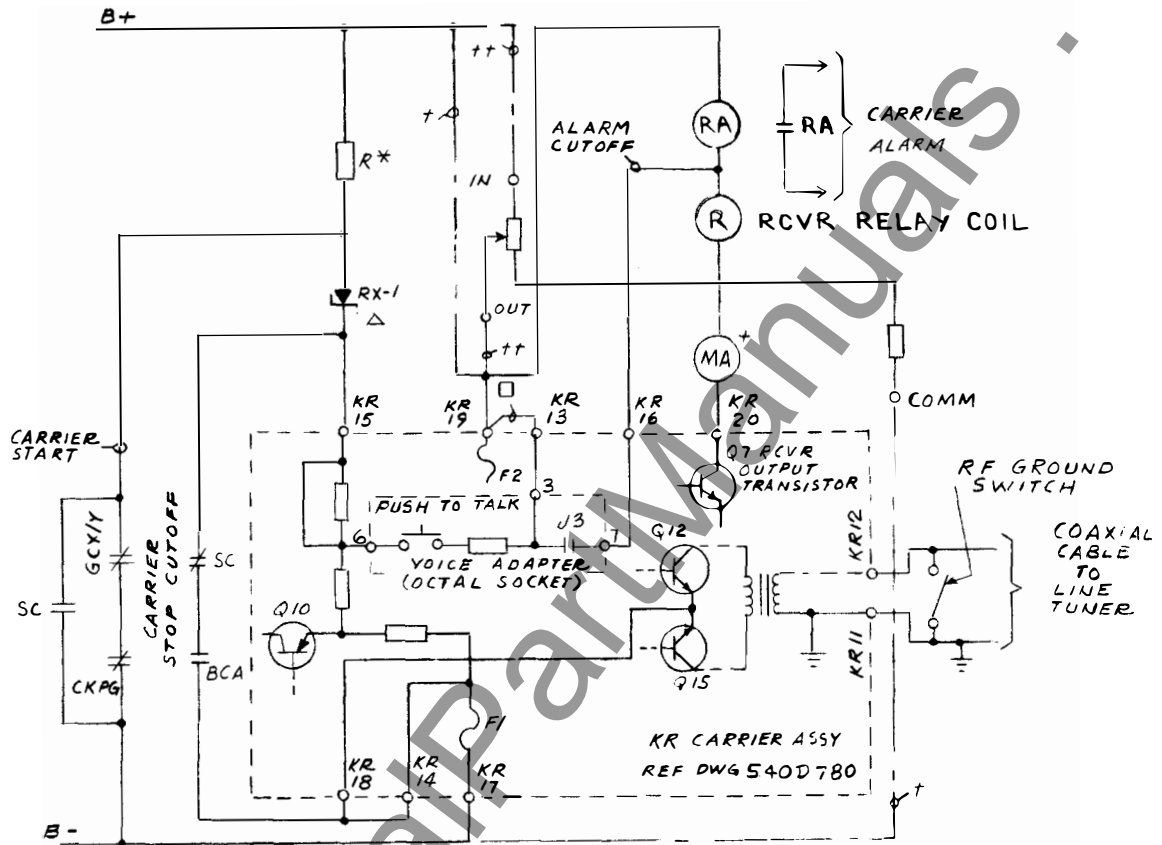

REQUIREMENTS FOR GCX/GCY RELAYING

SUPPLY VOLTAGE	CARRIER START	CARRIER STOP	R
51 VDC	+37V, 7MA	0 VOLTS	2K
129 VDC	+100V, 8MA	0 VOLTS	3.75K
258 VDC	+100V, 8MA	0 VOLTS	19.K

KR RELAYING TRANSMITTER /
REC. EXTERNAL CONNECTIONS
TERMINAL CONNECTION

- 11. GROUND
- 12. COAXIAL CABLE
- 13. SUPERVISORY PREFERENCE CONTACT
- 14. CARRIER STOP B- RETURN
- 15. CARRIER START (POSITIVE)
- 16. ALARM CUTOFF FOR COMMUNICATIONS
- 17. B MINUS
- 18. CARRIER STOP (HZ/HZM)
- 19. B PLUS
- 20. RELAY COIL

NOTES

- * FOR "R" USE OHMITE VITREOUS ENAMELED DIVIDOHM ADJUSTABLE 4K OR 20K 25W RESISTOR, CONNECT & ADJUST FOR VALUES SHOWN
- Δ TYPE IN3051
- + FOR 51 & 129 VDC SUPPLY
- ++ FOR 258VDC SUPPLY USE 330C191H01 RESISTOR UNIT REF DWG 223B497
- FOR SUPERVISORY CONTROL PREFERENCE CONTACTS

Fig. 5. Relaying Control Circuits - GCX/GCY (Dwg. 2-329C704)

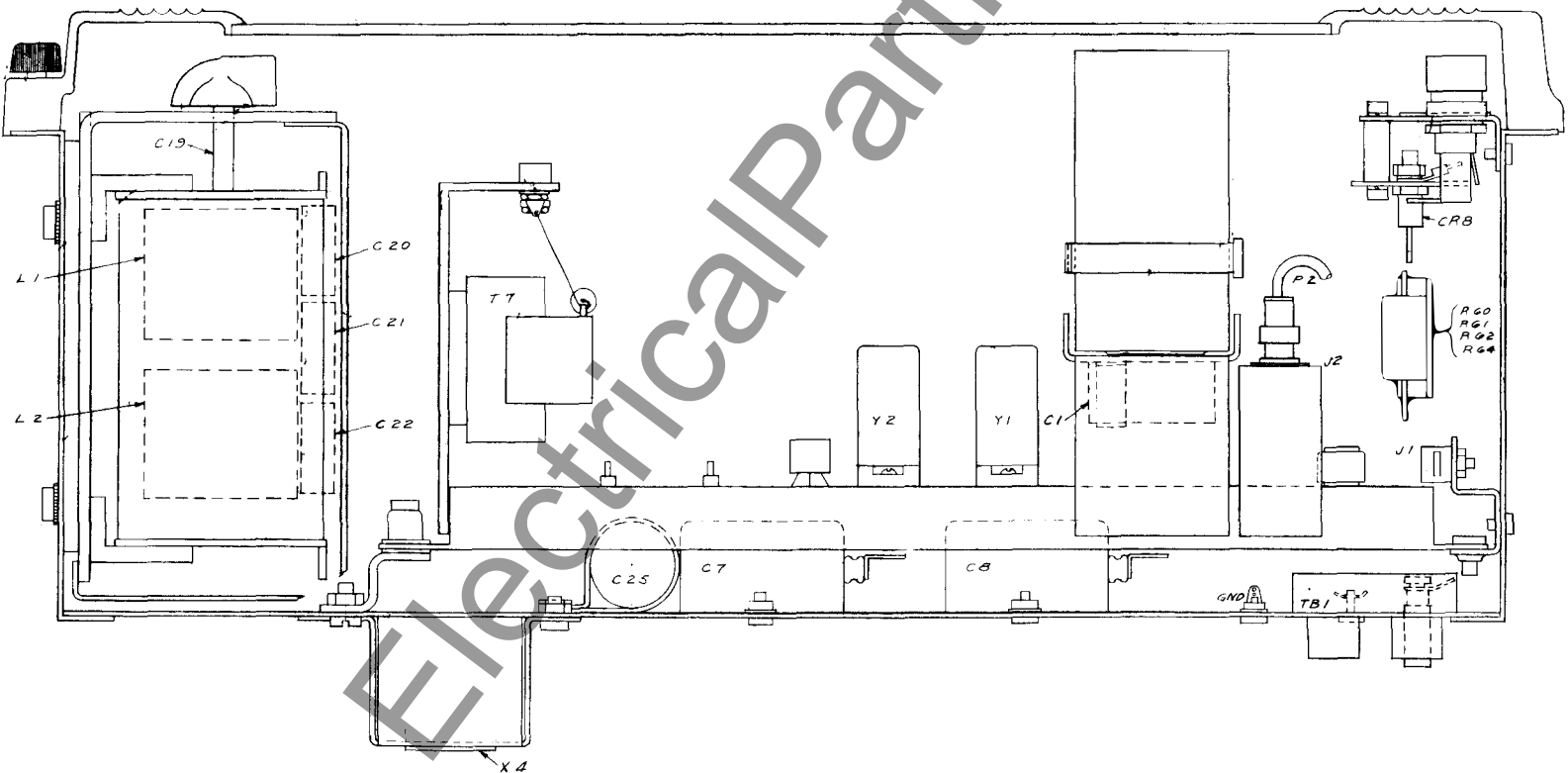
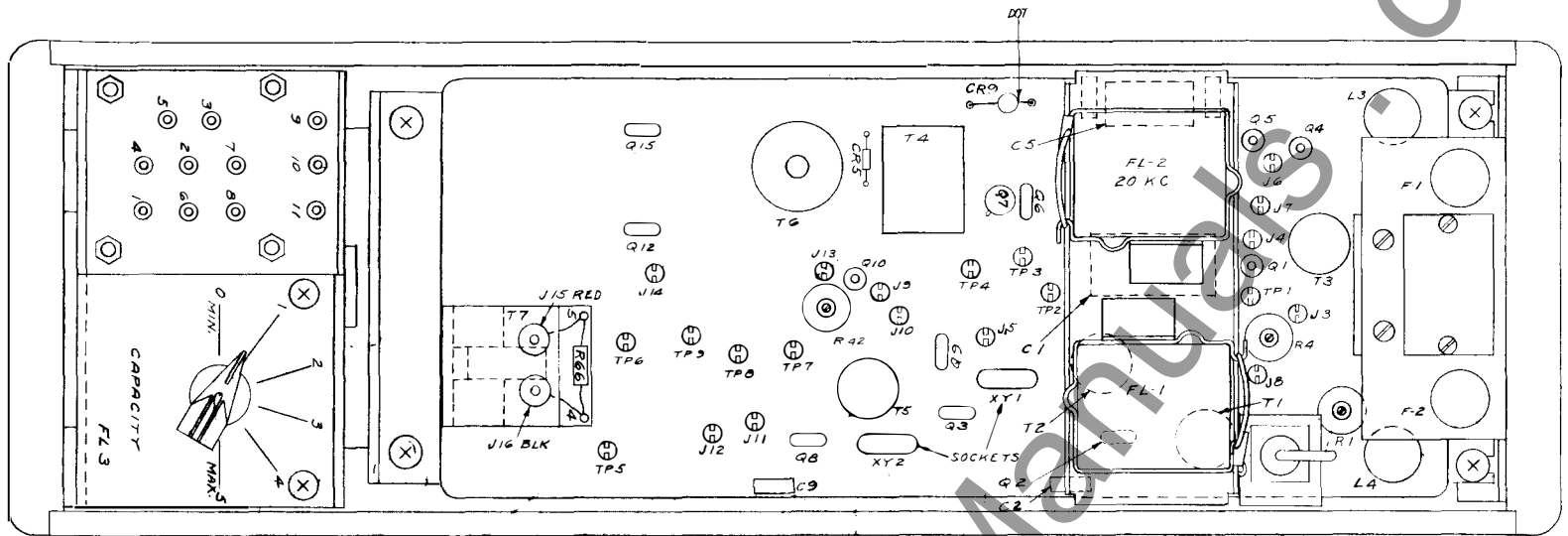

* Fig. 6. Component Location (Dwg. 540D781)

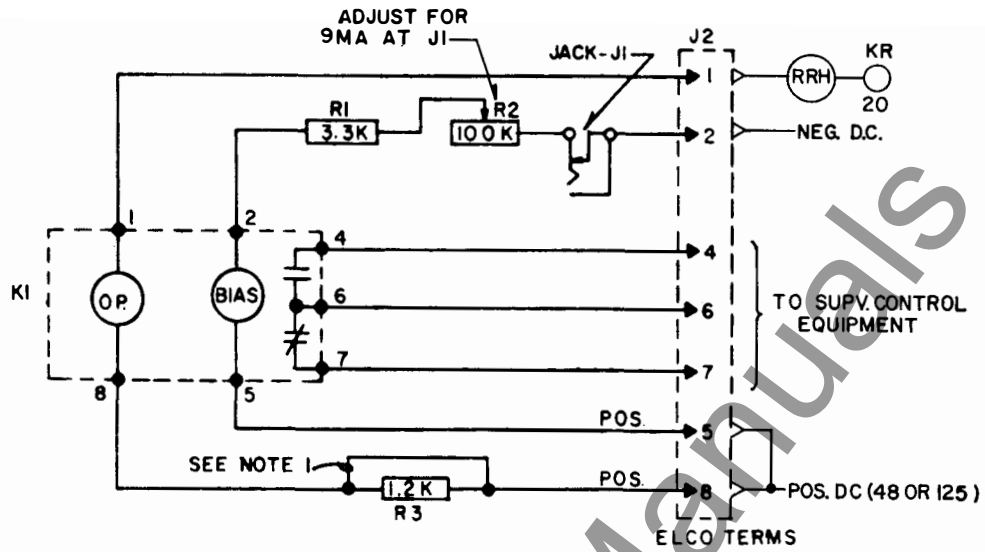

NOTES:

1. REMOVE FOR KR CARRIER PLUS SUPV. CONTROL WITHOUT RELAYING.
2. POLARITY SHOWN CLOSES CONTACT BETWEEN TERMINALS 4 & 6.

J 2

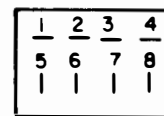

AS VIEWED FROM REAR OF PANEL

629A552

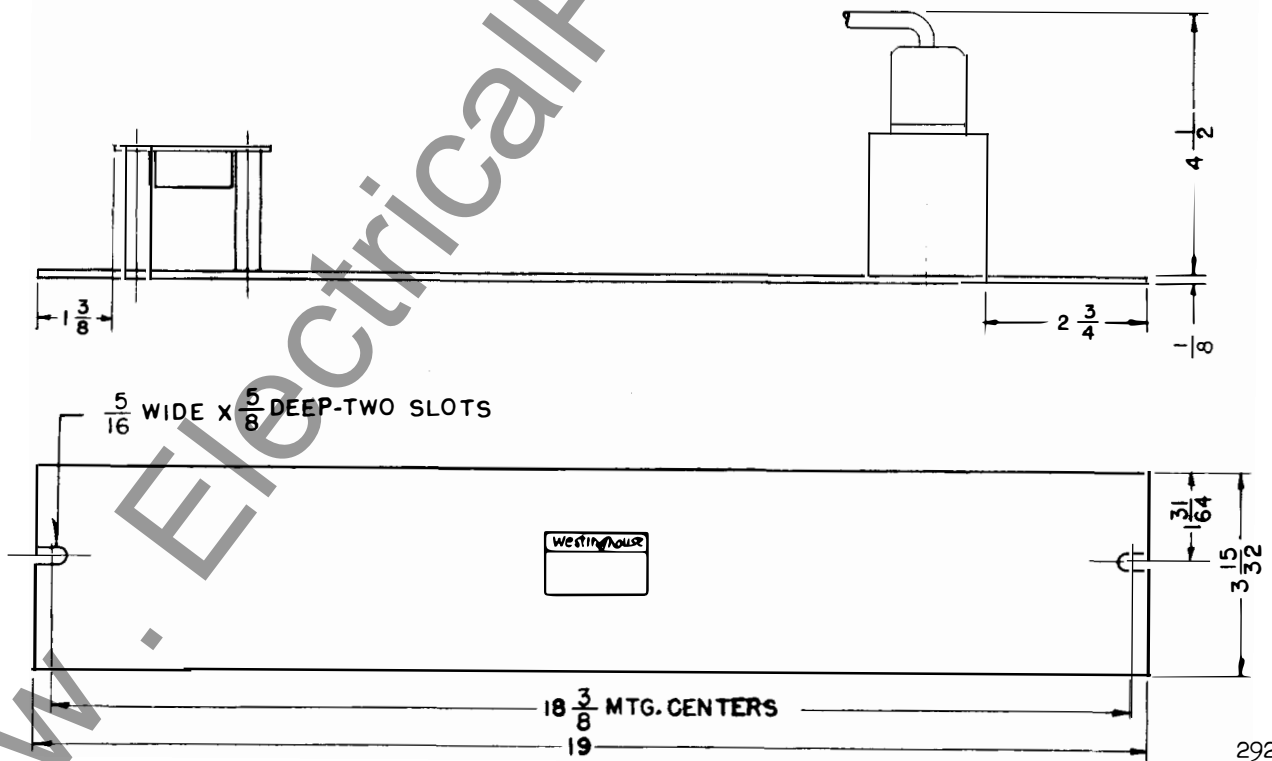

292B991

Fig. 7. Supervisory Control Auxiliary Relay Connections (Dwg. 629A552) and Outline (Dwg. 292B991).

**CONNECTIONS FOR 48-250 VOLT SERVICE AND
SUPERVISORY CONTROL APPLICATION
(CHANGES FROM JUMPERS SHOWN ON INTERNAL SCHEMATIC, FIG.2)**

250-VOLT OPERATION

FOR A 250 VOLT SUPPLY, RESISTOR UNIT 330C191H01 IS USED AS SHOWN ON APPLICATION DRAWING 329C704

FOR HZ/HZM OPERATION, THE JUMPER HAS BEEN REMOVED FROM TP-6 TO TP-7. (NOT REMOVED FOR K-DAR RELAYING).

RESISTOR UNIT SCHEMATIC:

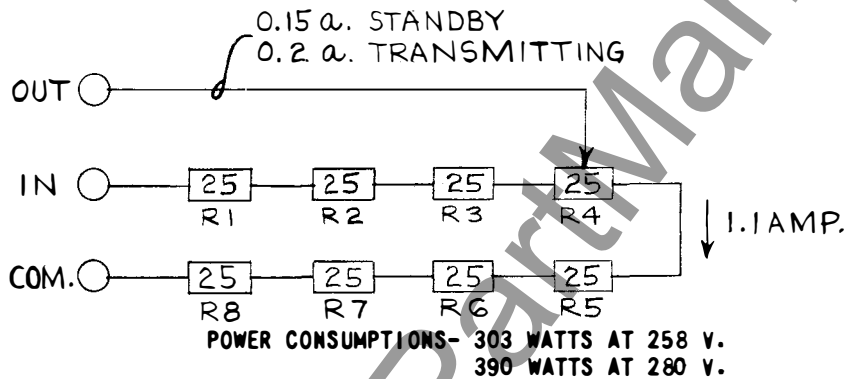

NOTE: KR SUPPLY VOLTAGE WILL BE APPROXIMATELY 144 VOLTS UNDER STANDBY CONDITION WHEN BATTERY VOLTAGE IS 280 VOLTS.

125-VOLT HZ/HZM OPERATION
JUMPER TP-7 AND TP-8 IS REMOVED.

48 VOLT OPERATION

ON PRINTED CIRCUIT BOARD ADDITIONAL JUMPERS ARE CONNECTED AS FOLLOWS:

- BETWEEN TP8 AND TP9
- BETWEEN TP5 AND J12
- BETWEEN TP1 AND TP2
- BETWEEN TP3 AND TP4

IN THE FT CASE, JUMPERS ARE CONNECTED ACROSS R60 AND R64, AND THE CONNECTION BETWEEN R64 AND DIODE CR8 IS REMOVED.

IN ADDITION, FOR 48-VOLT SUPERVISORY CONTROL, R59 IS CONNECTED INTO THE CIRCUIT.

Fig. 8. Connections, 48-250 Volts and Supervisory Control (Dwg. 407C971)

TRANSMITTER OUTPUT FILTER FL-3 CONNECTIONS

<u>LINE</u>	<u>FREQUENCY RANGE</u>	<u>COIL</u>	<u>COIL CONNECTIONS</u>	<u>PARALLEL CAPACITOR CONNECTIONS</u> Δ
1	27.7 KC-30.0 KC	L-1	(1-5) (3-6)	6-8-9-10-11
2	29.8 KC-33.1 KC	L-1	(1-5) (3-6)	6-8-10-11
3	31.8 KC-36.0 KC	L-1	(1-5) (3-6)	6-8-9-11
4	35.4 KC-39.0 KC	L-1	(1-5) (3-6)	6-8-11
5	38.0 KC-41.0 KC	L-1	(1-2) (3-6)	6-8-9-10-11
6	40.3 KC-45.0 KC	L-1	(1-2) (3-6)	6-8-10-11
7	43.0 KC-49.0 KC	L-1	(1-2) (3-6)	6-8-9-11
8	47.7 KC-56.0 KC	L-1	(1-2) (3-6)	6-8-11
9	49.5 KC-58.5 KC	L-1	(1-2) (3-6)	6-8-9-10
10	57.0 KC-72.3 KC	L-1	(1-2) (3-6)	6-8-10
11	67.0 KC-76.0 KC	L-2	(1-4) (6-7)	6-8-9-11
12	75.0 KC-88.0 KC	L-2	(1-4) (6-7)	6-8-11
13	77.5 KC-93.0 KC	L-2	(1-4) (6-7)	6-8-9-10
14	89.3 KC-114.5KC	L-2	(1-4) (6-7)	6-8-10
15	102.7KC-147.0KC	L-2	(1-4) (6-7)	6-8-9
16	136.6KC-210.0KC	L-2	(1-4) (6-7)	6-8

Δ CONNECTION FROM 6 TO 8 IS MADE BENEATH TERMINAL PLATE ON ALL SETS AT THE FACTORY.

Fig. 9. Connections - Output Filter (Dwg. 149A420)

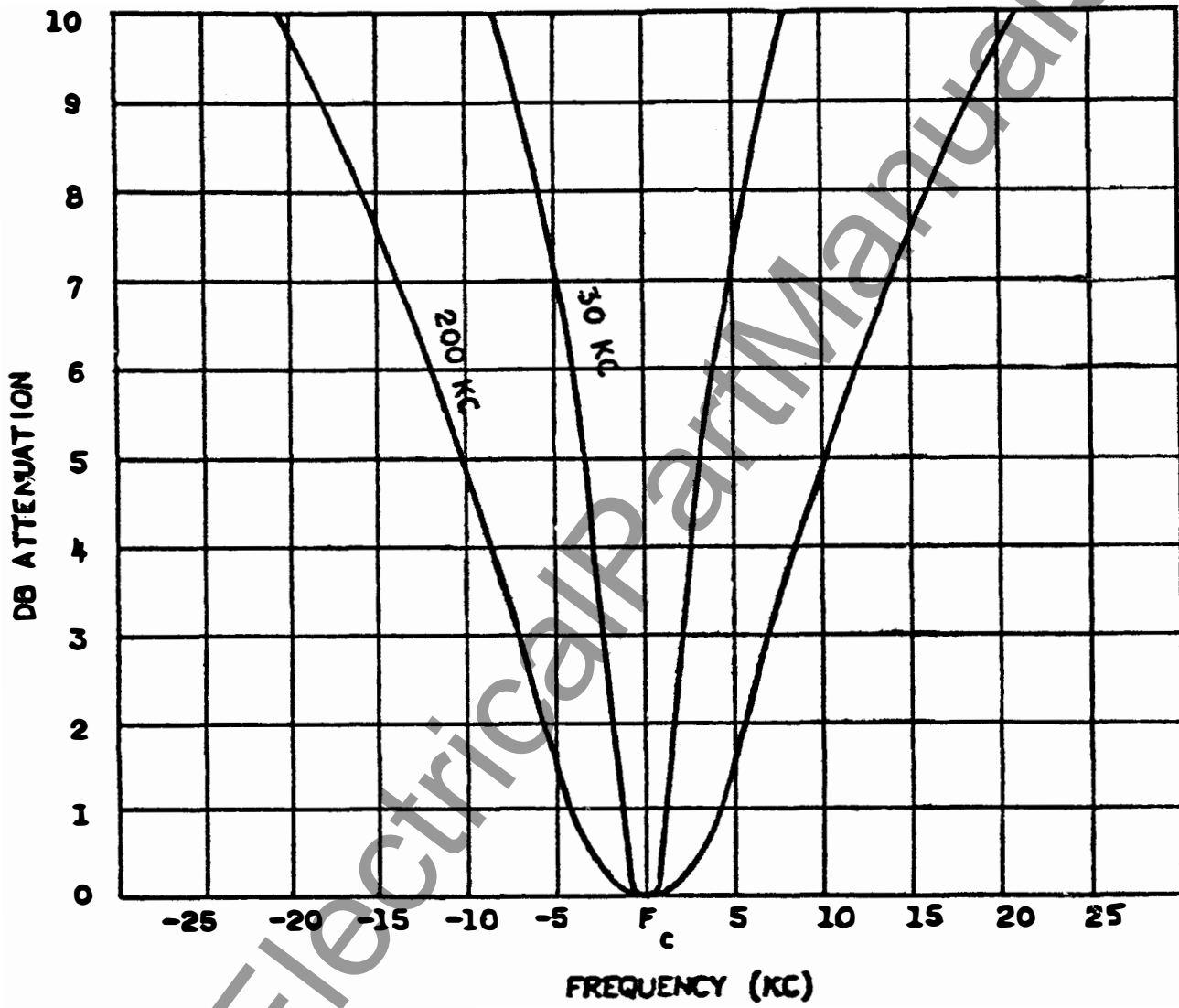

Fig. 10. Transmitter Output Filter Selectivity (Dwg. 377996)

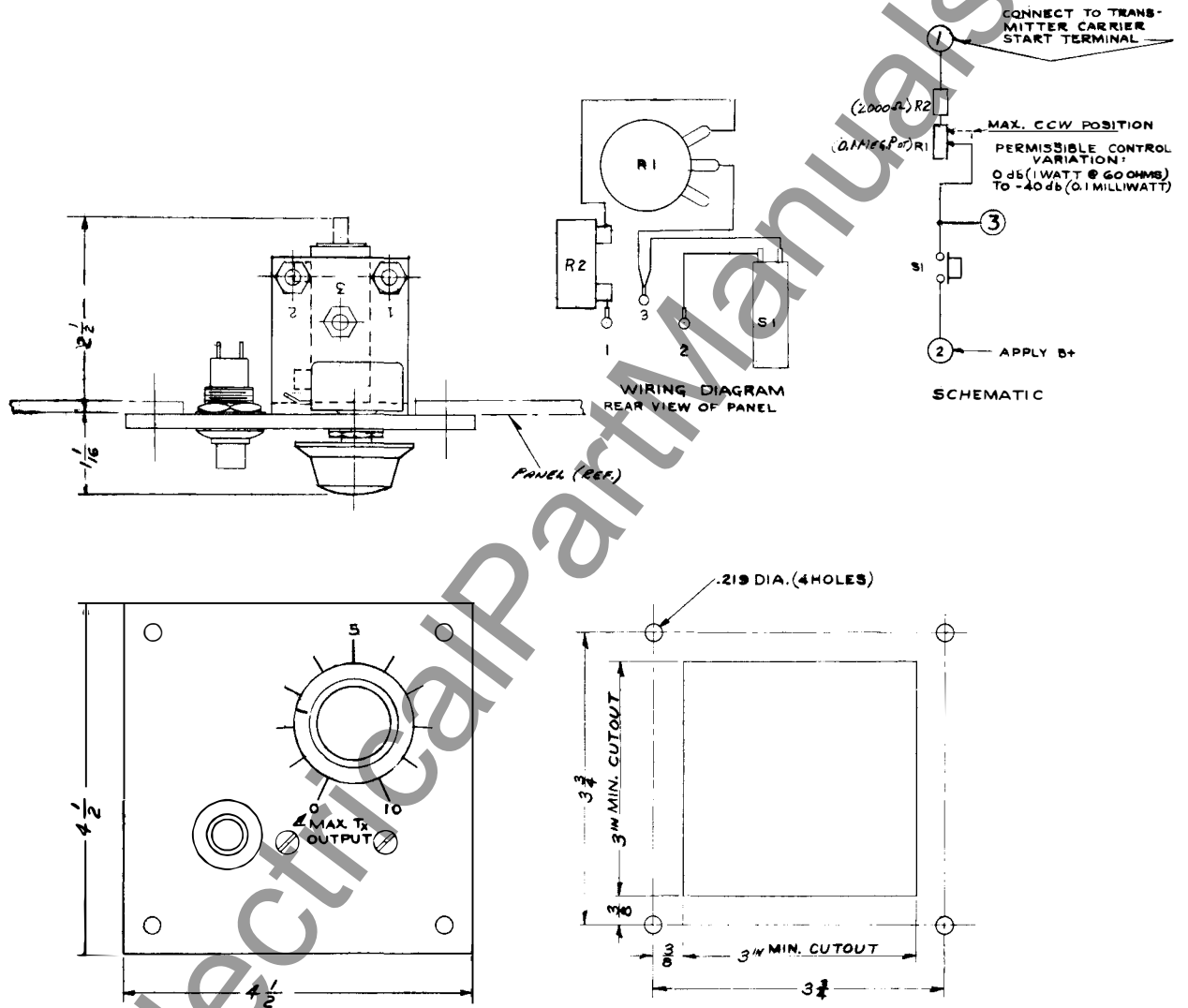

Fig. 11. Reserve Signal Detector Outline (Dwg. 329C703)

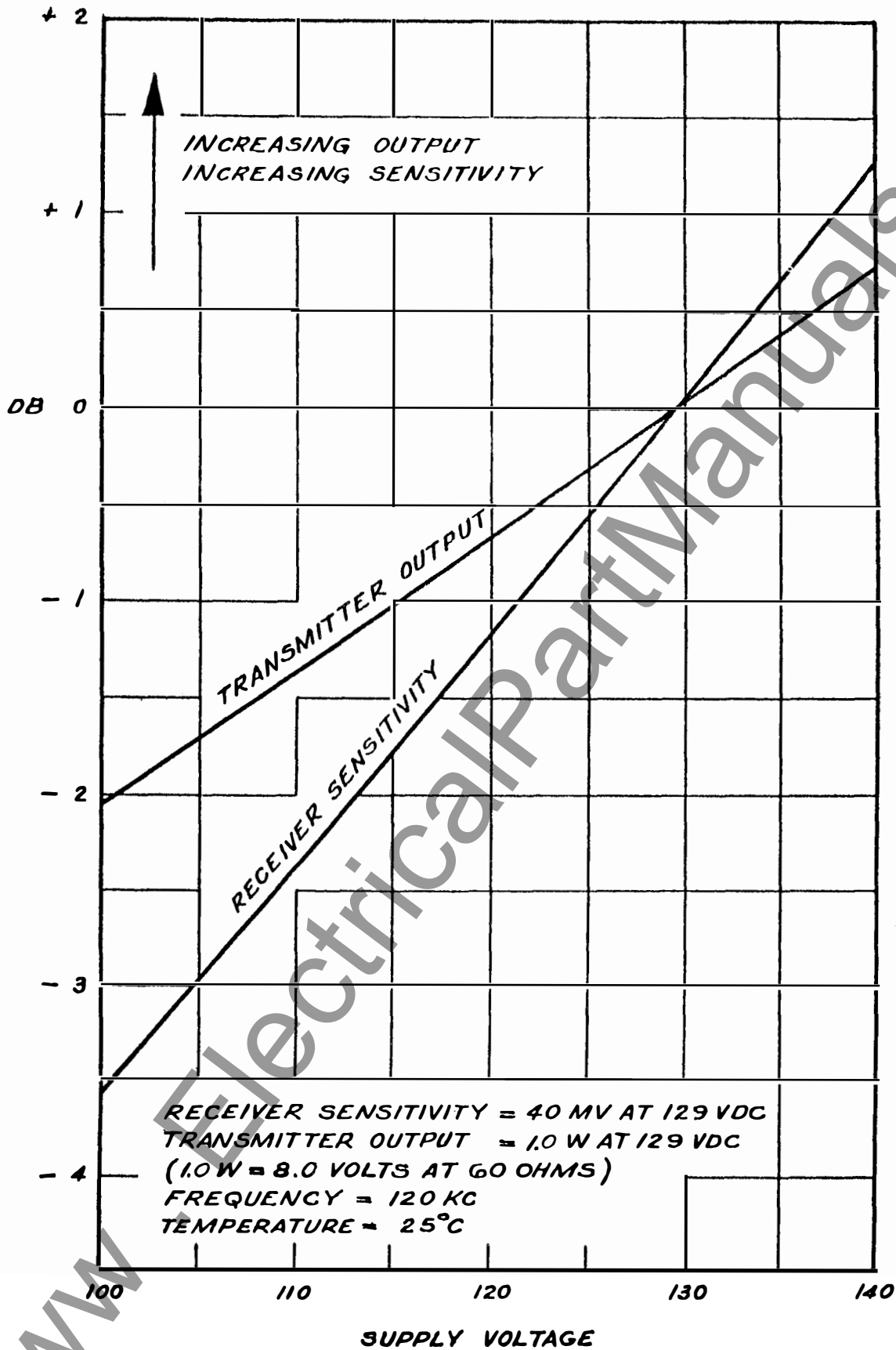

Fig. 12. Transmitter Output and Receiver Sensitivity Variations with Voltage (Dwg. 377999)

TRANSMITTER OUTPUT & RECEIVER SENSITIVITY VARIATIONS WITH FREQUENCY

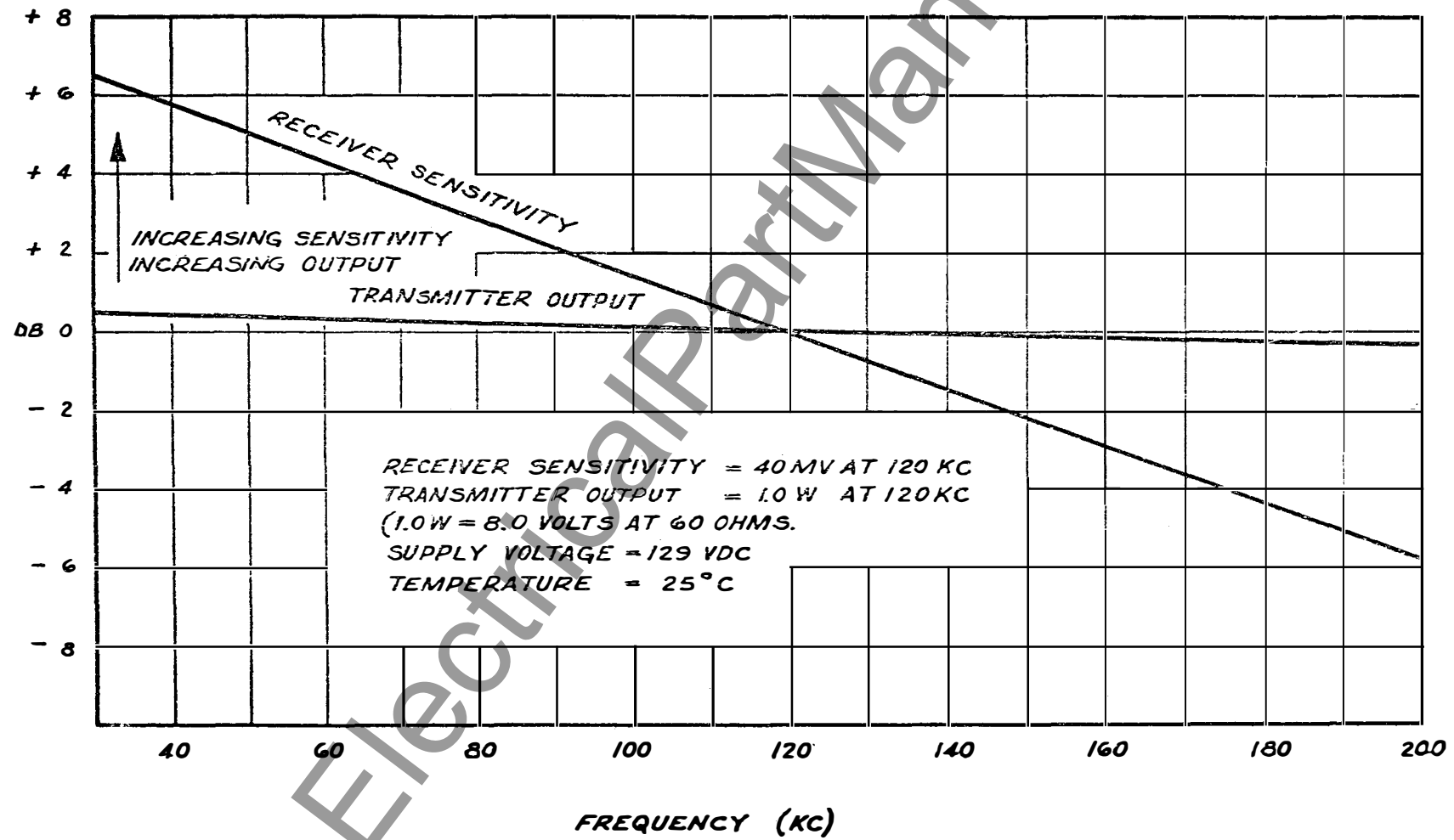

Fig. 13. Transmitter Output and Receiver Sensitivity Variations with Frequency (Dwg. 378000)

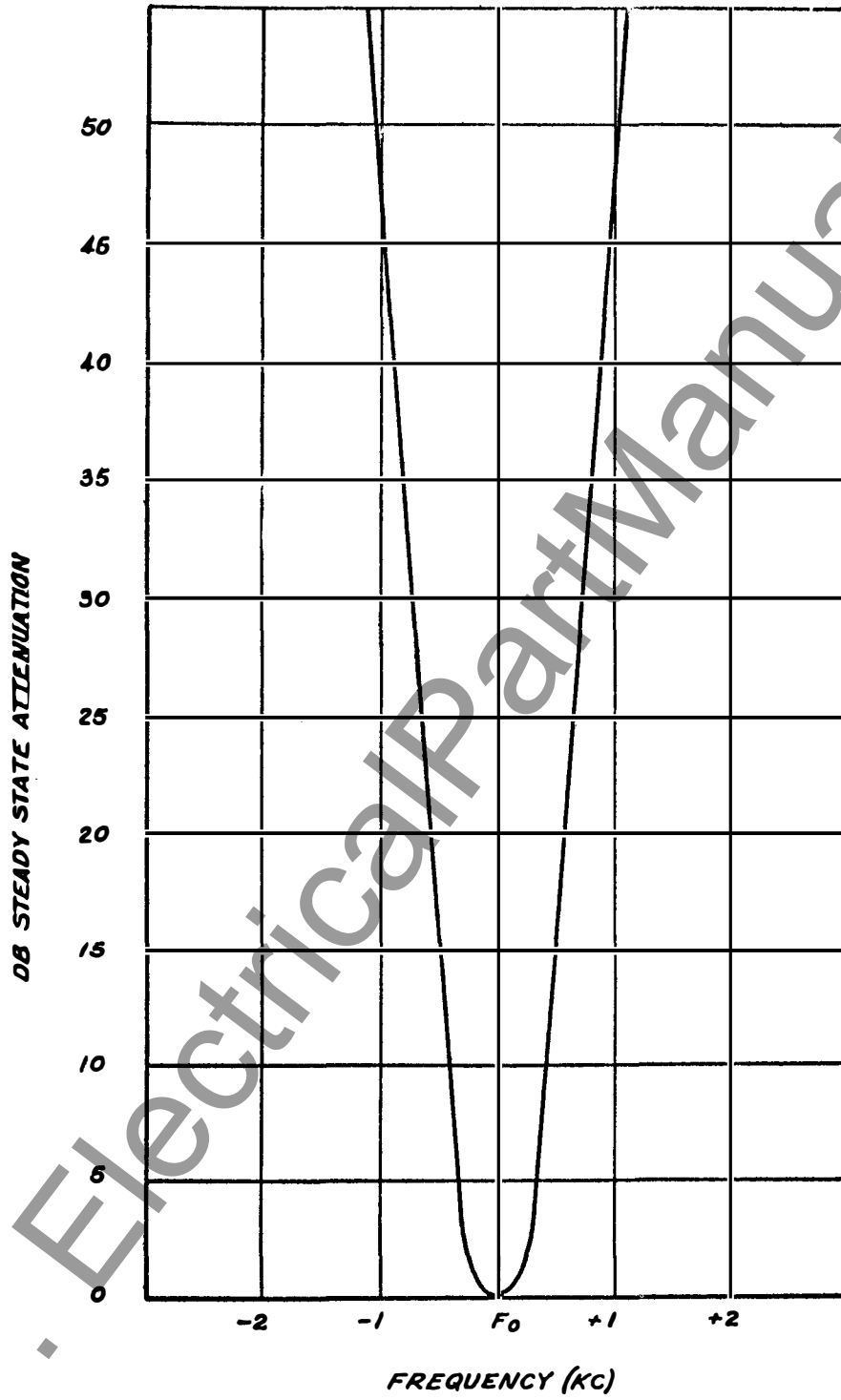
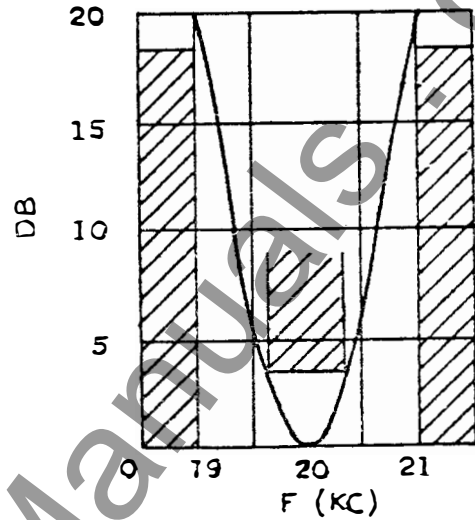
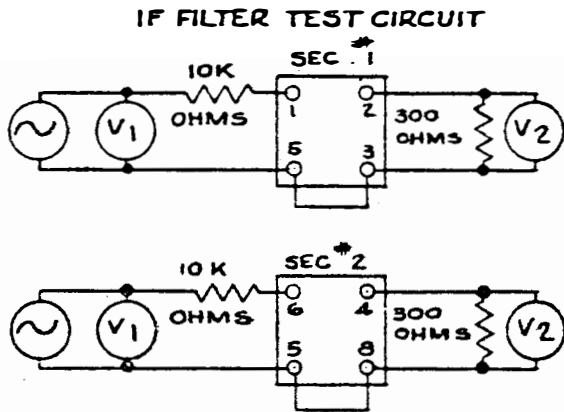
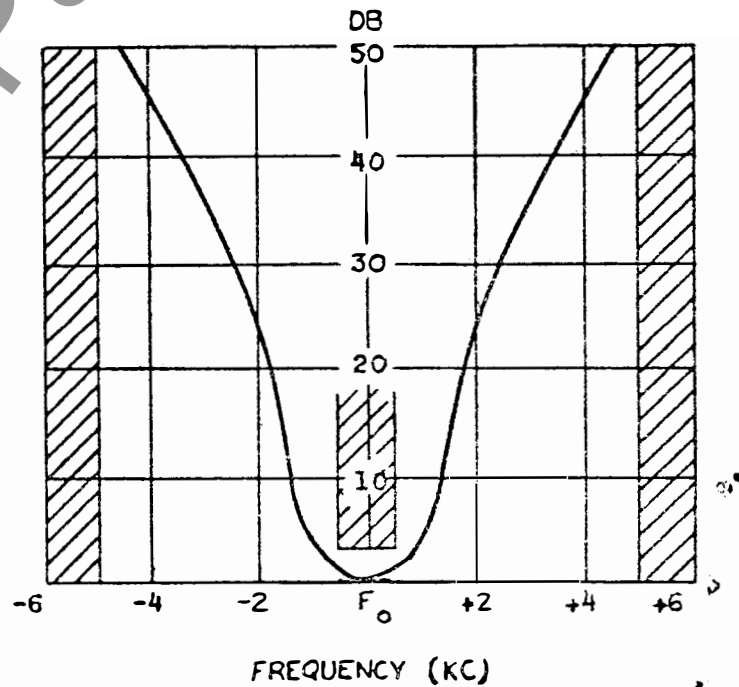
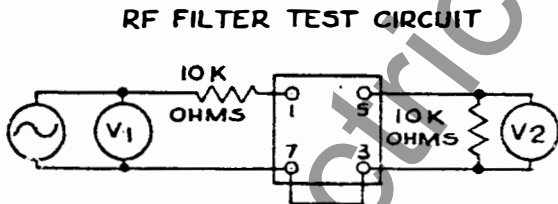

Fig. 14. Receiver Selectivity (Dwg. 377993)



Each section FL-2 requirement with typical selectivity curve
 Insertion loss 26 DB max.
 Including matching resistor.



FL-1 Requirement with typical selectivity curve at 120 KC. Insertion loss 18 DB max. Including matching resistor.

Fig. 15. Receiver Filter Limits (Dwg. 377995)

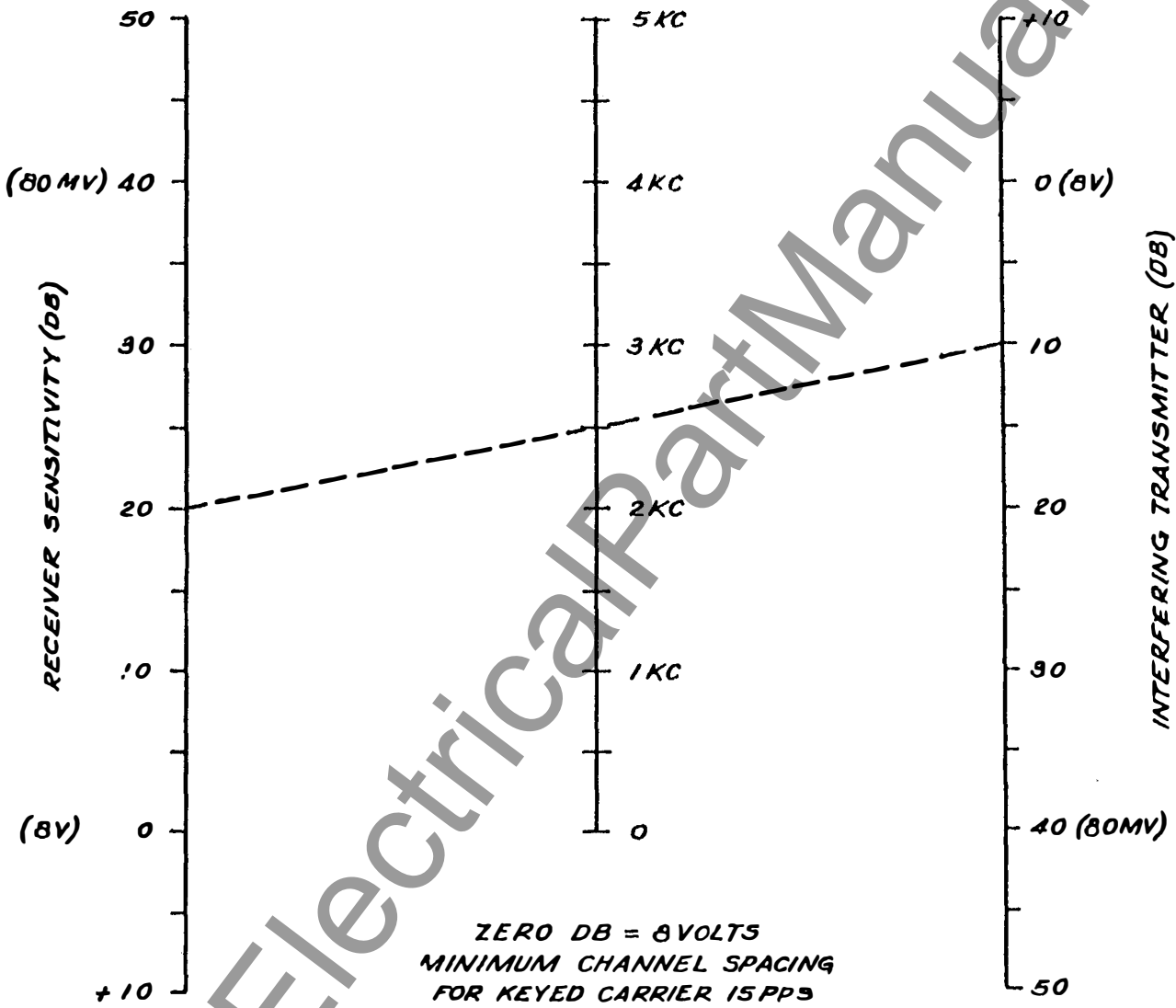
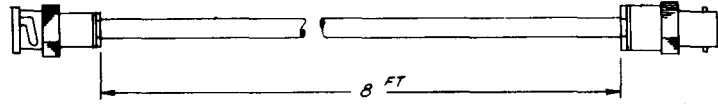
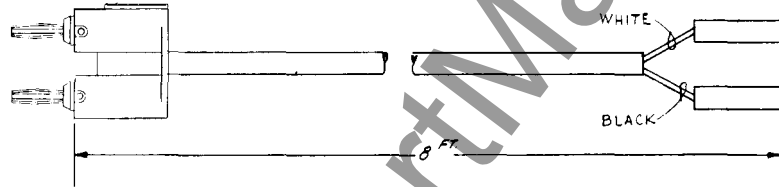

Fig. 16. Minimum Channel Spacing (Dwg. 377998)



Coaxial Lead...756D346 G02



Output Lead...756D346 G03

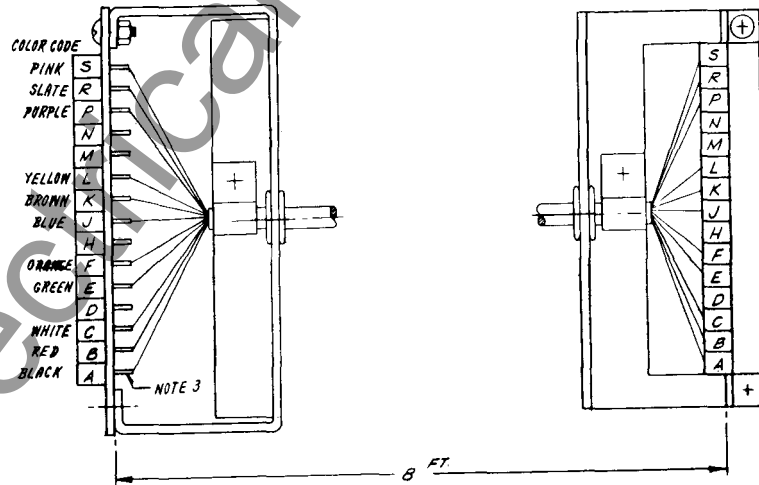

Main Harness... 756D346 G04

Fig. 17. Test Harness - (Complete Set)

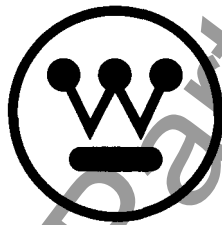

WESTINGHOUSE ELECTRIC CORPORATION
RELAY-INSTRUMENT DIVISION

NEWARK, N. J.

Printed in U.S.A.

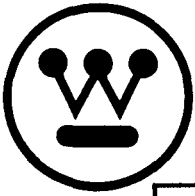

INSTALLATION • OPERATION • MAINTENANCE I N S T R U C T I O N S

TYPE KR CARRIER RELAYING TRANSMITTER-RECEIVER

Flexitest Case Mounted —with provision for rear-mounter Voice Adapter Accessories.	Style
KR Reserve Signal Detector	470D167 GO2
250 Volt Resistor Unit	330C191 H01
Test Harness (Complete Set)	756D346 G01
Coaxial Lead	756D346 G02
Output Lead	756D346 G03
Main Harness	756D346 G04

TABLE OF CONTENTS

Introduction	Page 2
Specifications	Page 2
Description	
General	Page 3
Mechanical	Page 3
Electrical	
Transmitter	Page 4
Receiver	Page 4
Transmitter Control Circuits	Page 5
Reserve Signal Detector	Page 5
Communications	Page 5
Relaying Control Circuits	Page 5
Installation	
General	Page 6
Connections	
External	Page 6
Internal	Page 7

Adjustments

Transmitter	Page 7
Receiver	Page 7
Reserve Signal Detector	Page 8
250-Volt Resistor Unit	Page 8
Frequency Change	Page 8
Maintenance	Page 9
Application	Page 13
Electrical Parts List	Page 14

LIST OF TABLES

Table

1 D-C Pin Jack Measurements with Reference to B-	Page 10
2 Transistor DC Measurements with Reference to B-	Page 11
3 D-C Bleeder Measurements with Reference to B-	Page 12
4 Typical RF Signal Measurements for Receiver	Page 12
5 Typical RF Signal Measurements for Transmitter	Page 13

*SUPERSEDES I.L. 41-941.1C
Denotes change from superseded issue.

LIST OF ILLUSTRATIONS

Figure	References
1 Outline – Flexitest Case	540D753
2 Internal Schematic	540D780
3 Relaying Control Circuits (HZ/HZM)	1-329C704
4 Relaying Control Circuits (K-Dar)	3-329C704
5 Relaying Control Circuits (GCX/GCY).....	2-329C704
6 Component Location.....	540D781
7 Supervisory Control Receiver Connection.....	223B498
8 Connections, 48-250 volts and Supervisory Control.....	407C971
9 Transmitter Output Filter Connections	149A420
10 Transmitter Output Filter Selectivity.....	C377996
11 Reserve Signal Detector – Outline and Schematic	329C703
12 Transmitter Output and Receiver Sensitivity Variations with D-C Voltage	C377999
13 Transmitter Output and Receiver Sensitivity Variations with Frequency.	C378000
14 Receiver Selectivity	C377993

15 Receiver Filter Limits	C377995
16 Minimum, Channel Spacing	C377998
17 Test Harness	756D346

CAUTION The voltages encountered in this equipment are dangerous to life. To be safe, disconnect the power source and close the grounding switch when servicing the equipment.

INTRODUCTION

The Type KR Relaying Transmitter-Receiver is designed for Distance Relaying, Telemetry, Supervisory Control and Sleet Detection. Facilities are provided for a plug-in type voice adapter. The basic design is for operation from 125-volt station batteries. However, the apparatus may also be operated from 48-volt or 250-volt station batteries by means of various internal connections. These various connections as well as most of the adjustments are made at the factory, although they can be changed in the field.

Although designed primarily for operation with Westinghouse protective relays, this apparatus may also be coordinated with other types of directional-distance relays and with most other contact keyed devices.

SPECIFICATIONS

Frequency Range.....	30-kc to 200-kc
Channel Attenuation Rating	40-db
Transmitter Power Output.....	1.0 watt at standard conditions (see Figs. 12 and 13). 0.5 watt with a 48-volt d-c supply.
Transmitter Harmonic Output	At least 46-db below fundamental.
Transmitter Output Impedance.....	Matches one 60-ohm coax. cable. (Suitable for 50-70 ohm cable.)
Transmitter Output Filter Selectivity	See Fig. 10
Transmitter and Receiver Oscillator and Frequency Stability	From -20° C to +50° C with simultaneous voltage variations from 100 to 140 VDC, the frequency remains within 0.01%.

Permissible Battery Voltage Ripple	7-1/2%
Ambient Temperature Range	-20°C to +50°C.
Non-Operating Temperature Range	-40°C to +70°C
Receiver Sensitivity	0.04 volts at standard conditions (see Figs. 10 and 18).
Receiver Selectivity	See Fig. 14
Receiver Signal-to-Noise Ratio Requirements	12-db
Minimum Channel Spacing	See Fig. 16
Power Input	115-ma at 48 VDC, 200-ma at 125 VDC, 1.28 amperes at 250 VDC.
Carrier On-Off Keying	Requires one pair of contacts capable of keying 8-ma DC at an open circuit voltage of 125 VDC.
Weight (With Flexitest Case)	Approximately 16-lbs.

CAUTION Refer application to Westinghouse when other transmitters are to be connected to the same coax cable as certain conditions may result in damage to the output transistors.

NOTE Standard conditions are taken as 129-volts, 120-kc and 25°C.

or silicon semi-conductor materials. The junction transistor consists of a thin slice of germanium or silicon with three different regions produced by introducing specific amounts of impurities. A thin wire is connected to each region. One outer region is called the emitter, the other the collector, and inserted between them is the base. These correspond roughly to the cathode, plate, and grid of a vacuum tube.

DESCRIPTION

General

This completely transistorized carrier-apparatus is a result of extensive field and laboratory tests. From these tests, it was proven that transistors provide superior reliability over tubes. In addition, the latest printed circuit and filter techniques have improved performance and greatly decreased the size. The expected long life of transistors as compared with vacuum tubes will reduce maintenance costs, and the low power requirements will produce important savings in battery and charger requirements.

Transistors perform the same functions as vacuum tubes. However, tubes operate by the flow of electrons in a vacuum between elements, while transistors depend upon the movement of electrons in a solid. This leads to a more rugged type of construction. Most transistors are made from either germanium

The transistors in this equipment are of the junction type, and both NPN and PNP configurations are used. In the NPN transistor, the majority of the current is carried by electrons. In the PNP transistor there is a deficiency of electrons. These deficiencies are known as "holes". For practical purposes holes may be considered as positively charged "electrons", and these provide most of the current flow in PNP units. In order to obtain maximum efficiency and reliability, both types are used in this equipment.

Silicon transistors are used in the transmitter and receiver output circuit in order to stabilize critical circuit performance at elevated temperatures.

Mechanical

This apparatus is supplied in a Flexitest case and may be either flush or projection mounted in

order to match other switchboard equipment. The outline dimensions and also the drilling plan for flush and projection mounting are shown by Fig. 1. The majority of the parts are mounted on a printed circuit board. This board may be readily removed as follows:

1. Remove the two output plugs from the red and black jacks.
2. Disconnect the receiver input coaxial cable connector.
3. Loosen the two screws at the top of the board.
4. Loosen the two screws at the bottom of the board and pull them out as far as they will extend.
5. Pull board down to disengage the terminals and lift out.

The transmitter output filter may be removed by removing four mounting screws from the bottom of the case and disconnecting the coaxial cable.

Fig. 6. shows the location of major components such as potentiometers, jack, test points, crystals, transistors, etc. External connections and the Schematic Diagram are shown by Fig. 2. The numbered terminals shown as squares apply to the external terminals.

Provisions are made for plugging the Voice Adapter Unit in the rear of the relaying equipment. Octal socket marked X-4 on the rear of the set accommodates the adapter plug. A buckle type strap on each side of the adapter holds the unit in place after it has been plugged in. The normal projection for a rear mounted Voice Adapter is 3-inches beyond that of the relaying equipment. When the KR Relaying Unit is supplied with the adapter, a patch cord is available on separate order. This patch cord plugs into the telephone jacks on the adapter and provides an extension to a conveniently located terminal board.

The panel cutout information necessary for mounting the Sleet Detector is shown by Fig. 11. This unit consists of a potentiometer and pushbutton switch mounted on a small panel, itself suitable for switchboard mounting.

For 250-volt operation, separate auxiliary resistors are required, as shown in Fig. 8.

Electrical

Transmitter

The transmitter is made of four main stages in -

cluding an oscillator, driver, power amplifier, and an output filter. In the oscillator, the crystal is operated as a resonant circuit between the collector of one transistor and the base of the other. The feedback is supplied through a capacitor from the collector of the second transistor to the base of the first transistor. The frequency is independent of voltage or temperature changes of the transistors. Thus the frequency stability is the stability of the crystal.

The input to the driver stage Q-10 is controlled by potentiometer, R-42 which also controls the transmitter power output. In HZM relaying CARRIER STOP provides about +40 volts for blocking. This is applied to Q-10 through T-6. Diode CR-5 prevents damage to the transistor when this positive voltage is applied to the collector. For CARRIER START (when in the blocked position) a small positive voltage is applied to the collector of Q-10 by means of bleeder resistors R-67 and R-68.

The power amplifier consists of two transistors Q-12 and Q-15, which are operated as class B amplifiers in push-pull. Resistors R-52 and R-55 are for stabilization.

The output transformer, T-7, matches coaxial cables of 50 to 70 ohms.

Resistor R-66 tends to keep the source impedance constant to permit proper tuning of the output filter.

The output filter consists of coils L-1 and L-2, capacitors C-19 through C-22. The filter is tunable, and is provided to attenuate harmonics and other spurious outputs. It should be noted that the filter contains no shunt elements, resulting in a reverse impedance free of "across the line" resonances.

Receiver

The receiver is a superheterodyne in order to obtain constant selectivity regardless of the channel frequency. (See Fig. 14.) The major stages include an input filter, attenuator, oscillator, mixer, IF filters, IF amplifiers, detector and a D-C power output stage.

The input filter prevents undesired signals from producing the IF frequency.

The receiver sensitivity is adjusted by means of the continuously variable input control R-1 and by

connecting or disconnecting resistors R-73 and R-74 in the IF stages.

The receiver oscillator (Q-2 and Q-3) is basically the same as the transmitter oscillator. The frequency is 20-kc above the incoming signal frequency.

The receiver channel frequency is determined by the input filter and the oscillator crystal. The frequency may be changed readily since both the filter and the crystal are plug-in components.

Mixing is accomplished by feeding the incoming signal to the emitter and the receiver oscillator signal to the base of the mixer Q-1. Mixer oscillator requirements are met through adjustment of potentiometer R-4. Injection into two separate elements, base and emitter, provides a circuit capable of handling greater signal level variations than one in which injection is made into only a single element such as the base.

This receiver uses an IF frequency of 20-kc. The overall selectivity is determined primarily by the IF filter FL-2. Typical characteristics of this filter are shown in Fig. 15.

The IF amplifier consists of transistors Q-4, Q-5 and Q-6.

The detector is a full wave bridge rectifier. This rectifier in conjunction with the IF amplifier Q-6, provides the necessary power to drive the D-C power output stage Q-7.

The final output stage Q-7 will supply approximately 18 milliamperes to a standard 1700 ohm distance relay RRH coil and its associated 500 ohm alarm coil. It may also be used to drive other relay coils such as is shown by Fig. 7, Supervisory Control Connections.

Transmitter Control Circuits

In the standby condition, although the oscillator is running, the transmitter driver has no emitter bias which results in no output.

Positive voltage applied to terminal 15 supplies this bias through a voltage dividing network, and transmitter output results. The actual configuration of the network is a function of supply voltage and application (Relaying, Telemetering, etc.) and is

discussed in the Adjustments section.

Output may be stopped in several ways. The method used with K-DAR relays is to remove the positive voltage applied to terminal 15. In the case of distance relaying with Westinghouse HZ/HZM relays, application of a positive voltage to terminal 18 will stop the transmitter output. Output may also be stopped by removal of negative battery from terminal 18.

Reserve Signal Detector

The Reserve Signal Detector is shown by Fig. 11. Effectively R-1 is a remote transmitter output control. This control is obtained through varying the driver stage (Q-10) emitter bias, and is effective over a 40-db range of transmitter output. The detector is switched into service by S-1. By adjusting R-1 for a given receiver relay current at the far end of the channel, a relative measure of the channel attenuation may be obtained. This is discussed further in the section on Adjustments.

Communications

The transmitter output is reduced approximately 6-db when the Type KR voice adapter attachment is used. Relaying takes preference, and full output is obtained since full voltage is supplied to terminal 15.

Relaying Control Circuits

Figs. 3, 4 and 5 show simplified diagrams of the relaying control circuits.

1. K-DAR and GCY Relaying (Figs. 4 and 5)

The control of the carrier set is obtained through the CARRIER START and CARRIER STOP contacts. These contacts are shown in their normal standby condition.

The K-DAR or GCY relays operating from the voltage and current on the transmission line, detect and determine the direction of a line fault and thereby control the carrier transmitter and receiver.

The control of the carrier set is such as to start the transmission of carrier when fault power on the transmission line is flowing out of the line section being protected. Conversely, when fault power is flowing into this line section, the control is such as to block the transmitter and keep it from being turned on by secondary functions such as sleet detection

TYPE KR CARRIER SET

and communication, should these functions be in use at the same time. Should carrier be received from the remote station, the hold coil and alarm coil will energize through transistor Q-7 in the receiver.

When carrier start operation occurs, the CARRIER START contact opens applying a positive voltage (see Figs. 4 and 5) to terminal 15 of the carrier set. This puts a potential on the driver stage in the transmitter and also applies proper bias for the power amplifier.

When a carrier stop operation occurs, the CARRIER STOP contact closes, which removes B+ (terminal 15) from the driver and the power amplifier stages in the transmitter. CARRIER STOP, terminal 18, on the carrier set is permanently connected to terminal 14, for K-DAR and GCY relaying.

2. HZM Relaying (Fig. 3)

The control of the carrier set is effected by the CARRIER START and the CARRIER STOP contacts. These contacts are shown in their normal standby condition.

The HZ-HZM relays operating from the voltage and current on the transmission line, detect and determine the direction of a line fault and thereby control the carrier transmitter and receiver.

The control of the carrier set is such as to start the transmission of carrier when fault power on the transmission line is flowing out of the line section being protected. Conversely, when fault power is flowing into this line section, the control is such as to block the transmitter and keep it from being turned on by secondary functions such as sleet detection and communication, should these functions be in use at the same time. Should carrier now be received from the remote station, the hold coil and alarm coil will energize through transistor Q-7 in the receiver.

When carrier start operation occurs, the CARRIER START contact closes applying the full battery supply voltage to terminal 15 of the carrier set. This puts a potential on the driver stage in the transmitter and also applies proper bias for the power amplifier.

When a carrier stop operation occurs, the CARRIER STOP contact opens. This applies a positive voltage (see Fig. 3) to terminal 18 which blocks the driver stage and the power amplifier stage

It is possible under certain conditions that the signals from two transmitters, attempting to block a third receiver, would be of such amplitude, phase and frequency as to cause the RRH coil current to "pulsate". It would then be possible to have a false trip.

In the case of the KR set for relaying 3-terminal lines, the transmitter frequencies (to avoid this possibility of false trip) should be separated by 100 cycles. All receivers and one transmitter would be for the desired center frequency. One of the other transmitters would be 100 cycles above, the other 100 cycles below this center frequency.

INSTALLATION

General

Upon receipt of a unit, whether shipped separately or in an assembly, an immediate inspection should be made. Carefully check for damage or shortages.

For necessary clearances and mounting dimensions, see the following illustrations:

Flexitest Case Mounting..... Fig. 1

Sleet Detector..... Fig. 11

Connections

External

The external connections will vary slightly depending on the application, but in general will be along the lines described as follows: (Refer to the Schematic Diagram, Fig. 2.)

Terminals 11.....	Ground
12.....	Coaxial Cable
13 and 19.....	Supervisory Preference Contacts
14.....	B- "CARRIER STOP" return
15.....	Battery positive through carrier start contacts
16.....	Battery positive for alarm cutoff (used with com- munication)
17.....	B-
18.....	Carrier Stop for HZM Relaying
19.....	B+
20.....	Relay Coil

CAUTION If the transmitter output load is removed while the transmitter is energized, the transistors in

the power amplifier will be permanently damaged. A dummy load should be connected to the transmitter output if the coax is disconnected and the transmitter is to be energized.

When tuning line coupling equipment, short the coaxial cable to ground before changing taps on the Line Tuner or matching transformer.

Internal

Necessary internal connections are generally made at the factory, to customer order, before apparatus shipment. For reference purposes, these are outlined in the following tabulation. Check the proper bleeder resistors before applying voltage to the equipment.

OPERATION	BLEEDER RESISTORS IN THE CIRCUIT
48-Volt K-DAR, HZM, and GCY Relaying, Telemetering, and Supervisory	R-47 and R-48
125-Volt K-DAR and GCY Relaying	R-45, R-47 and R-48
125-Volt HZM Relaying, Telemetering, and Supervisory	R-41, R-45, R-47 and R-48
250-Volt K-DAR and GCY Relaying	R-45, R-47 and R-48
250-Volt HZM Relaying, Telemetering, and Supervisory	R-39, R-40, R-41, R-45, R-47 and R-48

Various combinations of the inductors and capacitors of the transmitter output filter are required depending on the channel frequency. These are tabulated in Fig. 9.

Adjustments

This apparatus is generally tuned to and tested at the specified channel frequency before shipment. Final adjustments must be made in the field and are described in the following paragraphs. Fig. 6 shows the locations of the various controls.

Transmitter

1. Disconnect the coaxial cable and replace with a 50, 60, or 70 ohm non-inductive resistor depending on the characteristic impedance of the cable used.

2. Fig. 9 shows typical output filter connections for various frequency ranges. In some cases it may be necessary to use either a higher or lower range to tune the filter to resonance.

3. Insert fuses F- 1 and F- 2 to apply power to the apparatus.

4. Connect an A-C Vacuum Tube Voltmeter (VTVM) across the non-inductive load.

5. Unblock the transmitter by closing the CARRIER TEST SWITCH. An alternative is to jumper battery positive to terminal 15.

6. Beginning with the output control R-42 at the maximum counterclockwise position, advance it clockwise until a reading appears on the VTVM. Tune capacitor C-19 for a maximum voltmeter reading.

7. While increasing R-42, tune the output filter for maximum output until the output across the resistor is approximately 8 volts. (See Figs. 12 and 13.) (Approximately 5.5-volts when operating from 51-volt station battery.)

8. Open the test switch and reconnect the coaxial cable.

Receiver

1. The oscillator output control R-4 is pre-set at the factory. However, should any of the oscillator components be changed (including the transistors and the crystal) R-4 will require adjustment.

a. Connect an A-C VTVM to jacks J-3 and J-4.

b. Adjust R-4 for a 0.3 volt reading on the meter.

2. The unit is shipped to have a gain of approxi-

mately 250 millivolts (to produce 10 ma relay current) with input control R-1 in maximum clockwise position. About 10-db additional gain or 80 millivolt sensitivity can be obtained by clipping out resistor R-74, which is connected to the base of Q-4 and the B+ supply for the IF. Approximately 10-db gain or 25 millivolt sensitivity can be obtained by clipping out resistor R-73, which is connected to the base of Q-5 and the B+ supply for the IF. Resistor R-71 has been selected at the factory to provide an overall gain of approximately 25 millivolts.

a. Sensitivity Adjustment for Noise

If the maximum on-frequency noise level is known or can be measured, the receiver can be adjusted for this level. Disconnect the coaxial cable and connect a 60-ohm non-inductive resistor and a VTVM across terminals 11 and 12. Energize the transmitter and output control R-42 for the same output as the maximum noise. Then adjust the receiver input control R-1 to obtain 1-ma output current. If it is impossible to obtain 1-ma output current with control R-1 in the maximum clockwise position, then clip out resistor R-74, which is connected to the base of Q-4. If the gain is still insufficient, clip out resistor R-73, which is connected to the base of Q-5. After completing the adjustment of R-1, restore the transmitter to full output.

b. Sensitivity Adjustment for Remote Signal

When the maximum on-frequency noise is unknown and cannot be conveniently measured, the receiver may be adjusted for the remote signal. First determine the channel attenuation using a Sierra voltmeter or some other convenient method. Disconnect the coaxial cable and connect a 60-ohm non-inductive resistor and a VTVM across terminals 11 and 12. Add 15-db to the channel attenuation. This compensates for average variations such as channel and voltage variations. For example, if the channel attenuation is 5-db, add this to the 15-db making a total of 20-db. Taking this from 8 volts output of the transmitter, the receiver should then be set for a sensitivity of 0.8 volts. To do this, adjust the transmitter output control R-42 for 0.8 volts and then adjust the receiver input control so as to obtain 10-ma output current. If it is impossible to obtain 10-ma output current with control R-1 in the maximum clockwise position, clip out resistor R-74, which is connected to the base of Q-4. If the gain is still insufficient, clip out resistor R-73, which is connected to the base of Q-5. After completing the

adjustment of R-1, restore the transmitter to full output.

It must be kept in mind that the two preceding adjustment procedures are to be used as a guide and will cover the majority of cases; however, cases may arise where conditions change. For example, if the adjustment is made per part a., the noise may increase due to various reasons such as bad insulators, which would require adjusting the receiver to be less sensitive. In the adjustment of part b., the attenuation may increase due to sleet or line switching, which would necessitate increasing the sensitivity of the receiver.

Reserve Signal Detector

Due to different types of operation and supply voltages, it is not practical to have a calibrated dial for this unit. However, calibration may be made at installation by recording transmitter output (either in db or volts) at various knob settings of the detector unit. Then, by adjusting the knob so as to obtain 10 milliamperes relay current at a remote receiver, any increase or decrease in line attenuation may be noted as the difference between the original setting, and the setting required to obtain the given 10 milliamperes.

250-Volt Resistor Unit

With the apparatus energized, adjust R-4 in the 250-volt resistor unit so as to obtain 125-volts at terminals 17 (B-) and 19 (B+) on the relaying set.

Frequency Change

If the frequency is changed in the field, it is necessary to change the input filter FL-1 to the desired channel frequency. This filter is of the plug-in type and may be removed by unsnapping the clamp and pulling the filter out. The transmitter oscillator crystal Y-2 must be changed to the desired channel frequency. The receiver oscillator crystal Y-1 must be changed to the desired channel frequency plus 20 kc. Figure 9 shows the connections for the transmitter output filter. It is necessary to unsolder the existing connections and make the new connections per the chart. After completing the preceding, the tuning procedure as described under Adjustments for transmitter and receiver should then be followed.

Note also that capacitors C2 and C9 in the transmitter and receiver crystal oscillator circuits, respectively, may have to be changed. For fre-

quencies below 110 kc, these capacitors are 270 mmf. each. For frequencies of 110 kc and above, the capacitors are 140 mmf. each.

CAUTION Turn power OFF before removing filters or transistors, as high transient currents may cause permanent damage to the transistors.

MAINTENANCE

Voltage values should be recorded after adjustment in order to establish reference values which will be useful when checking the apparatus. The readings will remain fairly constant over an indefinite period unless a failure occurs. However, if transistors are changed, there may be considerable difference in these readings without the overall performance being affected.

Typical voltage and current values are given as follows. Voltages should be measured with VTVM. Readings may vary as much as $\pm 20\%$.

In the following paragraphs, the transmitter may be unblocked (transmitting) by closing the CARRIER START circuit in the case of HZM relaying, and by opening the CARRIER START circuit in the case of K-DAR and GCY relaying.

1. For D-C pin jack measurements with reference to B-, refer to Table 1.

2. For transistor D-C measurements with reference to B-, refer to Table 2.

3. For D-C bleeder measurements with reference to B-, refer to Table 3.

4. For typical RF signal measurements for receiver, refer to Table 4.

5. For typical RF signal measurements for transmitter, refer to Table 5.

6. Removal of Printed Circuit Board from Flexitest Case.

To remove the printed circuit board, unplug J-15 and J-16 located near the output filter. Loosen the two screws inside the case near the top. Loosen the slotted thumb screws at the lower end of the board and pull these screws out as far as they will extend. Also remove the receiver coaxial cable plug.

Pull board down so as to disengage the terminals, and lift out.

7. Removal of the Output Filter

After the printed board has been removed, remove the screws on the outside of the case at the bottom. Lift out filter and disconnect the coaxial cable.

8. Receiver Filters

Fig. 15 shows typical receiver selectivity curves both RF and IF. If the filters are checked in a test setup, it is necessary to use an accurate signal generator or preferably a signal generator and a frequency counter.

9. Minimum Test Equipment for Installation

- a. Milliammeter 0-25 ma DC.
- b. 60-ohm 5-watt non-inductive resistor.
- c. A-C Vacuum Tube Voltmeter (VTVM). Voltage range 0.003 to 30 volts, frequency range 60 cycles/sec to 230-kc, input impedance 7.5 megohms.
- d. D-C Vacuum Tube Voltmeter (VTVM)

Voltage Range: 0.15 to 300 volts
Input Impedance: 7.5 megohms

10. Desirable Test Equipment for Apparatus Maintenance

- a. All items listed in Sections 8 and 9.
- b. Signal Generator

Output Voltage: up to 8 volts
Frequency Range: 20-kc to 230-kc
- c. Oscilloscope
- d. Ohmmeter
- e. Capacitor checker
- f. Test harness (See Fig. 17)

TABLE 1

D-C PIN JACK MEASUREMENTS WITH REFERENCE TO B-

Description	Jack	CONDITION A Tx-Blocked †† Rx-No Signal		CONDITION B Tx-Blocked Rx-With Signal		CONDITION C Tx-Unblocked Rx-No Signal	
		129 VDC	51 VDC	129 VDC	51 VDC	129 VDC	51 VDC
RF Input	J-2	0	0	0.3 V	0.3 V		
DC Q-1 Base	J-3	20 V	20 V	20 V	20 V		
DC R _x B+	J-4	20 V	20 V	20 V	20 V		
DC R _x Osc	J-5	7 V	7 V	7 V	7 V		
DC Q-5 Base	J-6	20 V	20 V	20 V	20 V		
B-	J-7						
DC-P1-E	J-8	110 V	32 V	110 V	32 V	110 V	32 V
DC-Q-7 Base	J-9	69 V	0 V	78 V	2.3 V	66 V	0.3 V
DC Q-7 Emit	J-10	70 V	1.0 V	78 V	1.4 V	66 V	1.0 V
DC T _x Osc	J-11	7 V	7 V	7 V	7 V	7 V	7 V
B+	J-12	129 V	51 V	129 V	51 V	129 V	51 V
DC Q-10 Base	J-13					18 V	18 V
DC Q-10 Emit	J-14					18 V	18 V
RF ma out	J-15					130 ma	130 ma
DC ma RRH and ALARM				18 ma	* 18 ma		

†† Tx = transmitter, Rx = receiver

TABLE 2

TYPICAL TRANSISTOR DC MEASUREMENTS WITH REFERENCE TO B-

Transistor	Condition A Tx-Blocked Rx-No Signal (Volts)			Condition B Tx-Blocked Rx-With Signal (Volts)			Condition C Tx-Unblocked Rx-No Signal (Volts)		
	E†	B†	C†	E†	B†	C†	E†	B†	C†
Q-1	20.0	20.0	0.38	20.0	20.0	0.4			
Q-2	7	7.2	1.8	7	7.2	1.8			
Q-3	6.2	8.0	2	6.2	8	2.0			
Q-4	20.0	20.0	2.6	20.0	20.0	2.8			
Q-5	20.0	20.0	2.6	20.0	20.0	2.8			
Q-6									
129 VDC	110	110	129	115	114	129			
51 VDC	32	32	51	32	32	51			
Q-7									
129 VDC	70	68	129	78	80	86			
51 VDC	1.0	0	51	1.4	2.2	7.0			
Q-8	6.2	8	2	6.2	8	2	6.2	8	2
Q-9	7	7.2	1.8	7	7.2	1.8	7	7.2	1.8
Q-10††							18	18	0.4
Q-12††							0.27	0.20	50
Q-15††							0.27	0.20	50

† E-Emitter; B-Base; C-Collector.

†† With respect to term F on printed board.

TABLE 3

D-C BLEEDER MEASUREMENTS WITH REFERENCE TO B-

Measurement	129 VDC			51 VDC		
	A†	B†	C†	A†	B†	C†
Junction R-61 and R-62 (J-8)	110V	110V	110V	32V	32V	32V
Junction R-61 and R-27 (J-10)	70V	78V	66V	1.0V	1.4V	1.0V
Junction R-27 and R-60 (P1-P)	69V	77V	65V	0	0	0
Junction CR-8 and R-64 (P1-K)	58V	58V	58V	51V	51V	51V
Junction R-48 and R-47 (J-14)	—	—	18V	—	—	18V
Junction R-45 and R-47 (TP-9)	—	—	45V	—	—	51V
Junction R-45 and R-41 (TP-8)	—	—	98V	—	—	51V

†Conditions: A — Tx-Blocked, Rx-No Signal; B — Tx-Blocked, Rx-With Signal; C — Tx-Unblocked, Rx-No Signal.

TABLE 4
TYPICAL RF SIGNAL MEASUREMENTS FOR RECEIVER
(Made with 0.1 Volt at Terminal 5 of FL1)

Check Point	25 MV Sensitivity (Volts)	80 MV Sensitivity (Volts)	250 MV Sensitivity (Volts)
With Receiver Crystal Out			
FL1-5 to Gnd.	0.1	0.1	0.1
T1-1 to Gnd.	0.1	0.1	0.1
Q1-E to Gnd.	0.05	0.05	0.05
Q1-C to Gnd.	0.07	0.07	0.07
T3-1 to Gnd.	0.07	0.07	0.07
Q4-C to Gnd.	0.07	0.07	0.07
With Receiver Crystal In			
Q4-C to Gnd.	0.5	0.5	0.25
J6 to Gnd.	0.15	0.1	0.08
Q5-C to Gnd.	7.0	1.7	0.8
Q6-B to Gnd.	2.0	0.5	0.4
Q6-C to Gnd.	13.0	10.0	8.0
T4-1 to Gnd.	13.0	10.0	8.0
T4-3 to T4-4	4.5	3.5	2.5
J9 to J10 (DC)	0.74	0.75	0.65

TABLE 5

TYPICAL RF SIGNAL MEASUREMENTS FOR TRANSMITTER	
CHECK POINT	VOLTS
T5-1 to Gnd.	5.5
T5-3 to Gnd.	1.0
J13 to Gnd.	0.085
Q10-C to Gnd.	6.0
T6-2 to Gnd.	6.0
Q12-B to Gnd.	0.8
Q15-B to Gnd.	0.8
Q12-C to Gnd.	38.0
Q15-C to Gnd.	38.0
T7-5 to Gnd.	9.8
Output to Gnd.	8.0

APPLICATION

1. Receiver Selectivity (Fig. 14)

This shows a typical curve of the overall selectivity of the receiver under steady state conditions.

2. Transmitter Output Selectivity (Fig. 10)

Typical curves are shown so that approximate bandwidths for keying purposes can be determined for any carrier frequency between 30-kc and 200-kc.

3. Minimum Channel Spacing (Fig. 16)

This is a graph from which minimum channel spacing can be obtained provided the signal strength of the interfering transmitter and the sensitivity setting of the receiver are known. These can be obtained from calculations or by measurements.

For example, if the interfering transmitter voltage is measured (at the receiver) and found to be 2.5

volts, this would be 10-db down from 8 volts. This point can be located on the right hand column of the graph. Then, if the receiver sensitivity were set to operate on 0.8 volts or 20-db, this point would be located on the left hand column. A line could then be drawn through the two points as shown by the dotted line. The intersection of this line with the center line indicates the minimum channel spacing. In this case if the interfering signal is being keyed on-off, at 15 pps, the minimum spacing would be 2.5-kc.

4. Transmitter Output and Receiver Sensitivity Variations with Voltage (Fig. 12)

These curves show the variation of transmitter output and receiver sensitivity with changes in supply voltage, at 120-kc and 25°C. The increase and decrease in transmitter output above or below 1.0 watts may be obtained in db from the transmitter curve. 1.0 watts is about 8.0 volts with a 60-ohm load.

The increase and decrease in receiver sensitivity above or below 40 millivolts can similarly be

TYPE KR CARRIER SET

obtained in db from the receiver curve. 40 millivolts sensitivity represents the input signal required for proper operation.

5. Transmitter Output and Receiver Sensitivity Variations with Frequency (Fig. 13)

These curves show the variation of transmitter output and receiver sensitivity with variation in frequency, at a supply voltage of 129 VDC, and 25°C. They may be used in the same manner as Fig. 12.

6. Supervisory Control Connections (Fig. 7)

When supervisory control is used with relaying, the supervisory control relay coil is connected in

series with the RRH coil in place of the alarm relay. When supervisory control is used alone, a 1200-ohm resistor R3 is connected in series with the control relay coil by removing the jumper across R3, as shown in Fig. 7. In order to maintain proper mark space ratio, the relay bias current is adjusted for 9 milliamperes as indicated.

The receiver RF filter and the IF filter limits are shown on Fig. 15. Both filters are of the plug-in type and the test circuits with pin connections are shown at the top of each curve. The IF filter is divided into two separate sections. The selectivity shown is for each section, and the pin connections for each section are also shown in the test circuit sketch.

ELECTRICAL PARTS LIST

CIRCUIT SYMBOL	FUNCTION	DESCRIPTION	MFR. CODE	MANUFACTURER'S DESIGNATION
<u>CAPACITORS</u>				
C-1	Rcvr. Bleeder	2.0 μ f, \pm 20%, 200 VDC, Paper	1	330C567 H11
†C-2	Rcvr. Osc. Feedback	140/270 μ f, \pm 20%, 500 VDC, Mica	1	330C566 H43 or 330C566 H57
C-3	Rcvr. Osc. Bleeder Bypass	0.02 μ f, MRC, 600 VDC, Disc	1	330C569 H47
C-5	Q-6 Emitter Bypass	1.0 μ f, \pm 20%, 200 VDC Paper	1	330C567 H09
C-6	Rcvr. Rectifier Bypass	Same as C-5		
C-7	B- to B+ Bypass	2 μ f, \pm 10%, 600 VDC, Paper	1	14C9400 H18
C-8	B- to GND	1.0 μ f, \pm 10%, 1000 VDC, Paper	1	14C9400 H17
†C-9	Xmtr. Osc. Feedback	Same as C-2		
C-10	Xmtr. Osc.	Same as C-3		
C-11	Key Filter	0.1 μ f, \pm 20%, 200 VDC, Paper	1	330C567 H02
C-12	Q-10 Emitter Bypass	0.25 μ f, \pm 20%, 200 VDC, Paper	1	330C567 H05
C-13	Q-10 Bleeder Bypass	Same as C-12		
C-14	PA Base Bypass	Same as C-12		

†Note: 140 μ f for osc. freq. 110-kc and above.
270 μ f for osc. freq. below 110-kc.

ELECTRICAL PARTS LIST

CIRCUIT SYMBOL	FUNCTION	DESCRIPTION	MFR. CODE	MANUFACTURER'S DESIGNATION
		<u>CAPACITORS (Concluded)</u>		
C-18	PA Bleeder	0.5 μ f, \pm 20%, Paper	1	330C567 H06
C-19	Output Filter Tuning	500 μ f, Variable, Air	1	328C092 H01
C-20	Output Filter	390 μ f, \pm 5%, 2500 VDC, Mica	1	330C561 H15
C-21	Output Filter	680 μ f, \pm 5%, 2500 VDC, Mica	1	330C561 H21
C-22	Output Filter	1200 μ f, \pm 5%, 2500 VDC, Mica	1	330C561 H27
C-24	FL-2 Decoupling	Same as C-12		
C-25	Q-7 Emitter	12 mfd, \pm 20%, 200 VDC	1	187A177 H01
		<u>CRYSTAL DIODES</u>		
CR-1	Bridge Rectifier	General Purpose, IN63	1	584C433 H02
CR-2	Bridge Rectifier	Same as CR-1		
CR-3	Bridge Rectifier	Same as CR-1		
CR-4	Bridge Rectifier	Same as CR-1		
CR-5	Q-10 Collector	Same as CR-1		
CR-6	*Q-7 Base-Emitter	*Type IN4574		
CR-7	Voltage Regulator	Type 1N768,	1	584C434 H02
CR-8	Voltage Regulator	Type 1N1369	1	584C434 H05
CR-9	Q-7 Collector	*Type IN3811	1	*185A089H08

ELECTRICAL PARTS LIST

CIRCUIT SYMBOL	FUNCTION	DESCRIPTION	MFR. CODE	MANUFACTURER'S DESIGNATION
<u>FUSE HOLDERS</u>				
FH-1	B-	For Type 3AGC Fuses	1	584C271 H02
FH-2	B+	Same as FH-1		
<u>FUSES</u>				
F-1	B-	3AGC 3/4 amp.	1	S#330C691 H12
F-2	B+	Same as F-1		
<u>FILTERS</u>				
FL-1	Rcvr. RF Bandpass	* 30 to 200 kc Freq. to be specified by customer	1 1 1	
FL-2	Rcvr. IF Bandpass	20-kc Fixed Freq.	1	
<u>CONNECTORS</u>				
J-1	Printed Circuit	Printed Circuit Female Plug	1	54-B-7125 H03
J-2	RF Input	UG-185-U	1	584C292 H07
J-3	Rcvr. Osc. Output	Terminal Studs	1	330C592 H01
J-4	Rcvr. Mixer-Amp Supply	Same as J-3		
J-5	Rcvr. Osc. Supply	Same as J-3		
J-6	Q-5 Base	Same as J-3		
J-7	B-	Same as J-3		
J-8	Q-6 Supply	Same as J-3		

ELECTRICAL PARTS LIST

CIRCUIT SYMBOL	FUNCTION	DESCRIPTION	MFR. CODE	MANUFACTURER'S DESIGNATION
<u>CONNECTORS (Concluded)</u>				
J-9	Q-7 Base	Same as J-3		
J-10	Q-7 Emitter	Same as J-3		
J-11	Xmtr. Osc. Supply	Same as J-3		
J-12	B+	Same as J-3		
J-13	Xmtr. Osc. Output	Same as J-3		
J-14	Q-10 Supply	Same as J-3		
J-15	Output Filter	Banana Tip Red	1	328C093 H01
J-16	Output Filter GND	Banana Tip Black	1	328C093 H02
P-1	Printed Circuit	Printed Circuit Male Plug	1	54-B-7126 H03
<u>INDUCTORS</u>				
L-1	Core and Coil Assembly	11 MH Total – 6 MH Tap (Part of FL-3)	1	329C450
L-2	Core and Coil Assembly	2.5 MH (Part of FL-3)	1	329C449
L-3	RF Choke	1.0 MH, 300 ma	2	R-300
L-4	RF Choke	Same as L-3		
<u>TRANSISTORS</u>				
Q-1	Rcvr. Mixer	*Type 2N525	1	*184A638H13
Q-2	Rcvr. Osc.	Type 2N414	1	* 184A638H14

ELECTRICAL PARTS LIST

CIRCUIT SYMBOL	FUNCTION	DESCRIPTION	MFR. CODE	MANUFACTURER'S DESIGNATION
		<u>TRANSISTORS (Concluded)</u>		
Q-3	Rcvr. Osc.	Same as Q-2		
Q-4	Rcvr. IF	Same as Q-1		
Q-5	Rcvr. IF	Same as Q-1		
Q-6	Rcvr. IF	* Type 2N657	1	* 184A638H15
Q-7	Rcvr. Output	* Type 2N698	1	* 762A585H02
Q-8	Xmtr. Osc.	Same as Q-2		
Q-9	Xmtr. Osc.	Same as Q-2		
Q-10	Xmtr. Amp.	Same as Q-1		
Q-12	Xmtr. PA	Type 2N498	1	330C587 H12
Q-15	Xmtr. PA	Same as Q-12		
		<u>RESISTORS</u>		
R-1	Rec. Input	25 K, $\pm 20\%$, 1/4 W, Pot.	1	584C276 H23
R-2	Filter Matching	10 K, $\pm 10\%$, 1/2 W	1	330C595 H37
R-3	Filter Load	Same as R-2		
R-4	Rcvr. Osc.	1 K, $\pm 20\%$, 1/4 W, Pot.	1	584C276 H19
R-5	Rcvr. Voltage Divider	6.2 K, $\pm 5\%$, 1 W	1	330C666 H68
R-6	Q-2 Collector	1.2 K, $\pm 5\%$, 1/2 W	1	330C664 H51
R-8	Rcvr. Voltage Divider	30 K, $\pm 5\%$, 2 W	1	330C668 H84
R-9	Rcvr. Voltage Divider	Same as R-8		

ELECTRICAL PARTS LIST

CIRCUIT SYMBOL	FUNCTION	DESCRIPTION	MFR. CODE	MANUFACTURER'S DESIGNATION
		<u>RESISTORS (Continued)</u>		
R-10	Q-2 Base	Same as R-2		
R-11	Q-2 Base	100 K, $\pm 5\%$, 1/2 W	1	330C665 H05
R-12	Q-3 Collector	Same as R-6		
R-13	Q-3 Emitter	390 Ohms, $\pm 5\%$, 1/2 W	1	330C664 H39
R-14	Q-3 Base	Same as R-2		
R-15	Q-3 Base	Same as R-11		
R-16	Rcvr. Osc. Bleeder	2.2 K, $\pm 10\%$, 1/2 W	1	330C595 H41
R-17	Rcvr. Osc. Bleeder	18 K, $\pm 10\%$, 2 W	1	330C597 H40
R-18	Rcvr. Osc.	9.1 K, $\pm 5\%$, 1/2 W	1	330C664 H72
R-19	Q-4 Bias	100 Ohms, $\pm 5\%$, 1/2 W	1	330C664 H25
R-20	Q-4 Bias	Same as R-2		
R-21	Q-5 Bias	150 Ohms, $\pm 5\%$, 1/2W	1	330C664 H29
R-22	Q-5 Bias	Same as R-2		
R-23	Q-6 Bias	330 Ohms, $\pm 5\%$, 1/2 W	1	330C664 H37
R-24	Q-6 Bias	Same as R-2		
R-25	Q-6 Emitter	Same as R-19		
R-26	Q-7 Base	Same as R-6		
R-27	Q-7 Bias	20 Ohms, $\pm 5\%$, 1/2 W	1	330C664 H08
R-28	Xmtr. Osc. Bleeder	Same as R-18		
R-29	Xmtr. Osc. Bleeder	Same as R-17		
R-30	Xmtr. Osc. Bleeder	Same as R-16		

ELECTRICAL PARTS LIST

CIRCUIT SYMBOL	FUNCTION	DESCRIPTION	MFR. CODE	MANUFACTURER'S DESIGNATION
<u>RESISTORS (Continued)</u>				
R-31	Q-8 Base	Same as R-11		
R-32	Q-8 Base	Same as R-2		
R-33	Q-8 Emitter	Same as R-13		
R-34	Q-8 Collector	Same as R-6		
R-35	Q-9 Base	Same as R-11		
R-36	Q-9 Base	Same as R-2		
R-37	Q-9 Collector	Same as R-6		
R-38	Key Filter	Same as R-23		
R-39	Buffer Voltage Divider	36 K, $\pm 5\%$, 2 W	1	330C668 H86
R-40	Buffer Voltage Divider	Same as R-39		
R-41	Buffer Voltage Divider	Same as R-2		
R-42	Xmtr. Osc. Output	Same as R-4		
R-43	Q-10 Bias	Same as R-23		
R-44	Q-10 Bias	33 K, $\pm 5\%$, 1/2 W	1	330C664 H85
R-45	Buffer Voltage Divider	15 K, $\pm 10\%$, 1 W	1	330C596 H39
R-47	Buffer Voltage Divider	6.8 K, $\pm 5\%$, 1/2 W	1	330C664 H69
R-48	Buffer Voltage Divider	15 K, $\pm 5\%$, 1/2 W		330C664 H77
R-49	PA Bias	27 K, $\pm 5\%$, 2 W	1	330C668 H83

ELECTRICAL PARTS LIST

CIRCUIT SYMBOL	FUNCTION	DESCRIPTION	MFR. CODE	MANUFACTURER'S DESIGNATION
		<u>RESISTORS (Concluded)</u>		
R-50	Xmtr. PA	Same as R-19		
R-52	Q-12 Emitter	10 Ohms, $\pm 5\%$, 1/2 W	1	330C664 H01
R-55	Q-15 Emitter	Same as R-52		
R-59	Xmtr. Bleeder	47 Ohms, $\pm 10\%$, 1/2 W	1	330C595 H09
R-60	Recvr. Bleeder	1 K, $\pm 5\%$, 25 W	1	584C416 H57
R-61	Recvr. Bleeder	600 Ohms, $\pm 5\%$, 25 W	1	584C416 H47
R-62	Recvr. Bleeder	350 Ohms, $\pm 5\%$, 25 W	1	584C416 H52
R-64	Xmtr. Bleeder	1200 Ohms, $\pm 5\%$, 25 W	1	584C416 H64
R-66	T-7 Load	560 Ohms, $\pm 5\%$, 2 W	1	330C668 H43
R-67	Xmtr. Blocking	10 Ohms, $\pm 5\%$, 2 W	1	330C668 H01
R-68	Xmtr. Blocking	10 K, $\pm 10\%$, 10 W	1	330C577 H01
R-69	Q-10 Emitter	Same as R-19		
R-70	FL2 Decoupling	470 Ohms, $\pm 10\%$, 1/2 W	1	330C595 H21
R-71	Q-4 Emitter	150 Ohms, $\pm 10\%$, 1/2 W	1	330C595 H15
R-72	Q-5 Emitter	68 Ohms, $\pm 10\%$, 1/2 W	1	330C595 H11
R-73	Q-5 Base	180 Ohms, $\pm 10\%$, 1/2 W	1	330C595 H16
R-74	Q-4 Base	2.7 K, $\pm 5\%$, 1/2 W	1	330C664 H59
R-75	Q-4 Collector	22 K, $\pm 10\%$, 1/2 W	1	330C595 H41
R-76	Q-5 Collector	Same as R-75		

ELECTRICAL PARTS LIST

CIRCUIT SYMBOL	FUNCTION	DESCRIPTION	MFR. CODE	MANUFACTURER'S DESIGNATION
<u>TRANSFORMERS</u>				
T-1	Rcvr. Input	Impedance Ratio 10 K; 10K	1	S#1962798, L-633005
T-2	Rcvr. Osc.	Impedance Ratio 10 K: 400 ohms	1	S#1962797, L-633003
T-3	Rcvr. Mixer	Impedance Ratio 25 K: 300 ohms	1	S#1962697, L-592171
T-4	IF Output	Impedance Ratio 4 K: 500 ohms	1	S#1962693, L-592289
T-5	Xmtr. Osc.	Same as T-2		
T-6	Xmtr. Buffer	Impedance Ratio 10 K: 400 ohms CT	1	S#1962698, L-592170
T-7	Xmtr. Output	Impedance Ratio 1930: 60	1	S#1962694, L-633000
<u>TEST POINTS</u>				
TP-1	R-5	Terminal studs	1	330C592 H02
TP-2	R-8	Same as TP-1		
TP-3	R-17	Same as TP-1		
TP-4	R-18	Same as TP-1		
TP-5	R-28	Same as TP-1		
TP-6	R-39 & R-40	Same as TP-1		
TP-7	R-41	Same as TP-1		
TP-8	R-45	Same as TP-1		
TP-9	R-47	Same as TP-1		

ELECTRICAL PARTS LIST

CIRCUIT SYMBOL	FUNCTION	DESCRIPTION	MFR. CODE	MANUFACTURER'S DESIGNATION
		<u>SOCKETS</u>		
X-1	FL-1	Octal	1	330C689 H01
X-2	FL-2	Same as X-1		
X-4	Rear Mounted Voice Adaptor	Same as X-1		
XY-1	Rec. Y-1	Crystal	1	584C606 H01
XY-2	Xmtr. Y-2	Same as XY-1		
		<u>CRYSTALS</u>		
Y-1	Rcvr. Osc.	Specify Channel Freq. Plus 20-kc	1	328C083
Y-2	Xmtr. Osc.	Specify Freq. Same as Channel Frequency	1	328C083
		<u>RESERVE SIGNAL DETECTOR</u> (S#470D167G02)		
R-1	Resistor, Level Control	100 K, 2 W, Pot.	1	51-D-1976 H17 (S#1475074)
R-2	Resistor, Limiting	2000 ohms, 2" tube.	1	1267296
S-1	Test Switch	SPST Normally Open	1	327C854 H01

LIST OF MANUFACTURERS

1. Westinghouse Electric Corporation
2. National Co., Inc., Malden, Mass.

TYPE KR CARRIER SET

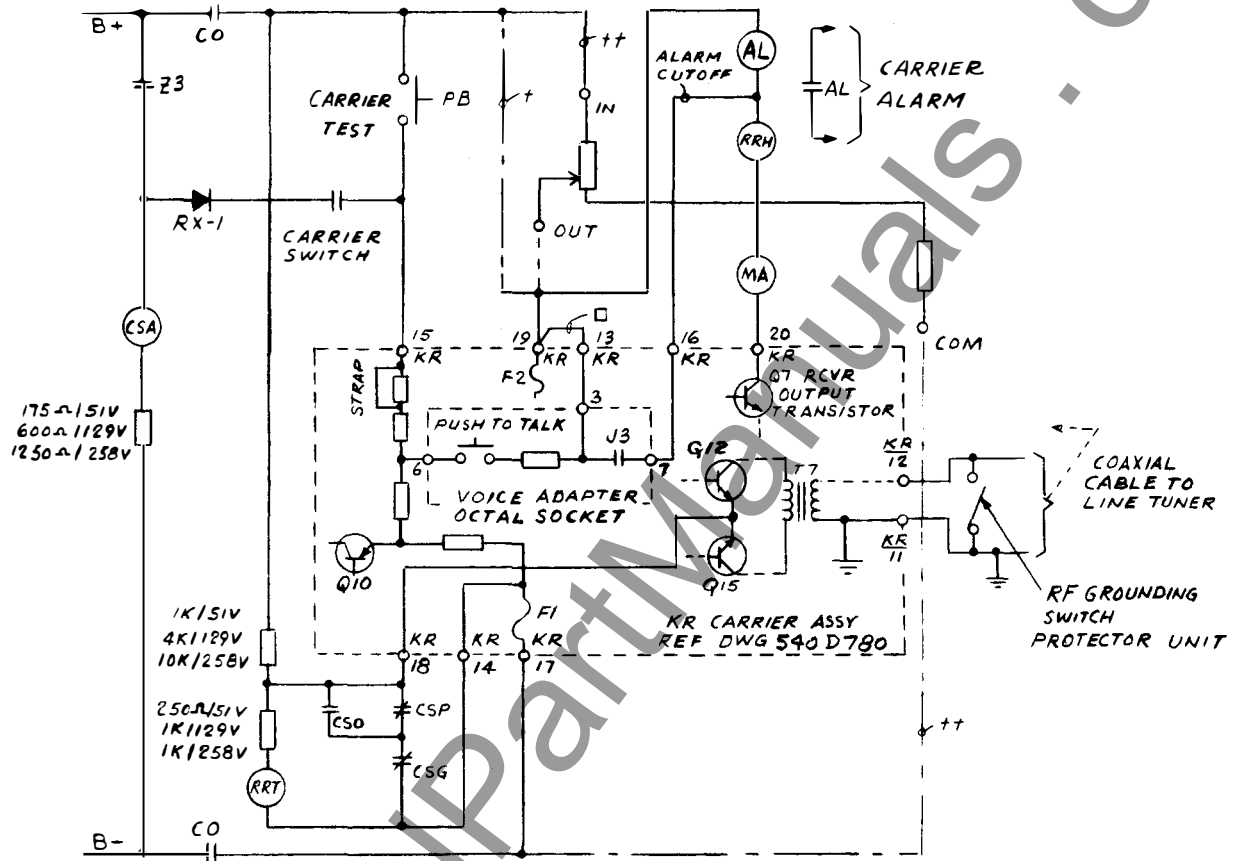

REQUIREMENTS FOR HZ/HZM RELAYING

SUPPLY VOLTAGE	CARRIER START	CARRIER STOP	STRAP
51VDC	+51V, 7MA	+28V	IN
129VDC	+129V, 8MA	+40V	IN
258VDC	+258V, 8MA	+40V	OUT

- NOTES
- + FOR 51 & 129 VDC SUPPLY.
 - ++ FOR 258VDC SUPPLY USE 330C191H01 RESISTOR UNIT REF DWG 223B497
 - FOR SUPERVISORY CONTROL PREFERENCE CONTACTS.

- KR RELAYING TRANSMITTER / RECV EXTERNAL CONNECTIONS
- TERMINAL - CONNECTION
11. GROUND
 12. COAXIAL CABLE
 13. SUPERVISORY PREFERENCE CONTACT
 14. CARRIER STOP B- RETURN
 15. CARRIER START (POSITIVE)
 16. ALARM CUTOFF FOR COMMUNICATIONS
 17. B MINUS
 18. CARRIER STOP (HZ/HZM)
 19. B PLUS
 20. RELAY COIL

* Fig. 3- Relaying Control Circuits - HZ/HZM (Dwg. 1-329C704)

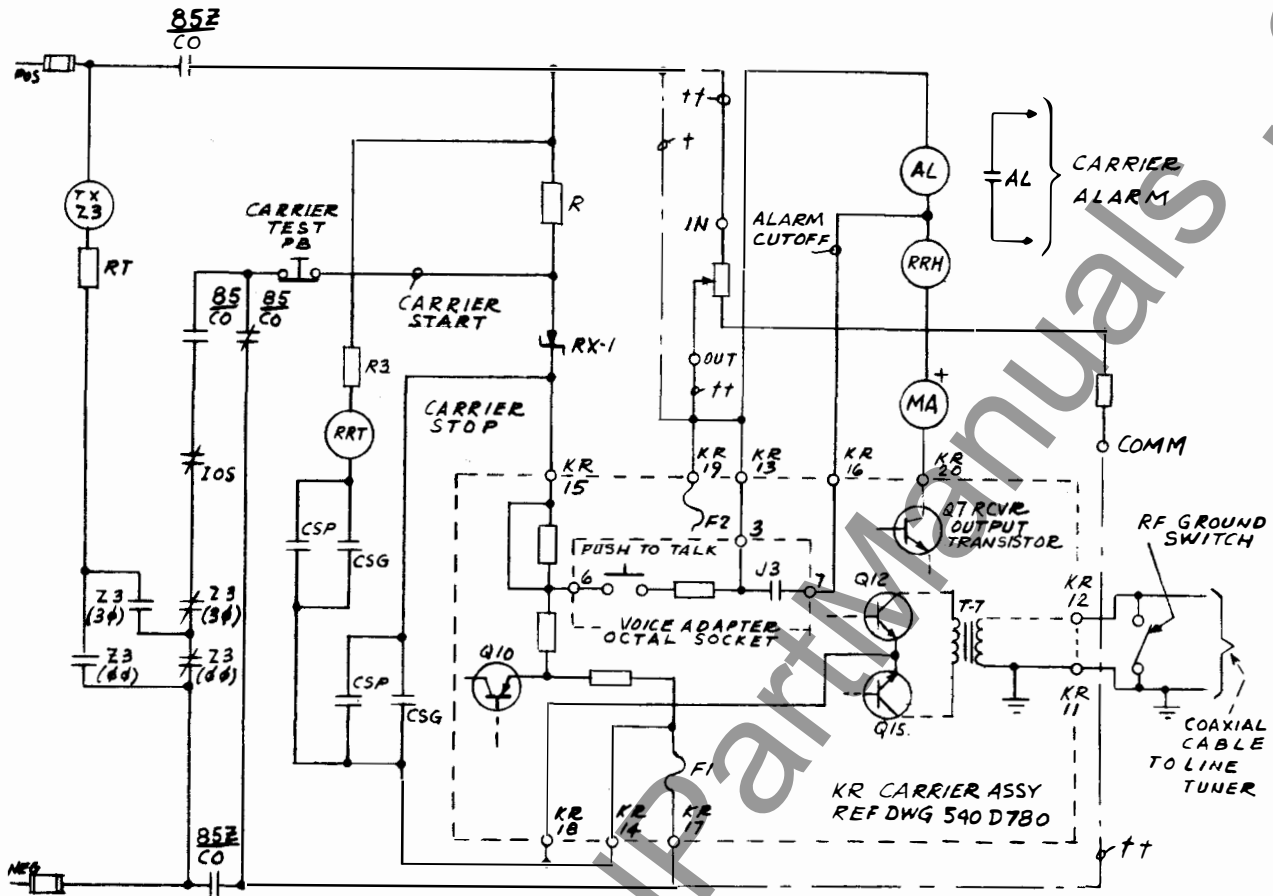

REQUIREMENTS FOR K-DAR RELAYING

SUPPLY VOLTAGE	CARRIER START	CARRIER STOP	R
51 VDC	+ 37V, 7MA	0 VOLTS	2K
129 VDC	+100V 8MA	0 VOLTS	3.75K
258 VDC	+100V 8MA	0 VOLTS	19K

NOTES

**KR RELAYING TRANSMITTER /
RECV. EXTERNAL CONNECTIONS**

TERMINAL CONNECTION

- 11 GROUND
- 12 COAXIAL CABLE
- 13 SUPERVISORY PREFERENCE CONTACT
- 14 CARRIER STOP B- RETURN
- 15 CARRIER START (POSITIVE)
- 16 ALARM CUTOFF FOR COMMUNICATIONS
- 17 B MINUS
- 18 CARRIER STOP (HZ/HZM)
- 19 B PLUS
- 20 RELAY COIL

- + FOR 51 & 129 VDC SUPPLY
- ++ FOR 258VDC SUPPLY USE
330C191H01 RESISTOR UNIT
REF DWG 223B497

* Fig. 4-Relaying Control Circuits-K-Dar (Dwg. 3-329C704)

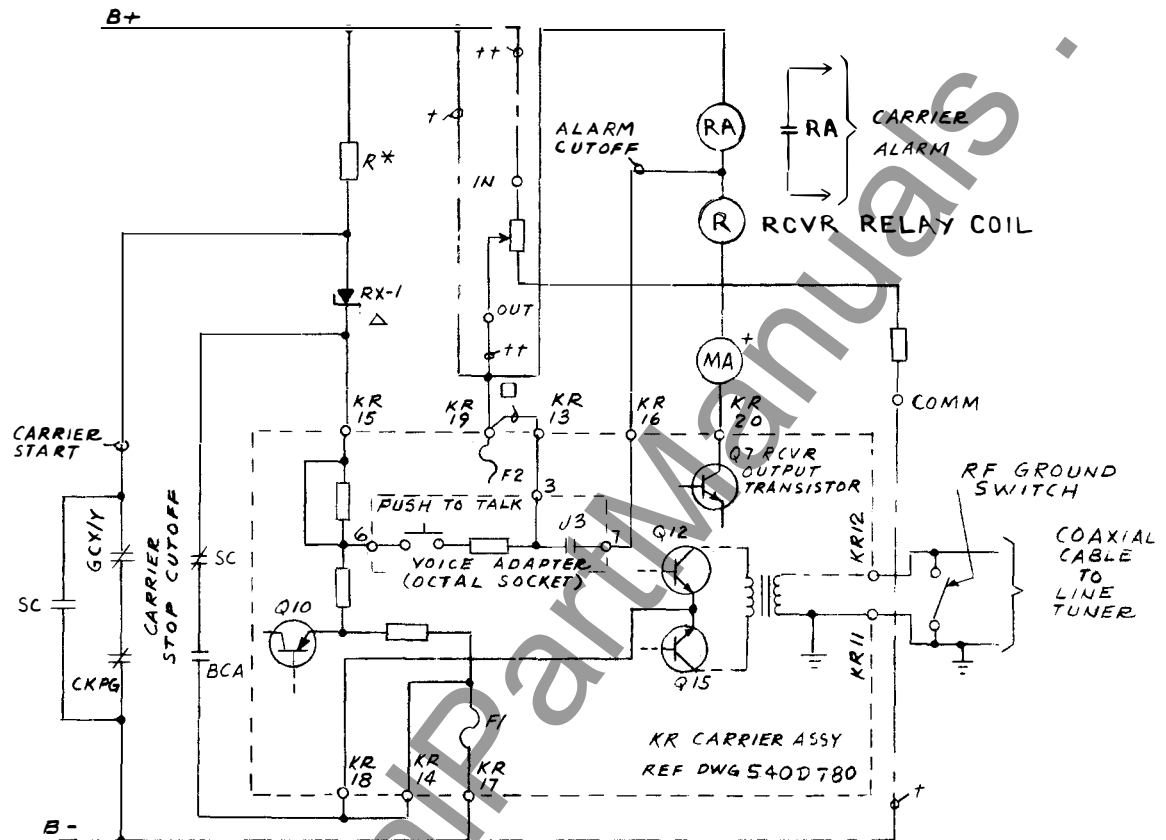

REQUIREMENTS FOR GCX/GCY RELAYING

SUPPLY VOLTAGE	CARRIER START	CARRIER STOP	R
51 VDC	+37V, 7MA	0 VOLTS	2K
129 VDC	+100V, 8MA	0 VOLTS	3.75K
258 VDC	+100V, 8MA	0 VOLTS	19.K

KR RELAYING TRANSMITTER /
RECV. EXTERNAL CONNECTIONS
TERMINAL CONNECTION

- 11. GROUND
- 12. COAXIAL CABLE
- 13. SUPERVISORY PREFERENCE CONTACT
- 14. CARRIER STOP B- RETURN
- 15. CARRIER START (POSITIVE)
- 16. ALARM CUTOFF FOR COMMUNICATIONS
- 17. B MINUS
- 18. CARRIER STOP (HZ/HZM)
- 19. B PLUS
- 20. RELAY COIL

NOTES

- * FOR 'R' USE OHMITE VITREOUS ENAMELED DIVIDOHM ADJUSTABLE 4K OR 20K 25W RESISTOR, CONNECT & ADJUST FOR VALUES SHOWN
- Δ TYPE IN 3051
- + FOR 51 & 129 VDC SUPPLY
- ++ FOR 258VDC SUPPLY USE 330C191H01 RESISTOR UNIT REF DWG 223B497
- FOR SUPERVISORY CONTROL PREFERENCE CONTACTS

Fig. 5. Relaying Control Circuits - GCX/GCY (Dwg. 2-329C704)

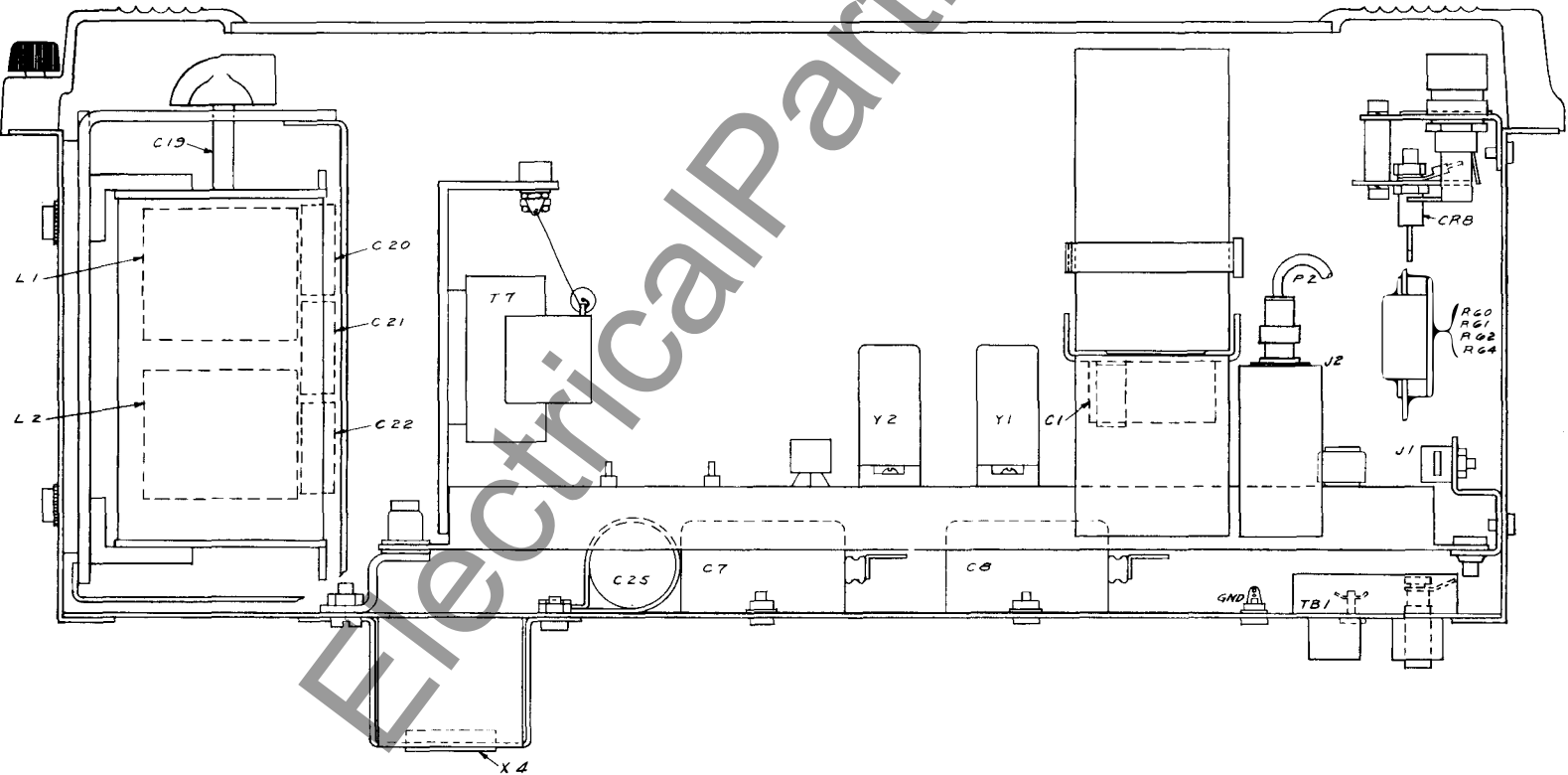
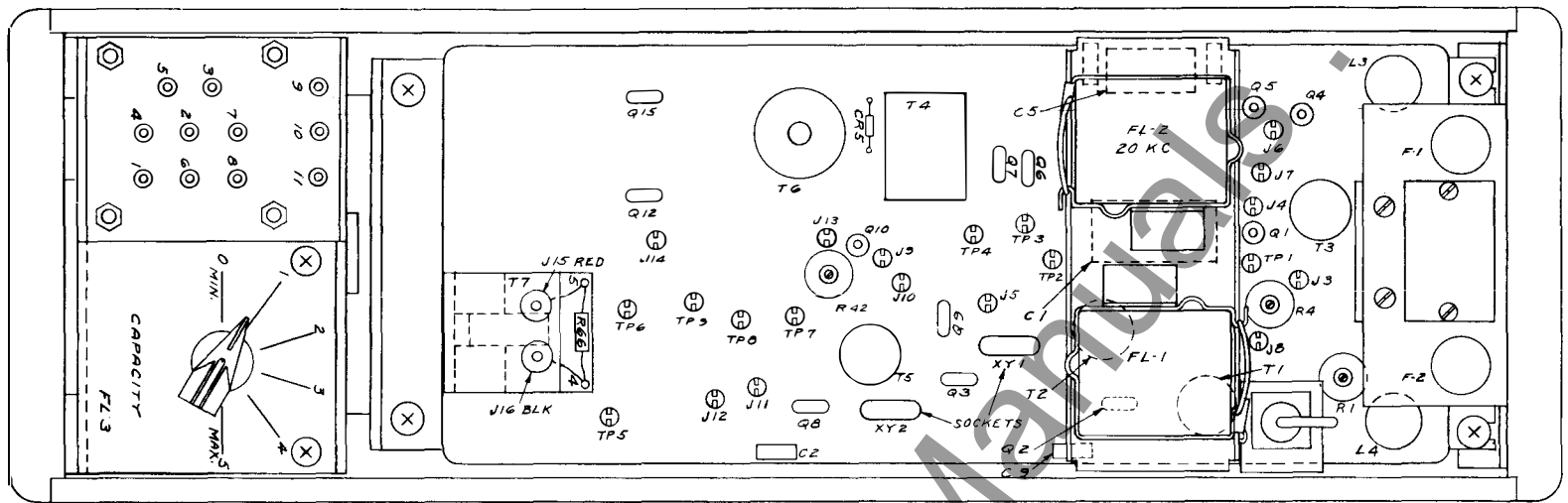
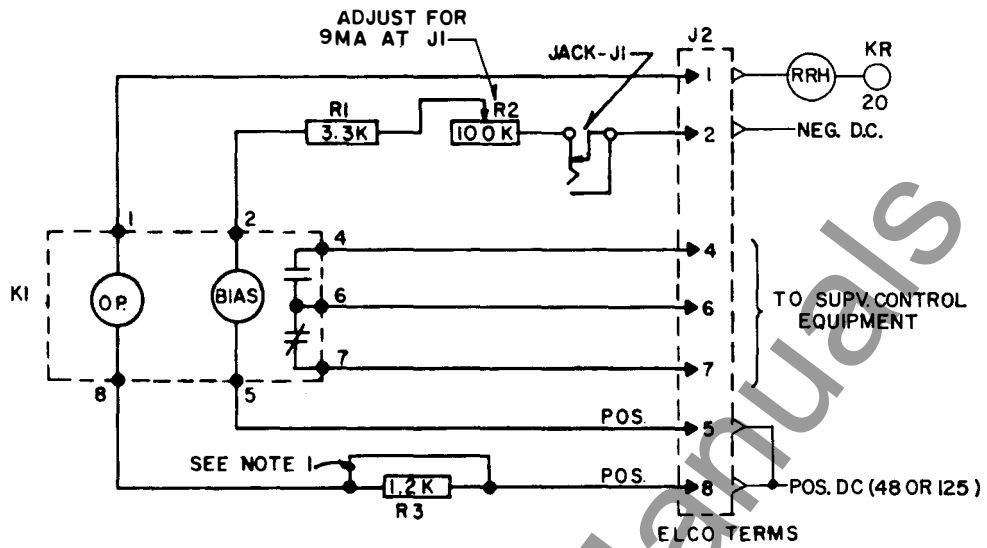

Fig. 6. Component Location (Dwg. 540D781)



- NOTES:
1. REMOVE FOR KR CARRIER PLUS SUPV. CONTROL WITHOUT RELAYING.
 2. POLARITY SHOWN CLOSES CONTACT BETWEEN TERMINALS 4 & 6.

J 2

1	2	3	4
5	6	7	8

AS VIEWED FROM REAR OF PANEL

629A552

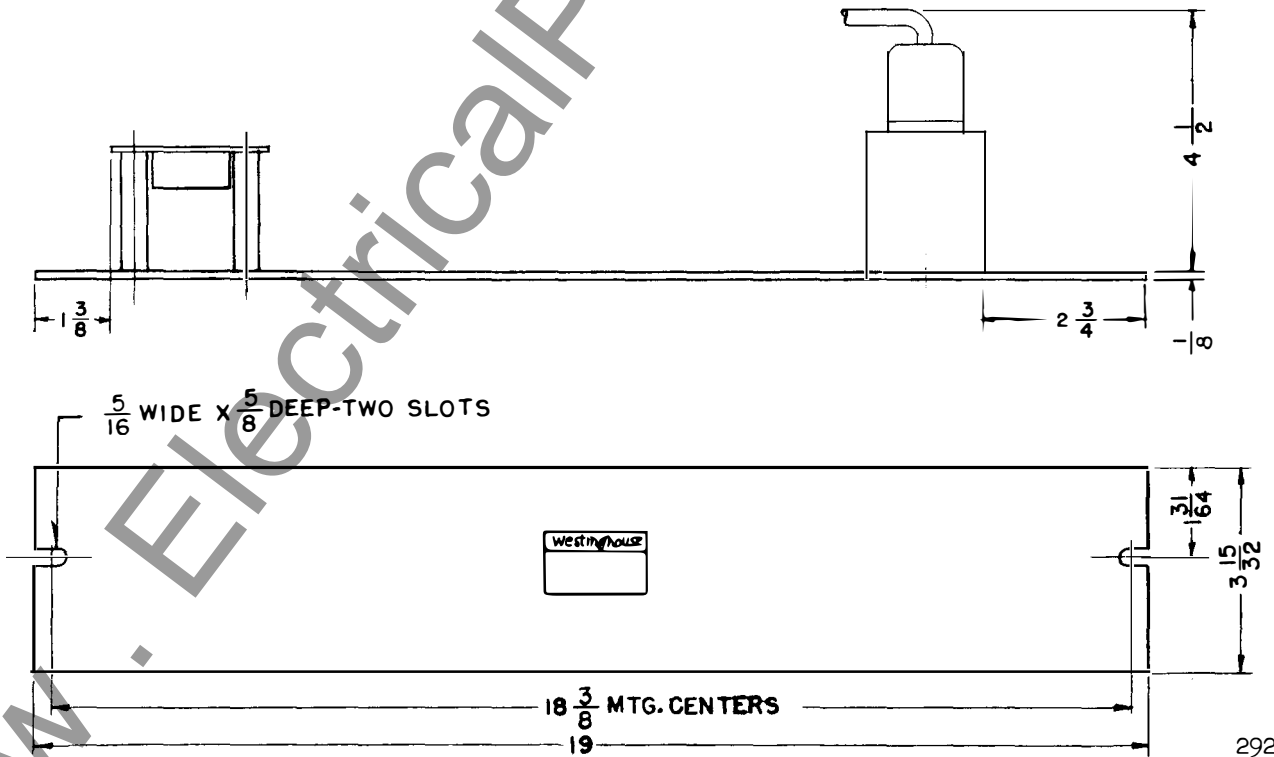

292B991

Fig. 7. Supervisory Control Auxiliary Relay Connections (Dwg. 629A552) and Outline (Dwg. 292B991).

**CONNECTIONS FOR 48-250 VOLT SERVICE AND
SUPERVISORY CONTROL APPLICATION**
(CHANGES FROM JUMPERS SHOWN ON INTERNAL SCHEMATIC, FIG.2)

250-VOLT OPERATION

FOR A 250 VOLT SUPPLY, RESISTOR UNIT 330C191H01 IS USED AS SHOWN ON APPLICATION DRAWING 329C704

FOR HZ/HZM OPERATION, THE JUMPER HAS BEEN REMOVED FROM TP-6 TO TP-7. (NOT REMOVED FOR K-DAR RELAYING).

RESISTOR UNIT SCHEMATIC:

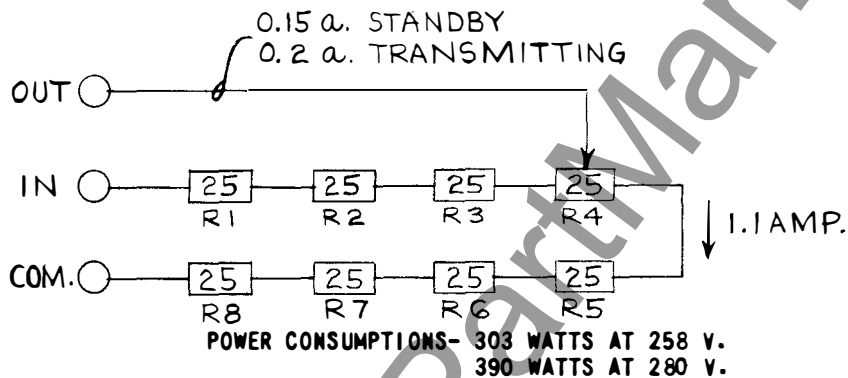

NOTE: KR SUPPLY VOLTAGE WILL BE APPROXIMATELY 144 VOLTS UNDER STANDBY CONDITION WHEN BATTERY VOLTAGE IS 280 VOLTS.

125-VOLT HZ/HZM OPERATION

JUMPER TP-7 AND TP-8 IS REMOVED.

48 VOLT OPERATION

ON PRINTED CIRCUIT BOARD ADDITIONAL JUMPERS ARE CONNECTED AS FOLLOWS:

- BETWEEN TP8 AND TP9
- BETWEEN TP5 AND J12
- BETWEEN TP1 AND TP2
- BETWEEN TP3 AND TP4

IN THE FT CASE, JUMPERS ARE CONNECTED ACROSS R60 AND R64, AND THE CONNECTION BETWEEN R64 AND DIODE CR8 IS REMOVED.

IN ADDITION, FOR 48-VOLT SUPERVISORY CONTROL, R59 IS CONNECTED INTO THE CIRCUIT.

Fig. 8. Connections, 48-250 Volts and Supervisory Control (Dwg. 407C971)

TRANSMITTER OUTPUT FILTER FL-3 CONNECTIONS

<u>LINE</u>	<u>FREQUENCY RANGE</u>	<u>COIL</u>	<u>COIL CONNECTIONS</u>	<u>PARALLEL CAPACITOR CONNECTIONS</u> Δ
1	27.7 KC-30.0 KC	L-1	(1-5) (3-6)	6-8-9-10-11
2	29.8 KC-33.1 KC	L-1	(1-5) (3-6)	6-8-10-11
3	31.8 KC-36.0 KC	L-1	(1-5) (3-6)	6-8-9-11
4	35.4 KC-39.0 KC	L-1	(1-5) (3-6)	6-8-11
5	38.0 KC-41.0 KC	L-1	(1-2) (3-6)	6-8-9-10-11
6	40.3 KC-45.0 KC	L-1	(1-2) (3-6)	6-8-10-11
7	43.0 KC-49.0 KC	L-1	(1-2) (3-6)	6-8-9-11
8	47.7 KC-56.0 KC	L-1	(1-2) (3-6)	6-8-11
9	49.5 KC-58.5 KC	L-1	(1-2) (3-6)	6-8-9-10
10	57.0 KC-72.3 KC	L-1	(1-2) (3-6)	6-8-10
11	67.0 KC-76.0 KC	L-2	(1-4) (6-7)	6-8-9-11
12	75.0 KC-88.0 KC	L-2	(1-4) (6-7)	6-8-11
13	77.5 KC-93.0 KC	L-2	(1-4) (6-7)	6-8-9-10
14	89.3 KC-114.5KC	L-2	(1-4) (6-7)	6-8-10
15	102.7KC-147.0KC	L-2	(1-4) (6-7)	6-8-9
16	136.6KC-210.0KC	L-2	(1-4) (6-7)	6-8

Δ CONNECTION FROM 6 TO 8 IS MADE BENEATH TERMINAL PLATE ON ALL SETS AT THE FACTORY.

Fig. 9. Connections - Output Filter (Dwg. 149A420)

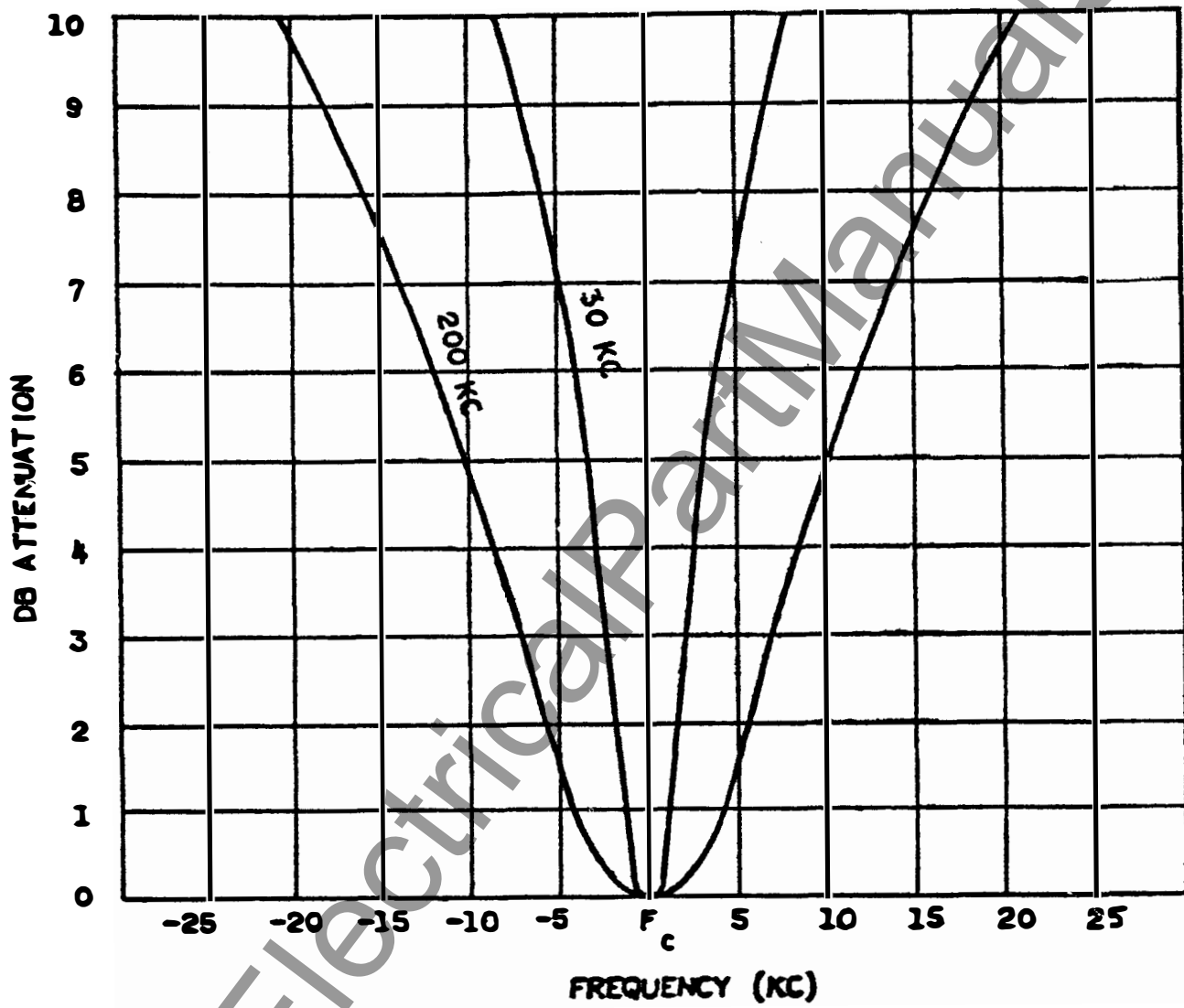

Fig. 10. Transmitter Output Filter Selectivity (Dwg. 377996)

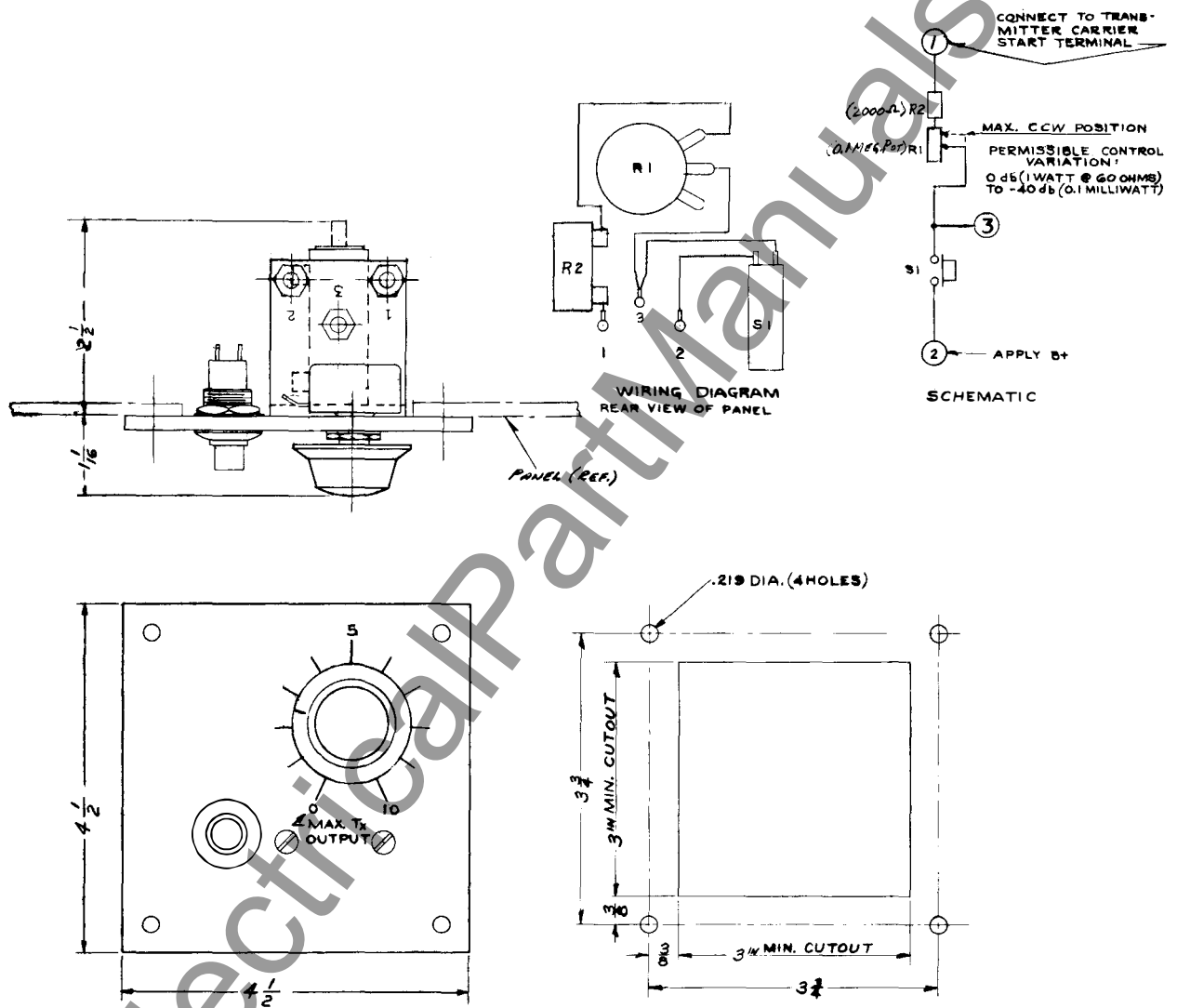

Fig. 11. Reserve Signal Detector Outline (Dwg. 329C703)

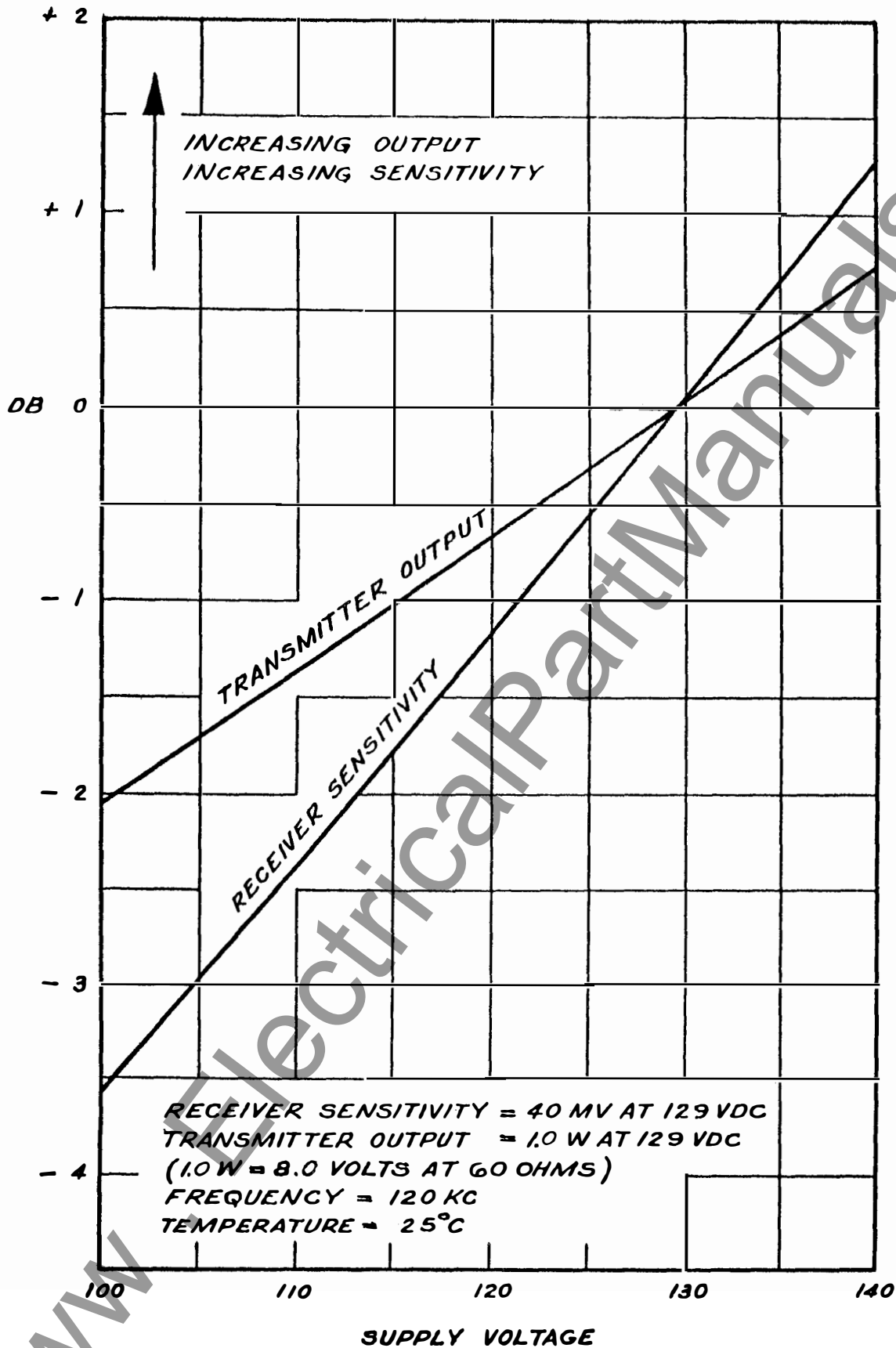

Fig. 12. Transmitter Output and Receiver Sensitivity Variations with Voltage (Dwg. 377999)

TRANSMITTER OUTPUT & RECEIVER SENSITIVITY
VARIATIONS WITH FREQUENCY

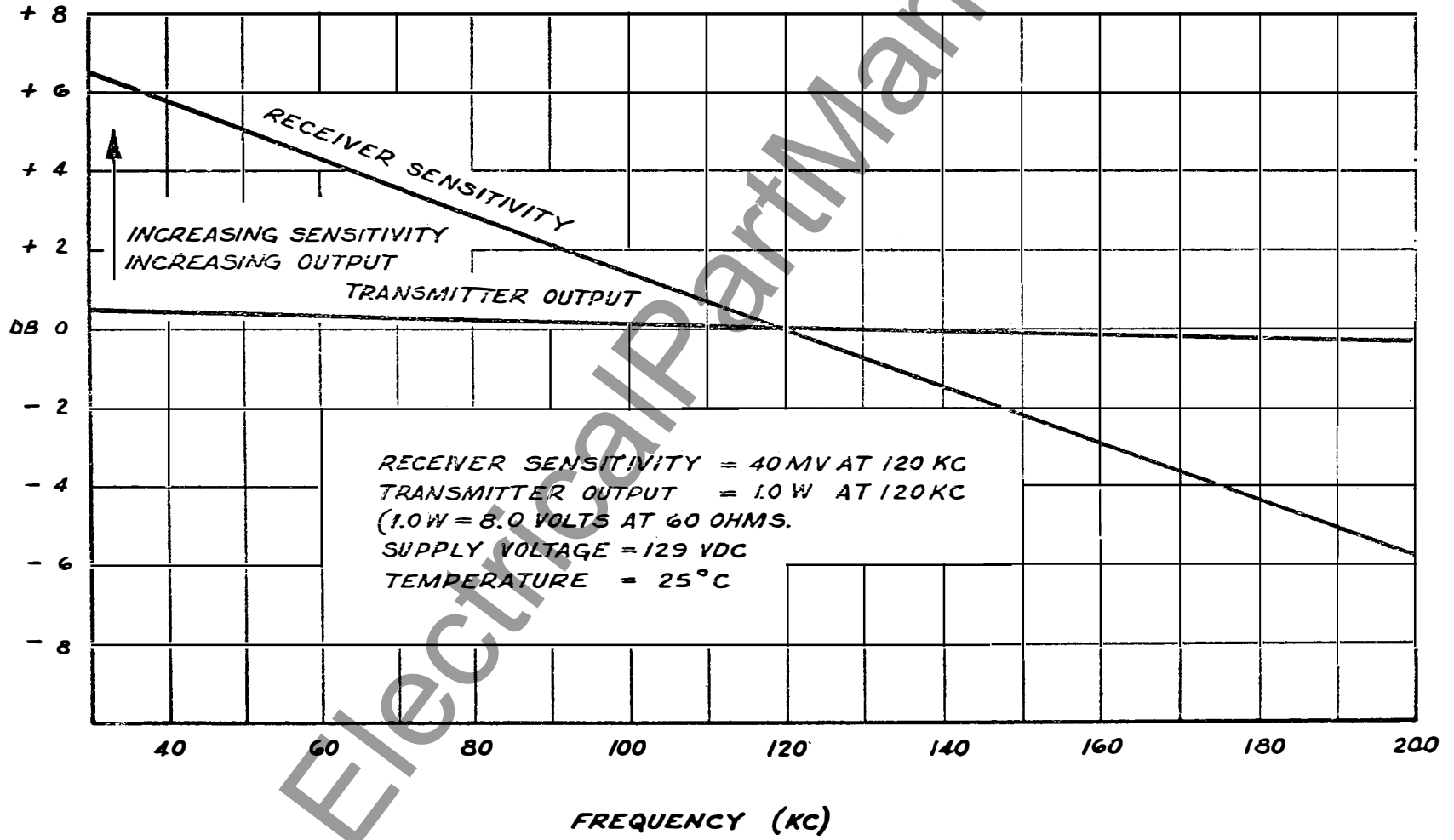

Fig. 13. Transmitter Output and Receiver Sensitivity Variations with Frequency (Dwg. 378000)

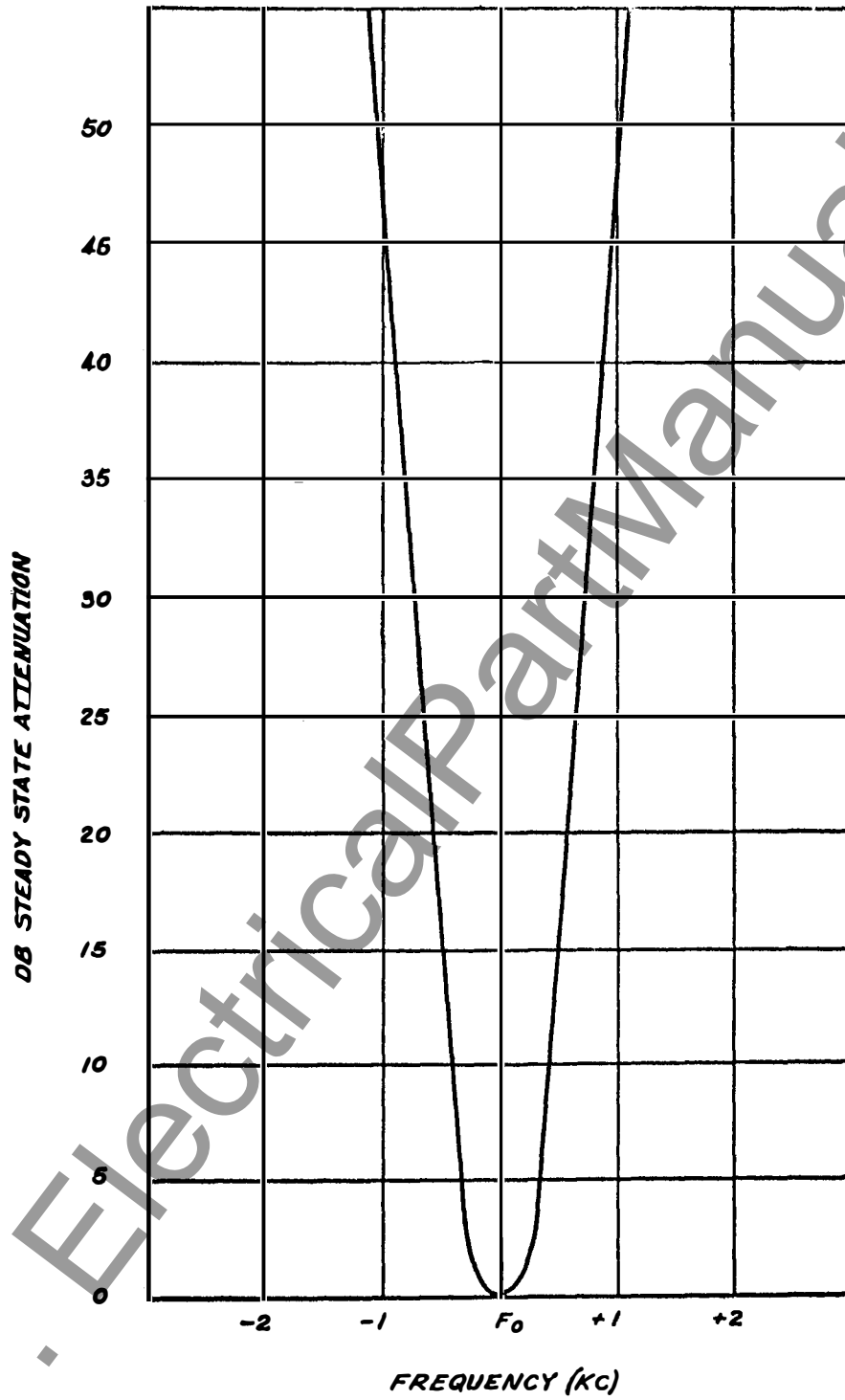
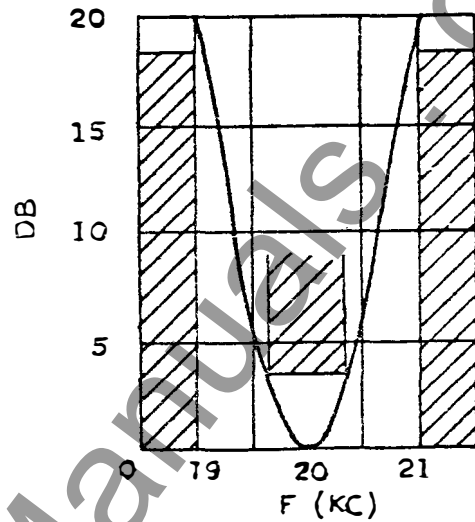
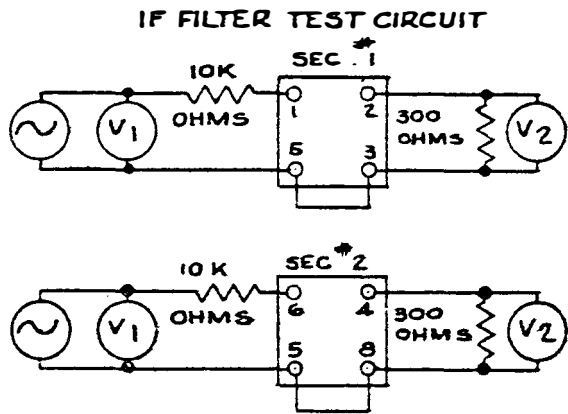
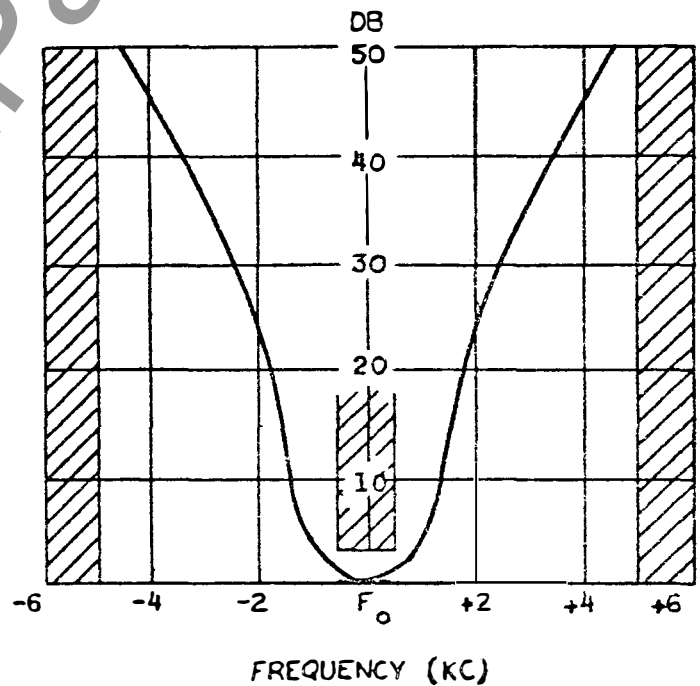
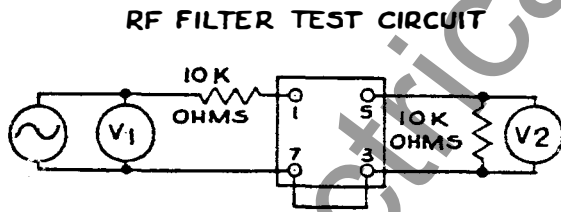

Fig. 14. Receiver Selectivity (Dwg. 377993)



Each section FL-2 requirement with typical selectivity curve
 Insertion loss 26 DB max.
 Including matching resistor.



FL-1 Requirement with typical selectivity curve at 120 KC. Insertion loss 18 DB max. Including matching resistor.

Fig. 15. Receiver Filter Limits (Dwg. 377995)

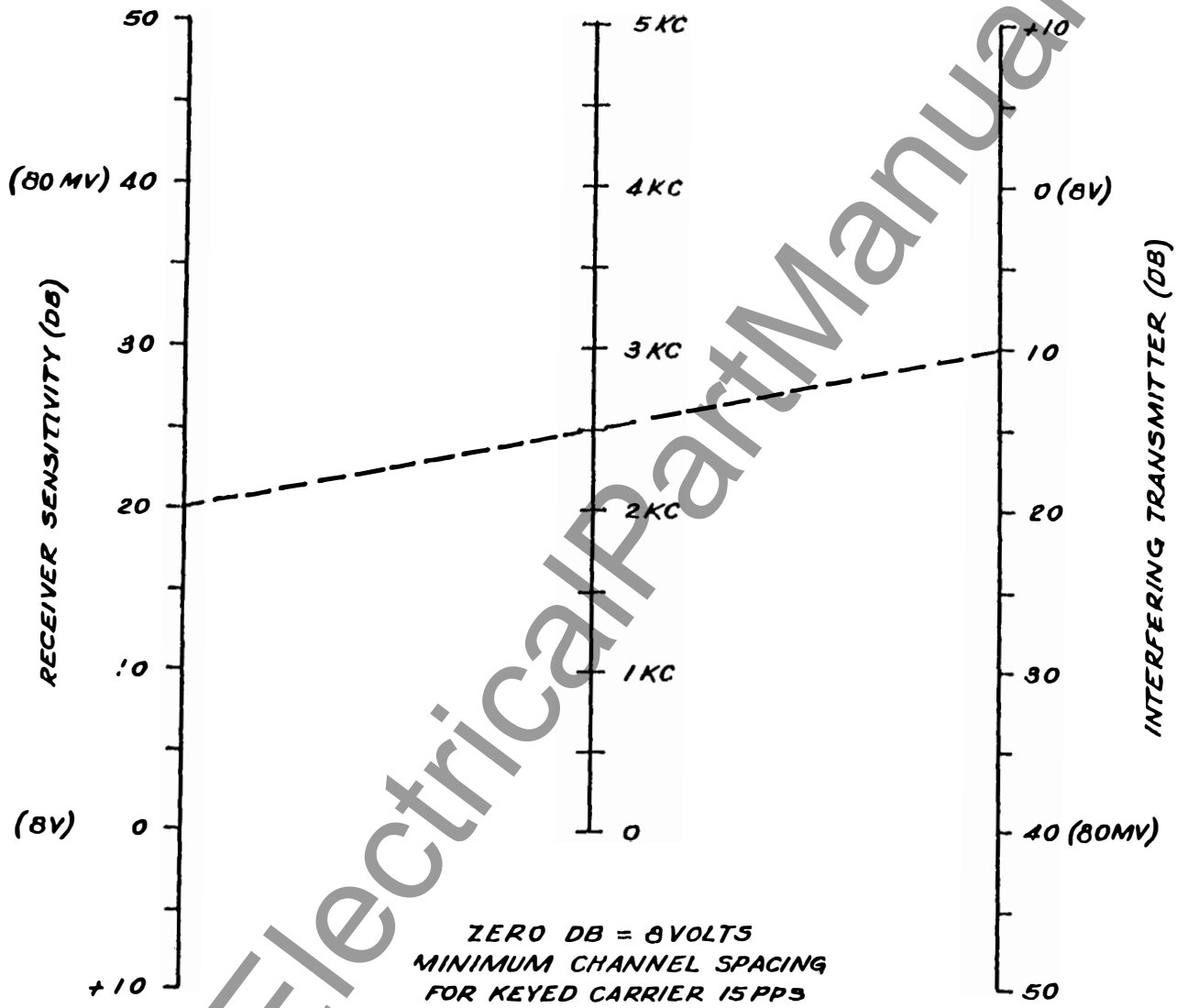
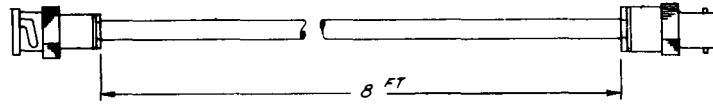
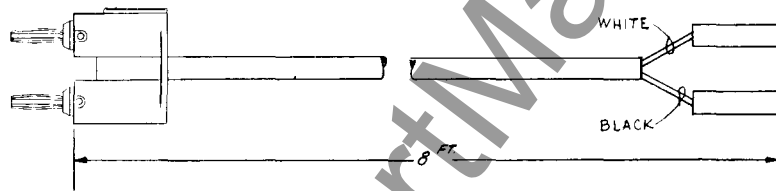

Fig. 16. Minimum Channel Spacing (Dwg. 377998)



Coaxial Lead... 756D346 G02



Output Lead... 756D346 G03

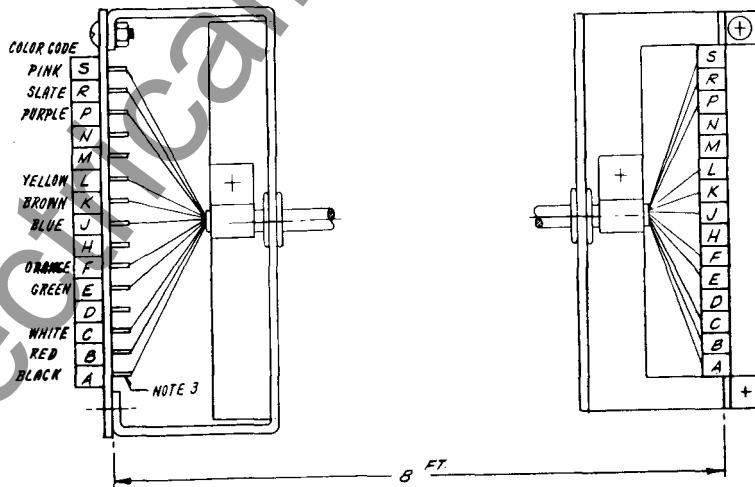

Main Harness... 756D346 G04

Fig. 17. Test Harness - (Complete Set)

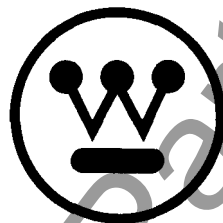

WESTINGHOUSE ELECTRIC CORPORATION
RELAY-INSTRUMENT DIVISION

NEWARK, N. J.

Printed in U.S.A.



INSTALLATION • OPERATION • MAINTENANCE I N S T R U C T I O N S

TYPE KR CARRIER RELAYING TRANSMITTER-RECEIVER

Flexitest Case Mounted —with provision for rear-mounter Voice Adapter Accessories.	Style
KR Reserve Signal Detector	470D167 GO2
250 Volt Resistor Unit	330C191 H01
Test Harness (Complete Set)	756D346 G01
Coaxial Lead	756D346 G02
Output Lead	756D346 G03
Main Harness	756D346 G04

TABLE OF CONTENTS

Introduction	Page 2
Specifications	Page 2
Description	
General	Page 3
Mechanical	Page 3
Electrical	
Transmitter	Page 4
Receiver	Page 4
Transmitter Control Circuits	Page 5
Reserve Signal Detector	Page 5
Communications	Page 5
Relaying Control Circuits	Page 5
Installation	
General	Page 6
Connections	
External	Page 6
Internal	Page 7

Adjustments

Transmitter	Page 7
Receiver	Page 7
Reserve Signal Detector	Page 8
250-Volt Resistor Unit	Page 8
Frequency Change	Page 8

Maintenance	Page 9
Application	Page 13
Electrical Parts List	Page 14

LIST OF TABLES

Table

1 D-C Pin Jack Measurements with Reference to B-	Page 10
2 Transistor DC Measurements with Reference to B-	Page 11
3 D-C Bleeder Measurements with Reference to B-	Page 12
4 Typical RF Signal Measurements for Receiver	Page 12
5 Typical RF Signal Measurements for Transmitter	Page 1'

*SUPERSEDES I.L. 41-941.1C
Denotes change from superseded issue.

LIST OF ILLUSTRATIONS

Figure	References
1 Outline – Flexitest Case	540D753
2 Internal Schematic	540D780
3 Relaying Control Circuits (HZ/HZM)	1-329C704
4 Relaying Control Circuits (K-Dar)	3-329C704
5 Relaying Control Circuits (GCX/GCY).....	2-329C704
6 Component Location.....	540D781
7 Supervisory Control Receiver Connection.....	223B498
8 Connections, 48-250 volts and Supervisory Control.....	407C971
9 Transmitter Output Filter Connections	149A420
10 Transmitter Output Filter Selectivity.....	C377996
11 Reserve Signal Detector – Outline and Schematic	329C703
12 Transmitter Output and Receiver Sensitivity Variations with D-C Voltage	C377999
13 Transmitter Output and Receiver Sensitivity Variations with Frequency.	C378000
14 Receiver Selectivity	C377993

15 Receiver Filter Limits	C377995
16 Minimum, Channel Spacing	C377998
17 Test Harness	756D346

CAUTION The voltages encountered in this equipment are dangerous to life. To be safe, disconnect the power source and close the grounding switch when servicing the equipment.

INTRODUCTION

The Type KR Relaying Transmitter-Receiver is designed for Distance Relaying, Telemetering, Supervisory Control and Sleet Detection. Facilities are provided for a plug-in type voice adapter. The basic design is for operation from 125-volt station batteries. However, the apparatus may also be operated from 48-volt or 250-volt station batteries by means of various internal connections. These various connections as well as most of the adjustments are made at the factory, although they can be changed in the field.

Although designed primarily for operation with Westinghouse protective relays, this apparatus may also be coordinated with other types of directional-distance relays and with most other contact keyed devices.

SPECIFICATIONS

Frequency Range.....	30-kc to 200-kc
Channel Attenuation Rating	40-db
Transmitter Power Output	1.0 watt at standard conditions (see Figs. 12 and 13). 0.5 watt with a 48-volt d-c supply.
Transmitter Harmonic Output	At least 46-db below fundamental.
Transmitter Output Impedance.....	Matches one 60-ohm coax. cable. (Suitable for 50-70 ohm cable.)
Transmitter Output Filter Selectivity	See Fig. 10
Transmitter and Receiver Oscillator and Frequency Stability	From -20°C to +50°C with simultaneous voltage variations from 100 to 140 VDC, the frequency remains with 0.01%.

Permissible Battery Voltage Ripple	7-½%
Ambient Temperature Range	-20°C to +50°C.
Non-Operating Temperature Range	-40°C to +70°C
Receiver Sensitivity	0.04 volts at standard conditions (see Figs. 10 and 18).
Receiver Selectivity	See Fig. 14
Receiver Signal-to-Noise Ratio Requirements	12 db
Minimum Channel Spacing	See Fig. 16
Power Input	115 ma at 48 VDC, 200-ma at 125 VDC, 1.28 amperes at 250 VDC.
Carrier On-Off Keying	Requires one pair of contacts capable of keying 8-ma DC at an open circuit voltage of 125 VDC.
Weight (With Flexitest Case)	Approximately 16-lbs.

CAUTION Refer application to Westinghouse when other transmitters are to be connected to the same coax cable as certain conditions may result in damage to the output transistors.

NOTE Standard conditions are taken as 129-volts, 120-kc and 25°C.

DESCRIPTION

General

This completely transistorized carrier-apparatus is a result of extensive field and laboratory tests. From these tests, it was proven that transistors provide superior reliability over tubes. In addition, the latest printed circuit and filter techniques have improved performance and greatly decreased the size. The expected long life of transistors as compared with vacuum tubes will reduce maintenance costs, and the low power requirements will produce important savings in battery and charger requirements.

Transistors perform the same functions as vacuum tubes. However, tubes operate by the flow of electrons in a vacuum between elements, while transistors depend upon the movement of electrons in a solid. This leads to a more rugged type of construction. Most transistors are made from either germanium

or silicon semi-conductor materials. The junction transistor consists of a thin slice of germanium or silicon with three different regions produced by introducing specific amounts of impurities. A thin wire is connected to each region. One outer region is called the emitter, the other the collector, and inserted between them is the base. These correspond roughly to the cathode, plate, and grid of a vacuum tube.

The transistors in this equipment are of the junction type, and both NPN and PNP configurations are used. In the NPN transistor, the majority of the current is carried by electrons. In the PNP transistor there is a deficiency of electrons. These deficiencies are known as "holes". For practical purposes holes may be considered as positively charged "electrons", and these provide most of the current flow in PNP units. In order to obtain maximum efficiency and reliability, both types are used in this equipment.

Silicon transistors are used in the transmitter and receiver output circuit in order to stabilize critical circuit performance at elevated temperatures.

Mechanical

This apparatus is supplied in a Flexitest case and may be either flush or projection mounted in

order to match other switchboard equipment. The outline dimensions and also the drilling plan for flush and projection mounting are shown by Fig. 1. The majority of the parts are mounted on a printed circuit board. This board may be readily removed as follows:

1. Remove the two output plugs from the red and black jacks.
2. Disconnect the receiver input coaxial cable connector.
3. Loosen the two screws at the top of the board.
4. Loosen the two screws at the bottom of the board and pull them out as far as they will extend.
5. Pull board down to disengage the terminals and lift out.

The transmitter output filter may be removed by removing four mounting screws from the bottom of the case and disconnecting the coaxial cable.

Fig. 6. shows the location of major components such as potentiometers, jack, test points, crystals, transistors, etc. External connections and the Schematic Diagram are shown by Fig. 2. The numbered terminals shown as squares apply to the external terminals.

Provisions are made for plugging the Voice Adapter Unit in the rear of the relaying equipment. Octal socket marked X-4 on the rear of the set accommodates the adapter plug. A buckle type strap on each side of the adapter holds the unit in place after it has been plugged in. The normal projection for a rear mounted Voice Adapter is 3-inches beyond that of the relaying equipment. When the KR Relaying Unit is supplied with the adapter, a patch cord is available on separate order. This patch cord plugs into the telephone jacks on the adapter and provides an extension to a conveniently located terminal board.

The panel cutout information necessary for mounting the Sleet Detector is shown by Fig. 11. This unit consists of a potentiometer and pushbutton switch mounted on a small panel, itself suitable for switchboard mounting.

For 250-volt operation, separate auxiliary resistors are required, as shown in Fig. 8.

Electrical

Transmitter

The transmitter is made of four main stages in-

cluding an oscillator, driver, power amplifier, and an output filter. In the oscillator, the crystal is operated as a resonant circuit between the collector of one transistor and the base of the other. The feedback is supplied through a capacitor from the collector of the second transistor to the base of the first transistor. The frequency is independent of voltage or temperature changes of the transistors. Thus the frequency stability is the stability of the crystal.

The input to the driver stage Q-10 is controlled by potentiometer, R-42 which also controls the transmitter power output. In HZM relaying CARRIER STOP provides about +40 volts for blocking. This is applied to Q-10 through T-6. Diode CR-5 prevents damage to the transistor when this positive voltage is applied to the collector. For CARRIER START (when in the blocked position) a small positive voltage is applied to the collector of Q-10 by means of bleeder resistors R-67 and R-68.

The power amplifier consists of two transistors Q-12 and Q-15, which are operated as class B amplifiers in push-pull. Resistors R-52 and R-55 are for stabilization.

The output transformer, T-7, matches coaxial cables of 50 to 70 ohms.

Resistor R-66 tends to keep the source impedance constant to permit proper tuning of the output filter.

The output filter consists of coils L-1 and L-2, capacitors C-19 through C-22. The filter is tunable, and is provided to attenuate harmonics and other spurious outputs. It should be noted that the filter contains no shunt elements, resulting in a reverse impedance free of "across the line" resonances.

Receiver

The receiver is a superheterodyne in order to obtain constant selectivity regardless of the channel frequency. (See Fig. 14.) The major stages include an input filter, attenuator, oscillator, mixer, IF filters, IF amplifiers, detector and a D-C power output stage.

The input filter prevents undesired signals from producing the IF frequency.

The receiver sensitivity is adjusted by means of the continuously variable input control R-1 and by

connecting or disconnecting resistors R-73 and R-74 in the IF stages.

The receiver oscillator (Q-2 and Q-3) is basically the same as the transmitter oscillator. The frequency is 20-kc above the incoming signal frequency.

The receiver channel frequency is determined by the input filter and the oscillator crystal. The frequency may be changed readily since both the filter and the crystal are plug-in components.

Mixing is accomplished by feeding the incoming signal to the emitter and the receiver oscillator signal to the base of the mixer Q-1. Mixer oscillator requirements are met through adjustment of potentiometer R-4. Injection into two separate elements, base and emitter, provides a circuit capable of handling greater signal level variations than one in which injection is made into only a single element such as the base.

This receiver uses an IF frequency of 20-kc. The overall selectivity is determined primarily by the IF filter FL-2. Typical characteristics of this filter are shown in Fig. 15.

The IF amplifier consists of transistors Q-4, Q-5 and Q-6.

The detector is a full wave bridge rectifier. This rectifier in conjunction with the IF amplifier Q-6, provides the necessary power to drive the D-C power output stage Q-7.

The final output stage Q-7 will supply approximately 18 milliamperes to a standard 1700 ohm distance relay RRH coil and its associated 500 ohm alarm coil. It may also be used to drive other relay coils such as is shown by Fig. 7, Supervisory Control Connections.

Transmitter Control Circuits

In the standby condition, although the oscillator is running, the transmitter driver has no emitter bias which results in no output.

Positive voltage applied to terminal 15 supplies this bias through a voltage dividing network, and transmitter output results. The actual configuration of the network is a function of supply voltage and application (Relaying, Telemetering, etc.) and is

discussed in the Adjustments section.

Output may be stopped in several ways. The method used with K-DAR relays is to remove the positive voltage applied to terminal 15. In the case of distance relaying with Westinghouse HZ/HZM relays, application of a positive voltage to terminal 18 will stop the transmitter output. Output may also be stopped by removal of negative battery from terminal 18.

Reserve Signal Detector

The Reserve Signal Detector is shown by Fig. 11. Effectively R-1 is a remote transmitter output control. This control is obtained through varying the driver stage (Q-10) emitter bias, and is effective over a 40-db range of transmitter output. The detector is switched into service by S-1. By adjusting R-1 for a given receiver relay current at the far end of the channel, a relative measure of the channel attenuation may be obtained. This is discussed further in the section on Adjustments.

Communications

The transmitter output is reduced approximately 6-db when the Type KR voice adapter attachment is used. Relaying takes preference, and full output is obtained since full voltage is supplied to terminal 15.

Relaying Control Circuits

Figs. 3, 4 and 5 show simplified diagrams of the relaying control circuits.

1. K-DAR and GCY Relaying (Figs. 4 and 5)

The control of the carrier set is obtained through the CARRIER START and CARRIER STOP contacts. These contacts are shown in their normal standby condition.

The K-DAR or GCY relays operating from the voltage and current on the transmission line, detect and determine the direction of a line fault and thereby control the carrier transmitter and receiver.

The control of the carrier set is such as to start the transmission of carrier when fault power on the transmission line is flowing out of the line section being protected. Conversely, when fault power is flowing into this line section, the control is such as to block the transmitter and keep it from being turned on by secondary functions such as sleet detection

TYPE KR CARRIER SET

and communication, should these functions be in use at the same time. Should carrier be received from the remote station, the hold coil and alarm coil will energize through transistor Q-7 in the receiver.

When carrier start operation occurs, the CARRIER START contact opens applying a positive voltage (see Figs. 4 and 5) to terminal 15 of the carrier set. This puts a potential on the driver stage in the transmitter and also applies proper bias for the power amplifier.

When a carrier stop operation occurs, the CARRIER STOP contact closes, which removes B+ (terminal 15) from the driver and the power amplifier stages in the transmitter. CARRIER STOP, terminal 18, on the carrier set is permanently connected to terminal 14, for K-DAR and GCY relaying.

2. HZM Relaying (Fig. 3)

The control of the carrier set is effected by the CARRIER START and the CARRIER STOP contacts. These contacts are shown in their normal standby condition.

The HZ-HZM relays operating from the voltage and current on the transmission line, detect and determine the direction of a line fault and thereby control the carrier transmitter and receiver.

The control of the carrier set is such as to start the transmission of carrier when fault power on the transmission line is flowing out of the line section being protected. Conversely, when fault power is flowing into this line section, the control is such as to block the transmitter and keep it from being turned on by secondary functions such as sleet detection and communication, should these functions be in use at the same time. Should carrier now be received from the remote station, the hold coil and alarm coil will energize through transistor Q-7 in the receiver.

When carrier start operation occurs, the CARRIER START contact closes applying the full battery supply voltage to terminal 15 of the carrier set. This puts a potential on the driver stage in the transmitter and also applies proper bias for the power amplifier.

When a carrier stop operation occurs, the CARRIER STOP contact opens. This applies a positive voltage (see Fig. 3) to terminal 18 which blocks the driver stage and the power amplifier stage

It is possible under certain conditions that the signals from two transmitters, attempting to block a third receiver, would be of such amplitude, phase and frequency as to cause the RRH coil current to "pulsate". It would then be possible to have a false trip.

In the case of the KR set for relaying 3-terminal lines, the transmitter frequencies (to avoid this possibility of false trip) should be separated by 100 cycles. All receivers and one transmitter would be for the desired center frequency. One of the other transmitters would be 100 cycles above, the other 100 cycles below this center frequency.

INSTALLATION

General

Upon receipt of a unit, whether shipped separately or in an assembly, an immediate inspection should be made. Carefully check for damage or shortages.

For necessary clearances and mounting dimensions, see the following illustrations:

Flexitest Case Mounting..... Fig. 1

Sleet Detector..... Fig. 11

Connections

External

The external connections will vary slightly depending on the application, but in general will be along the lines described as follows: (Refer to the Schematic Diagram, Fig. 2.)

Terminals	11.....	Ground
	12.....	Coaxial Cable
	13 and 19.....	Supervisory Preference Contacts
	14.....	B- "CARRIER STOP" return
	15.....	Battery positive through carrier start contacts
	16.....	Battery positive for alarm cutoff (used with communication)
	17.....	B-
	18.....	Carrier Stop for HZM Relaying
	19.....	B+
	20.....	Relay Coil

CAUTION If the transmitter output load is removed while the transmitter is energized, the transistors in

the power amplifier will be permanently damaged. A dummy load should be connected to the transmitter output if the coax is disconnected and the transmitter is to be energized.

When tuning line coupling equipment, short the coaxial cable to ground before changing taps on the Line Tuner or matching transformer.

Internal

Necessary internal connections are generally made at the factory, to customer order, before apparatus shipment. For reference purposes, these are outlined in the following tabulation. Check the proper bleeder resistors before applying voltage to the equipment.

OPERATION	BLEEDER RESISTORS IN THE CIRCUIT
48-Volt K-DAR, HZM, and GCY Relaying, Telemetering, and Supervisory	R-47 and R-48
125-Volt K-DAR and GCY Relaying	R-45, R-47 and R-48
125-Volt HZM Relaying, Telemetering, and Supervisory	R-41, R-45, R-47 and R-48
250-Volt K-DAR and GCY Relaying	R-45, R-47 and R-48
250-Volt HZM Relaying, Telemetering, and Supervisory	R-39, R-40, R-41, R-45, R-47 and R-48

Various combinations of the inductors and capacitors of the transmitter output filter are required depending on the channel frequency. These are tabulated in Fig. 9.

Adjustments

This apparatus is generally tuned to and tested at the specified channel frequency before shipment. Final adjustments must be made in the field and are described in the following paragraphs. Fig. 6 shows the locations of the various controls.

Transmitter

1. Disconnect the coaxial cable and replace with a 50, 60, or 70 ohm non-inductive resistor depending on the characteristic impedance of the cable used.

2. Fig. 9 shows typical output filter connections for various frequency ranges. In some cases it may be necessary to use either a higher or lower range to tune the filter to resonance.

3. Insert fuses F-1 and F-2 to apply power to the apparatus.

4. Connect an A-C Vacuum Tube Voltmeter (VTVM) across the non-inductive load.

5. Unblock the transmitter by closing the CARRIER TEST SWITCH. An alternative is to jumper battery positive to terminal 15.

6. Beginning with the output control R-42 at the maximum counterclockwise position, advance it clockwise until a reading appears on the VTVM. Tune capacitor C-19 for a maximum voltmeter reading.

7. While increasing R-42, tune the output filter for maximum output until the output across the resistor is approximately 8 volts. (See Figs. 12 and 13.) (Approximately 5.5-volts when operating from 51-volt station battery.)

8. Open the test switch and reconnect the coaxial cable.

Receiver

1. The oscillator output control R-4 is pre-set at the factory. However, should any of the oscillator components be changed (including the transistors and the crystal) R-4 will require adjustment.

a. Connect an A-C VTVM to jacks J-3 and J-4.

b. Adjust R-4 for a 0.3 volt reading on the meter.

2. The unit is shipped to have a gain of approxi-

mately 250 millivolts (to produce 10 ma relay current) with input control R-1 in maximum clockwise position. About 10-db additional gain or 80 millivolt sensitivity can be obtained by clipping out resistor R-74, which is connected to the base of Q-4 and the B+ supply for the IF. Approximately 10-db gain or 25 millivolt sensitivity can be obtained by clipping out resistor R-73, which is connected to the base of Q-5 and the B+ supply for the IF. Resistor R-71 has been selected at the factory to provide an overall gain of approximately 25 millivolts.

a. Sensitivity Adjustment for Noise

If the maximum on-frequency noise level is known or can be measured, the receiver can be adjusted for this level. Disconnect the coaxial cable and connect a 60-ohm non-inductive resistor and a VTVM across terminals 11 and 12. Energize the transmitter and output control R-42 for the same output as the maximum noise. Then adjust the receiver input control R-1 to obtain 1-ma output current. If it is impossible to obtain 1-ma output current with control R-1 in the maximum clockwise position, then clip out resistor R-74, which is connected to the base of Q-4. If the gain is still insufficient, clip out resistor R-73, which is connected to the base of Q-5. After completing the adjustment of R-1, restore the transmitter to full output.

b. Sensitivity Adjustment for Remote Signal

When the maximum on-frequency noise is unknown and cannot be conveniently measured, the receiver may be adjusted for the remote signal. First determine the channel attenuation using a Sierra voltmeter or some other convenient method. Disconnect the coaxial cable and connect a 60-ohm non-inductive resistor and a VTVM across terminals 11 and 12. Add 15-db to the channel attenuation. This compensates for average variations such as channel and voltage variations. For example, if the channel attenuation is 5-db, add this to the 15-db making a total of 20-db. Taking this from 8 volts output of the transmitter, the receiver should then be set for a sensitivity of 0.8 volts. To do this, adjust the transmitter output control R-42 for 0.8 volts and then adjust the receiver input control so as to obtain 10-ma output current. If it is impossible to obtain 10-ma output current with control R-1 in the maximum clockwise position, clip out resistor R-74, which is connected to the base of Q-4. If the gain is still insufficient, clip out resistor R-73, which is connected to the base of Q-5. After completing the

adjustment of R-1, restore the transmitter to full output.

It must be kept in mind that the two preceding adjustment procedures are to be used as a guide and will cover the majority of cases; however, cases may arise where conditions change. For example, if the adjustment is made per part a., the noise may increase due to various reasons such as bad insulators, which would require adjusting the receiver to be less sensitive. In the adjustment of part b., the attenuation may increase due to sleet or line switching, which would necessitate increasing the sensitivity of the receiver.

Reserve Signal Detector

Due to different types of operation and supply voltages, it is not practical to have a calibrated dial for this unit. However, calibration may be made at installation by recording transmitter output (either in db or volts) at various knob settings of the detector unit. Then, by adjusting the knob so as to obtain 10 milliamperes relay current at a remote receiver, any increase or decrease in line attenuation may be noted as the difference between the original setting, and the setting required to obtain the given 10 milliamperes.

250-Volt Resistor Unit

With the apparatus energized, adjust R-4 in the 250-volt resistor unit so as to obtain 125-volts at terminals 17 (B-) and 19 (B+) on the relaying set.

Frequency Change

If the frequency is changed in the field, it is necessary to change the input filter FL-1 to the desired channel frequency. This filter is of the plug-in type and may be removed by unsnapping the clamp and pulling the filter out. The transmitter oscillator crystal Y-2 must be changed to the desired channel frequency. The receiver oscillator crystal Y-1 must be changed to the desired channel frequency plus 20 kc. Figure 9 shows the connections for the transmitter output filter. It is necessary to unsolder the existing connections and make the new connections per the chart. After completing the preceding, the tuning procedure as described under Adjustments for transmitter and receiver should then be followed.

Note also that capacitors C2 and C9 in the transmitter and receiver crystal oscillator circuits, respectively, may have to be changed. For fre-

quencies below 110 kc, these capacitors are 270 mmf. each. For frequencies of 110 kc and above, the capacitors are 140 mmf. each.

CAUTION Turn power OFF before removing filters or transistors, as high transient currents may cause permanent damage to the transistors.

MAINTENANCE

Voltage values should be recorded after adjustment in order to establish reference values which will be useful when checking the apparatus. The readings will remain fairly constant over an indefinite period unless a failure occurs. However, if transistors are changed, there may be considerable difference in these readings without the overall performance being affected.

Typical voltage and current values are given as follows. Voltages should be measured with VTVM. Readings may vary as much as $\pm 20\%$.

In the following paragraphs, the transmitter may be unblocked (transmitting) by closing the CARRIER START circuit in the case of HZM relaying, and by opening the CARRIER START circuit in the case of K-DAR and GCY relaying.

1. For D-C pin jack measurements with reference to B-, refer to Table 1.

2. For transistor D-C measurements with reference to B-, refer to Table 2.

3. For D-C bleeder measurements with reference to B-, refer to Table 3.

4. For typical RF signal measurements for receiver, refer to Table 4.

5. For typical RF signal measurements for transmitter, refer to Table 5.

6. Removal of Printed Circuit Board from Flexitest Case.

To remove the printed circuit board, unplug J-15 and J-16 located near the output filter. Loosen the two screws inside the case near the top. Loosen the slotted thumb screws at the lower end of the board and pull these screws out as far as they will extend. Also remove the receiver coaxial cable plug.

Pull board down so as to disengage the terminals, and lift out.

7. Removal of the Output Filter

After the printed board has been removed, remove the screws on the outside of the case at the bottom. Lift out filter and disconnect the coaxial cable.

8. Receiver Filters

Fig. 15 shows typical receiver selectivity curves both RF and IF. If the filters are checked in a test setup, it is necessary to use an accurate signal generator or preferably a signal generator and a frequency counter.

9. Minimum Test Equipment for Installation

a. Milliammeter 0-25 ma DC.

b. 60-ohm 5-watt non-inductive resistor.

c. A-C Vacuum Tube Voltmeter (VTVM). Voltage range 0.003 to 30 volts, frequency range 60 cycles/sec to 230-kc, input impedance 7.5 megohms.

d. D-C Vacuum Tube Voltmeter (VTVM)

Voltage Range: 0.15 to 300 volts

Input Impedance: 7.5 megohms

10. Desirable Test Equipment for Apparatus Maintenance

a. All items listed in Sections 8 and 9.

b. Signal Generator

Output Voltage: up to 8 volts

Frequency Range: 20-kc to 230-kc

c. Oscilloscope

d. Ohmmeter

e. Capacitor checker

f. Test harness (See Fig. 17)

TABLE I

D-C PIN JACK MEASUREMENTS WITH REFERENCE TO B-

Description	Jack	CONDITION A Tx-Blocked †† Rx-No Signal		CONDITION B Tx-Blocked Rx-With Signal		CONDITION C Tx-Unblocked Rx-No Signal	
		129 VDC	51 VDC	129 VDC	51 VDC	129 VDC	51 VDC
RF Input	J-2	0	0	0.3 V	0.3 V		
DC Q-1 Base	J-3	20 V	20 V	20 V	20 V		
DC R _x B+	J-4	20 V	20 V	20 V	20 V		
DC R _x Osc	J-5	7 V	7 V	7 V	7 V		
DC Q-5 Base	J-6	20 V	20 V	20 V	20 V		
B-	J-7						
DC-P1-E	J-8	110 V	32 V	110 V	32 V	110 V	32 V
DC-Q-7 Base	J-9	69 V	0 V	78 V	2.3 V	66 V	0.3 V
DC Q-7 Emit	J-10	70 V	1.0 V	78 V	1.4 V	66 V	1.0 V
DC T _x Osc	J-11	7 V	7 V	7 V	7 V	7 V	7 V
B+	J-12	129 V	51 V	129 V	51 V	129 V	51 V
DC Q-10 Base	J-13					18 V	18 V
DC Q-10 Emit	J-14					18 V	18 V
RF ma out	J-15					130 ma	130 ma
DC ma RRH and ALARM				18 ma	* 18 ma		

†† Tx = transmitter, Rx = receiver

TABLE 2

TYPICAL TRANSISTOR DC MEASUREMENTS WITH REFERENCE TO B-

Transistor	Condition A Tx-Blocked Rx-No Signal (Volts)			Condition B Tx-Blocked Rx-With Signal (Volts)			Condition C Tx-Unblocked Rx-No Signal (Volts)		
	E†	B†	C†	E†	B†	C†	E†	B†	C†
Q-1	20.0	20.0	0.38	20.0	20.0	0.4			
Q-2	7	7.2	1.8	7	7.2	1.8			
Q-3	6.2	8.0	2	6.2	8	2.0			
Q-4	20.0	20.0	2.6	20.0	20.0	2.8			
Q-5	20.0	20.0	2.6	20.0	20.0	2.8			
Q-6									
129 VDC	110	110	129	115	114	129			
51 VDC	32	32	51	32	32	51			
Q-7									
129 VDC	70	68	129	78	80	86			
51 VDC	1.0	0	51	1.4	2.2	7.0			
Q-8	6.2	8	2	6.2	8	2	6.2	8	2
Q-9	7	7.2	1.8	7	7.2	1.8	7	7.2	1.8
Q-10††							18	18	0.4
Q-12††							0.27	0.20	50
Q-15††							0.27	0.20	50

† E-Emitter; B-Base; C-Collector.

†† With respect to term F on printed board.

TABLE 3

D-C BLEEDER MEASUREMENTS WITH REFERENCE TO B-

Measurement	129 VDC			51 VDC		
	A†	B†	C†	A†	B†	C†
Junction R-61 and R-62 (J-8)	110V	110V	110V	32V	32V	32V
Junction R-61 and R-27 (J-10)	70V	78V	66V	1.0V	1.4V	1.0V
Junction R-27 and R-60 (P1-P)	69V	77V	65V	0	0	0
Junction CR-8 and R-64 (P1-K)	58V	58V	58V	51V	51V	51V
Junction R-48 and R-47 (J-14)	—	—	18V	—	—	18V
Junction R-45 and R-47 (TP-9)	—	—	45V	—	—	51V
Junction R-45 and R-41 (TP-8)	—	—	98V	—	—	51V

†Conditions: A — Tx-Blocked, Rx-No Signal; B — Tx-Blocked, Rx-With Signal; C — Tx-Unblocked, Rx-No Signal.

TABLE 4
TYPICAL RF SIGNAL MEASUREMENTS FOR RECEIVER
(Made with 0.1 Volt at Terminal 5 of FL1)

Check Point	25 MV Sensitivity (Volts)	80 MV Sensitivity (Volts)	250 MV Sensitivity (Volts)
With Receiver Crystal Out			
FL1-5 to Gnd.	0.1	0.1	0.1
T1-1 to Gnd.	0.1	0.1	0.1
Q1-E to Gnd.	0.05	0.05	0.05
Q1-C to Gnd.	0.07	0.07	0.07
T3-1 to Gnd.	0.07	0.07	0.07
Q4-C to Gnd.	0.07	0.07	0.07
With Receiver Crystal In			
Q4-C to Gnd.	0.5	0.5	0.25
J6 to Gnd.	0.15	0.1	0.08
Q5-C to Gnd.	7.0	1.7	0.8
Q6-B to Gnd.	2.0	0.5	0.4
Q6-C to Gnd.	13.0	10.0	8.0
T4-1 to Gnd.	13.0	10.0	8.0
T4-3 to T4-4	4.5	3.5	2.5
J9 to J10 (DC)	0.74	0.75	0.65

TABLE 5

TYPICAL RF SIGNAL MEASUREMENTS FOR TRANSMITTER	
CHECK POINT	VOLTS
T5-1 to Gnd.	5.5
T5-3 to Gnd.	1.0
J13 to Gnd.	0.085
Q10-C to Gnd.	6.0
T6-2 to Gnd.	6.0
Q12-B to Gnd.	0.8
Q15-B to Gnd.	0.8
Q12-C to Gnd.	38.0
Q15-C to Gnd.	38.0
T7-5 to Gnd.	9.8
Output to Gnd.	8.0

APPLICATION

1. Receiver Selectivity (Fig. 14)

This shows a typical curve of the overall selectivity of the receiver under steady state conditions.

2. Transmitter Output Selectivity (Fig. 10)

Typical curves are shown so that approximate bandwidths for keying purposes can be determined for any carrier frequency between 30-kc and 200-kc.

3. Minimum Channel Spacing (Fig. 16)

This is a graph from which minimum channel spacing can be obtained provided the signal strength of the interfering transmitter and the sensitivity setting of the receiver are known. These can be obtained from calculations or by measurements.

For example, if the interfering transmitter voltage is measured (at the receiver) and found to be 2.5

volts, this would be 10-db down from 8 volts. This point can be located on the right hand column of the graph. Then, if the receiver sensitivity were set to operate on 0.8 volts or 20-db, this point would be located on the left hand column. A line could then be drawn through the two points as shown by the dotted line. The intersection of this line with the center line indicates the minimum channel spacing. In this case if the interfering signal is being keyed on-off, at 15 pps, the minimum spacing would be 2.5-kc.

4. Transmitter Output and Receiver Sensitivity Variations with Voltage (Fig. 12)

These curves show the variation of transmitter output and receiver sensitivity with changes in supply voltage, at 120-kc and 25°C. The increase and decrease in transmitter output above or below 1.0 watts may be obtained in db from the transmitter curve. 1.0 watts is about 8.0 volts with a 60-ohm load.

The increase and decrease in receiver sensitivity above or below 40 millivolts can similarly be

TYPE KR CARRIER SET

obtained in db from the receiver curve. 40 millivolts sensitivity represents the input signal required for proper operation.

5. Transmitter Output and Receiver Sensitivity Variations with Frequency (Fig. 13)

These curves show the variation of transmitter output and receiver sensitivity with variation in frequency, at a supply voltage of 129 VDC, and 25°C. They may be used in the same manner as Fig. 12.

6. Supervisory Control Connections (Fig. 7)

When supervisory control is used with relaying, the supervisory control relay coil is connected in

series with the RRH coil in place of the alarm relay. When supervisory control is used alone, a 1200-ohm resistor R3 is connected in series with the control relay coil by removing the jumper across R3, as shown in Fig. 7. In order to maintain proper mark space ratio, the relay bias current is adjusted for 9 milliamperes as indicated.

The receiver RF filter and the IF filter limits are shown on Fig. 15. Both filters are of the plug-in type and the test circuits with pin connections are shown at the top of each curve. The IF filter is divided into two separate sections. The selectivity shown is for each section, and the pin connections for each section are also shown in the test circuit sketch.

ELECTRICAL PARTS LIST

CIRCUIT SYMBOL	FUNCTION	DESCRIPTION	MFR. CODE	MANUFACTURER'S DESIGNATION
<u>CAPACITORS</u>				
C-1	Rcvr. Bleeder	2.0 μ f, \pm 20%, 200 VDC, Paper	1	330C567 H11
†C-2	Rcvr. Osc. Feedback	140/270 μ f, \pm 20%, 500 VDC, Mica	1	330C566 H43 or 330C566 H57
C-3	Rcvr. Osc. Bleeder Bypass	0.02 μ f, MRC, 600 VDC, Disc	1	330C569 H47
C-5	Q-6 Emitter Bypass	1.0 μ f, \pm 20%, 200 VDC Paper	1	330C567 H09
C-6	Rcvr. Rectifier Bypass	Same as C-5		
C-7	B- to B+ Bypass	2 μ f, \pm 10%, 600 VDC, Paper	1	14C9400 H18
C-8	B- to GND	1.0 μ f, \pm 10%, 1000 VDC, Paper	1	14C9400 H17
†C-9	Xmtr. Osc. Feedback	Same as C-2		
C-10	Xmtr. Osc.	Same as C-3		
C-11	Key Filter	0.1 μ f, \pm 20%, 200 VDC, Paper	1	330C567 H02
C-12	Q-10 Emitter Bypass	0.25 μ f, \pm 20%, 200 VDC, Paper	1	330C567 H05
C-13	Q-10 Bleeder Bypass	Same as C-12		
C-14	PA Base Bypass	Same as C-12		

†Note: 140 μ f for osc. freq. 110-kc and above.
270 μ f for osc. freq. below 110-kc.

ELECTRICAL PARTS LIST

CIRCUIT SYMBOL	FUNCTION	DESCRIPTION	MFR. CODE	MANUFACTURER'S DESIGNATION
<u>CAPACITORS (Concluded)</u>				
C-18	PA Bleeder	0.5 μ f, \pm 20%, Paper	1	330C567 H06
C-19	Output Filter Tuning	500 μ f, Variable, Air	1	328C092 H01
C-20	Output Filter	390 μ f, \pm 5%, 2500 VDC, Mica	1	330C561 H15
C-21	Output Filter	680 μ f, \pm 5%, 2500 VDC, Mica	1	330C561 H21
C-22	Output Filter	1200 μ f, \pm 5%, 2500 VDC, Mica	1	330C561 H27
C-24	FL-2 Decoupling	Same as C-12		
C-25	Q-7 Emitter	12 mfd, \pm 20%, 200 VDC	1	187A177 H01
<u>CRYSTAL DIODES</u>				
CR-1	Bridge Rectifier	General Purpose, IN63	1	584C433 H02
CR-2	Bridge Rectifier	Same as CR-1		
CR-3	Bridge Rectifier	Same as CR-1		
CR-4	Bridge Rectifier	Same as CR-1		
CR-5	Q-10 Collector	Same as CR-1		
CR-6	*Q-7 Base-Emitter	*Type IN4574		
CR-7	Voltage Regulator	Type 1N768,	1	584C434 H02
CR-8	Voltage Regulator	Type 1N1369	1	584C434 H05
CR-9	Q-7 Collector	*Type IN3811	1	*185A089H08

ELECTRICAL PARTS LIST

CIRCUIT SYMBOL	FUNCTION	DESCRIPTION	MFR. CODE	MANUFACTURER'S DESIGNATION
<u>FUSE HOLDERS</u>				
FH-1	B-	For Type 3AGC Fuses	1	584C271 H02
FH-2	B+	Same as FH-1		
<u>FUSES</u>				
F-1	B-	3AGC 3/4 amp.	1	S#330C691 H12
F-2	B+	Same as F-1		
<u>FILTERS</u>				
FL-1	Rcvr. RF Bandpass	* 30 to 200 kc Freq. to be specified by customer	1 1 1	
FL-2	Rcvr. IF Bandpass	20-kc Fixed Freq.	1	
<u>CONNECTORS</u>				
J-1	Printed Circuit	Printed Circuit Female Plug	1	54-B-7125 H03
J-2	RF Input	UG-185-U	1	584C292 H07
J-3	Rcvr. Osc. Output	Terminal Studs	1	330C592 H01
J-4	Rcvr. Mixer-Amp Supply	Same as J-3		
J-5	Rcvr. Osc. Supply	Same as J-3		
J-6	Q-5 Base	Same as J-3		
J-7	B-	Same as J-3		
J-8	Q-6 Supply	Same as J-3		

ELECTRICAL PARTS LIST

CIRCUIT SYMBOL	FUNCTION	DESCRIPTION	MFR. CODE	MANUFACTURER'S DESIGNATION
<u>CONNECTORS (Concluded)</u>				
J-9	Q-7 Base	Same as J-3		
J-10	Q-7 Emitter	Same as J-3		
J-11	Xmtr. Osc. Supply	Same as J-3		
J-12	B+	Same as J-3		
J-13	Xmtr. Osc. Output	Same as J-3		
J-14	Q-10 Supply	Same as J-3		
J-15	Output Filter	Banana Tip Red	1	328C093 H01
J-16	Output Filter GND	Banana Tip Black	1	328C093 H02
P-1	Printed Circuit	Printed Circuit Male Plug	1	54-B-7126 H03
<u>INDUCTORS</u>				
L-1	Core and Coil Assembly	11 MH Total – 6 MH Tap (Part of FL-3)	1	329C450
L-2	Core and Coil Assembly	2.5 MH (Part of FL-3)	1	329C449
L-3	RF Choke	1.0 MH, 300 ma	2	R-300
L-4	RF Choke	Same as L-3		
<u>TRANSISTORS</u>				
Q-1	Rcvr. Mixer	*Type 2N525	1	*184A638H13
Q-2	Rcvr. Osc.	Type 2N414	1	* 184A638H14

ELECTRICAL PARTS LIST

CIRCUIT SYMBOL	FUNCTION	DESCRIPTION	MFR. CODE	MANUFACTURER'S DESIGNATION
		<u>TRANSISTORS (Concluded)</u>		
Q-3	Rcvr. Osc.	Same as Q-2		
Q-4	Rcvr. IF	Same as Q-1		
Q-5	Rcvr. IF	Same as Q-1		
Q-6	Rcvr. IF	* Type 2N657	1	* 184A638H15
Q-7	Rcvr. Output	* Type 2N698	1	* 762A585H02
Q-8	Xmtr. Osc.	Same as Q-2		
Q-9	Xmtr. Osc.	Same as Q-2		
Q-10	Xmtr. Amp.	Same as Q-1		
Q-12	Xmtr. PA	Type 2N498	1	330C587 H12
Q-15	Xmtr. PA	Same as Q-12		
		<u>RESISTORS</u>		
R-1	Rec. Input	25 K, $\pm 20\%$, 1/4 W, Pot.	1	584C276 H23
R-2	Filter Matching	10 K, $\pm 10\%$, 1/2 W	1	330C595 H37
R-3	Filter Load	Same as R-2		
R-4	Rcvr. Osc.	1 K, $\pm 20\%$, 1/4 W, Pot.	1	584C276 H19
R-5	Rcvr. Voltage Divider	6.2 K, $\pm 5\%$, 1 W	1	330C666 H68
R-6	Q-2 Collector	1.2 K, $\pm 5\%$, 1/2 W	1	330C664 H51
R-8	Rcvr. Voltage Divider	30 K, $\pm 5\%$, 2 W	1	330C668 H84
R-9	Rcvr. Voltage Divider	Same as R-8		

ELECTRICAL PARTS LIST

CIRCUIT SYMBOL	FUNCTION	DESCRIPTION	MFR. CODE	MANUFACTURER'S DESIGNATION
		<u>RESISTORS (Continued)</u>		
R-10	Q-2 Base	Same as R-2		
R-11	Q-2 Base	100 K, $\pm 5\%$, 1/2 W	1	330C665 H05
R-12	Q-3 Collector	Same as R-6		
R-13	Q-3 Emitter	390 Ohms, $\pm 5\%$, 1/2 W	1	330C664 H39
R-14	Q-3 Base	Same as R-2		
R-15	Q-3 Base	Same as R-11		
R-16	Rcvr. Osc. Bleeder	2.2 K, $\pm 10\%$, 1/2 W	1	330C595 H41
R-17	Rcvr. Osc. Bleeder	18 K, $\pm 10\%$, 2 W	1	330C597 H40
R-18	Rcvr. Osc.	9.1 K, $\pm 5\%$, 1/2 W	1	330C664 H72
R-19	Q-4 Bias	100 Ohms, $\pm 5\%$, 1/2 W	1	330C664 H25
R-20	Q-4 Bias	Same as R-2		
R-21	Q-5 Bias	150 Ohms, $\pm 5\%$, 1/2W	1	330C664 H29
R-22	Q-5 Bias	Same as R-2		
R-23	Q-6 Bias	330 Ohms, $\pm 5\%$, 1/2 W	1	330C664 H37
R-24	Q-6 Bias	Same as R-2		
R-25	Q-6 Emitter	Same as R-19		
R-26	Q-7 Base	Same as R-6		
R-27	Q-7 Bias	20 Ohms, $\pm 5\%$, 1/2 W	1	330C664 H08
R-28	Xmtr. Osc. Bleeder	Same as R-18		
R-29	Xmtr. Osc. Bleeder	Same as R-17		
R-30	Xmtr. Osc. Bleeder	Same as R-16		

ELECTRICAL PARTS LIST

CIRCUIT SYMBOL	FUNCTION	DESCRIPTION	MFR. CODE	MANUFACTURER'S DESIGNATION
		<u>RESISTORS (Continued)</u>		
R-31	Q-8 Base	Same as R-11		
R-32	Q-8 Base	Same as R-2		
R-33	Q-8 Emitter	Same as R-13		
R-34	Q-8 Collector	Same as R-6		
R-35	Q-9 Base	Same as R-11		
R-36	Q-9 Base	Same as R-2		
R-37	Q-9 Collector	Same as R-6		
R-38	Key Filter	Same as R-23		
R-39	Buffer Voltage Divider	36 K, $\pm 5\%$, 2 W	1	330C668 H86
R-40	Buffer Voltage Divider	Same as R-39		
R-41	Buffer Voltage Divider	Same as R-2		
R-42	Xmtr. Osc. Output	Same as R-4		
R-43	Q-10 Bias	Same as R-23		
R-44	Q-10 Bias	33 K, $\pm 5\%$, 1/2 W	1	330C664 H85
R-45	Buffer Voltage Divider	15 K, $\pm 10\%$, 1 W	1	330C596 H39
R-47	Buffer Voltage Divider	6.8 K, $\pm 5\%$, 1/2 W	1	330C664 H69
R-48	Buffer Voltage Divider	15 K, $\pm 5\%$, 1/2 W		330C664 H77
R-49	PA Bias	27 K, $\pm 5\%$, 2 W	1	330C668 H83

ELECTRICAL PARTS LIST

CIRCUIT SYMBOL	FUNCTION	DESCRIPTION	MFR. CODE	MANUFACTURER'S DESIGNATION
		<u>RESISTORS (Concluded)</u>		
R-50	Xmtr. PA	Same as R-19		
R-52	Q-12 Emitter	10 Ohms, $\pm 5\%$, 1/2 W	1	330C664 H01
R-55	Q-15 Emitter	Same as R-52		
R-59	Xmtr. Bleeder	47 Ohms, $\pm 10\%$, 1/2 W	1	330C595 H09
R-60	Recvr. Bleeder	1 K, $\pm 5\%$, 25 W	1	584C416 H57
R-61	Recvr. Bleeder	600 Ohms, $\pm 5\%$, 25 W	1	584C416 H47
R-62	Recvr. Bleeder	350 Ohms, $\pm 5\%$, 25 W	1	584C416 H52
R-64	Xmtr. Bleeder	1200 Ohms, $\pm 5\%$, 25 W	1	584C416 H64
R-66	T-7 Load	560 Ohms, $\pm 5\%$, 2 W	1	330C668 H43
R-67	Xmtr. Blocking	10 Ohms, $\pm 5\%$, 2 W	1	330C668 H01
R-68	Xmtr. Blocking	10 K, $\pm 10\%$, 10 W	1	330C577 H01
R-69	Q-10 Emitter	Same as R-19		
R-70	FL2 Decoupling	470 Ohms, $\pm 10\%$, 1/2 W	1	330C595 H21
R-71	Q-4 Emitter	150 Ohms, $\pm 10\%$, 1/2 W	1	330C595 H15
R-72	Q-5 Emitter	68 Ohms, $\pm 10\%$, 1/2 W	1	330C595 H11
R-73	Q-5 Base	180 Ohms, $\pm 10\%$, 1/2 W	1	330C595 H16
R-74	Q-4 Base	2.7 K, $\pm 5\%$, 1/2 W	1	330C664 H59
R-75	Q-4 Collector	22 K, $\pm 10\%$, 1/2 W	1	330C595 H41
R-76	Q-5 Collector	Same as R-75		

ELECTRICAL PARTS LIST

CIRCUIT SYMBOL	FUNCTION	DESCRIPTION	MFR. CODE	MANUFACTURER'S DESIGNATION
<u>TRANSFORMERS</u>				
T-1	Rcvr. Input	Impedance Ratio 10 K; 10K	1	S#1962798, L-633005
T-2	Rcvr. Osc.	Impedance Ratio 10 K: 400 ohms	1	S#1962797, L-633003
T-3	Rcvr. Mixer	Impedance Ratio 25 K: 300 ohms	1	S#1962697, L-592171
T-4	IF Output	Impedance Ratio 4 K: 500 ohms	1	S#1962693, L-592289
T-5	Xmtr. Osc.	Same as T-2		
T-6	Xmtr. Buffer	Impedance Ratio 10 K: 400 ohms CT	1	S#1962698, L-592170
T-7	Xmtr. Output	Impedance Ratio 1930: 60	1	S#1962694, L-633000
<u>TEST POINTS</u>				
TP-1	R-5	Terminal studs	1	330C592 H02
TP-2	R-8	Same as TP-1		
TP-3	R-17	Same as TP-1		
TP-4	R-18	Same as TP-1		
TP-5	R-28	Same as TP-1		
TP-6	R-39 & R-40	Same as TP-1		
TP-7	R-41	Same as TP-1		
TP-8	R-45	Same as TP-1		
TP-9	R-47	Same as TP-1		

ELECTRICAL PARTS LIST

CIRCUIT SYMBOL	FUNCTION	DESCRIPTION	MFR. CODE	MANUFACTURER'S DESIGNATION
<u>SOCKETS</u>				
X-1	FL-1	Octal	1	330C689 H01
X-2	FL-2	Same as X-1		
X-4	Rear Mounted Voice Adaptor	Same as X-1		
XY-1	Rec. Y-1	Crystal	1	584C606 H01
XY-2	Xmtr. Y-2	Same as XY-1		
<u>CRYSTALS</u>				
Y-1	Rcvr. Osc.	Specify Channel Freq. Plus 20-kc	1	328C083
Y-2	Xmtr. Osc.	Specify Freq. Same as Channel Frequency	1	328C083
<u>RESERVE SIGNAL DETECTOR</u> (S#470D167G02)				
R-1	Resistor, Level Control	100 K, 2 W, Pot.	1	51-D-1976 H17 (S#1475074)
R-2	Resistor, Limiting	2000 ohms, 2" tube.	1	1267296
S-1	Test Switch	SPST Normally Open	1	327C854 H01

LIST OF MANUFACTURERS

1. Westinghouse Electric Corporation
2. National Co., Inc., Malden, Mass.

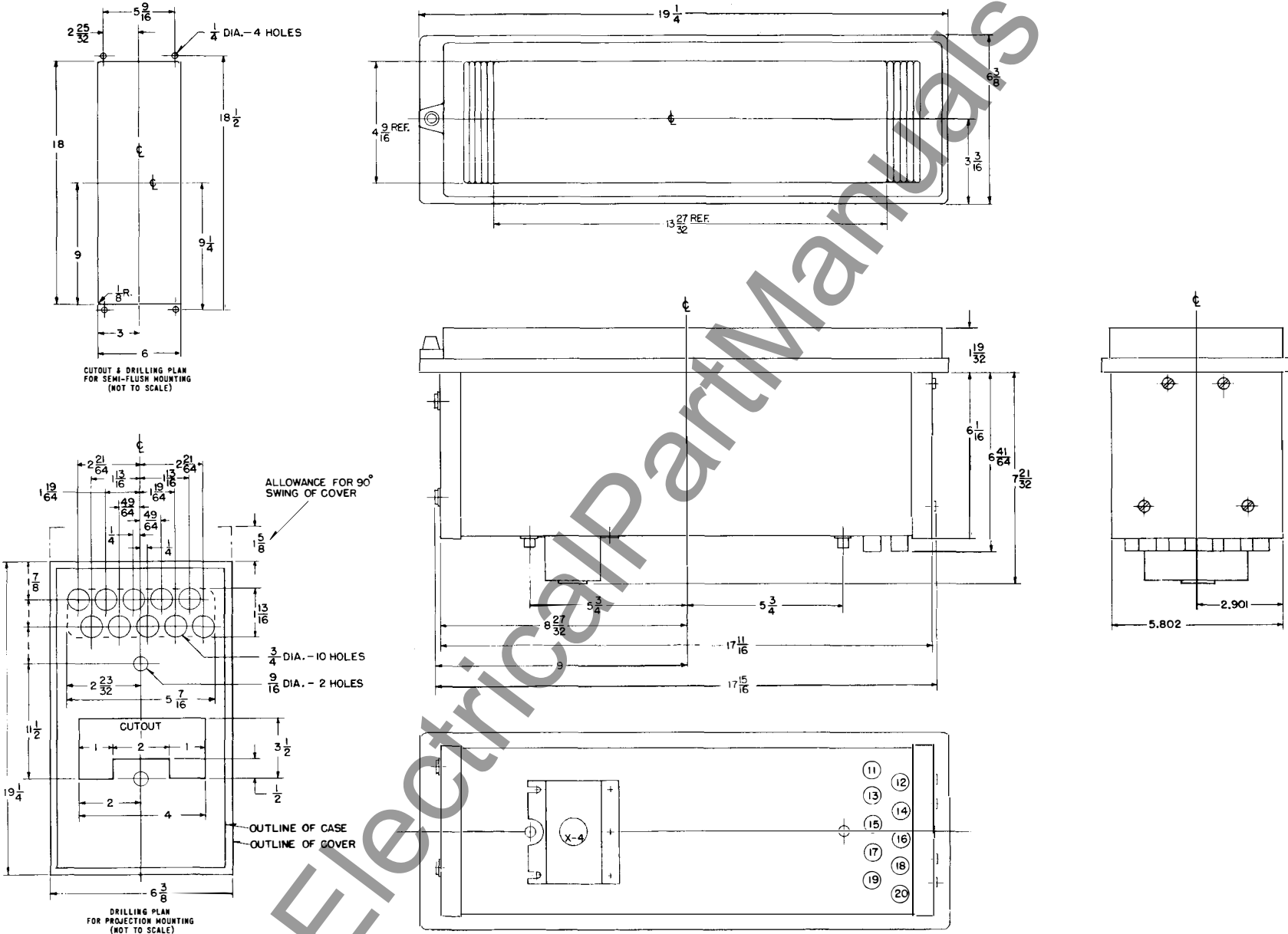
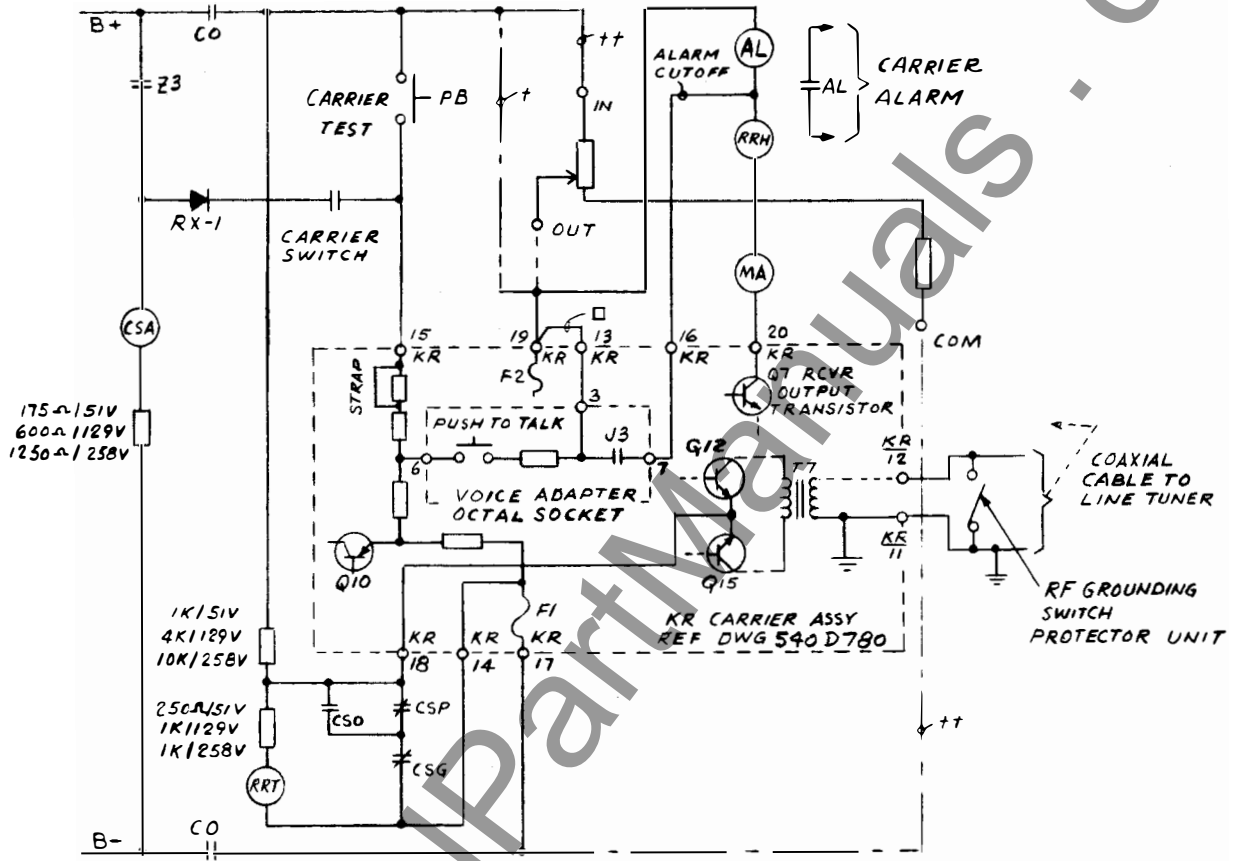

Fig. 1 Outline Drawing, (Flexitrest Case) (540D753)

TYPE KR CARRIER SET



REQUIREMENTS FOR HZ/HM RELAYING

SUPPLY VOLTAGE	CARRIER START	CARRIER STOP	STRAP
5VDC	+5V, 7MA	+28V	IN
129VDC	+129V, 8MA	+40V	IN
258VDC	+258V, 8MA	+40V	OUT

- NOTES
- + FOR 5V & 129VDC SUPPLY.
 - ++ FOR 258VDC SUPPLY USE 330C191H01 RESISTOR UNIT REF DWG 223B497
 - FOR SUPERVISORY CONTROL PREFERENCE CONTACTS.

- KR RELAYING TRANSMITTER / RELY EXTERNAL CONNECTIONS
- TERMINAL CONNECTION
- 11. GROUND
 - 12. COAXIAL CABLE
 - 13. SUPERVISORY PREFERENCE CONTACT
 - 14. CARRIER STOP B- RETURN
 - 15. CARRIER START (POSITIVE)
 - 16. ALARM CUTOFF FOR COMMUNICATIONS
 - 17. B MINUS
 - 18. CARRIER STOP (HZ/HZM)
 - 19. B PLUS
 - 20. RELAY COIL

* Fig. 3- Relaying Control Circuits - HZ/HZM (Dwg. 1-329C704)

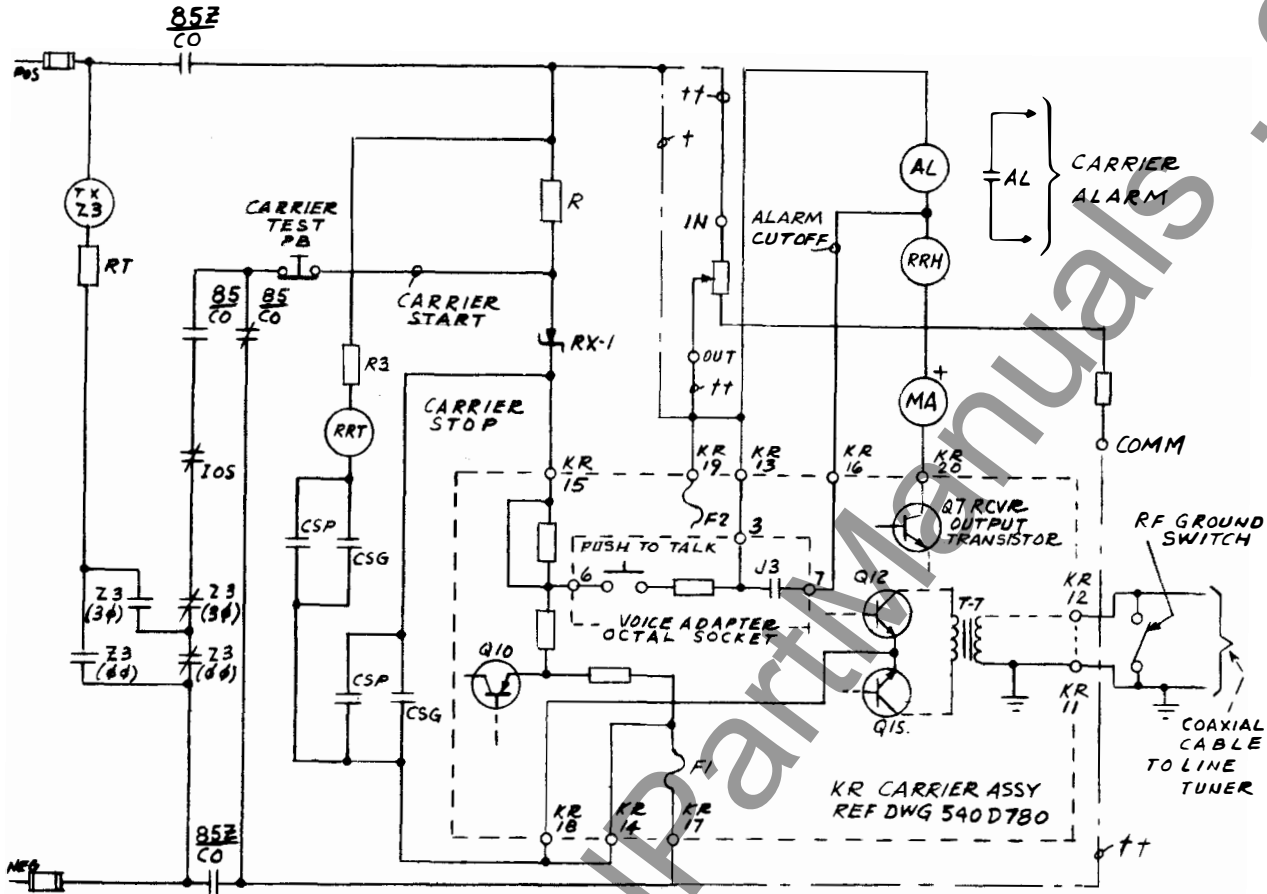

REQUIREMENTS FOR K-DAR RELAYING

SUPPLY VOLTAGE	CARRIER START	CARRIER STOP	R
51 VDC	+ 37V, 7MA	0 VOLTS	2K
129 VDC	+100V 8MA	0 VOLTS	3.75K
258 VDC	+100V 8MA	0 VOLTS	19K

NOTES

KR RELAYING TRANSMITTER /
REC.V. EXTERNAL CONNECTIONS

TERMINAL CONNECTION

- 11 GROUND
- 12 COAXIAL CABLE
- 13 SUPERVISORY PREFERENCE CONTACT
- 14 CARRIER STOP B- RETURN
- 15 CARRIER START (POSITIVE)
- 16 ALARM CUTOFF FOR COMMUNICATIONS
- 17 B MINUS
- 18 CARRIER STOP (HZ/HZM)
- 19 B PLUS
- 20 RELAY COIL

- + FOR 51 & 129 VDC SUPPLY
- ++ FOR 258VDC SUPPLY USE
330C191H01 RESISTOR UNIT
REF DWG 223B497

* Fig. 4-Relaying Control Circuits-K-Dar (Dwg. 3-329C704)

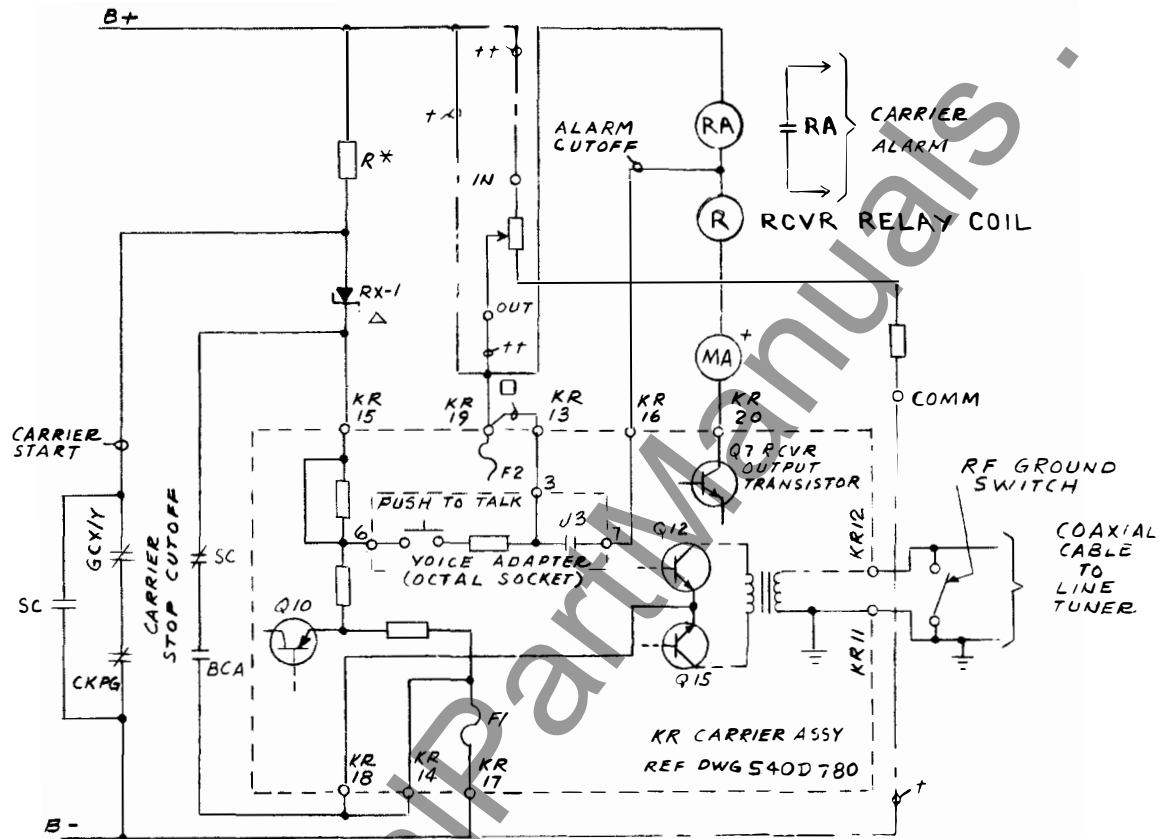

REQUIREMENTS FOR GCX/GCY RELAYING

SUPPLY VOLTAGE	CARRIER START	CARRIER STOP	R
51 VDC	+ 37V, 7MA	0 VOLTS	2K
129 VDC	+ 100V, 8MA	0 VOLTS	3.75K
258 VDC	+ 100V, 8MA	0 VOLTS	19.K

KR RELAYING TRANSMITTER /
RCV. EXTERNAL CONNECTIONS
TERMINAL CONNECTION

11. GROUND
12. COAXIAL CABLE
13. SUPERVISORY PREFERENCE CONTACT
14. CARRIER STOP B- RETURN
15. CARRIER START (POSITIVE)
16. ALARM CUTOFF FOR COMMUNICATIONS
17. B MINUS
18. CARRIER STOP (HZ/HZM)
19. B PLUS
20. RELAY COIL

NOTES

- * FOR "R" USE OHMITE VITREOUS ENAMELED DIVIDOHM ADJUSTABLE 4K OR 20K 25W RESISTOR, CONNECT & ADJUST FOR VALUES SHOWN
- Δ TYPE IN3051
- + FOR 51 & 129 VDC SUPPLY
- ++ FOR 258VDC SUPPLY USE 330C191H01 RESISTOR UNIT REF DWG 223B497
- FOR SUPERVISORY CONTROL PREFERENCE CONTACTS

Fig. 5. Relaying Control Circuits -GCX/GCY (Dwg. 2-329C704)

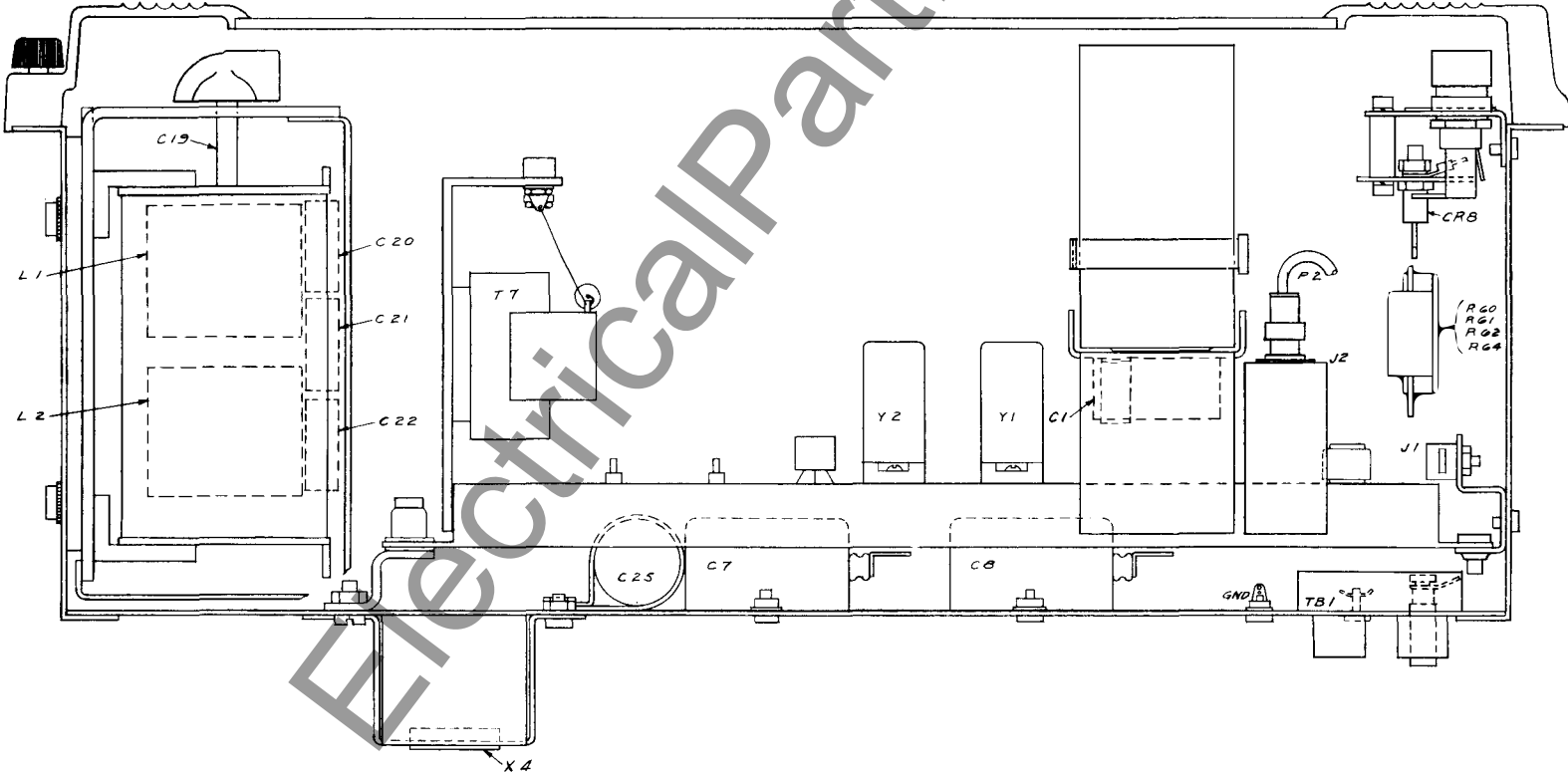
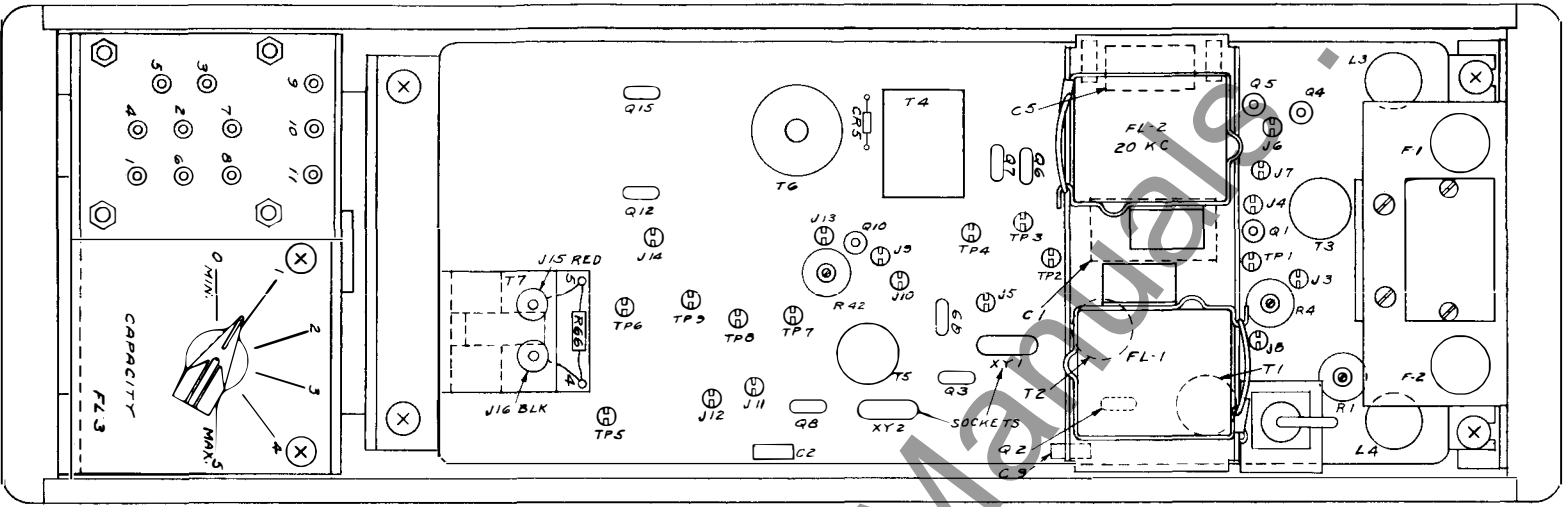
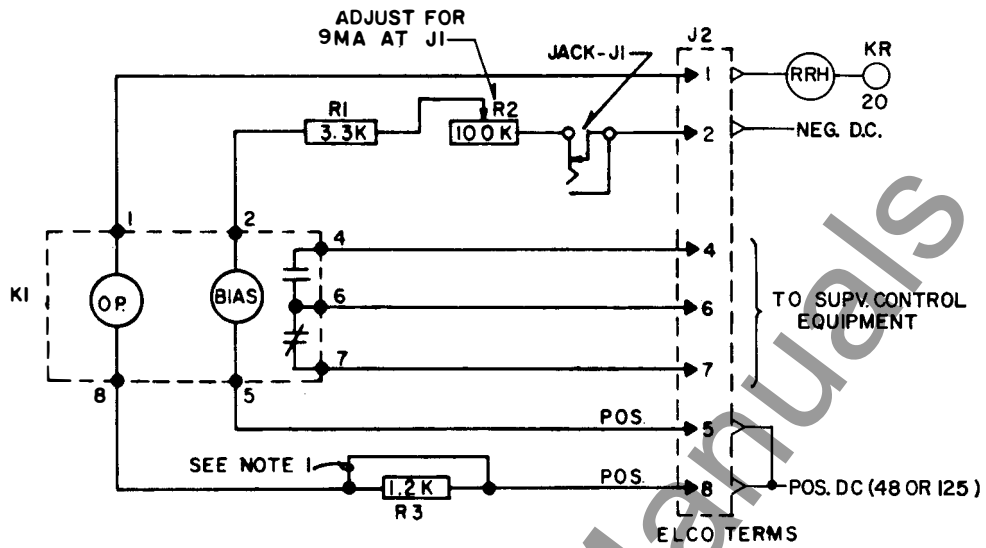
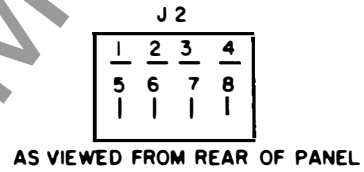

Fig. 6. Component Location (Dwg. 540D781)



- NOTES:
1. REMOVE FOR KR CARRIER PLUS SUPV. CONTROL WITHOUT RELAYING.
 2. POLARITY SHOWN CLOSES CONTACT BETWEEN TERMINALS 4 & 6.



629A552

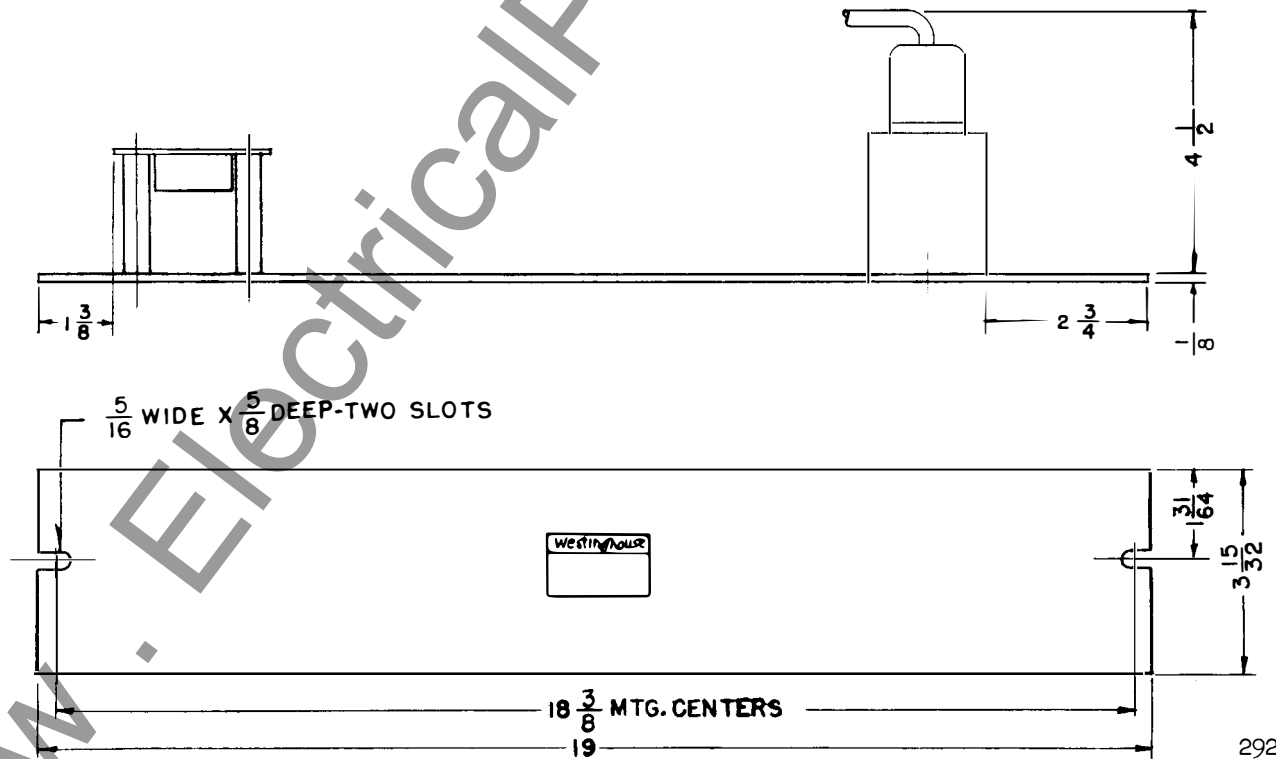

292B991

Fig. 7. Supervisory Control Auxiliary Relay Connections (Dwg. 629A552) and Outline (Dwg. 292B991).

**CONNECTIONS FOR 48-250 VOLT SERVICE AND
SUPERVISORY CONTROL APPLICATION
(CHANGES FROM JUMPERS SHOWN ON INTERNAL SCHEMATIC, FIG.2)**

250-VOLT OPERATION

FOR A 250 VOLT SUPPLY, RESISTOR UNIT 330C191H01 IS USED AS SHOWN ON APPLICATION DRAWING 329C704

FOR HZ/HZM OPERATION, THE JUMPER HAS BEEN REMOVED FROM TP-6 TO TP-7. (NOT REMOVED FOR K-DAR RELAYING).

RESISTOR UNIT SCHEMATIC:

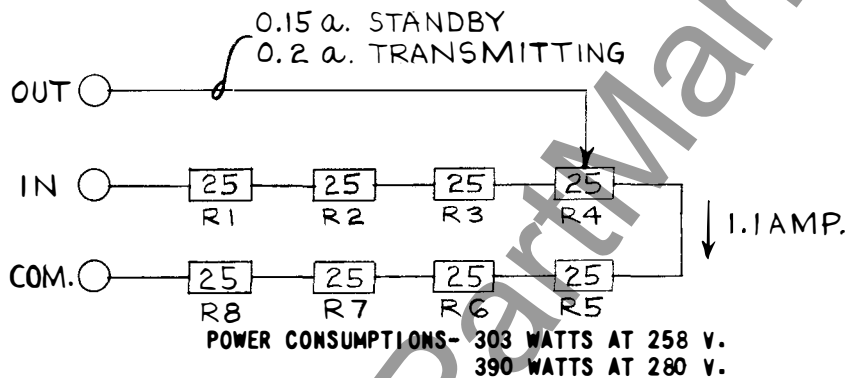

NOTE: KR SUPPLY VOLTAGE WILL BE APPROXIMATELY 144 VOLTS UNDER STANDBY CONDITION WHEN BATTERY VOLTAGE IS 280 VOLTS.

125-VOLT HZ/HZM OPERATION

JUMPER TP-7 AND TP-8 IS REMOVED.

48 VOLT OPERATION

ON PRINTED CIRCUIT BOARD ADDITIONAL JUMPERS ARE CONNECTED AS FOLLOWS:

- BETWEEN TP8 AND TP9
- BETWEEN TP5 AND J12
- BETWEEN TP1 AND TP2
- BETWEEN TP3 AND TP4

IN THE FT CASE, JUMPERS ARE CONNECTED ACROSS R60 AND R64, AND THE CONNECTION BETWEEN R64 AND DIODE CR8 IS REMOVED.

IN ADDITION, FOR 48-VOLT SUPERVISORY CONTROL, R59 IS CONNECTED INTO THE CIRCUIT.

Fig. 8. Connections, 48-250 Volts and Supervisory Control (Dwg. 407C971)

TRANSMITTER OUTPUT FILTER FL-3 CONNECTIONS

<u>LINE</u>	<u>FREQUENCY RANGE</u>	<u>COIL</u>	<u>COIL CONNECTIONS</u>	<u>PARALLEL CAPACITOR CONNECTIONS</u> Δ
1	27.7 KC-30.0 KC	L-1	(1-5) (3-6)	6-8-9-10-11
2	29.8 KC-33.1 KC	L-1	(1-5) (3-6)	6-8-10-11
3	31.8 KC-36.0 KC	L-1	(1-5) (3-6)	6-8-9-11
4	35.4 KC-39.0 KC	L-1	(1-5) (3-6)	6-8-11
5	38.0 KC-41.0 KC	L-1	(1-2) (3-6)	6-8-9-10-11
6	40.3 KC-45.0 KC	L-1	(1-2) (3-6)	6-8-10-11
7	43.0 KC-49.0 KC	L-1	(1-2) (3-6)	6-8-9-11
8	47.7 KC-56.0 KC	L-1	(1-2) (3-6)	6-8-11
9	49.5 KC-58.5 KC	L-1	(1-2) (3-6)	6-8-9-10
10	57.0 KC-72.3 KC	L-1	(1-2) (3-6)	6-8-10
11	67.0 KC-76.0 KC	L-2	(1-4) (6-7)	6-8-9-11
12	75.0 KC-88.0 KC	L-2	(1-4) (6-7)	6-8-11
13	77.5 KC-93.0 KC	L-2	(1-4) (6-7)	6-8-9-10
14	89.3 KC-114.5 KC	L-2	(1-4) (6-7)	6-8-10
15	102.7 KC-147.0 KC	L-2	(1-4) (6-7)	6-8-9
16	136.6 KC-210.0 KC	L-2	(1-4) (6-7)	6-8

Δ CONNECTION FROM 6 TO 8 IS MADE BENEATH TERMINAL PLATE ON ALL SETS AT THE FACTORY.

Fig. 9. Connections - Output Filter (Dwg. 149A420)

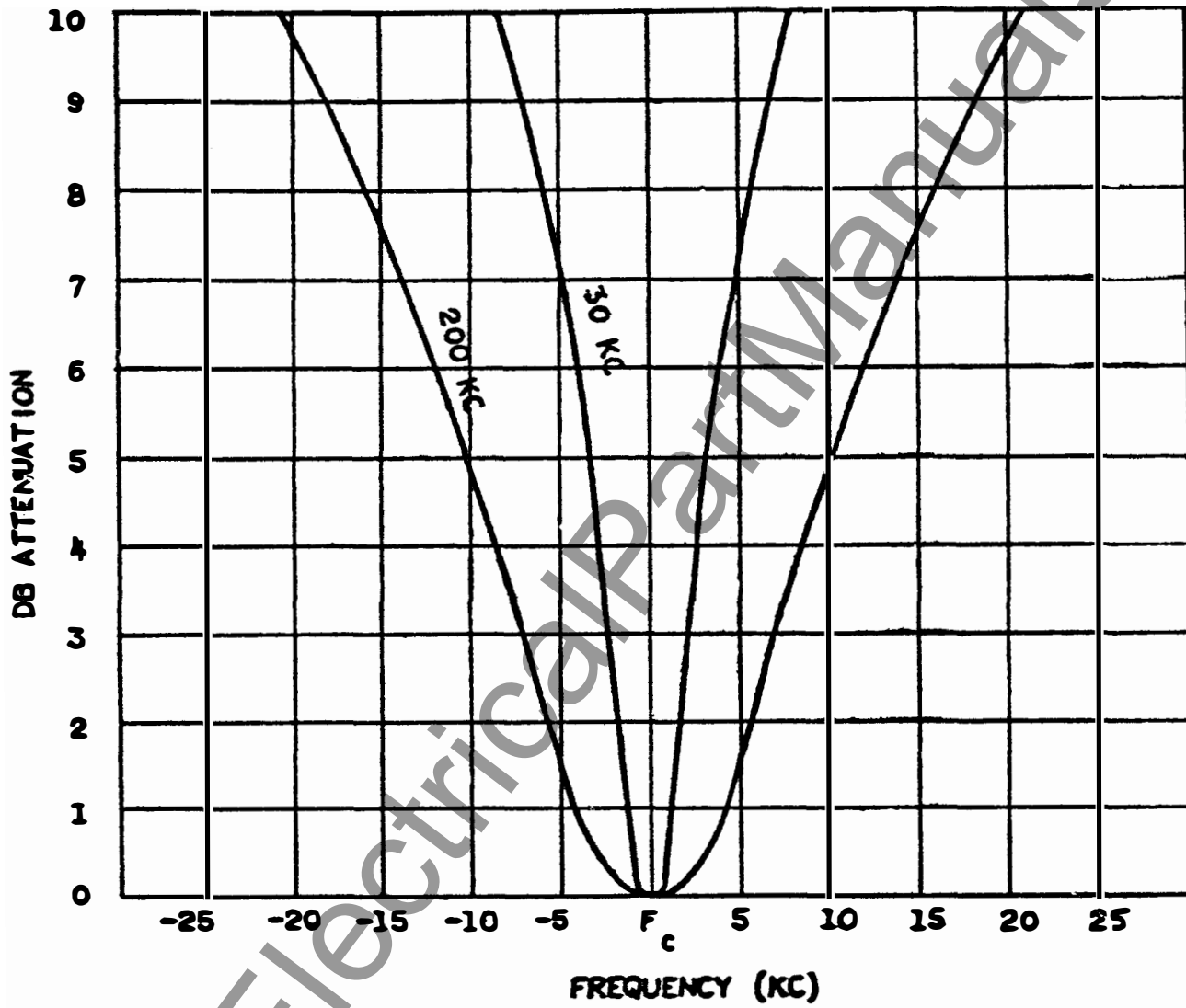

Fig. 10. Transmitter Output Filter Selectivity (Dwg. 377996)

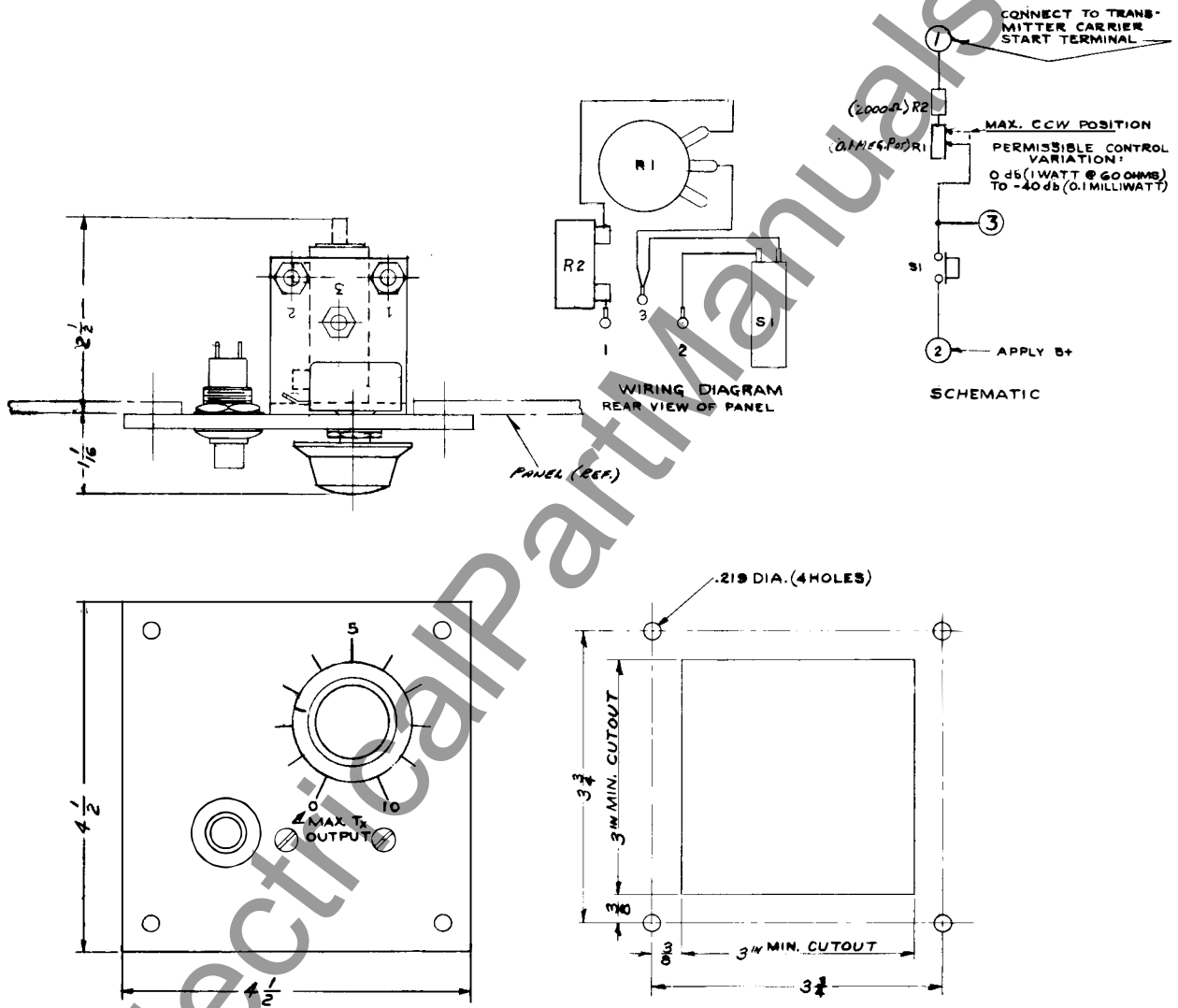

Fig. 11. Reserve Signal Detector Outline (Dwg. 329C703)

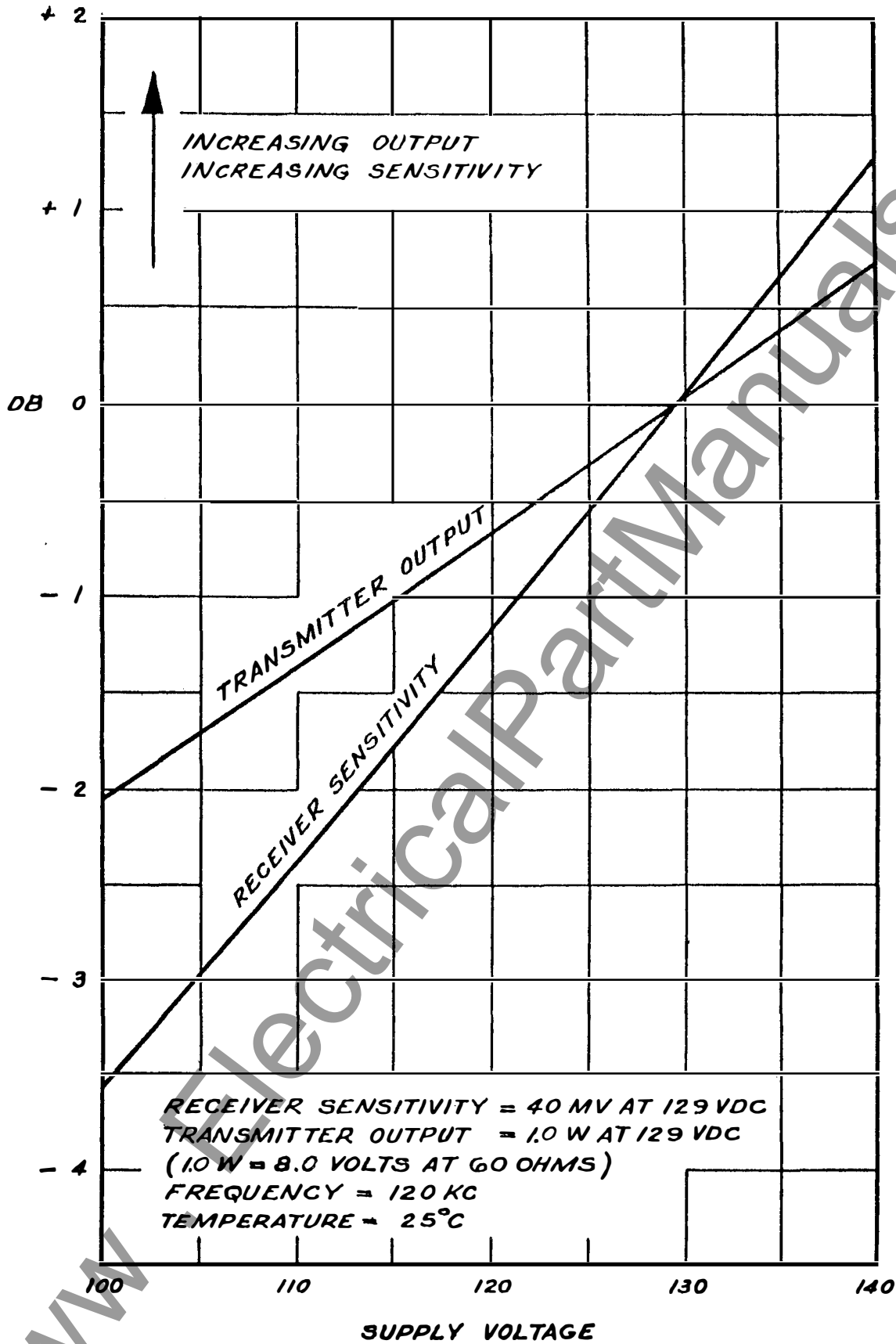

Fig. 12. Transmitter Output and Receiver Sensitivity Variations with Voltage (Dwg. 377999)

TRANSMITTER OUTPUT & RECEIVER SENSITIVITY
VARIATIONS WITH FREQUENCY

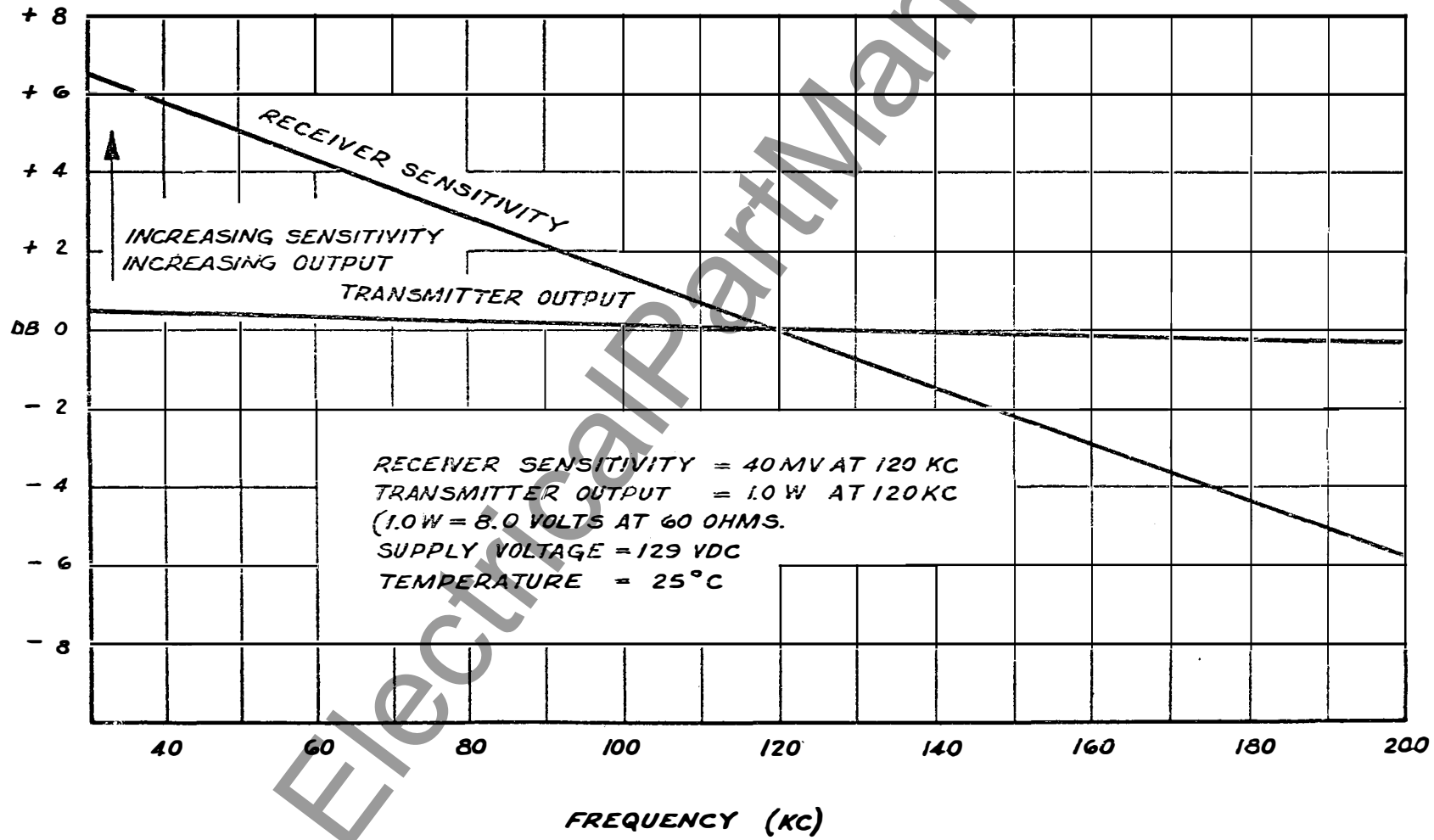

Fig. 13. Transmitter Output and Receiver Sensitivity Variations with Frequency (Dwg. 378000)

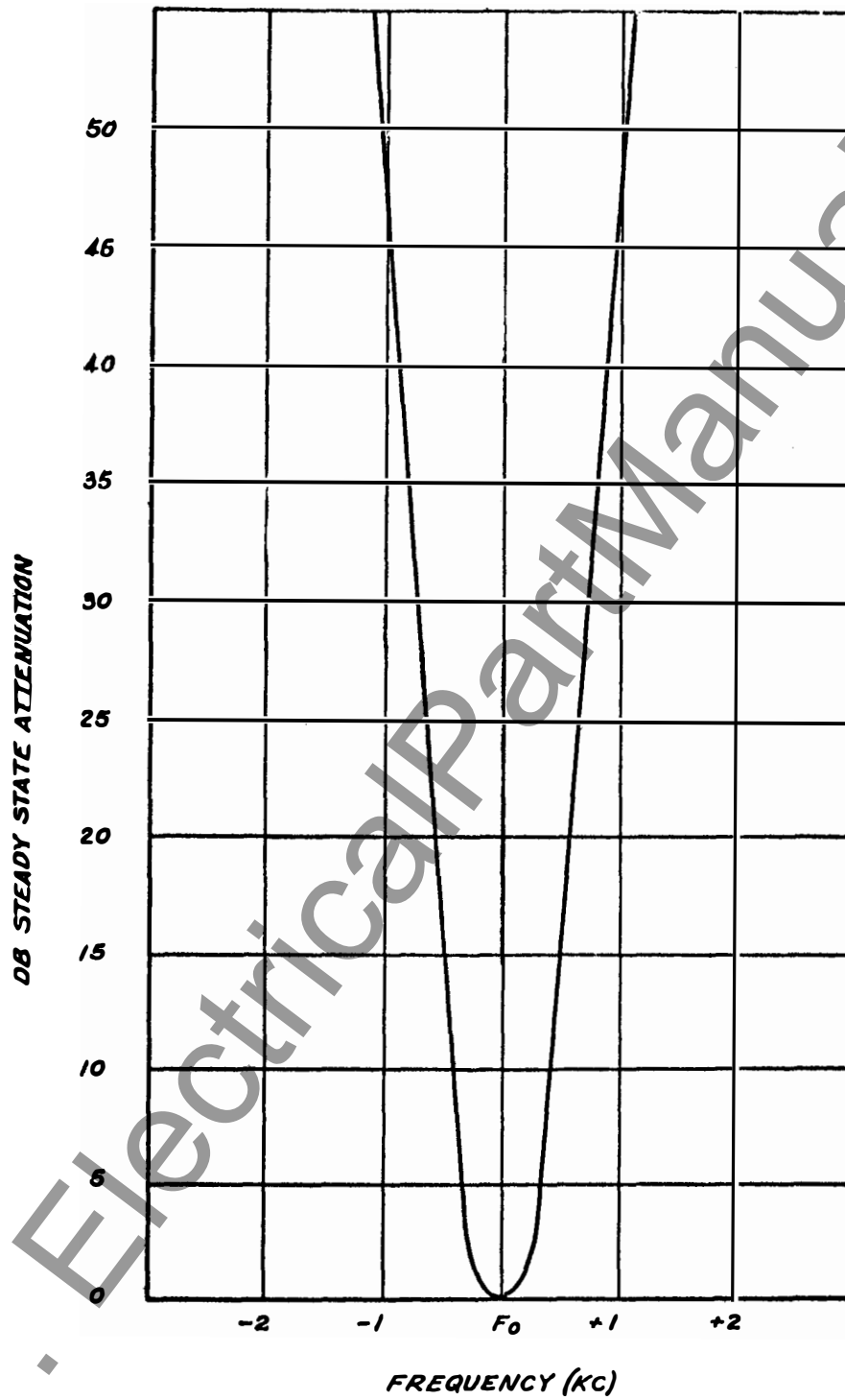
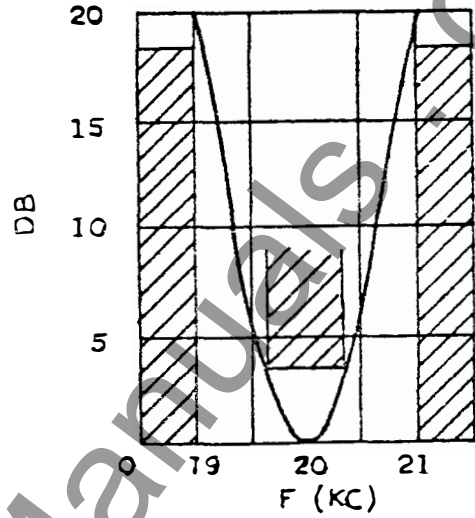
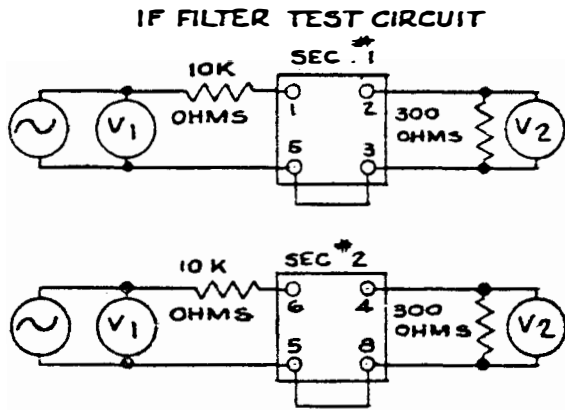
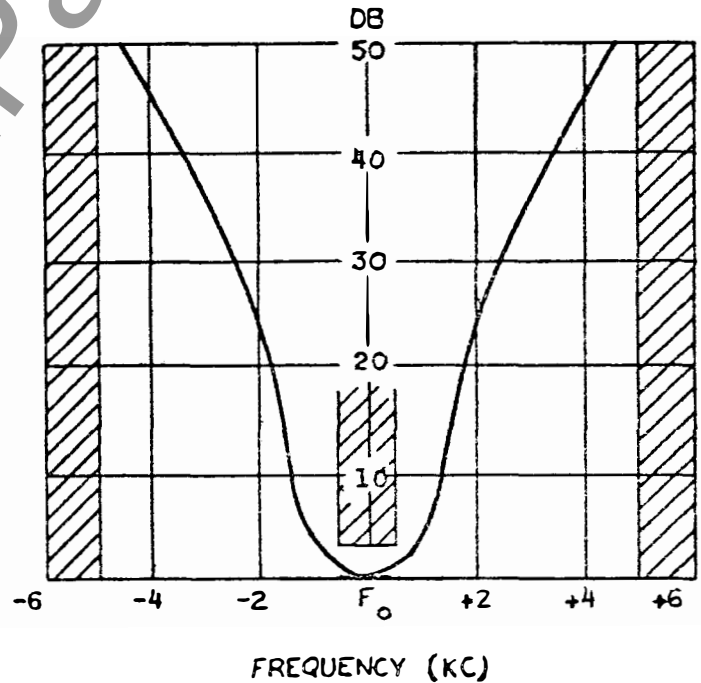
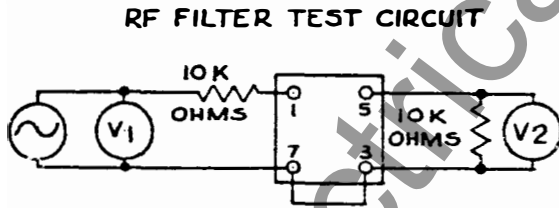

Fig. 14. Receiver Selectivity (Dwg. 377993)



Each section FL-2 requirement with typical selectivity curve
 Insertion loss 26 DB max.
 Including matching resistor.



FL-1 Requirement with typical selectivity curve at 120 KC. Insertion loss 18 DB max. Including matching resistor.

Fig. 15. Receiver Filter Limits (Dwg. 377995)

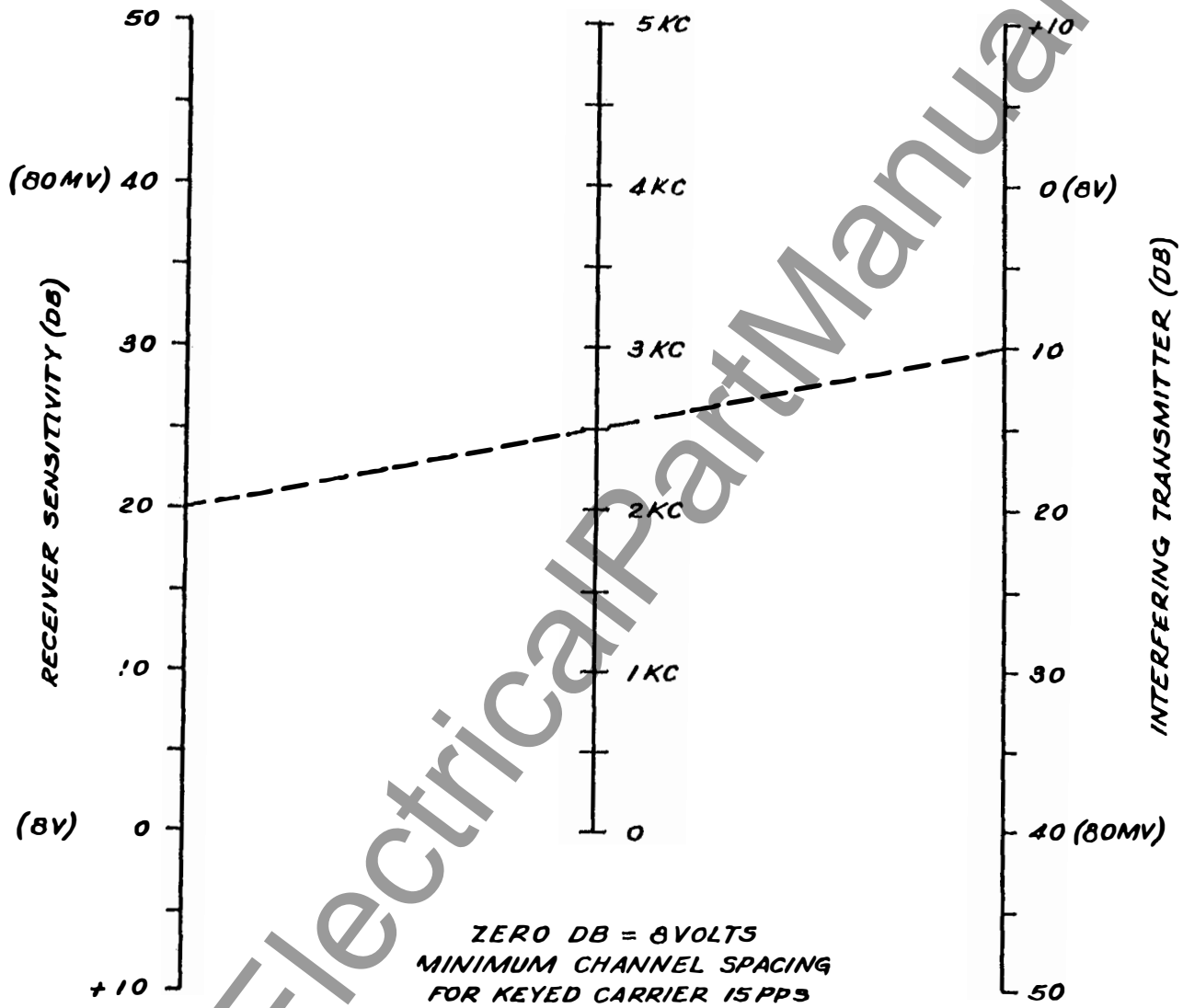
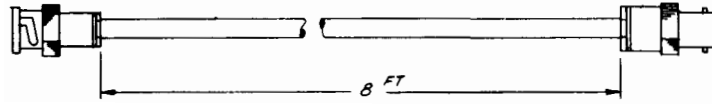
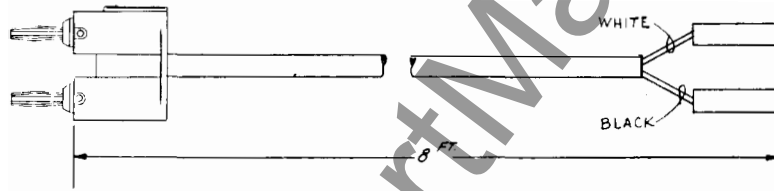

Fig. 16. Minimum Channel Spacing (Dwg. 377998)



Coaxial Lead...756D346 G02



Output Lead...756D346 G03

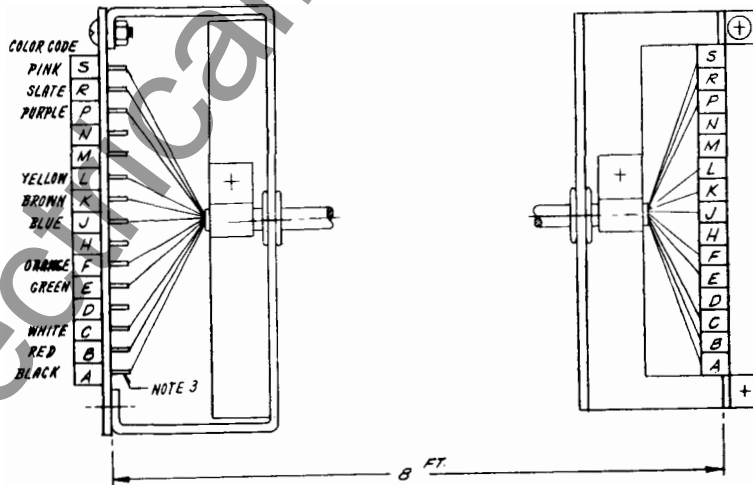

Main Harness...756D346 G04

Fig. 17. Test Harness - (Complete Set)



WESTINGHOUSE ELECTRIC CORPORATION
RELAY-INSTRUMENT DIVISION

NEWARK, N. J.

Printed in U.S.A.



INSTALLATION • OPERATION • MAINTENANCE I N S T R U C T I O N S

TYPE KR CARRIER RELAYING TRANSMITTER-RECEIVER

Flexitest Case Mounted —with provision for rear-mounter Voice Adapter Accessories.	Style
KR Reserve Signal Detector	470D167 GO2
250 Volt Resistor Unit	330C191 H01
Test Harness (Complete Set)	756D346 G01
Coaxial Lead	756D346 G02
Output Lead	756D346 G03
Main Harness	756D346 G04

TABLE OF CONTENTS

Introduction	Page 2	Adjustments	
Specifications	Page 2	Transmitter	Page 7
Description		Receiver	Page 7
General	Page 3	Reserve Signal Detector	Page 8
Mechanical	Page 3	250-Volt Resistor Unit	Page 8
Electrical		Frequency Change	Page 8
Transmitter	Page 4	Maintenance	Page 9
Receiver	Page 4	Application	Page 13
Transmitter Control Circuits	Page 5	Electrical Parts List	Page 14
Reserve Signal Detector	Page 5		
Communications	Page 5		
Relaying Control Circuits	Page 5		
Installation			
General	Page 6		
Connections			
External	Page 6		
Internal	Page 7		

LIST OF TABLES

Table	
1 D-C Pin Jack Measurements with Reference to B-	Page 10
2 Transistor DC Measurements with Reference to B-	Page 11
3 D-C Bleeder Measurements with Reference to B-	Page 12
4 Typical RF Signal Measurements for Receiver	Page 12
5 Typical RF Signal Measurements for Transmitter	Page 13

*SUPERSEDES I.L. 41-941.1B
Denotes change from superseded issue.

LIST OF ILLUSTRATIONS

Figure	References
1 Outline – Flexitest Case	540D753
2 Internal Schematic	540D780
3 Relaying Control Circuits (HZ/HZM)	1-329C704
4 Relaying Control Circuits (K-Dar)	3-329C704
5 Relaying Control Circuits (GCX/GCY).....	2-329C704
6 Component Location.....	540D781
7 Supervisory Control Receiver Connection.....	223B498
8 Connections, 48-250 volts and Supervisory Control.....	407C971
9 Transmitter Output Filter Connections	149A420
10 Transmitter Output Filter Selectivity.....	C377996
11 Reserve Signal Detector – Outline and Schematic	329C703
12 Transmitter Output and Receiver Sensitivity Variations with D-C Voltage	C377999
13 Transmitter Output and Receiver Sensitivity Variations with Frequency.	C378000
14 Receiver Selectivity	C377993

15 Receiver Filter Limits	C377995
16 Minimum, Channel Spacing	C377998
17 Test Harness	756D346

CAUTION The voltages encountered in this equipment are dangerous to life. To be safe, disconnect the power source and close the grounding switch when servicing the equipment.

INTRODUCTION

The Type KR Relaying Transmitter-Receiver is designed for Distance Relaying, Telemetry, Supervisory Control and Sleet Detection. Facilities are provided for a plug-in type voice adapter. The basic design is for operation from 125-volt station batteries. However, the apparatus may also be operated from 48-volt or 250-volt station batteries by means of various internal connections. These various connections as well as most of the adjustments are made at the factory, although they can be changed in the field.

Although designed primarily for operation with Westinghouse protective relays, this apparatus may also be coordinated with other types of directional-distance relays and with most other contact keyed devices.

SPECIFICATIONS

Frequency Range.....	30-kc to 200-kc
Channel Attenuation Rating	40-db
Transmitter Power Output	1.0 watt at standard conditions (see Figs. 12 and 13). 0.5 watt with a 48-volt d-c supply.
Transmitter Harmonic Output	At least 46-db below fundamental.
Transmitter Output Impedance.....	Matches one 60-ohm coax. cable. (Suitable for 50-70 ohm cable.)
Transmitter Output Filter Selectivity	See Fig. 10
Transmitter and Receiver Oscillator and Frequency Stability	From -20° C to +50° C with simultaneous voltage variations from 100 to 140 VDC, the frequency remains with 0.01%.

Permissible Battery Voltage Ripple	7-1/2%
Ambient Temperature Range	-20°C to +50°C.
Non-Operating Temperature Range	-40°C to +70°C
Receiver Sensitivity	0.04 volts at standard conditions (see Figs. 10 and 18).
Receiver Selectivity	See Fig. 14
Receiver Signal-to-Noise Ratio Requirements	12-db
Minimum Channel Spacing	See Fig. 16
Power Input	115-ma at 48 VDC, 200-ma at 125 VDC, 1.28 amperes at 250 VDC.
Carrier On-Off Keying	Requires one pair of contacts capable of keying 8-ma DC at an open circuit voltage of 125 VDC.
Weight (With Flexitest Case)	Approximately 16-lbs.

CAUTION Refer application to Westinghouse when other transmitters are to be connected to the same coax cable as certain conditions may result in damage to the output transistors.

NOTE Standard conditions are taken as 120-volts, 120-kc and 25°C.

DESCRIPTION

General

This completely transistorized carrier-apparatus is a result of extensive field and laboratory tests. From these tests, it was proven that transistors provide superior reliability over tubes. In addition, the latest printed circuit and filter techniques have improved performance and greatly decreased the size. The expected long life of transistors as compared with vacuum tubes will reduce maintenance costs, and the low power requirements will produce important savings in battery and charger requirements.

Transistors perform the same functions as vacuum tubes. However, tubes operate by the flow of electrons in a vacuum between elements, while transistors depend upon the movement of electrons in a solid. This leads to a more rugged type of construction. Most transistors are made from either germanium

or silicon semi-conductor materials. The junction transistor consists of a thin slice of germanium or silicon with three different regions produced by introducing specific amounts of impurities. A thin wire is connected to each region. One outer region is called the emitter, the other the collector, and inserted between them is the base. These correspond roughly to the cathode, plate, and grid of a vacuum tube.

The transistors in this equipment are of the junction type, and both NPN and PNP configurations are used. In the NPN transistor, the majority of the current is carried by electrons. In the PNP transistor there is a deficiency of electrons. These deficiencies are known as "holes". For practical purposes holes may be considered as positively charged "electrons", and these provide most of the current flow in PNP units. In order to obtain maximum efficiency and reliability, both types are used in this equipment.

Silicon transistors are used in the transmitter and receiver output circuit in order to stabilize critical circuit performance at elevated temperatures.

Mechanical

This apparatus is supplied in a Flexitest case and may be either flush or projection mounted in

order to match other switchboard equipment. The outline dimensions and also the drilling plan for flush and projection mounting are shown by Fig. 1. The majority of the parts are mounted on a printed circuit board. This board may be readily removed as follows:

1. Remove the two output plugs from the red and black jacks.
2. Disconnect the receiver input coaxial cable connector.
3. Loosen the two screws at the top of the board.
4. Loosen the two screws at the bottom of the board and pull them out as far as they will extend.
5. Pull board down to disengage the terminals and lift out.

The transmitter output filter may be removed by removing four mounting screws from the bottom of the case and disconnecting the coaxial cable.

Fig. 6. shows the location of major components such as potentiometers, jack, test points, crystals, transistors, etc. External connections and the Schematic Diagram are shown by Fig. 2. The numbered terminals shown as squares apply to the external terminals.

Provisions are made for plugging the Voice Adapter Unit in the rear of the relaying equipment. Octal socket marked X-4 on the rear of the set accommodates the adapter plug. A buckle type strap on each side of the adapter holds the unit in place after it has been plugged in. The normal projection for a rear mounted Voice Adapter is 3-inches beyond that of the relaying equipment. When the KR Relaying Unit is supplied with the adapter, a patch cord is available on separate order. This patch cord plugs into the telephone jacks on the adapter and provides an extension to a conveniently located terminal board.

The panel cutout information necessary for mounting the Sleet Detector is shown by Fig. 11. This unit consists of a potentiometer and pushbutton switch mounted on a small panel, itself suitable for switchboard mounting.

For 250-volt operation, separate auxiliary resistors are required, as shown in Fig. 8.

Electrical

Transmitter

The transmitter is made of four main stages in-

cluding an oscillator, driver, power amplifier, and an output filter. In the oscillator, the crystal is operated as a resonant circuit between the collector of one transistor and the base of the other. The feedback is supplied through a capacitor from the collector of the second transistor to the base of the first transistor. The frequency is independent of voltage or temperature changes of the transistors. Thus the frequency stability is the stability of the crystal.

The input to the driver stage Q-10 is controlled by potentiometer, R-42 which also controls the transmitter power output. In HZM relaying CARRIER STOP provides about +40 volts for blocking. This is applied to Q-10 through T-6. Diode CR-5 prevents damage to the transistor when this positive voltage is applied to the collector. For CARRIER START (when in the blocked position) a small positive voltage is applied to the collector of Q-10 by means of bleeder resistors R-67 and R-68.

The power amplifier consists of two transistors Q-12 and Q-15, which are operated as class B amplifiers in push-pull. Resistors R-52 and R-55 are for stabilization.

The output transformer, T-7, matches coaxial cables of 50 to 70 ohms.

Resistor R-66 tends to keep the source impedance constant to permit proper tuning of the output filter.

The output filter consists of coils L-1 and L-2, capacitors C-19 through C-22. The filter is tunable, and is provided to attenuate harmonics and other spurious outputs. It should be noted that the filter contains no shunt elements, resulting in a reverse impedance free of "across the line" resonances.

Receiver

The receiver is a superheterodyne in order to obtain constant selectivity regardless of the channel frequency. (See Fig. 14.) The major stages include an input filter, attenuator, oscillator, mixer, IF filters, IF amplifiers, detector and a D-C power output stage.

The input filter prevents undesired signals from producing the IF frequency.

The receiver sensitivity is adjusted by means of the continuously variable input control R-1 and by

connecting or disconnecting resistors R-73 and R-74 in the IF stages.

The receiver oscillator (Q-2 and Q-3) is basically the same as the transmitter oscillator. The frequency is 20-kc above the incoming signal frequency.

The receiver channel frequency is determined by the input filter and the oscillator crystal. The frequency may be changed readily since both the filter and the crystal are plug-in components.

Mixing is accomplished by feeding the incoming signal to the emitter and the receiver oscillator signal to the base of the mixer Q-1. Mixer oscillator requirements are met through adjustment of potentiometer R-4. Injection into two separate elements, base and emitter, provides a circuit capable of handling greater signal level variations than one in which injection is made into only a single element such as the base.

This receiver uses an IF frequency of 20-kc. The overall selectivity is determined primarily by the IF filter FL-2. Typical characteristics of this filter are shown in Fig. 15.

The IF amplifier consists of transistors Q-4, Q-5 and Q-6.

The detector is a full wave bridge rectifier. This rectifier in conjunction with the IF amplifier Q-6, provides the necessary power to drive the D-C power output stage Q-7.

The final output stage Q-7 will supply approximately 18 milliamperes to a standard 1700 ohm distance relay RRH coil and its associated 500 ohm alarm coil. It may also be used to drive other relay coils such as is shown by Fig. 7, Supervisory Control Connections.

Transmitter Control Circuits

In the standby condition, although the oscillator is running, the transmitter driver has no emitter bias which results in no output.

Positive voltage applied to terminal 15 supplies this bias through a voltage dividing network, and transmitter output results. The actual configuration of the network is a function of supply voltage and application (Relaying, Telemetry, etc.) and is

discussed in the Adjustments section.

Output may be stopped in several ways. The method used with K-DAR relays is to remove the positive voltage applied to terminal 15. In the case of distance relaying with Westinghouse HZ/HZM relays, application of a positive voltage to terminal 18 will stop the transmitter output. Output may also be stopped by removal of negative battery from terminal 18.

Reserve Signal Detector

The Reserve Signal Detector is shown by Fig. 11. Effectively R-1 is a remote transmitter output control. This control is obtained through varying the driver stage (Q-10) emitter bias, and is effective over a 40-db range of transmitter output. The detector is switched into service by S-1. By adjusting R-1 for a given receiver relay current at the far end of the channel, a relative measure of the channel attenuation may be obtained. This is discussed further in the section on Adjustments.

Communications

The transmitter output is reduced approximately 6-db when the Type KR voice adapter attachment is used. Relaying takes preference, and full output is obtained since full voltage is supplied to terminal 15.

Relaying Control Circuits

Figs. 3, 4 and 5 show simplified diagrams of the relaying control circuits.

1. K-DAR and GCY Relaying (Figs. 4 and 5)

The control of the carrier set is obtained through the CARRIER START and CARRIER STOP contacts. These contacts are shown in their normal standby condition.

The K-DAR or GCY relays operating from the voltage and current on the transmission line, detect and determine the direction of a line fault and thereby control the carrier transmitter and receiver.

The control of the carrier set is such as to start the transmission of carrier when fault power on the transmission line is flowing out of the line section being protected. Conversely, when fault power is flowing into this line section, the control is such as to block the transmitter and keep it from being turned on by secondary functions such as sleet detection

TYPE KR CARRIER SET

and communication, should these functions be in use at the same time. Should carrier be received from the remote station, the hold coil and alarm coil will energize through transistor Q-7 in the receiver.

When carrier start operation occurs, the CARRIER START contact opens applying a positive voltage (see Figs. 4 and 5) to terminal 15 of the carrier set. This puts a potential on the driver stage in the transmitter and also applies proper bias for the power amplifier.

When a carrier stop operation occurs, the CARRIER STOP contact closes, which removes B+ (terminal 15) from the driver and the power amplifier stages in the transmitter. CARRIER STOP, terminal 18, on the carrier set is permanently connected to terminal 14, for K-DAR and GCY relaying.

2. HZM Relaying (Fig. 3)

The control of the carrier set is effected by the CARRIER START and the CARRIER STOP contacts. These contacts are shown in their normal standby condition.

The HZ-HZM relays operating from the voltage and current on the transmission line, detect and determine the direction of a line fault and thereby control the carrier transmitter and receiver.

The control of the carrier set is such as to start the transmission of carrier when fault power on the transmission line is flowing out of the line section being protected. Conversely, when fault power is flowing into this line section, the control is such as to block the transmitter and keep it from being turned on by secondary functions such as sleet detection and communication, should these functions be in use at the same time. Should carrier now be received from the remote station, the hold coil and alarm coil will energize through transistor Q-7 in the receiver.

When carrier start operation occurs, the CARRIER START contact closes applying the full battery supply voltage to terminal 15 of the carrier set. This puts a potential on the driver stage in the transmitter and also applies proper bias for the power amplifier.

When a carrier stop operation occurs, the CARRIER STOP contact opens. This applies a positive voltage (see Fig. 3) to terminal 18 which blocks the driver stage and the power amplifier stage

It is possible under certain conditions that the signals from two transmitters, attempting to block a third receiver, would be of such amplitude, phase and frequency as to cause the RRH coil current to "pulsate". It would then be possible to have a false trip.

In the case of the KR set for relaying 3-terminal lines, the transmitter frequencies (to avoid this possibility of false trip) should be separated by 100 cycles. All receivers and one transmitter would be for the desired center frequency. One of the other transmitters would be 100 cycles above, the other 100 cycles below this center frequency.

INSTALLATION

General

Upon receipt of a unit, whether shipped separately or in an assembly, an immediate inspection should be made. Carefully check for damage or shortages.

For necessary clearances and mounting dimensions, see the following illustrations:

Flexitest Case Mounting..... Fig. 1

Sleet Detector..... Fig. 11

Connections

External

The external connections will vary slightly depending on the application, but in general will be along the lines described as follows: (Refer to the Schematic Diagram, Fig. 2.)

Terminals	11.....	Ground
	12.....	Coaxial Cable
	13 and 19.....	Supervisory Preference Contacts
	14.....	B- "CARRIER STOP" return
	15.....	Battery positive through carrier start contacts
	16.....	Battery positive for alarm cutoff (used with communication)
	17.....	B-
	18.....	Carrier Stop for HZM Relaying
	19.....	B+
	20.....	Relay Coil

CAUTION If the transmitter output load is removed while the transmitter is energized, the transistors in

the power amplifier will be permanently damaged. A dummy load should be connected to the transmitter output if the coax is disconnected and the transmitter is to be energized.

When tuning line coupling equipment, short the coaxial cable to ground before changing taps on the Line Tuner or matching transformer.

Internal

Necessary internal connections are generally made at the factory, to customer order, before apparatus shipment. For reference purposes, these are outlined in the following tabulation. Check the proper bleeder resistors before applying voltage to the equipment.

OPERATION	BLEEDER RESISTORS IN THE CIRCUIT
48-Volt K-DAR, HZM, and GCY Relaying, Telemetering, and Supervisory	R-47 and R-48
125-Volt K-DAR and GCY Relaying	R-45, R-47 and R-48
125-Volt HZM Relaying, Telemetering, and Supervisory	R-41, R-45, R-47 and R-48
250-Volt K-DAR and GCY Relaying	R-45, R-47 and R-48
250-Volt HZM Relaying, Telemetering, and Supervisory	R-39, R-40, R-41, R-45, R-47 and R-48

Various combinations of the inductors and capacitors of the transmitter output filter are required depending on the channel frequency. These are tabulated in Fig. 9.

Adjustments

This apparatus is generally tuned to and tested at the specified channel frequency before shipment. Final adjustments must be made in the field and are described in the following paragraphs. Fig. 6 shows the locations of the various controls.

Transmitter

1. Disconnect the coaxial cable and replace with a 50, 60, or 70 ohm non-inductive resistor depending on the characteristic impedance of the cable used.

2. Fig. 9 shows typical output filter connections for various frequency ranges. In some cases it may be necessary to use either a higher or lower range to tune the filter to resonance.

3. Insert fuses F-1 and F-2 to apply power to the apparatus.

4. Connect an A-C Vacuum Tube Voltmeter (VTVM) across the non-inductive load.

5. Unblock the transmitter by closing the CARRIER TEST SWITCH. An alternative is to jumper battery positive to terminal 15.

6. Beginning with the output control R-42 at the maximum counterclockwise position, advance it clockwise until a reading appears on the VTVM. Tune capacitor C-19 for a maximum voltmeter reading.

7. While increasing R-42, tune the output filter for maximum output until the output across the resistor is approximately 8 volts. (See Figs. 12 and 13.) (Approximately 5.5-volts when operating from 51-volt station battery.)

8. Open the test switch and reconnect the coaxial cable.

Receiver

1. The oscillator output control R-4 is pre-set at the factory. However, should any of the oscillator components be changed (including the transistors and the crystal) R-4 will require adjustment.

a. Connect an A-C VTVM to jacks J-3 and J-4.

b. Adjust R-4 for a 0.3 volt reading on the meter.

2. The unit is shipped to have a gain of approxi-

mately 250 millivolts (to produce 10 ma relay current) with input control R-1 in maximum clockwise position. About 10-db additional gain or 80 millivolt sensitivity can be obtained by clipping out resistor R-74, which is connected to the base of Q-4 and the B+ supply for the IF. Approximately 10-db gain or 25 millivolt sensitivity can be obtained by clipping out resistor R-73, which is connected to the base of Q-5 and the B+ supply for the IF. Resistor R-71 has been selected at the factory to provide an overall gain of approximately 25 millivolts.

a. Sensitivity Adjustment for Noise

If the maximum on-frequency noise level is known or can be measured, the receiver can be adjusted for this level. Disconnect the coaxial cable and connect a 60-ohm non-inductive resistor and a VTVM across terminals 11 and 12. Energize the transmitter and output control R-42 for the same output as the maximum noise. Then adjust the receiver input control R-1 to obtain 1-ma output current. If it is impossible to obtain 1-ma output current with control R-1 in the maximum clockwise position, then clip out resistor R-74, which is connected to the base of Q-4. If the gain is still insufficient, clip out resistor R-73, which is connected to the base of Q-5. After completing the adjustment of R-1, restore the transmitter to full output.

b. Sensitivity Adjustment for Remote Signal

When the maximum on-frequency noise is unknown and cannot be conveniently measured, the receiver may be adjusted for the remote signal. First determine the channel attenuation using a Sierra voltmeter or some other convenient method. Disconnect the coaxial cable and connect a 60-ohm non-inductive resistor and a VTVM across terminals 11 and 12. Add 15-db to the channel attenuation. This compensates for average variations such as channel and voltage variations. For example, if the channel attenuation is 5-db, add this to the 15-db making a total of 20-db. Taking this from 8 volts output of the transmitter, the receiver should then be set for a sensitivity of 0.8 volts. To do this, adjust the transmitter output control R-42 for 0.8 volts and then adjust the receiver input control so as to obtain 10-ma output current. If it is impossible to obtain 10-ma output current with control R-1 in the maximum clockwise position, clip out resistor R-74, which is connected to the base of Q-4. If the gain is still insufficient, clip out resistor R-73, which is connected to the base of Q-5. After completing the

adjustment of R-1, restore the transmitter to full output.

It must be kept in mind that the two preceding adjustment procedures are to be used as a guide and will cover the majority of cases; however, cases may arise where conditions change. For example, if the adjustment is made per part a., the noise may increase due to various reasons such as bad insulators, which would require adjusting the receiver to be less sensitive. In the adjustment of part b., the attenuation may increase due to sleet or line switching, which would necessitate increasing the sensitivity of the receiver.

Reserve Signal Detector

Due to different types of operation and supply voltages, it is not practical to have a calibrated dial for this unit. However, calibration may be made at installation by recording transmitter output (either in db or volts) at various knob settings of the detector unit. Then, by adjusting the knob so as to obtain 10 milliamperes relay current at a remote receiver, any increase or decrease in line attenuation may be noted as the difference between the original setting, and the setting required to obtain the given 10 milliamperes.

250-Volt Resistor Unit

With the apparatus energized, adjust R-4 in the 250-volt resistor unit so as to obtain 125-volts at terminals 17 (B-) and 19 (B+) on the relaying set.

Frequency Change

If the frequency is changed in the field, it is necessary to change the input filter FL-1 to the desired channel frequency. This filter is of the plug-in type and may be removed by unsnapping the clamp and pulling the filter out. The transmitter oscillator crystal Y-2 must be changed to the desired channel frequency. The receiver oscillator crystal Y-1 must be changed to the desired channel frequency plus 20 kc. Figure 9 shows the connections for the transmitter output filter. It is necessary to unsolder the existing connections and make the new connections per the chart. After completing the preceding, the tuning procedure as described under Adjustments for transmitter and receiver should then be followed.

Note also that capacitors C2 and C9 in the transmitter and receiver crystal oscillator circuits, respectively, may have to be changed. For fre-

quencies below 110 kc, these capacitors are 270 mmf. each. For frequencies of 110 kc and above, the capacitors are 140 mmf. each.

CAUTION Turn power OFF before removing filters or transistors, as high transient currents may cause permanent damage to the transistors.

MAINTENANCE

Voltage values should be recorded after adjustment in order to establish reference values which will be useful when checking the apparatus. The readings will remain fairly constant over an indefinite period unless a failure occurs. However, if transistors are changed, there may be considerable difference in these readings without the overall performance being affected.

Typical voltage and current values are given as follows. Voltages should be measured with VTVM. Readings may vary as much as $\pm 20\%$.

In the following paragraphs, the transmitter may be unblocked (transmitting) by closing the CARRIER START circuit in the case of HZM relaying, and by opening the CARRIER START circuit in the case of K-DAR and GCY relaying.

1. For D-C pin jack measurements with reference to B-, refer to Table 1.

2. For transistor D-C measurements with reference to B-, refer to Table 2.

3. For D-C bleeder measurements with reference to B-, refer to Table 3.

4. For typical RF signal measurements for receiver, refer to Table 4.

5. For typical RF signal measurements for transmitter, refer to Table 5.

6. Removal of Printed Circuit Board from Flexitest Case.

To remove the printed circuit board, unplug J-15 and J-16 located near the output filter. Loosen the two screws inside the case near the top. Loosen the slotted thumb screws at the lower end of the board and pull these screws out as far as they will extend. Also remove the receiver coaxial cable plug.

Pull board down so as to disengage the terminals, and lift out.

7. Removal of the Output Filter

After the printed board has been removed, remove the screws on the outside of the case at the bottom. Lift out filter and disconnect the coaxial cable.

8. Receiver Filters

Fig. 15 shows typical receiver selectivity curves both RF and IF. If the filters are checked in a test setup, it is necessary to use an accurate signal generator or preferably a signal generator and a frequency counter.

9. Minimum Test Equipment for Installation

- a. Milliammeter 0-25 ma DC.
- b. 60-ohm 5-watt non-inductive resistor.
- c. A-C Vacuum Tube Voltmeter (VTVM). Voltage range 0.003 to 30 volts, frequency range 60 cycles/sec to 230-kc, input impedance 7.5 megohms.
- d. D-C Vacuum Tube Voltmeter (VTVM)

Voltage Range: 0.15 to 300 volts
Input Impedance: 7.5 megohms

10. Desirable Test Equipment for Apparatus Maintenance

- a. All items listed in Sections 8 and 9.
- b. Signal Generator

Output Voltage: up to 8 volts
Frequency Range: 20-kc to 230-kc
- c. Oscilloscope
- d. Ohmmeter
- e. Capacitor checker
- f. Test harness (See Fig. 17)

TABLE 1

D-C PIN JACK MEASUREMENTS WITH REFERENCE TO B-

Description	Jack	CONDITION A Tx-Blocked †† Rx-No Signal		CONDITION B Tx-Blocked Rx-With Signal		CONDITION C Tx-Unblocked Rx-No Signal	
		129 VDC	51 VDC	129 VDC	51 VDC	129 VDC	51 VDC
RF Input	J-2	0	0	0.3 V	0.3 V		
DC Q-1 Base	J-3	20 V	20 V	20 V	20 V		
DC R _x B+	J-4	20 V	20 V	20 V	20 V		
DC R _x Osc	J-5	7 V	7 V	7 V	7 V		
DC Q-5 Base	J-6	20 V	20 V	20 V	20 V		
B-	J-7						
DC-P1-E	J-8	110 V	32 V	110 V	32 V	110 V	32 V
DC-Q-7 Base	J-9	69 V	0 V	78 V	2.3 V	66 V	0.3 V
DC Q-7 Emit	J-10	70 V	1.0 V	78 V	1.4 V	66 V	1.0 V
DC T _x Osc	J-11	7 V	7 V	7 V	7 V	7 V	7 V
B+	J-12	129 V	51 V	129 V	51 V	129 V	51 V
DC Q-10 Base	J-13					18 V	18 V
DC Q-10 Emit	J-14					18 V	18 V
RF ma out	J-15					130 ma	130 ma
DC ma RRH and ALARM				18 ma	13 ma†		

† With 2000 ohm resistor and Sigma relay.

†† Tx = transmitter, Rx = receiver

TABLE 2

TYPICAL TRANSISTOR DC MEASUREMENTS WITH REFERENCE TO B-

Transistor	Condition A Tx-Blocked Rx-No Signal (Volts)			Condition B Tx-Blocked Rx-With Signal (Volts)			Condition C Tx-Unblocked Rx-No Signal (Volts)		
	E†	B†	C†	E†	B†	C†	E†	B†	C†
Q-1	20.0	20.0	0.38	20.0	20.0	0.4			
Q-2	7	7.2	1.8	7	7.2	1.8			
Q-3	6.2	8.0	2	6.2	8	2.0			
Q-4	20.0	20.0	2.6	20.0	20.0	2.8			
Q-5	20.0	20.0	2.6	20.0	20.0	2.8			
Q-6									
129 VDC	110	110	129	115	114	129			
51 VDC	32	32	51	32	32	51			
Q-7									
129 VDC	70	68	129	78	80	86			
51 VDC	1.0	0	51	1.4	2.2	7.0			
Q-8	6.2	8	2	6.2	8	2	6.2	8	2
Q-9	7	7.2	1.8	7	7.2	1.8	7	7.2	1.8
Q-10††							18	18	0.4
Q-12††							0.27	0.20	50
Q-15††							0.27	0.20	50

† E-Emitter; B-Base; C-Collector.

†† With respect to term F' on printed board.

TABLE 3

D-C BLEEDER MEASUREMENTS WITH REFERENCE TO B-

Measurement	129 VDC			51 VDC		
	A†	B†	C†	A†	B†	C†
Junction R-61 and R-62 (J-8)	110V	110V	110V	32V	32V	32V
Junction R-61 and R-27 (J-10)	70V	78V	66V	1.0V	1.4V	1.0V
Junction R-27 and R-60 (P1-P)	69V	77V	65V	0	0	0
Junction CR-8 and R-64 (P1-K)	58V	58V	58V	51V	51V	51V
Junction R-48 and R-47 (J-14)	—	—	18V	—	—	18V
Junction R-45 and R-47 (TP-9)	—	—	45V	—	—	51V
Junction R-45 and R-41 (TP-8)	—	—	98V	—	—	51V

†Conditions: A — Tx-Blocked, Rx-No Signal; B — Tx-Blocked, Rx-With Signal; C — Tx-Unblocked, Rx-No Signal.

TABLE 4
TYPICAL RF SIGNAL MEASUREMENTS FOR RECEIVER
(Made with 0.1 Volt at Terminal 5 of FL1)

Check Point	25 MV Sensitivity (Volts)	80 MV Sensitivity (Volts)	250 MV Sensitivity (Volts)
With Receiver Crystal Out			
FL1-5 to Gnd.	0.1	0.1	0.1
T1-1 to Gnd.	0.1	0.1	0.1
Q1-E to Gnd.	0.05	0.05	0.05
Q1-C to Gnd.	0.07	0.07	0.07
T3-1 to Gnd.	0.07	0.07	0.07
Q4-C to Gnd.	0.07	0.07	0.07
With Receiver Crystal In			
Q4-C to Gnd.	0.5	0.5	0.25
J6 to Gnd.	0.15	0.1	0.08
Q5-C to Gnd.	7.0	1.7	0.8
Q6-B to Gnd.	2.0	0.5	0.4
Q6-C to Gnd.	13.0	10.0	8.0
T4-1 to Gnd.	13.0	10.0	8.0
T4-3 to T4-4	4.5	3.5	2.5
J9 to J10 (DC)	0.74	0.75	0.65

TABLE 5

TYPICAL RF SIGNAL MEASUREMENTS FOR TRANSMITTER	
CHECK POINT	VOLTS
T5-1 to Gnd.	5.5
T5-3 to Gnd.	1.0
J13 to Gnd.	0.085
Q10-C to Gnd.	6.0
T6-2 to Gnd.	6.0
Q12-B to Gnd.	0.8
Q15-B to Gnd.	0.8
Q12-C to Gnd.	38.0
Q15-C to Gnd.	38.0
T7-5 to Gnd.	9.8
Output to Gnd.	8.0

APPLICATION

1. Receiver Selectivity (Fig. 14)

This shows a typical curve of the overall selectivity of the receiver under steady state conditions.

2. Transmitter Output Selectivity (Fig. 10)

Typical curves are shown so that approximate bandwidths for keying purposes can be determined for any carrier frequency between 30-kc and 200-kc.

3. Minimum Channel Spacing (Fig. 16)

This is a graph from which minimum channel spacing can be obtained provided the signal strength of the interfering transmitter and the sensitivity setting of the receiver are known. These can be obtained from calculations or by measurements.

For example, if the interfering transmitter voltage is measured (at the receiver) and found to be 2.5

volts, this would be 10-db down from 8 volts. This point can be located on the right hand column of the graph. Then, if the receiver sensitivity were set to operate on 0.8 volts or 20-db, this point would be located on the left hand column. A line could then be drawn through the two points as shown by the dotted line. The intersection of this line with the center line indicates the minimum channel spacing. In this case if the interfering signal is being keyed on-off, at 15 pps, the minimum spacing would be 2.5-kc.

4. Transmitter Output and Receiver Sensitivity Variations with Voltage (Fig. 12)

These curves show the variation of transmitter output and receiver sensitivity with changes in supply voltage, at 120-kc and 25°C. The increase and decrease in transmitter output above or below 1.0 watts may be obtained in db from the transmitter curve. 1.0 watts is about 8.0 volts with a 60-ohm load.

The increase and decrease in receiver sensitivity above or below 40 millivolts can similarly be

TYPE KR CARRIER SET

obtained in db from the receiver curve. 40 millivolts sensitivity represents the input signal required for proper operation.

5. Transmitter Output and Receiver Sensitivity Variations with Frequency (Fig. 13)

These curves show the variation of transmitter output and receiver sensitivity with variation in frequency, at a supply voltage of 129 VDC, and 25°C. They may be used in the same manner as Fig. 12.

6. Supervisory Control Connections (Fig. 7)

When supervisory control is used with relaying, the supervisory control relay coil is connected in

series with the RRH coil in place of the alarm relay. When supervisory control is used alone, a 1200-ohm resistor R3 is connected in series with the control relay coil by removing the jumper across R3, as shown in Fig. 7. In order to maintain proper mark space ratio, the relay bias current is adjusted for 9 milli-amperes as indicated.

The receiver RF filter and the IF filter limits are shown on Fig. 15. Both filters are of the plug-in type and the test circuits with pin connections are shown at the top of each curve. The IF filter is divided into two separate sections. The selectivity shown is for each section, and the pin connections for each section are also shown in the test circuit sketch.

ELECTRICAL PARTS LIST

CIRCUIT SYMBOL	FUNCTION	DESCRIPTION	MFR. CODE	MANUFACTURER'S DESIGNATION
<u>CAPACITORS</u>				
C-1	Rcvr. Bleeder	2.0 μ f, \pm 20%, 200 VDC, Paper	1	330C567 H11
†C-2	Rcvr. Osc. Feedback	140/270 μ f, \pm 20%, 500 VDC, Mica	1	330C566 H43 or 330C566 H57
C-3	Rcvr. Osc. Bleeder Bypass	0.02 μ f, MRC, 600 VDC, Disc	1	330C569 H47
C-5	Q-6 Emitter Bypass	1.0 μ f, \pm 20%, 200 VDC Paper	1	330C567 H09
C-6	Rcvr. Rectifier Bypass	Same as C-5		
C-7	B- to B+ Bypass	2 μ f, \pm 10%, 600 VDC, Paper	1	14C9400 H 18
C-8	B- to GND	1.0 μ f, \pm 10%, 1000 VDC, Paper	1	14C9400 H 17
†C-9	Xmtr. Osc. Feedback	Same as C-2		
C-10	Xmtr. Osc.	Same as C-3		
C-11	Key Filter	0.1 μ f, \pm 20%, 200 VDC, Paper	1	330C567 H02
C-12	Q-10 Emitter Bypass	0.25 μ f, \pm 20%, 200 VDC, Paper	1	330C567 H05
C-13	Q-10 Bleeder Bypass	Same as C-12		
C-14	PA Base Bypass	Same as C-12		

†Note: 140 μ f for osc. freq. 110-kc and above.
270 μ f for osc. freq. below 110-kc.

ELECTRICAL PARTS LIST

CIRCUIT SYMBOL	FUNCTION	DESCRIPTION	MFR. CODE	MANUFACTURER'S DESIGNATION
<u>CAPACITORS (Concluded)</u>				
C-18	PA Bleeder	0.5 μ f, \pm 20%, Paper	1	330C567 H06
C-19	Output Filter Tuning	500 μ f, Variable, Air	1	328C092 H01
C-20	Output Filter	390 μ f, \pm 5%, 2500 VDC, Mica	1	330C561 H15
C-21	Output Filter	680 μ f, \pm 5%, 2500 VDC, Mica	1	330C561 H21
C-22	Output Filter	1200 μ f, \pm 5%, 2500 VDC, Mica	1	330C561 H27
C-24	FL-2 Decoupling	Same as C-12		
C-25	Q-7 Emitter	12 mfd, \pm 20%, 200 VDC	1	187A177 H01
<u>CRYSTAL DIODES</u>				
CR-1	Bridge Rectifier	General Purpose, 1N63	1	584C433 H02
CR-2	Bridge Rectifier	Same as CR-1		
CR-3	Bridge Rectifier	Same as CR-1		
CR-4	Bridge Rectifier	Same as CR-1		
CR-5	Q-10 Collector	Same as CR-1		
CR-6	Q-7 Collector	Same as CR-1		
CR-7	Voltage Regulator	Type 1N768,	1	584C434 H02
CR-8	Voltage Regulator	Type 1N1369	1	584C434 H05
CR-9	Q-7 Collector	Type 1N1789	1	584C434 H08

ELECTRICAL PARTS LIST

CIRCUIT SYMBOL	FUNCTION	DESCRIPTION	MFR. CODE	MANUFACTURER'S DESIGNATION
<u>FUSE HOLDERS</u>				
FH-1	B-	For Type 3AGC Fuses	1	584C271 H02
FH-2	B+	Same as FH-1		
<u>FUSES</u>				
F-1	B-	3AGC 3/4 amp.	1	S#330C691 H12
F-2	B+	Same as F-1		
<u>FILTERS</u>				
FL-1	Rcvr. RF Bandpass Freq. to be specified by customer	30-kc to 60-kc 60-kc to 110-kc 110-kc to 200-kc	1 1 1	
FL-2	Rcvr. IF Bandpass	20-kc Fixed Freq.	1	
<u>CONNECTORS</u>				
J-1	Printed Circuit	Printed Circuit Female Plug	1	54-B-7125 H03
J-2	RF Input	UG-185-U	1	584C292 H07
J-3	Rcvr. Osc. Output	Terminal Studs	1	330C592 H01
J-4	Rcvr. Mixer-Amp Supply	Same as J-3		
J-5	Rcvr. Osc. Supply	Same as J-3		
J-6	Q-5 Base	Same as J-3		
J-7	B-	Same as J-3		
J-8	Q-6 Supply	Same as J-3		

ELECTRICAL PARTS LIST

CIRCUIT SYMBOL	FUNCTION	DESCRIPTION	MFR. CODE	MANUFACTURER'S DESIGNATION
<u>CONNECTORS (Concluded)</u>				
J-9	Q-7 Base	Same as J-3		
J-10	Q-7 Emitter	Same as J-3		
J-11	Xmtr. Osc. Supply	Same as J-3		
J-12	B+	Same as J-3		
J-13	Xmtr. Osc. Output	Same as J-3		
J-14	Q-10 Supply	Same as J-3		
J-15	Output Filter	Banana Tip Red	1	328C093 H01
J-16	Output Filter GND	Banana Tip Black	1	328C093 H02
P-1	Printed Circuit	Printed Circuit Male Plug	1	54-B-7126 H03
<u>INDUCTORS</u>				
L-1	Core and Coil Assembly	11 MH Total – 6 MH Tap (Part of FL-3)	1	329C450
L-2	Core and Coil Assembly	2.5 MH (Part of FL-3)	1	329C449
L-3	RF Choke	1.0 MH, 300 ma	2	R-300
L-4	RF Choke	Same as L-3		
<u>TRANSISTORS</u>				
Q-1	Rcvr. Mixer	Type 2N43 or Type 2N525	1	330C587 H07 (2N525) 330C587 H02 (2N43)
Q-2	Rcvr. Osc.	Type 2N414	1	330C587 H09

ELECTRICAL PARTS LIST

CIRCUIT SYMBOL	FUNCTION	DESCRIPTION	MFR. CODE	MANUFACTURER'S DESIGNATION
		<u>TRANSISTORS (Concluded)</u>		
Q-3	Rcvr. Osc.	Same as Q-2		
Q-4	Rcvr. IF	Same as Q-1		
Q-5	Rcvr. IF	Same as Q-1		
Q-6	Rcvr. IF	Type 2N332,	1	330C587 H06
Q-7	Rcvr. Output	Type 2N1156	1	330C587 H01
Q-8	Xmtr. Osc.	Same as Q-2		
Q-9	Xmtr. Osc.	Same as Q-2		
Q-10	Xmtr. Amp.	Same as Q-1		
Q-12	Xmtr. PA	Type 2N498	1	330C587 H12
Q-15	Xmtr. PA	Same as Q-12		
		<u>RESISTORS</u>		
R-1	Rec. Input	25 K, $\pm 20\%$, 1/4 W, Pot.	1	584C276 H23
R-2	Filter Matching	10 K, $\pm 10\%$, 1/2 W	1	330C595 H37
R-3	Filter Load	Same as R-2		
R-4	Rcvr. Osc.	1 K, $\pm 20\%$, 1/4 W, Pot.	1	584C276 H19
R-5	Rcvr. Voltage Divider	6.2 K, $\pm 5\%$, 1 W	1	330C666 H68
R-6	Q-2 Collector	1.2 K, $\pm 5\%$, 1/2 W	1	330C664 H51
R-8	Rcvr. Voltage Divider	30 K, $\pm 5\%$, 2 W	1	330C668 H84
R-9	Rcvr. Voltage Divider	Same as R-8		

ELECTRICAL PARTS LIST

CIRCUIT SYMBOL	FUNCTION	DESCRIPTION	MFR. CODE	MANUFACTURER'S DESIGNATION
		<u>RESISTORS (Continued)</u>		
R-10	Q-2 Base	Same as R-2		
R-11	Q-2 Base	100 K, $\pm 5\%$, 1/2 W	1	330C665 H05
R-12	Q-3 Collector	Same as R-6		
R-13	Q-3 Emitter	390 Ohms, $\pm 5\%$, 1/2 W	1	330C664 H39
R-14	Q-3 Base	Same as R-2		
R-15	Q-3 Base	Same as R-11		
R-16	Rcvr. Osc. Bleeder	2.2 K, $\pm 10\%$, 1/2 W	1	330C595 H41
R-17	Rcvr. Osc. Bleeder	18 K, $\pm 10\%$, 2 W	1	330C597 H40
R-18	Rcvr. Osc.	9.1 K, $\pm 5\%$, 1/2 W	1	330C664 H72
R-19	Q-4 Bias	100 Ohms, $\pm 5\%$, 1/2 W	1	330C664 H25
R-20	Q-4 Bias	Same as R-2		
R-21	Q-5 Bias	150 Ohms, $\pm 5\%$, 1/2W	1	330C664 H29
R-22	Q-5 Bias	Same as R-2		
R-23	Q-6 Bias	330 Ohms, $\pm 5\%$, 1/2 W	1	330C664 H37
R-24	Q-6 Bias	Same as R-2		
R-25	Q-6 Emitter	Same as R-19		
R-26	Q-7 Base	Same as R-6		
R-27	Q-7 Bias	20 Ohms, $\pm 5\%$, 1/2 W	1	330C664 H08
R-28	Xmtr. Osc. Bleeder	Same as R-18		
R-29	Xmtr. Osc. Bleeder	Same as R-17		
R-30	Xmtr. Osc. Bleeder	Same as R-16		

ELECTRICAL PARTS LIST

CIRCUIT SYMBOL	FUNCTION	DESCRIPTION	MFR. CODE	MANUFACTURER'S DESIGNATION
		<u>RESISTORS (Continued)</u>		
R-31	Q-8 Base	Same as R-11		
R-32	Q-8 Base	Same as R-2		
R-33	Q-8 Emitter	Same as R-13		
R-34	Q-8 Collector	Same as R-6		
R-35	Q-9 Base	Same as R-11		
R-36	Q-9 Base	Same as R-2		
R-37	Q-9 Collector	Same as R-6		
R-38	Key Filter	Same as R-23		
R-39	Buffer Voltage Divider	36 K, $\pm 5\%$, 2 W	1	330C668 H86
R-40	Buffer Voltage Divider	Same as R-39		
R-41	Buffer Voltage Divider	Same as R-2		
R-42	Xmtr. Osc. Output	Same as R-4		
R-43	Q-10 Bias	Same as R-23		
R-44	Q-10 Bias	33 K, $\pm 5\%$, 1/2 W	1	330C664 H85
R-45	Buffer Voltage Divider	15 K, $\pm 10\%$, 1 W	1	330C596 H39
R-47	Buffer Voltage Divider	6.8 K, $\pm 5\%$, 1/2 W	1	330C664 H69
R-48	Buffer Voltage Divider	15 K, $\pm 5\%$, 1/2 W		330C664 H77
R-49	PA Bias	27 K, $\pm 5\%$, 2 W	1	330C668 H83

ELECTRICAL PARTS LIST

CIRCUIT SYMBOL	FUNCTION	DESCRIPTION	MFR. CODE	MANUFACTURER'S DESIGNATION
		<u>RESISTORS (Concluded)</u>		
R-50	Xmtr. PA	Same as R-19		
R-52	Q-12 Emitter	10 Ohms, $\pm 5\%$, 1/2 W	1	330C664 H01
R-55	Q-15 Emitter	Same as R-52		
R-59	Xmtr. Bleeder	47 Ohms, $\pm 10\%$, 1/2 W	1	330C595 H09
R-60	Recvr. Bleeder	1 K, $\pm 5\%$, 25 W	1	584C416 H57
R-61	Recvr. Bleeder	600 Ohms, $\pm 5\%$, 25 W	1	584C416 H47
R-62	Recvr. Bleeder	350 Ohms, $\pm 5\%$, 25 W	1	584C416 H52
R-64	Xmtr. Bleeder	1200 Ohms, $\pm 5\%$, 25 W	1	584C416 H64
R-66	T-7 Load	560 Ohms, $\pm 5\%$, 2 W	1	330C668 H43
R-67	Xmtr. Blocking	10 Ohms, $\pm 5\%$, 2 W	1	330C668 H01
R-68	Xmtr. Blocking	10 K, $\pm 10\%$, 10 W	1	330C577 H01
R-69	Q-10 Emitter	Same as R-19		
R-70	FL2 Decoupling	470 Ohms, $\pm 10\%$, 1/2 W	1	330C595 H21
R-71	Q-4 Emitter	150 Ohms, $\pm 10\%$, 1/2 W	1	330C595 H15
R-72	Q-5 Emitter	68 Ohms, $\pm 10\%$, 1/2 W	1	330C595 H11
R-73	Q-5 Base	180 Ohms, $\pm 10\%$, 1/2 W	1	330C595 H16
R-74	Q-4 Base	2.7 K, $\pm 5\%$, 1/2 W	1	330C664 H59
R-75	Q-4 Collector	22 K, $\pm 10\%$, 1/2 W	1	330C595 H41
R-76	Q-5 Collector	Same as R-75		

ELECTRICAL PARTS LIST

CIRCUIT SYMBOL	FUNCTION	DESCRIPTION	MFR. CODE	MANUFACTURER'S DESIGNATION
<u>TRANSFORMERS</u>				
T-1	Rcvr. Input	Impedance Ratio 10 K: 10K	1	S#1962798, L-633005
T-2	Rcvr. Osc.	Impedance Ratio 10 K: 400 ohms	1	S#1962797, L-633003
T-3	Rcvr. Mixer	Impedance Ratio 25 K: 300 ohms	1	S#1962697, L-592171
T-4	IF Output	Impedance Ratio 4 K: 500 ohms	1	S#1962693, L-592289
T-5	Xmtr. Osc.	Same as T-2		
T-6	Xmtr. Buffer	Impedance Ratio 10 K: 400 ohms CT	1	S#1962698, L-592170
T-7	Xmtr. Output	Impedance Ratio 1930: 60	1	S#1962694, L-633000
<u>TEST POINTS</u>				
TP-1	R-5	Terminal studs	1	330C592 H02
TP-2	R-8	Same as TP-1		
TP-3	R-17	Same as TP-1		
TP-4	R-18	Same as TP-1		
TP-5	R-28	Same as TP-1		
TP-6	R-39 & R-40	Same as TP-1		
TP-7	R-41	Same as TP-1		
TP-8	R-45	Same as TP-1		
TP-9	R-47	Same as TP-1		

ELECTRICAL PARTS LIST

CIRCUIT SYMBOL	FUNCTION	DESCRIPTION	MFR. CODE	MANUFACTURER'S DESIGNATION
<u>SOCKETS</u>				
X-1	FL-1	Octal	1	330C689 H01
X-2	FL-2	Same as X-1		
X-4	Rear Mounted Voice Adaptor	Same as X-1		
XY-1	Rec. Y-1	Crystal	1	584C606 H01
XY-2	Xmtr. Y-2	Same as XY-1		
<u>CRYSTALS</u>				
Y-1	Rcvr. Osc.	Specify Channel Freq. Plus 20-kc	1	328C083
Y-2	Xmtr. Osc.	Specify Freq. Same as Channel Frequency	1	328C083
<u>RESERVE SIGNAL DETECTOR</u> (S#470D167G02)				
R-1	Resistor, Level Control	100 K, 2 W, Pot.	1	51-D-1976 H17 (S#1475074)
R-2	Resistor, Limiting	2000 ohms, 2" tube.	1	1267296
S-1	Test Switch	SPST Normally Open	1	327C854 H01

LIST OF MANUFACTURERS

1. Westinghouse Electric Corporation
2. National Co., Inc., Malden, Mass.

TYPE KR CARRIER SET

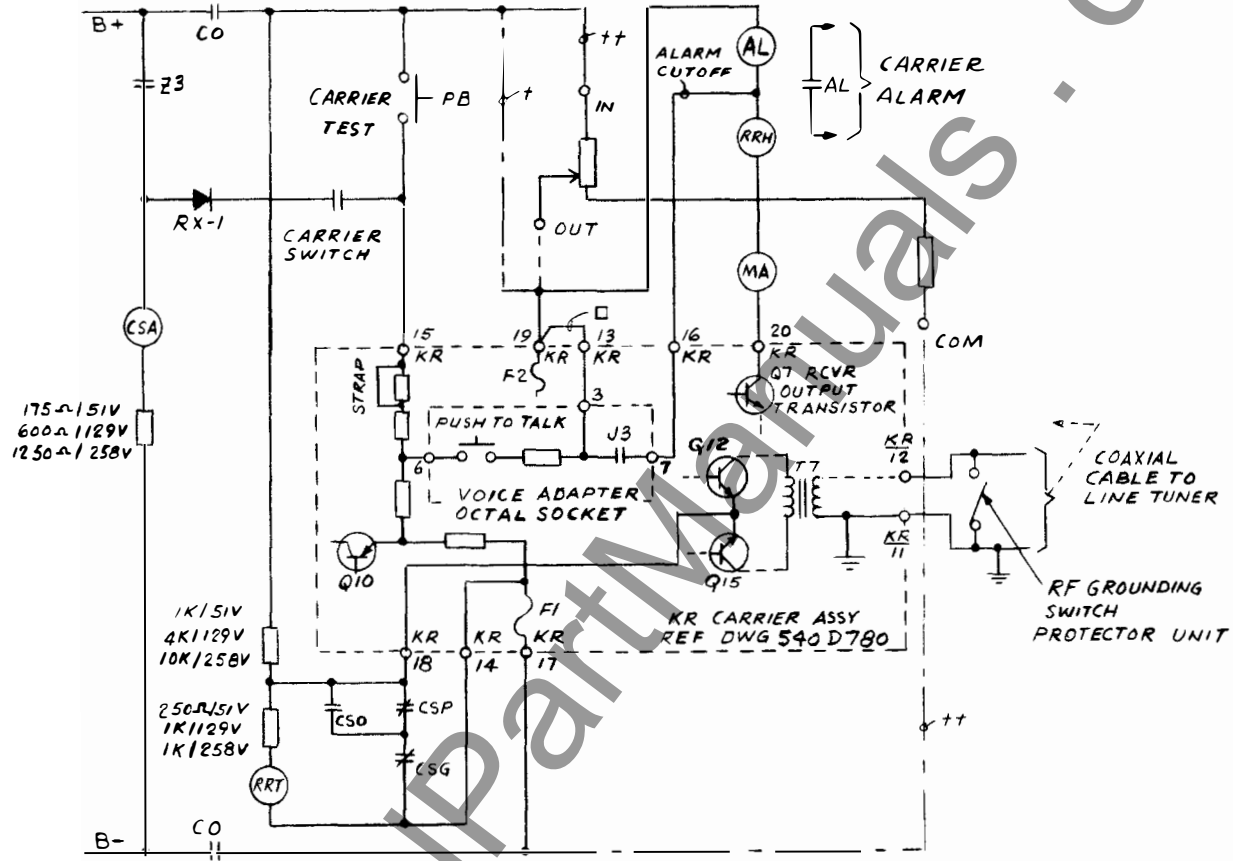

REQUIREMENTS FOR HZ/HLM RELAYING

SUPPLY VOLTAGE	CARRIER START	CARRIER STOP	STRAP
51VDC	+51V, 7MA	+28V	IN
129VDC	+129V, 8MA	+40V	IN
258VDC	+258V, 8MA	+40V	OUT

- NOTES
- + FOR 51 & 129 VDC SUPPLY.
 - ++ FOR 258 VDC SUPPLY USE 330C191H01 RESISTOR UNIT REF DWG 223B497
 - FOR SUPERVISORY CONTROL PREFERENCE CONTACTS.

- KR RELAYING TRANSMITTER / RECV EXTERNAL CONNECTIONS
- TERMINAL - CONNECTION
- 11 GROUND
 - 12 COAXIAL CABLE
 - 13 SUPERVISORY PREFERENCE CONTACT
 - 14 CARRIER STOP B- RETURN
 - 15 CARRIER START (POSITIVE)
 - 16 ALARM CUTOFF FOR COMMUNICATIONS
 - 17 B MINUS
 - 18 CARRIER STOP (HZ/HLM)
 - 19 B PLUS
 - 20 RELAY COIL

* Fig. 3- Relaying Control Circuits - HZ/HLM (Dwg. 1-329C704)

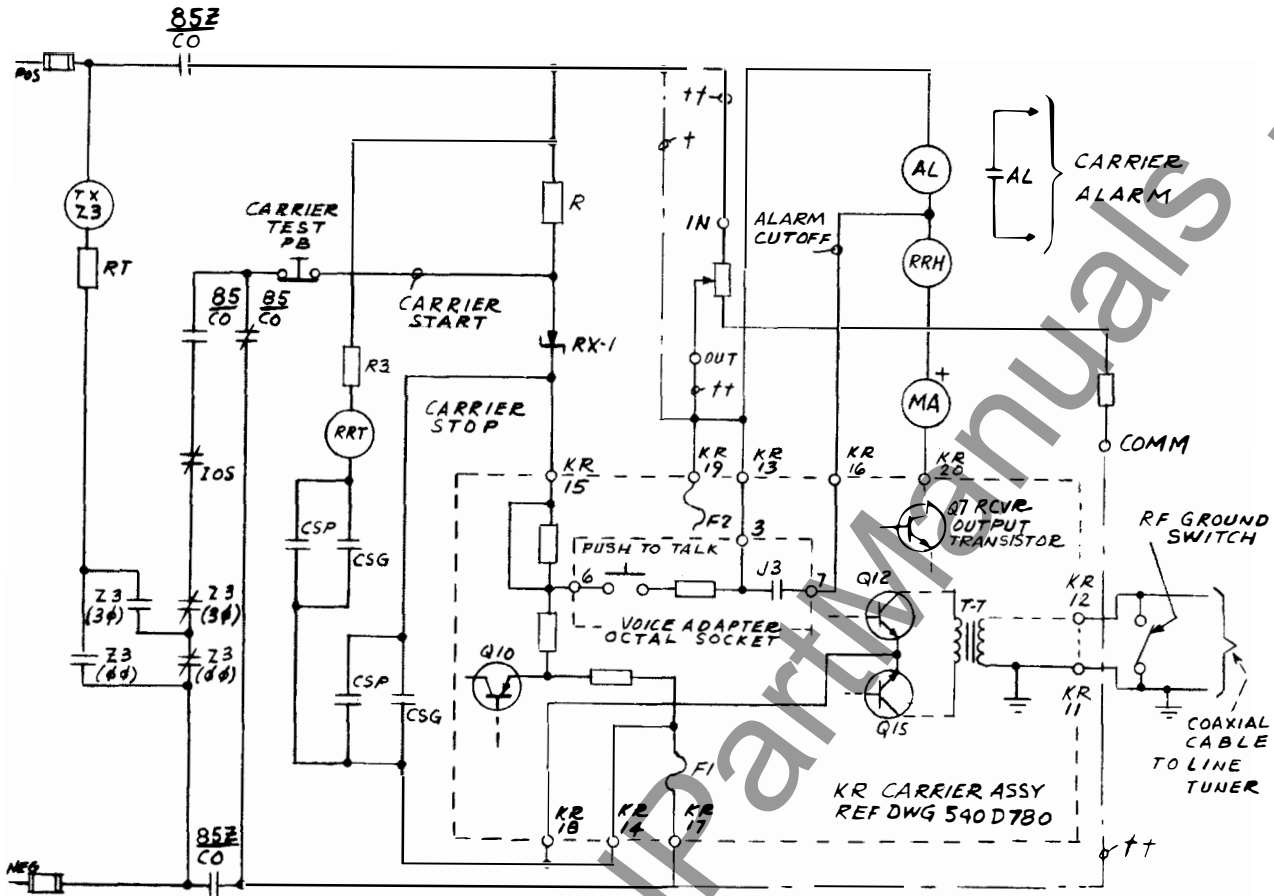

REQUIREMENTS FOR K-DAR RELAYING

SUPPLY VOLTAGE	CARRIER START	CARRIER STOP	R
51 VDC	+ 37V, 7MA	0 VOLTS	2K
129 VDC	+100V 8MA	0 VOLTS	3.75K
258 VDC	+100V 8MA	0 VOLTS	19K

NOTES

**KR RELAYING TRANSMITTER /
RECV. EXTERNAL CONNECTIONS**

TERMINAL CONNECTION

- 11 GROUND
- 12 COAXIAL CABLE
- 13 SUPERVISORY PREFERENCE CONTACT
- 14 CARRIER STOP B- RETURN
- 15 CARRIER START (POSITIVE)
- 16 ALARM CUTOFF FOR COMMUNICATIONS
- 17 B MINUS
- 18 CARRIER STOP (HZ/HZM)
- 19 B PLUS
- 20 RELAY COIL

- + FOR 51 & 129 VDC SUPPLY
- ++ FOR 258VDC SUPPLY USE
330C191401 RESISTOR UNIT
REF DWG 223B497

* Fig. 4-Relaying Control Circuits-K-Dar (Dwg. 3-329C704)

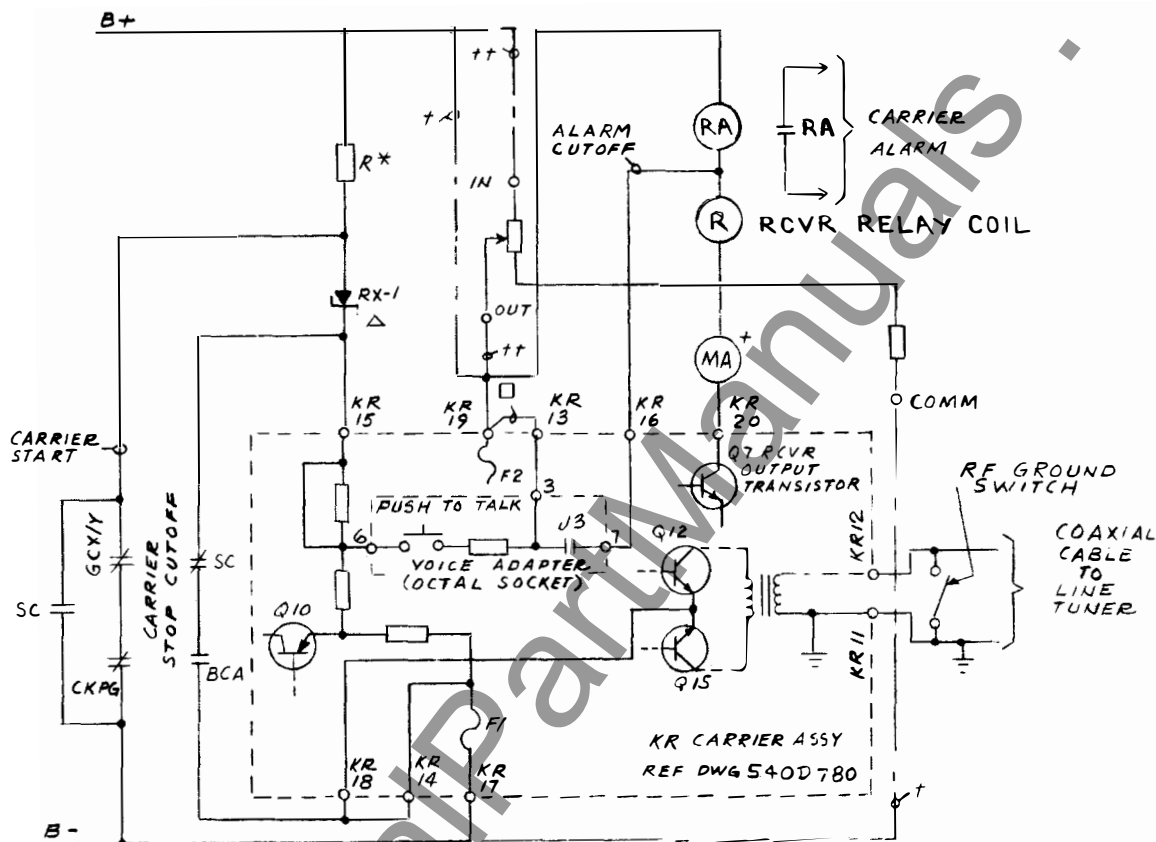

REQUIREMENTS FOR GCY/GCY RELAYING

SUPPLY VOLTAGE	CARRIER START	CARRIER STOP	R
51 VDC	+ 37V, 7MA	0 VOLTS	2K
129 VDC	+ 100V, 8MA	0 VOLTS	3.75K
258 VDC	+ 100V, 8MA	0 VOLTS	19.K

KR RELAYING TRANSMITTER /
RECV. EXTERNAL CONNECTIONS
TERMINAL CONNECTION

- 11. GROUND
- 12. COAXIAL CABLE
- 13. SUPERVISORY PREFERENCE CONTACT
- 14. CARRIER STOP B-RETURN
- 15. CARRIER START (POSITIVE)
- 16. ALARM CUTOFF FOR COMMUNICATIONS
- 17. B MINUS
- 18. CARRIER STOP (HZ/HZM)
- 19. B PLUS
- 20. RELAY COIL

NOTES

- * FOR "R" USE OHMITE VITREOUS ENAMELED DIVIDOHM ADJUSTABLE 4K OR 20K 25W RESISTOR, CONNECT & ADJUST FOR VALUES SHOWN
- Δ TYPE IN 3051
- + FOR 51 & 129 VDC SUPPLY
- ++ FOR 258VDC SUPPLY USE 330C191H01 RESISTOR UNIT REF DWG 223B497
- FOR SUPERVISORY CONTROL PREFERENCE CONTACTS

* Fig. 5. Relaying Control Circuits - GCX/GCY (Dwg. 2-329C704)

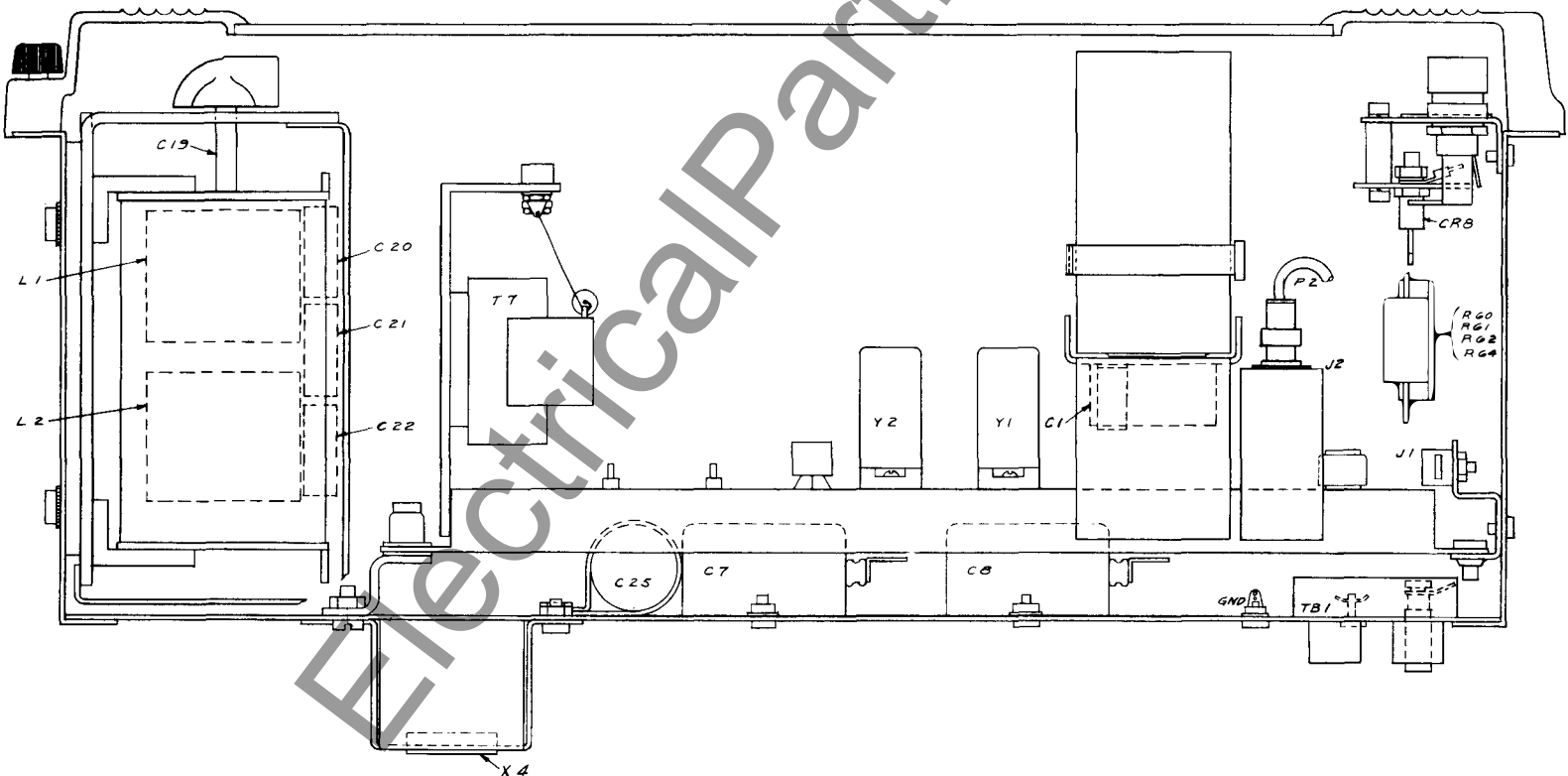
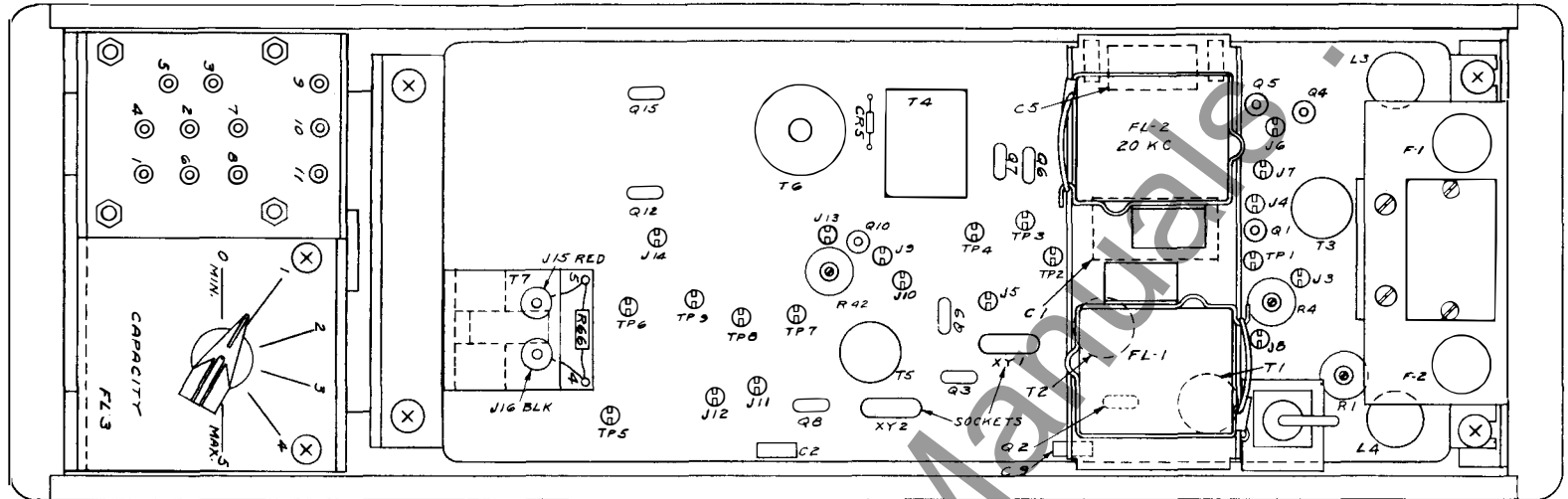
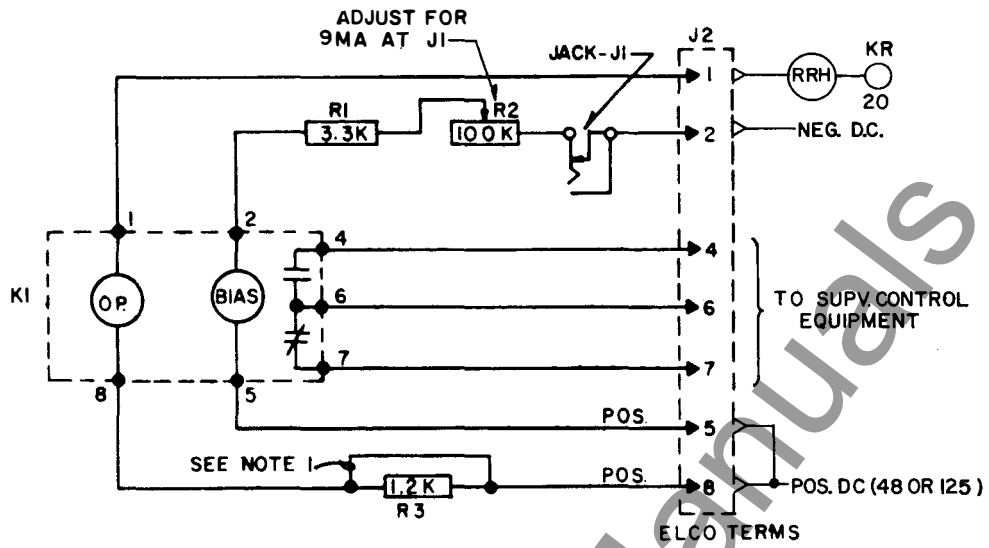

Fig. 6. Component Location (Dwg. 540D781)



- NOTES:
1. REMOVE FOR KR CARRIER PLUS SUPV. CONTROL WITHOUT RELAYING.
 2. POLARITY SHOWN CLOSES CONTACT BETWEEN TERMINALS 4 & 6.

J 2			
1	2	3	4
5	6	7	8

AS VIEWED FROM REAR OF PANEL

629A552

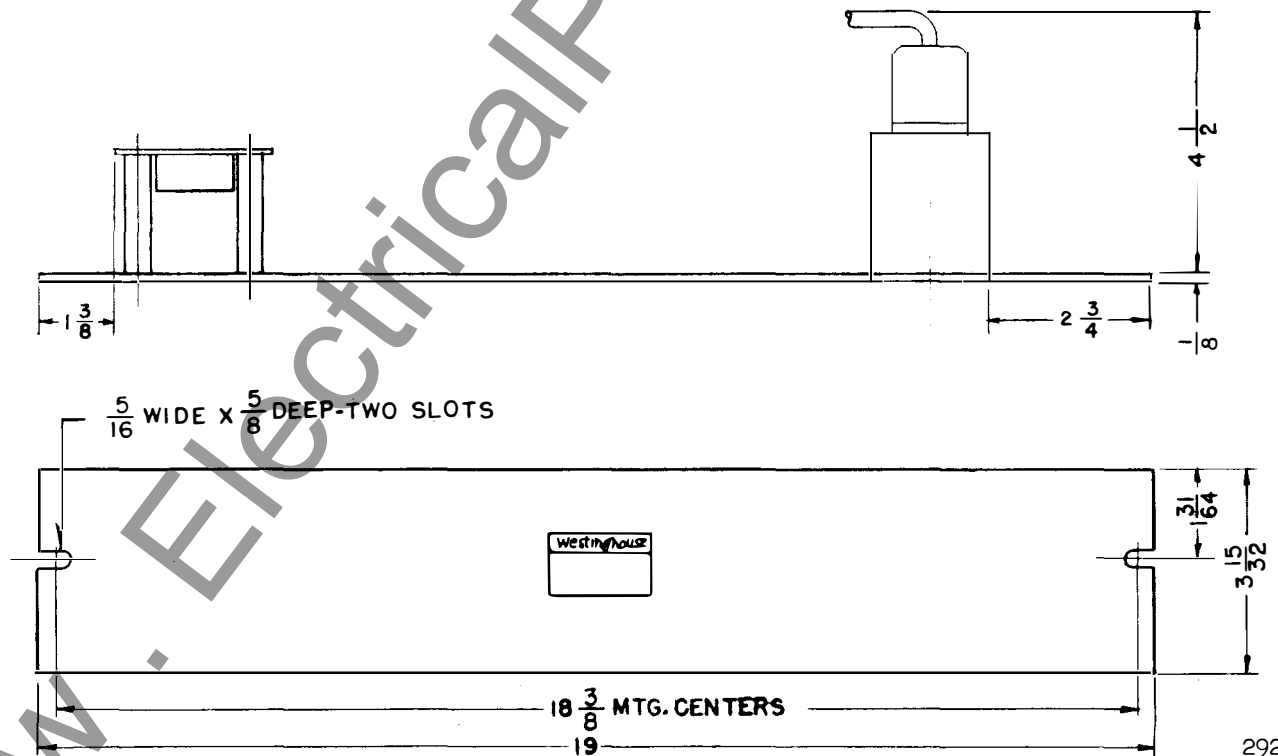

292B991

Fig. 7. Supervisory Control Auxiliary Relay Connections (Dwg. 629A552) and Outline (Dwg. 292B991).

**CONNECTIONS FOR 48-250 VOLT SERVICE AND
SUPERVISORY CONTROL APPLICATION**
(CHANGES FROM JUMPERS SHOWN ON INTERNAL SCHEMATIC, FIG-2)

250-VOLT OPERATION

FOR A 250 VOLT SUPPLY, RESISTOR UNIT 330C191H01 IS USED AS SHOWN ON APPLICATION DRAWING 329C704

FOR HZ/HZM OPERATION, THE JUMPER HAS BEEN REMOVED FROM TP-6 TO TP-7. (NOT REMOVED FOR K-DAR RELAYING).

RESISTOR UNIT SCHEMATIC:

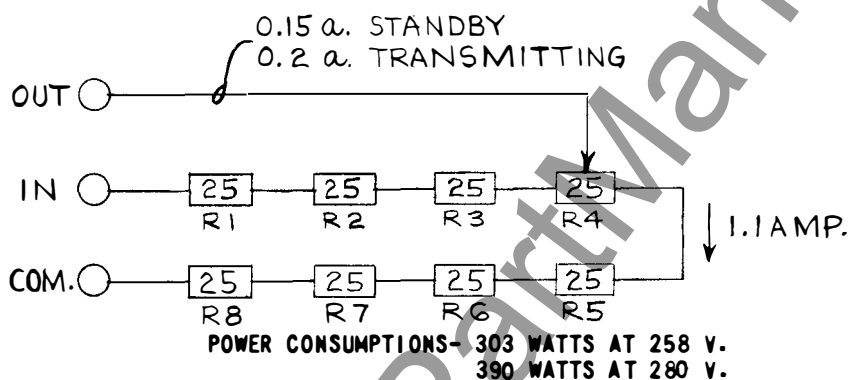

NOTE: KR SUPPLY VOLTAGE WILL BE APPROXIMATELY 144 VOLTS UNDER STANDBY CONDITION WHEN BATTERY VOLTAGE IS 280 VOLTS.

125-VOLT HZ/HZM OPERATION

JUMPER TP-7 AND TP-8 IS REMOVED.

48 VOLT OPERATION

ON PRINTED CIRCUIT BOARD ADDITIONAL JUMPERS ARE CONNECTED AS FOLLOWS:

- BETWEEN TP8 AND TP9
- BETWEEN TP5 AND J12
- BETWEEN TP1 AND TP2
- BETWEEN TP3 AND TP4

IN THE FT CASE, JUMPERS ARE CONNECTED ACROSS R60 AND R64, AND THE CONNECTION BETWEEN R64 AND DIODE CR8 IS REMOVED.

IN ADDITION, FOR 48-VOLT SUPERVISORY CONTROL, R59 IS CONNECTED INTO THE CIRCUIT.

Fig. 8. Connections, 48-250 Volts and Supervisory Control (Dwg. 407C971)

TRANSMITTER OUTPUT FILTER FL-3 CONNECTIONS

<u>LINE</u>	<u>FREQUENCY RANGE</u>	<u>COIL</u>	<u>COIL CONNECTIONS</u>	<u>PARALLEL CAPACITOR CONNECTIONS</u> Δ
1	27.7 KC-30.0 KC	L-1	(1-5) (3-6)	6-8-9-10-11
2	29.8 KC-33.1 KC	L-1	(1-5) (3-6)	6-8-10-11
3	31.8 KC-36.0 KC	L-1	(1-5) (3-6)	6-8-9-11
4	35.4 KC-39.0 KC	L-1	(1-5) (3-6)	6-8-11
5	38.0 KC-41.0 KC	L-1	(1-2) (3-6)	6-8-9-10-11
6	40.3 KC-45.0 KC	L-1	(1-2) (3-6)	6-8-10-11
7	43.0 KC-49.0 KC	L-1	(1-2) (3-6)	6-8-9-11
8	47.7 KC-56.0 KC	L-1	(1-2) (3-6)	6-8-11
9	49.5 KC-58.5 KC	L-1	(1-2) (3-6)	6-8-9-10
10	57.0 KC-72.3 KC	L-1	(1-2) (3-6)	6-8-10
11	67.0 KC-76.0 KC	L-2	(1-4) (6-7)	6-8-9-11
12	75.0 KC-88.0 KC	L-2	(1-4) (6-7)	6-8-11
13	77.5 KC-93.0 KC	L-2	(1-4) (6-7)	6-8-9-10
14	89.3 KC-114.5 KC	L-2	(1-4) (6-7)	6-8-10
15	102.7 KC-147.0 KC	L-2	(1-4) (6-7)	6-8-9
16	136.6 KC-210.0 KC	L-2	(1-4) (6-7)	6-8

Δ CONNECTION FROM 6 TO 8 IS MADE BENEATH TERMINAL PLATE ON ALL SETS AT THE FACTORY.

Fig. 9. Connections - Output Filter (Dwg. 149A420)

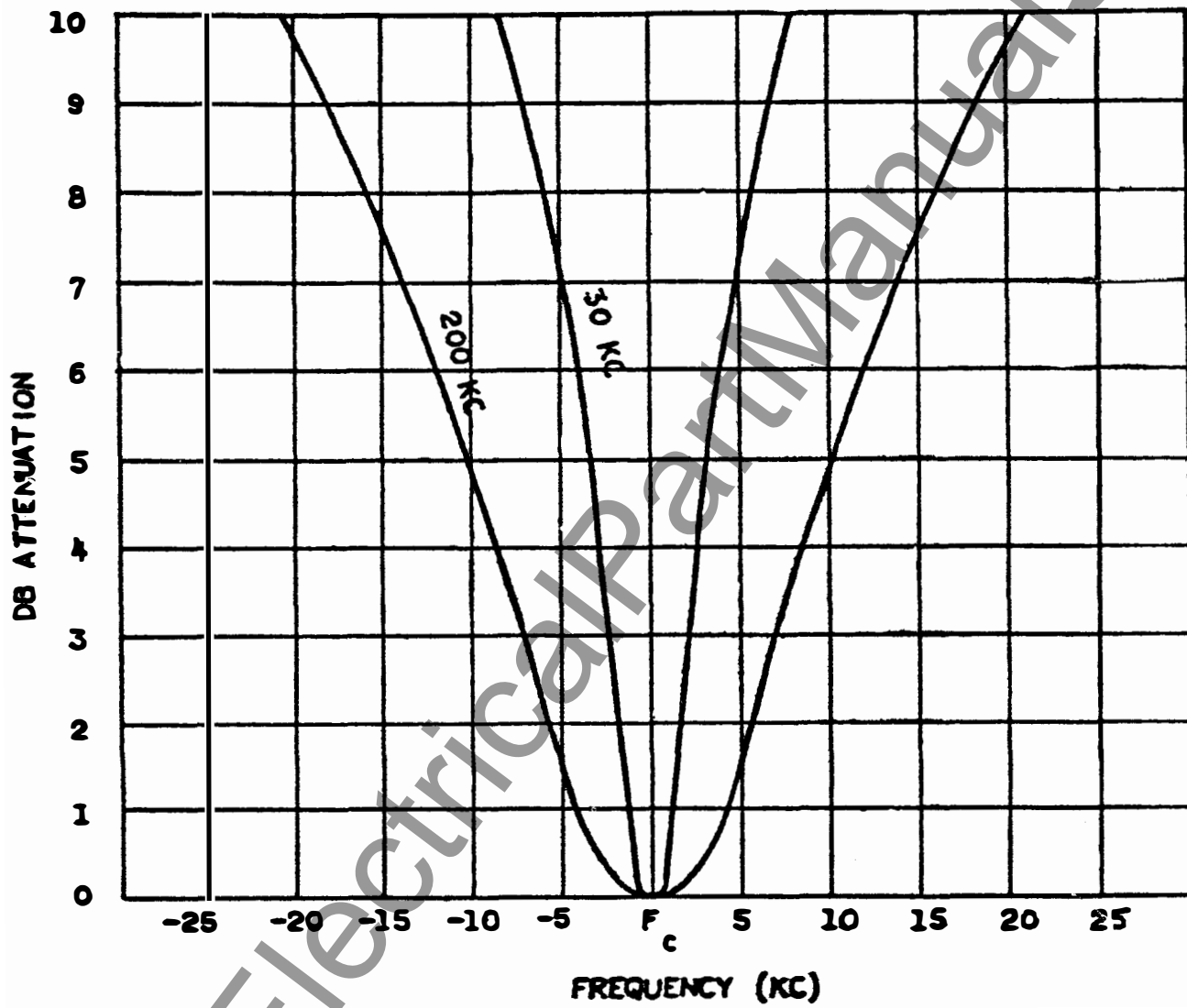

Fig. 10. Transmitter Output Filter Selectivity (Dwg. 377996)

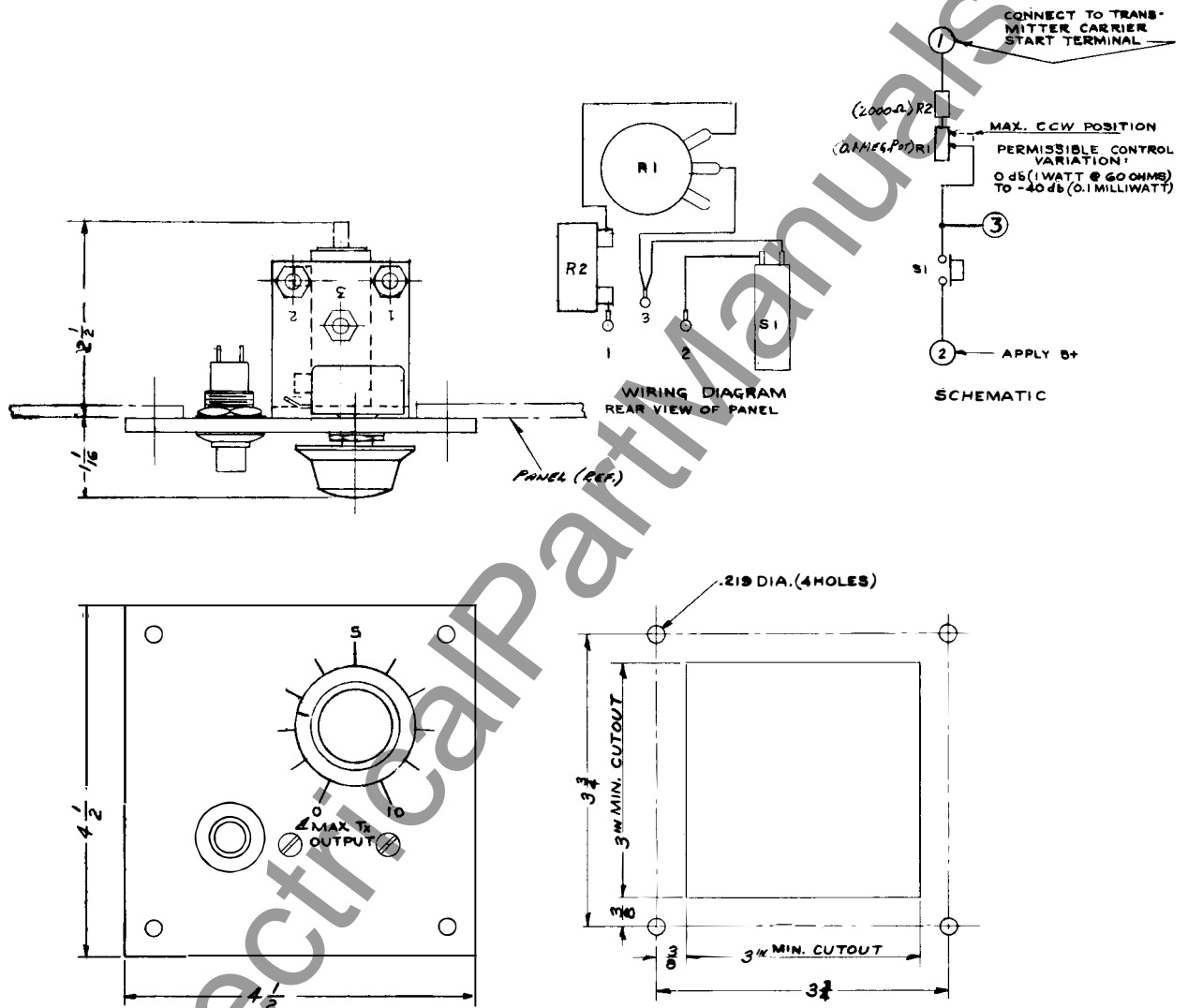

Fig. 11. Reserve Signal Detector Outline (Dwg. 329C703)

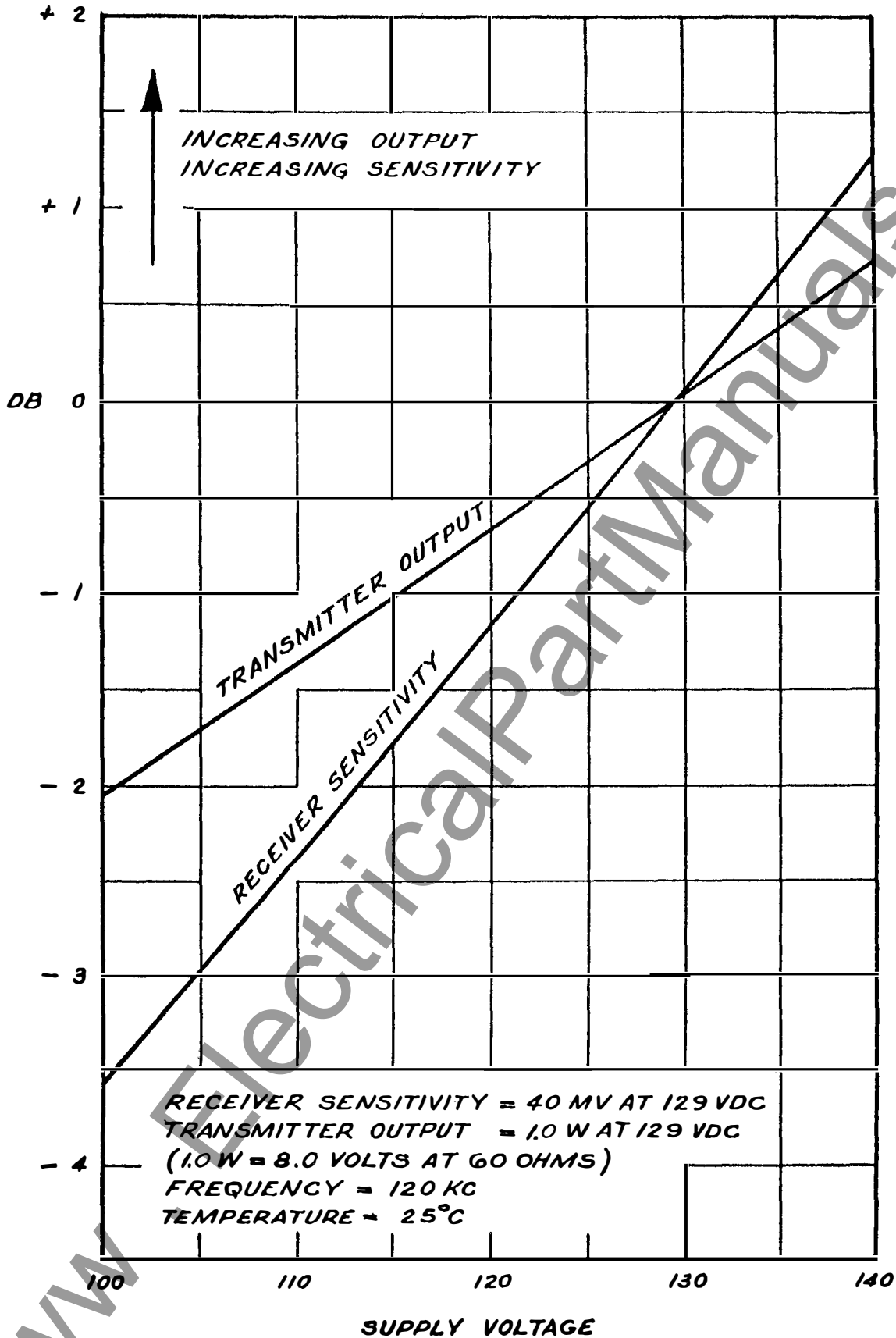

Fig. 12. Transmitter Output and Receiver Sensitivity Variations with Voltage (Dwg. 377999)

TRANSMITTER OUTPUT & RECEIVER SENSITIVITY
VARIATIONS WITH FREQUENCY

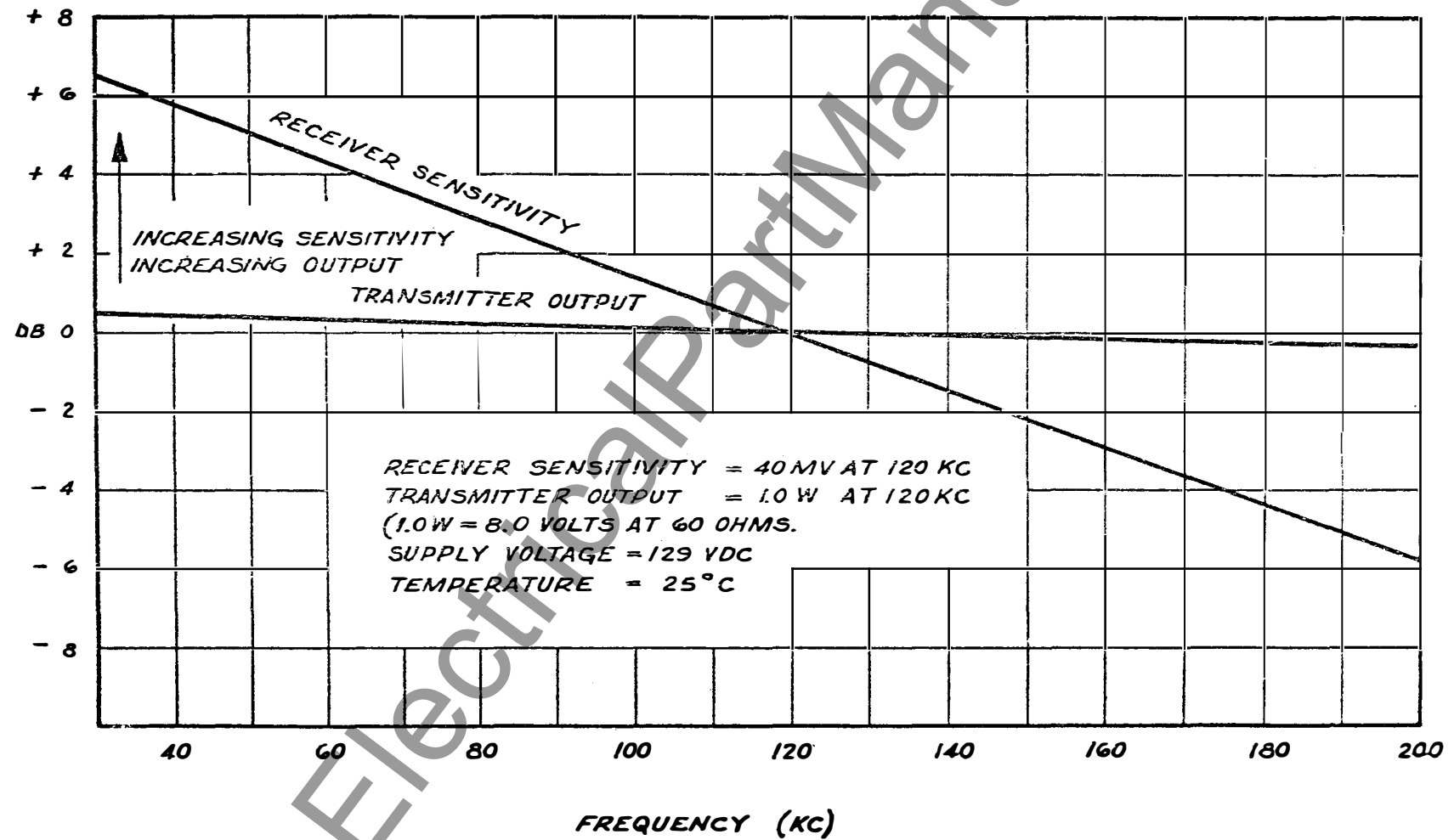

Fig. 13. Transmitter Output and Receiver Sensitivity Variations with Frequency (Dwg. 378000)

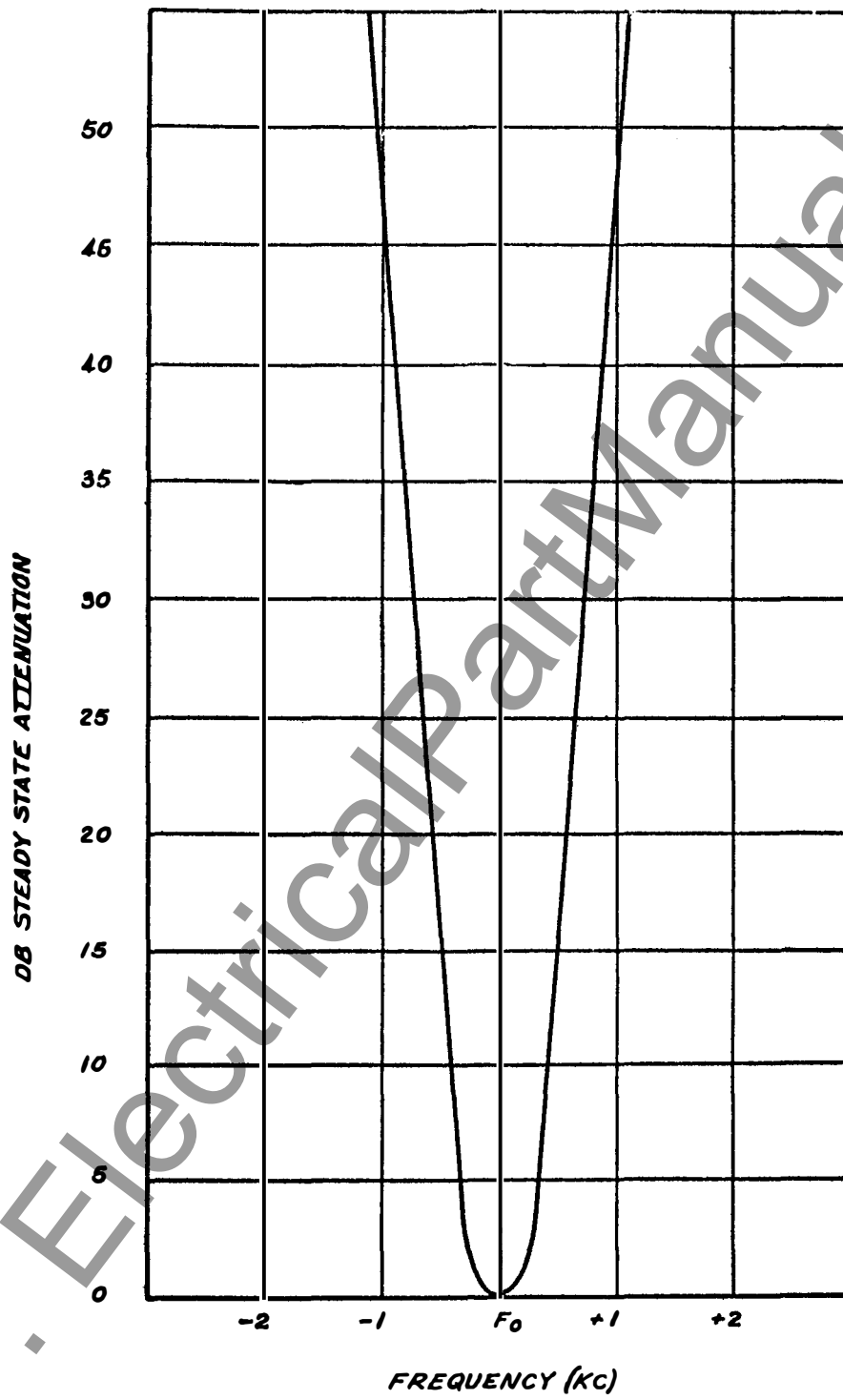
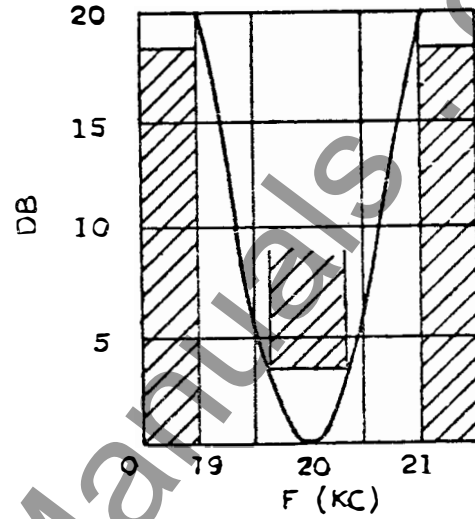
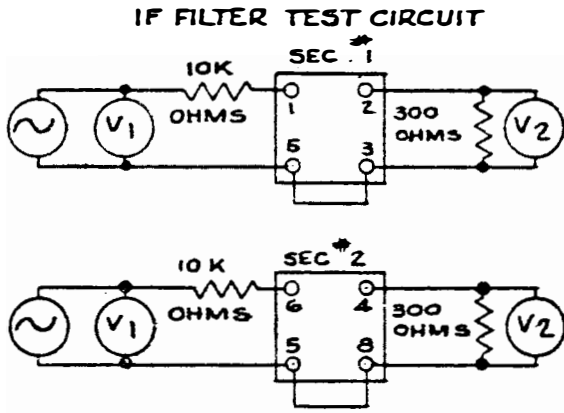
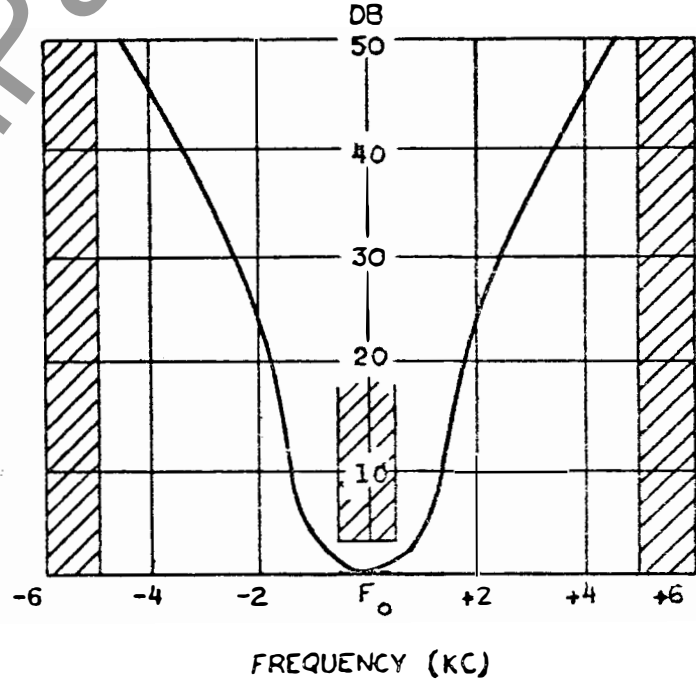
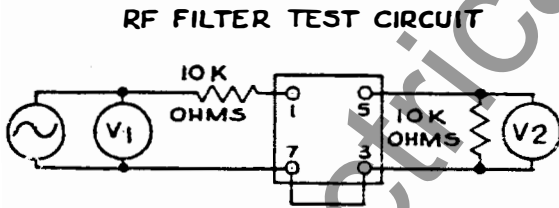

Fig. 14. Receiver Selectivity (Dwg. 377993)



Each section FL-2 requirement with typical selectivity curve
 Insertion loss 26 DB max.
 Including matching resistor.



FL-1 Requirement with typical selectivity curve at 120 KC. Insertion loss 18 DB max. Including matching resistor.

Fig. 15. Receiver Filter Limits (Dwg. 377995)

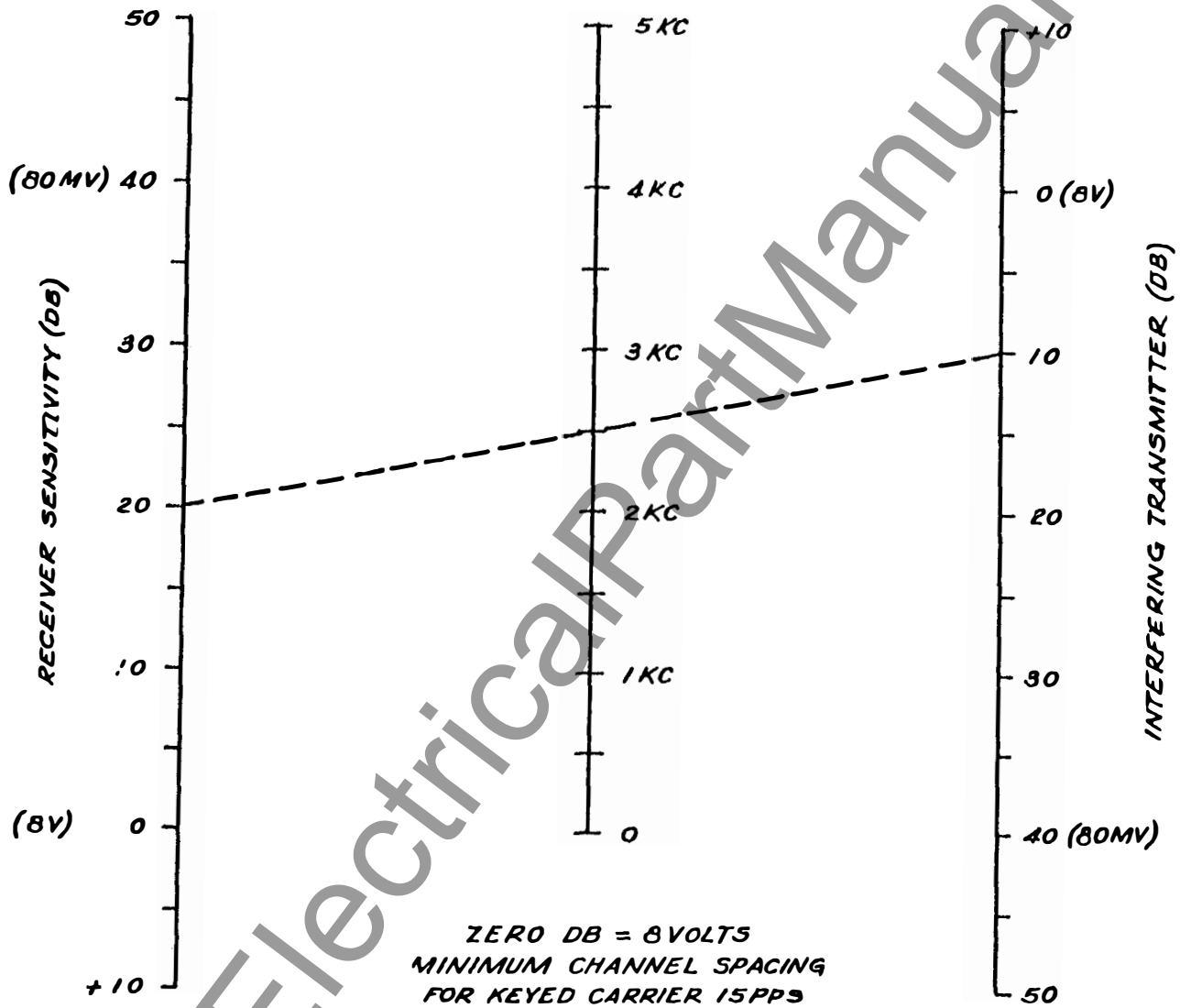
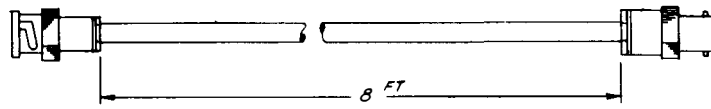
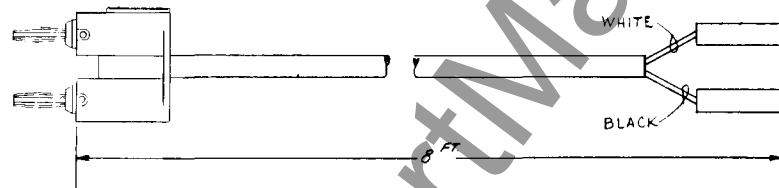

Fig. 16. Minimum Channel Spacing (Dwg. 377998)



Coaxial Lead...756D346 G02



Output Lead...756D346 G03

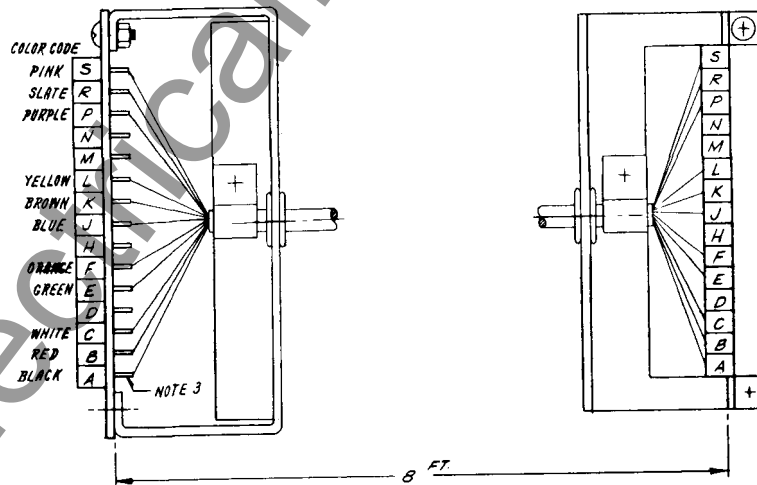

Main Harness...756D346 G04

Fig. 17. Test Harness - (Complete Set)

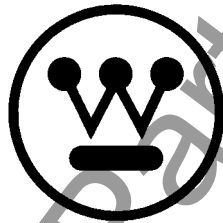

WESTINGHOUSE ELECTRIC CORPORATION
RELAY-INSTRUMENT DIVISION

NEWARK, N. J.

Printed in U.S.A.



INSTALLATION • OPERATION • MAINTENANCE I N S T R U C T I O N S

TYPE KR CARRIER RELAYING TRANSMITTER-RECEIVER

Flexitest Case Mounted —with provision for rear-mounter Voice Adapter Accessories.	Style
KR Reserve Signal Detector	470D167 GO2
250 Volt Resistor Unit	330C191 H01
Test Harness (Complete Set)	756D346 G01
Coaxial Lead	756D346 G02
Output Lead	756D346 G03
Main Harness	756D346 G04

TABLE OF CONTENTS

Introduction	Page 2
Specifications	Page 2
Description	
General	Page 3
Mechanical	Page 3
Electrical	
Transmitter	Page 4
Receiver	Page 4
Transmitter Control Circuits	Page 5
Reserve Signal Detector	Page 5
Communications	Page 5
Relaying Control Circuits	Page 5
Installation	
General	Page 6
Connections	
External	Page 6
Internal	Page 7

Adjustments

Transmitter	Page 7
Receiver	Page 7
Reserve Signal Detector	Page 8
250-Volt Resistor Unit	Page 8
Frequency Change	Page 8
Maintenance	Page 9
Application	Page 13
Electrical Parts List	Page 14

LIST OF TABLES

Table

1 D-C Pin Jack Measurements with Reference to B-	Page 10
2 Transistor DC Measurements with Reference to B-	Page 11
3 D-C Bleeder Measurements with Reference to B-	Page 12
4 Typical RF Signal Measurements for Receiver	Page 12
5 Typical RF Signal Measurements for Transmitter	Page 13

*SUPERSEDES I.L. 41-941.1B
Denotes change from superseded issue.

LIST OF ILLUSTRATIONS

Figure	References
1 Outline – Flexitest Case	540D753
2 Internal Schematic	540D780
3 Relaying Control Circuits (HZ/HZM)	1-329C704
4 Relaying Control Circuits (K-Dar)	3-329C704
5 Relaying Control Circuits (GCX/GCY).....	2-329C704
6 Component Location.....	540D781
7 Supervisory Control Receiver Connection.....	223B498
8 Connections, 48-250 volts and Supervisory Control.....	407C971
9 Transmitter Output Filter Connections	149A420
10 Transmitter Output Filter Selectivity.....	C377996
11 Reserve Signal Detector – Outline and Schematic	329C703
12 Transmitter Output and Receiver Sensitivity Variations with D-C Voltage	C377999
13 Transmitter Output and Receiver Sensitivity Variations with Frequency.	C378000
14 Receiver Selectivity	C377993

15 Receiver Filter Limits	C377995
16 Minimum, Channel Spacing	C377998
17 Test Harness	756D346

CAUTION The voltages encountered in this equipment are dangerous to life. To be safe, disconnect the power source and close the grounding switch when servicing the equipment.

INTRODUCTION

The Type KR Relaying Transmitter-Receiver is designed for Distance Relaying, Telemetry, Supervisory Control and Sleet Detection. Facilities are provided for a plug-in type voice adapter. The basic design is for operation from 125-volt station batteries. However, the apparatus may also be operated from 48-volt or 250-volt station batteries by means of various internal connections. These various connections as well as most of the adjustments are made at the factory, although they can be changed in the field.

Although designed primarily for operation with Westinghouse protective relays, this apparatus may also be coordinated with other types of directional-distance relays and with most other contact keyed devices.

SPECIFICATIONS

Frequency Range.....	30-kc to 200-kc
Channel Attenuation Rating	40-db
Transmitter Power Output	1.0 watt at standard conditions (see Figs. 12 and 13). 0.5 watt with a 48-volt d-c supply.
Transmitter Harmonic Output	At least 46-db below fundamental.
Transmitter Output Impedance.....	Matches one 60-ohm coax. cable. (Suitable for 50-70 ohm cable.)
Transmitter Output Filter Selectivity	See Fig. 10
Transmitter and Receiver Oscillator and Frequency Stability	From -20°C to +50°C with simultaneous voltage variations from 100 to 140 VDC, the frequency remains within 0.01%.

Permissible Battery Voltage Ripple	7-½%
Ambient Temperature Range	-20°C to +50°C.
Non-Operating Temperature Range	-40°C to +70°C
Receiver Sensitivity	0.04 volts at standard conditions (see Figs. 10 and 18).
Receiver Selectivity	See Fig. 14
Receiver Signal-to-Noise Ratio Requirements	12-db
Minimum Channel Spacing	See Fig. 16
Power Input	115-ma at 48 VDC, 200-ma at 125 VDC, 1.28 amperes at 250 VDC.
Carrier On-Off Keying	Requires one pair of contacts capable of keying 8-ma DC at an open circuit voltage of 125 VDC.
Weight (With Flexitest Case)	Approximately 16-lbs.

CAUTION Refer application to Westinghouse when other transmitters are to be connected to the same coax cable as certain conditions may result in damage to the output transistors.

NOTE Standard conditions are taken as 129-volts, 120-kc and 25°C.

or silicon semi-conductor materials. The junction transistor consists of a thin slice of germanium or silicon with three different regions produced by introducing specific amounts of impurities. A thin wire is connected to each region. One outer region is called the emitter, the other the collector, and inserted between them is the base. These correspond roughly to the cathode, plate, and grid of a vacuum tube.

DESCRIPTION

General

This completely transistorized carrier-apparatus is a result of extensive field and laboratory tests. From these tests, it was proven that transistors provide superior reliability over tubes. In addition, the latest printed circuit and filter techniques have improved performance and greatly decreased the size. The expected long life of transistors as compared with vacuum tubes will reduce maintenance costs, and the low power requirements will produce important savings in battery and charger requirements.

Transistors perform the same functions as vacuum tubes. However, tubes operate by the flow of electrons in a vacuum between elements, while transistors depend upon the movement of electrons in a solid. This leads to a more rugged type of construction. Most transistors are made from either germanium

The transistors in this equipment are of the junction type, and both NPN and PNP configurations are used. In the NPN transistor, the majority of the current is carried by electrons. In the PNP transistor there is a deficiency of electrons. These deficiencies are known as "holes". For practical purposes holes may be considered as positively charged "electrons", and these provide most of the current flow in PNP units. In order to obtain maximum efficiency and reliability, both types are used in this equipment.

Silicon transistors are used in the transmitter and receiver output circuit in order to stabilize critical circuit performance at elevated temperatures.

Mechanical

This apparatus is supplied in a Flexitest case and may be either flush or projection mounted in

order to match other switchboard equipment. The outline dimensions and also the drilling plan for flush and projection mounting are shown by Fig. 1. The majority of the parts are mounted on a printed circuit board. This board may be readily removed as follows:

1. Remove the two output plugs from the red and black jacks.
2. Disconnect the receiver input coaxial cable connector.
3. Loosen the two screws at the top of the board.
4. Loosen the two screws at the bottom of the board and pull them out as far as they will extend.
5. Pull board down to disengage the terminals and lift out.

The transmitter output filter may be removed by removing four mounting screws from the bottom of the case and disconnecting the coaxial cable.

Fig. 6. shows the location of major components such as potentiometers, jack, test points, crystals, transistors, etc. External connections and the Schematic Diagram are shown by Fig. 2. The numbered terminals shown as squares apply to the external terminals.

Provisions are made for plugging the Voice Adapter Unit in the rear of the relaying equipment. Octal socket marked X-4 on the rear of the set accommodates the adapter plug. A buckle type strap on each side of the adapter holds the unit in place after it has been plugged in. The normal projection for a rear mounted Voice Adapter is 3-inches beyond that of the relaying equipment. When the KR Relaying Unit is supplied with the adapter, a patch cord is available on separate order. This patch cord plugs into the telephone jacks on the adapter and provides an extension to a conveniently located terminal board.

The panel cutout information necessary for mounting the Sleet Detector is shown by Fig. 11. This unit consists of a potentiometer and pushbutton switch mounted on a small panel, itself suitable for switchboard mounting.

For 250-volt operation, separate auxiliary resistors are required, as shown in Fig. 8.

Electrical

Transmitter

The transmitter is made of four main stages in-

cluding an oscillator, driver, power amplifier, and an output filter. In the oscillator, the crystal is operated as a resonant circuit between the collector of one transistor and the base of the other. The feedback is supplied through a capacitor from the collector of the second transistor to the base of the first transistor. The frequency is independent of voltage or temperature changes of the transistors. Thus the frequency stability is the stability of the crystal.

The input to the driver stage Q-10 is controlled by potentiometer, R-42 which also controls the transmitter power output. In HZM relaying CARRIER STOP provides about +40 volts for blocking. This is applied to Q-10 through T-6. Diode CR-5 prevents damage to the transistor when this positive voltage is applied to the collector. For CARRIER START (when in the blocked position) a small positive voltage is applied to the collector of Q-10 by means of bleeder resistors R-67 and R-68.

The power amplifier consists of two transistors Q-12 and Q-15, which are operated as class B amplifiers in push-pull. Resistors R-52 and R-55 are for stabilization.

The output transformer, T-7, matches coaxial cables of 50 to 70 ohms.

Resistor R-66 tends to keep the source impedance constant to permit proper tuning of the output filter.

The output filter consists of coils L-1 and L-2, capacitors C-19 through C-22. The filter is tunable, and is provided to attenuate harmonics and other spurious outputs. It should be noted that the filter contains no shunt elements, resulting in a reverse impedance free of "across the line" resonances.

Receiver

The receiver is a superheterodyne in order to obtain constant selectivity regardless of the channel frequency. (See Fig. 14.) The major stages include an input filter, attenuator, oscillator, mixer, IF filters, IF amplifiers, detector and a D-C power output stage.

The input filter prevents undesired signals from producing the IF frequency.

The receiver sensitivity is adjusted by means of the continuously variable input control R-1 and by

connecting or disconnecting resistors R-73 and R-74 in the IF stages.

The receiver oscillator (Q-2 and Q-3) is basically the same as the transmitter oscillator. The frequency is 20-kc above the incoming signal frequency.

The receiver channel frequency is determined by the input filter and the oscillator crystal. The frequency may be changed readily since both the filter and the crystal are plug-in components.

Mixing is accomplished by feeding the incoming signal to the emitter and the receiver oscillator signal to the base of the mixer Q-1. Mixer oscillator requirements are met through adjustment of potentiometer R-4. Injection into two separate elements, base and emitter, provides a circuit capable of handling greater signal level variations than one in which injection is made into only a single element such as the base.

This receiver uses an IF frequency of 20-kc. The overall selectivity is determined primarily by the IF filter FL-2. Typical characteristics of this filter are shown in Fig. 15.

The IF amplifier consists of transistors Q-4, Q-5 and Q-6.

The detector is a full wave bridge rectifier. This rectifier in conjunction with the IF amplifier Q-6, provides the necessary power to drive the D-C power output stage Q-7.

The final output stage Q-7 will supply approximately 18 milliamperes to a standard 1700 ohm distance relay RRH coil and its associated 500 ohm alarm coil. It may also be used to drive other relay coils such as is shown by Fig. 7, Supervisory Control Connections.

Transmitter Control Circuits

In the standby condition, although the oscillator is running, the transmitter driver has no emitter bias which results in no output.

Positive voltage applied to terminal 15 supplies this bias through a voltage dividing network, and transmitter output results. The actual configuration of the network is a function of supply voltage and application (Relaying, Telemetry, etc.) and is

discussed in the Adjustments section.

Output may be stopped in several ways. The method used with K-DAR relays is to remove the positive voltage applied to terminal 15. In the case of distance relaying with Westinghouse HZ/HZM relays, application of a positive voltage to terminal 18 will stop the transmitter output. Output may also be stopped by removal of negative battery from terminal 18.

Reserve Signal Detector

The Reserve Signal Detector is shown by Fig. 11. Effectively R-1 is a remote transmitter output control. This control is obtained through varying the driver stage (Q-10) emitter bias, and is effective over a 40-db range of transmitter output. The detector is switched into service by S-1. By adjusting R-1 for a given receiver relay current at the far end of the channel, a relative measure of the channel attenuation may be obtained. This is discussed further in the section on Adjustments.

Communications

The transmitter output is reduced approximately 6-db when the Type KR voice adapter attachment is used. Relaying takes preference, and full output is obtained since full voltage is supplied to terminal 15.

Relaying Control Circuits

Figs. 3, 4 and 5 show simplified diagrams of the relaying control circuits.

1. K-DAR and GCY Relaying (Figs. 4 and 5)

The control of the carrier set is obtained through the CARRIER START and CARRIER STOP contacts. These contacts are shown in their normal standby condition.

The K-DAR or GCY relays operating from the voltage and current on the transmission line, detect and determine the direction of a line fault and thereby control the carrier transmitter and receiver.

The control of the carrier set is such as to start the transmission of carrier when fault power on the transmission line is flowing out of the line section being protected. Conversely, when fault power is flowing into this line section, the control is such as to block the transmitter and keep it from being turned on by secondary functions such as sleet detection

TYPE KR CARRIER SET

and communication, should these functions be in use at the same time. Should carrier be received from the remote station, the hold coil and alarm coil will energize through transistor Q-7 in the receiver.

When carrier start operation occurs, the CARRIER START contact opens applying a positive voltage (see Figs. 4 and 5) to terminal 15 of the carrier set. This puts a potential on the driver stage in the transmitter and also applies proper bias for the power amplifier.

When a carrier stop operation occurs, the CARRIER STOP contact closes, which removes B+ (terminal 15) from the driver and the power amplifier stages in the transmitter. CARRIER STOP, terminal 18, on the carrier set is permanently connected to terminal 14, for K-DAR and GCY relaying.

2. HZM Relaying (Fig. 3)

The control of the carrier set is effected by the CARRIER START and the CARRIER STOP contacts. These contacts are shown in their normal standby condition.

The HZ-HZM relays operating from the voltage and current on the transmission line, detect and determine the direction of a line fault and thereby control the carrier transmitter and receiver.

The control of the carrier set is such as to start the transmission of carrier when fault power on the transmission line is flowing out of the line section being protected. Conversely, when fault power is flowing into this line section, the control is such as to block the transmitter and keep it from being turned on by secondary functions such as sleet detection and communication, should these functions be in use at the same time. Should carrier now be received from the remote station, the hold coil and alarm coil will energize through transistor Q-7 in the receiver.

When carrier start operation occurs, the CARRIER START contact closes applying the full battery supply voltage to terminal 15 of the carrier set. This puts a potential on the driver stage in the transmitter and also applies proper bias for the power amplifier.

When a carrier stop operation occurs, the CARRIER STOP contact opens. This applies a positive voltage (see Fig. 3) to terminal 18 which blocks the driver stage and the power amplifier stage

It is possible under certain conditions that the signals from two transmitters, attempting to block a third receiver, would be of such amplitude, phase and frequency as to cause the RRH coil current to "pulsate". It would then be possible to have a false trip.

In the case of the KR set for relaying 3-terminal lines, the transmitter frequencies (to avoid this possibility of false trip) should be separated by 100 cycles. All receivers and one transmitter would be for the desired center frequency. One of the other transmitters would be 100 cycles above, the other 100 cycles below this center frequency.

INSTALLATION

General

Upon receipt of a unit, whether shipped separately or in an assembly, an immediate inspection should be made. Carefully check for damage or shortages.

For necessary clearances and mounting dimensions, see the following illustrations:

Flexitest Case Mounting..... Fig. 1

Sleet Detector..... Fig. 11

Connections

External

The external connections will vary slightly depending on the application, but in general will be along the lines described as follows: (Refer to the Schematic Diagram, Fig. 2.)

Terminals 11.....	Ground
12.....	Coaxial Cable
13 and 19	Supervisory Preference Contacts
14.....	B- "CARRIER STOP" return
15.....	Battery positive through carrier start contacts
16.....	Battery positive for alarm cutoff (used with com- munication)
17.....	B-
18.....	Carrier Stop for HZM Relaying
19.....	B+
20.....	Relay Coil

CAUTION If the transmitter output load is removed while the transmitter is energized, the transistors in

the power amplifier will be permanently damaged. A dummy load should be connected to the transmitter output if the coax is disconnected and the transmitter is to be energized.

When tuning line coupling equipment, short the coaxial cable to ground before changing taps on the Line Tuner or matching transformer.

Internal

Necessary internal connections are generally made at the factory, to customer order, before apparatus shipment. For reference purposes, these are outlined in the following tabulation. Check the proper bleeder resistors before applying voltage to the equipment.

OPERATION	BLEEDER RESISTORS IN THE CIRCUIT
48-Volt K-DAR, HZM, and GCY Relaying, Telemetering, and Supervisory	R-47 and R-48
125-Volt K-DAR and GCY Relaying	R-45, R-47 and R-48
125-Volt HZM Relaying, Telemetering, and Supervisory	R-41, R-45, R-47 and R-48
250-Volt K-DAR and GCY Relaying	R-45, R-47 and R-48
250-Volt HZM Relaying, Telemetering, and Supervisory	R-39, R-40, R-41, R-45, R-47 and R-48

Various combinations of the inductors and capacitors of the transmitter output filter are required depending on the channel frequency. These are tabulated in Fig. 9.

Adjustments

This apparatus is generally tuned to and tested at the specified channel frequency before shipment. Final adjustments must be made in the field and are described in the following paragraphs. Fig. 6 shows the locations of the various controls.

Transmitter

1. Disconnect the coaxial cable and replace with a 50, 60, or 70 ohm non-inductive resistor depending on the characteristic impedance of the cable used.

2. Fig. 9 shows typical output filter connections for various frequency ranges. In some cases it may be necessary to use either a higher or lower range to tune the filter to resonance.

3. Insert fuses F- 1 and F- 2 to apply power to the apparatus.

4. Connect an A-C Vacuum Tube Voltmeter (VTVM) across the non-inductive load.

5. Unblock the transmitter by closing the CARRIER TEST SWITCH. An alternative is to jumper battery positive to terminal 15.

6. Beginning with the output control R-42 at the maximum counterclockwise position, advance it clockwise until a reading appears on the VTVM. Tune capacitor C-19 for a maximum voltmeter reading.

7. While increasing R-42, tune the output filter for maximum output until the output across the resistor is approximately 8 volts. (See Figs. 12 and 13.) (Approximately 5.5-volts when operating from 51-volt station battery.)

8. Open the test switch and reconnect the coaxial cable.

Receiver

1. The oscillator output control R-4 is pre-set at the factory. However, should any of the oscillator components be changed (including the transistors and the crystal) R-4 will require adjustment.

a. Connect an A-C VTVM to jacks J-3 and J-4.

b. Adjust R-4 for a 0.3 volt reading on the meter.

2. The unit is shipped to have a gain of approxi-

mately 250 millivolts (to produce 10 ma relay current) with input control R-1 in maximum clockwise position. About 10-db additional gain or 80 millivolt sensitivity can be obtained by clipping out resistor R-74, which is connected to the base of Q-4 and the B+ supply for the IF. Approximately 10-db gain or 25 millivolt sensitivity can be obtained by clipping out resistor R-73, which is connected to the base of Q-5 and the B+ supply for the IF. Resistor R-71 has been selected at the factory to provide an overall gain of approximately 25 millivolts.

a. Sensitivity Adjustment for Noise

If the maximum on-frequency noise level is known or can be measured, the receiver can be adjusted for this level. Disconnect the coaxial cable and connect a 60-ohm non-inductive resistor and a VTVM across terminals 11 and 12. Energize the transmitter and output control R-42 for the same output as the maximum noise. Then adjust the receiver input control R-1 to obtain 1-ma output current. If it is impossible to obtain 1-ma output current with control R-1 in the maximum clockwise position, then clip out resistor R-74, which is connected to the base of Q-4. If the gain is still insufficient, clip out resistor R-73, which is connected to the base of Q-5. After completing the adjustment of R-1, restore the transmitter to full output.

b. Sensitivity Adjustment for Remote Signal

When the maximum on-frequency noise is unknown and cannot be conveniently measured, the receiver may be adjusted for the remote signal. First determine the channel attenuation using a Sierra voltmeter or some other convenient method. Disconnect the coaxial cable and connect a 60-ohm non-inductive resistor and a VTVM across terminals 11 and 12. Add 15-db to the channel attenuation. This compensates for average variations such as channel and voltage variations. For example, if the channel attenuation is 5-db, add this to the 15-db making a total of 20-db. Taking this from 8 volts output of the transmitter, the receiver should then be set for a sensitivity of 0.8 volts. To do this, adjust the transmitter output control R-42 for 0.8 volts and then adjust the receiver input control so as to obtain 10-ma output current. If it is impossible to obtain 10-ma output current with control R-1 in the maximum clockwise position, clip out resistor R-74, which is connected to the base of Q-4. If the gain is still insufficient, clip out resistor R-73, which is connected to the base of Q-5. After completing the

adjustment of R-1, restore the transmitter to full output.

It must be kept in mind that the two preceding adjustment procedures are to be used as a guide and will cover the majority of cases; however, cases may arise where conditions change. For example, if the adjustment is made per part a., the noise may increase due to various reasons such as bad insulators, which would require adjusting the receiver to be less sensitive. In the adjustment of part b., the attenuation may increase due to sleet or line switching, which would necessitate increasing the sensitivity of the receiver.

Reserve Signal Detector

Due to different types of operation and supply voltages, it is not practical to have a calibrated dial for this unit. However, calibration may be made at installation by recording transmitter output (either in db or volts) at various knob settings of the detector unit. Then, by adjusting the knob so as to obtain 10 milliamperes relay current at a remote receiver, any increase or decrease in line attenuation may be noted as the difference between the original setting, and the setting required to obtain the given 10 milliamperes.

250-Volt Resistor Unit

With the apparatus energized, adjust R-4 in the 250-volt resistor unit so as to obtain 125-volts at terminals 17 (B-) and 19 (B+) on the relaying set.

Frequency Change

If the frequency is changed in the field, it is necessary to change the input filter FL-1 to the desired channel frequency. This filter is of the plug-in type and may be removed by unsnapping the clamp and pulling the filter out. The transmitter oscillator crystal Y-2 must be changed to the desired channel frequency. The receiver oscillator crystal Y-1 must be changed to the desired channel frequency plus 20 kc. Figure 9 shows the connections for the transmitter output filter. It is necessary to unsolder the existing connections and make the new connections per the chart. After completing the preceding, the tuning procedure as described under Adjustments for transmitter and receiver should then be followed.

Note also that capacitors C2 and C9 in the transmitter and receiver crystal oscillator circuits, respectively, may have to be changed. For fre-

quencies below 110 kc, these capacitors are 270 mmf. each. For frequencies of 110 kc and above, the capacitors are 140 mmf. each.

CAUTION Turn power OFF before removing filters or transistors, as high transient currents may cause permanent damage to the transistors.

MAINTENANCE

Voltage values should be recorded after adjustment in order to establish reference values which will be useful when checking the apparatus. The readings will remain fairly constant over an indefinite period unless a failure occurs. However, if transistors are changed, there may be considerable difference in these readings without the overall performance being affected.

Typical voltage and current values are given as follows. Voltages should be measured with VTVM. Readings may vary as much as $\pm 20\%$.

In the following paragraphs, the transmitter may be unblocked (transmitting) by closing the CARRIER START circuit in the case of HZM relaying, and by opening the CARRIER START circuit in the case of K-DAR and GCY relaying.

1. For D-C pin jack measurements with reference to B-, refer to Table 1.

2. For transistor D-C measurements with reference to B-, refer to Table 2.

3. For D-C bleeder measurements with reference to B-, refer to Table 3.

4. For typical RF signal measurements for receiver, refer to Table 4.

5. For typical RF signal measurements for transmitter, refer to Table 5.

6. Removal of Printed Circuit Board from Flexitest Case.

To remove the printed circuit board, unplug J-15 and J-16 located near the output filter. Loosen the two screws inside the case near the top. Loosen the slotted thumb screws at the lower end of the board and pull these screws out as far as they will extend. Also remove the receiver coaxial cable plug.

Pull board down so as to disengage the terminals, and lift out.

7. Removal of the Output Filter

After the printed board has been removed, remove the screws on the outside of the case at the bottom. Lift out filter and disconnect the coaxial cable.

8. Receiver Filters

Fig. 15 shows typical receiver selectivity curves both RF and IF. If the filters are checked in a test setup, it is necessary to use an accurate signal generator or preferably a signal generator and a frequency counter.

9. Minimum Test Equipment for Installation

a. Milliammeter 0-25 ma DC.

b. 60-ohm 5-watt non-inductive resistor.

c. A-C Vacuum Tube Voltmeter (VTVM). Voltage range 0.003 to 30 volts, frequency range 60 cycles/sec to 230-kc, input impedance 7.5 megohms.

d. D-C Vacuum Tube Voltmeter (VTVM)

Voltage Range: 0.15 to 300 volts

Input Impedance: 7.5 megohms

10. Desirable Test Equipment for Apparatus Maintenance

a. All items listed in Sections 8 and 9.

b. Signal Generator

Output Voltage: up to 8 volts

Frequency Range: 20-kc to 230-kc

c. Oscilloscope

d. Ohmmeter

e. Capacitor checker

f. Test harness (See Fig. 17)

TABLE I

D-C PIN JACK MEASUREMENTS WITH REFERENCE TO B-

Description	Jack	CONDITION A Tx-Blocked †† Rx-No Signal		CONDITION B Tx-Blocked Rx-With Signal		CONDITION C Tx-Unblocked Rx-No Signal	
		129 VDC	51 VDC	129 VDC	51 VDC	129 VDC	51 VDC
RF Input	J-2	0	0	0.3 V	0.3 V		
DC Q-1 Base	J-3	20 V	20 V	20 V	20 V		
DC R _x B+	J-4	20 V	20 V	20 V	20 V		
DC R _x Osc	J-5	7 V	7 V	7 V	7 V		
DC Q-5 Base	J-6	20 V	20 V	20 V	20 V		
B-	J-7						
DC-P1-E	J-8	110 V	32 V	110 V	32 V	110 V	32 V
DC-Q-7 Base	J-9	69 V	0 V	78 V	2.3 V	66 V	0.3 V
DC Q-7 Emit	J-10	70 V	1.0 V	78 V	1.4 V	66 V	1.0 V
DC T _x Osc	J-11	7 V	7 V	7 V	7 V	7 V	7 V
B+	J-12	129 V	51 V	129 V	51 V	129 V	51 V
DC Q-10 Base	J-13					18 V	18 V
DC Q-10 Emit	J-14					18 V	18 V
RF ma out	J-15					130 ma	130 ma
DC ma RRH and ALARM				18 ma	13 ma†		

† With 2000 ohm resistor and Sigma relay.

†† Tx = transmitter, Rx = receiver

TABLE 2

TYPICAL TRANSISTOR DC MEASUREMENTS WITH REFERENCE TO B-

Transistor	Condition A Tx-Blocked Rx-No Signal (Volts)			Condition B Tx-Blocked Rx-With Signal (Volts)			Condition C Tx-Unblocked Rx-No Signal (Volts)		
	E†	B†	C†	E†	B†	C†	E†	B†	C†
Q-1	20.0	20.0	0.38	20.0	20.0	0.4			
Q-2	7	7.2	1.8	7	7.2	1.8			
Q-3	6.2	8.0	2	6.2	8	2.0			
Q-4	20.0	20.0	2.6	20.0	20.0	2.8			
Q-5	20.0	20.0	2.6	20.0	20.0	2.8			
Q-6									
129 VDC	110	110	129	115	114	129			
51 VDC	32	32	51	32	32	51			
Q-7									
129 VDC	70	68	129	78	80	86			
51 VDC	1.0	0	51	1.4	2.2	7.0			
Q-8	6.2	8	2	6.2	8	2	6.2	8	2
Q-9	7	7.2	1.8	7	7.2	1.8	7	7.2	1.8
Q-10††							18	18	0.4
Q-12††							0.27	0.20	50
Q-15††							0.27	0.20	50

† E-Emitter; B-Base; C-Collector.

†† With respect to term F on printed board.

TABLE 3

D-C BLEEDER MEASUREMENTS WITH REFERENCE TO B-

Measurement	129 VDC			51 VDC		
	A†	B†	C†	A†	B†	C†
Junction R-61 and R-62 (J-8)	110V	110V	110V	32V	32V	32V
Junction R-61 and R-27 (J-10)	70V	78V	66V	1.0V	1.4V	1.0V
Junction R-27 and R-60 (P1-P)	69V	77V	65V	0	0	0
Junction CR-8 and R-64 (P1-K)	58V	58V	58V	51V	51V	51V
Junction R-48 and R-47 (J-14)	—	—	18V	—	—	18V
Junction R-45 and R-47 (TP-9)	—	—	45V	—	—	51V
Junction R-45 and R-41 (TP-8)	—	—	98V	—	—	51V

†Conditions: A — Tx-Blocked, Rx-No Signal; B — Tx-Blocked, Rx-With Signal; C — Tx-Unblocked, Rx-No Signal.

TABLE 4
TYPICAL RF SIGNAL MEASUREMENTS FOR RECEIVER
(Made with 0.1 Volt at Terminal 5 of FL1)

Check Point	25 MV Sensitivity (Volts)	80 MV Sensitivity (Volts)	250 MV Sensitivity (Volts)
With Receiver Crystal Out			
FL1-5 to Gnd.	0.1	0.1	0.1
T1-1 to Gnd.	0.1	0.1	0.1
Q1-E to Gnd.	0.05	0.05	0.05
Q1-C to Gnd.	0.07	0.07	0.07
T3-1 to Gnd.	0.07	0.07	0.07
Q4-C to Gnd.	0.07	0.07	0.07
With Receiver Crystal In			
Q4-C to Gnd.	0.5	0.5	0.25
J6 to Gnd.	0.15	0.1	0.08
Q5-C to Gnd.	7.0	1.7	0.8
Q6-B to Gnd.	2.0	0.5	0.4
Q6-C to Gnd.	13.0	10.0	8.0
T4-1 to Gnd.	13.0	10.0	8.0
T4-3 to T4-4	4.5	3.5	2.5
J9 to J10 (DC)	0.74	0.75	0.65

TABLE 5

TYPICAL RF SIGNAL MEASUREMENTS FOR TRANSMITTER	
CHECK POINT	VOLTS
T5-1 to Gnd.	5.5
T5-3 to Gnd.	1.0
J13 to Gnd.	0.085
Q10-C to Gnd.	6.0
T6-2 to Gnd.	6.0
Q12-B to Gnd.	0.8
Q15-B to Gnd.	0.8
Q12-C to Gnd.	38.0
Q15-C to Gnd.	38.0
T7-5 to Gnd.	9.8
Output to Gnd.	8.0

APPLICATION

1. Receiver Selectivity (Fig. 14)

This shows a typical curve of the overall selectivity of the receiver under steady state conditions.

2. Transmitter Output Selectivity (Fig. 10)

Typical curves are shown so that approximate bandwidths for keying purposes can be determined for any carrier frequency between 30-kc and 200-kc.

3. Minimum Channel Spacing (Fig. 16)

This is a graph from which minimum channel spacing can be obtained provided the signal strength of the interfering transmitter and the sensitivity setting of the receiver are known. These can be obtained from calculations or by measurements.

For example, if the interfering transmitter voltage is measured (at the receiver) and found to be 2.5

volts, this would be 10-db down from 8 volts. This point can be located on the right hand column of the graph. Then, if the receiver sensitivity were set to operate on 0.8 volts or 20-db, this point would be located on the left hand column. A line could then be drawn through the two points as shown by the dotted line. The intersection of this line with the center line indicates the minimum channel spacing. In this case if the interfering signal is being keyed on-off, at 15 pps, the minimum spacing would be 2.5-kc.

4. Transmitter Output and Receiver Sensitivity Variations with Voltage (Fig. 12)

These curves show the variation of transmitter output and receiver sensitivity with changes in supply voltage, at 120-kc and 25°C. The increase and decrease in transmitter output above or below 1.0 watts may be obtained in db from the transmitter curve. 1.0 watts is about 8.0 volts with a 60-ohm load.

The increase and decrease in receiver sensitivity above or below 40 millivolts can similarly be

TYPE KR CARRIER SET

obtained in db from the receiver curve. 40 millivolts sensitivity represents the input signal required for proper operation.

5. Transmitter Output and Receiver Sensitivity Variations with Frequency (Fig. 13)

These curves show the variation of transmitter output and receiver sensitivity with variation in frequency, at a supply voltage of 129 VDC, and 25°C. They may be used in the same manner as Fig. 12.

6. Supervisory Control Connections (Fig. 7)

When supervisory control is used with relaying, the supervisory control relay coil is connected in

series with the RRH coil in place of the alarm relay. When supervisory control is used alone, a 1200-ohm resistor R3 is connected in series with the control relay coil by removing the jumper across R3, as shown in Fig. 7. In order to maintain proper mark space ratio, the relay bias current is adjusted for 9 milliamperes as indicated.

The receiver RF filter and the IF filter limits are shown on Fig. 15. Both filters are of the plug-in type and the test circuits with pin connections are shown at the top of each curve. The IF filter is divided into two separate sections. The selectivity shown is for each section, and the pin connections for each section are also shown in the test circuit sketch.

ELECTRICAL PARTS LIST

CIRCUIT SYMBOL	FUNCTION	DESCRIPTION	MFR. CODE	MANUFACTURER'S DESIGNATION
<u>CAPACITORS</u>				
C-1	Rcvr. Bleeder	2.0 μf , $\pm 20\%$, 200 VDC, Paper	1	330C567 H11
†C-2	Rcvr. Osc. Feedback	140/270 μf , $\pm 20\%$, 500 VDC, Mica	1	330C566 H43 or 330C566 H57
C-3	Rcvr. Osc. Bleeder Bypass	0.02 μf , MRC, 600 VDC, Disc	1	330C569 H47
C-5	Q-6 Emitter Bypass	1.0 μf , $\pm 20\%$, 200 VDC Paper	1	330C567 H09
C-6	Rcvr. Rectifier Bypass	Same as C-5		
C-7	B- to B+ Bypass	2 μf , $\pm 10\%$, 600 VDC, Paper	1	14C9400 H 18
C-8	B- to GND	1.0 μf , $\pm 10\%$, 1000 VDC, Paper	1	14C9400 H 17
†C-9	Xmtr. Osc. Feedback	Same as C-2		
C-10	Xmtr. Osc.	Same as C-3		
C-11	Key Filter	0.1 μf , $\pm 20\%$, 200 VDC, Paper	1	330C567 H02
C-12	Q-10 Emitter Bypass	0.25 μf , $\pm 20\%$, 200 VDC, Paper	1	330C567 H05
C-13	Q-10 Bleeder Bypass	Same as C-12		
C-14	PA Base Bypass	Same as C-12		

†Note: 140 μf for osc. freq. 110-kc and above.
270 μf for osc. freq. below 110-kc.

ELECTRICAL PARTS LIST

CIRCUIT SYMBOL	FUNCTION	DESCRIPTION	MFR. CODE	MANUFACTURER'S DESIGNATION
<u>CAPACITORS (Concluded)</u>				
C-18	PA Bleeder	0.5 μf , $\pm 20\%$, Paper	1	330C567 H06
C-19	Output Filter Tuning	500 μf , Variable, Air	1	328C092 H01
C-20	Output Filter	390 μf , $\pm 5\%$, 2500 VDC, Mica	1	330C561 H15
C-21	Output Filter	680 μf , $\pm 5\%$, 2500 VDC, Mica	1	330C561 H21
C-22	Output Filter	1200 μf , $\pm 5\%$, 2500 VDC, Mica	1	330C561 H27
C-24	FL-2 Decoupling	Same as C-12		
C-25	Q-7 Emitter	12 mfd, $\pm 20\%$, 200 VDC	1	187A177 H01
<u>CRYSTAL DIODES</u>				
CR-1	Bridge Rectifier	General Purpose, 1N63	1	584C433 H02
CR-2	Bridge Rectifier	Same as CR-1		
CR-3	Bridge Rectifier	Same as CR-1		
CR-4	Bridge Rectifier	Same as CR-1		
CR-5	Q-10 Collector	Same as CR-1		
CR-6	Q-7 Collector	Same as CR-1		
CR-7	Voltage Regulator	Type 1N768,	1	584C434 H02
CR-8	Voltage Regulator	Type 1N1369	1	584C434 H05
CR-9	Q-7 Collector	Type 1N1789	1	584C434 H08

ELECTRICAL PARTS LIST

CIRCUIT SYMBOL	FUNCTION	DESCRIPTION	MFR. CODE	MANUFACTURER'S DESIGNATION
<u>FUSE HOLDERS</u>				
FH-1	B-	For Type 3AGC Fuses	1	584C271 H02
FH-2	B+	Same as FH-1		
<u>FUSES</u>				
F-1	B-	3AGC 3/4 amp.	1	S#330C691 H12
F-2	B+	Same as F-1		
<u>FILTERS</u>				
FL-1	Rcvr. RF Bandpass Freq. to be specified by customer	30-kc to 60-kc	1	
		60-kc to 110-kc	1	
		110-kc to 200-kc	1	
FL-2	Rcvr. IF Bandpass	20-kc Fixed Freq.	1	
<u>CONNECTORS</u>				
J-1	Printed Circuit	Printed Circuit Female Plug	1	54-B-7125 H03
J-2	RF Input	UG-185-U	1	584C292 H07
J-3	Rcvr. Osc. Output	Terminal Studs	1	330C592 H01
J-4	Rcvr. Mixer-Amp Supply	Same as J-3		
J-5	Rcvr. Osc. Supply	Same as J-3		
J-6	Q-5 Base	Same as J-3		
J-7	B-	Same as J-3		
J-8	Q-6 Supply	Same as J-3		

ELECTRICAL PARTS LIST

CIRCUIT SYMBOL	FUNCTION	DESCRIPTION	MFR. CODE	MANUFACTURER'S DESIGNATION
		<u>CONNECTORS (Concluded)</u>		
J-9	Q-7 Base	Same as J-3		
J-10	Q-7 Emitter	Same as J-3		
J-11	Xmtr. Osc. Supply	Same as J-3		
J-12	B+	Same as J-3		
J-13	Xmtr. Osc. Output	Same as J-3		
J-14	Q-10 Supply	Same as J-3		
J-15	Output Filter	Banana Tip Red	1	328C093 H01
J-16	Output Filter GND	Banana Tip Black	1	328C093 H02
P-1	Printed Circuit	Printed Circuit Male Plug	1	54-B-7126 H03
		<u>INDUCTORS</u>		
L-1	Core and Coil Assembly	11 MH Total - 6 MH Tap (Part of FL-3)	1	329C450
L-2	Core and Coil Assembly	2.5 MH (Part of FL-3)	1	329C449
L-3	RF Choke	1.0 MH, 300 ma	2	R-300
L-4	RF Choke	Same as L-3		
		<u>TRANSISTORS</u>		
Q-1	Rcvr. Mixer	Type 2N43 or Type 2N525	1	330C587 H07 (2N525) 330C587 H02 (2N43)
Q-2	Rcvr. Osc.	Type 2N414	1	330C587 H09

ELECTRICAL PARTS LIST

CIRCUIT SYMBOL	FUNCTION	DESCRIPTION	MFR. CODE	MANUFACTURER'S DESIGNATION
		<u>TRANSISTORS (Concluded)</u>		
Q-3	Rcvr. Osc.	Same as Q-2		
Q-4	Rcvr. IF	Same as Q-1		
Q-5	Rcvr. IF	Same as Q-1		
Q-6	Rcvr. IF	Type 2N332,	1	330C587 H06
Q-7	Rcvr. Output	Type 2N1156	1	330C587 H01
Q-8	Xmtr. Osc.	Same as Q-2		
Q-9	Xmtr. Osc.	Same as Q-2		
Q-10	Xmtr. Amp.	Same as Q-1		
Q-12	Xmtr. PA	Type 2N498	1	330C587 H12
Q-15	Xmtr. PA	Same as Q-12		
		<u>RESISTORS</u>		
R-1	Rec. Input	25 K, $\pm 20\%$, 1/4 W, Pot.	1	584C276 H23
R-2	Filter Matching	10 K, $\pm 10\%$, 1/2 W	1	330C595 H37
R-3	Filter Load	Same as R-2		
R-4	Rcvr. Osc.	1 K, $\pm 20\%$, 1/4 W, Pot.	1	584C276 H19
R-5	Rcvr. Voltage Divider	6.2 K, $\pm 5\%$, 1 W	1	330C666 H68
R-6	Q-2 Collector	1.2 K, $\pm 5\%$, 1/2 W	1	330C664 H51
R-8	Rcvr. Voltage Divider	30 K, $\pm 5\%$, 2 W	1	330C668 H84
R-9	Rcvr. Voltage Divider	Same as R-8		

ELECTRICAL PARTS LIST

CIRCUIT SYMBOL	FUNCTION	DESCRIPTION	MFR. CODE	MANUFACTURER'S DESIGNATION
		<u>RESISTORS (Continued)</u>		
R-10	Q-2 Base	Same as R-2		
R-11	Q-2 Base	100 K, $\pm 5\%$, 1/2 W	1	330C665 H05
R-12	Q-3 Collector	Same as R-6		
R-13	Q-3 Emitter	390 Ohms, $\pm 5\%$, 1/2 W	1	330C664 H39
R-14	Q-3 Base	Same as R-2		
R-15	Q-3 Base	Same as R-11		
R-16	Rcvr. Osc. Bleeder	2.2 K, $\pm 10\%$, 1/2 W	1	330C595 H41
R-17	Rcvr. Osc. Bleeder	18 K, $\pm 10\%$, 2 W	1	330C597 H40
R-18	Rcvr. Osc.	9.1 K, $\pm 5\%$, 1/2 W	1	330C664 H72
R-19	Q-4 Bias	100 Ohms, $\pm 5\%$, 1/2 W	1	330C664 H25
R-20	Q-4 Bias	Same as R-2		
R-21	Q-5 Bias	150 Ohms, $\pm 5\%$, 1/2W	1	330C664 H29
R-22	Q-5 Bias	Same as R-2		
R-23	Q-6 Bias	330 Ohms, $\pm 5\%$, 1/2 W	1	330C664 H37
R-24	Q-6 Bias	Same as R-2		
R-25	Q-6 Emitter	Same as R-19		
R-26	Q-7 Base	Same as R-6		
R-27	Q-7 Bias	20 Ohms, $\pm 5\%$, 1/2 W	1	330C664 H08
R-28	Xmtr. Osc. Bleeder	Same as R-18		
R-29	Xmtr. Osc. Bleeder	Same as R-17		
R-30	Xmtr. Osc. Bleeder	Same as R-16		

ELECTRICAL PARTS LIST

CIRCUIT SYMBOL	FUNCTION	DESCRIPTION	MFR. CODE	MANUFACTURER'S DESIGNATION
<u>RESISTORS (Continued)</u>				
R-31	Q-8 Base	Same as R-11		
R-32	Q-8 Base	Same as R-2		
R-33	Q-8 Emitter	Same as R-13		
R-34	Q-8 Collector	Same as R-6		
R-35	Q-9 Base	Same as R-11		
R-36	Q-9 Base	Same as R-2		
R-37	Q-9 Collector	Same as R-6		
R-38	Key Filter	Same as R-23		
R-39	Buffer Voltage Divider	36 K, $\pm 5\%$, 2 W	1	330C668 H86
R-40	Buffer Voltage Divider	Same as R-39		
R-41	Buffer Voltage Divider	Same as R-2		
R-42	Xmtr. Osc. Output	Same as R-4		
R-43	Q-10 Bias	Same as R-23		
R-44	Q-10 Bias	33 K, $\pm 5\%$, 1/2 W	1	330C664 H85
R-45	Buffer Voltage Divider	15 K, $\pm 10\%$, 1 W	1	330C596 H39
R-47	Buffer Voltage Divider	6.8 K, $\pm 5\%$, 1/2 W	1	330C664 H69
R-48	Buffer Voltage Divider	15 K, $\pm 5\%$, 1/2 W		330C664 H77
R-49	PA Bias	27 K, $\pm 5\%$, 2 W	1	330C668 H83

ELECTRICAL PARTS LIST

CIRCUIT SYMBOL	FUNCTION	DESCRIPTION	MFR. CODE	MANUFACTURER'S DESIGNATION
		<u>RESISTORS (Concluded)</u>		
R-50	Xmtr. PA	Same as R-19		
R-52	Q-12 Emitter	10 Ohms, $\pm 5\%$, 1/2 W	1	330C664 H01
R-55	Q-15 Emitter	Same as R-52		
R-59	Xmtr. Bleeder	47 Ohms, $\pm 10\%$, 1/2 W	1	330C595 H09
R-60	Recvr. Bleeder	1 K, $\pm 5\%$, 25 W	1	584C416 H57
R-61	Recvr. Bleeder	600 Ohms, $\pm 5\%$, 25 W	1	584C416 H47
R-62	Recvr. Bleeder	350 Ohms, $\pm 5\%$, 25 W	1	584C416 H52
R-64	Xmtr. Bleeder	1200 Ohms, $\pm 5\%$, 25 W	1	584C416 H64
R-66	T-7 Load	560 Ohms, $\pm 5\%$, 2 W	1	330C668 H43
R-67	Xmtr. Blocking	10 Ohms, $\pm 5\%$, 2 W	1	330C668 H01
R-68	Xmtr. Blocking	10 K, $\pm 10\%$, 10 W	1	330C577 H01
R-69	Q-10 Emitter	Same as R-19		
R-70	FL2 Decoupling	470 Ohms, $\pm 10\%$, 1/2 W	1	330C595 H21
R-71	Q-4 Emitter	150 Ohms, $\pm 10\%$, 1/2 W	1	330C595 H15
R-72	Q-5 Emitter	68 Ohms, $\pm 10\%$, 1/2 W	1	330C595 H11
R-73	Q-5 Base	180 Ohms, $\pm 10\%$, 1/2 W	1	330C595 H16
R-74	Q-4 Base	2.7 K, $\pm 5\%$, 1/2 W	1	330C664 H59
R-75	Q-4 Collector	22 K, $\pm 10\%$, 1/2 W	1	330C595 H41
R-76	Q-5 Collector	Same as R-75		

ELECTRICAL PARTS LIST

CIRCUIT SYMBOL	FUNCTION	DESCRIPTION	MFR. CODE	MANUFACTURER'S DESIGNATION
<u>TRANSFORMERS</u>				
T-1	Rcvr. Input	Impedance Ratio 10 K; 10K	1	S#1962798, L-633005
T-2	Rcvr. Osc.	Impedance Ratio 10 K: 400 ohms	1	S#1962797, L-633003
T-3	Rcvr. Mixer	Impedance Ratio 25 K: 300 ohms	1	S#1962697, L-592171
T-4	IF Output	Impedance Ratio 4 K: 500 ohms	1	S#1962693, L-592289
T-5	Xmtr. Osc.	Same as T-2		
T-6	Xmtr. Buffer	Impedance Ratio 10 K: 400 ohms CT	1	S#1962698, L-592170
T-7	Xmtr. Output	Impedance Ratio 1930: 60	1	S#1962694, L-633000
<u>TEST POINTS</u>				
TP-1	R-5	Terminal studs	1	330C592 H02
TP-2	R-8	Same as TP-1		
TP-3	R-17	Same as TP-1		
TP-4	R-18	Same as TP-1		
TP-5	R-28	Same as TP-1		
TP-6	R-39 & R-40	Same as TP-1		
TP-7	R-41	Same as TP-1		
TP-8	R-45	Same as TP-1		
TP-9	R-47	Same as TP-1		

ELECTRICAL PARTS LIST

CIRCUIT SYMBOL	FUNCTION	DESCRIPTION	MFR. CODE	MANUFACTURER'S DESIGNATION
<u>SOCKETS</u>				
X-1	FL-1	Octal	1	330C689 H01
X-2	FL-2	Same as X-1		
X-4	Rear Mounted Voice Adaptor	Same as X-1		
XY-1	Rec. Y-1	Crystal	1	584C606 H01
XY-2	Xmtr. Y-2	Same as XY-1		
<u>CRYSTALS</u>				
Y-1	Rcvr. Osc.	Specify Channel Freq. Plus 20-kc	1	328C083
Y-2	Xmtr. Osc.	Specify Freq. Same as Channel Frequency	1	328C083
<u>RESERVE SIGNAL DETECTOR</u> (S#470D167G02)				
R-1	Resistor, Level Control	100 K, 2 W, Pot.	1	51-D-1976 H17 (S#1475074)
R-2	Resistor, Limiting	2000 ohms, 2" tube.	1	1267296
S-1	Test Switch	SPST Normally Open	1	327C854 H01

LIST OF MANUFACTURERS

1. Westinghouse Electric Corporation
2. National Co., Inc., Malden, Mass.

TYPE KR CARRIER SET

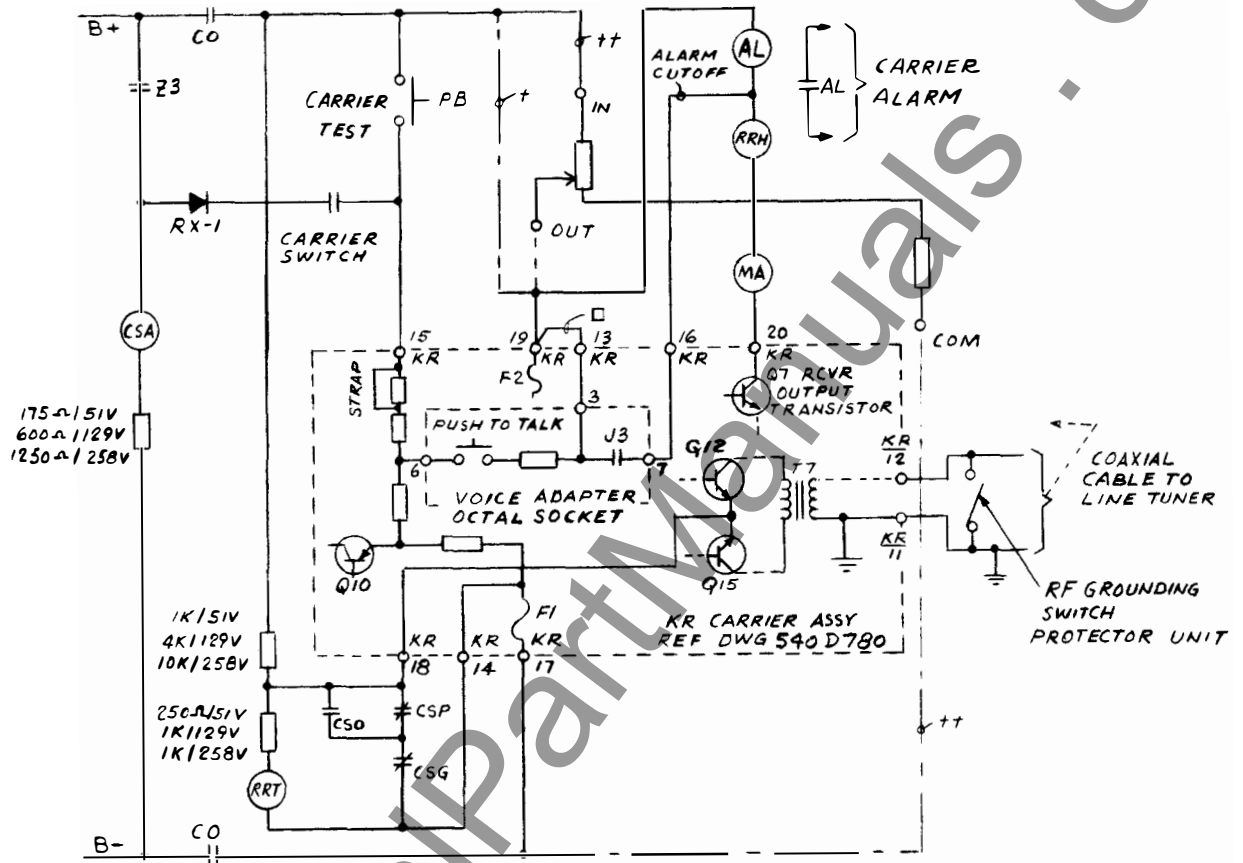

REQUIREMENTS FOR HZ/HZM RELAYING

SUPPLY VOLTAGE	CARRIER START	CARRIER STOP	STRAP
5VDC	+5V, 7MA	+28V	IN
129VDC	+129V, 8MA	+40V	IN
258VDC	+258V, 8MA	+40V	OUT

KR RELAYING TRANSMITTER / RELY. EXTERNAL CONNECTIONS

TERMINAL CONNECTION

- 11. GROUND
- 12. COAXIAL CABLE
- 13. SUPERVISORY PREFERENCE CONTACT
- 14. CARRIER STOP B- RETURN
- 15. CARRIER START (POSITIVE)
- 16. ALARM CUTOFF FOR COMMUNICATIONS
- 17. B MINUS
- 18. CARRIER STOP (HZ/HZM)
- 19. B PLUS
- 20. RELAY COIL

NOTES

- + FOR 51 & 129 VDC SUPPLY.
- ++ FOR 258 VDC SUPPLY USE 330C191H01 RESISTOR UNIT REF DWG 223B497.
- FOR SUPERVISORY CONTROL PREFERENCE CONTACTS.

* Fig. 3- Relaying Control Circuits - HZ/HZM (Dwg. 1-329C704)

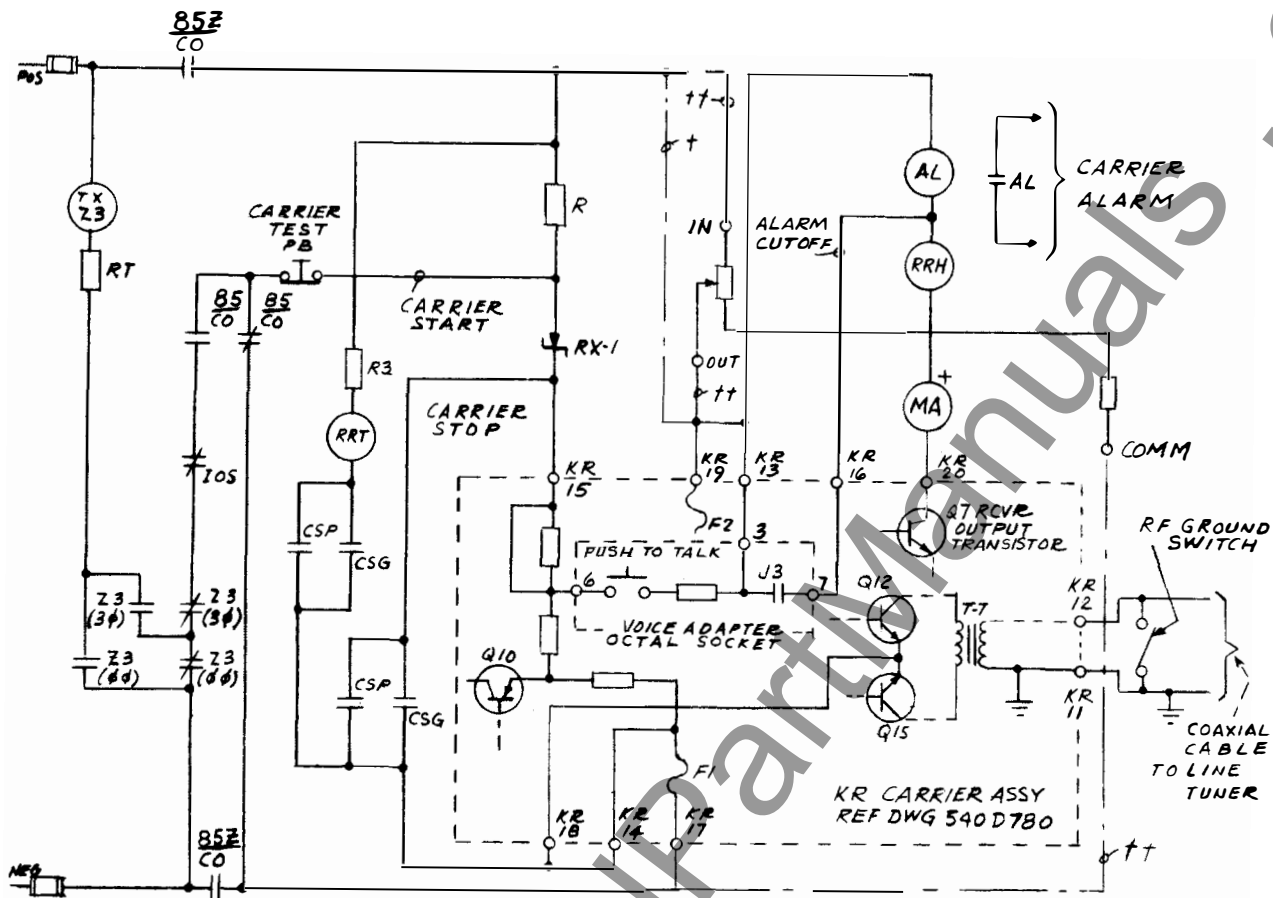

REQUIREMENTS FOR K-DAR RELAYING

SUPPLY VOLTAGE	CARRIER START	CARRIER STOP	R
51 VDC	+ 37V, 7MA	0 VOLTS	2K
129 VDC	+100V 8MA	0 VOLTS	3.75K
258 VDC	+100V 8MA	0 VOLTS	19K

NOTES

KR RELAYING TRANSMITTER /
RECV. EXTERNAL CONNECTIONS

TERMINAL CONNECTION

- 11 GROUND
- 12 COAXIAL CABLE
- 13 SUPERVISORY PREFERENCE CONTACT
- 14 CARRIER STOP B- RETURN
- 15 CARRIER START (POSITIVE)
- 16 ALARM CUTOFF FOR COMMUNICATIONS
- 17 B MINUS
- 18 CARRIER STOP (HZ/HZM)
- 19 B PLUS
- 20 RELAY COIL

- † FOR 51 & 129 VDC SUPPLY
- †† FOR 258VDC SUPPLY USE
330C191H01 RESISTOR UNIT
REF DWG 223B497

* Fig. 4-Relaying Control Circuits-K-Dar (Dwg. 3-329C704)

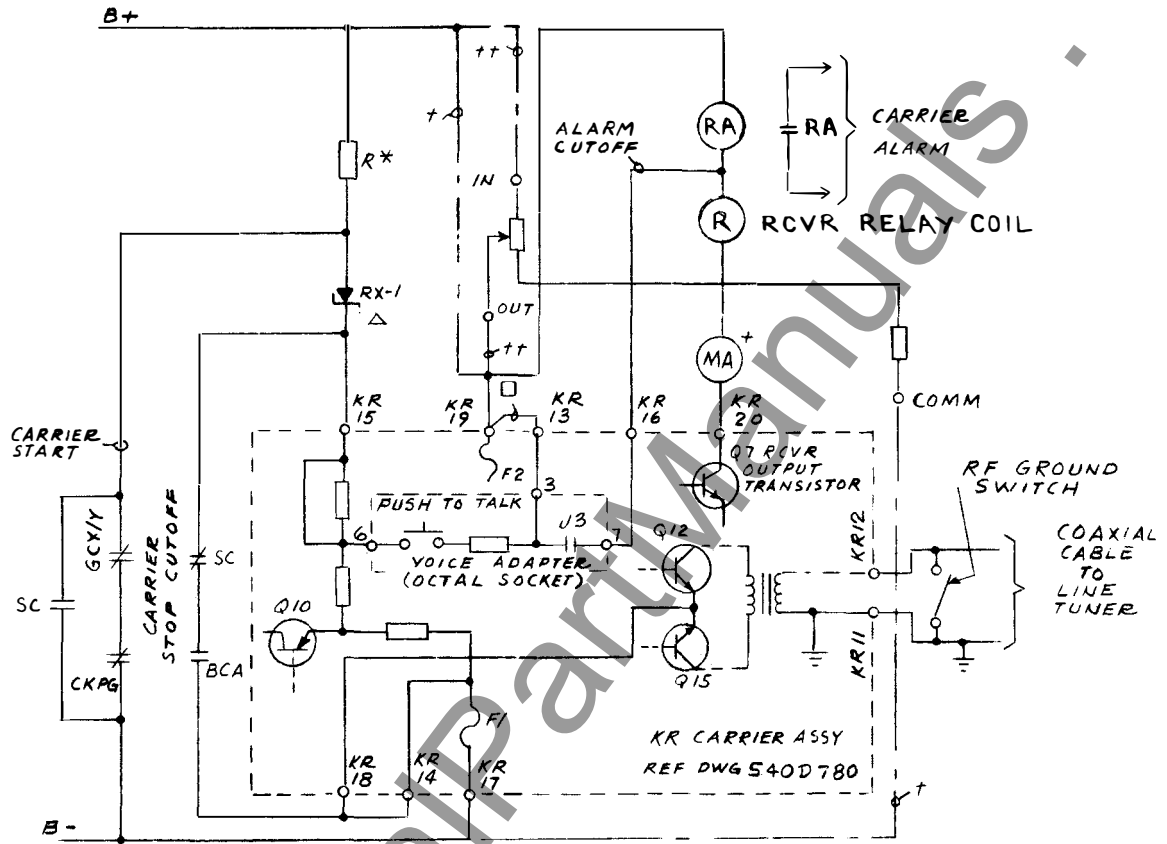

REQUIREMENTS FOR GCX/GCY RELAYING

SUPPLY VOLTAGE	CARRIER START	CARRIER STOP	R
51 VDC	+37V, 7MA	0 VOLTS	2K
129 VDC	+100V, 8MA	0 VOLTS	3.75K
258 VDC	+100V, 8MA	0 VOLTS	19.K

KR RELAYING TRANSMITTER /
RECV. EXTERNAL CONNECTIONS
TERMINAL- CONNECTION

- 11. GROUND
- 12. COAXIAL CABLE
- 13. SUPERVISORY PREFERENCE CONTACT
- 14. CARRIER STOP B- RETURN
- 15. CARRIER START (POSITIVE)
- 16. ALARM CUTOFF FOR COMMUNICATIONS
- 17. B MINUS
- 18. CARRIER STOP (HZ/HZM)
- 19. B PLUS
- 20. RELAY COIL

NOTES

- * FOR "R" USE OHMITE VITREOUS ENAMELED DIVIDOHM ADJUSTABLE 4K OR 20K 25W RESISTOR, CONNECT & ADJUST FOR VALUES SHOWN
- Δ TYPE IN3051
- + FOR 51 & 129 VDC SUPPLY
- ++ FOR 258VDC SUPPLY USE 330C191H01 RESISTOR UNIT REF DWG 223B497
- FOR SUPERVISORY CONTROL PREFERENCE CONTACTS

* Fig. 5. Relaying Control Circuits-GCX/GCY (Dwg. 2-329C704)

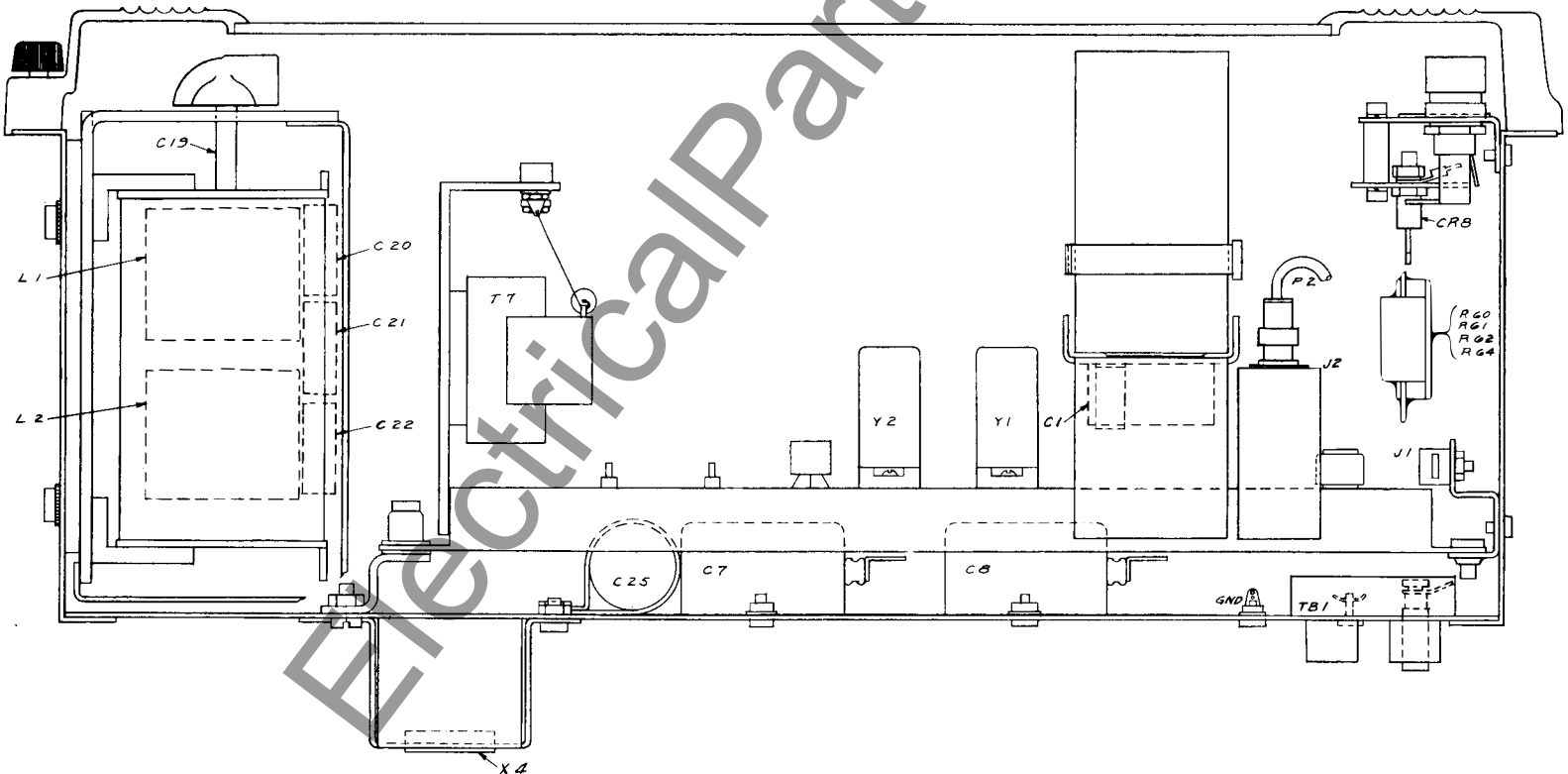
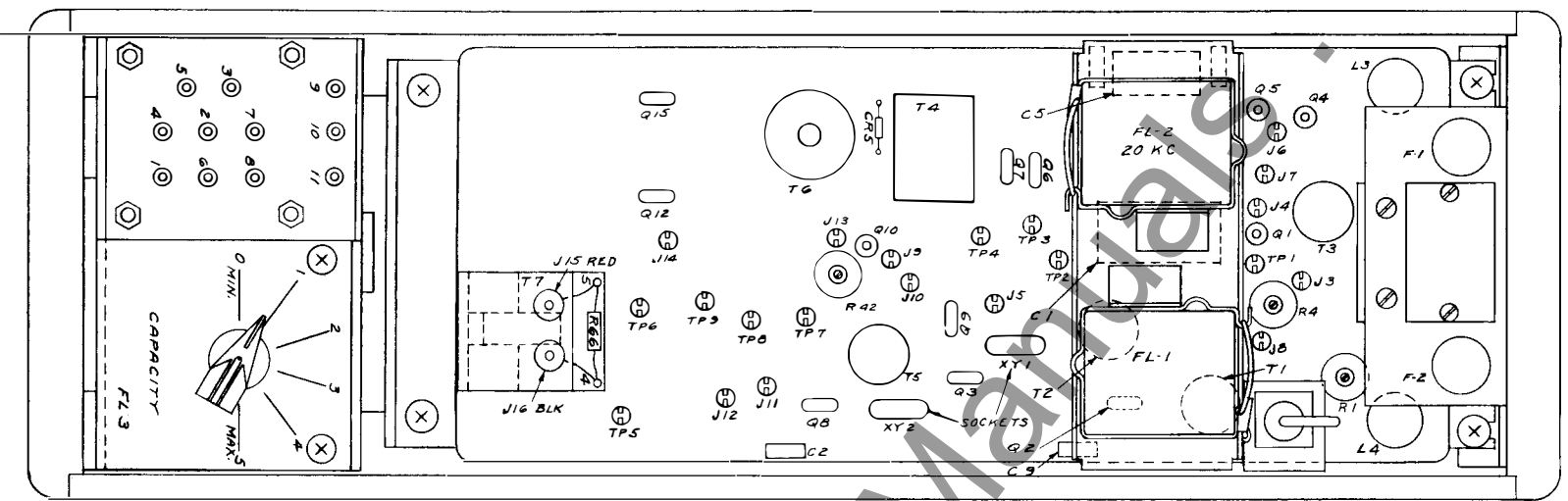
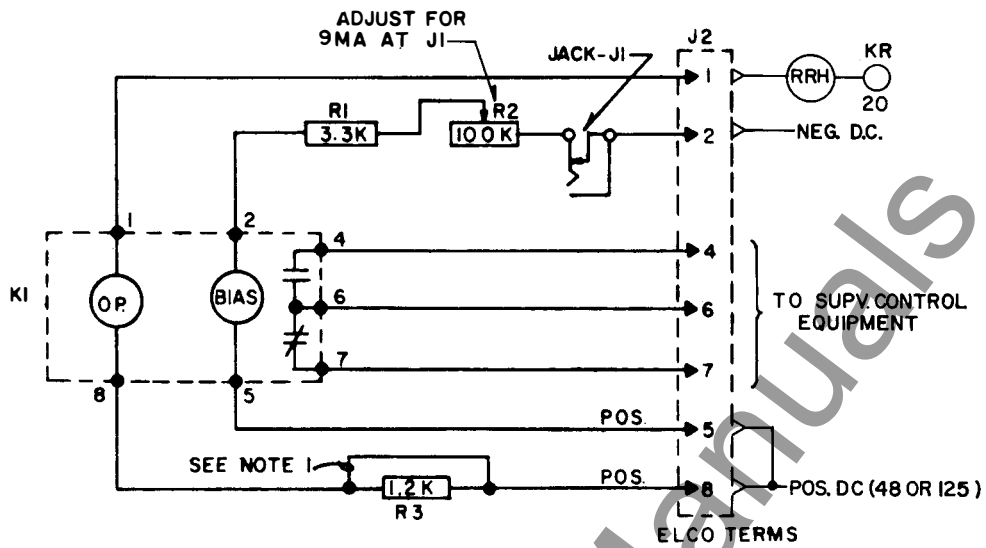

Fig. 6. Component Location (Dwg. 540D781)



NOTES:

1. REMOVE FOR KR CARRIER PLUS SUPV. CONTROL WITHOUT RELAYING.
2. POLARITY SHOWN CLOSES CONTACT BETWEEN TERMINALS 4 & 6.

J 2			
1	2	3	4
5	6	7	8

AS VIEWED FROM REAR OF PANEL

629A552

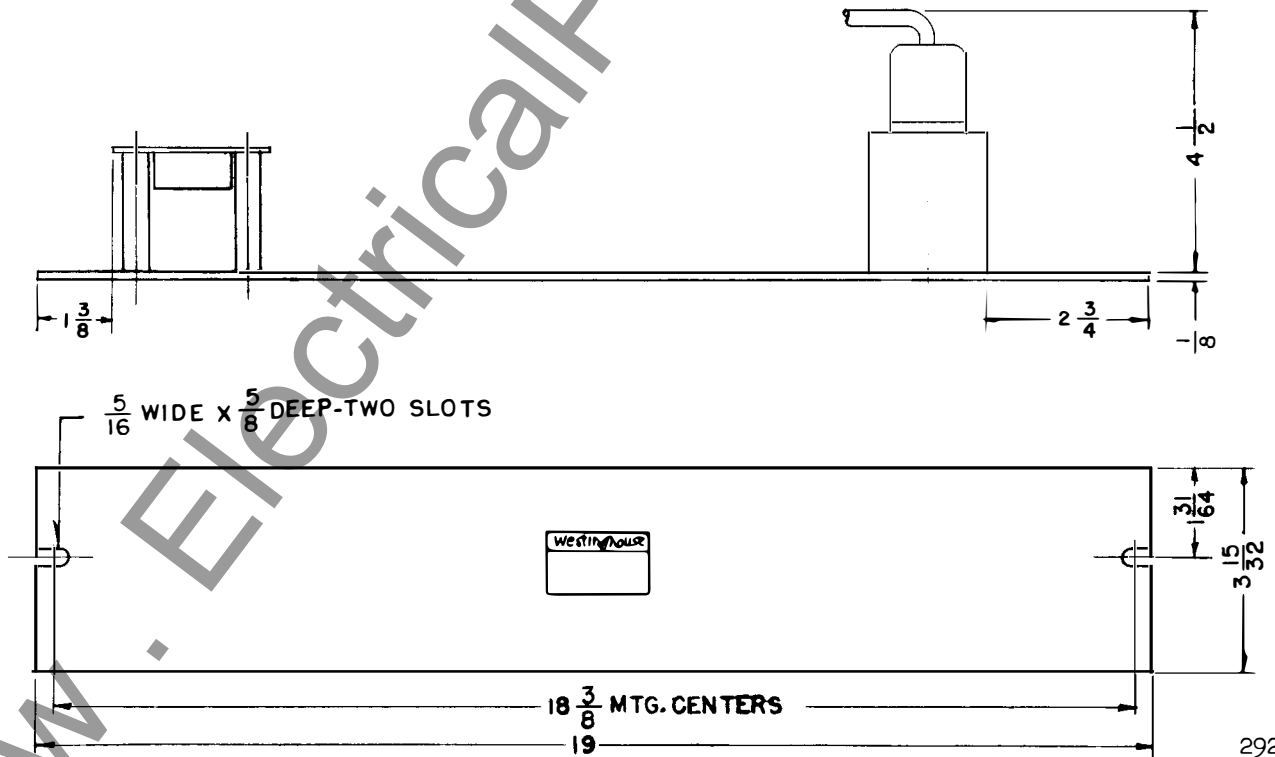

292B991

Fig. 7. Supervisory Control Auxiliary Relay Connections (Dwg. 629A552) and Outline (Dwg. 292B991).

**CONNECTIONS FOR 48-250 VOLT SERVICE AND
SUPERVISORY CONTROL APPLICATION
(CHANGES FROM JUMPERS SHOWN ON INTERNAL SCHEMATIC, FIG.2)**

250-VOLT OPERATION

FOR A 250 VOLT SUPPLY, RESISTOR UNIT 330C191M01 IS USED AS SHOWN ON APPLICATION DRAWING 329C704

FOR HZ/HZM OPERATION, THE JUMPER HAS BEEN REMOVED FROM TP-6 TO TP-7. (NOT REMOVED FOR K-DAR RELAYING).

RESISTOR UNIT SCHEMATIC:

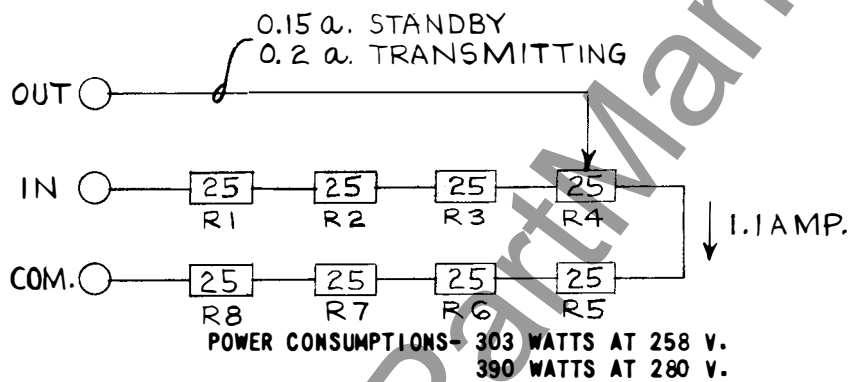

NOTE: KR SUPPLY VOLTAGE WILL BE APPROXIMATELY 144 VOLTS UNDER STANDBY CONDITION WHEN BATTERY VOLTAGE IS 280 VOLTS.

125-VOLT HZ/HZM OPERATION

JUMPER TP-7 AND TP-8 IS REMOVED.

48 VOLT OPERATION

ON PRINTED CIRCUIT BOARD ADDITIONAL JUMPERS ARE CONNECTED AS FOLLOWS:

- BETWEEN TP8 AND TP9
- BETWEEN TP5 AND J12
- BETWEEN TP1 AND TP2
- BETWEEN TP3 AND TP4

IN THE FT CASE, JUMPERS ARE CONNECTED ACROSS R60 AND R64, AND THE CONNECTION BETWEEN R64 AND DIODE CR8 IS REMOVED.

IN ADDITION, FOR 48-VOLT SUPERVISORY CONTROL, R59 IS CONNECTED INTO THE CIRCUIT.

Fig. 8. Connections, 48-250 Volts and Supervisory Control (Dwg. 407C971)

TRANSMITTER OUTPUT FILTER FL-3 CONNECTIONS

<u>LINE</u>	<u>FREQUENCY RANGE</u>	<u>COIL</u>	<u>COIL CONNECTIONS</u>	<u>PARALLEL CAPACITOR CONNECTIONS</u> Δ
1	27.7 KC-30.0 KC	L-1	(1-5) (3-6)	6-8-9-10-11
2	29.8 KC-33.1 KC	L-1	(1-5) (3-6)	6-8-10-11
3	31.8 KC-36.0 KC	L-1	(1-5) (3-6)	6-8-9-11
4	35.4 KC-39.0 KC	L-1	(1-5) (3-6)	6-8-11
5	38.0 KC-41.0 KC	L-1	(1-2) (3-6)	6-8-9-10-11
6	40.3 KC-45.0 KC	L-1	(1-2) (3-6)	6-8-10-11
7	43.0 KC-49.0 KC	L-1	(1-2) (3-6)	6-8-9-11
8	47.7 KC-56.0 KC	L-1	(1-2) (3-6)	6-8-11
9	49.5 KC-58.5 KC	L-1	(1-2) (3-6)	6-8-9-10
10	57.0 KC-72.3 KC	L-1	(1-2) (3-6)	6-8-10
11	67.0 KC-76.0 KC	L-2	(1-4) (6-7)	6-8-9-11
12	75.0 KC-88.0 KC	L-2	(1-4) (6-7)	6-8-11
13	77.5 KC-93.0 KC	L-2	(1-4) (6-7)	6-8-9-10
14	89.3 KC-114.5KC	L-2	(1-4) (6-7)	6-8-10
15	102.7KC-147.0KC	L-2	(1-4) (6-7)	6-8-9
16	136.6KC-210.0KC	L-2	(1-4) (6-7)	6-8

Δ CONNECTION FROM 6 TO 8 IS MADE BENEATH TERMINAL PLATE ON ALL SETS AT THE FACTORY.

Fig. 9. Connections - Output Filter (Dwg. 149A420)

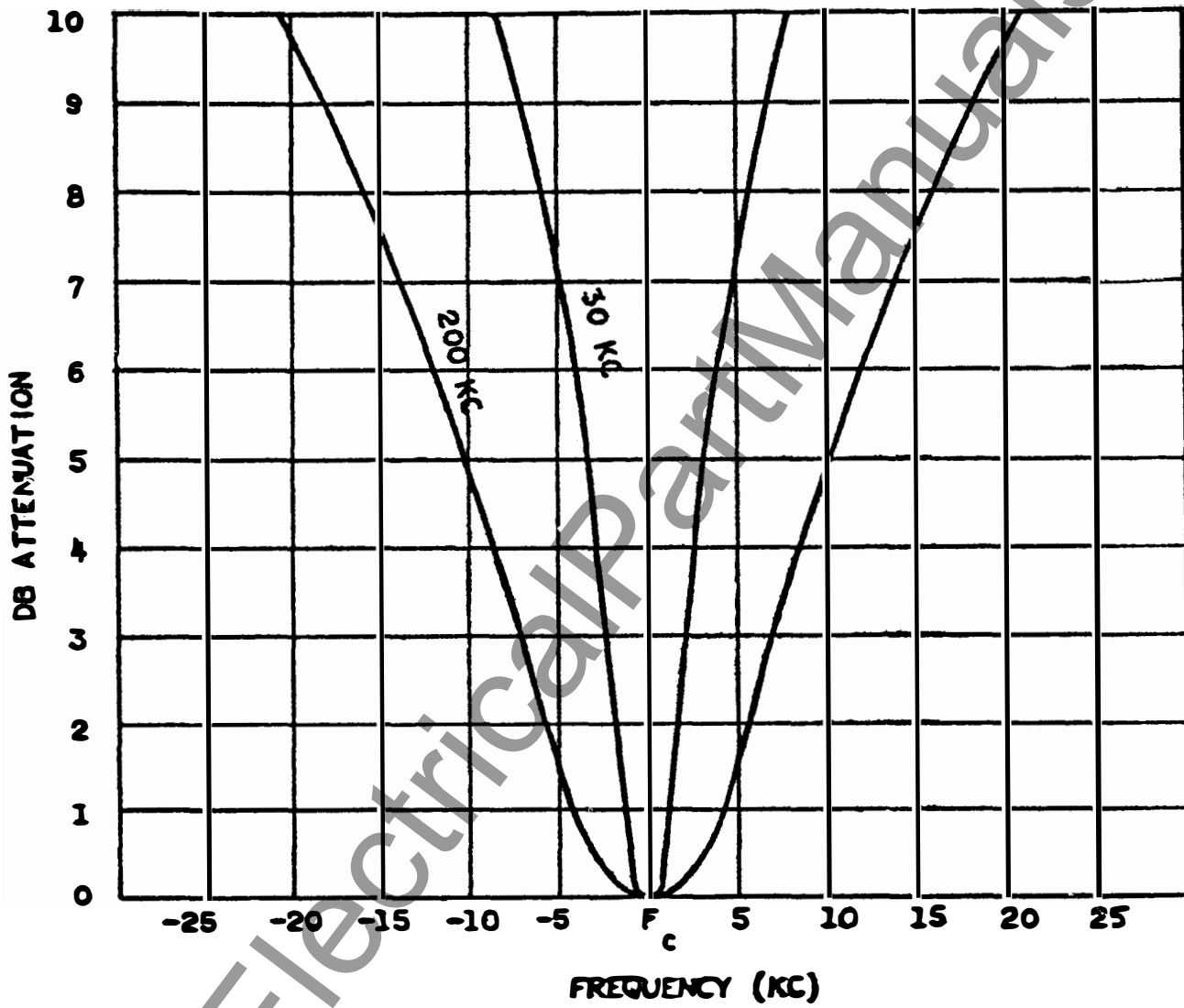

Fig. 10. Transmitter Output Filter Selectivity (Dwg. 377996)

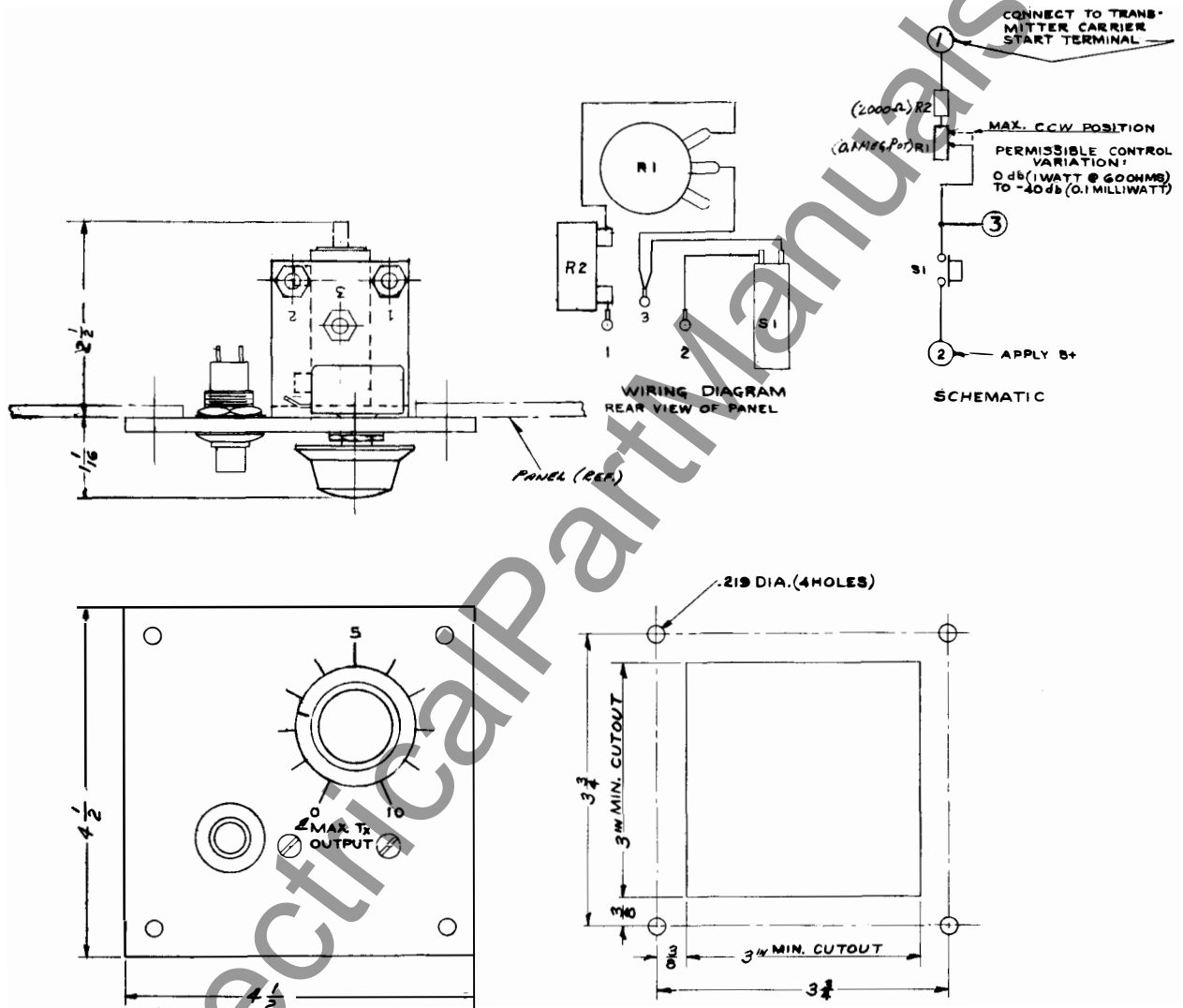

Fig. 11. Reserve Signal Detector Outline (Dwg. 329C703)

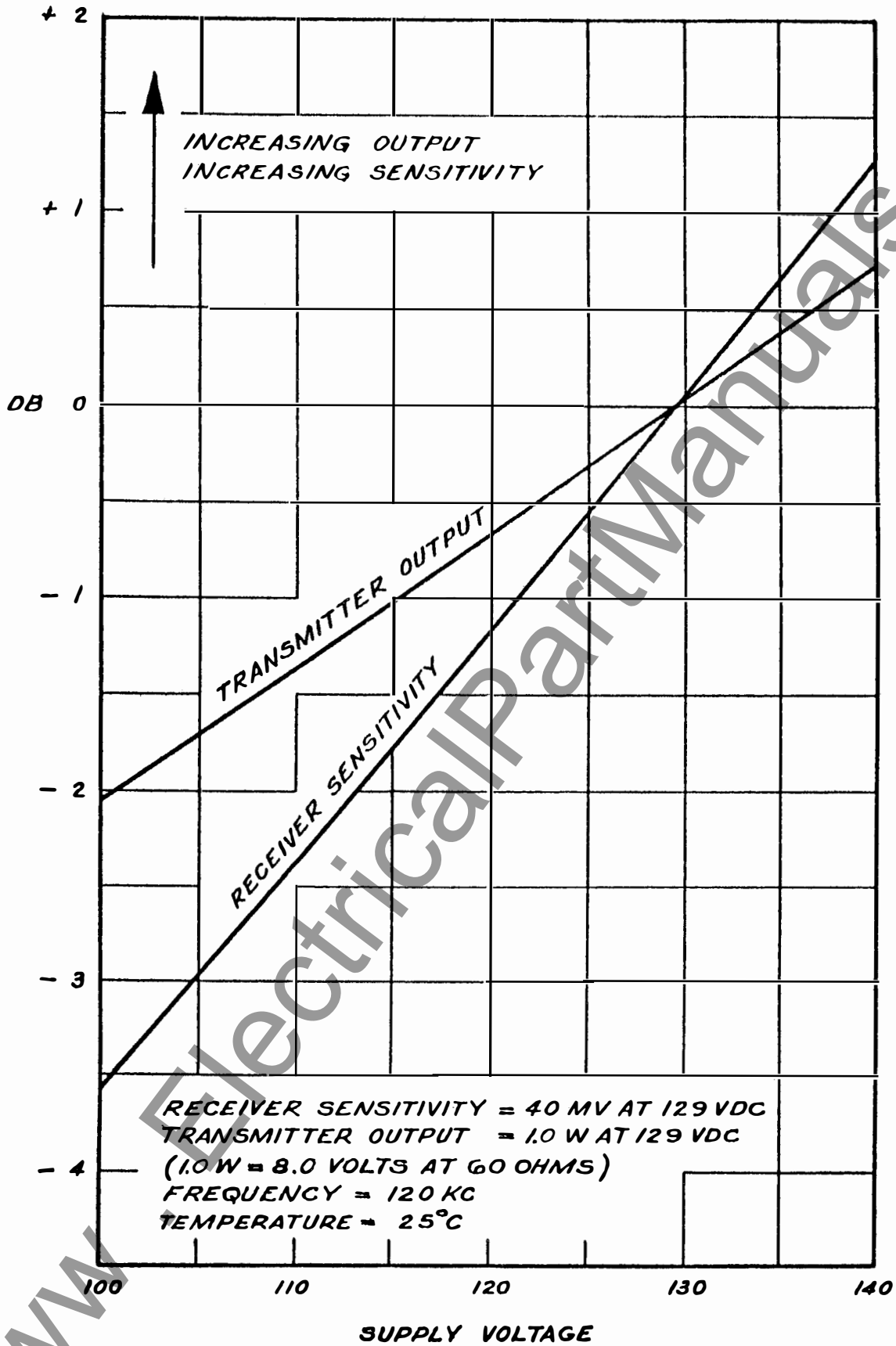

Fig. 12. Transmitter Output and Receiver Sensitivity Variations with Voltage (Dwg. 377999)

TRANSMITTER OUTPUT & RECEIVER SENSITIVITY
VARIATIONS WITH FREQUENCY

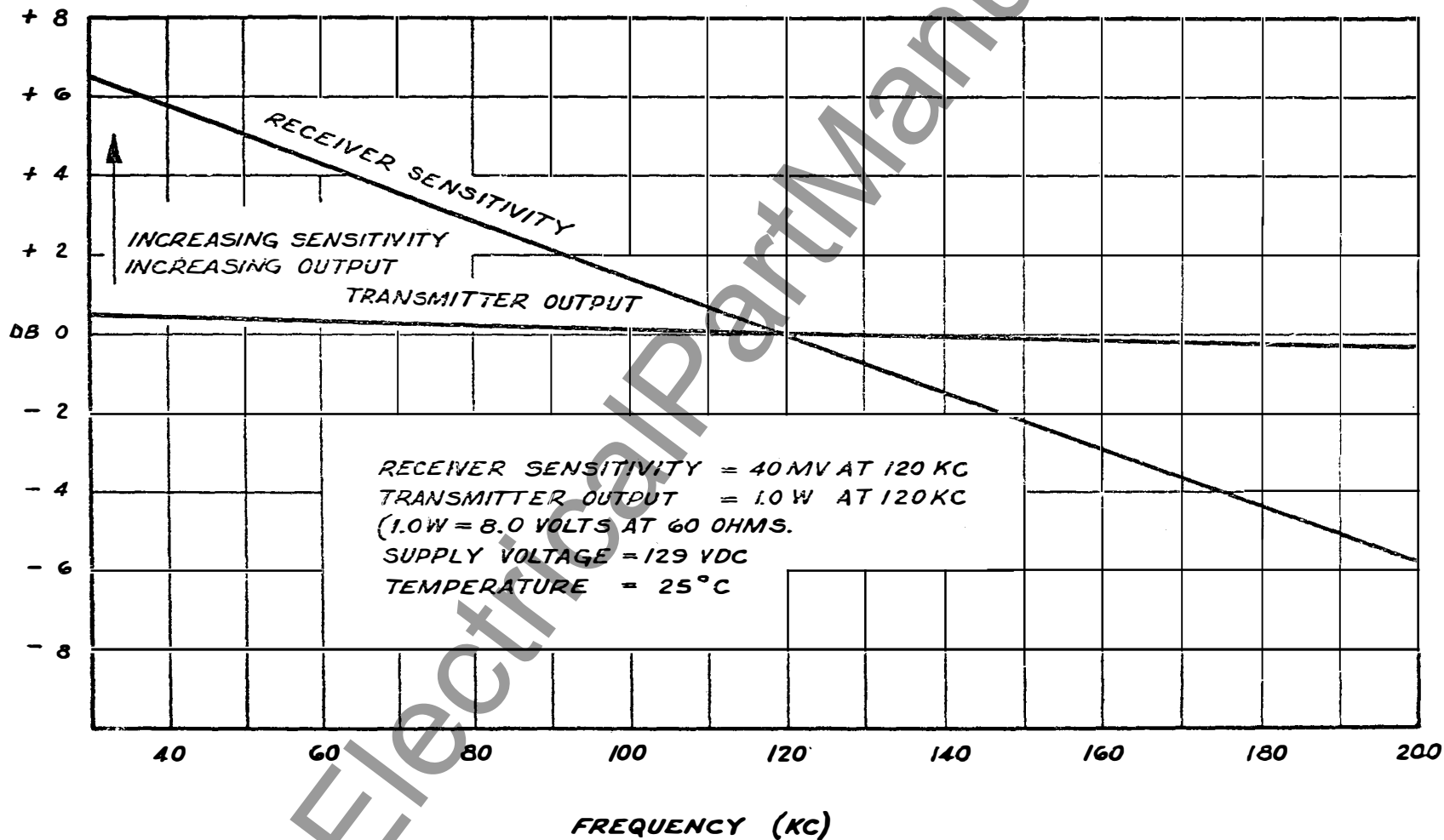

Fig. 13. Transmitter Output and Receiver Sensitivity Variations with Frequency (Dwg. 378000)

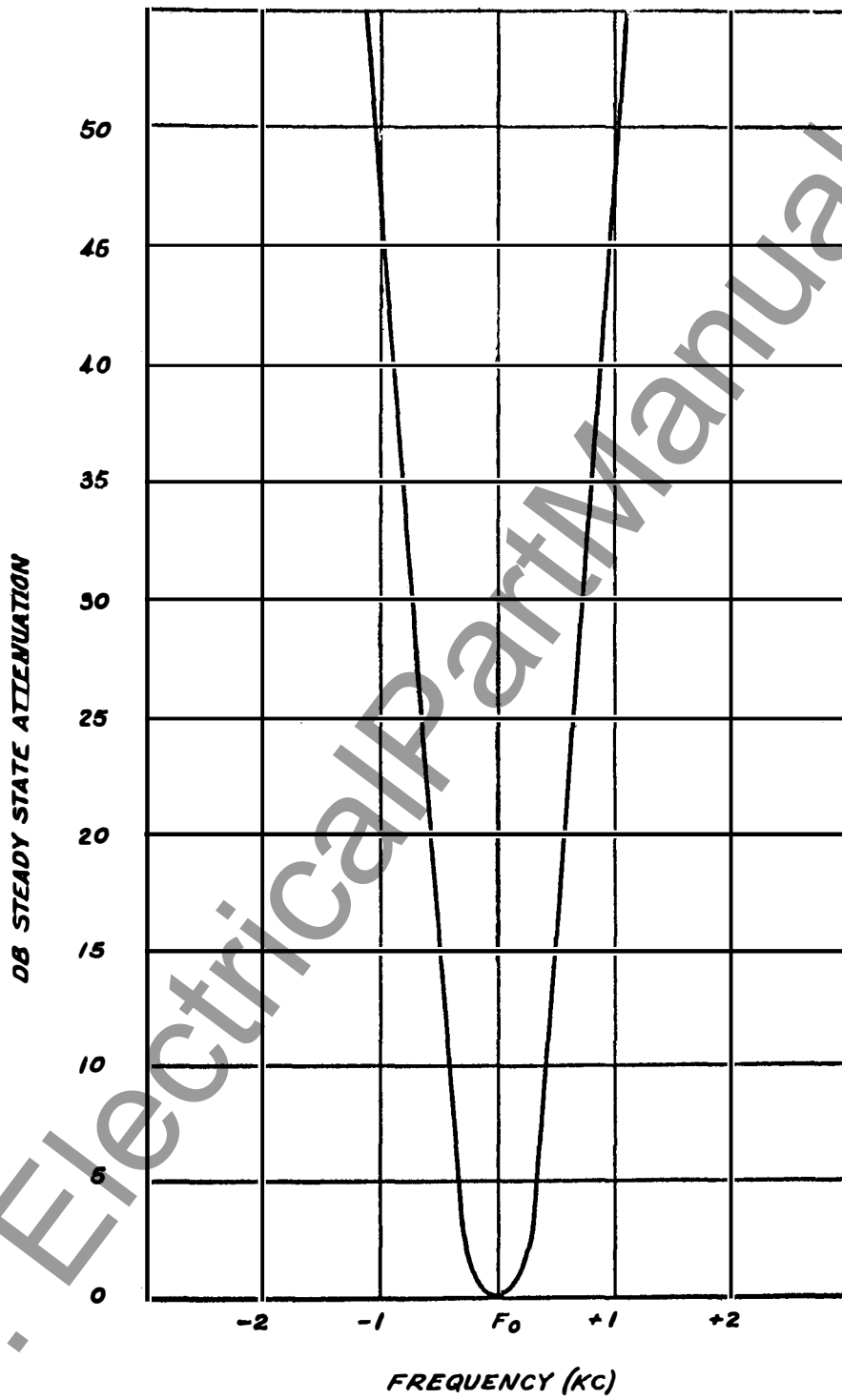
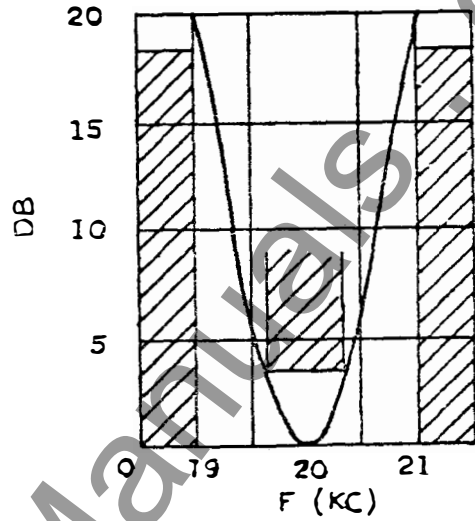
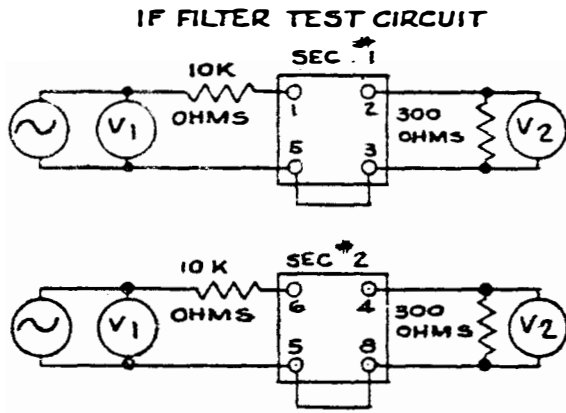
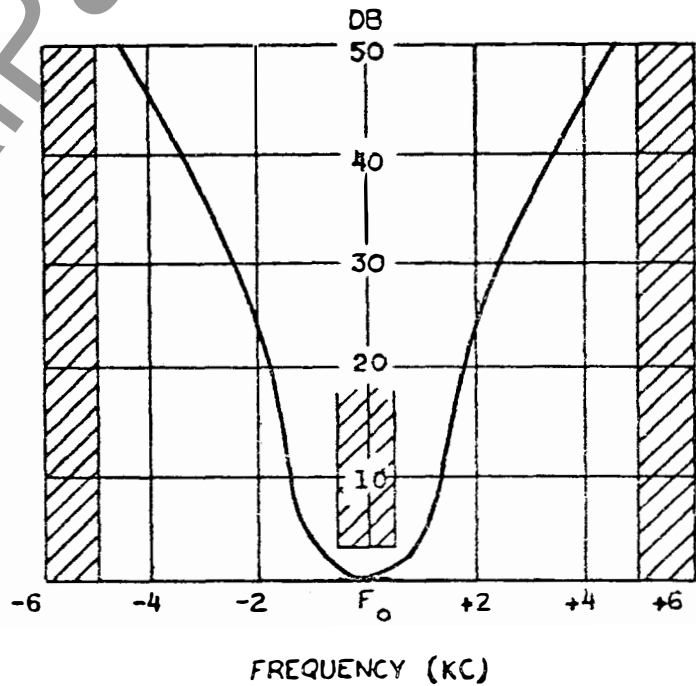
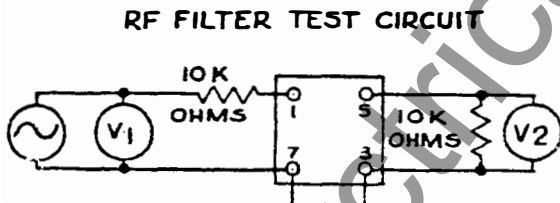

Fig. 14. Receiver Selectivity (Dwg. 377993)



Each section FL-2 requirement
with typical selectivity curve
Insertion loss 26 DB max.
Including matching resistor.



FL-1 Requirement with typical selectivity
curve at 120 KC. Insertion loss 18 DB
max. Including matching resistor.

Fig. 15. Receiver Filter Limits (Dwg. 377995)

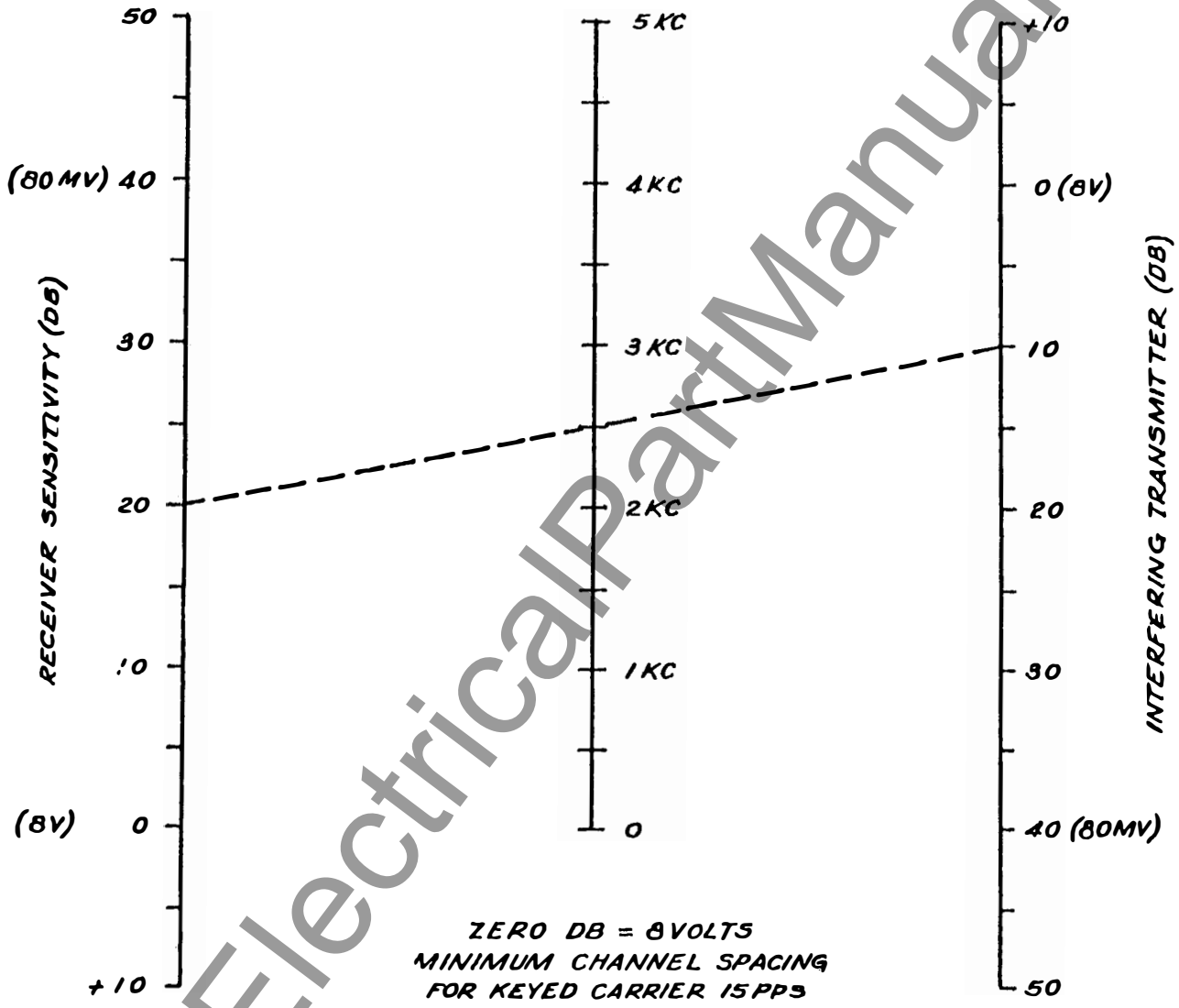
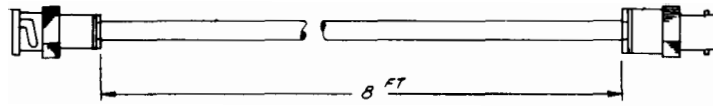
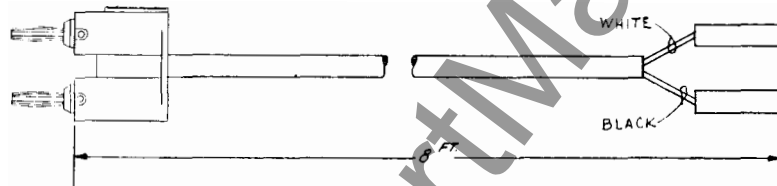

Fig. 16. Minimum Channel Spacing (Dwg. 377998)



Coaxial Lead... 756D346 G02



Output Lead... 756D346 G03

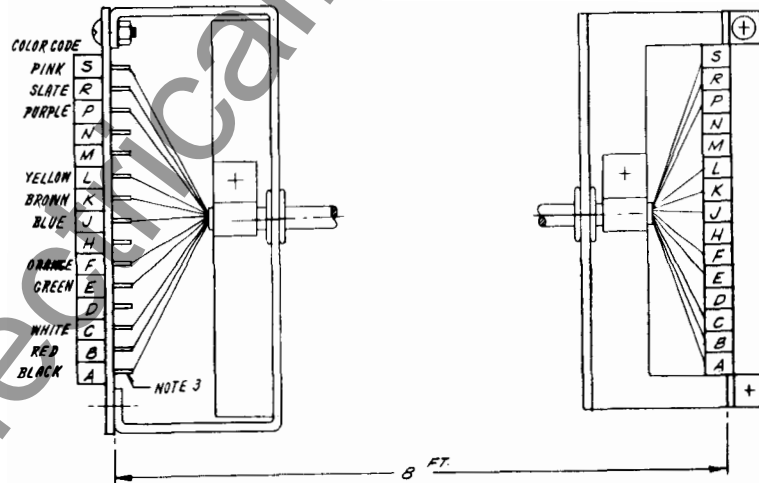

Main Harness... 756D346 G04

Fig. 17. Test Harness - (Complete Set)

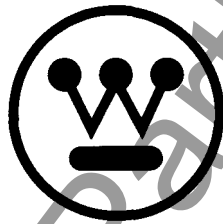

WESTINGHOUSE ELECTRIC CORPORATION
RELAY-INSTRUMENT DIVISION

NEWARK, N. J.

Printed in U.S.A.



INSTALLATION • OPERATION • MAINTENANCE I N S T R U C T I O N S

TYPE KR CARRIER RELAYING TRANSMITTER-RECEIVER

Flexitest Case Mounted —with provision for rear-mounter Voice Adapter Accessories.	Style
KR Sleet Detector	470D167 G01
250 Volt Resistor Unit	330C191 H01
Test Harness (Complete Set)	756D346 G01
Coaxial Lead	756D346 G02
Output Lead	756D346 G03
Main Harness	756D346 G04

TABLE OF CONTENTS

Introduction	Page 2
Specifications	Page 2
Description	
General	Page 3
Mechanical	Page 3
Electrical	
Transmitter	Page 4
Receiver	Page 4
Transmitter Control Circuits	Page 5
Sleet Detector	Page 5
Communications	Page 5
Relaying Control Circuits	Page 5
Installation	
General	Page 6
Connections	
External	Page 6
Internal	Page 7

Adjustments

Transmitter	Page 7
Receiver	Page 7
Sleet Detector	Page 8
250-Volt Resistor Unit	Page 8
Frequency Change	Page 8
Maintenance	Page 9
Application	Page 13
Electrical Parts List	Page 14

LIST OF TABLES

Table	
1 D-C Pin Jack Measurements with Reference to B-	Page 10
2 Transistor DC Measurements with Reference to B-	Page 11
3 D-C Bleeder Measurements with Reference to B-	Page 12
4 Typical RF Signal Measurements for Receiver	Page 12
5 Typical RF Signal Measurements for Transmitter	Page 13

LIST OF ILLUSTRATIONS

Figure	References
1 Outline – Flexitest Case	540D753
2 Internal Schematic	540D780
3 Relaying Control Circuits (HZ/HZM)	1-329C704
4 Relaying Control Circuits (K-Dar)	3-329C704
5 Relaying Control Circuits (GCX/GCY).....	2-329C704
6 Component Location.....	540D781
7 Supervisory Control Receiver Connection.....	223B498
8 Connections, 48-250 volts and Supervisory Control.....	407C971
9 Transmitter Output Filter Connections	149A420
10 Transmitter Output Filter Selectivity.....	C377996
11 Sleet Detector – Outline and Schematic	329C703
12 Transmitter Output and Receiver Sensitivity Variations with D-C Voltage	C377999
13 Transmitter Output and Receiver Sensitivity Variations with Frequency.	C378000
14 Receiver Selectivity	C377993

15 Receiver Filter Limits	C377995
16 Minimum, Channel Spacing	C377998
17 Test Harness	756D346

CAUTION The voltages encountered in this equipment are dangerous to life. To be safe, disconnect the power source and close the grounding switch when servicing the equipment.

INTRODUCTION

The Type KR Relaying Transmitter-Receiver is designed for Distance Relaying, Telemetering, Supervisory Control and Sleet Detection. Facilities are provided for a plug-in type voice adapter. The basic design is for operation from 125-volt station batteries. However, the apparatus may also be operated from 48-volt or 250-volt station batteries by means of various internal connections. These various connections as well as most of the adjustments are made at the factory, although they can be changed in the field.

Although designed primarily for operation with Westinghouse protective relays, this apparatus may also be coordinated with other types of directional-distance relays and with most other contact keyed devices.

SPECIFICATIONS

Frequency Range.....	30-kc to 200-kc
Channel Attenuation Rating	40-db
Transmitter Power Output	1.0 watt at standard conditions (see Figs. 12 and 13). 0.5 watt with a 48-volt d-c supply.
Transmitter Harmonic Output	At least 46-db below fundamental.
Transmitter Output Impedance.....	Matches one 60-ohm coax. cable. (Suitable for 50-70 ohm cable.)
Transmitter Output Filter Selectivity	See Fig. 10
Transmitter and Receiver Oscillator and Frequency Stability	From -20 °C to +50 °C with simultaneous voltage variations from 100 to 140 VDC, the frequency remains with 0.01%.

Permissible Battery Voltage Ripple	7-1/2%
Ambient Temperature Range	-20°C to +50°C.
Non-Operating Temperature Range	-40°C to +70°C
Receiver Sensitivity	0.04 volts at standard conditions (see Figs. 10 and 18).
Receiver Selectivity	See Fig. 14
Receiver Signal-to-Noise Ratio Requirements	12 db
Minimum Channel Spacing	See Fig. 16
Power Input	115-ma at 48 VDC, 200-ma at 125 VDC, 1.28 amperes at 250 VDC.
Carrier On-Off Keying	Requires one pair of contacts capable of keying 8-ma DC at an open circuit voltage of 125 VDC.
Weight (With Flexitest Case)	Approximately 16-lbs.

CAUTION Refer application to Westinghouse when other transmitters are to be connected to the same coax cable as certain conditions may result in damage to the output transistors.

NOTE Standard conditions are taken as 129-volts, 120-kc and 25°C.

DESCRIPTION

General

This completely transistorized carrier-apparatus is a result of extensive field and laboratory tests. From these tests, it was proven that transistors provide superior reliability over tubes. In addition, the latest printed circuit and filter techniques have improved performance and greatly decreased the size. The expected long life of transistors as compared with vacuum tubes will reduce maintenance costs, and the low power requirements will produce important savings in battery and charger requirements.

Transistors perform the same functions as vacuum tubes. However, tubes operate by the flow of electrons in a vacuum between elements, while transistors depend upon the movement of electrons in a solid. This leads to a more rugged type of construction. Most transistors are made from either germanium

or silicon semi-conductor materials. The junction transistor consists of a thin slice of germanium or silicon with three different regions produced by introducing specific amounts of impurities. A thin wire is connected to each region. One outer region is called the emitter, the other the collector, and inserted between them is the base. These correspond roughly to the cathode, plate, and grid of a vacuum tube.

The transistors in this equipment are of the junction type, and both NPN and PNP configurations are used. In the NPN transistor, the majority of the current is carried by electrons. In the PNP transistor there is a deficiency of electrons. These deficiencies are known as "holes". For practical purposes holes may be considered as positively charged "electrons", and these provide most of the current flow in PNP units. In order to obtain maximum efficiency and reliability, both types are used in this equipment.

Silicon transistors are used in the transmitter and receiver output circuit in order to stabilize critical circuit performance at elevated temperatures.

Mechanical

This apparatus is supplied in a Flexitest case and may be either flush or projection mounted in

TYPE KR CARRIER SET

order to match other switchboard equipment. The outline dimensions and also the drilling plan for flush and projection mounting are shown by Fig. 1. The majority of the parts are mounted on a printed circuit board. This board may be readily removed as follows:

1. Remove the two output plugs from the red and black jacks.
2. Disconnect the receiver input coaxial cable connector.
3. Loosen the two screws at the top of the board.
4. Loosen the two screws at the bottom of the board and pull them out as far as they will extend.
5. Pull board down to disengage the terminals and lift out.

The transmitter output filter may be removed by removing four mounting screws from the bottom of the case and disconnecting the coaxial cable.

Fig. 6. shows the location of major components such as potentiometers, jack, test points, crystals, transistors, etc. External connections and the Schematic Diagram are shown by Fig. 2. The numbered terminals shown as squares apply to the external terminals.

Provisions are made for plugging the Voice Adapter Unit in the rear of the relaying equipment. Octal socket marked X-4 on the rear of the set accommodates the adapter plug. A buckle type strap on each side of the adapter holds the unit in place after it has been plugged in. The normal projection for a rear mounted Voice Adapter is 3-inches beyond that of the relaying equipment. When the KR Relaying Unit is supplied with the adapter, a patch cord is available on separate order. This patch cord plugs into the telephone jacks on the adapter and provides an extension to a conveniently located terminal board.

The panel cutout information necessary for mounting the Sleet Detector is shown by Fig. 11. This unit consists of a potentiometer and pushbutton switch mounted on a small panel, itself suitable for switchboard mounting.

For 250-volt operation, separate auxiliary resistors are required, as shown in Fig. 8.

Electrical

Transmitter

The transmitter is made of four main stages in-

cluding an oscillator, driver, power amplifier, and an output filter. In the oscillator, the crystal is operated as a resonant circuit between the collector of one transistor and the base of the other. The feedback is supplied through a capacitor from the collector of the second transistor to the base of the first transistor. The frequency is independent of voltage or temperature changes of the transistors. Thus the frequency stability is the stability of the crystal.

The input to the driver stage Q-10 is controlled by potentiometer, R-42 which also controls the transmitter power output. In HZM relaying CARRIER STOP provides about +40 volts for blocking. This is applied to Q-10 through T-6. Diode CR-5 prevents damage to the transistor when this positive voltage is applied to the collector. For CARRIER START (when in the blocked position) a small positive voltage is applied to the collector of Q-10 by means of bleeder resistors R-67 and R-68.

The power amplifier consists of two transistors Q-12 and Q-15, which are operated as class B amplifiers in push-pull. Resistors R-52 and R-55 are for stabilization.

The output transformer, T-7, matches coaxial cables of 50 to 70 ohms.

Resistor R-66 tends to keep the source impedance constant to permit proper tuning of the output filter.

The output filter consists of coils L-1 and L-2, capacitors C-19 through C-22. The filter is tunable, and is provided to attenuate harmonics and other spurious outputs. It should be noted that the filter contains no shunt elements, resulting in a reverse impedance free of "across the line" resonances.

Receiver

The receiver is a superheterodyne in order to obtain constant selectivity regardless of the channel frequency. (See Fig. 14.) The major stages include an input filter, attenuator, oscillator, mixer, IF filters, IF amplifiers, detector and a D-C power output stage.

The input filter prevents undesired signals from producing the IF frequency.

The receiver sensitivity is adjusted by means of the continuously variable input control R-1 and by

connecting or disconnecting resistors R-73 and R-74 in the IF stages.

The receiver oscillator (Q-2 and Q-3) is basically the same as the transmitter oscillator. The frequency is 20-kc above the incoming signal frequency.

The receiver channel frequency is determined by the input filter and the oscillator crystal. The frequency may be changed readily since both the filter and the crystal are plug-in components.

Mixing is accomplished by feeding the incoming signal to the emitter and the receiver oscillator signal to the base of the mixer Q-1. Mixer oscillator requirements are met through adjustment of potentiometer R-4. Injection into two separate elements, base and emitter, provides a circuit capable of handling greater signal level variations than one in which injection is made into only a single element such as the base.

This receiver uses an IF frequency of 20-kc. The overall selectivity is determined primarily by the IF filter FL-2. Typical characteristics of this filter are shown in Fig. 15.

The IF amplifier consists of transistors Q-4, Q-5 and Q-6.

The detector is a full wave bridge rectifier. This rectifier in conjunction with the IF amplifier Q-6, provides the necessary power to drive the D-C power output stage Q-7.

The final output stage Q-7 will supply approximately 18 milliamperes to a standard 1700 ohm distance relay RRH coil and its associated 500 ohm alarm coil. It may also be used to drive other relay coils such as is shown by Fig. 7, Supervisory Control Connections.

Transmitter Control Circuits

In the standby condition, although the oscillator is running, the transmitter driver has no emitter bias which results in no output.

Positive voltage applied to terminal 15 supplies this bias through a voltage dividing network, and transmitter output results. The actual configuration of the network is a function of supply voltage and application (Relaying, Telemetering, etc.) and is

discussed in the Adjustments section.

Output may be stopped in several ways. The method used with K-DAR relays is to remove the positive voltage applied to terminal 15. In the case of distance relaying with Westinghouse HZ/HZM relays, application of a positive voltage to terminal 18 will stop the transmitter output. Output may also be stopped by removal of negative battery from terminal 18.

Sleet Detector

The Sleet Detector is shown by Fig. 11. Effectively R-1 is a remote transmitter output control. This control is obtained through varying the driver stage (Q-10) emitter bias, and is effective over a 40-db range of transmitter output. The Sleet Detector is switched into service by S-1. By adjusting R-1 for a given receiver relay current at the far end of the channel, a relative measure of the channel attenuation may be obtained. This is discussed further in the section on Adjustments.

Communications

The transmitter output is reduced approximately 6-db when the Type KR voice adapter attachment is used. Relaying takes preference, and full output is obtained since full voltage is supplied to terminal 15.

Relaying Control Circuits

Figs. 3, 4 and 5 show simplified diagrams of the relaying control circuits.

1. K-DAR and GCY Relaying (Figs. 4 and 5)

The control of the carrier set is obtained through the CARRIER START and CARRIER STOP contacts. These contacts are shown in their normal standby condition.

The K-DAR or GCY relays operating from the voltage and current on the transmission line, detect and determine the direction of a line fault and thereby control the carrier transmitter and receiver.

The control of the carrier set is such as to start the transmission of carrier when fault power on the transmission line is flowing out of the line section being protected. Conversely, when fault power is flowing into this line section, the control is such as to block the transmitter and keep it from being turned on by secondary functions such as sleet detection

TYPE KR CARRIER SET

and communication, should these functions be in use at the same time. Should carrier be received from the remote station, the hold coil and alarm coil will energize through transistor Q-7 in the receiver.

When carrier start operation occurs, the CARRIER START contact opens applying a positive voltage (see Figs. 4 and 5) to terminal 15 of the carrier set. This puts a potential on the driver stage in the transmitter and also applies proper bias for the power amplifier.

When a carrier stop operation occurs, the CARRIER STOP contact closes, which removes B+ (terminal 15) from the driver and the power amplifier stages in the transmitter. CARRIER STOP, terminal 18, on the carrier set is permanently connected to terminal 14, for K-DAR and GCY relaying.

2. HZM Relaying (Fig. 3)

The control of the carrier set is effected by the CARRIER START and the CARRIER STOP contacts. These contacts are shown in their normal standby condition.

The HZ-HZM relays operating from the voltage and current on the transmission line, detect and determine the direction of a line fault and thereby control the carrier transmitter and receiver.

The control of the carrier set is such as to start the transmission of carrier when fault power on the transmission line is flowing out of the line section being protected. Conversely, when fault power is flowing into this line section, the control is such as to block the transmitter and keep it from being turned on by secondary functions such as sleet detection and communication, should these functions be in use at the same time. Should carrier now be received from the remote station, the hold coil and alarm coil will energize through transistor Q-7 in the receiver.

When carrier start operation occurs, the CARRIER START contact closes applying the full battery supply voltage to terminal 15 of the carrier set. This puts a potential on the driver stage in the transmitter and also applies proper bias for the power amplifier.

When a carrier stop operation occurs, the CARRIER STOP contact opens. This applies a positive voltage (see Fig. 3) to terminal 18 which blocks the driver stage and the power amplifier stage

It is possible under certain conditions that the signals from two transmitters, attempting to block a third receiver, would be of such amplitude, phase and frequency as to cause the RRH coil current to "pulsate". It would then be possible to have a false trip.

In the case of the KR set for relaying 3-terminal lines, the transmitter frequencies (to avoid this possibility of false trip) should be separated by 100 cycles. All receivers and one transmitter would be for the desired center frequency. One of the other transmitters would be 100 cycles above, the other 100 cycles below this center frequency.

INSTALLATION

General

Upon receipt of a unit, whether shipped separately or in an assembly, an immediate inspection should be made. Carefully check for damage or shortages.

For necessary clearances and mounting dimensions, see the following illustrations:

- Flexitest Case Mounting..... Fig. 1
- Sleet Detector..... Fig. 11

Connections

External

The external connections will vary slightly depending on the application, but in general will be along the lines described as follows: (Refer to the Schematic Diagram, Fig. 2.)

- Terminals 11..... Ground
- 12..... Coaxial Cable
- 13 and 19..... Supervisory Preference Contacts
- 14..... B- "CARRIER STOP" return
- 15..... Battery positive through carrier start contacts
- 16..... Battery positive for alarm cutoff (used with communication)
- 17..... B-
- 18..... Carrier Stop for HZM Relaying
- 19..... B+
- 20..... Relay Coil

CAUTION If the transmitter output load is removed while the transmitter is energized, the transistors in

the power amplifier will be permanently damaged. A dummy load should be connected to the transmitter output if the coax is disconnected and the transmitter is to be energized.

When tuning line coupling equipment, short the coaxial cable to ground before changing taps on the Line Tuner or matching transformer.

Internal

Necessary internal connections are generally made at the factory, to customer order, before apparatus shipment. For reference purposes, these are outlined in the following tabulation. Check the proper bleeder resistors before applying voltage to the equipment.

OPERATION	BLEEDER RESISTORS IN THE CIRCUIT
48-Volt K-DAR, HZM, and GCY Relaying, Telemetering, and Supervisory	R-47 and R-48
125-Volt K-DAR and GCY Relaying	R-45, R-47 and R-48
125-Volt HZM Relaying, Telemetering, and Supervisory	R-41, R-45, R-47 and R-48
250-Volt K-DAR and GCY Relaying	R-39, R-40, R-45, R-47 and R-48
250-Volt HZM Relaying, Telemetering, and Supervisory	R-39, R-40, R-41, R-45, R-47 and R-48

Various combinations of the inductors and capacitors of the transmitter output filter are required depending on the channel frequency. These are tabulated in Fig. 9.

Adjustments

This apparatus is generally tuned to and tested at the specified channel frequency before shipment. Final adjustments must be made in the field and are described in the following paragraphs. Fig. 6 shows the locations of the various controls.

Transmitter

1. Disconnect the coaxial cable and replace with a 50, 60, or 70 ohm non-inductive resistor depending on the characteristic impedance of the cable used.

2. Fig. 9 shows typical output filter connections for various frequency ranges. In some cases it may be necessary to use either a higher or lower range to tune the filter to resonance.

3. Insert fuses F-1 and F-2 to apply power to the apparatus.

4. Connect an A-C Vacuum Tube Voltmeter (VTVM) across the non-inductive load.

5. Unblock the transmitter by closing the CARRIER TEST SWITCH. An alternative is to jumper battery positive to terminal 15.

6. Beginning with the output control R-42 at the maximum counterclockwise position, advance it clockwise until a reading appears on the VTVM. Tune capacitor C-19 for a maximum voltmeter reading.

7. While increasing R-42, tune the output filter for maximum output until the output across the resistor is approximately 8 volts. (See Figs. 12 and 13.) (Approximately 5.5-volts when operating from 51-volt station battery.)

8. Open the test switch and reconnect the coaxial cable.

Receiver

1. The oscillator output control R-4 is pre-set at the factory. However, should any of the oscillator components be changed (including the transistors and the crystal) R-4 will require adjustment.

a. Connect an A-C VTVM to jacks J-3 and J-4.

b. Adjust R-4 for a 0.3 volt reading on the meter.

2. The unit is shipped to have a gain of approxi-

mately 250 millivolts (to produce 10 ma relay current) with input control R-1 in maximum clockwise position. About 10-db additional gain or 80 millivolt sensitivity can be obtained by clipping out resistor R-74, which is connected to the base of Q-4 and the B+ supply for the IF. Approximately 10-db gain or 25 millivolt sensitivity can be obtained by clipping out resistor R-73, which is connected to the base of Q-5 and the B+ supply for the IF. Resistor R-71 has been selected at the factory to provide an overall gain of approximately 25 millivolts.

a. Sensitivity Adjustment for Noise

If the maximum on-frequency noise level is known or can be measured, the receiver can be adjusted for this level. Disconnect the coaxial cable and connect a 60-ohm non-inductive resistor and a VTVM across terminals 11 and 12. Energize the transmitter and output control R-42 for the same output as the maximum noise. Then adjust the receiver input control R-1 to obtain 1-ma output current. If it is impossible to obtain 1-ma output current with control R-1 in the maximum clockwise position, then clip out resistor R-74, which is connected to the base of Q-4. If the gain is still insufficient, clip out resistor R-73, which is connected to the base of Q-5. After completing the adjustment of R-1, restore the transmitter to full output.

b. Sensitivity Adjustment for Remote Signal

When the maximum on-frequency noise is unknown and cannot be conveniently measured, the receiver may be adjusted for the remote signal. First determine the channel attenuation using a Sierra voltmeter or some other convenient method. Disconnect the coaxial cable and connect a 60-ohm non-inductive resistor and a VTVM across terminals 11 and 12. Add 15-db to the channel attenuation. This compensates for average variations such as channel and voltage variations. For example, if the channel attenuation is 5-db, add this to the 15-db making a total of 20-db. Taking this from 8 volts output of the transmitter, the receiver should then be set for a sensitivity of 0.8 volts. To do this, adjust the transmitter output control R-42 for 0.8 volts and then adjust the receiver input control so as to obtain 10-ma output current. If it is impossible to obtain 10-ma output current with control R-1 in the maximum clockwise position, clip out resistor R-74, which is connected to the base of Q-4. If the gain is still insufficient, clip out resistor R-73, which is connected to the base of Q-5. After completing the

adjustment of R-1, restore the transmitter to full output.

It must be kept in mind that the two preceding adjustment procedures are to be used as a guide and will cover the majority of cases; however, cases may arise where conditions change. For example, if the adjustment is made per part a., the noise may increase due to various reasons such as bad insulators, which would require adjusting the receiver to be less sensitive. In the adjustment of part b., the attenuation may increase due to sleet or line switching, which would necessitate increasing the sensitivity of the receiver.

Sleet Detector

Due to different types of operation and supply voltages, it is not practical to have a calibrated dial for this unit. However, calibration may be made at installation by recording transmitter output (either in db or volts) at various knob settings of the sleet detector unit. Then, by adjusting the sleet detector so as to obtain 10 milliamperes relay current at a remote receiver, any increase or decrease in line attenuation may be noted as the difference between the original setting, and the setting required to obtain the given 10 milliamperes.

250-Volt Resistor Unit

With the apparatus energized, adjust R-4 in the 250-volt resistor unit so as to obtain 125-volts at terminals 17 (B-) and 19 (B+) on the relaying set.

Frequency Change

If the frequency is changed in the field, it is necessary to change the input filter FL-1 to the desired channel frequency. This filter is of the plug-in type and may be removed by unsnapping the clamp and pulling the filter out. The transmitter oscillator crystal Y-2 must be changed to the desired channel frequency. The receiver oscillator crystal Y-1 must be changed to the desired channel frequency plus 20 kc. Figure 9 shows the connections for the transmitter output filter. It is necessary to unsolder the existing connections and make the new connections per the chart. After completing the preceding, the tuning procedure as described under Adjustments for transmitter and receiver should then be followed.

Note also that capacitors C2 and C9 in the transmitter and receiver crystal oscillator circuits, respectively, may have to be changed. For fre-

quencies below 110 kc, these capacitors are 270 mmf. each. For frequencies of 110 kc and above, the capacitors are 140 mmf. each.

CAUTION Turn power OFF before removing filters or transistors, as high transient currents may cause permanent damage to the transistors.

MAINTENANCE

Voltage values should be recorded after adjustment in order to establish reference values which will be useful when checking the apparatus. The readings will remain fairly constant over an indefinite period unless a failure occurs. However, if transistors are changed, there may be considerable difference in these readings without the overall performance being affected.

Typical voltage and current values are given as follows. Voltages should be measured with VTVM. Readings may vary as much as $\pm 20\%$.

In the following paragraphs, the transmitter may be unblocked (transmitting) by closing the CARRIER START circuit in the case of HZM relaying, and by opening the CARRIER START circuit in the case of K-DAR and GCY relaying.

1. For D-C pin jack measurements with reference to B-, refer to Table 1.
2. For transistor D-C measurements with reference to B-, refer to Table 2.
3. For D-C bleeder measurements with reference to B-, refer to Table 3.
4. For typical RF signal measurements for receiver, refer to Table 4.
5. For typical RF signal measurements for transmitter, refer to Table 5.
6. Removal of Printed Circuit Board from Flexitest Case.

To remove the printed circuit board, unplug J-15 and J-16 located near the output filter. Loosen the two screws inside the case near the top. Loosen the slotted thumb screws at the lower end of the board and pull these screws out as far as they will extend. Also remove the receiver coaxial cable plug.

Pull board down so as to disengage the terminals, and lift out.

7. Removal of the Output Filter

After the printed board has been removed, remove the screws on the outside of the case at the bottom. Lift out filter and disconnect the coaxial cable.

8. Receiver Filters

Fig. 15 shows typical receiver selectivity curves both RF and IF. If the filters are checked in a test setup, it is necessary to use an accurate signal generator or preferably a signal generator and a frequency counter.

9. Minimum Test Equipment for Installation

- a. Milliammeter 0-25 ma DC.
- b. 60-ohm 5-watt non-inductive resistor.
- c. A-C Vacuum Tube Voltmeter (VTVM). Voltage range 0.003 to 30 volts, frequency range 60 cycles/sec to 230-kc, input impedance 7.5 megohms.
- d. D-C Vacuum Tube Voltmeter (VTVM)

Voltage Range: 0.15 to 300 volts
Input Impedance: 7.5 megohms

10. Desirable Test Equipment for Apparatus Maintenance

- a. All items listed in Sections 8 and 9.
- b. Signal Generator

Output Voltage: up to 8 volts
Frequency Range: 20-kc to 230-kc
- c. Oscilloscope
- d. Ohmmeter
- e. Capacitor checker
- f. Test harness (See Fig. 17)

TABLE 1

D-C PIN JACK MEASUREMENTS WITH REFERENCE TO B-

Description	Jack	CONDITION A Tx-Blocked †† Rx-No Signal		CONDITION B Tx-Blocked Rx-With Signal		CONDITION C Tx-Unblocked Rx-No Signal	
		129 VDC	51 VDC	129 VDC	51 VDC	129 VDC	51 VDC
RF Input	J-2	0	0	0.3 V	0.3 V		
DC Q-1 Base	J-3	20 V	20 V	20 V	20 V		
DC R _x B+	J-4	20 V	20 V	20 V	20 V		
DC R _x Osc	J-5	7 V	7 V	7 V	7 V		
DC Q-5 Base	J-6	20 V	20 V	20 V	20 V		
B-	J-7						
DC-P1-E	J-8	110 V	32 V	110 V	32 V	110 V	32 V
DC-Q-7 Base	J-9	69 V	0 V	78 V	2.3 V	66 V	0.3 V
DC Q-7 Emit	J-10	70 V	1.0 V	78 V	1.4 V	66 V	1.0 V
DC T _x Osc	J-11	7 V	7 V	7 V	7 V	7 V	7 V
B+	J-12	129 V	51 V	129 V	51 V	129 V	51 V
DC Q-10 Base	J-13					18 V	18 V
DC Q-10 Emit	J-14					18 V	18 V
RF ma out	J-15					130 ma	130 ma
DC ma RRH and ALARM				18 ma	13 ma†		

† With 2000 ohm resistor and Sigma relay.

†† Tx = transmitter, Rx = receiver

TABLE 2

TYPICAL TRANSISTOR DC MEASUREMENTS WITH REFERENCE TO B-

Transistor	Condition A Tx-Blocked Rx-No Signal (Volts)			Condition B Tx-Blocked Rx-With Signal (Volts)			Condition C Tx-Unblocked Rx-No Signal (Volts)		
	E†	B†	C†	E†	B†	C†	E†	B†	C†
Q-1	20.0	20.0	0.38	20.0	20.0	0.4			
Q-2	7	7.2	1.8	7	7.2	1.8			
Q-3	6.2	8.0	2	6.2	8	2.0			
Q-4	20.0	20.0	2.6	20.0	20.0	2.8			
Q-5	20.0	20.0	2.6	20.0	20.0	2.8			
Q-6									
129 VDC	110	110	129	115	114	129			
51 VDC	32	32	51	32	32	51			
Q-7									
129 VDC	70	68	129	78	80	86			
51 VDC	1.0	0	51	1.4	2.2	7.0			
Q-8	6.2	8	2	6.2	8	2	6.2	8	2
Q-9	7	7.2	1.8	7	7.2	1.8	7	7.2	1.8
Q-10††							18	18	0.4
Q-12††							0.27	0.20	50
Q-15††							0.27	0.20	50

† E-Emitter; B-Base; C-Collector.

†† With respect to term F on printed board.

TABLE 3

D-C BLEEDER MEASUREMENTS WITH REFERENCE TO B-

Measurement	129 VDC			51 VDC		
	A†	B†	C†	A†	B†	C†
Junction R-61 and R-62 (J-8)	110V	110V	110V	32V	32V	32V
Junction R-61 and R-27 (J-10)	70V	78V	66V	1.0V	1.4V	1.0V
Junction R-27 and R-60 (P1-P)	69V	77V	65V	0	0	0
Junction CR-8 and R-64 (P1-K)	58V	58V	58V	51V	51V	51V
Junction R-48 and R-47 (J-14)	—	—	18V	—	—	18V
Junction R-45 and R-47 (TP-9)	—	—	45V	—	—	51V
Junction R-45 and R-41 (TP-8)	—	—	98V	—	—	51V

†Conditions: A — Tx-Blocked, Rx-No Signal; B — Tx-Blocked, Rx-With Signal; C — Tx-Unblocked, Rx-No Signal.

TABLE 4
TYPICAL RF SIGNAL MEASUREMENTS FOR RECEIVER
(Made with 0.1 Volt at Terminal 5 of FL1)

Check Point	25 MV Sensitivity (Volts)	80 MV Sensitivity (Volts)	250 MV Sensitivity (Volts)
With Receiver Crystal Out			
FL1-5 to Gnd.	0.1	0.1	0.1
T1-1 to Gnd.	0.1	0.1	0.1
Q1-E to Gnd.	0.05	0.05	0.05
Q1-C to Gnd.	0.07	0.07	0.07
T3-1 to Gnd.	0.07	0.07	0.07
Q4-C to Gnd.	0.07	0.07	0.07
With Receiver Crystal In			
Q4-C to Gnd.	0.5	0.5	0.25
J6 to Gnd.	0.15	0.1	0.08
Q5-C to Gnd.	7.0	1.7	0.8
Q6-B to Gnd.	2.0	0.5	0.4
Q6-C to Gnd.	13.0	10.0	8.0
T4-1 to Gnd.	13.0	10.0	8.0
T4-3 to T4-4	4.5	3.5	2.5
J9 to J10 (DC)	0.74	0.75	0.65

TABLE 5

TYPICAL RF SIGNAL MEASUREMENTS FOR TRANSMITTER

CHECK POINT	VOLTS
T5-1 to Gnd.	5.5
T5-3 to Gnd.	1.0
J13 to Gnd.	0.085
Q10-C to Gnd.	6.0
T6-2 to Gnd.	6.0
Q12-B to Gnd.	0.8
Q15-B to Gnd.	0.8
Q12-C to Gnd.	38.0
Q15-C to Gnd.	38.0
T7-5 to Gnd.	9.8
Output to Gnd.	8.0

APPLICATION

1. Receiver Selectivity (Fig. 14)

This shows a typical curve of the overall selectivity of the receiver under steady state conditions.

2. Transmitter Output Selectivity (Fig. 10)

Typical curves are shown so that approximate bandwidths for keying purposes can be determined for any carrier frequency between 30-kc and 200-kc.

3. Minimum Channel Spacing (Fig. 16)

This is a graph from which minimum channel spacing can be obtained provided the signal strength of the interfering transmitter and the sensitivity setting of the receiver are known. These can be obtained from calculations or by measurements.

For example, if the interfering transmitter voltage is measured (at the receiver) and found to be 2.5

volts, this would be 10-db down from 8 volts. This point can be located on the right hand column of the graph. Then, if the receiver sensitivity were set to operate on 0.8 volts or 20-db, this point would be located on the left hand column. A line could then be drawn through the two points as shown by the dotted line. The intersection of this line with the center line indicates the minimum channel spacing. In this case if the interfering signal is being keyed on-off, at 15 pps, the minimum spacing would be 2.5-kc.

4. Transmitter Output and Receiver Sensitivity Variations with Voltage (Fig. 12)

These curves show the variation of transmitter output and receiver sensitivity with changes in supply voltage, at 120-kc and 25°C. The increase and decrease in transmitter output above or below 1.0 watts may be obtained in db from the transmitter curve. 1.0 watts is about 8.0 volts with a 60-ohm load.

The increase and decrease in receiver sensitivity above or below 40 millivolts can similarly be

TYPE KR CARRIER SET

obtained in db from the receiver curve. 40 millivolts sensitivity represents the input signal required for proper operation.

5. Transmitter Output and Receiver Sensitivity Variations with Frequency (Fig. 13)

These curves show the variation of transmitter output and receiver sensitivity with variation in frequency, at a supply voltage of 129 VDC, and 25°C. They may be used in the same manner as Fig. 12.

6. Supervisory Control Connections (Fig. 7)

When supervisory control is used with relaying, the supervisory control relay coil is connected in

series with the RRH coil in place of the alarm relay. When supervisory control is used alone, a 2000-ohm 5-watt resistor is to be connected in series with the control relay coil. In order to maintain proper mark space ratio, the relay bias current is adjusted for 9 milliamperes as indicated.

7. Receiver Filter Limits (Fig. 15)

The receiver RF filter and the IF filter limits are shown on Fig. 15. Both filters are of the plug-in type and the test circuits with pin connections are shown at the top of each curve. The IF filter is divided into two separate sections. The selectivity shown is for each section, and the pin connections for each section are also shown in the test circuit sketch.

ELECTRICAL PARTS LIST

CIRCUIT SYMBOL	FUNCTION	DESCRIPTION	MFR. CODE	MANUFACTURER'S DESIGNATION
<u>CAPACITORS</u>				
C-1	Rcvr. Bleeder	2.0 μ f, \pm 20%, 200 VDC, Paper	1	330C567 H11
†C-2	Rcvr. Osc. Feedback	140/270 μ f, \pm 20%, 500 VDC, Mica	1	330C566 H43 or 330C566 H57
C-3	Rcvr. Osc. Bleeder Bypass	0.02 μ f, MRC, 600 VDC, Disc	1	330C569 H47
C-5	Q-6 Emitter Bypass	1.0 μ f, \pm 20%, 200 VDC Paper	1	330C567 H09
C-6	Rcvr. Rectifier Bypass	Same as C-5		
C-7	B- to B+ Bypass	2 μ f, \pm 10%, 600 VDC, Paper	1	330C573 H07
C-8	B- to GND	1.0 μ f, \pm 10%, 1000 VDC, Paper	1	330C573 H21
†C-9	Xmtr. Osc. Feedback	Same as C-2		
C-10	Xmtr. Osc.	Same as C-3		
C-11	Key Filter	0.1 μ f, \pm 20%, 200 VDC, Paper	1	330C567 H02
C-12	Q-10 Emitter Bypass	0.25 μ f, \pm 20%, 200 VDC, Paper	1	330C567 H05
C-13	Q-10 Bleeder Bypass	Same as C-12		
C-14	PA Base Bypass	Same as C-12		

†Note: 140 μ f for osc. freq. 110-kc and above.
270 μ f for osc. freq. below 110-kc.

ELECTRICAL PARTS LIST

CIRCUIT SYMBOL	FUNCTION	DESCRIPTION	MFR. CODE	MANUFACTURER'S DESIGNATION
<u>CAPACITORS (Concluded)</u>				
C-18	PA Bleeder	0.5 μ f, \pm 20%, Paper	1	330C567 H06
C-19	Output Filter Tuning	500 μ f, Variable, Air	1	328C092 H01
C-20	Output Filter	390 μ f, \pm 5%, 2500 VDC, Mica	1	330C561 H15
C-21	Output Filter	680 μ f, \pm 5%, 2500 VDC, Mica	1	330C561 H21
C-22	Output Filter	1200 μ f, \pm 5%, 2500 VDC, Mica	1	330C561 H27
C-24	FL-2 Decoupling	Same as C-12		
C-25	Q-7 Emitter	2.0 mfd, \pm 20%, 200 VDC	1	330C567 H01
<u>CRYSTAL DIODES</u>				
CR-1	Bridge Rectifier	General Purpose, IN63	1	584C433 H02
CR-2	Bridge Rectifier	Same as CR-1		
CR-3	Bridge Rectifier	Same as CR-1		
CR-4	Bridge Rectifier	Same as CR-1		
CR-5	Q-10 Collector	Same as CR-1		
CR-6	Q-7 Collector	Same as CR-1		
CR-7	Voltage Regulator	Type 1N768,	1	584C434 H02
CR-8	Voltage Regulator	Type 1N1369	1	584C434 H05
CR-9	Q-7 Collector	Type 1N1789	1	584C434 H08

ELECTRICAL PARTS LIST

CIRCUIT SYMBOL	FUNCTION	DESCRIPTION	MFR. CODE	MANUFACTURER'S DESIGNATION
<u>FUSE HOLDERS</u>				
FH-1	B-	For Type 3AGC Fuses	1	54-B-6903 H03
GH-2	B+	Same as FH-1		
<u>FUSES</u>				
F-1	B-	3AGC 3/4 amp.	1	S#1474993
F-2	B+	Same as F-1		
<u>FILTERS</u>				
FL-1	Rcvr. RF Bandpass Freq. to be specified by customer	30-kc to 60-kc 60-kc to 110-kc 110-kc to 200-kc	1 1 1	468D339 468D340 468D341
FL-2	Rcvr. IF Bandpass	20-kc Fixed Freq.	1	468D338
<u>CONNECTORS</u>				
J-1	Printed Circuit	Printed Circuit Female Plug	1	54-B-7125 H03
J-2	RF Input	UG-185-U	1	584C292 H07
J-3	Rcvr. Osc. Output	Terminal Studs	1	330C592 H01
J-4	Rcvr. Mixer-Amp Supply	Same as J-3		
J-5	Rcvr. Osc. Supply	Same as J-3		
J-6	Q-5 Base	Same as J-3		
J-7	B-	Same as J-3		
J-8	Q-6 Supply	Same as J-3		

ELECTRICAL PARTS LIST

CIRCUIT SYMBOL	FUNCTION	DESCRIPTION	MFR. CODE	MANUFACTURER'S DESIGNATION
<u>CONNECTORS (Concluded)</u>				
J-9	Q-7 Base	Same as J-3		
J-10	Q-7 Emitter	Same as J-3		
J-11	Xmtr. Osc. Supply	Same as J-3		
J-12	B+	Same as J-3		
J-13	Xmtr. Osc. Output	Same as J-3		
J-14	Q-10 Supply	Same as J-3		
J-15	Output Filter	Banana Tip Red	1	328C093 H01
J-16	Output Filter GND	Banana Tip Black	1	328C093 H02
P-1	Printed Circuit	Printed Circuit Male Plug	1	54-B-7126 H03
<u>INDUCTORS</u>				
L-1	Core and Coil Assembly	11 MH Total - 6 MH Tap (Part of FL-3)	1	329C450
L-2	Core and Coil Assembly	2.5 MH (Part of FL-3)	1	329C449
L-3	RF Choke	1.0 MH, 300 ma	2	R-300
L-4	RF Choke	Same as L-3		
<u>TRANSISTORS</u>				
Q-1	Rcvr. Mixer	Type 2N43 or Type 2N525	1	330C587 H07
Q-2	Rcvr. Osc.	Type 2N414	1	330C587 H09

ELECTRICAL PARTS LIST

CIRCUIT SYMBOL	FUNCTION	DESCRIPTION	MFR. CODE	MANUFACTURER'S DESIGNATION
<u>TRANSISTORS (Concluded)</u>				
Q-3	Rcvr. Osc.	Same as Q-2		
Q-4	Rcvr. IF	Same as Q-1		
Q-5	Rcvr. IF	Same as Q-1		
Q-6	Rcvr. IF	Type 2N332, or 2N1149	1	330C587 H04
Q-7	Rcvr. Output	Type 2N1156	1	330C587 H01
Q-8	Xmtr. Osc.	Same as Q-2		
Q-9	Xmtr. Osc.	Same as Q-2		
Q-10	Xmtr. Amp.	Same as Q-1		
Q-12	Xmtr. PA	Type 2N498	1	330C587 H12
Q-15	Xmtr. PA	Same as Q-12		
<u>RESISTORS</u>				
R-1	Rec. Input	25 K, $\pm 20\%$, 1/4 W, Pot.	1	584C276 H23
R-2	Filter Matching	10 K, $\pm 10\%$, 1/2 W	1	330C595 H37
R-3	Filter Load	Same as R-2		
R-4	Rcvr. Osc.	1 K, $\pm 20\%$, 1/4 W, Pot.	1	584C276 H19
R-5	Rcvr. Voltage Divider	6.2 K, $\pm 5\%$, 1 W	1	330C666 H68
R-6	Q-2 Collector	1.2 K, $\pm 5\%$, 1/2 W	1	330C664 H51
R-8	Rcvr. Voltage Divider	30 K, $\pm 5\%$, 2 W	1	330C668 H84
R-9	Rcvr. Voltage Divider	Same as R-8		

ELECTRICAL PARTS LIST

CIRCUIT SYMBOL	FUNCTION	DESCRIPTION	MFR. CODE	MANUFACTURER'S DESIGNATION
		<u>RESISTORS (Continued)</u>		
R-10	Q-2 Base	Same as R-2		
R-11	Q-2 Base	100 K, $\pm 10\%$, 1/2 W	1	330C595 H49
R-12	Q-3 Collector	Same as R-6		
R-13	Q-3 Emitter	390 Ohms, $\pm 5\%$, 1/2 W	1	330C664 H39
R-14	Q-3 Base	Same as R-2		
R-15	Q-3 Base	Same as R-11		
R-16	Rcvr. Osc. Bleeder	2.2 K, $\pm 10\%$, 1/2 W	1	330C595 H41
R-17	Rcvr. Osc. Bleeder	18 K, $\pm 10\%$, 2 W	1	330C597 H40
R-18	Rcvr. Osc.	9.1 K, $\pm 5\%$, 1/2 W	1	330C664 H74
R-19	Q-4 Bias	100 Ohms, $\pm 10\%$, 1/2 W	1	330C595 H13
R-20	Q-4 Bias	Same as R-2		
R-21	Q-5 Bias	150 Ohms, $\pm 10\%$, 1/2 W	1	330C595 H15
R-22	Q-5 Bias	Same as R-2		
R-23	Q-6 Bias	330 Ohms, $\pm 10\%$, 1/2 W	1	330C595 H19
R-24	Q-6 Bias	Same as R-2		
R-25	Q-6 Emitter	Same as R-19		
R-26	Q-7 Base	Same as R-6		
R-27	Q-7 Bias	20 Ohms, $\pm 5\%$, 1/2 W	1	330C664 H08
R-28	Xmtr. Osc. Bleeder	Same as R-18		
R-29	Xmtr. Osc. Bleeder	Same as R-17		
R-30	Xmtr. Osc. Bleeder	Same as R-16		

ELECTRICAL PARTS LIST

CIRCUIT SYMBOL	FUNCTION	DESCRIPTION	MFR. CODE	MANUFACTURER'S DESIGNATION
		<u>RESISTORS (Continued)</u>		
R-31	Q-8 Base	Same as R-11		
R-32	Q-8 Base	Same as R-2		
R-33	Q-8 Emitter	Same as R-13		
R-34	Q-8 Collector	Same as R-6		
R-35	Q-9 Base	Same as R-11		
R-36	Q-9 Base	Same as R-2		
R-37	Q-9 Collector	Same as R-6		
R-38	Key Filter	Same as R-23		
R-39	Buffer Voltage Divider	36 K, $\pm 5\%$, 2 W	1	330C668 H86
R-40	Buffer Voltage Divider	Same as R-39		
R-41	Buffer Voltage Divider	Same as R-2		
R-42	Xmtr. Osc. Output	Same as R-4		
R-43	Q-10 Bias	Same as R-23		
R-44	Q-10 Bias	33 K, $\pm 10\%$, 1/2 W	1	330C595 H43
R-45	Buffer Voltage Divider	15 K, $\pm 5\%$, 1 W	1	330C666 H77
R-47	Buffer Voltage Divider	6.8 K, $\pm 5\%$, 1/2 W	1	330C664 H69
R-48	Buffer Voltage Divider	Same as R-45		
R-49	PA Bias	27 K, $\pm 5\%$, 2 W	1	330C668 H83

ELECTRICAL PARTS LIST

CIRCUIT SYMBOL	FUNCTION	DESCRIPTION	MFR. CODE	MANUFACTURER'S DESIGNATION
		<u>RESISTORS (Concluded)</u>		
R-50	Xmtr. PA	Same as R-19		
R-52	Q-12 Emitter	10 Ohms, $\pm 10\%$, 1/2 W	1	330C595 H01
R-55	Q-15 Emitter	Same as R-52		
R-59	Xmtr. Bleeder	47 Ohms, $\pm 10\%$, 1/2 W	1	330C595 H09
R-60	Recvr. Bleeder	1 K, $\pm 5\%$, 25 W	1	584C416 H62
R-61	Recvr. Bleeder	600 Ohms, $\pm 5\%$, 25 W	1	584C416 H47
R-62	Recvr. Bleeder	350 Ohms, $\pm 5\%$, 25 W	1	584C416 H52
R-64	Xmtr. Bleeder	1200 Ohms, $\pm 5\%$, 25 W	1	584C416 H64
R-66	T-7 Load	560 Ohms, $\pm 5\%$, 2 W	1	330C668 H43
R-67	Xmtr. Blocking	10 Ohms, $\pm 10\%$, 2 W	1	330C668 H01
R-68	Xmtr. Blocking	10 K, $\pm 10\%$, 10 W	1	330C577 H01
R-69	Q-10 Emitter	Same as R-19		
R-70	FL2 Decoupling	470 Ohms, $\pm 10\%$, 1/2 W	1	330C595 H21
R-71	Q-4 Emitter	150 Ohms, $\pm 10\%$, 1/2 W	1	330C595 H15
R-72	Q-5 Emitter	68 Ohms, $\pm 10\%$, 1/2 W	1	330C595 H11
R-73	Q-5 Base	180 Ohms, $\pm 10\%$, 1/2 W	1	330C595 H16
R-74	Q-4 Base	2.7 K, $\pm 5\%$, 1/2 W	1	330C664 H59
R-75	Q-4 Collector	22 K, $\pm 10\%$, 1/2 W	1	330C595 H41
R-76	Q-5 Collector	Same as R-75		

ELECTRICAL PARTS LIST

CIRCUIT SYMBOL	FUNCTION	DESCRIPTION	MFR. CODE	MANUFACTURER'S DESIGNATION
<u>TRANSFORMERS</u>				
T-1	Rcvr. Input	Impedance Ratio 10 K; 10K	1	L-633005
T-2	Rcvr. Osc.	Impedance Ratio 10 K: 400 ohms	1	L-633003
T-3	Rcvr. Mixer	Impedance Ratio 25 K: 300 ohms	1	L-592171
T-4	IF Output	Impedance Ratio 4 K: 500 ohms	1	L-592289
T-5	Xmtr. Osc.	Same as T-2		
T-6	Xmtr. Buffer	Impedance Ratio 10 K: 400 ohms CT	1	L-592170
T-7	Xmtr. Output	Impedance Ratio 1930: 60	1	L-633000
<u>TEST POINTS</u>				
TP-1	R-5	Terminal studs	1	330C592 H02
TP-2	R-8	Same as TP-1		
TP-3	R-17	Same as TP-1		
TP-4	R-18	Same as TP-1		
TP-5	R-28	Same as TP-1		
TP-6	R-39 & R-40	Same as TP-1		
TP-7	R-41	Same as TP-1		
TP-8	R-45	Same as TP-1		
TP-9	R-47	Same as TP-1		

ELECTRICAL PARTS LIST

CIRCUIT SYMBOL	FUNCTION	DESCRIPTION	MFR. CODE	MANUFACTURER'S DESIGNATION
<u>SOCKETS</u>				
X-1	FL-1	Octal	1	330C689 H01
X-2	FL-2	Same as X-1		
X-4	Rear Mounted Voice Adaptor	Same as X-1		
XY-1	Rec. Y-1	Crystal	1	50-D-9790 H01
XY-2	Xmtr. Y-2	Same as XY-1		
<u>CRYSTALS</u>				
Y-1	Rcvr. Osc.	Specify Channel Freq. Plus 20-kc	1	328C083
Y-2	Xmtr. Osc.	Specify Freq. Same as Channel Frequency	1	328C083
<u>SLEET DETECTOR</u>				
R-1	Resistor, Level Control	100 K, 2 W, Pot.	1	51-D-1976 H17 (S#1475074)
R-2	Resistor, Limiting	2000 ohms, 2" tube.	1	1267296
S-1	Switch Sleet Test	SPST Normally Open	1	327C854 H01

LIST OF MANUFACTURERS

1. Westinghouse Electric Corporation
2. National Co., Inc., Malden, Mass.

TYPE KR CARRIER SET

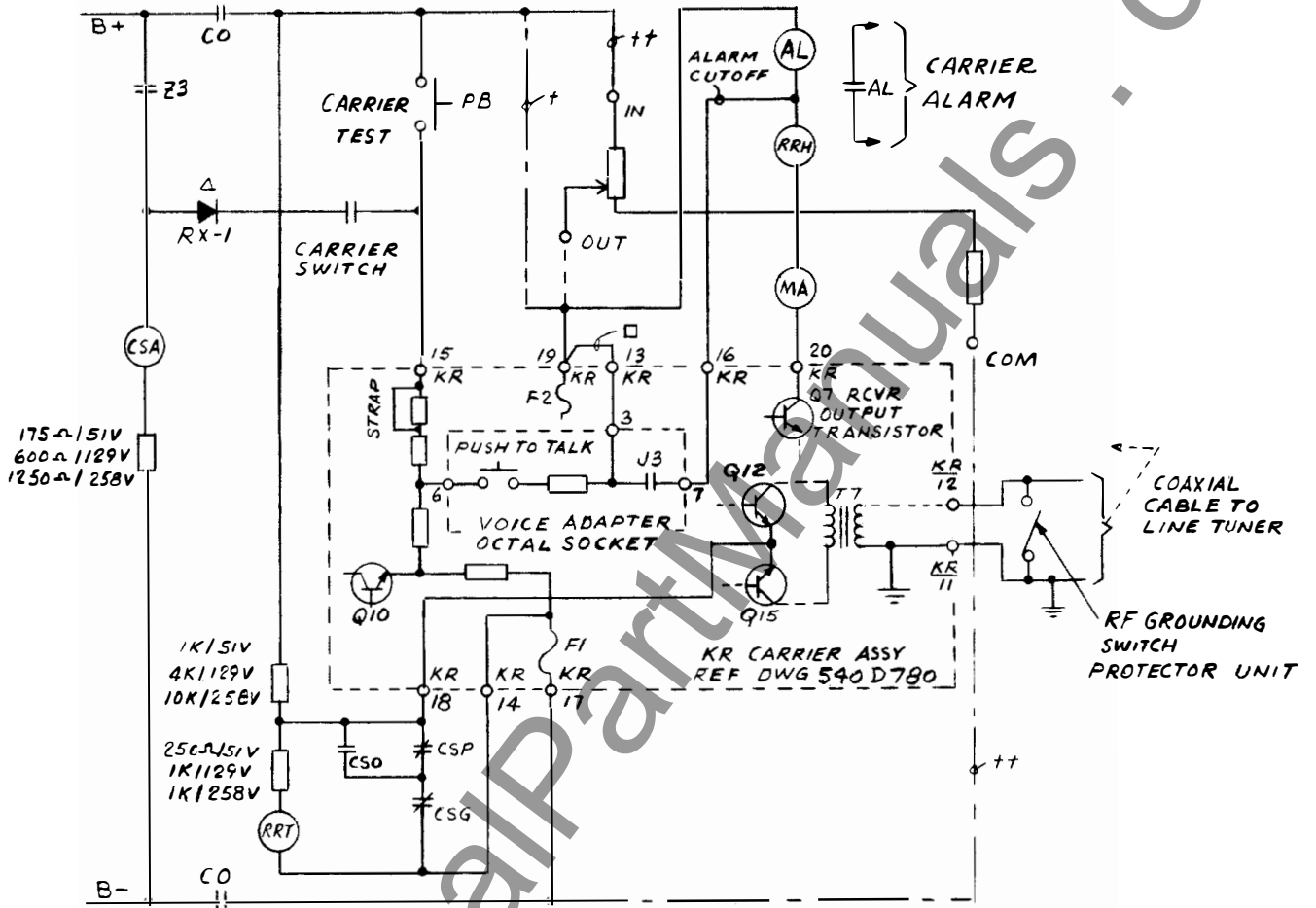

REQUIREMENTS FOR ^{HZ/HZM} RELAYING

SUPPLY VOLTAGE	CARRIER START	CARRIER STOP	STRAP
51VDC	+51V, 7MA	+28V	IN
129VDC	+129V, 8MA	+40V	IN
258VDC	+258V, 8MA	+40V	OUT

KR RELAYING TRANSMITTER /
REQ. EXTERNAL CONNECTIONS

TERMINAL - CONNECTION

- 11. GROUND
- 12. COAXIAL CABLE
- 13. SUPERVISORY PREFERENCE CONTACT
- 14. CARRIER STOP B- RETURN
- 15. CARRIER START (POSITIVE)
- 16. ALARM CUTOFF FOR COMMUNICATIONS
- 17. B MINUS
- 18. CARRIER STOP (HZ/HZM)
- 19. B PLUS
- 20. RELAY COIL

NOTES

- △ CONNECT RX-1 (DWG 22B5605 S# 1595821) AS SHOWN
- + FOR 51 & 129 VDC SUPPLY.
- ++ FOR 258 VDC SUPPLY USE 330C191H01 RESISTOR UNIT REF DWG 223B497.
- FOR SUPERVISORY CONTROL PREFERENCE CONTACTS.

Fig. 3- Relaying Control Circuits - HZ/HZM (Dwg. 1-329C704)

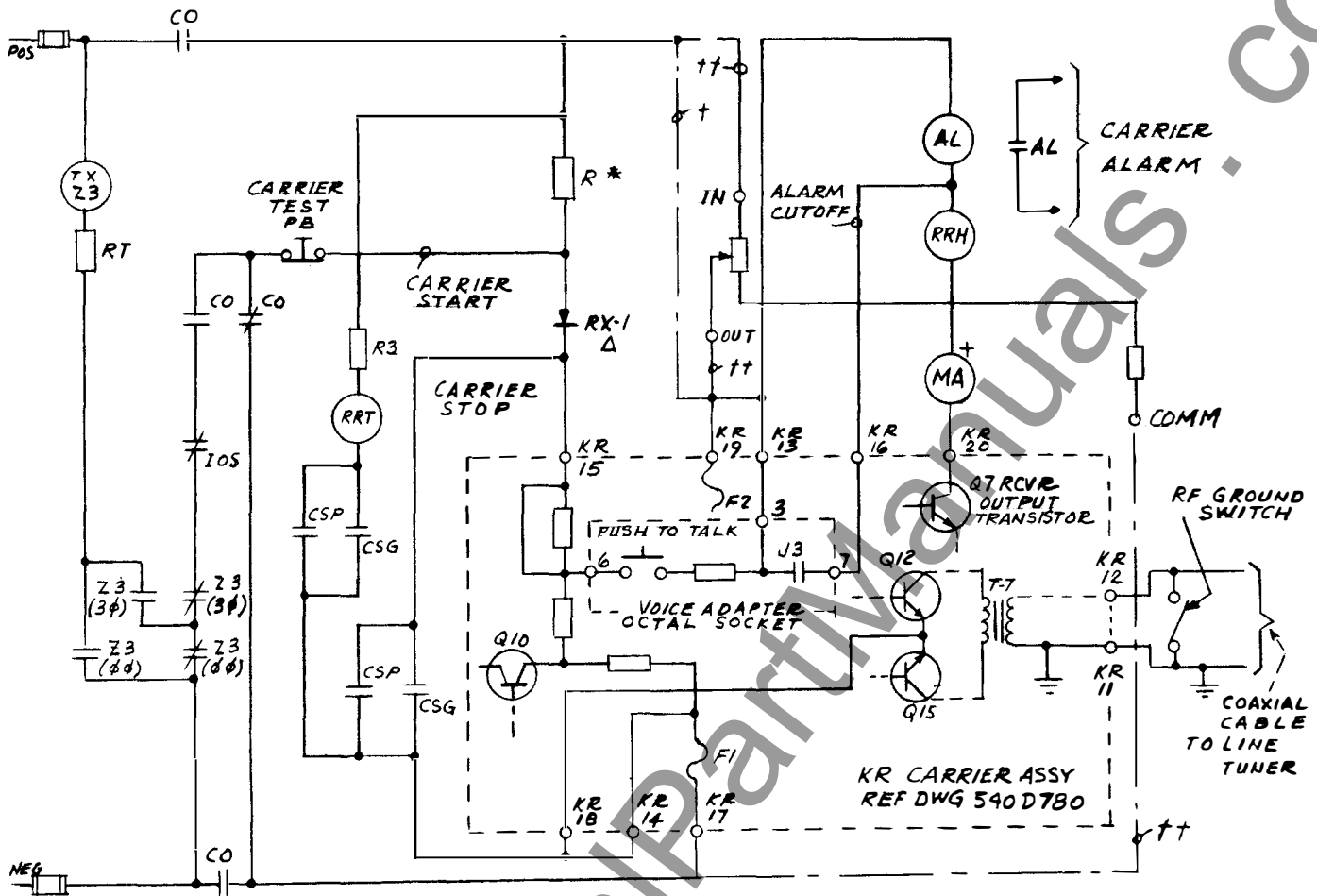

REQUIREMENTS FOR K-DAR RELAYING

SUPPLY VOLTAGE	CARRIER START	CARRIER STOP	R
51 VDC	+ 37V, 7MA	0 VOLTS	2K
129 VDC	+ 100V 8MA	0 VOLTS	3.75K
258 VDC	+ 100V 8MA	0 VOLTS	19K

KR RELAYING TRANSMITTER /
 REC.V. EXTERNAL CONNECTIONS
 TERMINAL CONNECTION

- 11 GROUND
- 12 COAXIAL CABLE
- 13 SUPERVISORY PREFERENCE CONTACT
- 14 CARRIER STOP B-RETURN
- 15 CARRIER START (POSITIVE)
- 16 ALARM CUTOFF FOR COMMUNICATIONS
- 17 B MINUS
- 18 CARRIER STOP (HZ/HZM)
- 19 B PLUS
- 20 RELAY COIL

NOTES

- * FOR "R" USE OHMITE VITREOUS ENAMELED DIVIDOHM ADJUSTABLE 4K OR 26K 25W RESISTOR. CONNECT & ADJUST FOR VALUES SHOWN
- Δ CONNECT RX-1 (DWG 22B5605 S# 1595821) AS SHOWN
- + FOR 51 & 129 VDC SUPPLY
- ++ FOR 258VDC SUPPLY USE 330C191H01 RESISTOR UNIT REF DWG 223B497

Fig. 4-Relaying Control Circuits-K-Dar (Dwg. 3-329C704)

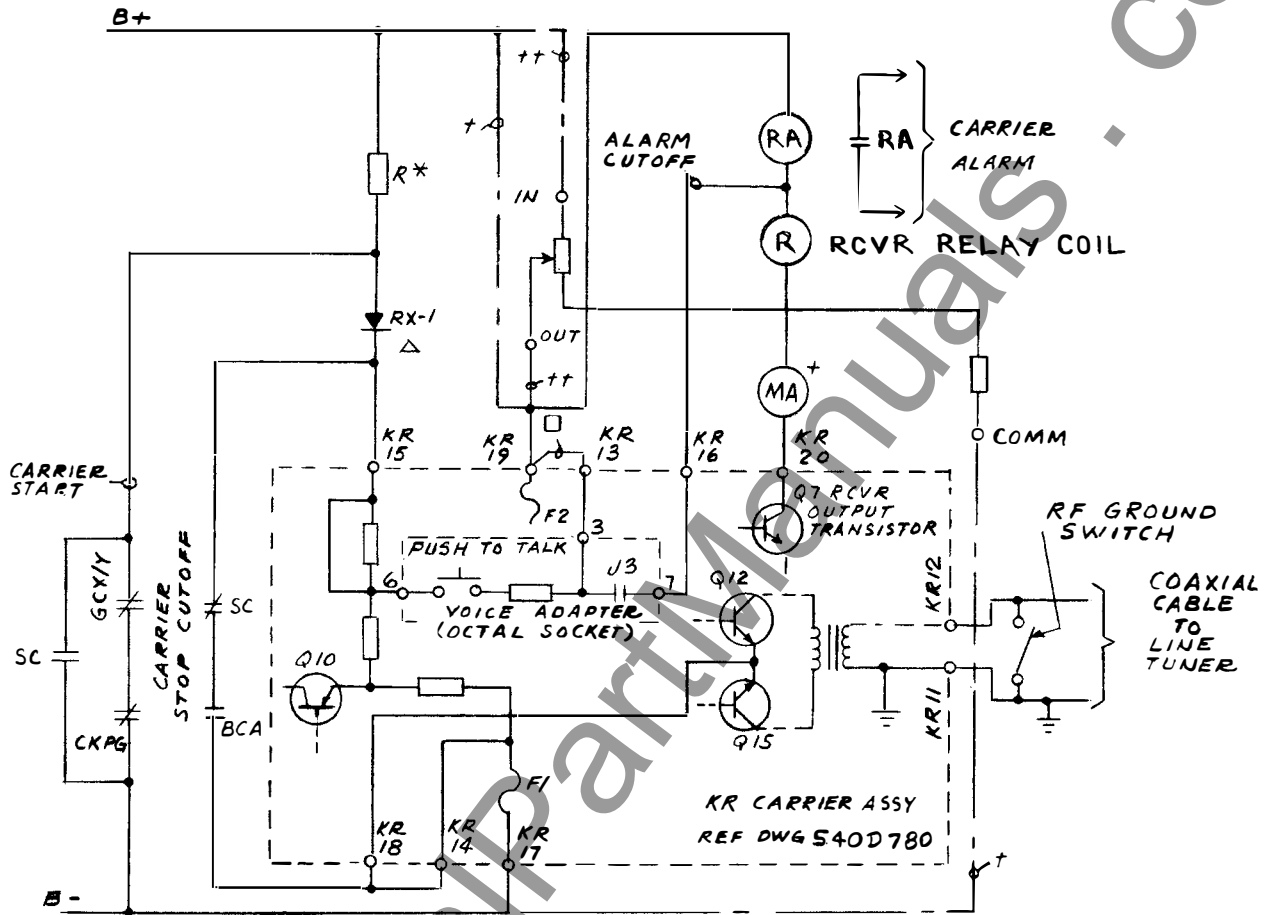

REQUIREMENTS FOR GCX/GCY RELAYING

SUPPLY VOLTAGE	CARRIER START	CARRIER STOP	R
51 VDC	+37V, 7MA	0 VOLTS	2K
129 VDC	+100V, 8MA	0 VOLTS	3.75K
258 VDC	+100V, 8MA	0 VOLTS	19.K

KR RELAYING TRANSMITTER /
RCV. EXTERNAL CONNECTIONS
TERMINAL- CONNECTION

11. GROUND
12. COAXIAL CABLE
13. SUPERVISORY PREFERENCE CONTACT
14. CARRIER STOP B- RETURN
15. CARRIER START (POSITIVE)
16. ALARM CUTOFF FOR COMMUNICATIONS
17. B MINUS
18. CARRIER STOP (HZ/HZM)
19. B PLUS
20. RELAY COIL

NOTES

- * FOR "R" USE OHMITE VITREOUS ENAMELED DIVIDOHM ADJUSTABLE 4K OR 20K 25W RESISTOR, CONNECT & ADJUST FOR VALUES SHOWN
- △ CONNECT RX-1 (SILICON RECTIFIER TYPE 352F OR EQUIVALENT) AS SHOWN
- + FOR 51 & 129 VDC SUPPLY
- ++ FOR 258VDC SUPPLY USE 330C191H01 RESISTOR UNIT REF DWG 223B497
- FOR SUPERVISORY CONTROL PREFERENCE CONTACTS

Fig. 5. Relaying Control Circuits—GCX/GCY (Dwg. 2-329C704)

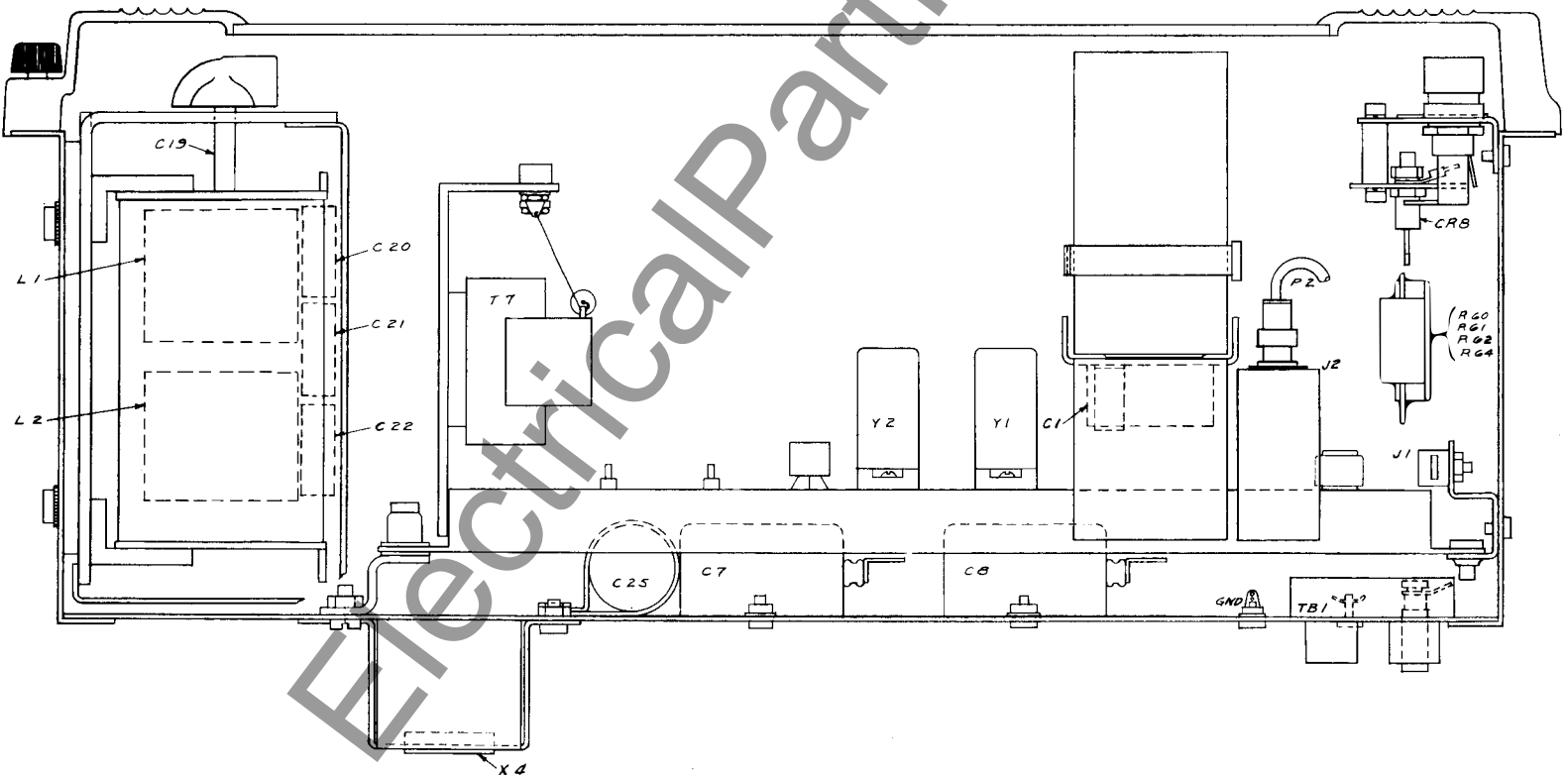
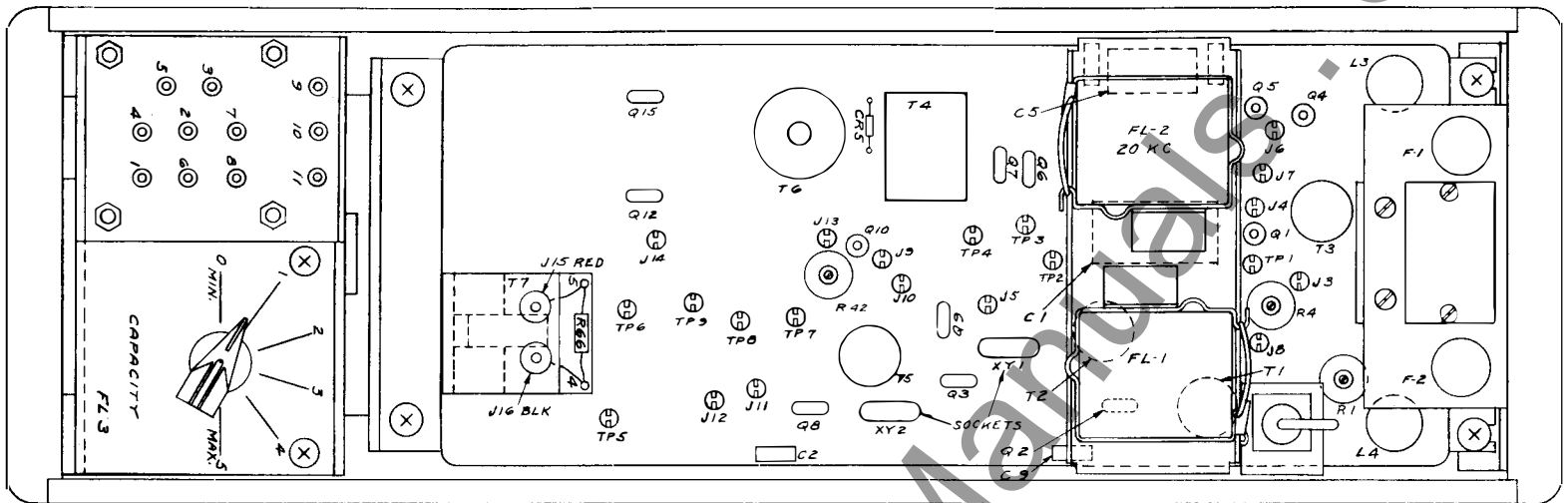

Fig. 6. Component Location (Dwg. 540D781)

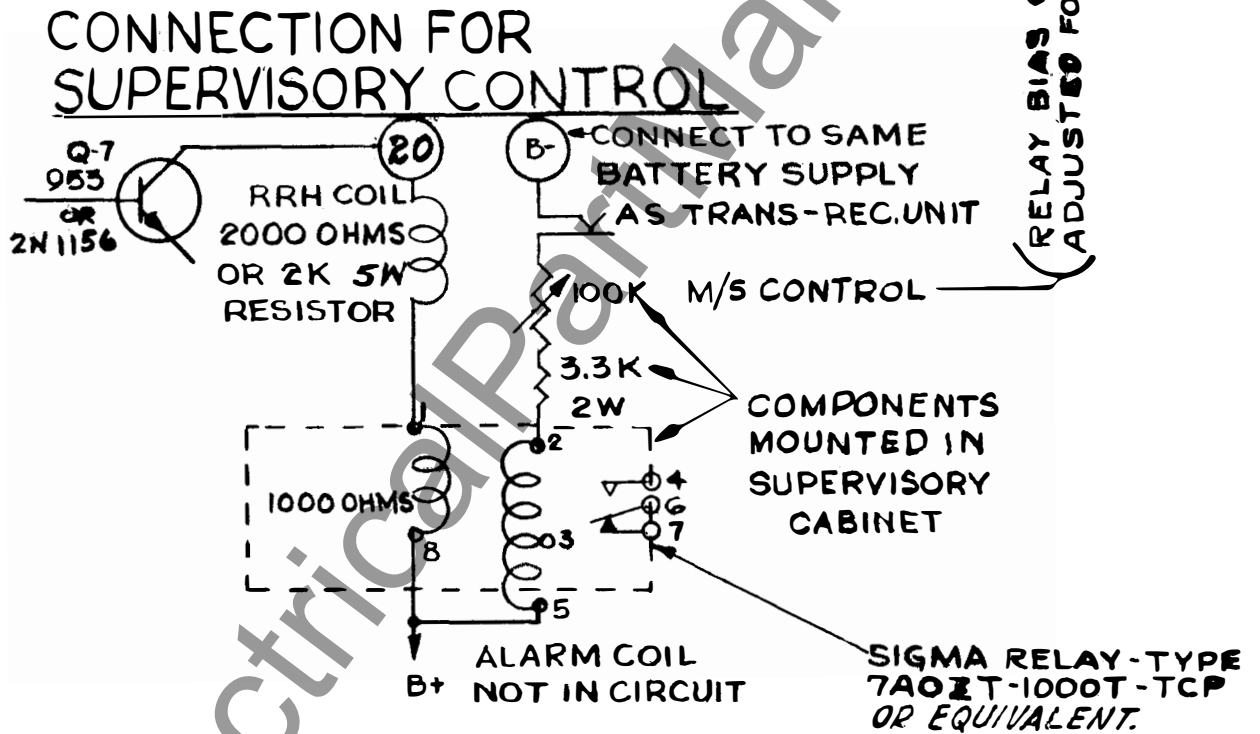

Fig. 7. Supervisory Control Connections (Dwg. 223B498)

**CONNECTIONS FOR 48-250 VOLT SERVICE AND
SUPERVISORY CONTROL APPLICATION**
(CHANGES FROM JUMPERS SHOWN ON INTERNAL SCHEMATIC, FIG.2)

250-VOLT OPERATION

FOR A 250 VOLT SUPPLY, RESISTOR UNIT 330C191H01 IS USED AS SHOWN ON APPLICATION DRAWING 329C704

FOR HZ/HZM OPERATION, THE JUMPER HAS BEEN REMOVED FROM TP-6 TO TP-7. (NOT REMOVED FOR K-DAR RELAYING).

RESISTOR UNIT SCHEMATIC:

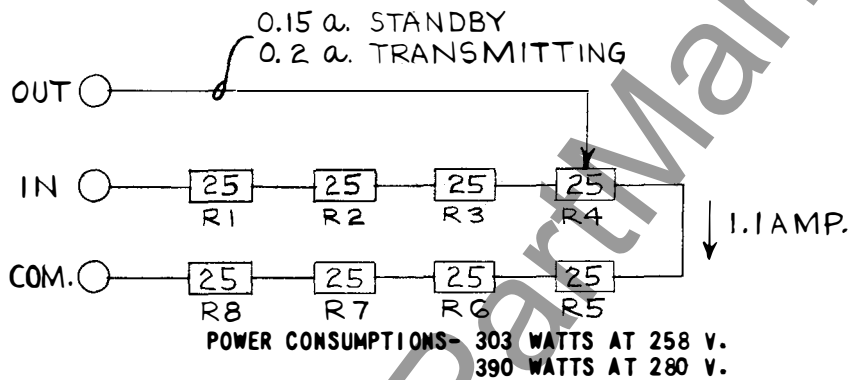

NOTE: KR SUPPLY VOLTAGE WILL BE APPROXIMATELY 144 VOLTS UNDER STANDBY CONDITION WHEN BATTERY VOLTAGE IS 280 VOLTS.

125-VOLT HZ/HZM OPERATION
JUMPER TP-7 AND TP-8 IS REMOVED.

48 VOLT OPERATION

ON PRINTED CIRCUIT BOARD ADDITIONAL JUMPERS ARE CONNECTED AS FOLLOWS:

- BETWEEN TP8 AND TP9
- BETWEEN TP5 AND J12
- BETWEEN TP1 AND TP2
- BETWEEN TP3 AND TP4

IN THE FT CASE, JUMPERS ARE CONNECTED ACROSS R60 AND R64, AND THE CONNECTION BETWEEN R64 AND DIODE CR8 IS REMOVED.

IN ADDITION, FOR 48-VOLT SUPERVISORY CONTROL, R59 IS CONNECTED INTO THE CIRCUIT.

Fig. 8. Connections, 48-250 Volts and Supervisory Control (Dwg. 407C971)

TRANSMITTER OUTPUT FILTER FL-3 CONNECTIONS

<u>LINE</u>	<u>FREQUENCY RANGE</u>	<u>COIL</u>	<u>COIL CONNECTIONS</u>	<u>PARALLEL CAPACITOR CONNECTIONS</u> Δ
1	27.7 KC-30.0 KC	L-1	(1-5) (3-6)	6-8-9-10-11
2	29.8 KC-33.1 KC	L-1	(1-5) (3-6)	6-8-10-11
3	31.8 KC-36.0 KC	L-1	(1-5) (3-6)	6-8-9-11
4	35.4 KC-39.0 KC	L-1	(1-5) (3-6)	6-8-11
5	38.0 KC-41.0 KC	L-1	(1-2) (3-6)	6-8-9-10-11
6	40.3 KC-45.0 KC	L-1	(1-2) (3-6)	6-8-10-11
7	43.0 KC-49.0 KC	L-1	(1-2) (3-6)	6-8-9-11
8	47.7 KC-56.0 KC	L-1	(1-2) (3-6)	6-8-11
9	49.5 KC-58.5 KC	L-1	(1-2) (3-6)	6-8-9-10
10	57.0 KC-72.3 KC	L-1	(1-2) (3-6)	6-8-10
11	67.0 KC-76.0 KC	L-2	(1-4) (6-7)	6-8-9-11
12	75.0 KC-88.0 KC	L-2	(1-4) (6-7)	6-8-11
13	77.5 KC-93.0 KC	L-2	(1-4) (6-7)	6-8-9-10
14	89.3 KC-114.5KC	L-2	(1-4) (6-7)	6-8-10
15	102.7KC-147.0KC	L-2	(1-4) (6-7)	6-8-9
16	136.6KC-210.0KC	L-2	(1-4) (6-7)	6-8

Δ CONNECTION FROM 6 TO 8 IS MADE BENEATH TERMINAL PLATE ON ALL SETS AT THE FACTORY.

Fig. 9. Connections - Output Filter (Dwg. 149A420)

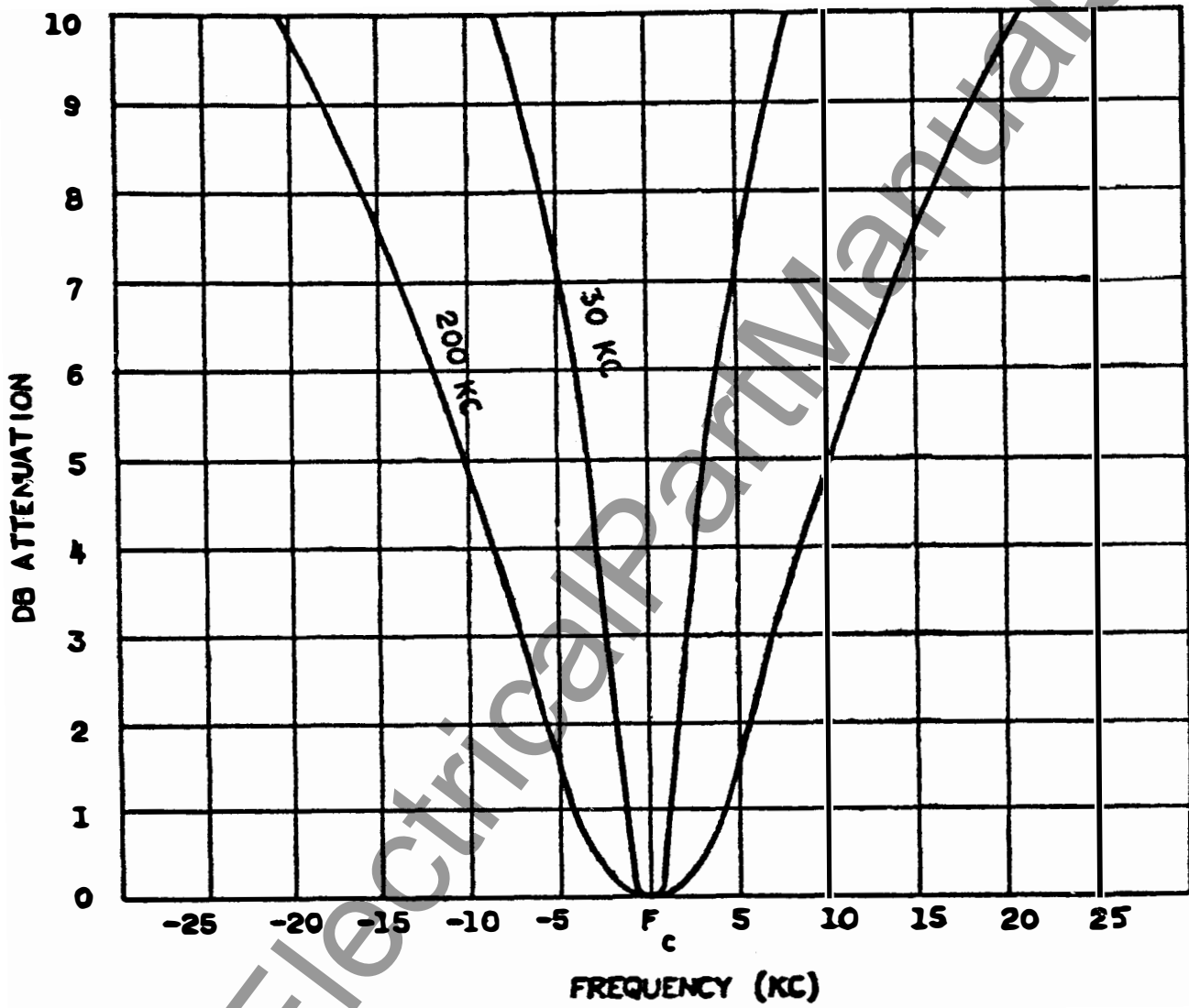

Fig. 10. Transmitter Output Filter Selectivity (Dwg. 377996)

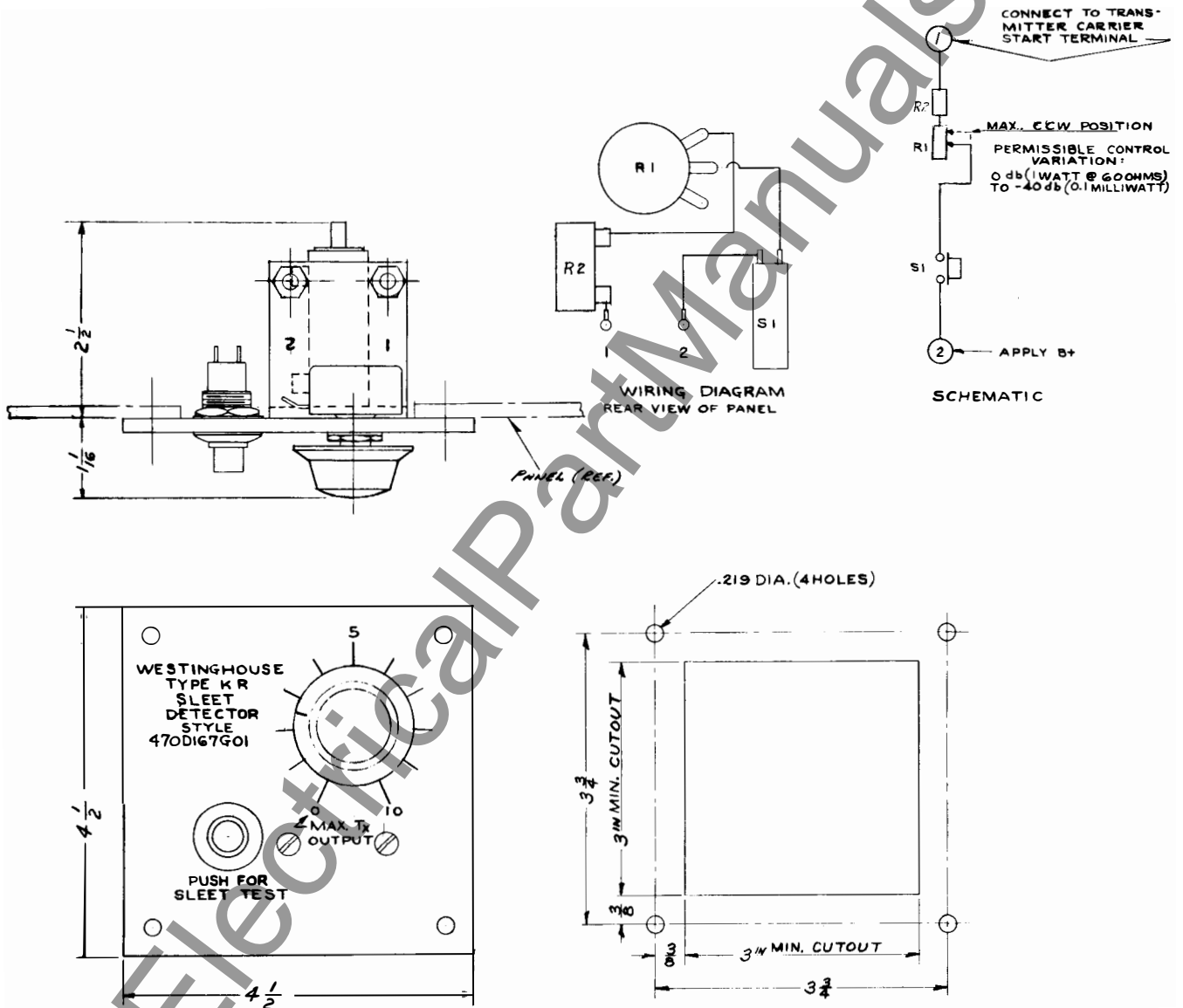

Fig. 11. Sleet Detector Outline (Dwg. 329C703)

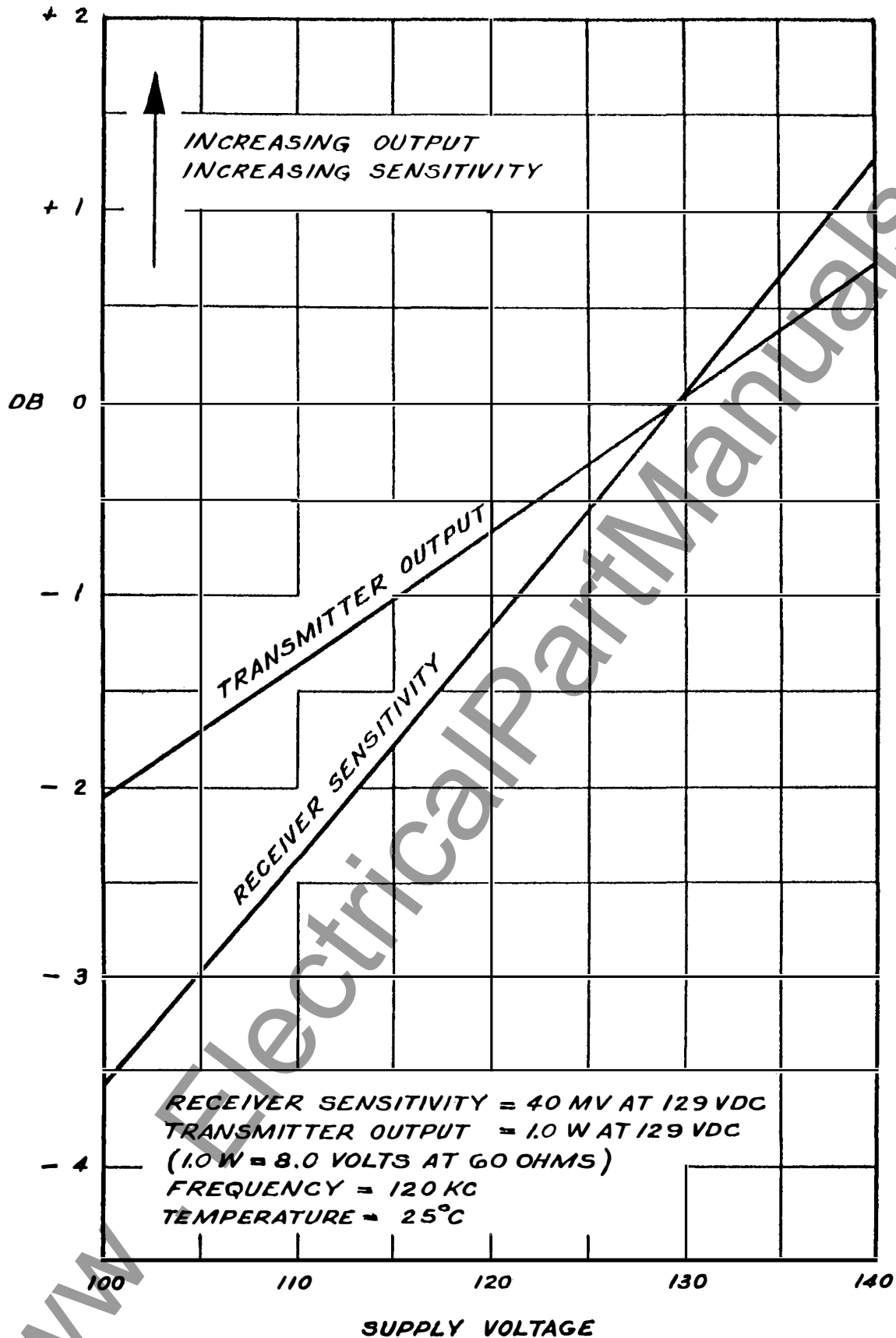

Fig. 12. Transmitter Output and Receiver Sensitivity Variations with Voltage (Dwg. 377999)

TRANSMITTER OUTPUT & RECEIVER SENSITIVITY VARIATIONS WITH FREQUENCY

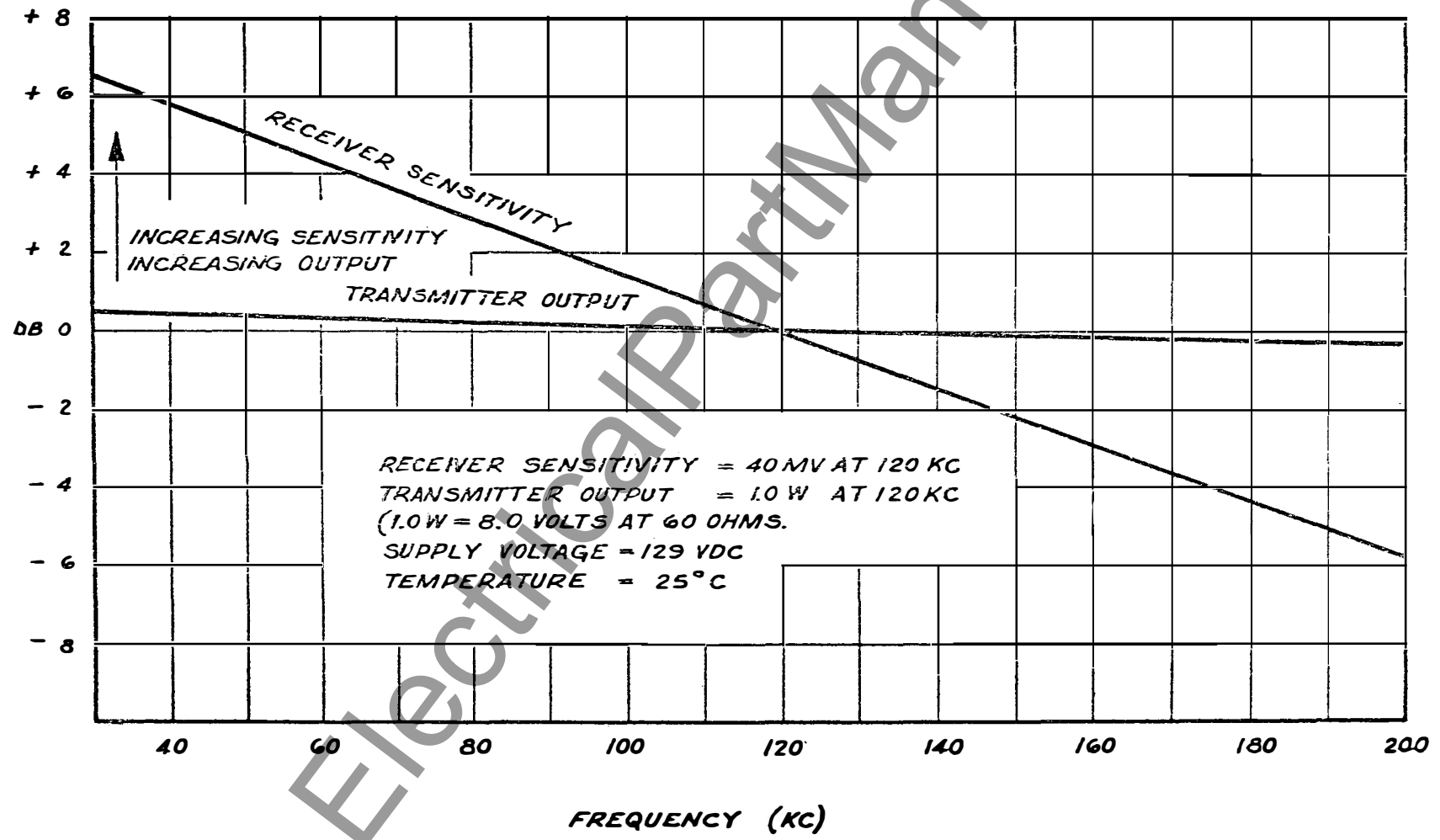

Fig. 13. Transmitter Output and Receiver Sensitivity Variations with Frequency (Dwg. 378000)

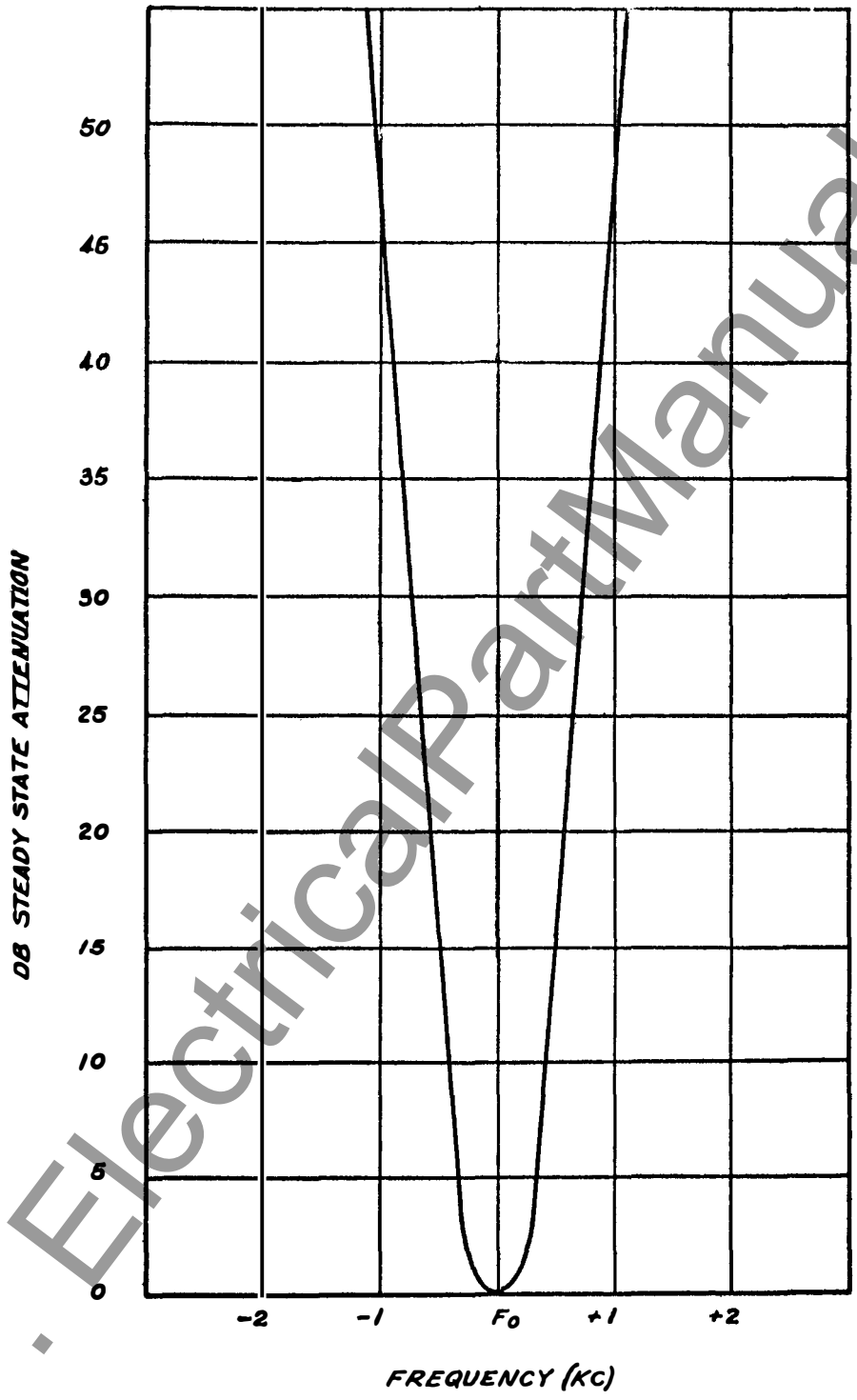
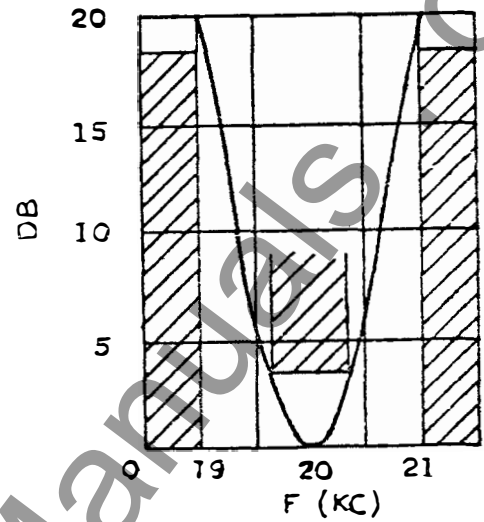
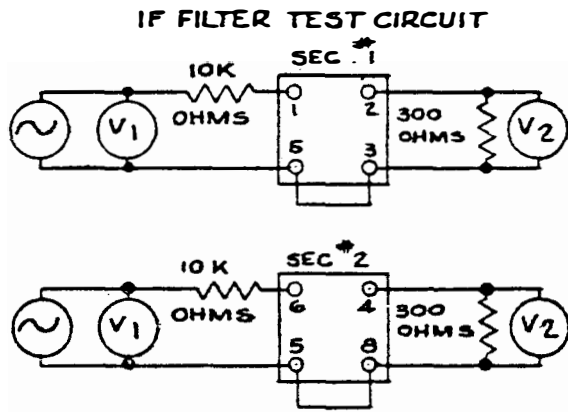
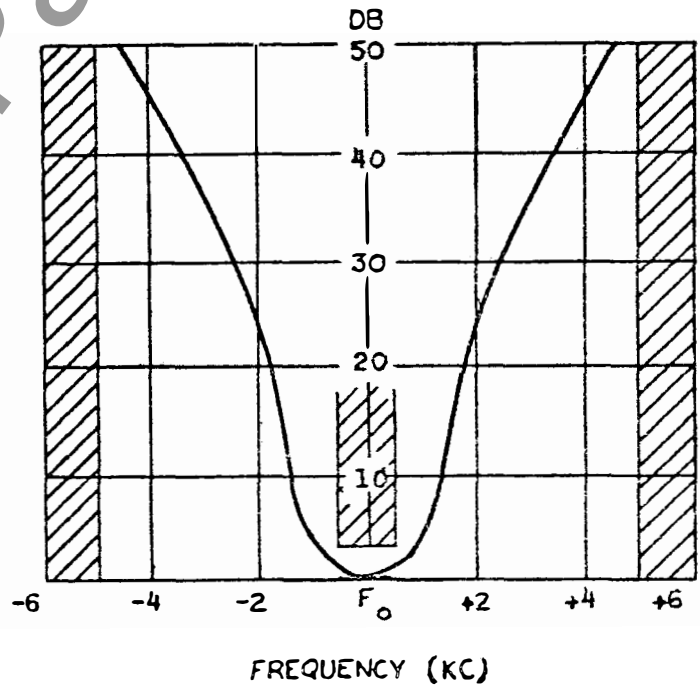
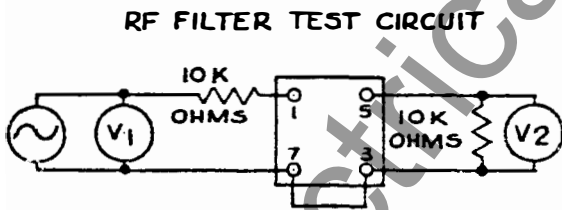

Fig. 14. Receiver Selectivity (Dwg. 377993)



Each section FL-2 requirement
with typical selectivity curve
Insertion loss 26 DB max.
Including matching resistor.



FL-1 Requirement with typical selectivity
curve at 120 KC. Insertion loss 18 DB
max. Including matching resistor.

Fig. 15. Receiver Filter Limits (Dwg. 377995)

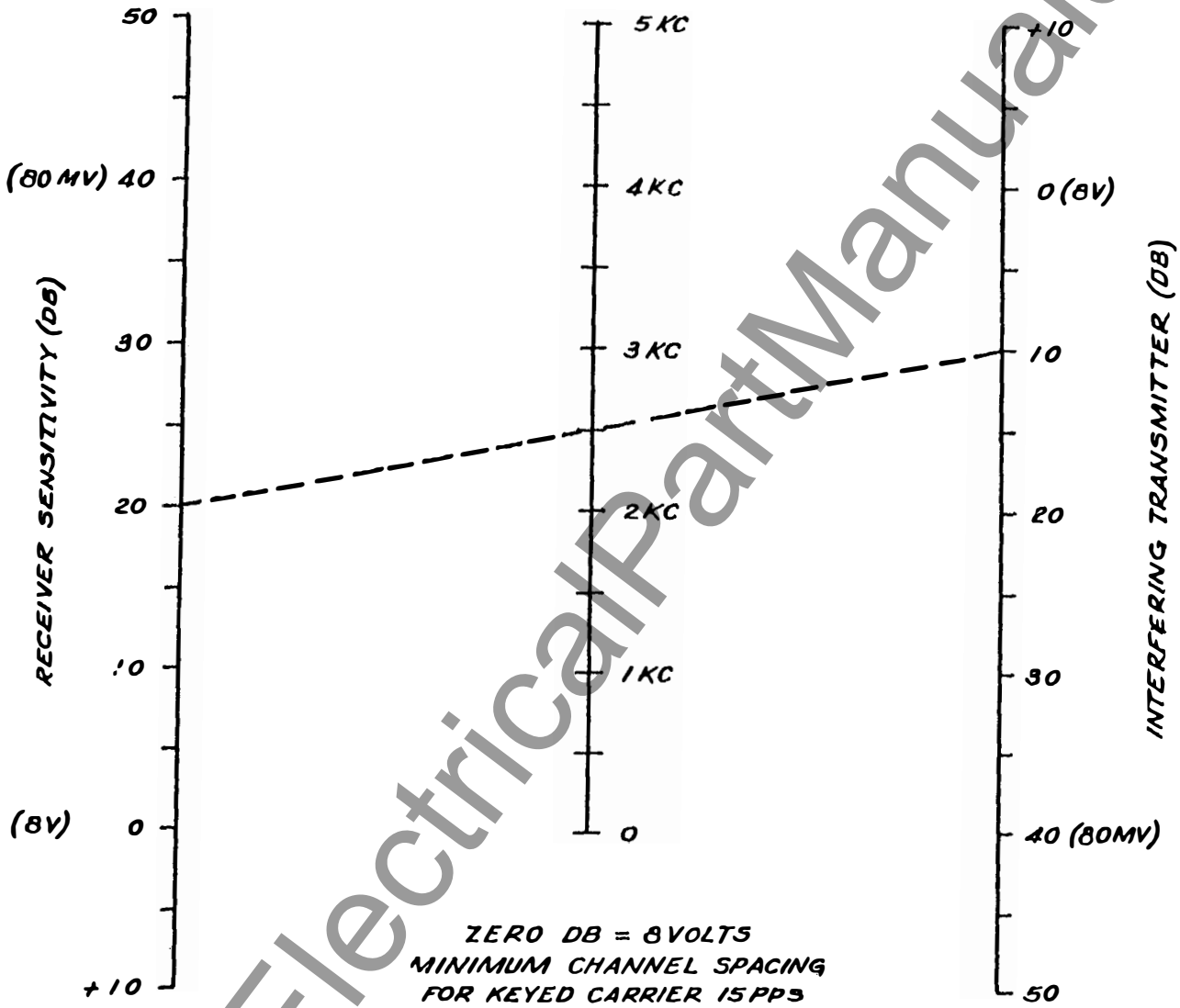
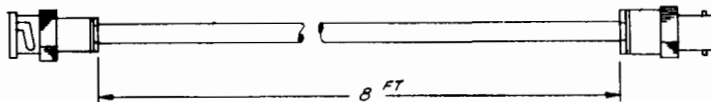
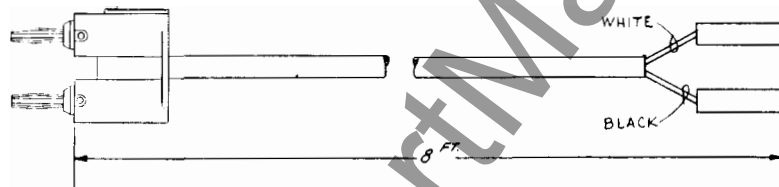

Fig. 16. Minimum Channel Spacing (Dwg. 377998)



Coaxial Lead... 756D346 G02



Output Lead... 756D346 G03

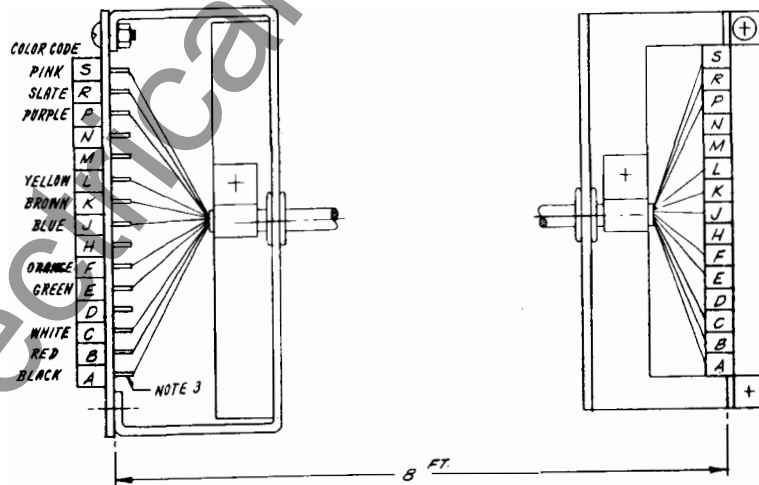

Main Harness... 756D346 G04

Fig. 17. Test Harness - (Complete Set)



WESTINGHOUSE ELECTRIC CORPORATION
RELAY-INSTRUMENT DIVISION

NEWARK, N. J.

Printed in U.S.A.