

**INSTALLATION • OPERATION • MAINTENANCE
I N S T R U C T I O N S****TYPES SC, SC-1, SV AND SV-1 RELAYS**

CAUTION Before putting protective relays into service, remove all blocking which may have been inserted for the purpose of securing the parts during shipment, make sure that all moving parts operate freely, inspect the contacts to see that they are clean and close properly, and operate the relay to check the settings and electrical connections.

APPLICATION

The types SC and SC-1 current relays and the types SV and SV-1 voltage relays are applicable where an instantaneous plunger relay of high accuracy is required. These relays are suitable for protective service, and for auxiliary service where some of their special features are desired. They are adjustable over a wide range of voltage or current, are provided with mechanical operation indicators, and have a calibrated scale which indicates the pick-up setting. Both contacts can readily be changed from "make" to "break". The volt-ampere burden is low.

The type SC and SV relays have a high ratio of drop-out to pick-up (90 to 98%) and are particularly suitable for fault detector relays. The type SC-1 and SV-1 relays have a lower ratio of drop-out to pick-up. This lower ratio may be desirable in some applications, and it makes possible a plunger pull characteristic which permits the operation of a latching device. The latch is combined with the mechanical operation indicator, and prevents further motion of the moving contacts after the relay has operated.

CONSTRUCTION

The types SC, SC-1, SV and SV-1 relays operate on the solenoid principle. A U-shaped

iron frame, mounted on the moulded base, supports the coil and serves as the external magnetic path for the coil. The coil surrounds a core and flux shunt. The upper end of the core is threaded and projects through the upper side of the frame, to which it is fastened by a nut. A tube threaded on the outside at its lower end is assembled in the core, and the threaded end extends below the core. A graphite bushing, which is the lower bearing for the plunger shaft, is assembled in the lower end of this threaded tube. It is held in place by two split spring sleeves, one above and one below the bearing. The split sleeves must be compressed to insert them in the tube and they will remain at any position in which they are placed. The bearing for the upper end of the plunger shaft is a graphite bushing which is pressed in the upper end of the core. This bearing is visible when the plunger is in the energized position. The plunger itself does not touch the walls of the tube in which it moves.

A flux shunt which surrounds the core is screwed on the tube, and its lower end projects below the relay frame. The position of this shunt determines the pick-up setting of the relay. The lower end of the shunt is beveled and knurled, so that it can be grasped by the fingers and turned to change the setting. A calibrated scale plate is mounted adjacent to the shunt. A groove just above the knurl in the lower end of the shunt serves as an index mark, and the relay pick-up setting is indicated by the calibration scale marking which is adjacent to the groove.

The construction of the plunger, core and flux shunt (which differ in details in the various types of these relays) causes the plunger to float in its energized position.

SUPERSEDES I.L. 41-766.1

*Denotes changed from superseded issue.

EFFECTIVE JANUARY 1958

TYPES SC, SC-1, SV AND SV-1 RELAYS

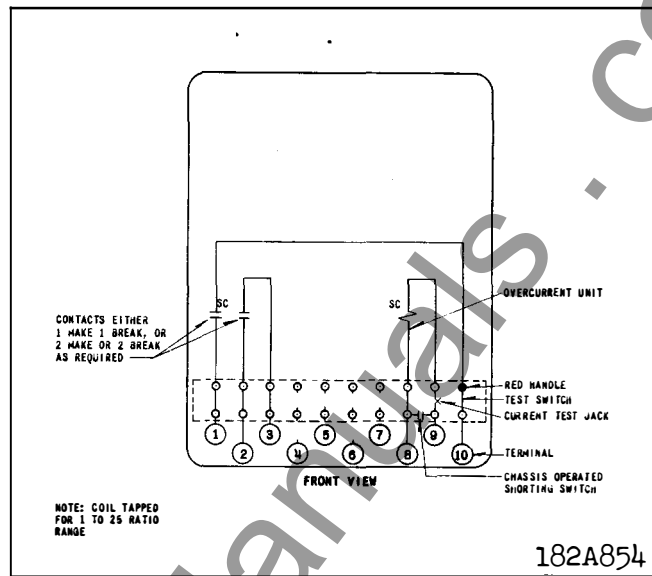
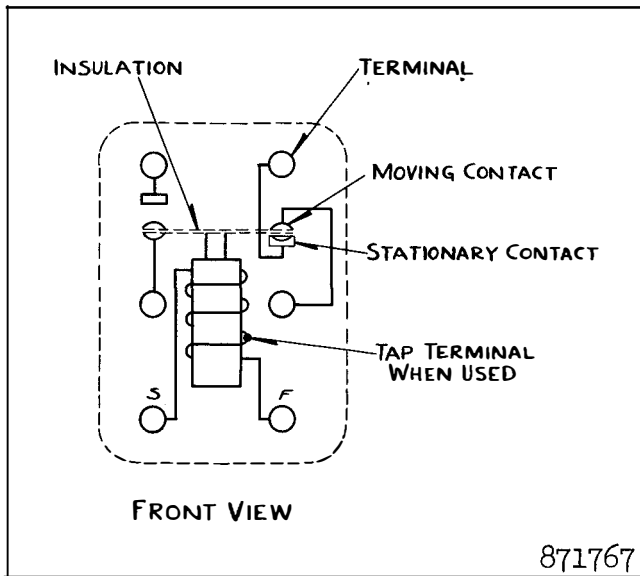

Fig. 1. Internal Wiring of the Relays In The Small Glass Case.

* Fig. 2. Internal Schematic of the Single Unit Type SC or SC-1 Relay in The Type FT21 Case.

without being held against a stop, even when energized much above the pick-up value. Consequently, there is negligible noise and the contacts are free from chatter, even on heavy overloads and in 25 cycle applications.

The core, shunt, and plunger construction also provides the high ratio of drop-out to pick-up in the SC and SV relays. This ratio is above 90% for any pick-up setting. In the latch type relays it is necessary for the plunger to rise with sufficient force to operate the latch positively and to deflect the stationary contacts sufficiently to prevent their opening, when the relay is de-energized, due to play in the latch. It is necessary to have a lower ratio of drop-out to pick-up in, order to obtain this characteristic, and this lower ratio may be desirable in some applications where the latch is not required. The plunger floats in its operated position just as in the SC and SV relays. The drop-out ratio varies somewhat for different shunt positions, but is constant for any one setting.

The shunt is held in any desired position by pressure from a curved arm made of sheet spring steel, which is fastened to the bottom

of the coil frame at the rear of the shunt. This spring arm is shaped to extend around the shunt to the front of the relay, and in its normal position it exerts sufficient pressure against the shunt to prevent any creeping of the shunt or undesired change of setting. The front end of the spring arm has a bent-over tab on which thumb-pressure may be applied to move the arm out of contact with the shunt while the position of the latter is being changed.

The stationary contacts are assembled on slotted brackets. These are held in position on the base by filister-head screws which are threaded into the terminal inserts. Lock-washers are assembled inside the moulded terminal bushings between the inserts and the base, as a safeguard against loosening of the screws. By rotating the bracket on its mounting screw and moving it along its slot, the contact assembly can be made either normally open or normally closed. The moving contacts are mounted on a Micarta insulation plate which is secured to the threaded end of the plunger shaft by a nut. The front edge of this insulation plate operates the indicator. The rear portion of the plate is slotted and a post screwed to the frame passes through this

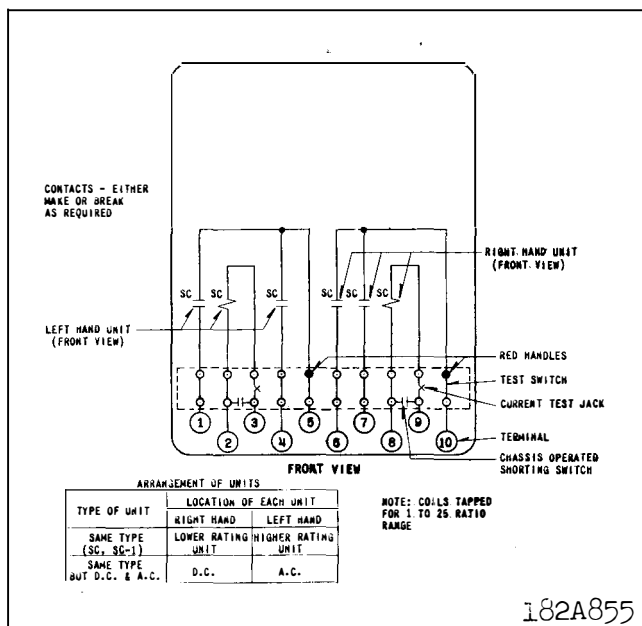

182A855

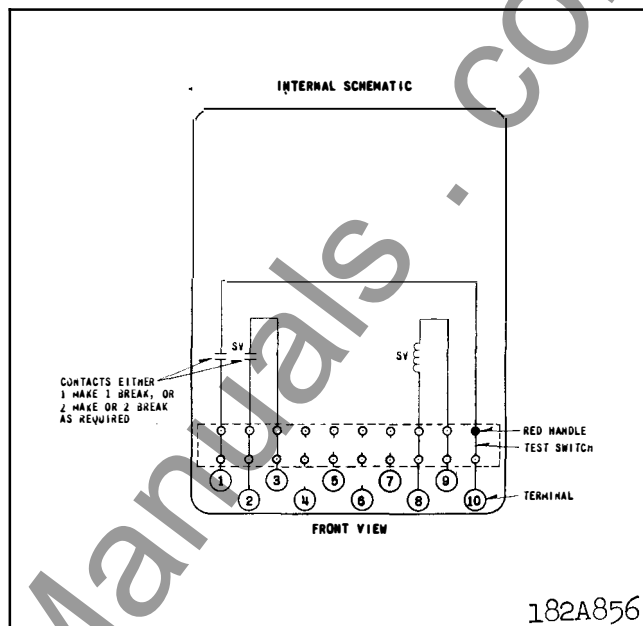

182A856

* Fig. 3. Internal Schematic of the Double Unit Type SC or SC-1 Relay in the Type FT21 Case.

Fig. 4. Internal Schematic of the Single Unit Type SV or SV-1 Relay in the Type FT21 Case.

slot to prevent the plate from rotating. The moving contacts are double-faced so that they can be "make" or "break" and are connected to the base terminals by flexible leads. All contacts are pure silver. The contacts will carry 5 amperes continuously, and will interrupt 5 amperes at 115 volts A-C, or 1 ampere at 125 volts D-C.

The mechanical operation indicators used on these relays are shockproof, and can be used to indicate on the up stroke or down stroke of the plunger. The indicator is reset by pulling out the knurled stud which projects through the cover nut. The indicator should be reset after each relay operation because otherwise there may be a one or two percent decrease in the operating value of the relay. The operation indicator is assembled at the factory to indicate on the up stroke of the plunger, but by removing the two mounting screws which fasten the indicator to the main frame, turning the indicator bracket around and at the same time swinging the indicator flag 180° about its shaft, the indicator can be set to indicate on the down stroke of the plunger. The rivet weight must be removed from the indicator flag and the latch screen

turned around to complete the assembly.

In certain applications, an extremely wide range of current adjustment is desirable, and certain styles of SC and SC-1 relays have been provided with tapped coils to meet this requirement. The coil taps are brought out to a tap block mounted on the lower end of the relay frame or on the relay sub-base, depending on the type of case used. The connector plate on the tap block is marked with the minimum pick-up value of each tap, and the shunt is adjusted in the usual manner to obtain any pick-up setting between taps. The scale plate is not calibrated for the relays with tapped coils, as there is not sufficient space for marking a scale for each tap. However, the scale plate is supplied in order that a customer may mark on it the individual relay setting or settings if desired.

INSTALLATION

The relays should be mounted on switchboard panels or their equivalent in a location free from dirt, moisture, excessive vibration, and heat. Mount the relay vertically by means of the four mounting holes on the flange for

CHARACTERISTICS OF TYPES SC AND SC-1 RELAYS

Type	Frequency	Range of Adjustment Amps.	Max. Amps. Continuous	Watts 5 Amps. 60 Cycles	V.A. at 5 Amps. 60 Cycles	Dropout Ratio-AC	Dropout Ratio-DC
SC	DC, 25 to 60 C.	.5-2	1.5	99	225	90-98%	65-80%
SC	DC, 25 to 60 C.	1-4	3	28	65	90-98%	65-80%
SC	DC, 25 to 60 C.	2-8	6	6.9	19	90-98%	65-80%
SC	DC, 25 to 60 C.	4-16	12	1.5	5	90-98%	65-80%
SC	DC, 25 to 60 C.	10-40	25	.24	.7	90-98%	65-80%
SC	DC, 25 to 60 C.	20-80	40	.07	.16	90-98%	65-80%
SC	DC, 25 to 60 C.	40-160	40	.03	.05	90-98%	65-80%
SC	DC, 25 to 60 C.	4-100*	10-15-20	1.7-0.6-0.18	5-1-0.2	90-98%	65-80%
SC-1	DC, 25 to 60 C.	.5-2	1.5	100	210	35-60%	25-40%
SC-1	DC, 25 to 60 C.	1-4	3	24	60	35-60%	25-40%
SC-1	DC, 25 to 60 C.	2-8	6	6	16	35-60%	25-40%
SC-1	DC, 25 to 60 C.	4-16	12	1.5	5	35-60%	25-40%
SC-1	DC, 25 to 60 C.	10-40	25	.25	.65	35-60%	25-40%
SC-1	DC, 25 to 60 C.	20-80	40	.07	.16	35-60%	25-40%
SC-1	DC, 25 to 60 C.	40-160	40	.03	.05	35-60%	25-40%
SC-1	DC, 25 to 60 C.	4-100*	10-15-20	1.7-0.6-0.18	5-1-0.2	35-60%	25-40%

* Coil has taps on which minimum pickups are 10 and 30 amperes.

CHARACTERISTICS OF SV AND SV-1 RELAYS

Type	Frequency (Cycles)	Range of Adjustment Volts	Max. Volts Continuous	Watts at 115 V. AC (125 V. for DC)	V.A. at 115 V.	Dropout Ratio
SV	60	70-160	160	3.4	7.3	90-98%
SV	50	70-160	180	2.8	6.1	90-98%
SV	25	70-160	200	1.5	2.5	90-98%
SV	DC	50-150	150	4.8		65-80%
SV-1	60	70-160	160	4.1	8.5	40-80%
SV-1	50	70-160	180	3.5	7.1	40-80%
SV-1	25	70-160	200	1.4	3.2	40-80%
SV-1	DC	50-150	150	4.8		25-40%

NOTES:--Standard current relays are calibrated on 60 cycles. This calibration is approximately correct for 25 cycle and DC applications, but there will be discrepancies of 10% to 15% at some points on the scale.

Values of watts and volt-amperes in the tables are average for various plunger and shunt position.

For the SC relay, volt-amperes for pickup at minimum setting are approximately 3.4 and 1.4 for 60 and 25 cycles. Watts at minimum setting are approximately 1.0, .65 and .57 for 60 cycles, 25 cycles and DC respectively. Multiply values by 16 for approximate burdens at maximum setting.

For the SC-1 relay, volt-amperes for pickup at minimum setting are approximately 3.5 and 1.3 for 60 and 25 cycles. Watts at minimum settings are 1.3, .7 and .57 for 60 cycles, 25 cycles and d-c, respectively. Multiply values by 16 for approximate burdens at maximum setting.

*The V.A. burdens of the SC and SC-1 relays at 3, 10 and 20 times minimum pickup current are approximately 31, 240 and 770 V.A. respectively.

Dropout ratio varies somewhat with pickup adjustment but will be approximately constant for any given pickup setting. Limits in tables include variables such as friction and other individual relay variations.

Maximum continuous volts given for the SV and SV-1 relays for A-C are for the relay set for minimum pickup. With the relay set for maximum pickup the continuous voltage can be increased 10 to 20%.

TYPES SC, SC-1, SV AND SV-1 RELAYS

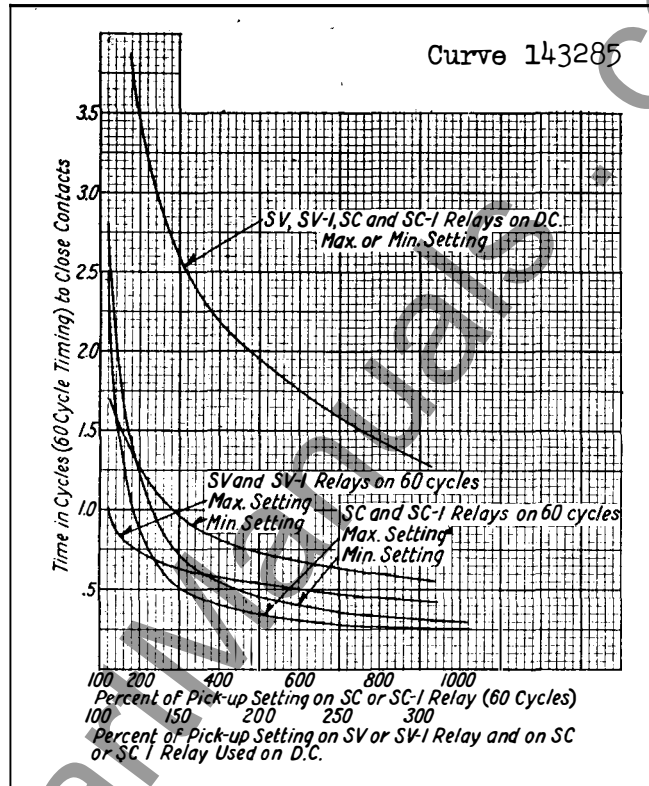
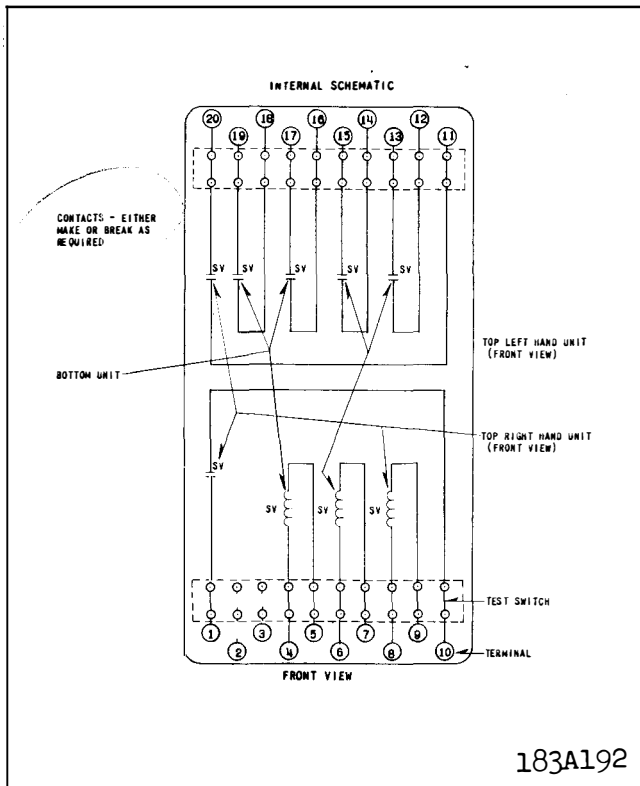

Fig. 7. Internal Schematic of the Three Unit Type SV or SV-1 Relay in the Type FT32 Case.

Fig. 8. Typical Time Curves for the Types SC and SV Relays (Using Flux Shunt for Pick-up Adjustment.)

shaped bushing assembled on the upper end of the plunger shaft has a portion of its center section machined off so that the shaft is exposed at this point and can be prevented from turning by gripping shaft and bushing with a pair of longnose pliers while removing the set screw and nut. Then by pressing down with the fingers on the upper end of the shaft, the lower split sleeve which retains the lower bearing will be forced out of the threaded tube, the bearing will drop out freely, and the upper split sleeve will be forced out far enough to permit grasping it for removal. The shaft and plunger assembly then can be removed.

The shaft and plunger assembly should be handled carefully to avoid bending the shaft or damaging the bearing surfaces. The shaft should never be gripped on its upper bearing surface, below the spool-shaped bushing, when loosening the nut and set screw, as this would almost certainly damage the bearing surface. The shaft bearing surfaces should not be

cleaned or polished with any abrasive material, as the abrasive particles might become imbedded in the shaft and cause difficulty later. The plunger shaft and bearings may be cleaned by wiping them carefully with a clean, lintless cloth. This may be moistened with benzene or some other cleaning solvent if necessary. Use no lubricant on the plunger shaft or bearings when reassembling the relay, since this will eventually become gummy and prevent proper operation. It is recommended that the shaft be cleaned at intervals of approximately two years. When replacing the lower bearing and the split sleeves, the shorter sleeve (assembled below the bearing) should be pushed in until it is flush with the end of the threaded tube.

The mounting holes in the operation indicator screen are slotted so that its position can be adjusted. For relays in which the moving contacts are not latched in the operated position, the screen should be so located

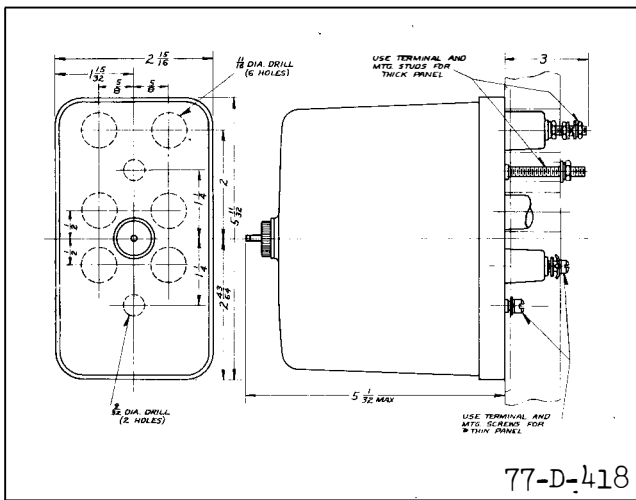
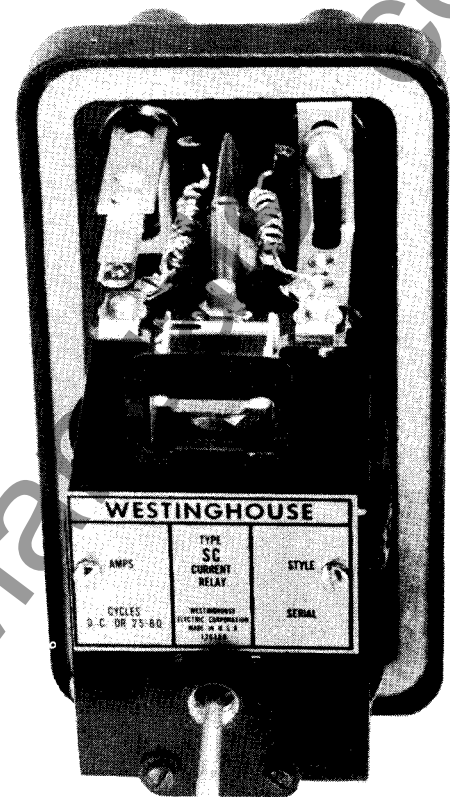

Fig. 9. Outline & Drilling Plan for Single Unit Relays in Small Glass Projection Case.

that the indicator positively enters the screen opening when the contacts barely touch. For latch-type relays, the screen should be so located that good contact is still obtained when the relay is de-energized. The pressure of the screen against the indicator may be adjusted by bending the screen between its lower end and the large elongated hole. This pressure should be such that the indicator will be held at any further position to which it is moved after entering the screen opening. However, the minimum amount of pressure necessary to obtain this adjustment should not be exceeded appreciably, since the pick-up value, and consequently the ratio, will be affected. The purpose of this pressure is to eliminate indicator rattle which might otherwise occur under certain energized conditions.

The moving contact leads pass through insulation sleeves assembled on the shanks of the terminal clips which are attached to the base terminals. These sleeves are notched at their upper ends, and the notches are toward the center of the relay. The leads are bent at approximately a right angle where they pass out through the notches, which aids in preventing them from coming into contact with the stationary contact brackets. Figure 11 shows properly coiled and assembled moving contact leads.



N331622

Fig. 10. View of Type SC Relay Showing Correct Shaping of Moving Contact Leads.

Although the moving contact leads are very flexible, if the leads have been pulled out of their original shape by handling they may exert sufficient side pressure on the shaft bearing or twisting force against the guide post to cause appreciable friction and wear. If this condition continues for a long period of time, the resulting wear may affect the relay calibration or the dropout ratio noticeably. In extreme cases the wear may progress to a degree which may occasionally cause failure of the plunger to drop down when the relay is de-energized.

Correct shaping of the leads is not difficult, and they may be checked readily by removing the guide post and the nut at the top of the shaft. The plunger should be held in the raised position, either by energizing the relay or by pressing lightly against the collar under the insulation plate after raising

TYPES SC, SC-1, SV AND SV-1 RELAYS

the plunger manually. With the plunger raised, the insulation plate should be oscillated slightly in a horizontal plane by twisting it horizontally and releasing it. If in several trials the plate comes to rest with the center line of the contacts approximately parallel to the base and with its mounting hole fairly well centered with the end of the shaft, if the plate does not tip appreciably, and if the leads have a safe clearance to the stationary contact brackets, the leads are properly shaped.

If this check shows that re-shaping is necessary, it may be possible to obtain sufficient correction by bending the leads sharply where they emerge from the insulation sleeves. One or two pairs of tweezers are convenient tools for re-shaping the leads. If it is necessary to re-coil the leads, they should be wound around a rod having a diameter of approximately $5/32$ ". The coils then should be stretched out just enough to avoid side pull or twisting force on the plunger assembly.

In all relays except the SV-1 relay for A-C, if the stationary contacts are assembled so that they close when the relay is energized, they should be located so that they barely touch the moving contacts when the latter are $5/32$ " above the de-energized position. The moving contacts can be held in this position while the adjustment is being made by inserting a $5/32$ " spacer between the shaft collar

and the top of the core. This dimension should be $3/16$ " on the SV-1 relay for A-C. Both contacts should touch at the same time when the plunger is raised. When the plunger is moved upward against its stop, there should be a slight deflection of the stationary contact stop springs, but this should not exceed $1/32$ ". When the stationary contacts are reversed so that they are closed when the relay is de-energized, they should be located so that they just touch the moving contacts when the latter are $1/32$ " above the de-energized position. On some relays it may be found that when the contacts are used in this position the relay may operate at values a few percent below the scale markings. The adjustments specified for the stationary contacts are important. Failure to observe them may cause improper relay operation, either directly or after a period of service. Contact position should not be used as a means of altering the ratio of dropout to pickup.

RENEWAL PARTS

Repair work can be done most satisfactorily at the factory. However, interchangeable parts can be furnished to the customers who are equipped for doing repair work. When ordering parts, always give the complete name-plate data.

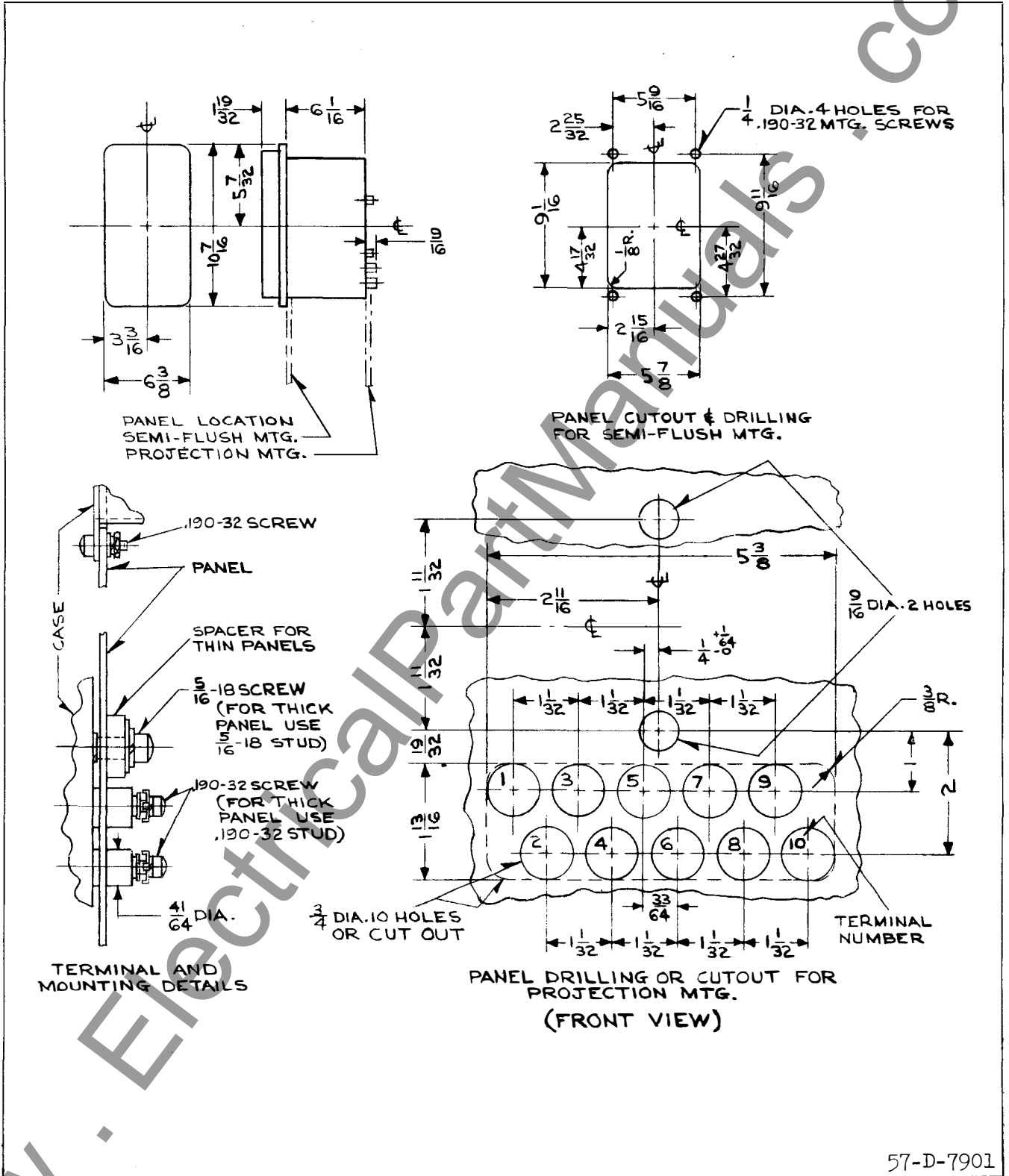

Fig. 11. Outline & Drilling Plan for Single & Double Unit Relays in the Type FT21 Case.

www.ElectricalPartManuals.com



WESTINGHOUSE ELECTRIC CORPORATION
RELAY-INSTRUMENT DIVISION

NEWARK, N. J.

Printed in U.S.A.

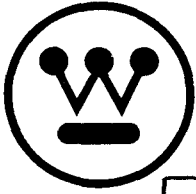

INSTALLATION • OPERATION • MAINTENANCE I N S T R U C T I O N S

TYPES SC, SC-1, SV AND SV-1 RELAYS

Note - Not recommended to keep a SV Relay energized at all times - (See over.)

CAUTION Before putting protective relays into service, remove all blocking which may have been inserted for the purpose of securing the parts during shipment, make sure that all moving parts operate freely, inspect the contacts to see that they are clean and close properly, and operate the relay to check the settings and electrical connections.

APPLICATION

The types SC and SC-1 current relays and the types SV and SV-1 voltage relays are applicable where an instantaneous plunger relay of high accuracy is required. These relays are suitable for protective service, and for auxiliary service where some of their special features are desired. They are adjustable over a wide range of voltage or current, are provided with mechanical operation indicators, and have a calibrated scale which indicates the pick-up setting. Both contacts can readily be changed from "make" to "break". The volt-ampere burden is low.

The type SC and SV relays have a high ratio of drop-out to pick-up (90 to 98%) and are particularly suitable for fault detector relays. The type SC-1 and SV-1 relays have a lower ratio of drop-out to pick-up. This lower ratio may be desirable in some applications, and it makes possible a plunger pull characteristic which permits the operation of a latching device. The latch is combined with the mechanical operation indicator, and prevents further motion of the moving contacts after the relay has operated.

CONSTRUCTION

The types SC, SC-1 and SV and SV-1 relays operate on the solenoid principle. A U-shaped iron frame, mounted on the moulded base, supports the coil and serves as the external magnetic path for the coil. The coil surrounds a core and flux shunt. The upper end of the core is threaded and projects through the upper side of the frame, to which it is fastened by a nut. A tube threaded on the outside at its lower end is assembled in the core, and the threaded end extends below the core. A Fluorosint® bushing, which is the lower

® The Polymer Corp.
SUPERSEDES I.L. 41-766.1F

*Denotes change from superseded issue.

bearing for the plunger shaft, is assembled in the lower end of this threaded tube. It is held in place by two split spring sleeves, one above and one below the bearing. The split sleeves must be compressed to insert them in the tube and they will remain at any position in which they are placed. The bearing for * the upper end of the plunger shaft is a Fluorosint® bushing which is pressed in the upper end of the core. This bearing is visible when the plunger is in the energized position. The plunger itself does not touch the walls of the tube in which it moves.

A flux shunt which surrounds the core is screwed on the tube, and its lower end projects below the relay frame. The position of this shunt determines the pick-up setting of the relay. The lower end of the shunt is beveled and knurled, so that it can be grasped by the fingers and turned to change the setting. A calibrated scale plate is mounted adjacent to the shunt. A groove just above the knurl in the lower end of the shunt serves as an index mark, and the relay pick-up setting is indicated by the calibration scale marking which is adjacent to the groove.

The construction of the plunger, core and flux shunt (which differ in details in the various types of these relays) causes the plunger to float in its energized position, without being held against a stop, even when energized much above the pick-up value. Consequently, there is negligible noise and the contacts are free from chatter, even on heavy overloads and in 25 cycle applications.

The core, shunt and plunger construction also provides the high ratio of drop-out to pickup in the SC and SV relays. This ratio is above 90% for any pick-up setting. In the latch type relays it is necessary for the plunger to rise with sufficient force to operate the latch positively and to deflect the stationary contacts sufficiently to prevent their opening, when the relay is de-energized, due to play in the latch. It is necessary to have a lower ratio of drop-out to pick-up in, order to obtain this characteristic, and this lower ratio may be desirable in some applications where the latch is not required. The plunger

TYPES SC, SC-1, SV AND SV-1 RELAYS

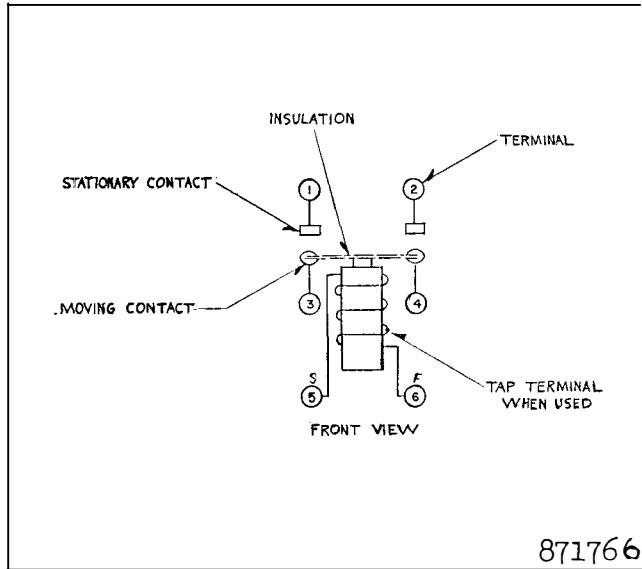

Fig. 1. Internal Wiring of the Relays In The Small Glass Case.

floats in its operated position just as in the SC and SV relays. The drop-out ratio varies somewhat for different shunt positions, but is constant for any one setting.

The shunt is held in any desired position by pressure from a curved arm made of sheet spring steel, which is fastened to the bottom of the coil frame at the rear of the shunt. This spring arm is shaped to extend around the shunt to the front of the relay, and in its normal position it exerts sufficient pressure against the shunt to prevent any creeping of the shunt or undesired change of setting. The front end of the spring arm has a bent-over tab on which thumb-pressure may be applied to move the arm out of contact with the shunt while the position of the latter is being changed.

The stationary contacts are assembled on slotted brackets. These are held in position on the base by filister-head screws which are threaded into the terminal inserts. Lock-washers are assembled inside the moulded terminal bushings between the inserts and the base, as a safeguard against loosening of the screws. By rotating the bracket on its mounting screw and moving it along its slot, the contact assembly can be made either normally open or normally closed. The moving contacts are mounted on a Micarta insulation plate which is secured to the threaded end of the plunger shaft by a nut. The front edge of this insulation plate operates the indicator. The rear portion of the plate is slotted and a post screwed to the frame passes through this slot to prevent the plate from rotating.

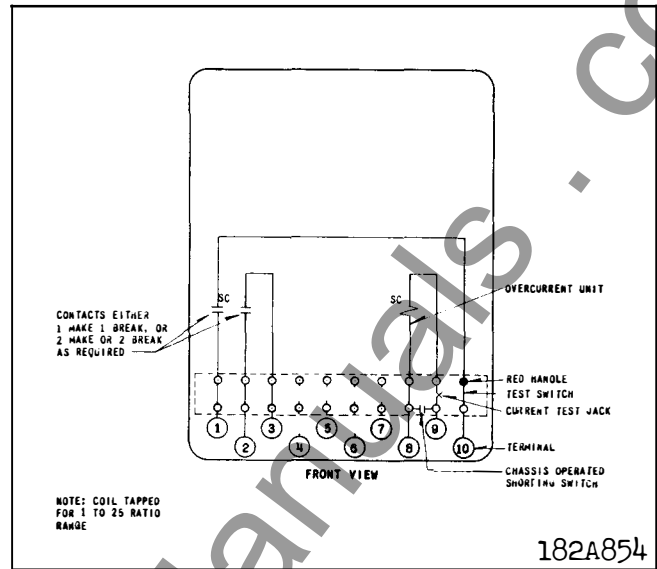

Fig. 2. Internal Schematic of the Single Unit Type SC or SC-1 Relay in The Type FT21 Case.

The moving contacts are double-faced so that they can be "make" or "break" and are connected to the base terminals by flexible leads. All contacts are pure silver. The contacts will carry 5 amperes continuously, and will interrupt 5 amperes at 115 volts A-C, or 1 ampere at 125 volts D-C.

The mechanical operation indicators used on these relays are shockproof, and can be used to indicate on the up stroke or down stroke of the plunger. The indicator is reset by pulling out the knurled stud which projects through the cover nut. The indicator should be reset after each relay operation because otherwise there may be a one or two percent decrease in the operating value of the relay. The operation indicator is assembled at the factory to indicate on the up stroke of the plunger, but by removing the two mounting screws which fasten the indicator to the main frame, turning the indicator bracket around and at the same time swinging the indicator flag 180° about its shaft, the indicator can be set to indicate on the down stroke of the plunger. The rivet weight must be removed from the indicator flag and the latch screen turned around to complete the assembly.

In certain applications, an extremely wide range of current adjustment is desirable, and certain styles of SC and SC-1 relays have been provided with tapped coils to meet this requirement. The coil taps are brought out to a tap block mounted on the lower end of the relay frame or on the relay sub-base, depending on the type of case used. The connector plate on the tap block is marked with the minimum pick-up value of

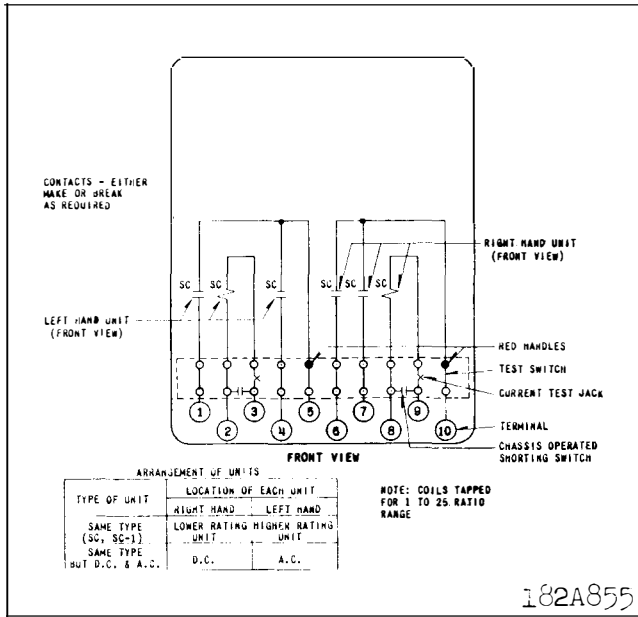

Fig. 3. Internal Schematic of the Double Unit Type SC or SC-1 Relay in the Type FT21 Case.

each tap, and the shunt is adjusted in the usual manner to obtain any pick-up setting between taps. The scale plate is not calibrated for the relays with tapped coils, as there is not sufficient space for marking a scale for each tap. However, the scale plate is supplied in order that a customer may mark on it the individual relay setting or settings if desired.

INSTALLATION

The relays should be mounted on switchboard panels or their equivalent in a location free from dirt, moisture, excessive vibration, and heat. Mount the relay vertically by means of the four mounting holes on the flange for semi-flush mounting or by means of the rear mounting stud or studs for projection mounting. Either a mounting stud or the mounting screws may be utilized for grounding the relay. The electrical connections may be made directly to the terminals by means of screws for steel panel mounting or to the terminal studs furnished with the relay for thick panel mounting. The terminal studs may be easily removed or inserted by locking two nuts on the stud and then turning the proper nut with a wrench.

For detailed FT case information refer to I.L. 41-076.

ADJUSTMENTS AND MAINTENANCE

The proper adjustments to insure correct operation of this relay have been made at the factory and

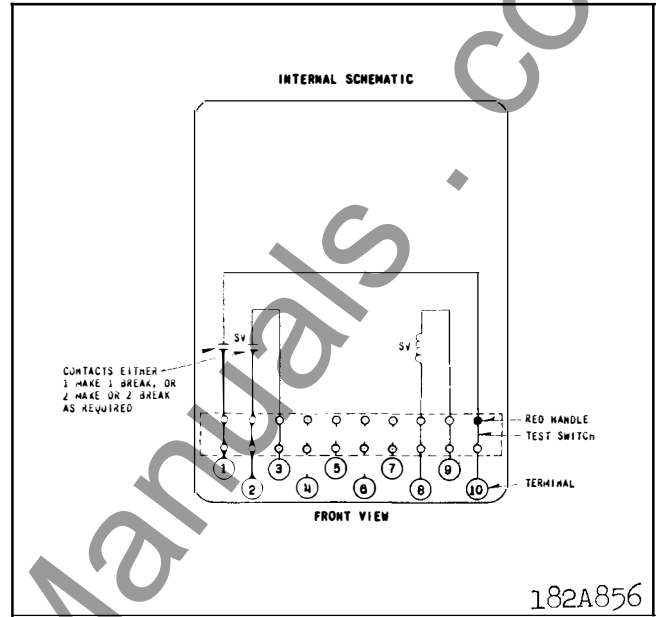

Fig. 4. Internal Schematic of the Single Unit Type SV or SV-1 Relay in the Type FT21 Case.

should not be disturbed after receipt by the customer. If the adjustments have been changed, the relay taken apart for repairs, or if it is desired to check the adjustments at regular maintenance periods, the instructions below should be followed.

All contacts should be cleaned periodically. A contact burnisher S#182A836H01 is recommended for this purpose. The use of abrasive material for cleaning contacts is not recommended, because of the danger of embedding small particles in the face of the soft silver and thus impairing the contact.

Several factors may affect the drop-out ratio of the relay. Whatever affects the ratio does so because either the drop-out or pick-up or both are affected. Obviously, incorrect assembly or interchange of parts, such as the use of the SC plunger with the SV core tube, will alter the electrical characteristics. However, the factor most likely to be encountered in service is friction. This may be due to dirt or foreign material between the plunger shaft and its bearings, to excessive pressure of the indicator screen on the indicator, or to leads so mis-shaped that they tend to rotate or tilt the moving contact insulation plate with appreciable force.

In order to remove the plunger and shaft assembly, it is necessary to remove the setscrew and nut at the top of the shaft. The spool-shaped bushing assembled on the upper end of the plunger shaft has a portion of

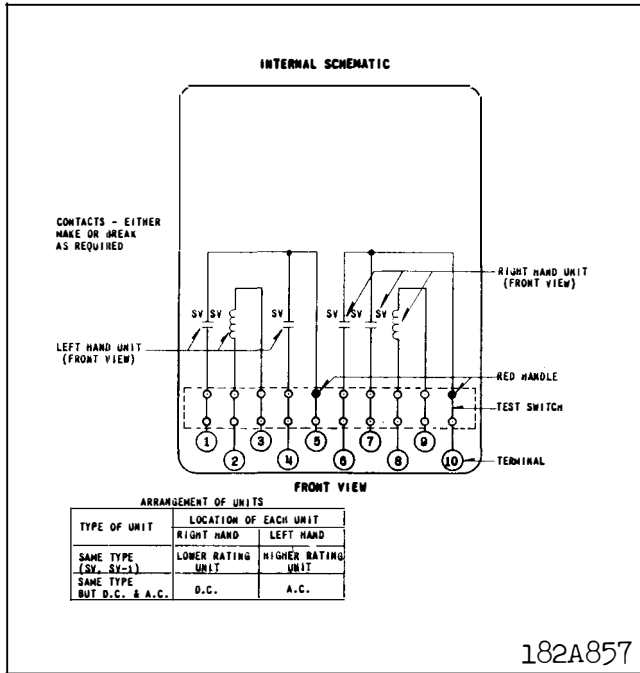

Fig. 5. Internal Schematic of the Double Unit Type SV or SV-1 Relay in the Type FT32 Case.

its center section machined off so that the shaft is exposed at this point and can be prevented from turning by gripping shaft and bushing with a pair of long-nose pliers while removing the set screw and nut. Then by pressing down with the fingers on the upper end of the shaft, the lower split sleeve which retains the lower bearing will be forced out of the threaded tube, the bearing will drop out freely, and the upper split sleeve will be forced out far enough to permit grasping it for removal. The shaft and plunger assembly then can be removed.

The shaft and plunger assembly should be handled carefully to avoid bending the shaft or damaging the bearing surfaces. The shaft should never be gripped on its upper bearing surface, below the spool-shaped bushing, when loosening the nut and setscrew, as this would almost certainly damage the bearing surface. The shaft bearing surfaces should not be cleaned or polished with any abrasive material, as the abrasive particles might become imbedded in the shaft and cause difficulty later. The plunger shaft and bearings may be cleaned by wiping them carefully with a clean, lint-less cloth. This may be moistened with benzene or some other cleaning solvent if necessary. Use no lubricant on the plunger shaft or bearings when re-assembling the relay, since this will eventually become gummy and prevent proper operation. It is recommended that the shaft be clean-

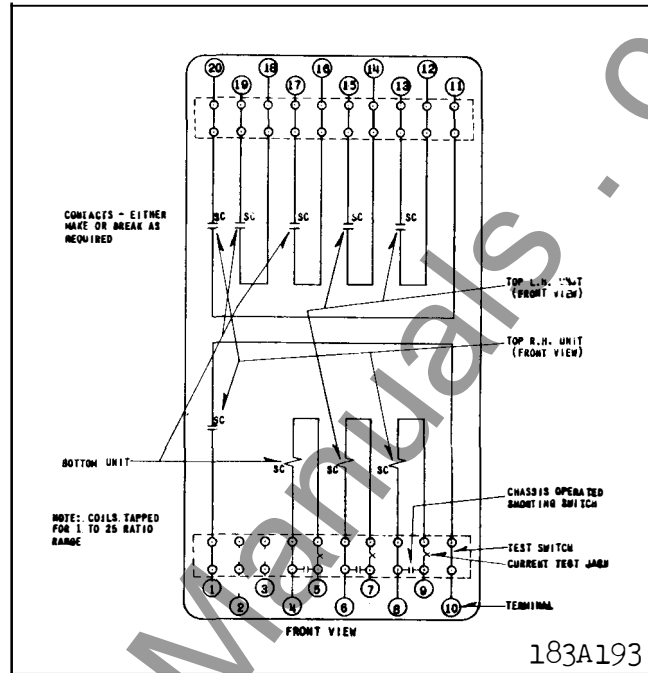

Fig. 6. Internal Schematic of the Three Unit Type SC or SC-1 Relay in the Type FT32 Case.

ed at intervals of approximately two years. When replacing the lower bearing and the split sleeves, the shorter sleeve (assembled below the bearing) should be pushed in until it is flush with the end of the threaded tube.

The mounting holes in the operation indicator screen are slotted so that its position can be adjusted. For relays in which the moving contacts are not latched in the operated position, the screen should be so located that the indicator positively enters the screen opening when the contacts barely touch. For latch-type relays, the screen should be so located that good contact is still obtained when the relay is de-energized. The pressure of the screen against the indicator may be adjusted by bending the screen between its lower end and the large elongated hole. This pressure should be such that the indicator will be held at any further position to which it is moved after entering the screen opening. However, the minimum amount of pressure necessary to obtain this adjustment should not be exceeded appreciably, since the pick-up value, and consequently the ratio, will be affected. The purpose of this pressure is to eliminate indicator rattle which might otherwise occur under certain energized conditions.

The moving contact leads pass through insulation sleeves assembled on the shanks of the terminal clips

CHARACTERISTICS OF TYPES SC AND SC-1 RELAYS

Type	Frequency	Range of Adjustment Amps.	Max. Amps. Continuous	Watts 5 Amps. 60 Cycles	V.A. at 5 Amps. 60 Cycles	Dropout Ratio-AC	Dropout Ratio-DC
SC	DC, 25 to 60 hz.	.5-2	1.5	99	225	90-98%	65-80%
SC	DC, 25 to 60 hz.	1-4	3	28	65	90-98%	65-80%
SC	DC, 25 to 60 hz.	2-8	6	6.9	19	90-98%	65-80%
SC	DC, 25 to 60 hz.	4-16	12	1.5	5	90-98%	65-80%
SC	DC, 25 to 60 hz.	10-40	25	.24	.7	90-98%	65-80%
SC	DC, 25 to 60 hz.	20-80	40	.07	.16	90-98%	65-80%
SC	DC, 25 to 60 hz.	40-160	40	.03	.05	90-98%	65-80%
SC	DC, 25 to 60 hz.	4-100*	10-15-20	1.7-0.6-0.18	5-1-0.2	90-98%	65-80%
SC-1	DC, 25 to 60 hz.	.5-2	1.5	100	210	35-60%	25-40%
SC-1	DC, 25 to 60 hz.	1-4	3	24	60	35-60%	25-40%
SC-1	DC, 25 to 60 hz.	2-8	6	6	16	35-60%	25-40%
SC-1	DC, 25 to 60 hz.	4-16	12	1.5	5	35-60%	25-40%
SC-1	DC, 25 to 60 hz.	10-40	25	.25	.65	35-60%	25-40%
SC-1	DC, 25 to 60 hz.	20-80	40	.07	.16	35-60%	25-40%
SC-1	DC, 25 to 60 hz.	40-160	40	.03	.05	35-60%	25-40%
SC-1	DC, 25 to 60 hz.	4-100*	10-15-20	1.7-0.6-0.18	5-1-0.2	35-60%	25-40%

* Coil has taps on which minimum pickups are 10 and 30 amperes.

CHARACTERISTICS OF SV AND SV-1 RELAYS

Type	Frequency (Cycles)	Range of Adjustment Volts	Max. Volts Continuous	Watts at 115 V. AC (125 V. for DC)	V.A. at 115 V.	Dropout Ratio
SV	60	7-16	16	-	-	90-98%
SV	60	70-160	160	3.4	7.3	90-98%
SV	60	140-320	320	-	-	90-98%
SV	60	280-640	640	-	-	90-98%
SV	50	70-160	180	2.8	6.1	90-98%
SV	25	70-160	200	1.5	2.5	90-98%
SV	DC	50-150	150	4.8	-	65-80%
SV	DC	100-300	300	-	-	65-80%
SV-1	60	7-16	16	-	-	40-80%
SV-1	60	70-160	160	4.1	8.5	40-80%
SV-1	60	140-320	320	-	-	40-80%
SV-1	60	280-640	640	-	-	40-80%
SV-1	50	70-160	180	3.5	7.1	40-80%
SV-1	25	70-160	200	1.4	3.2	40-80%
SV-1	DC	50-150	150	4.8	-	25-40%
SV-1	DC	100-300	300	-	-	25-40%

NOTES:--Standard current relays are calibrated on 60 cycles. This calibration is approximately correct for 25 cycle and DC applications, but there will be discrepancies of 10% to 15% at some points of scale.

Values of watts and volt-amperes in the tables are average for various plunger and shunt position.

For the SC relay, volt-amperes for pickup at minimum setting are approximately 3.4 and 1.4 for 60 and 25 cycles. Watts at minimum setting are approximately 1.0, .65 and .57 for 60 cycles, 25 cycles and DC respectively. Multiply values by 16 for approximate burdens at maximum setting.

For the SC-1 relay, volt-amperes for pickup at minimum setting are approximately 3.5 and 1.3 for 60 and 25 cycles. Watts at minimum settings are 1.3, .7 and .57 for 60 cycles, 25 cycles and d-c respectively. Multiply values by 16 for approximate burdens at maximum setting.

*The V.A. burdens of the SC and SC-1 relays at 3, 10 and 20 times minimum pickup current are approximately 31, 240 and 770 V.A. respectively.

Dropout ratio varies somewhat with pickup adjustment but will be approximately constant for any given pickup setting. Limits in tables include variables such as friction and other individual relay variations.

Maximum continuous volts given for the SV and SV-1 relays for A-C are for the relay set for minimum pickup. With the relay set for maximum pickup the continuous voltage can be increased 10 to 20%.

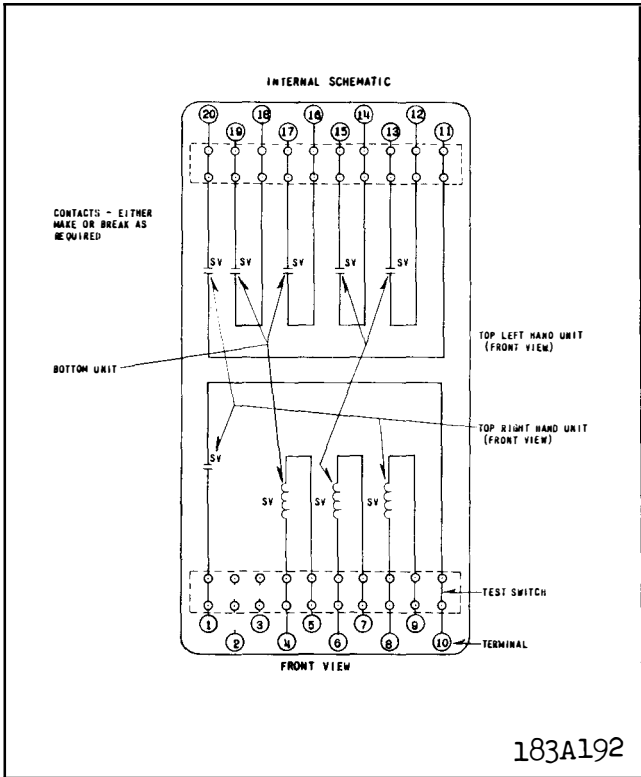

183A192

Fig. 7. Internal Schematic of the Three Unit Type SV or SV-1 Relay in the Type FT32 Case.

which are attached to the base terminals. These sleeves are notched at their upper ends, and the notches are toward the center of the relay. The leads are bent at approximately a right angle where they pass out through the notches, which aids in preventing them from coming into contact with the stationary contact brackets. Figure 11 shows properly coiled and assembled moving contact leads.

Although the moving contact leads are very flexible, if the leads have been pulled out of their original shape by handling they may exert sufficient side pressure on the shaft bearing or twisting force against the guide post to cause appreciable friction and wear. If this condition continues for a long period of time, the resulting wear may affect the relay calibration or or the dropout ratio noticeably. In extreme cases the wear may progress to a degree which may occasionally cause failure of the plunger to drop down when the relay is de-energized.

Correct shaping of the leads is not difficult, and they may be checked readily by removing the guide post and the nut at the top of the shaft. The plunger should be held in the raised position, either by energizing the relay or by pressing lightly against the

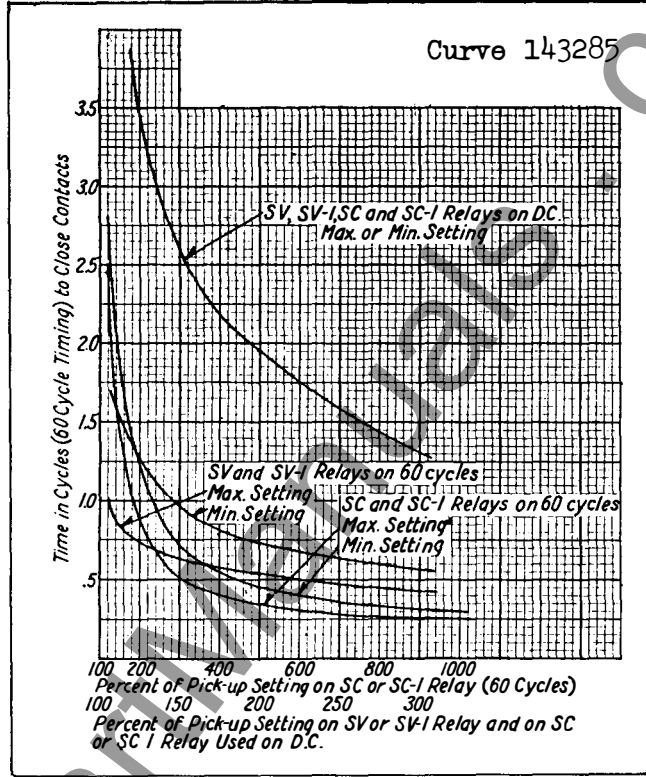

Fig. 8. Typical Time Curves for the Types SC and SV Relays (Using Flux Shunt for Pick-up Adjustment.)

collar under the insulation plate after raising the plunger manually. With the plunger raised, the insulation plate should be oscillated slightly in a horizontal plane by twisting it horizontally and releasing it. If in several trials the plate comes to rest with the center line of the contacts approximately parallel to the base and with its mounting hole fairly well centered with the end of the shaft, if the plate does not tip appreciably, and if the leads have a safe clearance to the stationary contact brackets, the leads are properly shaped.

If this check shows that re-shaping is necessary, it may be possible to obtain sufficient correction by bending the leads sharply where they emerge from the insulation sleeves. One or two pairs of tweezers are tools for re-shaping the leads. If it is necessary to re-coil the leads, they should be wound around a rod having a diameter of approximately 5/32". The coils then should be stretched out just enough to avoid side pull or twisting force on the plunger assembly.

In all relays except the SV-1 relay for A-C, if the stationary contacts are assembled so that they close when the relay is energized, they should be located so that they barely touch the moving contacts when

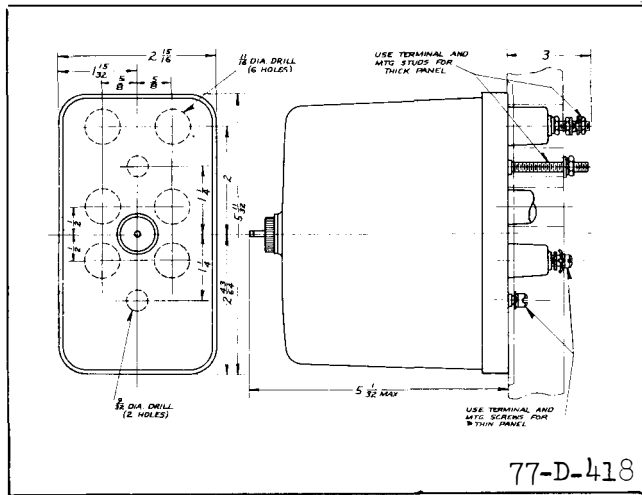

Fig. 9. Outline & Drilling Plan for Single Unit Relays in Small Glass Projection Case.

the latter are $5/32''$ above the de-energized position. The moving contacts can be held in this position while the adjustment is being made by inserting a $5/32''$ spacer between the shaft collar and the top of the core. This dimension should be $3/16''$ on the SV-1 relay for A-C. Both contacts should touch at the same time when the plunger is raised. When the plunger is moved upward against its stop, there should be a slight deflection of the stationary contact stop springs, but this should not exceed $1/32''$. When the stationary contacts are reversed so that they are closed when the relay is de-energized, they should be located so that they just touch the moving contacts when the latter are $1/32''$ above the de-energized position. On some relays it may be found that when the contacts are used in this position the relay may operate at values a few percent below the scale markings. The adjustments specified for the stationary contacts are important. Failure to observe them may cause improper relay operation, either directly or after a period of service. Contact position should not be used as a

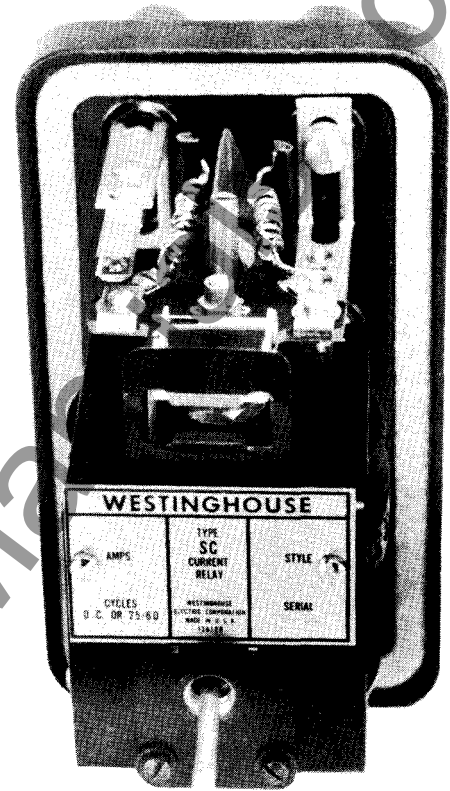

Fig. 10. View of Type SC Relay Showing Correct Shaping of Moving Contact Leads.

means of altering the ratio of dropout to pickup.

RENEWAL PARTS

Repair work can be done most satisfactorily at the factory. However, interchangeable parts can be furnished to the customers who are equipped for doing repair work. When ordering parts, always give the complete nameplate data.

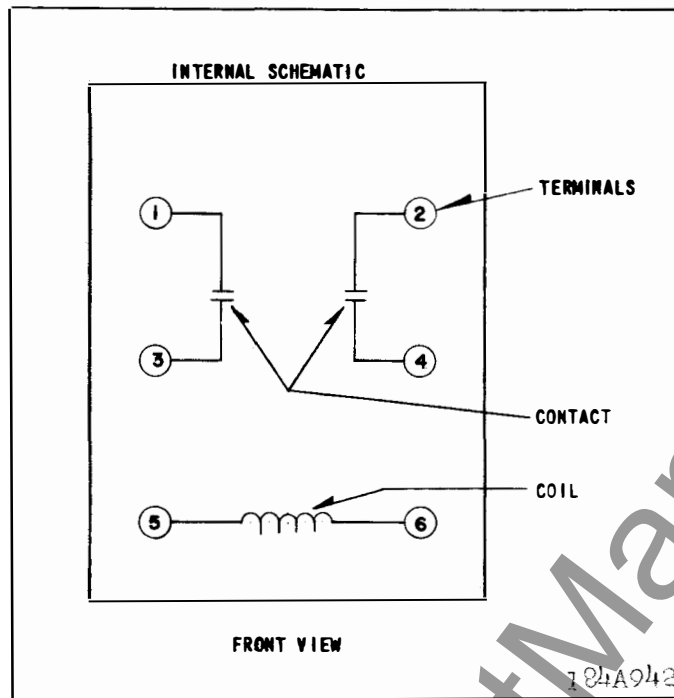

Fig. 11. Internal Schematic for Relays in Front Connected Case.

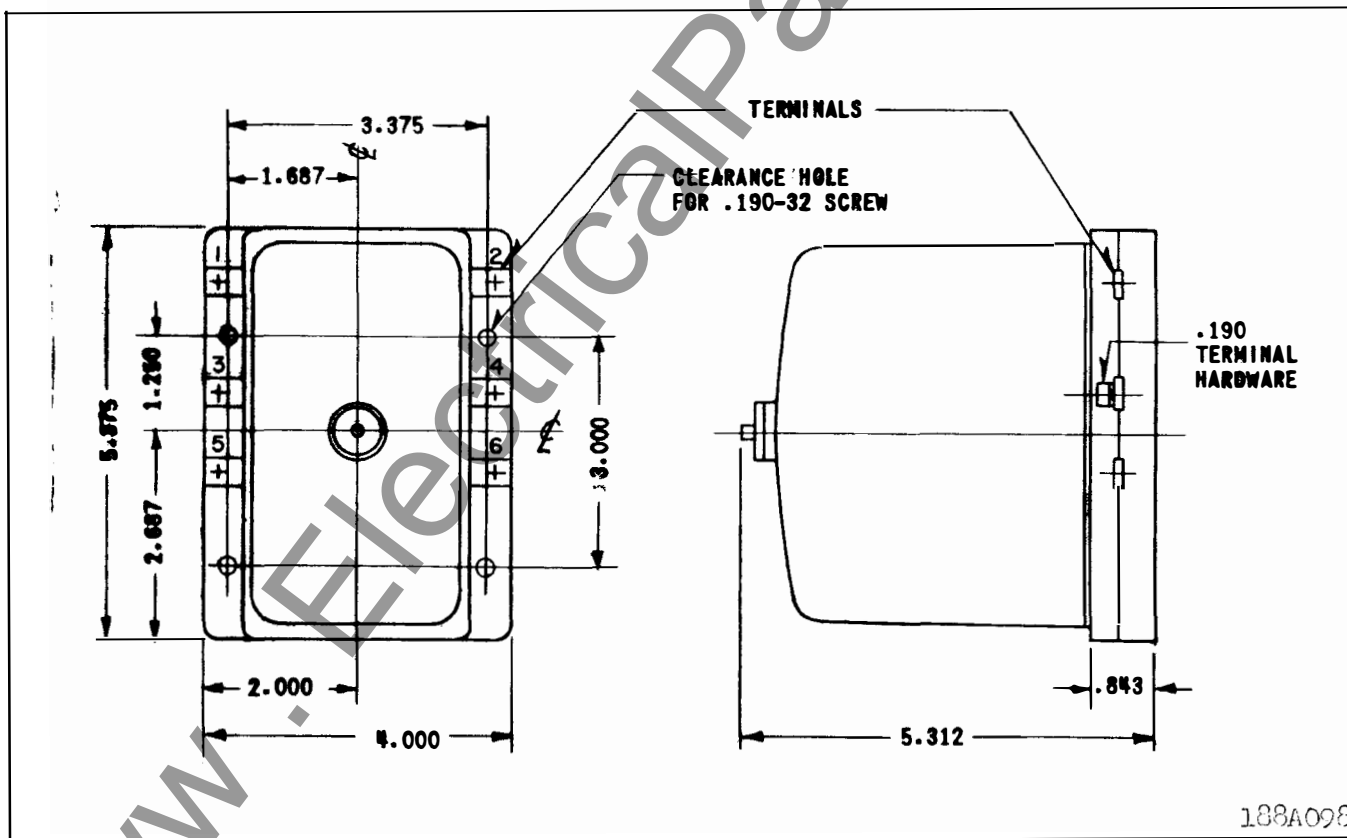

Fig. 12. Outline and Drilling Plan for Relays in Front Connected Case.

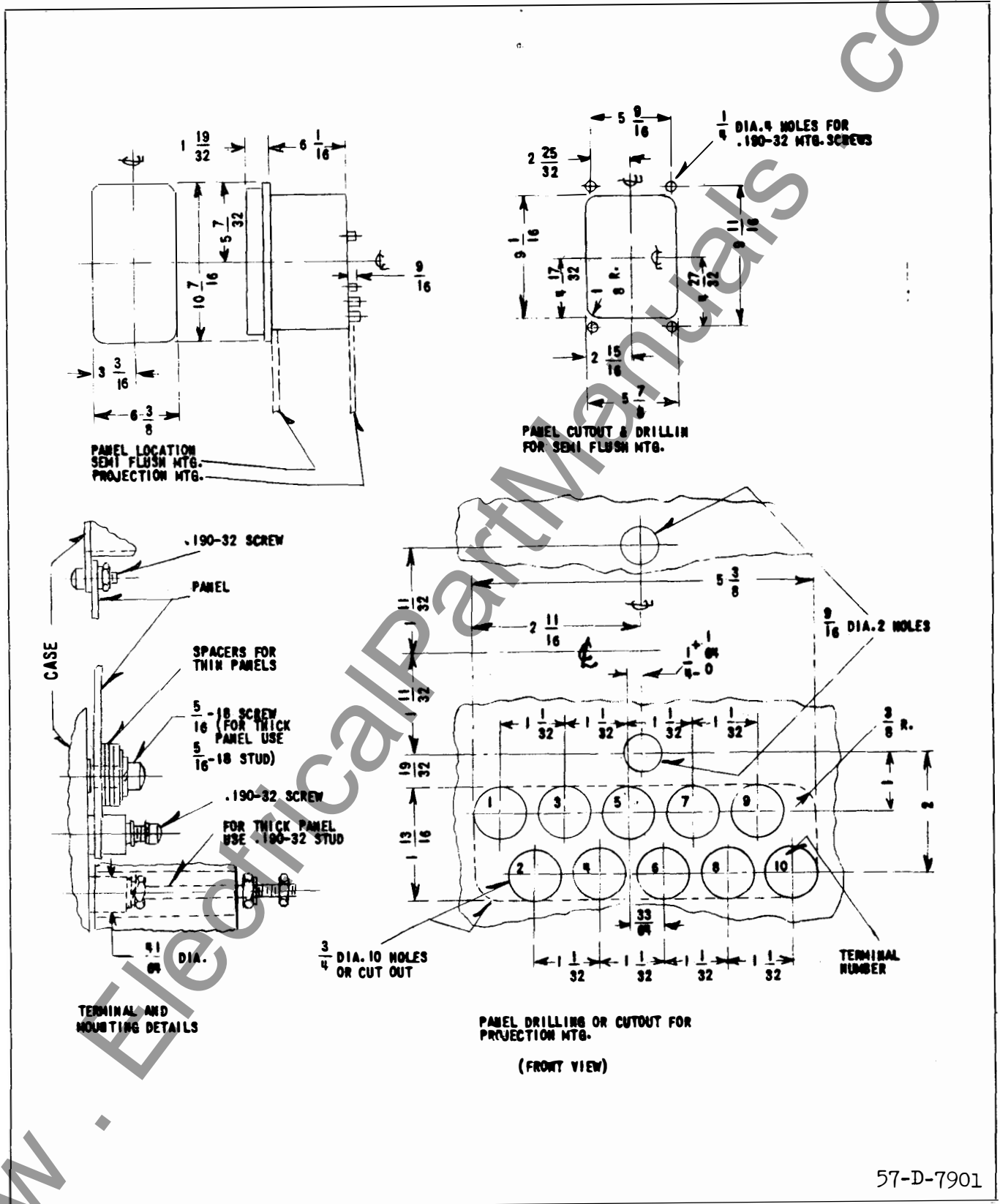

Fig. 13 Outline and Drilling Plan for Single and Double Unit Relays in the Type FT21 Case.

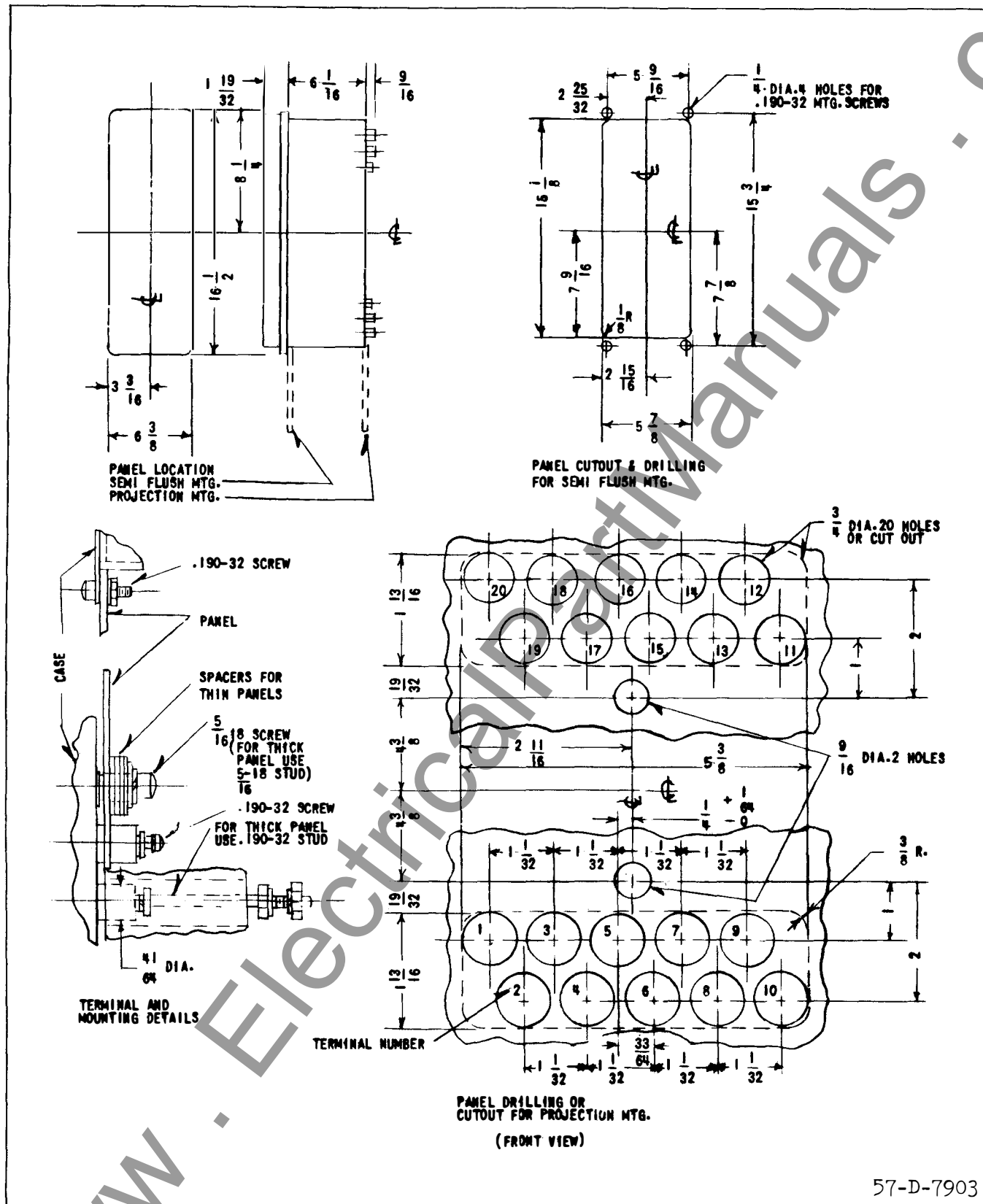

Fig. 14. Outline and Drilling Plan for Three Unit Relays in the Type FT32 Case.

www.ElectricalPartManuals.com

SV relay - The bearing & shaft are subject to vibration at twice freq. This causes particles to wear off shaft and drop into the bearing clearance. This can cause the shaft to wedge in the bearing and when the relay is de-energized it will not drop out -

Gen. H. Colburn -

2-8-79



WESTINGHOUSE ELECTRIC CORPORATION
RELAY-INSTRUMENT DIVISION

NEWARK, N. J.

Printed in U.S.A.

www.ElectricalPartManuals.com

www.ElectricalPartManuals.com



INSTALLATION • OPERATION • MAINTENANCE I N S T R U C T I O N S

TYPES SC, SC-1, SV AND SV-1 RELAYS

CAUTION Before putting protective relays into service, remove all blocking which may have been inserted for the purpose of securing the parts during shipment, make sure that all moving parts operate freely, inspect the contacts to see that they are clean and close properly, and operate the relay to check the settings and electrical connections.

APPLICATION

The types SC and SC-1 current relays and the types SV and SV-1 voltage relays are applicable where an instantaneous plunger relay of high accuracy is required. These relays are suitable for protective service, and for auxiliary service where some of their special features are desired. They are adjustable over a wide range of voltage or current, are provided with mechanical operation indicators, and have a calibrated scale which indicates the pickup setting. Both contacts can readily be changed from "make" to "break". The volt-ampere burden is low.

SC, SC-1, SV and SV-1

- ⊛ The SC and SV relays have a high ratio of dropout to pickup (90 to 98% for the ac relays). The SC-1 and SV-1 have a lower ratio of dropout to pickup (35 to 60% for the ac relays). These relays must not be used in critical applications where they may be picked up for prolonged periods of time.
- ⊛ The SC may be used in fault detector applications where direct energization of a breaker trip coil is involved. It should not be used to energize a timer. The SV should be used only in overvoltage applications.

CONSTRUCTION

The types SC, SC-1 and SV and SV-1 relays operate on the solenoid principle. A U-shaped iron frame, mounted on the moulded base, supports the coil and serves as the external magnetic path for the coil. The

coil surrounds a core and flux shunt. The upper end of the core is threaded and projects through the upper side of the frame, to which it is fastened by a nut. A tube threaded on the outside at its lower end is assembled in the core, and the threaded end extends below the core. A Fluorosint® bushing, which is the lower bearing for the plunger shaft, is assembled in the lower end of this threaded tube. It is held in place by two split spring sleeves, one above and one below the bearing. The split sleeves must be compressed to insert them in the tube and they will remain at any position in which they are placed. The bearing for the upper end of the plunger shaft is a Fluorosint® bushing which is pressed in the upper end of the core. This bearing is visible when the plunger is in the energized position. The plunger itself does not touch the walls of the tube in which it moves.

A flux shunt which surrounds the core is screwed on the tube, and its lower end projects below the relay frame. The position of this shunt determines the pick-up setting of the relay. The lower end of the shunt is beveled and knurled, so that it can be grasped by the fingers and turned to change the setting. A calibrated scale plate is mounted adjacent to the shunt. A groove just above the knurl in the lower end of the shunt serves as an index mark, and the relay pick-up setting is indicated by the calibration scale marking which is adjacent to the groove.

The construction of the plunger, core and flux shunt (which differ in details in the various types of these relays) causes the plunger to float in its energized position, without being held against a stop, even when energized much above the pickup value. Consequently, there is negligible noise and chatter, even on heavy overloads and in 25 hertz applications.

Ⓜ The Polymer Corp.

All possible contingencies which may arise during installation, operation, or maintenance, and all details and variations of this equipment do not purport to be covered by these instructions. If further information is desired by purchaser regarding his particular installation, operation or maintenance of his equipment, the local Westinghouse Electric Corporation representative should be contacted.

SUPERSEDES I.L. 41-766.1G, DATED FEBRUARY 1973
⊛ DENOTES CHANGE FROM SUPERSEDED ISSUE.

EFFECTIVE JULY 1978

TYPES SC, SC-1, SV AND SV-1 RELAYS

The core, shunt and plunger construction also provides the high ratio of dropout to pickup in the SC and SV relays. This ratio is above 90% for any pickup setting. In the latch type relays it is necessary for the plunger to rise with sufficient force to operate the latch positively and to deflect the stationary contacts sufficiently to prevent their opening, when the relay is de-energized, due to play in the latch. It is necessary to have a lower ratio of dropout to pickup in, order to obtain this characteristic, and this lower ratio may be desirable in some applications where the latch is not required. The plunger floats in its operated position just as in the SC and SV relays. The dropout ratio varies somewhat for different shunt positions, but is constant for any one setting.

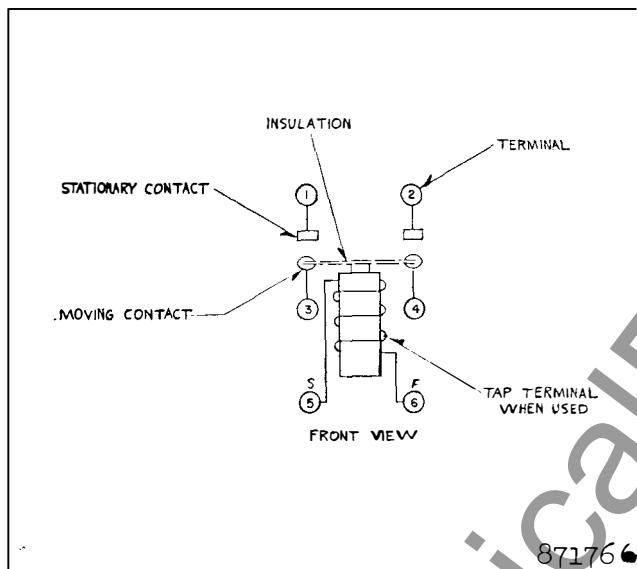

Fig. 1. Internal Wiring of the Relays In The Small Glass Case.

The shunt is held in any desired position by pressure from a curved arm made of sheet spring steel, which is fastened to the bottom of the coil frame at the rear of the shunt. This spring arm is shaped to extend around the shunt to the front of the relay, and in its normal position it exerts sufficient pressure against the shunt to prevent any creeping of the shunt or undesired change of setting. The front end of the spring arm has a bent-over tab on which thumb-pressure may be applied to move the arm out of contact with the shunt while the position of the latter is being changed.

The stationary contacts are assembled on slotted brackets. These are held in position on the base by filister-head screws which are threaded into the terminal inserts. Lock-washers are assembled inside the milled terminal bushings between the inserts and

the base, as a safeguard against loosening of the screws. By rotating the bracket on its mounting screw, and moving it along its slot, the contact assembly can be made either normally open or normally closed. The moving contacts are mounted on a Micarta insulation plate which is secured to the threaded end of the plunger shaft by a nut. The front edge of this insulation plate operates the indicator. The rear portion of the plate is slotted and a post screwed to the frame passes through this slot to prevent the plate from rotating.

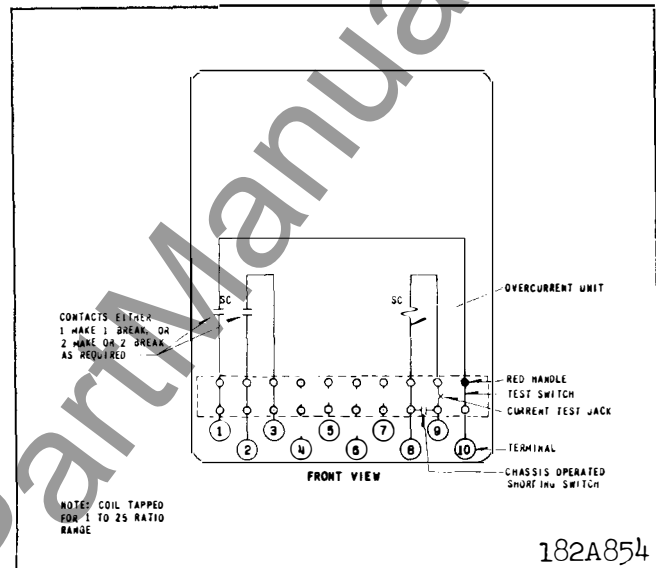

Fig. 2. Internal Schematic of the Single Unit Type SC or SC-1 Relay in The Type FT21 Case.

The moving contacts are double-faced so that they can be "make" or "break" and are connected to the base terminals by flexible leads. All contacts are pure silver. The contacts will carry 5 amperes continuously, and will interrupt 5 amperes at 115 volts ac, or 1 ampere at 125 volts dc.

The mechanical operation indicators used on these relays are shockproof, and can be used to indicate on the up stroke or down stroke of the plunger. The indicator is reset by pulling out the knurled stud which projects through the cover nut. The indicator should be reset after each relay operation because otherwise there may be a one or two percent decrease in the operating value of the relay. The operation indicator is assembled at the factory to indicate on the up stroke of the plunger, but by removing the two mounting screws which fasten the indicator to the main frame, turning the indicator bracket around and at the same time swinging the indicator flag 180° about its shaft, the indicator can be set to indicate on the down stroke of the plunger. The rivet weight must be removed from the indicator flag and the latch screen turned around to complete the assembly.

In certain applications, an extremely wide range of current adjustment is desirable, and certain styles of SC and SC-1 relays have been provided with tapped coils to meet this requirement. The coil taps are brought out to a tap block mounted on the lower end of the relay frame or on the relay sub-base, depending on the type of case used. The connector plate on the tap block is marked with the minimum pickup value of each tap, and the shunt is adjusted in the usual manner to obtain any pickup setting between taps. The scale plate is not calibrated for the relays with tapped coils, as there is not sufficient space for marking a scale for each tap. However, the scale plate is supplied in order that a customer may mark on it the individual relay setting or settings if desired.

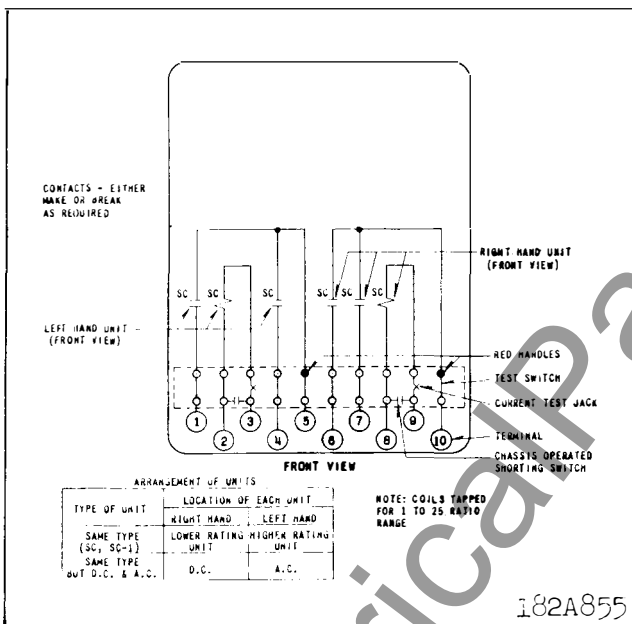

Fig. 3. Internal Schematic of the Double Unit Type SC or SC-1 Relay in the Type FT21 Case.

INSTALLATION

The relays should be mounted on switchboard panels or their equivalent in a location free from dirt, moisture, excessive vibration, and heat. Mount the relay vertically by means of the four mounting holes on the flange for semi-flush mounting or by means of the rear mounting stud or studs for projection mounting. Either a mounting stud or the mounting screws may be utilized for grounding the relay. The electrical connections may be made directly to the terminals by means of screws for steel panel mounting or to the terminal studs furnished with the relay for thick panel mounting. The terminal studs may be easily removed or inserted by locking two nuts on the stud and then turning the proper nut with a wrench.

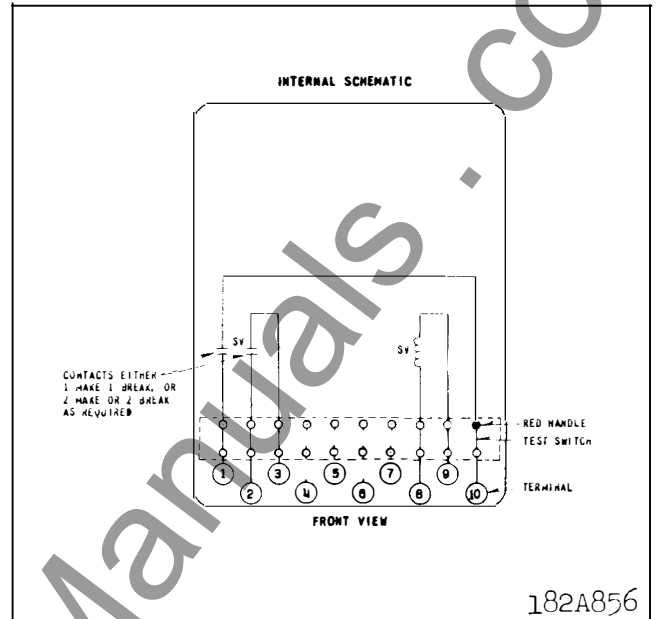

Fig. 4. Internal Schematic of the Single Unit Type SV or SV-1 Relay in the Type FT21 Case.

For detailed FT case information refer to I.L. 41-076.

ADJUSTMENTS AND MAINTENANCE

The proper adjustments to insure correct operation of this relay have been made at the factory and should not be disturbed after receipt by the customer. If the adjustments have been changed, the relay taken apart for repairs, or if it is desired to check the adjustments at regular maintenance periods, the instructions below should be followed.

All contacts should be cleaned periodically. A contact burnisher S#182A836H01 is recommended for this purpose. The use of abrasive material for cleaning contacts is not recommended, because of the danger of embedding small particles in the face of the soft silver and thus impairing the contact.

Several factors may affect the dropout ratio of the relay. Whatever affects the ratio does so because either the dropout or pickup or both are affected. Obviously, incorrect assembly or interchange of parts, such as the use of the SC plunger with the SV core tube, will alter the electrical characteristics. However, the factor most likely to be encountered in service is friction. This may be due to dirt or foreign material between the plunger shaft and its bearings, to excessive pressure of the indicator screen on the indicator, or to leads so mis-shaped that they tend to rotate or tilt the moving contact insulation plate with appreciable force.

TYPES SC, SC-1, SV AND SV-1 RELAYS

In order to remove the plunger and shaft assembly, it is necessary to remove the setscrew and nut at the top of the shaft. The spool-shaped bushing assembled on the upper end of the plunger shaft has a portion of its center section machined off so that the shaft is exposed at this point and can be prevented from turning by gripping shaft and bushing with a pair of long-nose pliers while removing the set screw and nut. Then by pressing down with the fingers on the upper end of the shaft, the lower split sleeve which retains the lower bearing will be forced out of the threaded tube, the bearing will drop out freely, and the upper split sleeve will be forced out far enough to permit grasping it for removal. The shaft and plunger assembly then can be removed.

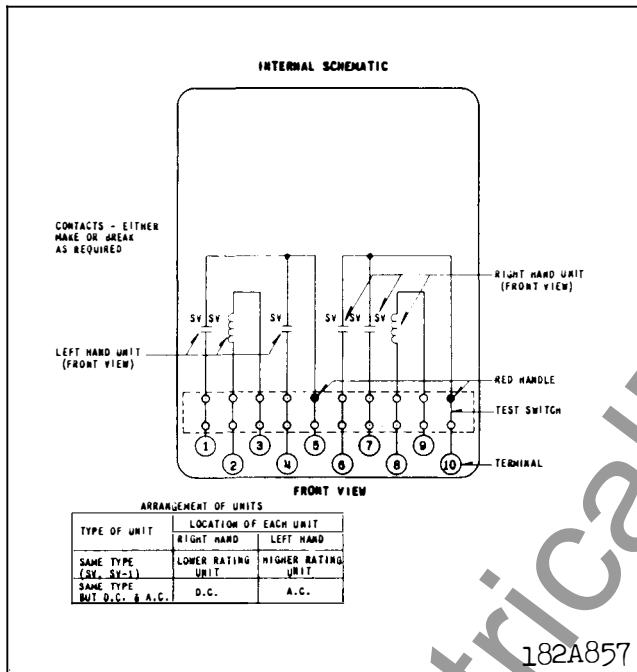

Fig. 5. Internal Schematic of the Double Unit Type SV or SV-1 Relay in the Type FT32 Case.

The shaft and plunger assembly should be handled carefully to avoid bending the shaft or damaging the bearing surfaces. The shaft should never be gripped on its upper bearing surface, below the spool-shaped bushing, when loosening the nut and setscrew, as this would almost certainly damage the bearing surface. The shaft bearing surfaces should not be cleaned or polished with any abrasive material, as the abrasive particles might become imbedded in the shaft and cause difficulty later. The plunger shaft and bearings may be cleaned by wiping them carefully with a clean, lint-less cloth. This may be moistened with benzene or some other cleaning solvent if necessary. Use no lubricant on the plunger shaft or bearings when re-assembling the relay, since this

will eventually become gummy and prevent proper operation. It is recommended that the shaft be clean-

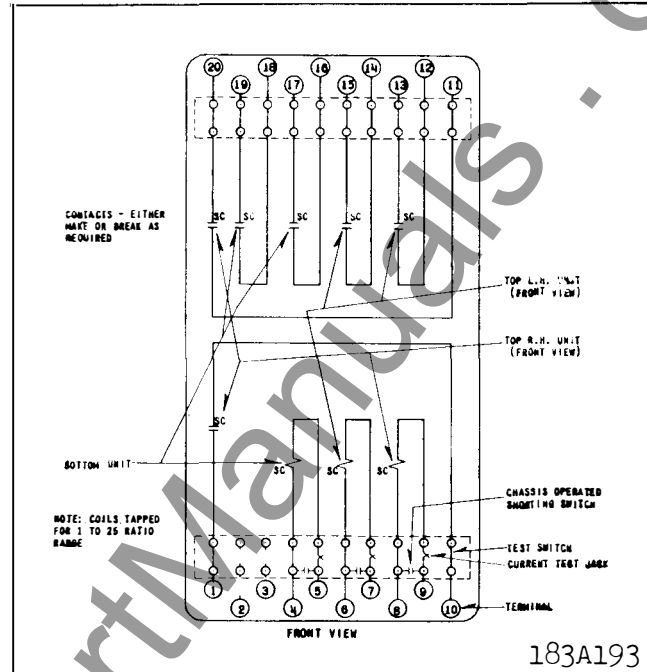

Fig. 6. Internal Schematic of the Three Unit Type SC or SC-1 Relay in the Type FT32 Case.

ed at intervals of approximately two years. When replacing the lower bearing and the split sleeves, the shorter sleeve (assembled below the bearing) should be pushed in until it is flush with the end of the threaded tube.

The mounting holes in the operation indicator screen are slotted so that its position can be adjusted. For relays in which the moving contacts are not latched in the operated position, the screen should be so located that the indicator positively enters the screen opening when the contacts barely touch. For latch-type relays, the screen should be so located that good contact is still obtained when the relay is de-energized. The pressure of the screen against the indicator may be adjusted by bending the screen between its lower end and the large elongated hole. This pressure should be such that the indicator will be held at any further position to which it is moved after entering the screen opening. However, the minimum amount of pressure necessary to obtain this adjustment should not be exceeded appreciably, since the pick-up value, and consequently the ratio, will be affected. The purpose of this pressure is to eliminate indicator rattle which might otherwise occur under certain energized conditions.

The moving contact leads pass through insulation sleeves assembled on the shanks of the terminal clips

CHARACTERISTICS OF TYPES SC AND SC-1 RELAYS

Type	Frequency	Range of Adjustment Amps.	Max. Amps. Continuous	Watts 5 Amps. 60 Cycles	V.A. at 5 Amps. 60 Cycles	Dropout Ratio-AC	Dropout Ratio-DC
SC	DC, 25 to 60 hz.	.5-2	1.5	99	225	90-98%	65-80%
SC	DC, 25 to 60 hz.	1-4	3	28	65	90-98%	65-80%
SC	DC, 25 to 60 hz.	2-8	6	6.9	19	90-98%	65-80%
SC	DC, 25 to 60 hz.	4-16	12	1.5	5	90-98%	65-80%
SC	DC, 25 to 60 hz.	10-40	25	.24	.7	90-98%	65-80%
SC	DC, 25 to 60 hz.	20-80	40	.07	.16	90-98%	65-80%
SC	DC, 25 to 60 hz.	40-160	40	.03	.05	90-98%	65-80%
SC	DC, 25 to 60 hz.	4-100*	10-15-20	1.7-0.6-0.18	5-1-0.2	90-98%	65-80%
SC-1	DC, 25 to 60 hz.	.5-2	1.5	100	210	35-60%	25-40%
SC-1	DC, 25 to 60 hz.	1-4	3	24	60	35-60%	25-40%
SC-1	DC, 25 to 60 hz.	2-8	6	6	16	35-60%	25-40%
SC-1	DC, 25 to 60 hz.	4-16	12	1.5	5	35-60%	25-40%
SC-1	DC, 25 to 60 hz.	10-40	25	.25	.65	35-60%	25-40%
SC-1	DC, 25 to 60 hz.	20-80	40	.07	.16	35-60%	25-40%
SC-1	DC, 25 to 60 hz.	40-160	40	.03	.05	35-60%	25-40%
SC-1	DC, 25 to 60 hz.	4-100*	10-15-20	1.7-0.6-0.18	5-1-0.2	35-60%	25-40%

* Coil has taps on which minimum pickups are 10 and 30 amperes.

CHARACTERISTICS OF SV AND SV-1 RELAYS

Type	Frequency (Cycles)	Range of Adjustment Volts	Max. Volts Continuous	Watts at 115 V. AC (125 V. for DC)	V.A. at 115 V.	Dropout Ratio
SV	60	7-16	16	-	-	90-98%
SV	60	70-160	160	3.4	7.3	90-98%
SV	60	140-320	320	-	-	90-98%
SV	60	280-640	640	-	-	90-98%
SV	50	70-160	180	2.8	6.1	90-98%
SV	25	70-160	200	1.5	2.5	90-98%
SV	DC	50-150	150	4.8	-	65-80%
SV	DC	100-300	300	-	-	65-80%
SV-1	60	7-16	16	-	-	40-80%
SV-1	60	70-160	160	4.1	8.5	40-80%
SV-1	60	140-320	320	-	-	40-80%
SV-1	60	280-640	640	-	-	40-80%
SV-1	50	70-160	180	3.5	7.1	40-80%
SV-1	25	70-160	200	1.4	3.2	40-80%
SV-1	DC	50-150	150	4.8	-	25-40%
SV-1	DC	100-300	300	-	-	25-40%

NOTES:--Standard current relays are calibrated on 60 hertz. This calibration is approximately correct for 25 cycle and dc applications, but there will be discrepancies of 10% to 15% at some points of scale.

Values of watts and volt-amperes in the tables are average for various plunger and shunt position.

For the SC relay, volt-amperes for pickup at minimum setting are approximately 3.4 and 1.4 for 60 and 25 cycles. Watts at minimum setting are approximately 1.0, .65 and .57 for 60 hertz, 25 hertz and DC respectively. Multiply values by 16 for approximate burdens at maximum setting.

For the SC-1 relay, volt-amperes for pickup at minimum setting are approximately 3.5 and 1.3 for 60 and 25 cycles. Watts at minimum settings are 1.3, .7 and .57 for 60 hertz, 25 hertz and dc respectively. Multiply values by 16 for approximate burdens at maximum setting.

*The V.A. burdens of the SC and SC-1 relays at 3, 10 and 20 times minimum pickup current are approximately 31, 240 and 770 V.A. respectively.

Dropout ratio varies somewhat with pickup adjustment but will be approximately constant for any given pickup setting. Limits in tables include variables such as friction and other individual relay variations.

Maximum continuous volts given for the SV and SV-1 relays for ac are for the relay set for minimum pickup. With the relay set for maximum pickup the continuous voltage can be increased 10 to 20%.

TYPES SC, SC-1, SV AND SV-1 RELAYS

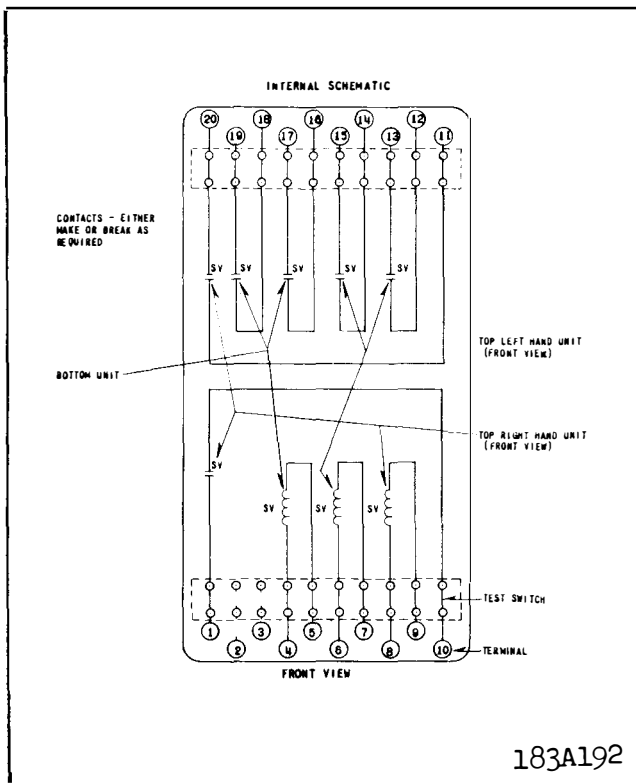

Fig. 7. Internal Schematic of the Three Unit Type SV or SV-1 Relay in the Type FT32 Case.

which are attached to the base terminals. These sleeves are notched at their upper ends, and the notches are toward the center of the relay. The leads are bent at approximately a right angle where they pass out through the notches, which aids in preventing them from coming into contact with the stationary contact brackets. Figure 11 shows properly coiled and assembled moving contact leads.

Although the moving contact leads are very flexible, if the leads have been pulled out of their original shape by handling they may exert sufficient side pressure on the shaft bearing or twisting force against the guide post to cause appreciable friction and wear. If this condition continues for a long period of time, the resulting wear may affect the relay calibration or the dropout ratio noticeably. In extreme cases the wear may progress to a degree which may occasionally cause failure of the plunger to drop down when the relay is de-energized.

Correct shaping of the leads is not difficult, and they may be checked readily by removing the guide post and the nut at the top of the shaft. The plunger should be held in the raised position, either by energizing the relay or by pressing lightly against the

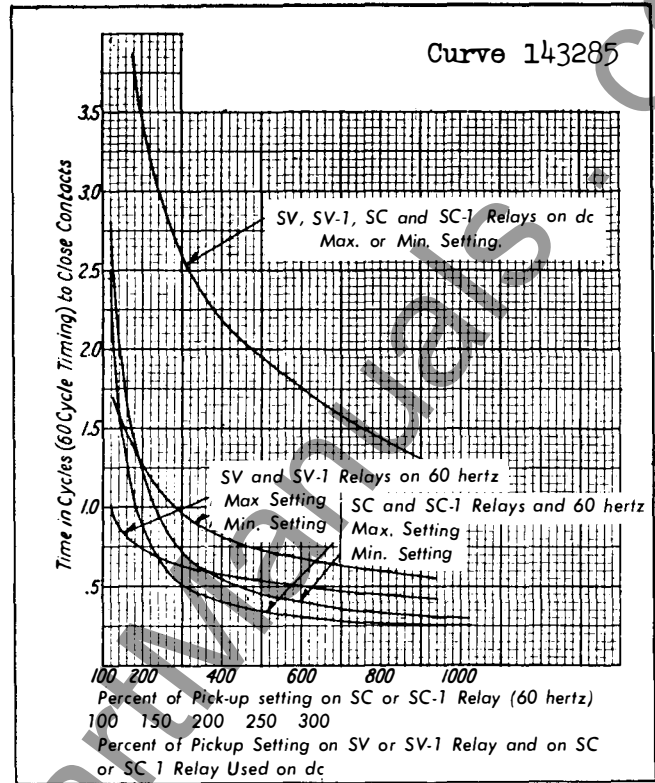

Fig. 8. Typical Time Curves for the Types SC and SV Relays (Using Flux Shunt for Pick-up Adjustment.)

collar under the insulation plate after raising the plunger manually. With the plunger raised, the insulation plate should be oscillated slightly in a horizontal plane by twisting it horizontally and releasing it. If in several trials the plate comes to rest with the center line of the contacts approximately parallel to the base and with its mounting hole fairly well centered with the end of the shaft, if the plate does not tip appreciably, and if the leads have a safe clearance to the stationary contact brackets, the leads are properly shaped.

If this check shows that re-shaping is necessary, it may be possible to obtain sufficient correction by bending the leads sharply where they emerge from the insulation sleeves. One or two pairs of tweezers are tools for re-shaping the leads. If it is necessary to re-coil the leads, they should be wound around a rod having a diameter of approximately $5/32''$. The coils then should be stretched out just enough to avoid side pull or twisting force on the plunger assembly.

In all relays except the SV-1 relay for ac, if the stationary contacts are assembled so that they close when the relay is energized, they should be located so that they barely touch the moving contacts when

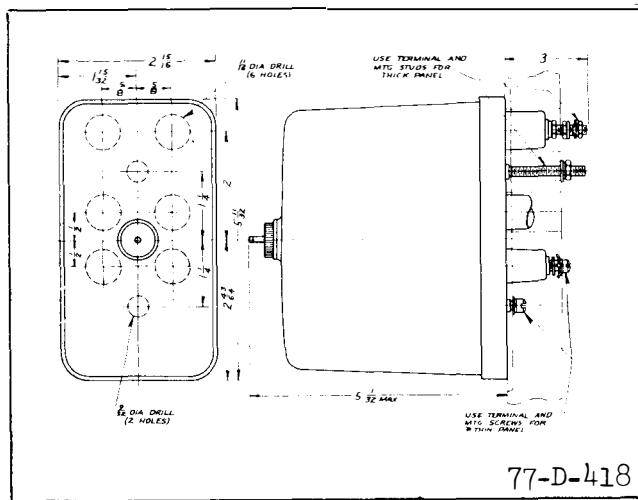

Fig. 9. Outline & Drilling Plan for Single Unit Relays in Small Glass Projection Case.

the latter are 5/32" above the de-energized position. The moving contacts can be held in this position while the adjustment is being made by inserting a 5/32" spacer between the shaft collar and the top of the core. This dimension should be 3/16" on the SV-1 relay for ac. Both contacts should touch at the same time when the plunger is raised. When the plunger is moved upward against its stop, there should be a slight deflection of the stationary contact stop springs, but this should not exceed 1/32". When the stationary contacts are reversed so that they are closed when the relay is de-energized, they should be located so that they just touch the moving contacts when the latter are 1/32" above the de-energized position. On some relays it may be found that when the contacts are used in this position the relay may operate at values a few percent below the scale markings. The adjustments specified for the stationary contacts are important. Failure to observe them may cause improper relay operation, either directly or after a period of service. Contact position should not be used as a means of altering the ratio of dropout to pickup.

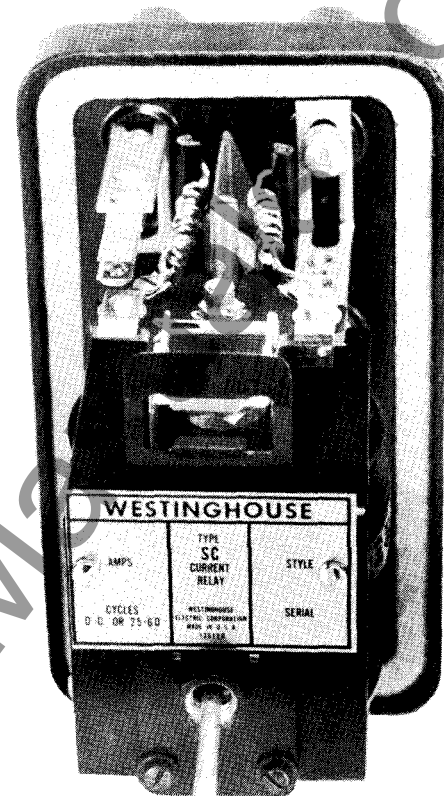

Fig. 10. View of Type SC Relay Showing Correct Shaping of Moving Contact Leads.

RENEWAL PARTS

Repair work can be done most satisfactorily at the factory. However, interchangeable parts can be furnished to the customers who are equipped for doing repair work. When ordering parts, always give the complete nameplate data.

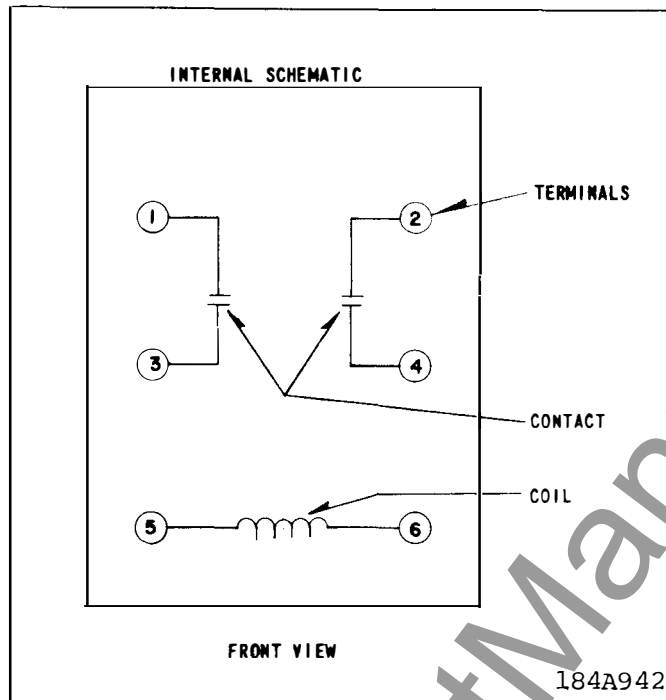

Fig. 11. Internal Schematic for Relays in Front Connected Case.

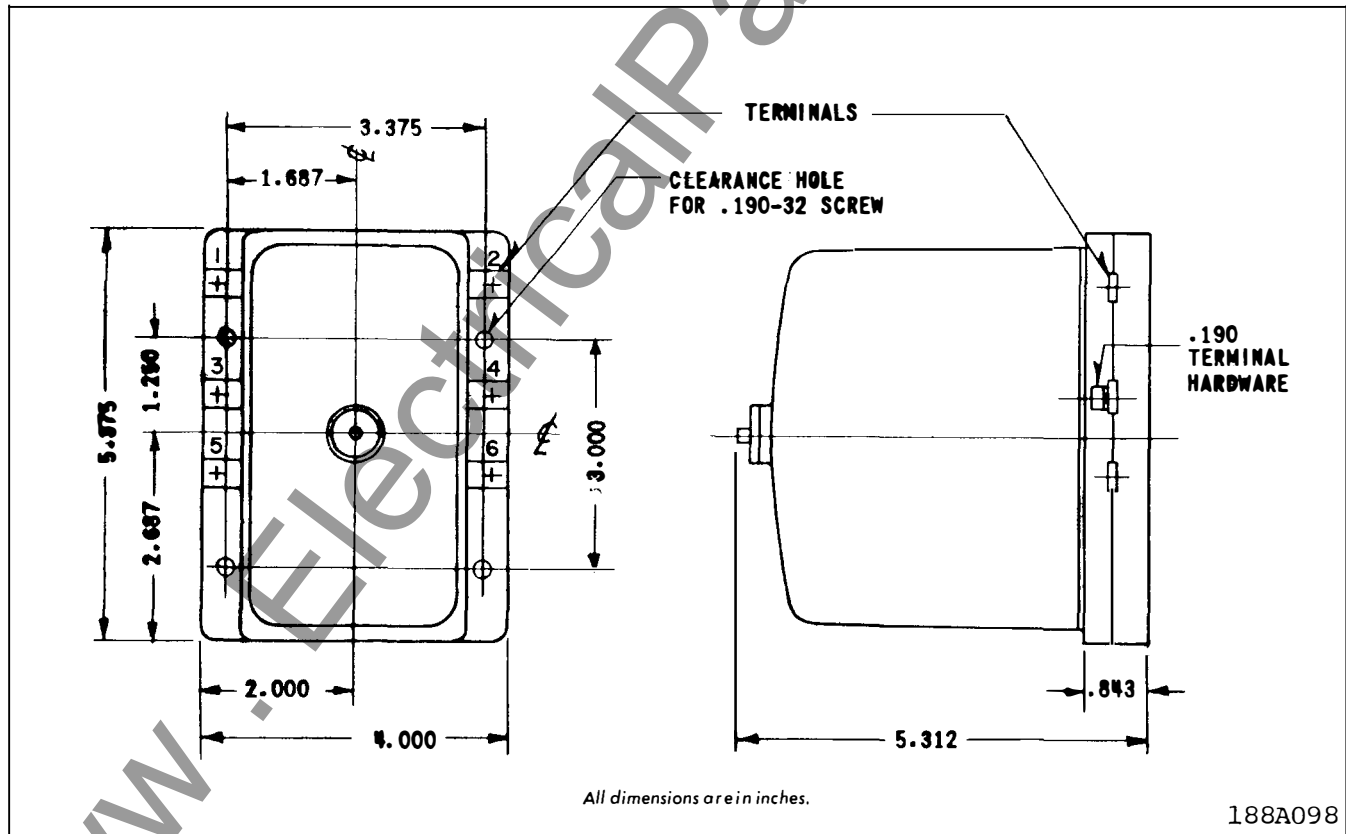

Fig. 12. Outline and Drilling Plan for Relays in Front Connected Case.

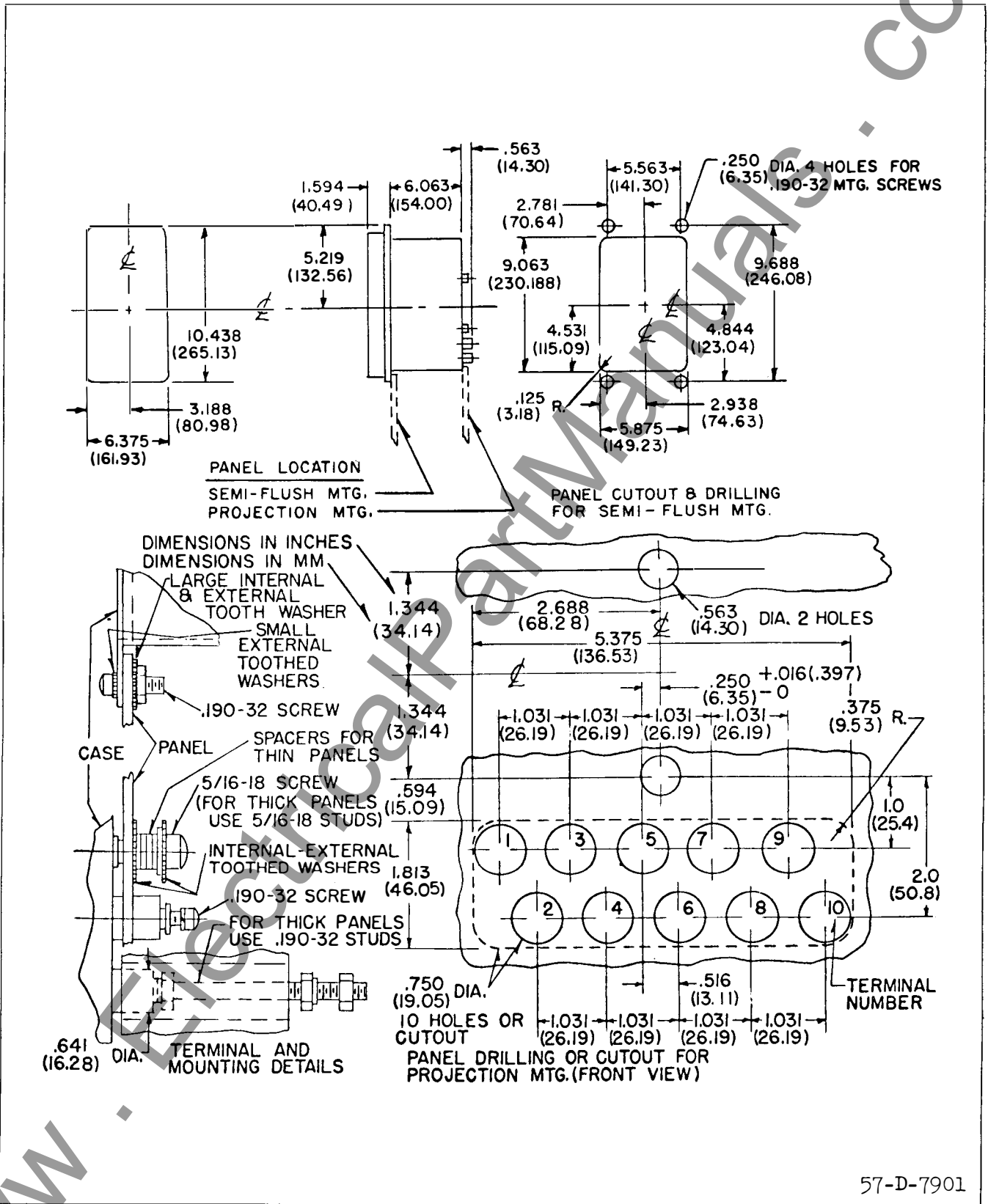

Fig. 13 Outline and Drilling Plan for Single and Double Unit Relays in the Type FT21 Case.

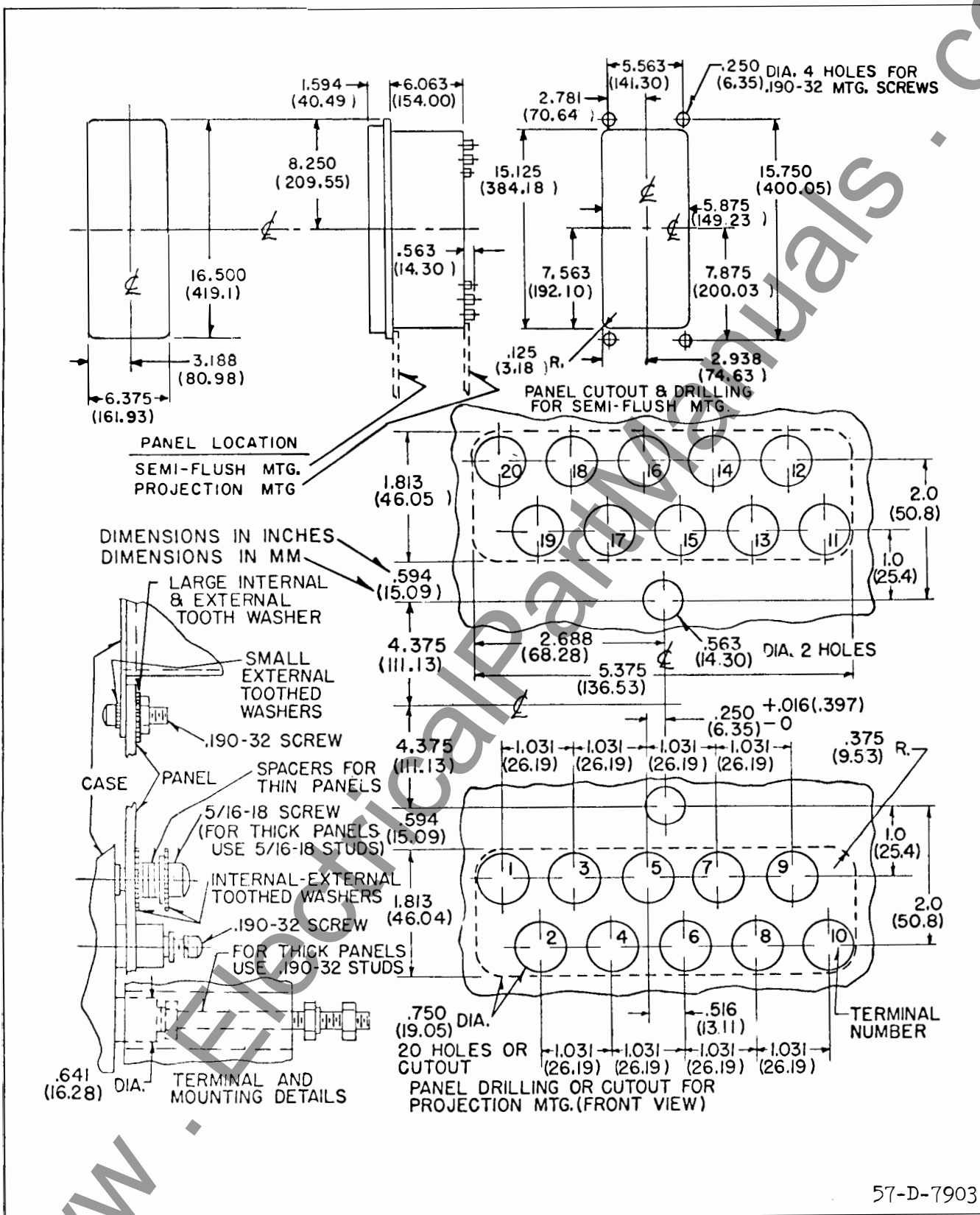

Fig. 14. Outline and Drilling Plan for Three Unit Relays in the Type FT32 Case.

www.ElectricalPartManuals.com



WESTINGHOUSE ELECTRIC CORPORATION
RELAY-INSTRUMENT DIVISION

CORAL SPRINGS, FL.

Printed in U.S.A.

**INSTALLATION • OPERATION • MAINTENANCE
I N S T R U C T I O N S****TYPES SVF, SVF-1, SVF-3, SVF-31 RELAYS
CONSTANT DROPOUT OR PICKUP VOLTAGE
VALUE FROM 20 TO 60 HERTZ**

CAUTION: Before putting protective relays into service, remove all blocking which may have been inserted for the purpose of securing the parts during shipment, make sure that all moving parts operate freely, inspect the contacts to see that they are clean and close properly, and operate the relay to check the settings and electrical connections.

APPLICATION

Where dropout independent of frequency is required, the SVF and SVF-1 instantaneous undervoltage relays are recommended. Dropout is adjustable over the range of 24-36 and 30-45 volts for the SVF-1 and SVF relays respectively with a maximum dropout variation of $\pm 5\%$ between 20 and 60 hertz. Where the relay is required to operate only during balanced 3 phase conditions, the single phase SVF or SVF-1 is suitable. Where balanced conditions may not exist when relay operation is required, the 3 phase relay design type SVF-3 or SVF-31 is recommended.

For supervising initiation of bus transfer, where the undervoltage relay is measuring the residual voltage of the motor load, the 3 phase SVF-3 or SVF-31 is recommended, since one or more phase voltages may be reduced by a fault on the supply circuit prior to transfer.

CONTENTS

This IL covers the following four types of relays: SVF, SVF-1, SVF-3 and SVF-31.

1. SVF is a single phase relay with a dropout voltage value adjustable from 30 to 45 volts for a relay rated 120 volts.
2. SVF-1 is a single phase relay with a dropout voltage value adjustable from 24 to 36 volts for a relay rated 120 volts.
3. SVF or SVF-1 relays with a pickup voltage adjustable from 50 to 150 volts are also covered.
4. SVF-3 is a three phase relay with a dropout voltage value adjustable from 30 to 45 volts phase to phase, for the relay rated 120 volts.
5. SVF-31 is a three phase relay with a dropout voltage value adjustable from 18 to 30 volts phase to phase, for the relay rated 120 volts.
6. SVF-3 or SVF-31 relays with a pickup voltage value adjustable from 50 to 150 volts are also covered.
7. Relays with rated voltage other than 120 volts will have dropout ranges proportioned to the 120 volt values.

CONSTRUCTION AND OPERATION**RELAYS**

The single phase SVF and SVF-1 relays consist of an SV or SV-1 voltage unit respectively, a reactor, a series resistor and a full wave rectifier. The resistor and reactor are proportioned to maintain a constant effective ampere turn to the SV or SV-1 from 20 to 60 hertz.

The three phase SVF-3 and SVF-31 relays consist of an SV or SV-1 voltage unit respectively,

All possible contingencies which may arise during installation, operation, or maintenance, and all details and variations of this equipment do not purport to be covered by these instructions. If further information is desired by purchaser regarding his particular installation, operation or maintenance of his equipment, the local Westinghouse Electric Corporation representative should be contacted.

three external series resistors, three full wave bridge rectifiers, and two capacitors. The full wave bridges plus the filter capacitors provide a steady dc voltage to the SV or SV-1 unit of the relay from 20 to 60 hertz.

VOLTAGE UNIT (SV OR SV-1)

The types SV and SV-1 voltage units operate on the solenoid principle. A U-shaped iron frame, mounted on the moulded base supports the coil and serves as the external magnetic path for the coil.

The coil surrounds a core and flux shunt, the upper end of the core is threaded and projects through the upper side of the frame to which it is fastened by a nut. A tube threaded on the outside at its lower end is assembled in the core, and the threaded ends extends below the core. A Fluorosint† bushing, which is the lower bearing for the plunger shaft, is assembled in the lower end of this threaded tube. It is held in place by two split spring sleeves, one above and one below the bearing. The split sleeves must be compressed to insert them in the tube and they will remain at any position in which they are placed. The bearing for the upper end of the plunger shaft is a Fluorosint† bushing which is pressed in the upper end of the core. This bearing is visible when the plunger is in the energized position. The plunger itself does not touch the walls of the tube in which it moves.

A flux shunt which surrounds the core is screwed on the tube, and its lower end projects below the relay frame. The position of this shunt determines the dropout setting of the relay. The lower end of the shunt is beveled and knurled, so that it can be grasped by the fingers and turned to change the setting. A calibrated scale plate is mounted adjacent to the shunt. A groove just above the knurl in the lower end of the shunt serves as an index mark, and the relay pick-up setting is indicated by the calibration scale marking which is adjacent to the groove.

The construction of the plunger, core and flux shunt (which differ in details in the various types of these relays) causes the plunger to float in its energized position without being held against a stop.

The shunt is held in any desired position by pressure from a curved arm made of sheet spring

steel, which is fastened to the bottom of the coil frame at the rear of the shunt. This spring arm is shaped to extend around the shunt to the front of the relay, and in its normal position it exerts sufficient pressure against the shunt to prevent any creeping of the shunt or undesired change of setting. The front end of the spring arm has a bent-over tab on which thumb pressure may be applied to move the arm out of contact with the shunt while the position of the latter is being changed.

The stationary contacts are assembled on slotted brackets. These are held in position on the base by filister-head screws which are threaded into the terminal inserts. Lock washers are assembled inside the moulded terminal bushings between the inserts and the base as a safeguard against loosening of the screws. By rotating the bracket on its mounting screw and moving it along its slot, the contact assembly can be made either normally closed or normally open. The moving contacts are mounted on a Micarta insulation plate which is secured to the threaded end of the plunger shaft by a nut. The rear portion of the plate is slotted and a post screwed to the frame passes through this slot to prevent the plate from rotating. The moving contacts are double-faced so that they can be "make" or "break" and are connected to the base terminals by flexible leads. All contacts are pure silver.

CHARACTERISTICS AND SETTINGS

The types SVF and SVF-1 single phase and SVF-3 and SVF-31 three phase relays are supplied with dropout voltages constant between 20 and 60 hertz, and have a scale calibrated in dropout volts. See Table 1. These relays are designed for operation on a supply having a nominal value of 120 volts. The scale markings were determined by reducing the voltage gradually from 120 volts. The characteristics of the relays are such that at any setting, the relay will drop out at the same value of voltage (within 5%) for any frequency between 20 and 60 hertz. The pickup voltages will vary somewhat on various relays.

The insensitivity of the single phase relays to frequency is obtained primarily by operating the voltage unit on full-wave rectified ac. To compensate for the tendency of the voltage unit to res-

†Trademark of the Polymer Corporation

TABLE I

Relay	120 Volt Relay Dropout Voltage Range $\pm 5\%$	Typical Pickup Values Less Than	Typical Operate Time ¹ ms	Typical Reset Time ² ms	Burden ³ Per Phase Volt Amps
SVF	30-45	75	10	70	60 Hz 17 / 27° lag 25 Hz 18.5
SVF-1	24-36	75	10	70	60 Hz 17 / 27° lag 25 Hz 18.5
SVF-3	30-45	95	15-25	75-60	4.9 / 0°
SVF-31	18-30	100	15-25	75-60	4.9 / 0°

¹Time to open the normally closed contacts.

²Time to close the normally closed contacts.

³Values of volt-amperes are average for various plunger and shunt positions.

pond to instantaneous voltage values and, therefore, to drop out at higher rms voltages as the frequency decreases, a reactor is used in the ac circuit. The effect of the reactor is to cause the rectified current to increase slightly as the frequency decreases, thus keeping the dropout point at approximately the same rms voltage value throughout the frequency range. The series resistor in the ac supply renders negligible the effect of the relay coil temperature on the operating point. Because of residual magnetism, when the voltage is reduced from 120 volts, the dropout point may be slightly higher than it is when reduced from the pickup values.

INSTALLATION

The relays should be mounted on switchboard panels or their equivalent in a location free from dirt, moisture, excessive vibration, and heat. Mount the relay vertically by means of the four mounting holes on the flange for semi-flush mounting or by means of the rear mounting stud or the mounting screws may be utilized for grounding the relay. The electrical connections may be made directly to the terminals by means of screws for steel panel mounting or to the terminal studs furnished with the relay for thick panel mounting. The terminal studs may be easily removed or inserted by locking two nuts on the stud and then turning the proper nut with a wrench.

For detailed FT case information refer to I.L. 41-076.

ADJUSTMENTS AND MAINTENANCE

The proper adjustments to insure correct operation of this relay have been made at the factory and should not be disturbed after receipt by the customer. If the adjustments have been changed, the relay taken apart for repairs, or if it is desired to check the adjustments at regular maintenance periods, the instructions below should be followed.

All contacts should be cleaned periodically. A contact burnisher S #182A836H01 is recommended for this purpose. The use of abrasive material for cleaning contacts is not recommended, because of the danger of embedding small particles in the face of the soft silver and thus impairing the contact.

SV UNIT CHECK AND MAINTENANCE

Several factors may affect the dropout ratio of the relay. The factor most likely to be encountered in service is friction. This may be due to dirt or foreign material between the plunger shaft and its bearings, or to leads so misshaped that they tend

to rotate or tilt the moving contact insulation plate with appreciable force.

In order to remove the plunger and shaft assembly, it is necessary to remove the set-screw and nut at the top of the shaft. The spool-shaped bushing assembled on the upper end of the plunger shaft has a portion of its center section machined off so that the shaft is exposed at this point and can be prevented from turning by gripping shaft and bushing with a pair of longnose pliers while removing the set screw and nut. Then by pressing down with the fingers on the upper end of the shaft, the lower split sleeve which retains the lower bearing will be forced out of the threaded tube, the bearing will drop out freely, and the upper split sleeve will be forced out far enough to permit grasping it for removal. The shaft and plunger assembly then can be removed.

The shaft bearing surfaces should not be cleaned or polished with any abrasive material, as the abrasive particles might become imbedded in the shaft and cause difficulty later. The plunger shaft and bearings may be cleaned by wiping them carefully with a clean, lintless cloth. This may be moistened with benzene or some other cleaning solvent if necessary. Use no lubricant on the plunger shaft or bearings when reassembling the relay, since this will eventually become gummy and prevent proper operation. It is recommended that the shaft be cleaned at intervals of approximately two years. When replacing the lower bearing and the split sleeves, the shorter sleeve (assembled below the bearing) should be pushed in until it is flush with the end of the threaded tube.

The moving contact leads pass through insulation sleeves assembled on the shanks of the terminal clips which are attached to the base terminals. These sleeves are notched at their upper ends, and the notches are toward the center of the relay. The leads are bent at approximately a right angle where they pass out through the notches, which aids in preventing them from coming into contact with the stationary contact brackets.

Although the moving contact leads are very flexible, if the leads have been pulled out of their original shape by handling they may exert sufficient side pressure on the shaft bearing or

twisting force against the guide post to cause appreciable friction and wear. If this condition continues for a long period of time, the resulting wear may affect the relay calibration or the dropout ratio noticeably. In the extreme cases the wear may progress to a degree which may occasionally cause failure of the plunger to drop down when the relay is de-energized.

Correct shaping of the leads is not difficult, and they may be checked readily by removing the guide post and the nut at the top of the shaft. The plunger should be held in the raised position, either by energizing the relay or by pressing lightly against the collar under the insulation plate after raising the plunger manually. Release the plate and if in several trials the plate comes to rest with the center line of the contacts approximately parallel to the side of the base, its mounting hole fairly well centered, the plate not tip appreciably, and the leads have a safe clearance to the stationary contact brackets, the leads are properly shaped.

If this check shows that re-shaping is necessary, it may be possible to obtain sufficient correction by bending the leads sharply where they emerge from the insulation sleeves. One or two pairs of tweezers are convenient tools for re-shaping the leads. If it is necessary to re-coil the leads, they should be wound around a rod having a diameter of approximately $5/32$ ". The coils then should be stretched out just enough to avoid side pull or twisting force on the plunger assembly.

SV UNIT CONTACT SETTINGS. ALL RELAYS

The normally open contact gap should be set at $5/32$ ", and the follow (travel after contact closure) should be $1/32$ " maximum. The moving contact can be held in position by placing a $5/32$ " spacer between the shaft collar and the top of the core.

The normally closed contacts should have a $1/32$ " follow in the deenergized (reset) position. When normally open contacts are changed to normally closed, the pickup value may be changed by a few percent.

When the contacts are both normally open or both normally closed, an effort should be made to have both contacts make at the same time.

Contact position should not be used as a means of altering the ratio of dropout to pickup.

CALIBRATION

Use the following procedure for calibrating the relay if the relay has been taken apart for repairs or the adjustments disturbed. This procedure should not be used until it is apparent that the relay is not in proper working order.

SV UNIT ELECTRICAL CHECK

Apply dc voltage to the coil terminals.

- 1) For the single phase relay disconnect one lead from the rectifier bridge to the coil terminal and connect a variable dc voltage supply to the coil terminals.
- 2) For the three phase relay open the Flexitest switches and connect a variable dc voltage supply to terminals 9 and 6.

The SV unit shunt should be capable of a dc pickup adjustment of 11 volts minimum to 33 volts maximum. At 33 volts the dropout value should be greater than 10 volts and less than 14 volts for the SVF-1 and SVF-31 relays. At 33 volts the dropout value should be not less than 22 volts for the SVF and SVF-3 relays.

Reconnect all wires that have been removed.

RELAY CALIBRATION

CAUTION: If the three phase relay is being tested out of the case, the proper resistors per the schematic, must be connected into the circuit before proceeding.

SVF single phase relay. Set the index mark on the shunt to the 30 volt mark (approximately 3/4" below the frame). Apply 120 volts 60 hertz and adjust the resistor for a dropout value of 30 volts 60 hertz, (Approximately 500 ohms). Reduce the

voltage from 120 volts to the dropout value when checking the dropout setting. If a new scale is being calibrated, mark the 35, 40, and 45 volt points. The dropout value at 25 hertz should not vary more than 5% from the 60 hertz value.

The pickup value for the 45 volt setting must be less than 80 volts.

SVF-3 three phase relay. Apply 3 phase, 120 volts 60 hertz phase to phase to the relay case or to the relay with the appropriate resistors in series. Calibrate as per the single phase values for the SVF.

The pickup value for the 45 volt setting must be 96 volts ac or less.

SVF-1 single phase relay. Set the index mark on the shunt to the 24 volt mark, (Approximately 3/4" below the frame). Apply 120 volts 60 hertz and adjust the resistor for a dropout value of 24 volts 60 hertz, (Approximately 600 ohms). Reduce the voltage from 120 volts to the dropout value when checking the dropout setting. If a new scale is being calibrated, mark the 24, 30 and 36 volt points. The dropout value at 25 hertz should not vary more than 5% from the 60 hertz value.

The pickup value for the 36 volt setting must be less than 75 volts.

SVF-31 three phase relay. Apply 3 phase 120 volts 60 hertz, phase to phase, to the relay case or to the relay with the appropriate resistors in series. Check and calibrate for the 18, 24 and 30 volt dropout values.

The pickup value for the 30 volt setting must be 100 volts ac phase to phase or less.

RENEWAL PARTS

Repair work can be done most satisfactorily at the factory. However, interchangeable parts can be furnished to the customers who are equipped for doing repair work. When ordering parts, always give the complete nameplate data.

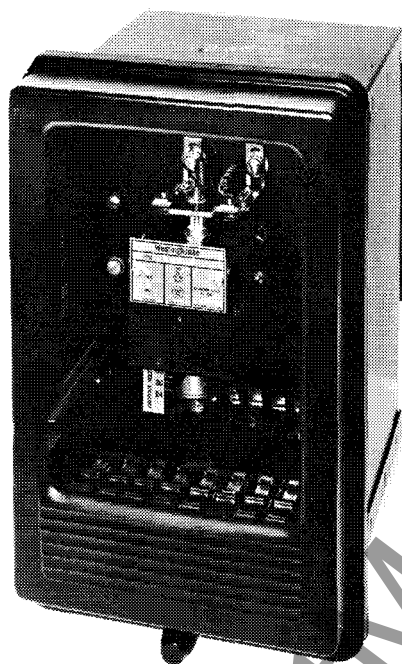

Fig. 1. Type SVF-31 Three Phase Relay (Front View)

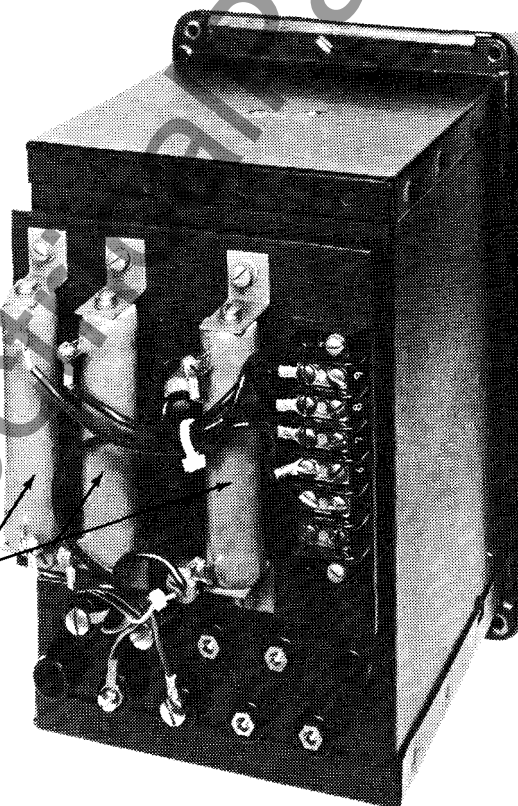

Fig. 2. Type SVF-31 Three Phase Relay (Rear View)

1-External Resistor Assembly

(Note: For Types SVF and SVF-1 Single Phase Relay a single resistor and reactor are mounted inside case.)

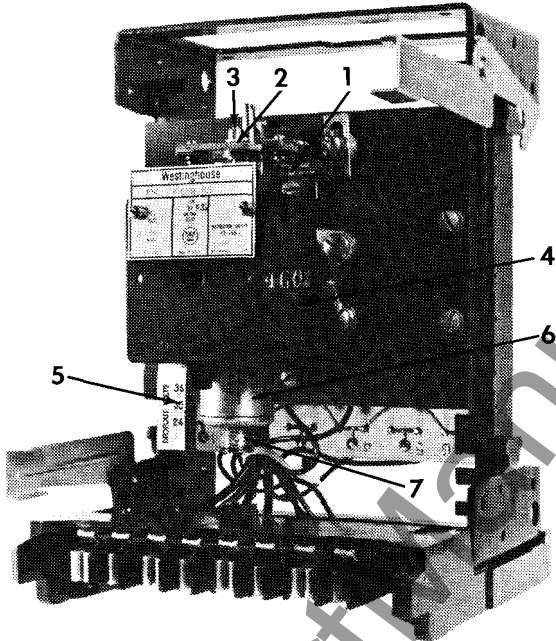

Fig. 3. Type SVF-31 Three Phase Relay without case (Front View)
1-Two independent reversible stationary contacts.
2-Moving Contact arm with two contacts.
3-Plunger.
4-Coil.
5-Calibrated Scale.
6-Adjustable Magnetic Shunt.
7-Core Screw.

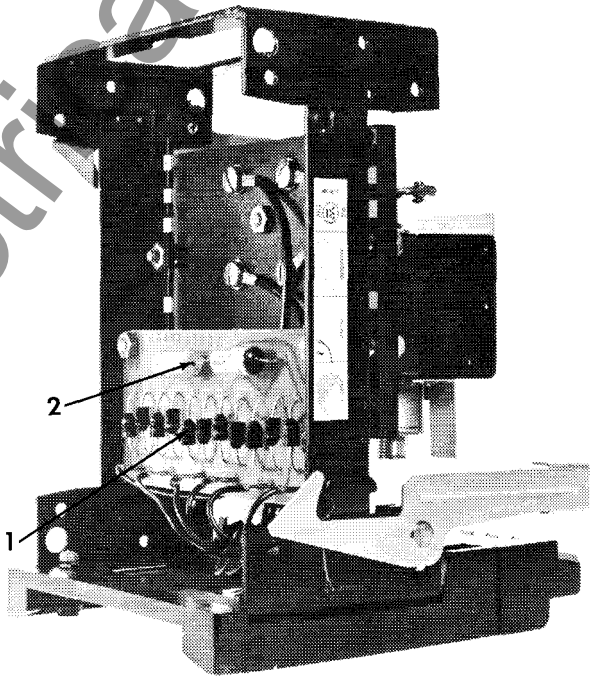

Fig. 4. Type SVF-31 Three Phase Relay without case (Rear View).
1-Diodes
2-Capacitor

TYPES SVF, SVF-1, SVF-3, SVF-31 RELAYS

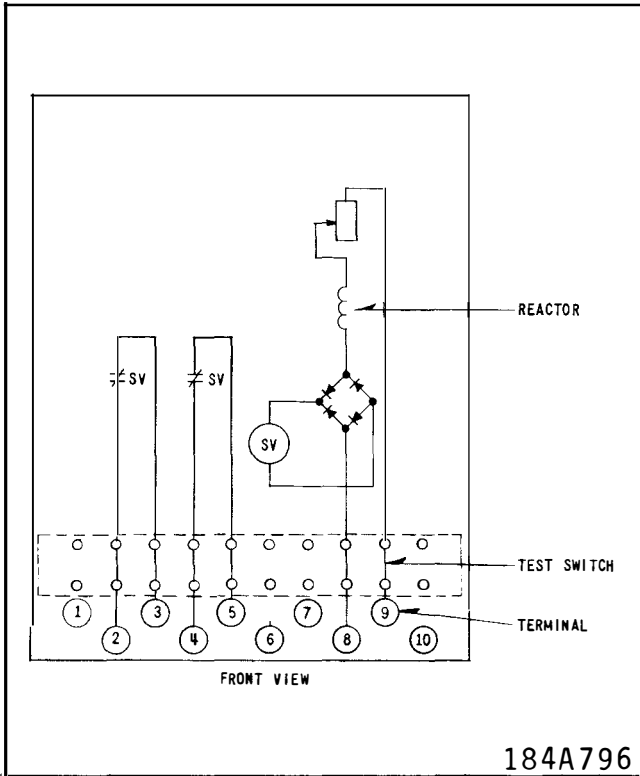

Fig. 5. Internal Schematic of the Type SVF and SVF-1 Under-voltage Single Phase Relays, with two circuit opening contacts without chassis shorting switches.

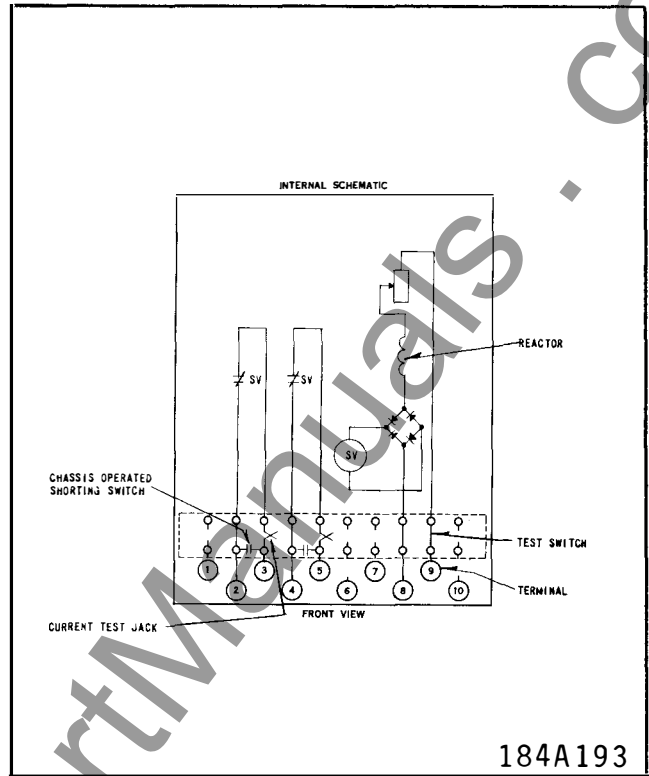

Fig. 6. Internal Schematic of the type SVF and SVF-1 Under-voltage Single Phase Relays, with two circuit opening contacts with chassis shorting switches.

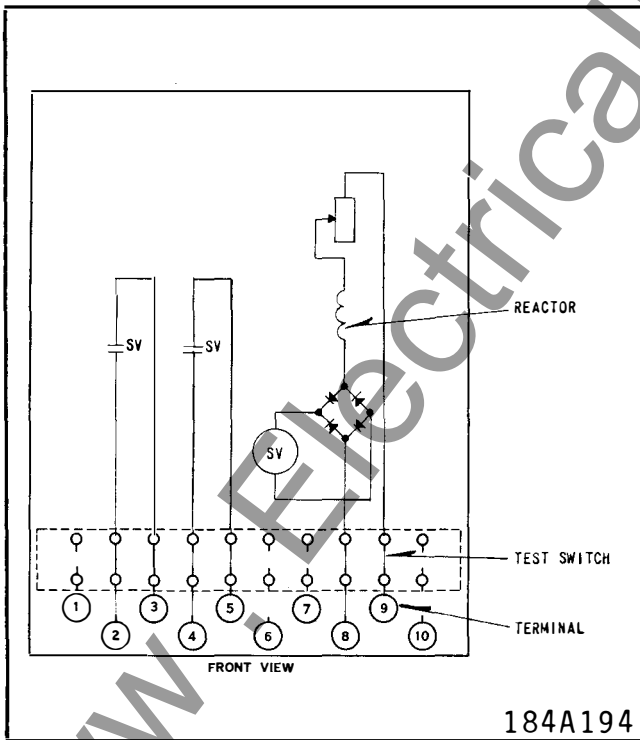

Fig. 7. Internal Schematic of the type SVF and SVF-1 Over-voltage Single Phase Relays, with two circuit closing contacts.

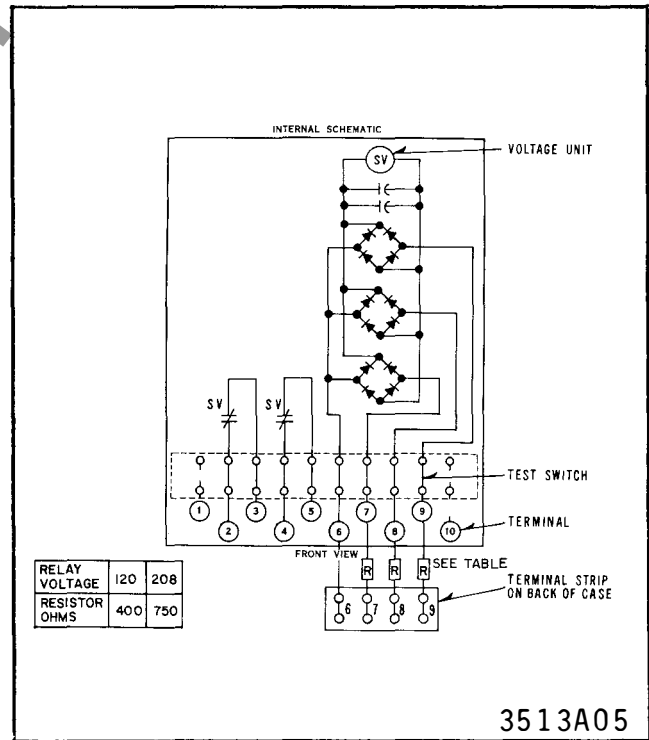

Fig. 8. Internal Schematic of the Type SVF and SVF-31 Under-voltage Three Phase Relays, with two circuit opening contacts without chassis shorting switches.

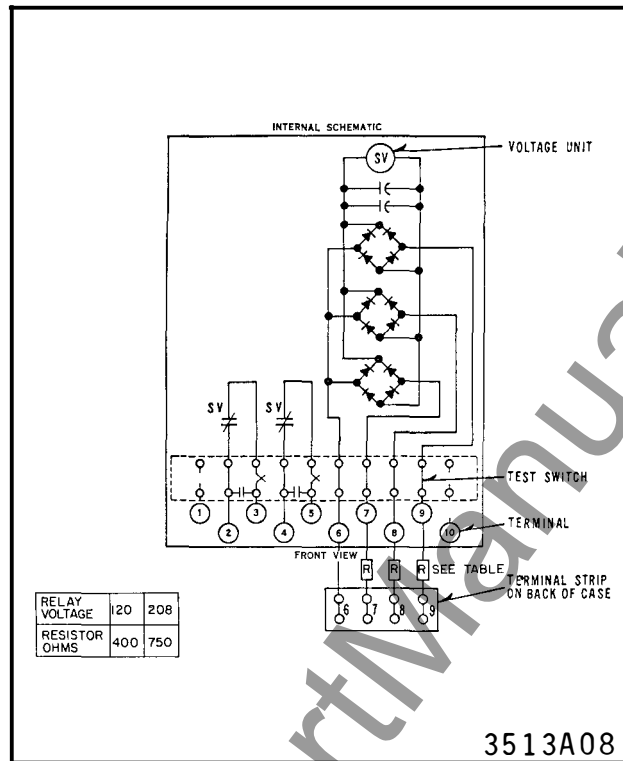

Fig. 9. Internal Schematic of the Type SVF-3 and SVF-31 Under-voltage Three Phase Relays, with two circuit contacts with chassis shorting switches.

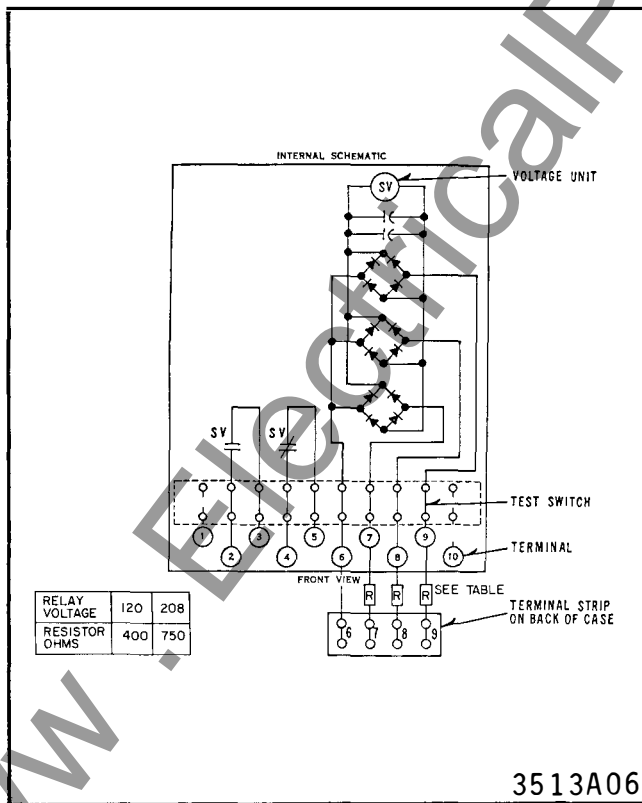

Fig. 10. Internal Schematic of the Type SVF-3 and SVF-31 Undervoltage Three Phase Relays, with one circuit opening and one circuit closing contact.

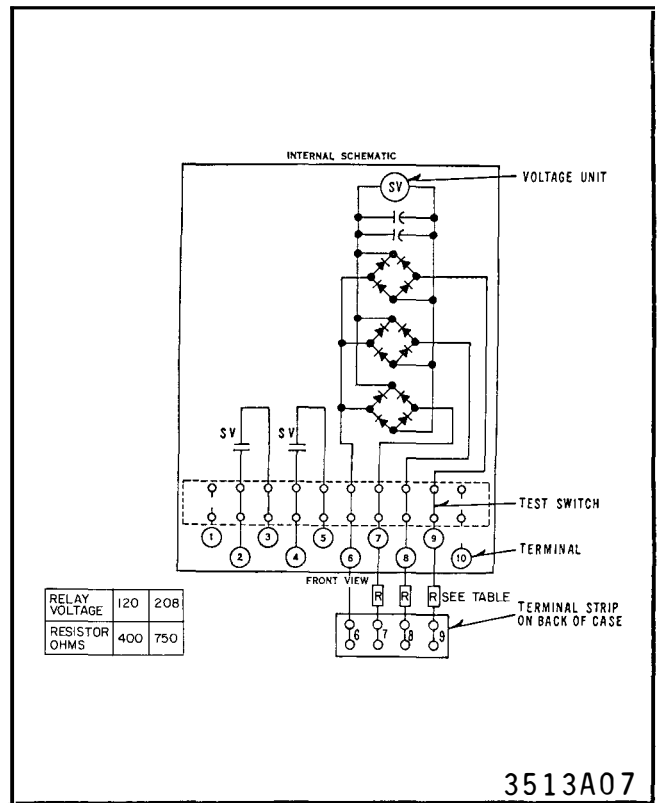
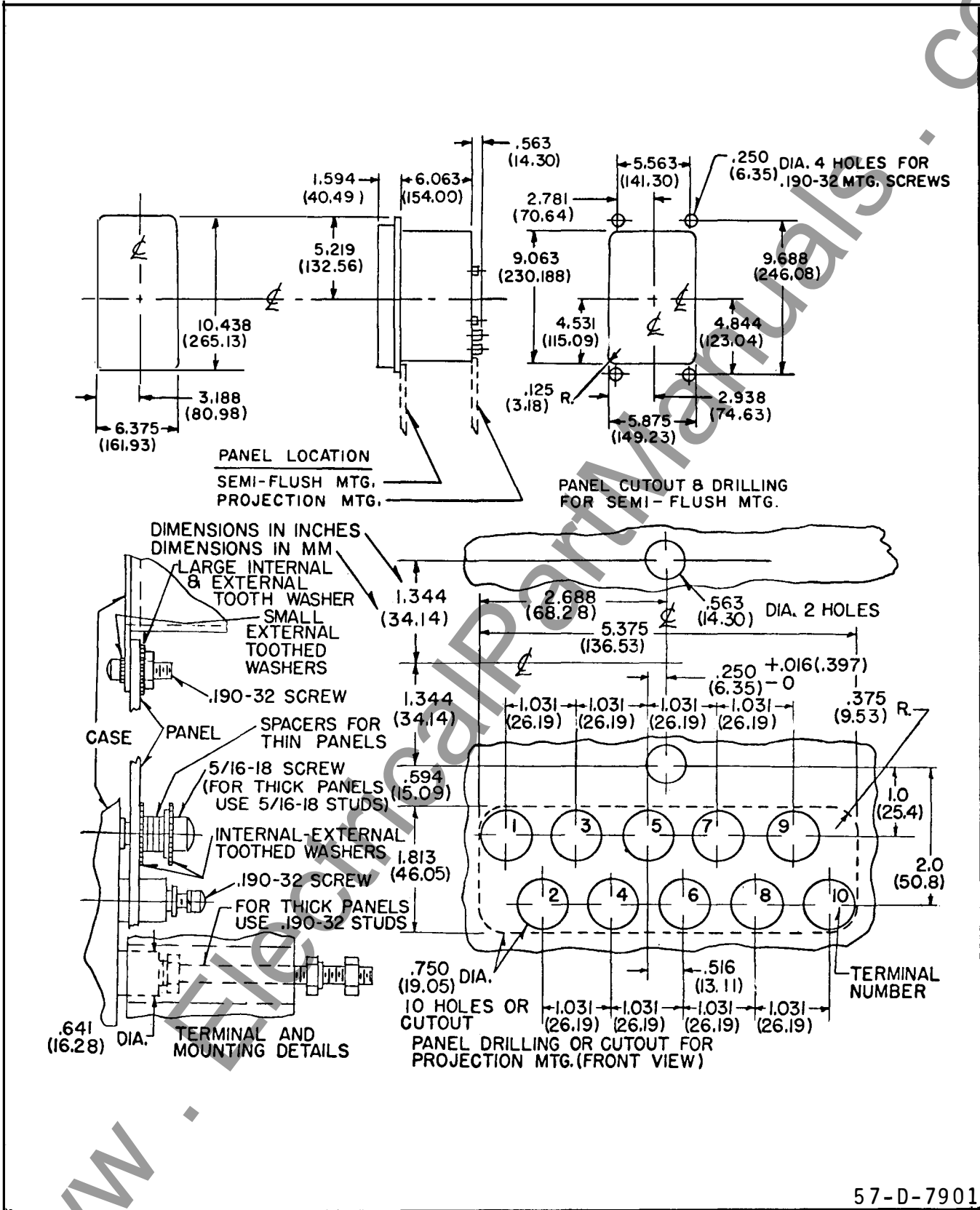

Fig. 11. Internal Schematic of the Type SVF-3 and SVF-31 Overvoltage Three Phase Relays, with two circuit closing contacts.



57-D-7901

Fig. 12. Outline and Drilling Plan for Type SVF and SVF-1 Single Phase Relays in Type FT 21 Case.

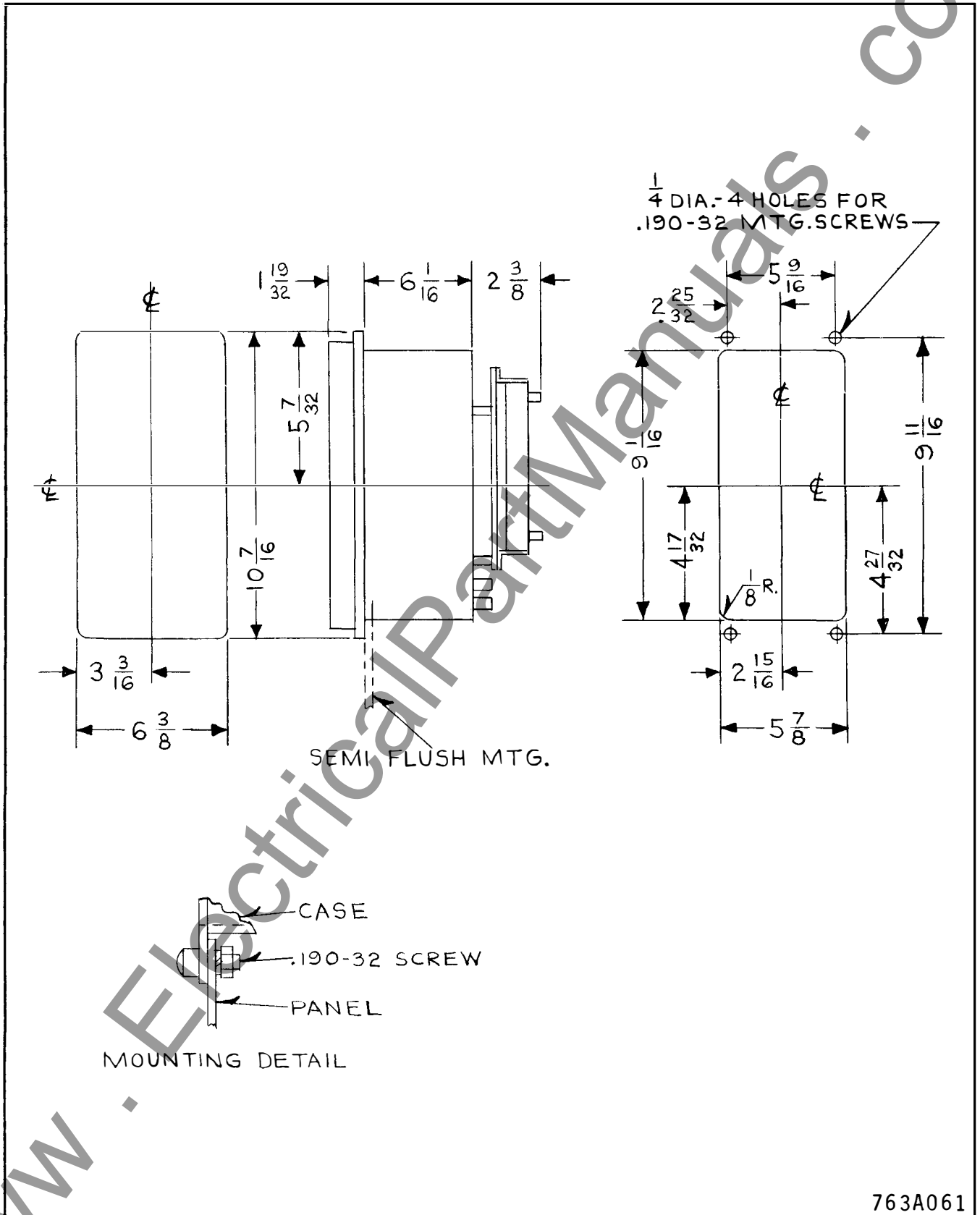
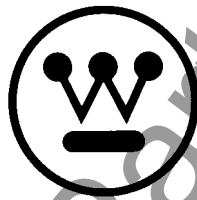

Fig. 13. Outline and Drilling Plan for Type SVF-3 and SVF-31 Three Phase Relays in Type FT 21 Case (Semi Flush Mounting.)



WESTINGHOUSE ELECTRIC CORPORATION
RELAY-INSTRUMENT DIVISION

CORAL SPRINGS, FL.

Printed in U.S.A.



ADDENDUM TO Westinghouse I.L. 41-766.5
INSTALLATION • OPERATION • MAINTENANCE
I N S T R U C T I O N S

**TYPES SSV-T AND SSC-T RELAYS
(For Class IE Application)**

This sheet notes changes which should be made in instruction leaflet I.L. 41-766.5 dated November 1977.

Page 4 - Paragraph at top of left column to be replaced by:

Indicating Contactor Switch (ICS)

Close the main relay contacts and pass sufficient dc current through the trip circuit to close the contacts of the ICS. This value of current should be not greater than ICS's rated current. The operation indicator target should drop freely.

The contact wipe should be approximately 0.016 inches. The bridging moving contact should touch both stationary contacts simultaneously.

All possible contingencies which may arise during installation, operation, or maintenance, and all details and variations of this equipment do not purport to be covered by these instructions. If further information is desired by purchaser regarding his particular installation, operation or maintenance of his equipment, the local Westinghouse Electric Corporation representative should be contacted.

www.ElectricalPartManuals.com

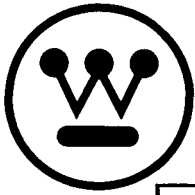
**INSTALLATION • OPERATION • MAINTENANCE
I N S T R U C T I O N S****TYPES SSV-T AND SSC-T RELAYS
(For Class IE Application)**

CAUTION: Before putting relays into service, remove all blocking which may have been inserted for the purpose of securing the parts during shipment. Make sure that all moving parts operate freely. Inspect the contacts to see that they are clean and close properly, and operate the relay to check the settings and electrical connections.

APPLICATION

These relays have been specially designed and tested to establish their suitability for Class IE applications. Materials have been selected and tested to insure that the relays will perform their intended function for their design life when operated in a normal environment as defined by ANSI standard C37.90 – 1971, when exposed to radiation levels up to 10^4 rads, and when subjected to seismic events producing a Shock Response Spectrum within the limits of the relay rating.

“Class IE” is the safety classification of the electric equipment and systems in nuclear power generating stations that are essential to emergency shutdown of the reactor, containment isolation, cooling of the reactor, and heat removal from the containment and reactor, or otherwise are essential in preventing significant release of radioactive material to the environment.

The solid state types SSC-T current relay and SSV-T voltage relay are high seismic relays and suitable for nuclear power station relaying protection. They are adjustable over a wide range of current and voltage and have a calibrated scale plate which indicates the pick-up setting. The output unit is a telephone relay and an ICS (Indicating Contactor Switch) seal-in device.

The type SSC-T and SSV-T relays have a high ratio of drop-out and are particularly suitable for use in applications requiring an accurate current or voltage level detector.

CONSTRUCTION

The type SSC-T or SSV-T relay consists of a printed circuit board with a transformer, a scale plate, an output telephone relay, and several associated components. The relay is mounted in the semi-flush FT-11 Flexitest case. The relay also includes one ICS (Indicating Contactor Switch) for indication and seal-in purposes. The relay chassis is draw-out construction for easy of test and maintenance.

The components are connected as shown in Fig. 4, 5, and 6.

Input Transformer – The input transformer is a two winding type with a center tapped secondary winding. The secondary is connected to two full wave rectifiers.

Rectifiers and DC Power Supply – There are two full wave rectifiers. One with two zener diodes and a capacitor is used as an input signal and connected to a level detector (setting) circuit. The zener diodes are also used as surge protections. The other full wave rectifier is used as dc power supply. For type SSC-T overcurrent relay, a resistor-zener diode is needed in order to keep the current transformer's linearity.

Setting Circuit – The setting circuit is connected between zener-rectifier and sensing circuit.

All possible contingencies which may arise during installation, operation, or maintenance, and all details and variations of this equipment do not purport to be covered by these instructions. If further information is desired by purchaser regarding his particular installation, operation or maintenance of his equipment, the local Westinghouse Electric Corporation representative should be contacted.

It consists of two resistors and a potentiometer with a scale plate. The potentiometer has a locking feature to minimize accidental change of setting.

Sensing Circuit – The sensing circuit consists of a transistor, a zener diode, and several associated components. It is actually a level detector. If the input voltage from the rectifier is high enough to break down the zener diode, the output transistor will be turned on.

Output circuit – The output circuit consists of a transistor driver and a telephone relay. The overcurrent relay (SSC-T) has a telephone relay equipped with 2-A type contacts. The over or under voltage relay (SSV-T) has a telephone relay equipped with 1-A & 1-B type contacts.

Indicating Contactor Switch (ICS) – The Indicating contactor switch is a small dc operated clapper type device. A magnetic armature to which leaf-spring mounted contacts are attached. It is attracted to the magnetic core upon energization of the switch. When the switch closes the moving contracts bridge two stationary contacts completing the trip circuit. Also during this operation, two fingers on the armature deflect a spring located on the front of the switch which allows the target to drop. The target is reset from the outside of the case by a push rod located at the bottom of the cover.

OPERATION

The block diagrams of the SSV-T and SSC-T are shown in Fig. 1, 2, and 3 and the internal schematic are shown in Fig. 4, 5, and 6. For overvoltage and overcurrent application, the transistor Q2 is normally not conducting and the telephone relay is deenergized. The transistor Q1 is used as an emitter follower. When ac voltage or current is applied to the primary of the transformer (T) a voltage is produced on the secondary side that is proportional to the input. The potentiometer (R2) is for the pick-up setting. If the voltage from rectifier (Z1, Z2, and C2) is large enough to exceed the breakdown voltage of zener diode Z5, the zener diode conducts to turn on the transistor Q2 and operate the telephone relay.

For undervoltage application, the transistors Q1 and Q2 are normally conducting and the telephone relay is pulled in. As soon as the input voltage drops below the setting, the transistor Q2 is turned off and the telephone relay is released.

CHARACTERISTICS

1. Overcurrent Relay SSC-T

Range	Continuous Rating
0.5 – 2 amps	2 amps
2.0 – 8 amps	8 amps
4.0 – 16 amps	10 amps
10 – 40 amps	10 amps
1 Second Rating:	28 times the continuous rating.
Operating Frequency:	50/60 Hz
Temperature Error:	2% between – 20°C and 65°C.
Dropout Ratio:	90% to 98%
Response Time:	Pickup Time = 10 – 13 ms Dropout Time = 10 – 26 ms For 2 to 15 times pickup setting value (Fig. 10)
Transient Overreach:	5%
Burden:	(Table I)
Frequency Response:	(Fig. 12)

TABLE I (60 hertz)

Range (Amps)	Pickup Current Setting			
	Lowest Setting		Highest Setting	
	VA	P.F. Angle ϕ	VA	P.F. Angle ϕ
0.5 – 2.0	0.5	8.5°	4.0	12.5°
2.0 – 8.0	0.5	8.5°	5.0	12.5°
4.0 – 16.0	0.5	8.5°	5.0	12.5°
10.0 – 40.0	0.8	10.0°	8.0	10.7°

2. Over/Under voltage Relay SSV-T.

Range: 60 – 140 Volts
 140 – 320 Volts
 280 – 640 Volts

Continuous Rating: Highest voltage of range setting.

Operating Frequency: 50/60 Hz.

Temperature Error: 2% between –20°C and +65°C

Dropout Ratio: 92% to 99%

Response Time: Pickup Time – 7 – 10 ms
 Dropout Time – 14 – 40 ms (Fig. 9)

Burden: 1 VA at 120 volts 60 hertz

Trip Circuit

The main contacts will safely close 30 amperes at 250 volts dc and the seal in contacts of the indicating contactor switch (when supplied) will safely carry this current long enough to trip a circuit breaker. The indicating contactor switch (when supplied) has a pickup of approximately 1 ampere. Its dc resistance is 0.37 ohms.

SETTINGS:

The relay must be set for the desired levels of voltage or current. The pickup of the relay is made by adjusting the potentiometer in the front of the

relay. Setting in between the scale marking can be made by applying the desired voltage or current and adjusting the potentiometer until the telephone relay operates.

INSTALLATION

The relays should be mounted on switchboard panels or their equivalent in a location free from dirt, moisture, excessive vibration and heat. Mount the relay vertically by means of the four mounting holes on the flange for the semi-flush type FT case. The mounting screws may be utilized for grounding the relay. External toothed washers are provided for use in the locations shown on the outline and drilling plan to facilitate making a good electrical connection between the relay case, its mounting screws and the relay panel. Ground Wires are affixed to the mounting screws as required for poorly grounded or insulating panels. Other electrical connections may be made directly to the terminals by means of screws for steel panel mounting.

For detail information on the FT case refer to I.L. 41-076 for semi-flush mounting.

ADJUSTMENT AND MAINTENANCE

The proper adjustments to insure correct operation of this relay have been made at the factory and should not be disturbed after receipt by the customer.

Acceptance Tests:

The following check is recommended to insure that the relay is in proper working order. Refer to the internal schematics and apply voltage or current to the proper terminals.

1. Minimum Trip Current – Check pickup at minimum and maximum settings. This is accomplished by applying the specified voltage or current and checking the pickup of the output telephone relay when the ac input is within $\pm 5\%$ of the settings.

2. Dropout Ratio – After checking pickup, gradually reduce the input. The dropout should be greater than 92% and 90% of the pickup for SSV-T and SSC-T relays respectively.

Repeat above except to pass 85% of ICS nameplate rating current. Contacts should not pick up and target should not drop.

ROUTINE MAINTENCE

All relays' calibration should be checked and contacts should be cleaned at least once every year. A contact burnisher S#182A836H01 is recommended for cleaning purpose. It is recommended to change the potentiometer R2 every ten years.

CALIBRATION

Use the following procedure for calibrating the relay if the relay adjustments have been disturbed. This procedure should not be used until it is apparent that the relay is not in proper working order. A new scale plate may be necessary when parts are changed.

Dial Calibration – 1. Connect on ohmmeter across proper relay terminals which connect to the telephone relay contacts.
2. Apply the desired voltage or current to relay terminals 8 and 9.
3. Turn potentiometer on front of relay counter-clockwise from extreme clockwise position until the relay operates as indicated by the ohmmeter.

Indicating Contactor Switch (ICS)

Initially adjust unit on the pedestal so that armature fingers do not touch the yoke in the reset position. This can be done by loosening the mounting screw in the molded pedestal and moving the ICS in the downward position.

1. Contact Wipe – Adjust the stationary contacts so that both stationary make with the moving contacts simultaneously and wipe 1/64" to 3/64" when the armature is against the core.

For double trip ICS units, adjust the third contact so that it makes with its stationary contact at the same time as the two main contacts or up to 1/64" ahead.

2. Target – Manually raise the moving contacts and check to see that the target drops at the same time as the contacts made or up to 1/16" ahead. The cover may be removed and the tab holding the target reformed slightly if necessary. However care should be exercised so that the target will not drop with a slight jar.

3. Pickup – Unit should pickup at 98% of rating and not pickup at 85% of rating. If necessary the cover leaf springs may be adjusted. To lower the pickup current use a tweezer or similar tool and squeeze each leaf spring approximate equal by applying the tweezer between the leaf spring and the front surface of the cover at the bottom of the lower window.

If the pickup is low the front cover must be removed and the leaf spring bent outward equally.

RENEWAL PARTS

Repair work can be done most satisfactorily at the factory. However, interchangeable parts can be furnished to customers who are equipped for doing repair work. When ordering parts, always give the complete nameplate data.

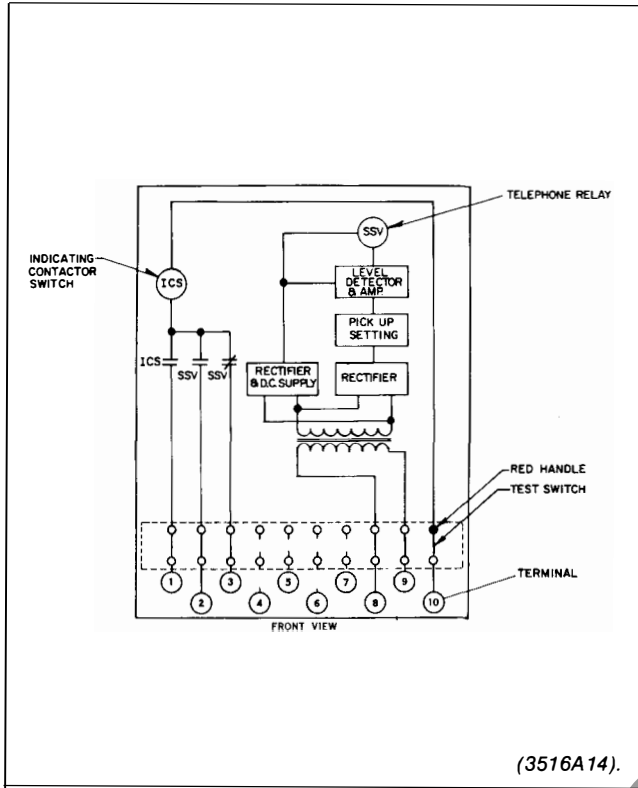

Fig. 1. Block Diagram of the Type SSV-T Relay in the Type FT-11 Case

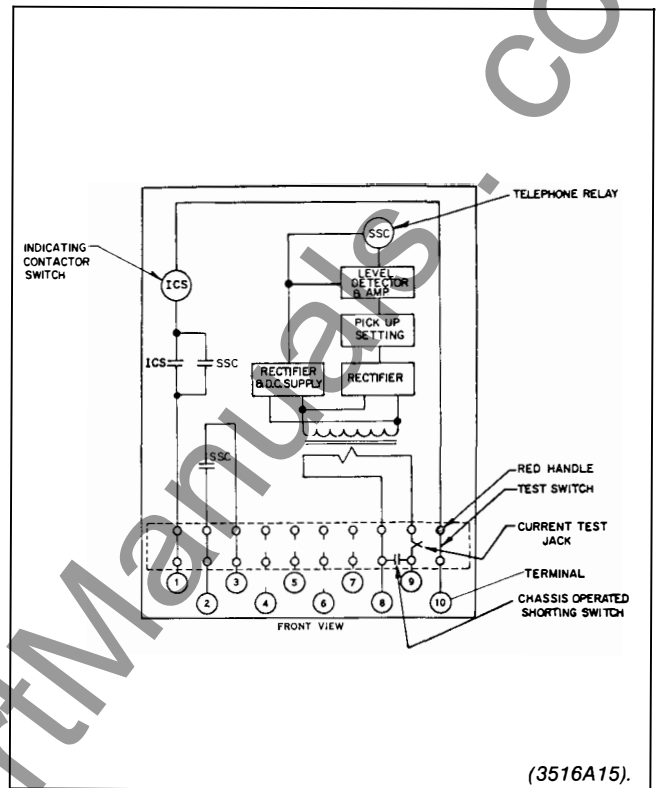

Fig. 2. Block Diagram of the Type SSC-T Relay in the Type FT-11 Case

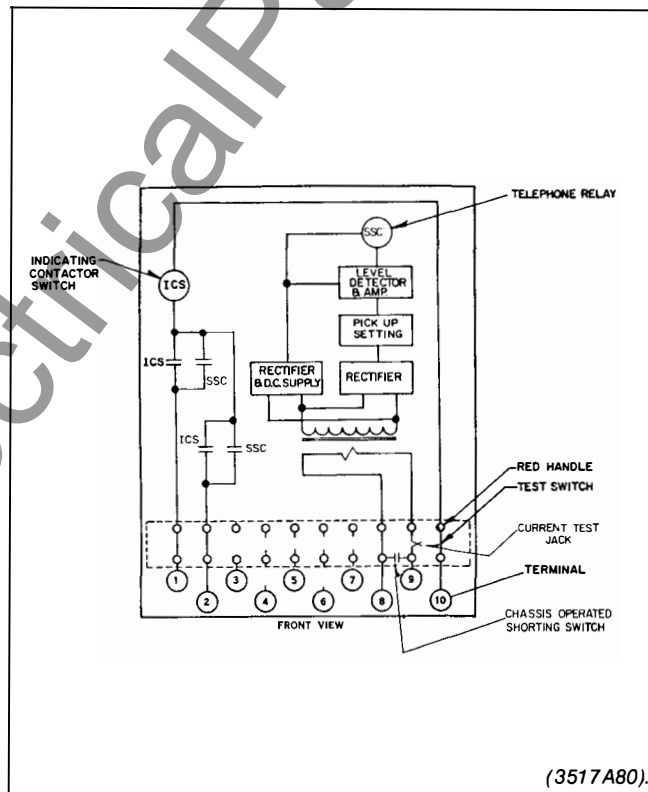

Fig. 3. Block Diagram of the Type SSC-T Relay (Double Trip)

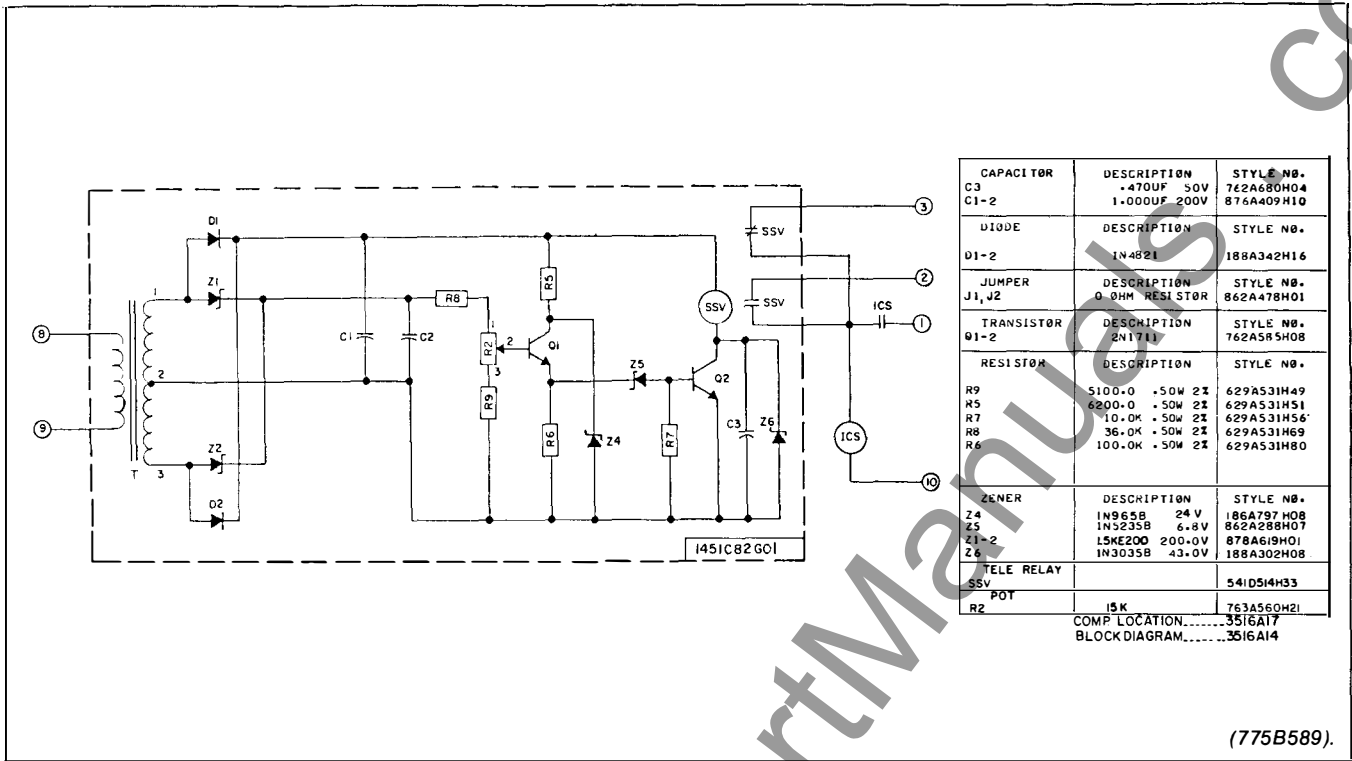

Fig. 4. Internal Schematic of the Type SSV-T Relay

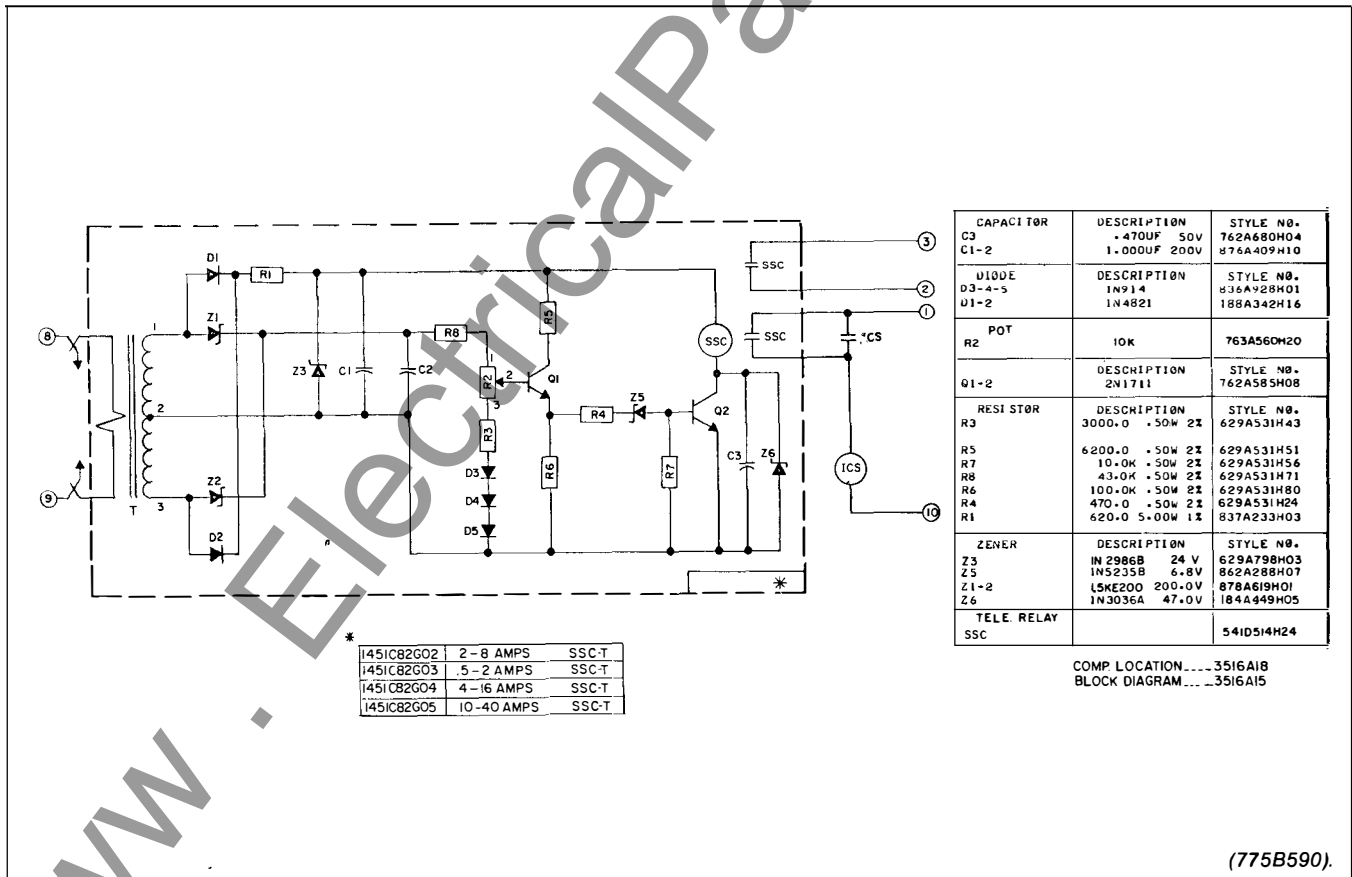

Fig. 5. Internal Schematic of the Type SSC-T Relay

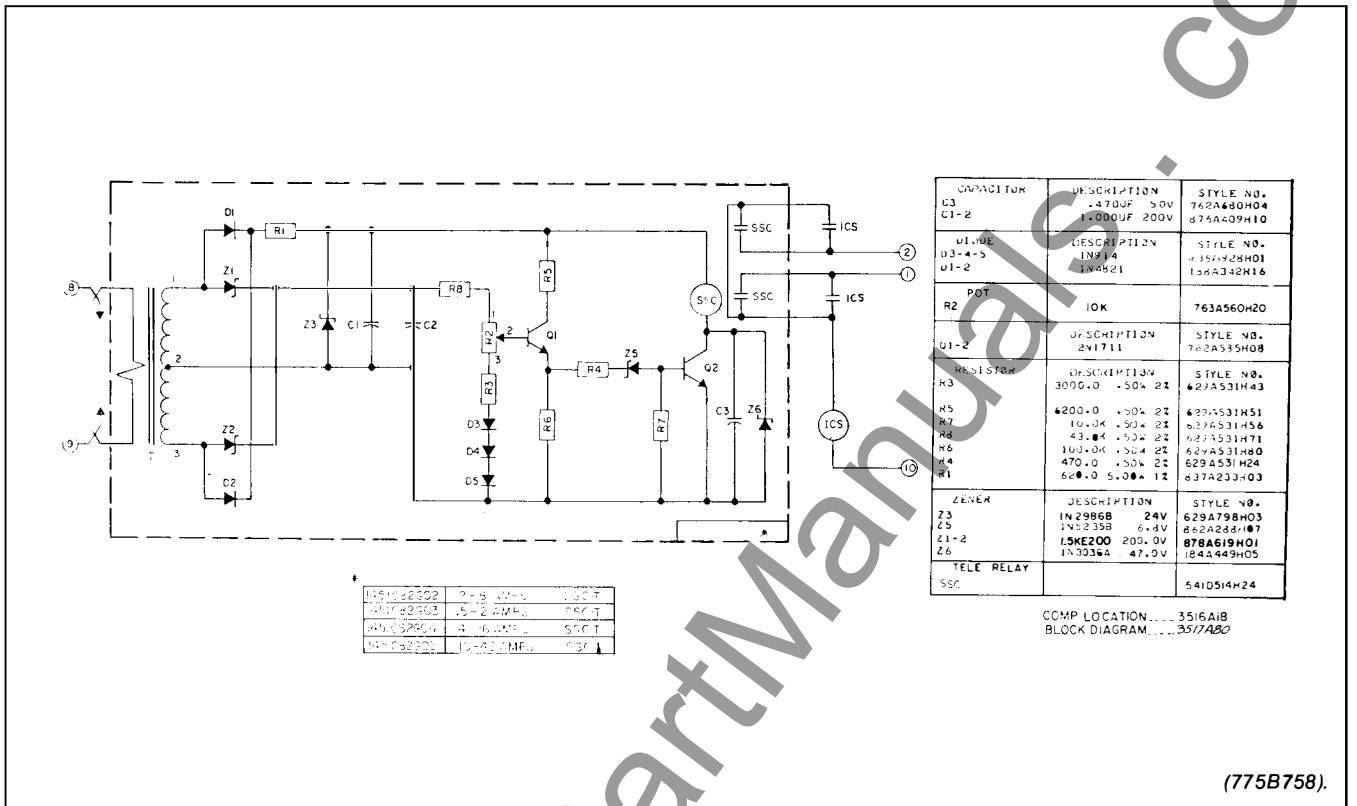

Fig. 6. Internal Schematic of the Type SSC-T Relay (Double Trip)

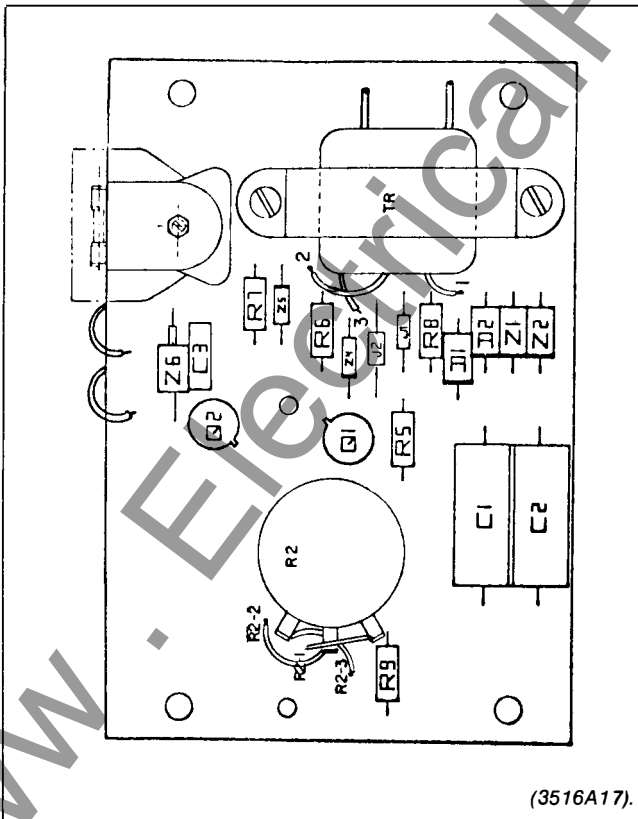

Fig. 7. Component Location on SSV-T Module

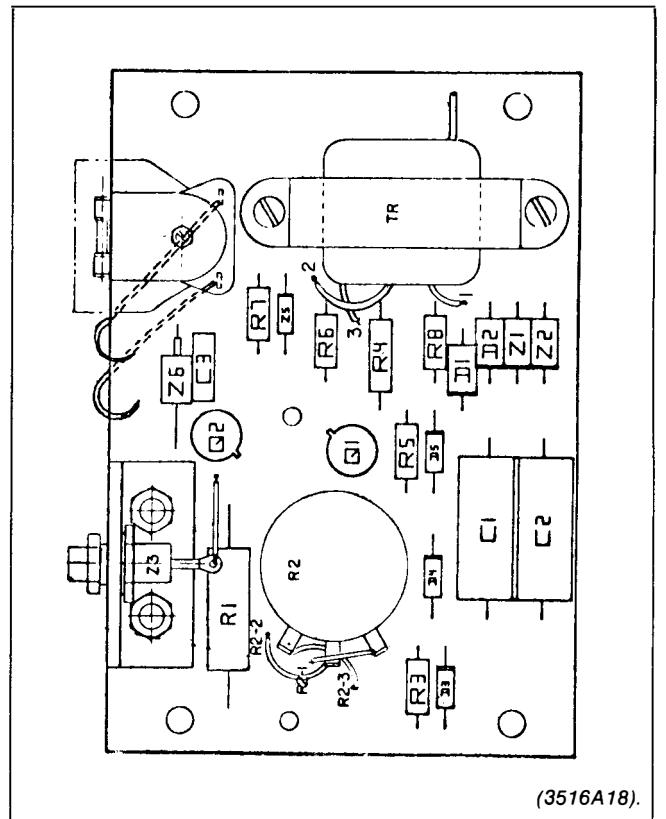
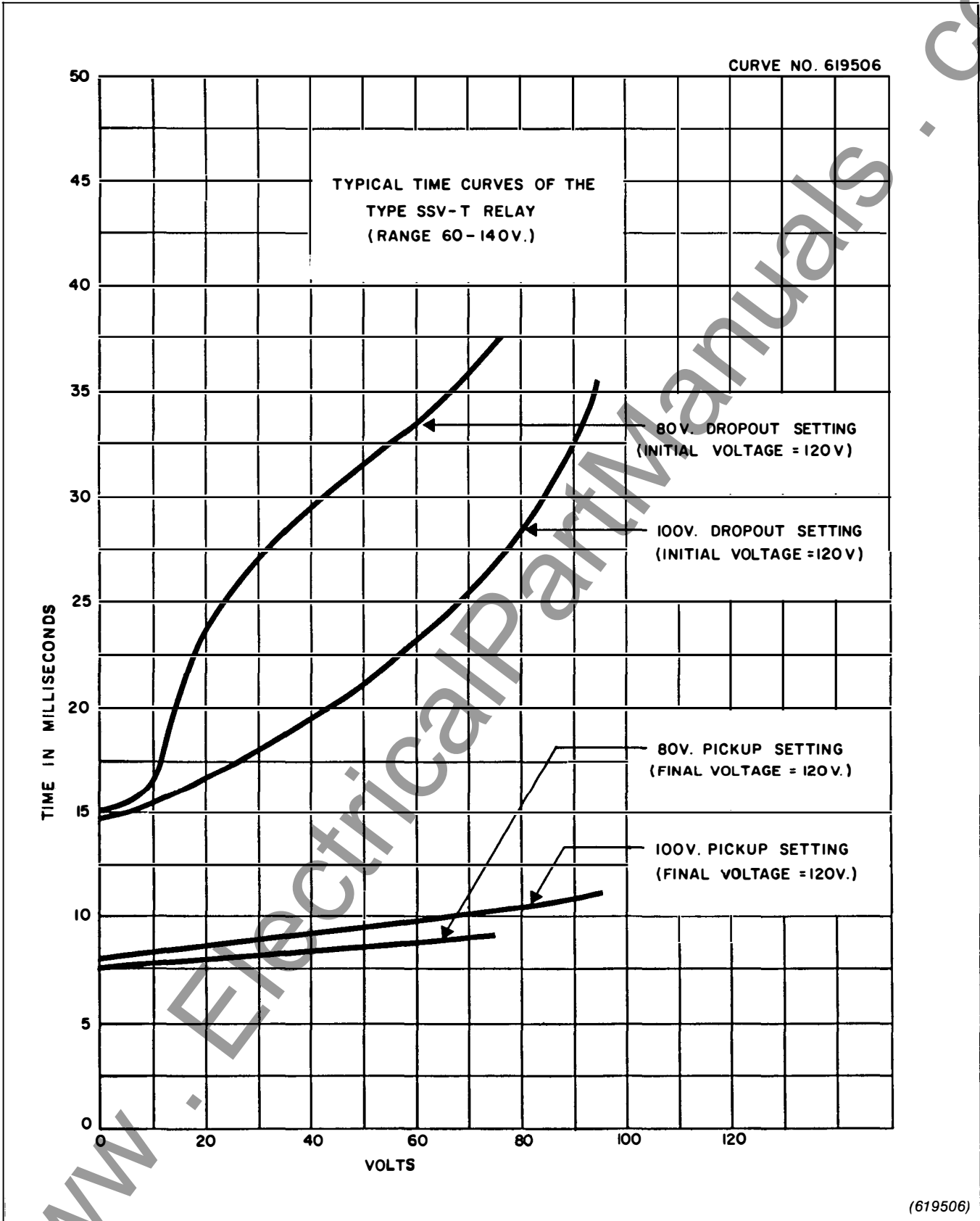

Fig. 8. Component Location on SSC-T Module



(619506)

Fig. 9. Typical Operating and Reset Time Curves of the Type SSV-T Relay

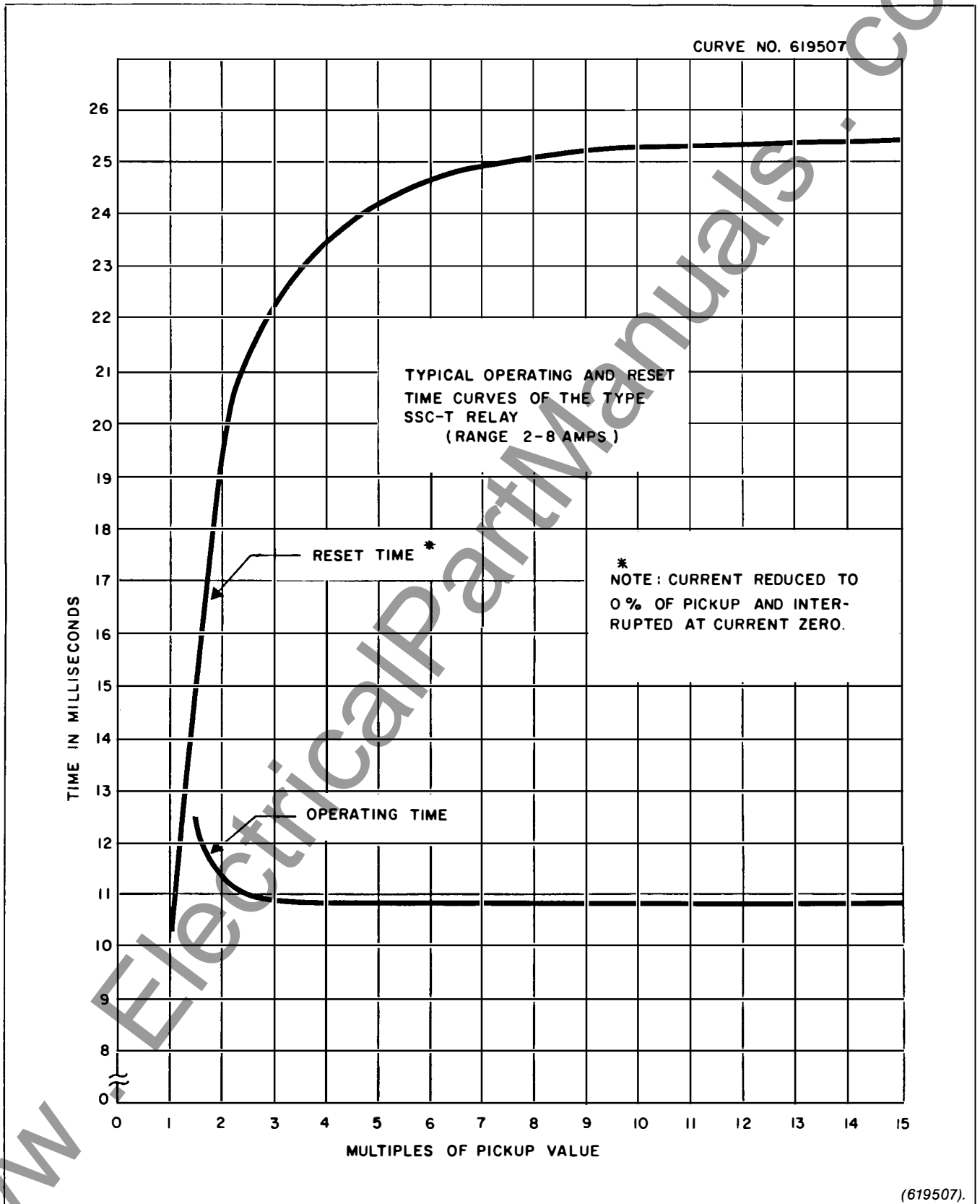
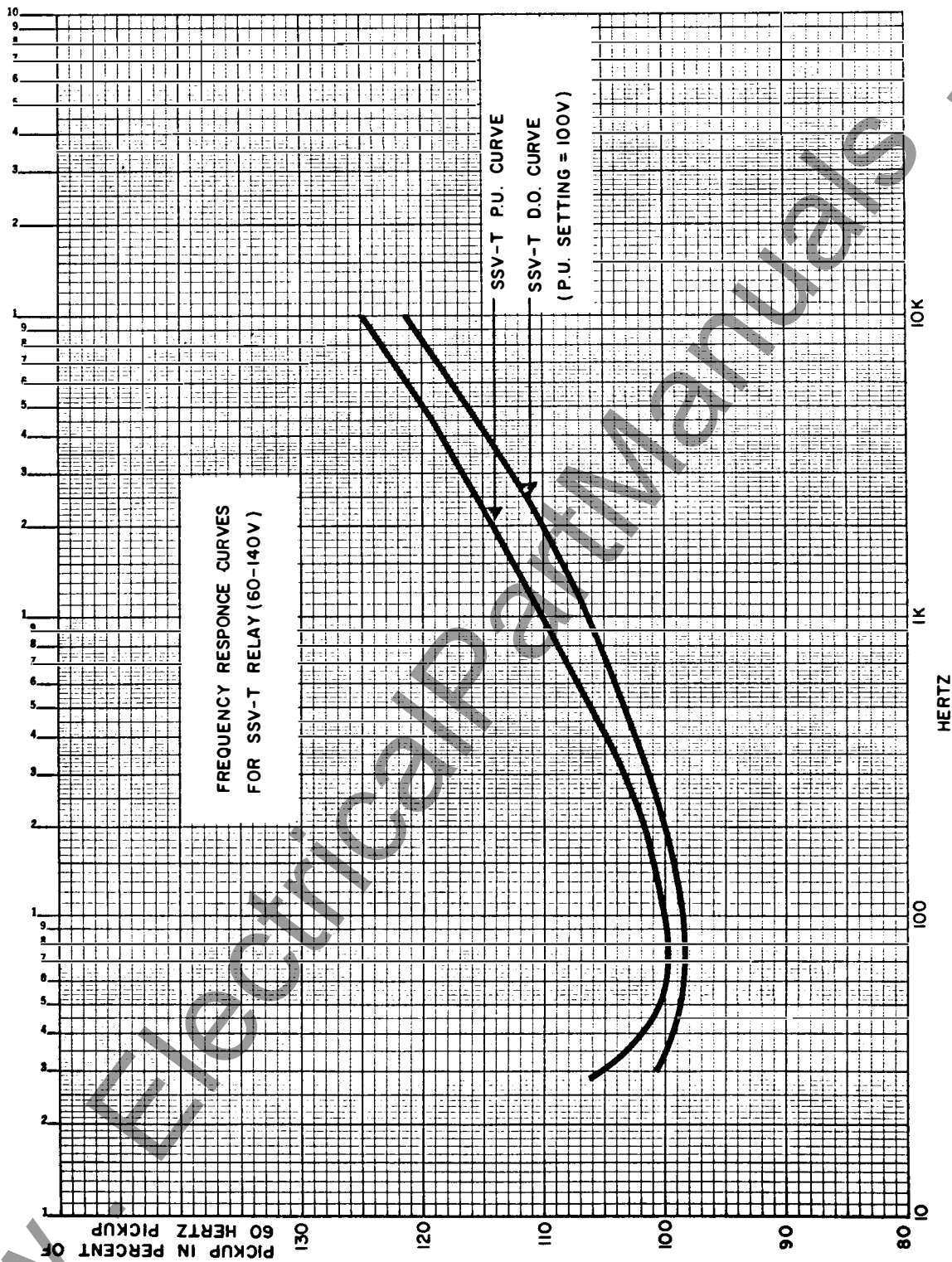

Fig. 10. Typical operating and Reset Time Curves of the Type SSC-T Relay

CURVE NO. 619504



(619504).

Fig. 11. Typical Frequency Response Curve of the Type SSV-T Relay

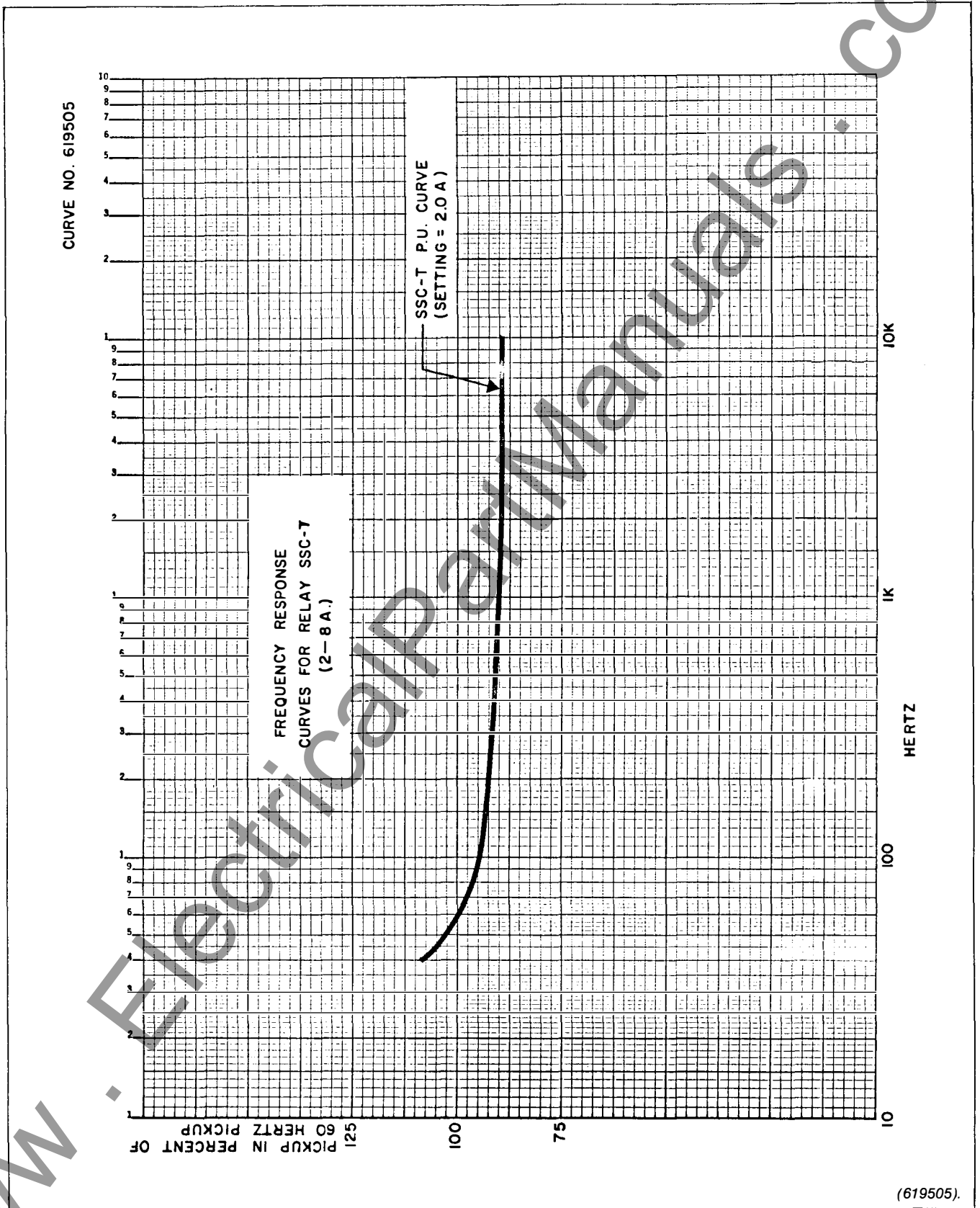
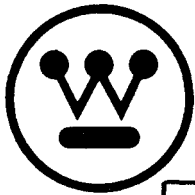

Fig. 12. Typical Frequency Curve of the Type SSC-T Relay

(619505).



INSTALLATION • OPERATION • MAINTENANCE I N S T R U C T I O N S

TYPES SC, SC-1, SV AND SV-1 RELAYS

CAUTION Before putting protective relays into service, remove all blocking which may have been inserted for the purpose of securing the parts during shipment, make sure that all moving parts operate freely, inspect the contacts to see that they are clean and close properly, and operate the relay to check the settings and electrical connections.

APPLICATION

The types SC and SC-1 current relays and the types SV and SV-1 voltage relays are applicable where an instantaneous plunger relay of high accuracy is required. These relays are suitable for protective service, and for auxiliary service where some of their special features are desired. They are adjustable over a wide range of voltage or current, are provided with mechanical operation indicators, and have a calibrated scale which indicates the pick-up setting. Both contacts can readily be changed from "make" to "break". The volt-ampere burden is low.

The type SC and SV relays have a high ratio of drop-out to pick-up (90 to 98%) and are particularly suitable for fault detector relays. The type SC-1 and SV-1 relays have a lower ratio of drop-out to pick-up. This lower ratio may be desirable in some applications, and it makes possible a plunger pull characteristic which permits the operation of a latching device. The latch is combined with the mechanical operation indicator, and prevents further motion of the moving contacts after the relay has operated.

CONSTRUCTION

The types SC, SC-1 and SV and SV-1 relays operate on the solenoid principle. A U-shaped iron frame, mounted on the moulded base, supports the coil and serves as the external magnetic path for the coil. The coil surrounds a core and flux shunt. The upper end of the core is threaded and projects through the upper side of the frame, to which it is fastened by a nut. A tube threaded on the outside at its lower end is assembled in the core, and the threaded end extends below the core. A Fluorosint® bushing, which is the lower

® The Polymer Corp.

SUPERSEDES I.L. 41-766.1F

*Denotes change from superseded issue.

bearing for the plunger shaft, is assembled in the lower end of this threaded tube. It is held in place by two split spring sleeves, one above and one below the bearing. The split sleeves must be compressed to insert them in the tube and they will remain at any position in which they are placed. The bearing for the upper end of the plunger shaft is a Fluorosint® bushing which is pressed in the upper end of the core. This bearing is visible when the plunger is in the energized position. The plunger itself does not touch the walls of the tube in which it moves.

A flux shunt which surrounds the core is screwed on the tube, and its lower end projects below the relay frame. The position of this shunt determines the pick-up setting of the relay. The lower end of the shunt is beveled and knurled, so that it can be grasped by the fingers and turned to change the setting. A calibrated scale plate is mounted adjacent to the shunt. A groove just above the knurl in the lower end of the shunt serves as an index mark, and the relay pick-up setting is indicated by the calibration scale marking which is adjacent to the groove.

The construction of the plunger, core and flux shunt (which differ in details in the various types of these relays) causes the plunger to float in its energized position, without being held against a stop, even when energized much above the pick-up value. Consequently, there is negligible noise and the contacts are free from chatter, even on heavy overloads and in 25 cycle applications.

The core, shunt and plunger construction also provides the high ratio of drop-out to pickup in the SC and SV relays. This ratio is above 90% for any pick-up setting. In the latch type relays it is necessary for the plunger to rise with sufficient force to operate the latch positively and to deflect the stationary contacts sufficiently to prevent their opening, when the relay is de-energized, due to play in the latch. It is necessary to have a lower ratio of drop-out to pick-up in, order to obtain this characteristic, and this lower ratio may be desirable in some applications where the latch is not required. The plunger

EFFECTIVE FEBRUARY 1973

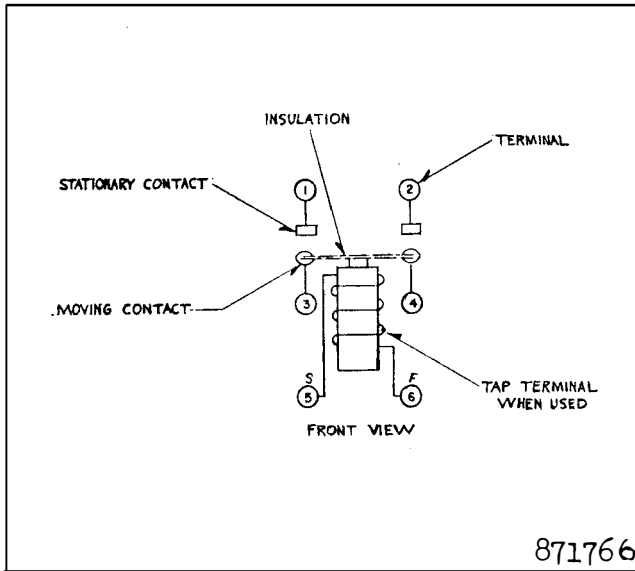

871766

Fig. 1. Internal Wiring of the Relays In The Small Glass Case.

floats in its operated position just as in the SC and SV relays. The drop-out ratio varies somewhat for different shunt positions, but is constant for any one setting.

The shunt is held in any desired position by pressure from a curved arm made of sheet spring steel, which is fastened to the bottom of the coil frame at the rear of the shunt. This spring arm is shaped to extend around the shunt to the front of the relay, and in its normal position it exerts sufficient pressure against the shunt to prevent any creeping of the shunt or undesired change of setting. The front end of the spring arm has a bent-over tab on which thumb-pressure may be applied to move the arm out of contact with the shunt while the position of the latter is being changed.

The stationary contacts are assembled on slotted brackets. These are held in position on the base by filister-head screws which are threaded into the terminal inserts. Lock-washers are assembled inside the moulded terminal bushings between the inserts and the base, as a safeguard against loosening of the screws. By rotating the bracket on its mounting screw and moving it along its slot, the contact assembly can be made either normally open or normally closed. The moving contacts are mounted on a Micarta insulation plate which is secured to the threaded end of the plunger shaft by a nut. The front edge of this insulation plate operates the indicator. The rear portion of the plate is slotted and a post screwed to the frame passes through this slot to prevent the plate from rotating.

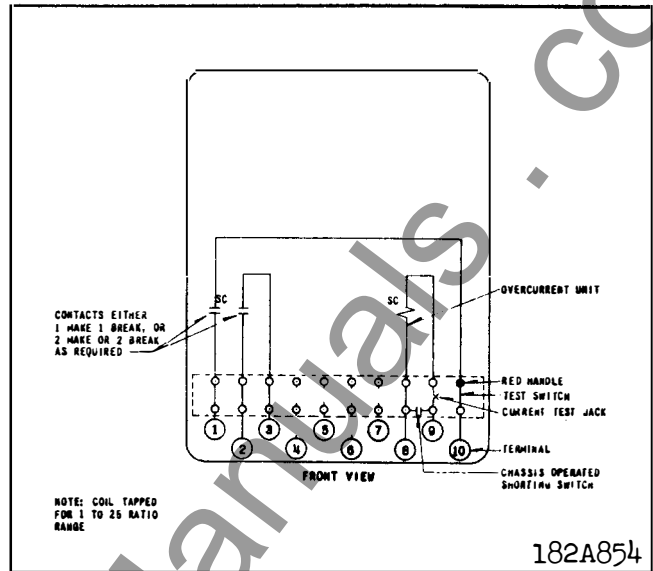

182A854

Fig. 2. Internal Schematic of the Single Unit Type SC or SC-1 Relay in The Type FT21 Case.

The moving contacts are double-faced so that they can be 'make' or 'break' and are connected to the base terminals by flexible leads. All contacts are pure silver. The contacts will carry 5 amperes continuously, and will interrupt 5 amperes at 115 volts A-C, or 1 ampere at 125 volts D-C.

The mechanical operation indicators used on these relays are shockproof, and can be used to indicate on the up stroke or down stroke of the plunger. The indicator is reset by pulling out the knurled stud which projects through the cover nut. The indicator should be reset after each relay operation because otherwise there may be a one or two percent decrease in the operating value of the relay. The operation indicator is assembled at the factory to indicate on the up stroke of the plunger, but by removing the two mounting screws which fasten the indicator to the main frame, turning the indicator bracket around and at the same time swinging the indicator flag 180° about its shaft, the indicator can be set to indicate on the down stroke of the plunger. The rivet weight must be removed from the indicator flag and the latch screen turned around to complete the assembly.

In certain applications, an extremely wide range of current adjustment is desirable, and certain styles of SC and SC-1 relays have been provided with tapped coils to meet this requirement. The coil taps are brought out to a tap block mounted on the lower end of the relay frame or on the relay sub-base, depending on the type of case used. The connector plate on the tap block is marked with the minimum pick-up value of

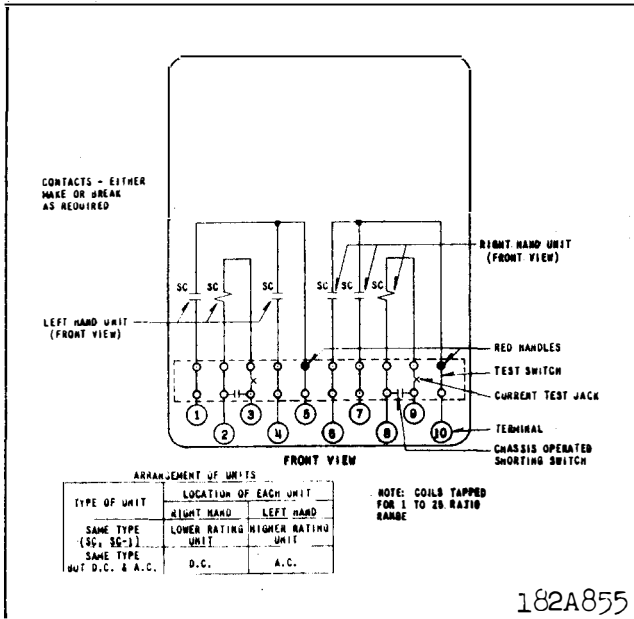

Fig. 3. Internal Schematic of the Double Unit Type SC or SC-1 Relay in the Type FT21 Case.

each tap, and the shunt is adjusted in the usual manner to obtain any pick-up setting between taps. The scale plate is not calibrated for the relays with tapped coils, as there is not sufficient space for marking a scale for each tap. However, the scale plate is supplied in order that a customer may mark on it the individual relay setting or settings if desired.

INSTALLATION

The relays should be mounted on switchboard panels or their equivalent in a location free from dirt, moisture, excessive vibration, and heat. Mount the relay vertically by means of the four mounting holes on the flange for semi-flush mounting or by means of the rear mounting stud or studs for projection mounting. Either a mounting stud or the mounting screws may be utilized for grounding the relay. The electrical connections may be made directly to the terminals by means of screws for steel panel mounting or to the terminal studs furnished with the relay for thick panel mounting. The terminal studs may be easily removed or inserted by locking two nuts on the stud and then turning the proper nut with a wrench.

For detailed FT case information refer to I.L. 41-076.

ADJUSTMENTS AND MAINTENANCE

The proper adjustments to insure correct operation of this relay have been made at the factory and

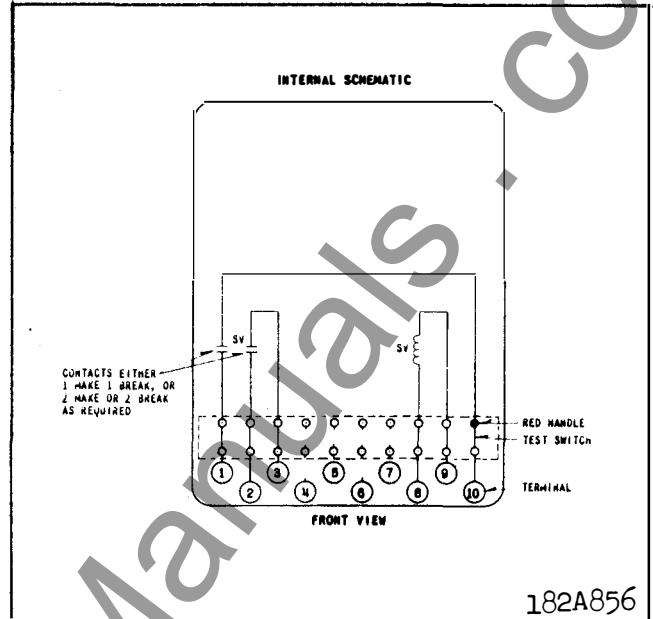

Fig. 4. Internal Schematic of the Single Unit Type SV or SV-1 Relay in the Type FT21 Case.

should not be disturbed after receipt by the customer. If the adjustments have been changed, the relay taken apart for repairs, or if it is desired to check the adjustments at regular maintenance periods, the instructions below should be followed.

All contacts should be cleaned periodically. A contact burnisher S#182A836H01 is recommended for this purpose. The use of abrasive material for cleaning contacts is not recommended, because of the danger of embedding small particles in the face of the soft silver and thus impairing the contact.

Several factors may affect the drop-out ratio of the relay. Whatever affects the ratio does so because either the drop-out or pick-up or both are affected. Obviously, incorrect assembly or interchange of parts, such as the use of the SC plunger with the SV core tube, will alter the electrical characteristics. However, the factor most likely to be encountered in service is friction. This may be due to dirt or foreign material between the plunger shaft and its bearings, to excessive pressure of the indicator screen on the indicator, or to leads so mis-shaped that they tend to rotate or tilt the moving contact insulation plate with appreciable force.

In order to remove the plunger and shaft assembly, it is necessary to remove the setscrew and nut at the top of the shaft. The spool-shaped bushing assembled on the upper end of the plunger shaft has a portion of

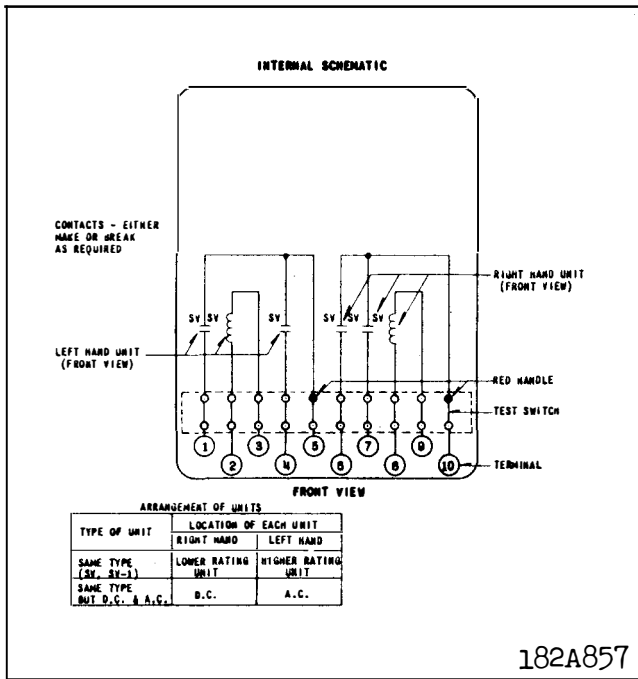

Fig. 5. Internal Schematic of the Double Unit Type SV or SV-1 Relay in the Type FT32 Case.

its center section machined off so that the shaft is exposed at this point and can be prevented from turning by gripping shaft and bushing with a pair of long-nose pliers while removing the set screw and nut. Then by pressing down with the fingers on the upper end of the shaft, the lower split sleeve which retains the lower bearing will be forced out of the threaded tube, the bearing will drop out freely, and the upper split sleeve will be forced out far enough to permit grasping it for removal. The shaft and plunger assembly then can be removed.

The shaft and plunger assembly should be handled carefully to avoid bending the shaft or damaging the bearing surfaces. The shaft should never be gripped on its upper bearing surface, below the spool-shaped bushing, when loosening the nut and setscrew, as this would almost certainly damage the bearing surface. The shaft bearing surfaces should not be cleaned or polished with any abrasive material, as the abrasive particles might become imbedded in the shaft and cause difficulty later. The plunger shaft and bearings may be cleaned by wiping them carefully with a clean, lint-less cloth. This may be moistened with benzene or some other cleaning solvent if necessary. Use no lubricant on the plunger shaft or bearings when re-assembling the relay, since this will eventually become gummy and prevent proper operation. It is recommended that the shaft be clean-

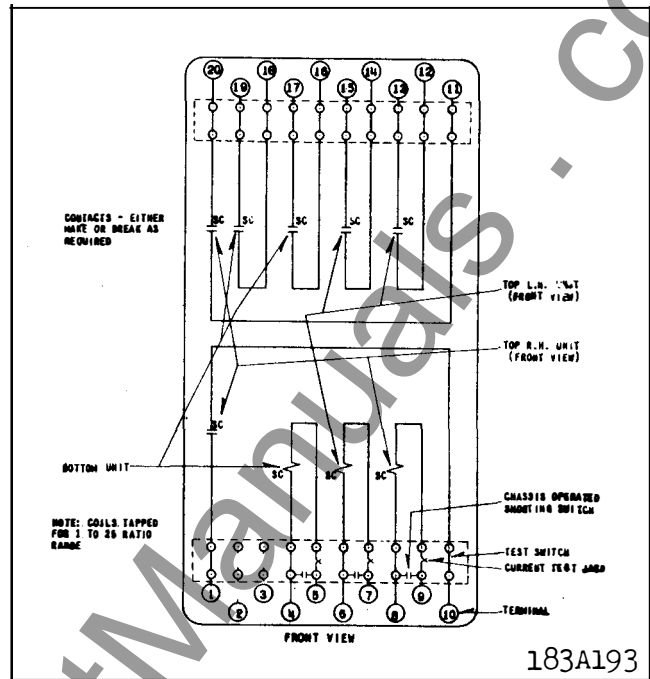

Fig. 6. Internal Schematic of the Three Unit Type SC or SC-1 Relay in the Type FT32 Case.

ed at intervals of approximately two years. When replacing the lower bearing and the split sleeves, the shorter sleeve (assembled below the bearing) should be pushed in until it is flush with the end of the threaded tube.

The mounting holes in the operation indicator screen are slotted so that its position can be adjusted. For relays in which the moving contacts are not latched in the operated position, the screen should be so located that the indicator positively enters the screen opening when the contacts barely touch. For latch-type relays, the screen should be so located that good contact is still obtained when the relay is de-energized. The pressure of the screen against the indicator may be adjusted by bending the screen between its lower end and the large elongated hole. This pressure should be such that the indicator will be held at any further position to which it is moved after entering the screen opening. However, the minimum amount of pressure necessary to obtain this adjustment should not be exceeded appreciably, since the pick-up value, and consequently the ratio, will be affected. The purpose of this pressure is to eliminate indicator rattle which might otherwise occur under certain energized conditions.

The moving contact leads pass through insulation sleeves assembled on the shanks of the terminal clips

CHARACTERISTICS OF TYPES SC AND SC-1 RELAYS

Type	Frequency	Range of Adjustment Amps.	Max. Amps. Continuous	Watts 5 Amps. 60 Cycles	V.A. at 5 Amps. 60 Cycles	Dropout Ratio-AC	Dropout Ratio-DC
SC	DC, 25 to 60 hz.	.5-2	1.5	99	225	90-98%	65-80%
SC	DC, 25 to 60 hz.	1-4	3	28	65	90-98%	65-80%
SC	DC, 25 to 60 hz.	2-8	6	6.9	19	90-98%	65-80%
SC	DC, 25 to 60 hz.	4-16	12	1.5	5	90-98%	65-80%
SC	DC, 25 to 60 hz.	10-40	25	.24	.7	90-98%	65-80%
SC	DC, 25 to 60 hz.	20-80	40	.07	.16	90-98%	65-80%
SC	DC, 25 to 60 hz.	40-160	40	.03	.05	90-98%	65-80%
SC	DC, 25 to 60 hz.	4-100*	10-15-20	1.7-0.6-0.18	5-1-0.2	90-98%	65-80%
SC-1	DC, 25 to 60 hz.	.5-2	1.5	100	210	35-60%	25-40%
SC-1	DC, 25 to 60 hz.	1-4	3	24	60	35-60%	25-40%
SC-1	DC, 25 to 60 hz.	2-8	6	6	16	35-60%	25-40%
SC-1	DC, 25 to 60 hz.	4-16	12	1.5	5	35-60%	25-40%
SC-1	DC, 25 to 60 hz.	10-40	25	.25	.65	35-60%	25-40%
SC-1	DC, 25 to 60 hz.	20-80	40	.07	.16	35-60%	25-40%
SC-1	DC, 25 to 60 hz.	40-160	40	.03	.05	35-60%	25-40%
SC-1	DC, 25 to 60 hz.	4-100*	10-15-20	1.7-0.6-0.18	5-1-0.2	35-60%	25-40%

* Coil has taps on which minimum pickups are 10 and 30 amperes.

CHARACTERISTICS OF SV AND SV-1 RELAYS

Type	Frequency (Cycles)	Range of Adjustment Volts	Max. Volts Continuous	Watts at 115 V. AC (125 V. for DC)	V.A. at 115 V.	Dropout Ratio
SV	60	7-16	16	-	-	90-98%
SV	60	70-160	160	3.4	7.3	90-98%
SV	60	140-320	320	-	-	90-98%
SV	60	280-640	640	-	-	90-98%
SV	50	70-160	180	2.8	6.1	90-98%
SV	25	70-160	200	1.5	2.5	90-98%
SV	DC	50-150	150	4.8	-	65-80%
SV	DC	100-300	300	-	-	65-80%
SV-1	60	7-16	16	-	-	40-80%
SV-1	60	70-160	160	4.1	8.5	40-80%
SV-1	60	140-320	320	-	-	40-80%
SV-1	60	280-640	640	-	-	40-80%
SV-1	50	70-160	180	3.5	7.1	40-80%
SV-1	25	70-160	200	1.4	3.2	40-80%
SV-1	DC	50-150	150	4.8	-	25-40%
SV-1	DC	100-300	300	-	-	25-40%

NOTES:--Standard current relays are calibrated on 60 cycles. This calibration is approximately correct for 25 cycle and DC applications, but there will be discrepancies of 10% to 15% at some points of scale.

Values of watts and volt-amperes in the tables are average for various plunger and shunt position.

For the SC relay, volt-amperes for pickup at minimum setting are approximately 3.4 and 1.4 for 60 and 25 cycles. Watts at minimum setting are approximately 1.0, .65 and .57 for 60 cycles, 25 cycles and DC respectively. Multiply values by 16 for approximate burdens at maximum setting.

For the SC-1 relay, volt-amperes for pickup at minimum setting are approximately 3.5 and 1.3 for 60 and 25 cycles. Watts at minimum settings are 1.3, .7 and .57 for 60 cycles, 25 cycles and d-c respectively. Multiply values by 16 for approximate burdens at maximum setting.

*The V.A. burdens of the SC and SC-1 relays at 3, 10 and 20 times minimum pickup current are approximately 31, 240 and 770 V.A. respectively.

Dropout ratio varies somewhat with pickup adjustment but will be approximately constant for any given pickup setting. Limits in tables include variables such as friction and other individual relay variations.

Maximum continuous volts given for the SV and SV-1 relays for A-C are for the relay set for minimum pickup. With the relay set for maximum pickup the continuous voltage can be increased 10 to 20%.

TYPES SC, SC-1, SV AND SV-1 RELAYS

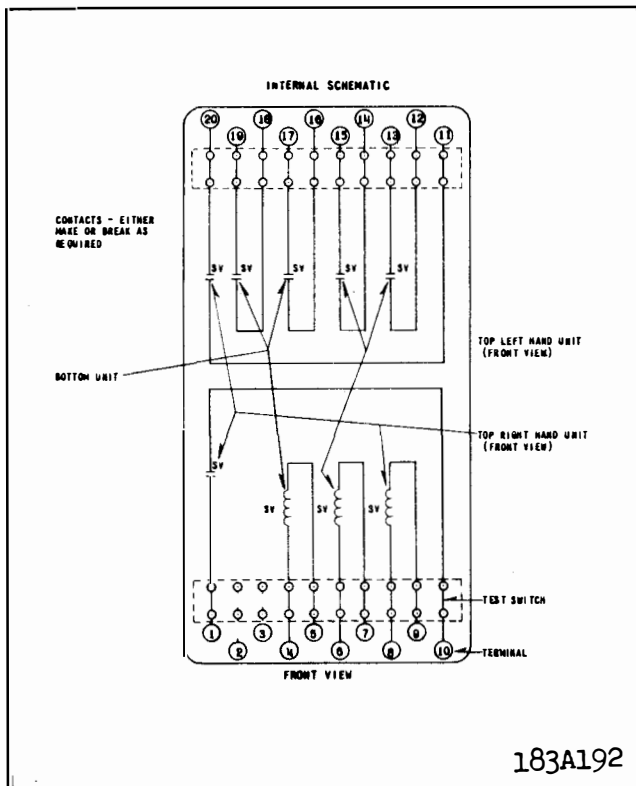

Fig. 7. Internal Schematic of the Three Unit Type SV or SV-1 Relay in the Type FT32 Case.

which are attached to the base terminals. These sleeves are notched at their upper ends, and the notches are toward the center of the relay. The leads are bent at approximately a right angle where they pass out through the notches, which aids in preventing them from coming into contact with the stationary contact brackets. Figure 11 shows properly coiled and assembled moving contact leads.

Although the moving contact leads are very flexible, if the leads have been pulled out of their original shape by handling they may exert sufficient side pressure on the shaft bearing or twisting force against the guide post to cause appreciable friction and wear. If this condition continues for a long period of time, the resulting wear may affect the relay calibration or or the dropout ratio noticeably. In extreme cases the wear may progress to a degree which may occasionally cause failure of the plunger to drop down when the relay is de-energized.

Correct shaping of the leads is not difficult, and they may be checked readily by removing the guide post and the nut at the top of the shaft. The plunger should be held in the raised position, either by energizing the relay or by pressing lightly against the

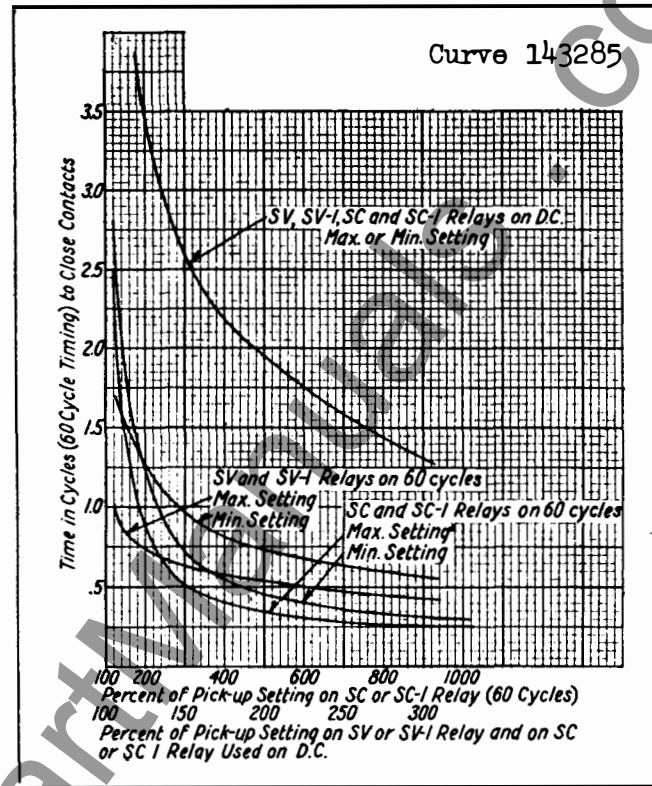

Fig. 8. Typical Time Curves for the Types SC and SV Relays (Using Flux Shunt for Pick-up Adjustment.)

collar under the insulation plate after raising the plunger manually. With the plunger raised, the insulation plate should be oscillated slightly in a horizontal plane by twisting it horizontally and releasing it. If in several trials the plate comes to rest with the center line of the contacts approximately parallel to the base and with its mounting hole fairly well centered with the end of the shaft, if the plate does not tip appreciably, and if the leads have a safe clearance to the stationary contact brackets, the leads are properly shaped.

If this check shows that re-shaping is necessary, it may be possible to obtain sufficient correction by bending the leads sharply where they emerge from the insulation sleeves. One or two pairs of tweezers are tools for re-shaping the leads. If it is necessary to re-coil the leads, they should be wound around a rod having a diameter of approximately $5/32$ ". The coils then should be stretched out just enough to avoid side pull or twisting force on the plunger assembly.

In all relays except the SV-1 relay for A-C, if the stationary contacts are assembled so that they close when the relay is energized, they should be located so that they barely touch the moving contacts when

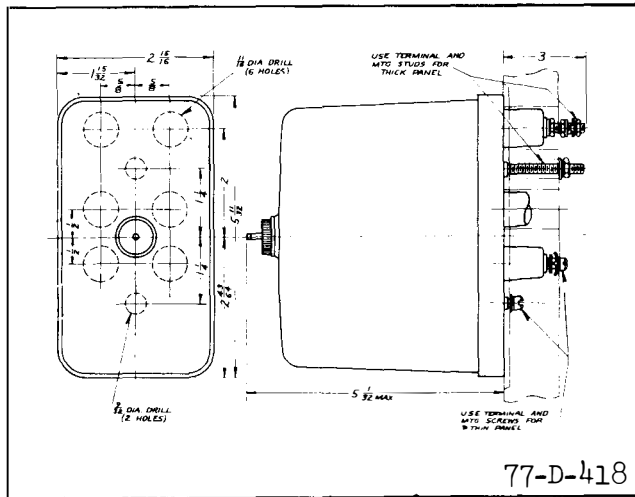

Fig. 9. Outline & Drilling Plan for Single Unit Relays in Small Glass Projection Case.

the latter are $5/32''$ above the de-energized position. The moving contacts can be held in this position while the adjustment is being made by inserting a $5/32''$ spacer between the shaft collar and the top of the core. This dimension should be $3/16''$ on the SV-1 relay for A-C. Both contacts should touch at the same time when the plunger is raised. When the plunger is moved upward against its stop, there should be a slight deflection of the stationary contact stop springs, but this should not exceed $1/32''$. When the stationary contacts are reversed so that they are closed when the relay is de-energized, they should be located so that they just touch the moving contacts when the latter are $1/32''$ above the de-energized position. On some relays it may be found that when the contacts are used in this position the relay may operate at values a few percent below the scale markings. The adjustments specified for the stationary contacts are important. Failure to observe them may cause improper relay operation, either directly or after a period of service. Contact position should not be used as a



Fig. 10. View of Type SC Relay Showing Correct Shaping of Moving Contact Leads.

means of altering the ratio of dropout to pickup.

RENEWAL PARTS

Repair work can be done most satisfactorily at the factory. However, interchangeable parts can be furnished to the customers who are equipped for doing repair work. When ordering parts, always give the complete nameplate data.

TYPES SC, SC-1, SV AND SV-1 RELAYS

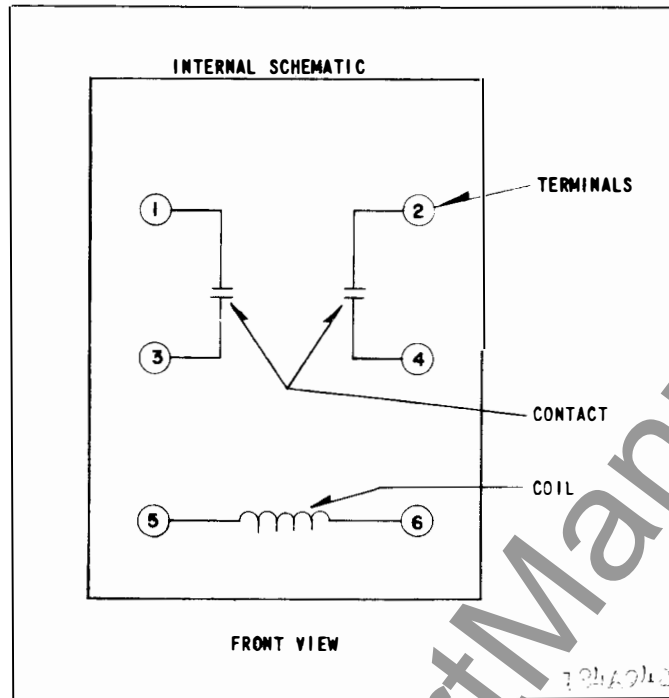

Fig. 11. Internal Schematic for Relays in Front Connected Case.

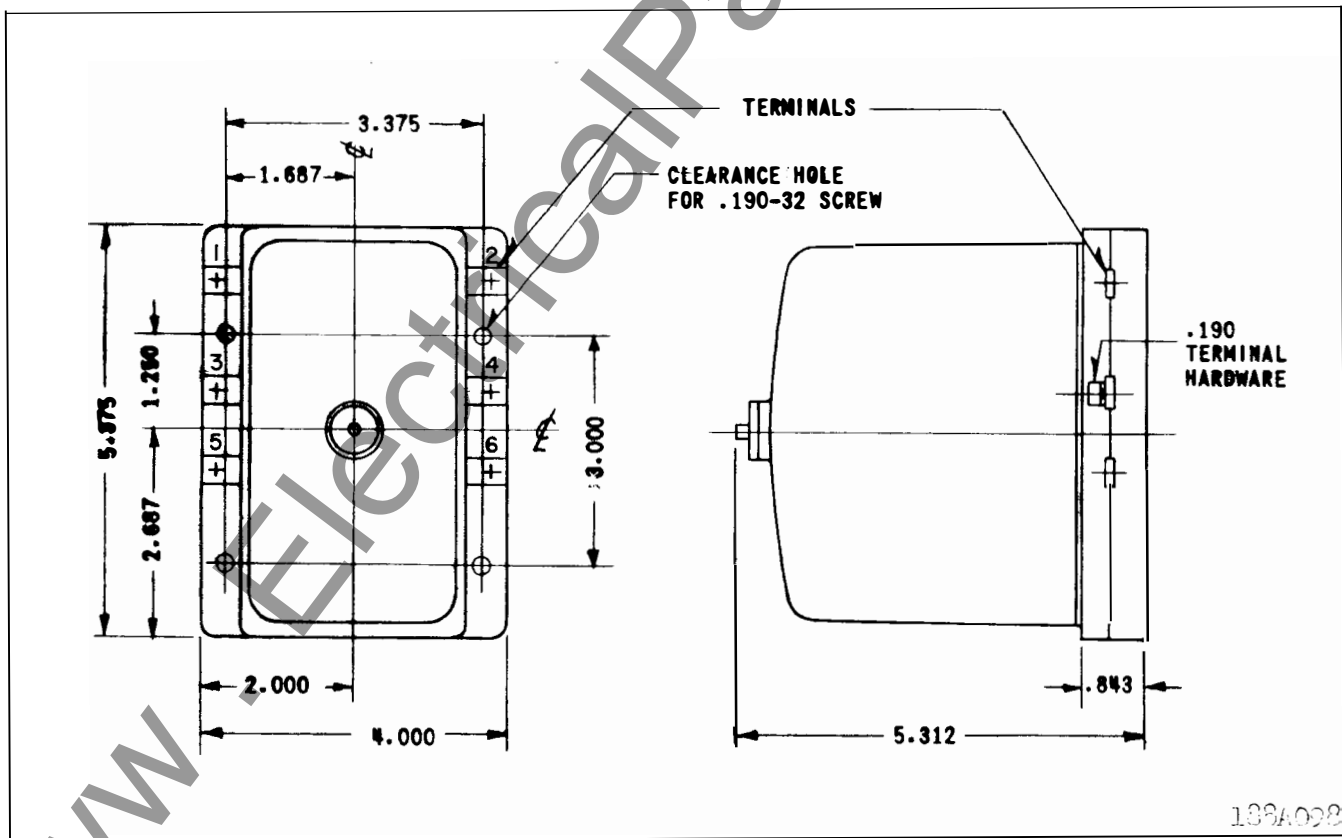

Fig. 12. Outline and Drilling Plan for Relays in Front Connected Case.

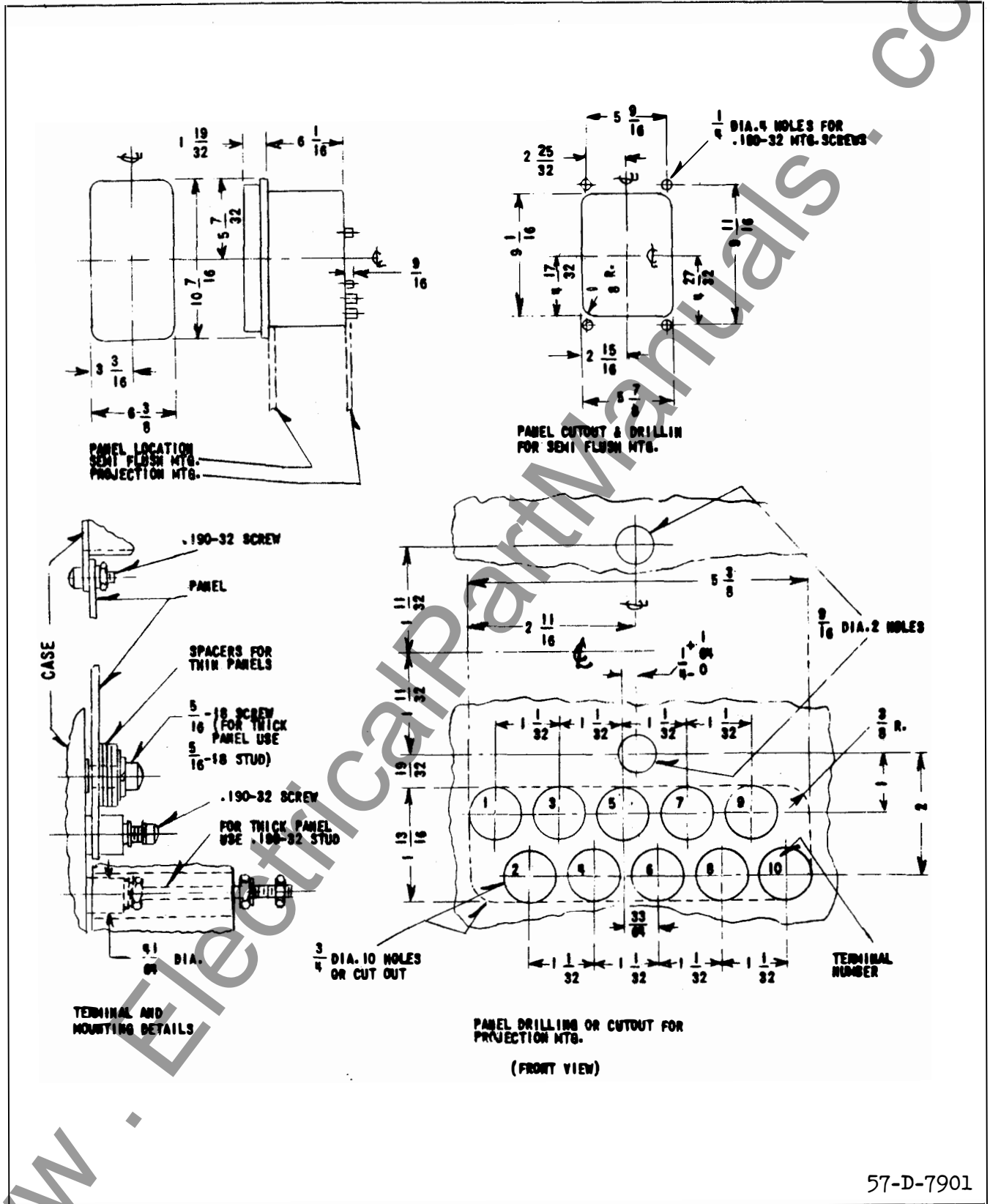
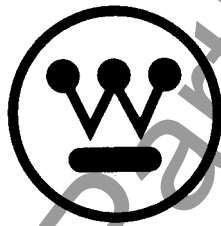

Fig. 13 Outline and Drilling Plan for Single and Double Unit Relays in the Type FT21 Case.

www.ElectricalPartManuals.com



WESTINGHOUSE ELECTRIC CORPORATION
RELAY-INSTRUMENT DIVISION

NEWARK, N. J.

Printed in U.S.A.



INSTALLATION • OPERATION • MAINTENANCE INSTRUCTIONS

TYPES SC, SC-1, SV AND SV-1 RELAYS

CAUTION Before putting protective relays into service, remove all blocking which may have been inserted for the purpose of securing the parts during shipment, make sure that all moving parts operate freely, inspect the contacts to see that they are clean and close properly, and operate the relay to check the settings and electrical connections.

APPLICATION

The types SC and SC-1 current relays and the types SV and SV-1 voltage relays are applicable where an instantaneous plunger relay of high accuracy is required. These relays are suitable for protective service, and for auxiliary service where some of their special features are desired. They are adjustable over a wide range of voltage or current, are provided with mechanical operation indicators, and have a calibrated scale which indicates the pick-up setting. Both contacts can readily be changed from "make" to "break". The volt-ampere burden is low.

The type SC and SV relays have a high ratio of drop-out to pick-up (90 to 98%) and are particularly suitable for fault detector relays. The type SC-1 and SV-1 relays have a lower ratio of drop-out to pick-up. This lower ratio may be desirable in some applications, and it makes possible a plunger pull characteristic which permits the operation of a latching device. The latch is combined with the mechanical operation indicator, and prevents further motion of the moving contacts after the relay has operated.

CONSTRUCTION

The types SC, SC-1 and SV and SV-1 relays operate on the solenoid principle. A U-shaped iron frame, mounted on the moulded base, supports the coil and serves as the external magnetic path for the coil. The coil surrounds a core and flux shunt. The upper end of the core is threaded and projects through the upper side of the frame, to which it is fastened by a nut. A tube threaded on the outside at its lower end is assembled in the core, and the threaded end extends below the core. A Fluorosint® bushing, which is the lower

bearing for the plunger shaft, is assembled in the lower end of this threaded tube. It is held in place by two split spring sleeves, one above and one below the bearing. The split sleeves must be compressed to insert them in the tube and they will remain at any position in which they are placed. The bearing for the upper end of the plunger shaft is a Fluorosint® bushing which is pressed in the upper end of the core. This bearing is visible when the plunger is in the energized position. The plunger itself does not touch the walls of the tube in which it moves.

A flux shunt which surrounds the core is screwed on the tube, and its lower end projects below the relay frame. The position of this shunt determines the pick-up setting of the relay. The lower end of the shunt is beveled and knurled, so that it can be grasped by the fingers and turned to change the setting. A calibrated scale plate is mounted adjacent to the shunt. A groove just above the knurl in the lower end of the shunt serves as an index mark, and the relay pick-up setting is indicated by the calibration scale marking which is adjacent to the groove.

The construction of the plunger, core and flux shunt (which differ in details in the various types of these relays) causes the plunger to float in its energized position, without being held against a stop, even when energized much above the pick-up value. Consequently, there is negligible noise and the contacts are free from chatter, even on heavy overloads and in 25 cycle applications.

The core, shunt and plunger construction also provides the high ratio of drop-out to pickup in the SC and SV relays. This ratio is above 90% for any pick-up setting. In the latch type relays it is necessary for the plunger to rise with sufficient force to operate the latch positively and to deflect the stationary contacts sufficiently to prevent their opening, when the relay is de-energized, due to play in the latch. It is necessary to have a lower ratio of drop-out to pick-up in, order to obtain this characteristic, and this lower ratio may be desirable in some applications where the latch is not required. The plunger

® The Polymer Corp.
SUPERSEDES I.L. 41-766.1F

*Denotes change from superseded issue.

EFFECTIVE FEBRUARY 1973

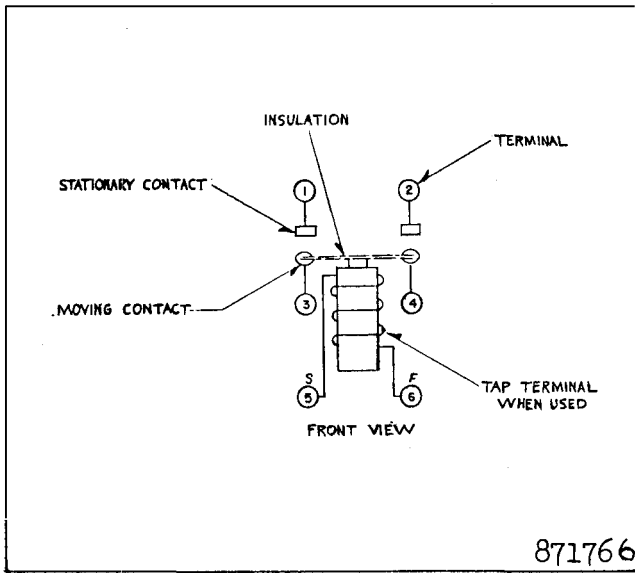

Fig. 1. Internal Wiring of the Relays In The Small Glass Case.

floats in its operated position just as in the SC and SV relays. The drop-out ratio varies somewhat for different shunt positions, but is constant for any one setting.

The shunt is held in any desired position by pressure from a curved arm made of sheet spring steel, which is fastened to the bottom of the coil frame at the rear of the shunt. This spring arm is shaped to extend around the shunt to the front of the relay, and in its normal position it exerts sufficient pressure against the shunt to prevent any creeping of the shunt or undesired change of setting. The front end of the spring arm has a bent-over tab on which thumb-pressure may be applied to move the arm out of contact with the shunt while the position of the latter is being changed.

The stationary contacts are assembled on slotted brackets. These are held in position on the base by filister-head screws which are threaded into the terminal inserts. Lock-washers are assembled inside the moulded terminal bushings between the inserts and the base, as a safeguard against loosening of the screws. By rotating the bracket on its mounting screw and moving it along its slot, the contact assembly can be made either normally open or normally closed. The moving contacts are mounted on a Micarta insulation plate which is secured to the threaded end of the plunger shaft by a nut. The front edge of this insulation plate operates the indicator. The rear portion of the plate is slotted and a post screwed to the frame passes through this slot to prevent the plate from rotating.

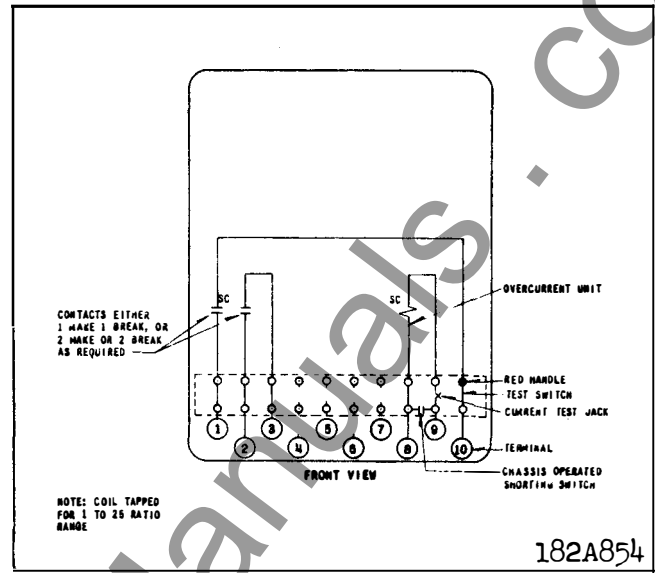

Fig. 2. Internal Schematic of the Single Unit Type SC or SC-1 Relay in The Type FT21 Case.

The moving contacts are double-faced so that they can be 'make' or 'break' and are connected to the base terminals by flexible leads. All contacts are pure silver. The contacts will carry 5 amperes continuously, and will interrupt 5 amperes at 115 volts A-C, or 1 ampere at 125 volts D-C.

The mechanical operation indicators used on these relays are shockproof, and can be used to indicate on the up stroke or down stroke of the plunger. The indicator is reset by pulling out the knurled stud which projects through the cover nut. The indicator should be reset after each relay operation because otherwise there may be a one or two percent decrease in the operating value of the relay. The operation indicator is assembled at the factory to indicate on the up stroke of the plunger, but by removing the two mounting screws which fasten the indicator to the main frame, turning the indicator bracket around and at the same time swinging the indicator flag 180° about its shaft, the indicator can be set to indicate on the down stroke of the plunger. The rivet weight must be removed from the indicator flag and the latch screen turned around to complete the assembly.

In certain applications, an extremely wide range of current adjustment is desirable, and certain styles of SC and SC-1 relays have been provided with tapped coils to meet this requirement. The coil taps are brought out to a tap block mounted on the lower end of the relay frame or on the relay sub-base, depending on the type of case used. The connector plate on the tap block is marked with the minimum pick-up value of

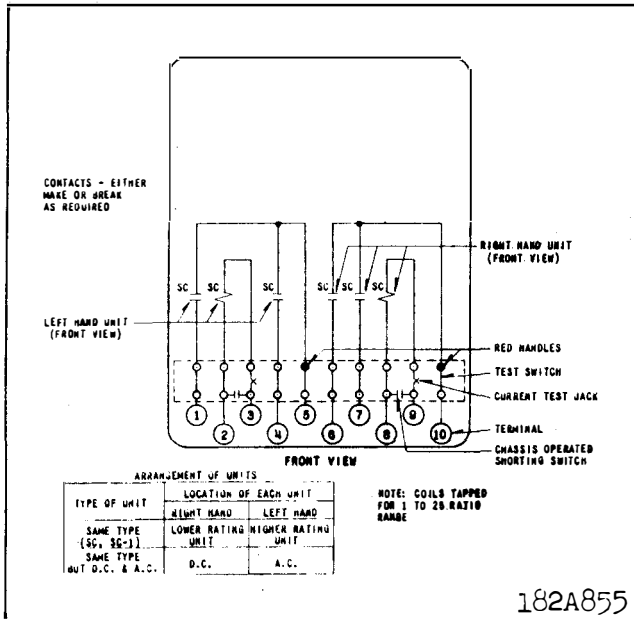

Fig. 3. Internal Schematic of the Double Unit Type SC or SC-1 Relay in the Type FT21 Case.

each tap, and the shunt is adjusted in the usual manner to obtain any pick-up setting between taps. The scale plate is not calibrated for the relays with tapped coils, as there is not sufficient space for marking a scale for each tap. However, the scale plate is supplied in order that a customer may mark on it the individual relay setting or settings if desired.

INSTALLATION

The relays should be mounted on switchboard panels or their equivalent in a location free from dirt, moisture, excessive vibration, and heat. Mount the relay vertically by means of the four mounting holes on the flange for semi-flush mounting or by means of the rear mounting stud or studs for projection mounting. Either a mounting stud or the mounting screws may be utilized for grounding the relay. The electrical connections may be made directly to the terminals by means of screws for steel panel mounting or to the terminal studs furnished with the relay for thick panel mounting. The terminal studs may be easily removed or inserted by locking two nuts on the stud and then turning the proper nut with a wrench.

For detailed FT case information refer to I.L. 41-076.

ADJUSTMENTS AND MAINTENANCE

The proper adjustments to insure correct operation of this relay have been made at the factory and

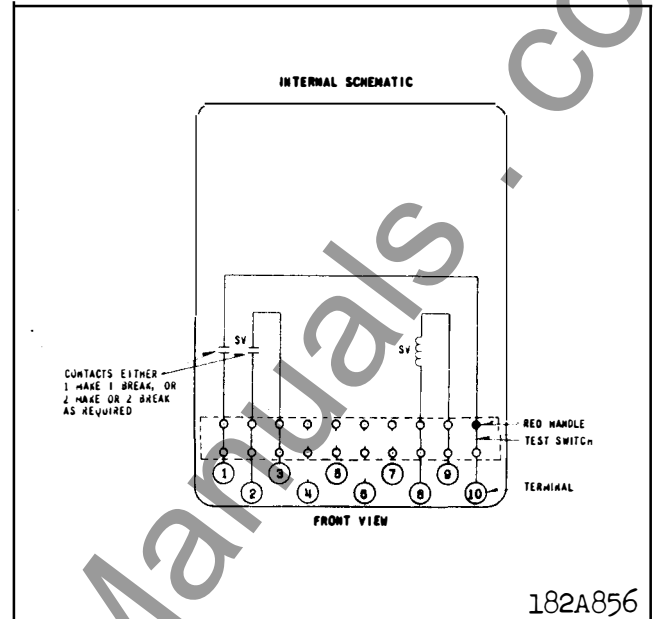

Fig. 4. Internal Schematic of the Single Unit Type SV or SV-1 Relay in the Type FT21 Case.

should not be disturbed after receipt by the customer. If the adjustments have been changed, the relay taken apart for repairs, or if it is desired to check the adjustments at regular maintenance periods, the instructions below should be followed.

All contacts should be cleaned periodically. A contact burnisher S#182A836H01 is recommended for this purpose. The use of abrasive material for cleaning contacts is not recommended, because of the danger of embedding small particles in the face of the soft silver and thus impairing the contact.

Several factors may affect the drop-out ratio of the relay. Whatever affects the ratio does so because either the drop-out or pick-up or both are affected. Obviously, incorrect assembly or interchange of parts, such as the use of the SC plunger with the SV core tube, will alter the electrical characteristics. However, the factor most likely to be encountered in service is friction. This may be due to dirt or foreign material between the plunger shaft and its bearings, to excessive pressure of the indicator screen on the indicator, or to leads so mis-shaped that they tend to rotate or tilt the moving contact insulation plate with appreciable force.

In order to remove the plunger and shaft assembly, it is necessary to remove the setscrew and nut at the top of the shaft. The spool-shaped bushing assembled on the upper end of the plunger shaft has a portion of

TYPES SC, SC-1, SV AND SV-1 RELAYS

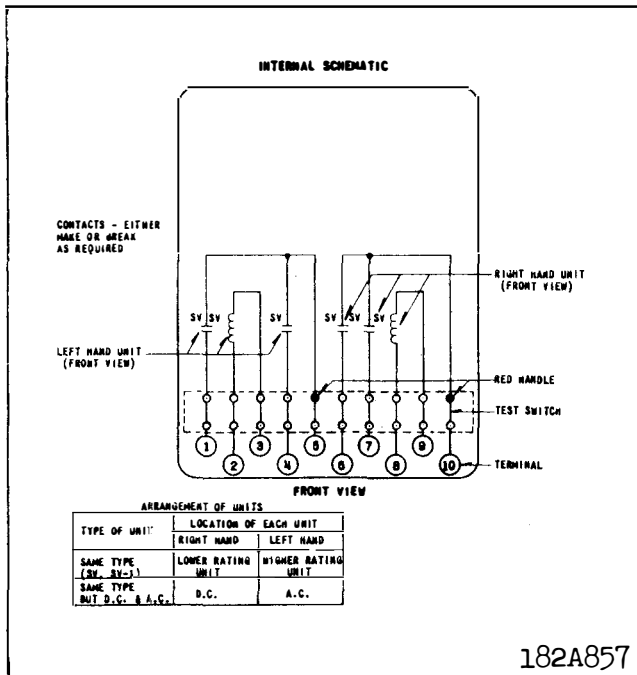

Fig. 5. Internal Schematic of the Double Unit Type SV or SV-1 Relay in the Type FT32 Case.

its center section machined off so that the shaft is exposed at this point and can be prevented from turning by gripping shaft and bushing with a pair of long-nose pliers while removing the set screw and nut. Then by pressing down with the fingers on the upper end of the shaft, the lower split sleeve which retains the lower bearing will be forced out of the threaded tube, the bearing will drop out freely, and the upper split sleeve will be forced out far enough to permit grasping it for removal. The shaft and plunger assembly then can be removed.

The shaft and plunger assembly should be handled carefully to avoid bending the shaft or damaging the bearing surfaces. The shaft should never be gripped on its upper bearing surface, below the spool-shaped bushing, when loosening the nut and setscrew, as this would almost certainly damage the bearing surface. The shaft bearing surfaces should not be cleaned or polished with any abrasive material, as the abrasive particles might become imbedded in the shaft and cause difficulty later. The plunger shaft and bearings may be cleaned by wiping them carefully with a clean, lint-less cloth. This may be moistened with benzene or some other cleaning solvent if necessary. Use no lubricant on the plunger shaft or bearings when re-assembling the relay, since this will eventually become gummy and prevent proper operation. It is recommended that the shaft be clean-

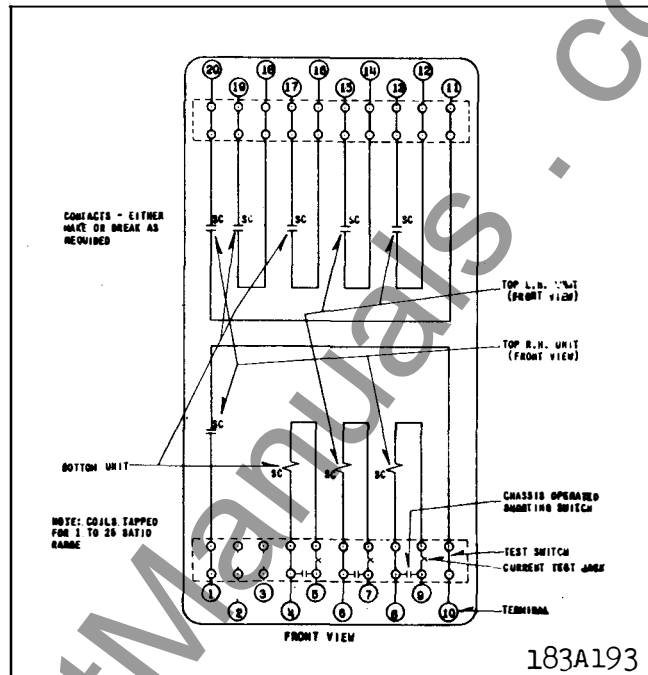

Fig. 6. Internal Schematic of the Three Unit Type SC or SC-1 Relay in the Type FT32 Case.

ed at intervals of approximately two years. When replacing the lower bearing and the split sleeves, the shorter sleeve (assembled below the bearing) should be pushed in until it is flush with the end of the threaded tube.

The mounting holes in the operation indicator screen are slotted so that its position can be adjusted. For relays in which the moving contacts are not latched in the operated position, the screen should be so located that the indicator positively enters the screen opening when the contacts barely touch. For latch-type relays, the screen should be so located that good contact is still obtained when the relay is de-energized. The pressure of the screen against the indicator may be adjusted by bending the screen between its lower end and the large elongated hole. This pressure should be such that the indicator will be held at any further position to which it is moved after entering the screen opening. However, the minimum amount of pressure necessary to obtain this adjustment should not be exceeded appreciably, since the pick-up value, and consequently the ratio, will be affected. The purpose of this pressure is to eliminate indicator rattle which might otherwise occur under certain energized conditions.

The moving contact leads pass through insulation sleeves assembled on the shanks of the terminal clips

CHARACTERISTICS OF TYPES SC AND SC-1 RELAYS

Type	Frequency	Range of Adjustment Amps.	Max. Amps. Continuous	Watts 5 Amps. 60 Cycles	V.A. at 5 Amps. 60 Cycles	Dropout Ratio-AC	Dropout Ratio-DC
SC	DC, 25 to 60 hz.	.5-2	1.5	99	225	90-98%	65-80%
SC	DC, 25 to 60 hz.	1-4	3	28	65	90-98%	65-80%
SC	DC, 25 to 60 hz.	2-8	6	6.9	19	90-98%	65-80%
SC	DC, 25 to 60 hz.	4-16	12	1.5	5	90-98%	65-80%
SC	DC, 25 to 60 hz.	10-40	25	.24	.7	90-98%	65-80%
SC	DC, 25 to 60 hz.	20-80	40	.07	.16	90-98%	65-80%
SC	DC, 25 to 60 hz.	40-160	40	.03	.05	90-98%	65-80%
SC	DC, 25 to 60 hz.	4-100*	10-15-20	1.7-0.6-0.18	5-1-0.2	90-98%	65-80%
SC-1	DC, 25 to 60 hz.	.5-2	1.5	100	210	35-60%	25-40%
SC-1	DC, 25 to 60 hz.	1-4	3	24	60	35-60%	25-40%
SC-1	DC, 25 to 60 hz.	2-8	6	6	16	35-60%	25-40%
SC-1	DC, 25 to 60 hz.	4-16	12	1.5	5	35-60%	25-40%
SC-1	DC, 25 to 60 hz.	10-40	25	.25	.65	35-60%	25-40%
SC-1	DC, 25 to 60 hz.	20-80	40	.07	.16	35-60%	25-40%
SC-1	DC, 25 to 60 hz.	40-160	40	.03	.05	35-60%	25-40%
SC-1	DC, 25 to 60 hz.	4-100*	10-15-20	1.7-0.6-0.18	5-1-0.2	35-60%	25-40%

* Coil has taps on which minimum pickups are 10 and 30 amperes.

CHARACTERISTICS OF SV AND SV-1 RELAYS

Type	Frequency (Cycles)	Range of Adjustment Volts	Max. Volts Continuous	Watts at 115 V. AC (125 V. for DC)	V.A. at 115 V.	Dropout Ratio
SV	60	7-16	16	-	-	90-98%
SV	60	70-160	160	3.4	7.3	90-98%
SV	60	140-320	320	-	-	90-98%
SV	60	280-640	640	-	-	90-98%
SV	50	70-160	180	2.8	6.1	90-98%
SV	25	70-160	200	1.5	2.5	90-98%
SV	DC	50-150	150	4.8	-	65-80%
SV	DC	100-300	300	-	-	65-80%
SV-1	60	7-16	16	-	-	40-80%
SV-1	60	70-160	160	4.1	8.5	40-80%
SV-1	60	140-320	320	-	-	40-80%
SV-1	60	280-640	640	-	-	40-80%
SV-1	50	70-160	180	3.5	7.1	40-80%
SV-1	25	70-160	200	1.4	3.2	40-80%
SV-1	DC	50-150	150	4.8	-	25-40%
SV-1	DC	100-300	300	-	-	25-40%

NOTES:--Standard current relays are calibrated on 60 cycles. This calibration is approximately correct for 25 cycle and DC applications, but there will be discrepancies of 10% to 15% at some points of scale.

Values of watts and volt-amperes in the tables are average for various plunger and shunt position.

For the SC relay, volt-amperes for pickup at minimum setting are approximately 3.4 and 1.4 for 60 and 25 cycles. Watts at minimum setting are approximately 1.0, .65 and .57 for 60 cycles, 25 cycles and DC respectively. Multiply values by 16 for approximate burdens at maximum setting.

For the SC-1 relay, volt-amperes for pickup at minimum setting are approximately 3.5 and 1.3 for 60 and 25 cycles. Watts at minimum settings are 1.3, .7 and .57 for 60 cycles, 25 cycles and d-c respectively. Multiply values by 16 for approximate burdens at maximum setting.

*The V.A. burdens of the SC and SC-1 relays at 3, 10 and 20 times minimum pickup current are approximately 31, 240 and 770 V.A. respectively.

Dropout ratio varies somewhat with pickup adjustment but will be approximately constant for any given pickup setting. Limits in tables include variables such as friction and other individual relay variations.

Maximum continuous volts given for the SV and SV-1 relays for A-C are for the relay set for minimum pickup. With the relay set for maximum pickup the continuous voltage can be increased 10 to 20%.

TYPES SC, SC-1, SV AND SV-1 RELAYS

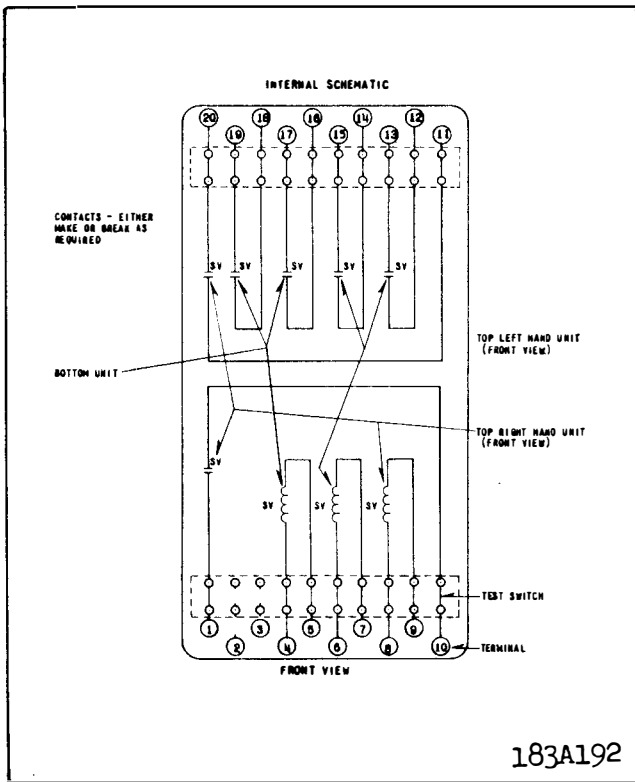

Fig. 7. Internal Schematic of the Three Unit Type SV or SV-1 Relay in the Type FT32 Case.

which are attached to the base terminals. These sleeves are notched at their upper ends, and the notches are toward the center of the relay. The leads are bent at approximately a right angle where they pass out through the notches, which aids in preventing them from coming into contact with the stationary contact brackets. Figure 11 shows properly coiled and assembled moving contact leads.

Although the moving contact leads are very flexible, if the leads have been pulled out of their original shape by handling they may exert sufficient side pressure on the shaft bearing or twisting force against the guide post to cause appreciable friction and wear. If this condition continues for a long period of time, the resulting wear may affect the relay calibration or the dropout ratio noticeably. In extreme cases the wear may progress to a degree which may occasionally cause failure of the plunger to drop down when the relay is de-energized.

Correct shaping of the leads is not difficult, and they may be checked readily by removing the guide post and the nut at the top of the shaft. The plunger should be held in the raised position, either by energizing the relay or by pressing lightly against the

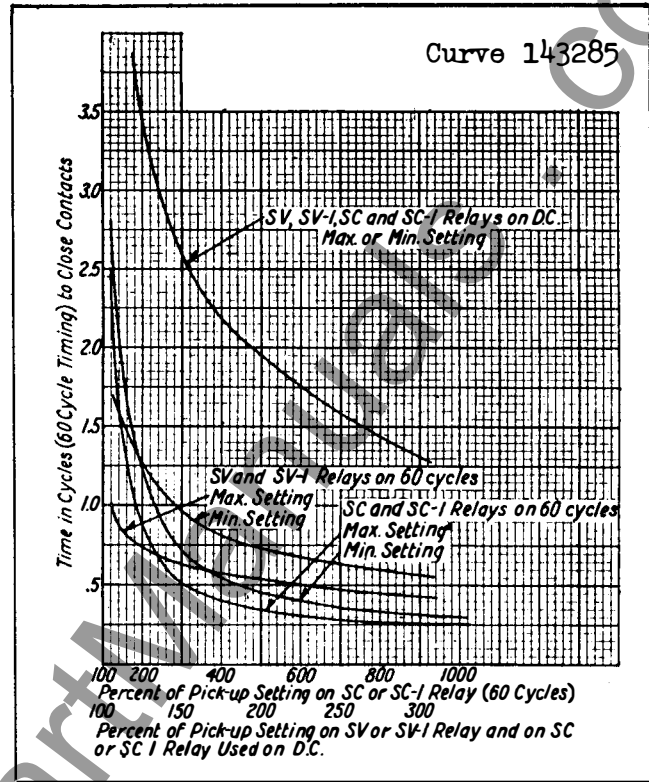

Fig. 8. Typical Time Curves for the Types SC and SV Relays (Using Flux Shunt for Pick-up Adjustment.)

collar under the insulation plate after raising the plunger manually. With the plunger raised, the insulation plate should be oscillated slightly in a horizontal plane by twisting it horizontally and releasing it. If in several trials the plate comes to rest with the center line of the contacts approximately parallel to the base and with its mounting hole fairly well centered with the end of the shaft, if the plate does not tip appreciably, and if the leads have a safe clearance to the stationary contact brackets, the leads are properly shaped.

If this check shows that re-shaping is necessary, it may be possible to obtain sufficient correction by bending the leads sharply where they emerge from the insulation sleeves. One or two pairs of tweezers are tools for re-shaping the leads. If it is necessary to re-coil the leads, they should be wound around a rod having a diameter of approximately 5/32". The coils then should be stretched out just enough to avoid side pull or twisting force on the plunger assembly.

In all relays except the SV-1 relay for A-C, if the stationary contacts are assembled so that they close when the relay is energized, they should be located so that they barely touch the moving contacts when

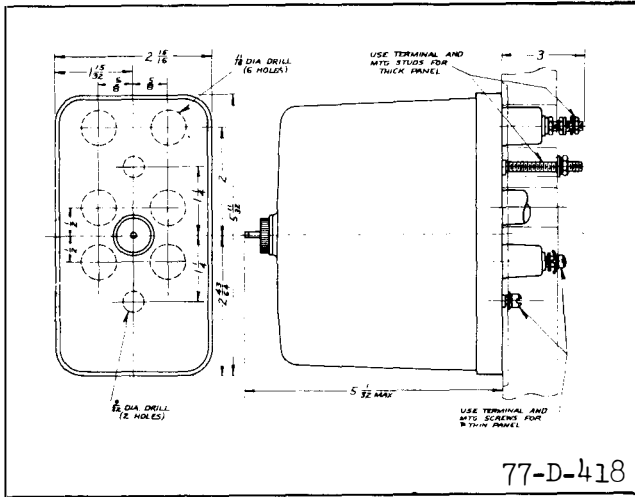

Fig. 9. Outline & Drilling Plan for Single Unit Relays in Small Glass Projection Case.

the latter are $5/32''$ above the de-energized position. The moving contacts can be held in this position while the adjustment is being made by inserting a $5/32''$ spacer between the shaft collar and the top of the core. This dimension should be $3/16''$ on the SV-1 relay for A-C. Both contacts should touch at the same time when the plunger is raised. When the plunger is moved upward against its stop, there should be a slight deflection of the stationary contact stop springs, but this should not exceed $1/32''$. When the stationary contacts are reversed so that they are closed when the relay is de-energized, they should be located so that they just touch the moving contacts when the latter are $1/32''$ above the de-energized position. On some relays it may be found that when the contacts are used in this position the relay may operate at values a few percent below the scale markings. The adjustments specified for the stationary contacts are important. Failure to observe them may cause improper relay operation, either directly or after a period of service. Contact position should not be used as a



Fig. 10. View of Type SC Relay Showing Correct Shaping of Moving Contact Leads.

means of altering the ratio of dropout to pickup.

RENEWAL PARTS

Repair work can be done most satisfactorily at the factory. However, interchangeable parts can be furnished to the customers who are equipped for doing repair work. When ordering parts, always give the complete nameplate data.

TYPES SC, SC-1, SV AND SV-1 RELAYS

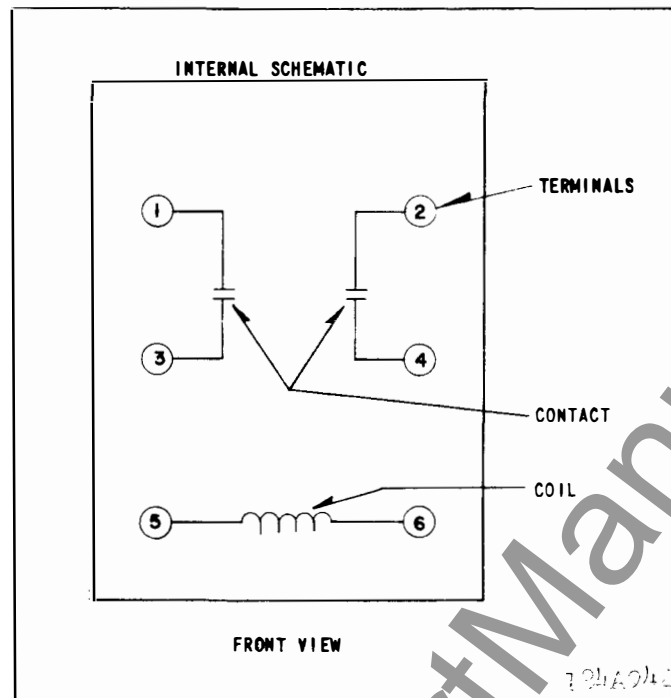

Fig. 11. Internal Schematic for Relays in Front Connected Case.

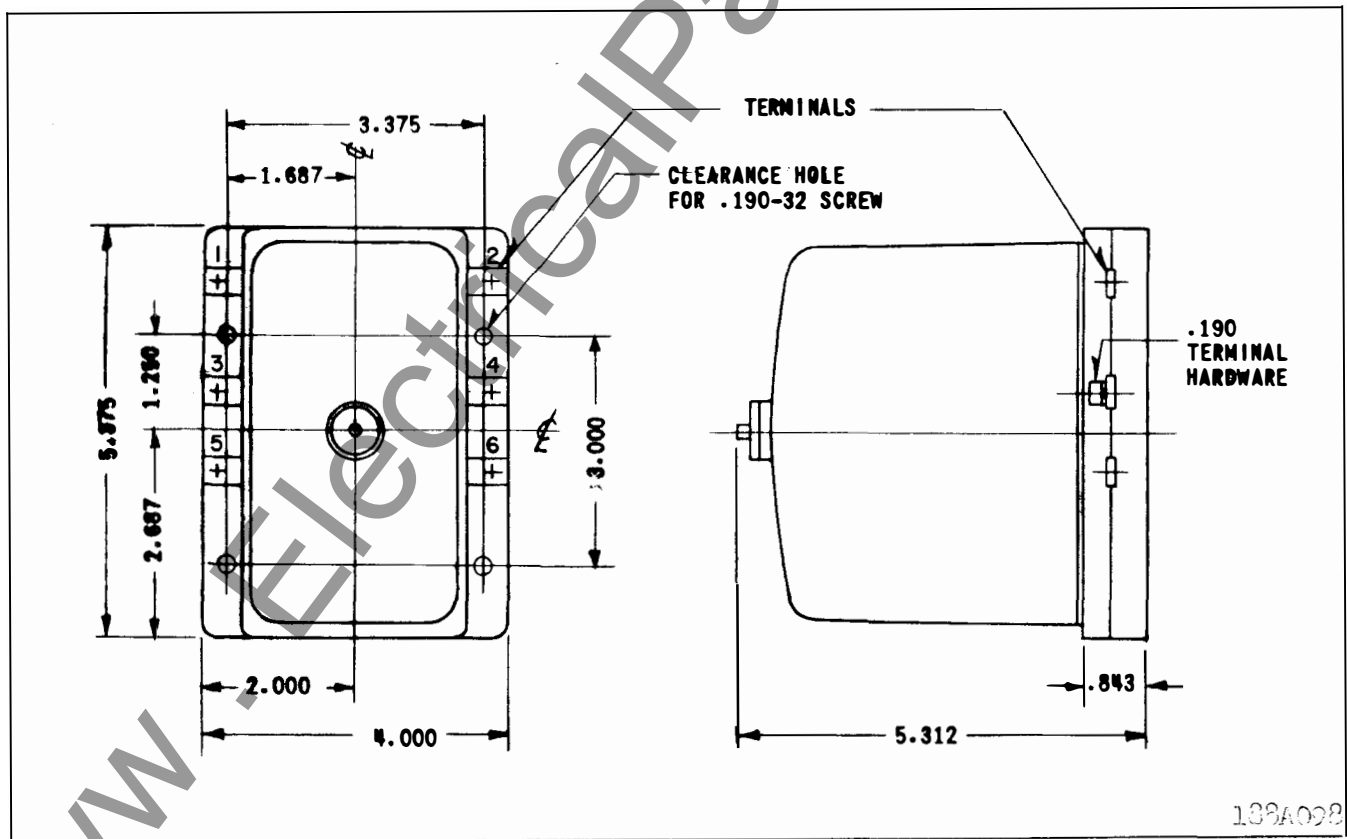
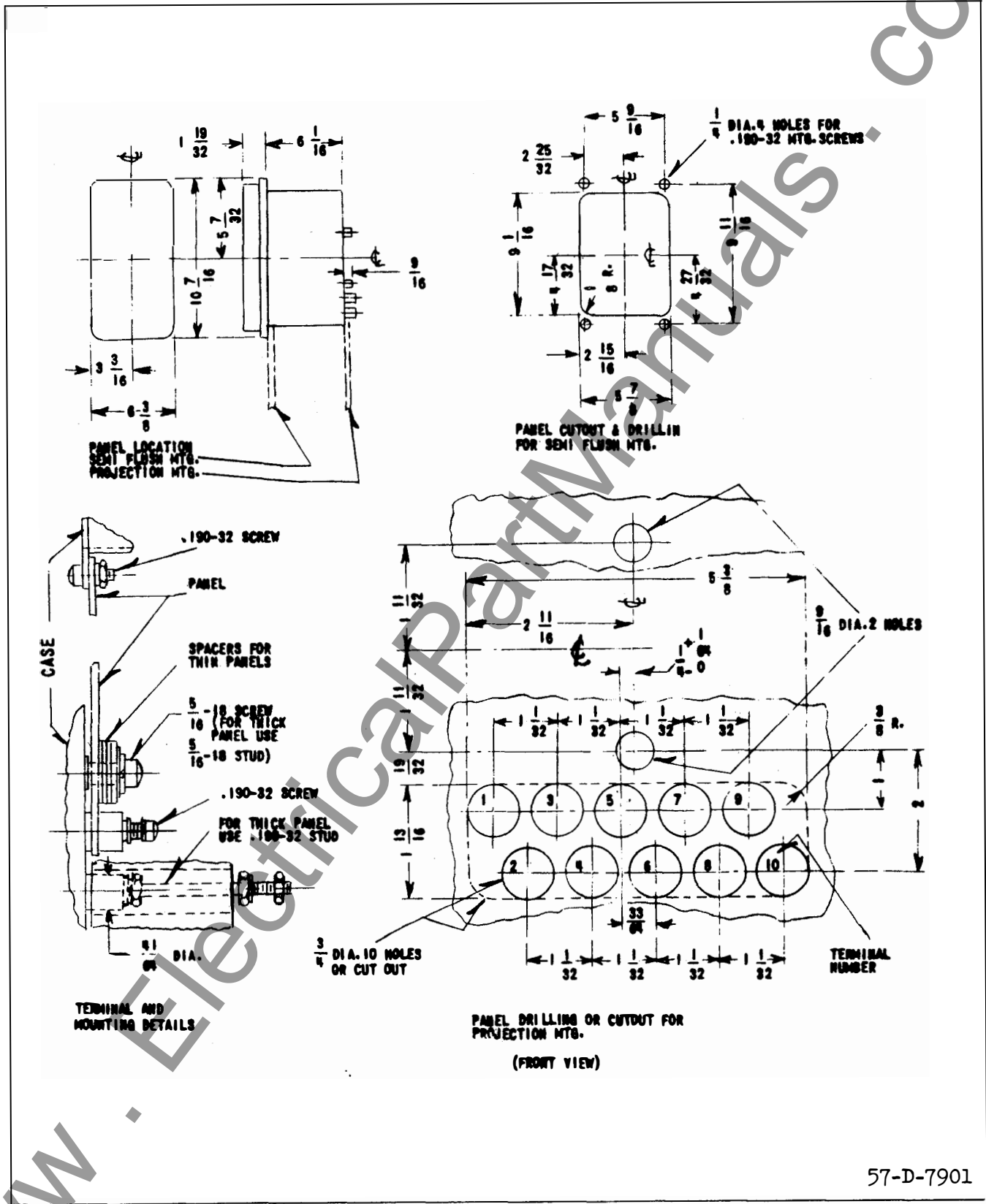
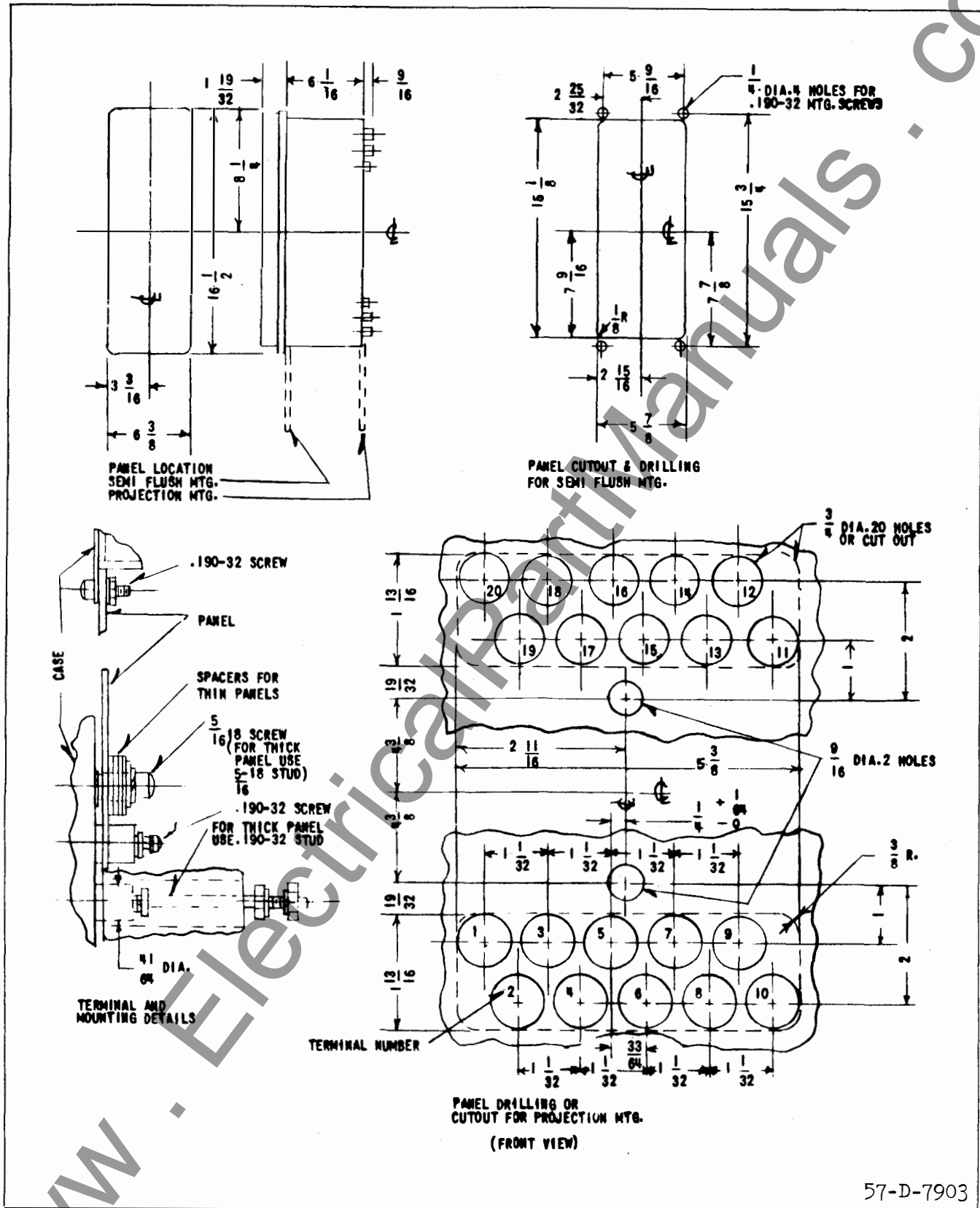

Fig. 12. Outline and Drilling Plan for Relays in Front Connected Case.



57-D-7901

Fig. 13 Outline and Drilling Plan for Single and Double Unit Relays in the Type FT21 Case.



57-D-7903

Fig. 14. Outline and Drilling Plan for Three Unit Relays in the Type FT32 Case.

www.ElectricalPartManuals.com

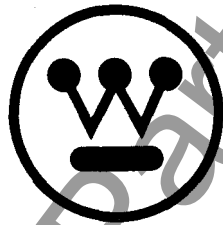

WESTINGHOUSE ELECTRIC CORPORATION
RELAY-INSTRUMENT DIVISION

NEWARK, N. J.

Printed in U.S.A.