



INSTALLATION • OPERATION • MAINTENANCE INSTRUCTIONS

TYPES HRK AND HRP CARRIER DIRECTIONAL OVERCURRENT GROUND RELAYS (WITH TYPE HL-2 DIRECTIONAL ELEMENT)

CAUTION Before putting protective relays into service, remove all blocking which may have been inserted for the purpose of securing the parts during shipment, make sure that all moving parts operate freely, inspect the contacts to see that they are clean and close properly, and operate the relay to check the settings and electrical connections.

APPLICATION

These relays are used to provide directional ground fault protection in the carrier relaying scheme using plate keyed carrier sets. The type HRK relay is used where residual current from the power transformer banks is available for polarizing the directional element. The type HRP relay is used where this residual current is not available, and residual voltage must be used for polarizing the element.

CONSTRUCTION AND OPERATION

These relays consist of two beam-type overcurrent unit, a directional unit, and an indicating contactor switch. The trip circuit of the relay includes the directional contacts in series with the contacts of one overcurrent unit, the operation indicator, and the contactor switch. The other overcurrent unit is used to start carrier signal transmission. Operation of this relay in connection with the carrier scheme is fully described in I. L. 41-904.

Overcurrent Unit

The construction details of the two overcurrent unit are shown in Figure 1. The element consists of a pivoted beam with contact arm on one end and a restraining spring acting on the other. The beam is pulled down to make contact by a current coil, and resets through the action of the restraining spring.

The moving contact is a thin-walled silver

shell practically filled with tungsten powder. When this contact strikes the rigid stationary contact, the movement of the tungsten powder creates sufficient friction to absorb practically all of the energy of impact and thus the tendency of the contact to bounce is reduced to a minimum. The moving contact is loosely mounted on the beam and held in place by a leaf spring. The construction is such that the beam continues to move slightly after the contacts close deflecting the spring. This provides the required contact follow. Current is conducted into the moving contact by means of a flexible metal ribbon.

Directional Unit

The directional unit is made up of five basic parts: the die-cast aluminum frame, the electromagnet, the molded cover assembly, the moving element assembly, and the bridge and upper bearing pin assembly. The lower bearing pin and the magnetic core with its adjustment lever are mounted on the frame. The electromagnet has two series-connected polarizing coils mounted diametrically opposite one another, two series-connected current coils mounted diametrically opposite one another and two magnetic plugs accessible through the cover. The moving element consists of a spring and contact arm assembly and a double aluminum loop mounted on a shaft which has end jewels for the top and bottom bearings. This shaft rides between the bottom steel bearing pin mounted in the frame and a similar pin in the bridge that mounts on the two longer studs of the electromagnet. The stops for the moving element are mounted on the cover and are easily accessible for the adjustment of the contact travel. The spring adjuster seats on the molded cover and is attached to the contact through a spiral spring. The moving contact is made of two thin-walled silver shells practically filled with tungsten powder and mounted back to back

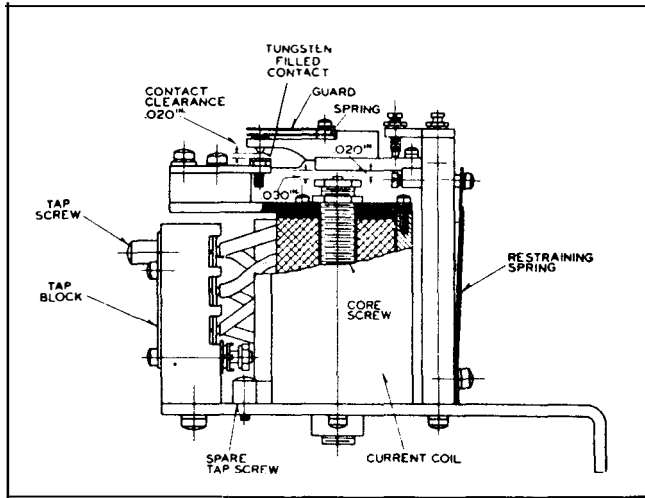

Fig. 1 Sectional View of the Overcurrent Units.

on a thin leaf spring. The stationary silver contacts are mounted on the molded cover. The electrical connection is made from the stationary contact to the moving contact, through the spiral and spring adjuster to the spring adjuster to the spring adjuster clamp. The flux in each pole face is lagged on the outside edges by copper loops. This produces a torque that counter-balances the centering torque, caused by the small power factor angle of the moving element.

The torque of the unit is produced by the interaction of the current and flux which develops forces on the two aluminum loops. The resulting torque is substantially free of vibrations, because the double-frequency torques that are produced on the two loops are equal and opposite in sign. The flux in each pole face is lagged on the outside edges. This produces a torque that counter-balances the centering torque, caused by the small power factor angle of the moving element.

Indicating Contactor Switch Unit (ICS)

The d-c indicating contactor switch is a small clapper type device. A magnetic armature, to which leaf-spring mounted contacts are attached, is attracted to the magnetic core upon energization of the switch. When the switch closes, the moving contacts bridge two stationary contacts, completing the trip circuit. Also during this operation two fingers on the armature deflect a spring located on the front of the switch, which allows the operation indicator target to drop. The target is reset from the

outside of the case by a push rod located at the bottom of the cover.

The front spring, in addition to holding the target, provides restraint for the armature and thus controls the pickup value of the switch.

CHARACTERISTICS AND SETTINGS

The overcurrent unit of the relays operates in one cycle or less on values of ground fault current above 200% of the tap setting. The taps available are:

- 0.5, 0.75, 1.0, 2.0, 4.0, 6.0.

The settings should be made by inserting the tap screw in the tap to give the required pick-up.

The carrier - start overcurrent unit at each line terminal is set on a lower tap than the tripping element at either end of the line. This arrangement insures proper blocking for remote external faults which may not pick up both overcurrent elements at each line terminal.

Select a tap for the tripping overcurrent unit (left-hand, front view) which will allow tripping the minimum internal ground fault. Set the carrier-start unit (right-hand, front view) on the next lower tap.

The HRK relay is designed for current polarization with maximum torque occurring when the operating current leads the polarizing current 30° to 35°. The minimum pick-up has been set by the spring tension to be approximately 1.0 ampere when current circuits are connected in series. Greater sensitivity may be obtained by decreasing the spring tension; however, this will also decrease the restoring force when the unit is de-energized.

The HRP relay is designed for potential polarization with an internal phase shifter so that the maximum torque occurs when the operating current lags the residual voltage by approximately 60 degrees. The minimum pick up has been set by the spring tension to be approximately 2.5 volts and 4 ampere at maximum torque.

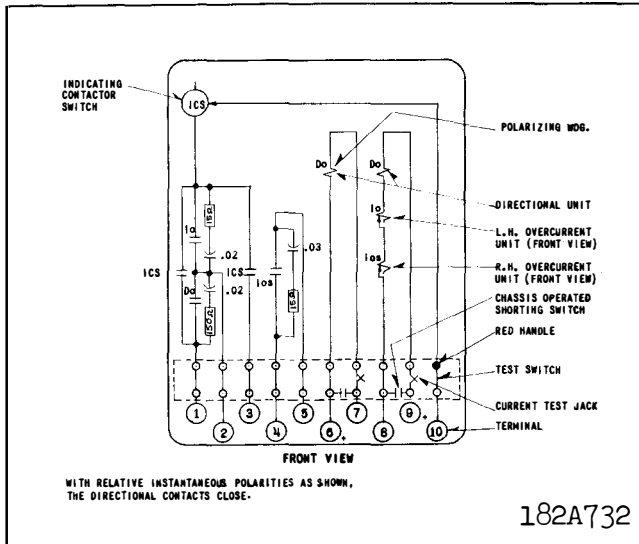

Fig. 2 Internal Schematic of the Type HRK Relay in the Type FT31 Case.

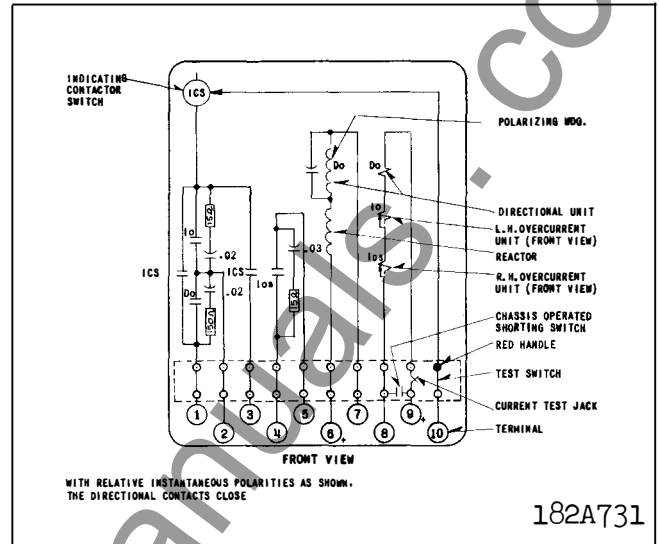

Fig. 3 Internal Schematic of the Type HRP Relay in the Type FT31 Case.

Trip Circuit

The main contacts will safely close 30 amperes at 250 volts d-c and the seal-in contacts of the indicating contactor switch will safely carry this current long enough to trip a circuit breaker.

The indicating contactor switch has two taps that provide a pickup setting of 0.2 or 2 amperes. To change taps requires connecting the lead located in front of the tap block to the desired setting by means of a screw connection. No other settings are required. Set in the 0.2 tap if energizing a WL relay switch or equivalent.

Trip Circuit Constant

Indicating Contactor Switch (ICS)

- 0.2 ampere tap 6.5 ohms d-c resistance
- 2.0 ampere tap 0.15 ohms d-c resistance

INSTALLATION

The relays should be mounted on switchboard panels or their equivalent in a location free from dirt, moisture, excessive vibration, and heat. Mount the relay vertically by means of the four mounting holes on the flange for semi-flush mounting or by means of the rear mounting stud or studs for projection mounting. Either a mounting stud or the mounting screws

may be utilized for grounding the relay. The electrical connections may be made directly to the terminals by means of screws for steel panel mounting or to the terminal studs furnished with the relay for thick panel mounting. The terminal studs may be easily removed or inserted by locking two nuts on the stud and then turning the proper nut with a wrench.

For detailed FT case information refer to I.L. 41-076.

The a-c external schematics of both the type HRK and HRP relays are shown in Figures 4 and 5. The carrier relaying d-c schematic (supplied with all carrier orders) should be consulted for the details of the external d-c connections of these relays.

ADJUSTMENTS

The proper adjustments to insure correct operation of this relay have been made at the factory and should not be disturbed after receipt by the customer. If the adjustments have been changed, the relay taken apart for repairs, or if it is desired to check the adjustments at regular maintenance periods, the instructions below should be followed.

All contacts should be cleaned periodically. A contact burnisher S#182A836H01 is recommended for this purpose. The use of abrasive

TYPES HRK AND HRP RELAYS

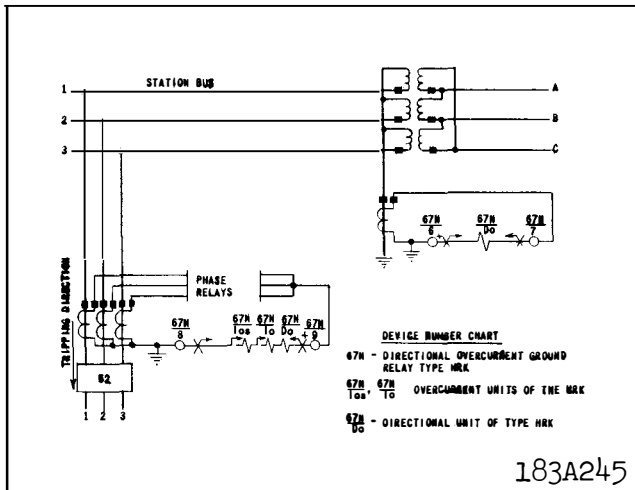

Fig. 4 External A-C Schematic of the Type HRK Relay.

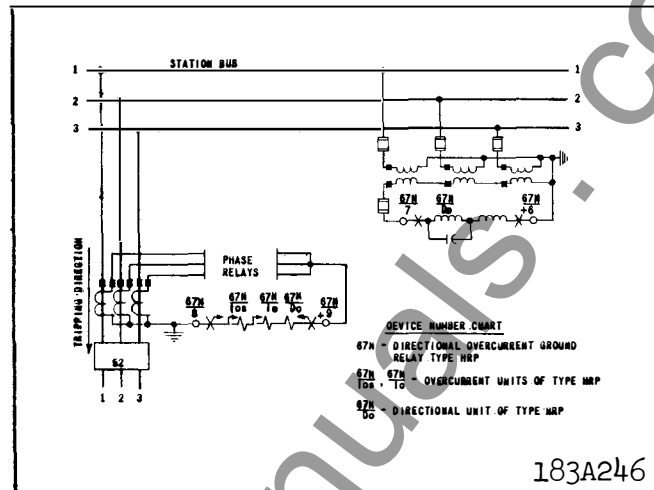

Fig. 5 External A-C Schematic of the Type HRP Relay.

material for cleaning contacts is not recommended, because of the danger of embedding small particles in the face of the soft silver and thus impairing the contact.

Overcurrent Units

Refer to Figure 1. Adjust the stop screw until the beam is in a horizontal position when resting against it. Adjust the magnetic gap to .020 inch. This is the gap between the beam and the stop pin. Adjust the stationary contact for an .020 inch gap when the beam is in the reset position. When the beam is in the operated position, there should be an .015 inch deflection of the moving contact. See that the spring which carries the moving element lies flat on the Micarta arm with no initial tension in either direction. Also, make sure that the flexible pigtail is at least 3/32 inch away from the end of the stationary contact.

Pass 0.5 ampere thru the unit with the tap screw in the 0.5 tap and adjust the beam spring tension until the beam just trips. This spring tension should hold the beam in the reset position, and when the beam is tripped on 0.5 ampere, the beam should deflect the moving contact spring and rest on the front stop pin. The tripping point of the other taps should be within $\pm 5\%$ of the tap values.

Directional Unit

The upper bearing screw should be screwed down until there is only three to four thou-

sandths of an inch clearance between it and the shaft, and then securely locked in position with the lock nut. This adjustment can be made best by carefully screwing down the top bearing screw until the double loop fails to turn freely and then backing up 1/8" of a turn. Great care must be taken in making this adjustment to prevent damage to the bearings.

The travel of the moving contact is limited by the stationary contacts mounted on the molded cover. The contact gap should be adjusted as follows: With the moving contact centered between the studs, close the contact gaps by advancing the two front stationary contacts. Then back off the right-hand stationary contact .035 inch and lock both contacts in place. The front contact spring should be positioned in the center of the .020 inch slot of the aluminum guard by means of the small adjusting screw located on the nut plate that holds the spring on the moving element. The complete moving element is limited in travel by two stop screws located on the molded cover assembly.

Type HRK relays only - The moving element stops should be adjusted so that the moving contact just touches the stationary contact when energized in the closing direction with 5.0 amperes in phase in the current circuits. The right-hand stationary contact should be turned 1/6th of a turn to obtain .005 inch contact follow. The rear and left stationary contact stops should be adjusted to barely miss the moving contact when energized as

above. Energize the unit in the opening direction by passing 60 amperes through the current circuits in series. The contact should not bounce closed when the element is suddenly de-energized. Slight readjustment of the left-hand stop may be necessary to insure that this does not happen. The magnetic plugs which are accessible through the molded cover are used to adjust for zero torque with current only in the operating coils. Raising the right-hand plug will produce torque to the right when considering the front moving contact.

Type HRP relays only - The moving element stops should be adjusted so that the moving contact just touches the stationary contact when energized in the closing direction with 120 volts and 5.0 amperes at 60 degrees lag. The right-hand stationary contact should then be turned 1/6th of a turn to obtain .005 inch contact follow. The rear and left stationary contact stops should be adjusted to barely miss the moving contact when energized as above. Energize the unit in the opening direction with 120 volts and 60 amperes at 240 degrees lag. The contact should not bounce closed when the unit is suddenly de-energized. Slight readjustment of the left-hand stop may be necessary to insure that this does not happen.

The lever at the bottom of the unit should be adjusted so that the unit will operate with 30 amperes and 0.1 to 0.4 volt at the maximum torque angle. Before or after this adjustment, short the voltage coils and check to insure that the contacts do not close on 60 amperes momentarily applied. Raising the right-hand plug under these conditions will produce torque to the right when considering the front moving contact. The unit can be adjusted to just remain open under these conditions or adjusted to operate with 60 amperes and 0.1 to 0.4 volts at the maximum torque angle.

Indicating Contactor Switch Unit (ICS)

Close the main relay contacts and pass sufficient d-c current through the trip circuit to close the contacts of the ICS. This value of current should not be greater than the particular ICS tap setting being used. The indicator target should drop freely.

RENEWAL PARTS

Repair work can be done most satisfactorily at the factory. However, interchangeable parts can be furnished to the customers who are equipped for doing repair work. When ordering parts, always give the complete name-plate data.

ENERGY REQUIREMENTS

The typical 60 cycle burdens of the various circuits of these relays are as follows:

HRP Relay Only

Directional element and overcurrent unit in series:

0.5 amp. tap at 0.5 amps.	.6 v.a.	41° lag
6.0 amp. tap at 6.0 amps.	3.8 v.a.	36° lag

Directional element polarizing circuit:

At 120 volts.	6.9 v.a.	42° lag
---------------	----------	---------

HRK Relay Only

Directional unit and overcurrent unit in series:

0.5 amp. tap at 0.5 amps.	.6 v.a.	41° lag
6.0 amp. tap at 6.0 amps.	6.7 v.a.	40° lag

Directional unit polarizing circuit:

At 5.0 amperes	4.8 v.a.	10° lag
----------------	----------	---------

www.ElectricalPartManuals.com



WESTINGHOUSE ELECTRIC CORPORATION
METER DIVISION

NEWARK, N.J.

Printed in U.S.A.



INSTALLATION • OPERATION • MAINTENANCE I N S T R U C T I O N S

TYPES HRK AND HRP CARRIER DIRECTIONAL OVERCURRENT GROUND RELAYS (WITH TYPE HL-2 DIRECTIONAL ELEMENT)

CAUTION Before putting protective relays into service, remove all blocking which may have been inserted for the purpose of securing the parts during shipment, make sure that all moving parts operate freely, inspect the contacts to see that they are clean and close properly, and operate the relay to check the settings and electrical connections.

APPLICATION

These relays are used to provide directional ground fault protection in the carrier relaying scheme using plate keyed carrier sets. The type HRK relay is used where residual current from the power transformer banks is available for polarizing the directional element. The type HRP relay is used where this residual current is not available, and residual voltage must be used for polarizing the element.

CONSTRUCTION AND OPERATION

These relays consist of two beam-type overcurrent unit, a directional unit, and an indicating contactor switch. The trip circuit of the relay includes the directional contacts in series with the contacts of one overcurrent unit, the operation indicator, and the contactor switch. The other overcurrent unit is used to start carrier signal transmission. Operation of this relay in connection with the carrier scheme is fully described in I. L. 41-904.

Overcurrent Unit

The construction details of the two overcurrent unit are shown in Figure 1. The element consists of a pivoted beam with contact arm on one end and a restraining spring acting on the other. The beam is pulled down to make contact by a current coil, and resets through the action of the restraining spring.

The moving contact is a thin-walled silver

shell practically filled with tungsten powder. When this contact strikes the rigid stationary contact, the movement of the tungsten powder creates sufficient friction to absorb practically all of the energy of impact and thus the tendency of the contact to bounce is reduced to a minimum. The moving contact is loosely mounted on the beam and held in place by a leaf spring. The construction is such that the beam continues to move slightly after the contacts close deflecting the spring. This provides the required contact follow. Current is conducted into the moving contact by means of a flexible metal ribbon.

Directional Unit

The directional unit is made up of five basic parts: the die-cast aluminum frame, the electromagnet, the molded cover assembly, the moving element assembly, and the bridge and upper bearing pin assembly. The lower bearing pin and the magnetic core with its adjustment lever are mounted on the frame. The electromagnet has two series-connected polarizing coils mounted diametrically opposite one another, two series-connected current coils mounted diametrically opposite one another and two magnetic plugs accessible through the cover. The moving element consists of a spring and contact arm assembly and a double aluminum loop mounted on a shaft which has end jewels for the top and bottom bearings. This shaft rides between the bottom steel bearing pin mounted in the frame and a similar pin in the bridge that mounts on the two longer studs of the electromagnet. The stops for the moving element are mounted on the cover and are easily accessible for the adjustment of the contact travel. The spring adjuster seats on the molded cover and is attached to the contact through a spiral spring. The moving contact is made of two thin-walled silver shells practically filled with tungsten powder and mounted back to back

TYPES HRK AND HRP RELAYS

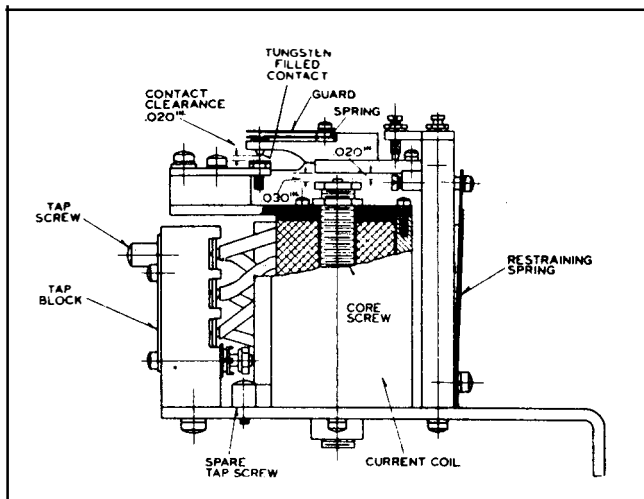

Fig. 1 Sectional View of the Overcurrent Units.

on a thin leaf spring. The stationary silver contacts are mounted on the molded cover. The electrical connection is made from the stationary contact to the moving contact, through the spiral and spring adjuster to the spring adjuster to the spring adjuster clamp. The flux in each pole face is lagged on the outside edges by copper loops. This produces a torque that counter-balances the centering torque, caused by the small power factor angle of the moving element.

The torque of the unit is produced by the interaction of the current and flux which develops forces on the two aluminum loops. The resulting torque is substantially free of vibrations, because the double-frequency torques that are produced on the two loops are equal and opposite in sign. The flux in each pole face is lagged on the outside edges. This produces a torque that counter-balances the centering torque, caused by the small power factor angle of the moving element.

Indicating Contactor Switch Unit (ICS)

The d-c indicating contactor switch is a small clapper type device. A magnetic armature, to which leaf-spring mounted contacts are attached, is attracted to the magnetic core upon energization of the switch. When the switch closes, the moving contacts bridge two stationary contacts, completing the trip circuit. Also during this operation two fingers on the armature deflect a spring located on the front of the switch, which allows the operation indicator target to drop. The target is reset from the

outside of the case by a push rod located at the bottom of the cover.

The front spring, in addition to holding the target, provides restraint for the armature and thus controls the pickup value of the switch.

CHARACTERISTICS AND SETTINGS

The overcurrent unit of the relays operates in one cycle or less on values of ground fault current above 200% of the tap setting. The taps available are:

0.5, 0.75, 1.0, 2.0, 4.0, 6.0.

The settings should be made by inserting the tap screw in the tap to give the required pick-up.

The carrier - start overcurrent unit at each line terminal is set on a lower tap than the tripping element at either end of the line. This arrangement insures proper blocking for remote external faults which may not pick up both overcurrent elements at each line terminal.

Select a tap for the tripping overcurrent unit (left-hand, front view) which will allow tripping the minimum internal ground fault. Set the carrier-start unit (right-hand, front view) on the next lower tap.

The HRK relay is designed for current polarization with maximum torque occurring when the operating current leads the polarizing current 30° to 35° . The minimum pick-up has been set by the spring tension to be approximately 1.0 ampere when current circuits are connected in series. Greater sensitivity may be obtained by decreasing the spring tension; however, this will also decrease the restoring force when the unit is de-energized.

The HRP relay is designed for potential polarization with an internal phase shifter so that the maximum torque occurs when the operating current lags the residual voltage by approximately 60 degrees. The minimum pick up has been set by the spring tension to be approximately 2.5 volts and 4 ampere at maximum torque.

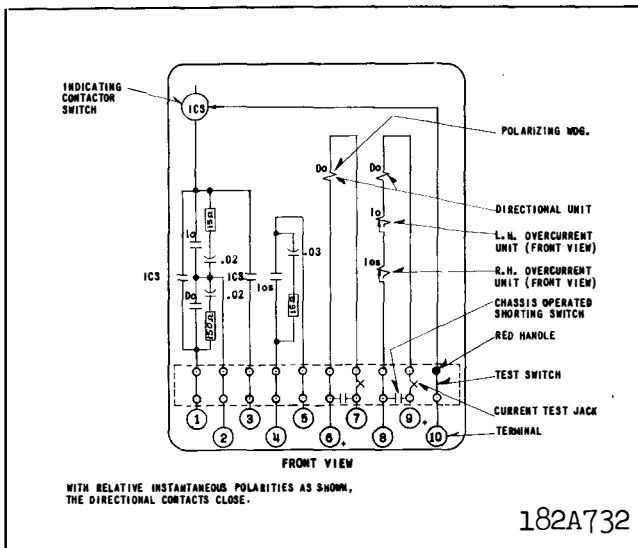

Fig. 2 Internal Schematic of the Type HRK Relay in the Type FT31 Case.

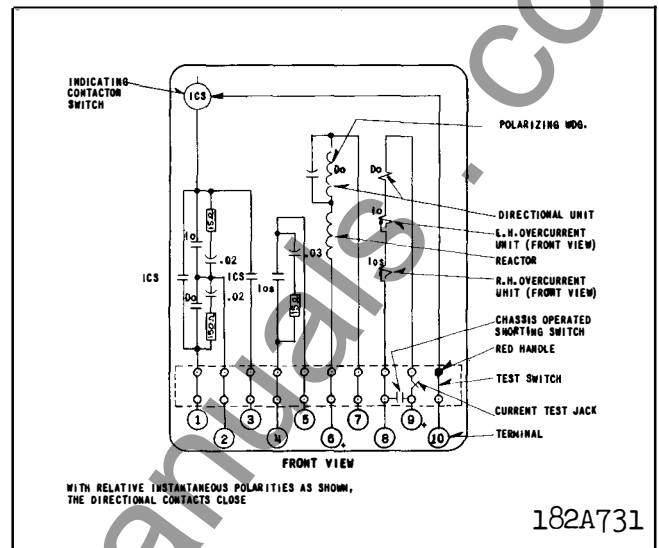

Fig. 3 Internal Schematic of the Type HRP Relay in the Type FT31 Case.

Trip Circuit

The main contacts will safely close 30 amperes at 250 volts d-c and the seal-in contacts of the indicating contactor switch will safely carry this current long enough to trip a circuit breaker.

The indicating contactor switch has two taps that provide a pickup setting of 0.2 or 2 amperes. To change taps requires connecting the lead located in front of the tap block to the desired setting by means of a screw connection.

* No other settings are required. Set in the 2.0 tap for all carrier relaying applications.

Trip Circuit Constant

Indicating Contactor Switch (ICS)

- 0.2 ampere tap 6.5 ohms d-c resistance
- 2.0 ampere tap 0.15 ohms d-c resistance

INSTALLATION

The relays should be mounted on switchboard panels or their equivalent in a location free from dirt, moisture, excessive vibration, and heat. Mount the relay vertically by means of the four mounting holes on the flange for semi-flush mounting or by means of the rear mounting stud or studs for projection mounting. Either a mounting stud or the mounting screws

may be utilized for grounding the relay. The electrical connections may be made directly to the terminals by means of screws for steel panel mounting or to the terminal studs furnished with the relay for thick panel mounting. The terminal studs may be easily removed or inserted by locking two nuts on the stud and then turning the proper nut with a wrench.

For detailed FT case information refer to I.L. 41-076.

The a-c external schematics of both the type HRK and HRP relays are shown in Figures 4 and 5. The carrier relaying d-c schematic (supplied with all carrier orders) should be consulted for the details of the external d-c connections of these relays.

ADJUSTMENTS

The proper adjustments to insure correct operation of this relay have been made at the factory and should not be disturbed after receipt by the customer. If the adjustments have been changed, the relay taken apart for repairs, or if it is desired to check the adjustments at regular maintenance periods, the instructions below should be followed.

All contacts should be cleaned periodically. A contact burnisher S#182A836H01 is recommended for this purpose. The use of abrasive

TYPES HRK AND HRP RELAYS

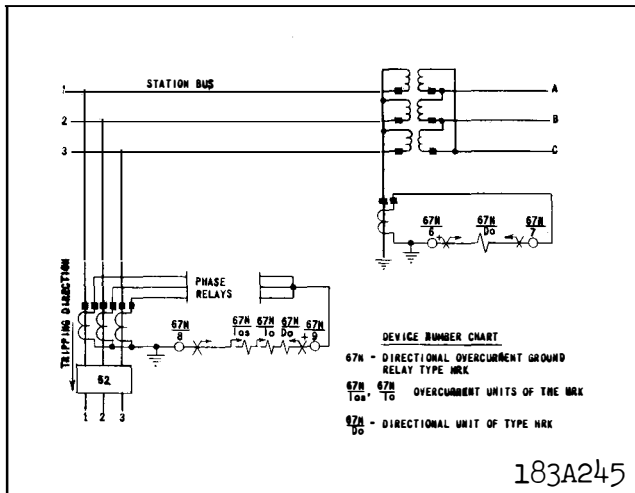

Fig. 4 External A-C Schematic of the Type HRK Relay.

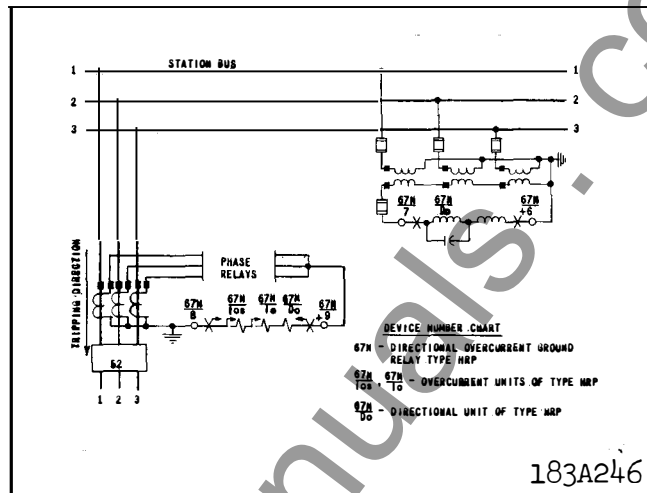

Fig. 5 External A-C Schematic of the Type HRP Relay.

material for cleaning contacts is not recommended, because of the danger of embedding small particles in the face of the soft silver and thus impairing the contact.

Overcurrent Units

Refer to Figure 1. Adjust the stop screw until the beam is in a horizontal position when resting against it. Adjust the magnetic gap to .020 inch. This is the gap between the beam and the stop pin. Adjust the stationary contact for an .020 inch gap when the beam is in the reset position. When the beam is in the operated position, there should be an .015 inch deflection of the moving contact. See that the spring which carries the moving element lies flat on the Micarta arm with no initial tension in either direction. Also, make sure that the flexible pigtail is at least 3/32 inch away from the end of the stationary contact.

Pass 0.5 ampere thru the unit with the tap screw in the 0.5 tap and adjust the beam spring tension until the beam just trips. This spring tension should hold the beam in the reset position, and when the beam is tripped on 0.5 ampere, the beam should deflect the moving contact spring and rest on the front stop pin. The tripping point of the other taps should be within $\pm 5\%$ of the tap values.

Directional Unit

The upper bearing screw should be screwed down until there is only three to four thou-

sandths of an inch clearance between it and the shaft, and then securely locked in position with the lock nut. This adjustment can be made best by carefully screwing down the top bearing screw until the double loop fails to turn freely and then backing up 1/8" of a turn. Great care must be taken in making this adjustment to prevent damage to the bearings.

The travel of the moving contact is limited by the stationary contacts mounted on the molded cover. The contact gap should be adjusted as follows: With the moving contact centered between the studs, close the contact gaps by advancing the two front stationary contacts. Then back off the right-hand stationary contact .035 inch and lock both contacts in place. The front contact spring should be positioned in the center of the .020 inch slot of the aluminum guard by means of the small adjusting screw located on the nut plate that holds the spring on the moving element. The complete moving element is limited in travel by two stop screws located on the molded cover assembly.

Type HRK relays only - The moving element stops should be adjusted so that the moving contact just touches the stationary contact when energized in the closing direction with 5.0 amperes in phase in the current circuits. The right-hand stationary contact should be turned 1/6th of a turn to obtain .005 inch contact follow. The rear and left stationary contact stops should be adjusted to barely miss the moving contact when energized as

above. Energize the unit in the opening direction by passing 60 amperes through the current circuits in series. The contact should not bounce closed when the element is suddenly de-energized. Slight readjustment of the left-hand stop may be necessary to insure that this does not happen. The magnetic plugs which are accessible through the molded cover are used to adjust for zero torque with current only in the operating coils. Raising the right-hand plug will produce torque to the right when considering the front moving contact.

Type HRP relays only - The moving element stops should be adjusted so that the moving contact just touches the stationary contact when energized in the closing direction with 120 volts and 5.0 amperes at 60 degrees lag. The right-hand stationary contact should then be turned 1/6th of a turn to obtain .005 inch contact follow. The rear and left stationary contact stops should be adjusted to barely miss the moving contact when energized as above. Energize the unit in the opening direction with 120 volts and 60 amperes at 240 degrees lag. The contact should not bounce closed when the unit is suddenly de-energized. Slight readjustment of the left-hand stop may be necessary to insure that this does not happen.

The lever at the bottom of the unit should be adjusted so that the unit will operate with 30 amperes and 0.1 to 0.4 volt at the maximum torque angle. Before or after this adjustment, short the voltage coils and check to insure that the contacts do not close on 60 amperes momentarily applied. Raising the right-hand plug under these conditions will produce torque to the right when considering the front moving contact. The unit can be adjusted to just remain open under these conditions or adjusted to operate with 60 amperes and 0.1 to 0.4 volts at the maximum torque angle.

Indicating Contactor Switch Unit (ICS)

Close the main relay contacts and pass sufficient d-c current through the trip circuit to close the contacts of the ICS. This value of current should not be greater than the particular ICS tap setting being used. The indicator target should drop freely.

RENEWAL PARTS

Repair work can be done most satisfactorily at the factory. However, interchangeable parts can be furnished to the customers who are equipped for doing repair work. When ordering parts, always give the complete name-plate data.

ENERGY REQUIREMENTS

The typical 60 cycle burdens of the various circuits of these relays are as follows:

HRP Relay Only

Directional element and overcurrent unit in series:

0.5 amp. tap at 0.5 amps.	.6 v. a.	41° lag
6.0 amp. tap at 6.0 amps.	3.8 v. a.	36° lag

Directional element polarizing circuit:

At 120 volts.	6.9 v. a.	42° lag
---------------	-----------	---------

HRK Relay Only

Directional unit and overcurrent unit in series:

0.5 amp. tap at 0.5 amps.	.6 v. a.	41° lag
6.0 amp. tap at 6.0 amps.	6.7 v. a.	40° lag

Directional unit polarizing circuit:

At 5.0 amperes	4.8 v. a.	10° lag
----------------	-----------	---------

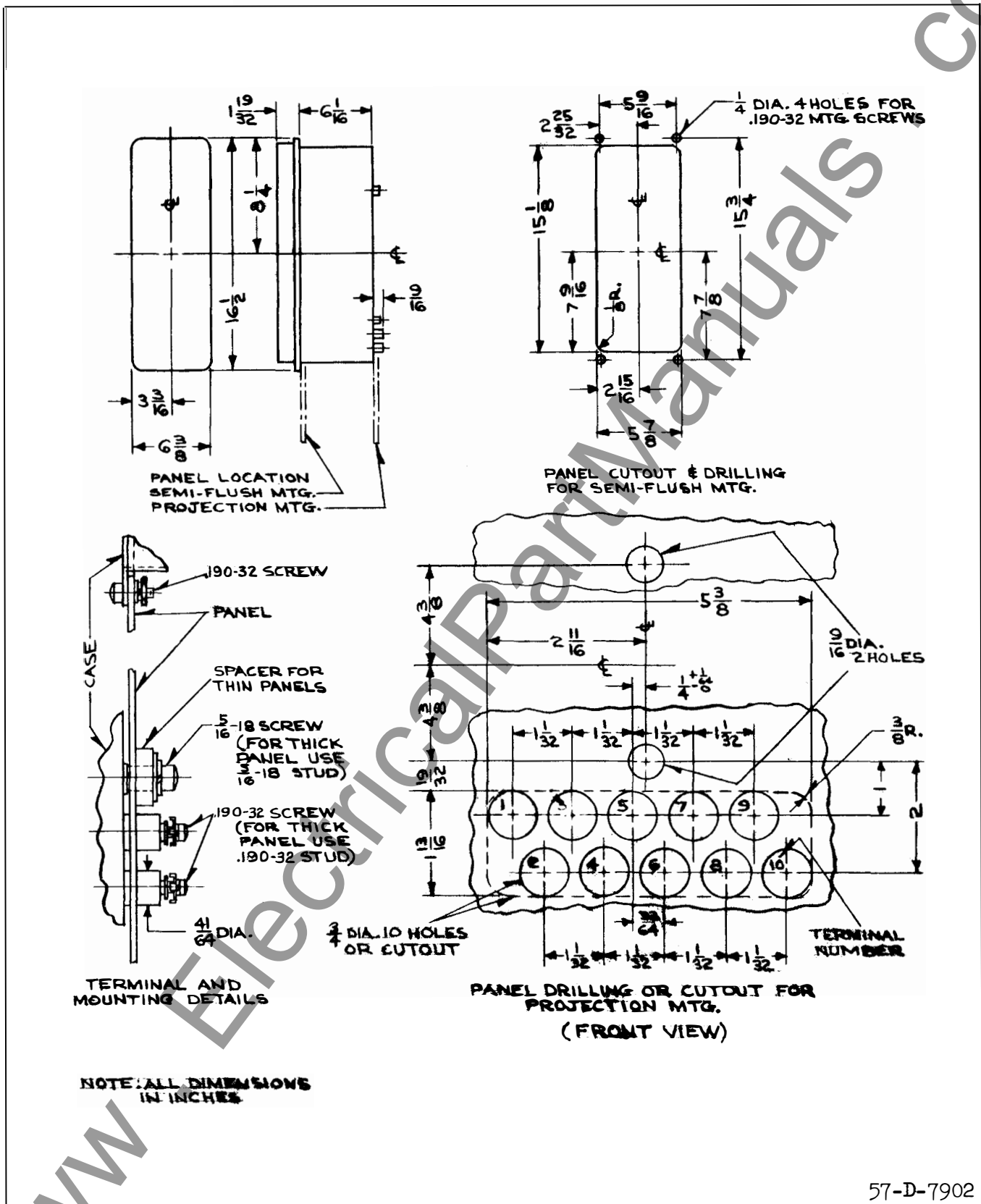

Fig. 6 Outline and Drilling Plan for the Type HRK and HRP Relays in the Type FT31 Case.

www.ElectricalPartManuals.com



WESTINGHOUSE ELECTRIC CORPORATION
METER DIVISION

NEWARK, N.J.

Printed in U.S.A.



INSTALLATION • OPERATION • MAINTENANCE INSTRUCTIONS

TYPES HRK AND HRP CARRIER DIRECTIONAL OVERCURRENT GROUND RELAYS (WITH TYPE HL-2 DIRECTIONAL ELEMENT)

CAUTION Before putting protective relays into service, remove all blocking which may have been inserted for the purpose of securing the parts during shipment, make sure that all moving parts operate freely, inspect the contacts to see that they are clean and close properly, and operate the relay to check the settings and electrical connections.

APPLICATION

These relays are used to provide directional ground fault protection in the carrier relaying scheme using plate keyed carrier sets. The type HRK relay is used where residual current from the power transformer banks is available for polarizing the directional element. The type HRP relay is used where this residual current is not available, and residual voltage must be used for polarizing the element.

CONSTRUCTION AND OPERATION

These relays consist of two beam-type overcurrent unit, a directional unit, and an indicating contactor switch. The trip circuit of the relay includes the directional contacts in series with the contacts of one overcurrent unit, the operation indicator, and the contactor switch. The other overcurrent unit is used to start carrier signal transmission. Operation of this relay in connection with the carrier scheme is fully described in I. L. 41-904.

Overcurrent Unit

The construction details of the two overcurrent unit are shown in Figure 1. The element consists of a pivoted beam with contact arm on one end and a restraining spring acting on the other. The beam is pulled down to make contact by a current coil, and resets through the action of the restraining spring.

The moving contact is a thin-walled silver

shell practically filled with tungsten powder. When this contact strikes the rigid stationary contact, the movement of the tungsten powder creates sufficient friction to absorb practically all of the energy of impact and thus the tendency of the contact to bounce is reduced to a minimum. The moving contact is loosely mounted on the beam and held in place by a leaf spring. The construction is such that the beam continues to move slightly after the contacts close deflecting the spring. This provides the required contact follow. Current is conducted into the moving contact by means of a flexible metal ribbon.

Directional Unit

The directional unit is made up of five basic parts: the die-cast aluminum frame, the electromagnet, the molded cover assembly, the moving element assembly, and the bridge and upper bearing pin assembly. The lower bearing pin and the magnetic core with its adjustment lever are mounted on the frame. The electromagnet has two series-connected polarizing coils mounted diametrically opposite one another, two series-connected current coils mounted diametrically opposite one another and two magnetic plugs accessible through the cover. The moving element consists of a spring and contact arm assembly and a double aluminum loop mounted on a shaft which has end jewels for the top and bottom bearings. This shaft rides between the bottom steel bearing pin mounted in the frame and a similar pin in the bridge that mounts on the two longer studs of the electromagnet. The stops for the moving element are mounted on the cover and are easily accessible for the adjustment of the contact travel. The spring adjuster seats on the molded cover and is attached to the contact through a spiral spring. The moving contact is made of two thin-walled silver shells practically filled with tungsten powder and mounted back to back

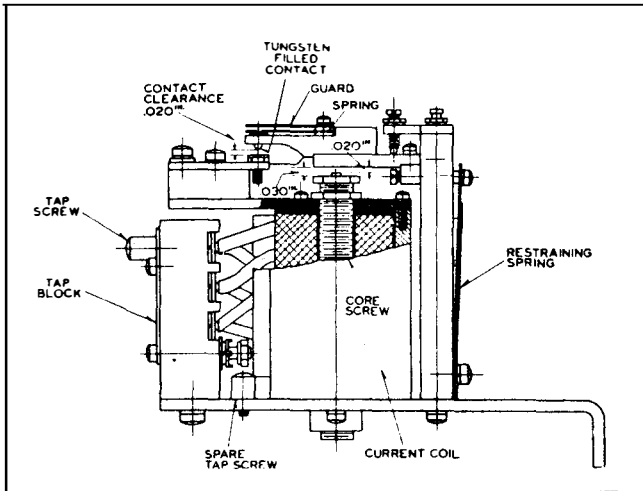

Fig. 1 Sectional View of the Overcurrent Units.

on a thin leaf spring. The stationary silver contacts are mounted on the molded cover. The electrical connection is made from the stationary contact to the moving contact, through the spiral and spring adjuster to the spring adjuster to the spring adjuster clamp. The flux in each pole face is lagged on the outside edges by copper loops. This produces a torque that counter-balances the centering torque, caused by the small power factor angle of the moving element.

The torque of the unit is produced by the interaction of the current and flux which develops forces on the two aluminum loops. The resulting torque is substantially free of vibrations, because the double-frequency torques that are produced on the two loops are equal and opposite in sign. The flux in each pole face is lagged on the outside edges. This produces a torque that counter-balances the centering torque, caused by the small power factor angle of the moving element.

Indicating Contactor Switch Unit (ICS)

The d-c indicating contactor switch is a small clapper type device. A magnetic armature, to which leaf-spring mounted contacts are attached, is attracted to the magnetic core upon energization of the switch. When the switch closes, the moving contacts bridge two stationary contacts, completing the trip circuit. Also during this operation two fingers on the armature deflect a spring located on the front of the switch, which allows the operation indicator target to drop. The target is reset from the

outside of the case by a push rod located at the bottom of the cover.

The front spring, in addition to holding the target, provides restraint for the armature and thus controls the pickup value of the switch.

CHARACTERISTICS AND SETTINGS

The overcurrent unit of the relays operates in one cycle or less on values of ground fault current above 200% of the tap setting. The taps available are:

- 0.5, 0.75, 1.0, 2.0, 4.0, 6.0.

The settings should be made by inserting the tap screw in the tap to give the required pick-up.

The carrier - start overcurrent unit at each line terminal is set on a lower tap than the tripping element at either end of the line. This arrangement insures proper blocking for remote external faults which may not pick up both overcurrent elements at each line terminal.

Select a tap for the tripping overcurrent unit (left-hand, front view) which will allow tripping the minimum internal ground fault. Set the carrier-start unit (right-hand, front view) on the next lower tap.

The HRK relay is designed for current polarization with maximum torque occurring when the operating current leads the polarizing current 30° to 35°. The minimum pick-up has been set by the spring tension to be approximately 1.0 ampere when current circuits are connected in series. Greater sensitivity may be obtained by decreasing the spring tension; however, this will also decrease the restoring force when the unit is de-energized.

The HRP relay is designed for potential polarization with an internal phase shifter so that the maximum torque occurs when the operating current lags the residual voltage by approximately 60 degrees. The minimum pick up has been set by the spring tension to be approximately 2.5 volts and 4 ampere at maximum torque.

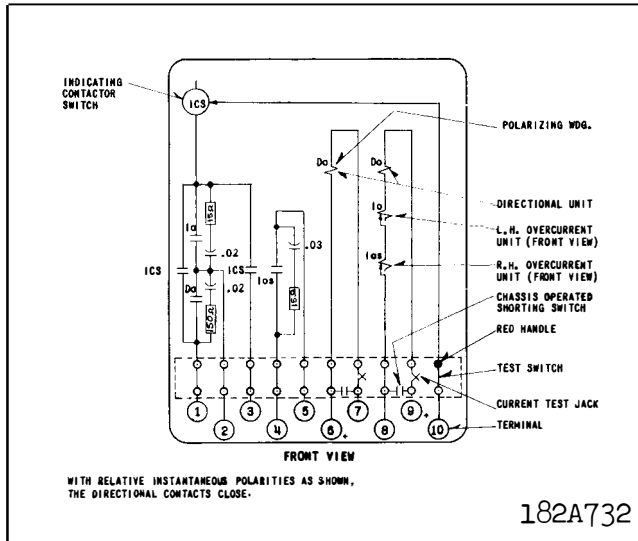

Fig. 2 Internal Schematic of the Type HRK Relay in the Type FT31 Case.

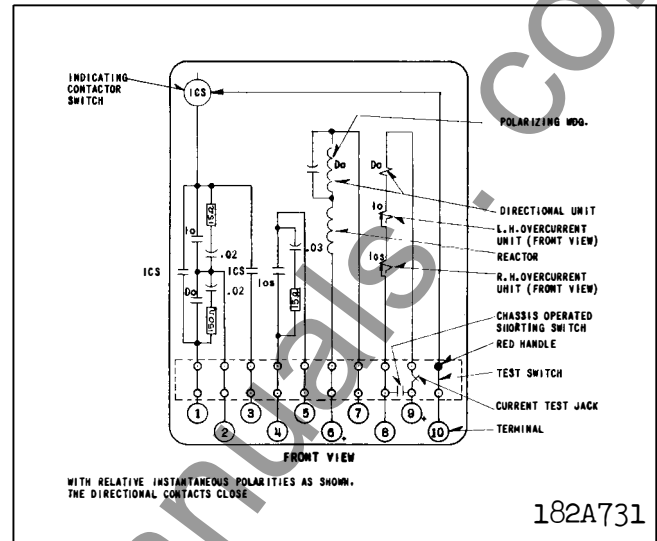

Fig. 3 Internal Schematic of the Type HRP Relay in the Type FT31 Case.

Trip Circuit

The main contacts will safely close 30 amperes at 250 volts d-c and the seal-in contacts of the indicating contactor switch will safely carry this current long enough to trip a circuit breaker.

The indicating contactor switch has two taps that provide a pickup setting of 0.2 or 2 amperes. To change taps requires connecting the lead located in front of the tap block to the desired setting by means of a screw connection. No other settings are required. Set in the 2.0 tap for all carrier relaying applications.

Trip Circuit Constant

Indicating Contactor Switch (ICS)

- 0.2 ampere tap 6.5 ohms d-c resistance
- 2.0 ampere tap 0.15 ohms d-c resistance

INSTALLATION

The relays should be mounted on switchboard panels or their equivalent in a location free from dirt, moisture, excessive vibration, and heat. Mount the relay vertically by means of the four mounting holes on the flange for semi-flush mounting or by means of the rear mounting stud or studs for projection mounting. Either a mounting stud or the mounting screws

may be utilized for grounding the relay. The electrical connections may be made directly to the terminals by means of screws for steel panel mounting or to the terminal studs furnished with the relay for thick panel mounting. The terminal studs may be easily removed or inserted by locking two nuts on the stud and then turning the proper nut with a wrench.

For detailed FT case information refer to I.L. 41-076.

The a-c external schematics of both the type HRK and HRP relays are shown in Figures 4 and 5. The carrier relaying d-c schematic (supplied with all carrier orders) should be consulted for the details of the external d-c connections of these relays.

ADJUSTMENTS

The proper adjustments to insure correct operation of this relay have been made at the factory and should not be disturbed after receipt by the customer. If the adjustments have been changed, the relay taken apart for repairs, or if it is desired to check the adjustments at regular maintenance periods, the instructions below should be followed.

All contacts should be cleaned periodically. A contact burnisher S#182A836H01 is recommended for this purpose. The use of abrasive

above. Energize the unit in the opening direction by passing 60 amperes through the current circuits in series. The contact should not bounce closed when the element is suddenly de-energized. Slight readjustment of the left-hand stop may be necessary to insure that this does not happen. The magnetic plugs which are accessible through the molded cover are used to adjust for zero torque with current only in the operating coils. Raising the right-hand plug will produce torque to the right when considering the front moving contact. Adjust the plugs so that the contacts remain open with 30, 50 and 80 amperes momentarily applied.

Type HRP relays only - The moving element stops should be adjusted so that the moving contact just touches the stationary contact when energized in the closing direction with 120 volts and 5.0 amperes at 60 degrees lag. The right-hand stationary contact should then be turned 1/6th of a turn to obtain .005 inch contact follow. The rear and left stationary contact stops should be adjusted to barely miss the moving contact when energized as above. Energize the unit in the opening direction with 120 volts and 60 amperes at 240 degrees lag. The contact should not bounce closed when the unit is suddenly de-energized. Slight readjustment of the left-hand stop may be necessary to insure that this does not happen.

The lever at the bottom of the unit should be adjusted so that the unit will operate with 30 amperes and 0.1 to 0.4 volt at the maximum torque angle. After this adjustment, short the voltage coils and check to insure that the contacts do not close on 60 amperes momentarily applied. Raising the right-hand plug under these conditions will produce torque to the right when considering the front moving contact. The unit can be adjusted to just remain open under these conditions or adjusted to operate with 60 amperes and 0.1 to 0.4 volts at the maximum torque angle.

Indicating Contactor Switch Unit (ICS)

Close the main relay contacts and pass sufficient d-c current through the trip circuit to close the contacts of the ICS. This value of current should not be greater than the particular ICS tap setting being used. The indicator target should drop freely.

RENEWAL PARTS

Repair work can be done most satisfactorily at the factory. However, interchangeable parts can be furnished to the customers who are equipped for doing repair work. When ordering parts, always give the complete name-plate data.

ENERGY REQUIREMENTS

The typical 60 cycle burdens of the various circuits of these relays are as follows:

HRP Relay Only

Directional element and overcurrent unit in series:

0.5 amp. tap at 0.5 amps.	.6 v. a.	41° lag
6.0 amp. tap at 6.0 amps.	3.8 v. a.	36° lag

Directional element polarizing circuit:

At 120 volts.	6.9 v. a.	42° lag
---------------	-----------	---------

HRK Relay Only

Directional unit and overcurrent unit in series:

0.5 amp. tap at 0.5 amps.	.6 v. a.	41° lag
6.0 amp. tap at 6.0 amps.	6.7 v. a.	40° lag

Directional unit polarizing circuit:

At 5.0 amperes	4.8 v. a.	10° lag
----------------	-----------	---------

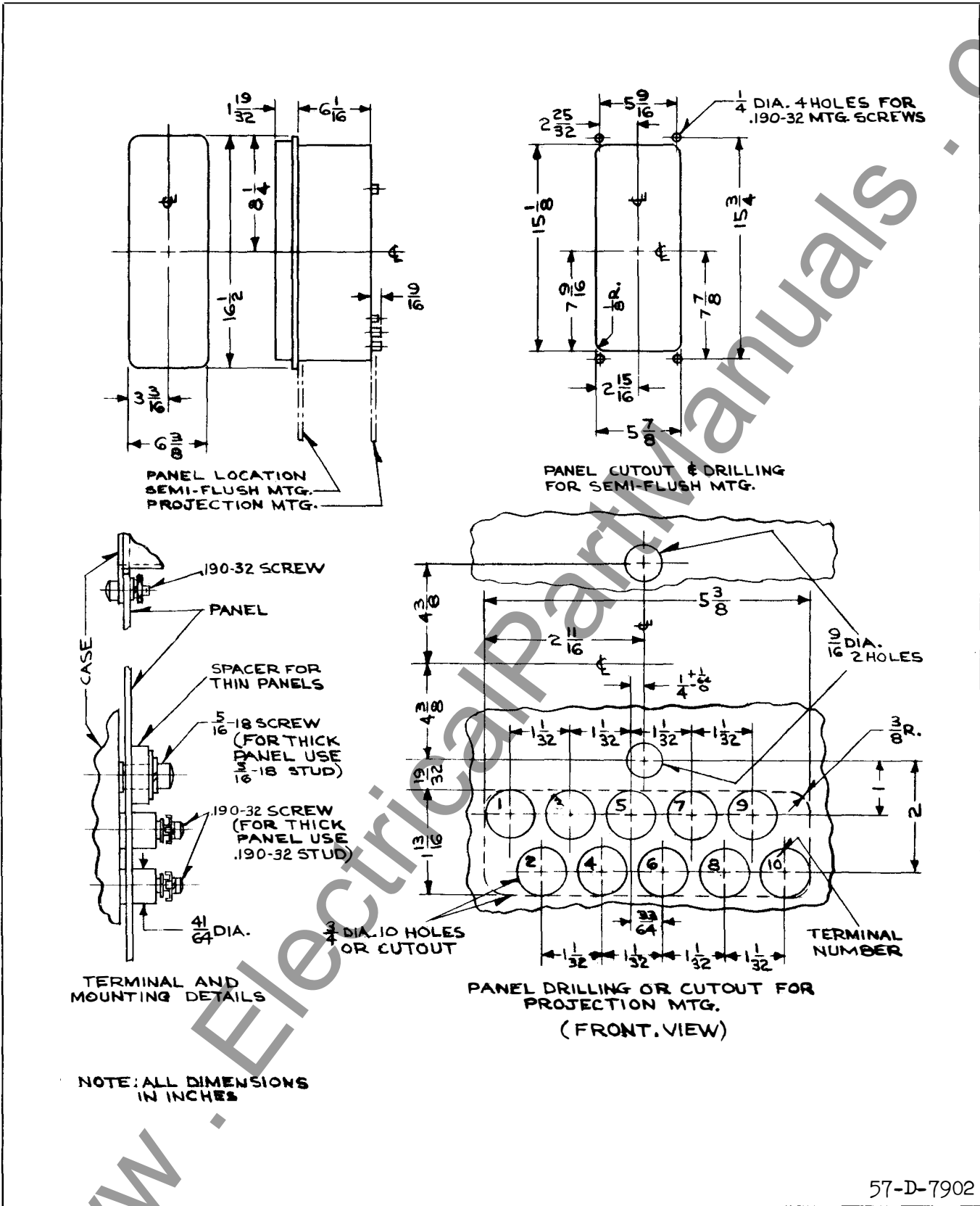

Fig. 6 Outline and Drilling Plan for the Type HRK and HRP Relays in the Type FT31 Case.

www.ElectricalPartManuals.com



WESTINGHOUSE ELECTRIC CORPORATION
METER DIVISION . **NEWARK, N.J.**

Printed in U.S.A.

**INSTALLATION • OPERATION • MAINTENANCE
I N S T R U C T I O N S****TYPES HRK AND HRP CARRIER DIRECTIONAL
OVERCURRENT GROUND RELAYS
(WITH TYPE HL-2 DIRECTIONAL ELEMENT)**

CAUTION Before putting protective relays into service, remove all blocking which may have been inserted for the purpose of securing the parts during shipment, make sure that all moving parts operate freely, inspect the contacts to see that they are clean and close properly, and operate the relay to check the settings and electrical connections.

APPLICATION

These relays are used to provide directional ground fault protection in the carrier relaying scheme using plate keyed carrier sets. The type HRK relay is used where residual current from the power transformer banks is available for polarizing the directional element. The type HRP relay is used where this residual current is not available, and residual voltage must be used for polarizing the element.

CONSTRUCTION AND OPERATION

These relays consist of two beam-type overcurrent unit, a directional unit, and an indicating contactor switch. The trip circuit of the relay includes the directional contacts in series with the contacts of one overcurrent unit, the operation indicator, and the contactor switch. The other overcurrent unit is used to start carrier signal transmission. Operation of this relay in connection with the carrier scheme is fully described in I. L. 41-904.

Overcurrent Unit

The construction details of the two overcurrent unit are shown in Figure 1. The element consists of a pivoted beam with contact arm on one end and a restraining spring acting on the other. The beam is pulled down to make contact by a current coil, and resets through the action of the restraining spring.

The moving contact is a thin-walled silver

shell practically filled with tungsten powder. When this contact strikes the rigid stationary contact, the movement of the tungsten powder creates sufficient friction to absorb practically all of the energy of impact and thus the tendency of the contact to bounce is reduced to a minimum. The moving contact is loosely mounted on the beam and held in place by a leaf spring. The construction is such that the beam continues to move slightly after the contacts close deflecting the spring. This provides the required contact follow. Current is conducted into the moving contact by means of a flexible metal ribbon.

Directional Unit

The directional unit is made up of five basic parts: the die-cast aluminum frame, the electromagnet, the molded cover assembly, the moving element assembly, and the bridge and upper bearing pin assembly. The lower bearing pin and the magnetic core with its adjustment lever are mounted on the frame. The electromagnet has two series-connected polarizing coils mounted diametrically opposite one another, two series-connected current coils mounted diametrically opposite one another and two magnetic plugs accessible through the cover. The moving element consists of a spring and contact arm assembly and a double aluminum loop mounted on a shaft which has end jewels for the top and bottom bearings. This shaft rides between the bottom steel bearing pin mounted in the frame and a similar pin in the bridge that mounts on the two longer studs of the electromagnet. The stops for the moving element are mounted on the cover and are easily accessible for the adjustment of the contact travel. The spring adjuster seats on the molded cover and is attached to the contact through a spiral spring. The moving contact is made of two thin-walled silver shells practically filled with tungsten powder and mounted back to back

SUPERSEDES I.L. 41-916.1B

*Denotes change from superseded issue.

EFFECTIVE APRIL 1961

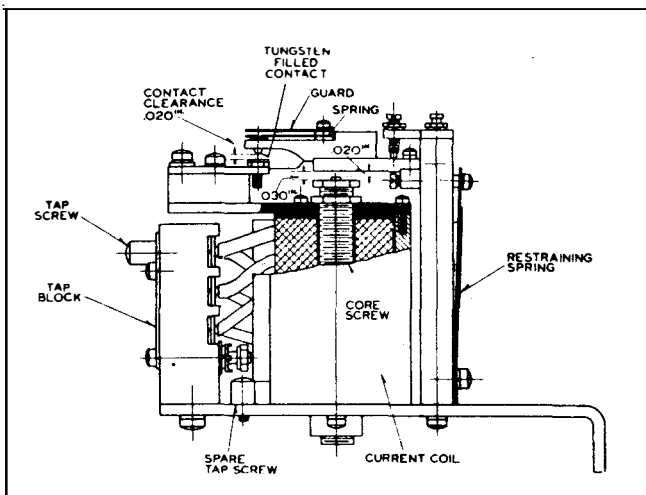

Fig. 1 Sectional View of the Overcurrent Units.

on a thin leaf spring. The stationary silver contacts are mounted on the molded cover. The electrical connection is made from the stationary contact to the moving contact, through the spiral and spring adjuster to the spring adjuster to the spring adjuster clamp. The flux in each pole face is lagged on the outside edges by copper loops. This produces a torque that counter-balances the centering torque, caused by the small power factor angle of the moving element.

The torque of the unit is produced by the interaction of the current and flux which develops forces on the two aluminum loops. The resulting torque is substantially free of vibrations, because the double-frequency torques that are produced on the two loops are equal and opposite in sign. The flux in each pole face is lagged on the outside edges. This produces a torque that counter-balances the centering torque, caused by the small power factor angle of the moving element.

Indicating Contactor Switch Unit (ICS)

The d-c indicating contactor switch is a small clapper type device. A magnetic armature, to which leaf-spring mounted contacts are attached, is attracted to the magnetic core upon energization of the switch. When the switch closes, the moving contacts bridge two stationary contacts, completing the trip circuit. Also during this operation two fingers on the armature deflect a spring located on the front of the switch, which allows the operation indicator target to drop. The target is reset from the

outside of the case by a push rod located at the bottom of the cover.

The front spring, in addition to holding the target, provides restraint for the armature and thus controls the pickup value of the switch.

CHARACTERISTICS AND SETTINGS

The overcurrent unit of the relays operates in one cycle or less on values of ground fault current above 200% of the tap setting. The taps available are:

- 0.5, 0.75, 1.0, 2.0, 4.0, 6.0.

The settings should be made by inserting the tap screw in the tap to give the required pick-up.

The carrier - start overcurrent unit at each line terminal is set on a lower tap than the *tripping element at the opposite end of the line. This arrangement insures proper blocking for remote external faults which may not pick up both overcurrent elements at each line terminal.

Select a tap for the tripping overcurrent unit (left-hand, front view) which will allow tripping the minimum internal ground fault. Set the carrier-start unit (right-hand, front view) on the next lower tap.

The HRK relay is designed for current polarization with maximum torque occurring when the operating current leads the polarizing current 30° to 35°. The minimum pick-up has been set by the spring tension to be approximately 1.0 ampere when current circuits are connected in series. Greater sensitivity may be obtained by decreasing the spring tension; however, this will also decrease the restoring force when the unit is de-energized.

The HRP relay is designed for potential polarization with an internal phase shifter so that the maximum torque occurs when the operating current lags the residual voltage by approximately 60 degrees. The minimum pick up has been set by the spring tension to be approximately 2.5 volts and 4 ampere at maximum torque.

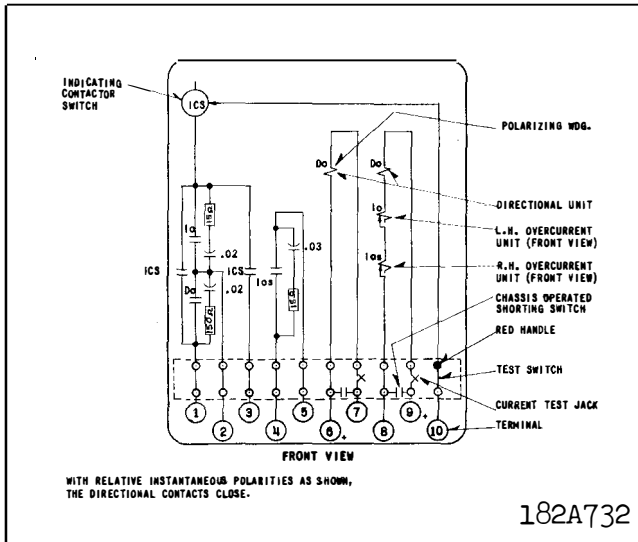

Fig. 2 Internal Schematic of the Type HRK Relay in the Type FT31 Case.

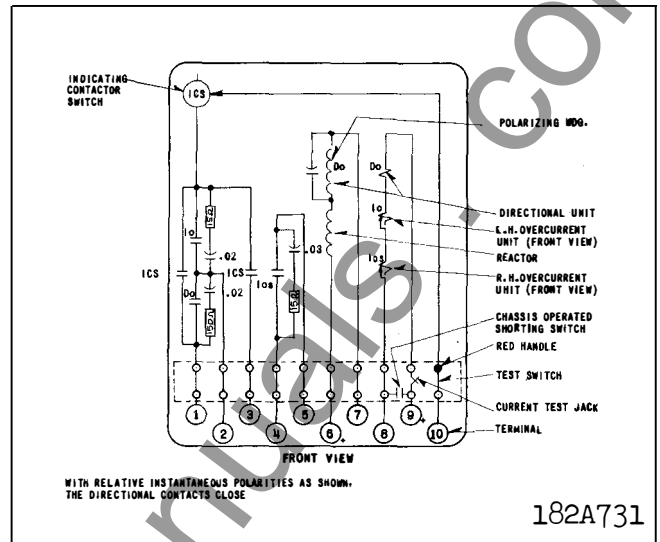

Fig. 3 Internal Schematic of the Type HRP Relay in the Type FT31 Case.

Trip Circuit

The main contacts will safely close 30 amperes at 250 volts d-c and the seal-in contacts of the indicating contactor switch will safely carry this current long enough to trip a circuit breaker.

The indicating contactor switch has two taps that provide a pickup setting of 0.2 or 2 amperes. To change taps requires connecting the lead located in front of the tap block to the desired setting by means of a screw connection. No other settings are required. Set in the 2.0 tap for all carrier relaying applications.

Trip Circuit Constant

Indicating Contactor Switch (ICS)

- 0.2 ampere tap 6.5 ohms d-c resistance
- 2.0 ampere tap 0.15 ohms d-c resistance

INSTALLATION

The relays should be mounted on switchboard panels or their equivalent in a location free from dirt, moisture, excessive vibration, and heat. Mount the relay vertically by means of the four mounting holes on the flange for semi-flush mounting or by means of the rear mounting stud or studs for projection mounting. Either a mounting stud or the mounting screws

may be utilized for grounding the relay. The electrical connections may be made directly to the terminals by means of screws for steel panel mounting or to the terminal studs furnished with the relay for thick panel mounting. The terminal studs may be easily removed or inserted by locking two nuts on the stud and then turning the proper nut with a wrench.

For detailed FT case information refer to I.L. 41-076.

The a-c external schematics of both the type HRK and HRP relays are shown in Figures 4 and 5. The carrier relaying d-c schematic (supplied with all carrier orders) should be consulted for the details of the external d-c connections of these relays.

ADJUSTMENTS

The proper adjustments to insure correct operation of this relay have been made at the factory and should not be disturbed after receipt by the customer. If the adjustments have been changed, the relay taken apart for repairs, or if it is desired to check the adjustments at regular maintenance periods, the instructions below should be followed.

All contacts should be cleaned periodically. A contact burnisher S#182A836H01 is recommended for this purpose. The use of abrasive

TYPES HRK AND HRP RELAYS

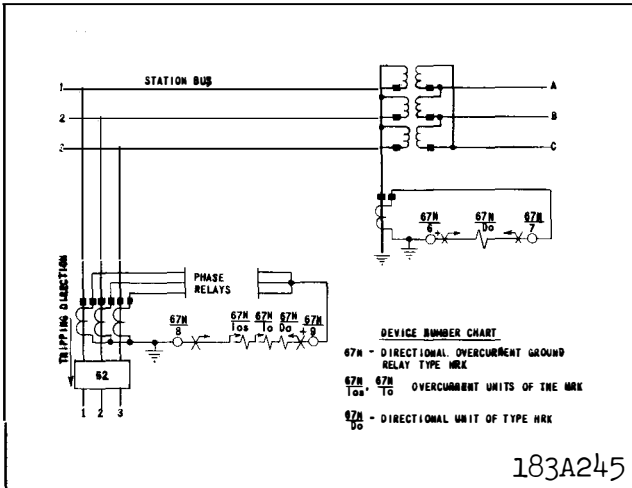

Fig. 4 External A-C Schematic of the Type HRK Relay.

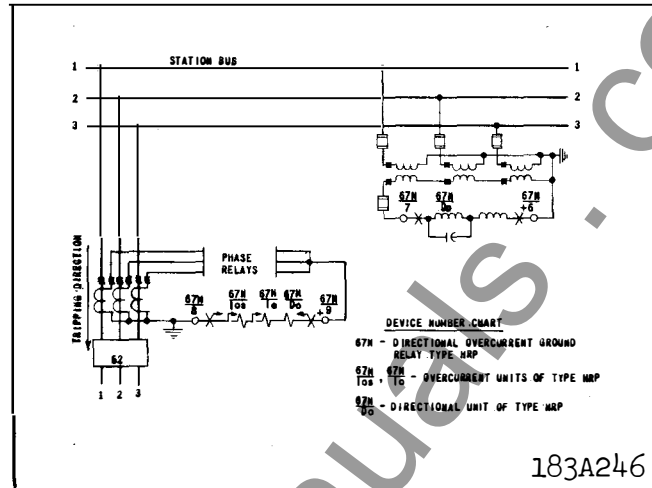

Fig. 5 External A-C Schematic of the Type HRP Relay.

material for cleaning contacts is not recommended, because of the danger of embedding small particles in the face of the soft silver and thus impairing the contact.

Overcurrent Units

Refer to Figure 1. Adjust the stop screw until the beam is in a horizontal position when resting against it. Adjust the magnetic gap to .020 inch. This is the gap between the beam and the stop pin. Adjust the stationary contact for an .020 inch gap when the beam is in the reset position. When the beam is in the operated position, there should be an .015 inch deflection of the moving contact. See that the spring which is carried by the moving element lies flat on the micarta arm with no initial tension in either direction. Also, make sure that the flexible pigtail is at least 3/32 inch away from the end of the stationary contact.

Pass 0.5 ampere thru the unit with the tap screw in the 0.5 tap and adjust the beam spring tension until the beam just trips. This spring tension should hold the beam in the reset position, and when the beam is tripped on 0.5 ampere, the beam should deflect the moving contact spring and rest on the front stop pin. The tripping point of the other taps should be within $\pm 5\%$ of the tap values.

Directional Unit

The upper bearing screw should be screwed down until there is only three to four thou-

sandths of an inch clearance between it and the shaft, and then securely locked in position with the lock nut. This adjustment can be made best by carefully screwing down the top bearing screw until the double loop fails to turn freely and then backing up 1/8" of a turn. Great care must be taken in making this adjustment to prevent damage to the bearings.

The travel of the moving contact is limited by the stationary contacts mounted on the molded cover. The contact gap should be adjusted as follows: With the moving contact centered between the studs, close the contact gaps by advancing the two front stationary contacts. Then back off the right-hand stationary contact .035 inch and lock both contacts in place. The front contact spring should be positioned in the center of the .020 inch slot of the aluminum guard by means of the small adjusting screw located on the nut plate that holds the spring on the moving element. The complete moving element is limited in travel by two stop screws located on the molded cover assembly.

Type HRK relays only - The moving element stops should be adjusted so that the moving contact just touches the stationary contact when energized in the closing direction with 5.0 amperes in phase in the current circuits. The right-hand stationary contact should be turned 1/6th of a turn to obtain .005 inch contact follow. Adjust the back left-hand stationary contact to just miss the moving con-

tact. Reverse the connections to one circuit and adjust the other stop so that the moving contact barely misses the left front stationary contact. Adjust the rear right hand stationary contact to just miss the moving contact. Adjust the spring tension so that the contacts close with 1 ampere applied (currents in phase). Energize the unit in the opening direction by passing 50 amperes through the current circuits in series. The contact should not bounce closed when the element is suddenly deenergized. Slight readjustment of the left-hand stop may be necessary to insure that this does not happen. The magnetic plugs which are accessible through the molded cover are used to adjust for zero torque with current only in the operating coils. Raising the right-hand plug will produce torque to the right when considering the front moving contact. Adjust the plugs so that the contacts remain open with 30, 50 and 80 amperes momentarily applied.

- * Type HRP relays only - The right-hand moving element stop should be adjusted so that the moving contact just touches the stationary contact when energized in the closing direction with 120 volts and 5.0 amperes at 60 degrees lag. The right-hand stationary contact should then be turned 1/6th of a turn to obtain .005 inch contact follow. Adjust the rear left-hand stationary contact to just miss the moving contact. Reverse the connections to one circuit and adjust the left hand stop so that the moving contact just barely misses the left-hand stationary contact. Also adjust the rear right-hand stationary contact to just miss the moving contact. Adjust the spring tension so that the contact just closes with 2.5 volts and 4 amperes at 60 degrees lag. Energize the unit in the opening direction with 120 volts and 60 amperes at 240 degrees lag. The contact should not bounce closed when the unit is suddenly de-energized. Slight readjustment of the left-hand stop may be necessary to insure that this does not happen.

The Lever at the bottom of the unit should be adjusted so that the unit will operate with * 25 amperes and 0.1 to 0.4 volt at the maximum torque angle. After this adjustment, short the voltage coils and check to insure that the contacts do not close on 60 amperes momentarily applied. Raising the right-hand plug under

these conditions will produce torque to the right when considering the front moving contact. The unit can be adjusted to just remain open under these conditions or adjusted to operate with 60 amperes and 0.1 to 0.4 volts at the maximum torque angle.

Indicating Contactor Switch Unit (ICS)

Close the main relay contacts and pass sufficient d-c current through the trip circuit to close the contacts of the ICS. This value of current should not be greater than the particular ICS tap setting being used. The indicator target should drop freely.

RENEWAL PARTS

Repair work can be done most satisfactorily at the factory. However, interchangeable parts can be furnished to the customers who are equipped for doing repair work. When ordering parts, always give the complete name-plate data.

ENERGY REQUIREMENTS

The typical 60 cycle burdens of the various circuits of these relays are as follows:

HRP Relay Only

Directional element and overcurrent unit in series:

0.5 amp. tap at 0.5 amps.	.6 v. a.	41° lag
6.0 amp. tap at 6.0 amps.	3.8 v. a.	36° lag

Directional element polarizing circuit:

At 120 volts.	6.9 v. a.	42° lag
---------------	-----------	---------

HRK Relay Only

Directional unit and overcurrent unit in series:

0.5 amp. tap at 0.5 amps.	.6 v. a.	41° lag
6.0 amp. tap at 6.0 amps.	6.7 v. a.	40° lag

Directional unit polarizing circuit:

At 5.0 amperes	4.8 v. a.	10° lag
----------------	-----------	---------

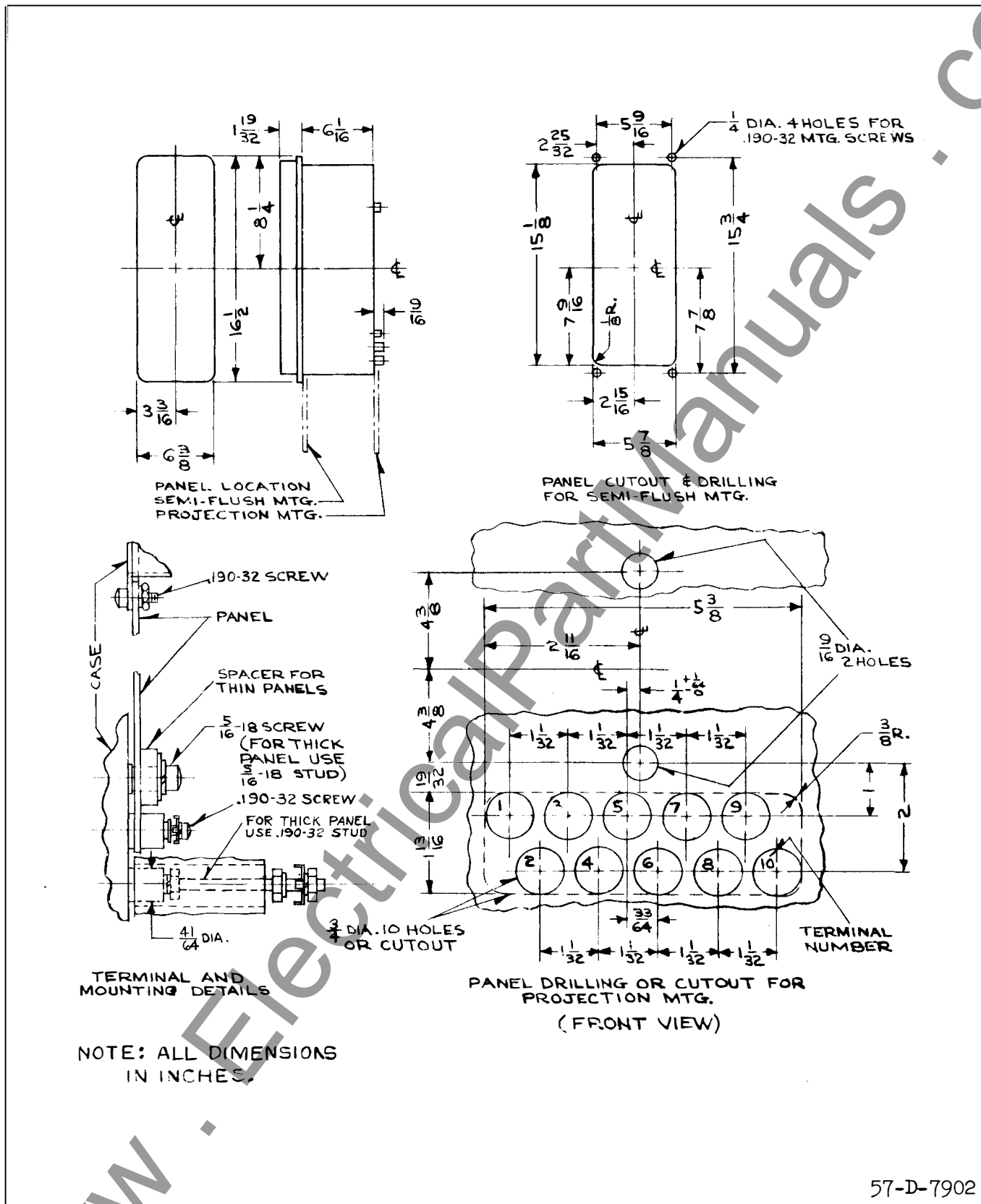

* Fig. 6 Outline and Drilling Plan for the Type HRK and HRP Relays in the Type FT31 Case.

www.ElectricalPartManuals.com



WESTINGHOUSE ELECTRIC CORPORATION
RELAY DEPARTMENT

NEWARK, N. J.

Printed in U. S. A.