

INSTALLATION • OPERATION • MAINTENANCE INSTRUCTIONS

TYPE PM LINE OF RELAYS FOR PILOT-WIRE MONITORING AND TRANSFERRED TRIPPING

CAUTION Before putting protective relays into service, remove all blocking which may have been inserted for the purpose of securing parts during shipment, make sure that all moving parts operate freely, inspect the contacts to see that they are clean and close properly, and operate the relay to check the settings and electrical connections.

APPLICATION

Type PM Monitoring Relays provide continuous monitoring of a pilot-wire circuit to detect open circuits, short circuits, grounds, and wire reversal. In addition, transferred tripping can be effected where the PM-3, PM-13, PMG-13 or PM-23 relays are used. Table I illustrates the functions available with each relay. A 10 mfd. capacitor is supplied with each PM relay. This capacitor provides an a c path between the two halves of the insulating transformer secondary windings as shown in Figs. 25 through 31.

Each circuit requires the following:

At one end to introduce monitoring current

One of the following:

For ac supply

PMA
PMA-1
PM-13 or PMG-13 (ac)

For dc supply

PMD
PMD-1
PM-13 or PMG-13 (dc)

At the other end to receive monitoring current (two-terminal line)

One PM-23 or PM-2 or PM-4

At the other ends to receive monitoring current (three-terminal line)

One PM-23 or one PM-4 or one PM-2 for each remote terminal.

CONSTRUCTION

PM relays consist of the following:

PMA

1-Polar Alarm Unit (1)

PMA-1

1-Polar Alarm Unit

1-Polar Ground Unit (5)
1-Tapped Transformer
1-Full-Wave Rectifier
3-4 mfd. Capacitors
1-Set of Potential
Dividing Resistors

PMD

1-Polar Alarm Unit (1)
1-Polar Ground Unit (5)
2-4 mfd. Capacitors
1-Set of Potential
Divider Resistors

PMG-13

1-Polar Alarm Unit (1)
1-Polar Ground Unit (5)
1-Polar Trip Unit (3)
1-Indicating Contactor
Switch
1-Set of Potential
Divider Resistors
1-Tapped Transformer
(A.C. Relay only)
1-Full-Wave Rectifier
(A.C. Relay only)
1-Blocking Rectifier
2-Remote Trip Resistors
3-4 mfd. Capacitors
(A-C Relay)
2-4 mfd. Capacitors
(D-C Relay)

1-Tapped Transformer
1-Full-Wave Rectifier
1-4 mfd. Capacitor
1-Set of Potential
Dividing Resistors

PMD-1

1-Polar Alarm Unit
1-Set of Potential
Divider Resistors

PM-13

1-Polar Alarm Unit (1)
1-Polar Trip Unit (3)
1-Indicating Contactors
Switch
1-Set of Potential
Divider Resistors
1-Tapped Transformer
(A.C. Relay only)
1-Full-Wave Rectifier
(A.C. Relay only)
1-Blocking Rectifier
2-Remote Trip Resistor
1-4 mfd. Capacitor

All possible contingencies which may arise during installation, operation, or maintenance, and all details and variations of this equipment do not purport to be covered by these instructions. If further information is desired by purchaser regarding his particular installation, operation or maintenance of his equipment, the local Westinghouse Electric Corporation representative should be contacted.

TYPE PM MONITORING RELAYS

PM-23

- 1-Polar Alarm Unit (2)
- 1-Polar Trip Unit (3)
- 1-Indicating Contactor Switch (ICS)
- 1-Milliammeter, 5.0 ma.
- 1-Set of Adjustable and Fixed Resistors
- 2-Blocking Rectifiers

PM-2

- 1-Polar Alarm Unit (2)
- 1-Milliammeter, 5.0 ma.
- 1-Set of Adjustable Resistors
- 1-Blocking Rectifier

PM-3

- 1-Polar Trip Unit (3)
- 1-Resistor
- 1-Blocking Rectifier
- 1-Indicating Contactor Switch (ICS)

PM-4

- 1-Blocking Rectifier
- 1-Set of Adjustable & Fixed Resistors

PM-5

- 1-Polar Ground Unit (5)
- 2-4 mfd. Capacitors
- 1-Fixed Resistor

TABLE I

FUNCTION	PMA & PMD	PMA-1 & PMD-1	PM-13	PMG-13	PM-23	PM-2	PM-3	PM-4	PM-5
Monitoring Current Source	X	X	X	X					
Receives Monitoring Current					X	X		X	
Trouble Alarm	X	X	X	X	X	X			X
Transmits Trip Signal	X †	X †	X	X	X †	X †	X †	X †	
Receives Trip Signal			X	X	X		X		
Sensitive Ground Detection	X			X					X
Measures Monitoring Current					X	X			

† With External Resistors

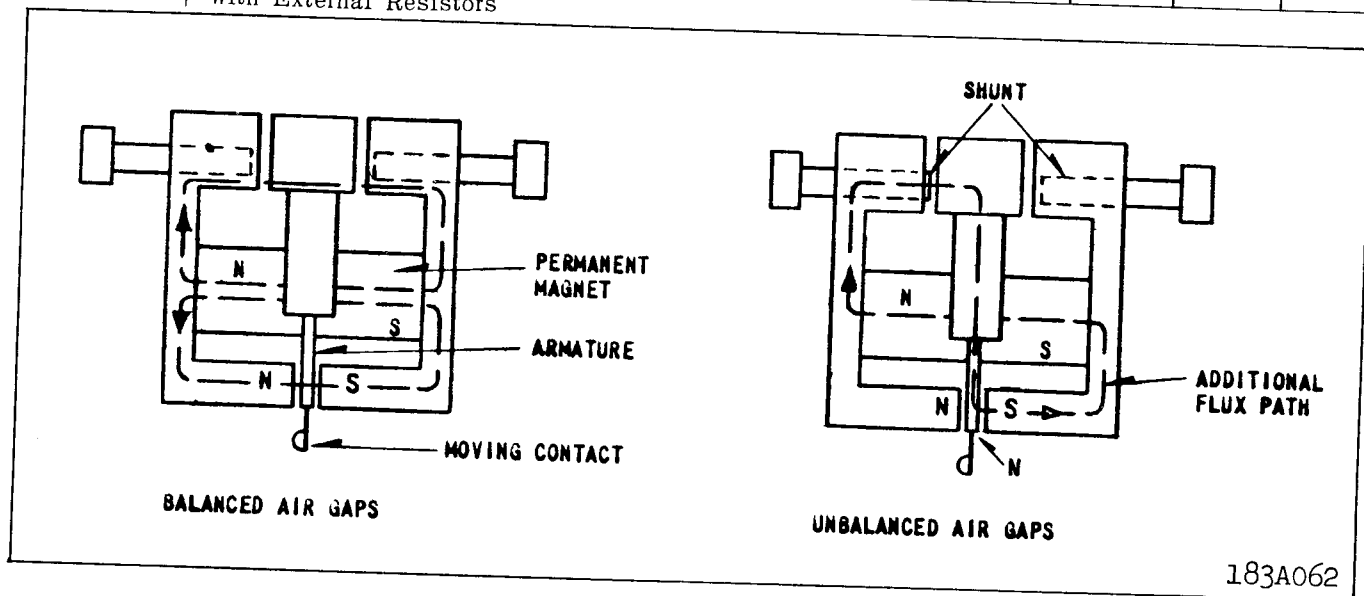

Fig. 1. Polar Unit Permanent Magnet Flux Paths.

183A062

Polar Unit

The polar unit consists of a rectangular shaped magnetic frame, an electromagnet, a permanent magnet, and an armature. The poles of the crescent shaped permanent magnet bridge the magnet frame. The magnetic frame consists of three pieces joined in the rear with two brass rods and silver solder. These non-magnetic joints represent air gaps, which are bridged by two adjustable magnetic shunts. The winding or windings are wound around a magnetic core. The armature is fastened to this core and is free to move in the front air gap. The moving contact is connected to the free end of a leaf spring, which, in turn, is fastened to the armature.

Indicating Contactor Switch

The d-c indicating contactor switch is a small clapper type device. A magnetic armature, to which leaf-spring mounted contacts are attached, is attracted to the magnetic core upon energization of the switch. When the switch closes, the moving contacts bridge two stationary contacts, completing the trip circuit. Also during this operation two fingers on the armature deflect a spring located on the front of the switch, which allows the operation indicator target to drop. The target is reset from the outside of the case by a push rod located at the bottom of the cover.

The front spring, in addition to holding the target, provides restraint for the armature and thus controls the pickup value of the switch.

PMD & PMG13 with Tel. Relay: In the relays type PMD and PMG13 where they are energized with DC power supply, the ground polar unit (#5) could momentarily close its contact (for about 10 m.s.) if either positive or negative supply is grounded. To eliminate this momentary operation, a telephone relay with a nominal operating time of 25 m.s. was connected in series with contact of the "5" unit, and the contact of the telephone relay is used as an overall contact output of the "5" unit. This type of relay should be used where the DC power supply is subjected to short to the ground.

OPERATION

Pilot Wire Monitoring

Monitoring current is introduced into the pilot wire as shown in the external schematics, figures 25 to 31, by the monitoring current source. External schematics showing other combinations are available on request. A nominal 20 volts is impressed across the 10 mfd. capacitor at the left-hand line terminal in Figures 25 to 31. This voltage produces a current circulating through one winding of the HCB insulating transformer, one pilot wire, the PM-23, PM-2, or PM-4,

and back through the other pilot wire and the other winding of HCB insulating transformer.

Adjustment of the resistors of the PM-23, PM-2 or PM-4 relay at the other end of the pilot wire provides a normal one-milliampere d-c circulating current. In the case of three-terminal lines, the monitoring source relay output current is 2 ma. in order to provide each receiving end relay with 1 ma. The alarm unit of the monitoring current source relay is adjusted to float between the high and low current contacts with normal monitoring current. The PM-23, receiving-end alarm relay, is adjusted to float between the low-current alarm contact and a contact stop with 1 ma. flowing.

Short Circuits

A complete or partial short circuit on the pilot wires increases the current in the current-source relay, causing the high-current alarm contacts to close. The resulting current decrease in the PM-23 relay closes the alarm contact. Short circuits of 5000 ohms or less will be detected.

Open Circuits

Current decreases to zero in all relays. Low-current alarm contact of the current source relay closes. Alarm contact of PM-23 relay closes.

Reversed Wires

On applications using the PM-23 relay, current increases in the sending end relay to close the high-current alarm contacts. Current drops to zero in the PM-23 relay monitoring coil to close the low-current alarm contacts.

If the pilot wire should be opened, the low-current contacts of the (2) unit will close. If the pilot wire is then reconnected with reversed connections, the (2) unit low-current contacts will remain closed. The capacitor at the sending end discharges through the pilot wire and the trip unit (3) circuit when the pilot wire is connected reversed. This would momentarily operate the trip unit (3) contact which would cause an incorrect trip; however, this is prevented by the (2) unit low-current contacts which connect a 2.25K resistor across the trip unit (3) coil. The 2.25K resistor remains connected across the trip-unit (3) coil until the pilot wire is connected properly.

The current decreases in both sending and receiving end relays when the PM-2, or PM-4 relays are used. Low current alarm contacts close.

Grounds

The voltage-divider circuit of the PMA, PMD, and PMG-13 source relays has its midpoint grounded through a current-limiting resistor. Thus, a pilot-wire ground will cause an increase in current in one coil

TYPE PM MONITORING RELAYS

circuit, and a decrease in the other one. This unbalance in the current flowing through the two windings (5) of the ground alarm relay unit will cause it to close one of its contacts (depending on which pilot wire is grounded) to give an alarm. Grounds of 10,000 ohms or less will be detected.

For adding the sensitive ground detection where PMA-1, PMD-1, or PM-13 relays have been installed, the PM-5 relay can be added to the circuitry, as shown in figure 30. This relay also has a 10,000-ohm ground sensitivity.

Transferred Tripping

Breakers located at the PMG-13 or PM-13 and PM-3 or PM-23 stations can be tripped by the application of a d-c voltage to the pilot wires at remote locations, as shown in figures 25 to 31. Transferred tripping can be effected from any location by applying 48 volts d-c (through dropping resistors when required) to the pilot wire with polarity opposite to that of the monitoring voltage. When tripping the PM-23, the current is increased above 2.0 ma, in reverse direction, to close the trip contact. When tripping the PMG-13 or PM-13, the reversed d.c. voltage operates the trip unit (3).

See Tables II and III for tripping resistor values. Nominal tripping currents is 5ma. at all rated voltages.

Polar Unit

Polar unit flux paths are shown in figure 1. With balanced air gaps, permanent magnet flux flows in two paths, one through the front, and one through the rear gaps. This flux produces north and south poles, as shown. By turning the left shunt in, some of the flux is forced through the armature, making it a north pole. Thus, reducing the left hand rear gap will produce a force tending to pull the armature to the right. Similarly, reducing the right hand gap will make the armature a south pole and produce a force tending to pull the armature to the left.

The alarm unit contacts of the sending and receiving end relays are biased to move to the left when the relay is deenergized. The PMG-13 or PM-13 and PM-23 trip unit contact is biased to move to the left when the relay is deenergized. The PM-5 is adjusted so that the moving contact floats when the relay is deenergized.

CHARACTERISTICS

Nominal Calibration Values

Nominal current values to close contacts are listed in Tables IV and V

Voltage Ratings

Supply voltage ratings of the monitoring source relays to obtain continuous monitoring current are as follows:

DC - 48, 125, and 250 volts

AC - 120 volts, 60 hertz (Primary taps 100, 110, 120 & 130)

Voltage impressed on the pilot wire is a nominal 20 volts for monitoring, and 48 volts for tripping.

Supply voltage ratings to obtain remote tripping are: 48, 125, and 250 volts d-c.

Coil Resistance (each winding)

Alarm coil (1)	
two terminal line	1050-1250 ohms
three terminal line	700-900 ohms
Alarm coil (2)	2200-2600 ohms
Trip coil (3)	1800-2200 ohms
Ground Alarm coil (5)	5200-5800 ohms

PM-4 and PM-23 Resistance

Nominal PM-4 and PM-23 total resistance when adjusted for service is 20,000 ohms less pilot wire loop resistance at 1 ma.

PMA, PMA-1 and AC PMG-13, PM-13 Burden

0.5 VA at tap voltage	-	2-terminal line relay
1.0 VA at tap voltage	-	3-terminal line relay

Rectifiers

Approximate forward resistance - 560 ohms at 1 ma
300 ohms at 2 ma

Rating

Continuous forward	
current - amperes	- 1
Continuous back	
voltage - rms volts	- 200

Remote Tripping

Remote trip resistors are listed in Table II and III for 48, 125, and 250 volts d-c.

The relays have sufficient thermal capacity to withstand 20 MA d-c continuously when remote tripping. Nominal trip currents in the tripping relays are 5.0 MA d-c with 48, 125, and 250 volts d-c supply and a 2000-ohm pilot wire.

TABLE II

**PMA, PMA-1, PMD, AND PMD-1 APPLICATIONS
EXTERNAL RESISTORS FOR D.C. REMOTE TRIPPING
(2 REQUIRED PER STATION)**

# LINE TERMINALS	D.C. VOLTAGE	STATION A PMA or PMA-1	STATION A PMD or PMD-1	STATION B PM-2 & PM-3 or PM-23 or PM-4	STATION C PM-2 & PM-3 or PM-23 or PM-4	TO OPERATE
2	48	200	200	—	—	PM-23 or PM-3
	125	3550	3550	—	—	"
	250	9300	9300	—	—	"
3	48	200	200	—	—	"
	125	2000	2000	—	—	"
	250	5600	5600	—	—	"

TABLE IIIA

**PMG-13 AND PM-13 (D.C. SUPPLY) APPLICATIONS
RESISTORS FOR D.C. REMOTE TRIPPING
(2 REQUIRED PER STATION)**

# LINE TERMINALS	D.C. VOLTAGE	STATION A PMG-13 or PM-13	STATION B PM-2 & PM-3 or PM-23 or PM-4	STATION C PM-2 & PM-3 or PM-23 or PM-4	TO OPERATE
2	48	200 †	200	—	PMG-13 or PM-13 and PM-23 or PM-3
	125	2120 †	2120	—	"
	250	5600 †	5600	—	"
3	48	200 †	200	200	"
	125	1500 †	1500	1500	"
	250	4000 †	4000	4000	"

† Mounted in Relay

TABLE IIIB

**PMG-13 AND PM-13 (A.C. SUPPLY) APPLICATIONS
(2 REQUIRED PER STATION)
RESISTORS FOR D.C. REMOTE TRIPPING**

# LINE TERMINALS	D.C. VOLTAGE	STATION A PMG-13 or PM-13	STATION B PM-2 & PM-3 or PM-23 or PM-4	STATION C PM-2 & PM-3 or PM-23 or PM-4	TO OPERATE
2	48	200 †	200	—	PMG-13 or PM-13 and PM-23 or PM-3
	125	2120 †	2120	—	"
	250	5600 †	5600	—	"
3	48	200 †	200	200	"
	125	1500 †	1500	1500	"
	250	4000 †	4000	4000	"

† Mounted in Relay

TABLE IV

NOMINAL CALIBRATION VALUES - TWO TERMINAL LINES

RELAY	LOW CURRENT ALARM ¹	HIGH CURRENT ALARM ²	TRIP
PMA or PMA-1	0.7 ma	1.3 ma	-
PMD or PMD-1	0.7	1.3	-
PM-5 †	-	±0.3	-
PMG-13 or PM-13	0.7 ††	1.3 ††	14 V.
PM-23 or PM-2 & PM-3 †	0.7	-	14 V.

† Same relay as for three-terminal lines

†† These are pilot-wire current values

1 - Left-hand contacts, front view.

2 - Right-hand contacts, front view.

TABLE V

NOMINAL CALIBRATION VALUES - THREE TERMINAL LINES

RELAY	LOW CURRENT ALARM	HIGH CURRENT ALARM	TRIP
PMA or PMA-1	1.7 ma	2.3 ma	-
PMD or PMD-1	1.7	2.3	-
PM-5 †	-	±0.3	-
PMG-13 or PM-13	1.7 ††	2.3 ††	14 V.
PM-23 or PM-2 & PM-3 †	0.7	-	14 V.

† Same relay as for two-terminal lines

†† These are pilot-wire current values

Trip Circuit

The main contacts will safely close 30 amperes at 250 volts d-c and the seal-in contacts of the indicating contactor switch will safely carry this current long enough to trip a circuit breaker.

The indicating contactor switch has two taps that provide a pickup setting of 0.2 or 2 amperes. To change taps requires connecting the lead located in front of the tap block to the desired setting by means of a screw connection.

Trip Circuit Constant

Indicating Contactor Switch (ICS)

0.2 ampere tap 6.5 ohms d-c resistance

2.0 ampere tap 0.15 ohms d-c resistance

SETTING THE RELAY

Operating units of all relays are adjusted in the factory to the values listed in Tables IV and V to a tolerance of ±5%. No settings are required on these units.

For all 48/125-volt d.c. relays, connect jumpers across resistors as shown on the internal schematics.

PM-4, PM-2, and PM-23 Relays

Adjust the resistors in the PM-4, PM-2, or PM-23 relay or relays to a value of 1 MA d-c with the monitoring circuits connected for service. Use the milliammeter in the PM-23 for this purpose or use a portable milliammeter with a resistance of less than 200 ohms. Where it is not practical on three-terminal lines to adjust both receiving relays simultaneously, set one receiving relay for 18,000 ohms total resistance (including relay coil and resistors) by measurement prior to final adjustment of the other receiving relay. This procedure will minimize the change in monitoring current in the first relay to be adjusted when making the final adjustment of the second relay.

PMA, PMA-1, PMG-13 and PM-13 Relays

Select the transformer tap nearest to expected normal a-c supply voltage. The full wave rectifier is

TYPE PM MONITORING RELAYS

connected to a secondary transformer tap. Where desired, the output voltage can be raised about 5% by reconnecting across the full secondary winding.

Indicating Contactor Switch

No setting is required on the ICS unit except the selection of the 0.2 or 2.0 ampere tap setting. This selection is made by connecting the lead located in front of the tap block to the desired setting by means of the connecting screw. When the relay energizes a type WL relay switch, or equivalent, use the 0.2 ampere tap.

INSTALLATION

The relays should be mounted on switchboard panels or their equivalent in a location free from dirt, moisture, excessive vibration, and heat. Mount the relay vertically by means of the four mounting holes on the flange for semi-flush mounting or by means of the rear mounting stud or studs for projection mounting. Either a mounting stud or the mounting screws may be utilized for grounding the relay. The electrical connections may be made directly to the terminals by means of screws for steel panel mounting or to the terminal studs furnished with the relay for thick panel mounting. The terminal studs may be easily removed or inserted by locking two nuts on the stud and then turning the proper nut with a wrench.

For detailed FT case information, refer to I.L. 41-076.

Where the potential to ground impressed on the relays can exceed 700 volts, a drainage reactor in conjunction with a KX-642 tube, or the reactor in conjunction with 700 volt carbon-block arresters, is recommended. For details, see Protection of Pilot-Wire Circuits, AIEE Committee Report, paper 58-1190, AIEE Transactions, 1959, Volume 78, Part III B pp. 205-212. Also, see AIEE Special Publication S-117, Applications and Protection of Pilot-Wire Circuits for Protective Relaying, July 1960.

ADJUSTMENTS AND MAINTENANCE

The proper adjustments to insure correct operation of this relay have been made at the factory and should not be disturbed after receipt by the customer. If the adjustments have been changed, the relay taken apart for repairs, or if it is desired to check the adjustments at regular maintenance periods, the instructions in the succeeding sections should be followed.

Acceptance Tests

The following tests are recommended when the relay is received from the factory. If the relay does not perform as specified below, the relay either is not properly calibrated or it contains a defect.

Indicating Contactor Switch (ICS)

Close the contact of the tripping unit and pass sufficient direct current through the trip circuit to close the contacts of the ICS unit. This value of current should not be greater than the particular ICS tap setting being used (0.2 or 2.0). The indicator target should drop freely.

PMA and PMA-1 Relays

Alarm Unit (1)

Set the primary tap on 120 volts. Connect a variable resistor of approximately 20,000 ohms in series with a low-range d-c milliammeter across terminals 6 and 7 with the instrument positive connected to terminal 7. Apply 120 volts at rated frequency to terminals 4 and 5. Adjust the 20,000-ohm resistor to obtain a current of one ma. d.c. For a three-terminal line relay, use a 10,000-ohm resistor and set the current to 2 ma. d.c. At this value, the moving contact of the alarm or monitoring relay unit (1) should float between the two sets of stationary contacts. In the PMA relay, the ground alarm unit (5) contact should also float. (This contact will also float when the relay is de-energized.) Increase and decrease the one or two-milliamper monitoring current to check the calibration values listed in Tables IV and V.

Ground Unit (5)

Reconnect the 20,000-ohm resistor. For the PMA relay only, short terminals 7 and 3. The contact of the ground alarm unit (5) should close to the right when the relay is energized. Remove the short, and connect it between terminals 6 and 3. The ground alarm unit (5) should close to the left. The action of the monitoring unit (1) contact is of no significance in this simulated pilot-wire ground test. To check the pickup current of the ground detector, first remove the 20,000-ohm resistor from terminals 6 and 7. Connect a 0-1 d.c. milliammeter in series with a variable resistor of about 50,000 ohms between terminals 3 and 6. The ground unit should close its left-hand contact at approximately 0.3 ma. d.c. With the milliammeter and resistor connected between terminals 3 and 7, the right-hand contact should close at 0.3 ma. d.c.

TYPE PM MONITORING RELAYS

PMD and PMD-1 Relays

Alarm and Ground Units

Connect an adjustable 20,000-ohm resistor (or 10,000-ohms for a 3-terminal relay) in series with a d-c milliammeter across terminals 6 and 7 with the instrument positive connected to terminal 7. Apply rated d-c voltage to terminals 8 and 9 with positive on terminal 9. Now check the PMD and PMD-1 relays, following the procedure given in the previous section for the PMA and PMA-1 relays, respectively. Note, however, that terminal 5 of the PMD relay corresponds to terminal 3 of the PMA relay.

PM-2, PM-3, and PM-23 Relays

Alarm Unit (2)

Apply a variable d-c voltage of approximately 20 volts to relay terminals 8 and 9 (terminal 9 positive) of the PM-2 or PM-23 relay. Adjust the voltage to obtain a reading of one ma. on the relay milliammeter. The monitoring polar unit (2) contacts should float. Reduce the current gradually. The monitoring alarm contacts should close at 0.7 ma. d.c. The tripping unit (3) of the PM-23 relay should not move during this test. The milliammeter has been adjusted to read 1 ma. $\pm 5\%$. As a result the pointer may not read zero for a zero current condition.

Tripping Unit (3)

To check the PM-3 relay or the tripping unit of the PM-23 relay, apply the variable d-c voltage in series with an external milliammeter to relay terminals 8 and 9 with terminal 8 positive for the PM-23 relay, or terminal 9 positive for the PM-3 relay. When checking the pickup of the PM-23 trip unit block open the alarm unit contacts (2) so as to remove the shunt resistor from around the trip coil (3).

The tripping relay unit (3) should pick up with positive action at 14 volts d.c. and should drop out at approximately 10 volts. The alarm unit of the PM-23 relay will not operate during this test.

PM-4 Relay

This device is simply a set of resistors and a diode to connect into the pilot-wire circuit to provide a path for the monitoring current. The resistors can be checked with an ohmmeter, and the diode can be checked either with an ohmmeter, or as explained in the section entitled "Rectifier Check" under "Routine Maintenance". If an ohmmeter is used, the difference in forward and reverse resistance readings obtained will be dependent on the current flowing through the diode.

PM-5 Relay

Apply 5 volts d.c. in series with a 0-1 d.c. milliammeter and a 20,000-ohm variable resistor to terminals 6 and 7 with positive on terminal 6. The left-hand contact should close at approximately 0.3 ma. Now apply the same circuit to terminals 8 and 9 with positive on terminal 9. The right-hand contact should close at approximately 0.3 ma.

PM 13 Relays - A.C. and D.C.

Alarm Unit (1)

Connect a variable 20,000-ohm resistor (10,000 ohms for a 3-terminal-line relay) in series with a d-c milliammeter across terminals 8 and 9 with the instrument positive on terminal 9. For the a-c relay, set the primary tap on 120 volts. Now apply the rated supply voltage to terminals 4 and 5. This will be 48, 125, or 250 volts d.c., or 120 volts a.c. as indicated on the relay nameplate. Adjust the variable resistor to obtain a current of one ma. for a 2-terminal line relay, or 2 ma. for a 3-terminal relay. At this value, the moving contacts of the alarm or monitoring (1) relay unit (the upper polar unit) should float between the two sets of stationary contacts. Increase and decrease the one or 2 ma. monitoring current to check the calibration values listed in Tables IV and V.

Tripping Unit (3)

To check the operation of the tripping unit 3 (the lower polar unit), apply a d.c. potential across terminals 16 (positive) and 20 (negative). The tripping polar unit should pick up at 14 volts, and should drop out at approximately 10 volts. The resistance of the series dropping resistors for transferred tripping (listed in Tables III A and III B) can be checked with an ohmmeter. The circuit location of these resistors can readily be seen from the external schematic, Figure 27.

PMG-13 Relays - A.C. and D.C.

Alarm and Tripping Units

Follow the procedure given in the previous section for the a-c. and d-c. PM-13 relays.

Ground Unit (5)

Connect the 20,000-ohm (or 10,000-ohm) resistor and milliammeter across terminals 8 and 9. With rated voltage applied and one ma. (or 2 ma.) flowing, successively short circuit terminals 3 and 8, then 3 and 9. The ground alarm unit 5 (lower polar unit) should move first to the left, then to the right. To check the pickup current of the ground detector, first remove the 20,000-ohm resistor from terminals 8 and 9. Connect a 0-1 d.c. milliammeter in series

with a variable resistor of about 50,000 ohms between terminals 3 and 8. The left-hand contact should close at approximately 0.3 ma. d.c. With the milliammeter resistor connected, between terminals 3 and 9, the right-hand contact should close at 0.3 ma. d.c. The external schematic diagrams for these relays are shown in Figures 27 and 29.

Routine Maintenance

CAUTION - Do not make any performance check, calibration tests, or adjustments while the PM relays are energized or connected to the pilot wires, to prevent the possibility of inadvertently causing a break operation. The PM relays may be removed from service for testing, without jeopardizing HCB relay protection, providing that the connections between the 10-mfd capacitor and the HCB insulating transformer are not disturbed.

Contacts

All contacts should be periodically cleaned. A contact burnisher S#182A836H01 is recommended for this purpose. The use of abrasive material for cleaning contacts is not recommended because of the danger of embedding small particles in the face of the soft silver and thus impairing the contact.

Operational Check

In addition to cleaning contacts, it is recommended that an operational check be performed periodically by opening and short-circuiting the pilot wires, as well as grounding them at the relay terminals. **Note:** These pilot-wire faults should not be applied directly to the pilot wires when the HCB relays are in service. It is also recommended that the trip circuits of the PM relays be opened (where tripping is used), to prevent the possibility of inadvertently tripping the associated circuit breaker during testing. If the relays do not perform as expected, and diode failure is suspected, the diode tests described in the following section may be performed.

Rectifier (Diode) Check

If there is suspicion of a rectifier (diode) failure, apply 30 volts d.c. reverse voltage (positive on arrow-head) through a 300-ohm resistance to the diode. Measure the voltage across the diode. If this voltage is not essentially 30 volts, the diode is short-circuited. Now apply 30 volts d.c. in the forward direction through the 300-ohm resistor, and measure the voltage across the resistor. If the voltage is not essentially 30 volts, the diode may have a high forward resistance. If the voltage is zero, the diode is open-circuited.

Calibration

If the relay has been dismantled or the calibration has been disturbed, use the following procedure for calibration.

With the permanent magnet removed, see that the moving armature floats in the central area of the air-gap between the poles of the polar unit frame. If necessary, loosen the core screw in the center rear of the unit and shift the core and contact assembly until the armature floats. (This can best be done with the polar unit removed from the relay.) Then retighten the core screw and replace the permanent magnet with the dimple (north pole) on the magnet to the left when viewed from the front.

Polar Units-General

The following mechanical adjustments are given as a guide, and some deviation from them may be necessary to obtain proper electrical calibration.

Magnetic Shunt Adjustment

The sensitivity of the polar unit is adjusted by means of two magnetic, screw-type shunts at the rear of the unit, as shown in Fig. 1. These shunt screws are held in proper adjustment by a flat strip spring across the back of the polar unit frame, so no locking screws are required. Looking at the relay, front view turning out the right-hand shunt to open the right-hand air gap decreases the amount of current required to close the right-hand contact. Conversely, drawing out the left-hand shunt increases the amount of current required to close the right-hand contact, or decreases the amount of current required to close the left-hand contact (with the proper direction of current flow). Also, if a relay trips to the right at the proper current, the dropout current can be raised by turning in the right-hand shunt. The two shunt-screw adjustments are not independent, however, and a certain amount of trimming adjustment of both shunt screws is generally necessary to obtain the desired pickup and dropout calibration.

In general, the farther out the two shunt screws are turned, the greater the toggle action will be, and as a result, the lower the dropout current. For the tripping units (3) of the PM-3, PM-13, and PM-23 relays, toggle action is desirable, with a dropout current around 75 percent of the pickup current. For the monitoring alarm relay units, toggle action is not desired. Instead, the armature is adjusted to float between the pole faces at a given current (1 or 2

TYPE PM MONITORING RELAYS

The following chart indicates the units present in each relay.

FUNCTION AND UNIT	PMA PMD	PMA-1 PMD-1	PM2	PM3	PM4	PM5	PM13	PMG13	PM23
Alarm for p.w. open, short or reversal (1) (2)	X	X	X				X	X	X
Transfer - Trip Unit (3)				X			X	X	X
Alarm for p.w. ground (5)	X					X		X	
D.C. Path for Monitoring Current					X				

ma.), and to move gradually toward the high or low-current alarm as the coil current is increased or or decreased. Similarly, the floating adjustment of of the armature of the ground alarm unit (5) requires that both shunt screws be turned in relatively far. Then the armature will move gradually to the left or right as the current through the two #5 coils is unbalanced.

The electrical calibration of the polar unit is also affected by the contact adjustment as this changes the position of the polar unit armature. Do not change the contact adjustment without rechecking the electrical calibration.

Contact Adjustment - All Relays

For all monitoring alarm units, designated (1) or (2), turn in all the stationary contact and contact stop screws until they just touch the moving contact. Advance the screws to hold the armature in the central portion of the magnetic air gap between the two pole faces. (The stationary contact screws have a round silver contact face; the stop screws do not have this silver facing.) Now back off all the contact and contact stop screws one full turn. This will give a total contact travel of 0.050 inch. When the relay is properly calibrated, some touch-up adjustment may be necessary so that double contacts will both close at the same current value. The contact gap between the floating moving contact and the right-hand or left-hand stationary contacts or contact stops will be approximately 0.025 inch when the relay is in operation.

For the tripping (3) units of the PM-3, PM-13, PMG-13, and PM-23 relays, adjust the contacts as described in the previous paragraph, except back off the contact and stop screws one-half turn each to

give a total moving contact travel of approximately 0.025 inch. In operation of the tripping unit, the moving contact will normally rest against the contact stop screws, and will pick up only for a transferred-tripping operation.

For the pilot-wire ground alarm unit (5) of the PMA, PMD, PM5, and PMG-13 relays, follow the same general procedure except back off both stationary contact screws two turns each. This will give a contact gap of 0.050 on each side of the moving contact when it is its normal central position.

Electrical Calibration - All Relays

In the following sections, the calibration instructions are given for the polar unit which performs a certain function, such as alarm (1) or (2), ground (5), or trip (3), rather than giving calibration instructions for each complete relay. In this way, considerable duplication of instructions has been eliminated.

Alarm Unit (1)

Connect the relay as described under Acceptance Tests for the particular relay involved. Screw the two magnetic shunts all the way in, then back them out five turns each. With the relay energized at rated voltage, set the monitoring current at 1.3 or 2.3 ma. d.c. for 2 or 3-terminal relay respectively, by adjusting the external resistor. If the relay does not close its right-hand contact, turn in the left shunt screw until the right-hand contact just closes. If the right-hand contact is closed at 1.3 ma., turn in the right shunt until a point is reached when the right-hand contact is just closed at 1.3 ma.

Now drop the current to 0.7 ma. and adjust the opposite shunt until the left-hand contact just closes

TYPE PM MONITORING RELAYS

at 0.7 ma. d.c. At 1.0 ma. d.c., the moving contact should float half way between the two sets of station ary contacts with a 0.025-inch gap on each side. Re-check the high and low current calibration several times, touching up the shunt adjustments as required to obtain the desired calibration.

Polarization Check

For all the source relays, which are listed below, make the following additional calibration check:

- PMA PM-13 (a.c. and d.c.)
- PMA-1 PMG-13 (a.c. and d.c.)
- PMD
- PMD-1

After calibration as described in the previous sections, connect a 20,000 ohm resistor (or 10,000 ohms for 3-terminal applications) across the output terminals, and energize the relay at its rated supply voltage. With these connections, approximately one (or two) milliamperes d.c. will flow through the monitor relay coils and external resistor, thus representing normal operating conditions.

Now momentarily (one second or so) apply 48 volts d.c. directly to the pilot-wire terminals of the relay, as indicated in the following table.

<u>Relay</u>	<u>Terminals for Momentary Application of 48 V. d.c.</u>	
	<u>POS.</u>	<u>NEG.</u>
PMA, PMA-1 } PMD, PMD-1 }	6	7
PM-13 (a.c. or d.c.) } PMG-13 (a.c. or d.c.) }	8	9

After momentary application of the transfer-trip voltage as just explained, recheck the calibration of the monitoring alarm unit (1). If it has changed, make necessary trimming adjustments of the shunt screws until there is no change in calibrating of the alarm unit (1) after the transfer-trip voltage has been applied. The purpose of this test is to compensate for the small residual magnetism in the relay unit. The ground alarm unit (5) will not be affected by this test as the ampere-turns of the two windings cancel each other.

Alarm Unit (2)

For the alarm unit of the PM-2 or PM-23 relays, adjust the shunts so that the relay moving contact

floats at one ma. d.c., and closes the left-hand contact at 0.7 ma. d.c. The moving contact should float midway between the contact and contact stop at 1.0 ma. d.c. There is no high-current calibration for this relay unit.

Now apply 48 volts d.c. momentarily (one second or so) across the alarm unit coil-circuit terminals in a direction to operate the alarm relay. Then recheck the alarm unit calibration. If there is any change, touch up the shunt adjustments until there is no change in calibration after 48 v. d.c. has been applied.

Tripping Unit (3)

To calibrate the tripping unit of the PM-3, PM-13, PMG-13, or PM-23 relays apply a d.c. voltage as explained below, to the following relay terminals:

Relays	D.C.	Voltage
	Pos.	Neg.
PM-3	9	8
PM-13 (a.c. or d.c.)	16	20
PMG-13 (a.c. or d.c.)	8	9
PM-23	8	9

Momentarily (one second or so) apply 48 volts dc to the terminals shown in the chart. Then starting with both shunts all the way in, turn out the right-hand shunt screw until the relay closes its right-hand trip contact at 14 volts dc. Note: In the calibration of a PM-23 the alarm unit (2) contact must be blocked open so as not to affect the tripping unit pickup. (This will give approximately 2 ma. through the relay coil.) Now draw out the left-hand shunt until the relay resets with toggle action (not gradually) at not less than 10 volts dc. When the calibration is approximately correct, again apply 48 volts dc to the indicated terminals, then recheck the pickup and dropout voltage, making any necessary trimming adjustments of the shunts. When the relay is properly adjusted, the application of 48 volts dc will not change the pickup or dropout voltage points. The relay should trip and reset with toggle action in this application. This will require both shunt screws to be withdrawn farther than for floating action.

Ground Alarm Unit (5)

For the PM-5 relay, turn both shunt screws all the way in, then back them out five turns each. Pass a current of 0.3 ma. d.c. in terminal 6 and out terminal 7. Following the same general procedure as described previously in the section entitled "Alarm Unit (1)," adjust the shunt screws so that the left-hand contact closes at 0.3 ma. Now pass 0.3 ma. d.c.

TYPE PM MONITORING RELAYS

in terminal 9 and out terminal 8, and adjust for closing of the right-hand contact at 0.3 ma. Recheck both pickup points several times, and make trimming adjustments of both shunts as required to obtain contact closing at 0.3 ma. d.c. in each direction.

For the ground unit (5) of the PMA, PMD, and PMG-13 relays, connect a variable resistance of about 50,000 ohms in series with a 0-1 d.c. milliammeter between the terminals indicated in the following table:

Turn the shunts all the way in, then back them out five turns each. With the relay connected as shown in the left-hand column of the table, apply rated voltage to the relay and adjust the 50,000-ohm resistor for 0.3 ma. d.c. Now following the procedure in the previous paragraph for the PM-5 relay, adjust the shunts until the left-hand contact closes at 0.3 ma. d.c. Change the connections as indicated in the right-hand column, and adjust the opposite shunt until the right-hand contact closes. Recheck back and forth several times and make necessary trimming adjustments to obtain pickup at 0.3 ma. In each direction. The armature will move gradually as the

current is changed for this relay unit.

ICS Unit

Close the main relay tripping contact circuit with a jumper connected directly across the contact terminals of the polar unit. Pass sufficient direct current through the relay trip circuit to close the contacts of the ICS unit. This value of current should not be greater than the ICS tap setting being used (0.2 or 2.0). The indicator target should drop freely. The contact gap should be approximately 0.047 inch between the bridging moving contact and the adjustable stationary contacts. The bridging moving contact should touch both stationary contacts simultaneously.

RENEWAL PARTS

Repair work can be done most satisfactorily at the factory. However, interchangeable parts can be furnished to the customers who are equipped for doing repair work. When ordering parts, always give the complete nameplate data.

Ground Alarm (5) Calibration		
Relay	<u>Relay Terminals</u>	
	L.H. Contact Check	R.H. Contact Check
PMA	3 ⁺ and 6	3 and 7 ⁺
PMD	5 ⁺ and 6	5 and 7 ⁺
PMG-13	3 ⁺ and 8	3 and 9 ⁺

+ Milliammeter positive to this terminal

INDEX TO FIGURES

INTERNAL SCHEMATICS

FIG. NO.		PAGE NO.
1	Polar Unit Permanent Magnet Flux Paths	2
2	PMA Relay - AC supply - two terminal line	14
3	PMA-1 Relay - AC supply - two terminal line	14
4	PMA Relay - AC supply - three terminal line	14
5	PMA-1 Relay - AC supply - three terminal line	14
6	PMD Relay - DC supply - two terminal line	15
7	PMD-1 Relay - DC supply - two terminal line	15
8	PMD Relay - DC supply - three terminal line	15
9	PMD-1 Relay - DC supply - three terminal line	15
10	PM-2 relay in FT21 case	16
11	PM-3 relay in FT11 case	16
12	PM-4 relay (auxiliary unit)	16
13	PM-5 ground detector relay	16
14	PM-23 relay in FT21 case	17
15	PM-13 Relay - DC supply - two terminal line	17
16	PM-13 Relay - DC supply - three terminal line	17
17	PM-13 Relay - AC supply - two or three terminal line	17
18	PMG-13 Relay - DC supply - two terminal line	18
19	PMG-13 Relay - DC supply - three terminal line	18
20	PMG-13 Relay - AC supply - two or three terminal line	18
21	PMG-13 Relay - DC Supply - with Telephone Relay Output - two terminal line	19
22	PMG-13 Relay - DC Supply - with Telephone Relay Output - three terminal line	19
23	PMD Relay - DC Supply - with Telephone Relay Output - two terminal line	19
24	PMD Relay - DC Supply - with Telephone Relay Output - three terminal line	19

EXTERNAL SCHEMATICS

25	PMD relay with PM-23 or PM-4, two terminal line	20
26	PMA relay with PM-23 or PM-4, two terminal line	20
27	DC type PMG-23 with PM-23 or PM-4, two terminal line	21
28	PMD relay with PM-23 and PM-4, three terminal line	21
29	AC type PMG-13 relay with PM-23, two terminal line	22
30	DC type PM-13 and PM-5 with PM-23 or PM-4, two terminal line	22
31	DC type PM-13 relay with PM-23 or PM-4, two terminal line	23

OUTLINE & DRILLING PLANS

32	10 mfd. capacitor	24
33	Remote trip resistor	24
34	PM-4 projection molded case	24
35	PM-4 semi-flush molded case	24
36	PM-3, PM-5, & PMD-1 in FT11 case	25
37	PM-2, PM-23, PMA-1, & PMD in FT21 case	26
38	PMA in FT31 case	27
39	PM-13 and PMG-13 in FT32 case	28

TYPE PM MONITORING RELAYS

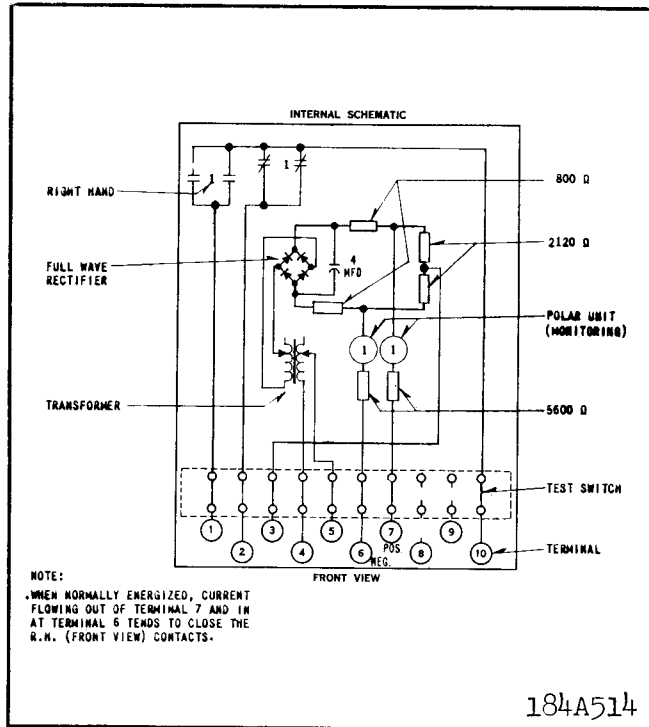
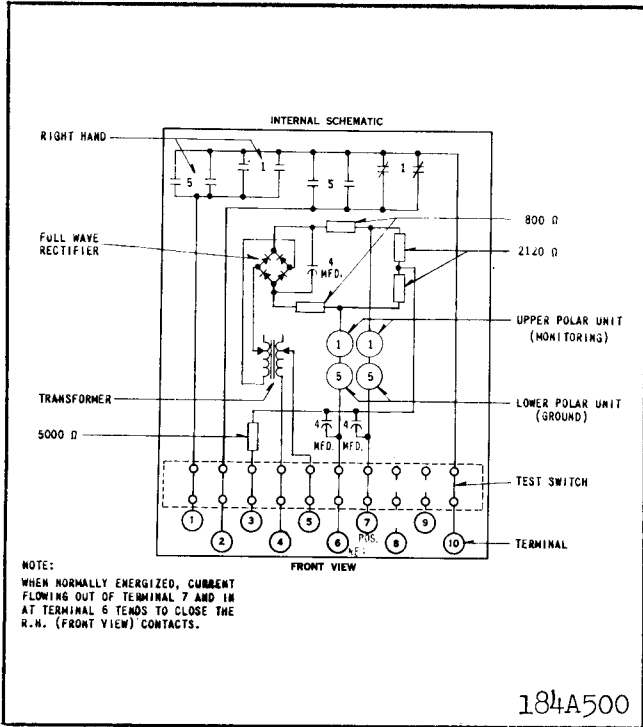

Fig. 2. Internal schematic of the type PMA relay in FT 31 case - 120 volt, 60 hertz supply - For two terminal lines.

Fig. 3. Internal schematic of type PMA-1 relay in the FT 21 case - 120 volts, 60 hertz supply - For two terminal lines.

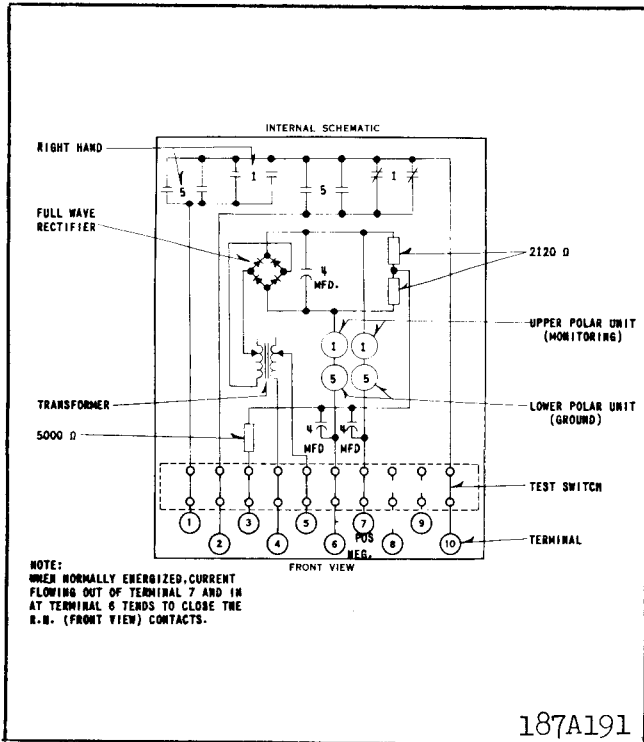

Fig. 4. Internal schematic of type PMA relay in FT 31 case - 120 volt, 60 hertz supply - For three terminal lines.

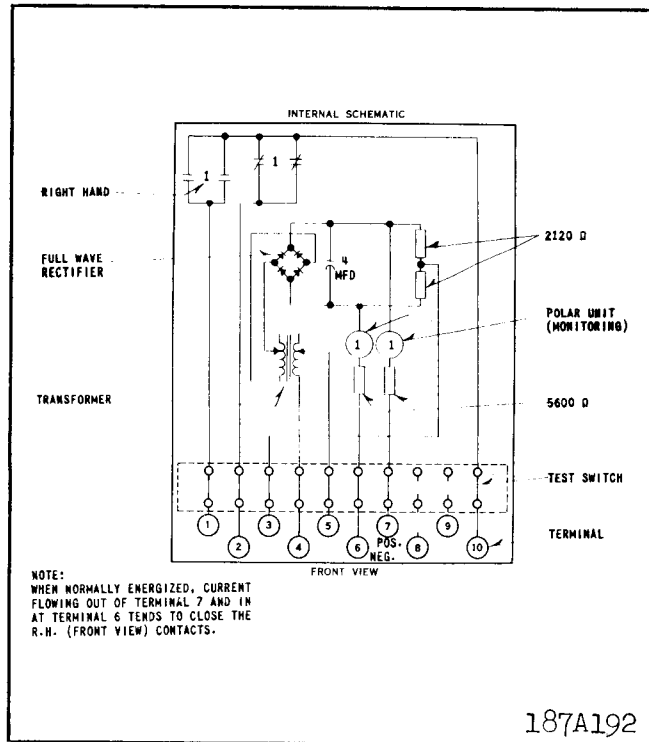
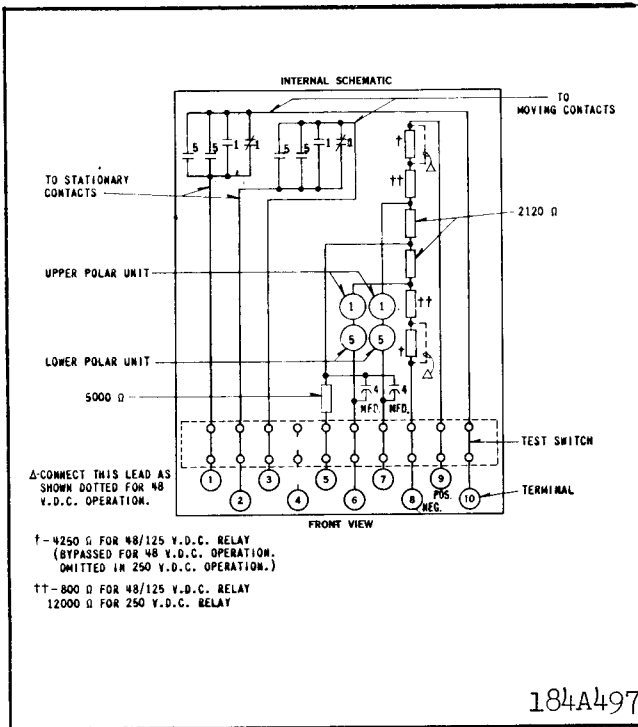
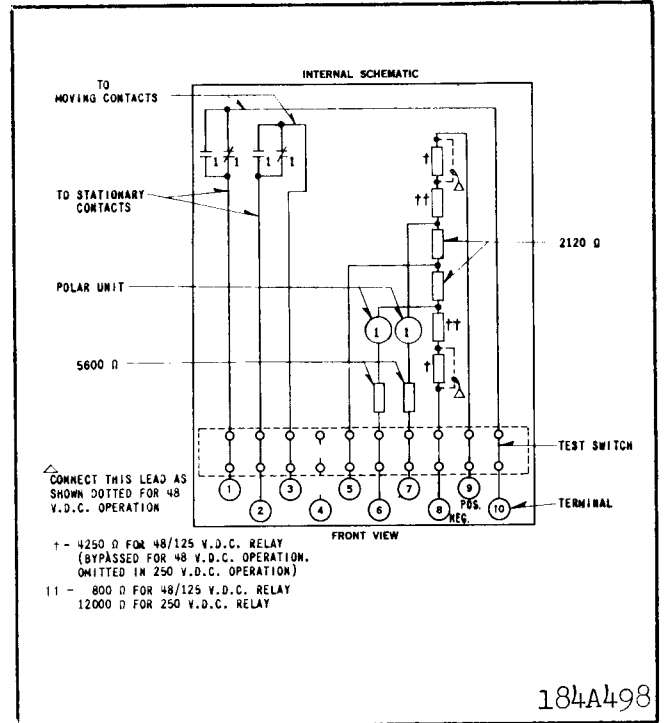

Fig. 5. Internal schematic of type PMA-1 relay in FT 21 case - 120 volt, 60 hertz supply - For three terminal lines.



184A497

Fig. 6. Internal schematic of the type PMD relay in FT 21 case - DC supply - for two terminal lines.



184A498

Fig. 7. Internal schematic of the type PMD-1 relay in the FT 11 case - DC supply - For two terminal lines.

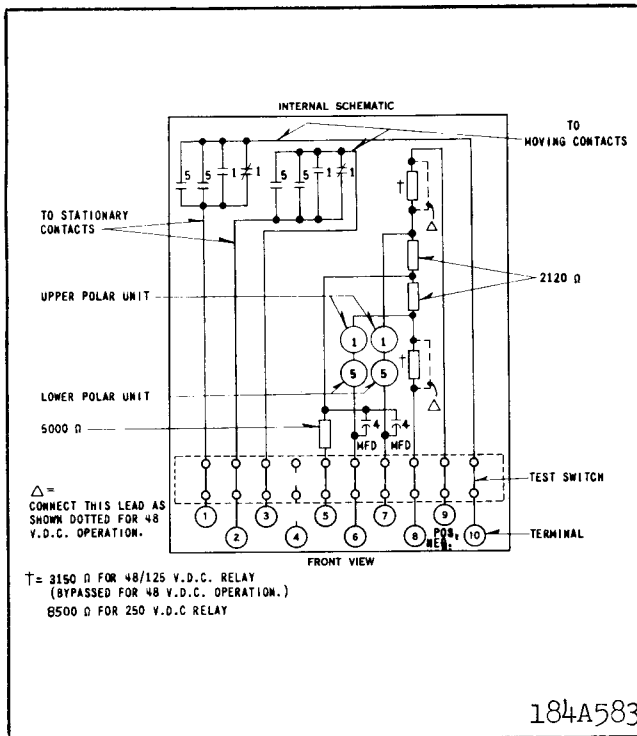

184A583

Fig. 8. Internal schematic of the type PMD relay in the FT 21 case - DC supply - For three terminal lines.

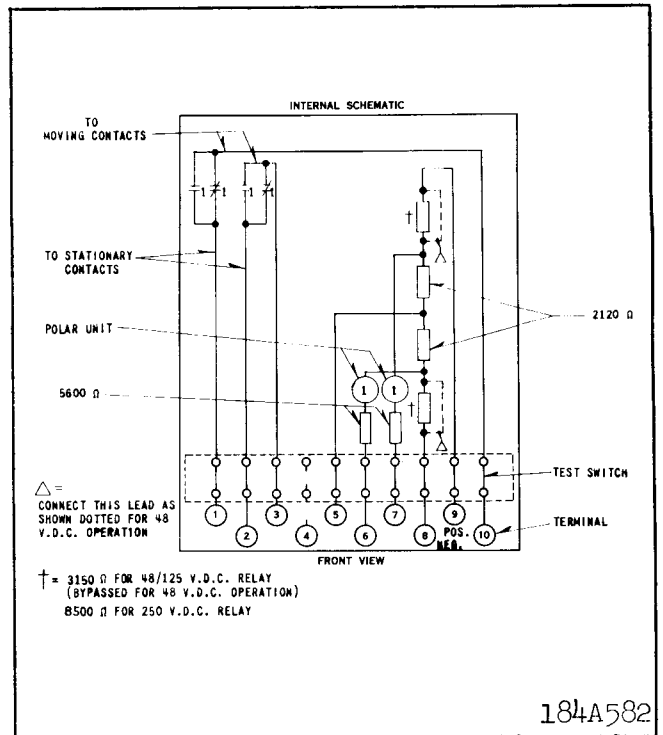

184A582

Fig. 9. Internal schematic of the type PMD-1 relay in the FT 11 case - DC supply - For three terminal lines.

TYPE PM MONITORING RELAYS

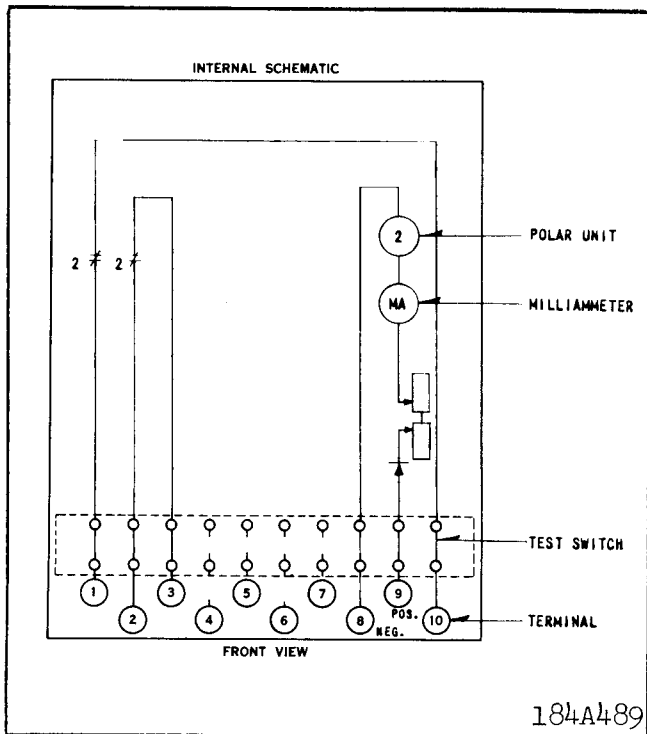

Fig. 10. Internal schematic of the type PM-2 relay in the FT 21 case.

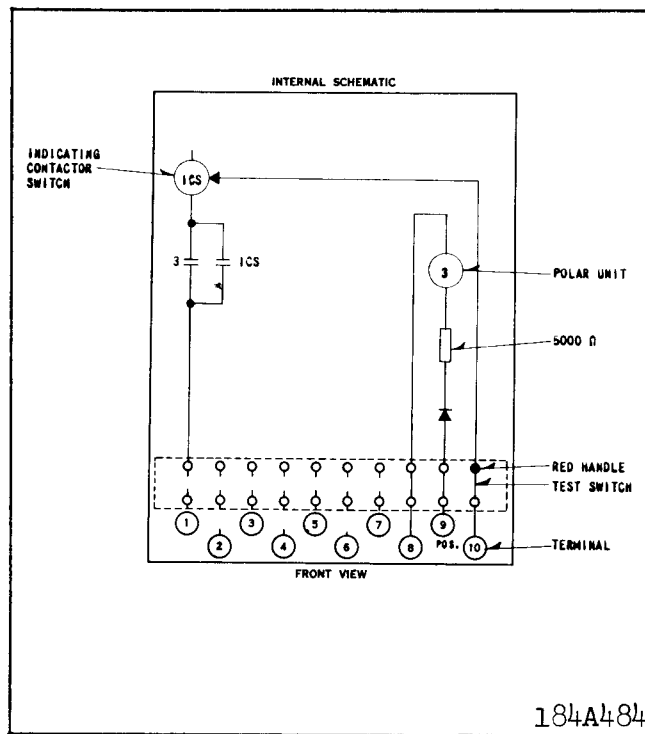

Fig. 11. Internal schematic of the type PM-3 relay in the FT 11 case.

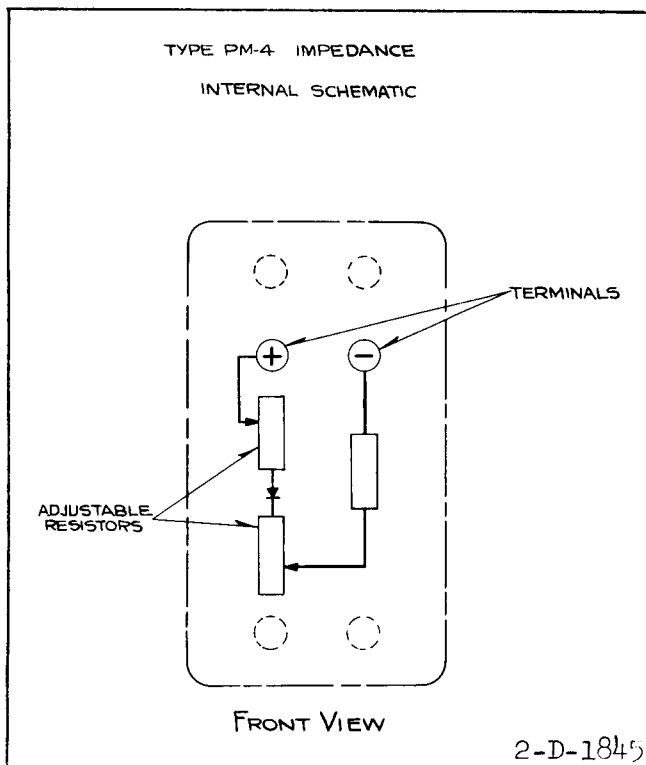

Fig. 12. Internal schematic of the type PM-4 Auxiliary Unit in the small molded case.

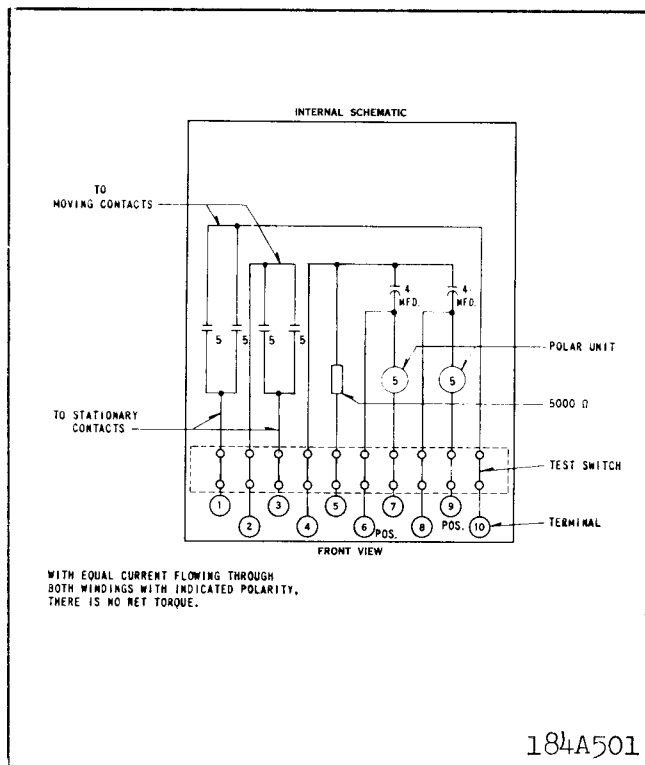
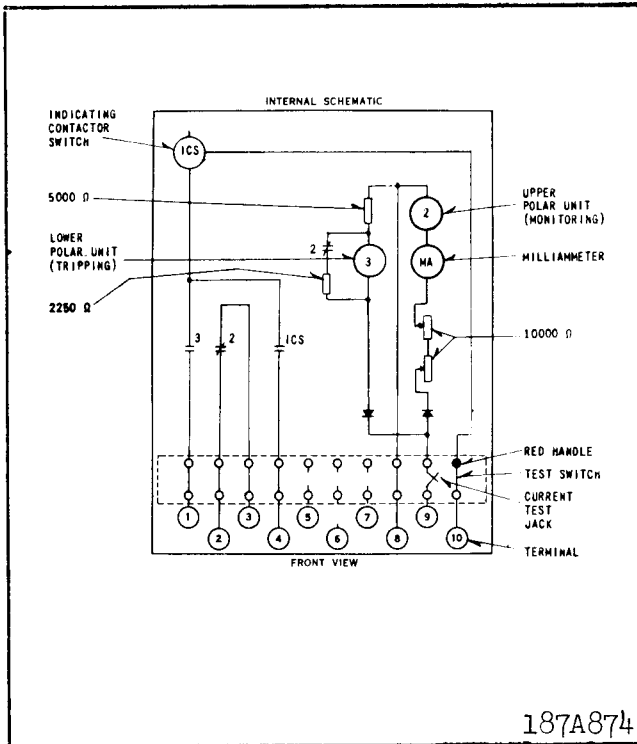
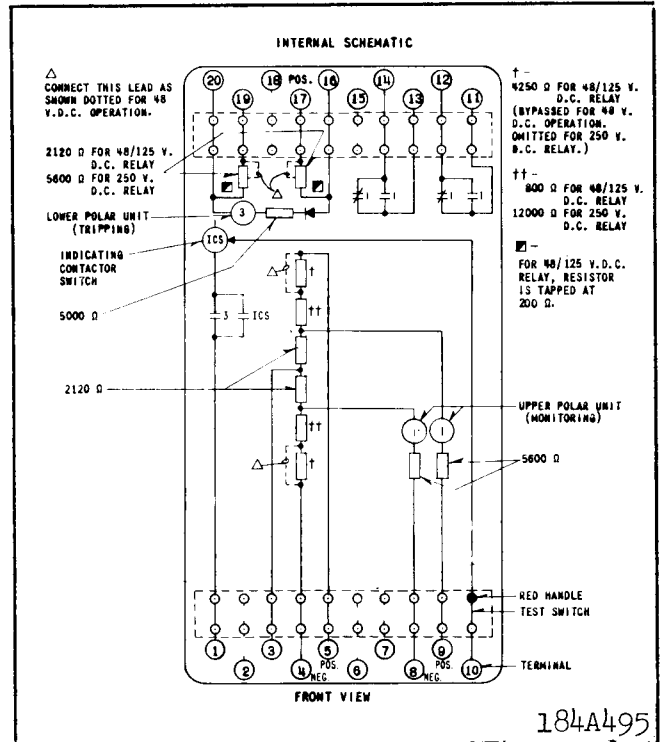

Fig. 13. Internal schematic of the type PM-5 ground detector relay in the FT 11 case.



187A874

Fig. 14. Internal schematic of the type PM-23 relay in the FT 21 case.



184A495

Fig. 15. Internal schematic of the type PM-13 relay in the FT 32 case - DC supply - For two terminal lines.

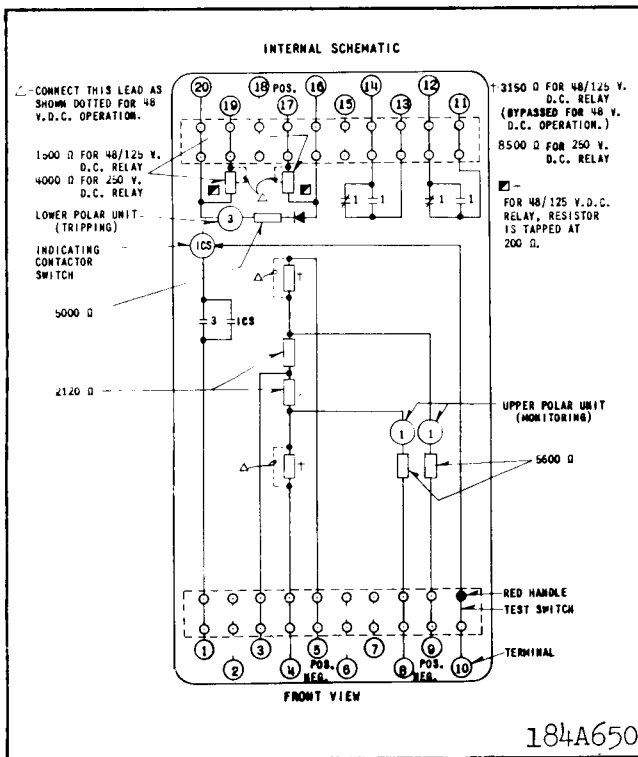

184A650

Fig. 16. Internal schematic of the type PM-13 relay in the FT 32 case - DC supply - For three terminal lines.

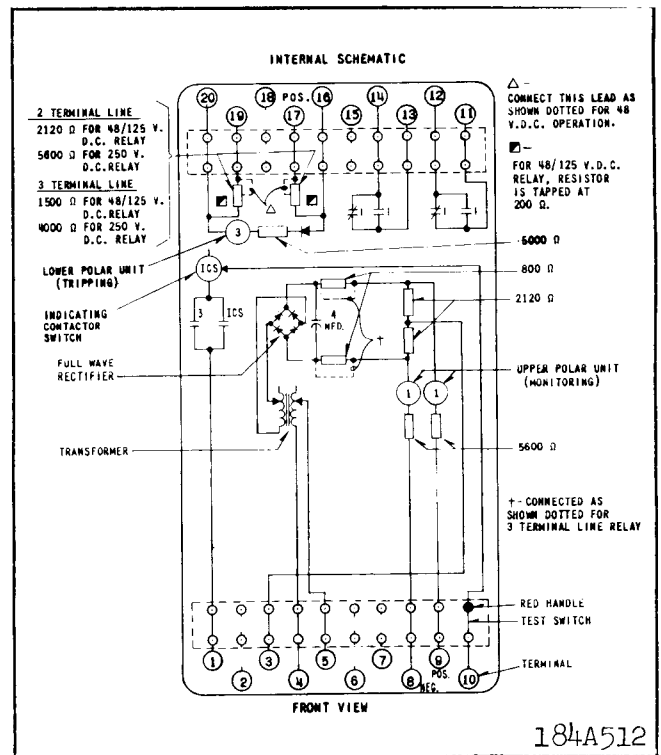

184A512

Fig. 17. Internal schematic of the type PM-13 relay in the FT 32 case - 120 volt, 60 hertz supply - For two or three terminal lines.

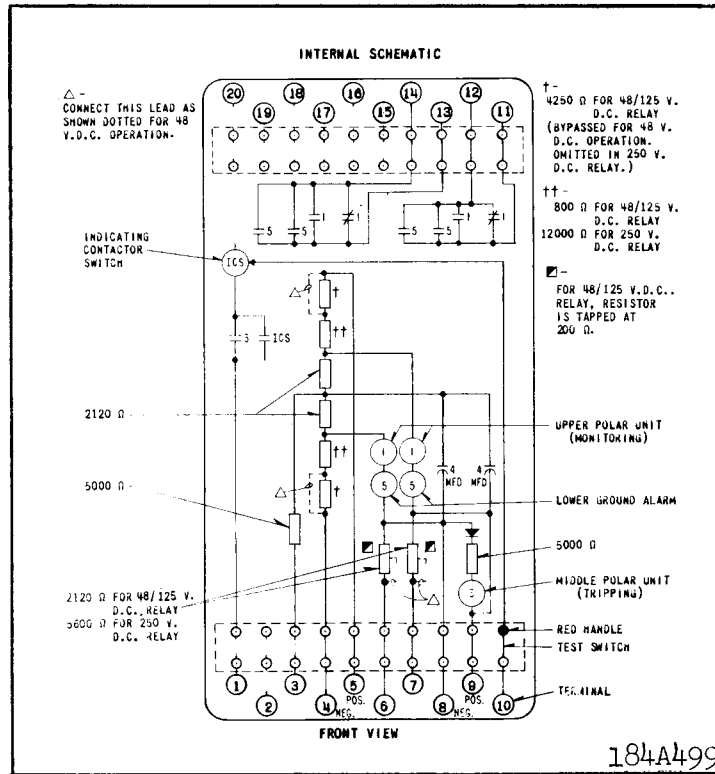

Fig. 18. Internal schematic of the type PMG-13 relay in the FT 32 case - DC supply - For two terminal lines.

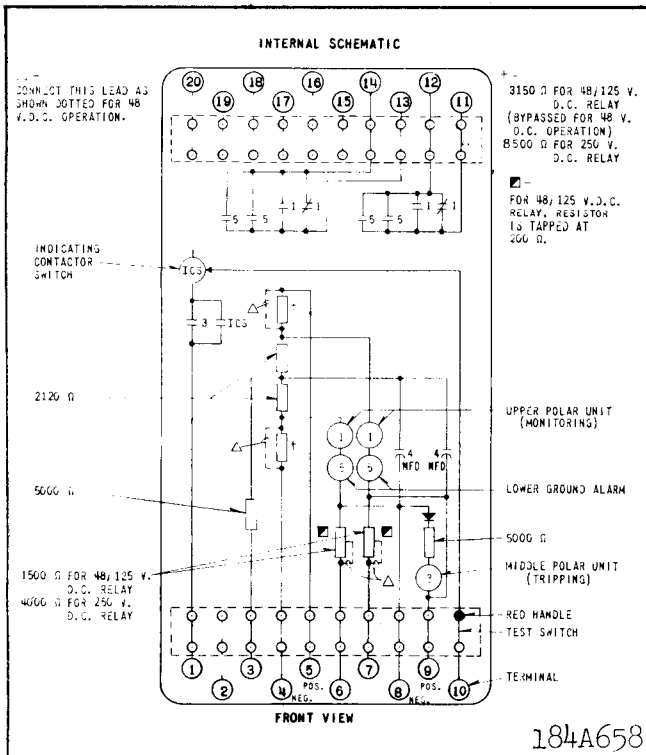

Fig. 19. Internal schematic of the type PMG-13 relay in the FT 32 case - DC supply - For three terminal lines.

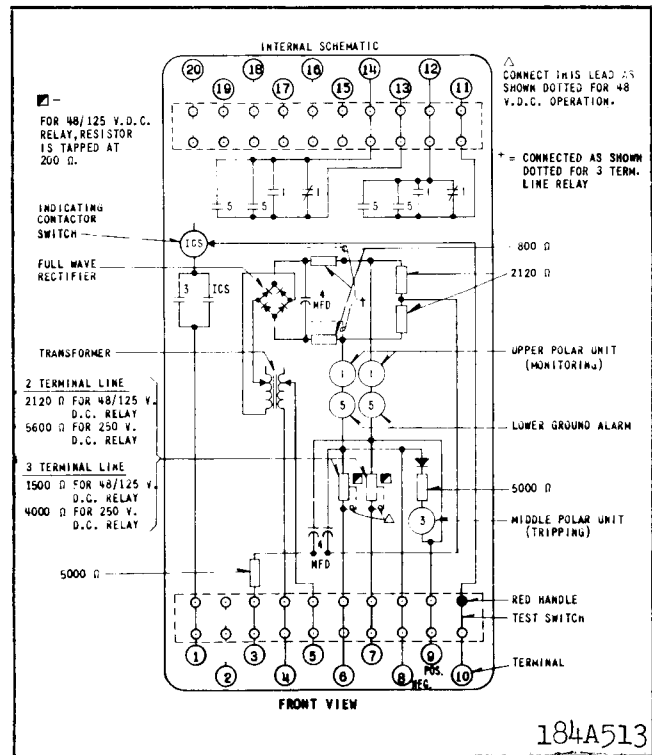

Fig. 20. Internal schematic of the type PMG-13 relay in the FT 32 case - 120 volt, 60 hertz supply - For two or three terminal lines.

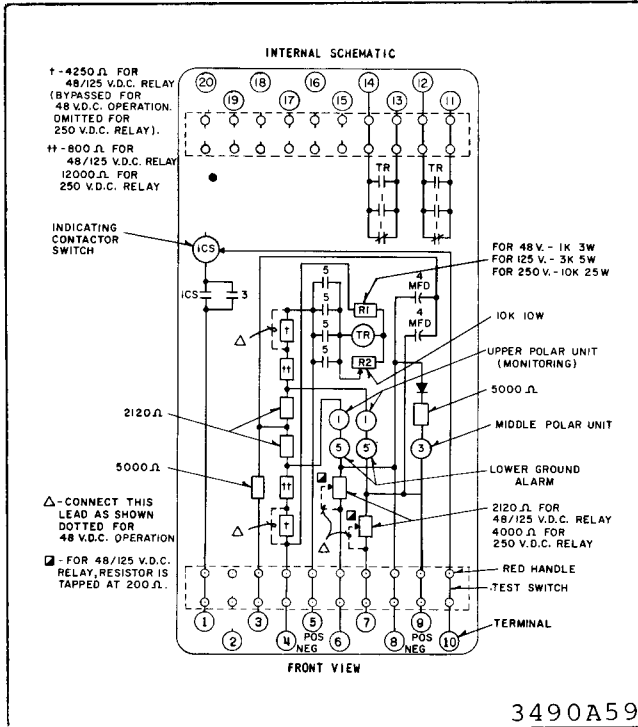

Fig. 21. PMG-13 Relay with Ground Alarm and Remote Trip - Two Terminal Lines with Telephone Relay Output. FT-32 Case.

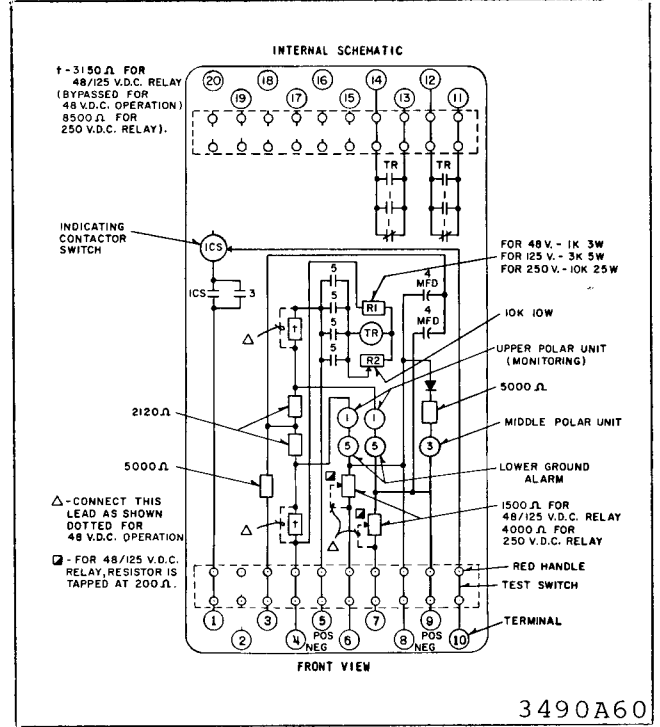

Fig. 22. PMG-13 Relay with Ground Alarm and Remote Trip - Three Terminal Lines with Telephone Relay Output - FT-32 Case.

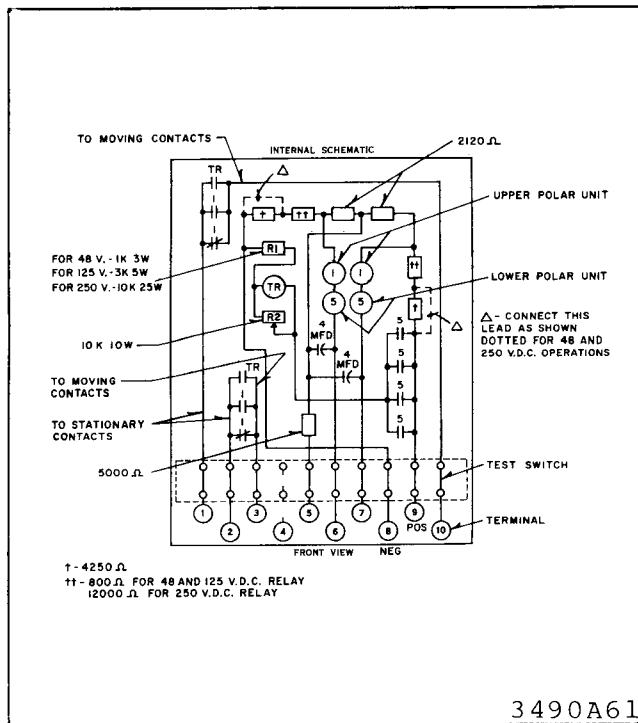

Fig. 23. PMD Relay - Ground Alarm, D.P.D.T. Contacts, Two Terminal Lines with Telephone Relay Output - FT-21 Case.

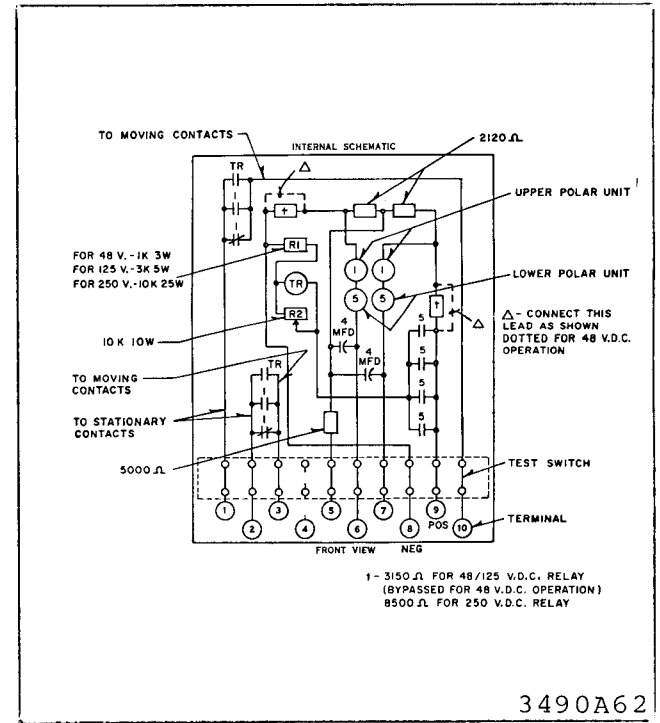

Fig. 24. PMD Relay - Ground Alarm, D.P.D.T. Contacts, Three Terminal Lines with Telephone Relay Output - FT-21 Case.

TYPE PM MONITORING RELAYS

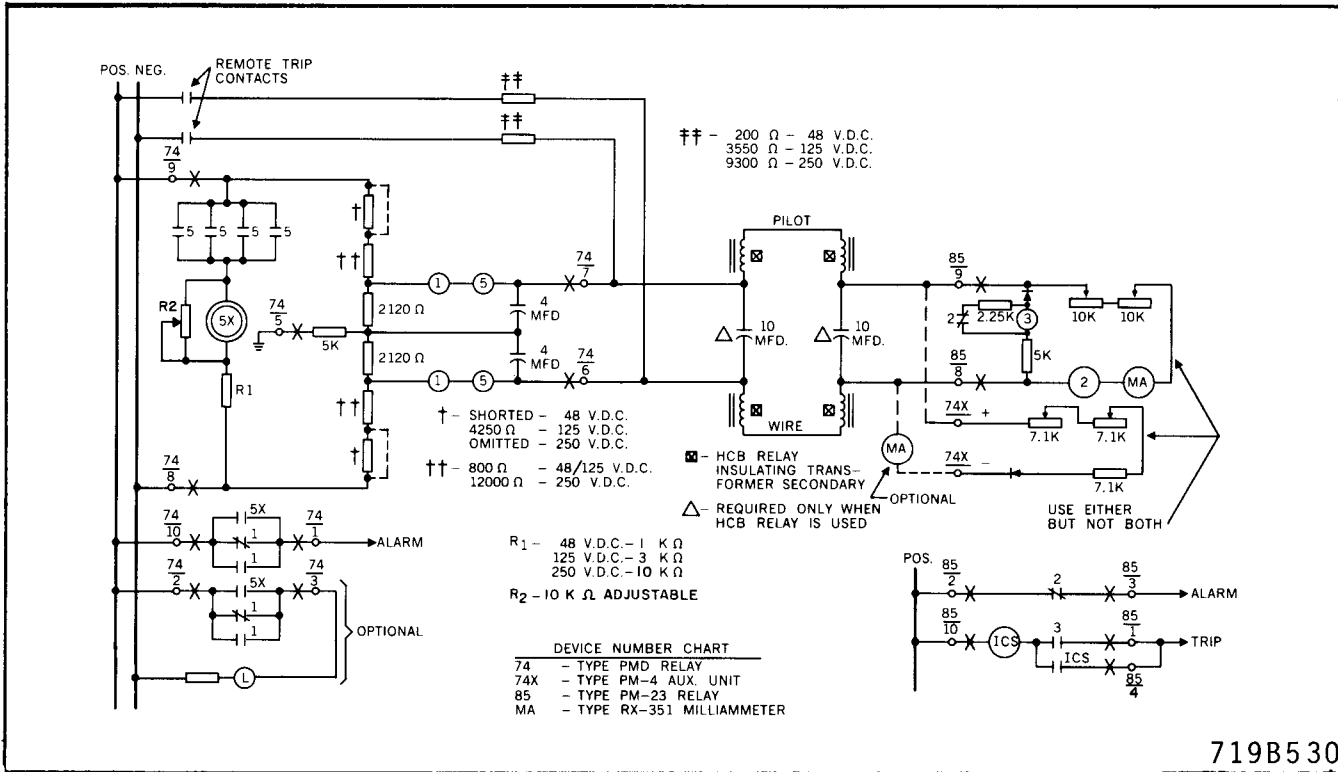

Fig. 25. External schematic of the type PMD relay with type PM-23 or PM-4 relay - Two terminal lines.

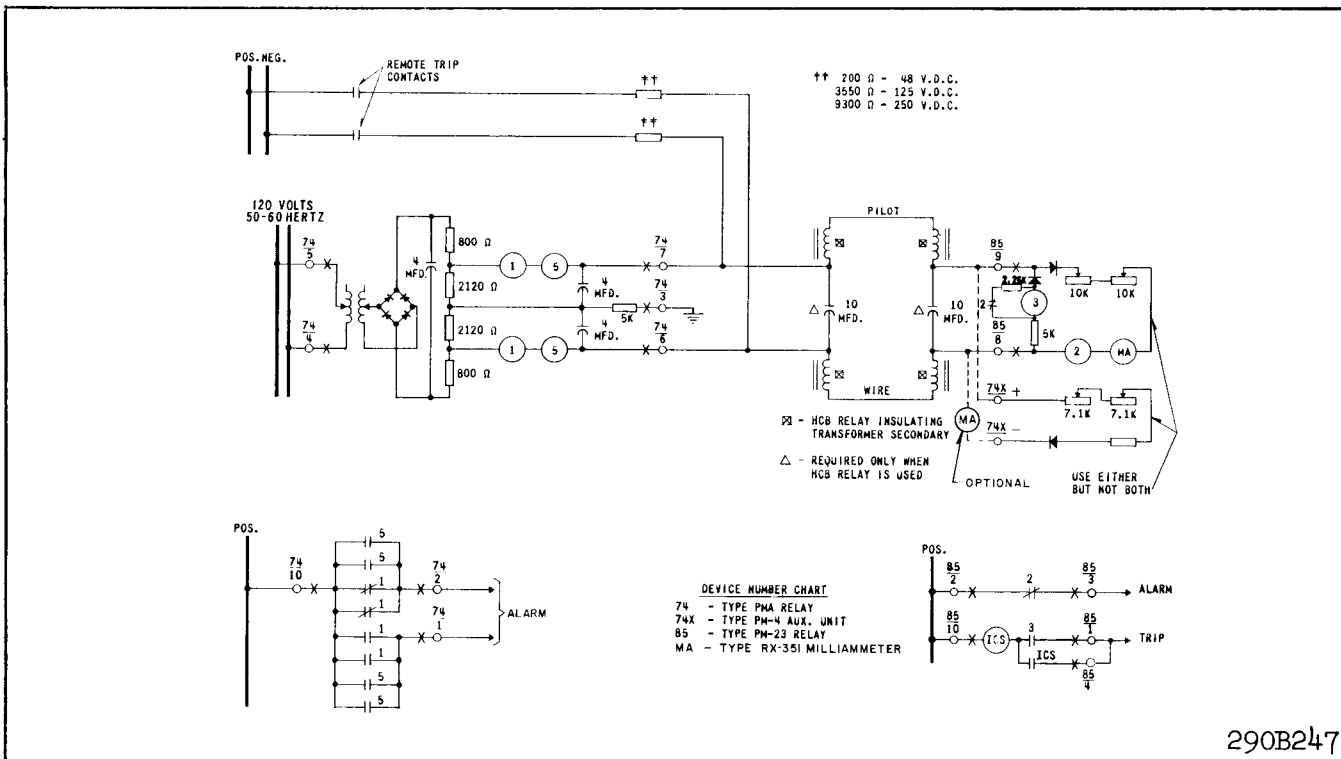

Fig. 26. External schematic of the type PMA relay with type PM-23 or PM-4 relay - Two terminal lines.

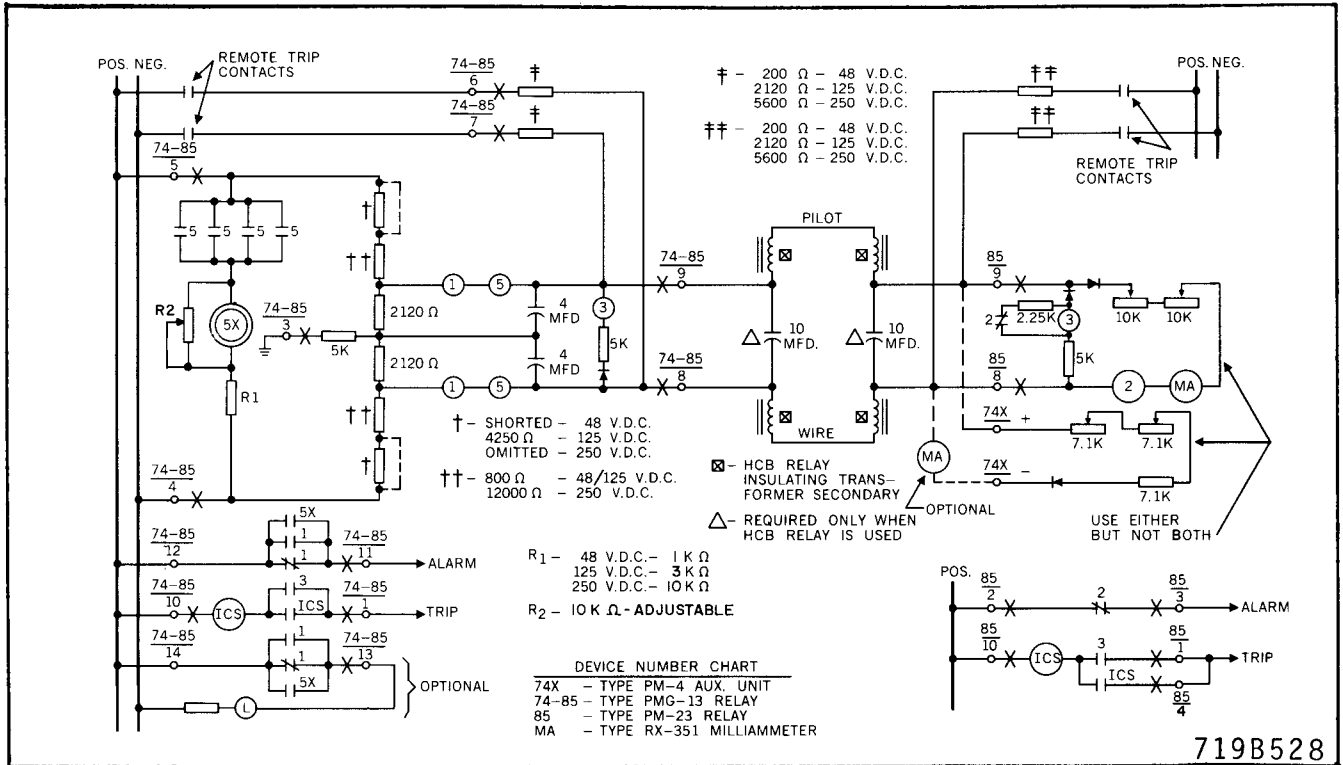

Fig. 27. External schematic of the DC type PMG-13 relay with type PM-23 or PM-4 relay - Two terminal lines.

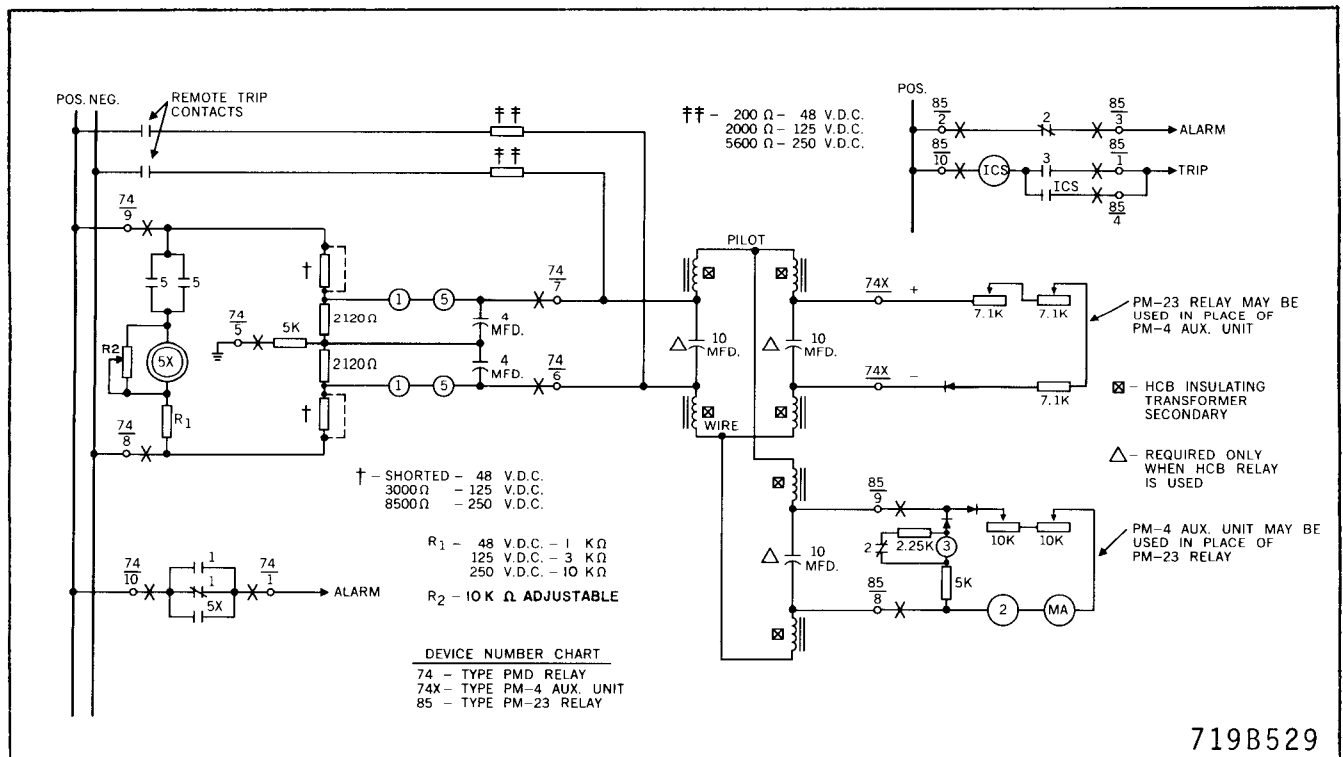

Fig. 28. External schematic of the type PMD relay with type PM-23 and PM-4 relays - Three terminal lines.

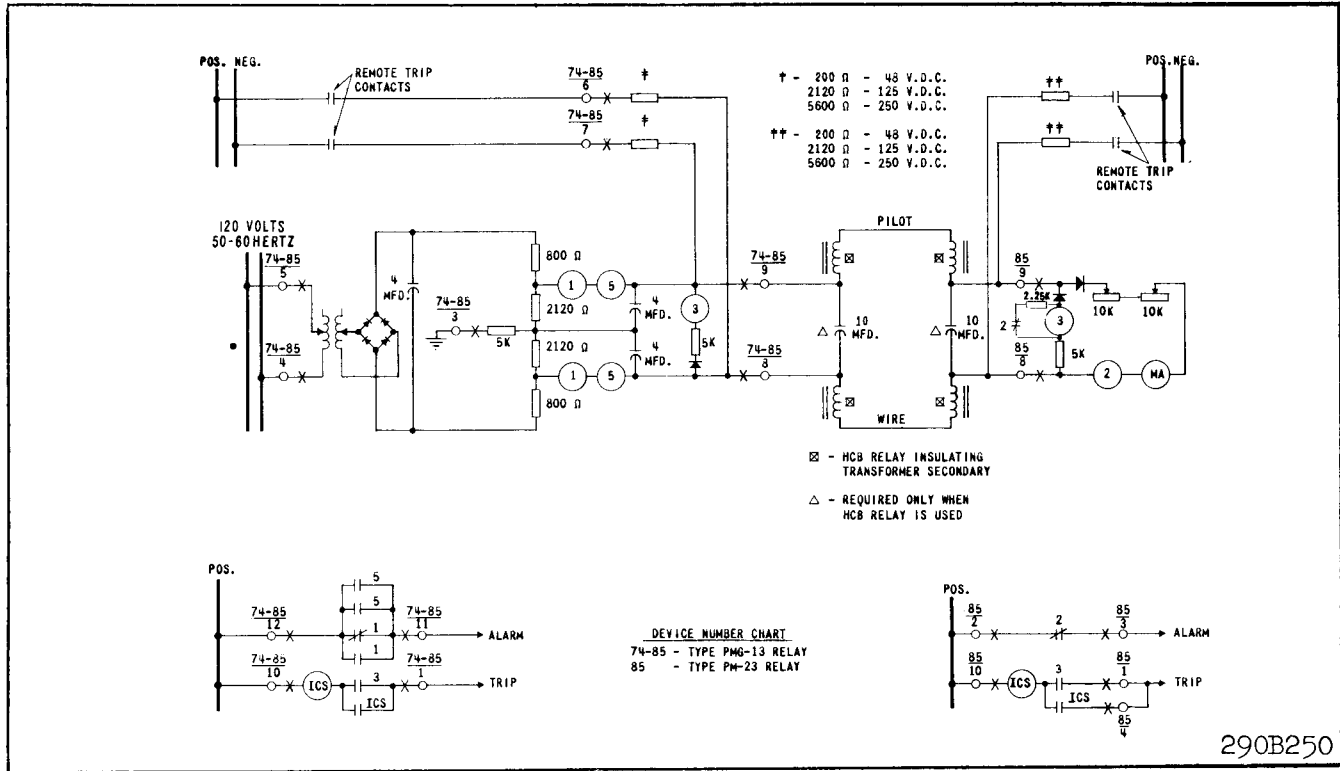

Fig. 29. External schematic of the AC type PMG-13 with type PM-23 relay - Two terminal lines.

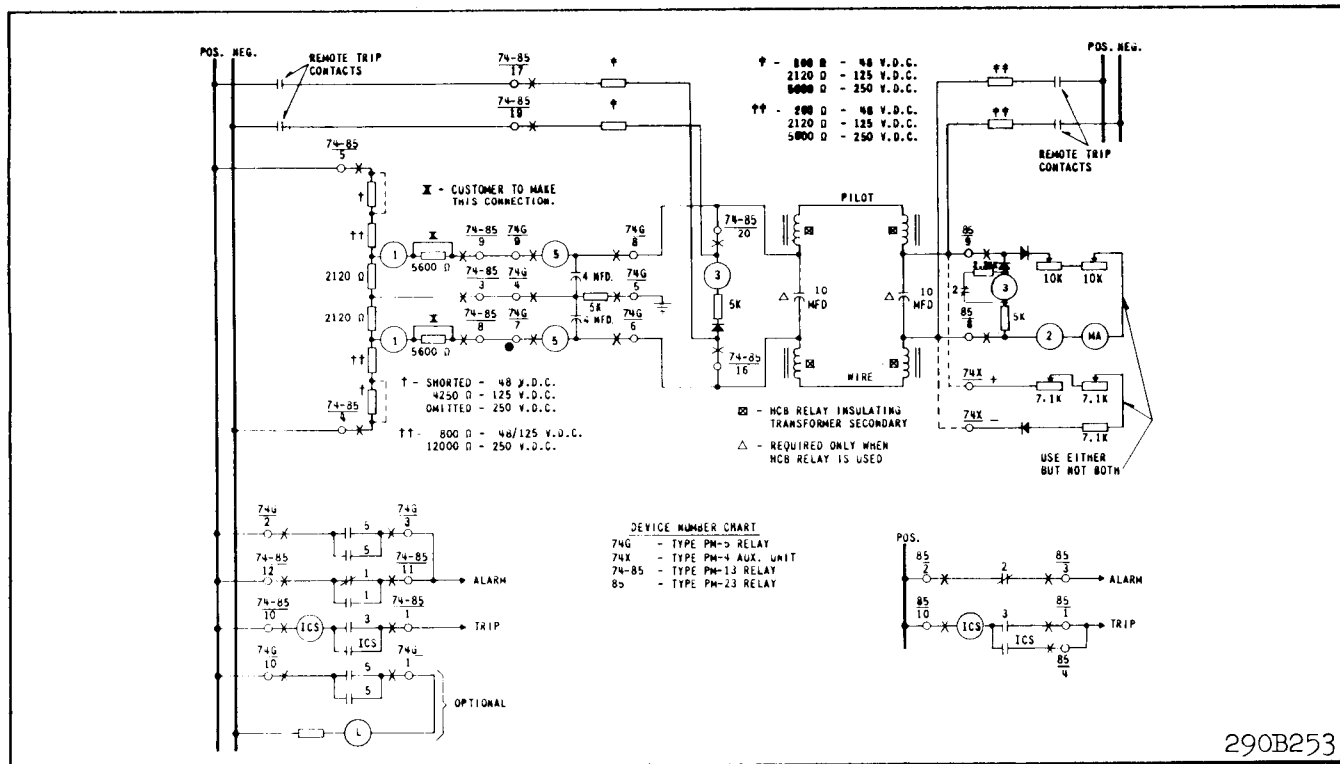

Fig. 30. External schematic of the DC type PM-13 and PM-5 relay with type PM-23 or PM-4 relay - Two terminal lines.

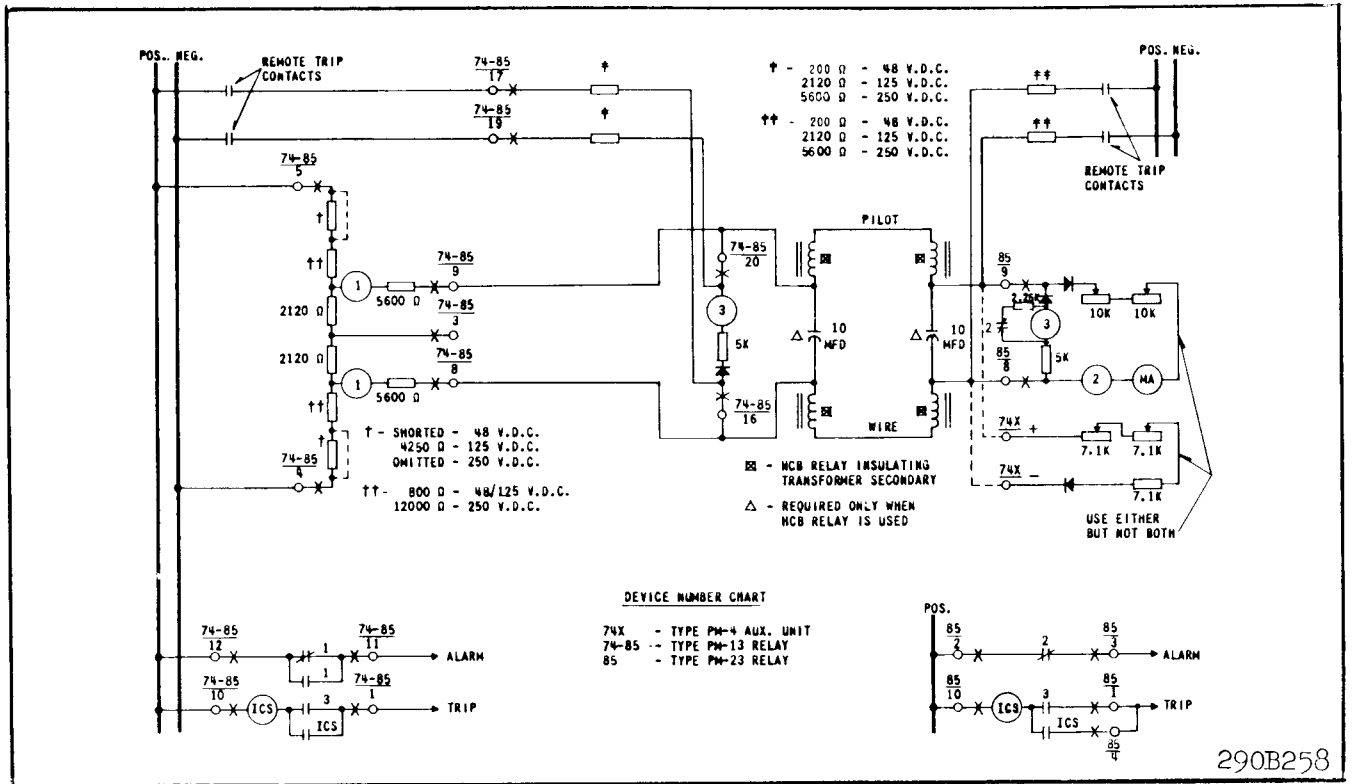
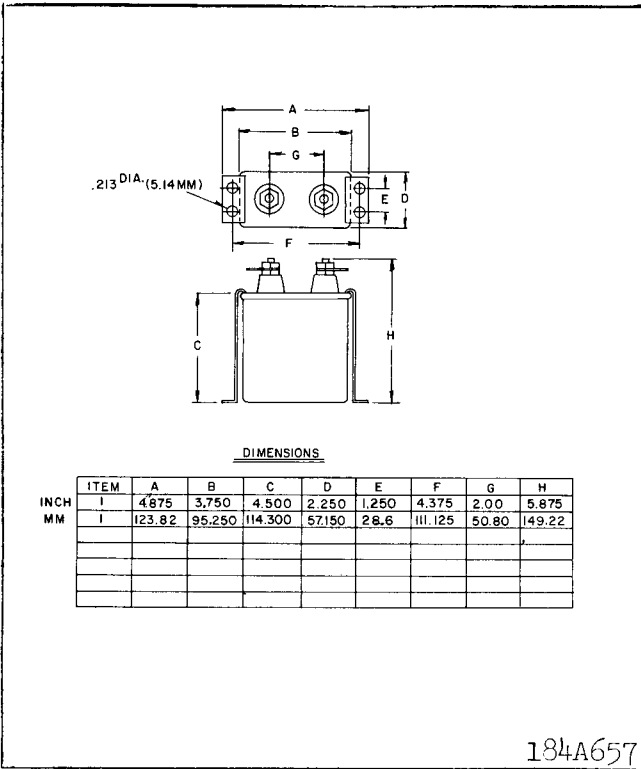
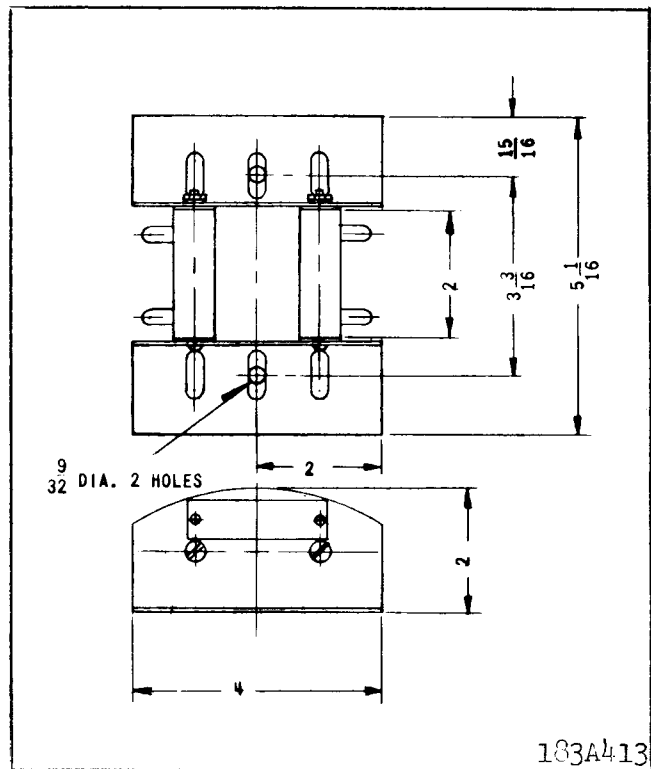

Fig. 31. External schematic of the DC type PM-13 relay with type PM-23 or PM-4 relay – Two terminal lines.



184A657

Fig. 32. Outline and Drilling Plan for 10 mfd. capacitor – For reference only.



183A413

Fig. 33. Outline and Drilling Plan for External Remote trip Resistor Assembly.

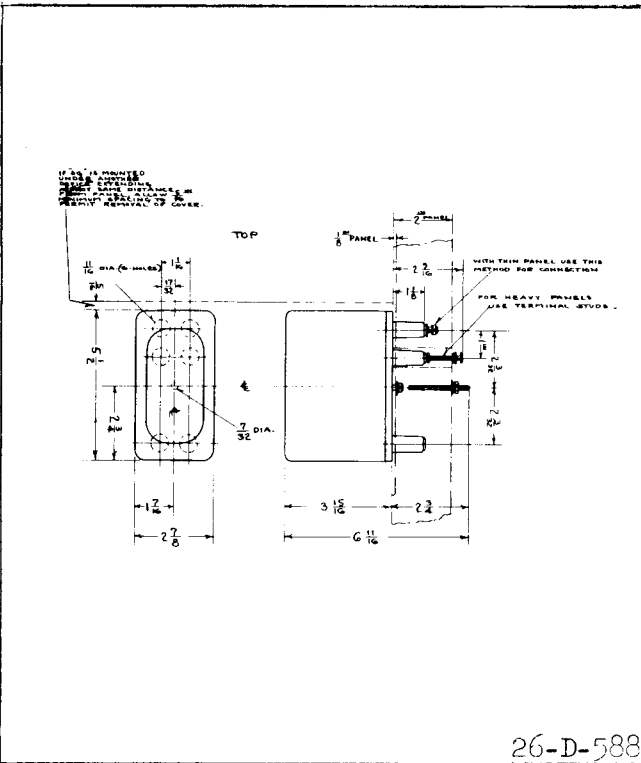

26-D-588

Fig. 34. Outline and Drilling Plan for the type PM-4 Auxiliary unit in the projection molded case.

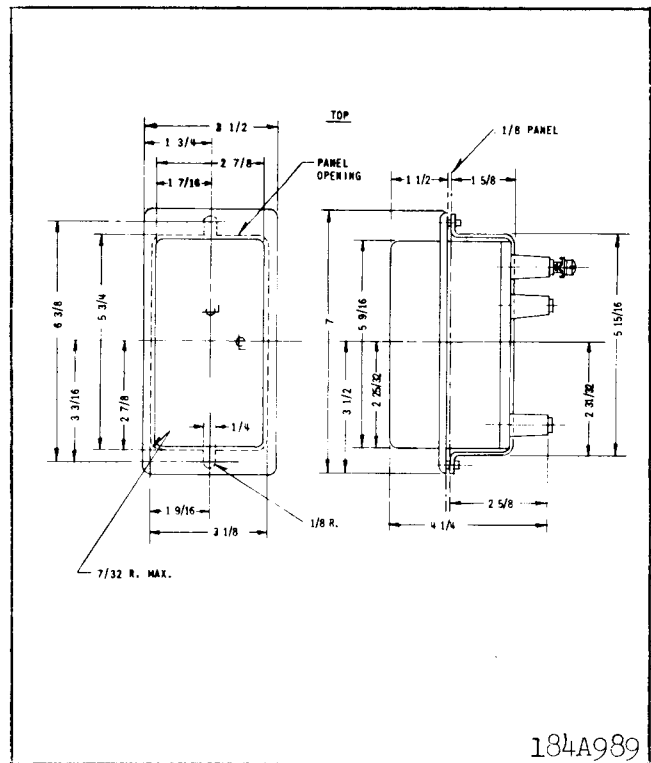

184A989

Fig. 35. Outline and Drilling Plan for the type PM-4 Auxiliary unit in the Semi-Flush molded case.

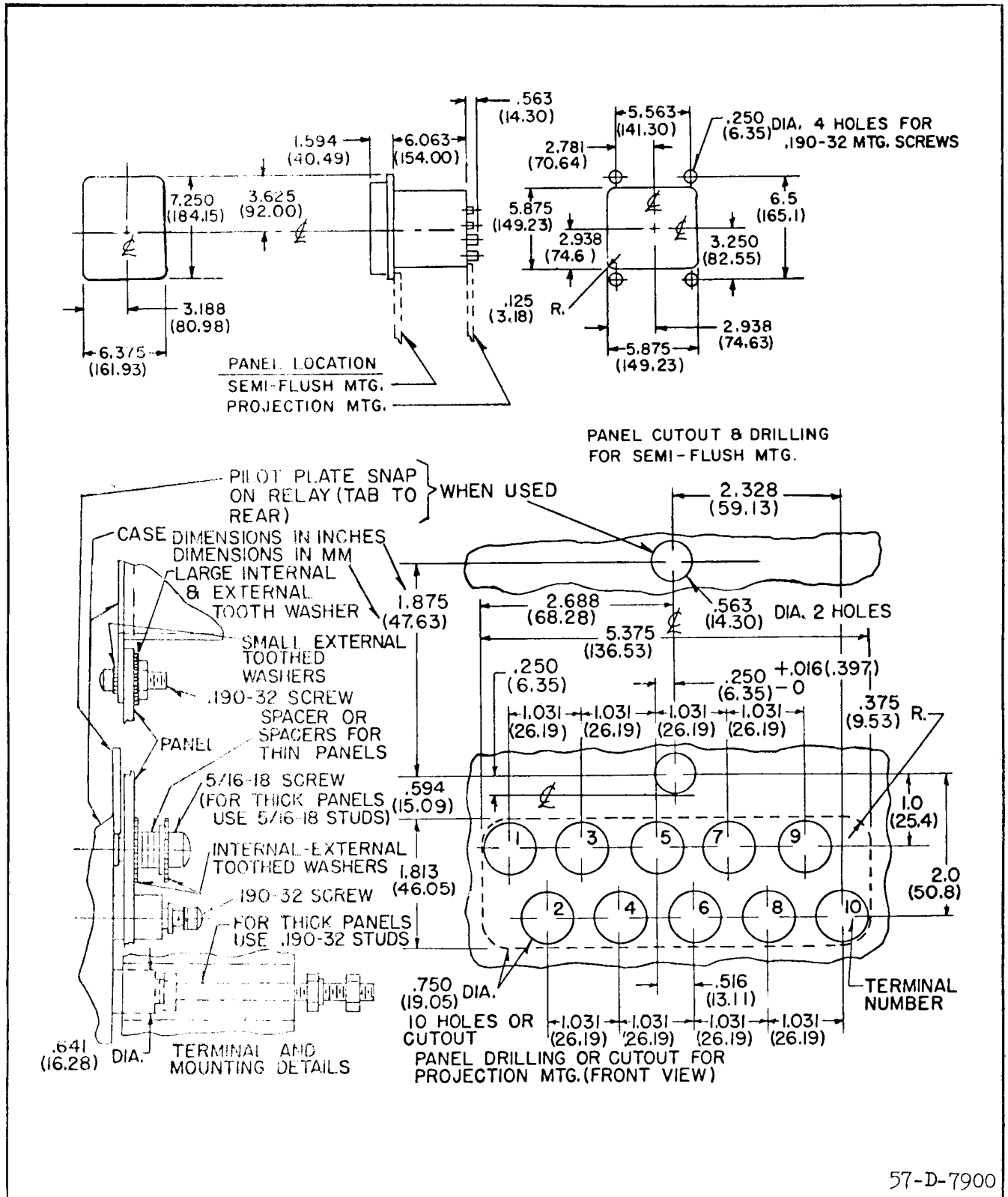

Fig. 36. Outline and Drilling Plan for the type PM-3, PM-5, & PMD-1 Relays in the type FT 11 case.

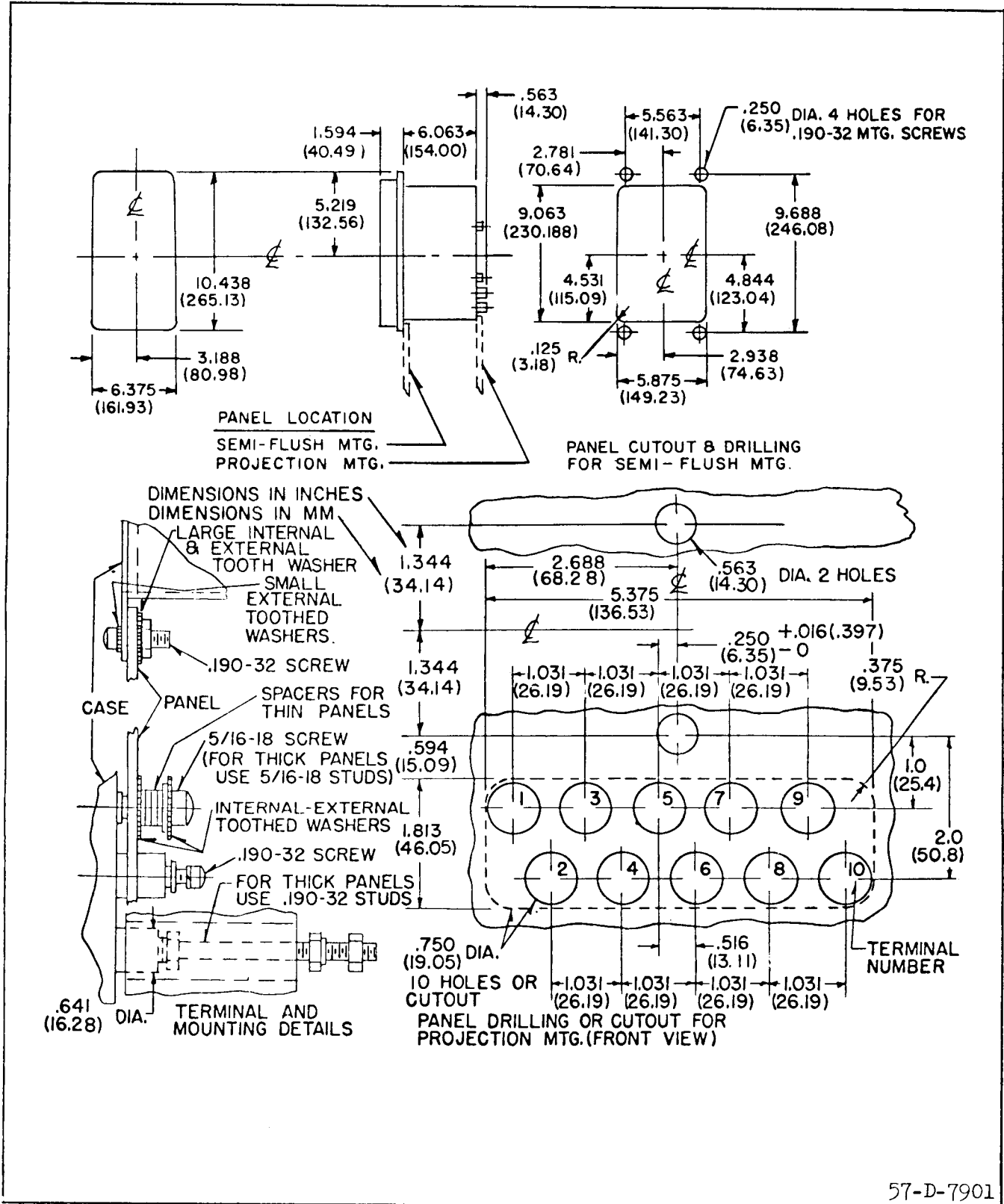

Fig. 37. Outline and Drilling Plan for the type PM-2, PM-23, PMA-1 and PMD relays in the type FT 21 case.

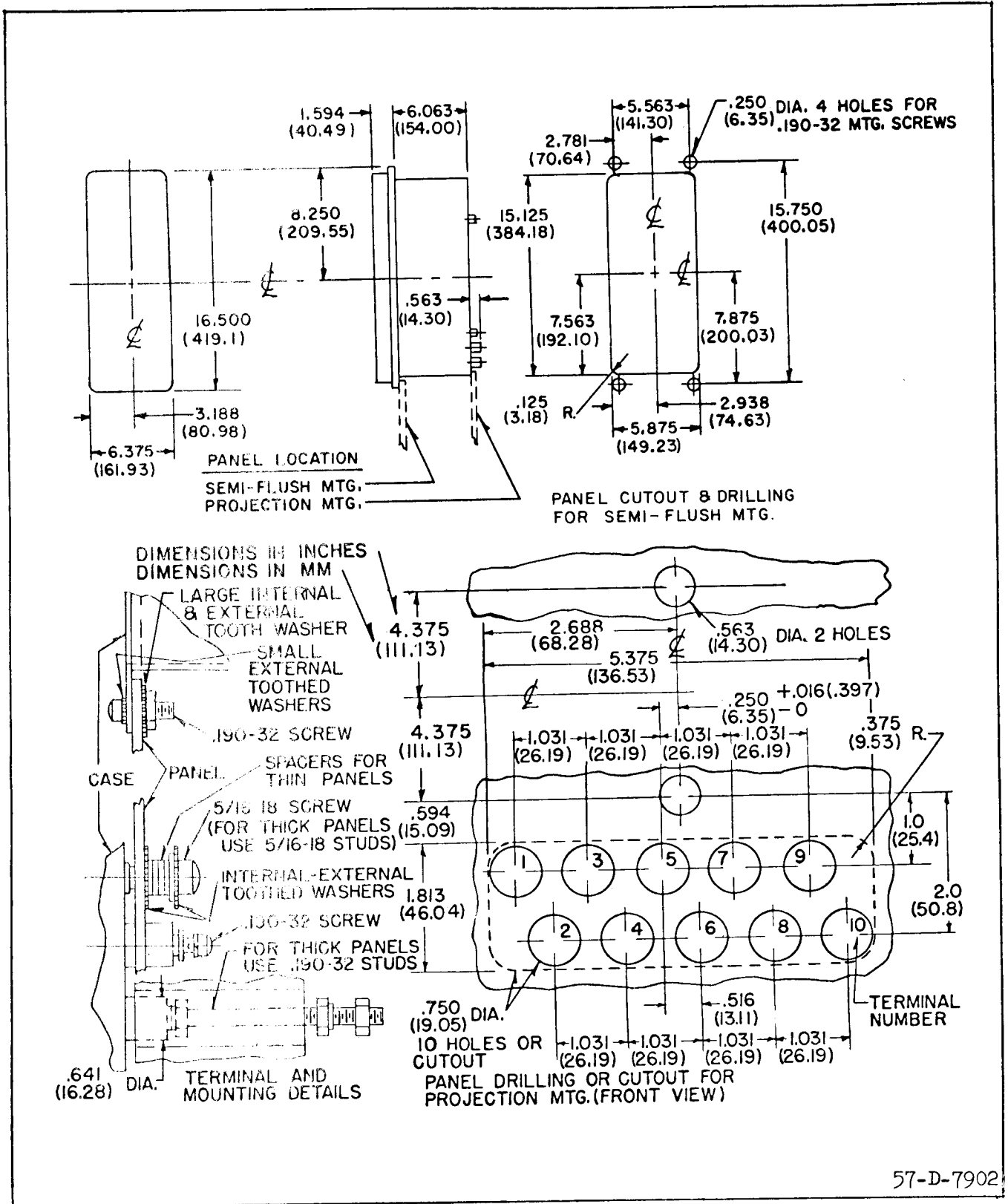

Fig. 38. Outline and Drilling Plan for the type PMA relay in the type FT 31 case.

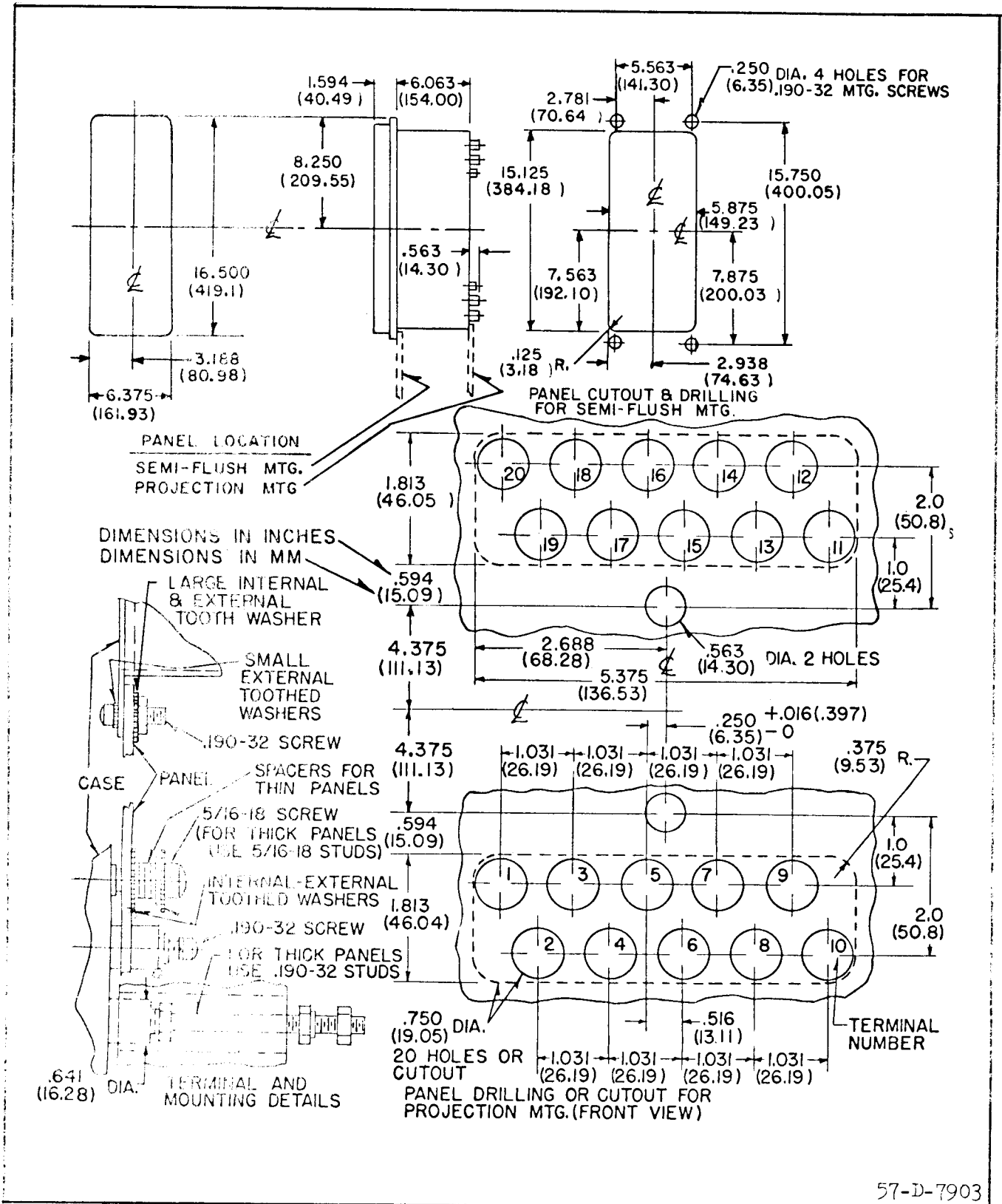
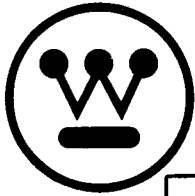

Fig. 39. Outline and Drilling Plan for the type PM-13 and PMG-13 relays in the type FT 32 case.



INSTALLATION • OPERATION • MAINTENANCE INSTRUCTIONS

TYPE PM LINE OF RELAYS FOR PILOT-WIRE MONITORING AND TRANSFERRED TRIPPING

CAUTION Before putting protective relays into service, remove all blocking which may have been inserted for the purpose of securing parts during shipment, make sure that all moving parts operate freely, inspect the contacts to see that they are clean and close properly, and operate the relay to check the settings and electrical connections.

APPLICATION

Type PM Monitoring Relays provide continuous monitoring of a pilot-wire circuit to detect open circuits, short circuits, grounds, and wire reversal. In addition, transferred tripping can be effected where the PM-3, PM-13, PMG-13 or PM-23 relays are used. Table I illustrates the functions available with each relay. A 10 mfd. capacitor is supplied with each PM relay. This capacitor provides an a-c path between the two halves of the insulating transformer secondary windings as shown in Figs. 25 through 31.

Each circuit requires the following:

At one end to introduce monitoring current

One of the following:

For a-c Supply

For d-c Supply

PMA

PMD

PMA-1.

PMD-1

PM-13 or PMG-13 (a.c.)

PM-13 or PMG-13 (d.c.)

At the other end to receive monitoring current (two-terminal line)

One PM-23 or PM-2 or PM-4

At the other ends to receive monitoring current (three-terminal line)

One PM-23 or one PM-4 or one PM-2 for each remote terminal.

CONSTRUCTION

PM relays consist of the following:

PMA

PMA-1

1-Polar Alarm Unit (1)

1-Polar Alarm Unit

1-Polar Ground Unit (5)
1-Tapped Transformer
1-Full-Wave Rectifier
3-4 mfd. Capacitors
1-Set of Potential
Dividing Resistors

PMD

1-Polar Alarm Unit (1)
1-Polar Ground Unit (5)
2-4 mfd. Capacitors
1-Set of Potential
Divider Resistors

PMG-13

1-Polar Alarm Unit (1)
1-Polar Ground Unit (5)
1-Polar Trip Unit (3)
1-Indicating Contactor
Switch
1-Set of Potential
Divider Resistors
1-Tapped Transformer
(A.C. Relay only)
1-Full-Wave Rectifier
(A.C. Relay only)
1-Blocking Rectifier
2-Remote Trip Resistors
3-4 mfd. Capacitors
(A-C Relay)
2-4 mfd. Capacitors
(D-C Relay)

PM-23

1-Polar Alarm Unit (2)
1-Polar Trip Unit (3)
1-Indicating Contactor
Switch (ICS)
1-Milliammeter, 5.0 ma.
1-Set of Adjustable and
Fixed Resistors
2-Blocking Rectifiers

1-Tapped Transformer
1-Full-Wave Rectifier
1-4 mfd. Capacitor
1-Set of Potential
Dividing Resistors

PMD-1

1-Polar Alarm Unit
1-Set of Potential
Divider Resistors

PM-13

1-Polar Alarm Unit (1)
1-Polar Trip Unit (3)
1-Indicating Contactor
Switch
1-Set of Potential
Divider Resistors
1-Tapped Transformer
(A.C. Relay only)
1-Full-Wave Rectifier
(A.C. Relay only)
1-Blocking Rectifier
2-Remote Trip Resistor
1-4 mfd. Capacitor

PM-2

1-Polar Alarm Unit (2)
1-Milliammeter, 5.0 ma.
1-Set of Adjustable
Resistors
1-Blocking Rectifier

TYPE PM MONITORING RELAYS

PM-3

- 1-Polar Trip Unit (3)
- 1-Resistor
- 1-Blocking Rectifier
- 1-Indicating Contactor Switch (ICS)

PM-4

- 1-Blocking Rectifier
- 1-Set of Adjustable & Fixed Resistors

PM-5

- 1-Polar Ground Unit (5)
- 2-4 mfd. Capacitors
- 1-Fixed Resistor

TABLE I

FUNCTION	PMA & PMD	PMA-1 & PMD-1	PM-13	PMG-13	PM-23	PM-2	PM-3	PM-4	PM-5
Monitoring Current Source	X	X	X	X					
Receives Monitoring Current					X	X		X	
Trouble Alarm	X	X	X	X	X	X			X
Transmits Trip Signal	X †	X †	X	X	X †	X †	X †	X †	
Receives Trip Signal			X	X	X		X		
Sensitive Ground Detection	X			X					X
Measures Monitoring Current					X	X			

† With External Resistors

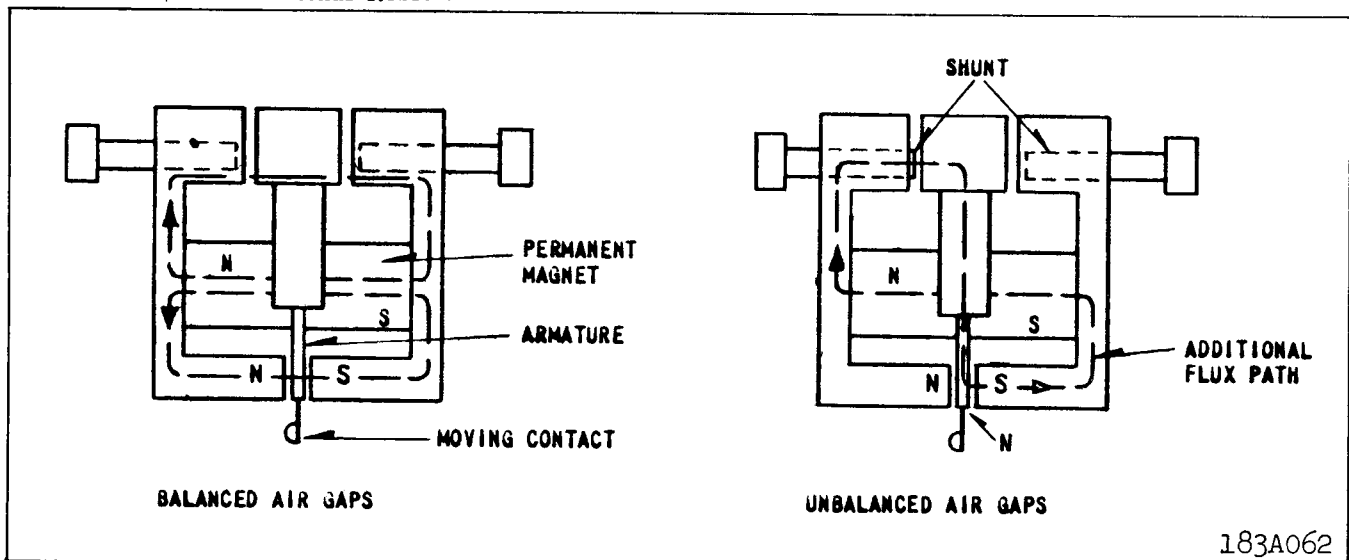

Fig. 1. Polar Unit Permanent Magnet Flux Paths.

Polar Unit

The polar unit consists of a rectangular shaped magnetic frame, an electromagnet, a permanent magnet, and an armature. The poles of the crescent shaped permanent magnet bridge the magnet frame. The magnetic frame consists of three pieces joined in the rear with two brass rods and silver solder. These non-magnetic joints represent air gaps, which are bridged by two adjustable magnetic shunts. The winding or windings are wound around a magnetic core. The armature is fastened to this core and is free to move in the front air gap. The moving contact is connected to the free end of a leaf spring, which, in turn, is fastened to the armature.

Indicating Contactor Switch

The d-c indicating contactor switch is a small clapper type device. A magnetic armature, to which leaf-spring mounted contacts are attached, is attracted to the magnetic core upon energization of the switch. When the switch closes, the moving contacts bridge two stationary contacts, completing the trip circuit. Also during this operation two fingers on the armature deflect a spring located on the front of the switch, which allows the operation indicator target to drop. The target is reset from the outside of the case by a push rod located at the bottom of the cover.

The front spring, in addition to holding the target, provides restraint for the armature and thus controls the pickup value of the switch.

PMD & PMG13 with Tel. Relay: In the relays type PMD and PMG13 where they are energized with DC power supply, the ground polar unit (#5) could momentarily close its contact (for about 10 m.s.) if either positive or negative supply is grounded. To eliminate this momentary operation, a telephone relay with a nominal operating time of 25 m.s. was connected in series with contact of the "5" unit, and the contact of the telephone relay is used as an overall contact output of the "5" unit. This type of relay should be used where the DC power supply is subjected to short to the ground.

OPERATION

Pilot Wire Monitoring

- ⊛ Monitoring current is introduced into the pilot wire as shown in the external schematics, figures 25 to 31, by the monitoring current source. External schematics showing other combinations are available on request. A nominal 20 volts is impressed across the 10 mfd. capacitor at the left-hand line terminal
- ⊛ in Figures 25 to 31. This voltage produces a current circulating through one winding of the HCB insulating transformer, one pilot wire, the PM-23, PM-2, or PM-4,

and back through the other pilot wire and the other winding of HCB insulating transformer.

Adjustment of the resistors of the PM-23, PM-2 or PM-4 relay at the other end of the pilot wire provides a normal one-milliampere d-c circulating current. In the case of three-terminal lines, the monitoring source relay output current is 2 ma. in order to provide each receiving end relay with 1 ma. The alarm unit of the monitoring current source relay is adjusted to float between the high and low current contacts with normal monitoring current. The PM-23, receiving-end alarm relay, is adjusted to float between the low-current alarm contact and a contact stop with 1 ma. flowing.

Short Circuits

A complete or partial short circuit on the pilot wires increases the current in the current-source relay, causing the high-current alarm contacts to close. The resulting current decrease in the PM-23 relay closes the alarm contact. Short circuits of 5000 ohms or less will be detected.

Open Circuits

Current decreases to zero in all relays. Low-current alarm contact of the current source relay closes. Alarm contact of PM-23 relay closes.

Reversed Wires

On applications using the PM-23 relay, current increases in the sending end relay to close the high-current alarm contacts. Current drops to zero in the PM-23 relay monitoring coil to close the low-current alarm contacts.

If the pilot wire should be opened, the low-current contacts of the (2) unit will close. If the pilot wire is then reconnected with reversed connections, the (2) unit low-current contacts will remain closed. The capacitor at the sending end discharges through the pilot wire and the trip unit (3) circuit when the pilot wire is connected reversed. This would momentarily operate the trip unit (3) contact which would cause an incorrect trip; however, this is prevented by the (2) unit low-current contacts which connect a 2.25K resistor across the trip unit (3) coil. The 2.25K resistor remains connected across the trip-unit (3) coil until the pilot wire is connected properly.

The current decreases in both sending and receiving end relays when the PM-2, or PM-4 relays are used. Low current alarm contacts close.

Grounds

The voltage-divider circuit of the PMA, PMD, and PMG-13 source relays has its midpoint grounded through a current-limiting resistor. Thus, a pilot-wire ground will cause an increase in current in one coil

TYPE PM MONITORING RELAYS

circuit, and a decrease in the other one. This unbalance in the current flowing through the two windings (5) of the ground alarm relay unit will cause it to close one of its contacts (depending on which pilot wire is grounded) to give an alarm. Grounds of 10,000 ohms or less will be detected.

For adding the sensitive ground detection where PMA-1, PMD-1, or PM-13 relays have been installed, the PM-5 relay can be added to the circuitry, as shown in figure 30. This relay also has a 10,000-ohm ground sensitivity.

Transferred Tripping

Breakers located at the PMG-13 or PM-13 and PM-3 or PM-23 stations can be tripped by the application of a d-c voltage to the pilot wires at remote locations, as shown in figures 25 to 31. Transferred tripping can be effected from any location by applying 48 volts d-c (through dropping resistors when required) to the pilot wire with polarity opposite to that of the monitoring voltage. When tripping the PM-23, the current is increased above 2.0 ma, in reverse direction, to close the trip contact. When tripping the PMG-13 or PM-13, the reversed d.c. voltage operates the trip unit (3).

See Tables II and III for tripping resistor values. Nominal tripping currents is 5ma. at all rated voltages.

Polar Unit

Polar unit flux paths are shown in figure 1. With balanced air gaps, permanent magnet flux flows in two paths, one through the front, and one through the rear gaps. This flux produces north and south poles, as shown. By turning the left shunt in, some of the flux is forced through the armature, making it a north pole. Thus, reducing the left hand rear gap will produce a force tending to pull the armature to the right. Similarly, reducing the right hand gap will make the armature a south pole and produce a force tending to pull the armature to the left.

The alarm unit contacts of the sending and receiving end relays are biased to move to the left when the relay is deenergized. The PMG-13 or PM-13 and PM-23 trip unit contact is biased to move to the left when the relay is deenergized. The PM-5 is adjusted so that the moving contact floats when the relay is deenergized.

CHARACTERISTICS

Nominal Calibration Values

Nominal current values to close contacts are listed in Tables IV and V.

Voltage Ratings

Supply voltage ratings of the monitoring source relays to obtain continuous monitoring current are as follows:

DC - 48, 125, and 250 volts

AC - 120 volts, 60 hertz (Primary taps 100, 110, 120 & 130)

Voltage impressed on the pilot wire is a nominal 20 volts for monitoring, and 48 volts for tripping.

Supply voltage ratings to obtain remote tripping are: 48, 125, and 250 volts d-c.

Coil Resistance (each winding)

Alarm coil (1)	
two terminal line	1050-1250 ohms
three terminal line	700-900 ohms
Alarm coil (2)	2200-2600 ohms
Trip coil (3)	1800-2200 ohms
Ground Alarm coil (5)	5200-5800 ohms

PM-4 and PM-23 Resistance

Nominal PM-4 and PM-23 total resistance when adjusted for service is 20,000 ohms less pilot wire loop resistance at 1 ma.

PMA, PMA-1 and AC PMG-13, PM-13 Burden

0.5 VA at tap voltage	-	2-terminal line relay
1.0 VA at tap voltage	-	3-terminal line relay

Rectifiers

Approximate forward resistance - 560 ohms at 1 ma
300 ohms at 2 ma

Rating

Continuous forward	
current - amperes	- 1
Continuous back	
voltage - rms volts	- 200

Remote Tripping

Remote trip resistors are listed in Table II and III for 48, 125, and 250 volts d-c.

The relays have sufficient thermal capacity to withstand 20 MA d-c continuously when remote tripping. Nominal trip currents in the tripping relays are 5.0 MA d-c with 48, 125, and 250 volts d-c supply and a 2000-ohm pilot wire.

TABLE II

PMA, PMA-1, PMD, AND PMD-1 APPLICATIONS
EXTERNAL RESISTORS FOR D.C. REMOTE TRIPPING
(2 REQUIRED PER STATION)

# LINE TERMINALS	D.C. VOLTAGE	STATION A PMA or PMA-1	STATION A PMD or PMD-1	STATION B PM-2 & PM-3 or PM-23 or PM-4	STATION C PM-2 & PM-3 or PM-23 or PM-4	TO OPERATE
2	48	200	200	—	—	PM-23 or PM-3
	125	3550	3550	—	—	"
	250	9300	9300	—	—	"
3	48	200	200	—	—	"
	125	2000	2000	—	—	"
	250	5600	5600	—	—	"

TABLE IIIA

PMG-13 AND PM-13 (D.C. SUPPLY) APPLICATIONS
RESISTORS FOR D.C. REMOTE TRIPPING
(2 REQUIRED PER STATION)

# LINE TERMINALS	D.C. VOLTAGE	STATION A PMG-13 or PM-13	STATION B PM-2 & PM-3 or PM-23 or PM-4	STATION C PM-2 & PM-3 or PM-23 or PM-4	TO OPERATE
2	48	200 †	200	—	PMG-13 or PM-13 and PM-23 or PM-3
	125	2120 †	2120	—	"
	250	5600 †	5600	—	"
3	48	200 †	200	200	"
	125	1500 †	1500	1500	"
	250	4000 †	4000	4000	"

† Mounted in Relay

TABLE IIIB

PMG-13 AND PM-13 (A.C. SUPPLY) APPLICATIONS
(2 REQUIRED PER STATION)
RESISTORS FOR D.C. REMOTE TRIPPING

# LINE TERMINALS	D.C. VOLTAGE	STATION A PMG-13 or PM-13	STATION B PM-2 & PM-3 or PM-23 or PM-4	STATION C PM-2 & PM-3 or PM-23 or PM-4	TO OPERATE
2	48	200 †	200	—	PMG-13 or PM-13 and PM-23 or PM-3
	125	2120 †	2120	—	"
	250	5600 †	5600	—	"
3	48	200 †	200	200	"
	125	1500 †	1500	1500	"
	250	4000 †	4000	4000	"

† Mounted in Relay

TABLE IV

NOMINAL CALIBRATION VALUES - TWO TERMINAL LINES

<u>RELAY</u>	<u>LOW CURRENT ALARM</u> ¹	<u>HIGH CURRENT ALARM</u> ²	<u>TRIP</u>
PMA or PMA-1	0.7 ma	1.3 ma	-
PMD or PMD-1	0.7	1.3	-
PM-5 †	-	±0.3	-
PMG-13 or PM-13	0.7 ††	1.3 ††	14 V.
PM-23 or PM-2 & PM-3 †	0.7	-	14 V.

† Same relay as for three-terminal lines
 †† These are pilot-wire current values

1—Left-hand contacts, front view.
 2—Right-hand contacts, front view.

TABLE V

NOMINAL CALIBRATION VALUES - THREE TERMINAL LINES

<u>RELAY</u>	<u>LOW CURRENT ALARM</u>	<u>HIGH CURRENT ALARM</u>	<u>TRIP</u>
PMA or PMA-1	1.7 ma	2.3 ma	-
PMD or PMD-1	1.7	2.3	-
PM-5 †	-	±0.3	-
PMG-13 or PM-13	1.7 ††	2.3 ††	14 V.
PM-23 or PM-2 & PM-3 †	0.7	-	14 V.

† Same relay as for two-terminal lines
 †† These are pilot-wire current values

Trip Circuit

The main contacts will safely close 30 amperes at 250 volts d-c and the seal-in contacts of the indicating contactor switch will safely carry this current long enough to trip a circuit breaker.

The indicating contactor switch has two taps that provide a pickup setting of 0.2 or 2 amperes. To change taps requires connecting the lead located in front of the tap block to the desired setting by means of a screw connection.

Trip Circuit Constant

Indicating Contactor Switch (ICS)

- 0.2 ampere tap 6.5 ohms d-c resistance
- 2.0 ampere tap 0.15 ohms d-c resistance

SETTING THE RELAY

Operating units of all relays are adjusted in the factory to the values listed in Tables IV and V to a tolerance of ±5%. No settings are required on these units.

For all 48/125-volt d.c. relays, connect jumpers across resistors as shown on the internal schematics.

PM-4, PM-2, and PM-23 Relays

Adjust the resistors in the PM-4, PM-2, or PM-23 relay or relays to a value of 1 MA d-c with the monitoring circuits connected for service. Use the milliammeter in the PM-23 for this purpose or use a portable milliammeter with a resistance of less than 200 ohms. Where it is not practical on three-terminal lines to adjust both receiving relays simultaneously, set one receiving relay for 18,000 ohms total resistance (including relay coil and resistors) by measurement prior to final adjustment of the other receiving relay. This procedure will minimize the change in monitoring current in the first relay to be adjusted when making the final adjustment of the second relay.

PMA, PMA-1, PMG-13 and PM-13 Relays

Select the transformer tap nearest to expected normal a-c supply voltage. The full wave rectifier is

connected to a secondary transformer tap. Where desired, the output voltage can be raised about 5% by reconnecting across the full secondary winding.

Indicating Contactor Switch

No setting is required on the ICS unit except the selection of the 0.2 or 2.0 ampere tap setting. This selection is made by connecting the lead located in front of the tap block to the desired setting by means of the connecting screw. When the relay energizes a type WL relay switch, or equivalent, use the 0.2 ampere tap.

INSTALLATION

The relays should be mounted on switchboard panels or their equivalent in a location free from dirt, moisture, excessive vibration, and heat. Mount the relay vertically by means of the four mounting holes on the flange for semi-flush mounting or by means of the rear mounting stud or studs for projection mounting. Either a mounting stud or the mounting screws may be utilized for grounding the relay. The electrical connections may be made directly to the terminals by means of screws for steel panel mounting or to the terminal studs furnished with the relay for thick panel mounting. The terminal studs may be easily removed or inserted by locking two nuts on the stud and then turning the proper nut with a wrench.

For detailed FT case information, refer to I.L. 41-076.

Where the potential to ground impressed on the relays can exceed 700 volts, a drainage reactor in conjunction with a KX-642 tube, or the reactor in conjunction with 700 volt carbon-block arresters, is recommended. For details, see Protection of Pilot-Wire Circuits, AIEE Committee Report, paper 58-1190, AIEE Transactions, 1959, Volume 78, Part III B pp. 205-212. Also, see AIEE Special Publication S-117, Applications and Protection of Pilot-Wire Circuits for Protective Relaying, July 1960.

ADJUSTMENTS AND MAINTENANCE

The proper adjustments to insure correct operation of this relay have been made at the factory and should not be disturbed after receipt by the customer. If the adjustments have been changed, the relay taken apart for repairs, or if it is desired to check the adjustments at regular maintenance periods, the instructions in the succeeding sections should be followed.

Acceptance Tests

The following tests are recommended when the relay is received from the factory. If the relay does not perform as specified below, the relay either is not properly calibrated or it contains a defect.

Indicating Contactor Switch (ICS)

Close the contact of the tripping unit and pass sufficient direct current through the trip circuit to close the contacts of the ICS unit. This value of current should not be greater than the particular ICS tap setting being used (0.2 or 2.0). The indicator target should drop freely.

PMA and PMA-1 Relays

Alarm Unit (1)

Set the primary tap on 120 volts. Connect a variable resistor of approximately 20,000 ohms in series with a low-range d-c milliammeter across terminals 6 and 7 with the instrument positive connected to terminal 7. Apply 120 volts at rated frequency to terminals 4 and 5. Adjust the 20,000-ohm resistor to obtain a current of one ma. d.c. For a three-terminal line relay, use a 10,000-ohm resistor and set the current to 2 ma. d.c. At this value, the moving contact of the alarm or monitoring relay unit (1) should float between the two sets of stationary contacts. In the PMA relay, the ground alarm unit (5) contact should also float. (This contact will also float when the relay is de-energized.) Increase and decrease the one or two-milliampere monitoring current to check the calibration values listed in Tables IV and V.

Ground Unit (5)

Reconnect the 20,000-ohm resistor. For the PMA relay only, short terminals 7 and 3. The contact of the ground alarm unit (5) should close to the right when the relay is energized. Remove the short, and connect it between terminals 6 and 3. The ground alarm unit (5) should close to the left. The action of the monitoring unit (1) contact is of no significance in this simulated pilot-wire ground test. To check the pickup current of the ground detector, first remove the 20,000-ohm resistor from terminals 6 and 7. Connect a 0-1 d.c. milliammeter in series with a variable resistor of about 50,000 ohms between terminals 3 and 6. The ground unit should close its left-hand contact at approximately 0.3 ma. d.c. With the milliammeter and resistor connected between terminals 3 and 7, the right-hand contact should close at 0.3 ma. d.c.

TYPE PM MONITORING RELAYS

PMD and PMD-1 Relays

Alarm and Ground Units

Connect an adjustable 20,000-ohm resistor (or 10,000-ohms for a 3-terminal relay) in series with a d-c milliammeter across terminals 6 and 7 with the instrument positive connected to terminal 7. Apply rated d-c voltage to terminals 8 and 9 with positive on terminal 9. Now check the PMD and PMD-1 relays, following the procedure given in the previous section for the PMA and PMA-1 relays, respectively. Note, however, that terminal 5 of the PMD relay corresponds to terminal 3 of the PMA relay.

PM-2, PM-3, and PM-23 Relays

Alarm Unit (2)

Apply a variable d-c voltage of approximately 20 volts to relay terminals 8 and 9 (terminal 9 positive) of the PM-2 or PM-23 relay. Adjust the voltage to obtain a reading of one ma. on the relay milliammeter. The monitoring polar unit (2) contacts should float. Reduce the current gradually. The monitoring alarm contacts should close at 0.7 ma. d.c. The tripping unit (3) of the PM-23 relay should not move during this test. The milliammeter has been adjusted to read 1 ma. $\pm 5\%$. As a result the pointer may not read zero for a zero current condition.

Tripping Unit (3)

To check the PM-3 relay or the tripping unit of the PM-23 relay, apply the variable d-c voltage in series with an external milliammeter to relay terminals 8 and 9 with terminal 8 positive for the PM-23 relay, or terminal 9 positive for the PM-3 relay. When checking the pickup of the PM-23 trip unit block open the alarm unit contacts (2) so as to remove the shunt resistor from around the trip coil (3).

The tripping relay unit (3) should pick up with positive action at 14 volts d.c. and should drop out at approximately 10 volts. The alarm unit of the PM-23 relay will not operate during this test.

PM-4 Relay

This device is simply a set of resistors and a diode to connect into the pilot-wire circuit to provide a path for the monitoring current. The resistors can be checked with an ohmmeter, and the diode can be checked either with an ohmmeter, or as explained in the section entitled "Rectifier Check" under "Routine Maintenance". If an ohmmeter is used, the difference in forward and reverse resistance readings obtained will be dependent on the current flowing through the diode.

PM-5 Relay

Apply 5 volts d.c. in series with a 0-1 d.c. milliammeter and a 20,000-ohm variable resistor to terminals 6 and 7 with positive on terminal 6. The left-hand contact should close at approximately 0.3 ma. Now apply the same circuit to terminals 8 and 9 with positive on terminal 9. The right-hand contact should close at approximately 0.3 ma.

PM 13 Relays - A.C. and D.C.

Alarm Unit (1)

Connect a variable 20,000-ohm resistor (10,000 ohms for a 3-terminal-line relay) in series with a d-c milliammeter across terminals 8 and 9 with the instrument positive on terminal 9. For the a-c relay, set the primary tap on 120 volts. Now apply the rated supply voltage to terminals 4 and 5. This will be 48, 125, or 250 volts d.c., or 120 volts a.c. as indicated on the relay nameplate. Adjust the variable resistor to obtain a current of one ma. for a 2-terminal line relay, or 2 ma. for a 3-terminal relay. At this value, the moving contacts of the alarm or monitoring (1) relay unit (the upper polar unit) should float between the two sets of stationary contacts. Increase and decrease the one or 2 ma. monitoring current to check the calibration values listed in Tables IV and V.

Tripping Unit (3)

To check the operation of the tripping unit 3 (the lower polar unit), apply a d.c. potential across terminals 16 (positive) and 20 (negative). The tripping polar unit should pick up at 14 volts, and should drop out at approximately 10 volts. The resistance of the series dropping resistors for transferred tripping (listed in Tables III A and III B) can be checked with an ohmmeter. The circuit location of these resistors can readily be seen from the external schematic, Figure 27.

PMG-13 Relays - A.C. and D.C.

Alarm and Tripping Units

Follow the procedure given in the previous section for the a-c. and d-c. PM-13 relays.

Ground Unit (5)

Connect the 20,000-ohm (or 10,000-ohm) resistor and milliammeter across terminals 8 and 9. With rated voltage applied and one ma. (or 2 ma.) flowing, successively short circuit terminals 3 and 8, then 3 and 9. The ground alarm unit 5 (lower polar unit) should move first to the left, then to the right. To check the pickup current of the ground detector, first remove the 20,000-ohm resistor from terminals 8 and 9. Connect a 0-1 d.c. milliammeter in series

with a variable resistor of about 50,000 ohms between terminals 3 and 8. The left-hand contact should close at approximately 0.3 ma. d.c. With the milliammeter resistor connected, between terminals 3 and 9, the right-hand contact should close at 0.3 ma. d.c. The external schematic diagrams for these relays are shown in Figures 27 and 29.

Routine Maintenance

CAUTION - Do not make any performance check, calibration tests, or adjustments while the PM relays are energized or connected to the pilot wires, to prevent the possibility of inadvertently causing a break operation. The PM relays may be removed from service for testing, without jeopardizing HCB relay protection, providing that the connections between the 10-mfd capacitor and the HCB insulating transformer are not disturbed.

Contacts

All contacts should be periodically cleaned. A contact burnisher S#182A836H01 is recommended for this purpose. The use of abrasive material for cleaning contacts is not recommended because of the danger of embedding small particles in the face of the soft silver and thus impairing the contact.

Operational Check

In addition to cleaning contacts, it is recommended that an operational check be performed periodically by opening and short-circuiting the pilot wires, as well as grounding them at the relay terminals. **Note:** These pilot-wire faults should not be applied directly to the pilot wires when the HCB relays are in service. It is also recommended that the trip circuits of the PM relays be opened (where tripping is used), to prevent the possibility of inadvertently tripping the associated circuit breaker during testing. If the relays do not perform as expected, and diode failure is suspected, the diode tests described in the following section may be performed.

Rectifier (Diode) Check

If there is suspicion of a rectifier (diode) failure, apply 30 volts d.c. reverse voltage (positive on arrowhead) through a 300-ohm resistance to the diode. Measure the voltage across the diode. If this voltage is not essentially 30 volts, the diode is short-circuited. Now apply 30 volts d.c. in the forward direction through the 300-ohm resistor, and measure the voltage across the resistor. If the voltage is not essentially 30 volts, the diode may have a high forward resistance. If the voltage is zero, the diode is open-circuited.

Calibration

If the relay has been dismantled or the calibration has been disturbed, use the following procedure for calibration.

With the permanent magnet removed, see that the moving armature floats in the central area of the air-gap between the poles of the polar unit frame. If necessary, loosen the core screw in the center rear of the unit and shift the core and contact assembly until the armature floats. (This can best be done with the polar unit removed from the relay.) Then retighten the core screw and replace the permanent magnet with the dimple (north pole) on the magnet to the left when viewed from the front.

Polar Units-General

The following mechanical adjustments are given as a guide, and some deviation from them may be necessary to obtain proper electrical calibration.

Magnetic Shunt Adjustment

The sensitivity of the polar unit is adjusted by means of two magnetic, screw-type shunts at the rear of the unit, as shown in Fig. 1. These shunt screws are held in proper adjustment by a flat strip spring across the back of the polar unit frame, so no locking screws are required. Looking at the relay, front view turning out the right-hand shunt to open the right-hand air gap decreases the amount of current required to close the right-hand contact. Conversely, drawing out the left-hand shunt increases the amount of current required to close the right-hand contact, or decreases the amount of current required to close the left-hand contact (with the proper direction of current flow). Also, if a relay trips to the right at the proper current, the dropout current can be raised by turning in the right-hand shunt. The two shunt-screw adjustments are not independent, however, and a certain amount of trimming adjustment of both shunt screws is generally necessary to obtain the desired pickup and dropout calibration.

In general, the farther out the two shunt screws are turned, the greater the toggle action will be, and as a result, the lower the dropout current. For the tripping units (3) of the PM-3, PM-13, and PM-23 relays, toggle action is desirable, with a dropout current around 75 percent of the pickup current. For the monitoring alarm relay units, toggle action is not desired. Instead, the armature is adjusted to float between the pole faces at a given current (1 or 2

TYPE PM MONITORING RELAYS

The following chart indicates the units present in each relay.

FUNCTION AND UNIT	PMA PMD	PMA-1 PMD-1	PM2	PM3	PM4	PM5	PM13	PMG13	PM23
Alarm for p.w. open, short or reversal (1) (2)	X	X	X				X	X	X
Transfer - Trip Unit (3)				X			X	X	X
Alarm for p.w. ground (5)	X					X		X	
D.C. Path for Monitoring Current					X				

ma.), and to move gradually toward the high or low-current alarm as the coil current is increased or decreased. Similarly, the floating adjustment of the armature of the ground alarm unit (5) requires that both shunt screws be turned in relatively far. Then the armature will move gradually to the left or right as the current through the two #5 coils is unbalanced.

The electrical calibration of the polar unit is also affected by the contact adjustment as this changes the position of the polar unit armature. Do not change the contact adjustment without rechecking the electrical calibration.

Contact Adjustment - All Relays

For all monitoring alarm units, designated (1) or (2), turn in all the stationary contact and contact stop screws until they just touch the moving contact. Advance the screws to hold the armature in the central portion of the magnetic air gap between the two pole faces. (The stationary contact screws have a round silver contact face; the stop screws do not have this silver facing.) Now back off all the contact and contact stop screws one full turn. This will give a total contact travel of 0.050 inch. When the relay is properly calibrated, some touch-up adjustment may be necessary so that double contacts will both close at the same current value. The contact gap between the floating moving contact and the right-hand or left-hand stationary contacts or contact stops will be approximately 0.025 inch when the relay is in operation.

For the tripping (3) units of the PM-3, PM-13, PMG-13, and PM-23 relays, adjust the contacts as described in the previous paragraph, except back off the contact and stop screws one-half turn each to

give a total moving contact travel of approximately 0.025 inch. In operation of the tripping unit, the moving contact will normally rest against the contact stop screws, and will pick up only for a transferred-tripping operation.

For the pilot-wire ground alarm unit (5) of the PMA, PMD, PM5, and PMG-13 relays, follow the same general procedure except back off both stationary contact screws two turns each. This will give a contact gap of 0.050 on each side of the moving contact when it is its normal central position.

Electrical Calibration - All Relays

In the following sections, the calibration instructions are given for the polar unit which performs a certain function, such as alarm (1) or (2), ground (5), or trip (3), rather than giving calibration instructions for each complete relay. In this way, considerable duplication of instructions has been eliminated.

Alarm Unit (1)

Connect the relay as described under Acceptance Tests for the particular relay involved. Screw the two magnetic shunts all the way in, then back them out five turns each. With the relay energized at rated voltage, set the monitoring current at 1.3 or 2.3 ma. d.c. for 2 or 3-terminal relay respectively, by adjusting the external resistor. If the relay does not close its right-hand contact, turn in the left shunt screw until the right-hand contact just closes. If the right-hand contact is closed at 1.3 ma., turn in the right shunt until a point is reached when the right-hand contact is just closed at 1.3 ma.

Now drop the current to 0.7 ma. and adjust the opposite shunt until the left-hand contact just closes

at 0.7 ma. d.c. At 1.0 ma. d.c., the moving contact should float half way between the two sets of stationary contacts with a 0.025-inch gap on each side. Recheck the high and low current calibration several times, touching up the shunt adjustments as required to obtain the desired calibration.

Polarization Check

For all the source relays, which are listed below, make the following additional calibration check:

- PMA PM-13 (a.c. and d.c.)
- PMA-1 PMG-13 (a.c. and d.c.)
- PMD
- PMD-1

After calibration as described in the previous sections, connect a 20,000 ohm resistor (or 10,000 ohms for 3-terminal applications) across the output terminals, and energize the relay at its rated supply voltage. With these connections, approximately one (or two) milliamperes d.c. will flow through the monitor relay coils and external resistor, thus representing normal operating conditions.

Now momentarily (one second or so) apply 48 volts d.c. directly to the pilot-wire terminals of the relay, as indicated in the following table.

Relay	Terminals for Momentary Application of 48 V. d.c.	
	POS.	NEG.
PMA, PMA-1 } PMD, PMD-1 }	6	7
PM-13 (a.c. or d.c.) } PMG-13 (a.c. or d.c.) }	8	9

After momentary application of the transfer-trip voltage as just explained, recheck the calibration of the monitoring alarm unit (1). If it has changed, make necessary trimming adjustments of the shunt screws until there is no change in calibrating of the alarm unit (1) after the transfer-trip voltage has been applied. The purpose of this test is to compensate for the small residual magnetism in the relay unit. The ground alarm unit (5) will not be affected by this test as the ampere-turns of the two windings cancel each other.

Alarm Unit (2)

For the alarm unit of the PM-2 or PM-23 relays, adjust the shunts so that the relay moving contact

floats at one ma. d.c., and closes the left-hand contact at 0.7 ma. d.c. The moving contact should float midway between the contact and contact stop at 1.0 ma. d.c. There is no high-current calibration for this relay unit.

Now apply 48 volts d.c. momentarily (one second or so) across the alarm unit coil-circuit terminals in a direction to operate the alarm relay. Then recheck the alarm unit calibration. If there is any change, touch up the shunt adjustments until there is no change in calibration after 48 v. d.c. has been applied.

Tripping Unit (3)

To calibrate the tripping unit of the PM-3, PM-13, PMG-13, or PM-23 relays apply a d.c. voltage as explained below, to the following relay terminals:

Relays	D.C. Voltage	
	Pos.	Neg.
PM-3	9	8
PM-13 (a.c. or d.c.)	16	20
PMG-13 (a.c. or d.c.)	8	9
PM-23	8	9

Momentarily (one second or so) apply 48 volts dc to the terminals shown in the chart. Then starting with both shunts all the way in, turn out the right-hand shunt screw until the relay closes its right-hand trip contact at 14 volts dc. Note: In the calibration of a PM-23 the alarm unit (2) contact must be blocked open so as not to affect the tripping unit pickup. (This will give approximately 2 ma. through the relay coil.) Now draw out the left-hand shunt until the relay resets with toggle action (not gradually) at not less than 10 volts dc. When the calibration is approximately correct, again apply 48 volts dc to the indicated terminals, then recheck the pickup and dropout voltage, making any necessary trimming adjustments of the shunts. When the relay is properly adjusted, the application of 48 volts dc will not change the pickup or dropout voltage points. The relay should trip and reset with toggle action in this application. This will require both shunt screws to be withdrawn farther than for floating action.

Ground Alarm Unit (5)

For the PM-5 relay, turn both shunt screws all the way in, then back them out five turns each. Pass a current of 0.3 ma. d.c. in terminal 6 and out terminal 7. Following the same general procedure as described previously in the section entitled "Alarm Unit (1)," adjust the shunt screws so that the left-hand contact closes at 0.3 ma. Now pass 0.3 ma. d.c.

TYPE PM MONITORING RELAYS

in terminal 9 and out terminal 8, and adjust for closing of the right-hand contact at 0.3 ma. Recheck both pickup points several times, and make trimming adjustments of both shunts as required to obtain contact closing at 0.3 ma. d.c. in each direction.

For the ground unit (5) of the PMA, PMD, and PMG-13 relays, connect a variable resistance of about 50,000 ohms in series with a 0-1 d.c. milliammeter between the terminals indicated in the following table:

Turn the shunts all the way in, then back them out five turns each. With the relay connected as shown in the left-hand column of the table, apply rated voltage to the relay and adjust the 50,000-ohm resistor for 0.3 ma. d.c. Now following the procedure in the previous paragraph for the PM-5 relay, adjust the shunts until the left-hand contact closes at 0.3 ma. d.c. Change the connections as indicated in the right-hand column, and adjust the opposite shunt until the right-hand contact closes. Recheck back and forth several times and make necessary trimming adjustments to obtain pickup at 0.3 ma. In each direction. The armature will move gradually as the

current is changed for this relay unit.

ICS Unit

Close the main relay tripping contact circuit with a jumper connected directly across the contact terminals of the polar unit. Pass sufficient direct current through the relay trip circuit to close the contacts of the ICS unit. This value of current should not be greater than the ICS tap setting being used (0.2 or 2.0). The indicator target should drop freely. The contact gap should be approximately 0.047 inch between the bridging moving contact and the adjustable stationary contacts. The bridging moving contact should touch both stationary contacts simultaneously.

RENEWAL PARTS

Repair work can be done most satisfactorily at the factory. However, interchangeable parts can be furnished to the customers who are equipped for doing repair work. When ordering parts, always give the complete nameplate data.

Ground Alarm (5) Calibration		
Relay	<u>Relay Terminals</u>	
	L.H. Contact Check	R.H. Contact Check
PMA	3 ⁺ and 6	3 and 7 ⁺
PMD	5 ⁺ and 6	5 and 7 ⁺
PMG-13	3 ⁺ and 8	3 and 9 ⁺

+ Milliammeter positive to this terminal

⊕ INDEX TO FIGURES

INTERNAL SCHEMATICS

FIG. NO.		PAGE NO.
1	Polar Unit Permanent Magnet Flux Paths	2
2	PMA Relay - AC supply - two terminal line	14
3	PMA-1 Relay - AC supply - two terminal line	14
4	PMA Relay - AC supply - three terminal line	14
5	PMA-1 Relay - AC supply - three terminal line	14
6	PMD Relay - DC supply - two terminal line	15
7	PMD-1 Relay - DC supply - two terminal line	15
8	PMD Relay - DC supply - three terminal line	15
9	PMD-1 Relay - DC supply - three terminal line	15
10	PM-2 relay in FT21 case	16
11	PM-3 relay in FT11 case	16
12	PM-4 relay (auxiliary unit)	16
13	PM-5 ground detector relay	16
14	PM-23 relay in FT21 case	17
15	PM-13 Relay - DC supply - two terminal line	17
16	PM-13 Relay - DC supply - three terminal line	17
17	PM-13 Relay - AC supply - two or three terminal line	17
18	PMG-13 Relay - DC supply - two terminal line	18
19	PMG-13 Relay - DC supply - three terminal line	18
20	PMG-13 Relay - AC supply - two or three terminal line	18
21	PMG-13 Relay - DC Supply - with Telephone Relay Output - two terminal line.....	19
22	PMG-13 Relay - DC Supply - with Telephone Relay Output - three terminal line.....	19
23	PMD Relay - DC Supply - with Telephone Relay Output - two terminal line	19
24	PMD Relay - DC Supply - with Telephone Relay Output - three terminal line.....	19

EXTERNAL SCHEMATICS

25	PMD relay with PM-23 or PM-4, two terminal line.....	20
26	PMA relay with PM-23 or PM-4, two terminal line.....	20
27	DC type PMG-23 with PM-23 or PM-4, two terminal line.....	21
28	PMD relay with PM-23 and PM-4, three terminal line.....	21
29	AC type PMG-13 relay with PM-23, two terminal line.....	22
30	DC type PM-13 and PM-5 with PM-23 or PM-4, two terminal line.....	22
31	DC type PM-13 relay with PM-23 or PM-4, two terminal line.....	23

OUTLINE & DRILLING PLANS

32	10 mfd. capacitor	24
33	Remote trip resistor	24
34	PM-4 projection molded case	24
35	PM-4 semi-flush molded case	24
36	PM-3, PM-5, & PMD-1 in FT11 case	25
37	PM-2, PM-23, PMA-1, & PMD in FT21 case	26
38	PMA in FT31 case	27
39	PM-13 and PMG-13 in FT32 case	28

TYPE PM MONITORING RELAYS

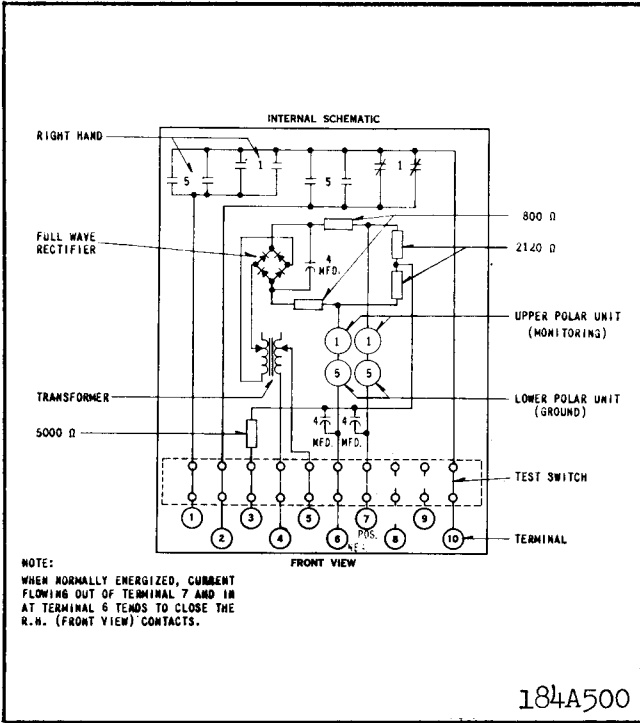

Fig. 2. Internal schematic of the type PMA relay in FT 31 case - 120 volt, 60 hertz supply - For two terminal lines.

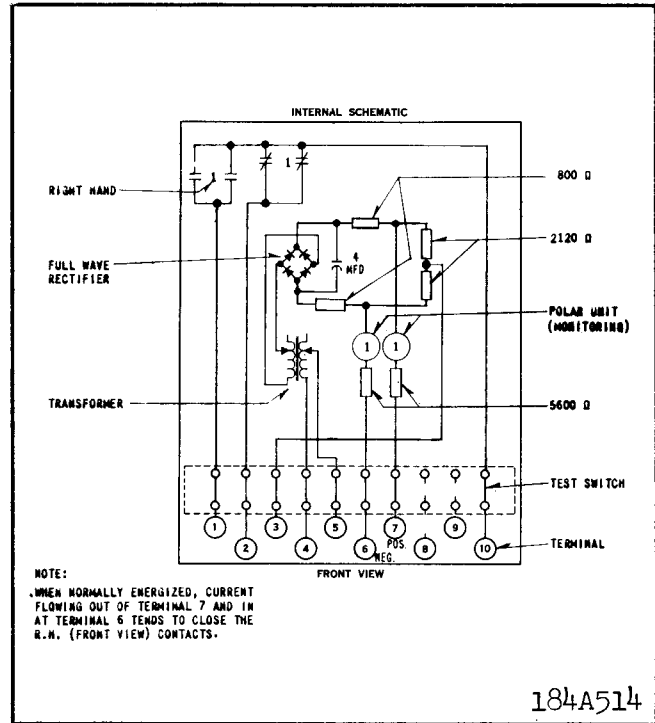

Fig. 3. Internal schematic of type PMA-1 relay in the FT 21 case - 120 volts, 60 hertz supply - For two terminal lines.

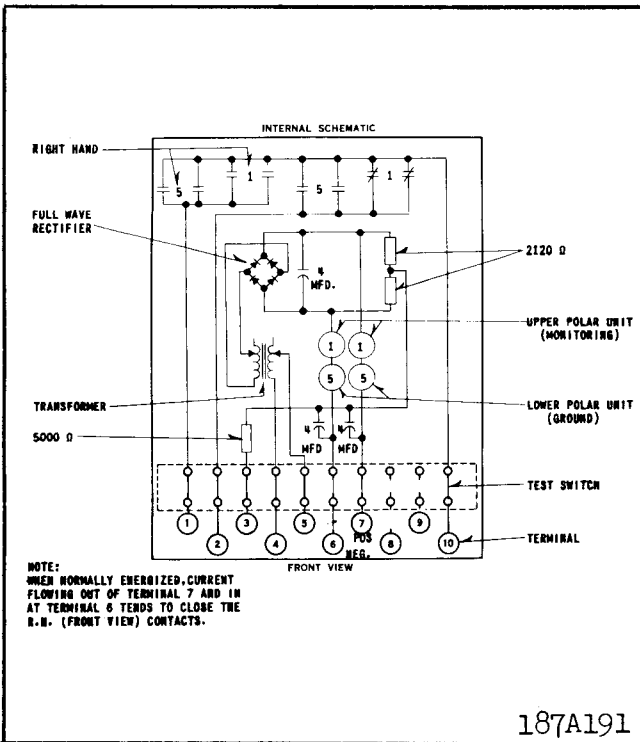

Fig. 4. Internal schematic of type PMA relay in FT 31 case - 120 volt, 60 hertz supply - For three terminal lines.

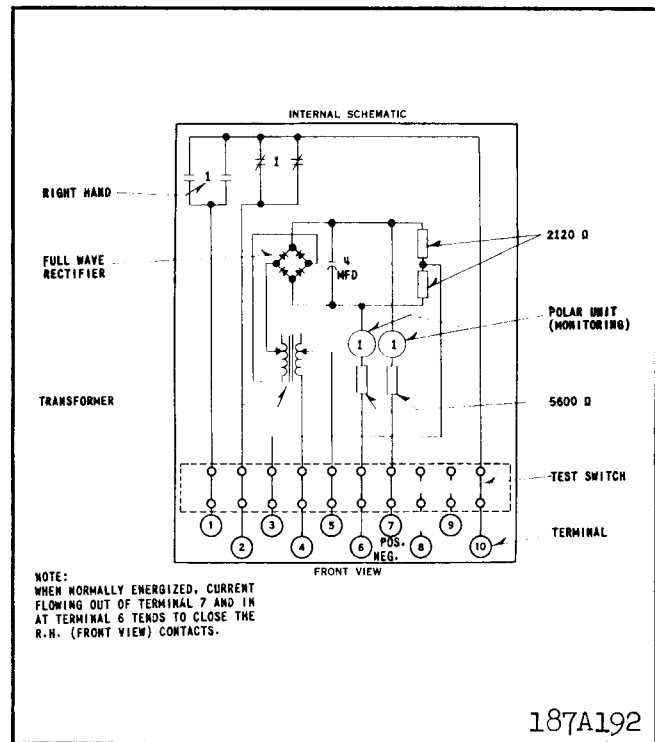

Fig. 5. Internal schematic of type PMA-1 relay in FT 21 case - 120 volt, 60 hertz supply - For three terminal lines.

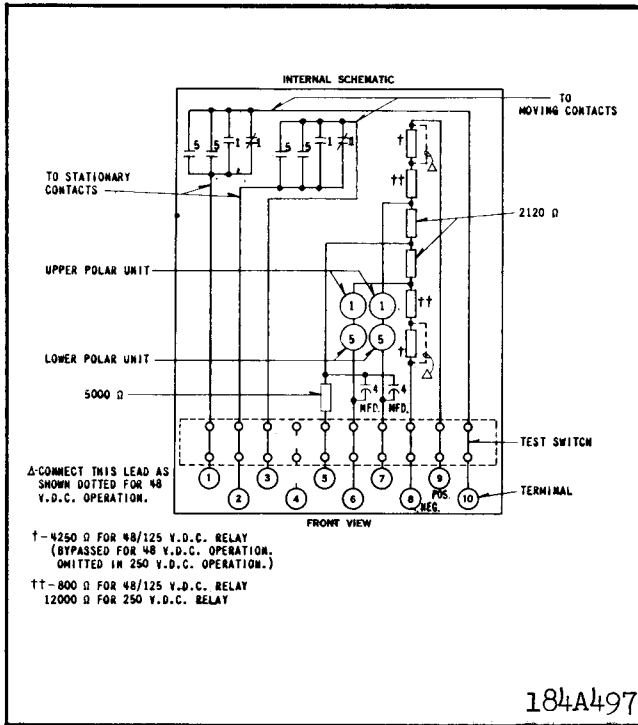

Fig. 6. Internal schematic of the type PMD relay in FT 21 case - DC supply - for two terminal lines.

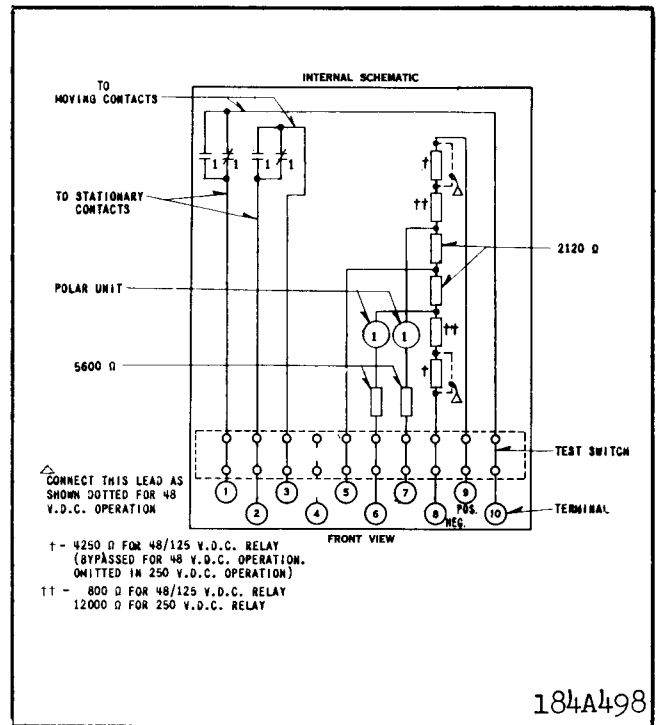

Fig. 7. Internal schematic of the type PMD-1 relay in the FT 11 case - DC supply - For two terminal lines.

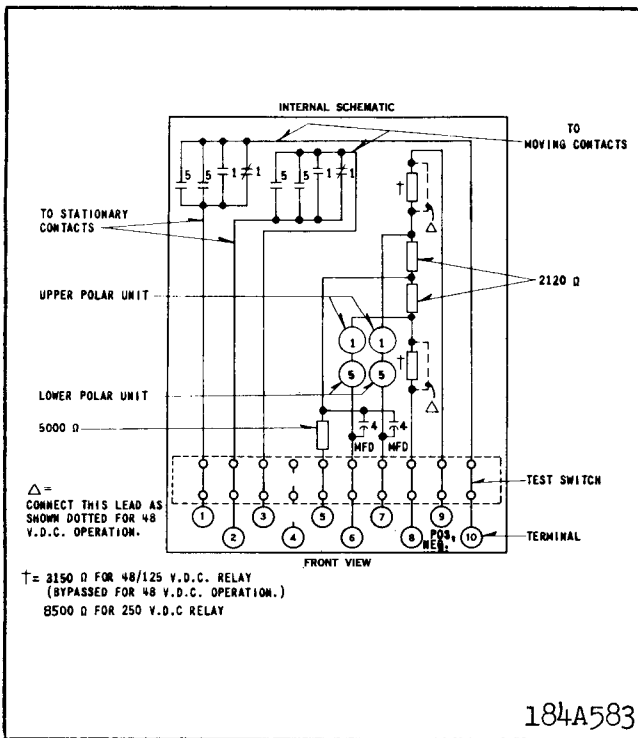

Fig. 8. Internal schematic of the type PMD relay in the FT 21 case - DC supply - For three terminal lines.

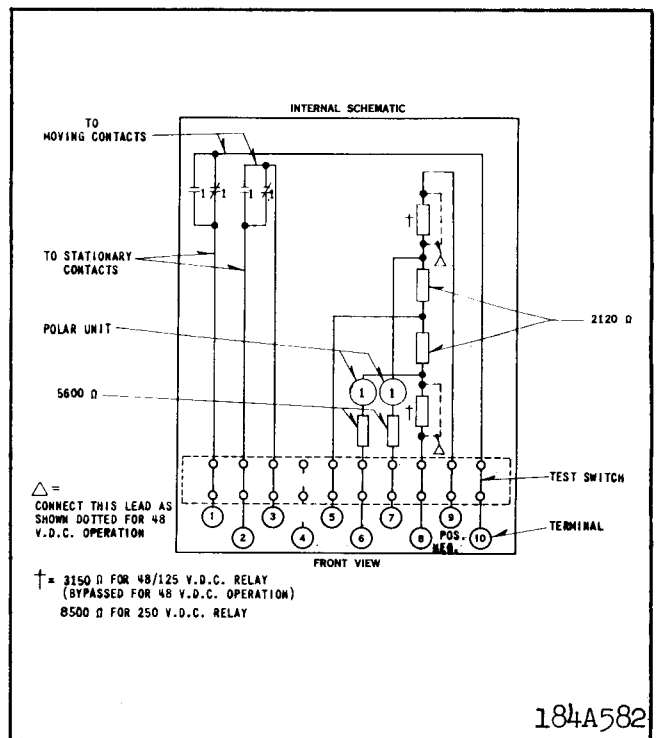

Fig. 9. Internal schematic of the type PMD-1 relay in the FT 11 case - DC supply - For three terminal lines.

TYPE PM MONITORING RELAYS

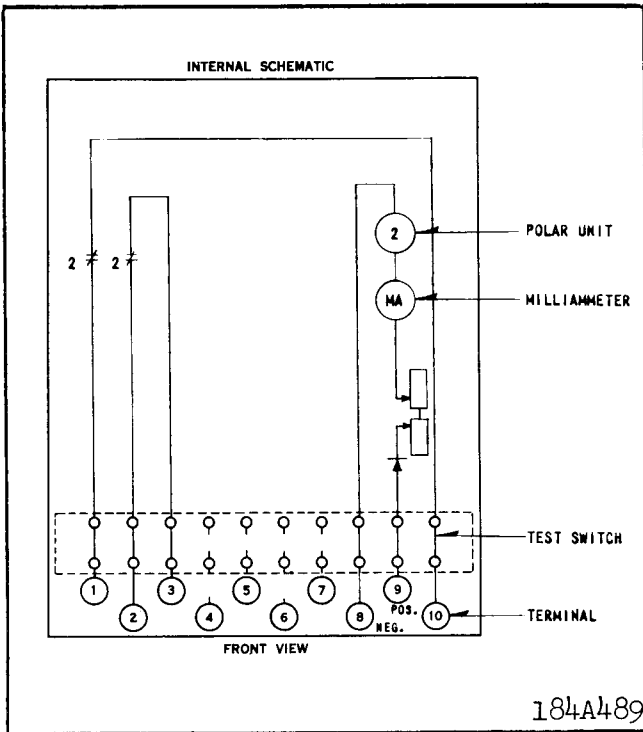

Fig. 10. Internal schematic of the type PM-2 relay in the FT 21 case.

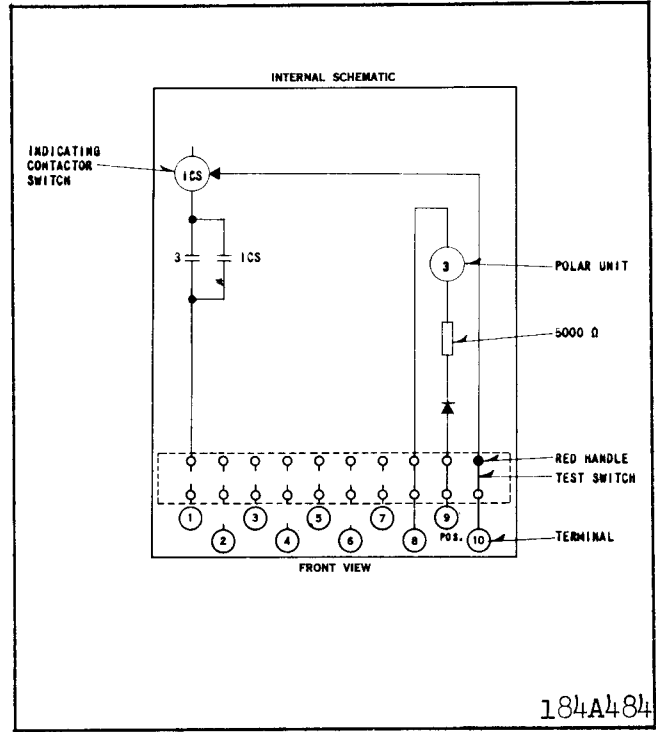

Fig. 11. Internal schematic of the type PM-3 relay in the FT 11 case.

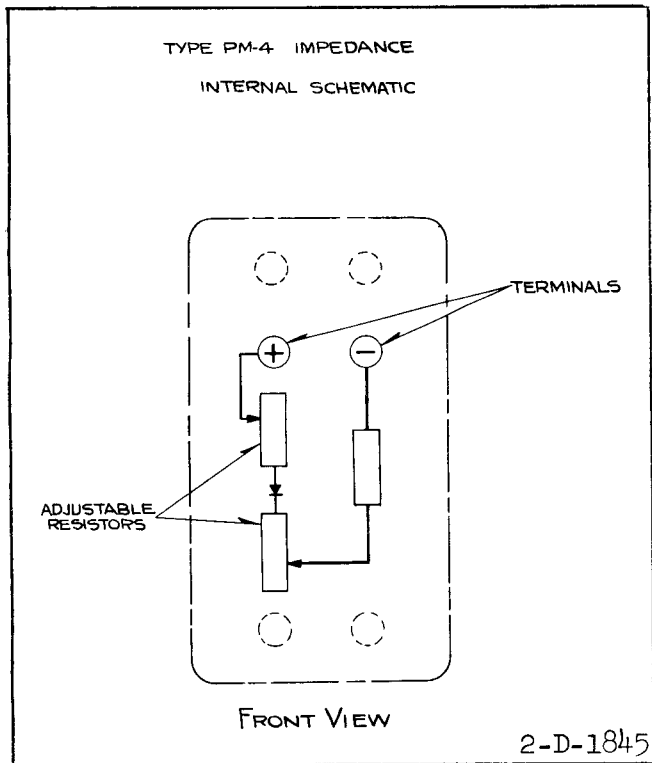

Fig. 12. Internal schematic of the type PM-4 Auxiliary Unit in the small molded case.

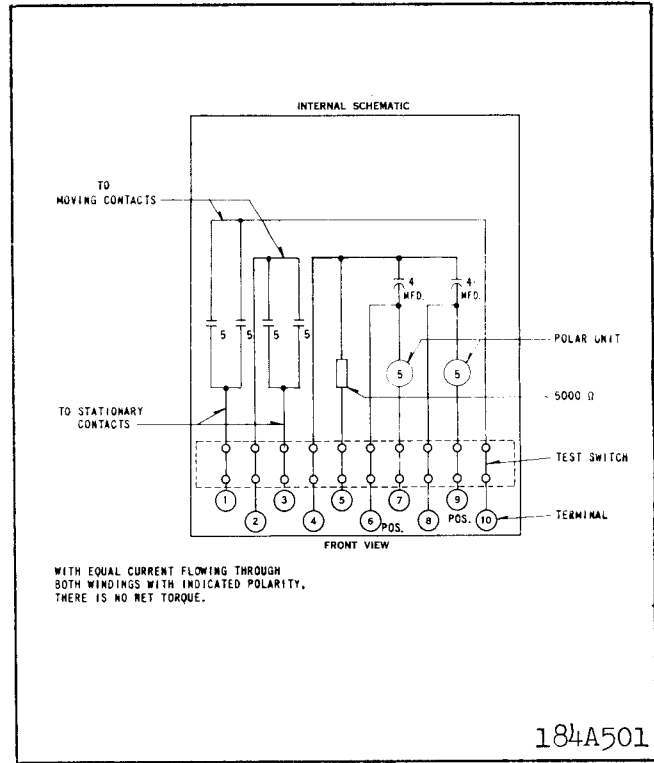

Fig. 13. Internal schematic of the type PM-5 ground detector relay in the FT 11 case.

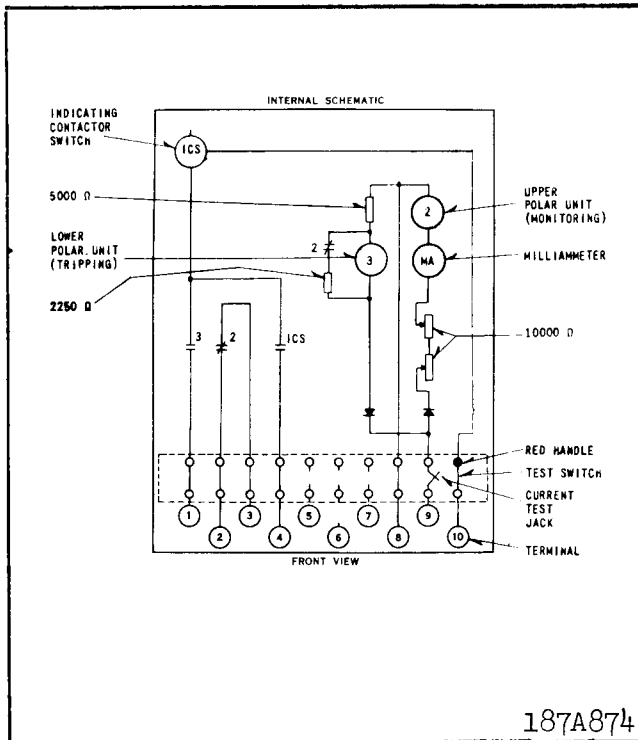

Fig. 14. Internal schematic of the type PM-23 relay in the FT 21 case.

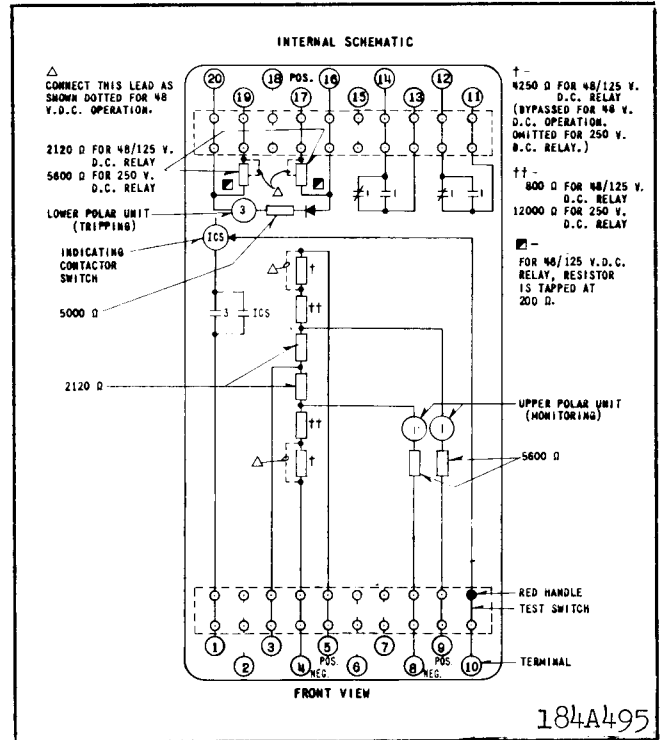

Fig. 15. Internal schematic of the type PM-13 relay in the FT 32 case - DC supply - For two terminal lines.

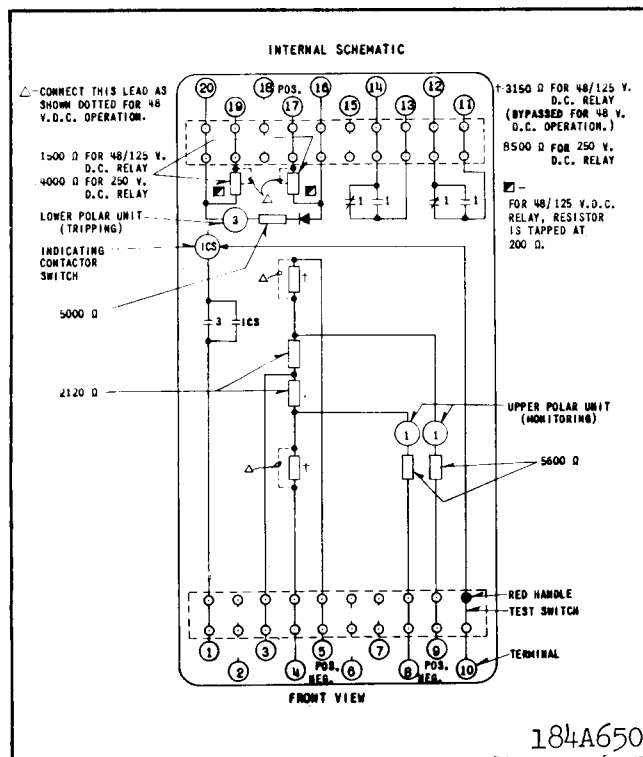

Fig. 16. Internal schematic of the type PM-13 relay in the FT 32 case - DC supply - For three terminal lines.

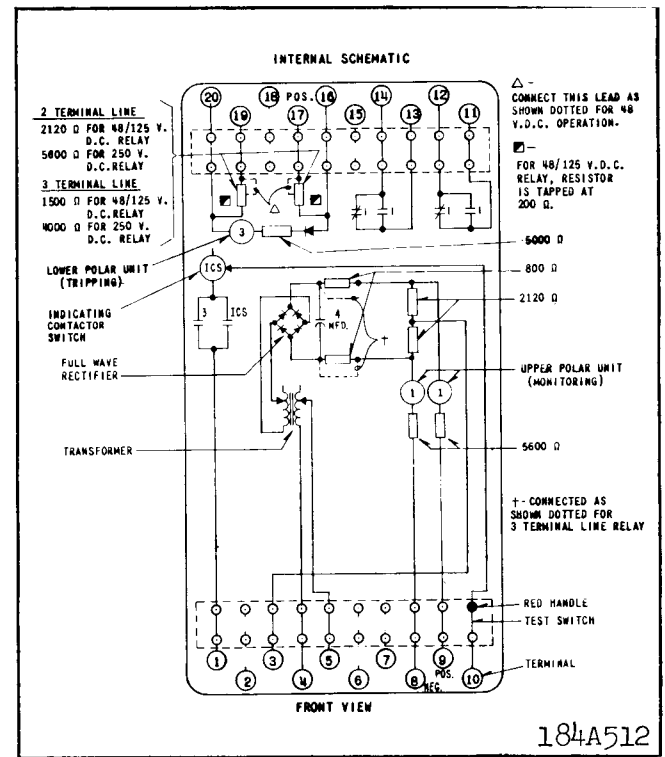

Fig. 17. Internal schematic of the type PM-13 relay in the FT 32 case - 120 volt, 60 hertz supply - For two or three terminal lines.

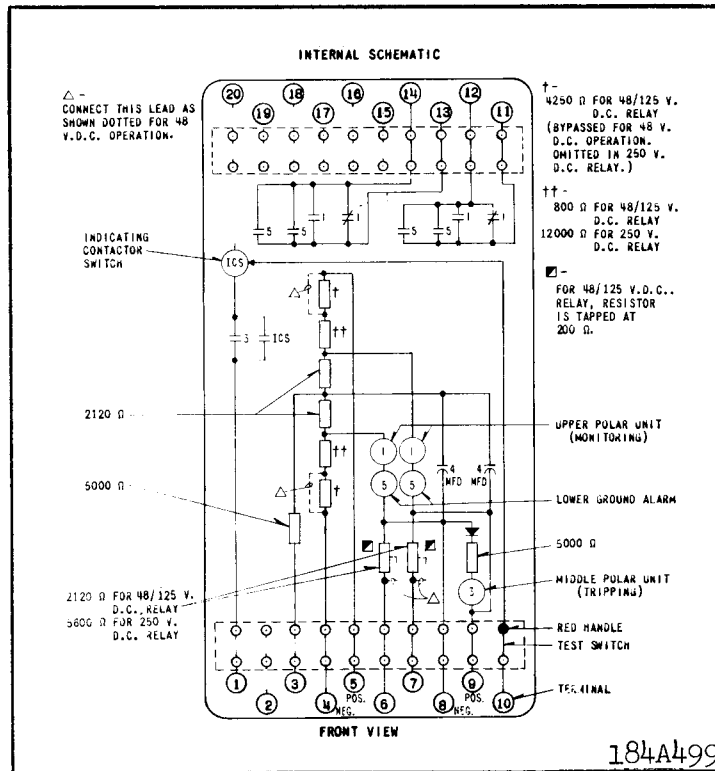

Fig. 18. Internal schematic of the type PMG-13 relay in the FT 32 case - DC supply - For two terminal lines.

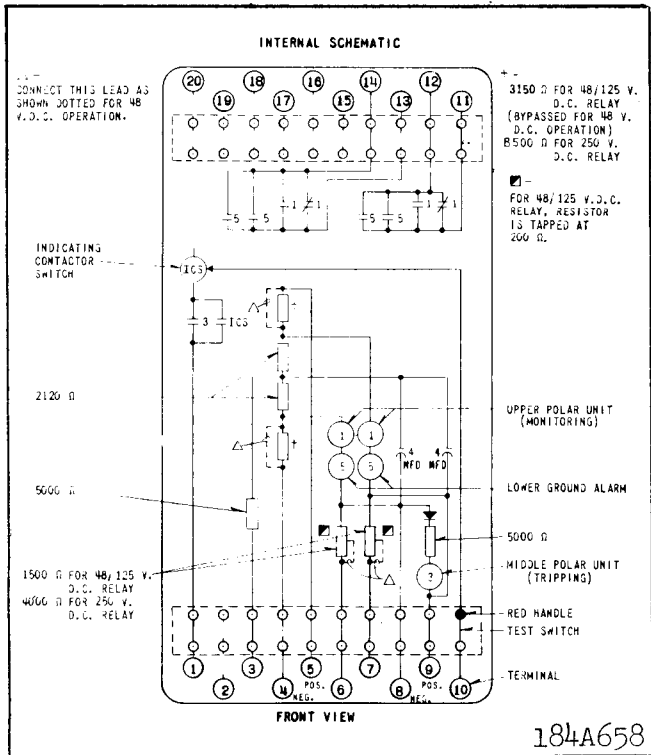

Fig. 19. Internal schematic of the type PMG-13 relay in the FT 32 case - DC supply - For three terminal lines.

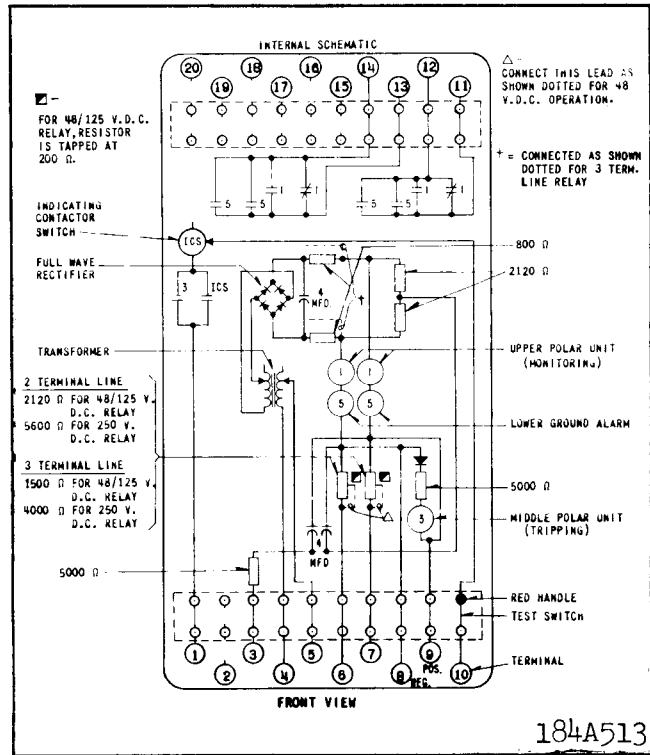

Fig. 20. Internal schematic of the type PMG-13 relay in the FT 32 case - 120 volt, 60 hertz supply - For two or three terminal lines.

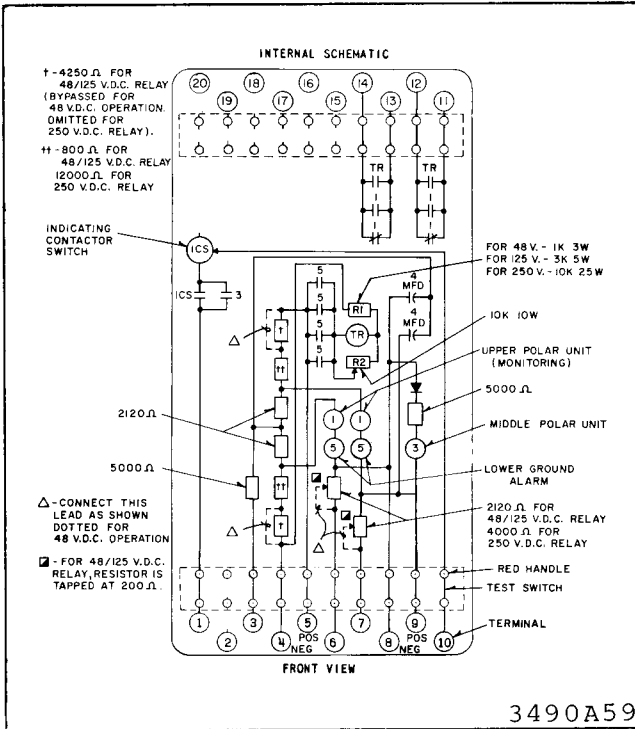

Fig. 21. PMG-13 Relay with Ground Alarm and Remote Trip - Two Terminal Lines with Telephone Relay Output. FT-32 Case.

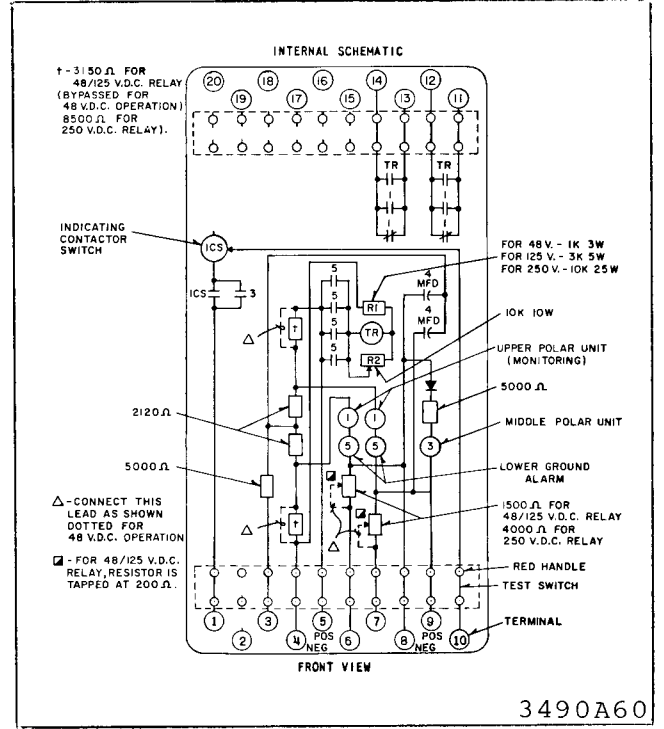

Fig. 22. PMG-13 Relay with Ground Alarm and Remote Trip - Three Terminal Lines with Telephone Relay Output - FT-32 Case.

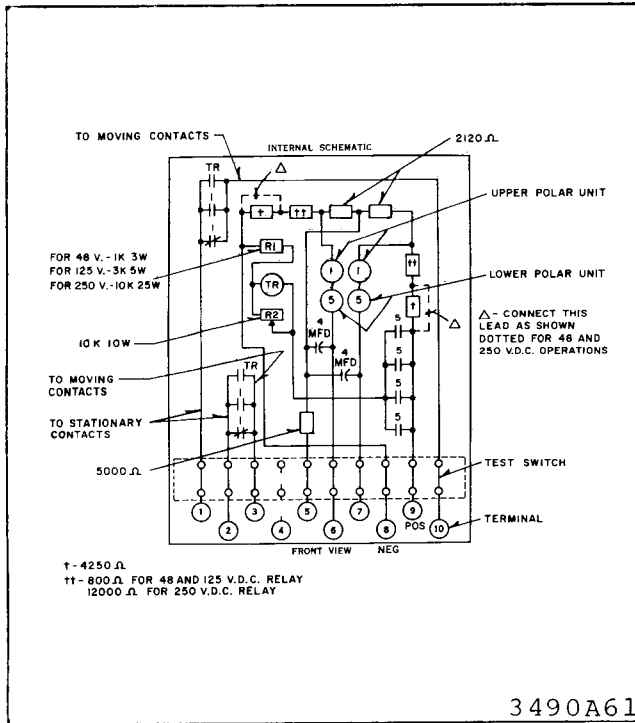

Fig. 23. PMD Relay - Ground Alarm, D.P.D.T. Contacts, Two Terminal Lines with Telephone Relay Output - FT-21 Case.

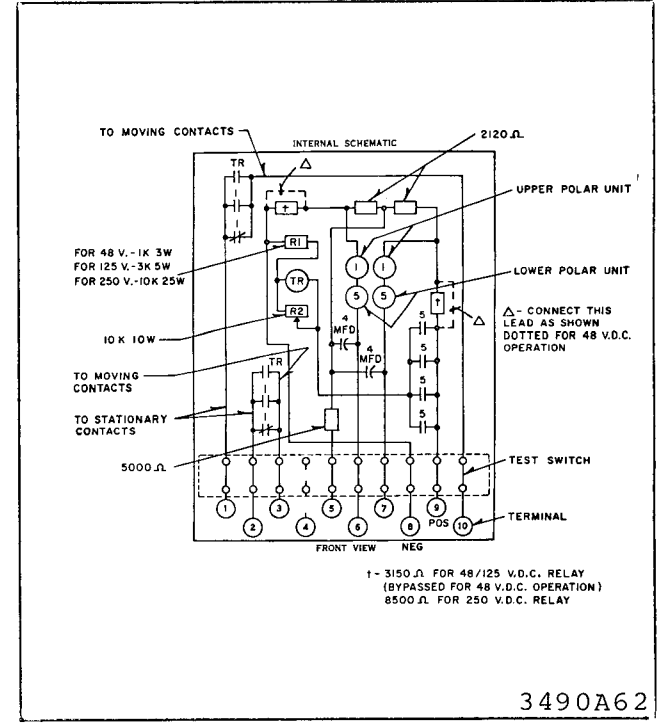

Fig. 24. PMD Relay - Ground Alarm, D.P.D.T. Contacts, Three Terminal Lines with Telephone Relay Output - FT-21 Case.

TYPE PM MONITORING RELAYS

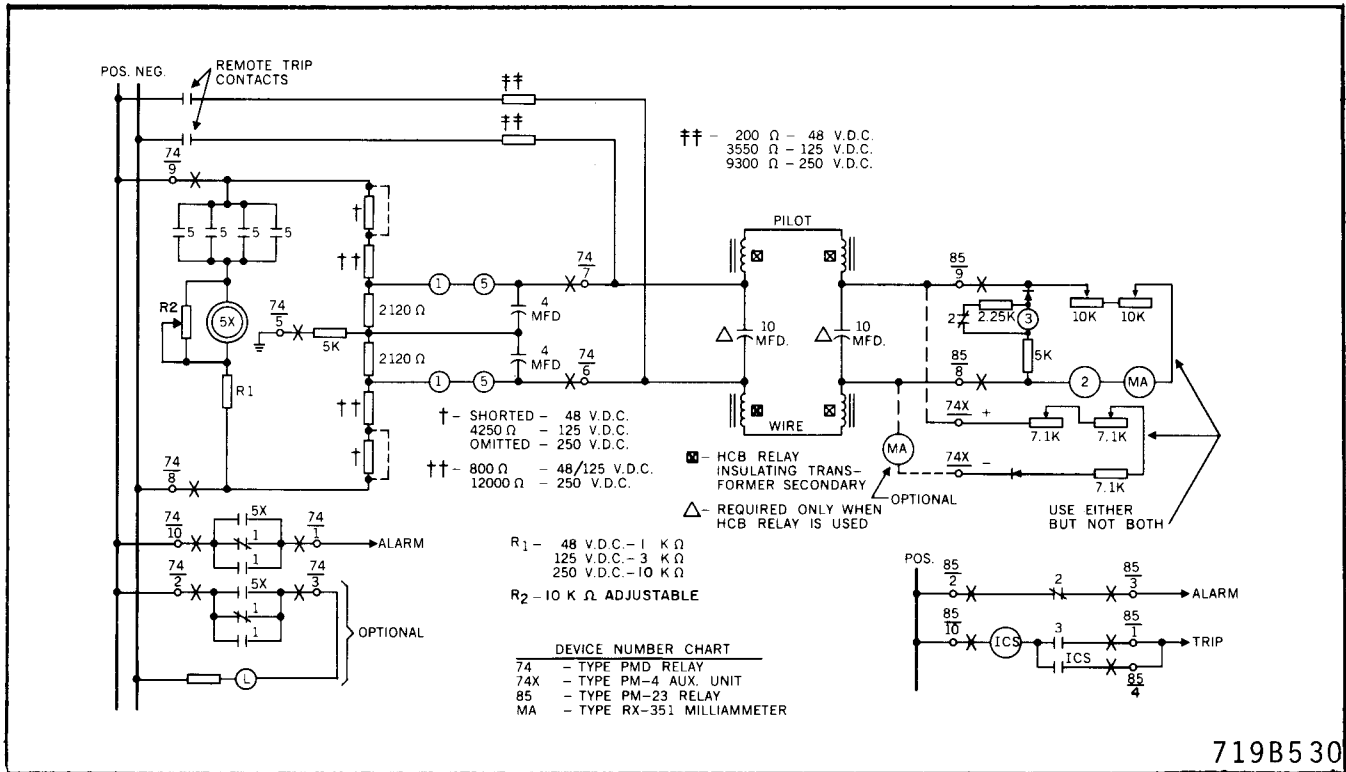

Fig. 25. External schematic of the type PMD relay with type PM-23 or PM-4 relay - Two terminal lines.

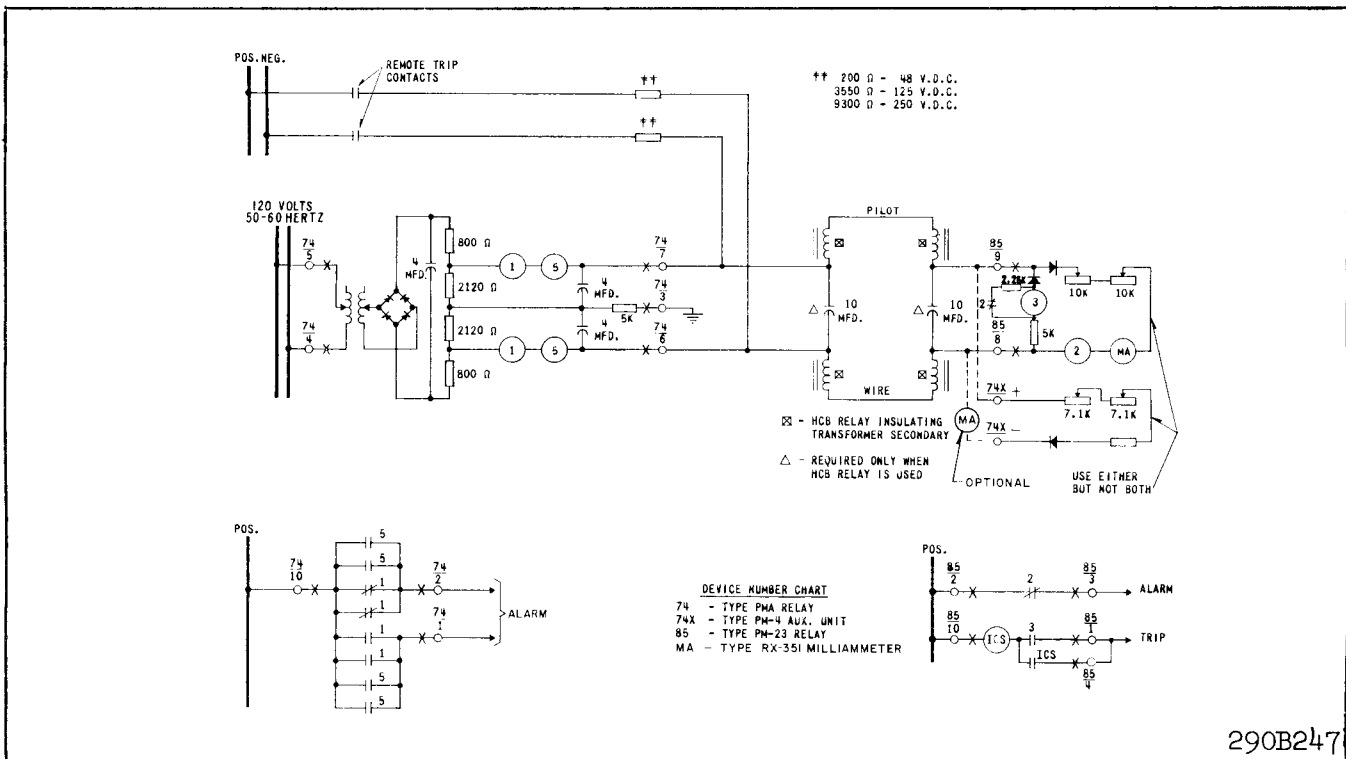
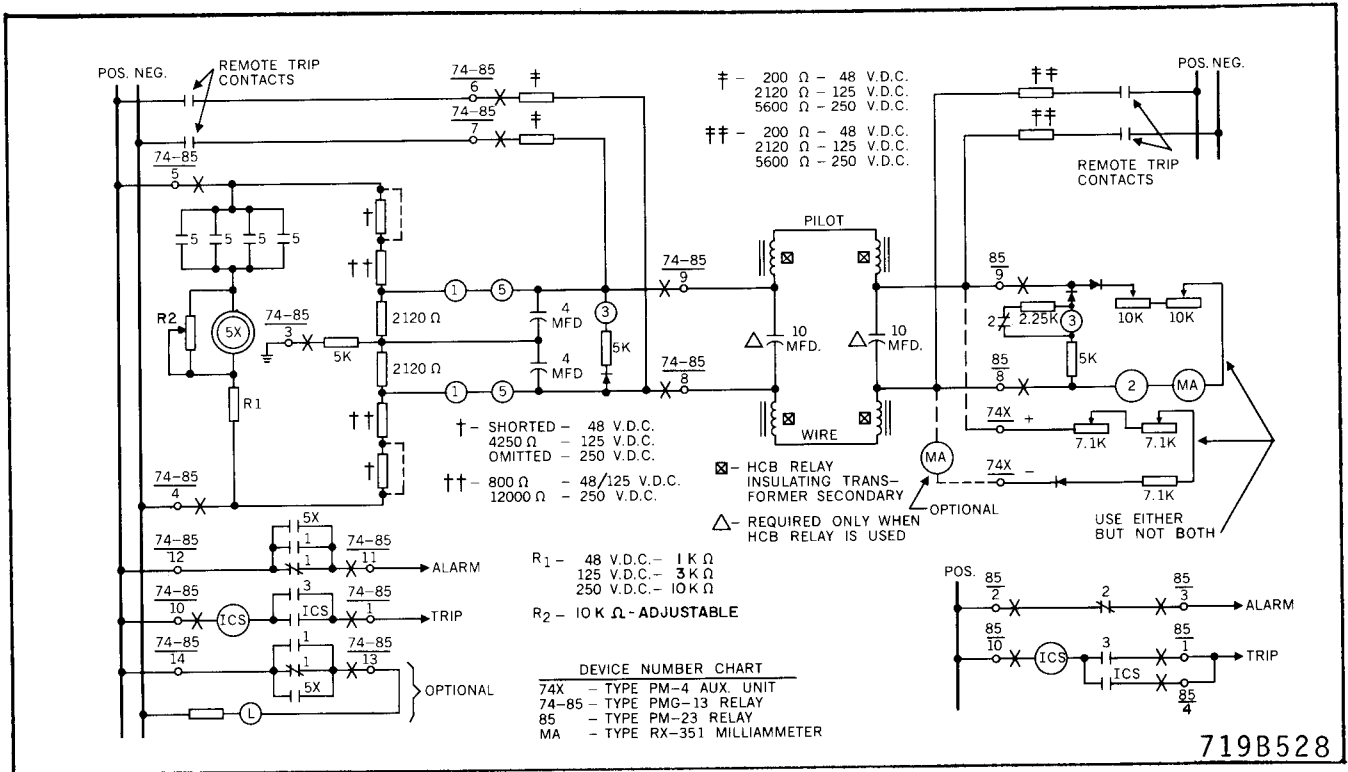

Fig. 26. External schematic of the type PMA relay with type PM-23 or PM-4 relay - Two terminal lines.



★ Fig. 27. External schematic of the DC type PMG-13 relay with type PM-23 or PM-4 relay - Two terminal lines.

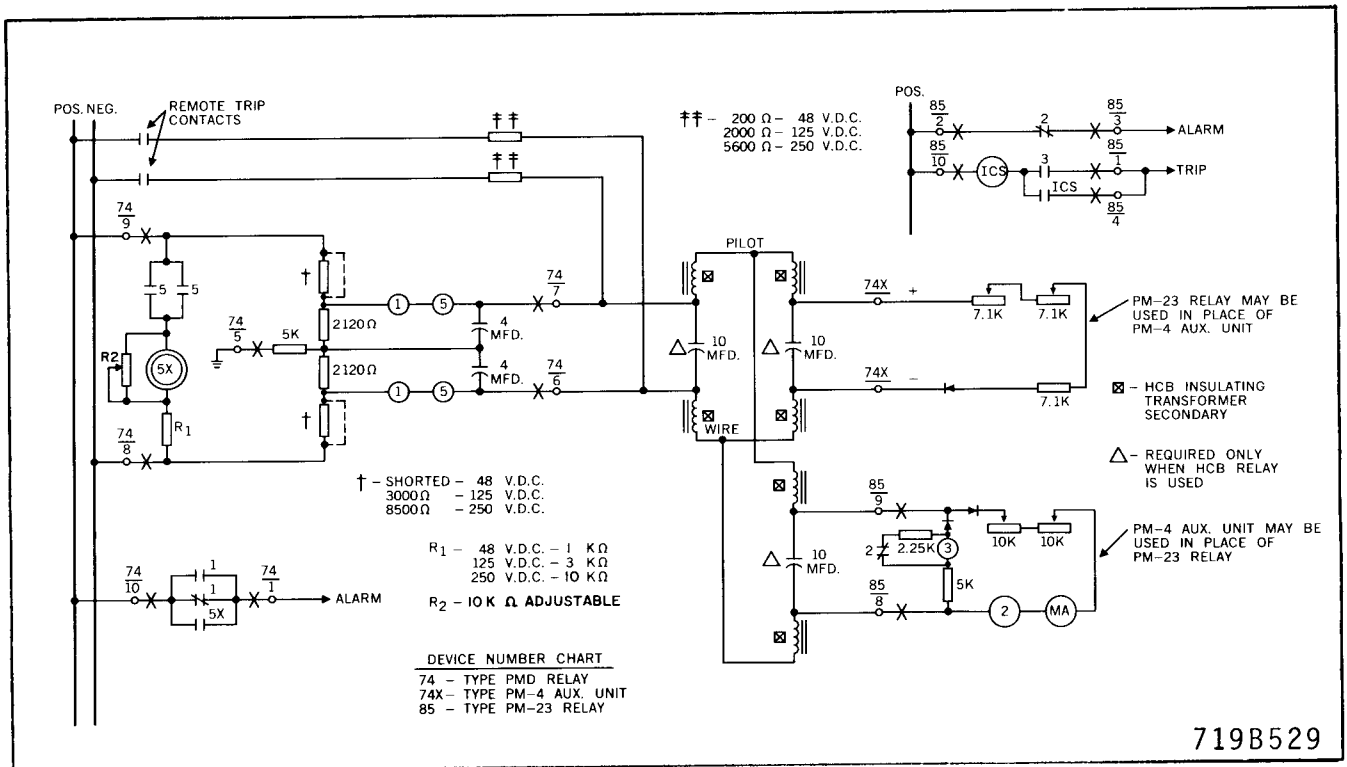

Fig. 28. External schematic of the type PMD relay with type PM-23 and PM-4 relays - Three terminal lines.

TYPE PM MONITORING RELAYS

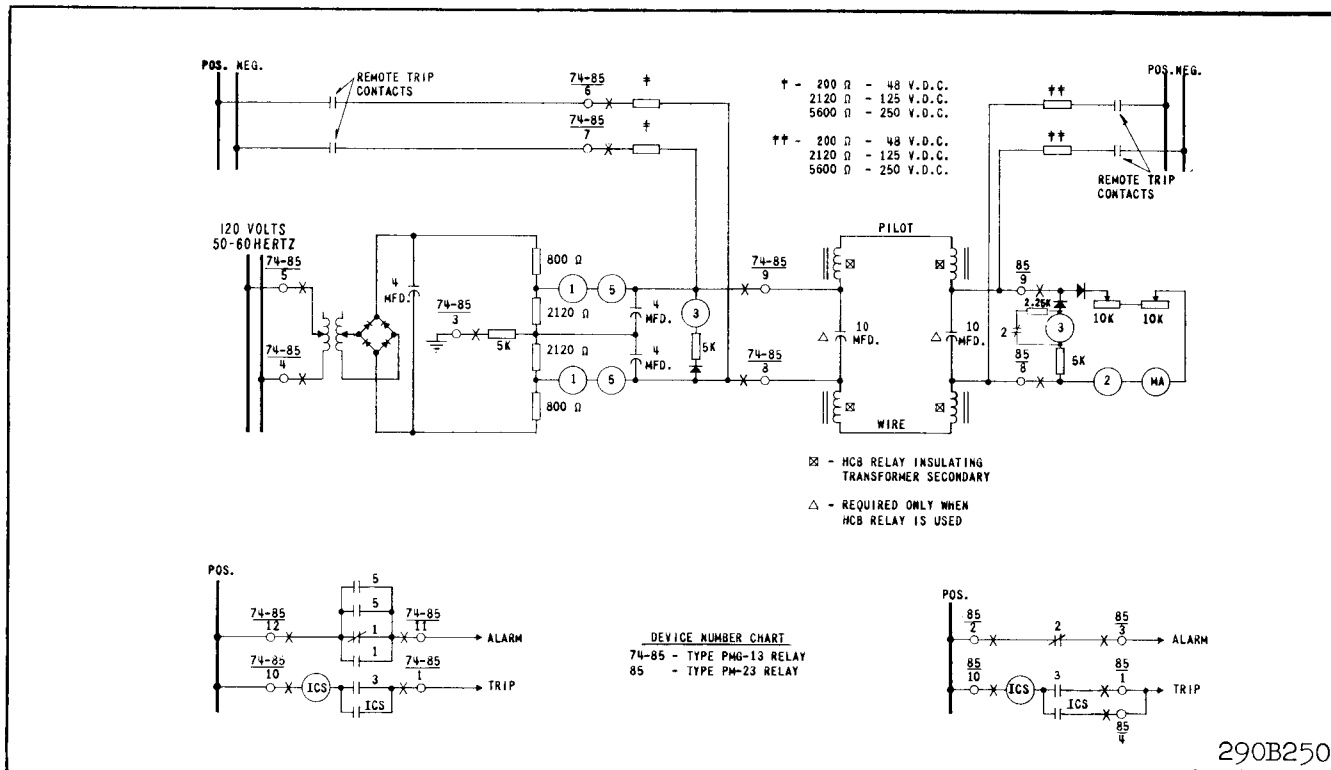

Fig. 29. External schematic of the AC type PMG-13 with type PM-23 relay - Two terminal lines.

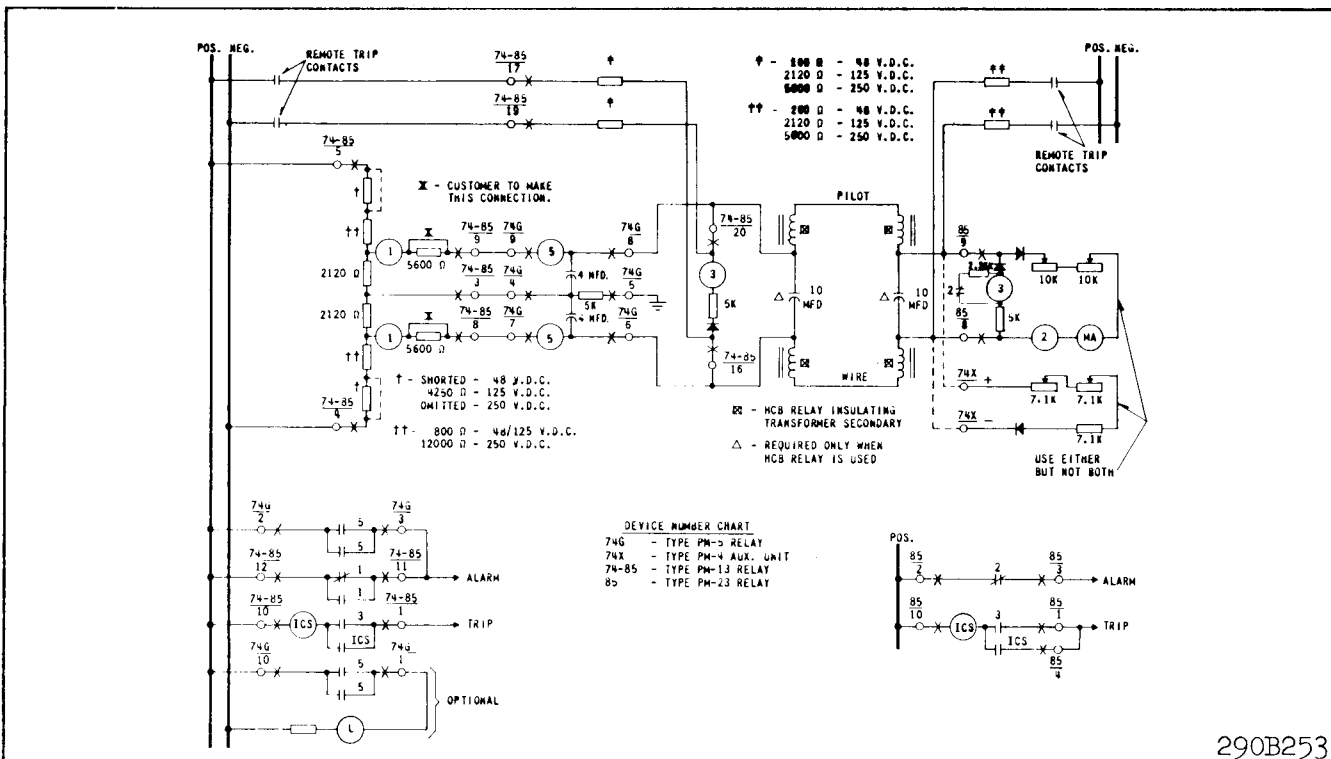

Fig. 30. External schematic of the DC type PM-13 and PM-5 relay with type PM-23 or PM-4 relay - Two terminal lines.

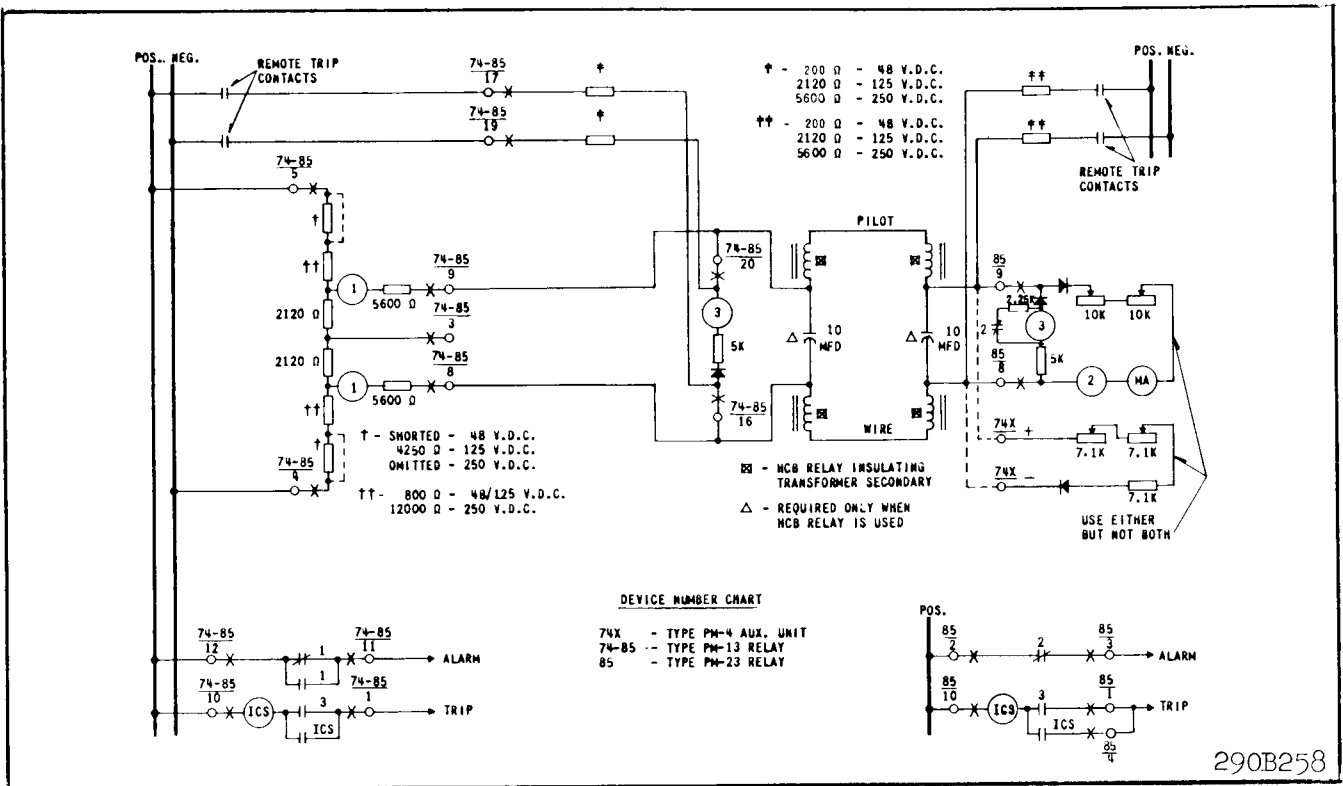

Fig. 31. External schematic of the DC type PM-13 relay with type PM-23 or PM-4 relay - Two terminal lines.

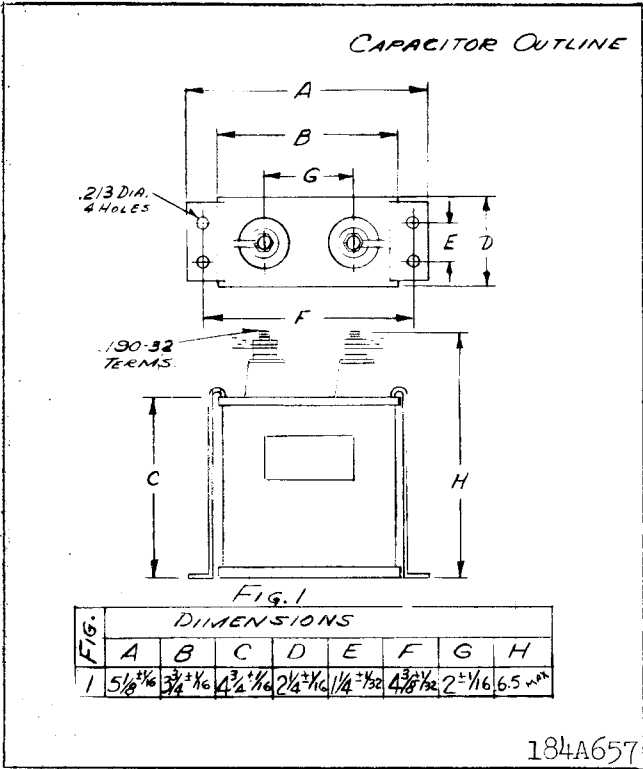

Fig. 32. Outline and Drilling Plan for 10 mfd. capacitor - For reference only.

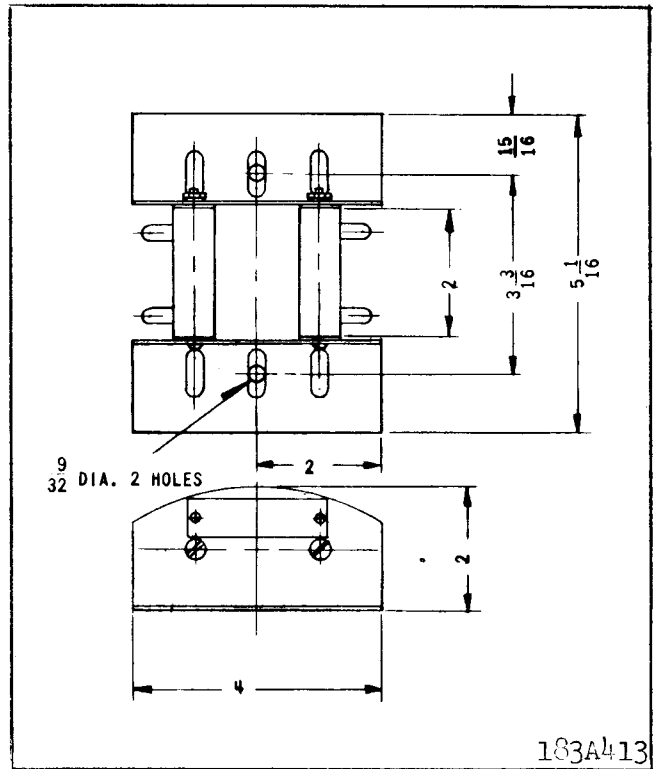

Fig. 33. Outline and Drilling Plan for External Remote Trip Resistor Assembly.

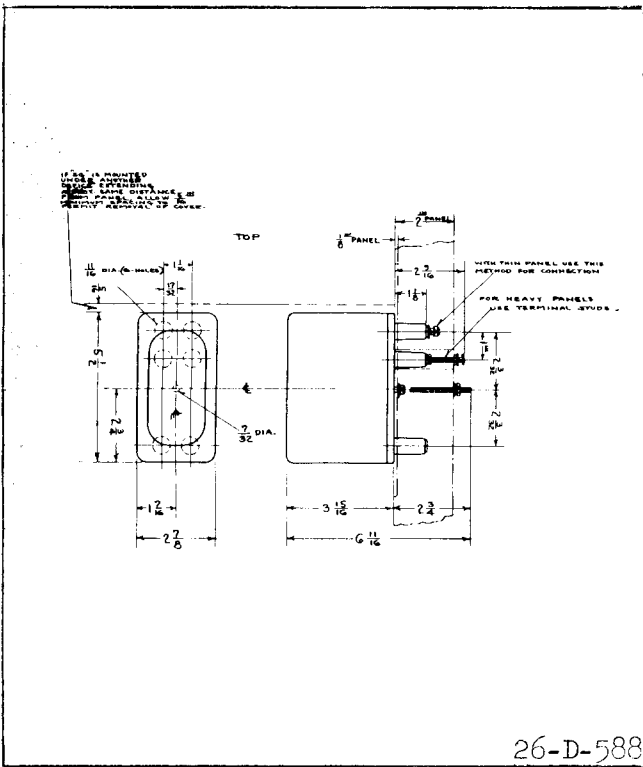

Fig. 34. Outline and Drilling Plan for the type PM-4 Auxiliary unit in the projection molded case.

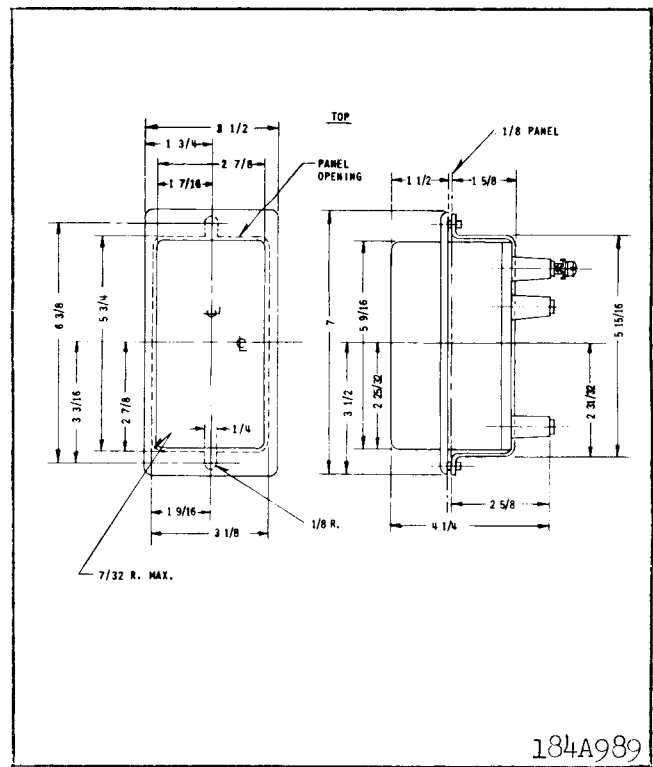

Fig. 35. Outline and Drilling Plan for the type PM-4 Auxiliary unit in the Semi-Flush molded case.

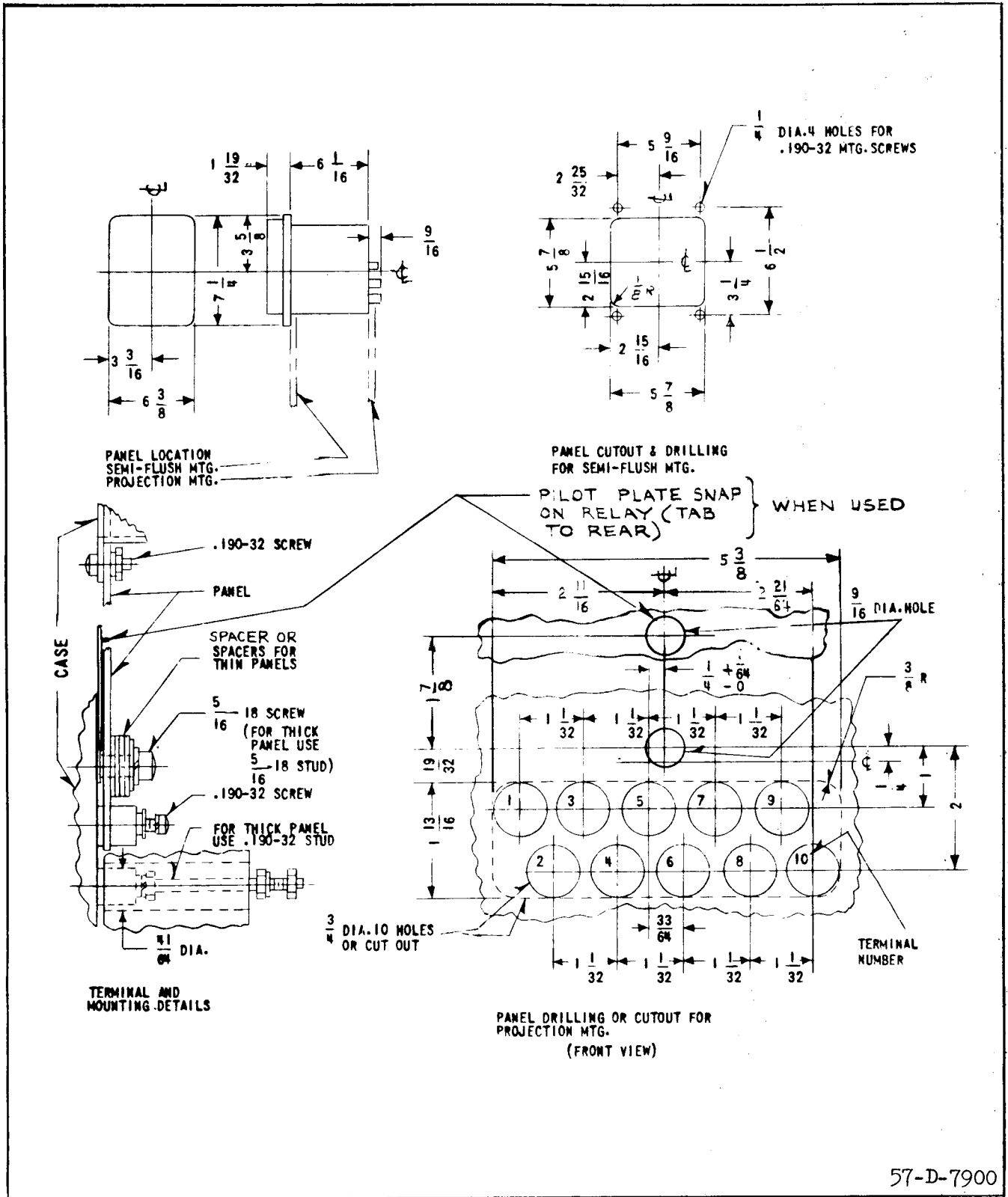

Fig. 36. Outline and Drilling Plan for the type PM-3, PM-5, & PMD-1 Relays in the type FT 11 case.

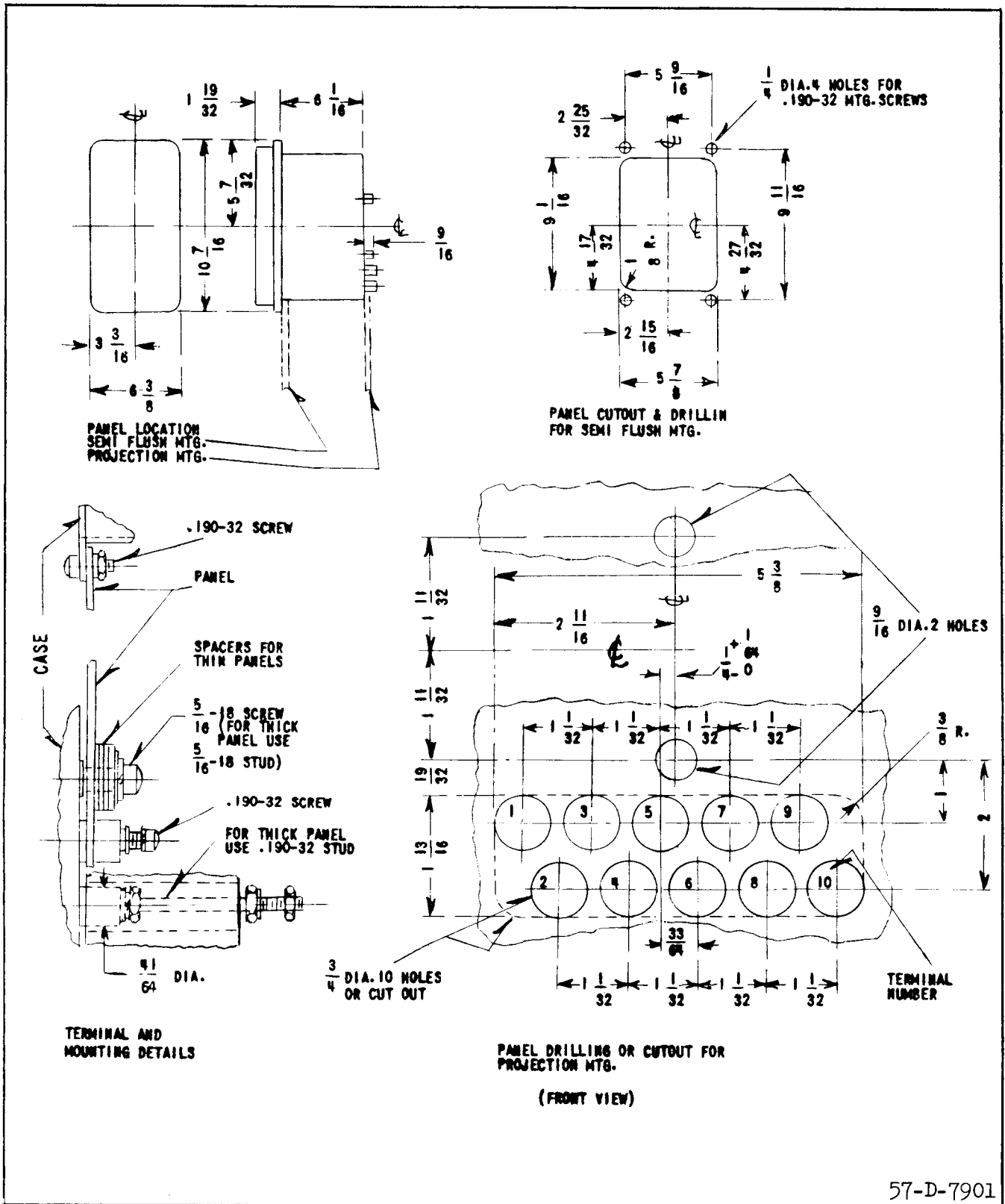

Fig. 37. Outline and Drilling Plan for the type PM-2, PM-23, PMA-1 and PMD relays in the type FT 21 case.

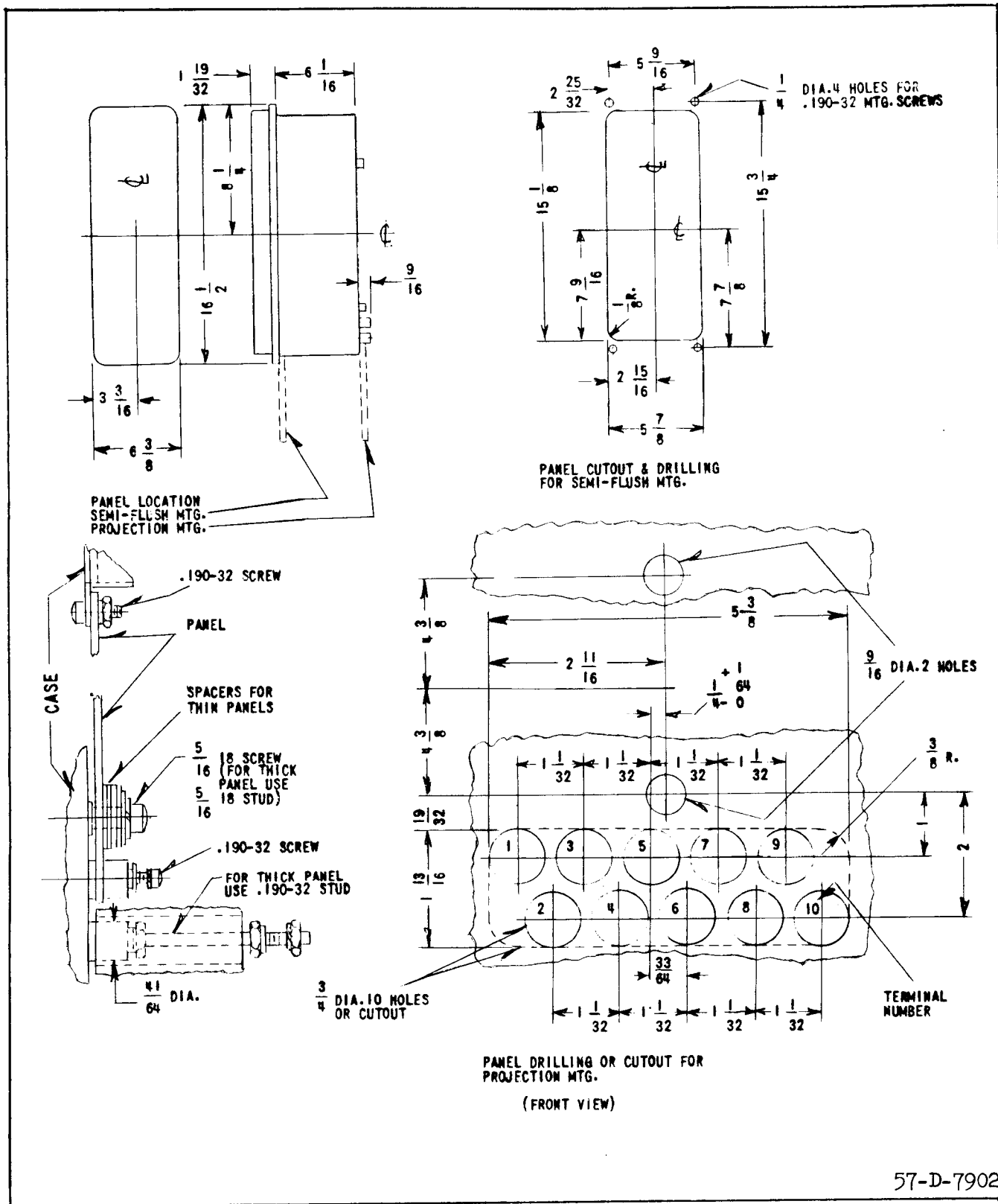
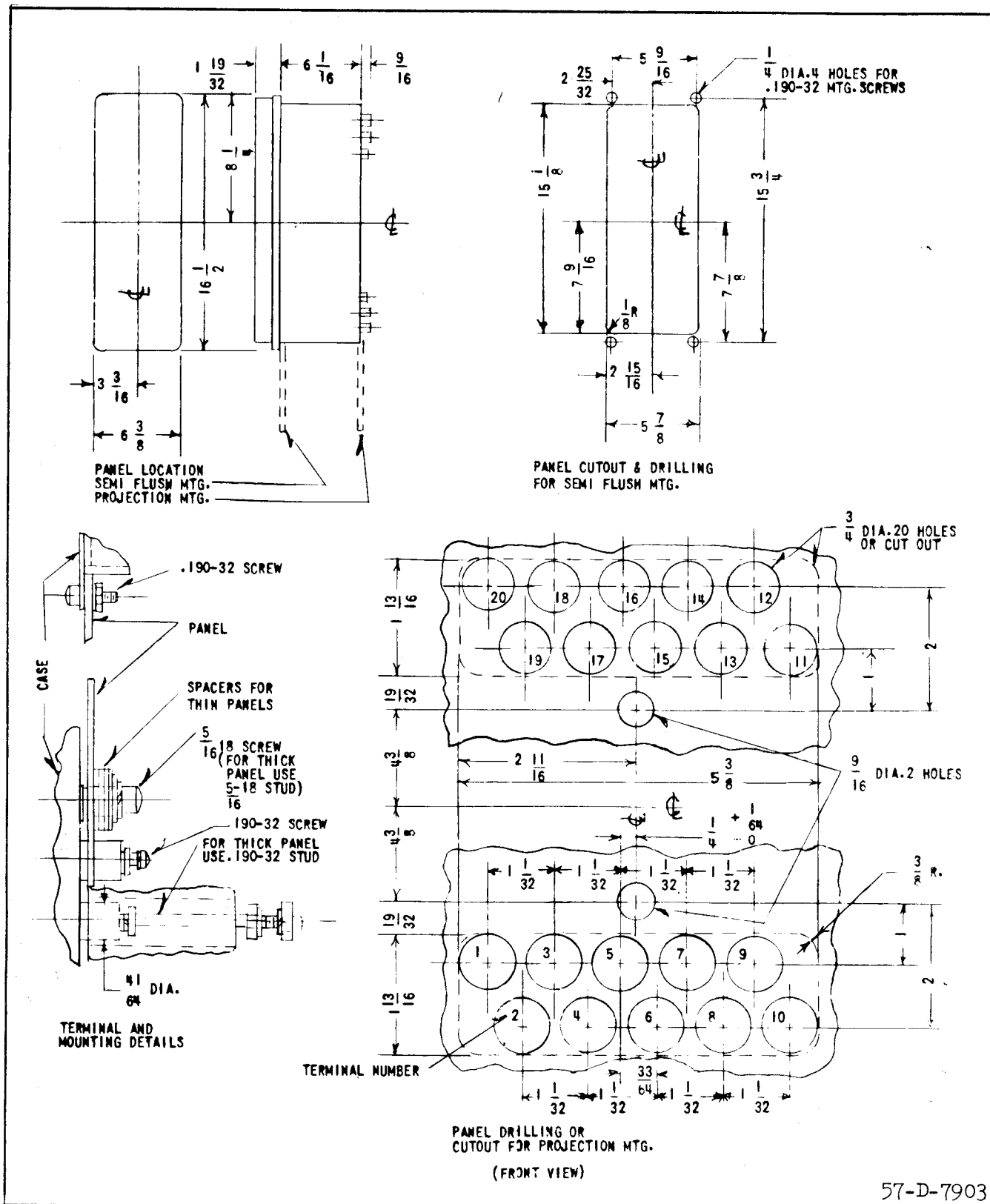

Fig. 38. Outline and Drilling Plan for the type PMA relay in the type FT 31 case.



57-D-7903

Fig. 39. Outline and Drilling Plan for the type PM-13 and PMG-13 relays in the type FT 32 case.



INSTALLATION • OPERATION • MAINTENANCE INSTRUCTIONS

TYPE PM LINE OF RELAYS FOR PILOT-WIRE MONITORING AND TRANSFERRED TRIPPING

CAUTION Before putting protective relays into service, remove all blocking which may have been inserted for the purpose of securing parts during shipment, make sure that all moving parts operate freely, inspect the contacts to see that they are clean and close properly, and operate the relay to check the settings and electrical connections.

APPLICATION

Type PM Monitoring Relays provide continuous monitoring of a pilot-wire circuit to detect open circuits, short circuits, grounds, and wire reversal. In addition, transferred tripping can be effected where the PM-3, PM-13, PMG-13 or PM-23 relays are used. Table I illustrates the functions available with each relay. A 10 mfd. capacitor is supplied with each PM relay. This capacitor provides an a-c path between the two halves of the insulating transformer secondary windings as shown in Figs. 21 through 27.

Each circuit requires the following:

At one end to introduce monitoring current

One of the following:

For a-c Supply

For d-c Supply

PMA	PMD
PMA-1.	PMD-1
PM-13 or PMG-13 (a.c.)	PM-13 or PMG-13 (d.c.)

At the other end to receive monitoring current (two-terminal line)

One PM-23 or PM-2 or PM-4

At the other ends to receive monitoring current (three-terminal line)

* One PM-23 or one PM-4 or one PM-2 for each remote terminal.

CONSTRUCTION

PM relays consist of the following:

<u>PMA</u>	<u>PMA-1</u>
1-Polar Alarm Unit (1)	1-Polar Alarm Unit

1-Polar Ground Unit (5)	1-Tapped Transformer	1-Tapped Transformer
1-Tapped Transformer	1-Full-Wave Rectifier	1-Full-Wave Rectifier
1-Full-Wave Rectifier	3-4 mfd. Capacitors	1-4 mfd. Capacitor
3-4 mfd. Capacitors	1-Set of Potential	1-Set of Potential
1-Set of Potential	Dividing Resistors	Dividing Resistors

PMD

PMD-1

1-Polar Alarm Unit (1)	1-Polar Alarm Unit
1-Polar Ground Unit (5)	1-Set of Potential
2-4 mfd. Capacitors	Divider Resistors
1-Set of Potential	
Divider Resistors	

PMG-13

PM-13

1-Polar Alarm Unit (1)	1-Polar Alarm Unit (1)
1-Polar Ground Unit (5)	1-Polar Trip Unit (3)
1-Polar Trip Unit (3)	1-Indicating Contactors
1-Indicating Contactor	Switch
Switch	1-Set of Potential
1-Set of Potential	Divider Resistors
Divider Resistors	1-Tapped Transformer
1-Tapped Transformer	(A.C. Relay only)
(A.C. Relay only)	1-Full-Wave Rectifier
1-Full-Wave Rectifier	(A.C. Relay only)
(A.C. Relay only)	1-Blocking Rectifier
1-Blocking Rectifier	2-Remote Trip Resistor
2-Remote Trip Resistors	1-4 mfd. Capacitor
3-4 mfd. Capacitors	
(A-C Relay)	
2-4 mfd. Capacitors	
(D-C Relay)	

PM-23

PM-2

1-Polar Alarm Unit (2)	1-Polar Alarm Unit (2)
1-Polar Trip Unit (3)	1-Milliammeter, 5.0 ma.
1-Indicating Contactor	1-Set of Adjustable
Switch (ICS)	Resistors
1-Milliammeter, 5.0 ma.	1-Blocking Rectifier
1-Set of Adjustable and	
Fixed Resistors	
2-Blocking Rectifiers	

SUPERSEDES I.L. 41-973.5J

*Denotes change from superseded issue.

EFFECTIVE OCTOBER 1974

TYPE PM MONITORING RELAYS

PM-3
 1—Polar Trip Unit (3)
 1—Resistor
 1—Blocking Rectifier
 1—Indicating Contactor
 Switch (ICS)

PM-4
 1—Blocking Rectifier
 1—Set of Adjustable &
 Fixed Resistors

PM-5
 1—Polar Ground Unit (5)
 2—4 mfd. Capacitors
 1—Fixed Resistor

TABLE I

FUNCTION	PMA & PMD	PMA-1 & PMD-1	PM-13	PMG-13	PM-23	PM-2	PM-3	PM-4	PM-5
Monitoring Current Source	X	X	X	X					
Receives Monitoring Current					X	X		X	
Trouble Alarm	X	X	X	X	X	X			X
Transmits Trip Signal	X †	X †	X	X	X †	X †	X †	X †	
Receives Trip Signal			X	X	X		X		
Sensitive Ground Detection	X			X					X
Measures Monitoring Current					X	X			

† With External Resistors

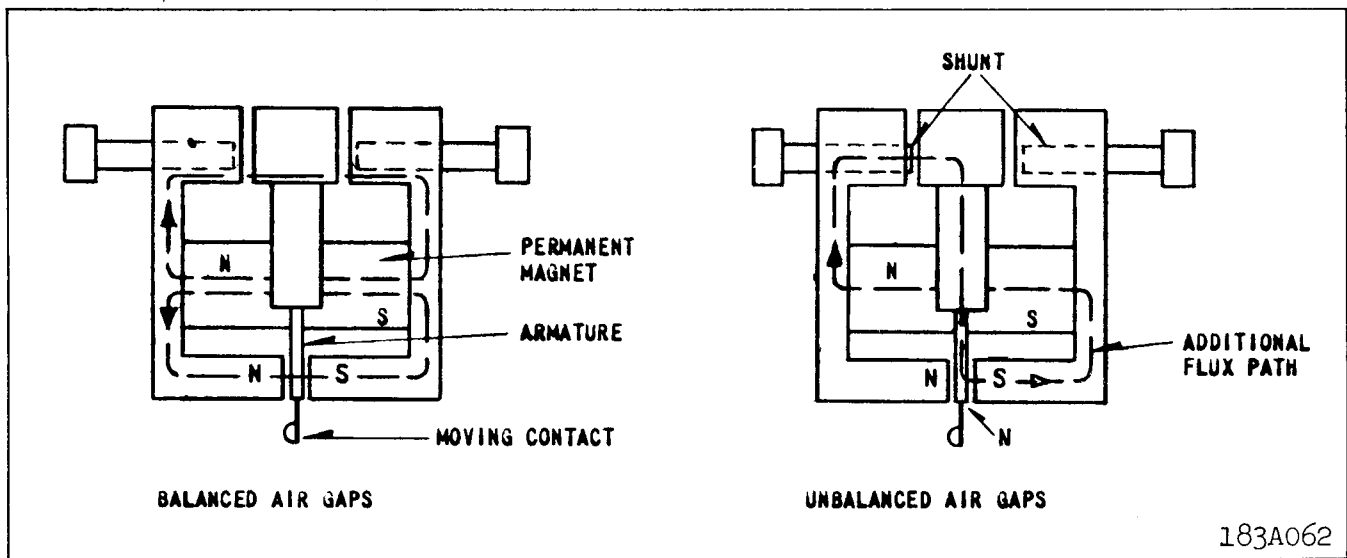

Fig. 1. Polar Unit Permanent Magnet Flux Paths.

Polar Unit

The polar unit consists of a rectangular shaped magnetic frame, an electromagnet, a permanent magnet, and an armature. The poles of the crescent shaped permanent magnet bridge the magnet frame. The magnetic frame consists of three pieces joined in the rear with two brass rods and silver solder. These non-magnetic joints represent air gaps, which are bridged by two adjustable magnetic shunts. The winding or windings are wound around a magnetic core. The armature is fastened to this core and is free to move in the front air gap. The moving contact is connected to the free end of a leaf spring, which, in turn, is fastened to the armature.

Indicating Contactor Switch

The d-c indicating contactor switch is a small clapper type device. A magnetic armature, to which leaf-spring mounted contacts are attached, is attracted to the magnetic core upon energization of the switch. When the switch closes, the moving contacts bridge two stationary contacts, completing the trip circuit. Also during this operation two fingers on the armature deflect a spring located on the front of the switch, which allows the operation indicator target to drop. The target is reset from the outside of the case by a push rod located at the bottom of the cover.

The front spring, in addition to holding the target, provides restraint for the armature and thus controls the pickup value of the switch.

PMD & PMG13 with Tel. Relay: In the relays type PMD and PMG13 where they are energized with DC power supply, the ground polar unit (#5) could momentarily close its contact (for about 10 m.s.) if either positive or negative supply is grounded. To eliminate this momentary operation, a telephone relay with a nominal operating time of 25 m.s. was connected in series with contact of the "5" unit, and the contact of the telephone relay is used as an overall contact output of the "5" unit. This type of relay should be used where the DC power supply is subjected to short to the ground.

OPERATION

Pilot Wire Monitoring

Monitoring current is introduced into the pilot wire as shown in the external schematics, figures 21 to 27, by the monitoring current source. External schematics showing other combinations are available on request. A nominal 20 volts is impressed across the 10 mfd. capacitor at the left-hand line terminal in Figures 21 to 27. This voltage produces a current circulating through one winding of the HCB insulating transformer, one pilot wire, the PM-23, PM-2, or PM-4,

and back through the other pilot wire and the other winding of HCB insulating transformer.

Adjustment of the resistors of the PM-23, PM-2 or PM-4 relay at the other end of the pilot wire provides a normal one-milliamperere d-c circulating current. In the case of three-terminal lines, the monitoring source relay output current is 2 ma. in order to provide each receiving end relay with 1 ma. The alarm unit of the monitoring current source relay is adjusted to float between the high and low current contacts with normal monitoring current. The PM-23, receiving-end alarm relay, is adjusted to float between the low-current alarm contact and a contact stop with 1 ma. flowing.

Short Circuits

A complete or partial short circuit on the pilot wires increases the current in the current-source relay, causing the high-current alarm contacts to close. The resulting current decrease in the PM-23 relay closes the alarm contact. Short circuits of 5000 ohms or less will be detected.

Open Circuits

Current decreases to zero in all relays. Low-current alarm contact of the current source relay closes. Alarm contact of PM-23 relay closes.

Reversed Wires

On applications using the PM-23 relay, current increases in the sending end relay to close the high-current alarm contacts. Current drops to zero in the PM-23 relay monitoring coil to close the low-current alarm contacts.

If the pilot wire should be opened and reclosed with reversed connections when the PM-23 relay is in service, the alarm contact (2) in the PM-23 drops out. The alarm contact dropping out shunts the trip unit coil (3), and prevents the trip unit contact (3) from operating momentarily. The trip unit contact is prevented from operating because the capacitor at the sending end discharges through the pilot wire and the trip unit (3) circuit. This will have no effect on remote trip operation.

The current decreases in both sending and receiving end relays when the PM-2, or PM-4 relays are used. Low current alarm contacts close.

Grounds

The voltage-divider circuit of the PMA, PMD, and PMG-13 source relays has its midpoint grounded through a current-limiting resistor. Thus, a pilot-wire ground will cause an increase in current in one coil circuit, and a decrease in the other one. This unbalance in the current flowing through the two windings (5) of the ground alarm relay unit will cause it to close one of its contacts (depending on which pilot

TYPE PM MONITORING RELAYS

wire is grounded) to give an alarm. Grounds of 10,000 ohms or less will be detected.

For adding the sensitive ground detection where PMA-1, PMD-1, or PM-13 relays have been installed, the PM-5 relay can be added to the circuitry, as shown in figure 24. This relay also has a 10,000-ohm ground sensitivity.

Transferred Tripping

Breakers located at the PMG-13 or PM-13 and PM-3 or PM-23 stations can be tripped by the application of a d-c voltage to the pilot wires at remote locations, as shown in figures 21 to 27. Transferred tripping can be effected from any location by applying 48 volts d-c (through dropping resistors when required) to the pilot wire with polarity opposite to that of the monitoring voltage. When tripping the PM-23, the current is increased above 2.0 ma, in reverse direction, to close the trip contact. When tripping the PMG-13 or PM-13, the reversed d.c. voltage operates the trip unit (3).

See Tables II and III for tripping resistor values. Nominal tripping currents is 5ma. at all rated voltages.

Polar Unit

Polar unit flux paths are shown in figure 1. With balanced air gaps, permanent magnet flux flows in two paths, one through the front, and one through the rear gaps. This flux produces north and south poles, as shown. By turning the left shunt in, some of the flux is forced through the armature, making it a north pole. Thus, reducing the left hand rear gap will produce a force tending to pull the armature to the right. Similarly, reducing the right hand gap will make the armature a south pole and produce a force tending to pull the armature to the left.

The alarm unit contacts of the sending and receiving end relays are biased to move to the left when the relay is deenergized. The PMG-13 or PM-13 and PM-23 trip unit contact is biased to move to the left when the relay is deenergized. The PM-5 is adjusted so that the moving contact floats when the relay is deenergized.

CHARACTERISTICS

Nominal Calibration Values

Nominal current values to close contacts are listed in Tables IV and V.

Voltage Ratings

Supply voltage ratings of the monitoring source relays to obtain continuous monitoring current are as follows:

DC - 48, 125, and 250 volts

AC - 120 volts, 60 cycles (Primary taps 100, 110, 120 & 130)

Voltage impressed on the pilot wire is a nominal 20 volts for monitoring, and 48 volts for tripping.

Supply voltage ratings to obtain remote tripping are: 48, 125, and 250 volts d-c.

Coil Resistance (each winding)

Alarm coil (1)	
two terminal line	1050-1250 ohms
three terminal line	700-900 ohms
Alarm coil (2)	2200-2600 ohms
Trip coil (3)	1800-2200 ohms
Ground Alarm coil (5)	5200-5800 ohms

PM-4 and PM-23 Resistance

Nominal PM-4 and PM-23 total resistance when adjusted for service is 20,000 ohms less pilot wire loop resistance at 1 ma.

PMA, PMA-1 and AC PMG-13, PM-13 Burden

0.5 VA at tap voltage	-	2-terminal line relay
1.0 VA at tap voltage	-	3-terminal line relay

Rectifiers

Approximate forward resistance -	560 ohms at 1 ma
	300 ohms at 2 ma

Rating

Continuous forward
current - amperes - 1

Continuous back
voltage - rms volts - 200

Remote Tripping

Remote trip resistors are listed in Table II and III for 48, 125, and 250 volts d-c.

The relays have sufficient thermal capacity to withstand 20 MA d-c continuously when remote tripping. Nominal trip currents in the tripping relays are 5.0 MA d-c with 48, 125, and 250 volts d-c supply and a 2000-ohm pilot wire.

TABLE II

**PMA, PMA-1, PMD, AND PMD-1 APPLICATIONS
EXTERNAL RESISTORS FOR D.C. REMOTE TRIPPING
(2 REQUIRED PER STATION)**

# LINE TERMINALS	D.C. VOLTAGE	STATION A PMA or PMA-1	STATION A PMD or PMD-1	STATION B PM-2 & PM-3 or PM-23 or PM-4	STATION C PM-2 & PM-3 or PM-23 or PM-4	TO OPERATE
2	48	200	200	—	—	PM-23 or PM-3
	125	3550	3550	—	—	"
	250	9300	9300	—	—	"
3	48	200	200	—	—	"
	125	2000	2000	—	—	"
	250	5600	5600	—	—	"

TABLE IIIA

**PMG-13 AND PM-13 (D.C. SUPPLY) APPLICATIONS
RESISTORS FOR D.C. REMOTE TRIPPING
(2 REQUIRED PER STATION)**

# LINE TERMINALS	D.C. VOLTAGE	STATION A PMG-13 or PM-13	STATION B PM-2 & PM-3 or PM-23 or PM-4	STATION C PM-2 & PM-3 or PM-23 or PM-4	TO OPERATE
2	48	200 †	200	—	PMG-13 or PM-13 and PM-23 or PM-3
	125	2120 †	2120	—	"
	250	5600 †	5600	—	"
3	48	200 †	200	200	"
	125	1500 †	1500	1500	"
	250	4000 †	4000	4000	"

† Mounted in Relay

TABLE IIIB

**PMG-13 AND PM-13 (A.C. SUPPLY) APPLICATIONS
(2 REQUIRED PER STATION)
RESISTORS FOR D.C. REMOTE TRIPPING**

# LINE TERMINALS	D.C. VOLTAGE	STATION A PMG-13 or PM-13	STATION B PM-2 & PM-3 or PM-23 or PM-4	STATION C PM-2 & PM-3 or PM-23 or PM-4	TO OPERATE
2	48	200 †	200	—	PMG-13 or PM-13 and PM-23 or PM-3
	125	2120 †	2120	—	"
	250	5600 †	5600	—	"
3	48	200 †	200	200	"
	125	1500 †	1500	1500	"
	250	4000 †	4000	4000	"

† Mounted in Relay

TABLE IV

NOMINAL CALIBRATION VALUES - TWO TERMINAL LINES

<u>RELAY</u>	<u>LOW CURRENT ALARM</u> ¹	<u>HIGH CURRENT ALARM</u> ²	<u>TRIP</u>
PMA or PMA-1	0.7 ma	1.3 ma	-
PMD or PMD-1	0.7	1.3	-
PM-5 †	-	±0.3	-
PMG-13 or PM-13	0.7 ††	1.3 ††	14 V.
PM-23 or PM-2 & PM-3 †	0.7	-	14 V.

† Same relay as for three-terminal lines
 †† These are pilot-wire current values

1 - Left-hand contacts, front view.
 2 - Right-hand contacts, front view.

TABLE V

NOMINAL CALIBRATION VALUES - THREE TERMINAL LINES

<u>RELAY</u>	<u>LOW CURRENT ALARM</u>	<u>HIGH CURRENT ALARM</u>	<u>TRIP</u>
PMA or PMA-1	1.7 ma	2.3 ma	-
PMD or PMD-1	1.7	2.3	-
PM-5 †	-	±0.3	-
PMG-13 or PM-13	1.7 ††	2.3 ††	14 V.
PM-23 or PM-2 & PM-3 †	0.7	-	14 V.

† Same relay as for two-terminal lines
 †† These are pilot-wire current values

Trip Circuit

The main contacts will safely close 30 amperes at 250 volts d-c and the seal-in contacts of the indicating contactor switch will safely carry this current long enough to trip a circuit breaker.

The indicating contactor switch has two taps that provide a pickup setting of 0.2 or 2 amperes. To change taps requires connecting the lead located in front of the tap block to the desired setting by means of a screw connection.

Trip Circuit Constant

Indicating Contactor Switch (ICS)

- 0.2 ampere tap 6.5 ohms d-c resistance
- 2.0 ampere tap 0.15 ohms d-c resistance

SETTING THE RELAY

Operating units of all relays are adjusted in the factory to the values listed in Tables IV and V to a tolerance of ±5%. No settings are required on these units.

For all 48/125-volt d.c. relays, connect jumpers across resistors as shown on the internal schematics.

PM-4, PM-2, and PM-23 Relays

Adjust the resistors in the PM-4, PM-2, or PM-23 relay or relays to a value of 1 MA d-c with the monitoring circuits connected for service. Use the milliammeter in the PM-23 for this purpose or use a portable milliammeter with a resistance of less than 200 ohms. Where it is not practical on three-terminal lines to adjust both receiving relays simultaneously, set one receiving relay for 18,000 ohms total resistance (including relay coil and resistors) by measurement prior to final adjustment of the other receiving relay. This procedure will minimize the change in monitoring current in the first relay to be adjusted when making the final adjustment of the second relay.

PMA, PMA-1, PMG-13 and PM-13 Relays

Select the transformer tap nearest to expected normal a-c supply voltage. The full wave rectifier is

connected to a secondary transformer tap. Where desired, the output voltage can be raised about 5% by reconnecting across the full secondary winding.

Indicating Contactor Switch

No setting is required on the ICS unit except the selection of the 0.2 or 2.0 ampere tap setting. This selection is made by connecting the lead located in front of the tap block to the desired setting by means of the connecting screw. When the relay energizes a type WL relay switch, or equivalent, use the 0.2 ampere tap.

INSTALLATION

The relays should be mounted on switchboard panels or their equivalent in a location free from dirt, moisture, excessive vibration, and heat. Mount the relay vertically by means of the four mounting holes on the flange for semi-flush mounting or by means of the rear mounting stud or studs for projection mounting. Either a mounting stud or the mounting screws may be utilized for grounding the relay. The electrical connections may be made directly to the terminals by means of screws for steel panel mounting or to the terminal studs furnished with the relay for thick panel mounting. The terminal studs may be easily removed or inserted by locking two nuts on the stud and then turning the proper nut with a wrench.

For detailed FT case information, refer to I.L. 41-076.

Where the potential to ground impressed on the relays can exceed 700 volts, a drainage reactor in conjunction with a KX-642 tube, or the reactor in conjunction with 700 volt carbon-block arresters, is recommended. For details, see Protection of Pilot-Wire Circuits, AIEE Committee Report, paper 58-1190, AIEE Transactions, 1959, Volume 78, Part III B pp. 205-212. Also, see AIEE Special Publication S-117, Applications and Protection of Pilot-Wire Circuits for Protective Relaying, July 1960.

ADJUSTMENTS AND MAINTENANCE

The proper adjustments to insure correct operation of this relay have been made at the factory and should not be disturbed after receipt by the customer. If the adjustments have been changed, the relay taken apart for repairs, or if it is desired to check the adjustments at regular maintenance periods, the instructions in the succeeding sections should be followed.

Acceptance Tests

The following tests are recommended when the relay is received from the factory. If the relay does not perform as specified below, the relay either is not properly calibrated or it contains a defect.

Indicating Contactor Switch (ICS)

Close the contact of the tripping unit and pass sufficient direct current through the trip circuit to close the contacts of the ICS unit. This value of current should not be greater than the particular ICS tap setting being used (0.2 or 2.0). The indicator target should drop freely.

PMA and PMA-1 Relays

Alarm Unit (1)

Set the primary tap on 120 volts. Connect a variable resistor of approximately 20,000 ohms in series with a low-range d-c milliammeter across terminals 6 and 7 with the instrument positive connected to terminal 7. Apply 120 volts at rated frequency to terminals 4 and 5. Adjust the 20,000-ohm resistor to obtain a current of one ma. d.c. For a three-terminal line relay, use a 10,000-ohm resistor and set the current to 2 ma. d.c. At this value, the moving contact of the alarm or monitoring relay unit (1) should float between the two sets of stationary contacts. In the PMA relay, the ground alarm unit (5) contact should also float. (This contact will also float when the relay is de-energized.) Increase and decrease the one or two-milliampere monitoring current to check the calibration values listed in Tables IV and V.

Ground Unit (5)

Reconnect the 20,000-ohm resistor. For the PMA relay only, short terminals 7 and 3. The contact of the ground alarm unit (5) should close to the right when the relay is energized. Remove the short, and connect it between terminals 6 and 3. The ground alarm unit (5) should close to the left. The action of the monitoring unit (1) contact is of no significance in this simulated pilot-wire ground test. To check the pickup current of the ground detector, first remove the 20,000-ohm resistor from terminals 6 and 7. Connect a 0-1 d.c. milliammeter in series with a variable resistor of about 50,000 ohms between terminals 3 and 6. The ground unit should close its left-hand contact at approximately 0.3 ma. d.c. With the milliammeter and resistor connected between terminals 3 and 7, the right-hand contact should close at 0.3 ma. d.c.

TYPE PM MONITORING RELAYS

PMD and PMD-1 Relays

Alarm and Ground Units

Connect an adjustable 20,000-ohm resistor (or 10,000-ohms for a 3-terminal relay) in series with a d-c milliammeter across terminals 6 and 7 with the instrument positive connected to terminal 7. Apply rated d-c voltage to terminals 8 and 9 with positive on terminal 9. Now check the PMD and PMD-1 relays, following the procedure given in the previous section for the PMA and PMA-1 relays, respectively. Note, however, that terminal 5 of the PMD relay corresponds to terminal 3 of the PMA relay.

PM-2, PM-3, and PM-23 Relays

Alarm Unit (2)

Apply a variable d-c voltage of approximately 20 volts to relay terminals 8 and 9 (terminal 9 positive) of the PM-2 or PM-23 relay. Adjust the voltage to obtain a reading of one ma. on the relay milliammeter. The monitoring polar unit (2) contacts should float. Reduce the current gradually. The monitoring alarm contacts should close at 0.7 ma. d.c. The tripping unit (3) of the PM-23 relay should not move during this test. The milliammeter has been adjusted to read 1 ma. $\pm 5\%$. As a result the pointer may not read zero for a zero current condition.

Tripping Unit (3)

To check the PM-3 relay or the tripping unit of the PM-23 relay, apply the variable d-c voltage in series with an external milliammeter to relay terminals 8 and 9 with terminal 8 positive for the PM-23 relay, or terminal 9 positive for the PM-3 relay. When checking the pickup of the PM-23 trip unit block open the alarm unit contacts (2) so as to remove the shunt resistor from around the trip coil (3).

The tripping relay unit (3) should pick up with positive action at 14 volts d.c. and should drop out at approximately 10 volts. The alarm unit of the PM-23 relay will not operate during this test.

PM-4 Relay

This device is simply a set of resistors and a diode to connect into the pilot-wire circuit to provide a path for the monitoring current. The resistors can be checked with an ohmmeter, and the diode can be checked either with an ohmmeter, or as explained in the section entitled "Rectifier Check" under "Routine Maintenance". If an ohmmeter is used, the difference in forward and reverse resistance readings obtained will be dependent on the current flowing through the diode.

PM-5 Relay

Apply 5 volts d.c. in series with a 0-1 d.c. milliammeter and a 20,000-ohm variable resistor to terminals 6 and 7 with positive on terminal 6. The left-hand contact should close at approximately 0.3 ma. Now apply the same circuit to terminals 8 and 9 with positive on terminal 9. The right-hand contact should close at approximately 0.3 ma.

PM 13 Relays - A.C. and D.C.

Alarm Unit (1)

Connect a variable 20,000-ohm resistor (10,000 ohms for a 3-terminal-line relay) in series with a d-c milliammeter across terminals 8 and 9 with the instrument positive on terminal 9. For the a-c relay, set the primary tap on 120 volts. Now apply the rated supply voltage to terminals 4 and 5. This will be 48, 125, or 250 volts d.c., or 120 volts a.c. as indicated on the relay nameplate. Adjust the variable resistor to obtain a current of one ma. for a 2-terminal line relay, or 2 ma. for a 3-terminal relay. At this value, the moving contacts of the alarm or monitoring (1) relay unit (the upper polar unit) should float between the two sets of stationary contacts. Increase and decrease the one or 2 ma. monitoring current to check the calibration values listed in Tables IV and V.

Tripping Unit (3)

To check the operation of the tripping unit 3 (the lower polar unit), apply a d.c. potential across terminals 16 (positive) and 20 (negative). The tripping polar unit should pick up at 14 volts, and should drop out at approximately 10 volts. The resistance of the series dropping resistors for transferred tripping (listed in Tables III A and III B) can be checked with an ohmmeter. The circuit location of these resistors can readily be seen from the external schematic, Figure 27.

PMG-13 Relays - A.C. and D.C.

Alarm and Tripping Units

Follow the procedure given in the previous section for the a-c. and d-c. PM-13 relays.

Ground Unit (5)

Connect the 20,000-ohm (or 10,000-ohm) resistor and milliammeter across terminals 8 and 9. With rated voltage applied and one ma. (or 2 ma.) flowing, successively short circuit terminals 3 and 8, then 3 and 9. The ground alarm unit 5 (lower polar unit) should move first to the left, then to the right. To check the pickup current of the ground detector, first remove the 20,000-ohm resistor from terminals 8 and 9. Connect a 0-1 d.c. milliammeter in series

with a variable resistor of about 50,000 ohms between terminals 3 and 8. The left-hand contact should close at approximately 0.3 ma. d.c. With the milliammeter resistor connected, between terminals 3 and 9, the right-hand contact should close at 0.3 ma. d.c. The external schematic diagrams for these relays are shown in Figure 23 and 25.

Routine Maintenance

CAUTION - Do not make any performance check, calibration tests, or adjustments while the PM relays are energized or connected to the pilot wires, to prevent the possibility of inadvertently causing a break operation. The PM relays may be removed from service for testing, without jeopardizing HCB relay protection, providing that the connections between the 10-mfd capacitor and the HCB insulating transformer are not disturbed.

Contacts

All contacts should be periodically cleaned. A contact burnisher S#182A836H01 is recommended for this purpose. The use of abrasive material for cleaning contacts is not recommended because of the danger of embedding small particles in the face of the soft silver and thus impairing the contact.

Operational Check

In addition to cleaning contacts, it is recommended that an operational check be performed periodically by opening and short-circuiting the pilot wires, as well as grounding them at the relay terminals. **Note:** These pilot-wire faults should not be applied directly to the pilot wires when the HCB relays are in service. It is also recommended that the trip circuits of the PM relays be opened (where tripping is used), to prevent the possibility of inadvertently tripping the associated circuit breaker during testing. If the relays do not perform as expected, and diode failure is suspected, the diode tests described in the following section may be performed.

Rectifier (Diode) Check

If there is suspicion of a rectifier (diode) failure, apply 30 volts d.c. reverse voltage (positive on arrowhead) through a 300-ohm resistance to the diode. Measure the voltage across the diode. If this voltage is not essentially 30 volts, the diode is short-circuited. Now apply 30 volts d.c. in the forward direction through the 300-ohm resistor, and measure the voltage across the resistor. If the voltage is not essentially 30 volts, the diode may have a high forward resistance. If the voltage is zero, the diode is open-circuited.

Calibration

If the relay has been dismantled or the calibration has been disturbed, use the following procedure for calibration.

With the permanent magnet removed, see that the moving armature floats in the central area of the air-gap between the poles of the polar unit frame. If necessary, loosen the core screw in the center rear of the unit and shift the core and contact assembly until the armature floats. (This can best be done with the polar unit removed from the relay.) Then retighten the core screw and replace the permanent magnet with the dimple (north pole) on the magnet to the left when viewed from the front.

Polar Units-General

The following mechanical adjustments are given as a guide, and some deviation from them may be necessary to obtain proper electrical calibration.

Magnetic Shunt Adjustment

The sensitivity of the polar unit is adjusted by means of two magnetic, screw-type shunts at the rear of the unit, as shown in Fig. 1. These shunt screws are held in proper adjustment by a flat strip spring across the back of the polar unit frame, so no locking screws are required. Looking at the relay, front view turning out the right-hand shunt to open the right-hand air gap decreases the amount of current required to close the right-hand contact. Conversely, drawing out the left-hand shunt increases the amount of current required to close the right-hand contact, or decreases the amount of current required to close the left-hand contact (with the proper direction of current flow). Also, if a relay trips to the right at the proper current, the dropout current can be raised by turning in the right-hand shunt. The two shunt-screw adjustments are not independent, however, and a certain amount of trimming adjustment of both shunt screws is generally necessary to obtain the desired pickup and dropout calibration.

In general, the farther out the two shunt screws are turned, the greater the toggle action will be, and as a result, the lower the dropout current. For the tripping units (3) of the PM-3, PM-13, and PM-23 relays, toggle action is desirable, with a dropout current around 75 percent of the pickup current. For the monitoring alarm relay units, toggle action is not desired. Instead, the armature is adjusted to float between the pole faces at a given current (1 or 2

TYPE PM MONITORING RELAYS

The following chart indicates the units present in each relay.

FUNCTION AND UNIT	PMA PMD	PMA-1 PMD-1	PM2	PM3	PM4	PM5	PM13	PMG13	PM23
Alarm for p.w. open, short or reversal (1) (2)	X	X	X				X	X	X
Transfer-Trip Unit (3)				X			X	X	X
Alarm for p.w. ground (5)	X					X		X	
D.C. Path for Monitoring Current					X				

ma.), and to move gradually toward the high or low-current alarm as the coil current is increased or decreased. Similarly, the floating adjustment of the armature of the ground alarm unit (5) requires that both shunt screws be turned in relatively far. Then the armature will move gradually to the left or right as the current through the two #5 coils is unbalanced.

The electrical calibration of the polar unit is also affected by the contact adjustment as this changes the position of the polar unit armature. Do not change the contact adjustment without rechecking the electrical calibration.

Contact Adjustment - All Relays

For all monitoring alarm units, designated (1) or (2), turn in all the stationary contact and contact stop screws until they just touch the moving contact. Advance the screws to hold the armature in the central portion of the magnetic air gap between the two pole faces. (The stationary contact screws have a round silver contact face; the stop screws do not have this silver facing.) Now back off all the contact and contact stop screws one full turn. This will give a total contact travel of 0.050 inch. When the relay is properly calibrated, some touch-up adjustment may be necessary so that double contacts will both close at the same current value. The contact gap between the floating moving contact and the right-hand or left-hand stationary contacts or contact stops will be approximately 0.025 inch when the relay is in operation.

For the tripping (3) units of the PM-3, PM-13, PMG-13, and PM-23 relays, adjust the contacts as described in the previous paragraph, except back off the contact and stop screws one-half turn each to

give a total moving contact travel of approximately 0.025 inch. In operation of the tripping unit, the moving contact will normally rest against the contact stop screws, and will pick up only for a transferred-tripping operation.

For the pilot-wire ground alarm unit (5) of the PMA, PMD, PM5, and PMG-13 relays, follow the same general procedure except back off both stationary contact screws two turns each. This will give a contact gap of 0.050 on each side of the moving contact when it is its normal central position.

Electrical Calibration - All Relays

In the following sections, the calibration instructions are given for the polar unit which performs a certain function, such as alarm (1) or (2), ground (5), or trip (3), rather than giving calibration instructions for each complete relay. In this way, considerable duplication of instructions has been eliminated.

Alarm Unit (1)

Connect the relay as described under Acceptance Tests for the particular relay involved. Screw the two magnetic shunts all the way in, then back them out five turns each. With the relay energized at rated voltage, set the monitoring current at 1.3 or 2.3 ma. d.c. for 2 or 3-terminal relay respectively, by adjusting the external resistor. If the relay does not close its right-hand contact, turn in the left shunt screw until the right-hand contact just closes. If the right-hand contact is closed at 1.3 ma., turn in the right shunt until a point is reached when the right-hand contact is just closed at 1.3 ma.

Now drop the current to 0.7 ma. and adjust the opposite shunt until the left-hand contact just closes

at 0.7 ma. d.c. At 1.0 ma. d.c., the moving contact should float half way between the two sets of stationary contacts with a 0.025-inch gap on each side. Recheck the high and low current calibration several times, touching up the shunt adjustments as required to obtain the desired calibration.

Polarization Check

For all the source relays, which are listed below, make the following additional calibration check:

- PMA PM-13 (a.c. and d.c.)
- PMA-1 PMG-13 (a.c. and d.c.)
- PMD
- PMD-1

After calibration as described in the previous sections, connect a 20,000 ohm resistor (or 10,000 ohms for 3-terminal applications) across the output terminals, and energize the relay at its rated supply voltage. With these connections, approximately one (or two) milliamperes d.c. will flow through the monitor relay coils and external resistor, thus representing normal operating conditions.

Now momentarily (one second or so) apply 48 volts d.c. directly to the pilot-wire terminals of the relay, as indicated in the following table.

Relay	Terminals for Momentary Application of 48 V. d.c.	
	POS.	NEG.
PMA, PMA-1 } PMD, PMD-1 }	6	7
PM-13 (a.c. or d.c.) } PMG-13 (a.c. or d.c.) }	8	9

After momentary application of the transfer-trip voltage as just explained, recheck the calibration of the monitoring alarm unit (1). If it has changed, make necessary trimming adjustments of the shunt screws until there is no change in calibrating of the alarm unit (1) after the transfer-trip voltage has been applied. The purpose of this test is to compensate for the small residual magnetism in the relay unit. The ground alarm unit (5) will not be affected by this test as the ampere-turns of the two windings cancel each other.

Alarm Unit (2)

For the alarm unit of the PM-2 or PM-23 relays, adjust the shunts so that the relay moving contact

floats at one ma. d.c., and closes the left-hand contact at 0.7 ma. d.c. The moving contact should float midway between the contact and contact stop at 1.0 ma. d.c. There is no high-current calibration for this relay unit.

Now apply 48 volts d.c. momentarily (one second or so) across the alarm unit coil-circuit terminals in a direction to operate the alarm relay. Then recheck the alarm unit calibration. If there is any change, touch up the shunt adjustments until there is no change in calibration after 48 v. d.c. has been applied.

Tripping Unit (3)

To calibrate the tripping unit of the PM-3, PM-13, PMG-13, or PM-23 relays apply a d.c. voltage as explained below, to the following relay terminals:

Relays	D.C.	Voltage
	Pos.	Neg.
PM-3	9	8
PM-13 (a.c. or d.c.)	16	20
PMG-13 (a.c. or d.c.)	8	9
PM-23	8	9

Momentarily (one second or so) apply 48 volts d.c. to the terminals shown in the chart. Then starting with both shunts all the way in, turn out the right-hand shunt screw until the relay closes its right-hand trip contact at 14 volts d.c. (This will give approximately 2 ma. through the relay coil.) Now draw out the left-hand shunt until the relay resets with toggle action (not gradually) at not less than 10 volts d.c. When the calibration is approximately correct, again apply 48 volts d.c. to the indicated terminals, then recheck the pickup and dropout voltage, making any necessary trimming adjustments of the shunts. When the relay is properly adjusted, the application of 48 volts.d.c. will not change the pickup or dropout voltage points. The relay should trip and reset with toggle action in this application. This will require both shunt screws to be withdrawn farther than for floating action.

Ground Alarm Unit (5)

For the PM-5 relay, turn both shunt screws all the way in, then back them out five turns each. Pass a current of 0.3 ma. d.c. in terminal 6 and out terminal 7. Following the same general procedure as described previously in the section entitled "Alarm Unit (1)," adjust the shunt screws so that the left-hand contact closes at 0.3 ma. Now pass 0.3 ma. d.c.

TYPE PM MONITORING RELAYS

in terminal 9 and out terminal 8, and adjust for closing of the right-hand contact at 0.3 ma. Recheck both pickup points several times, and make trimming adjustments of both shunts as required to obtain contact closing at 0.3 ma. d.c. in each direction.

For the ground unit (5) of the PMA, PMD, and PMG-13 relays, connect a variable resistance of about 50,000 ohms in series with a 0-1 d.c. milliammeter between the terminals indicated in the following table:

Turn the shunts all the way in, then back them out five turns each. With the relay connected as shown in the left-hand column of the table, apply rated voltage to the relay and adjust the 50,000-ohm resistor for 0.3 ma. d.c. Now following the procedure in the previous paragraph for the PM-5 relay, adjust the shunts until the left-hand contact closes at 0.3 ma. d.c. Change the connections as indicated in the right-hand column, and adjust the opposite shunt until the right-hand contact closes. Recheck back and forth several times and make necessary trimming adjustments to obtain pickup at 0.3 ma. In each direction. The armature will move gradually as the

current is changed for this relay unit.

ICS Unit

Close the main relay tripping contact circuit with a jumper connected directly across the contact terminals of the polar unit. Pass sufficient direct current through the relay trip circuit to close the contacts of the ICS unit. This value of current should not be greater than the ICS tap setting being used (0.2 or 2.0). The indicator target should drop freely. The contact gap should be approximately 0.047 inch between the bridging moving contact and the adjustable stationary contacts. The bridging moving contact should touch both stationary contacts simultaneously.

RENEWAL PARTS

Repair work can be done most satisfactorily at the factory. However, interchangeable parts can be furnished to the customers who are equipped for doing repair work. When ordering parts, always give the complete nameplate data.

Ground Alarm (5) Calibration		
Relay	<u>Relay Terminals</u>	
	L.H. Contact Check	R.H. Contact Check
PMA	3 ⁺ and 6	3 and 7 ⁺
PMD	5 ⁺ and 6	5 and 7 ⁺
PMG-13	3 ⁺ and 8	3 and 9 ⁺

+ Milliammeter positive to this terminal

INDEX TO FIGURES

INTERNAL SCHEMATICS

FIG. NO.		PAGE NO.
1	Polar Unit Permanent Magnet Flux Paths	2
2	PMA Relay - AC supply - two terminal line	14
3	PMA-1 Relay - AC supply - two terminal line	14
4	PMA Relay - AC supply - three terminal line	14
5	PMA-1 Relay - AC supply - three terminal line	14
6	PMD Relay - DC supply - two terminal line	15
7	PMD-1 Relay - DC supply - two terminal line	15
8	PMD Relay - DC supply - three terminal line	15
9	PMD-1 Relay - DC supply - three terminal line	15
10	PM-2 relay in FT21 case	16
11	PM-3 relay in FT11 case	16
12	PM-4 relay (auxiliary unit)	16
13	PM-5 ground detector relay	16
14	PM-23 relay in FT21 case	17
15	PM-13 Relay - DC supply - two terminal line	17
16	PM-13 Relay - DC supply - three terminal line	17
17	PM-13 Relay - AC supply - two or three terminal line	17
18	PMG-13 Relay - DC supply - two terminal line	18
19	PMG-13 Relay - DC supply - three terminal line	18
20	PMG-13 Relay - AC supply - two or three terminal line	18

EXTERNAL SCHEMATICS

21	PMD relay with telephone relay PM-23 or PM-4, two terminal line	19
22	PMA relay with PM-23 or PM-4, two terminal line	19
23	DC type PMG-13 with telephone relay PM-23 or PM-4, two terminal line	20
24	PMD relay with telephone relay PM-23 and PM-4, three terminal line	20
25	AC type PMG-13 relay with PM-23, two terminal line	21
26	DC type PM-13 and PM-5 with PM-23 or PM-4, two terminal line	21
27	DC type PM-13 relay with PM-23 or PM-4, two terminal line	22

OUTLINE & DRILLING PLANS

28	10 mfd. capacitor	23
29	Remote trip resistor	23
30	PM-4 projection molded case	23
31	PM-4 semi-flush molded case	23
32	PM-3, PM-5, & PMD-1 in FT11 case	24
33	PM-2, PM-23, PMA-1, & PMD in FT21 case	25
34	PMA in FT31 case	26
35	PM-13 and PMG-13 in FT32 case	27

TYPE PM MONITORING RELAYS

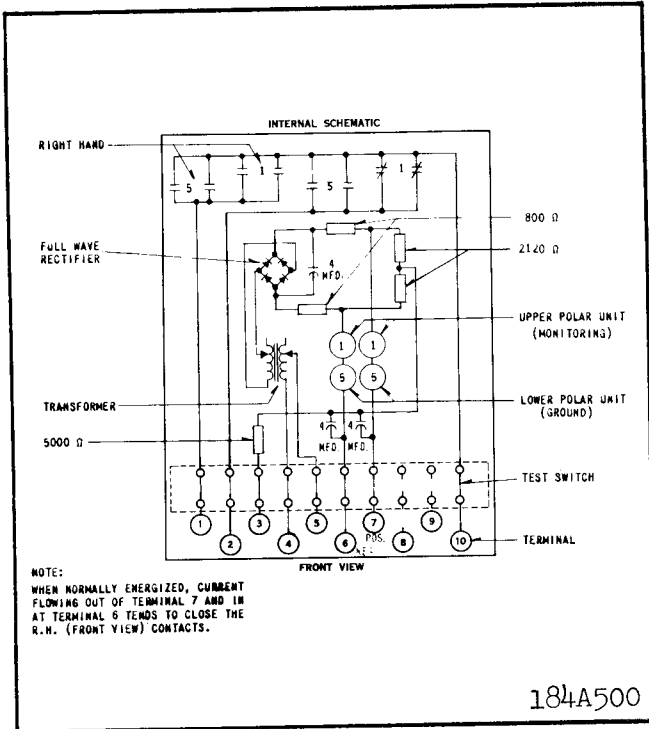

Fig. 2. Internal schematic of the type PMA relay in FT 31 case - 120 volt, 60 cycle supply - For two terminal lines.

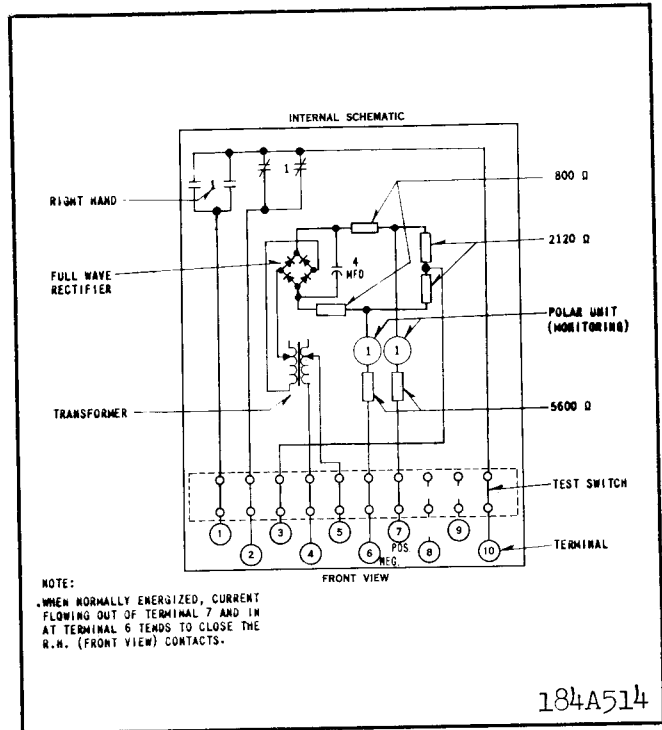

Fig. 3. Internal schematic of type PMA-1 relay in the FT 21 case - 120 volts, 60 cycle supply - For two terminal lines.

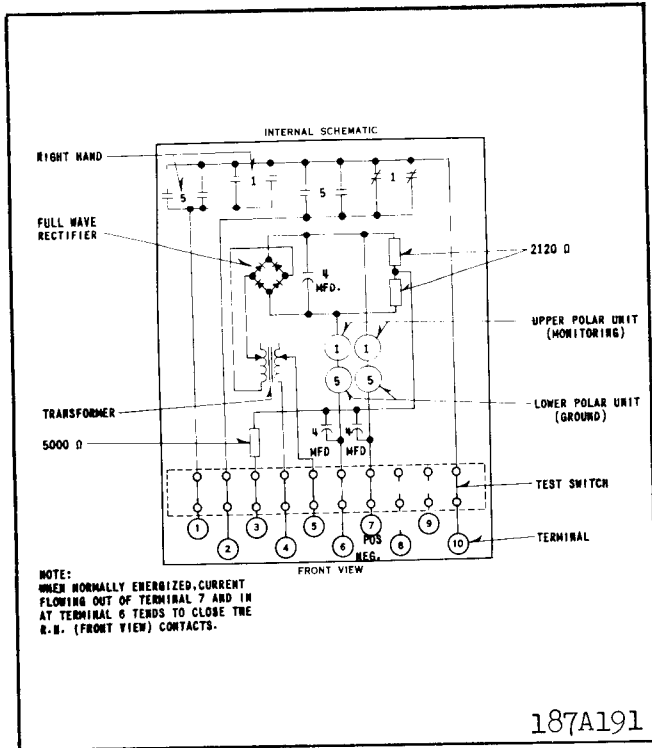

Fig. 4. Internal schematic of type PMA relay in FT 31 case - 120 volt, 60 cycle supply - For three terminal lines.

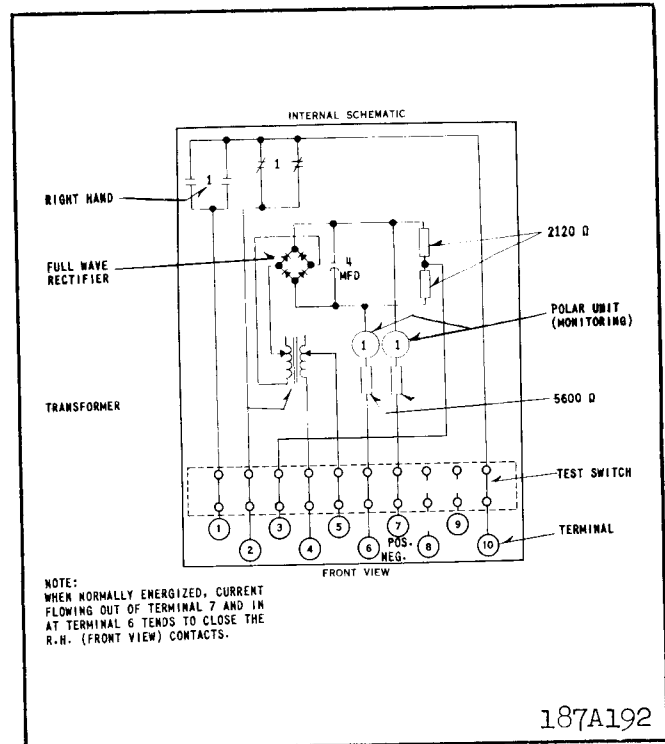

Fig. 5. Internal schematic of type PMA-1 relay in FT 21 case - 120 volt, 60 cycle supply - For three terminal lines.

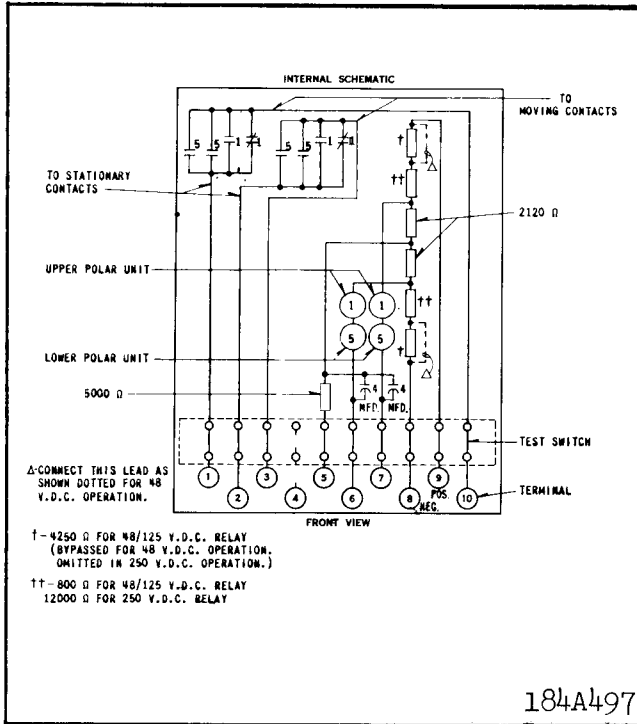

Fig. 6. Internal schematic of the type PMD relay in FT 21 case - DC supply - for two terminal lines.

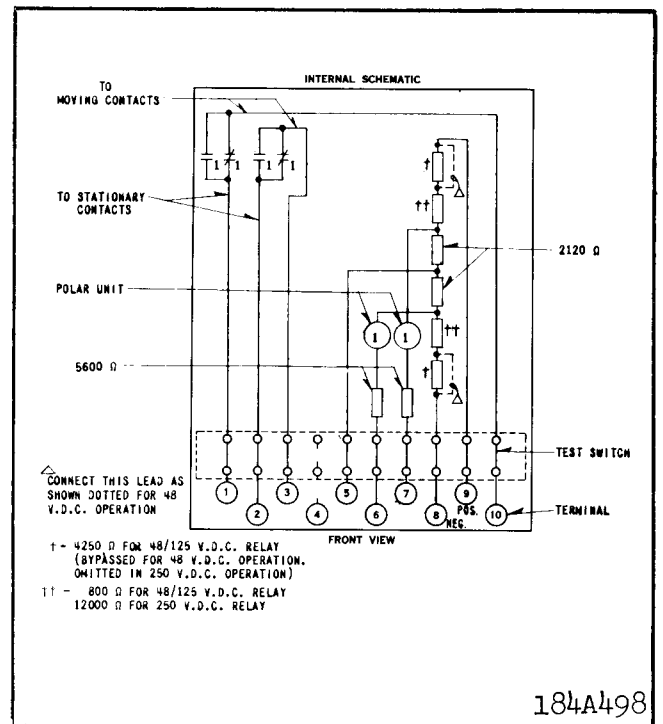

Fig. 7. Internal schematic of the type PMD-1 relay in the FT 11 case - DC supply - For two terminal lines.

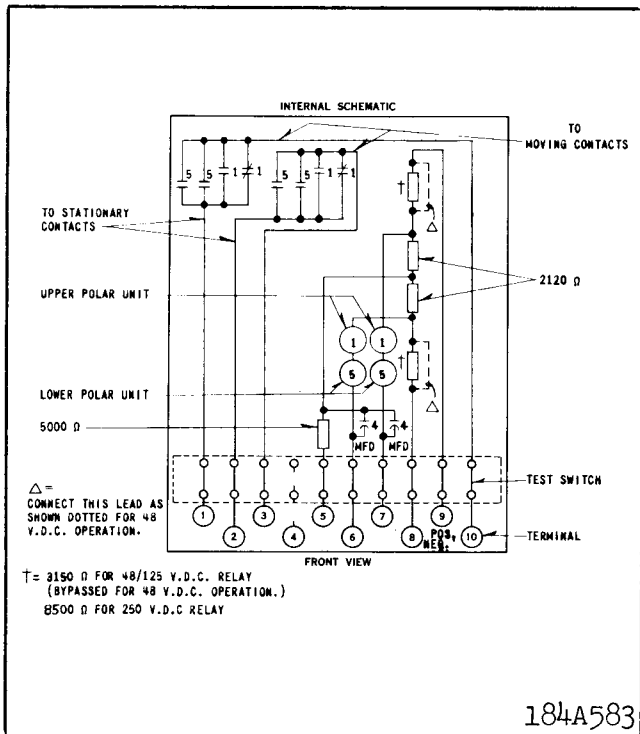

Fig. 8. Internal schematic of the type PMD relay in the FT 21 case - DC supply - For three terminal lines.

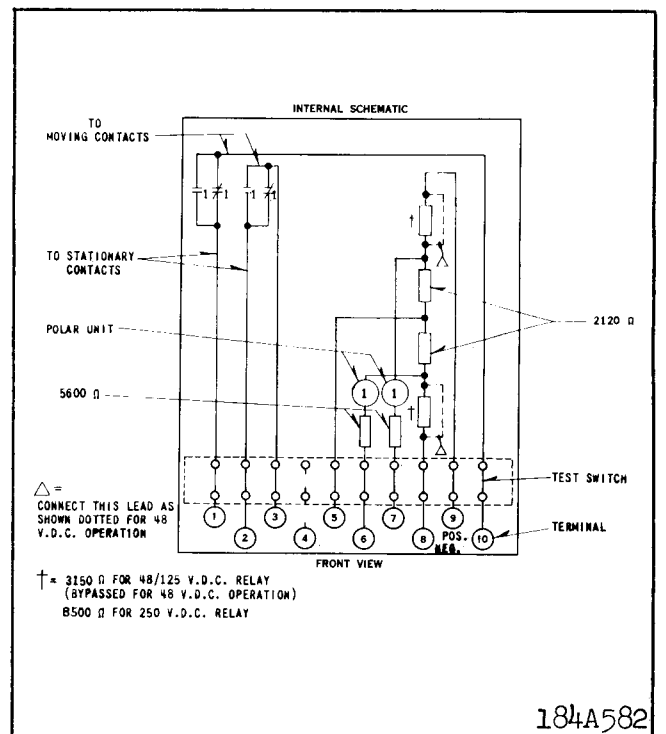

Fig. 9. Internal schematic of the type PMD-1 relay in the FT 11 case - DC supply - For three terminal lines.

TYPE PM MONITORING RELAYS

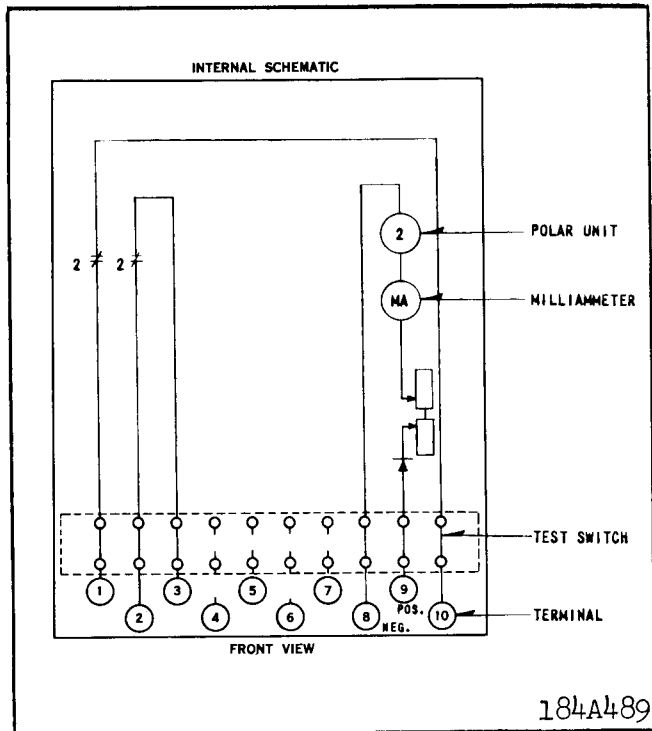

Fig. 10. Internal schematic of the type PM-2 relay in the FT 21 case.

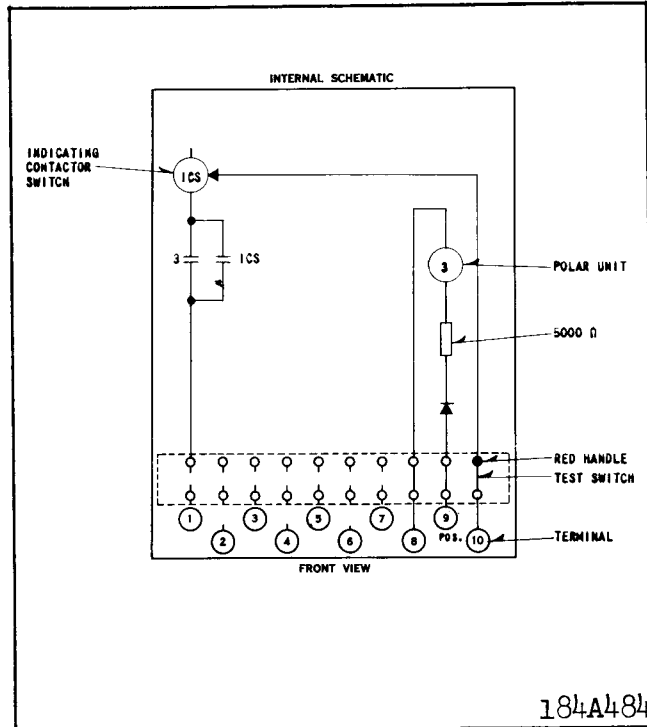

Fig. 11. Internal schematic of the type PM-3 relay in the FT 11 case.

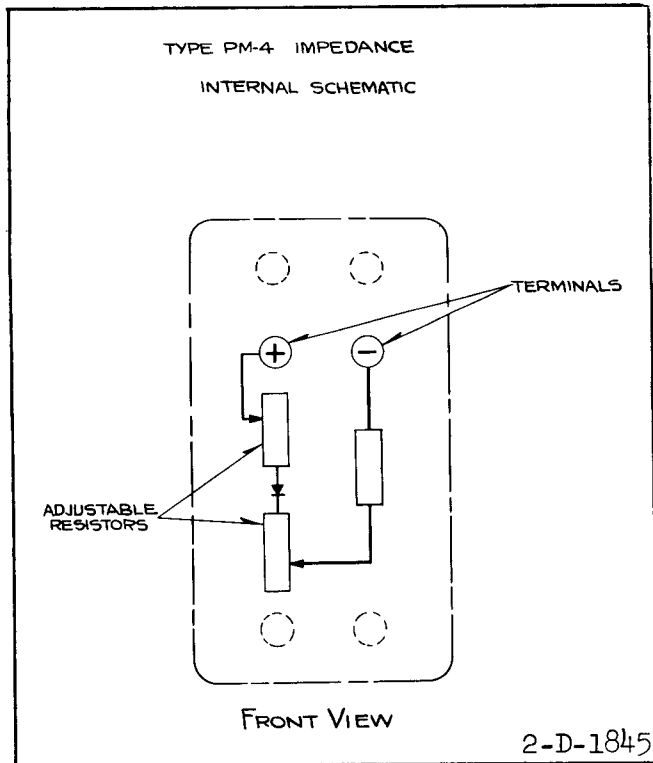

Fig. 12. Internal schematic of the type PM-4 Auxiliary Unit in the small molded case.

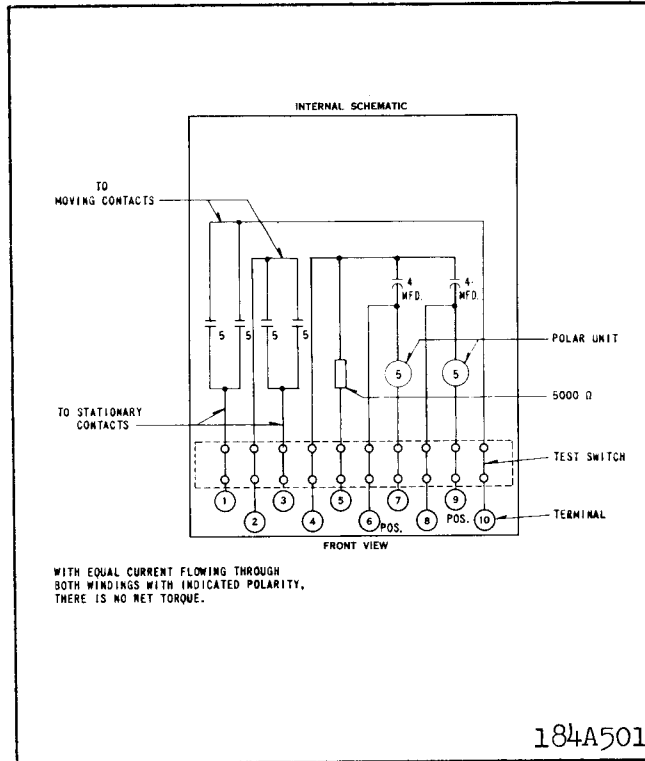

Fig. 13. Internal schematic of the type PM-5 ground detector relay in the FT 11 case.

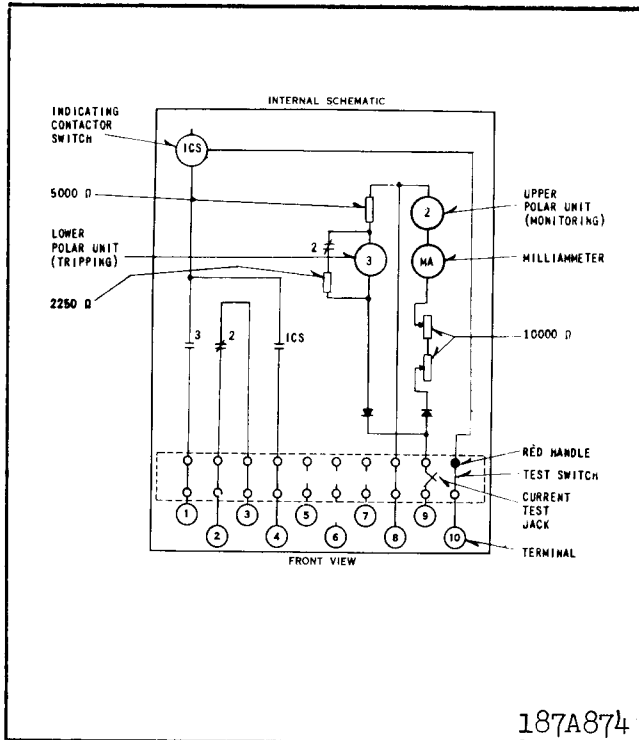

Fig. 14. Internal schematic of the type PM-23 relay in the FT 21 case.

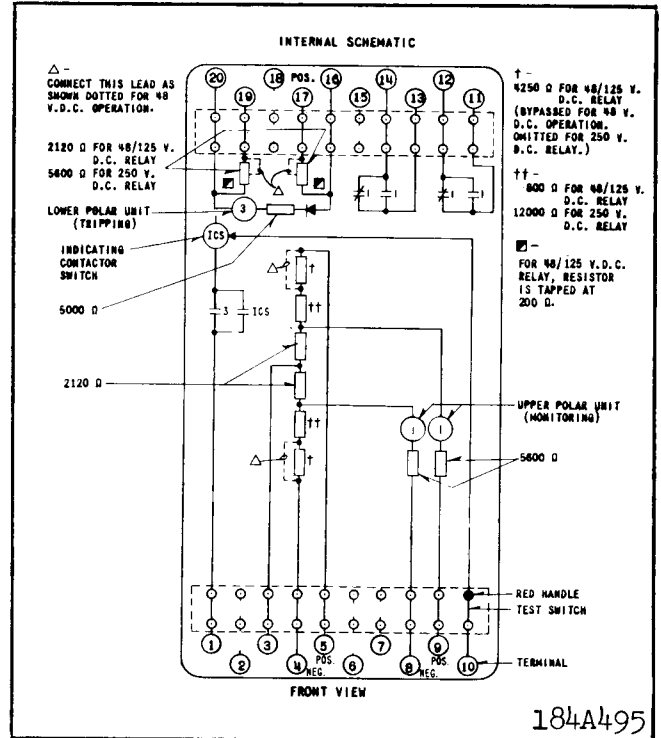

Fig. 15. Internal schematic of the type PM-13 relay in the FT 32 case - DC supply - For two terminal lines.

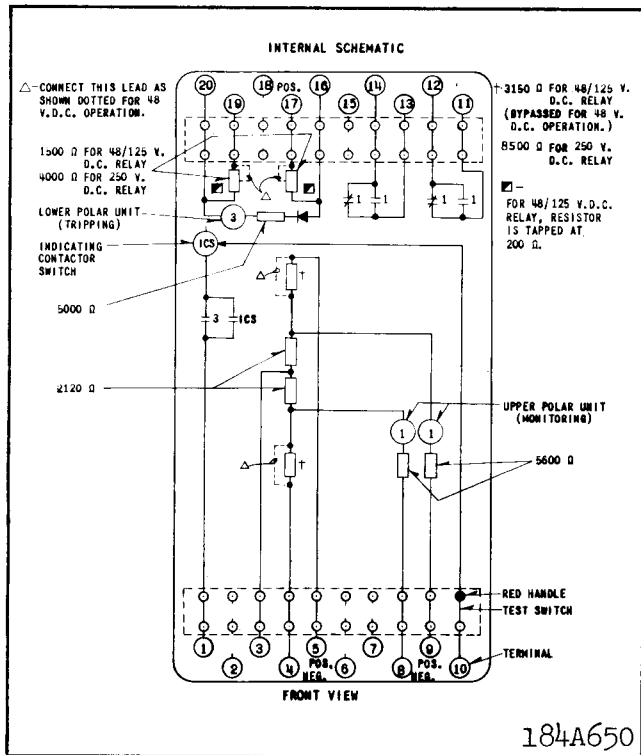

Fig. 16. Internal schematic of the type PM-13 relay in the FT 32 case - DC supply - For three terminal lines.

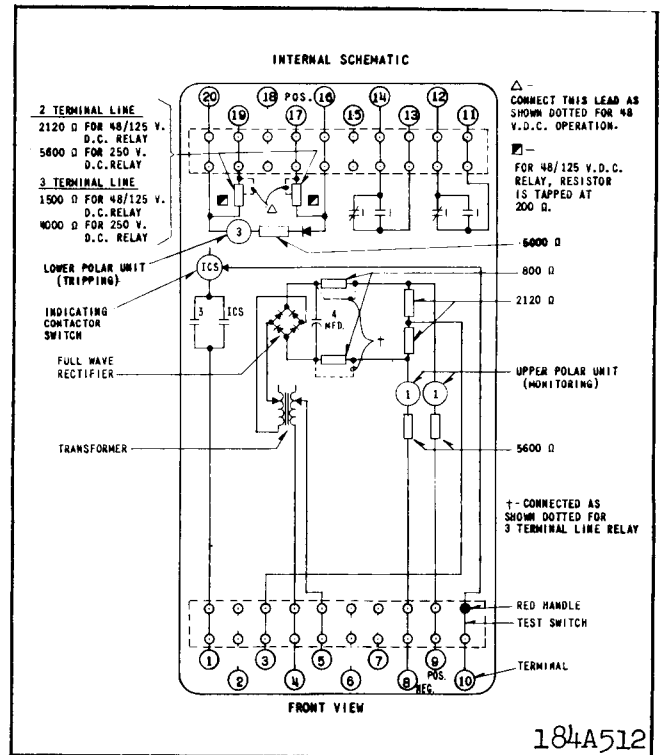

Fig. 17. Internal schematic of the type PM-13 relay in the FT 32 case - 120 volt, 60 cycle supply - For two or three terminal lines.

TYPE PM MONITORING RELAYS

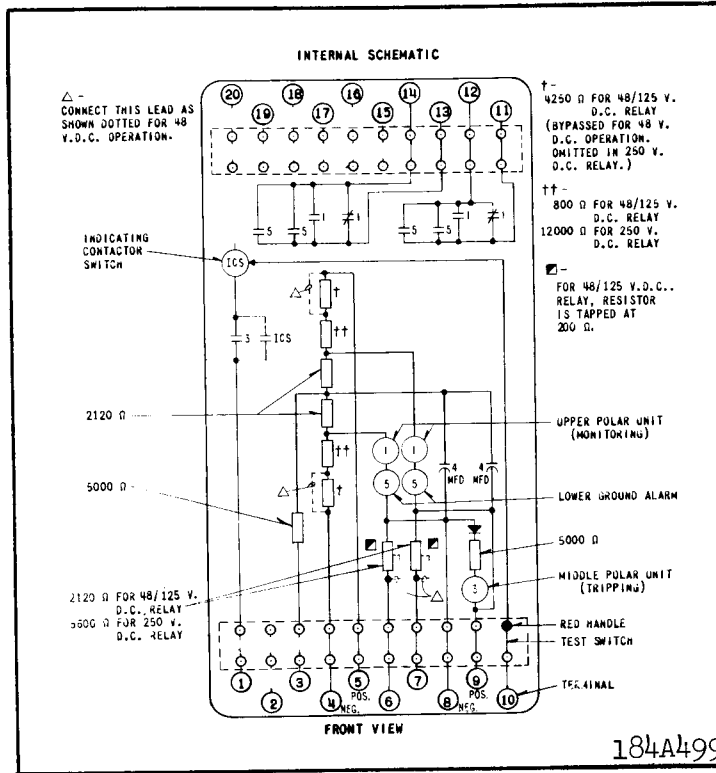

Fig. 18. Internal schematic of the type PMG-13 relay in the FT 32 case - DC supply - For two terminal lines.

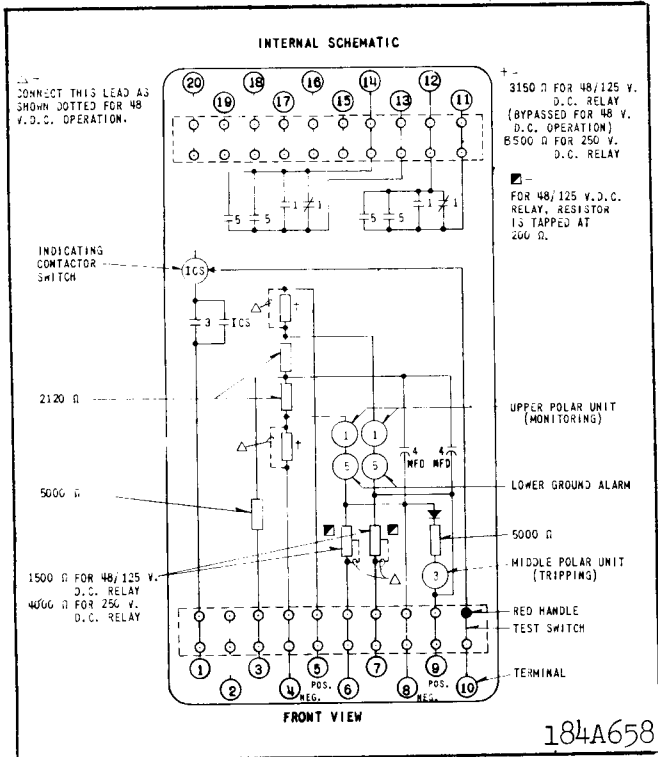

Fig. 19. Internal schematic of the type PMG-13 relay in the FT 32 case - DC supply - For three terminal lines.

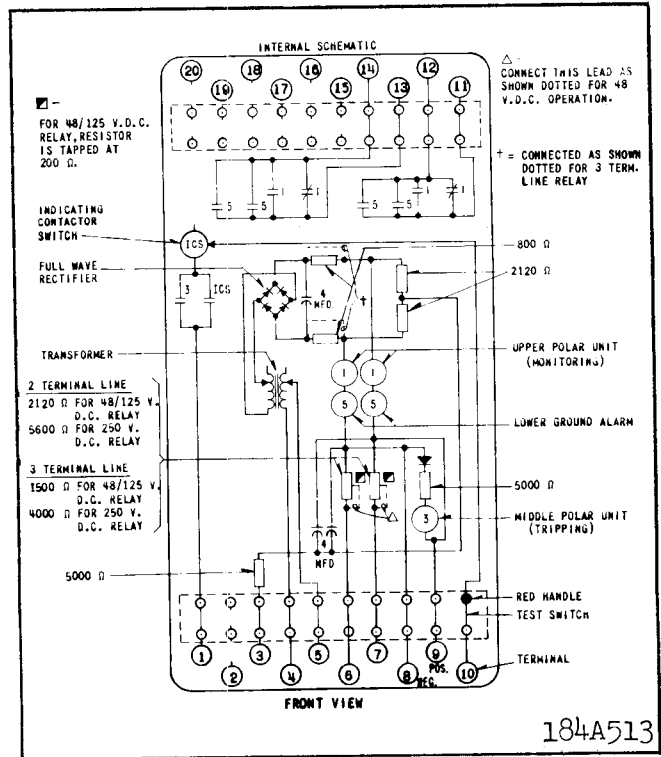

Fig. 20. Internal schematic of the type PMG-13 relay in the FT 32 case - 120 volt, 60 cycle supply - For two or three terminal lines.

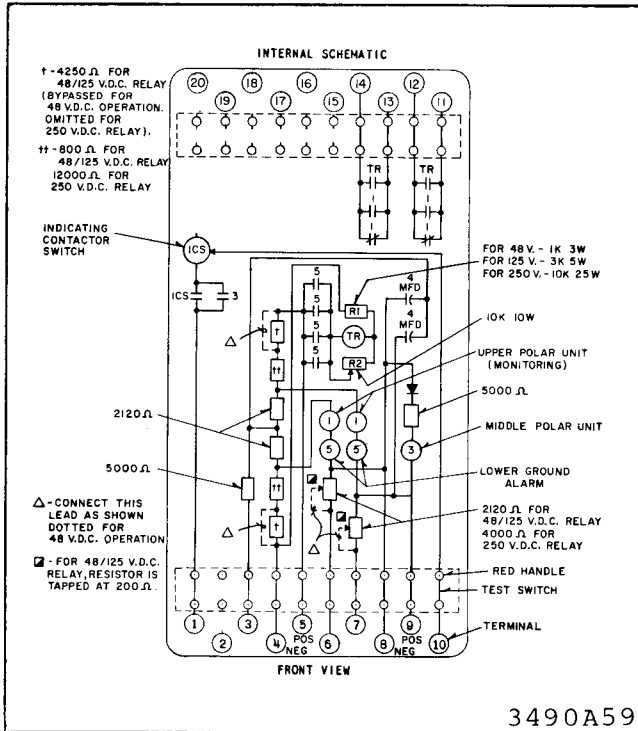

Fig. 21. PMG-13 Relay with Ground Alarm and Remote Trip - Two Terminal Lines with Telephone Relay Output. FT-32 Case.

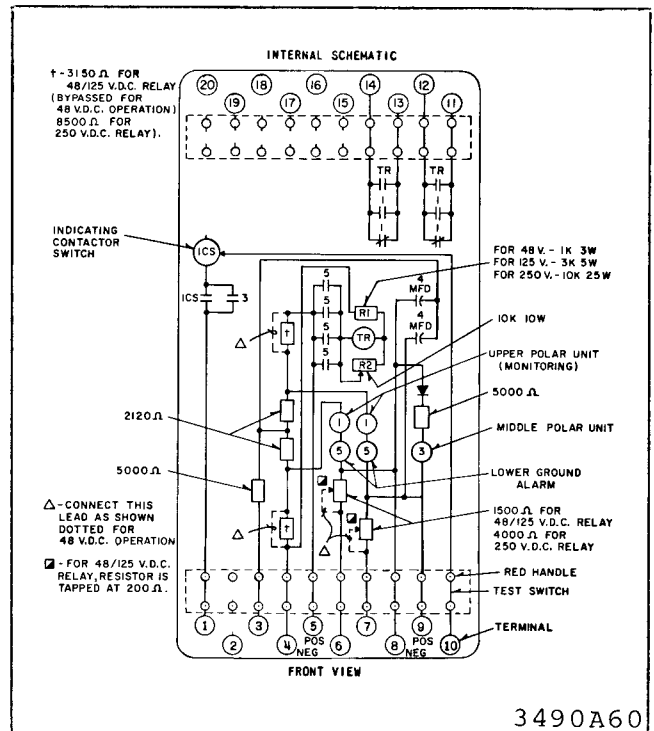
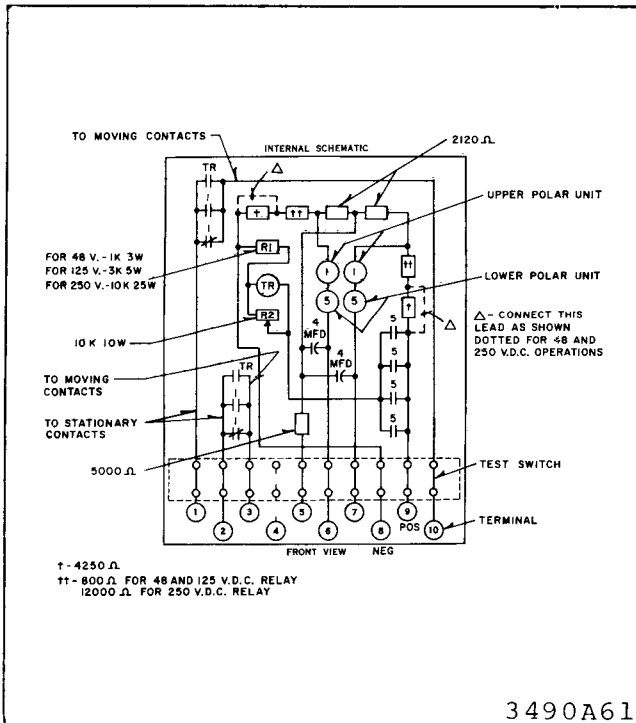
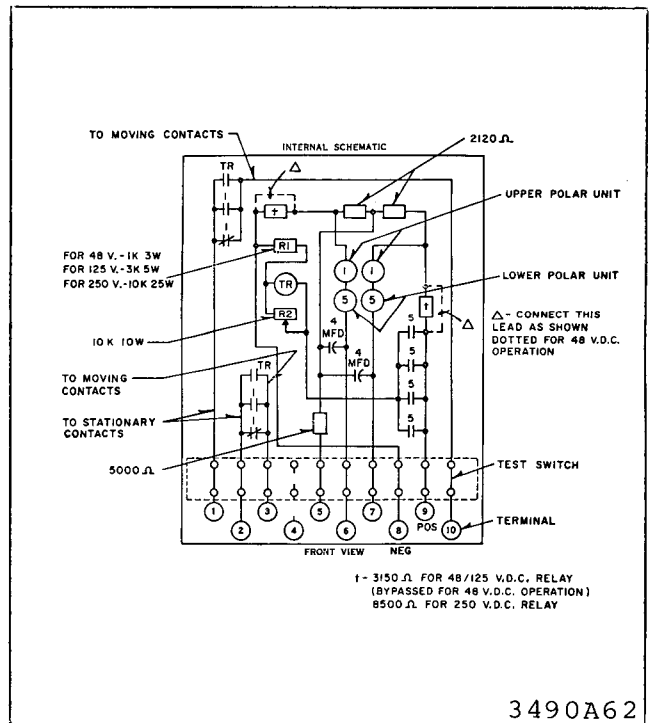

Fig. 22. PMG-13 Relay with Ground Alarm and Remote Trip - Three Terminal Lines with Telephone Relay Output - FT-32 Case.



* Fig. 23. PMD Relay - Ground Alarm, D.P.D.T. Contacts, Two Terminal Lines with Telephone Relay Output - FT-21 Case.



* Fig. 24. PMD Relay - Ground Alarm, D.P.D.T. Contacts, Three Terminal Lines with Telephone Relay Output - FT-21 Case.

TYPE PM MONITORING RELAYS

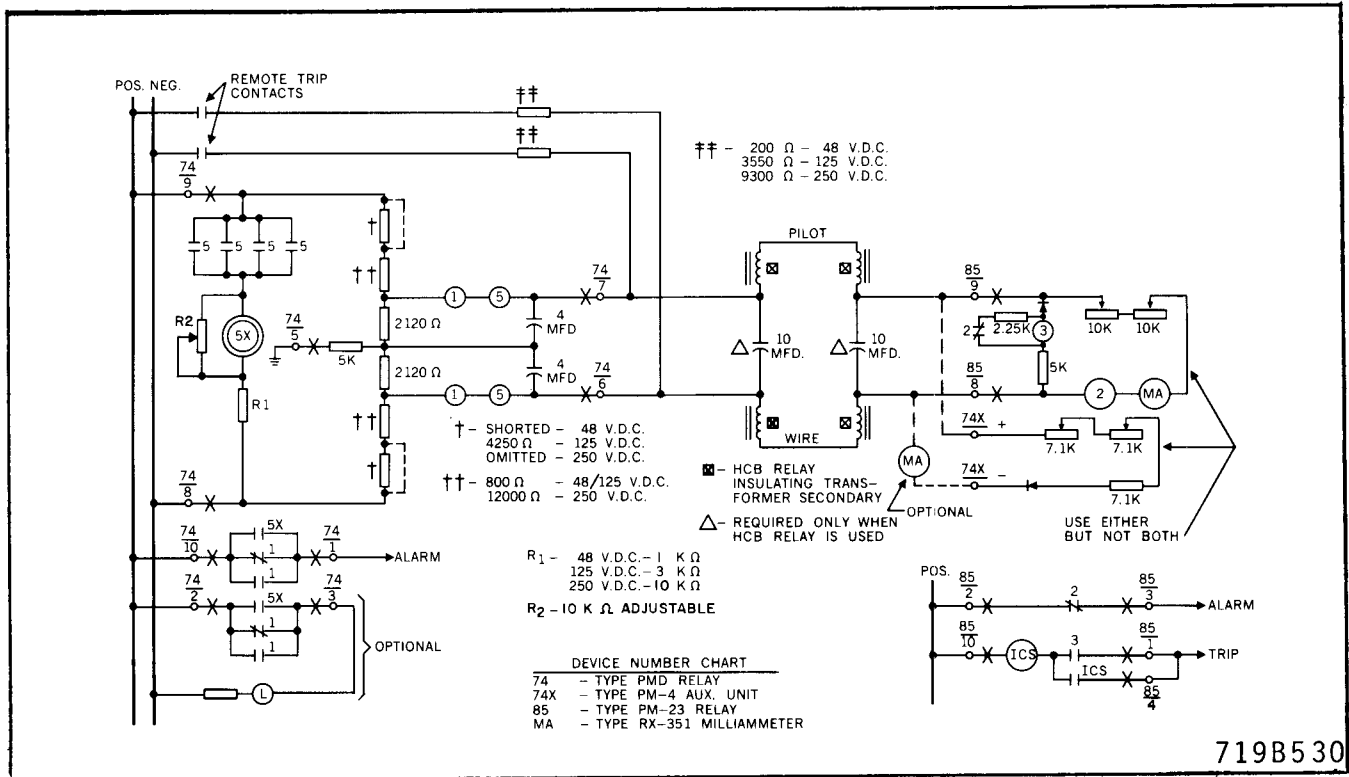

* Fig. 25. External schematic of the type PMD relay with type PM-23 or PM-4 relay - Two terminal lines.

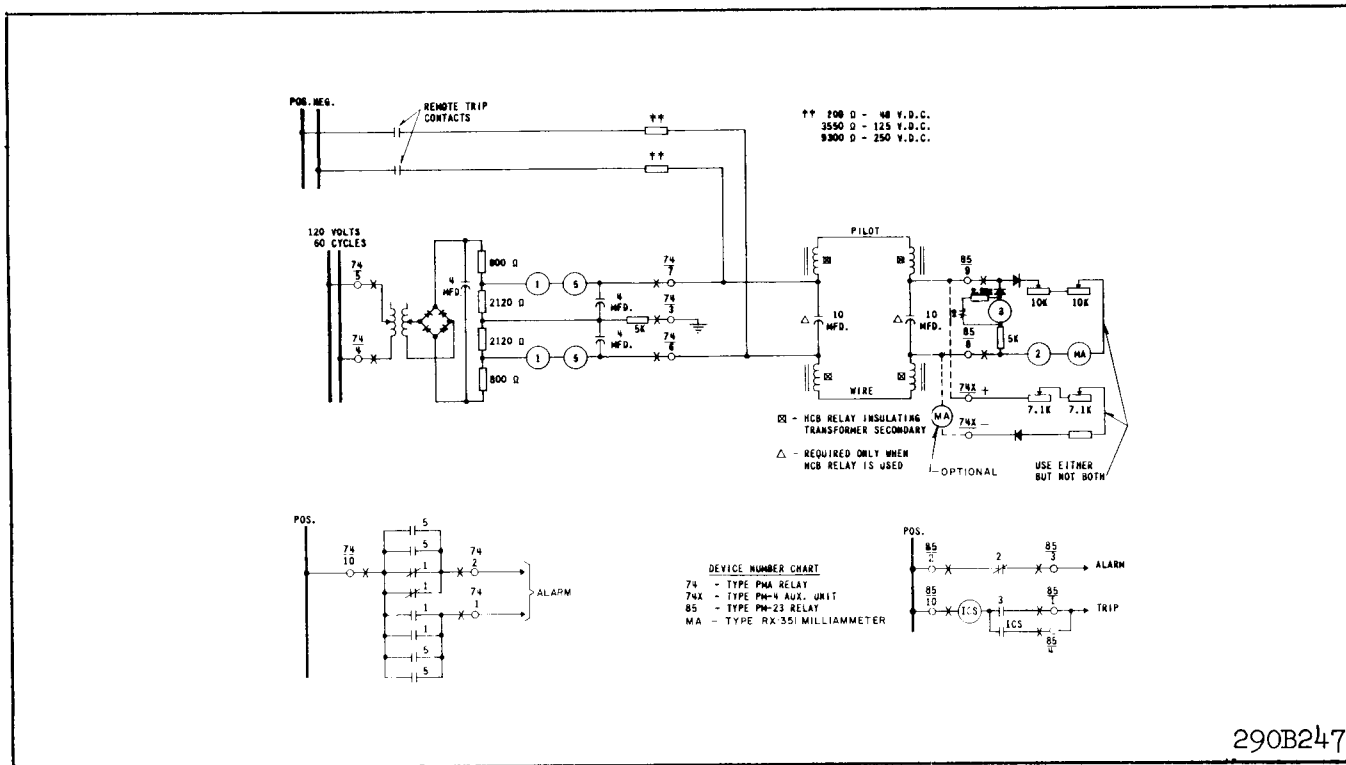
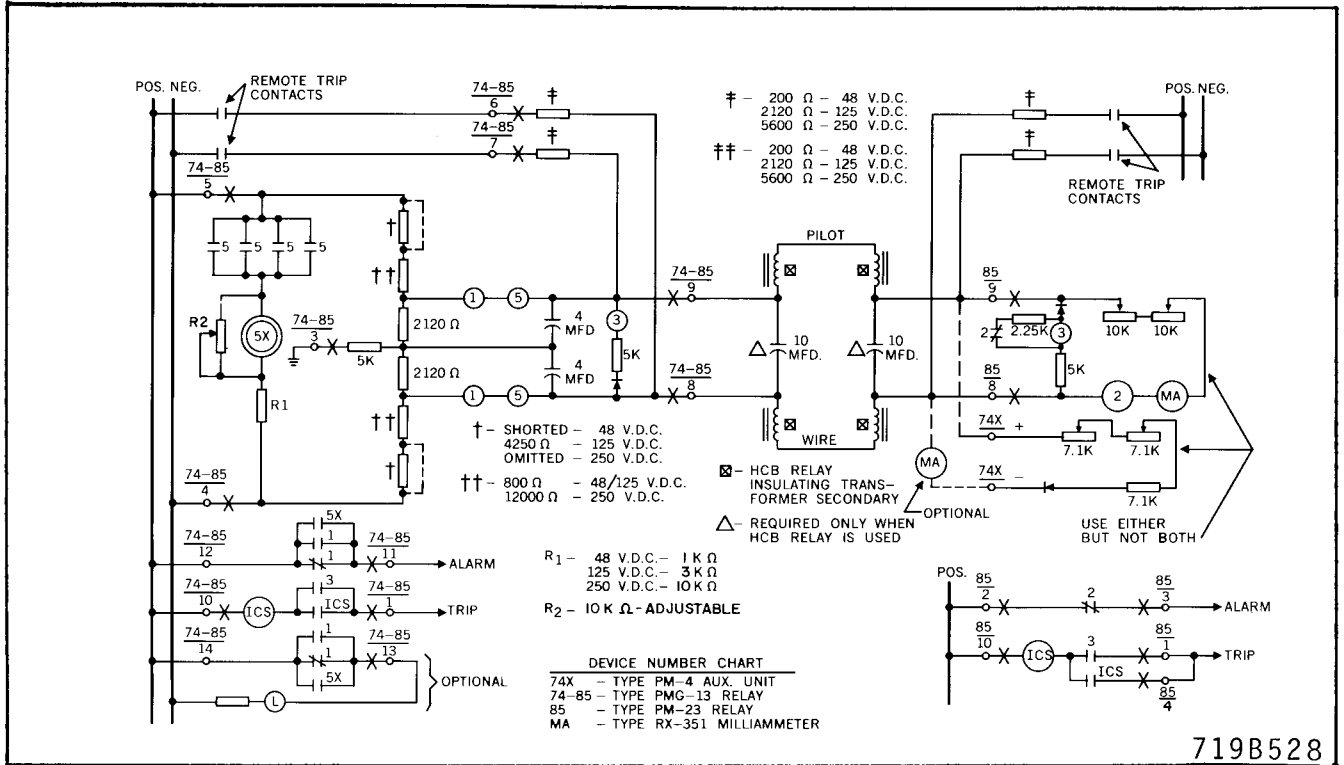
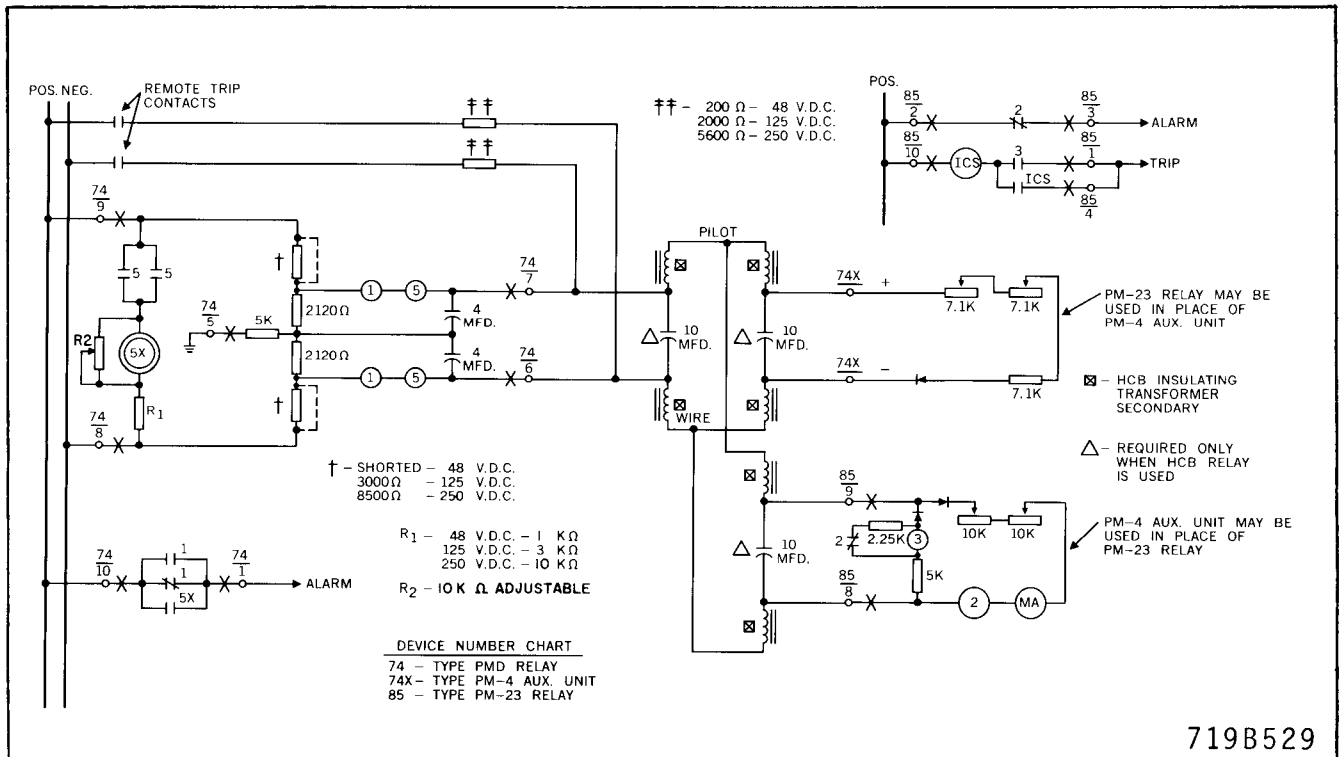

Fig. 26. External schematic of the type PMA relay with type PM-23 or PM-4 relay - Two terminal lines.



* Fig. 27. External schematic of the DC type PMG-13 relay with type PM-23 or PM-4 relay - Two terminal lines.



* Fig. 28. External schematic of the type PMD relay with type PM-23 and PM-4 relays - Three terminal lines.

TYPE PM MONITORING RELAYS

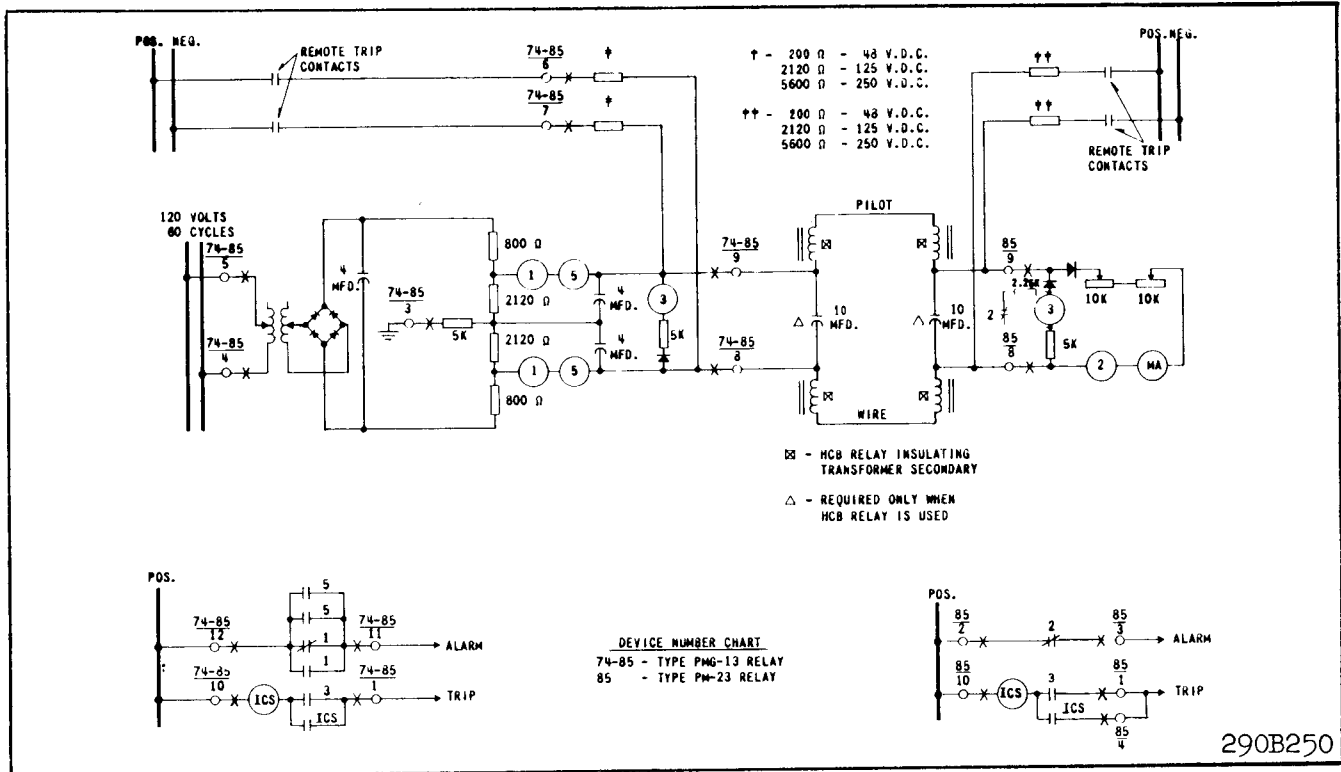

Fig. 29. External schematic of the AC type PMG-13 with type PM-23 relay - Two terminal lines.

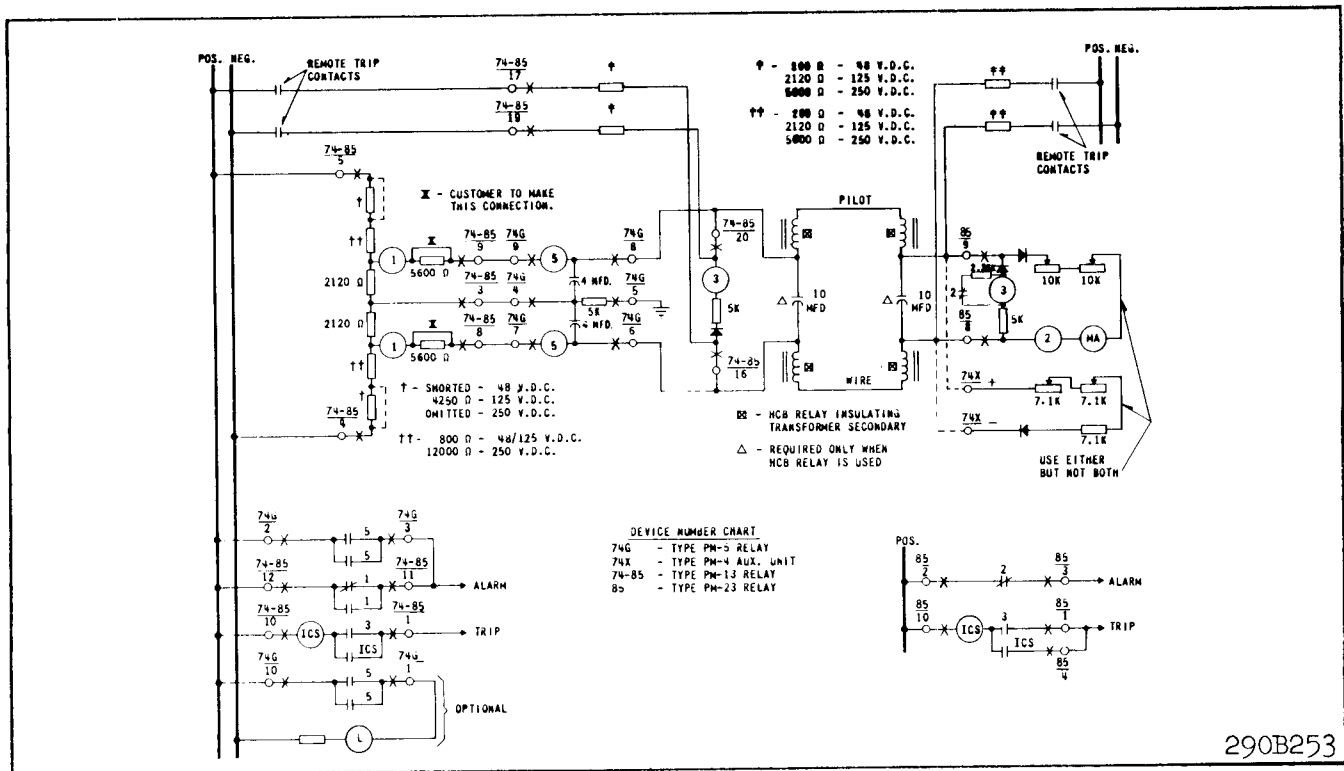

Fig. 30. External schematic of the DC type PM-13 and PM-5 relay with type PM-23 or PM-4 relay - Two terminal lines.

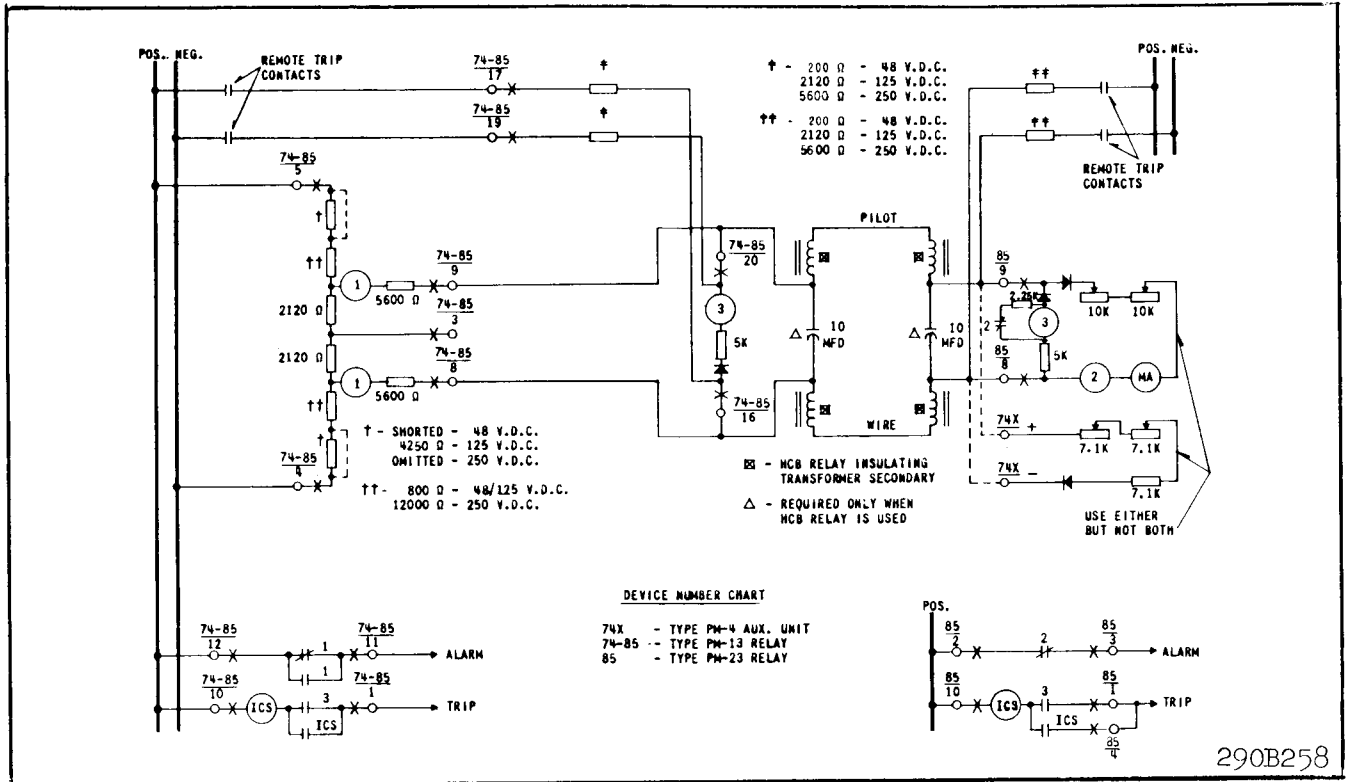

Fig. 31. External schematic of the DC type PM-13 relay with type PM-23 or PM-4 relay - Two terminal lines.

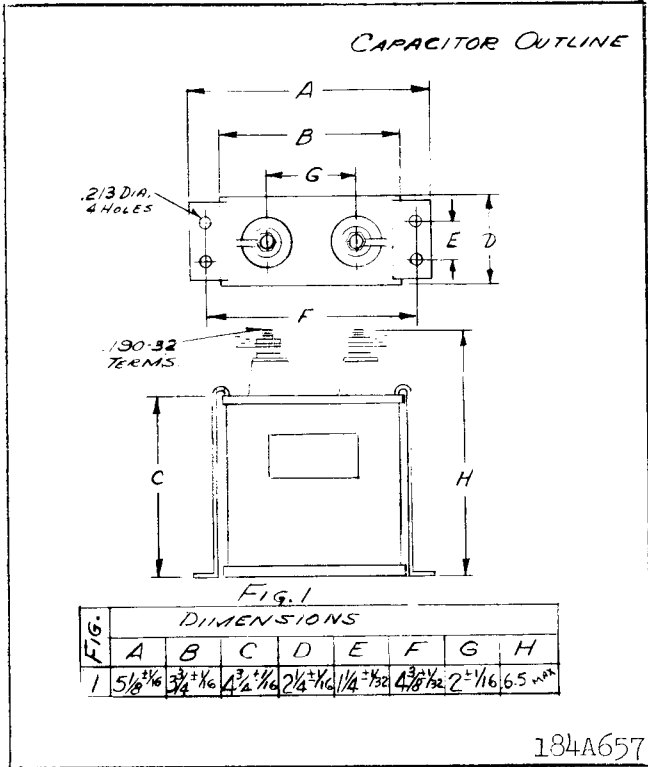

Fig. 32. Outline and Drilling Plan for 10 mfd. capacitor - For reference only.

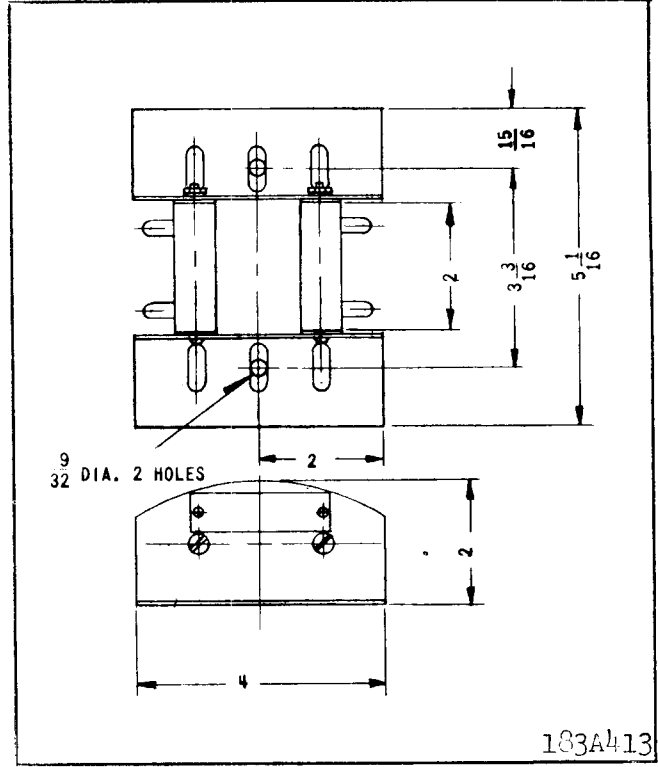

Fig. 33. Outline and Drilling Plan for External Remote Trip Resistor Assembly.

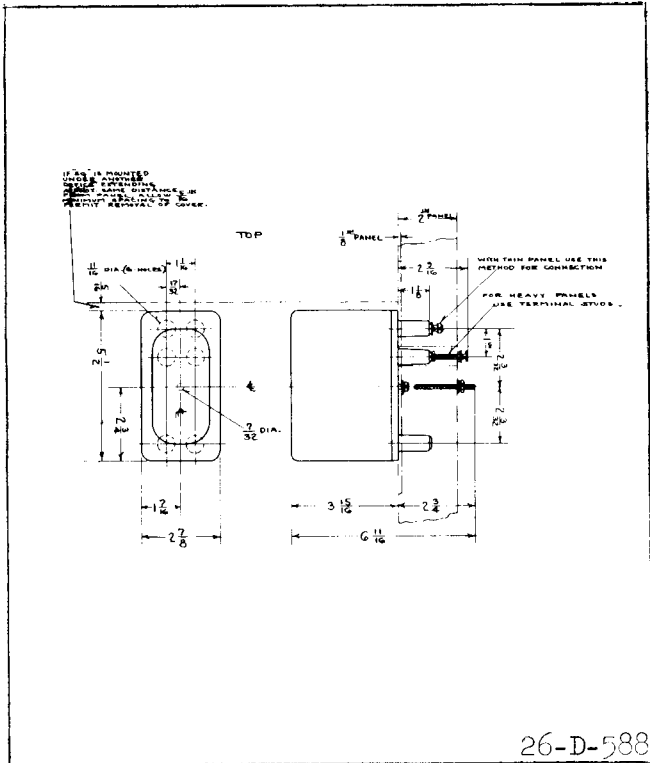

Fig. 34. Outline and Drilling Plan for the type PM-4 Auxiliary unit in the projection molded case.

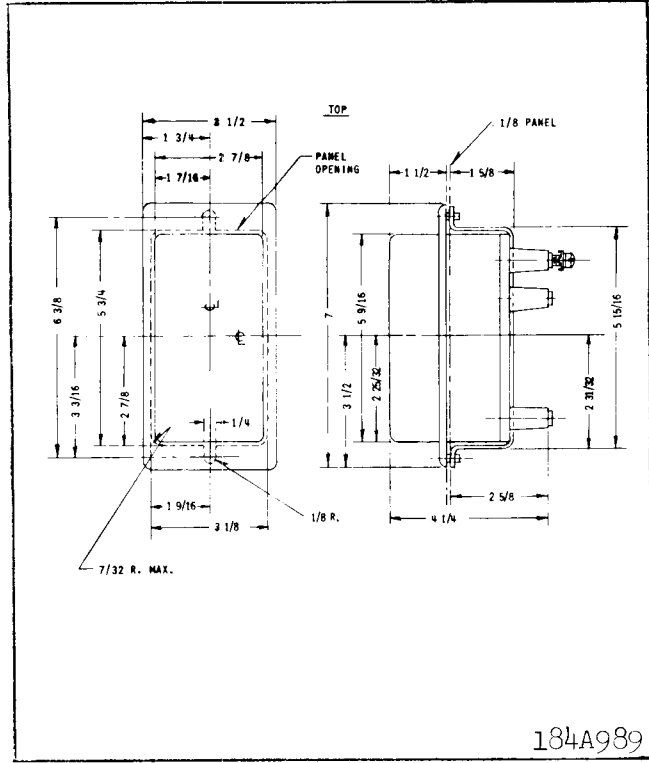

Fig. 35. Outline and Drilling Plan for the type PM-4 Auxiliary unit in the Semi-Flush molded case.

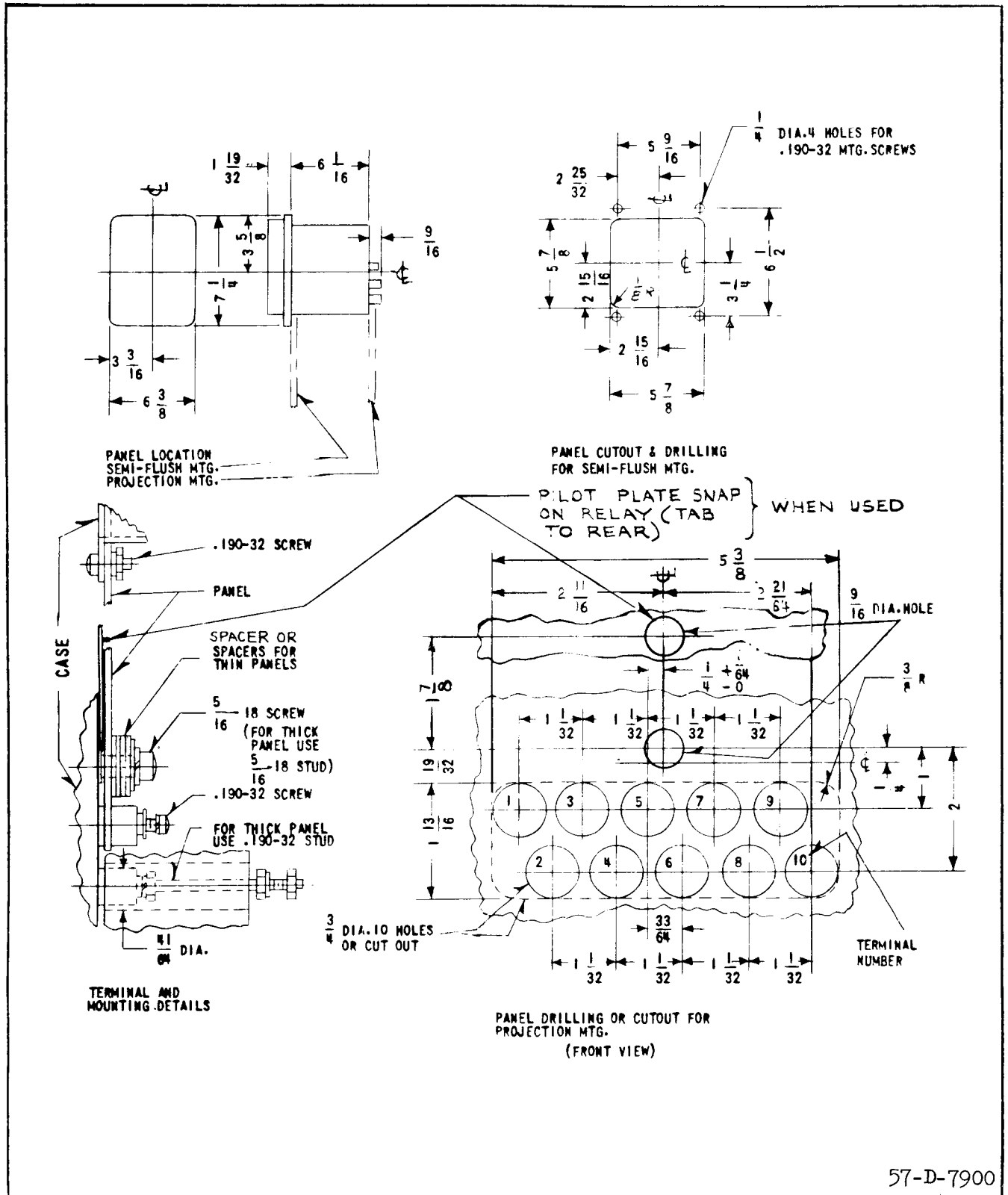
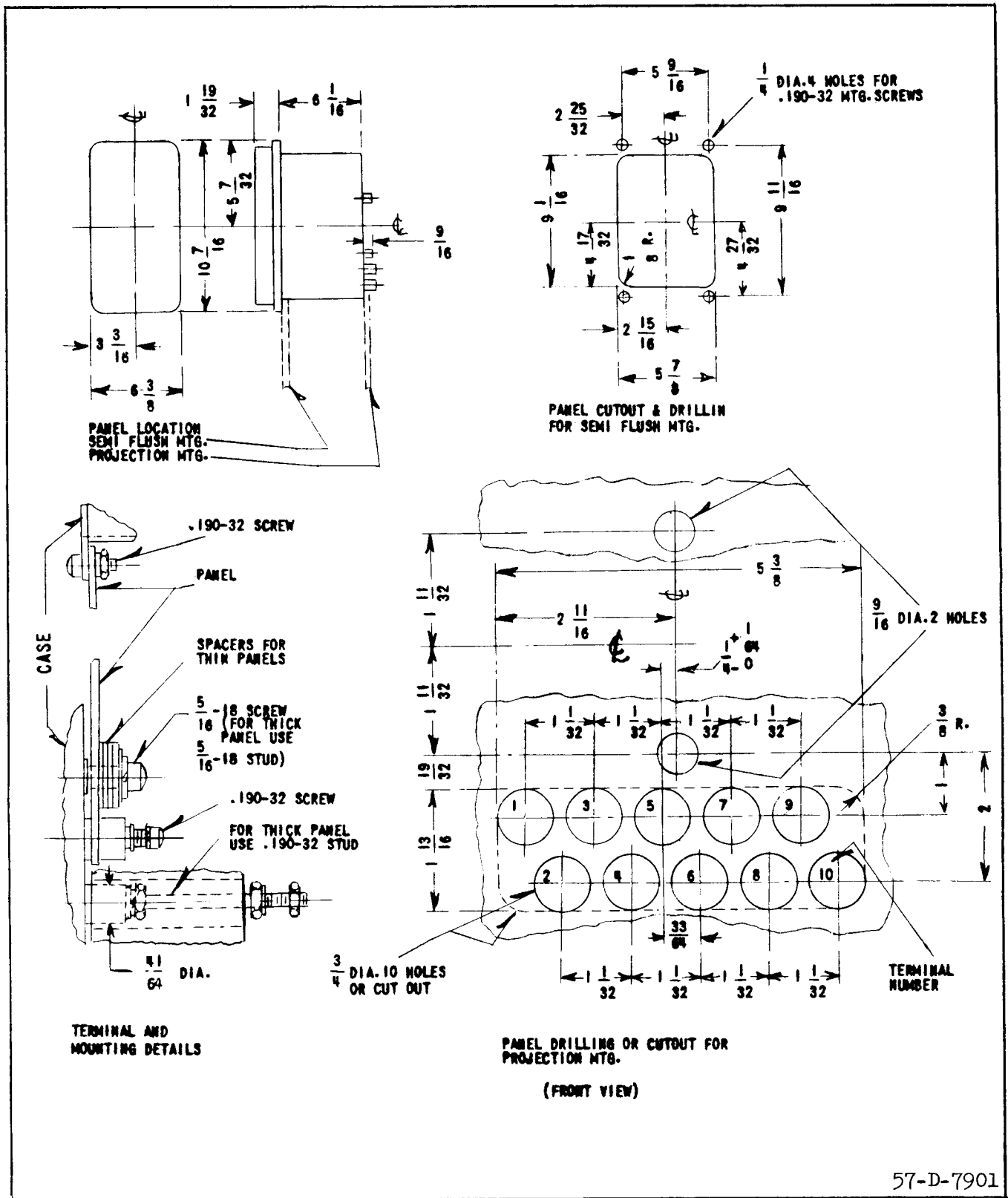

Fig. 36. Outline and Drilling Plan for the type PM-3, PM-5, & PMD-1 Relays in the type FT 11 case.



57-D-7901

Fig. 37. Outline and Drilling Plan for the type PM-2, PM-23, PMA-1 and PMD relays in the type FT 21 case.

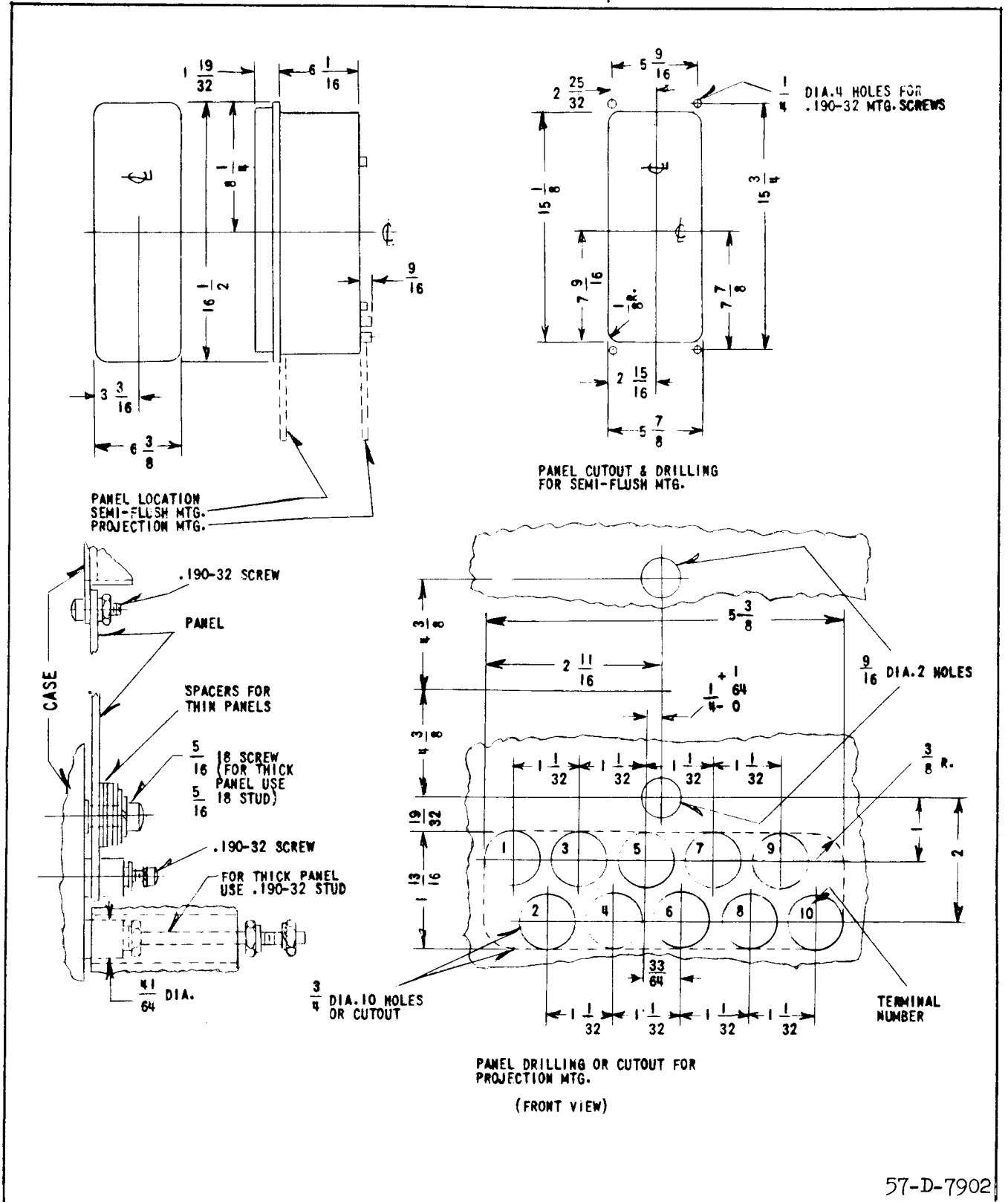
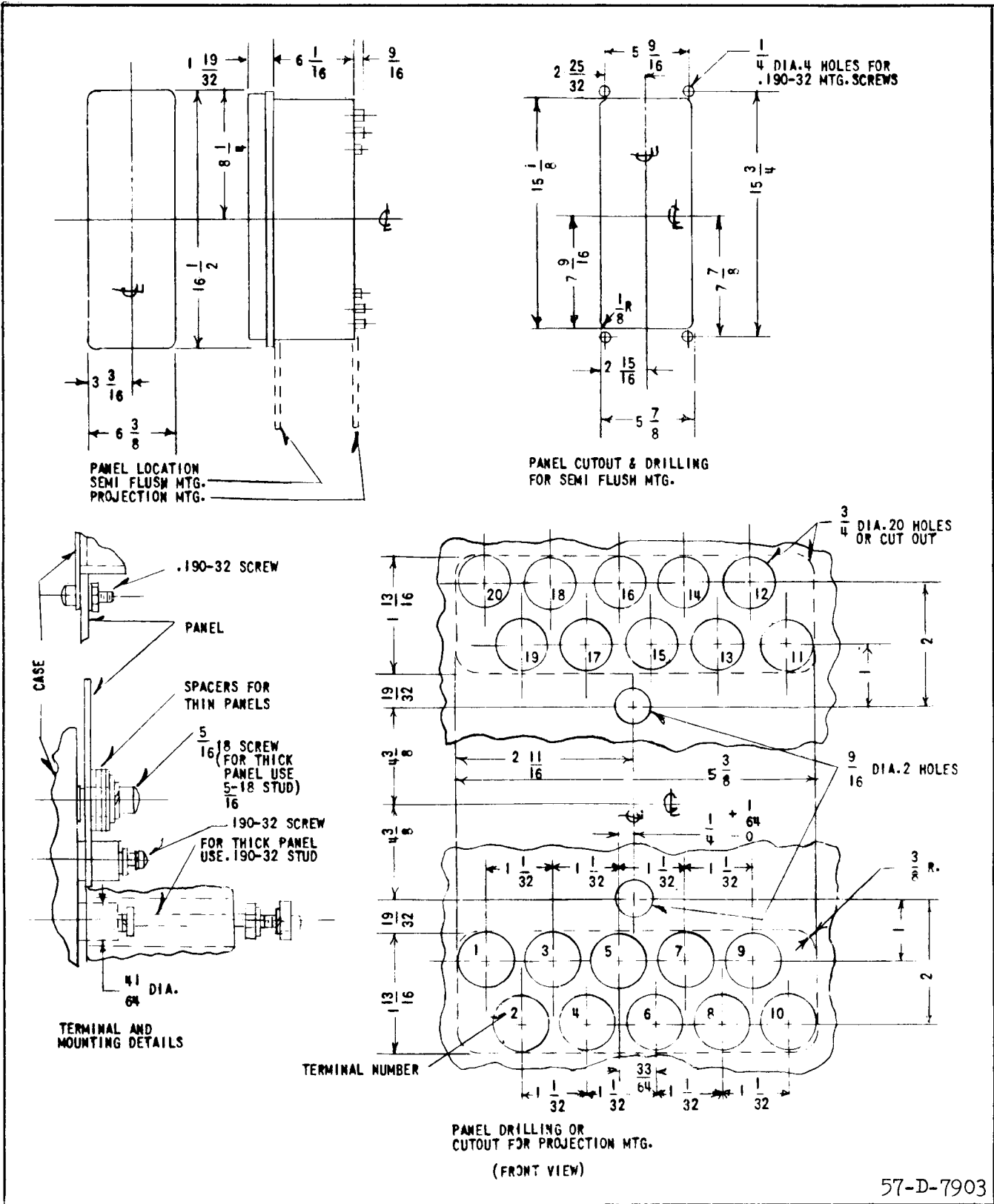

Fig. 38. Outline and Drilling Plan for the type PMA relay in the type FT 31 case.

TYPE PM MONITORING RELAYS



57-D-7903

Fig. 39. Outline and Drilling Plan for the type PM-13 and PMG-13 relays in the type FT 32 case.

WESTINGHOUSE ELECTRIC CORPORATION
RELAY-INSTRUMENT DIVISION **NEWARK, N. J.**

Printed in U.S.A.

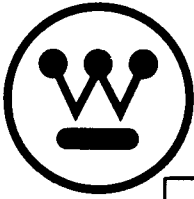

INSTALLATION • OPERATION • MAINTENANCE INSTRUCTIONS

TYPE PM LINE OF RELAYS FOR PILOT-WIRE MONITORING AND TRANSFERRED TRIPPING

CAUTION Before putting protective relays into service, remove all blocking which may have been inserted for the purpose of securing parts during shipment, make sure that all moving parts operate freely, inspect the contacts to see that they are clean and close properly, and operate the relay to check the settings and electrical connections.

APPLICATION

Type PM Monitoring Relays provide continuous monitoring of a pilot-wire circuit to detect open circuits, short circuits, grounds, and wire reversal. In addition, transferred tripping can be effected where the PM-3, PM-13, PMG-13 or PM-23 relays are used. Table I illustrates the functions available with each relay. A 10 mfd. capacitor is supplied with each PM relay. This capacitor provides an a-c path between the two halves of the insulating transformer secondary windings as shown in Figs. 21 through 27.

Each circuit requires the following:

At one end to introduce monitoring current

One of the following:

For a-c Supply

For d-c Supply

PMA	PMD
PMA-1	PMD-1
PM-13 or PMG-13 (a.c.)	PM-13 or PMG-13 (d.c.)

At the other end to receive monitoring current (two-terminal line)

One PM-23 or PM-2 or PM-4

At the other ends to receive monitoring current (three-terminal line)

Two PM-23 or two PM-4 or two PM-2 or any combination of two of these relays.

CONSTRUCTION

PM relays consist of the following:

<u>PMA</u>	<u>PMA-1</u>
1-Polar Alarm Unit (1)	1-Polar Alarm Unit

1-Polar Ground Unit (5)	1-Tapped Transformer
1-Tapped Transformer	1-Full-Wave Rectifier
1-Full-Wave Rectifier	1-4 mfd. Capacitor
3-4 mfd. Capacitors	1-Set of Potential
1-Set of Potential	Dividing Resistors

PMD

1-Polar Alarm Unit (1)
1-Polar Ground Unit (5)
2-4 mfd. Capacitors
1-Set of Potential
Divider Resistors

PMD-1

1-Polar Alarm Unit
1-Set of Potential
Divider Resistors

PMG-13

1-Polar Alarm Unit (1)
1-Polar Ground Unit (5)
1-Polar Trip Unit (3)
1-Indicating Contactor
Switch
1-Set of Potential
Divider Resistors
1-Tapped Transformer
(A.C. Relay only)
1-Full-Wave Rectifier
(A.C. Relay only)
1-Blocking Rectifier
2-Remote Trip Resistors
3-4 mfd. Capacitors
(A-C Relay)
2-4 mfd. Capacitors
(D-C Relay)

PM-13

1-Polar Alarm Unit (1)
1-Polar Trip Unit (3)
1-Indicating Contactors
Switch
1-Set of Potential
Divider Resistors
1-Tapped Transformer
(A.C. Relay only)
1-Full-Wave Rectifier
(A.C. Relay only)
1-Blocking Rectifier
2-Remote Trip Resistor
1-4 mfd. Capacitor

PM-23

1-Polar Alarm Unit (2)
1-Polar Trip Unit (3)
1-Indicating Contactor
Switch (ICS)
1-Milliammeter, 5.0 ma.
1-Set of Adjustable and
Fixed Resistors
2-Blocking Rectifiers

PM-2

1-Polar Alarm Unit (2)
1-Milliammeter, 5.0 ma.
1-Set of Adjustable
Resistors
1-Blocking Rectifier

SUPERSEDES I.L. 41-973.5H

*Denotes change from superseded issue.

EFFECTIVE AUGUST 1973

TYPE PM MONITORING RELAYS

PM-3

- 1-Polar Trip Unit (3)
- 1-Resistor
- 1-Blocking Rectifier
- 1-Indicating Contactor Switch (ICS)

PM-4

- 1-Blocking Rectifier
- 1-Set of Adjustable & Fixed Resistors

PM-5

- 1-Polar Ground Unit (5)
- 2-4 mfd. Capacitors
- 1-Fixed Resistor

TABLE I

FUNCTION	PMA & PMD	PMA-1 & PMD-1	PM-13	PMG-13	PM-23	PM-2	PM-3	PM-4	PM-5
Monitoring Current Source	X	X	X	X					
Receives Monitoring Current					X	X		X	
Trouble Alarm	X	X	X	X	X	X			X
Transmits Trip Signal	X †	X †	X	X	X †	X †	X †	X †	
Receives Trip Signal			X	X	X		X		
Sensitive Ground Detection	X			X					X
Measures Monitoring Current					X	X			

† With External Resistors

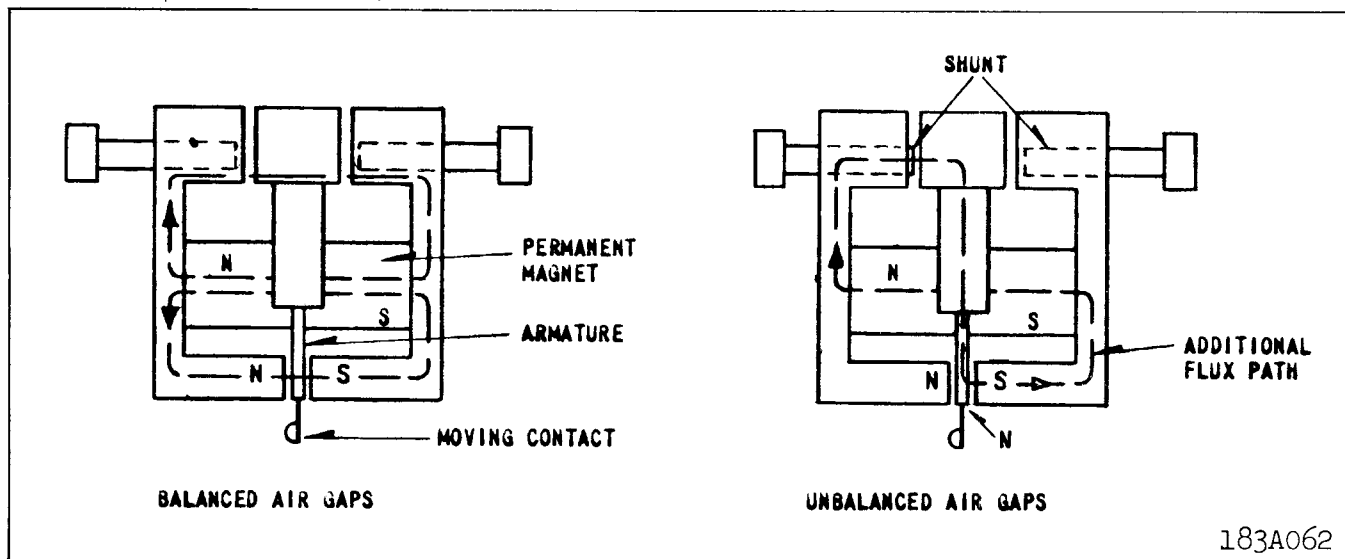

Fig. 1. Polar Unit Permanent Magnet Flux Paths.

183A062

Polar Unit

The polar unit consists of a rectangular shaped magnetic frame, an electromagnet, a permanent magnet, and an armature. The poles of the crescent shaped permanent magnet bridge the magnet frame. The magnetic frame consists of three pieces joined in the rear with two brass rods and silver solder. These non-magnetic joints represent air gaps, which are bridged by two adjustable magnetic shunts. The winding or windings are wound around a magnetic core. The armature is fastened to this core and is free to move in the front air gap. The moving contact is connected to the free end of a leaf spring, which, in turn, is fastened to the armature.

Indicating Contactor Switch

The d-c indicating contactor switch is a small clapper type device. A magnetic armature, to which leaf-spring mounted contacts are attached, is attracted to the magnetic core upon energization of the switch. When the switch closes, the moving contacts bridge two stationary contacts, completing the trip circuit. Also during this operation two fingers on the armature deflect a spring located on the front of the switch, which allows the operation indicator target to drop. The target is reset from the outside of the case by a push rod located at the bottom of the cover.

The front spring, in addition to holding the target, provides restraint for the armature and thus controls the pickup value of the switch.

- * **PMD & PMG13 with Tel. Relay:** In the relays type PMD and PMG13 where they are energized with DC power supply, the ground polar unit (#5) could momentarily close its contact (for about 10 m.s.) if either positive or negative supply is grounded. To eliminate this momentary operation, a telephone relay with a nominal operating time of 25 m.s. was connected in series with contact of the "5" unit, and the contact of the telephone relay is used as an overall contact output of the "5" unit. This type of relay should be used where the DC power supply is subjected to short to the ground.

OPERATION

Pilot Wire Monitoring

Monitoring current is introduced into the pilot wire as shown in the external schematics, figures 21 to 27, by the monitoring current source. External schematics showing other combinations are available on request. A nominal 20 volts is impressed across the 10 mfd. capacitor at the left-hand line terminal in Figures 21 to 27. This voltage produces a current circulating through one winding of the HCB insulating transformer, one pilot wire, the PM-23, PM-2, or PM-4,

and back through the other pilot wire and the other winding of HCB insulating transformer.

Adjustment of the resistors of the PM-23, PM-2 or PM-4 relay at the other end of the pilot wire provides a normal one-milliampere d-c circulating current. In the case of three-terminal lines, the monitoring source relay output current is 2 ma. in order to provide each receiving end relay with 1 ma. The alarm unit of the monitoring current source relay is adjusted to float between the high and low current contacts with normal monitoring current. The PM-23, receiving-end alarm relay, is adjusted to float between the low-current alarm contact and a contact stop with 1 ma. flowing.

Short Circuits

A complete or partial short circuit on the pilot wires increases the current in the current-source relay, causing the high-current alarm contacts to close. The resulting current decrease in the PM-23 relay closes the alarm contact. Short circuits of 5000 ohms or less will be detected.

Open Circuits

Current decreases to zero in all relays. Low-current alarm contact of the current source relay closes. Alarm contact of PM-23 relay closes.

Reversed Wires

On applications using the PM-23 relay, current increases in the sending end relay to close the high-current alarm contacts. Current drops to zero in the PM-23 relay monitoring coil to close the low-current alarm contacts.

If the pilot wire should be opened and reclosed with reversed connections when the PM-23 relay is in service, the alarm contact (2) in the PM-23 drops out. The alarm contact dropping out shunts the trip unit coil (3), and prevents the trip unit contact (3) from operating momentarily. The trip unit contact is prevented from operating because the capacitor at the sending end discharges through the pilot wire and the trip unit (3) circuit. This will have no effect on remote trip operation.

The current decreases in both sending and receiving end relays when the PM-2, or PM-4 relays are used. Low current alarm contacts close.

Grounds

The voltage-divider circuit of the PMA, PMD, and PMG-13 source relays has its midpoint grounded through a current-limiting resistor. Thus, a pilot-wire ground will cause an increase in current in one coil circuit, and a decrease in the other one. This unbalance in the current flowing through the two windings (5) of the ground alarm relay unit will cause it to close one of its contacts (depending on which pilot

TYPE PM MONITORING RELAYS

wire is grounded) to give an alarm. Grounds of 10,000 ohms or less will be detected.

For adding the sensitive ground detection where PMA-1, PMD-1, or PM-13 relays have been installed, the PM-5 relay can be added to the circuitry, as shown in figure 24. This relay also has a 10,000-ohm ground sensitivity.

Transferred Tripping

Breakers located at the PMG-13 or PM-13 and PM-3 or PM-23 stations can be tripped by the application of a d-c voltage to the pilot wires at remote locations, as shown in figures 21 to 27. Transferred tripping can be effected from any location by applying 48 volts d-c (through dropping resistors when required) to the pilot wire with polarity opposite to that of the monitoring voltage. When tripping the PM-23, the current is increased above 2.0 ma, in reverse direction, to close the trip contact. When tripping the PMG-13 or PM-13, the reversed d.c. voltage operates the trip unit (3).

See Tables II and III for tripping resistor values. Nominal tripping currents is 5ma. at all rated voltages.

Polar Unit

Polar unit flux paths are shown in figure 1. With balanced air gaps, permanent magnet flux flows in two paths, one through the front, and one through the rear gaps. This flux produces north and south poles, as shown. By turning the left shunt in, some of the flux is forced through the armature, making it a north pole. Thus, reducing the left hand rear gap will produce a force tending to pull the armature to the right. Similarly, reducing the right hand gap will make the armature a south pole and produce a force tending to pull the armature to the left.

The alarm unit contacts of the sending and receiving end relays are biased to move to the left when the relay is deenergized. The PMG-13 or PM-13 and PM-23 trip unit contact is biased to move to the left when the relay is deenergized. The PM-5 is adjusted so that the moving contact floats when the relay is deenergized.

CHARACTERISTICS

Nominal Calibration Values

Nominal current values to close contacts are listed in Tables IV and V.

Voltage Ratings

Supply voltage ratings of the monitoring source relays to obtain continuous monitoring current are as follows:

DC - 48, 125, and 250 volts

AC - 120 volts, 60 cycles (Primary taps 100, 110, 120 & 130)

Voltage impressed on the pilot wire is a nominal 20 volts for monitoring, and 48 volts for tripping.

Supply voltage ratings to obtain remote tripping are: 48, 125, and 250 volts d-c.

Coil Resistance (each winding)

Alarm coil (1)	
two terminal line	1050-1250 ohms
three terminal line	700-900 ohms
Alarm coil (2)	2200-2600 ohms
Trip coil (3)	1800-2200 ohms
Ground Alarm coil (5)	5200-5800 ohms

PM-4 and PM-23 Resistance

Nominal PM-4 and PM-23 total resistance when adjusted for service is 20,000 ohms less pilot wire loop resistance at 1 ma.

PMA, PMA-1 and AC PMG-13, PM-13 Burden

0.5 VA at tap voltage	-	2-terminal line relay
1.0 VA at tap voltage	-	3-terminal line relay

Rectifiers

Approximate forward resistance - 560 ohms at 1 ma
300 ohms at 2 ma

Rating

Continuous forward	
current - amperes	- 1
Continuous back	
voltage - rms volts	- 200

Remote Tripping

Remote trip resistors are listed in Table II and III for 48, 125, and 250 volts d-c.

The relays have sufficient thermal capacity to withstand 20 MA d-c continuously when remote tripping. Nominal trip currents in the tripping relays are 5.0 MA d-c with 48, 125, and 250 volts d-c supply and a 2000-ohm pilot wire.

TABLE II

**PMA, PMA-1, PMD, AND PMD-1 APPLICATIONS
EXTERNAL RESISTORS FOR D.C. REMOTE TRIPPING
(2 REQUIRED PER STATION)**

# LINE TERMINALS	D.C. VOLTAGE	STATION A PMA or PMA-1	STATION A PMD or PMD-1	STATION B PM-2 & PM-3 or PM-23 or PM-4	STATION C PM-2 & PM-3 or PM-23 or PM-4	TO OPERATE
2	48	200	200	—	—	PM-23 or PM-3
	125	3550	3550	—	—	"
	250	9300	9300	—	—	"
3	48	200	200	—	—	"
	125	2000	2000	—	—	"
	250	5600	5600	—	—	"

TABLE IIIA

**PMG-13 AND PM-13 (D.C. SUPPLY) APPLICATIONS
RESISTORS FOR D.C. REMOTE TRIPPING
(2 REQUIRED PER STATION)**

# LINE TERMINALS	D.C. VOLTAGE	STATION A PMG-13 or PM-13	STATION B PM-2 & PM-3 or PM-23 or PM-4	STATION C PM-2 & PM-3 or PM-23 or PM-4	TO OPERATE
2	48	200 †	200	—	PMG-13 or PM-13 and PM-23 or PM-3
	125	2120 †	2120	—	"
	250	5600 †	5600	—	"
3	48	200 †	200	200	"
	125	1500 †	1500	1500	"
	250	4000 †	4000	4000	"

† Mounted in Relay

TABLE IIIB

**PMG-13 AND PM-13 (A.C. SUPPLY) APPLICATIONS
(2 REQUIRED PER STATION)
RESISTORS FOR D.C. REMOTE TRIPPING**

# LINE TERMINALS	D.C. VOLTAGE	STATION A PMG-13 or PM-13	STATION B PM-2 & PM-3 or PM-23 or PM-4	STATION C PM-2 & PM-3 or PM-23 or PM-4	TO OPERATE
2	48	200 †	200	—	PMG-13 or PM-13 and PM-23 or PM-3
	125	2120 †	2120	—	"
	250	5600 †	5600	—	"
3	48	200 †	200	200	"
	125	1500 †	1500	1500	"
	250	4000 †	4000	4000	"

† Mounted in Relay

TYPE PM MONITORING RELAYS

TABLE IV

NOMINAL CALIBRATION VALUES - TWO TERMINAL LINES

<u>RELAY</u>	<u>LOW CURRENT ALARM</u> ¹	<u>HIGH CURRENT ALARM</u> ²	<u>TRIP</u>
PMA or PMA-1	0.7 ma	1.3 ma	—
PMD or PMD-1	0.7	1.3	—
PM-5 †	—	±0.3	—
PMG-13 or PM-13	0.7 ††	1.3 ††	14 V.
PM-23 or PM-2 & PM-3 †	0.7	—	14 V.

† Same relay as for three-terminal lines

†† These are pilot-wire current values

1—Left-hand contacts, front view.

2—Right-hand contacts, front view.

TABLE V

NOMINAL CALIBRATION VALUES - THREE TERMINAL LINES

<u>RELAY</u>	<u>LOW CURRENT ALARM</u>	<u>HIGH CURRENT ALARM</u>	<u>TRIP</u>
PMA or PMA-1	1.7 ma	2.3 ma	—
PMD or PMD-1	1.7	2.3	—
PM-5 †	—	±0.3	—
PMG-13 or PM-13	1.7 ††	2.3 ††	14 V.
PM-23 or PM-2 & PM-3 †	0.7	—	14 V.

† Same relay as for two-terminal lines

†† These are pilot-wire current values

Trip Circuit

The main contacts will safely close 30 amperes at 250 volts d-c and the seal-in contacts of the indicating contactor switch will safely carry this current long enough to trip a circuit breaker.

The indicating contactor switch has two taps that provide a pickup setting of 0.2 or 2 amperes. To change taps requires connecting the lead located in front of the tap block to the desired setting by means of a screw connection.

Trip Circuit Constant

Indicating Contactor Switch (ICS)

0.2 ampere tap 6.5 ohms d-c resistance

2.0 ampere tap 0.15 ohms d-c resistance

SETTING THE RELAY

Operating units of all relays are adjusted in the factory to the values listed in Tables IV and V to a tolerance of ±5%. No settings are required on these units.

For all 48/125-volt d.c. relays, connect jumpers across resistors as shown on the internal schematics.

PM-4, PM-2, and PM-23 Relays

Adjust the resistors in the PM-4, PM-2, or PM-23 relay or relays to a value of 1 MA d-c with the monitoring circuits connected for service. Use the milliammeter in the PM-23 for this purpose or use a portable milliammeter with a resistance of less than 200 ohms. Where it is not practical on three-terminal lines to adjust both receiving relays simultaneously, set one receiving relay for 18,000 ohms total resistance (including relay coil and resistors) by measurement prior to final adjustment of the other receiving relay. This procedure will minimize the change in monitoring current in the first relay to be adjusted when making the final adjustment of the second relay.

PMA, PMA-1, PMG-13 and PM-13 Relays

Select the transformer tap nearest to expected normal a-c supply voltage. The full wave rectifier is

connected to a secondary transformer tap. Where desired, the output voltage can be raised about 5% by reconnecting across the full secondary winding.

Indicating Contactor Switch

No setting is required on the ICS unit except the selection of the 0.2 or 2.0 ampere tap setting. This selection is made by connecting the lead located in front of the tap block to the desired setting by means of the connecting screw. When the relay energizes a type WL relay switch, or equivalent, use the 0.2 ampere tap.

INSTALLATION

The relays should be mounted on switchboard panels or their equivalent in a location free from dirt, moisture, excessive vibration, and heat. Mount the relay vertically by means of the four mounting holes on the flange for semi-flush mounting or by means of the rear mounting stud or studs for projection mounting. Either a mounting stud or the mounting screws may be utilized for grounding the relay. The electrical connections may be made directly to the terminals by means of screws for steel panel mounting or to the terminal studs furnished with the relay for thick panel mounting. The terminal studs may be easily removed or inserted by locking two nuts on the stud and then turning the proper nut with a wrench.

For detailed FT case information, refer to I.L. 41-076.

Where the potential to ground impressed on the relays can exceed 700 volts, a drainage reactor in conjunction with a KX-642 tube, or the reactor in conjunction with 700 volt carbon-block arresters, is recommended. For details, see Protection of Pilot-Wire Circuits, AIEE Committee Report, paper 58-1190, AIEE Transactions, 1959, Volume 78, Part III B pp. 205-212. Also, see AIEE Special Publication S-117, Applications and Protection of Pilot-Wire Circuits for Protective Relaying, July 1960.

ADJUSTMENTS AND MAINTENANCE

The proper adjustments to insure correct operation of this relay have been made at the factory and should not be disturbed after receipt by the customer. If the adjustments have been changed, the relay taken apart for repairs, or if it is desired to check the adjustments at regular maintenance periods, the instructions in the succeeding sections should be followed.

Acceptance Tests

The following tests are recommended when the relay is received from the factory. If the relay does not perform as specified below, the relay either is not properly calibrated or it contains a defect.

Indicating Contactor Switch (ICS)

Close the contact of the tripping unit and pass sufficient direct current through the trip circuit to close the contacts of the ICS unit. This value of current should not be greater than the particular ICS tap setting being used (0.2 or 2.0). The indicator target should drop freely.

PMA and PMA-1 Relays

Alarm Unit (1)

Set the primary tap on 120 volts. Connect a variable resistor of approximately 20,000 ohms in series with a low-range d-c milliammeter across terminals 6 and 7 with the instrument positive connected to terminal 7. Apply 120 volts at rated frequency to terminals 4 and 5. Adjust the 20,000-ohm resistor to obtain a current of one ma. d.c. For a three-terminal line relay, use a 10,000-ohm resistor and set the current to 2 ma. d.c. At this value, the moving contact of the alarm or monitoring relay unit (1) should float between the two sets of stationary contacts. In the PMA relay, the ground alarm unit (5) contact should also float. (This contact will also float when the relay is de-energized.) Increase and decrease the one or two-milliamper monitoring current to check the calibration values listed in Tables IV and V.

Ground Unit (5)

Reconnect the 20,000-ohm resistor. For the PMA relay only, short terminals 7 and 3. The contact of the ground alarm unit (5) should close to the right when the relay is energized. Remove the short, and connect it between terminals 6 and 3. The ground alarm unit (5) should close to the left. The action of the monitoring unit (1) contact is of no significance in this simulated pilot-wire ground test. To check the pickup current of the ground detector, first remove the 20,000-ohm resistor from terminals 6 and 7. Connect a 0-1 d.c. milliammeter in series with a variable resistor of about 50,000 ohms between terminals 3 and 6. The ground unit should close its left-hand contact at approximately 0.3 ma. d.c. With the milliammeter and resistor connected between terminals 3 and 7, the right-hand contact should close at 0.3 ma. d.c.

TYPE PM MONITORING RELAYS

PMD and PMD-1 Relays

Alarm and Ground Units

Connect an adjustable 20,000-ohm resistor (or 10,000-ohms for a 3-terminal relay) in series with a d-c milliammeter across terminals 6 and 7 with the instrument positive connected to terminal 7. Apply rated d-c voltage to terminals 8 and 9 with positive on terminal 9. Now check the PMD and PMD-1 relays, following the procedure given in the previous section for the PMA and PMA-1 relays, respectively. Note, however, that terminal 5 of the PMD relay corresponds to terminal 3 of the PMA relay.

PM-2, PM-3, and PM-23 Relays

Alarm Unit (2)

Apply a variable d-c voltage of approximately 20 volts to relay terminals 8 and 9 (terminal 9 positive) of the PM-2 or PM-23 relay. Adjust the voltage to obtain a reading of one ma. on the relay milliammeter. The monitoring polar unit (2) contacts should float. Reduce the current gradually. The monitoring alarm contacts should close at 0.7 ma. d.c. The tripping unit (3) of the PM-23 relay should not move during this test. The milliammeter has been adjusted to read 1 ma. $\pm 5\%$. As a result the pointer may not read zero for a zero current condition.

Tripping Unit (3)

To check the PM-3 relay or the tripping unit of the PM-23 relay, apply the variable d-c voltage in series with an external milliammeter to relay terminals 8 and 9 with terminal 8 positive for the PM-23 relay, or terminal 9 positive for the PM-3 relay. When checking the pickup of the PM-23 trip unit block open the alarm unit contacts (2) so as to remove the shunt resistor from around the trip coil (3).

The tripping relay unit (3) should pick up with positive action at 14 volts d.c. and should drop out at approximately 10 volts. The alarm unit of the PM-23 relay will not operate during this test.

PM-4 Relay

This device is simply a set of resistors and a diode to connect into the pilot-wire circuit to provide a path for the monitoring current. The resistors can be checked with an ohmmeter, and the diode can be checked either with an ohmmeter, or as explained in the section entitled "Rectifier Check" under "Routine Maintenance". If an ohmmeter is used, the difference in forward and reverse resistance readings obtained will be dependent on the current flowing through the diode.

PM-5 Relay

Apply 5 volts d.c. in series with a 0-1 d.c. milliammeter and a 20,000-ohm variable resistor to terminals 6 and 7 with positive on terminal 6. The left-hand contact should close at approximately 0.3 ma. Now apply the same circuit to terminals 8 and 9 with positive on terminal 9. The right-hand contact should close at approximately 0.3 ma.

PM 13 Relays - A.C. and D.C.

Alarm Unit (1)

Connect a variable 20,000-ohm resistor (10,000 ohms for a 3-terminal-line relay) in series with a d-c milliammeter across terminals 8 and 9 with the instrument positive on terminal 9. For the a-c relay, set the primary tap on 120 volts. Now apply the rated supply voltage to terminals 4 and 5. This will be 48, 125, or 250 volts d.c., or 120 volts a.c. as indicated on the relay nameplate. Adjust the variable resistor to obtain a current of one ma. for a 2-terminal line relay, or 2 ma. for a 3-terminal relay. At this value, the moving contacts of the alarm or monitoring (1) relay unit (the upper polar unit) should float between the two sets of stationary contacts. Increase and decrease the one or 2 ma. monitoring current to check the calibration values listed in Tables IV and V.

Tripping Unit (3)

To check the operation of the tripping unit 3 (the lower polar unit), apply a d.c. potential across terminals 16 (positive) and 20 (negative). The tripping polar unit should pick up at 14 volts, and should drop out at approximately 10 volts. The resistance of the series dropping resistors for transferred tripping (listed in Tables III A and III B) can be checked with an ohmmeter. The circuit location of these resistors can readily be seen from the external schematic, Figure 27.

PMG-13 Relays - A.C. and D.C.

Alarm and Tripping Units

Follow the procedure given in the previous section for the a-c. and d-c. PM-13 relays.

Ground Unit (5)

Connect the 20,000-ohm (or 10,000-ohm) resistor and milliammeter across terminals 8 and 9. With rated voltage applied and one ma. (or 2 ma.) flowing, successively short circuit terminals 3 and 8, then 3 and 9. The ground alarm unit 5 (lower polar unit) should move first to the left, then to the right. To check the pickup current of the ground detector, first remove the 20,000-ohm resistor from terminals 8 and 9. Connect a 0-1 d.c. milliammeter in series

with a variable resistor of about 50,000 ohms between terminals 3 and 8. The left-hand contact should close at approximately 0.3 ma. d.c. With the milliammeter resistor connected, between terminals 3 and 9, the right-hand contact should close at 0.3 ma. d.c. The external schematic diagrams for these relays are shown in Figure 23 and 25.

Routine Maintenance

CAUTION - Do not make any performance check, calibration tests, or adjustments while the PM relays are energized or connected to the pilot wires, to prevent the possibility of inadvertently causing a break operation. The PM relays may be removed from service for testing, without jeopardizing HCB relay protection, providing that the connections between the 10-mfd capacitor and the HCB insulating transformer are not disturbed.

Contacts

All contacts should be periodically cleaned. A contact burnisher S#182A836H01 is recommended for this purpose. The use of abrasive material for cleaning contacts is not recommended because of the danger of embedding small particles in the face of the soft silver and thus impairing the contact.

Operational Check

In addition to cleaning contacts, it is recommended that an operational check be performed periodically by opening and short-circuiting the pilot wires, as well as grounding them at the relay terminals. **Note:** These pilot-wire faults should not be applied directly to the pilot wires when the HCB relays are in service. It is also recommended that the trip circuits of the PM relays be opened (where tripping is used), to prevent the possibility of inadvertently tripping the associated circuit breaker during testing. If the relays do not perform as expected, and diode failure is suspected, the diode tests described in the following section may be performed.

Rectifier (Diode) Check

If there is suspicion of a rectifier (diode) failure, apply 30 volts d.c. reverse voltage (positive on arrowhead) through a 300-ohm resistance to the diode. Measure the voltage across the diode. If this voltage is not essentially 30 volts, the diode is short-circuited. Now apply 30 volts d.c. in the forward direction through the 300-ohm resistor, and measure the voltage across the resistor. If the voltage is not essentially 30 volts, the diode may have a high forward resistance. If the voltage is zero, the diode is open-circuited.

Calibration

If the relay has been dismantled or the calibration has been disturbed, use the following procedure for calibration.

With the permanent magnet removed, see that the moving armature floats in the central area of the air-gap between the poles of the polar unit frame. If necessary, loosen the core screw in the center rear of the unit and shift the core and contact assembly until the armature floats. (This can best be done with the polar unit removed from the relay.) Then retighten the core screw and replace the permanent magnet with the dimple (north pole) on the magnet to the left when viewed from the front.

Polar Units-General

The following mechanical adjustments are given as a guide, and some deviation from them may be necessary to obtain proper electrical calibration.

Magnetic Shunt Adjustment

The sensitivity of the polar unit is adjusted by means of two magnetic, screw-type shunts at the rear of the unit, as shown in Fig. 1. These shunt screws are held in proper adjustment by a flat strip spring across the back of the polar unit frame, so no locking screws are required. Looking at the relay, front view turning out the right-hand shunt to open the right-hand air gap decreases the amount of current required to close the right-hand contact. Conversely, drawing out the left-hand shunt increases the amount of current required to close the right-hand contact, or decreases the amount of current required to close the left-hand contact (with the proper direction of current flow). Also, if a relay trips to the right at the proper current, the dropout current can be raised by turning in the right-hand shunt. The two shunt-screw adjustments are not independent, however, and a certain amount of trimming adjustment of both shunt screws is generally necessary to obtain the desired pickup and dropout calibration.

In general, the farther out the two shunt screws are turned, the greater the toggle action will be, and as a result, the lower the dropout current. For the tripping units (3) of the PM-3, PM-13, and PM-23 relays, toggle action is desirable, with a dropout current around 75 percent of the pickup current. For the monitoring alarm relay units, toggle action is not desired. Instead, the armature is adjusted to float between the pole faces at a given current (1 or 2

TYPE PM MONITORING RELAYS

The following chart indicates the units present in each relay.

FUNCTION AND UNIT	PMA PMD	PMA-1 PMD-1	PM2	PM3	PM4	PM5	PM13	PMG13	PM23
Alarm for p.w. open, short or reversal (1) (2)	X	X	X				X	X	X
Transfer- Trip Unit (3)				X			X	X	X
Alarm for p.w. ground (5)	X					X		X	
D.C. Path for Monitoring Current					X				

ma.), and to move gradually toward the high or low-current alarm as the coil current is increased or decreased. Similarly, the floating adjustment of the armature of the ground alarm unit (5) requires that both shunt screws be turned in relatively far. Then the armature will move gradually to the left or right as the current through the two #5 coils is unbalanced.

The electrical calibration of the polar unit is also affected by the contact adjustment as this changes the position of the polar unit armature. Do not change the contact adjustment without rechecking the electrical calibration.

Contact Adjustment - All Relays

For all monitoring alarm units, designated (1) or (2), turn in all the stationary contact and contact stop screws until they just touch the moving contact. Advance the screws to hold the armature in the central portion of the magnetic air gap between the two pole faces. (The stationary contact screws have a round silver contact face; the stop screws do not have this silver facing.) Now back off all the contact and contact stop screws one full turn. This will give a total contact travel of 0.050 inch. When the relay is properly calibrated, some touch-up adjustment may be necessary so that double contacts will both close at the same current value. The contact gap between the floating moving contact and the right-hand or left-hand stationary contacts or contact stops will be approximately 0.025 inch when the relay is in operation.

For the tripping (3) units of the PM-3, PM-13, PMG-13, and PM-23 relays, adjust the contacts as described in the previous paragraph, except back off the contact and stop screws one-half turn each to

give a total moving contact travel of approximately 0.025 inch. In operation of the tripping unit, the moving contact will normally rest against the contact stop screws, and will pick up only for a transferred-tripping operation.

For the pilot-wire ground alarm unit (5) of the PMA, PMD, PM5, and PMG-13 relays, follow the same general procedure except back off both stationary contact screws two turns each. This will give a contact gap of 0.050 on each side of the moving contact when it is its normal central position.

Electrical Calibration - All Relays

In the following sections, the calibration instructions are given for the polar unit which performs a certain function, such as alarm (1) or (2), ground (5), or trip (3), rather than giving calibration instructions for each complete relay. In this way, considerable duplication of instructions has been eliminated.

Alarm Unit (1)

Connect the relay as described under Acceptance Tests for the particular relay involved. Screw the two magnetic shunts all the way in, then back them out five turns each. With the relay energized at rated voltage, set the monitoring current at 1.3 or 2.3 ma. d.c. for 2 or 3-terminal relay respectively, by adjusting the external resistor. If the relay does not close its right-hand contact, turn in the left shunt screw until the right-hand contact just closes. If the right-hand contact is closed at 1.3 ma., turn in the right shunt until a point is reached when the right-hand contact is just closed at 1.3 ma.

Now drop the current to 0.7 ma. and adjust the opposite shunt until the left-hand contact just closes

at 0.7 ma. d.c. At 1.0 ma. d.c., the moving contact should float half way between the two sets of stationary contacts with a 0.025-inch gap on each side. Recheck the high and low current calibration several times, touching up the shunt adjustments as required to obtain the desired calibration.

Polarization Check

For all the source relays, which are listed below, make the following additional calibration check:

- PMA
- PMA-1
- PMD
- PMD-1
- PM-13 (a.c. and d.c.)
- PMG-13 (a.c. and d.c.)

After calibration as described in the previous sections, connect a 20,000 ohm resistor (or 10,000 ohms for 3-terminal applications) across the output terminals, and energize the relay at its rated supply voltage. With these connections, approximately one (or two) milliamperes d.c. will flow through the monitor relay coils and external resistor, thus representing normal operating conditions.

Now momentarily (one second or so) apply 48 volts d.c. directly to the pilot-wire terminals of the relay, as indicated in the following table.

Relay	Terminals for Momentary Application of 48 V. d.c.	
	POS.	NEG.
PMA, PMA-1 } PMD, PMD-1 }	6	7
PM-13 (a.c. or d.c.) } PMG-13 (a.c. or d.c.) }	8	9

After momentary application of the transfer-trip voltage as just explained, recheck the calibration of the monitoring alarm unit (1). If it has changed, make necessary trimming adjustments of the shunt screws until there is no change in calibrating of the alarm unit (1) after the transfer-trip voltage has been applied. The purpose of this test is to compensate for the small residual magnetism in the relay unit. The ground alarm unit (5) will not be affected by this test as the ampere-turns of the two windings cancel each other.

Alarm Unit (2)

For the alarm unit of the PM-2 or PM-23 relays, adjust the shunts so that the relay moving contact

floats at one ma. d.c., and closes the left-hand contact at 0.7 ma. d.c. The moving contact should float midway between the contact and contact stop at 1.0 ma. d.c. There is no high-current calibration for this relay unit.

Now apply 48 volts d.c. momentarily (one second or so) across the alarm unit coil-circuit terminals in a direction to operate the alarm relay. Then recheck the alarm unit calibration. If there is any change, touch up the shunt adjustments until there is no change in calibration after 48 v. d.c. has been applied.

Tripping Unit (3)

To calibrate the tripping unit of the PM-3, PM-13, PMG-13, or PM-23 relays apply a d.c. voltage as explained below, to the following relay terminals:

Relays	D.C.	Voltage
	Pos.	Neg.
PM-3	9	8
PM-13 (a.c. or d.c.)	16	20
PMG-13 (a.c. or d.c.)	8	9
PM-23	8	9

Momentarily (one second or so) apply 48 volts d.c. to the terminals shown in the chart. Then starting with both shunts all the way in, turn out the right-hand shunt screw until the relay closes its right-hand trip contact at 14 volts d.c. (This will give approximately 2 ma. through the relay coil.) Now draw out the left-hand shunt until the relay resets with toggle action (not gradually) at not less than 10 volts d.c. When the calibration is approximately correct, again apply 48 volts d.c. to the indicated terminals, then recheck the pickup and dropout voltage, making any necessary trimming adjustments of the shunts. When the relay is properly adjusted, the application of 48 volts.d.c. will not change the pickup or dropout voltage points. The relay should trip and reset with toggle action in this application. This will require both shunt screws to be withdrawn farther than for float- ing action.

Ground Alarm Unit (5)

For the PM-5 relay, turn both shunt screws all the way in, then back them out five turns each. Pass a current of 0.3 ma. d.c. in terminal 6 and out terminal 7. Following the same general procedure as described previously in the section entitled "Alarm Unit (1)," adjust the shunt screws so that the left-hand contact closes at 0.3 ma. Now pass 0.3 ma. d.c.

TYPE PM MONITORING RELAYS

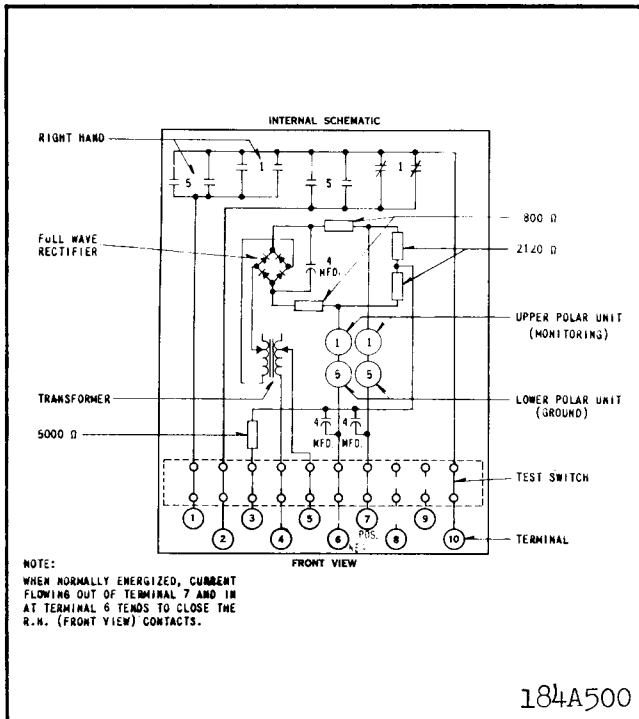

Fig. 2. Internal schematic of the type PMA relay in FT 31 case - 120 volt, 60 cycle supply - For two terminal lines.

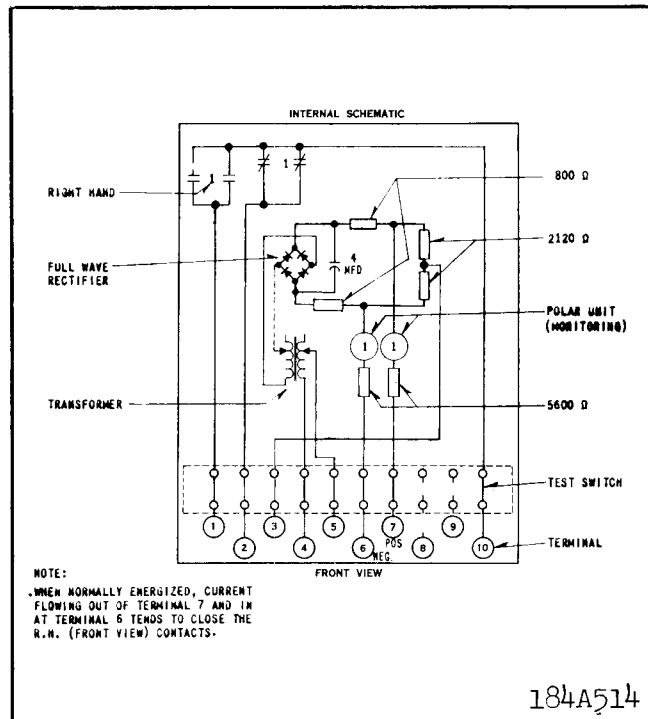

Fig. 3. Internal schematic of type PMA-1 relay in the FT 21 case - 120 volts, 60 cycle supply - For two terminal lines.

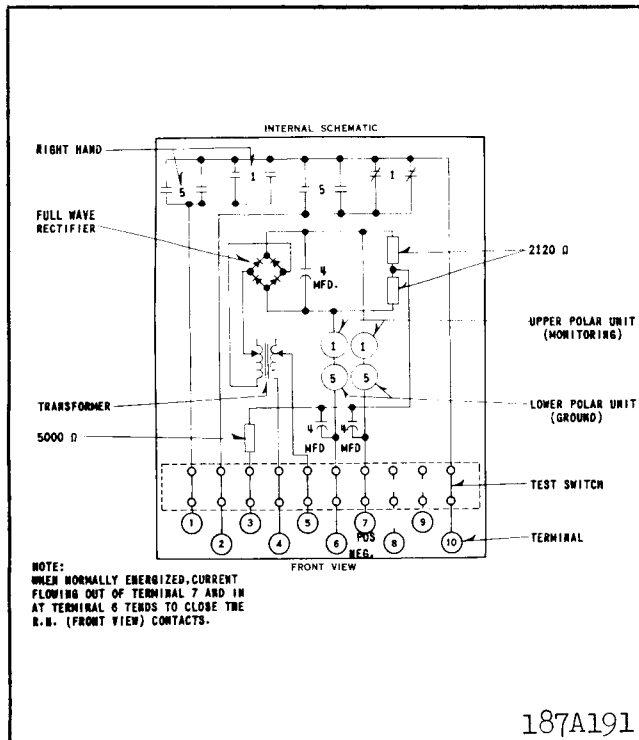

Fig. 4. Internal schematic of type PMA relay in FT 31 case - 120 volt, 60 cycle supply - For three terminal lines.

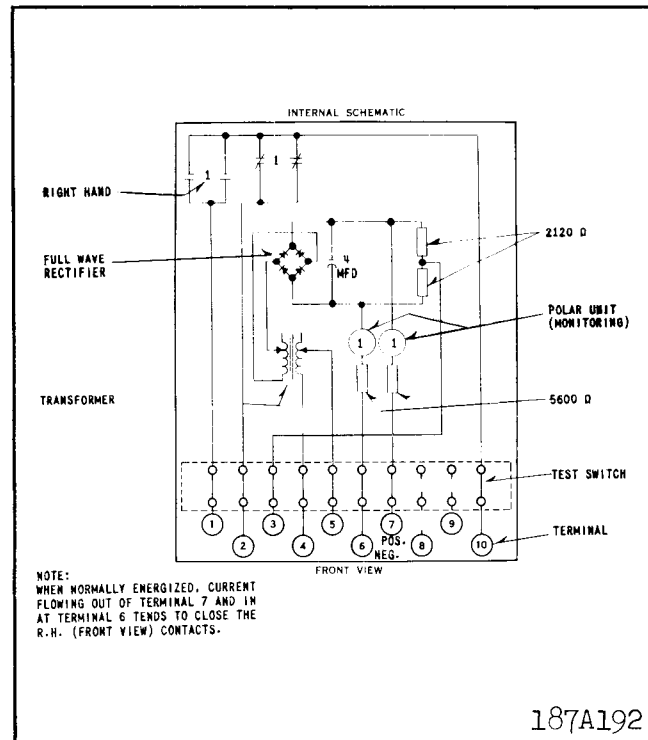

Fig. 5. Internal schematic of type PMA-1 relay in FT 21 case - 120 volt, 60 cycle supply - For three terminal lines.

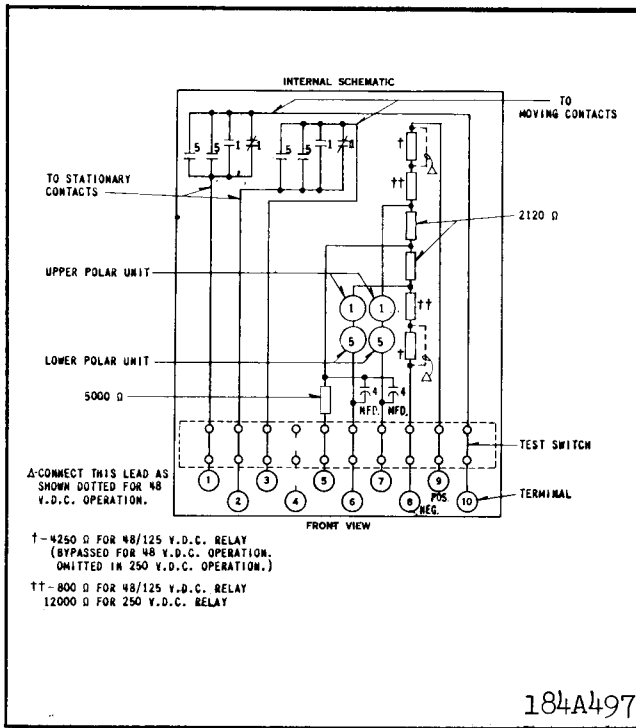

Fig. 6. Internal schematic of the type PMD relay in FT 21 case - DC supply - for two terminal lines.

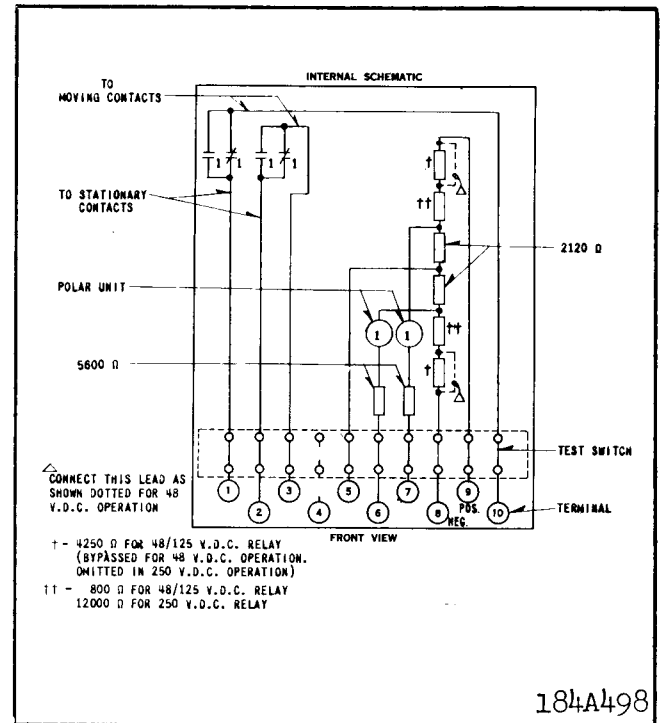

Fig. 7. Internal schematic of the type PMD-1 relay in the FT 11 case - DC supply - For two terminal lines.

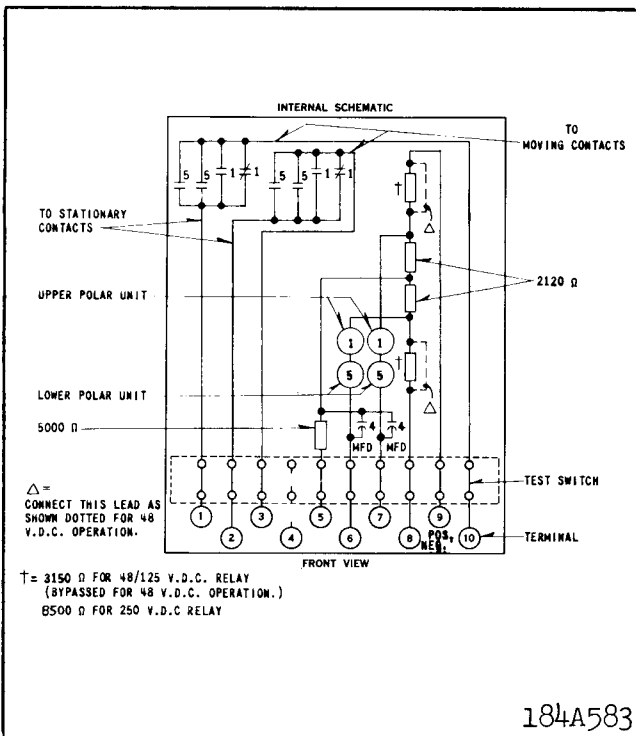

Fig. 8. Internal schematic of the type PMD relay in the FT 21 case - DC supply - For three terminal lines.

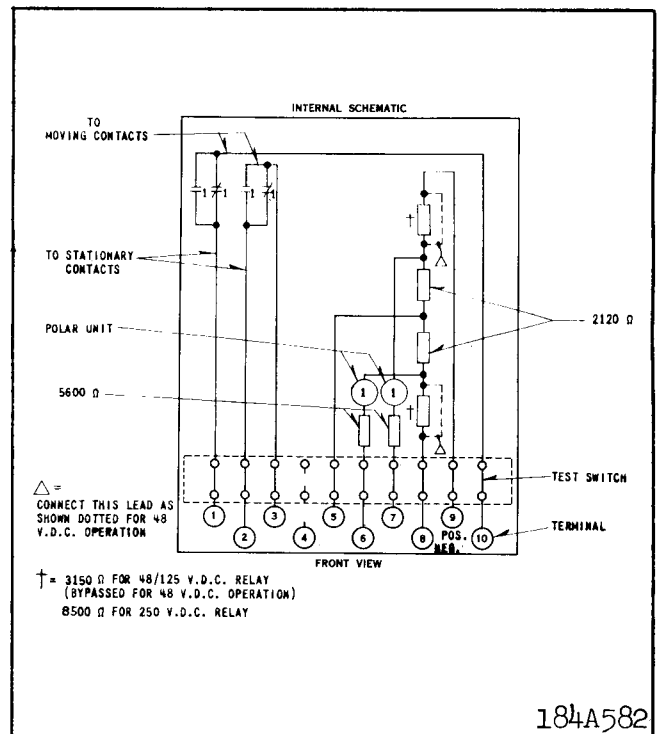

Fig. 9. Internal schematic of the type PMD-1 relay in the FT 11 case - DC supply - For three terminal lines.

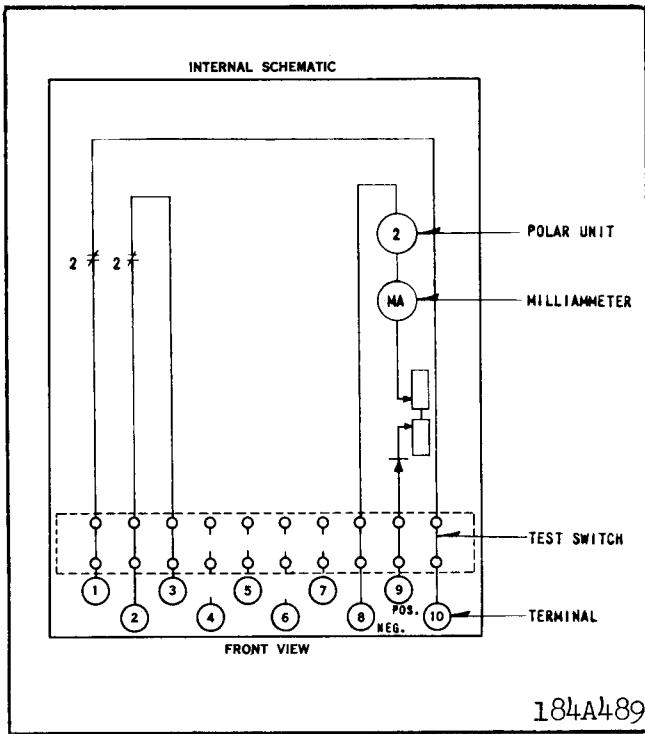

Fig. 10. Internal schematic of the type PM-2 relay in the FT 21 case.

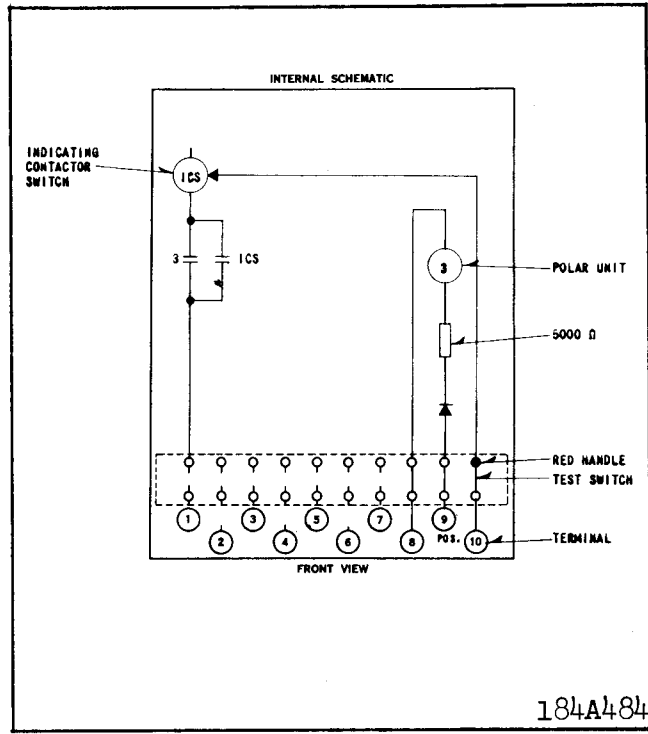

Fig. 11. Internal schematic of the type PM-3 relay in the FT 11 case.

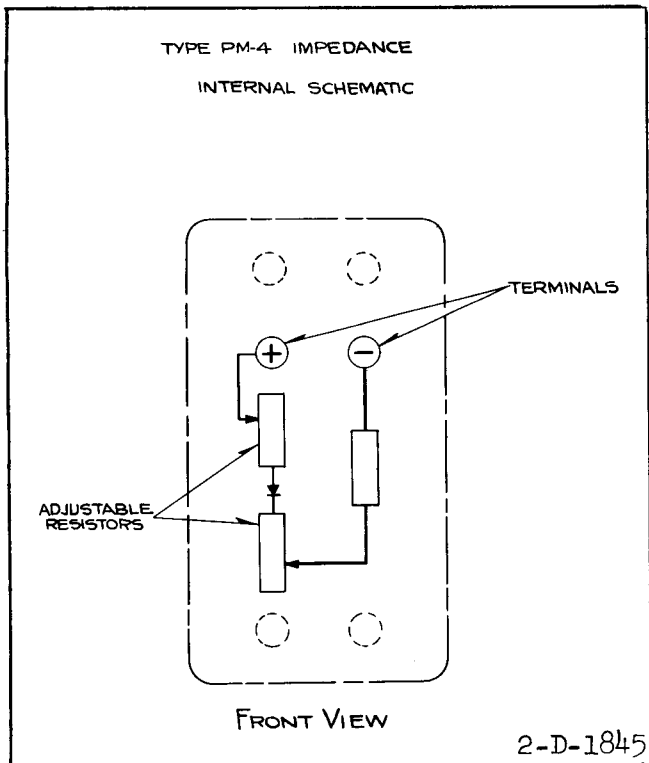

Fig. 12. Internal schematic of the type PM-4 Auxiliary Unit in the small molded case.

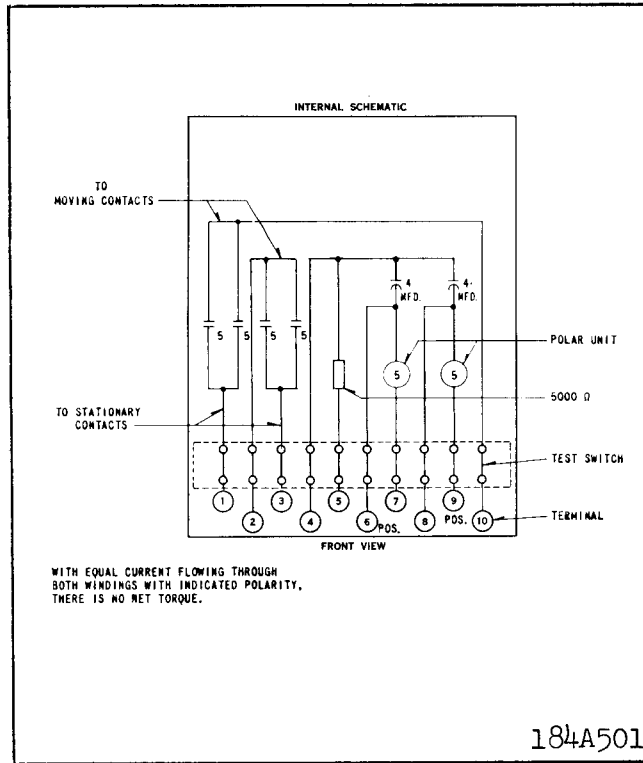
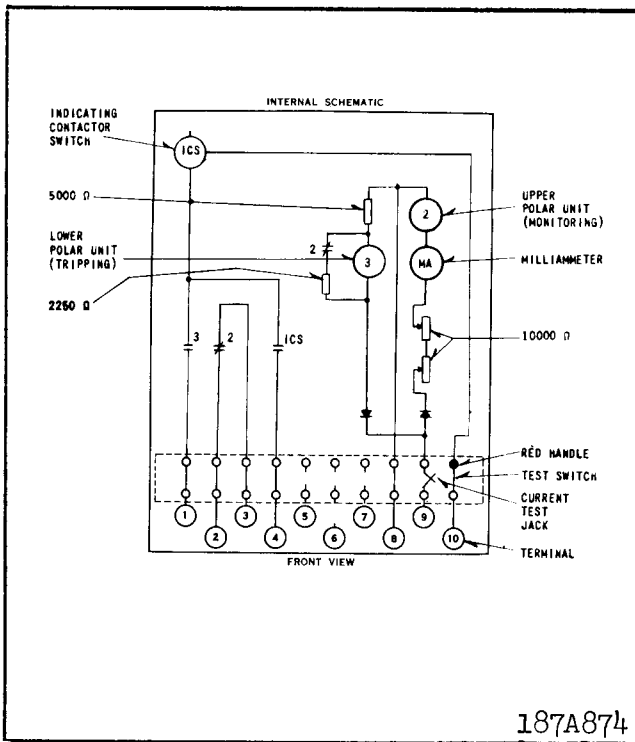
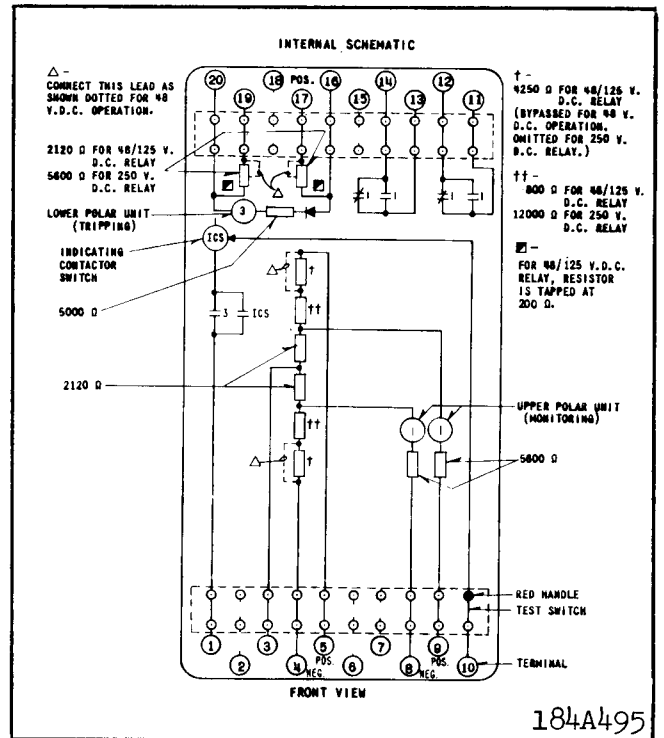

Fig. 13. Internal schematic of the type PM-5 ground detector relay in the FT 11 case.



187A874

Fig. 14. Internal schematic of the type PM-23 relay in the FT 21 case.



184A495

Fig. 15. Internal schematic of the type PM-13 relay in the FT 32 case - DC supply - For two terminal lines.

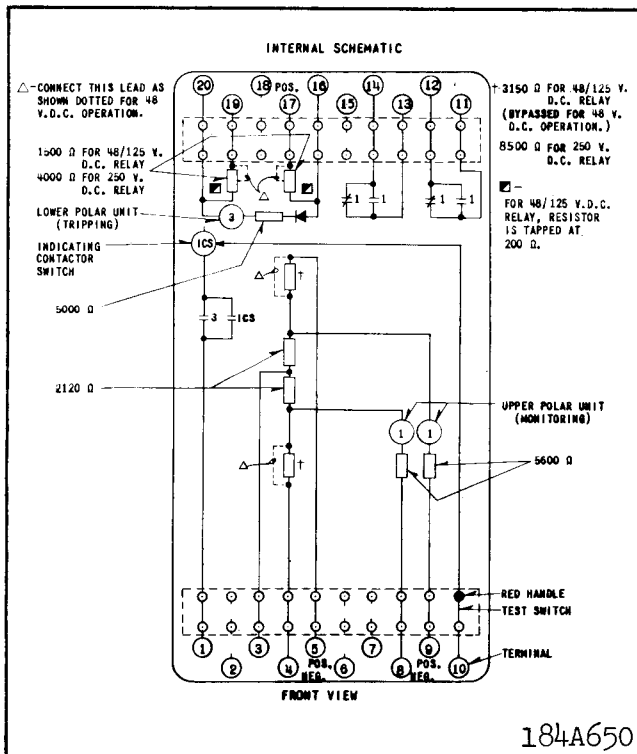

184A650

Fig. 16. Internal schematic of the type PM-13 relay in the FT 32 case - DC supply - For three terminal lines.

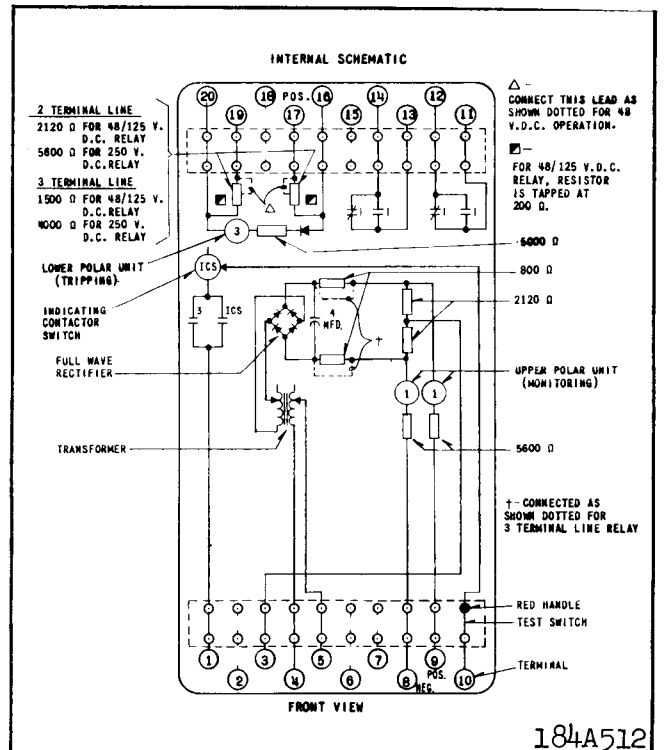

184A512

Fig. 17. Internal schematic of the type PM-13 relay in the FT 32 case - 120 volt, 60 cycle supply - For two or three terminal lines.

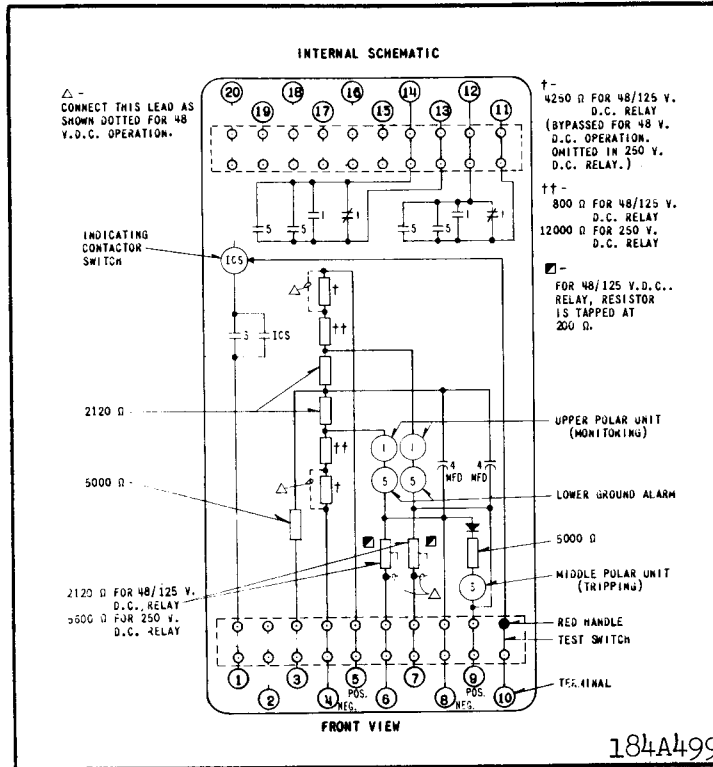

Fig. 18. Internal schematic of the type PMG-13 relay in the FT 32 case - DC supply - For two terminal lines.

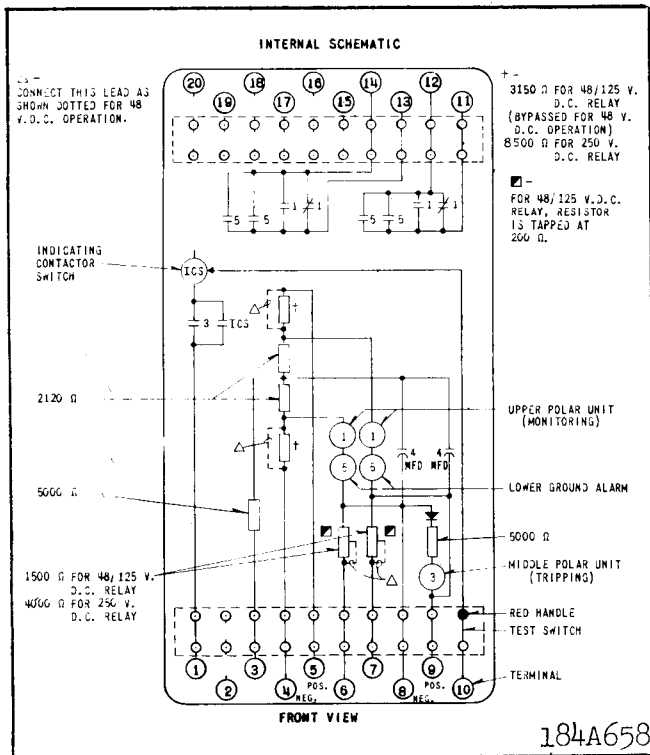

Fig. 19. Internal schematic of the type PMG-13 relay in the FT 32 case - DC supply - For three terminal lines.

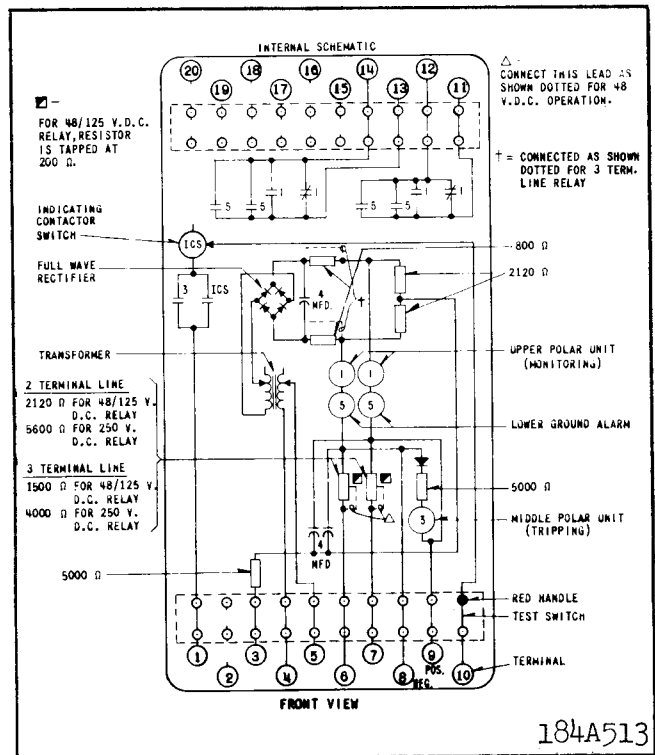
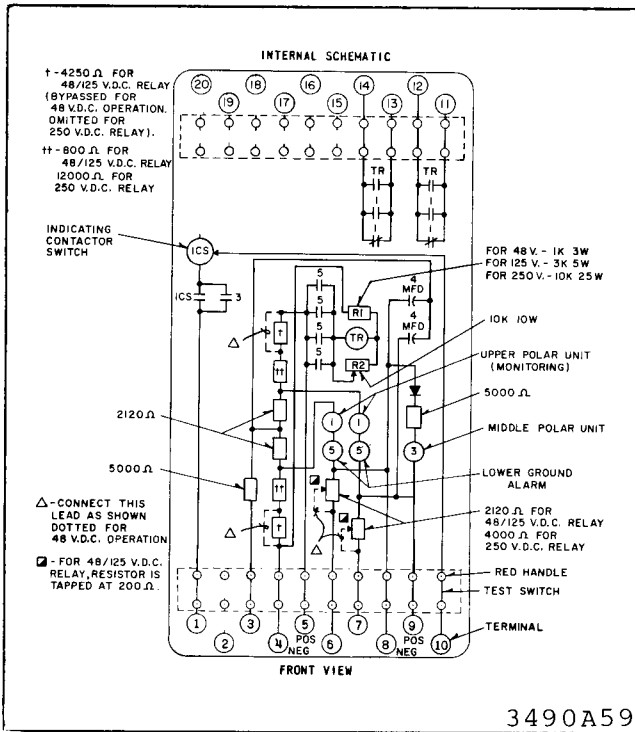
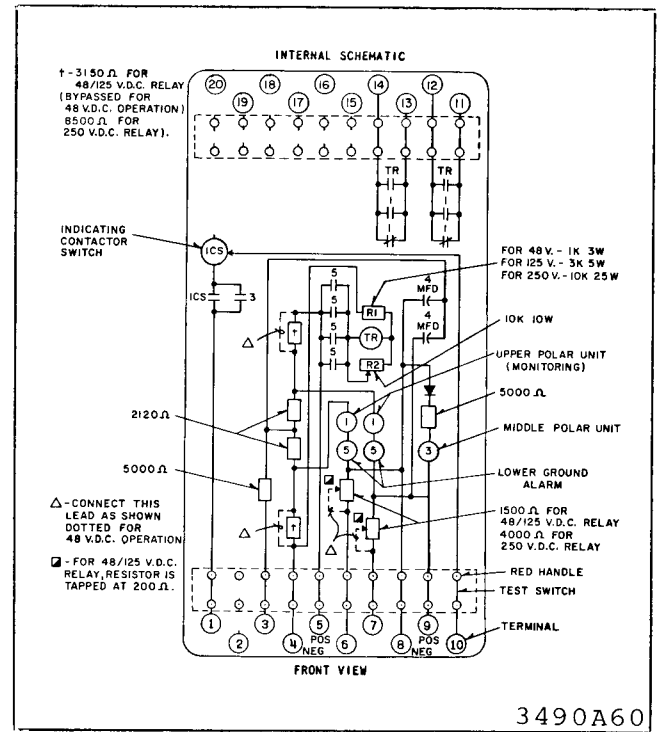

Fig. 20. Internal schematic of the type PMG-13 relay in the FT 32 case - 120 volt, 60 cycle supply - For two or three terminal lines.



* Fig. 21. PMG-13 Relay with Ground Alarm and Remote Trip - Two Terminal Lines with Telephone Relay Output. FT-32 Case.



* Fig. 22. PMG-13 Relay with Ground Alarm and Remote Trip - Three Terminal Lines with Telephone Relay Output - FT-32 Case.

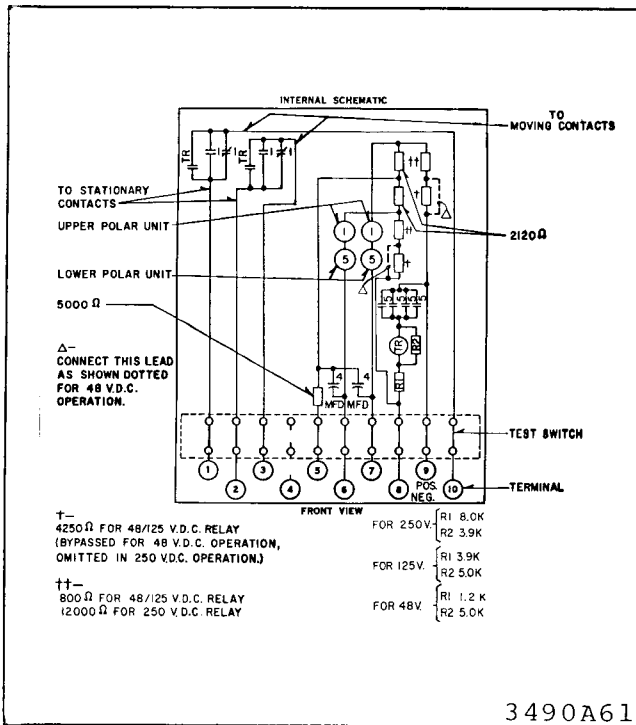

Fig. 23. PMD Relay - Ground Alarm, D.P.D.T. Contacts, Two Terminal Lines with Telephone Relay Output - FT-21 Case.

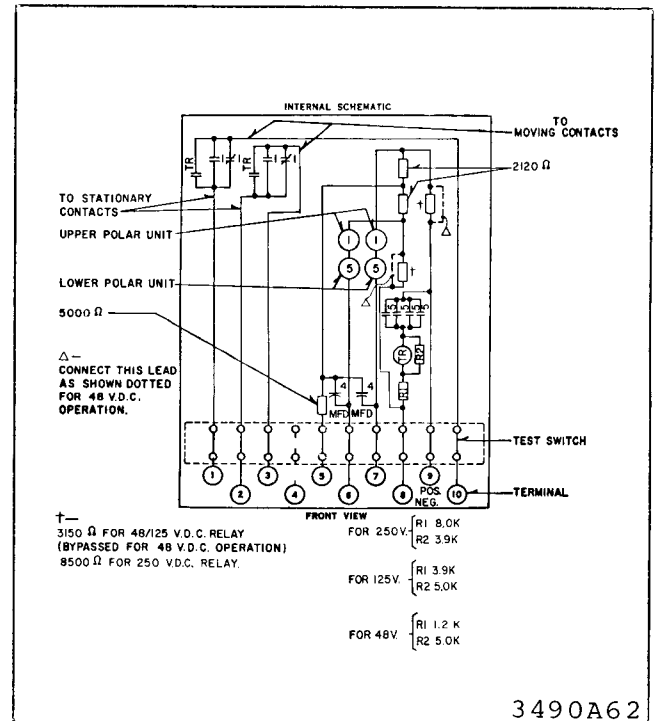

Fig. 24. PMD Relay - Ground Alarm, D.P.D.T. Contacts, Three Terminal Lines with Telephone Relay Output - FT-21 Case.

TYPE PM MONITORING RELAYS

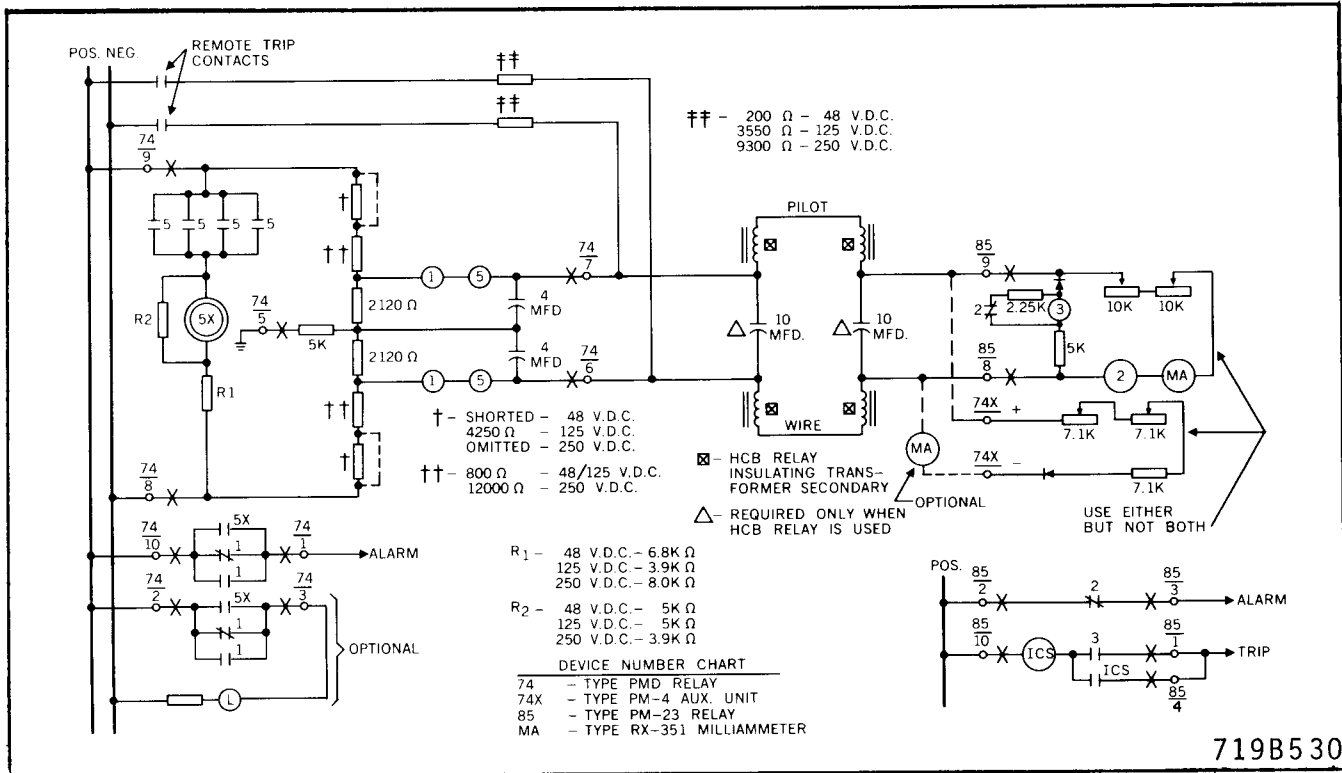

Fig. 25. External schematic of the type PMD relay with type PM-23 or PM-4 relay - Two terminal lines.

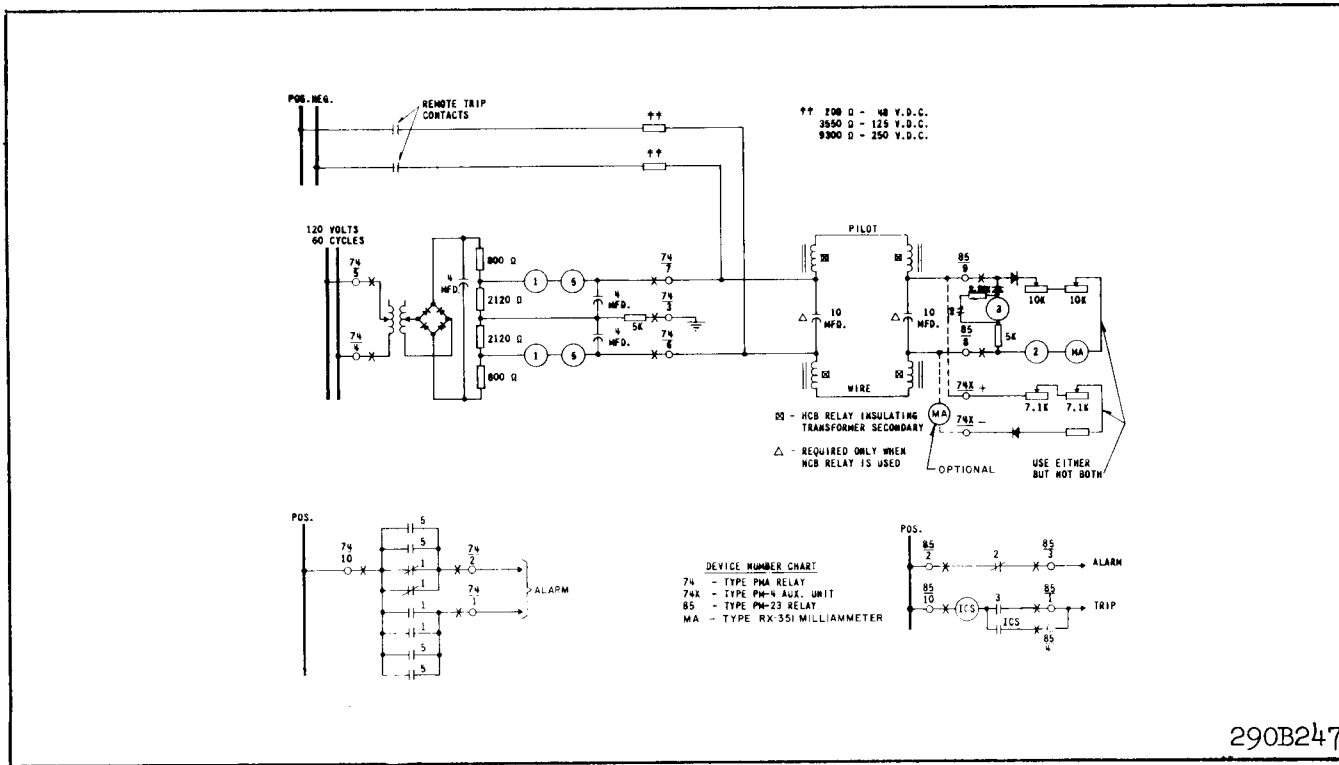

Fig. 26. External schematic of the type PMA relay with type PM-23 or PM-4 relay - Two terminal lines.

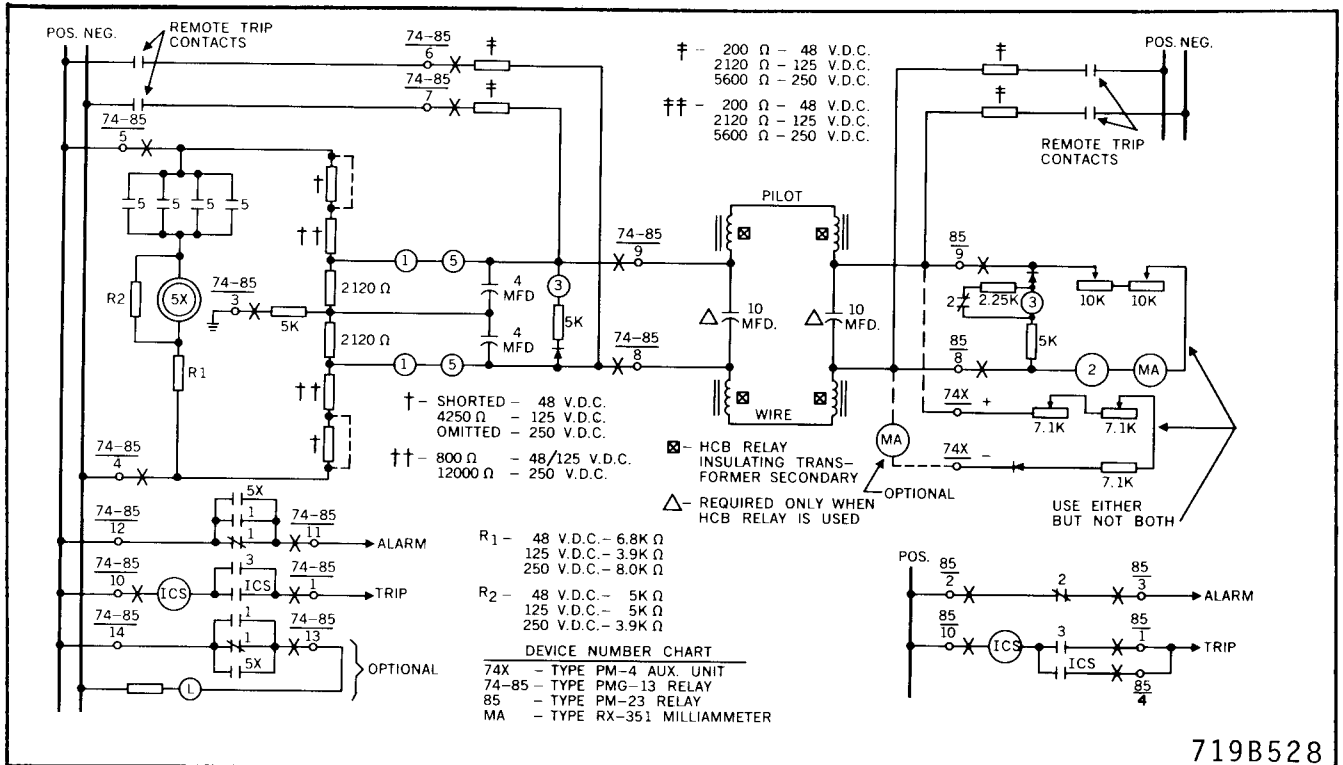

Fig. 27. External schematic of the DC type PMG-13 relay with type PM-23 or PM-4 relay - Two terminal lines.



Fig. 28. External schematic of the type PMD relay with type PM-23 and PM-4 relays - Three terminal lines.

TYPE PM MONITORING RELAYS

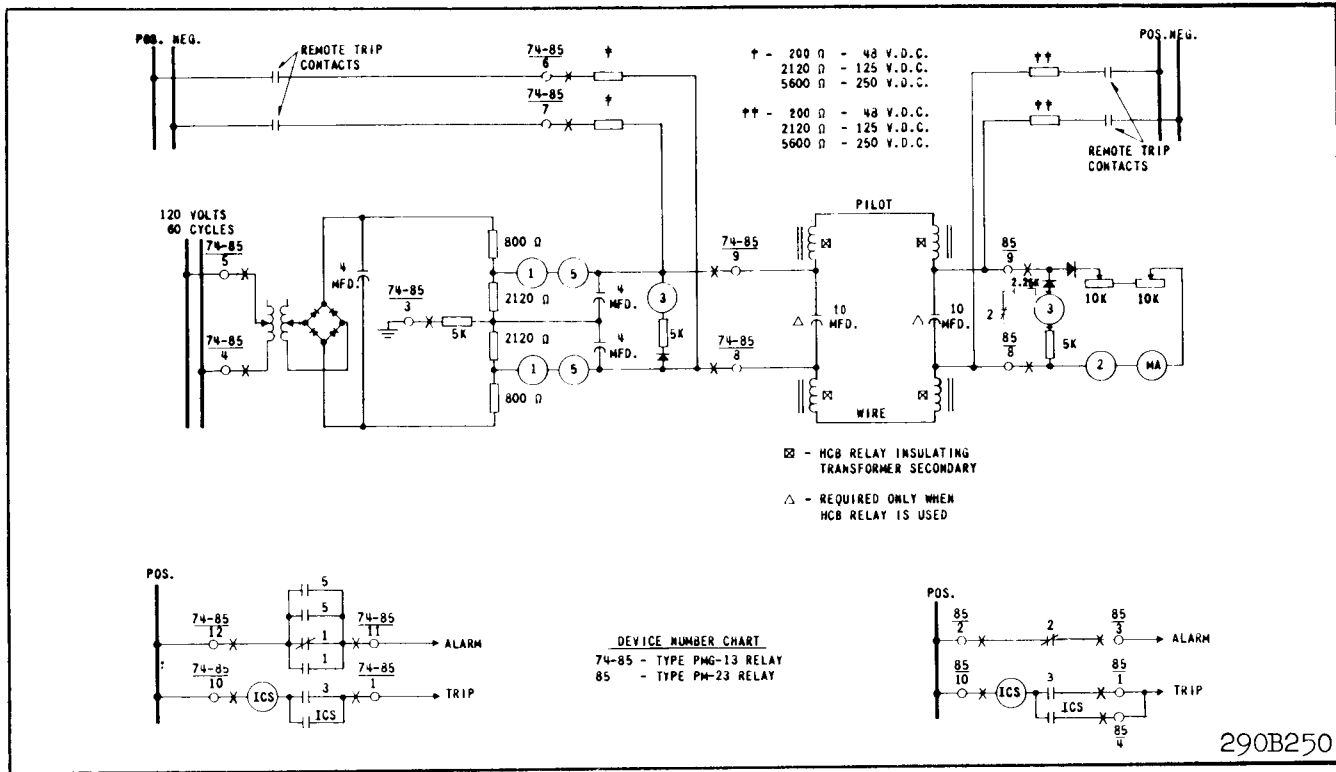

Fig. 29. External schematic of the AC type PMG-13 with type PM-23 relay - Two terminal lines.

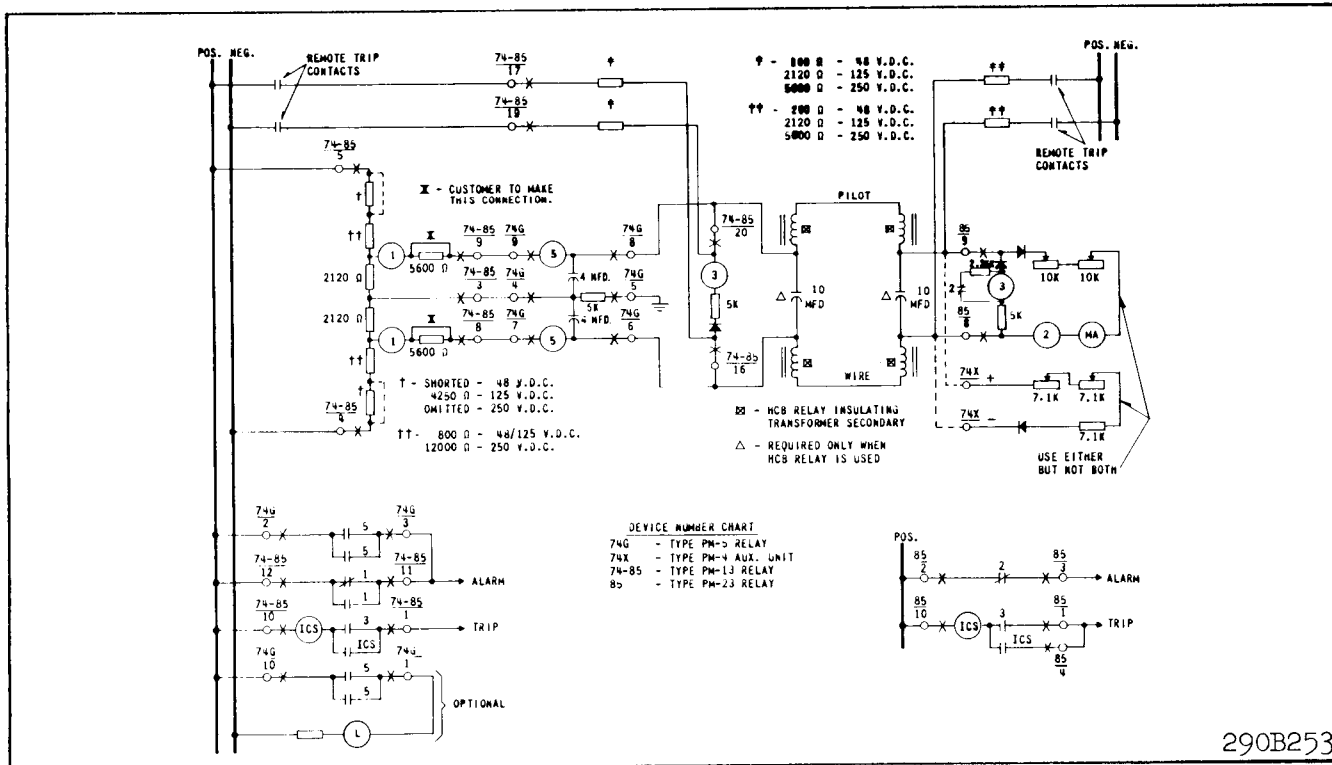

Fig. 30. External schematic of the DC type PM-13 and PM-5 relay with type PM-23 or PM-4 relay - Two terminal lines.

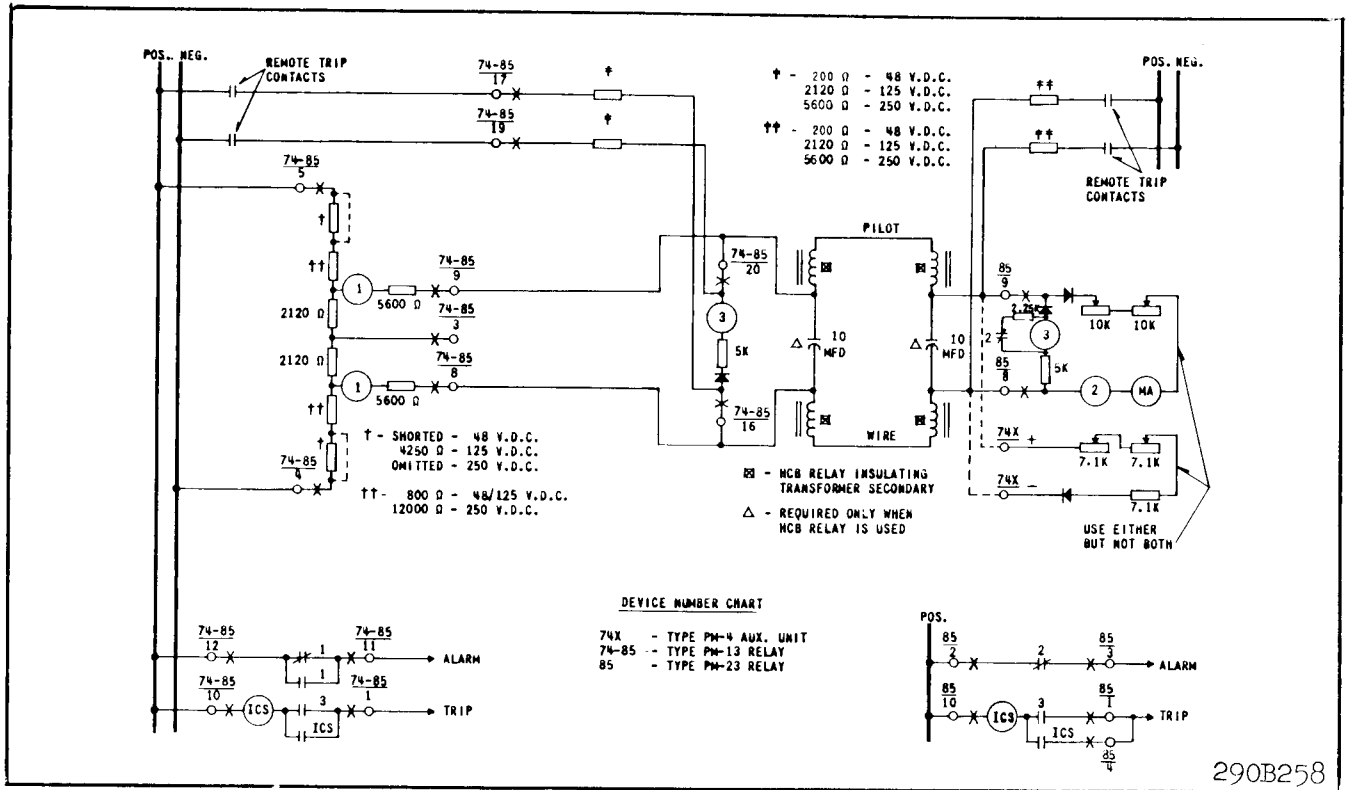

Fig. 31. External schematic of the DC type PM-13 relay with type PM-23 or PM-4 relay - Two terminal lines.

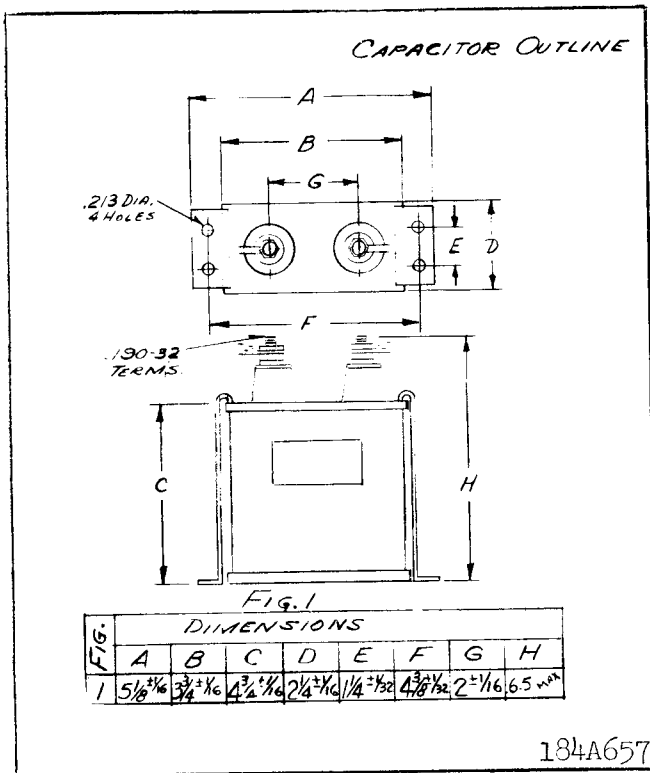

Fig. 32. Outline and Drilling Plan for 10 mfd. capacitor - For reference only.

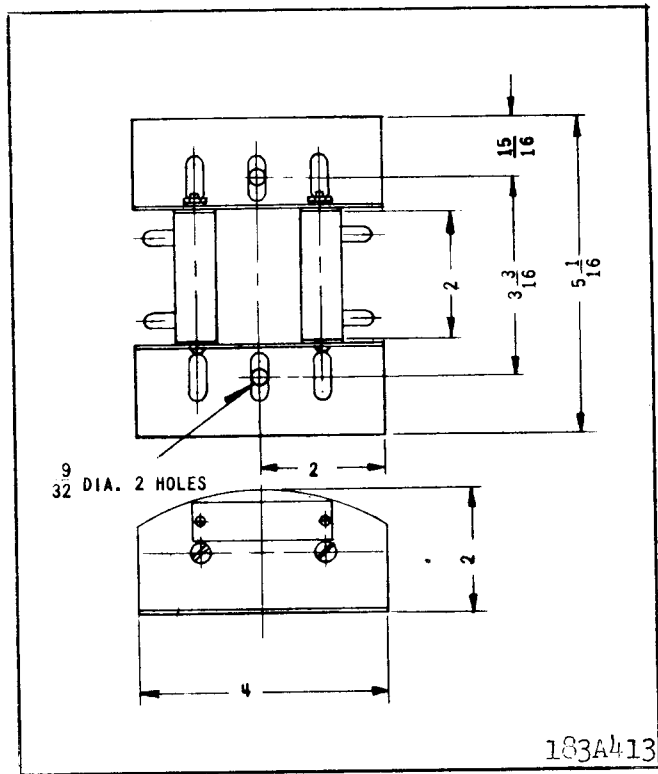

Fig. 33. Outline and Drilling Plan for External Remote trip Resistor Assembly.

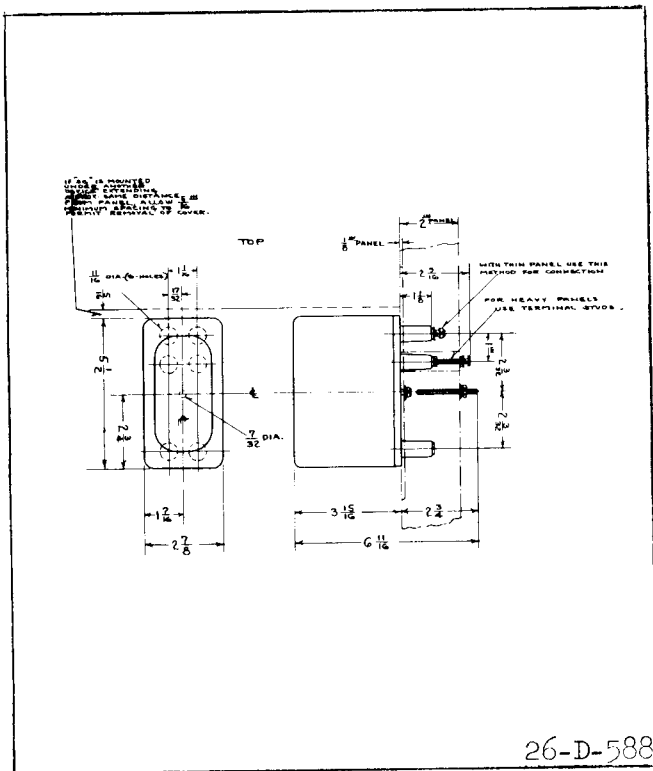

Fig. 34. Outline and Drilling Plan for the type PM-4 Auxiliary unit in the projection molded case.

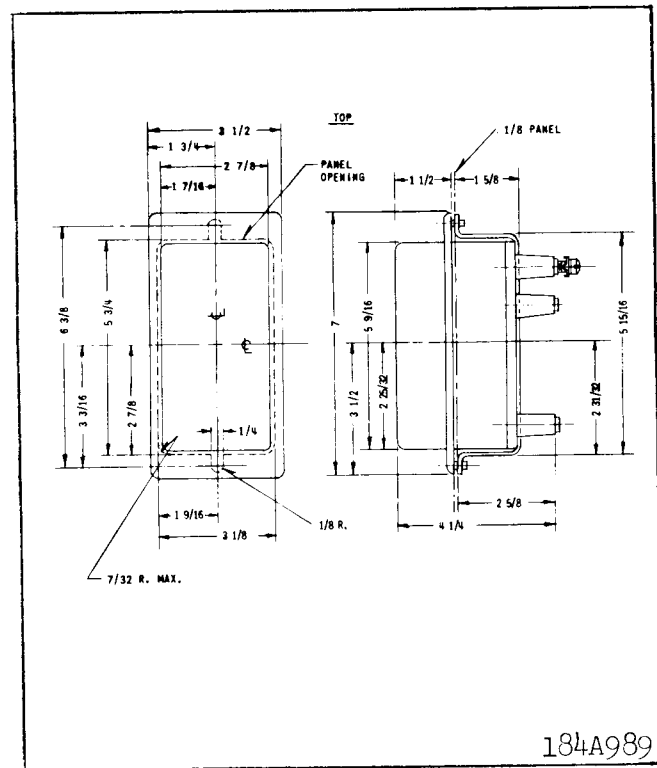

Fig. 35. Outline and Drilling Plan for the type PM-4 Auxiliary unit in the Semi-Flush molded case.

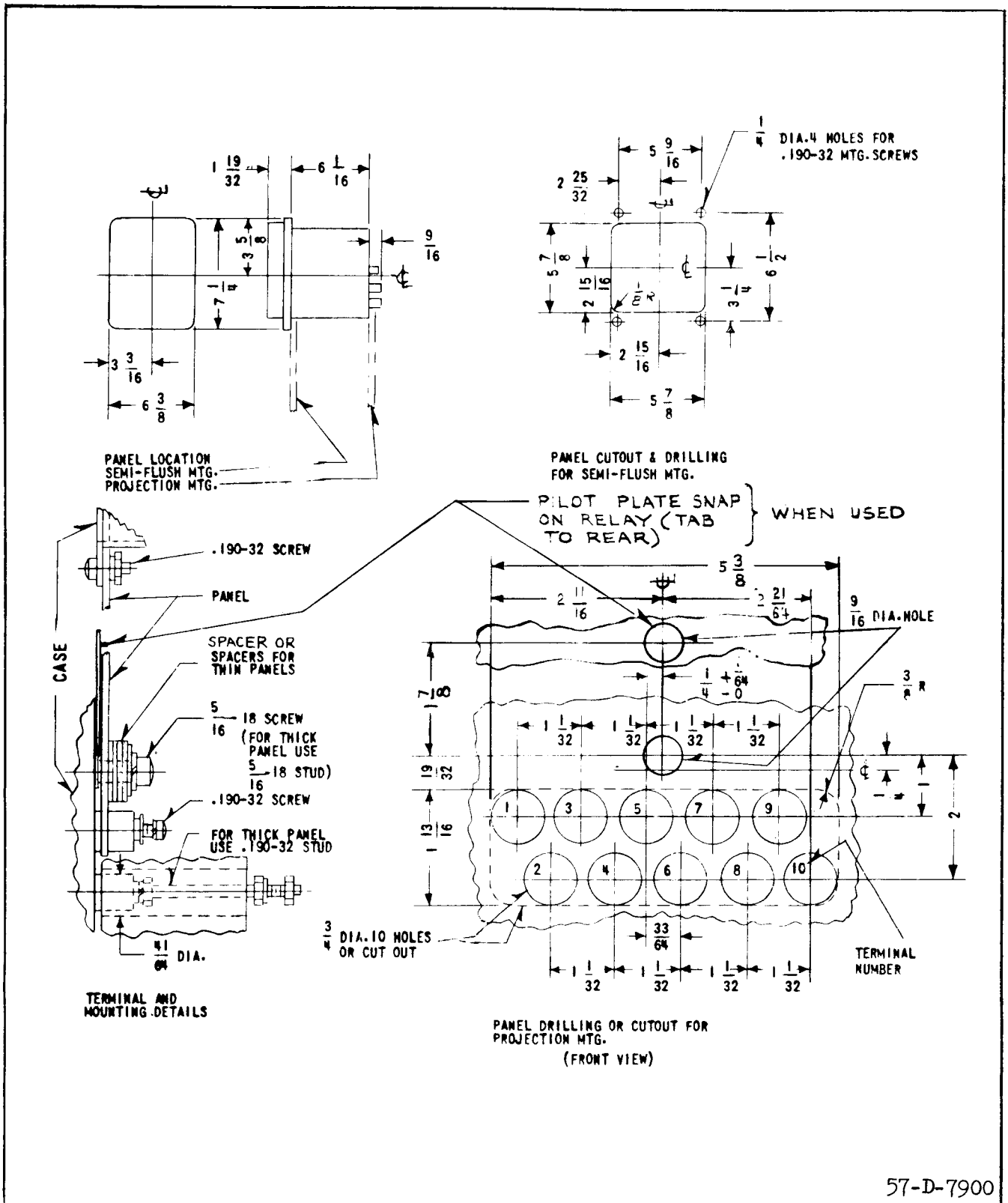

Fig. 36. Outline and Drilling Plan for the type PM-3, PM-5, & PMD-1 Relays in the type FT 11 case.

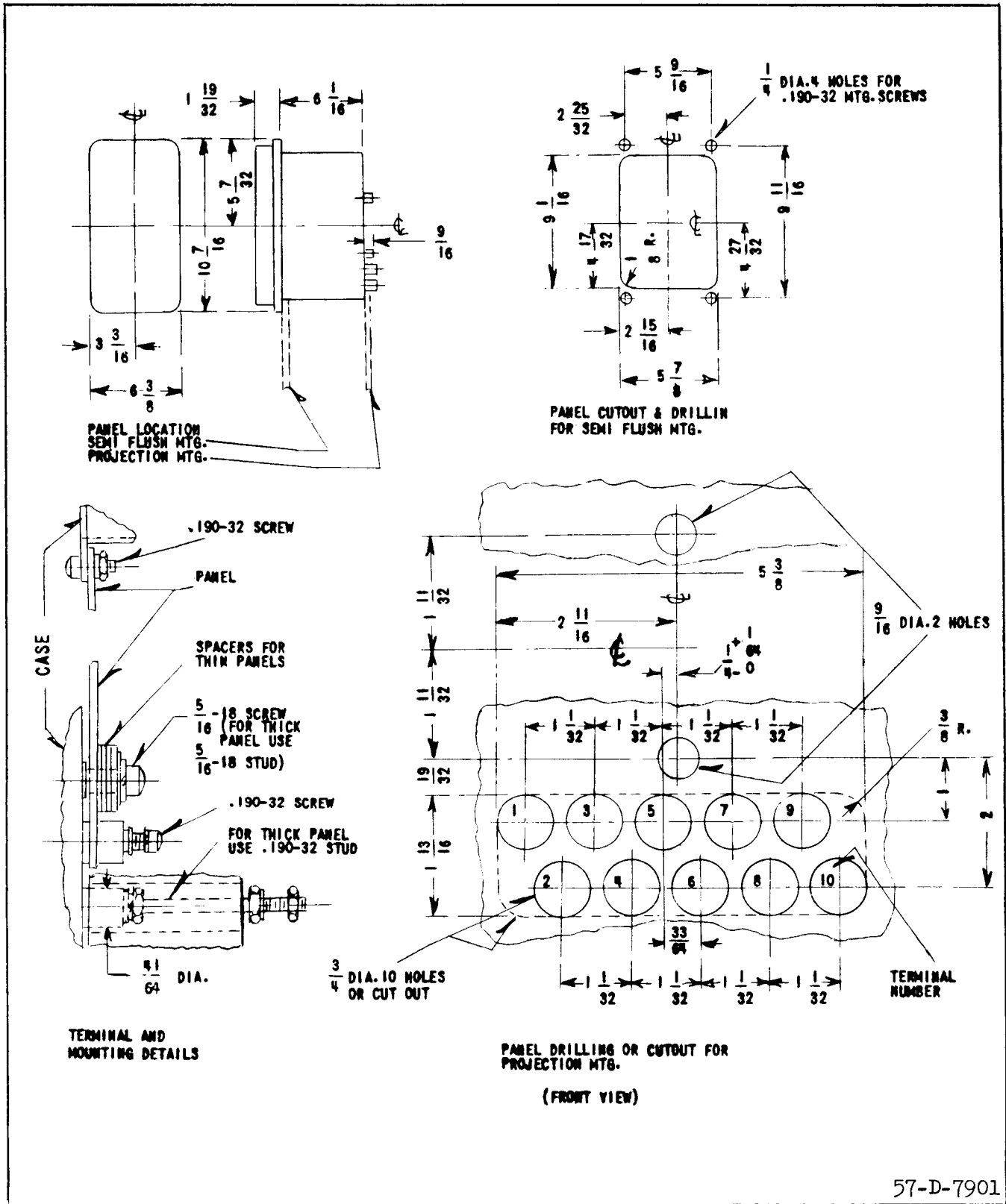
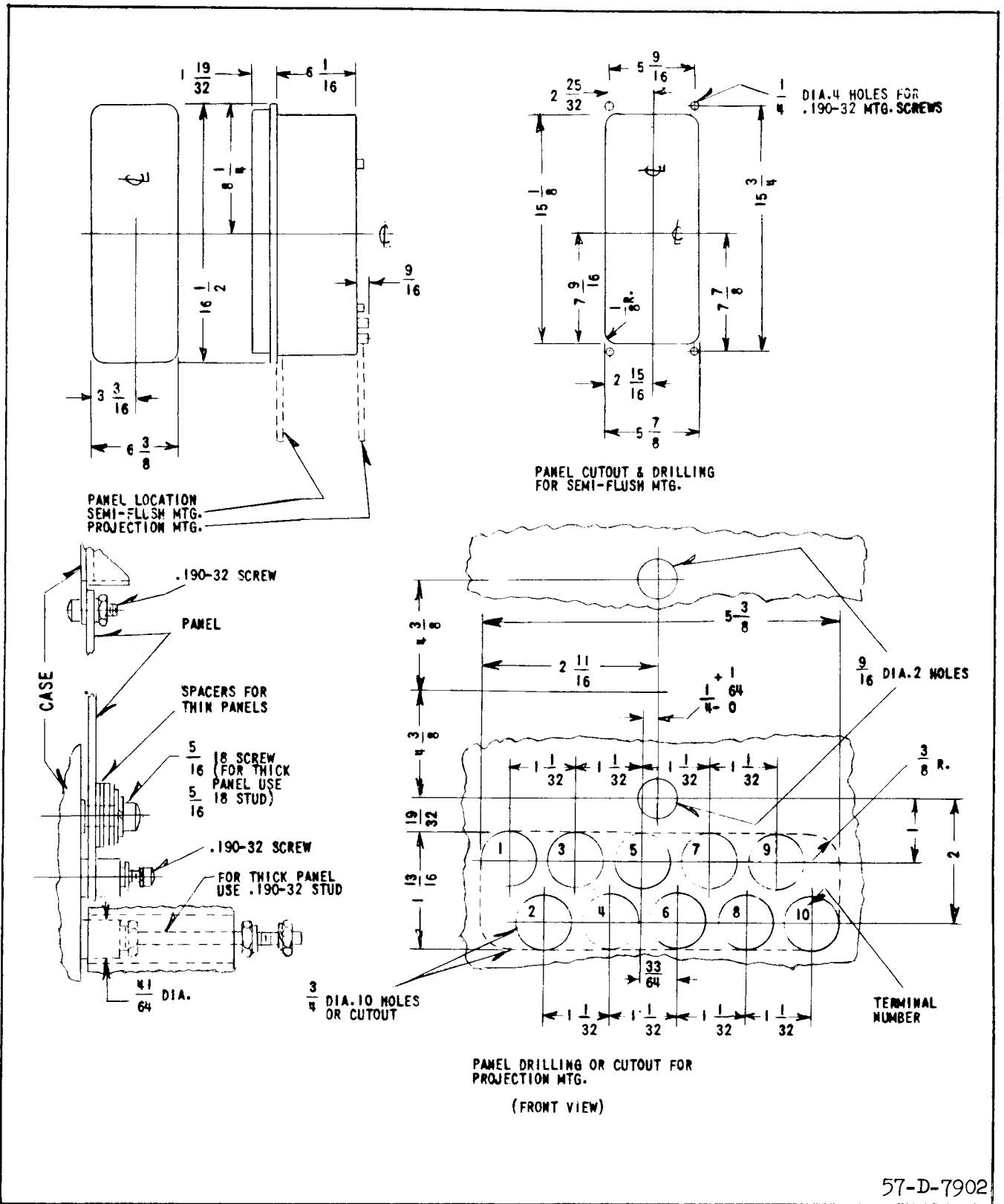

Fig. 37. Outline and Drilling Plan for the type PM-2, PM-23, PMA-1 and PMD relays in the type FT 21 case.



57-D-7902

Fig. 38. Outline and Drilling Plan for the type PMA relay in the type FT 31 case.

TYPE PM MONITORING RELAYS

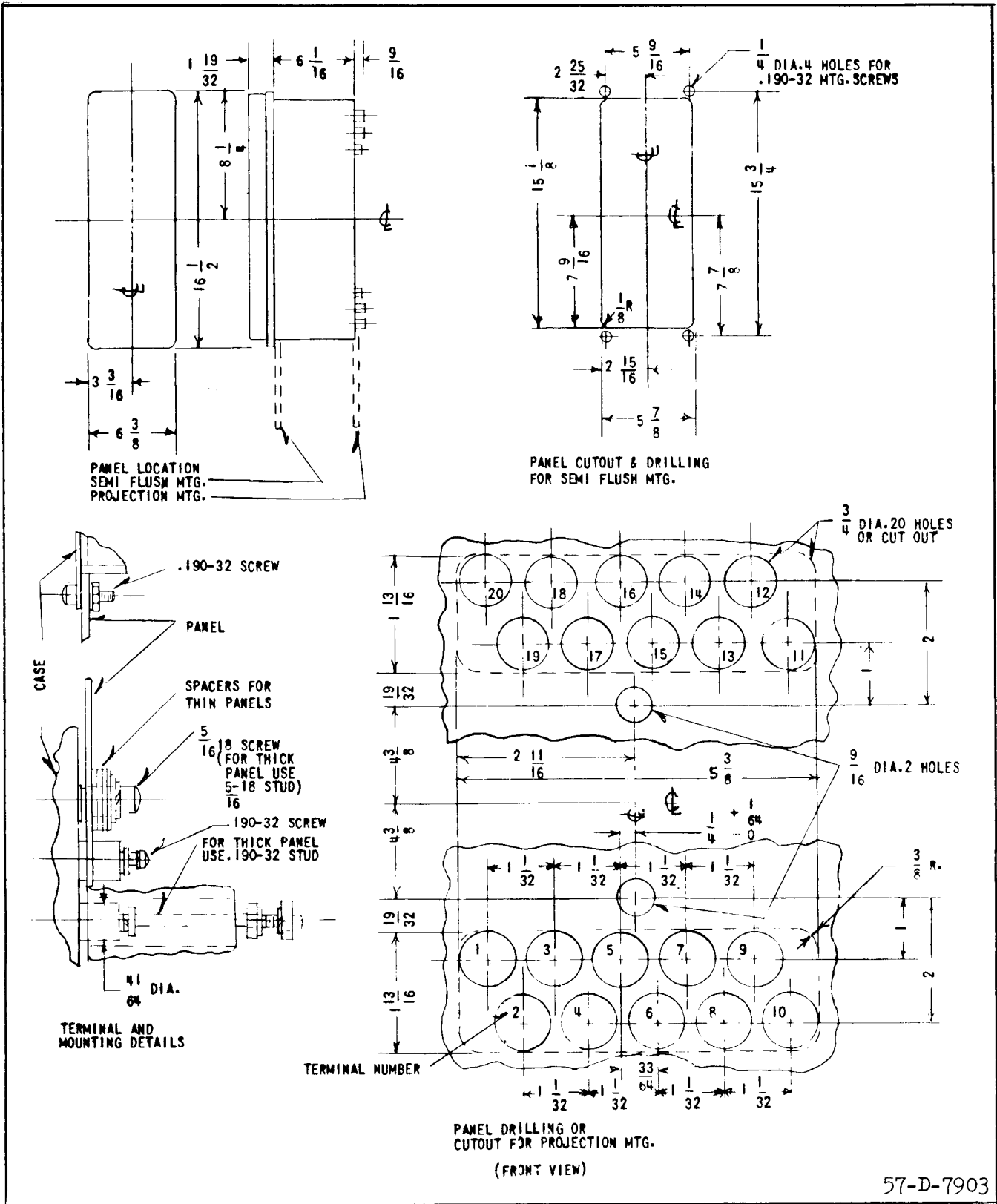
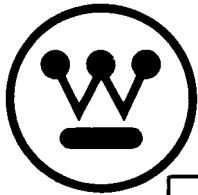

Fig. 39. Outline and Drilling Plan for the type PM-13 and PMG-13 relays in the type FT 32 case.

WESTINGHOUSE ELECTRIC CORPORATION
RELAY-INSTRUMENT DIVISION

NEWARK, N. J.

Printed in U.S.A.



INSTALLATION • OPERATION • MAINTENANCE I N S T R U C T I O N S

TYPE PM LINE OF RELAYS FOR PILOT-WIRE MONITORING AND TRANSFERRED TRIPPING

CAUTION Before putting protective relays into service, remove all blocking which may have been inserted for the purpose of securing parts during shipment, make sure that all moving parts operate freely, inspect the contacts to see that they are clean and close properly, and operate the relay to check the settings and electrical connections.

APPLICATION

Type PM Monitoring Relays provide continuous monitoring of a pilot-wire circuit to detect open circuits, short circuits, grounds, and wire reversal. In addition, transferred tripping can be effected where the PM-3, PM-13, PMG-13 or PM-23 relays are used. Table I illustrates the functions available with each relay. A 10 mfd. capacitor is supplied with each PM relay. This capacitor provides an a-c path between the two halves of the insulating transformer secondary windings as shown in Figs. 21 through 27.

Each circuit requires the following:

At one end to introduce monitoring current

One of the following:

For a-c Supply

For d-c Supply

PMA

PMD

PMA-1

PMD-1

PM-13 or PMG-13 (a.c.)

PM-13 or PMG-13 (d.c.)

At the other end to receive monitoring current (two-terminal line)

One PM-23 or PM-2 or PM-4

At the other ends to receive monitoring current (three-terminal line)

Two PM-23 or two PM-4 or two PM-2 or any combination of two of these relays.

CONSTRUCTION

PM relays consist of the following:

PMA

PMA-1

1-Polar Alarm Unit (1)

1-Polar Alarm Unit

1-Polar Ground Unit (5)
1-Tapped Transformer
1-Full-Wave Rectifier
3-4 mfd. Capacitors
1-Set of Potential
Dividing Resistors

PMD

1-Polar Alarm Unit (1)
1-Polar Ground Unit (5)
2-4 mfd. Capacitors
1-Set of Potential
Divider Resistors

PMG-13

1-Polar Alarm Unit (1)
1-Polar Ground Unit (5)
1-Polar Trip Unit (3)
1-Indicating Contactor
Switch
1-Set of Potential
Divider Resistors
1-Tapped Transformer
(A.C. Relay only)
1-Full-Wave Rectifier
(A.C. Relay only)
1-Blocking Rectifier
2-Remote Trip Resistors
3-4 mfd. Capacitors
(A-C Relay)
2-4 mfd. Capacitors
(D-C Relay)

PM-23

1-Polar Alarm Unit (2)
1-Polar Trip Unit (3)
1-Indicating Contactor
Switch (ICS)
1-Milliammeter, 5.0 ma.
1-Set of Adjustable and
Fixed Resistors
2-Blocking Rectifiers

1-Tapped Transformer
1-Full-Wave Rectifier
1-4 mfd. Capacitor
1-Set of Potential
Dividing Resistors

PMD-1

1-Polar Alarm Unit
1-Set of Potential
Divider Resistors

PM-13

1-Polar Alarm Unit (1)
1-Polar Trip Unit (3)
1-Indicating Contactors
Switch
1-Set of Potential
Divider Resistors
1-Tapped Transformer
(A.C. Relay only)
1-Full-Wave Rectifier
(A.C. Relay only)
1-Blocking Rectifier
2-Remote Trip Resistor
1-4 mfd. Capacitor

PM-2

1-Polar Alarm Unit (2)
1-Milliammeter, 5.0 ma.
1-Set of Adjustable
Resistors
1-Blocking Rectifier

TYPE PM MONITORING RELAYS

PM-3

- 1-Polar Trip Unit (3)
- 1-Resistor
- 1-Blocking Rectifier
- 1-Indicating Contactor Switch (ICS)

PM-4

- 1-Blocking Rectifier
- 1-Set of Adjustable & Fixed Resistors

PM-5

- 1-Polar Ground Unit (5)
- 2-4 mfd. Capacitors
- 1-Fixed Resistor

TABLE I

FUNCTION	PMA & PMD	PMA-1 & PMD-1	PM-13	PMG-13	PM-23	PM-2	PM-3	PM-4	PM-5
Monitoring Current Source	X	X	X	X					
Receives Monitoring Current					X	X		X	
Trouble Alarm	X	X	X	X	X	X			X
Transmits Trip Signal	X †	X †	X	X	X †	X †	X †	X †	
Receives Trip Signal			X	X	X		X		
Sensitive Ground Detection	X			X					X
Measures Monitoring Current					X	X			

† With External Resistors

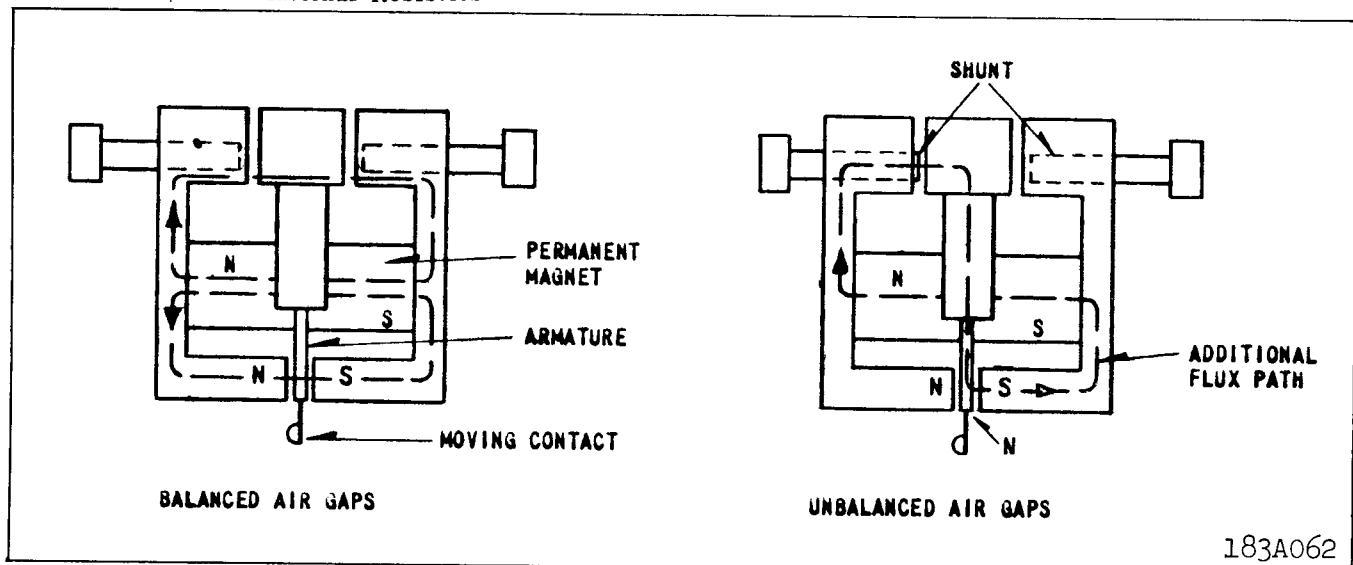

Fig. 1. Polar Unit Permanent Magnet Flux Paths.

Polar Unit

The polar unit consists of a rectangular shaped magnetic frame, an electromagnet, a permanent magnet, and an armature. The poles of the crescent shaped permanent magnet bridge the magnet frame. The magnetic frame consists of three pieces joined in the rear with two brass rods and silver solder. These non-magnetic joints represent air gaps, which are bridged by two adjustable magnetic shunts. The winding or windings are wound around a magnetic core. The armature is fastened to this core and is free to move in the front air gap. The moving contact is connected to the free end of a leaf spring, which, in turn, is fastened to the armature.

Indicating Contactor Switch

The d-c indicating contactor switch is a small clapper type device. A magnetic armature, to which leaf-spring mounted contacts are attached, is attracted to the magnetic core upon energization of the switch. When the switch closes, the moving contacts bridge two stationary contacts, completing the trip circuit. Also during this operation two fingers on the armature deflect a spring located on the front of the switch, which allows the operation indicator target to drop. The target is reset from the outside of the case by a push rod located at the bottom of the cover.

The front spring, in addition to holding the target, provides restraint for the armature and thus controls the pickup value of the switch.

- * **PMD & PMG13 with Tel. Relay:** In the relays type PMD and PMG13 where they are energized with DC power supply, the ground polar unit (#5) could momentarily close its contact (for about 10 m.s.) if either positive or negative supply is grounded. To eliminate this momentary operation, a telephone relay with a nominal operating time of 25 m.s. was connected in series with contact of the "5" unit, and the contact of the telephone relay is used as an overall contact output of the "5" unit. This type of relay should be used where the DC power supply is subjected to short to the ground.

OPERATION

Pilot Wire Monitoring

Monitoring current is introduced into the pilot wire as shown in the external schematics, figures 21 to 27, by the monitoring current source. External schematics showing other combinations are available on request. A nominal 20 volts is impressed across the 10 mfd. capacitor at the left-hand line terminal in Figures 21 to 27. This voltage produces a current circulating through one winding of the HCB insulating transformer, one pilot wire, the PM-23, PM-2, or PM-4,

and back through the other pilot wire and the other winding of HCB insulating transformer.

Adjustment of the resistors of the PM-23, PM-2 or PM-4 relay at the other end of the pilot wire provides a normal one-milliampere d-c circulating current. In the case of three-terminal lines, the monitoring source relay output current is 2 ma. in order to provide each receiving end relay with 1 ma. The alarm unit of the monitoring current source relay is adjusted to float between the high and low current contacts with normal monitoring current. The PM-23, receiving-end alarm relay, is adjusted to float between the low-current alarm contact and a contact stop with 1 ma. flowing.

Short Circuits

A complete or partial short circuit on the pilot wires increases the current in the current-source relay, causing the high-current alarm contacts to close. The resulting current decrease in the PM-23 relay closes the alarm contact. Short circuits of 5000 ohms or less will be detected.

Open Circuits

Current decreases to zero in all relays. Low-current alarm contact of the current source relay closes. Alarm contact of PM-23 relay closes.

Reversed Wires

On applications using the PM-23 relay, current increases in the sending end relay to close the high-current alarm contacts. Current drops to zero in the PM-23 relay monitoring coil to close the low-current alarm contacts.

If the pilot wire should be opened and reclosed with reversed connections when the PM-23 relay is in service, the alarm contact (2) in the PM-23 drops out. The alarm contact dropping out shunts the trip unit coil (3), and prevents the trip unit contact (3) from operating momentarily. The trip unit contact is prevented from operating because the capacitor at the sending end discharges through the pilot wire and the trip unit (3) circuit. This will have no effect on remote trip operation.

The current decreases in both sending and receiving end relays when the PM-2, or PM-4 relays are used. Low current alarm contacts close.

Grounds

The voltage-divider circuit of the PMA, PMD, and PMG-13 source relays has its midpoint grounded through a current-limiting resistor. Thus, a pilot-wire ground will cause an increase in current in one coil circuit, and a decrease in the other one. This unbalance in the current flowing through the two windings (5) of the ground alarm relay unit will cause it to close one of its contacts (depending on which pilot

TYPE PM MONITORING RELAYS

wire is grounded) to give an alarm. Grounds of 10,000 ohms or less will be detected.

For adding the sensitive ground detection where PMA-1, PMD-1, or PM-13 relays have been installed, the PM-5 relay can be added to the circuitry, as shown in figure 24. This relay also has a 10,000-ohm ground sensitivity.

Transferred Tripping

Breakers located at the PMG-13 or PM-13 and PM-3 or PM-23 stations can be tripped by the application of a d-c voltage to the pilot wires at remote locations, as shown in figures 21 to 27. Transferred tripping can be effected from any location by applying 48 volts d-c (through dropping resistors when required) to the pilot wire with polarity opposite to that of the monitoring voltage. When tripping the PM-23, the current is increased above 2.0 ma, in reverse direction, to close the trip contact. When tripping the PMG-13 or PM-13, the reversed d.c. voltage operates the trip unit (3).

See Tables II and III for tripping resistor values. Nominal tripping currents is 5ma. at all rated voltages.

Polar Unit

Polar unit flux paths are shown in figure 1. With balanced air gaps, permanent magnet flux flows in two paths, one through the front, and one through the rear gaps. This flux produces north and south poles, as shown. By turning the left shunt in, some of the flux is forced through the armature, making it a north pole. Thus, reducing the left hand rear gap will produce a force tending to pull the armature to the right. Similarly, reducing the right hand gap will make the armature a south pole and produce a force tending to pull the armature to the left.

The alarm unit contacts of the sending and receiving end relays are biased to move to the left when the relay is deenergized. The PMG-13 or PM-13 and PM-23 trip unit contact is biased to move to the left when the relay is deenergized. The PM-5 is adjusted so that the moving contact floats when the relay is deenergized.

CHARACTERISTICS

Nominal Calibration Values

Nominal current values to close contacts are listed in Tables IV and V.

Voltage Ratings

Supply voltage ratings of the monitoring source relays to obtain continuous monitoring current are as follows:

DC - 48, 125, and 250 volts

AC - 120 volts, 60 cycles (Primary taps 100, 110, 120 & 130)

Voltage impressed on the pilot wire is a nominal 20 volts for monitoring, and 48 volts for tripping.

Supply voltage ratings to obtain remote tripping are: 48, 125, and 250 volts d-c.

Coil Resistance (each winding)

Alarm coil (1)	
two terminal line	1050-1250 ohms
three terminal line	700-900 ohms
Alarm coil (2)	2200-2600 ohms
Trip coil (3)	1800-2200 ohms
Ground Alarm coil (5)	5200-5800 ohms

PM-4 and PM-23 Resistance

Nominal PM-4 and PM-23 total resistance when adjusted for service is 20,000 ohms less pilot wire loop resistance at 1 ma.

PMA, PMA-1 and AC PMG-13, PM-13 Burden

0.5 VA at tap voltage	-	2-terminal line relay
1.0 VA at tap voltage	-	3-terminal line relay

Rectifiers

Approximate forward resistance -	560 ohms at 1 ma
	300 ohms at 2 ma

Rating

Continuous forward	
current - amperes	- 1
Continuous back	
voltage - rms volts	- 200

Remote Tripping

Remote trip resistors are listed in Table II and III for 48, 125, and 250 volts d-c.

The relays have sufficient thermal capacity to withstand 20 MA d-c continuously when remote tripping. Nominal trip currents in the tripping relays are 5.0 MA d-c with 48, 125, and 250 volts d-c supply and a 2000-ohm pilot wire.

TABLE II

PMA, PMA-1, PMD, AND PMD-1 APPLICATIONS
EXTERNAL RESISTORS FOR D.C. REMOTE TRIPPING
(2 REQUIRED PER STATION)

# LINE TERMINALS	D.C. VOLTAGE	STATION A PMA or PMA-1	STATION A PMD or PMD-1	STATION B PM-2 & PM-3 or PM-23 or PM-4	STATION C PM-2 & PM-3 or PM-23 or PM-4	TO OPERATE
2	48	200	200	—	—	PM-23 or PM-3
	125	3550	3550	—	—	"
	250	9300	9300	—	—	"
3	48	200	200	—	—	"
	125	2000	2000	—	—	"
	250	5600	5600	—	—	"

TABLE IIIA

PMG-13 AND PM-13 (D.C. SUPPLY) APPLICATIONS
RESISTORS FOR D.C. REMOTE TRIPPING
(2 REQUIRED PER STATION)

# LINE TERMINALS	D.C. VOLTAGE	STATION A PMG-13 or PM-13	STATION B PM-2 & PM-3 or PM-23 or PM-4	STATION C PM-2 & PM-3 or PM-23 or PM-4	TO OPERATE
2	48	200 †	200	—	PMG-13 or PM-13 and PM-23 or PM-3
	125	2120 †	2120	—	"
	250	5600 †	5600	—	"
3	48	200 †	200	200	"
	125	1500 †	1500	1500	"
	250	4000 †	4000	4000	"

† Mounted in Relay

TABLE IIIB

PMG-13 AND PM-13 (A.C. SUPPLY) APPLICATIONS
(2 REQUIRED PER STATION)
RESISTORS FOR D.C. REMOTE TRIPPING

# LINE TERMINALS	D.C. VOLTAGE	STATION A PMG-13 or PM-13	STATION B PM-2 & PM-3 or PM-23 or PM-4	STATION C PM-2 & PM-3 or PM-23 or PM-4	TO OPERATE
2	48	200 †	200	—	PMG-13 or PM-13 and PM-23 or PM-3
	125	2120 †	2120	—	"
	250	5600 †	5600	—	"
3	48	200 †	200	200	"
	125	1500 †	1500	1500	"
	250	4000 †	4000	4000	"

† Mounted in Relay

TABLE IV

NOMINAL CALIBRATION VALUES – TWO TERMINAL LINES

<u>RELAY</u>	<u>LOW CURRENT ALARM</u> ¹	<u>HIGH CURRENT ALARM</u> ²	<u>TRIP</u>
PMA or PMA-1	0.7 ma	1.3 ma	—
PMD or PMD-1	0.7	1.3	—
PM-5 †	—	±0.3	—
PMG-13 or PM-13	0.7 ††	1.3 ††	14 V.
PM-23 or PM-2 & PM-3 †	0.7	—	14 V.

† Same relay as for three-terminal lines

†† These are pilot-wire current values

1 – Left-hand contacts, front view.

2 – Right-hand contacts, front view.

TABLE V

NOMINAL CALIBRATION VALUES – THREE TERMINAL LINES

<u>RELAY</u>	<u>LOW CURRENT ALARM</u>	<u>HIGH CURRENT ALARM</u>	<u>TRIP</u>
PMA or PMA-1 •	1.7 ma	2.3 ma	—
PMD or PMD-1	1.7	2.3	—
PM-5 †	—	±0.3	—
PMG-13 or PM-13	1.7 ††	2.3 ††	14 V.
PM-23 or PM-2 & PM-3 †	0.7	—	14 V.

† Same relay as for two-terminal lines

†† These are pilot-wire current values

Trip Circuit

The main contacts will safely close 30 amperes at 250 volts d-c and the seal-in contacts of the indicating contactor switch will safely carry this current long enough to trip a circuit breaker.

The indicating contactor switch has two taps that provide a pickup setting of 0.2 or 2 amperes. To change taps requires connecting the lead located in front of the tap block to the desired setting by means of a screw connection.

Trip Circuit Constant

Indicating Contactor Switch (ICS)

0.2 ampere tap 6.5 ohms d-c resistance

2.0 ampere tap 0.15 ohms d-c resistance

SETTING THE RELAY

Operating units of all relays are adjusted in the factory to the values listed in Tables IV and V to a tolerance of ±5%. No settings are required on these units.

For all 48/125-volt d.c. relays, connect jumpers across resistors as shown on the internal schematics.

PM-4, PM-2, and PM-23 Relays

Adjust the resistors in the PM-4, PM-2, or PM-23 relay or relays to a value of 1MA d-c with the monitoring circuits connected for service. Use the milliammeter in the PM-23 for this purpose or use a portable milliammeter with a resistance of less than 200 ohms. Where it is not practical on three-terminal lines to adjust both receiving relays simultaneously, set one receiving relay for 18,000 ohms total resistance (including relay coil and resistors) by measurement prior to final adjustment of the other receiving relay. This procedure will minimize the change in monitoring current in the first relay to be adjusted when making the final adjustment of the second relay.

PMA, PMA-1, PMG-13 and PM-13 Relays

Select the transformer tap nearest to expected normal a-c supply voltage. The full wave rectifier is

connected to a secondary transformer tap. Where desired, the output voltage can be raised about 5% by reconnecting across the full secondary winding.

Indicating Contactor Switch

No setting is required on the ICS unit except the selection of the 0.2 or 2.0 ampere tap setting. This selection is made by connecting the lead located in front of the tap block to the desired setting by means of the connecting screw. When the relay energizes a type WL relay switch, or equivalent, use the 0.2 ampere tap.

INSTALLATION

The relays should be mounted on switchboard panels or their equivalent in a location free from dirt, moisture, excessive vibration, and heat. Mount the relay vertically by means of the four mounting holes on the flange for semi-flush mounting or by means of the rear mounting stud or studs for projection mounting. Either a mounting stud or the mounting screws may be utilized for grounding the relay. The electrical connections may be made directly to the terminals by means of screws for steel panel mounting or to the terminal studs furnished with the relay for thick panel mounting. The terminal studs may be easily removed or inserted by locking two nuts on the stud and then turning the proper nut with a wrench.

For detailed FT case information, refer to I.L. 41-076.

Where the potential to ground impressed on the relays can exceed 700 volts, a drainage reactor in conjunction with a KX-642 tube, or the reactor in conjunction with 700 volt carbon-block arresters, is recommended. For details, see Protection of Pilot-Wire Circuits, AIEE Committee Report, paper 58-1190, AIEE Transactions, 1959, Volume 78, Part III B pp. 205-212. Also, see AIEE Special Publication S-117, Applications and Protection of Pilot-Wire Circuits for Protective Relaying, July 1960.

ADJUSTMENTS AND MAINTENANCE

The proper adjustments to insure correct operation of this relay have been made at the factory and should not be disturbed after receipt by the customer. If the adjustments have been changed, the relay taken apart for repairs, or if it is desired to check the adjustments at regular maintenance periods, the instructions in the succeeding sections should be followed.

Acceptance Tests

The following tests are recommended when the relay is received from the factory. If the relay does not perform as specified below, the relay either is not properly calibrated or it contains a defect.

Indicating Contactor Switch (ICS)

Close the contact of the tripping unit and pass sufficient direct current through the trip circuit to close the contacts of the ICS unit. This value of current should not be greater than the particular ICS tap setting being used (0.2 or 2.0). The indicator target should drop freely.

PMA and PMA-1 Relays

Alarm Unit (1)

Set the primary tap on 120 volts. Connect a variable resistor of approximately 20,000 ohms in series with a low-range d-c milliammeter across terminals 6 and 7 with the instrument positive connected to terminal 7. Apply 120 volts at rated frequency to terminals 4 and 5. Adjust the 20,000-ohm resistor to obtain a current of one ma. d.c. For a three-terminal line relay, use a 10,000-ohm resistor and set the current to 2 ma. d.c. At this value, the moving contact of the alarm or monitoring relay unit (1) should float between the two sets of stationary contacts. In the PMA relay, the ground alarm unit (5) contact should also float. (This contact will also float when the relay is de-energized.) Increase and decrease the one or two-milliamper monitoring current to check the calibration values listed in Tables IV and V.

Ground Unit (5)

Reconnect the 20,000-ohm resistor. For the PMA relay only, short terminals 7 and 3. The contact of the ground alarm unit (5) should close to the right when the relay is energized. Remove the short, and connect it between terminals 6 and 3. The ground alarm unit (5) should close to the left. The action of the monitoring unit (1) contact is of no significance in this simulated pilot-wire ground test. To check the pickup current of the ground detector, first remove the 20,000-ohm resistor from terminals 6 and 7. Connect a 0-1 d.c. milliammeter in series with a variable resistor of about 50,000 ohms between terminals 3 and 6. The ground unit should close its left-hand contact at approximately 0.3 ma. d.c. With the milliammeter and resistor connected between terminals 3 and 7, the right-hand contact should close at 0.3 ma. d.c.

TYPE PM MONITORING RELAYS

PMD and PMD-1 Relays

Alarm and Ground Units

Connect an adjustable 20,000-ohm resistor (or 10,000-ohms for a 3-terminal relay) in series with a d-c milliammeter across terminals 6 and 7 with the instrument positive connected to terminal 7. Apply rated d-c voltage to terminals 8 and 9 with positive on terminal 9. Now check the PMD and PMD-1 relays, following the procedure given in the previous section for the PMA and PMA-1 relays, respectively. Note, however, that terminal 5 of the PMD relay corresponds to terminal 3 of the PMA relay.

PM-2, PM-3, and PM-23 Relays

Alarm Unit (2)

Apply a variable d-c voltage of approximately 20 volts to relay terminals 8 and 9 (terminal 9 positive) of the PM-2 or PM-23 relay. Adjust the voltage to obtain a reading of one ma. on the relay milliammeter. The monitoring polar unit (2) contacts should float. Reduce the current gradually. The monitoring alarm contacts should close at 0.7 ma. d.c. The tripping unit (3) of the PM-23 relay should not move during this test. The milliammeter has been adjusted to read 1 ma. $\pm 5\%$. As a result the pointer may not read zero for a zero current condition.

Tripping Unit (3)

To check the PM-3 relay or the tripping unit of the PM-23 relay, apply the variable d-c voltage in series with an external milliammeter to relay terminals 8 and 9 with terminal 8 positive for the PM-23 relay, or terminal 9 positive for the PM-3 relay. When checking the pickup of the PM-23 trip unit block open the alarm unit contacts (2) so as to remove the shunt resistor from around the trip coil (3).

The tripping relay unit (3) should pick up with positive action at 14 volts d.c. and should drop out at approximately 10 volts. The alarm unit of the PM-23 relay will not operate during this test.

PM-4 Relay

This device is simply a set of resistors and a diode to connect into the pilot-wire circuit to provide a path for the monitoring current. The resistors can be checked with an ohmmeter, and the diode can be checked either with an ohmmeter, or as explained in the section entitled "Rectifier Check" under "Routine Maintenance". If an ohmmeter is used, the difference in forward and reverse resistance readings obtained will be dependent on the current flowing through the diode.

PM-5 Relay

Apply 5 volts d.c. in series with a 0-1 d.c. milliammeter and a 20,000-ohm variable resistor to terminals 6 and 7 with positive on terminal 6. The left-hand contact should close at approximately 0.3 ma. Now apply the same circuit to terminals 8 and 9 with positive on terminal 9. The right-hand contact should close at approximately 0.3 ma.

PM 13 Relays - A.C. and D.C.

Alarm Unit (1)

Connect a variable 20,000-ohm resistor (10,000 ohms for a 3-terminal-line relay) in series with a d-c milliammeter across terminals 8 and 9 with the instrument positive on terminal 9. For the a-c relay, set the primary tap on 120 volts. Now apply the rated supply voltage to terminals 4 and 5. This will be 48, 125, or 250 volts d.c., or 120 volts a.c. as indicated on the relay nameplate. Adjust the variable resistor to obtain a current of one ma. for a 2-terminal line relay, or 2 ma. for a 3-terminal relay. At this value, the moving contacts of the alarm or monitoring (1) relay unit (the upper polar unit) should float between the two sets of stationary contacts. Increase and decrease the one or 2 ma. monitoring current to check the calibration values listed in Tables IV and V.

Tripping Unit (3)

To check the operation of the tripping unit 3 (the lower polar unit), apply a d.c. potential across terminals 16 (positive) and 20 (negative). The tripping polar unit should pick up at 14 volts, and should drop out at approximately 10 volts. The resistance of the series dropping resistors for transferred tripping (listed in Tables III A and III B) can be checked with an ohmmeter. The circuit location of these resistors can readily be seen from the external schematic, Figure 27.

PMG-13 Relays - A.C. and D.C.

Alarm and Tripping Units

Follow the procedure given in the previous section for the a-c. and d-c. PM-13 relays.

Ground Unit (5)

Connect the 20,000-ohm (or 10,000-ohm) resistor and milliammeter across terminals 8 and 9. With rated voltage applied and one ma. (or 2 ma.) flowing, successively short circuit terminals 3 and 8, then 3 and 9. The ground alarm unit 5 (lower polar unit) should move first to the left, then to the right. To check the pickup current of the ground detector, first remove the 20,000-ohm resistor from terminals 8 and 9. Connect a 0-1 d.c. milliammeter in series

with a variable resistor of about 50,000 ohms between terminals 3 and 8. The left-hand contact should close at approximately 0.3 ma. d.c. With the milliammeter resistor connected, between terminals 3 and 9, the right-hand contact should close at 0.3 ma. d.c. The external schematic diagrams for these relays are shown in Figure 23 and 25.

Routine Maintenance

CAUTION - Do not make any performance check, calibration tests, or adjustments while the PM relays are energized or connected to the pilot wires, to prevent the possibility of inadvertently causing a break operation. The PM relays may be removed from service for testing, without jeopardizing HCB relay protection, providing that the connections between the 10-mfd capacitor and the HCB insulating transformer are not disturbed.

Contacts

All contacts should be periodically cleaned. A contact burnisher S#182A836H01 is recommended for this purpose. The use of abrasive material for cleaning contacts is not recommended because of the danger of embedding small particles in the face of the soft silver and thus impairing the contact.

Operational Check

In addition to cleaning contacts, it is recommended that an operational check be performed periodically by opening and short-circuiting the pilot wires, as well as grounding them at the relay terminals. **Note:** These pilot-wire faults should not be applied directly to the pilot wires when the HCB relays are in service. It is also recommended that the trip circuits of the PM relays be opened (where tripping is used), to prevent the possibility of inadvertently tripping the associated circuit breaker during testing. If the relays do not perform as expected, and diode failure is suspected, the diode tests described in the following section may be performed.

Rectifier (Diode) Check

If there is suspicion of a rectifier (diode) failure, apply 30 volts d.c. reverse voltage (positive on arrow-head) through a 300-ohm resistance to the diode. Measure the voltage across the diode. If this voltage is not essentially 30 volts, the diode is short-circuited. Now apply 30 volts d.c. in the forward direction through the 300-ohm resistor, and measure the voltage across the resistor. If the voltage is not essentially 30 volts, the diode may have a high forward resistance. If the voltage is zero, the diode is open-circuited.

Calibration

If the relay has been dismantled or the calibration has been disturbed, use the following procedure for calibration.

With the permanent magnet removed, see that the moving armature floats in the central area of the air-gap between the poles of the polar unit frame. If necessary, loosen the core screw in the center rear of the unit and shift the core and contact assembly until the armature floats. (This can best be done with the polar unit removed from the relay.) Then retighten the core screw and replace the permanent magnet with the dimple (north pole) on the magnet to the left when viewed from the front.

Polar Units-General

The following mechanical adjustments are given as a guide, and some deviation from them may be necessary to obtain proper electrical calibration.

Magnetic Shunt Adjustment

The sensitivity of the polar unit is adjusted by means of two magnetic, screw-type shunts at the rear of the unit, as shown in Fig. 1. These shunt screws are held in proper adjustment by a flat strip spring across the back of the polar unit frame, so no locking screws are required. Looking at the relay, front view turning out the right-hand shunt to open the right-hand air gap decreases the amount of current required to close the right-hand contact. Conversely, drawing out the left-hand shunt increases the amount of current required to close the right-hand contact, or decreases the amount of current required to close the left-hand contact (with the proper direction of current flow). Also, if a relay trips to the right at the proper current, the dropout current can be raised by turning in the right-hand shunt. The two shunt-screw adjustments are not independent, however, and a certain amount of trimming adjustment of both shunt screws is generally necessary to obtain the desired pickup and dropout calibration.

In general, the farther out the two shunt screws are turned, the greater the toggle action will be, and as a result, the lower the dropout current. For the tripping units (3) of the PM-3, PM-13, and PM-23 relays, toggle action is desirable, with a dropout current around 75 percent of the pickup current. For the monitoring alarm relay units, toggle action is not desired. Instead, the armature is adjusted to float between the pole faces at a given current (1 or 2

TYPE PM MONITORING RELAYS

The following chart indicates the units present in each relay.

FUNCTION AND UNIT	PMA PMD	PMA-1 PMD-1	PM2	PM3	PM4	PM5	PM13	PMG13	PM23
Alarm for p.w. open, short or reversal (1) (2)	X	X	X				X	X	X
Transfer - Trip Unit (3)				X			X	X	X
Alarm for p.w. ground (5)	X					X		X	
D.C. Path for Monitoring Current					X				

ma.), and to move gradually toward the high or low-current alarm as the coil current is increased or or decreased. Similarly, the floating adjustment of the armature of the ground alarm unit (5) requires that both shunt screws be turned in relatively far. Then the armature will move gradually to the left or right as the current through the two #5 coils is unbalanced.

The electrical calibration of the polar unit is also affected by the contact adjustment as this changes the position of the polar unit armature. Do not change the contact adjustment without rechecking the electrical calibration.

Contact Adjustment - All Relays

For all monitoring alarm units, designated (1) or (2), turn in all the stationary contact and contact stop screws until they just touch the moving contact. Advance the screws to hold the armature in the central portion of the magnetic air gap between the two pole faces. (The stationary contact screws have a round silver contact face; the stop screws do not have this silver facing.) Now back off all the contact and contact stop screws one full turn. This will give a total contact travel of 0.050 inch. When the relay is properly calibrated, some touch-up adjustment may be necessary so that double contacts will both close at the same current value. The contact gap between the floating moving contact and the right-hand or left-hand stationary contacts or contact stops will be approximately 0.025 inch when the relay is in operation.

For the tripping (3) units of the PM-3, PM-13, PMG-13, and PM-23 relays, adjust the contacts as described in the previous paragraph, except back off the contact and stop screws one-half turn each to

give a total moving contact travel of approximately 0.025 inch. In operation of the tripping unit, the moving contact will normally rest against the contact stop screws, and will pick up only for a transferred-tripping operation.

For the pilot-wire ground alarm unit (5) of the PMA, PMD, PM5, and PMG-13 relays, follow the same general procedure except back off both stationary contact screws two turns each. This will give a contact gap of 0.050 on each side of the moving contact when it is its normal central position.

Electrical Calibration - All Relays

In the following sections, the calibration instructions are given for the polar unit which performs a certain function, such as alarm (1) or (2), ground (5), or trip (3), rather than giving calibration instructions for each complete relay. In this way, considerable duplication of instructions has been eliminated.

Alarm Unit (1)

Connect the relay as described under Acceptance Tests for the particular relay involved. Screw the two magnetic shunts all the way in, then back them out five turns each. With the relay energized at rated voltage, set the monitoring current at 1.3 or 2.3 ma. d.c. for 2 or 3-terminal relay respectively, by adjusting the external resistor. If the relay does not close its right-hand contact, turn in the left shunt screw until the right-hand contact just closes. If the right-hand contact is closed at 1.3 ma., turn in the right shunt until a point is reached when the right-hand contact is just closed at 1.3 ma.

Now drop the current to 0.7 ma. and adjust the opposite shunt until the left-hand contact just closes

TYPE PM MONITORING RELAYS

at 0.7 ma. d.c. At 1.0 ma. d.c., the moving contact should float half way between the two sets of stationary contacts with a 0.025-inch gap on each side. Recheck the high and low current calibration several times, touching up the shunt adjustments as required to obtain the desired calibration.

Polarization Check

For all the source relays, which are listed below, make the following additional calibration check:

- PMA PM-13 (a.c. and d.c.)
- PMA-1 PMG-13 (a.c. and d.c.)
- PMD
- PMD-1

After calibration as described in the previous sections, connect a 20,000 ohm resistor (or 10,000 ohms for 3-terminal applications) across the output terminals, and energize the relay at its rated supply voltage. With these connections, approximately one (or two) milliamperes d.c. will flow through the monitor relay coils and external resistor, thus representing normal operating conditions.

Now momentarily (one second or so) apply 48 volts d.c. directly to the pilot-wire terminals of the relay, as indicated in the following table.

Relay	<u>Terminals for Momentary Application of 48 V. d.c.</u>	
	<u>POS.</u>	<u>NEG.</u>
PMA, PMA-1 } PMD, PMD-1 }	6	7
PM-13 (a.c. or d.c.) } PMG-13 (a.c. or d.c.) }	8	9

After momentary application of the transfer-trip voltage as just explained, recheck the calibration of the monitoring alarm unit (1). If it has changed, make necessary trimming adjustments of the shunt screws until there is no change in calibrating of the alarm unit (1) after the transfer-trip voltage has been applied. The purpose of this test is to compensate for the small residual magnetism in the relay unit. The ground alarm unit (5) will not be affected by this test as the ampere-turns of the two windings cancel each other.

Alarm Unit (2)

For the alarm unit of the PM-2 or PM-23 relays, adjust the shunts so that the relay moving contact

floats at one ma. d.c., and closes the left-hand contact at 0.7 ma. d.c. The moving contact should float midway between the contact and contact stop at 1.0 ma. d.c. There is no high-current calibration for this relay unit.

Now apply 48 volts d.c. momentarily (one second or so) across the alarm unit coil-circuit terminals in a direction to operate the alarm relay. Then recheck the alarm unit calibration. If there is any change, touch up the shunt adjustments until there is no change in calibration after 48 v. d.c. has been applied.

Tripping Unit (3)

To calibrate the tripping unit of the PM-3, PM-13, PMG-13, or PM-23 relays apply a d.c. voltage as explained below, to the following relay terminals:

Relays	D.C.	Voltage
	Pos.	Neg.
PM-3	9	8
PM-13 (a.c. or d.c.)	16	20
PMG-13 (a.c. or d.c.)	8	9
PM-23	8	9

Momentarily (one second or so) apply 48 volts d.c. to the terminals shown in the chart. Then starting with both shunts all the way in, turn out the right-hand shunt screw until the relay closes its right-hand trip contact at 14 volts d.c. (This will give approximately 2 ma. through the relay coil.) Now draw out the left-hand shunt until the relay resets with toggle action (not gradually) at not less than 10 volts d.c. When the calibration is approximately correct, again apply 48 volts d.c. to the indicated terminals, then recheck the pickup and dropout voltage, making any necessary trimming adjustments of the shunts. When the relay is properly adjusted, the application of 48 volts.d.c. will not change the pickup or dropout voltage points. The relay should trip and reset with toggle action in this application. This will require both shunt screws to be withdrawn farther than for floating action.

Ground Alarm Unit (5)

For the PM-5 relay, turn both shunt screws all the way in, then back them out five turns each. Pass a current of 0.3 ma. d.c. in terminal 6 and out terminal 7. Following the same general procedure as described previously in the section entitled "Alarm Unit (1)," adjust the shunt screws so that the left-hand contact closes at 0.3 ma. Now pass 0.3 ma. d.c.

TYPE PM MONITORING RELAYS

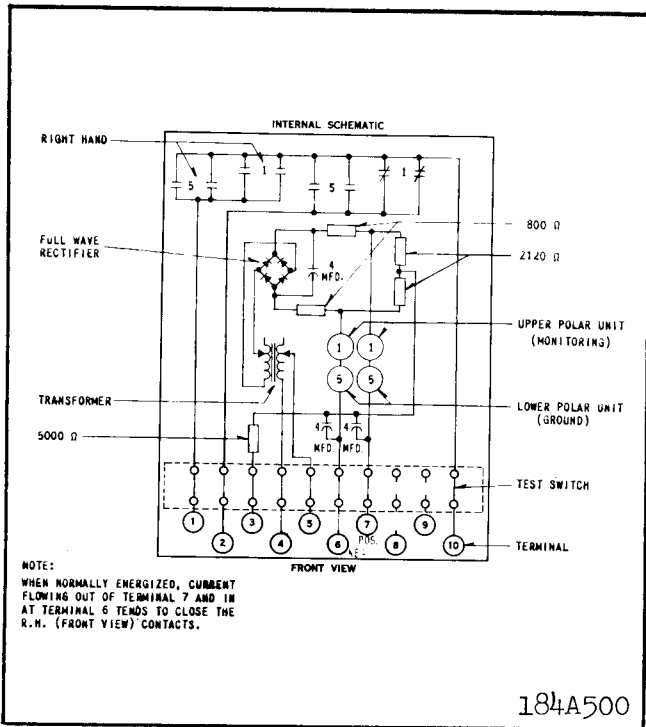

Fig. 2. Internal schematic of the type PMA relay in FT 31 case - 120 volt, 60 cycle supply - For two terminal lines.

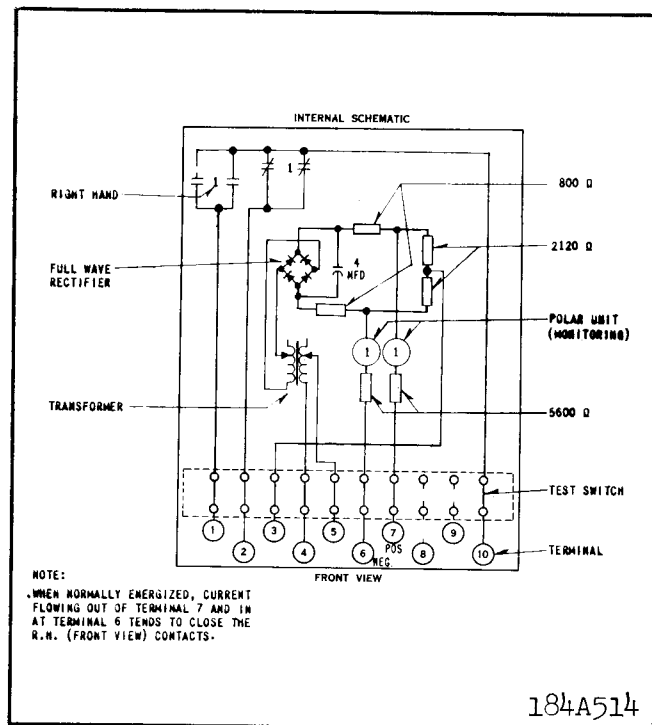

Fig. 3. Internal schematic of type PMA-1 relay in the FT 21 case - 120 volts, 60 cycle supply - For two terminal lines.

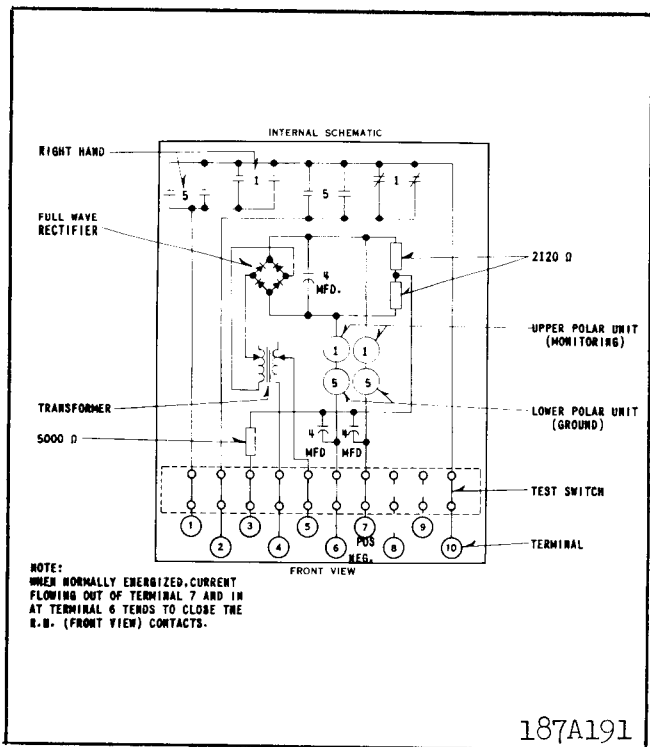

Fig. 4. Internal schematic of type PMA relay in FT 31 case - 120 volt, 60 cycle supply - For three terminal lines.

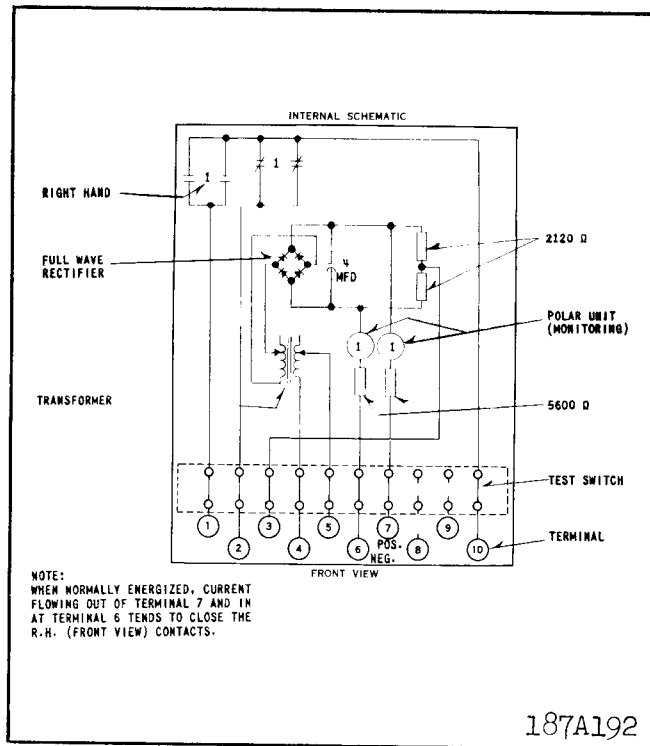

Fig. 5. Internal schematic of type PMA-1 relay in FT 21 case - 120 volt, 60 cycle supply - For three terminal lines.

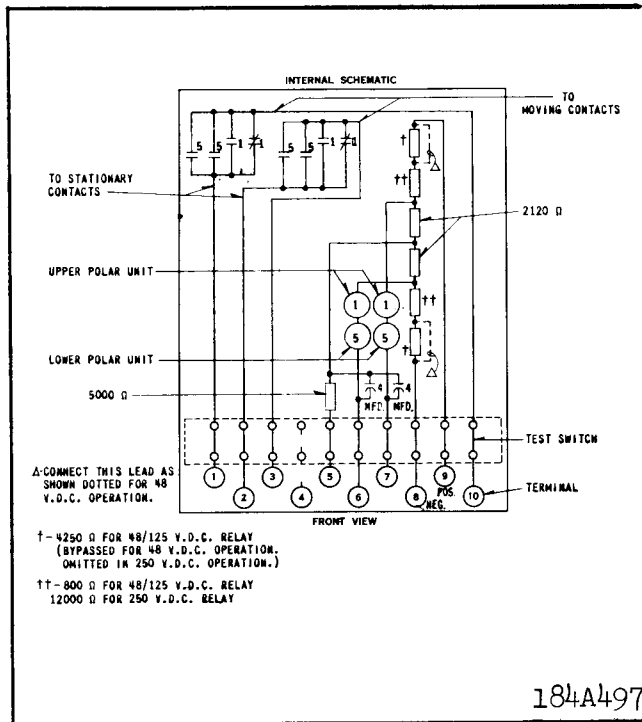

Fig. 6. Internal schematic of the type PMD relay in FT 21 case - DC supply - for two terminal lines.

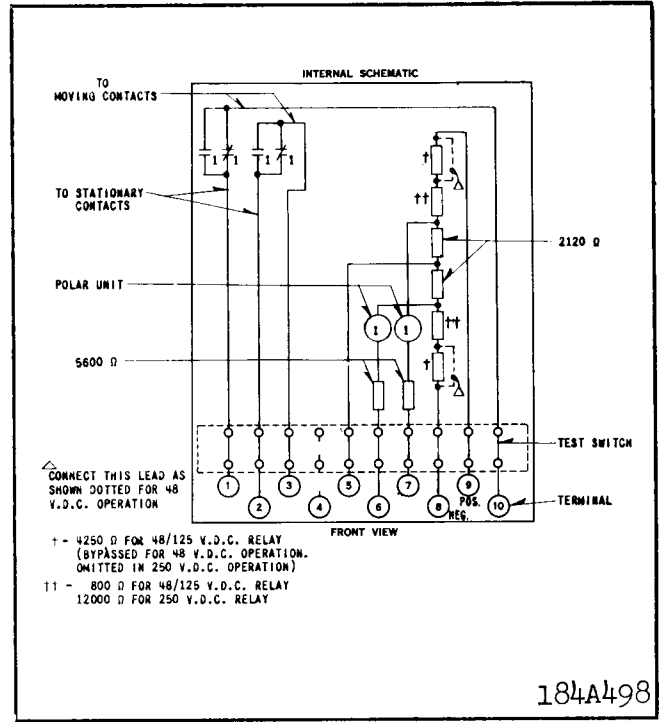

Fig. 7. Internal schematic of the type PMD-1 relay in the FT 11 case - DC supply - For two terminal lines.

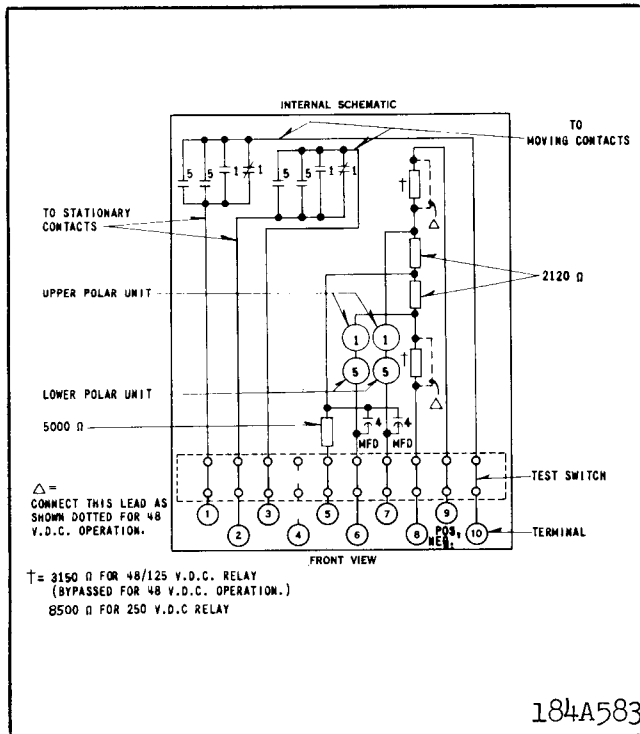

Fig. 8. Internal schematic of the type PMD relay in the FT 21 case - DC supply - For three terminal lines.

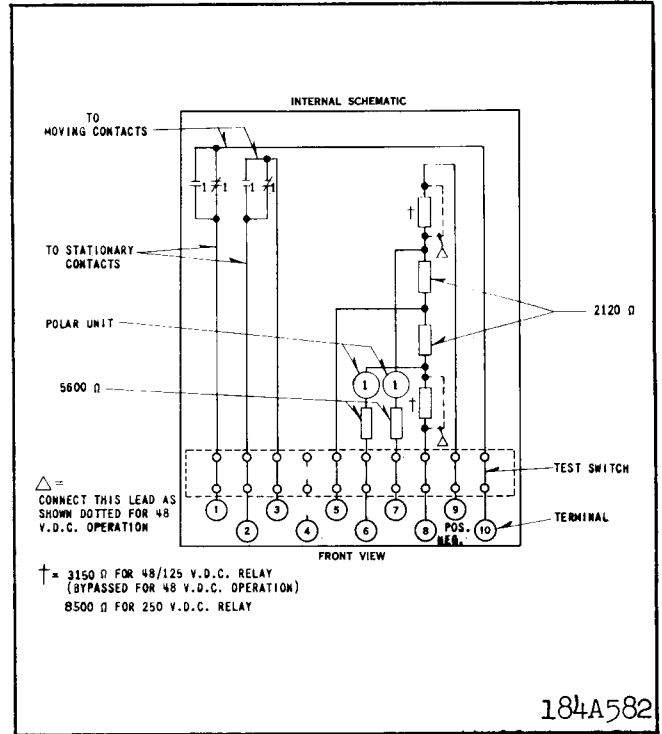

Fig. 9. Internal schematic of the type PMD-1 relay in the FT 11 case - DC supply - For three terminal lines.

TYPE PM MONITORING RELAYS

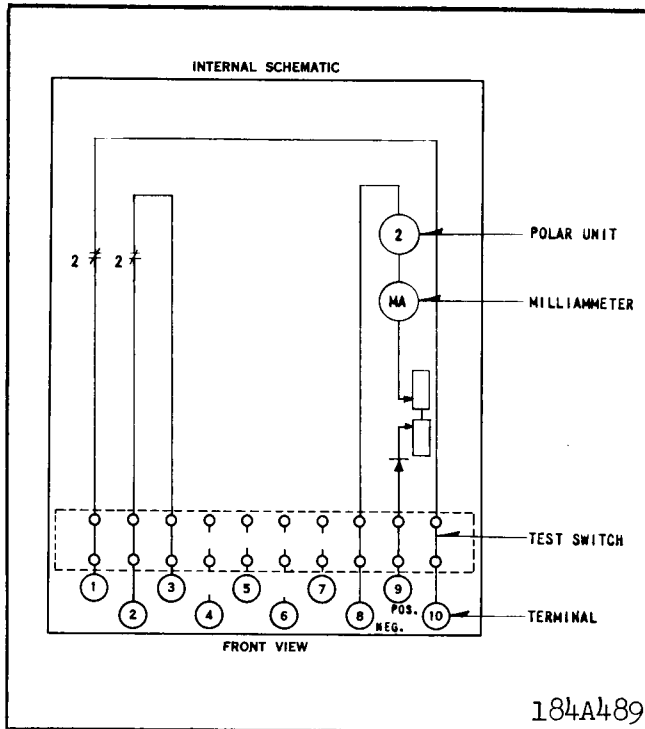

Fig. 10. Internal schematic of the type PM-2 relay in the FT 21 case.

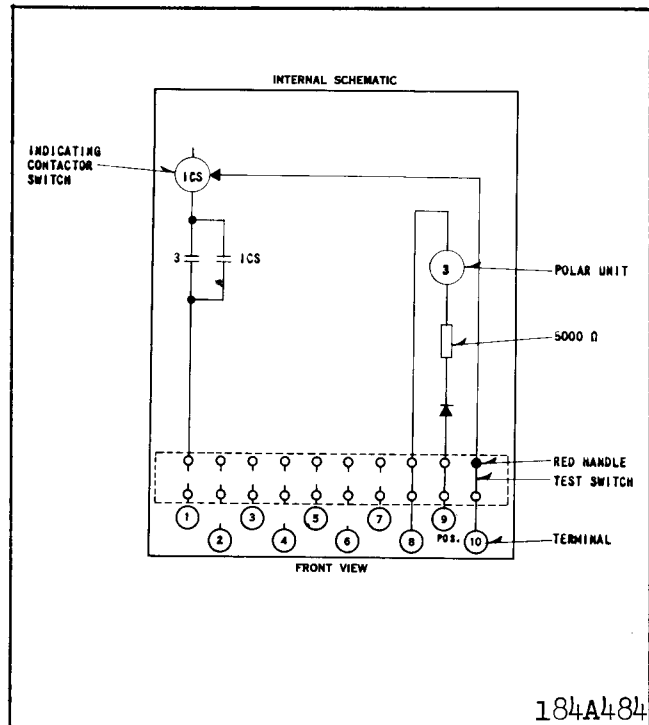

Fig. 11. Internal schematic of the type PM-3 relay in the FT 11 case.

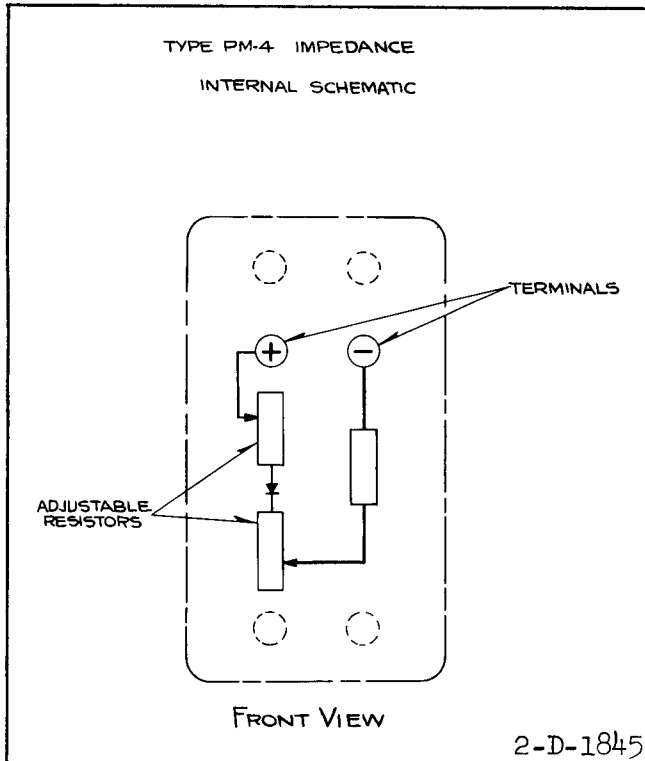

Fig. 12. Internal schematic of the type PM-4 Auxiliary Unit in the small molded case.

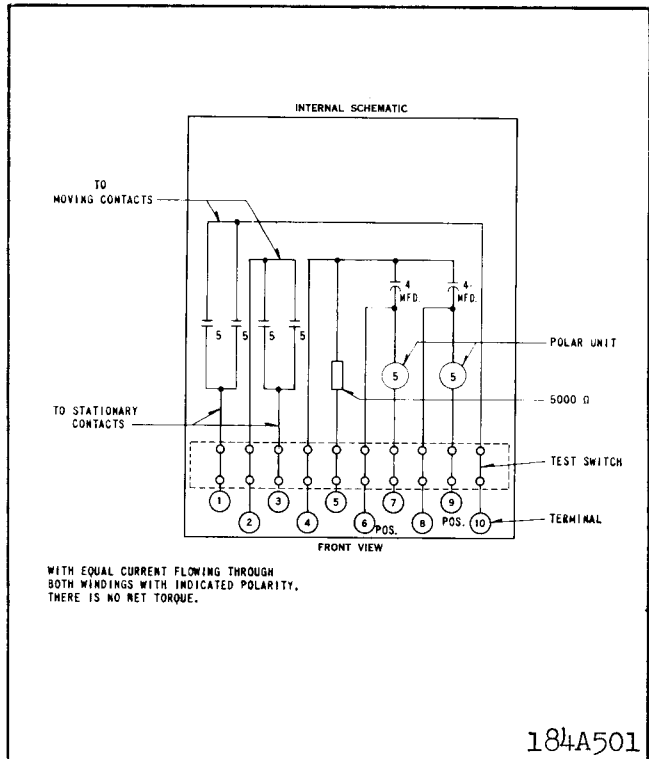

Fig. 13. Internal schematic of the type PM-5 ground detector relay in the FT 11 case.

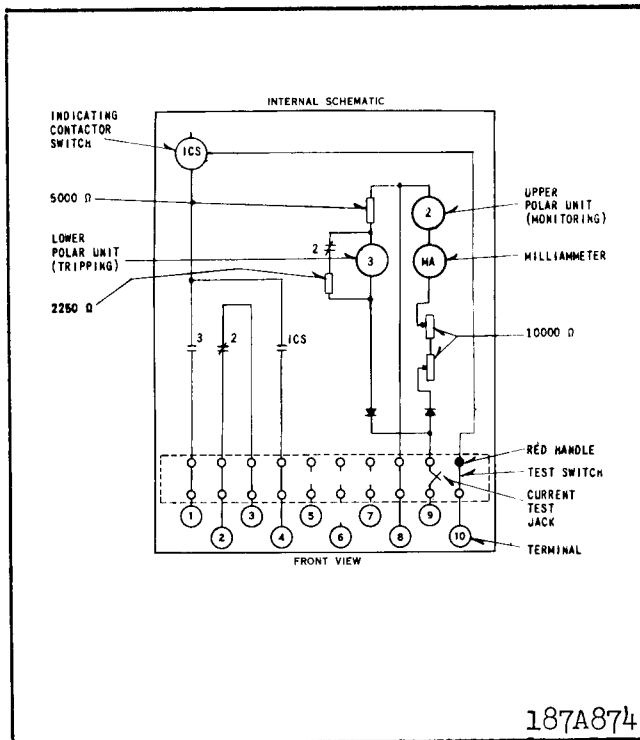

Fig. 14. Internal schematic of the type PM-23 relay in the FT 21 case.

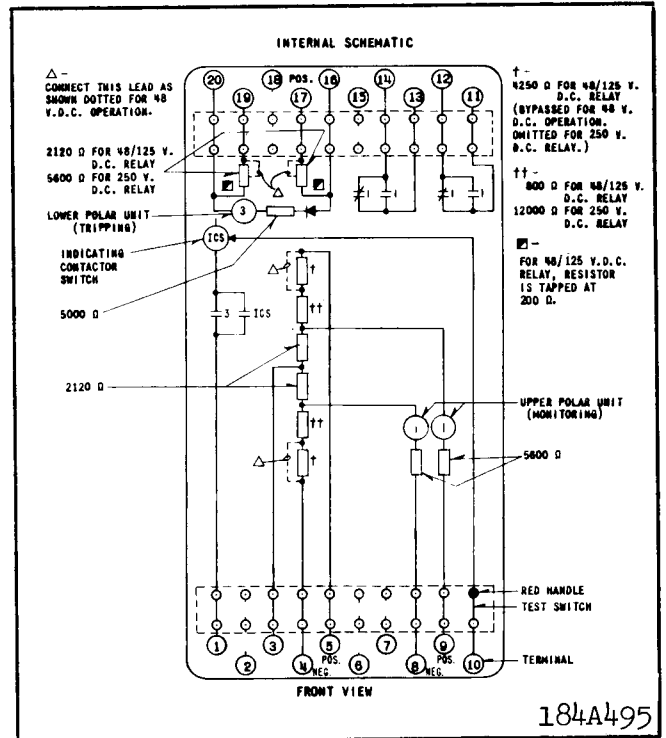

Fig. 15. Internal schematic of the type PM-13 relay in the FT 32 case - DC supply - For two terminal lines.

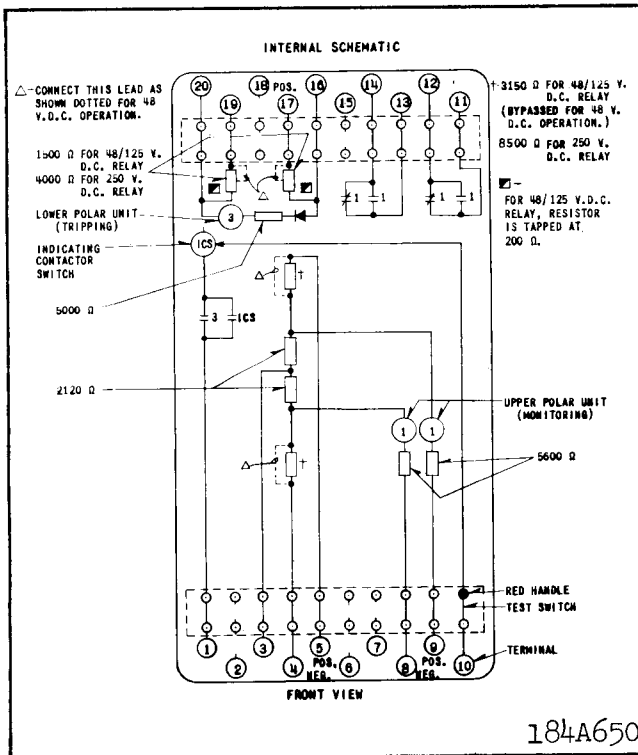

Fig. 16. Internal schematic of the type PM-13 relay in the FT 32 case - DC supply - For three terminal lines.

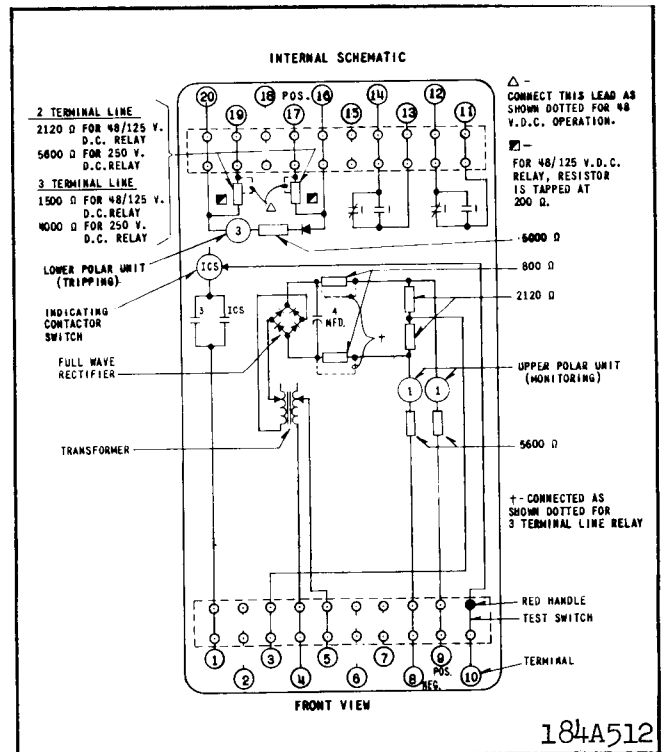

Fig. 17. Internal schematic of the type PM-13 relay in the FT 32 case - 120 volt, 60 cycle supply - For two or three terminal lines.

TYPE PM MONITORING RELAYS

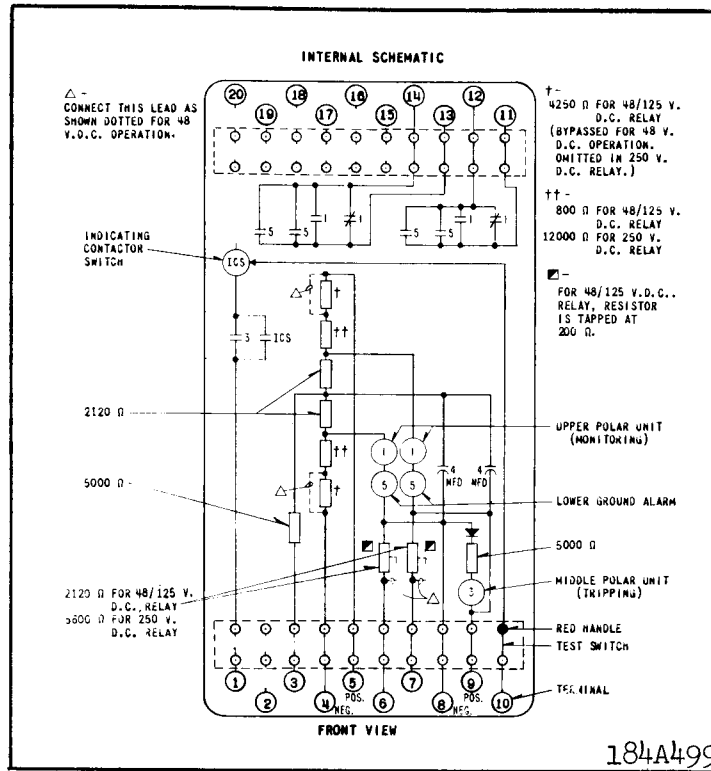

Fig. 18. Internal schematic of the type PMG-13 relay in the FT 32 case - DC supply - For two terminal lines.

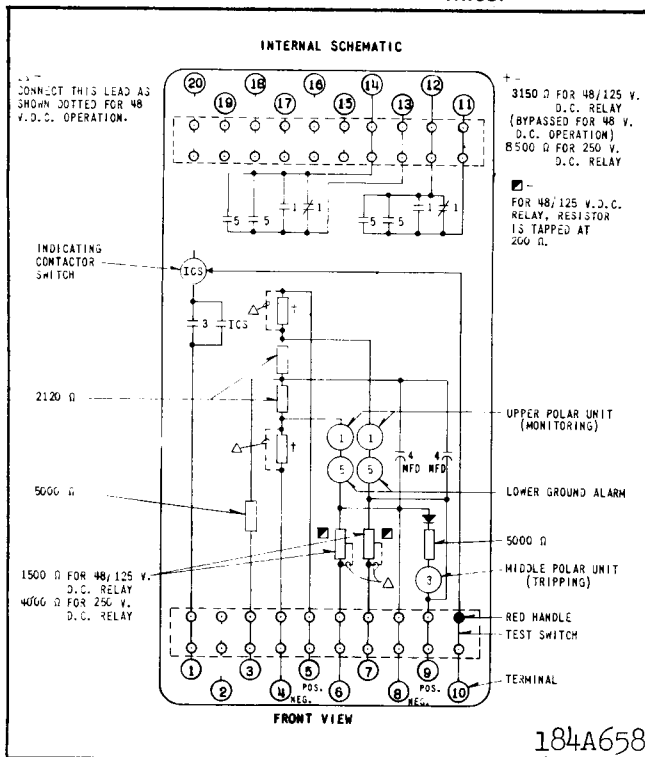

Fig. 19. Internal schematic of the type PMG-13 relay in the FT 32 case - DC supply - For three terminal lines.

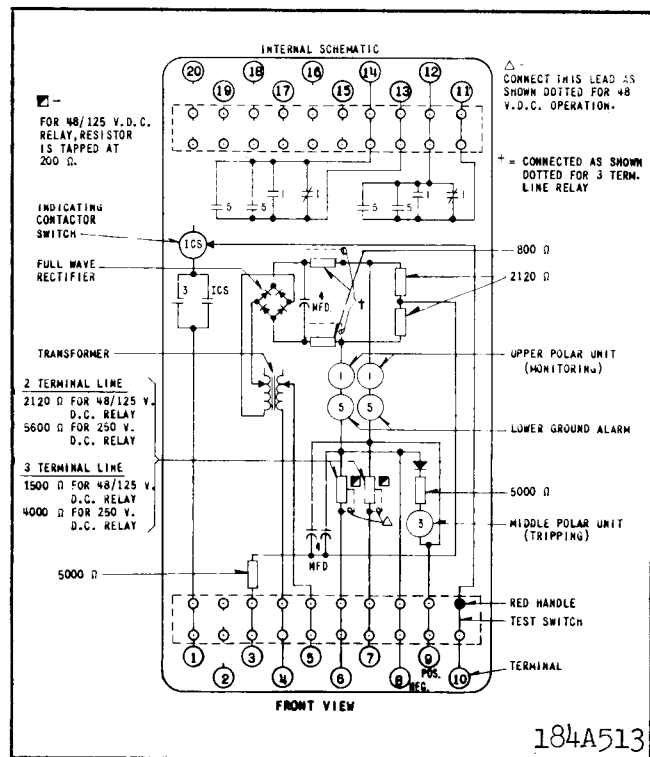

Fig. 20. Internal schematic of the type PMG-13 relay in the FT 32 case - 120 volt, 60 cycle supply - For two or three terminal lines.

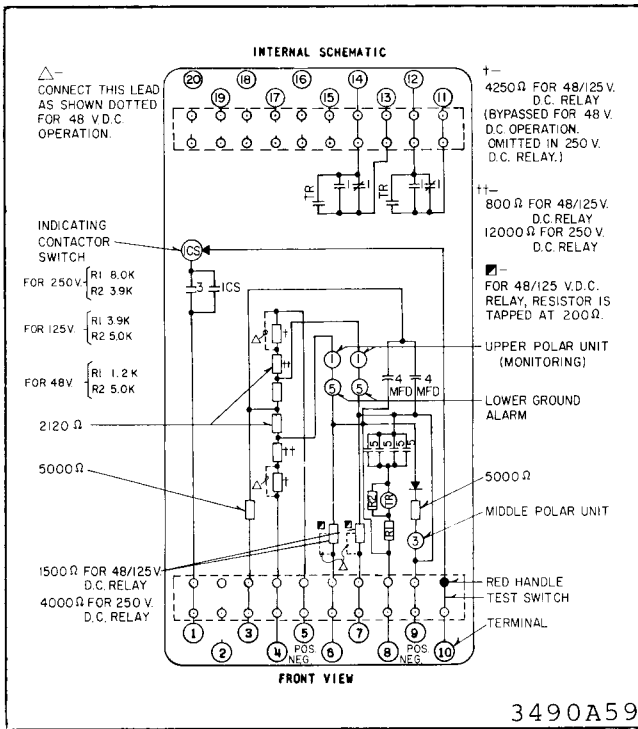

Fig. 21. PMG-13 Relay with Ground Alarm and Remote Trip - Two Terminal Lines with Telephone Relay Output - FT-32 Case.

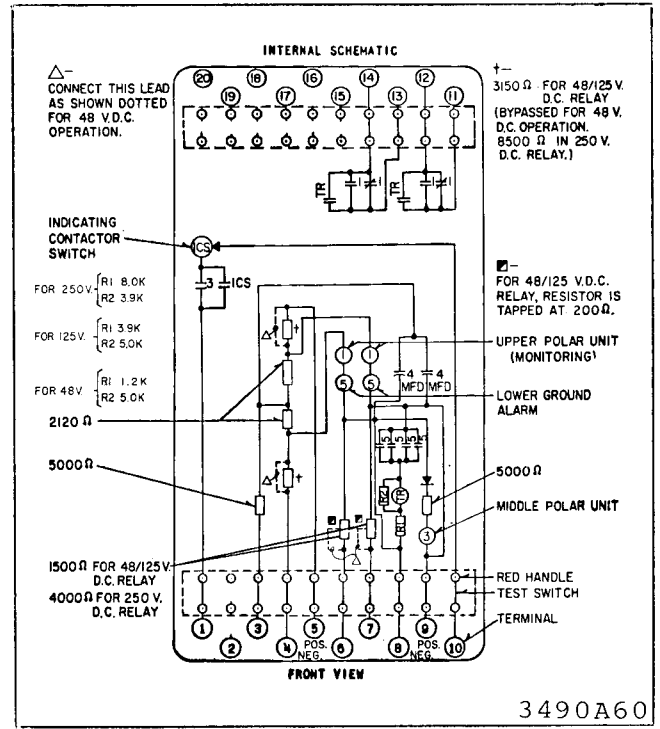

Fig. 22. PMG-13 Relay with Ground Alarm and Remote Trip - Three Terminal Lines with Telephone Relay Output - FT-32 Case.

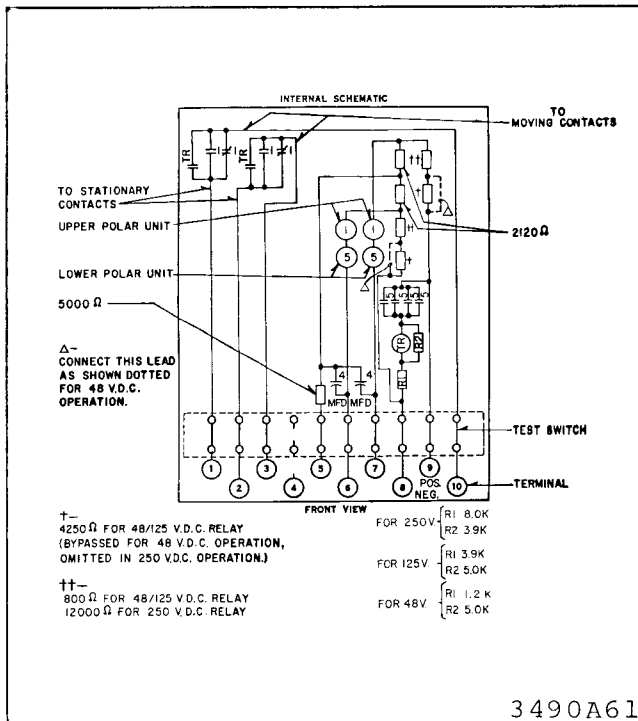

Fig. 23. PMD Relay - Ground Alarm, D.P.D.T. Contacts, Two Terminal Lines with Telephone Relay Output - FT-21 Case.

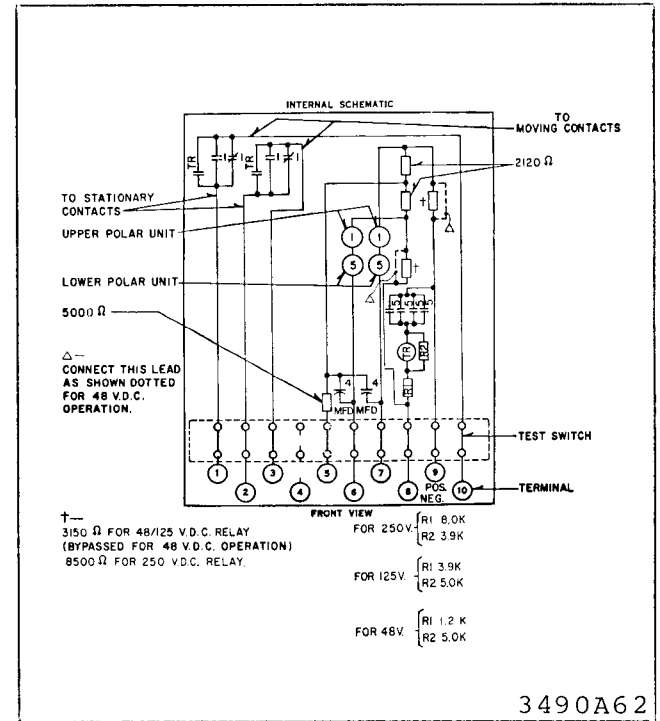

Fig. 24. PMD Relay - Ground Alarm, D.P.D.T. Contacts, Three Terminal Lines with Telephone Relay Output - FT-21 Case.

TYPE PM MONITORING RELAYS

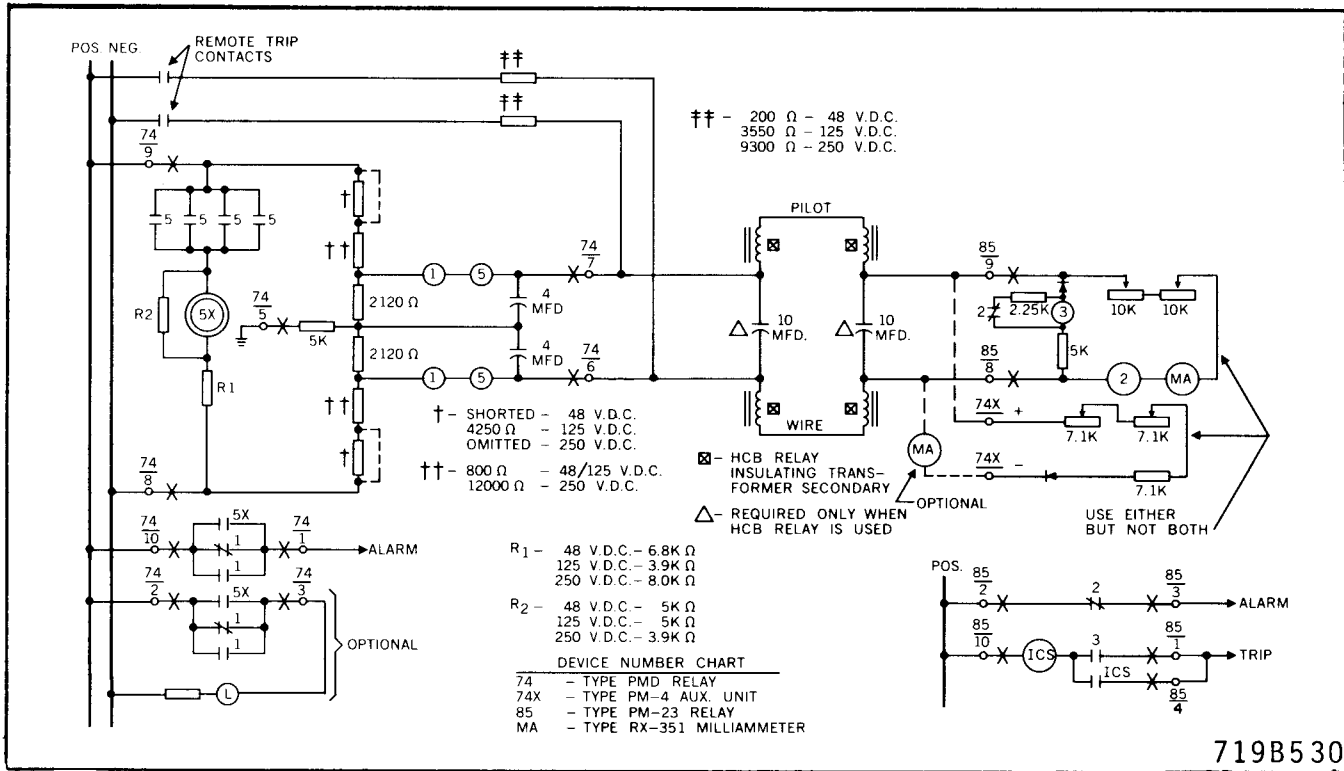

Fig. 25. External schematic of the type PMD relay with type PM-23 or PM-4 relay - Two terminal lines.

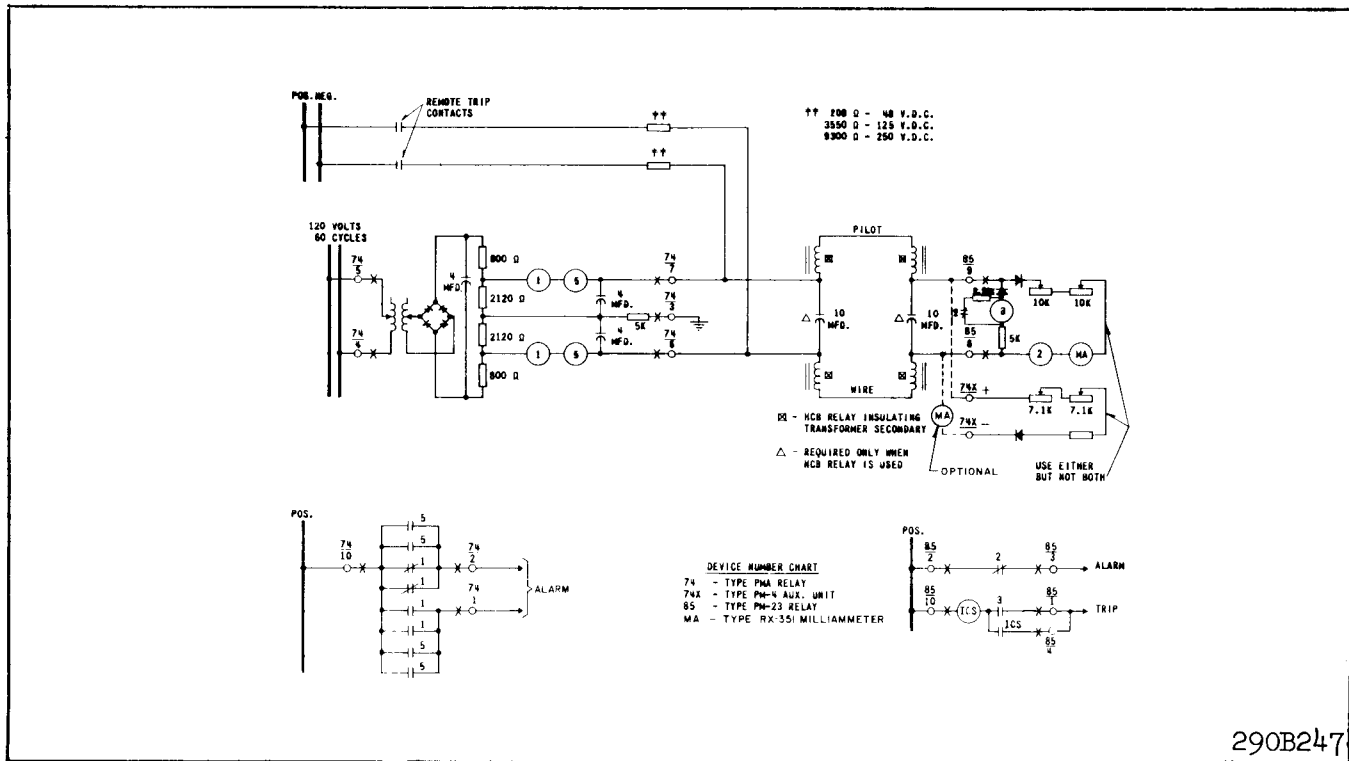

Fig. 26. External schematic of the type PMA relay with type PM-23 or PM-4 relay - Two terminal lines.

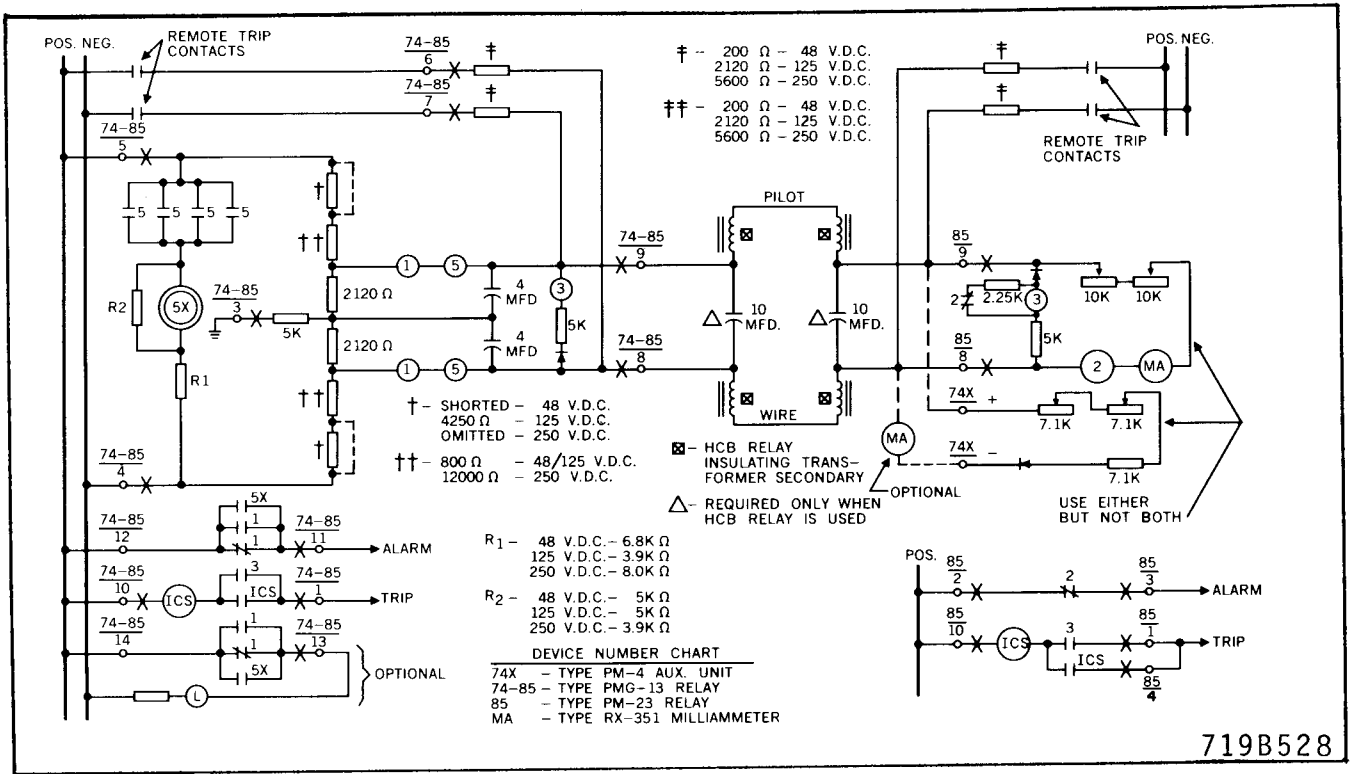

Fig. 27. External schematic of the DC type PMG-13 relay with type PM-23 or PM-4 relay - Two terminal lines.

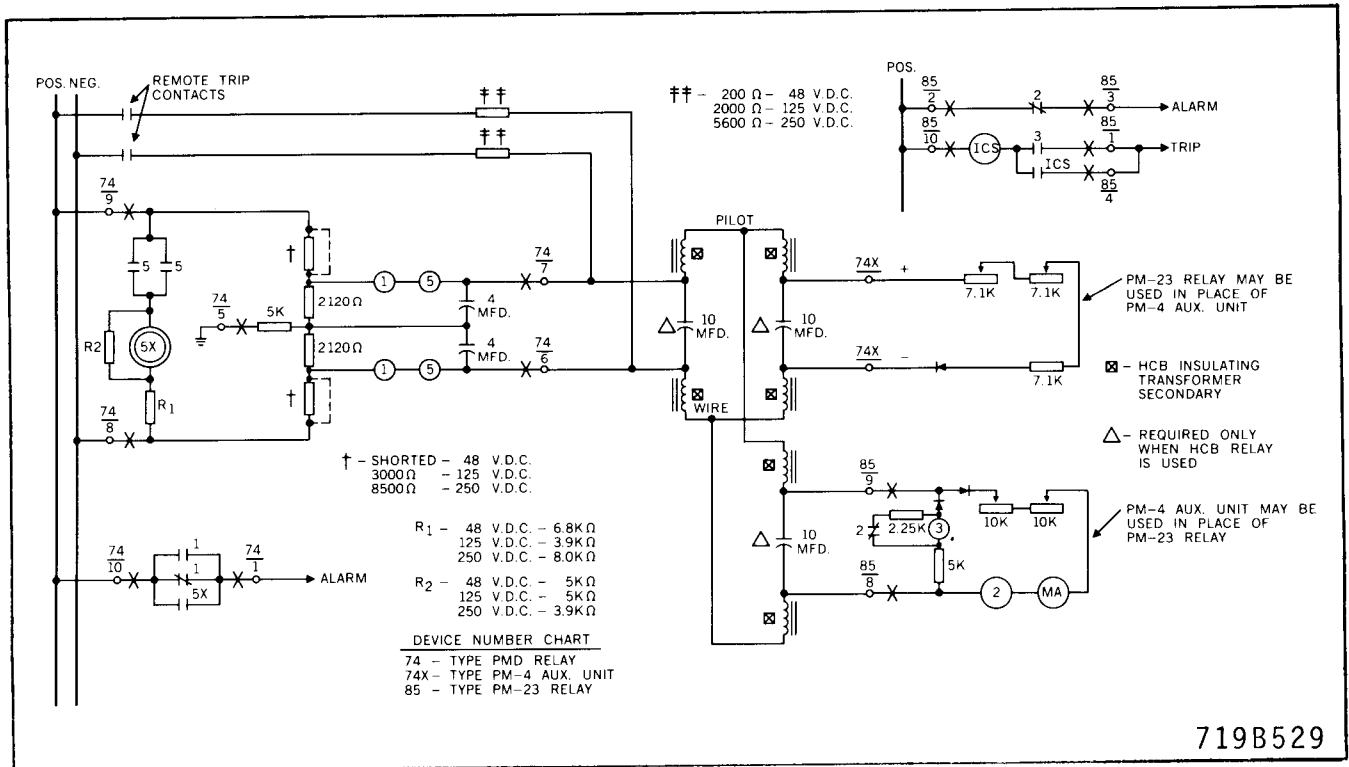

Fig. 28. External schematic of the type PMD relay with type PM-23 and PM-4 relays - Three terminal lines.

TYPE PM MONITORING RELAYS

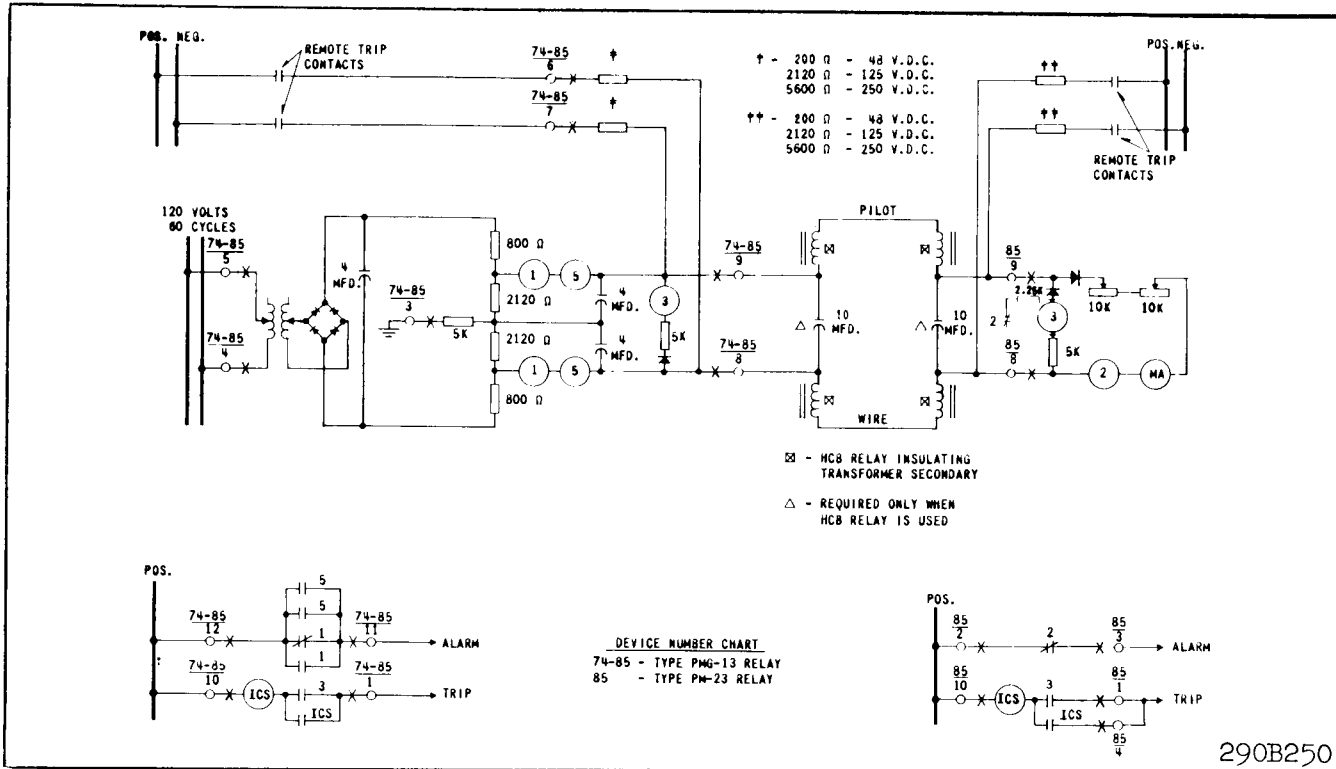

Fig. 29. External schematic of the AC type PMG-13 with type PM-23 relay - Two terminal lines.

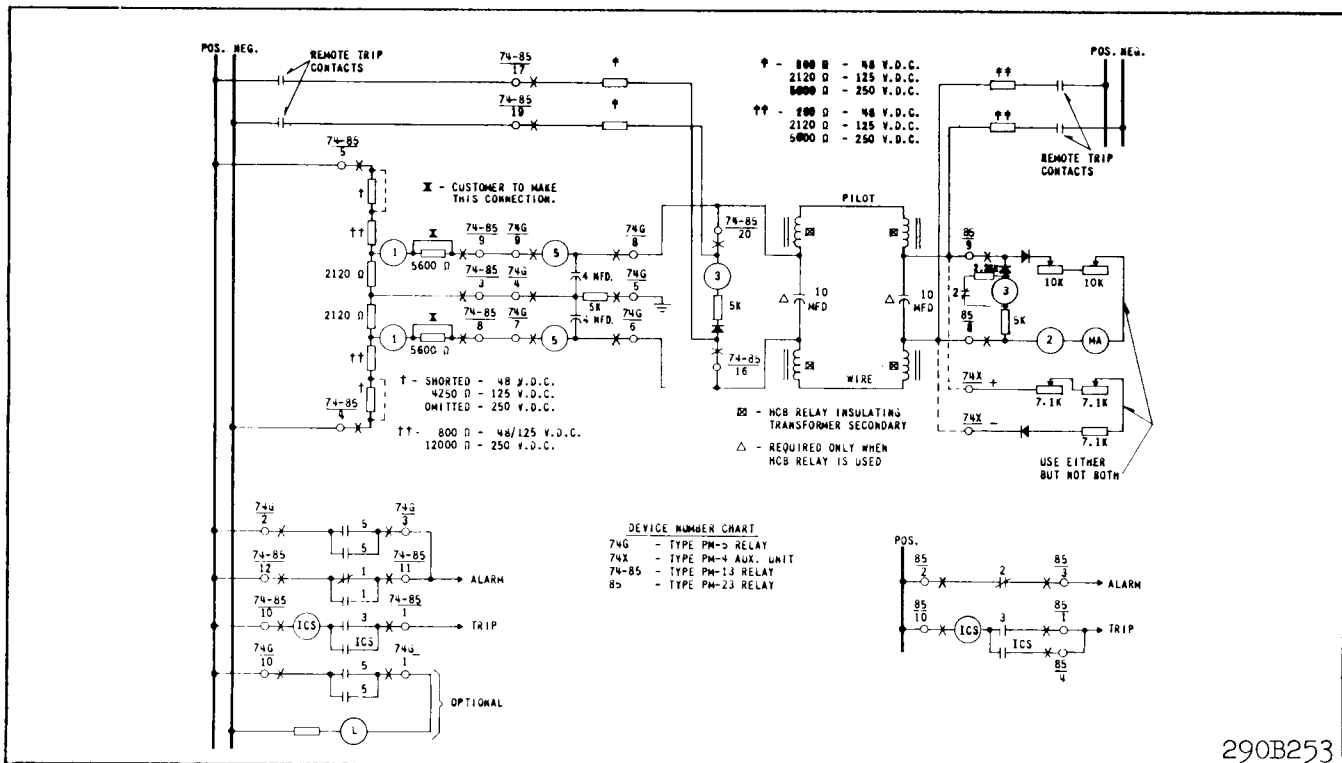

Fig. 30. External schematic of the DC type PM-13 and PM-5 relay with type PM-23 or PM-4 relay - Two terminal lines.

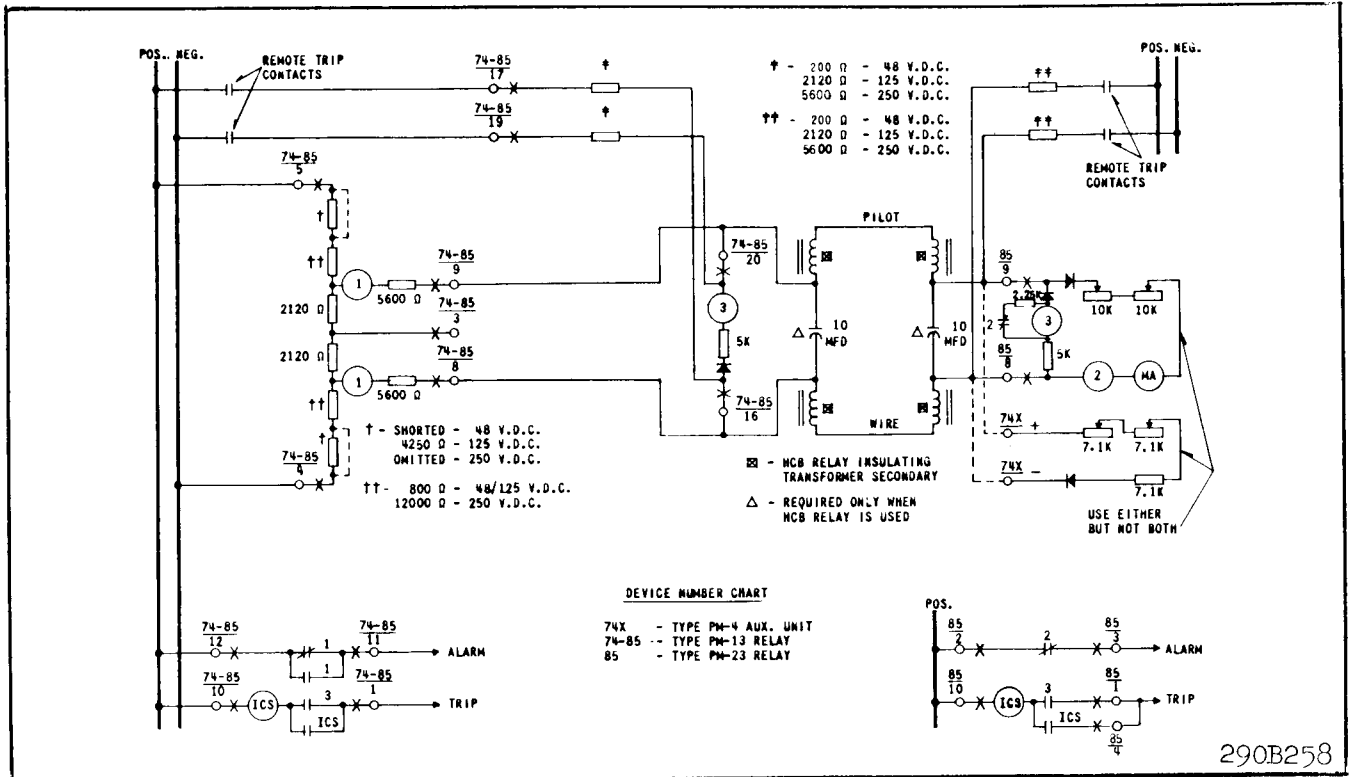

Fig. 31. External schematic of the DC type PM-13 relay with type PM-23 or PM-4 relay - Two terminal lines.

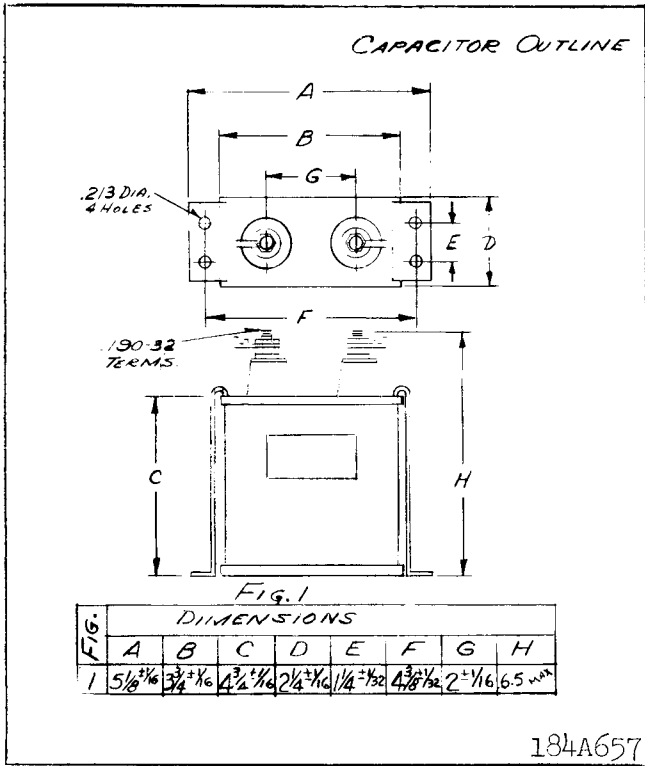

Fig. 32. Outline and Drilling Plan for 10 mfd. capacitor – For reference only.

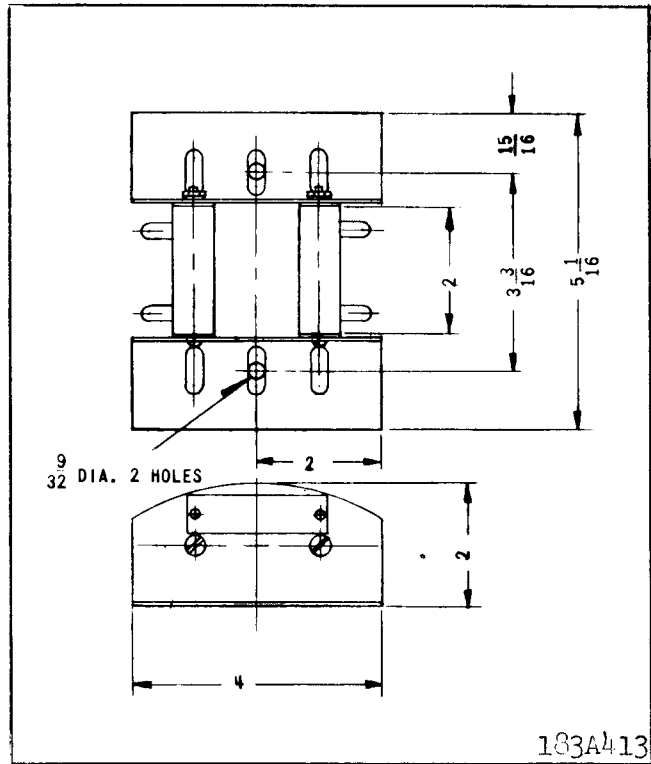

Fig. 33. Outline and Drilling Plan for External Remote trip Resistor Assembly.

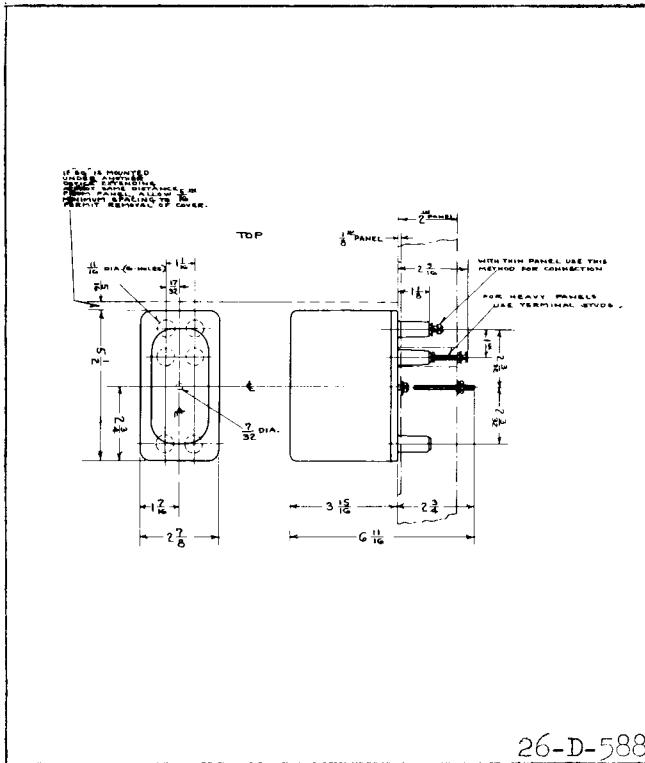

Fig. 34. Outline and Drilling Plan for the type PM-4 Auxiliary unit in the projection molded case.

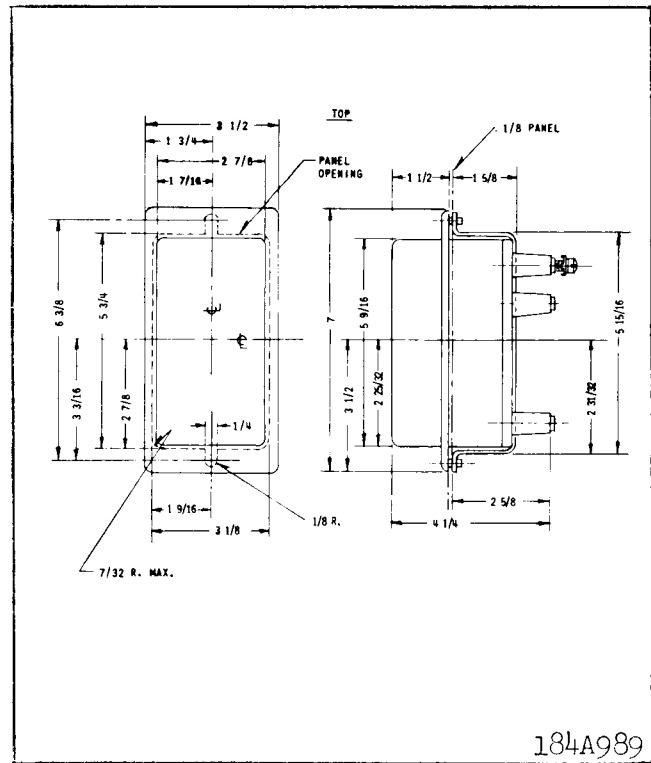

Fig. 35. Outline and Drilling Plan for the type PM-4 Auxiliary unit in the Semi-Flush molded case.

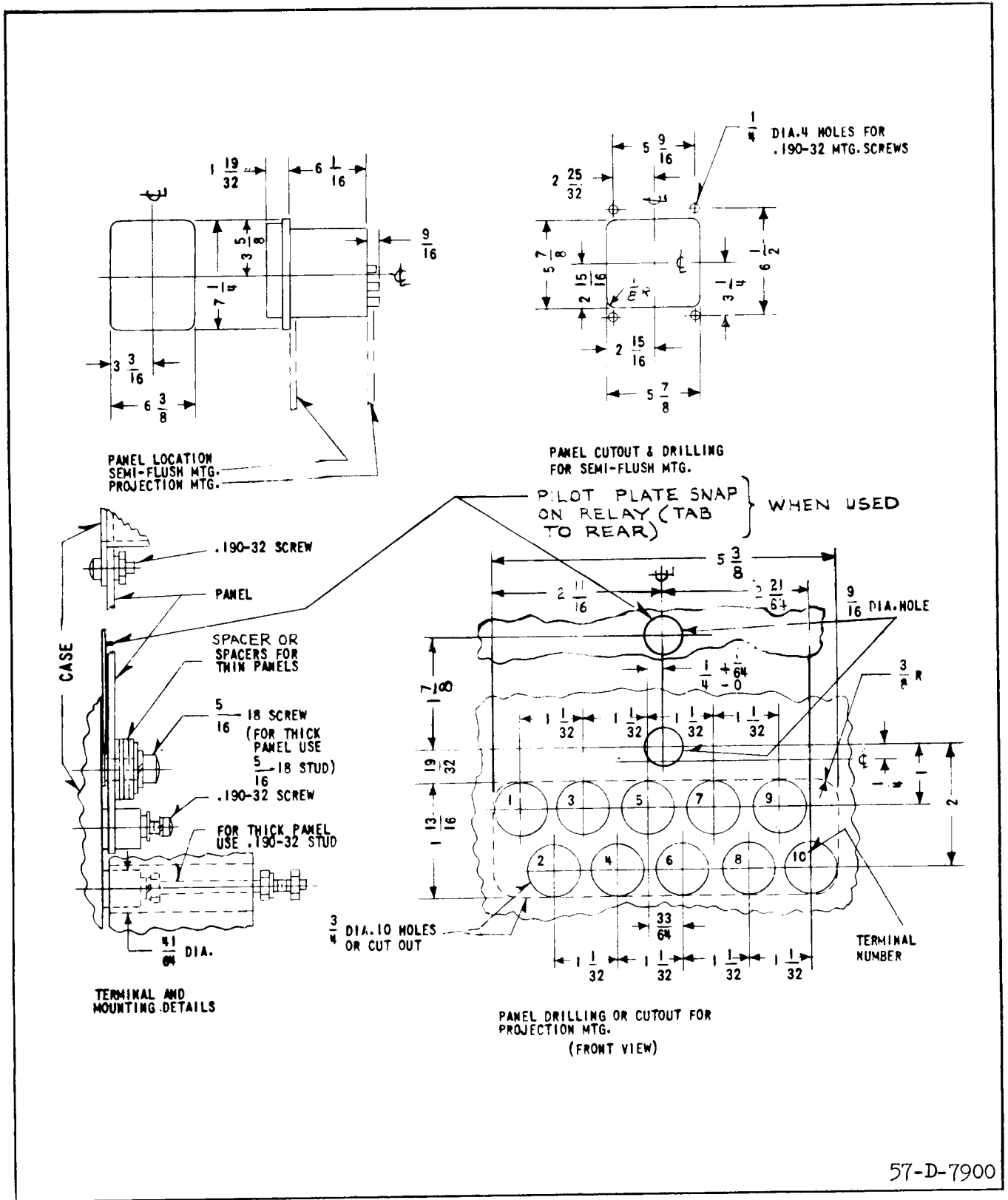
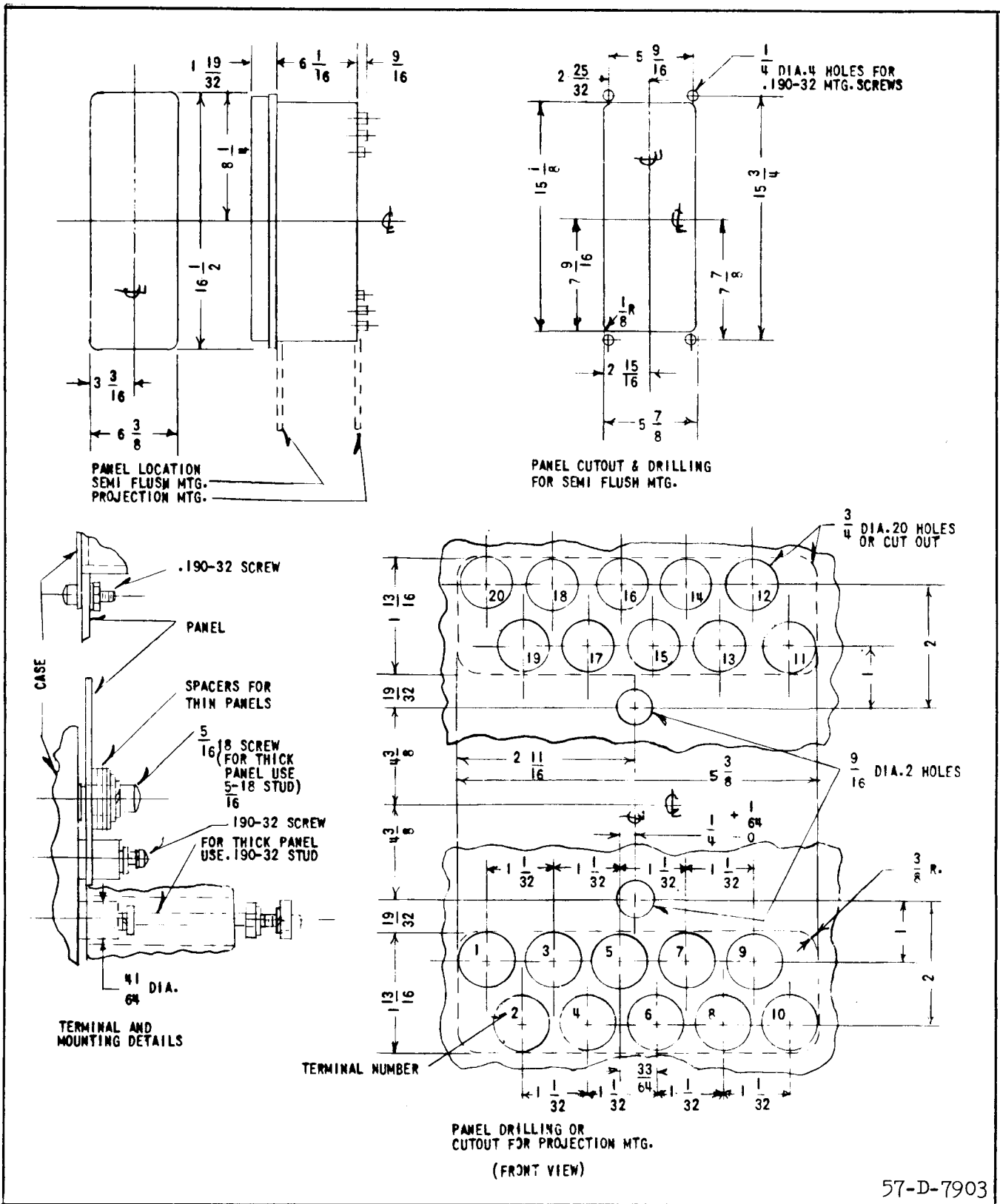

Fig. 36. Outline and Drilling Plan for the type PM-3, PM-5, & PMD-1 Relays in the type FT 11 case.

TYPE PM MONITORING RELAYS



57-D-7903

Fig. 39. Outline and Drilling Plan for the type PM-13 and PMG-13 relays in the type FT 32 case.

WESTINGHOUSE ELECTRIC CORPORATION
RELAY-INSTRUMENT DIVISION

NEWARK, N. J.

Printed in U.S.A.

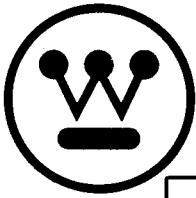

INSTALLATION • OPERATION • MAINTENANCE INSTRUCTIONS

TYPE PM LINE OF RELAYS FOR PILOT-WIRE MONITORING AND TRANSFERRED TRIPPING

CAUTION Before putting protective relays into service, remove all blocking which may have been inserted for the purpose of securing parts during shipment, make sure that all moving parts operate freely, inspect the contacts to see that they are clean and close properly, and operate the relay to check the settings and electrical connections.

APPLICATION

Type PM Monitoring Relays provide continuous monitoring of a pilot-wire circuit to detect open circuits, short circuits, grounds, and wire reversal. In addition, transferred tripping can be effected where the PM-3, PM-13, PMG-13 or PM-23 relays are used. Table I illustrates the functions available with each relay. A 10 mfd. capacitor is supplied with each PM relay. This capacitor provides an a-c path between the two halves of the insulating transformer secondary windings as shown in Figs. 21 through 27.

Each circuit requires the following:

At one end to introduce monitoring current

One of the following:

For a-c Supply

For d-c Supply

PMA

PMD

PMA-1

PMD-1

PM-13 or PMG-13 (a.c.)

PM-13 or PMG-13 (d.c.)

At the other end to receive monitoring current (two-terminal line)

One PM-23 or PM-2 or PM-4

At the other ends to receive monitoring current (three-terminal line)

Two PM-23 or two PM-4 or two PM-2 or any combination of two of these relays.

CONSTRUCTION

PM relays consist of the following:

PMA

PMA-1

1-Polar Alarm Unit (1)

1-Polar Alarm Unit

1-Polar Ground Unit (5)
1-Tapped Transformer
1-Full-Wave Rectifier
3-4 mfd. Capacitors
1-Set of Potential
Dividing Resistors

PMD

1-Polar Alarm Unit (1)
1-Polar Ground Unit (5)
2-4 mfd. Capacitors
1-Set of Potential
Divider Resistors

PMG-13

1-Polar Alarm Unit (1)
1-Polar Ground Unit (5)
1-Polar Trip Unit (3)
1-Indicating Contactor
Switch
1-Set of Potential
Divider Resistors
1-Tapped Transformer
(A.C. Relay only)
1-Full-Wave Rectifier
(A.C. Relay only)
1-Blocking Rectifier
2-Remote Trip Resistors
3-4 mfd. Capacitors
(A-C Relay)
2-4 mfd. Capacitors
(D-C Relay)

PM-23

1-Polar Alarm Unit (2)
1-Polar Trip Unit (3)
1-Indicating Contactor
Switch (ICS)
1-Milliammeter, 5.0 ma.
1-Set of Adjustable and
Fixed Resistors
2-Blocking Rectifiers

1-Tapped Transformer
1-Full-Wave Rectifier
1-4 mfd. Capacitor
1-Set of Potential
Dividing Resistors

PMD-1

1-Polar Alarm Unit
1-Set of Potential
Divider Resistors

PM-13

1-Polar Alarm Unit (1)
1-Polar Trip Unit (3)
1-Indicating Contactors
Switch
1-Set of Potential
Divider Resistors
1-Tapped Transformer
(A.C. Relay only)
1-Full-Wave Rectifier
(A.C. Relay only)
1-Blocking Rectifier
2-Remote Trip Resistor
1-4 mfd. Capacitor

PM-2

1-Polar Alarm Unit (2)
1-Milliammeter, 5.0 ma.
1-Set of Adjustable
Resistors
1-Blocking Rectifier

SUPERSEDES I.L. 41-973.5D

*Denotes change from superseded issue.

EFFECTIVE JUNE 1969

TYPE PM MONITORING RELAYS

PM-3

- 1-Polar Trip Unit (3)
- 1-Resistor
- 1-Blocking Rectifier
- 1-Indicating Contactor Switch (ICS)

PM-4

- 1-Blocking Rectifier
- 1-Set of Adjustable & Fixed Resistors

PM-5

- 1-Polar Ground Unit (5)
- 2-4 mfd. Capacitors
- 1-Fixed Resistor

TABLE I

FUNCTION	PMA & PMD	PMA-1 & PMD-1	PM-13	PMG-13	PM-23	PM-2	PM-3	PM-4	PM-5
Monitoring Current Source	X	X	X	X					
Receives Monitoring Current					X	X		X	
Trouble Alarm	X	X	X	X	X	X			X
Transmits Trip Signal	X †	X †	X	X	X †	X †	X †	X †	
Receives Trip Signal			X	X	X		X		
Sensitive Ground Detection	X			X					X
Measures Monitoring Current					X	X			

† With External Resistors

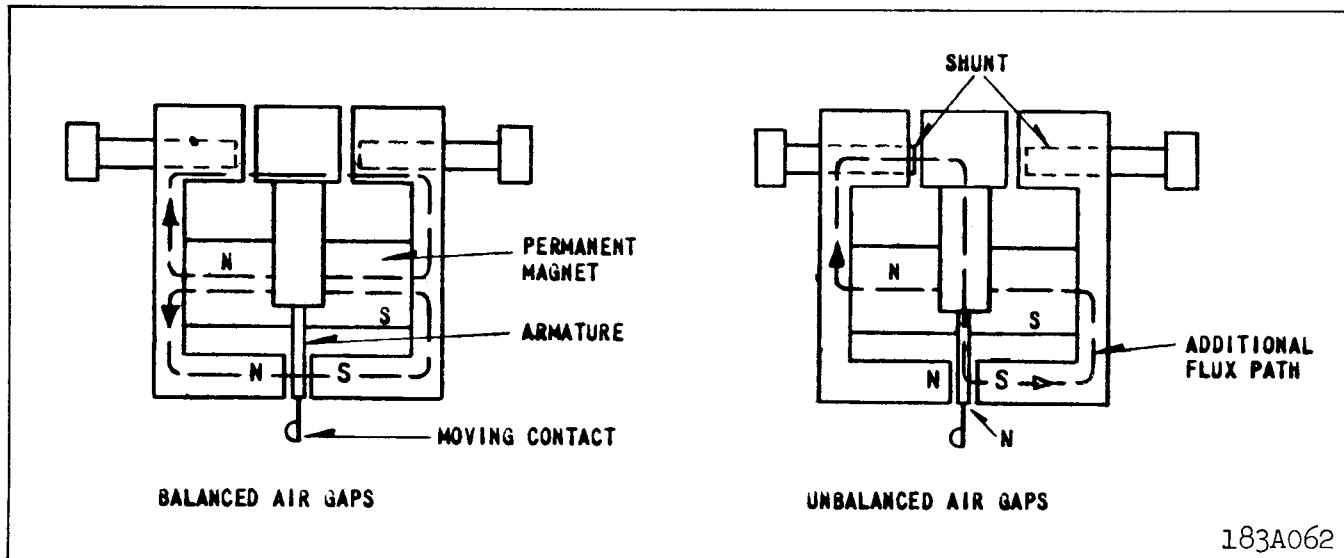

Fig. 1. Polar Unit Permanent Magnet Flux Paths.

183A062

Polar Unit

The polar unit consists of a rectangular shaped magnetic frame, an electromagnet, a permanent magnet, and an armature. The poles of the crescent shaped permanent magnet bridge the magnet frame. The magnetic frame consists of three pieces joined in the rear with two brass rods and silver solder. These non-magnetic joints represent air gaps, which are bridged by two adjustable magnetic shunts. The winding or windings are wound around a magnetic core. The armature is fastened to this core and is free to move in the front air gap. The moving contact is connected to the free end of a leaf spring, which, in turn, is fastened to the armature.

Indicating Contactor Switch

The d-c indicating contactor switch is a small clapper type device. A magnetic armature, to which leaf-spring mounted contacts are attached, is attracted to the magnetic core upon energization of the switch. When the switch closes, the moving contacts bridge two stationary contacts, completing the trip circuit. Also during this operation two fingers on the armature deflect a spring located on the front of the switch, which allows the operation indicator target to drop. The target is reset from the outside of the case by a push rod located at the bottom of the cover.

The front spring, in addition to holding the target, provides restraint for the armature and thus controls the pickup value of the switch.

OPERATION

Pilot Wire Monitoring

Monitoring current is introduced into the pilot wire as shown in the external schematics, figures 21 to 27, by the monitoring current source. External schematics showing other combinations are available on request. A nominal 20 volts is impressed across the 10 mfd. capacitor at the left-hand line terminal in Figures 21 to 27. This voltage produces a current circulating through one winding of the HCB insulating transformer, one pilot wire, the PM-23, PM-2, or PM-4, and back through the other pilot wire and the other winding of HCB insulating transformer.

Adjustment of the resistors of the PM-23, PM-2 or PM-4 relay at the other end of the pilot wire provides a normal one-milliamperere d-c circulating current. In the case of three-terminal lines, the monitoring source relay output current is 2 ma. in order to pro-

vide each receiving end relay with 1 ma. The alarm unit of the monitoring current source relay is adjusted to float between the high and low current contacts with normal monitoring current. The PM-23, receiving-end alarm relay, is adjusted to float between the low-current alarm contact and a contact stop with 1 ma. flowing.

Short Circuits

A complete or partial short circuit on the pilot wires increases the current in the current-source relay, causing the high-current alarm contacts to close. The resulting current decrease in the PM-23 relay closes the alarm contact. Short circuits of 5000 ohms or less will be detected.

Open Circuits

Current decreases to zero in all relays. Low-current alarm contact of the current source relay closes. Alarm contact of PM-23 relay closes.

Reversed Wires

On applications using the PM-23 relay, current increases in the sending end relay to close the high-current alarm contacts. Current drops to zero in the PM-23 relay monitoring coil to close the low-current alarm contacts.

If the pilot wire should be opened and reclosed with reversed connections when the PM-23 relay is in service, the alarm contact (2) in the PM-23 drops out. The alarm contact dropping out shunts the trip unit coil (3), and prevents the trip unit contact (3) from operating momentarily. The trip unit contact is prevented from operating because the capacitor at the sending end discharges through the pilot wire and the trip unit (3) circuit. This will have no effect on remote trip operation.

The current decreases in both sending and receiving end relays when the PM-2, or PM-4 relays are used. Low current alarm contacts close.

Grounds

The voltage-divider circuit of the PMA, PMD, and PMG-13 source relays has its midpoint grounded through a current-limiting resistor. Thus, a pilot-wire ground will cause an increase in current in one coil circuit, and a decrease in the other one. This unbalance in the current flowing through the two windings (5) of the ground alarm relay unit will cause it to close one of its contacts (depending on which pilot wire is grounded) to give an alarm. Grounds of 10,000 ohms or less will be detected.

TYPE PM MONITORING RELAYS

For adding the sensitive ground detection where PMA-1, PMD-1, or PM-13 relays have been installed, the PM-5 relay can be added to the circuitry, as shown in figure 24. This relay also has a 10,000-ohm ground sensitivity.

Transferred Tripping

Breakers located at the PMG-13 or PM-13 and PM-3 or PM-23 stations can be tripped by the application of a d-c voltage to the pilot wires at remote locations, as shown in figures 21 to 27. Transferred tripping can be effected from any location by applying 48 volts d-c (through dropping resistors when required) to the pilot wire with polarity opposite to that of the monitoring voltage. When tripping the PM-23, the current is increased above 2.0 ma, in reverse direction, to close the trip contact. When tripping the PMG-13 or PM-13, the reversed d.c. voltage operates the trip unit (3).

See Tables II and III for tripping resistor values. Nominal tripping currents is 5ma. at all rated voltages.

Polar Unit

Polar unit flux paths are shown in figure 1. With balanced air gaps, permanent magnet flux flows in two paths, one through the front, and one through the rear gaps. This flux produces north and south poles, as shown. By turning the left shunt in, some of the flux is forced through the armature, making it a north pole. Thus, reducing the left hand rear gap will produce a force tending to pull the armature to the right. Similarly, reducing the right hand gap will make the armature a south pole and produce a force tending to pull the armature to the left.

The alarm unit contacts of the sending and receiving end relays are biased to move to the left when the relay is deenergized. The PMG-13 or PM-13 and PM-23 trip unit contact is biased to move to the left when the relay is deenergized. The PM-5 is adjusted so that the moving contact floats when the relay is deenergized.

CHARACTERISTICS

Nominal Calibration Values

Nominal current values to close contacts are listed in Tables IV and V.

Voltage Ratings

Supply voltage ratings of the monitoring source

relays to obtain continuous monitoring current are as follows:

DC - 48, 125, and 250 volts

AC - 120 volts, 60 cycles (Primary taps 100, 110, 120 & 130)

Voltage impressed on the pilot wire is a nominal 20 volts for monitoring, and 48 volts for tripping.

Supply voltage ratings to obtain remote tripping are: 48, 125, and 250 volts d-c.

Coil Resistance (each winding)

Alarm coil (1)	
two terminal line	1050-1250 ohms
three terminal line	700-900 ohms
Alarm coil (2)	2200-2600 ohms
Trip coil (3)	1800-2200 ohms
Ground Alarm coil (5)	5200-5800 ohms

PM-4 and PM-23 Resistance

Nominal PM-4 and PM-23 total resistance when adjusted for service is 20,000 ohms less pilot wire loop resistance at 1 ma.

PMA, PMA-1 and AC PMG-13, PM-13 Burden

0.5 VA at tap voltage	-	2-terminal line relay
1.0 VA at tap voltage	-	3-terminal line relay

Rectifiers

Approximate forward resistance -	560 ohms at 1 ma
	300 ohms at 2 ma

Rating

Continuous forward current - amperes	- 1
--------------------------------------	-----

Continuous back voltage - rms volts	- 200
-------------------------------------	-------

Remote Tripping

Remote trip resistors are listed in Table II and III for 48, 125, and 250 volts d-c.

The relays have sufficient thermal capacity to withstand 20 MA d-c continuously when remote tripping. Nominal trip currents in the tripping relays are 5.0 MA d-c with 48, 125, and 250 volts d-c supply and a 2000-ohm pilot wire.

TABLE II

**PMA, PMA-1, PMD, AND PMD-1 APPLICATIONS
EXTERNAL RESISTORS FOR D.C. REMOTE TRIPPING
(2 REQUIRED PER STATION)**

# LINE TERMINALS	D.C. VOLTAGE	STATION A PMA or PMA-1	STATION A PMD or PMD-1	STATION B PM-2 & PM-3 or PM-23 or PM-4	STATION C PM-2 & PM-3 or PM-23 or PM-4	TO OPERATE
2	48	200	200	—	—	PM-23 or PM-3
	125	3550	3550	—	—	"
	250	9300	9300	—	—	"
3	48	200	200	—	—	"
	125	2000	2000	—	—	"
	250	5600	5600	—	—	"

TABLE IIIA

**PMG-13 AND PM-13 (D.C. SUPPLY) APPLICATIONS
RESISTORS FOR D.C. REMOTE TRIPPING
(2 REQUIRED PER STATION)**

# LINE TERMINALS	D.C. VOLTAGE	STATION A PMG-13 or PM-13	STATION B PM-2 & PM-3 or PM-23 or PM-4	STATION C PM-2 & PM-3 or PM-23 or PM-4	TO OPERATE
2	48	200 †	200	—	PMG-13 or PM-13 and PM-23 or PM-3
	125	2120 †	2120	—	"
	250	5600 †	5600	—	"
3	48	200 †	200	200	"
	125	1500 †	1500	1500	"
	250	4000 †	4000	4000	"

† Mounted in Relay

TABLE IIIB

**PMG-13 AND PM-13 (A.C. SUPPLY) APPLICATIONS
(2 REQUIRED PER STATION)
RESISTORS FOR D.C. REMOTE TRIPPING**

# LINE TERMINALS	D.C. VOLTAGE	STATION A PMG-13 or PM-13	STATION B PM-2 & PM-3 or PM-23 or PM-4	STATION C PM-2 & PM-3 or PM-23 or PM-4	TO OPERATE
2	48	200 †	200	—	PMG-13 or PM-13 and PM-23 or PM-3
	125	2120 †	2120	—	"
	250	5600 †	5600	—	"
3	48	200 †	200	200	"
	125	1500 †	1500	1500	"
	250	4000 †	4000	4000	"

† Mounted in Relay

TABLE IV

NOMINAL CALIBRATION VALUES – TWO TERMINAL LINES

<u>RELAY</u>	<u>LOW CURRENT ALARM</u> ¹	<u>HIGH CURRENT ALARM</u> ²	<u>TRIP</u>
PMA or PMA-1	0.7 ma	1.3 ma	—
PMD or PMD-1	0.7	1.3	—
PM-5 †	—	±0.3	—
PMG-13 or PM-13	0.7 ††	1.3 ††	14 V.
PM-23 or PM-2 & PM-3 †	0.7	—	14 V.

† Same relay as for three-terminal lines

†† These are pilot-wire current values

1—Left-hand contacts, front view.

2—Right-hand contacts, front view.

TABLE V

NOMINAL CALIBRATION VALUES – THREE TERMINAL LINES

<u>RELAY</u>	<u>LOW CURRENT ALARM</u>	<u>HIGH CURRENT ALARM</u>	<u>TRIP</u>
PMA or PMA-1 •	1.7 ma	2.3 ma	—
PMD or PMD-1	1.7	2.3	—
PM-5 †	—	±0.3	—
PMG-13 or PM-13	1.7 ††	2.3 ††	14 V.
PM-23 or PM-2 & PM-3 †	0.7	—	14 V.

† Same relay as for two-terminal lines

†† These are pilot-wire current values

Trip Circuit

The main contacts will safely close 30 amperes at 250 volts d-c and the seal-in contacts of the indicating contactor switch will safely carry this current long enough to trip a circuit breaker.

The indicating contactor switch has two taps that provide a pickup setting of 0.2 or 2 amperes. To change taps requires connecting the lead located in front of the tap block to the desired setting by means of a screw connection.

Trip Circuit Constant

Indicating Contactor Switch (ICS)

0.2 ampere tap 6.5 ohms d-c resistance

2.0 ampere tap 0.15 ohms d-c resistance

SETTING THE RELAY

Operating units of all relays are adjusted in the factory to the values listed in Tables IV and V to a tolerance of ±5%. No settings are required on these units.

For all 48/125-volt d.c. relays, connect jumpers across resistors as shown on the internal schematics.

PM-4, PM-2, and PM-23 Relays

Adjust the resistors in the PM-4, PM-2, or PM-23 relay or relays to a value of 1 MA d-c with the monitoring circuits connected for service. Use the milliammeter in the PM-23 for this purpose or use a portable milliammeter with a resistance of less than 200 ohms. Where it is not practical on three-terminal lines to adjust both receiving relays simultaneously, set one receiving relay for 18,000 ohms total resistance (including relay coil and resistors) by measurement prior to final adjustment of the other receiving relay. This procedure will minimize the change in monitoring current in the first relay to be adjusted when making the final adjustment of the second relay.

PMA, PMA-1, PMG-13 and PM-13 Relays

Select the transformer tap nearest to expected normal a-c supply voltage. The full wave rectifier is

connected to a secondary transformer tap. Where desired, the output voltage can be raised about 5% by reconnecting across the full secondary winding.

Indicating Contactor Switch

No setting is required on the ICS unit except the selection of the 0.2 or 2.0 ampere tap setting. This selection is made by connecting the lead located in front of the tap block to the desired setting by means of the connecting screw. When the relay energizes a type WL relay switch, or equivalent, use the 0.2 ampere tap.

INSTALLATION

The relays should be mounted on switchboard panels or their equivalent in a location free from dirt, moisture, excessive vibration, and heat. Mount the relay vertically by means of the four mounting holes on the flange for semi-flush mounting or by means of the rear mounting stud or studs for projection mounting. Either a mounting stud or the mounting screws may be utilized for grounding the relay. The electrical connections may be made directly to the terminals by means of screws for steel panel mounting or to the terminal studs furnished with the relay for thick panel mounting. The terminal studs may be easily removed or inserted by locking two nuts on the stud and then turning the proper nut with a wrench.

For detailed FT case information, refer to I.L. 41-076.

Where the potential to ground impressed on the relays can exceed 700 volts, a drainage reactor in conjunction with a KX-642 tube, or the reactor in conjunction with 700 volt carbon-block arresters, is recommended. For details, see Protection of Pilot-Wire Circuits, AIEE Committee Report, paper 58-1190, AIEE Transactions, 1959, Volume 78, Part III B pp. 205-212. Also, see AIEE Special Publication S-117, Applications and Protection of Pilot-Wire Circuits for Protective Relaying, July 1960.

ADJUSTMENTS AND MAINTENANCE

The proper adjustments to insure correct operation of this relay have been made at the factory and should not be disturbed after receipt by the customer. If the adjustments have been changed, the relay taken apart for repairs, or if it is desired to check the adjustments at regular maintenance periods, the instructions in the succeeding sections should be followed.

Acceptance Tests

The following tests are recommended when the relay is received from the factory. If the relay does not perform as specified below, the relay either is not properly calibrated or it contains a defect.

Indicating Contactor Switch (ICS)

Close the contact of the tripping unit and pass sufficient direct current through the trip circuit to close the contacts of the ICS unit. This value of current should not be greater than the particular ICS tap setting being used (0.2 or 2.0). The indicator target should drop freely.

PMA and PMA-1 Relays

Alarm Unit (1)

Set the primary tap on 120 volts. Connect a variable resistor of approximately 20,000 ohms in series with a low-range d-c milliammeter across terminals 6 and 7 with the instrument positive connected to terminal 7. Apply 120 volts at rated frequency to terminals 4 and 5. Adjust the 20,000-ohm resistor to obtain a current of one ma. d.c. For a three-terminal line relay, use a 10,000-ohm resistor and set the current to 2 ma. d.c. At this value, the moving contact of the alarm or monitoring relay unit (1) should float between the two sets of stationary contacts. In the PMA relay, the ground alarm unit (5) contact should also float. (This contact will also float when the relay is de-energized.) Increase and decrease the one or two-milliampere monitoring current to check the calibration values listed in Tables IV and V.

Ground Unit (5)

Reconnect the 20,000-ohm resistor. For the PMA relay only, short terminals 7 and 3. The contact of the ground alarm unit (5) should close to the right when the relay is energized. Remove the short, and connect it between terminals 6 and 3. The ground alarm unit (5) should close to the left. The action of the monitoring unit (1) contact is of no significance in this simulated pilot-wire ground test. To check the pickup current of the ground detector, first remove the 20,000-ohm resistor from terminals 6 and 7. Connect a 0-1 d.c. milliammeter in series with a variable resistor of about 50,000 ohms between terminals 3 and 6. The ground unit should close its left-hand contact at approximately 0.3 ma. d.c. With the milliammeter and resistor connected between terminals 3 and 7, the right-hand contact should close at 0.3 ma. d.c.

TYPE PM MONITORING RELAYS

PMD and PMD-1 Relays

Alarm and Ground Units

Connect an adjustable 20,000-ohm resistor (or 10,000-ohms for a 3-terminal relay) in series with a d-c milliammeter across terminals 6 and 7 with the instrument positive connected to terminal 7. Apply rated d-c voltage to terminals 8 and 9 with positive on terminal 9. Now check the PMD and PMD-1 relays, following the procedure given in the previous section for the PMA and PMA-1 relays, respectively. Note, however, that terminal 5 of the PMD relay corresponds to terminal 3 of the PMA relay.

PM-2, PM-3, and PM-23 Relays

Alarm Unit (2)

Apply a variable d-c voltage of approximately 20 volts to relay terminals 8 and 9 (terminal 9 positive) of the PM-2 or PM-23 relay. Adjust the voltage to obtain a reading of one ma. on the relay milliammeter. The monitoring polar unit (2) contacts should float. Reduce the current gradually. The monitoring alarm contacts should close at 0.7 ma. d.c. The tripping unit (3) of the PM-23 relay should not move during this test. The milliammeter has been adjusted to read 1 ma. $\pm 5\%$. As a result the pointer may not read zero for a zero current condition.

Tripping Unit (3)

To check the PM-3 relay or the tripping unit of the PM-23 relay, apply the variable d-c voltage in series with an external milliammeter to relay terminals 8 and 9 with terminal 8 positive for the PM-23 relay, or terminal 9 positive for the PM-3 relay. When checking the pickup of the PM-23 trip unit block open the alarm unit contacts (2) so as to remove the shunt resistor from around the trip coil (3).

The tripping relay unit (3) should pick up with positive action at 14 volts d.c. and should drop out at approximately 10 volts. The alarm unit of the PM-23 relay will not operate during this test.

PM-4 Relay

This device is simply a set of resistors and a diode to connect into the pilot-wire circuit to provide a path for the monitoring current. The resistors can be checked with an ohmmeter, and the diode can be checked either with an ohmmeter, or as explained in the section entitled "Rectifier Check" under "Routine Maintenance". If an ohmmeter is used, the difference in forward and reverse resistance readings obtained will be dependent on the current flowing through the diode.

PM-5 Relay

Apply 5 volts d.c. in series with a 0-1 d.c. milliammeter and a 20,000-ohm variable resistor to terminals 6 and 7 with positive on terminal 6. The left-hand contact should close at approximately 0.3 ma. Now apply the same circuit to terminals 8 and 9 with positive on terminal 9. The right-hand contact should close at approximately 0.3 ma.

PM 13 Relays - A.C. and D.C.

Alarm Unit (1)

Connect a variable 20,000-ohm resistor (10,000 ohms for a 3-terminal-line relay) in series with a d-c milliammeter across terminals 8 and 9 with the instrument positive on terminal 9. For the a-c relay, set the primary tap on 120 volts. Now apply the rated supply voltage to terminals 4 and 5. This will be 48, 125, or 250 volts d.c., or 120 volts a.c. as indicated on the relay nameplate. Adjust the variable resistor to obtain a current of one ma. for a 2-terminal line relay, or 2 ma. for a 3-terminal relay. At this value, the moving contacts of the alarm or monitoring (1) relay unit (the upper polar unit) should float between the two sets of stationary contacts. Increase and decrease the one or 2 ma. monitoring current to check the calibration values listed in Tables IV and V.

Tripping Unit (3)

To check the operation of the tripping unit 3 (the lower polar unit), apply a d.c. potential across terminals 16 (positive) and 20 (negative). The tripping polar unit should pick up at 14 volts, and should drop out at approximately 10 volts. The resistance of the series dropping resistors for transferred tripping (listed in Tables III A and III B) can be checked with an ohmmeter. The circuit location of these resistors can readily be seen from the external schematic, Figure 27.

PMG-13 Relays - A.C. and D.C.

Alarm and Tripping Units

Follow the procedure given in the previous section for the a-c. and d-c. PM-13 relays.

Ground Unit (5)

Connect the 20,000-ohm (or 10,000-ohm) resistor and milliammeter across terminals 8 and 9. With rated voltage applied and one ma. (or 2 ma.) flowing, successively short circuit terminals 3 and 8, then 3 and 9. The ground alarm unit 5 (lower polar unit) should move first to the left, then to the right. To check the pickup current of the ground detector, first remove the 20,000-ohm resistor from terminals 8 and 9. Connect a 0-1 d.c. milliammeter in series

with a variable resistor of about 50,000 ohms between terminals 3 and 8. The left-hand contact should close at approximately 0.3 ma. d.c. With the milliammeter resistor connected, between terminals 3 and 9, the right-hand contact should close at 0.3 ma. d.c. The external schematic diagrams for these relays are shown in Figure 23 and 25.

Routine Maintenance

CAUTION - Do not make any performance check, calibration tests, or adjustments while the PM relays are energized or connected to the pilot wires, to prevent the possibility of inadvertently causing a break operation. The PM relays may be removed from service for testing, without jeopardizing HCB relay protection, providing that the connections between the 10-mfd capacitor and the HCB insulating transformer are not disturbed.

Contacts

All contacts should be periodically cleaned. A contact burnisher S#182A836H01 is recommended for this purpose. The use of abrasive material for cleaning contacts is not recommended because of the danger of embedding small particles in the face of the soft silver and thus impairing the contact.

Operational Check

In addition to cleaning contacts, it is recommended that an operational check be performed periodically by opening and short-circuiting the pilot wires, as well as grounding them at the relay terminals. **Note:** These pilot-wire faults should not be applied directly to the pilot wires when the HCB relays are in service. It is also recommended that the trip circuits of the PM relays be opened (where tripping is used), to prevent the possibility of inadvertently tripping the associated circuit breaker during testing. If the relays do not perform as expected, and diode failure is suspected, the diode tests described in the following section may be performed.

Rectifier (Diode) Check

If there is suspicion of a rectifier (diode) failure, apply 30 volts d.c. reverse voltage (positive on arrowhead) through a 300-ohm resistance to the diode. Measure the voltage across the diode. If this voltage is not essentially 30 volts, the diode is short-circuited. Now apply 30 volts d.c. in the forward direction through the 300-ohm resistor, and measure the voltage across the resistor. If the voltage is not essentially 30 volts, the diode may have a high forward resistance. If the voltage is zero, the diode is open-circuited.

Calibration

If the relay has been dismantled or the calibration has been disturbed, use the following procedure for calibration.

With the permanent magnet removed, see that the moving armature floats in the central area of the air-gap between the poles of the polar unit frame. If necessary, loosen the core screw in the center rear of the unit and shift the core and contact assembly until the armature floats. (This can best be done with the polar unit removed from the relay.) Then retighten the core screw and replace the permanent magnet with the dimple (north pole) on the magnet to the left when viewed from the front.

Polar Units-General

The following mechanical adjustments are given as a guide, and some deviation from them may be necessary to obtain proper electrical calibration.

Magnetic Shunt Adjustment

The sensitivity of the polar unit is adjusted by means of two magnetic, screw-type shunts at the rear of the unit, as shown in Fig. 1. These shunt screws are held in proper adjustment by a flat strip spring across the back of the polar unit frame, so no locking screws are required. Looking at the relay, front view turning out the right-hand shunt to open the right-hand air gap decreases the amount of current required to close the right-hand contact. Conversely, drawing out the left-hand shunt increases the amount of current required to close the right-hand contact, or decreases the amount of current required to close the left-hand contact (with the proper direction of current flow). Also, if a relay trips to the right at the proper current, the dropout current can be raised by turning in the right-hand shunt. The two shunt-screw adjustments are not independent, however, and a certain amount of trimming adjustment of both shunt screws is generally necessary to obtain the desired pickup and dropout calibration.

In general, the farther out the two shunt screws are turned, the greater the toggle action will be, and as a result, the lower the dropout current. For the tripping units (3) of the PM-3, PM-13, and PM-23 relays, toggle action is desirable, with a dropout current around 75 percent of the pickup current. For the monitoring alarm relay units, toggle action is not desired. Instead, the armature is adjusted to float between the pole faces at a given current (1 or 2

TYPE PM MONITORING RELAYS

The following chart indicates the units present in each relay.

FUNCTION AND UNIT	PMA PMD	PMA-1 PMD-1	PM2	PM3	PM4	PM5	PM13	PMG13	PM23
Alarm for p.w. open, short or reversal (1) (2)	X	X	X				X	X	X
Transfer-Trip Unit (3)				X			X	X	X
Alarm for p.w. ground (5)	X					X		X	
D.C. Path for Monitoring Current					X				

ma.), and to move gradually toward the high or low-current alarm as the coil current is increased or decreased. Similarly, the floating adjustment of the armature of the ground alarm unit (5) requires that both shunt screws be turned in relatively far. Then the armature will move gradually to the left or right as the current through the two #5 coils is unbalanced.

The electrical calibration of the polar unit is also affected by the contact adjustment as this changes the position of the polar unit armature. Do not change the contact adjustment without rechecking the electrical calibration.

Contact Adjustment - All Relays

For all monitoring alarm units, designated (1) or (2), turn in all the stationary contact and contact stop screws until they just touch the moving contact. Advance the screws to hold the armature in the central portion of the magnetic air gap between the two pole faces. (The stationary contact screws have a round silver contact face; the stop screws do not have this silver facing.) Now back off all the contact and contact stop screws one full turn. This will give a total contact travel of 0.050 inch. When the relay is properly calibrated, some touch-up adjustment may be necessary so that double contacts will both close at the same current value. The contact gap between the floating moving contact and the right-hand or left-hand stationary contacts or contact stops will be approximately 0.025 inch when the relay is in operation.

For the tripping (3) units of the PM-3, PM-13, PMG-13, and PM-23 relays, adjust the contacts as described in the previous paragraph, except back off the contact and stop screws one-half turn each to

give a total moving contact travel of approximately 0.025 inch. In operation of the tripping unit, the moving contact will normally rest against the contact stop screws, and will pick up only for a transferred-tripping operation.

For the pilot-wire ground alarm unit (5) of the PMA, PMD, PM5, and PMG-13 relays, follow the same general procedure except back off both stationary contact screws two turns each. This will give a contact gap of 0.050 on each side of the moving contact when it is its normal central position.

Electrical Calibration - All Relays

In the following sections, the calibration instructions are given for the polar unit which performs a certain function, such as alarm (1) or (2), ground (5), or trip (3), rather than giving calibration instructions for each complete relay. In this way, considerable duplication of instructions has been eliminated.

Alarm Unit (1)

Connect the relay as described under Acceptance Tests for the particular relay involved. Screw the two magnetic shunts all the way in, then back them out five turns each. With the relay energized at rated voltage, set the monitoring current at 1.3 or 2.3 ma. d.c. for 2 or 3-terminal relay respectively, by adjusting the external resistor. If the relay does not close its right-hand contact, turn in the left shunt screw until the right-hand contact just closes. If the right-hand contact is closed at 1.3 ma., turn in the right shunt until a point is reached when the right-hand contact is just closed at 1.3 ma.

Now drop the current to 0.7 ma. and adjust the opposite shunt until the left-hand contact just closes

at 0.7 ma. d.c. At 1.0 ma. d.c., the moving contact should float half way between the two sets of stationary contacts with a 0.025-inch gap on each side. Recheck the high and low current calibration several times, touching up the shunt adjustments as required to obtain the desired calibration.

Polarization Check

For all the source relays, which are listed below, make the following additional calibration check:

- PMA PM-13 (a.c. and d.c.)
- PMA-1 PMG-13 (a.c. and d.c.)
- PMD
- PMD-1

After calibration as described in the previous sections, connect a 20,000 ohm resistor (or 10,000 ohms for 3-terminal applications) across the output terminals, and energize the relay at its rated supply voltage. With these connections, approximately one (or two) milliamperes d.c. will flow through the monitor relay coils and external resistor, thus representing normal operating conditions.

Now momentarily (one second or so) apply 48 volts d.c. directly to the pilot-wire terminals of the relay, as indicated in the following table.

Relay	Terminals for Momentary Application of 48 V. d.c.	
	POS.	NEG.
PMA, PMA-1 } PMD, PMD-1 }	6	7
PM-13 (a.c. or d.c.) } PMG-13 (a.c. or d.c.) }	8	9

After momentary application of the transfer-trip voltage as just explained, recheck the calibration of the monitoring alarm unit (1). If it has changed, make necessary trimming adjustments of the shunt screws until there is no change in calibrating of the alarm unit (1) after the transfer-trip voltage has been applied. The purpose of this test is to compensate for the small residual magnetism in the relay unit. The ground alarm unit (5) will not be affected by this test as the ampere-turns of the two windings cancel each other.

Alarm Unit (2)

For the alarm unit of the PM-2 or PM-23 relays, adjust the shunts so that the relay moving contact

floats at one ma. d.c., and closes the left-hand contact at 0.7 ma. d.c. The moving contact should float midway between the contact and contact stop at 1.0 ma. d.c. There is no high-current calibration for this relay unit.

Now apply 48 volts d.c. momentarily (one second or so) across the alarm unit coil-circuit terminals in a direction to operate the alarm relay. Then recheck the alarm unit calibration. If there is any change, touch up the shunt adjustments until there is no change in calibration after 48 v. d.c. has been applied.

Tripping Unit (3)

To calibrate the tripping unit of the PM-3, PM-13, PMG-13, or PM-23 relays apply a d.c. voltage as explained below, to the following relay terminals:

Relays	D.C.	Voltage
	Pos.	Neg.
PM-3	9	8
PM-13 (a.c. or d.c.)	16	20
PMG-13 (a.c. or d.c.)	8	9
PM-23	8	9

Momentarily (one second or so) apply 48 volts d.c. to the terminals shown in the chart. Then starting with both shunts all the way in, turn out the right-hand shunt screw until the relay closes its right-hand trip contact at 14 volts d.c. (This will give approximately 2 ma. through the relay coil.) Now draw out the left-hand shunt until the relay resets with toggle action (not gradually) at not less than 10 volts d.c. When the calibration is approximately correct, again apply 48 volts d.c. to the indicated terminals, then recheck the pickup and dropout voltage, making any necessary trimming adjustments of the shunts. When the relay is properly adjusted, the application of 48 volts d.c. will not change the pickup or dropout voltage points. The relay should trip and reset with toggle action in this application. This will require both shunt screws to be withdrawn farther than for floating action.

Ground Alarm Unit (5)

For the PM-5 relay, turn both shunt screws all the way in, then back them out five turns each. Pass a current of 0.3 ma. d.c. in terminal 6 and out terminal 7. Following the same general procedure as described previously in the section entitled "Alarm Unit (1)," adjust the shunt screws so that the left-hand contact closes at 0.3 ma. Now pass 0.3 ma. d.c.

TYPE PM MONITORING RELAYS

in terminal 9 and out terminal 8, and adjust for closing of the right-hand contact at 0.3 ma. Recheck both pickup points several times, and make trimming adjustments of both shunts as required to obtain contact closing at 0.3 ma. d.c. in each direction.

For the ground unit (5) of the PMA, PMD, and PMG-13 relays, connect a variable resistance of about 50,000 ohms in series with a 0-1 d.c. milliammeter between the terminals indicated in the following table:

Turn the shunts all the way in, then back them out five turns each. With the relay connected as shown in the left-hand column of the table, apply rated voltage to the relay and adjust the 50,000-ohm resistor for 0.3 ma. d.c. Now following the procedure in the previous paragraph for the PM-5 relay, adjust the shunts until the left-hand contact closes at 0.3 ma. d.c. Change the connections as indicated in the right-hand column, and adjust the opposite shunt until the right-hand contact closes. Recheck back and forth several times and make necessary trimming adjustments to obtain pickup at 0.3 ma. In each direction. The armature will move gradually as the

current is changed for this relay unit.

ICS Unit

Close the main relay tripping contact circuit with a jumper connected directly across the contact terminals of the polar unit. Pass sufficient direct current through the relay trip circuit to close the contacts of the ICS unit. This value of current should not be greater than the ICS tap setting being used (0.2 or 2.0). The indicator target should drop freely. The contact gap should be approximately 0.047 inch between the bridging moving contact and the adjustable stationary contacts. The bridging moving contact should touch both stationary contacts simultaneously.

RENEWAL PARTS

Repair work can be done most satisfactorily at the factory. However, interchangeable parts can be furnished to the customers who are equipped for doing repair work. When ordering parts, always give the complete nameplate data.

Ground Alarm (5) Calibration		
Relay	<u>Relay Terminals</u>	
	L.H. Contact Check	R.H. Contact Check
PMA	3 ⁺ and 6	3 and 7 ⁺
PMD	5 ⁺ and 6	5 and 7 ⁺
PMG-13	3 ⁺ and 8	3 and 9 ⁺

+ Milliammeter positive to this terminal

INDEX TO FIGURES

INTERNAL SCHEMATICS

FIG. NO.		PAGE NO.
1	Polar Unit Permanent Magnet Flux Paths	2
2	PMA Relay - AC supply - two terminal line	14
3	PMA-1 Relay - AC supply - two terminal line	14
4	PMA Relay - AC supply - three terminal line	14
5	PMA-1 Relay - AC supply - three terminal line	14
6	PMD Relay - DC supply - two terminal line	15
7	PMD-1 Relay - DC supply - two terminal line	15
8	PMD Relay - DC supply - three terminal line	15
9	PMD-1 Relay - DC supply - three terminal line	15
10	PM-2 relay in FT21 case	16
11	PM-3 relay in FT11 case	16
12	PM-4 relay (auxiliary unit)	16
13	PM-5 ground detector relay	16
14	PM-23 relay in FT21 case	17
15	PM-13 Relay - DC supply - two terminal line	17
16	PM-13 Relay - DC supply - three terminal line	17
17	PM-13 Relay - AC supply - two or three terminal line	17
18	PMG-13 Relay - DC supply - two terminal line	18
19	PMG-13 Relay - DC supply - three terminal line	18
20	PMG-13 Relay - AC supply - two or three terminal line	18

EXTERNAL SCHEMATICS

21	PMD relay with PM-23 or PM-4, two terminal line	19
22	PMA relay with PM-23 or PM-4, two terminal line	19
23	DC type PMG-13 with PM-23 or PM-4, two terminal line	20
24	PMD relay with PM-23 & PM-4, three terminal line	20
25	AC type PMG-13 relay with PM-23, two terminal line	21
26	DC type PM-13 & PM-5 with PM-23 or PM-4, two terminal line	21
27	DC type PM-13 relay with PM-23 or PM-4, two terminal line	22

OUTLINE & DRILLING PLANS

28	10 mfd. capacitor	23
29	Remote trip resistor	23
30	PM-4 projection molded case	23
31	PM-4 semi-flush molded case	23
32	PM-3, PM-5, & PMD-1 in FT11 case	24
33	PM-2, PM-23, PMA-1, & PMD in FT21 case	25
34	PMA in FT31 case	26
35	PM-13 and PMG-13 in FT32 case	27

TYPE PM MONITORING RELAYS

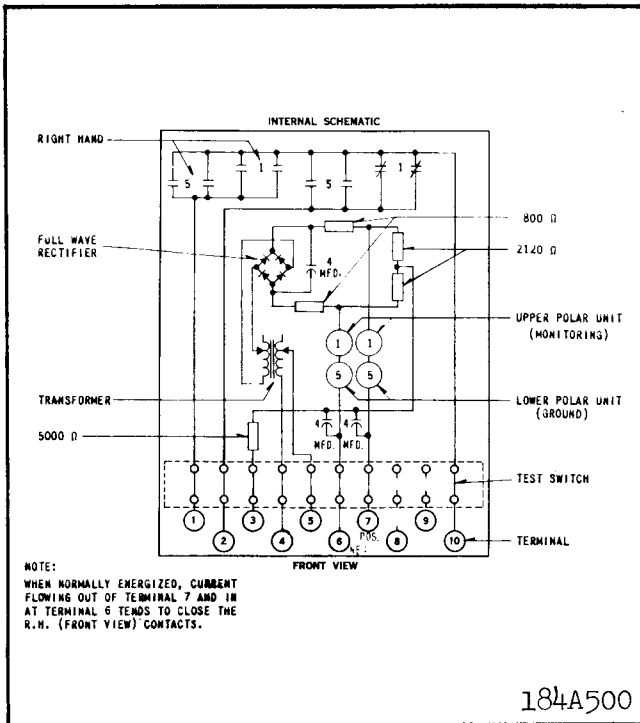

Fig. 2. Internal schematic of the type PMA relay in FT 31 case - 120 volt, 60 cycle supply - For two terminal lines.

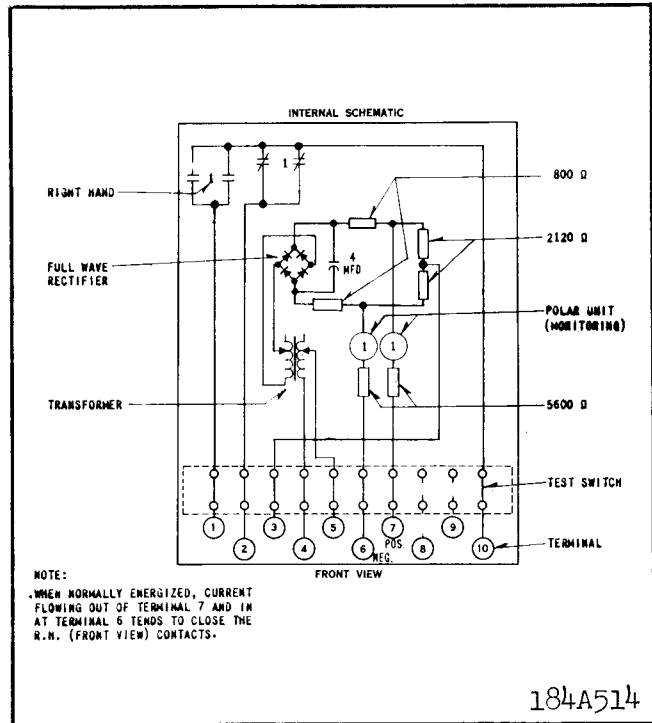

Fig. 3. Internal schematic of type PMA-1 relay in the FT 21 case - 120 volts, 60 cycle supply - For two terminal lines.

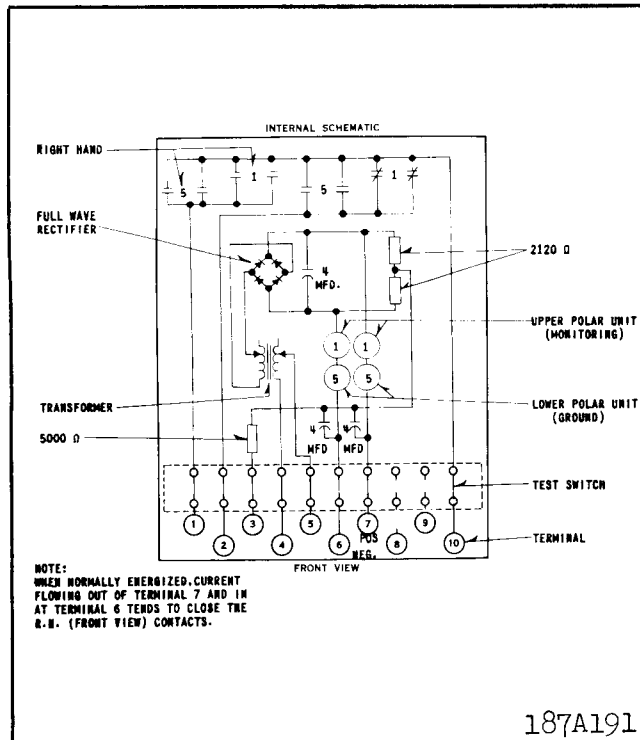

Fig. 4. Internal schematic of type PMA relay in FT 31 case - 120 volt, 60 cycle supply - For three terminal lines.

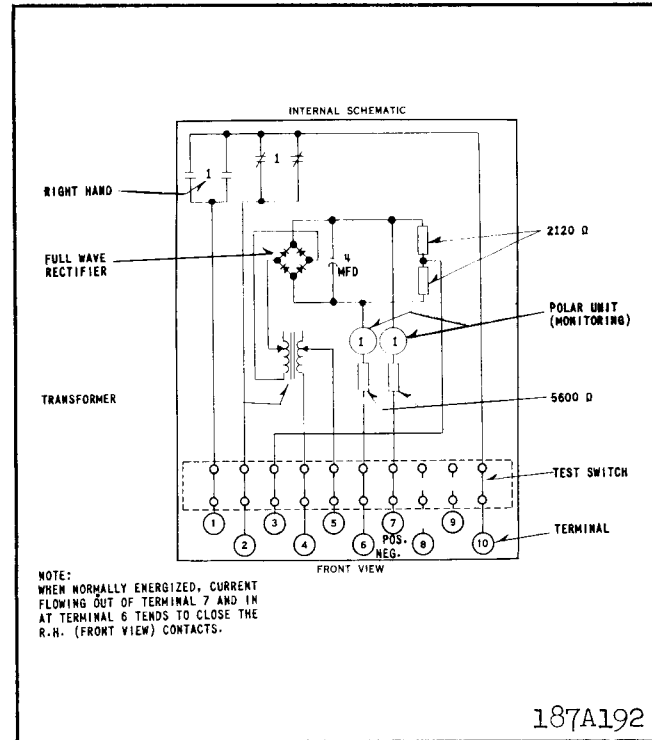

Fig. 5. Internal schematic of type PMA-1 relay in FT 21 case - 120 volt, 60 cycle supply - For three terminal lines.

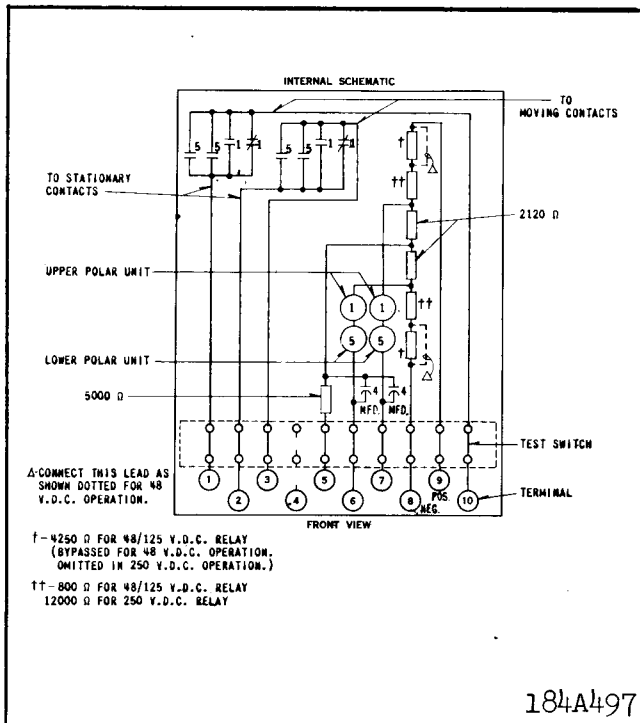

Fig. 6. Internal schematic of the type PMD relay in FT 21 case - DC supply - for two terminal lines.

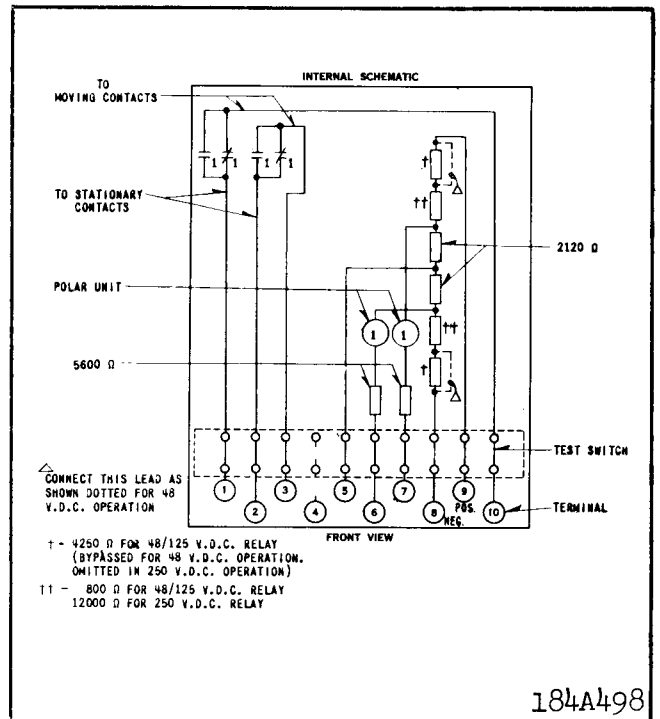

Fig. 7. Internal schematic of the type PMD-1 relay in the FT 11 case - DC supply - For two terminal lines.

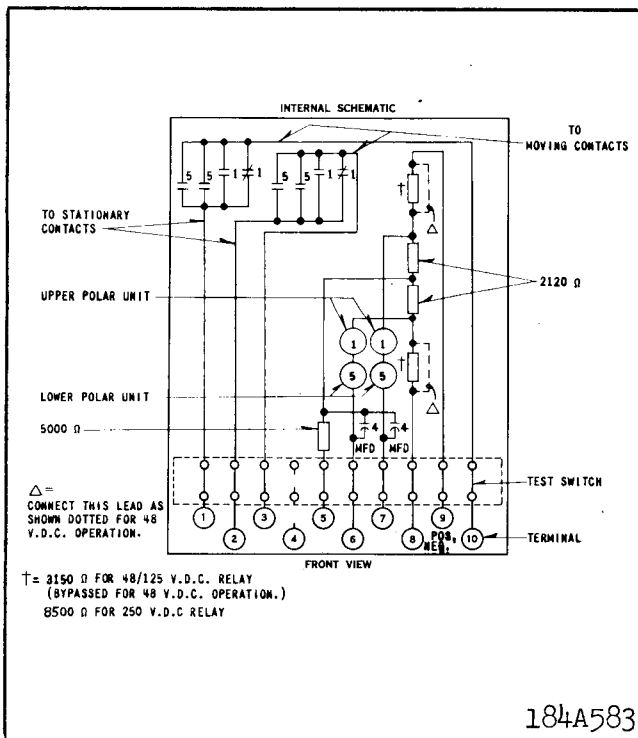

Fig. 8. Internal schematic of the type PMD relay in the FT 21 case - DC supply - For three terminal lines.

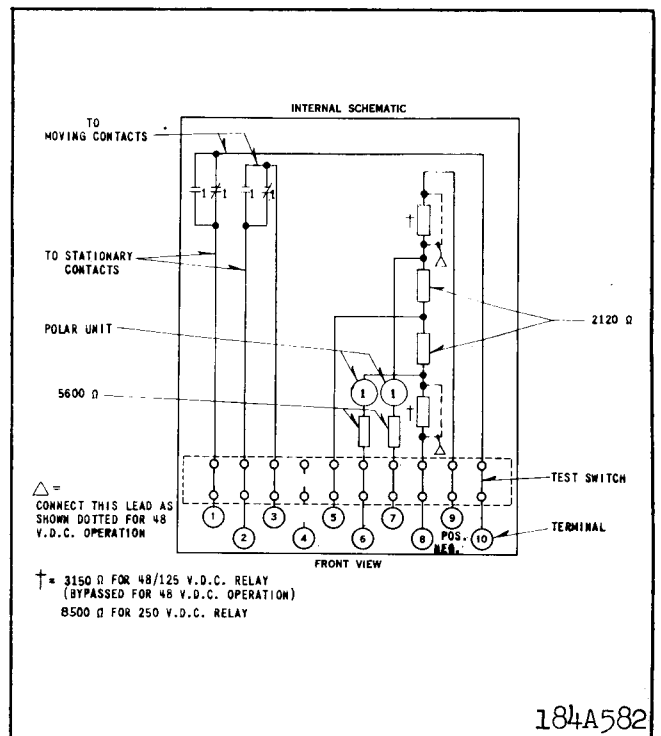

Fig. 9. Internal schematic of the type PMD-1 relay in the FT 11 case - DC supply - For three terminal lines.

TYPE PM MONITORING RELAYS

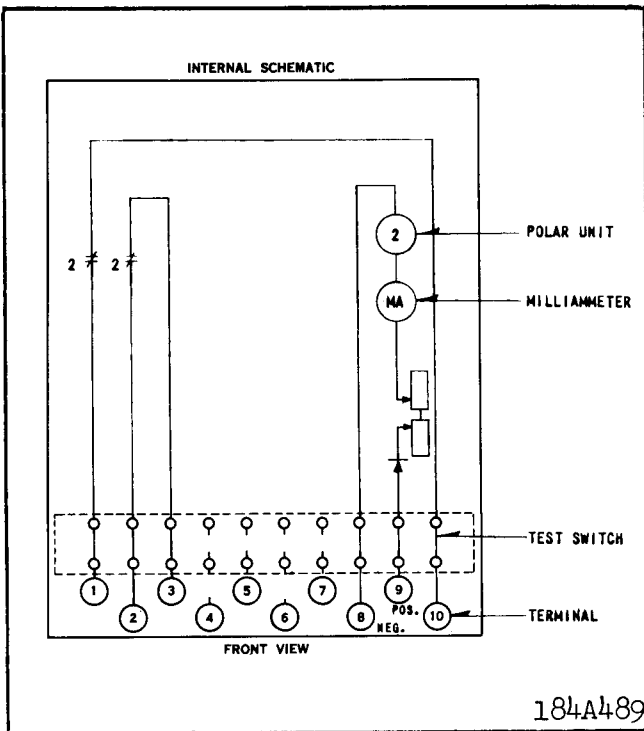

Fig. 10. Internal schematic of the type PM-2 relay in the FT 21 case.

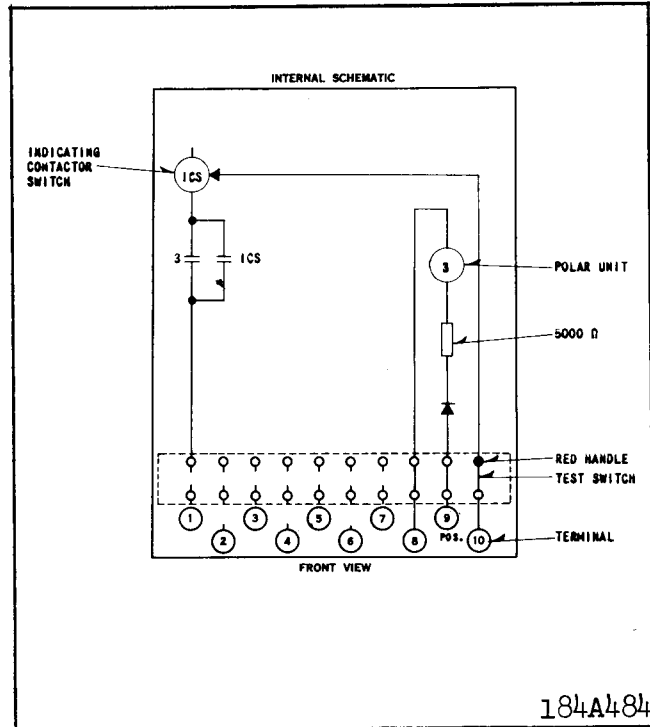

Fig. 11. Internal schematic of the type PM-3 relay in the FT 11 case.

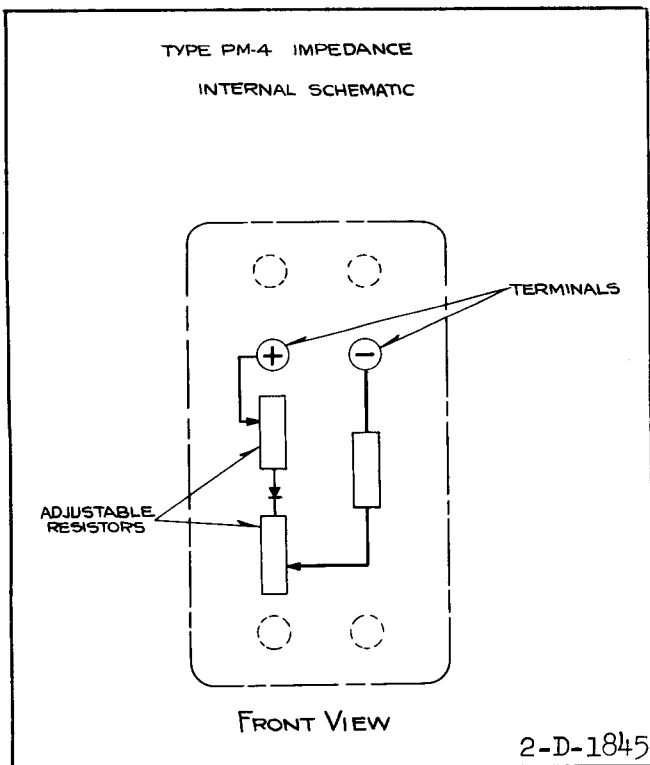

Fig. 12. Internal schematic of the type PM-4 Auxiliary Unit in the small molded case.

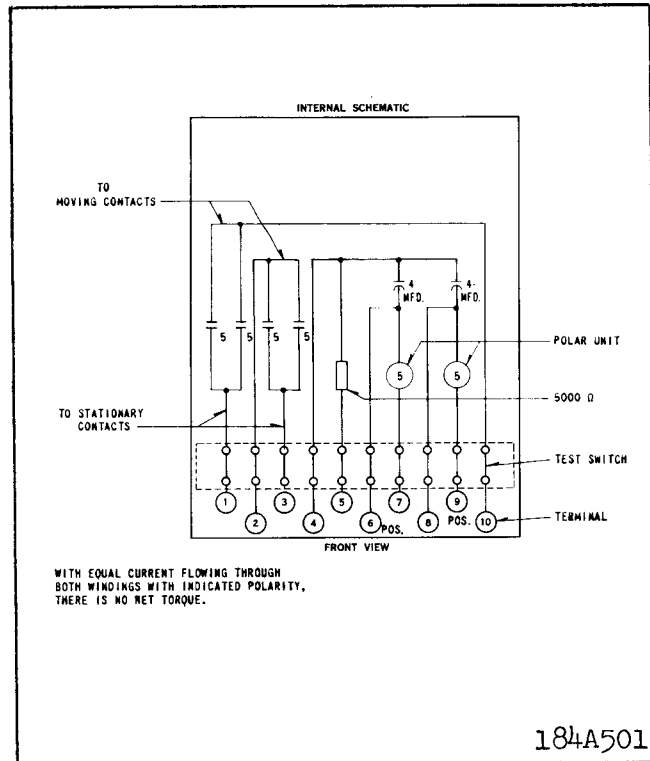

Fig. 13. Internal schematic of the type PM-5 ground detector relay in the FT 11 case.

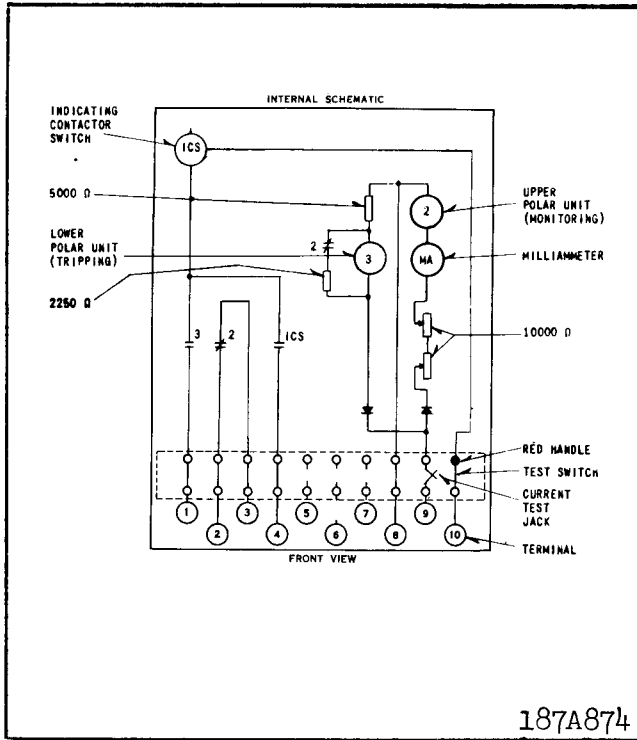

Fig. 14. Internal schematic of the type PM-23 relay in the FT 21 case.

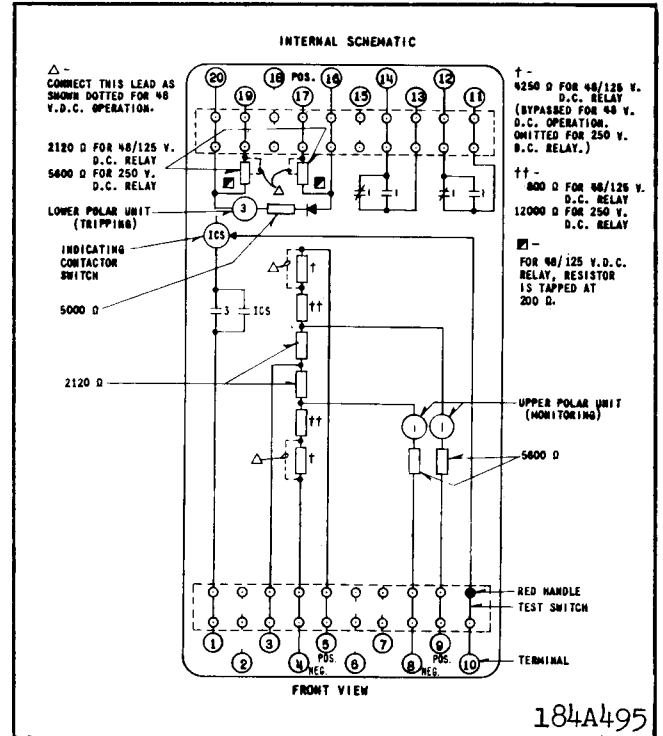

Fig. 15. Internal schematic of the type PM-13 relay in the FT 32 case - DC supply - For two terminal lines.

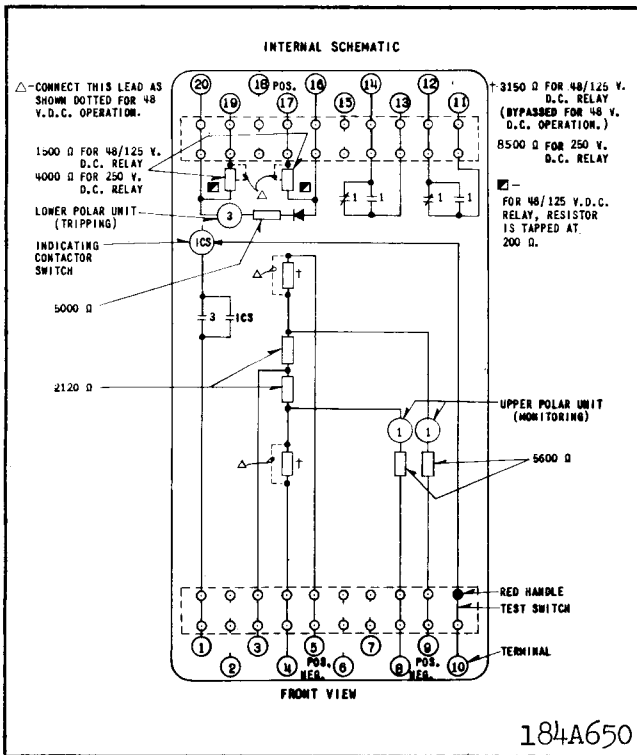

Fig. 16. Internal schematic of the type PM-13 relay in the FT 32 case - DC supply - For three terminal lines.

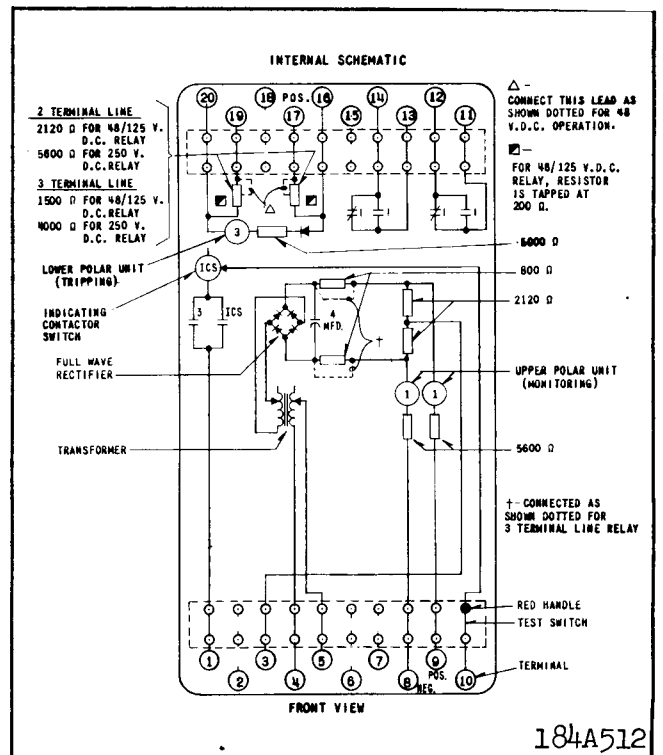

Fig. 17. Internal schematic of the type PM-13 relay in the FT 32 case - 120 volt, 60 cycle supply - For two or three terminal lines.

TYPE PM MONITORING RELAYS

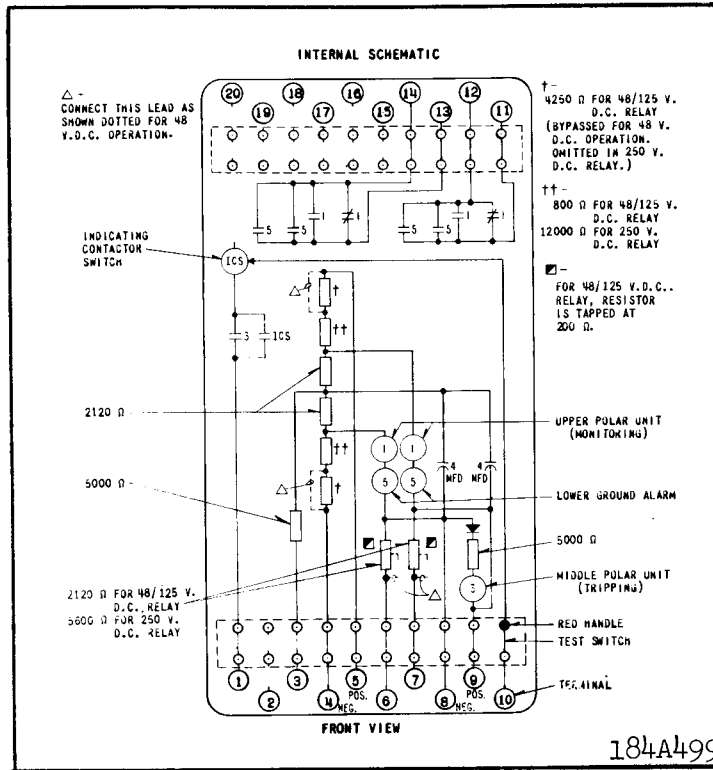

Fig. 18. Internal schematic of the type PMG-13 relay in the FT 32 case - DC supply - For two terminal lines.

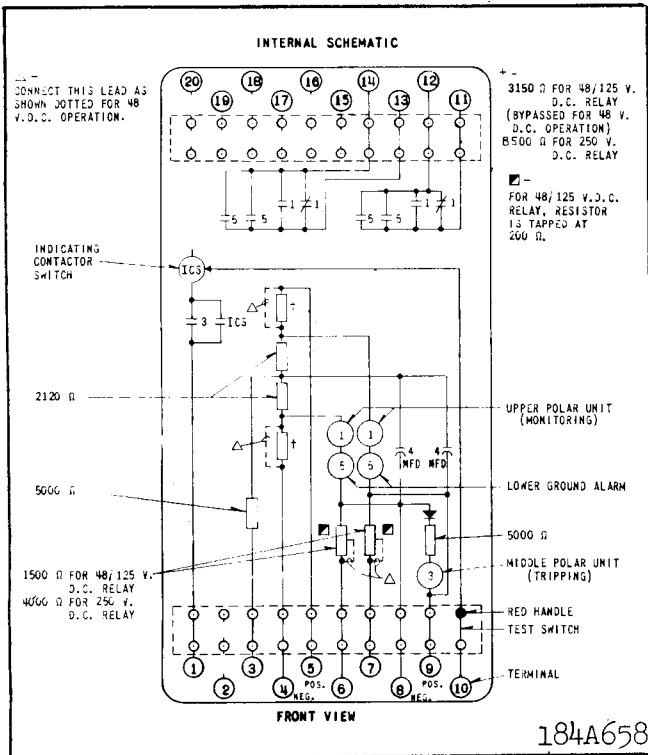

Fig. 19. Internal schematic of the type PMG-13 relay in the FT 32 case - DC supply - For three terminal lines.

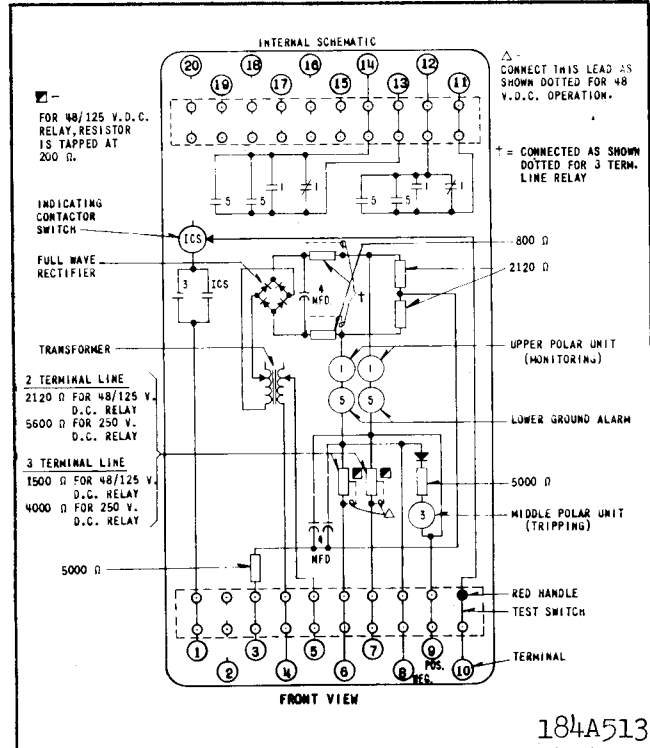

Fig. 20. Internal schematic of the type PMG-13 relay in the FT 32 case - 120 volt, 60 cycle supply - For two or three terminal lines.

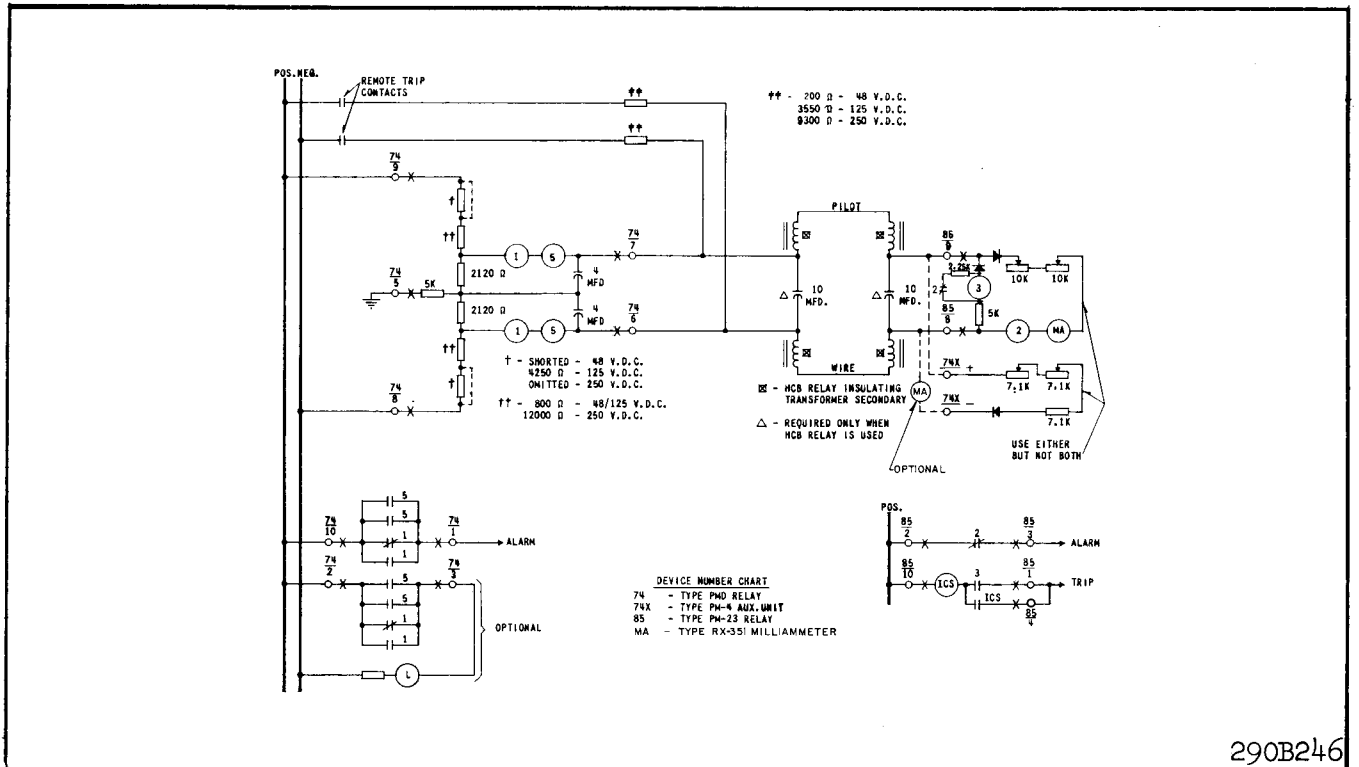

Fig. 21. External schematic of the type PMD relay with type PM-23 or PM-4 relay - Two terminal lines.

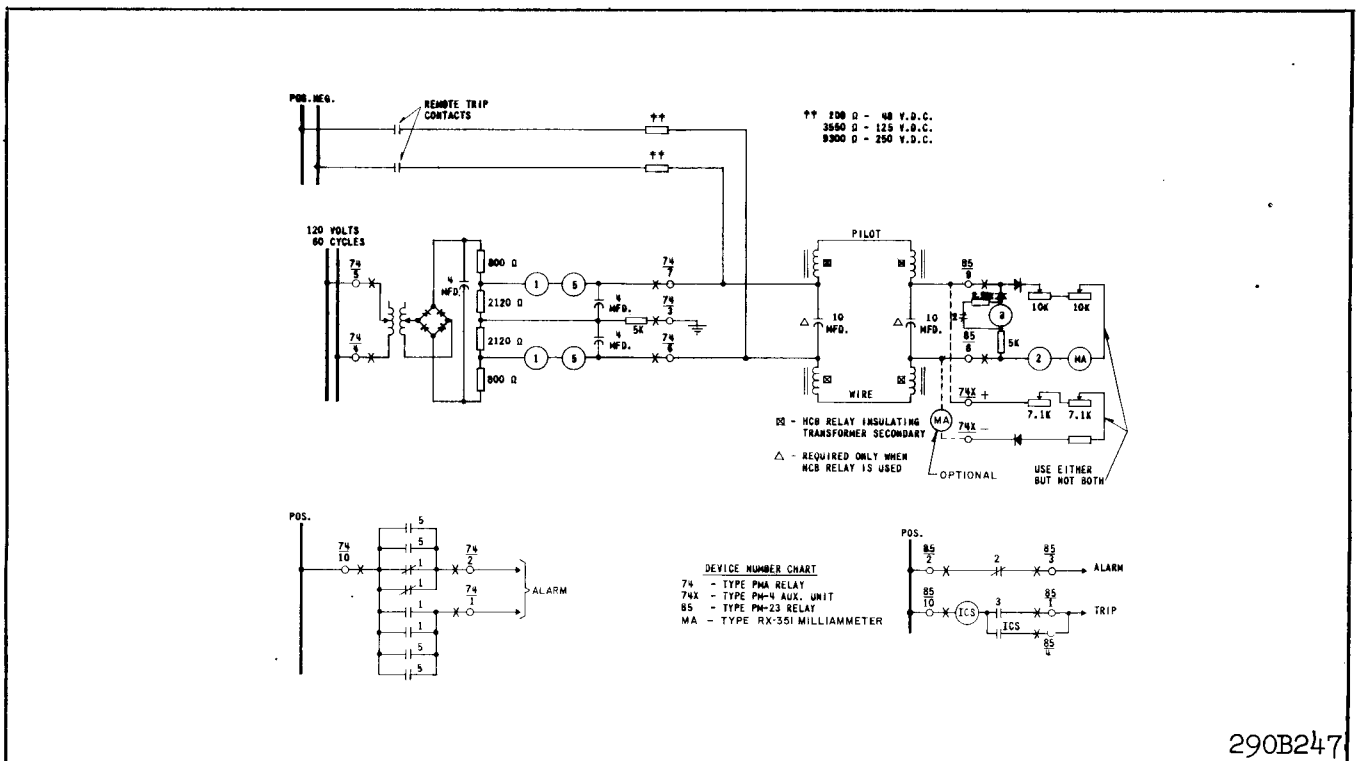

Fig. 22. External schematic of the type PMA relay with type PM-23 or PM-4 relay - Two terminal lines.

TYPE PM MONITORING RELAYS

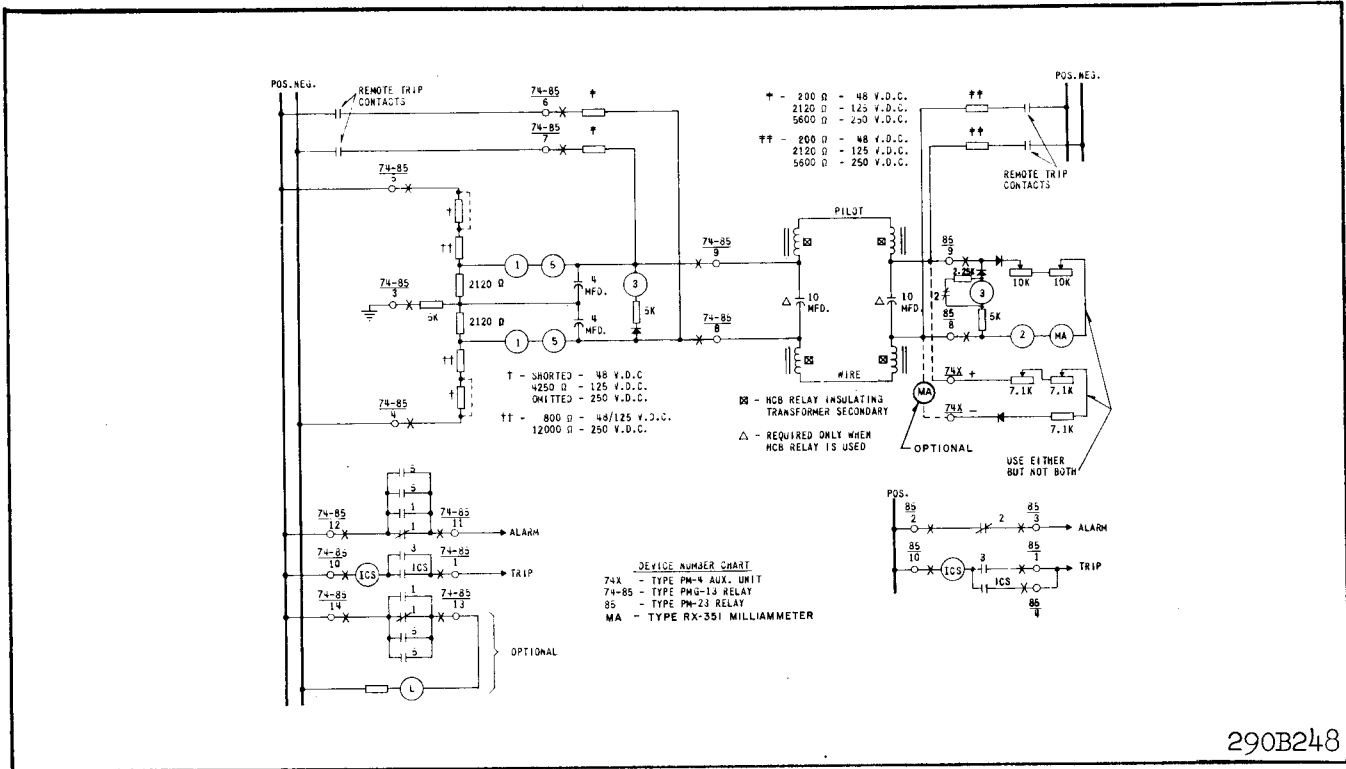

Fig. 23. External schematic of the DC type PMG-13 relay with type PM-23 or PM-4 relay - Two terminal lines.

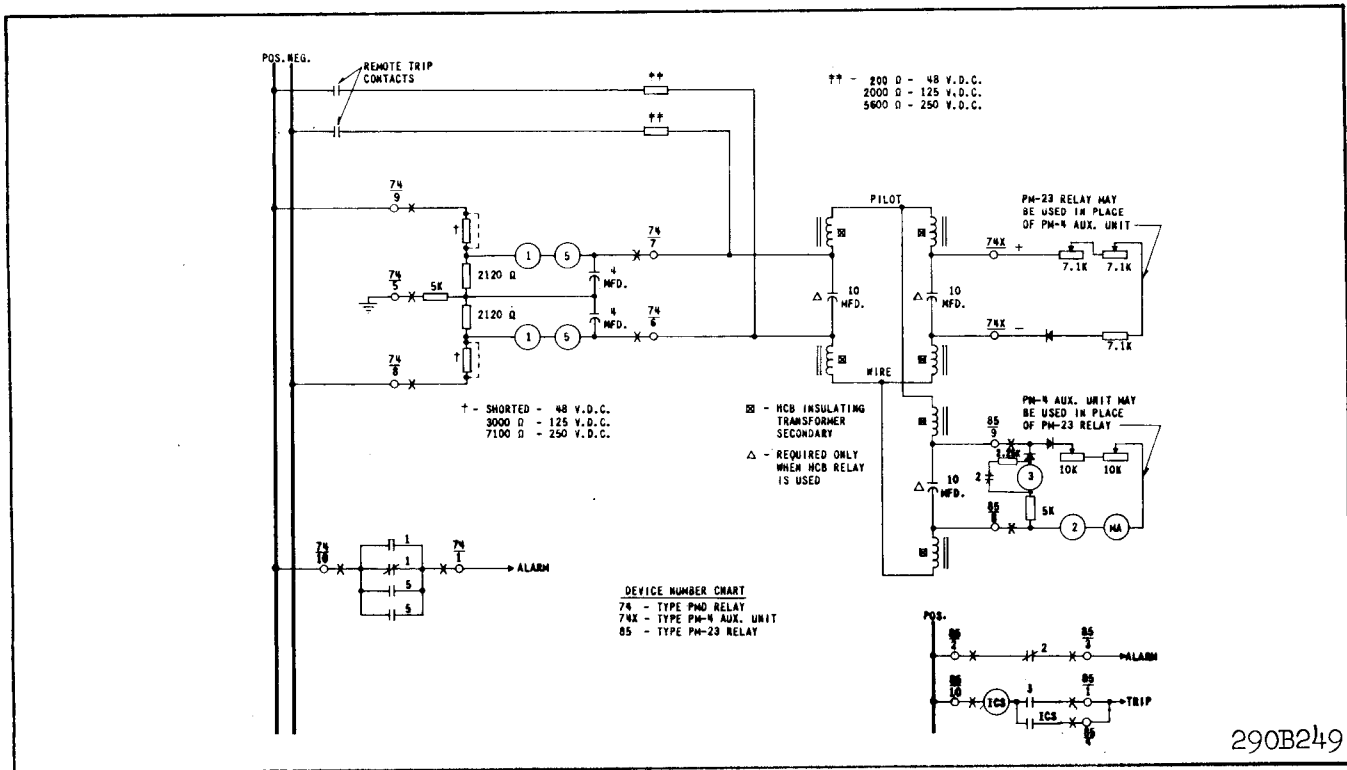

Fig. 24. External schematic of the type PMD relay with type PM-23 and PM-4 relays - Three terminal lines.

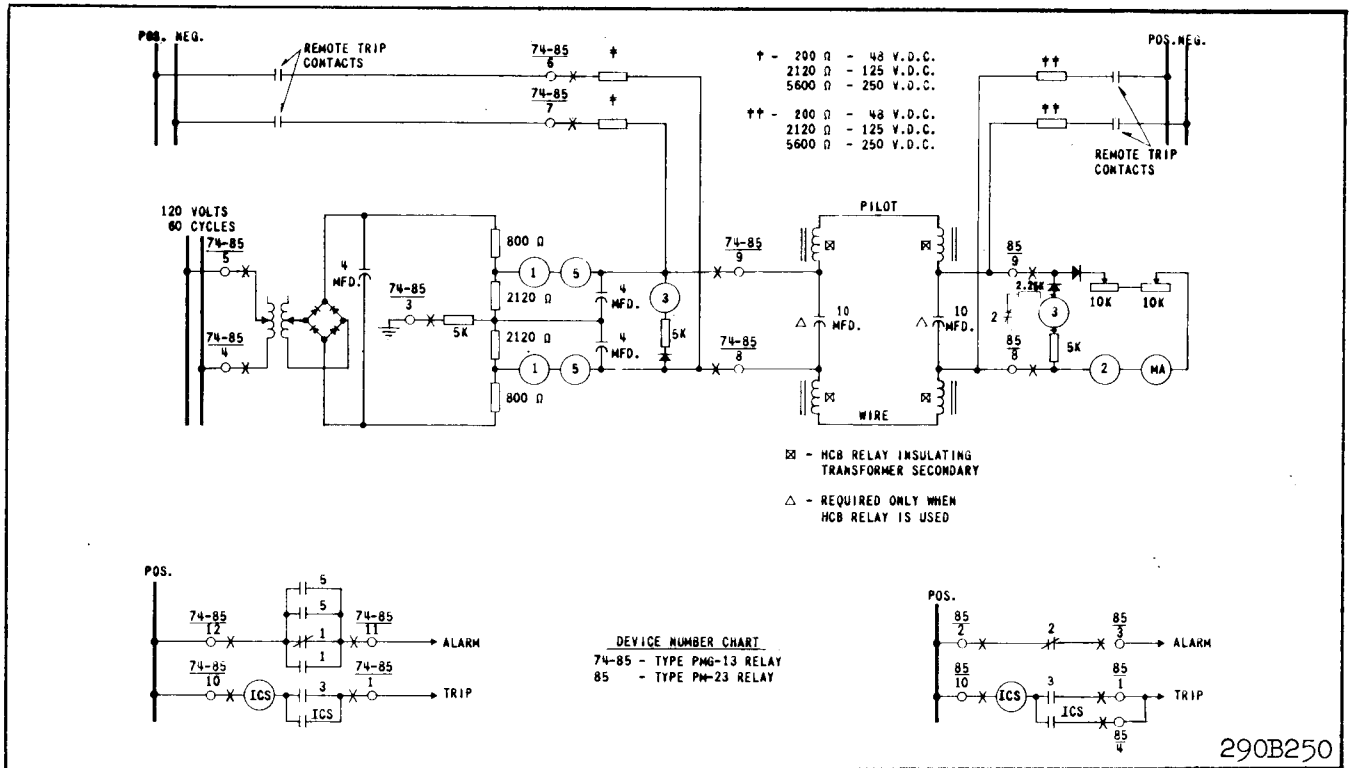

Fig. 25. External schematic of the AC type PMG-13 with type PM-23 relay - Two terminal lines.

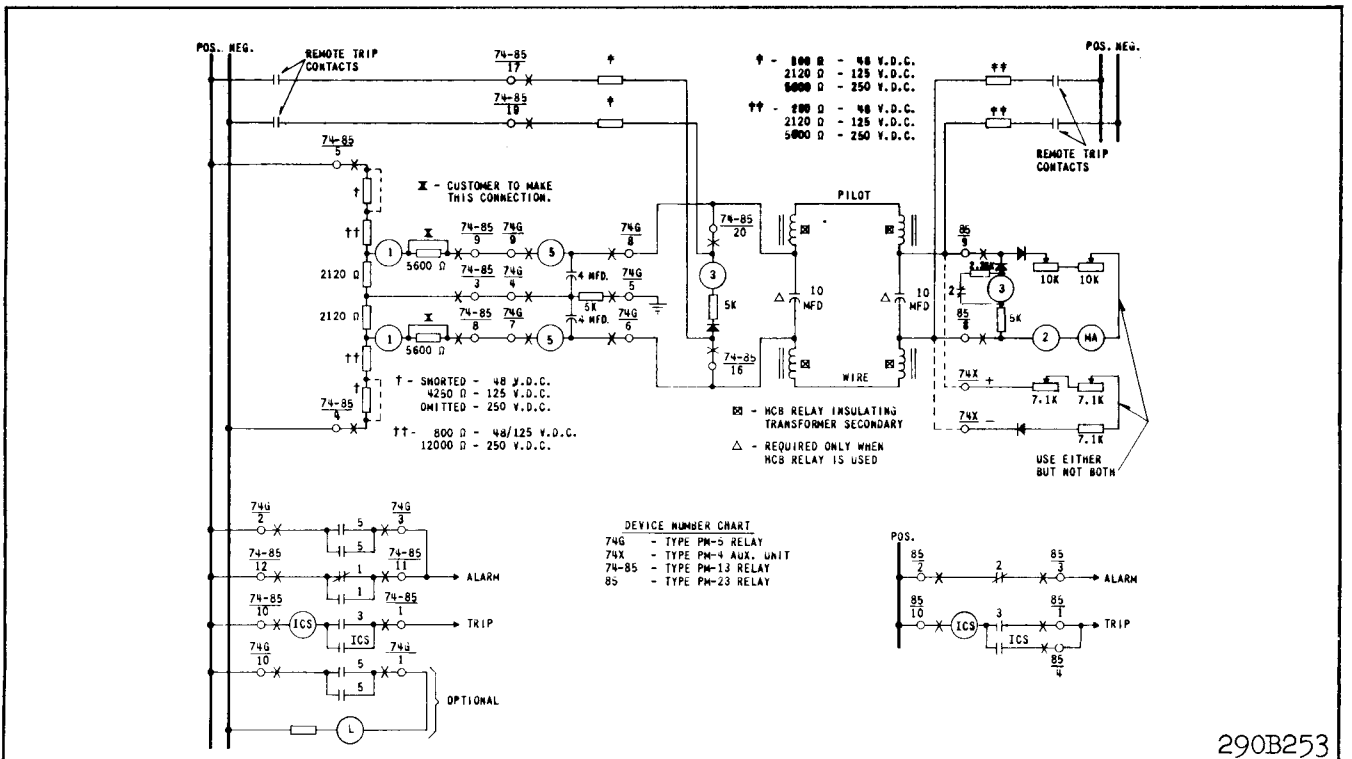

Fig. 26. External schematic of the DC type PM-13 and PM-5 relay with type PM-23 or PM-4 relay - Two terminal lines.

TYPE PM MONITORING RELAYS

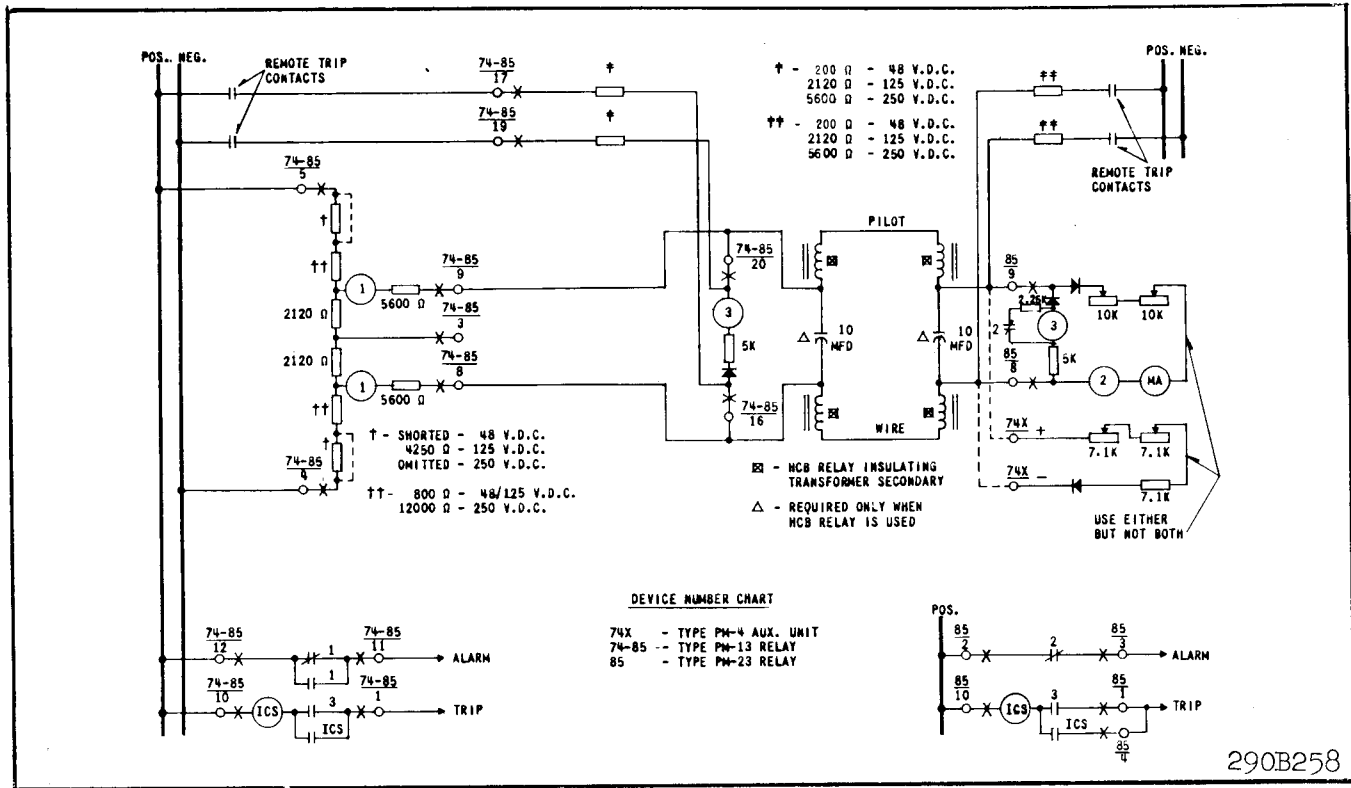
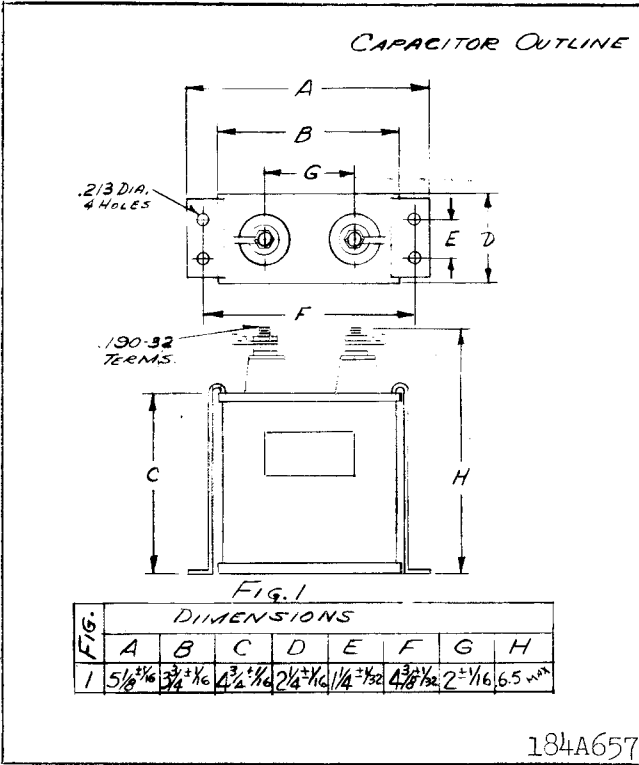

Fig. 27. External schematic of the DC type PM-13 relay with type PM-23 or PM-4 relay - Two terminal lines.



* Fig. 28. Outline and Drilling Plan for 10 mfd. capacitor – For reference only.

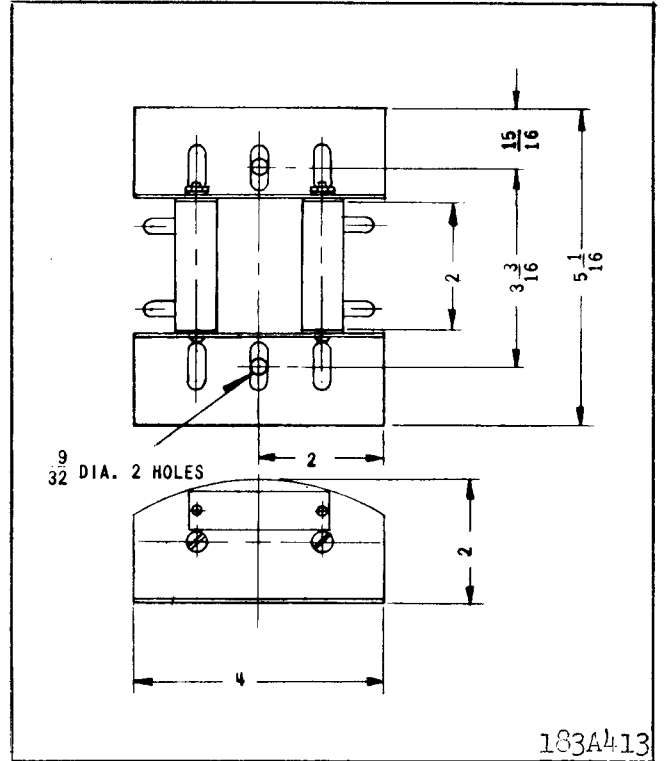

Fig. 29. Outline and Drilling Plan for External Remote trip Resistor Assembly.

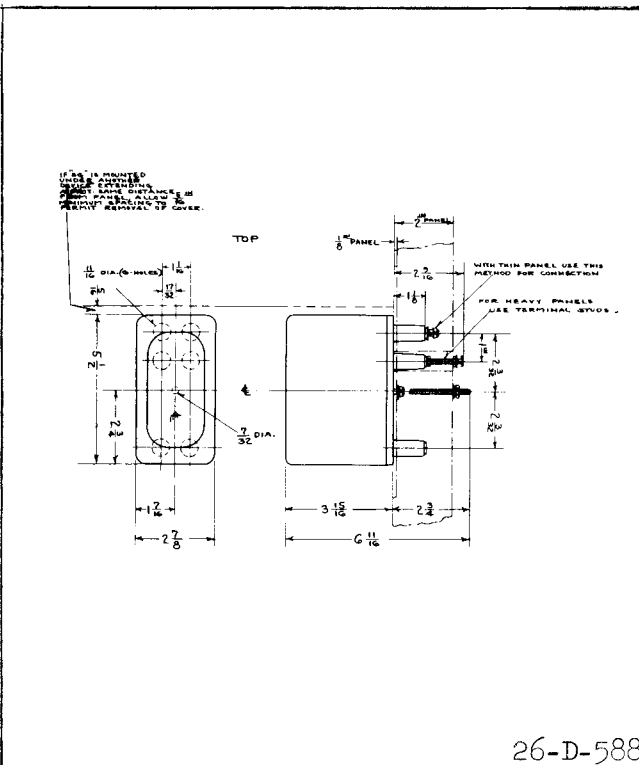

Fig. 30. Outline and Drilling Plan for the type PM-4 Auxiliary unit in the projection molded case.

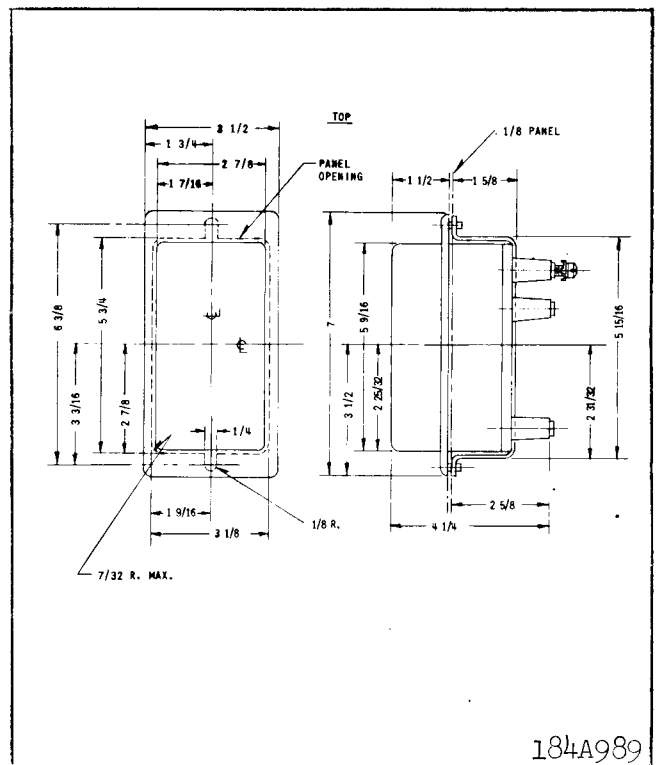
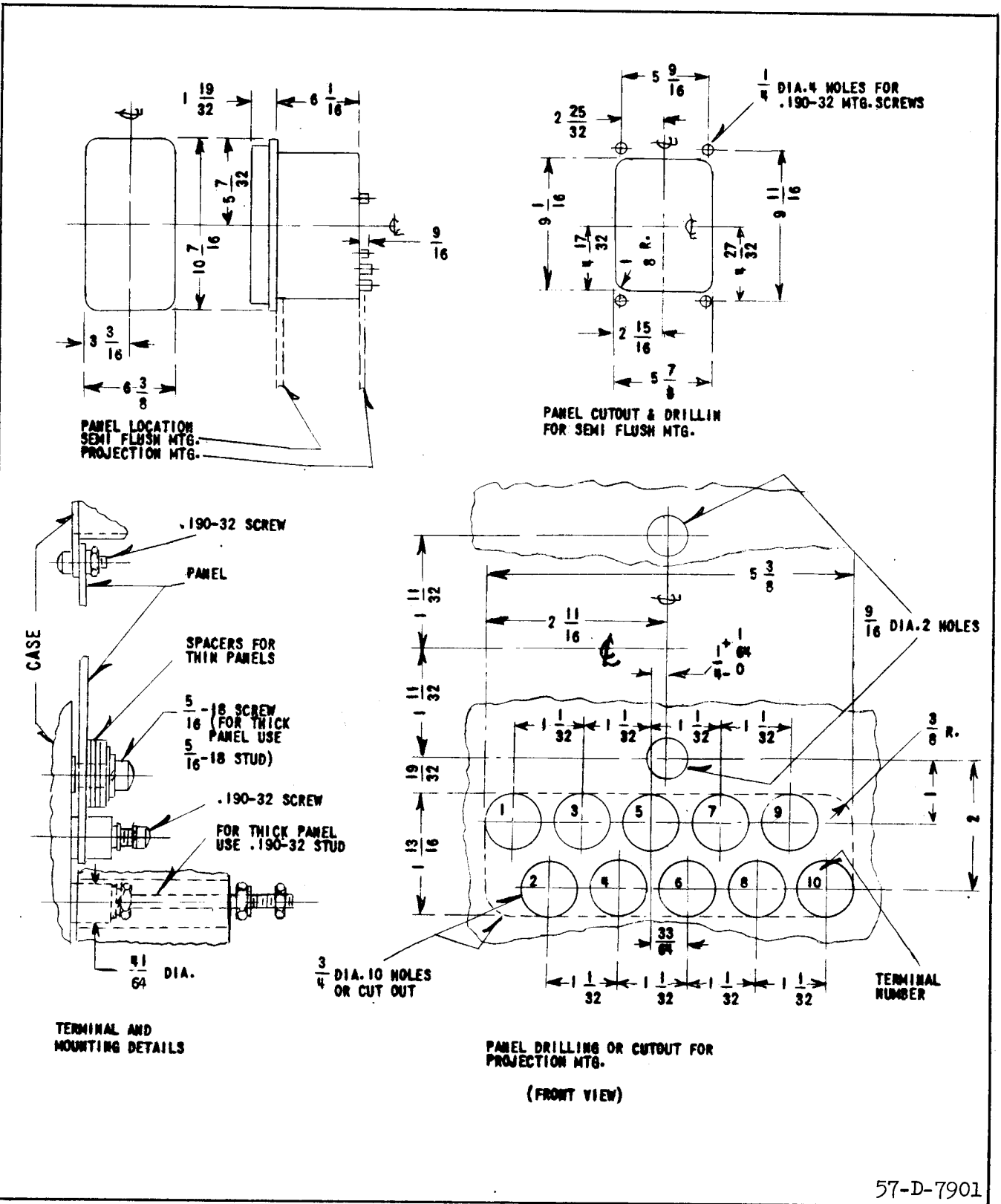

Fig. 31. Outline and Drilling Plan for the type PM-4 Auxiliary unit in the Semi-Flush molded case.



57-D-7901

Fig. 33. Outline and Drilling Plan for the type PM-2, PM-23, PMA-1 and PMD relays in the type FT 21 case.

TYPE PM MONITORING RELAYS

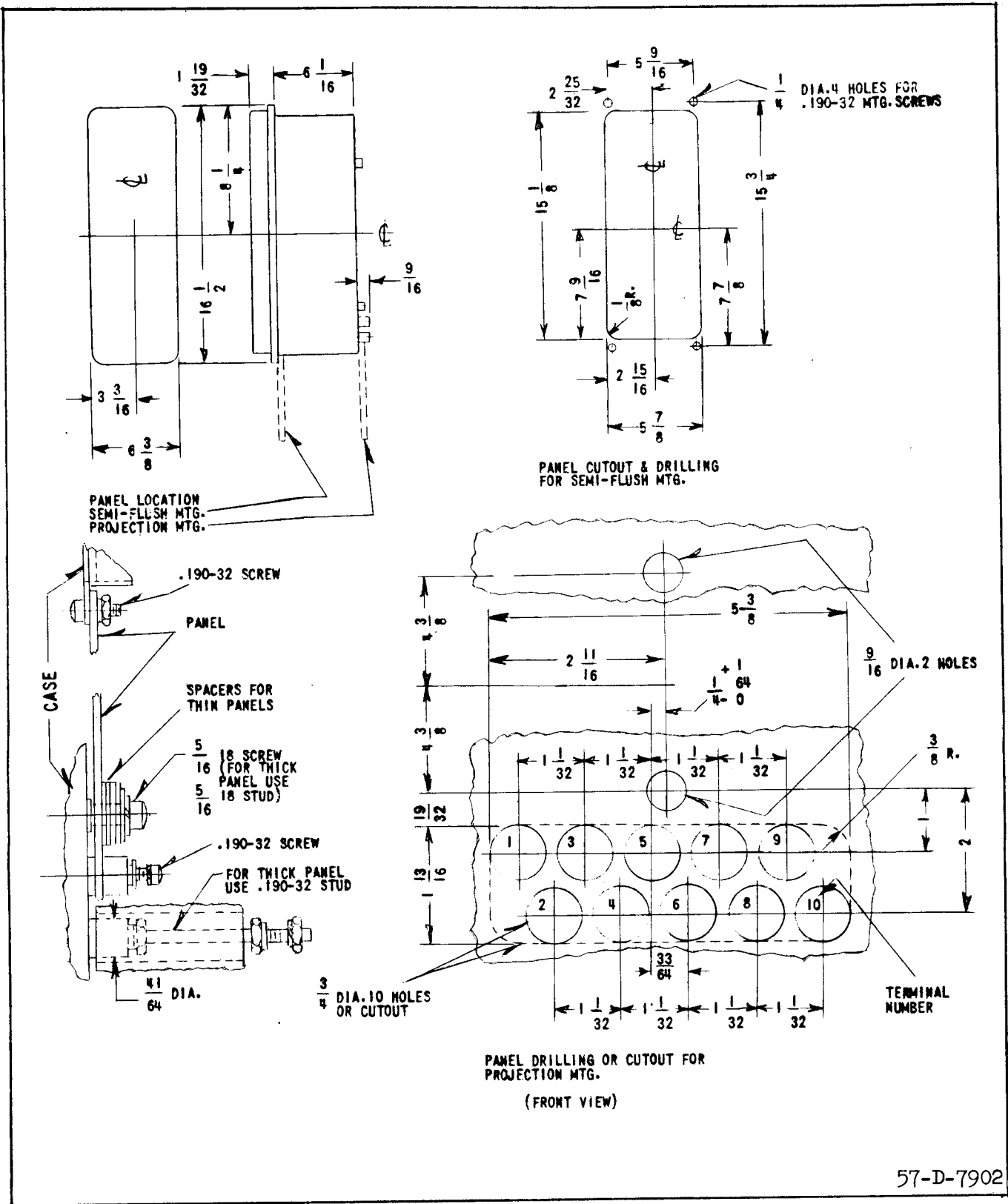

Fig. 34. Outline and Drilling Plan for the type PMA relay in the type FT 31 case.

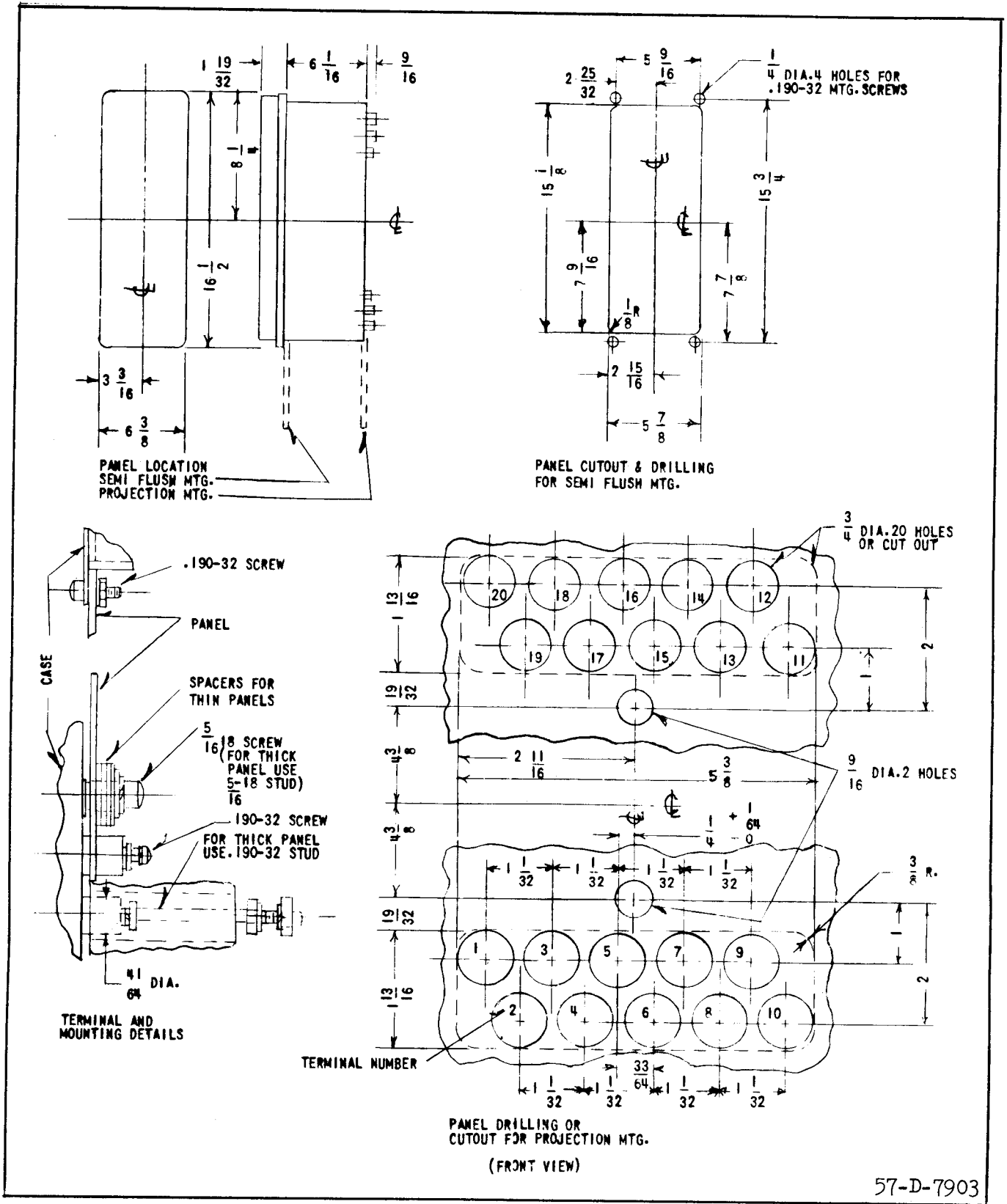
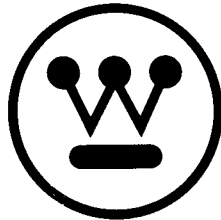

Fig. 35. Outline and Drilling Plan for the type PM-13 and PMG-13 relays in the type FT 32 case.



WESTINGHOUSE ELECTRIC CORPORATION
RELAY-INSTRUMENT DIVISION

NEWARK, N. J.

Printed in U.S.A.



INSTALLATION • OPERATION • MAINTENANCE INSTRUCTIONS

TYPE PM LINE OF RELAYS FOR PILOT-WIRE MONITORING AND TRANSFERRED TRIPPING

CAUTION Before putting protective relays into service, remove all blocking which may have been inserted for the purpose of securing parts during shipment, make sure that all moving parts operate freely, inspect the contacts to see that they are clean and close properly, and operate the relay to check the settings and electrical connections.

APPLICATION

Type PM Monitoring Relays provide continuous monitoring of a pilot-wire circuit to detect open circuits, short circuits, grounds, and wire reversal. In addition, transferred tripping can be effected where the PM-3, PM-13, PMG-13 or PM-23 relays are used. Table I illustrates the functions available with each relay. A 10 mfd. capacitor is supplied with each PM relay. This capacitor provides an a-c path between the two halves of the insulating transformer secondary windings as shown in Figs. 21 through 27.

Each circuit requires the following:

At one end to introduce monitoring current

One of the following:

For a-c Supply

For d-c Supply

PMA

PMD

PMA-1

PMD-1

PM-13 or PMG-13 (a.c.)

PM-13 or PMG-13 (d.c.)

At the other end to receive monitoring current (two-terminal line)

One PM-23 or PM-2 or PM-4

At the other ends to receive monitoring current (three-terminal line)

Two PM-23 or two PM-4 or two PM-2 or any combination of two of these relays.

CONSTRUCTION

PM relays consist of the following:

PMA

PMA-1

1-Polar Alarm Unit (1)

1-Polar Alarm Unit

1-Polar Ground Unit (5)
1-Tapped Transformer
1-Full-Wave Rectifier
3-4 mfd. Capacitors
1-Set of Potential
Dividing Resistors

PMD

1-Polar Alarm Unit (1)
1-Polar Ground Unit (5)
2-4 mfd. Capacitors
1-Set of Potential
Divider Resistors

PMG-13

1-Polar Alarm Unit (1)
1-Polar Ground Unit (5)
1-Polar Trip Unit (3)
1-Indicating Contactor
Switch
1-Set of Potential
Divider Resistors
1-Tapped Transformer
(A.C. Relay only)
1-Full-Wave Rectifier
(A.C. Relay only)
1-Blocking Rectifier
2-Remote Trip Resistors
3-4 mfd. Capacitors
(A-C Relay)
2-4 mfd. Capacitors
(D-C Relay)

PM-23

1-Polar Alarm Unit (2)
1-Polar Trip Unit (3)
1-Indicating Contactor
Switch (ICS)
1-Milliammeter, 5.0 ma.
1-Set of Adjustable and
Fixed Resistors
2-Blocking Rectifiers

1-Tapped Transformer
1-Full-Wave Rectifier
1-4 mfd. Capacitor
1-Set of Potential
Dividing Resistors

PMD-1

1-Polar Alarm Unit
1-Set of Potential
Divider Resistors

PM-13

1-Polar Alarm Unit (1)
1-Polar Trip Unit (3)
1-Indicating Contactors
Switch
1-Set of Potential
Divider Resistors
1-Tapped Transformer
(A.C. Relay only)
1-Full-Wave Rectifier
(A.C. Relay only)
1-Blocking Rectifier
2-Remote Trip Resistor
1-4 mfd. Capacitor

PM-2

1-Polar Alarm Unit (2)
1-Milliammeter, 5.0 ma.
1-Set of Adjustable
Resistors
1-Blocking Rectifier

TYPE PM MONITORING RELAYS

PM-3

- 1-Polar Trip Unit (3)
- 1-Resistor
- 1-Blocking Rectifier
- 1-Indicating Contactor Switch (ICS)

PM-4

- 1-Blocking Rectifier
- 1-Set of Adjustable & Fixed Resistors

PM-5

- 1-Polar Ground Unit (5)
- 2-4 mfd. Capacitors
- 1-Fixed Resistor

TABLE I

FUNCTION	PMA & PMD	PMA-1 & PMD-1	PM-13	PMG-13	PM-23	PM-2	PM-3	PM-4	PM-5
Monitoring Current Source	X	X	X	X					
Receives Monitoring Current					X	X		X	
Trouble Alarm	X	X	X	X	X	X			X
Transmits Trip Signal	X †	X †	X	X	X †	X †	X †	X †	
Receives Trip Signal			X	X	X		X		
Sensitive Ground Detection	X			X					X
Measures Monitoring Current					X	X			

† With External Resistors

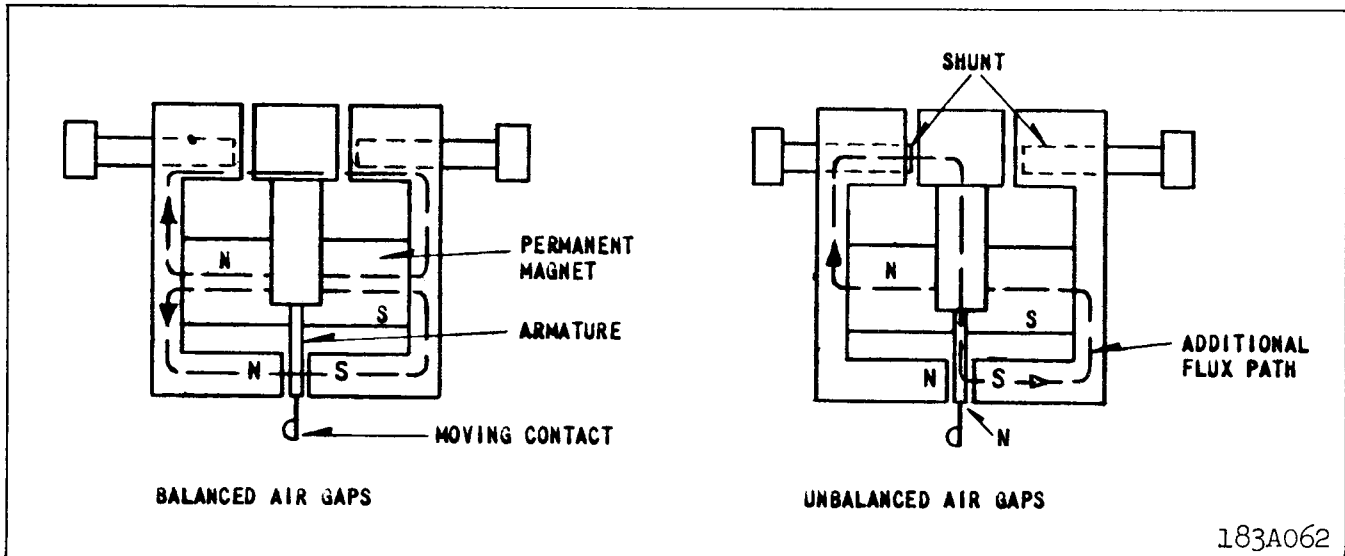

Fig. 1. Polar Unit Permanent Magnet Flux Paths.

Polar Unit

The polar unit consists of a rectangular shaped magnetic frame, an electromagnet, a permanent magnet, and an armature. The poles of the crescent shaped permanent magnet bridge the magnet frame. The magnetic frame consists of three pieces joined in the rear with two brass rods and silver solder. These non-magnetic joints represent air gaps, which are bridged by two adjustable magnetic shunts. The winding or windings are wound around a magnetic core. The armature is fastened to this core and is free to move in the front air gap. The moving contact is connected to the free end of a leaf spring, which, in turn, is fastened to the armature.

Indicating Contactor Switch

The d-c indicating contactor switch is a small clapper type device. A magnetic armature, to which leaf-spring mounted contacts are attached, is attracted to the magnetic core upon energization of the switch. When the switch closes, the moving contacts bridge two stationary contacts, completing the trip circuit. Also during this operation two fingers on the armature deflect a spring located on the front of the switch, which allows the operation indicator target to drop. The target is reset from the outside of the case by a push rod located at the bottom of the cover.

The front spring, in addition to holding the target, provides restraint for the armature and thus controls the pickup value of the switch.

OPERATION

Pilot Wire Monitoring

Monitoring current is introduced into the pilot wire as shown in the external schematics, figures 21 to 27, by the monitoring current source. External schematics showing other combinations are available on request. A nominal 20 volts is impressed across the 10 mfd. capacitor at the left-hand line terminal in Figures 21 to 27. This voltage produces a current circulating through one winding of the HCB insulating transformer, one pilot wire, the PM-23, PM-2, or PM-4, and back through the other pilot wire and the other winding of HCB insulating transformer.

Adjustment of the resistors of the PM-23, PM-2 or PM-4 relay at the other end of the pilot wire provides a normal one-milliamper d-c circulating current. In the case of three-terminal lines, the monitoring source relay output current is 2 ma. in order to pro-

vide each receiving end relay with 1 ma. The alarm unit of the monitoring current source relay is adjusted to float between the high and low current contacts with normal monitoring current. The PM-23, receiving-end alarm relay, is adjusted to float between the low-current alarm contact and a contact stop with 1 ma. flowing.

Short Circuits

A complete or partial short circuit on the pilot wires increases the current in the current-source relay, causing the high-current alarm contacts to close. The resulting current decrease in the PM-23 relay closes the alarm contact. Short circuits of 5000 ohms or less will be detected.

Open Circuits

Current decreases to zero in all relays. Low-current alarm contact of the current source relay closes. Alarm contact of PM-23 relay closes.

Reversed Wires

On applications using the PM-23 relay, current increases in the sending end relay to close the high-current alarm contacts. Current drops to zero in the PM-23 relay monitoring coil to close the low-current alarm contacts.

If the pilot wire should be opened and reclosed with reversed connections when the PM-23 relay is in service, the alarm contact (2) in the PM-23 drops out. The alarm contact dropping out shunts the trip unit coil (3), and prevents the trip unit contact (3) from operating momentarily. The trip unit contact is prevented from operating because the capacitor at the sending end discharges through the pilot wire and the trip unit (3) circuit. This will have no effect on remote trip operation.

The current decreases in both sending and receiving end relays when the PM-2, or PM-4 relays are used. Low current alarm contacts close.

* Grounds

The voltage-divider circuit of the PMA, PMD, and PMG-13 source relays has its midpoint grounded through a current-limiting resistor. Thus, a pilot-wire ground will cause an increase in current in one coil circuit, and a decrease in the other one. This unbalance in the current flowing through the two windings (5) of the ground alarm relay unit will cause it to close one of its contacts (depending on which pilot wire is grounded) to give an alarm. Grounds of 10,000 ohms or less will be detected.

TYPE PM MONITORING RELAYS

For adding the sensitive ground detection where PMA-1, PMD-1, or PM-13 relays have been installed, the PM-5 relay can be added to the circuitry, as shown in figure 24. This relay also has a 10,000-ohm ground sensitivity.

Transferred Tripping

Breakers located at the PMG-13 or PM-13 and PM-3 or PM-23 stations can be tripped by the application of a d-c voltage to the pilot wires at remote locations, as shown in figures 21 to 27. Transferred tripping can be effected from any location by applying 48 volts d-c (through dropping resistors when required) to the pilot wire with polarity opposite to that of the monitoring voltage. When tripping the PM-23, the current is increased above 2.0 ma, in reverse direction, to close the trip contact. When tripping the PMG-13 or PM-13, the reversed d.c. voltage operates the trip unit (3).

See Tables II and III for tripping resistor values. Nominal tripping currents is 5ma. at all rated voltages.

Polar Unit

Polar unit flux paths are shown in figure 1. With balanced air gaps, permanent magnet flux flows in two paths, one through the front, and one through the rear gaps. This flux produces north and south poles, as shown. By turning the left shunt in, some of the flux is forced through the armature, making it a north pole. Thus, reducing the left hand rear gap will produce a force tending to pull the armature to the right. Similarly, reducing the right hand gap will make the armature a south pole and produce a force tending to pull the armature to the left.

The alarm unit contacts of the sending and receiving end relays are biased to move to the left when the relay is deenergized. The PMG-13 or PM-13 and PM-23 trip unit contact is biased to move to the left when the relay is deenergized. The PM-5 is adjusted so that the moving contact floats when the relay is deenergized.

CHARACTERISTICS

Nominal Calibration Values

Nominal current values to close contacts are listed in Tables IV and V.

Voltage Ratings

Supply voltage ratings of the monitoring source

relays to obtain continuous monitoring current are as follows:

DC - 48, 125, and 250 volts
AC - 120 volts, 60 cycles (Primary taps 100, 110, 120 & 130)
Voltage impressed on the pilot wire is a nominal 20 volts for monitoring, and 48 volts for tripping.
Supply voltage ratings to obtain remote tripping are: 48, 125, and 250 volts d-c.

Coil Resistance (each winding)

Alarm coil (1)	
two terminal line	1050-1250 ohms
three terminal line	700-900 ohms
Alarm coil (2)	2200-2600 ohms
Trip coil (3)	1800-2200 ohms
Ground Alarm coil (5)	5200-5800 ohms

PM-4 and PM-23 Resistance

Nominal PM-4 and PM-23 total resistance when adjusted for service is 20,000 ohms less pilot wire loop resistance at 1 ma.

PMA, PMA-1 and AC PMG-13, PM-13 Burden

0.5 VA at tap voltage	-	2-terminal line relay
1.0 VA at tap voltage	-	3-terminal line relay

Rectifiers

Approximate forward resistance - 560 ohms at 1 ma
300 ohms at 2 ma

Rating

Continuous forward
current - amperes - 1

Continuous back
voltage - rms volts - 200

Remote Tripping

Remote trip resistors are listed in Table II and III for 48, 125, and 250 volts d-c.

The relays have sufficient thermal capacity to withstand 20 MA d-c continuously when remote tripping. Nominal trip currents in the tripping relays are 5.0 MA d-c with 48, 125, and 250 volts d-c supply and a 2000-ohm pilot wire.

TABLE II

PMA, PMA-1, PMD, AND PMD-1 APPLICATIONS
EXTERNAL RESISTORS FOR D.C. REMOTE TRIPPING
(2 REQUIRED PER STATION)

# LINE TERMINALS	D.C. VOLTAGE	STATION A PMA or PMA-1	STATION A PMD or PMD-1	STATION B PM-2 & PM-3 or PM-23 or PM-4	STATION C PM-2 & PM-3 or PM-23 or PM-4	TO OPERATE
2	48	200	200	—	—	PM-23 or PM-3
	125	3550	3550	—	—	"
	250	9300	9300	—	—	"
3	48	200	200	—	—	"
	125	2000	2000	—	—	"
	250	5600	5600	—	—	"

TABLE IIIA

PMG-13 AND PM-13 (D.C. SUPPLY) APPLICATIONS
RESISTORS FOR D.C. REMOTE TRIPPING
(2 REQUIRED PER STATION)

# LINE TERMINALS	D.C. VOLTAGE	STATION A PMG-13 or PM-13	STATION B PM-2 & PM-3 or PM-23 or PM-4	STATION C PM-2 & PM-3 or PM-23 or PM-4	TO OPERATE
2	48	200 †	200	—	PMG-13 or PM-13 and PM-23 or PM-3
	125	2120 †	2120	—	"
	250	5600 †	5600	—	"
3	48	200 †	200	200	"
	125	1500 †	1500	1500	"
	250	4000 †	4000	4000	"

† Mounted in Relay

TABLE IIIB

PMG-13 AND PM-13 (A.C. SUPPLY) APPLICATIONS
(2 REQUIRED PER STATION)
RESISTORS FOR D.C. REMOTE TRIPPING

# LINE TERMINALS	D.C. VOLTAGE	STATION A PMG-13 or PM-13	STATION B PM-2 & PM-3 or PM-23 or PM-4	STATION C PM-2 & PM-3 or PM-23 or PM-4	TO OPERATE
2	48	200 †	200	—	PMG-13 or PM-13 and PM-23 or PM-3
	125	2120 †	2120	—	"
	250	5600 †	5600	—	"
3	48	200 †	200	200	"
	125	1500 †	1500	1500	"
	250	4000 †	4000	4000	"

† Mounted in Relay

TABLE IV

NOMINAL CALIBRATION VALUES – TWO TERMINAL LINES

<u>RELAY</u>	<u>LOW CURRENT ALARM</u> ¹	<u>HIGH CURRENT ALARM</u> ²	<u>TRIP</u>
PMA or PMA-1	0.7 ma	1.3 ma	–
PMD or PMD-1	0.7	1.3	–
PM-5 †	–	±0.3	–
PMG-13 or PM-13	0.7 ††	1.3 ††	14 V.
PM-23 or PM-2 & PM-3 †	0.7	–	14 V.

† Same relay as for three-terminal lines

†† These are pilot-wire current values

1 – Left-hand contacts, front view.

2 – Right-hand contacts, front view.

TABLE V

NOMINAL CALIBRATION VALUES – THREE TERMINAL LINES

<u>RELAY</u>	<u>LOW CURRENT ALARM</u>	<u>HIGH CURRENT ALARM</u>	<u>TRIP</u>
PMA or PMA-1	1.7 ma	2.3 ma	–
PMD or PMD-1	1.7	2.3	–
PM-5 †	–	±0.3	–
PMG-13 or PM-13	1.7 ††	2.3 ††	14 V.
PM-23 or PM-2 & PM-3 †	0.7	–	14 V.

† Same relay as for two-terminal lines

†† These are pilot-wire current values

Trip Circuit

The main contacts will safely close 30 amperes at 250 volts d-c and the seal-in contacts of the indicating contactor switch will safely carry this current long enough to trip a circuit breaker.

The indicating contactor switch has two taps that provide a pickup setting of 0.2 or 2 amperes. To change taps requires connecting the lead located in front of the tap block to the desired setting by means of a screw connection.

Trip Circuit Constant

Indicating Contactor Switch (ICS)

0.2 ampere tap 6.5 ohms d-c resistance

2.0 ampere tap 0.15 ohms d-c resistance

SETTING THE RELAY

Operating units of all relays are adjusted in the factory to the values listed in Tables IV and V to a tolerance of ±5%. No settings are required on these units.

For all 48/125-volt d.c. relays, connect jumpers across resistors as shown on the internal schematics.

PM-4, PM-2, and PM-23 Relays

Adjust the resistors in the PM-4, PM-2, or PM-23 relay or relays to a value of 1 MA d-c with the monitoring circuits connected for service. Use the milliammeter in the PM-23 for this purpose or use a portable milliammeter with a resistance of less than 200 ohms. Where it is not practical on three-terminal lines to adjust both receiving relays simultaneously, set one receiving relay for 18,000 ohms total resistance (including relay coil and resistors) by measurement prior to final adjustment of the other receiving relay. This procedure will minimize the change in monitoring current in the first relay to be adjusted when making the final adjustment of the second relay.

PMA, PMA-1, PMG-13 and PM-13 Relays

Select the transformer tap nearest to expected normal a-c supply voltage. The full wave rectifier is

connected to a secondary transformer tap. Where desired, the output voltage can be raised about 5% by reconnecting across the full secondary winding.

Indicating Contactor Switch

No setting is required on the ICS unit except the selection of the 0.2 or 2.0 ampere tap setting. This selection is made by connecting the lead located in front of the tap block to the desired setting by means of the connecting screw. When the relay energizes a type WL relay switch, or equivalent, use the 0.2 ampere tap.

INSTALLATION

The relays should be mounted on switchboard panels or their equivalent in a location free from dirt, moisture, excessive vibration, and heat. Mount the relay vertically by means of the four mounting holes on the flange for semi-flush mounting or by means of the rear mounting stud or studs for projection mounting. Either a mounting stud or the mounting screws may be utilized for grounding the relay. The electrical connections may be made directly to the terminals by means of screws for steel panel mounting or to the terminal studs furnished with the relay for thick panel mounting. The terminal studs may be easily removed or inserted by locking two nuts on the stud and then turning the proper nut with a wrench.

For detailed FT case information, refer to I.L. 41-076.

Where the potential to ground impressed on the relays can exceed 700 volts, a drainage reactor in conjunction with a KX-642 tube, or the reactor in conjunction with 700 volt carbon-block arresters, is recommended. For details, see Protection of Pilot-Wire Circuits, AIEE Committee Report, paper 58-1190, AIEE Transactions, 1959, Volume 78, Part III B pp. 205-212. Also, see AIEE Special Publication S-117, Applications and Protection of Pilot-Wire Circuits for Protective Relaying, July 1960.

ADJUSTMENTS AND MAINTENANCE

The proper adjustments to insure correct operation of this relay have been made at the factory and should not be disturbed after receipt by the customer. If the adjustments have been changed, the relay taken apart for repairs, or if it is desired to check the adjustments at regular maintenance periods, the instructions in the succeeding sections should be followed.

Acceptance Tests

The following tests are recommended when the relay is received from the factory. If the relay does not perform as specified below, the relay either is not properly calibrated or it contains a defect.

Indicating Contactor Switch (ICS)

Close the contact of the tripping unit and pass sufficient direct current through the trip circuit to close the contacts of the ICS unit. This value of current should not be greater than the particular ICS tap setting being used (0.2 or 2.0). The indicator target should drop freely.

PMA and PMA-1 Relays

Alarm Unit (1)

Set the primary tap on 120 volts. Connect a variable resistor of approximately 20,000 ohms in series with a low-range d-c milliammeter across terminals 6 and 7 with the instrument positive connected to terminal 7. Apply 120 volts at rated frequency to terminals 4 and 5. Adjust the 20,000-ohm resistor to obtain a current of one ma. d.c. For a three-terminal line relay, use a 10,000-ohm resistor and set the current to 2 ma. d.c. At this value, the moving contact of the alarm or monitoring relay unit (1) should float between the two sets of stationary contacts. In the PMA relay, the ground alarm unit (5) contact should also float. (This contact will also float when the relay is de-energized.) Increase and decrease the one or two-milliampere monitoring current to check the calibration values listed in Tables IV and V.

Ground Unit (5)

Reconnect the 20,000-ohm resistor. For the PMA relay only, short terminals 7 and 3. The contact of the ground alarm unit (5) should close to the right when the relay is energized. Remove the short, and connect it between terminals 6 and 3. The ground alarm unit (5) should close to the left. The action of the monitoring unit (1) contact is of no significance in this simulated pilot-wire ground test. To check the pickup current of the ground detector, first remove the 20,000-ohm resistor from terminals 6 and 7. Connect a 0-1 d.c. milliammeter in series with a variable resistor of about 50,000 ohms between terminals 3 and 6. The ground unit should close its left-hand contact at approximately 0.3 ma. d.c. With the milliammeter and resistor connected between terminals 3 and 7, the right-hand contact should close at 0.3 ma. d.c.

TYPE PM MONITORING RELAYS

PMD and PMD-1 Relays

Alarm and Ground Units

Connect an adjustable 20,000-ohm resistor (or 10,000-ohms for a 3-terminal relay) in series with a d-c milliammeter across terminals 6 and 7 with the instrument positive connected to terminal 7. Apply rated d-c voltage to terminals 8 and 9 with positive on terminal 9. Now check the PMD and PMD-1 relays, following the procedure given in the previous section for the PMA and PMA-1 relays, respectively. Note, however, that terminal 5 of the PMD relay corresponds to terminal 3 of the PMA relay.

PM-2, PM-3, and PM-23 Relays

Alarm Unit (2)

Apply a variable d-c voltage of approximately 20 volts to relay terminals 8 and 9 (terminal 9 positive) of the PM-2 or PM-23 relay. Adjust the voltage to obtain a reading of one ma. on the relay milliammeter. The monitoring polar unit (2) contacts should float. Reduce the current gradually. The monitoring alarm contacts should close at 0.7 ma. d.c. The tripping unit (3) of the PM-23 relay should not move during this test. The milliammeter has been adjusted to read 1 ma. $\pm 5\%$. As a result the pointer may not read zero for a zero current condition.

Tripping Unit (3)

To check the PM-3 relay or the tripping unit of the PM-23 relay, apply the variable d-c voltage in series with an external milliammeter to relay terminals 8 and 9 with terminal 8 positive for the PM-23 relay, or terminal 9 positive for the PM-3 relay. When checking the pickup of the PM-23 trip unit block open the alarm unit contacts (2) so as to remove the shunt resistor from around the trip coil (3).

The tripping relay unit (3) should pick up with positive action at 14 volts d.c. and should drop out at approximately 10 volts. The alarm unit of the PM-23 relay will not operate during this test.

PM-4 Relay

This device is simply a set of resistors and a diode to connect into the pilot-wire circuit to provide a path for the monitoring current. The resistors can be checked with an ohmmeter, and the diode can be checked either with an ohmmeter, or as explained in the section entitled "Rectifier Check" under "Routine Maintenance". If an ohmmeter is used, the difference in forward and reverse resistance readings obtained will be dependent on the current flowing through the diode.

PM-5 Relay

Apply 5 volts d.c. in series with a 0-1 d.c. milliammeter and a 20,000-ohm variable resistor to terminals 6 and 7 with positive on terminal 6. The left-hand contact should close at approximately 0.3 ma. Now apply the same circuit to terminals 8 and 9 with positive on terminal 9. The right-hand contact should close at approximately 0.3 ma.

PM 13 Relays - A.C. and D.C.

Alarm Unit (1)

Connect a variable 20,000-ohm resistor (10,000 ohms for a 3-terminal-line relay) in series with a d-c milliammeter across terminals 8 and 9 with the instrument positive on terminal 9. For the a-c relay, set the primary tap on 120 volts. Now apply the rated supply voltage to terminals 4 and 5. This will be 48, 125, or 250 volts d.c., or 120 volts a.c. as indicated on the relay nameplate. Adjust the variable resistor to obtain a current of one ma. for a 2-terminal line relay, or 2 ma. for a 3-terminal relay. At this value, the moving contacts of the alarm or monitoring (1) relay unit (the upper polar unit) should float between the two sets of stationary contacts. Increase and decrease the one or 2 ma. monitoring current to check the calibration values listed in Tables IV and V.

Tripping Unit (3)

To check the operation of the tripping unit 3 (the lower polar unit), apply a d.c. potential across terminals 16 (positive) and 20 (negative). The tripping polar unit should pick up at 14 volts, and should drop out at approximately 10 volts. The resistance of the series dropping resistors for transferred tripping (listed in Tables III A and III B) can be checked with an ohmmeter. The circuit location of these resistors can readily be seen from the external schematic, Figure 27.

PMG-13 Relays - A.C. and D.C.

Alarm and Tripping Units

Follow the procedure given in the previous section for the a-c. and d-c. PM-13 relays.

Ground Unit (5)

Connect the 20,000-ohm (or 10,000-ohm) resistor and milliammeter across terminals 8 and 9. With rated voltage applied and one ma. (or 2 ma.) flowing, successively short circuit terminals 3 and 8, then 3 and 9. The ground alarm unit 5 (lower polar unit) should move first to the left, then to the right. To check the pickup current of the ground detector, first remove the 20,000-ohm resistor from terminals 8 and 9. Connect a 0-1 d.c. milliammeter in series

with a variable resistor of about 50,000 ohms between terminals 3 and 8. The left-hand contact should close at approximately 0.3 ma. d.c. With the milliammeter resistor connected, between terminals 3 and 9, the right-hand contact should close at 0.3 ma. d.c. The external schematic diagrams for these relays are shown in Figure 23 and 25.

Routine Maintenance

CAUTION - Do not make any performance check, calibration tests, or adjustments while the PM relays are energized or connected to the pilot wires, to prevent the possibility of inadvertently causing a break operation. The PM relays may be removed from service for testing, without jeopardizing HCB relay protection, providing that the connections between the 10-mfd capacitor and the HCB insulating transformer are not disturbed.

Contacts

All contacts should be periodically cleaned. A contact burnisher S#182A836H01 is recommended for this purpose. The use of abrasive material for cleaning contacts is not recommended because of the danger of embedding small particles in the face of the soft silver and thus impairing the contact.

Operational Check

In addition to cleaning contacts, it is recommended that an operational check be performed periodically by opening and short-circuiting the pilot wires, as well as grounding them at the relay terminals. Note: These pilot-wire faults should not be applied directly to the pilot wires when the HCB relays are in service. It is also recommended that the trip circuits of the PM relays be opened (where tripping is used), to prevent the possibility of inadvertently tripping the associated circuit breaker during testing. If the relays do not perform as expected, and diode failure is suspected, the diode tests described in the following section may be performed.

Rectifier (Diode) Check

If there is suspicion of a rectifier (diode) failure, apply 30 volts d.c. reverse voltage (positive on arrowhead) through a 300-ohm resistance to the diode. Measure the voltage across the diode. If this voltage is not essentially 30 volts, the diode is short-circuited. Now apply 30 volts d.c. in the forward direction through the 300-ohm resistor, and measure the voltage across the resistor. If the voltage is not essentially 30 volts, the diode may have a high forward resistance. If the voltage is zero, the diode is open-circuited.

Calibration

If the relay has been dismantled or the calibration has been disturbed, use the following procedure for calibration.

With the permanent magnet removed, see that the moving armature floats in the central area of the air-gap between the poles of the polar unit frame. If necessary, loosen the core screw in the center rear of the unit and shift the core and contact assembly until the armature floats. (This can best be done with the polar unit removed from the relay.) Then retighten the core screw and replace the permanent magnet with the dimple (north pole) on the magnet to the left when viewed from the front.

Polar Units-General

The following mechanical adjustments are given as a guide, and some deviation from them may be necessary to obtain proper electrical calibration.

Magnetic Shunt Adjustment

The sensitivity of the polar unit is adjusted by means of two magnetic, screw-type shunts at the rear of the unit, as shown in Fig. 1. These shunt screws are held in proper adjustment by a flat strip spring across the back of the polar unit frame, so no locking screws are required. Looking at the relay, front view turning out the right-hand shunt to open the right-hand air gap decreases the amount of current required to close the right-hand contact. Conversely, drawing out the left-hand shunt increases the amount of current required to close the right-hand contact, or decreases the amount of current required to close the left-hand contact (with the proper direction of current flow). Also, if a relay trips to the right at the proper current, the dropout current can be raised by turning in the right-hand shunt. The two shunt-screw adjustments are not independent, however, and a certain amount of trimming adjustment of both shunt screws is generally necessary to obtain the desired pickup and dropout calibration.

In general, the farther out the two shunt screws are turned, the greater the toggle action will be, and as a result, the lower the dropout current. For the tripping units (3) of the PM-3, PM-13, and PM-23 relays, toggle action is desirable, with a dropout current around 75 percent of the pickup current. For the monitoring alarm relay units, toggle action is not desired. Instead, the armature is adjusted to float between the pole faces at a given current (1 or 2

TYPE PM MONITORING RELAYS

The following chart indicates the units present in each relay.

FUNCTION AND UNIT	PMA PMD	PMA-1 PMD-1	PM2	PM3	PM4	PM5	PM13	PMG13	PM23
Alarm for p.w. open, short or reversal (1) (2)	X	X	X				X	X	X
Transfer - Trip Unit (3)				X			X	X	X
Alarm for p.w. ground (5)	X					X		X	
D.C. Path for Monitoring Current					X				

ma.), and to move gradually toward the high or low-current alarm as the coil current is increased or decreased. Similarly, the floating adjustment of the armature of the ground alarm unit (5) requires that both shunt screws be turned in relatively far. Then the armature will move gradually to the left or right as the current through the two #5 coils is unbalanced.

The electrical calibration of the polar unit is also affected by the contact adjustment as this changes the position of the polar unit armature. Do not change the contact adjustment without rechecking the electrical calibration.

Contact Adjustment - All Relays

For all monitoring alarm units, designated (1) or (2), turn in all the stationary contact and contact stop screws until they just touch the moving contact. Advance the screws to hold the armature in the central portion of the magnetic air gap between the two pole faces. (The stationary contact screws have a round silver contact face; the stop screws do not have this silver facing.) Now back off all the contact and contact stop screws one full turn. This will give a total contact travel of 0.050 inch. When the relay is properly calibrated, some touch-up adjustment may be necessary so that double contacts will both close at the same current value. The contact gap between the floating moving contact and the right-hand or left-hand stationary contacts or contact stops will be approximately 0.025 inch when the relay is in operation.

For the tripping (3) units of the PM-3, PM-13, PMG-13, and PM-23 relays, adjust the contacts as described in the previous paragraph, except back off the contact and stop screws one-half turn each to

give a total moving contact travel of approximately 0.025 inch. In operation of the tripping unit, the moving contact will normally rest against the contact stop screws, and will pick up only for a transferred-tripping operation.

For the pilot-wire ground alarm unit (5) of the PMA, PMD, PM5, and PMG-13 relays, follow the same general procedure except back off both stationary contact screws two turns each. This will give a contact gap of 0.050 on each side of the moving contact when it is its normal central position.

Electrical Calibration - All Relays

In the following sections, the calibration instructions are given for the polar unit which performs a certain function, such as alarm (1) or (2), ground (5), or trip (3), rather than giving calibration instructions for each complete relay. In this way, considerable duplication of instructions has been eliminated.

Alarm Unit (1)

Connect the relay as described under Acceptance Tests for the particular relay involved. Screw the two magnetic shunts all the way in, then back them out five turns each. With the relay energized at rated voltage, set the monitoring current at 1.3 or 2.3 ma. d.c. for 2 or 3-terminal relay respectively, by adjusting the external resistor. If the relay does not close its right-hand contact, turn in the left shunt screw until the right-hand contact just closes. If the right-hand contact is closed at 1.3 ma., turn in the right shunt until a point is reached when the right-hand contact is just closed at 1.3 ma.

Now drop the current to 0.7 ma. and adjust the opposite shunt until the left-hand contact just closes

at 0.7 ma. d.c. At 1.0 ma. d.c., the moving contact should float half way between the two sets of stationary contacts with a 0.025-inch gap on each side. Recheck the high and low current calibration several times, touching up the shunt adjustments as required to obtain the desired calibration.

Polarization Check

For all the source relays, which are listed below, make the following additional calibration check:

- PMA PM-13 (a.c. and d.c.)
- PMA-1 PMG-13 (a.c. and d.c.)
- PMD
- PMD-1

After calibration as described in the previous sections, connect a 20,000 ohm resistor (or 10,000 ohms for 3-terminal applications) across the output terminals, and energize the relay at its rated supply voltage. With these connections, approximately one (or two) milliamperes d.c. will flow through the monitor relay coils and external resistor, thus representing normal operating conditions.

Now momentarily (one second or so) apply 48 volts d.c. directly to the pilot-wire terminals of the relay, as indicated in the following table.

Relay	<u>Terminals for Momentary Application of 48 V. d.c.</u>	
	<u>POS.</u>	<u>NEG.</u>
PMA, PMA-1 } PMD, PMD-1 }	6	7
PM-13 (a.c. or d.c.) } PMG-13 (a.c. or d.c.) }	8	9

After momentary application of the transfer-trip voltage as just explained, recheck the calibration of the monitoring alarm unit (1). If it has changed, make necessary trimming adjustments of the shunt screws until there is no change in calibrating of the alarm unit (1) after the transfer-trip voltage has been applied. The purpose of this test is to compensate for the small residual magnetism in the relay unit. The ground alarm unit(5) will not be affected by this test as the ampere-turns of the two windings cancel each other.

Alarm Unit (2)

For the alarm unit of the PM-2 or PM-23 relays, adjust the shunts so that the relay moving contact

floats at one ma. d.c., and closes the left-hand contact at 0.7 ma. d.c. The moving contact should float midway between the contact and contact stop at 1.0 ma. d.c. There is no high-current calibration for this relay unit.

Now apply 48 volts d.c. momentarily (one second or so) across the alarm unit coil-circuit terminals in a direction to operate the alarm relay. Then recheck the alarm unit calibration. If there is any change, touch up the shunt adjustments until there is no change in calibration after 48 v. d.c. has been applied.

Tripping Unit (3)

To calibrate the tripping unit of the PM-3, PM-13, PMG-13, or PM-23 relays apply a d.c. voltage as explained below, to the following relay terminals:

Relays	D.C. Voltage	
	Pos.	Neg.
PM-3	9	8
PM-13 (a.c. or d.c.)	16	20
PMG-13 (a.c. or d.c.)	8	9
PM-23	8	9

Momentarily (one second or so) apply 48 volts d.c. to the terminals shown in the chart. Then starting with both shunts all the way in, turn out the right-hand shunt screw until the relay closes its right-hand trip contact at 14 volts d.c. (This will give approximately 2 ma. through the relay coil.) Now draw out the left-hand shunt until the relay resets with toggle action (not gradually) at not less than 10 volts d.c. When the calibration is approximately correct, again apply 48 volts d.c. to the indicated terminals, then recheck the pickup and dropout voltage, making any necessary trimming adjustments of the shunts. When the relay is properly adjusted, the application of 48 volts.d.c. will not change the pickup or dropout voltage points. The relay should trip and reset with toggle action in this application. This will require both shunt screws to be withdrawn farther than for floating action.

Ground Alarm Unit (5)

For the PM-5 relay, turn both shunt screws all the way in, then back them out five turns each. Pass a current of 0.3 ma. d.c. in terminal 6 and out terminal 7. Following the same general procedure as described previously in the section entitled "Alarm Unit (1)," adjust the shunt screws so that the left-hand contact closes at 0.3 ma. Now pass 0.3 ma. d.c.

TYPE PM MONITORING RELAYS

in terminal 9 and out terminal 8, and adjust for closing of the right-hand contact at 0.3 ma. Recheck both pickup points several times, and make trimming adjustments of both shunts as required to obtain contact closing at 0.3 ma. d.c. in each direction.

For the ground unit (5) of the PMA, PMD, and PMG-13 relays, connect a variable resistance of about 50,000 ohms in series with a 0-1 d.c. milliammeter between the terminals indicated in the following table:

Turn the shunts all the way in, then back them out five turns each. With the relay connected as shown in the left-hand column of the table, apply rated voltage to the relay and adjust the 50,000-ohm resistor for 0.3 ma. d.c. Now following the procedure in the previous paragraph for the PM-5 relay, adjust the shunts until the left-hand contact closes at 0.3 ma. d.c. Change the connections as indicated in the right-hand column, and adjust the opposite shunt until the right-hand contact closes. Recheck back and forth several times and make necessary trimming adjustments to obtain pickup at 0.3 ma. In each direction. The armature will move gradually as the

current is changed for this relay unit.

ICS Unit

Close the main relay tripping contact circuit with a jumper connected directly across the contact terminals of the polar unit. Pass sufficient direct current through the relay trip circuit to close the contacts of the ICS unit. This value of current should not be greater than the ICS tap setting being used (0.2 or 2.0). The indicator target should drop freely. The contact gap should be approximately 0.047 inch between the bridging moving contact and the adjustable stationary contacts. The bridging moving contact should touch both stationary contacts simultaneously.

RENEWAL PARTS

Repair work can be done most satisfactorily at the factory. However, interchangeable parts can be furnished to the customers who are equipped for doing repair work. When ordering parts, always give the complete nameplate data.

Ground Alarm (5) Calibration		
Relay	<u>Relay Terminals</u>	
	L.H. Contact Check	R.H. Contact Check
PMA	3 ⁺ and 6	3 and 7 ⁺
PMD	5 ⁺ and 6	5 and 7 ⁺
PMG-13	3 ⁺ and 8	3 and 9 ⁺

+ Milliammeter positive to this terminal

INDEX TO FIGURES

INTERNAL SCHEMATICS

FIG. NO.		PAGE NO.
1	Polar Unit Permanent Magnet Flux Paths	2
2	PMA Relay - AC supply - two terminal line	14
3	PMA-1 Relay - AC supply - two terminal line	14
4	PMA Relay - AC supply - three terminal line	14
5	PMA-1 Relay - AC supply - three terminal line	14
6	PMD Relay - DC supply - two terminal line	15
7	PMD-1 Relay - DC supply - two terminal line	15
8	PMD Relay - DC supply - three terminal line	15
9	PMD-1 Relay - DC supply - three terminal line	15
10	PM-2 relay in FT21 case	16
11	PM-3 relay in FT11 case	16
12	PM-4 relay (auxiliary unit)	16
13	PM-5 ground detector relay	16
14	PM-23 relay in FT21 case	17
15	PM-13 Relay - DC supply - two terminal line	17
16	PM-13 Relay - DC supply - three terminal line	17
17	PM-13 Relay - AC supply - two or three terminal line	17
18	PMG-13 Relay - DC supply - two terminal line	18
19	PMG-13 Relay - DC supply - three terminal line	18
20	PMG-13 Relay - AC supply - two or three terminal line	18

EXTERNAL SCHEMATICS

21	PMD relay with PM-23 or PM-4, two terminal line	19
22	PMA relay with PM-23 or PM-4, two terminal line	19
23	DC type PMG-13 with PM-23 or PM-4, two terminal line	20
24	PMD relay with PM-23 & PM-4, three terminal line	20
25	AC type PMG-13 relay with PM-23, two terminal line	21
26	DC type PM-13 & PM-5 with PM-23 or PM-4, two terminal line	21
27	DC type PM-13 relay with PM-23 or PM-4, two terminal line	22

OUTLINE & DRILLING PLANS

28	10 mfd. capacitor	23
29	Remote trip resistor	23
30	PM-4 projection molded case	23
31	PM-4 semi-flush molded case	23
32	PM-3, PM-5, & PMD-1 in FT11 case	24
33	PM-2, PM-23, PMA-1, & PMD in FT21 case	25
34	PMA in FT31 case	26
35	PM-13 and PMG-13 in FT32 case	27

TYPE PM MONITORING RELAYS

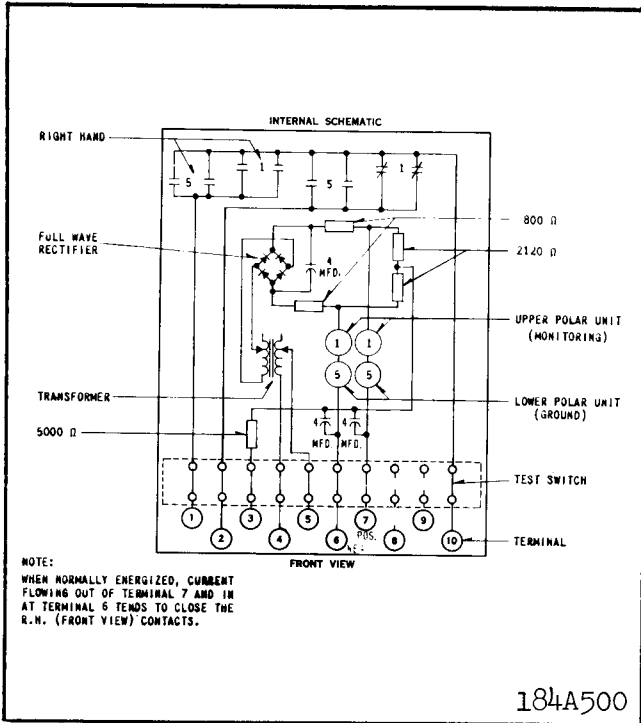

Fig. 2. Internal schematic of the type PMA relay in FT 31 case - 120 volt, 60 cycle supply - For two terminal lines.

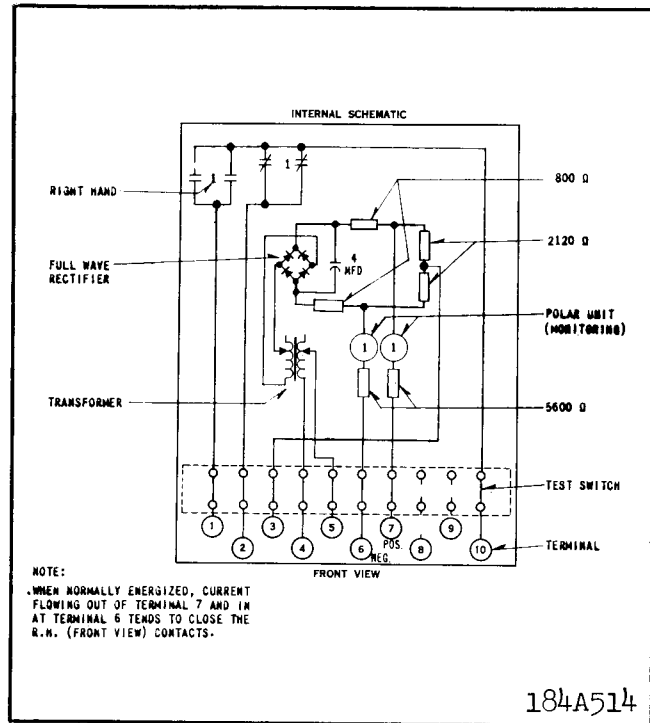

Fig. 3. Internal schematic of type PMA-1 relay in the FT 21 case - 120 volts, 60 cycle supply - For two terminal lines.

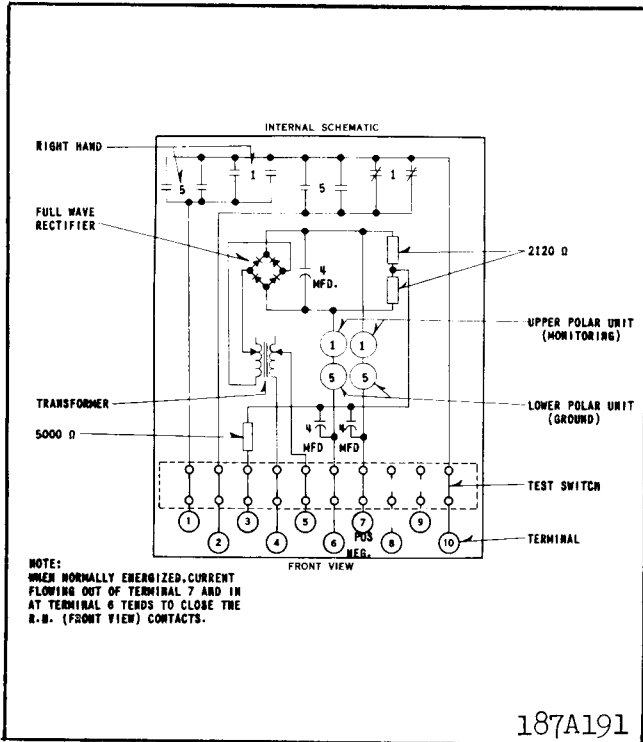

Fig. 4. Internal schematic of type PMA relay in FT 31 case - 120 volt, 60 cycle supply - For three terminal lines.

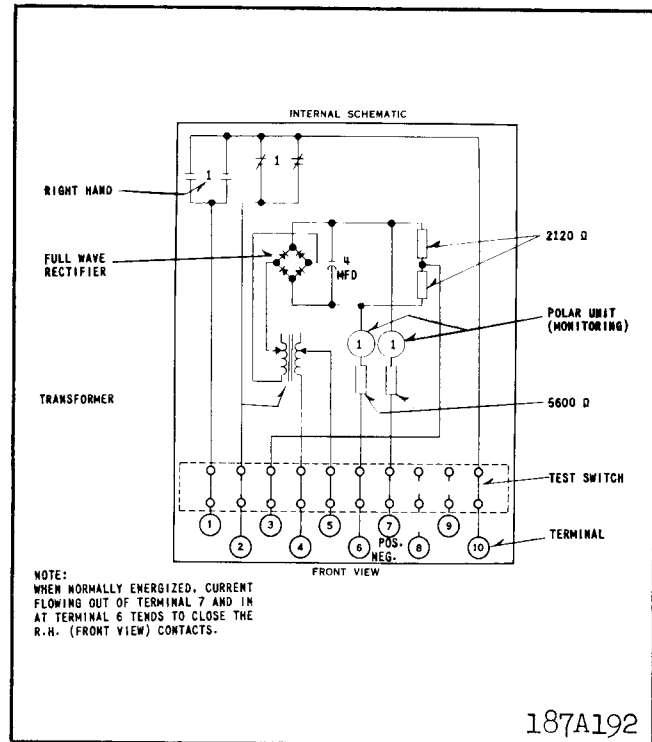

Fig. 5. Internal schematic of type PMA-1 relay in FT 21 case - 120 volt, 60 cycle supply - For three terminal lines.

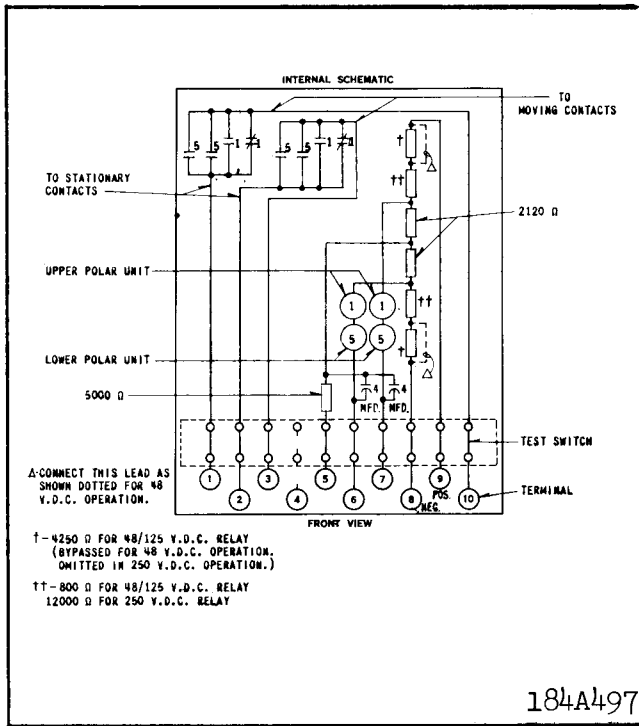

Fig. 6. Internal schematic of the type PMD relay in FT 21 case - DC supply - for two terminal lines.

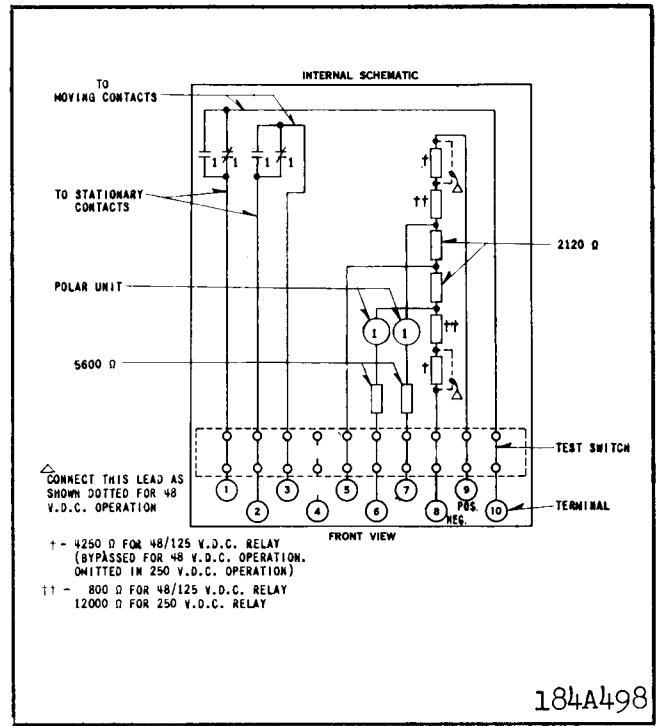

Fig. 7. Internal schematic of the type PMD-1 relay in the FT 11 case - DC supply - For two terminal lines.

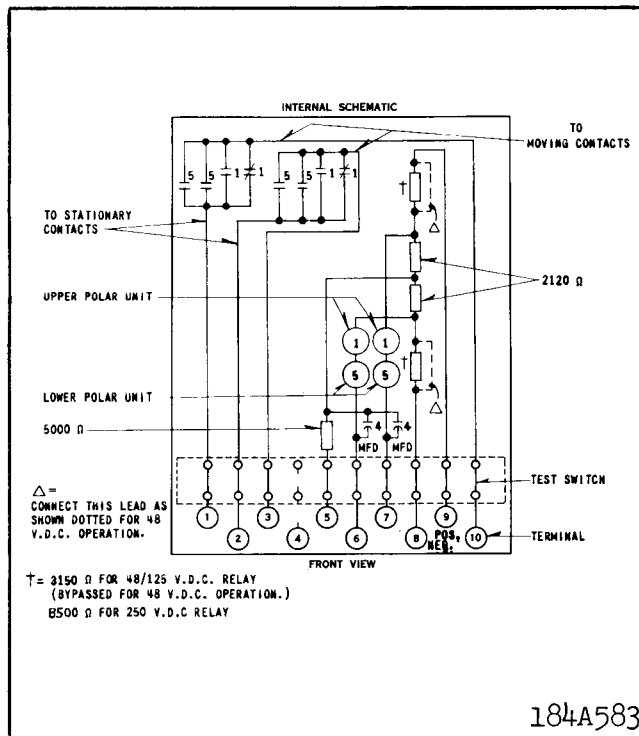

Fig. 8. Internal schematic of the type PMD relay in the FT 21 case - DC supply - For three terminal lines.

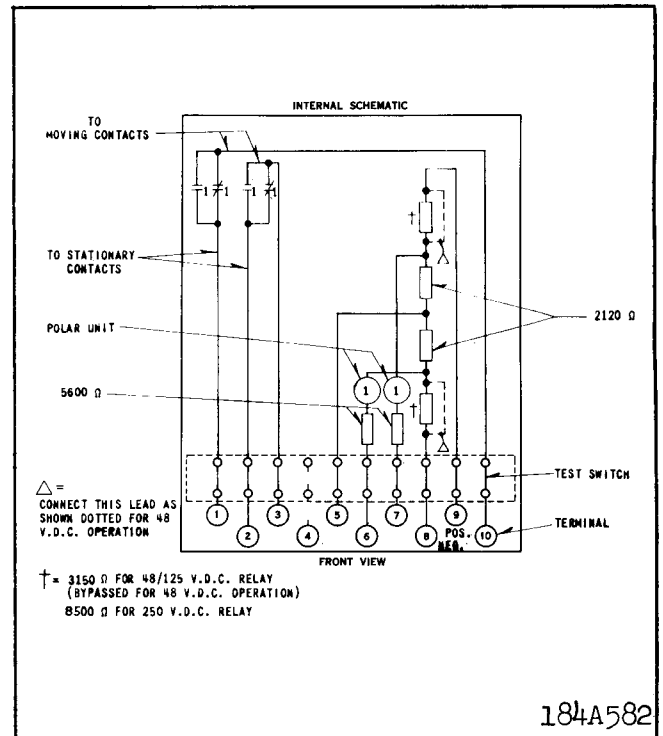

Fig. 9. Internal schematic of the type PMD-1 relay in the FT 11 case - DC supply - For three terminal lines.

TYPE PM MONITORING RELAYS

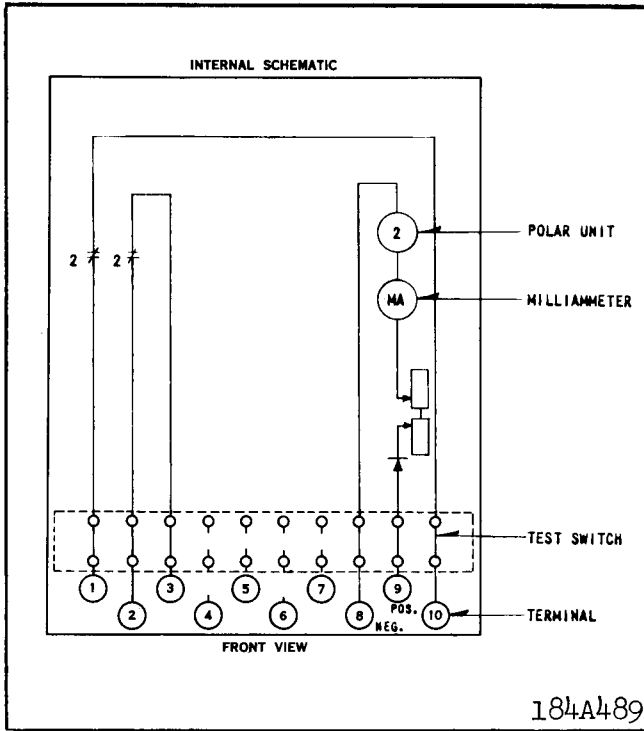

Fig. 10. Internal schematic of the type PM-2 relay in the FT 21 case.

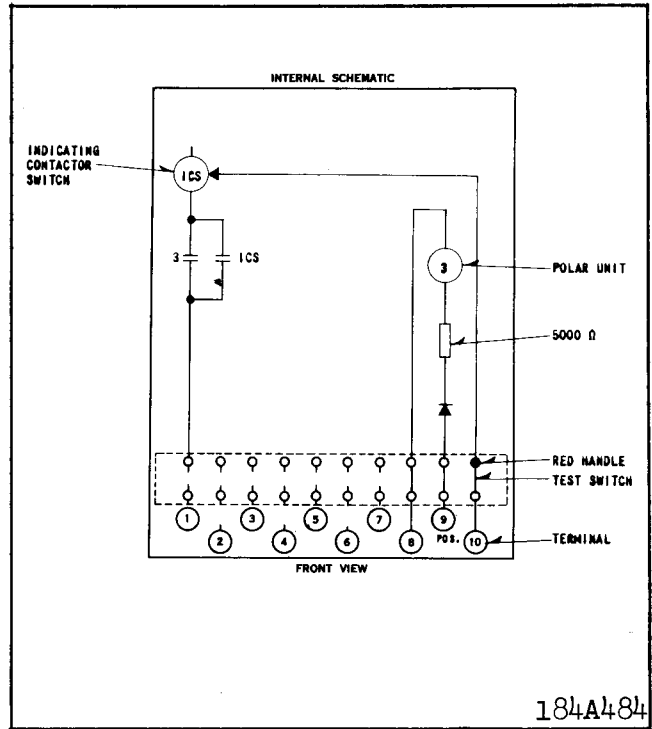

Fig. 11. Internal schematic of the type PM-3 relay in the FT 11 case.

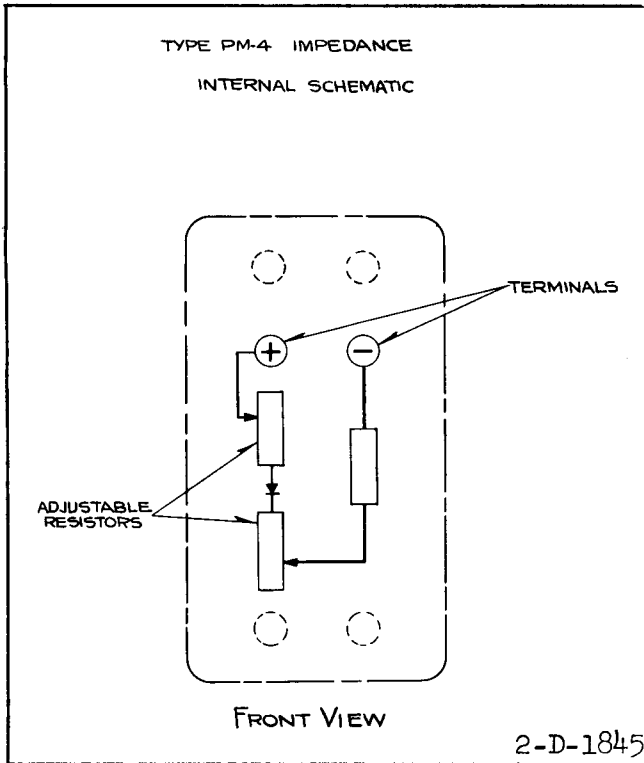

Fig. 12. Internal schematic of the type PM-4 Auxiliary Unit in the small molded case.

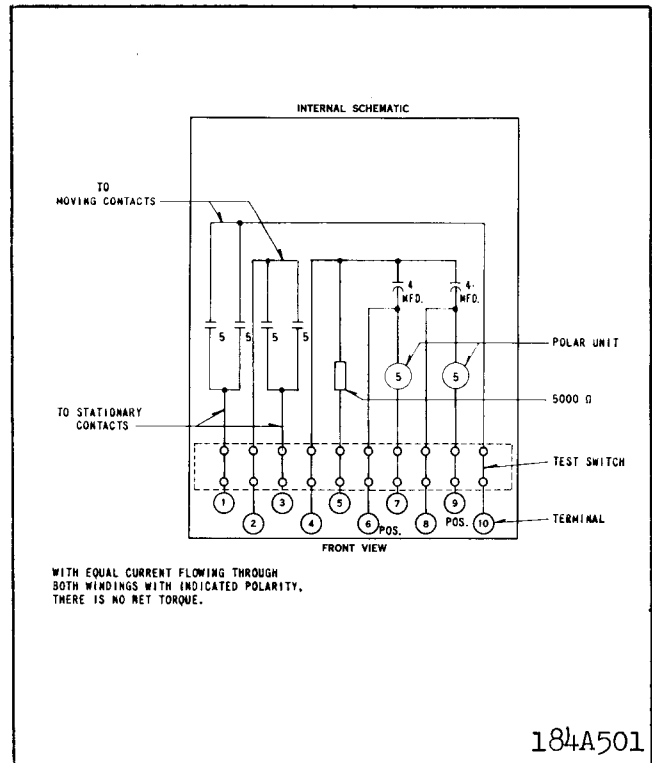

Fig. 13. Internal schematic of the type PM-5 ground detector relay in the FT 11 case.

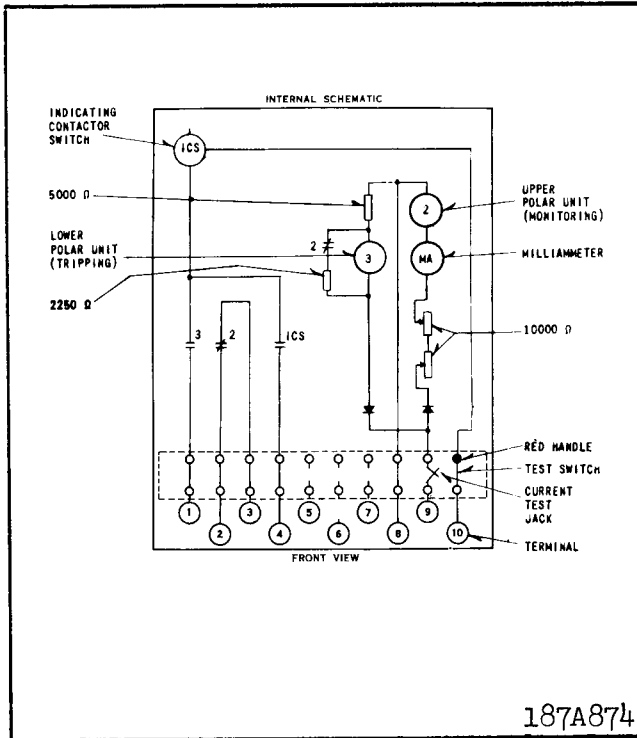

Fig. 14. Internal schematic of the type PM-23 relay in the FT 21 case.

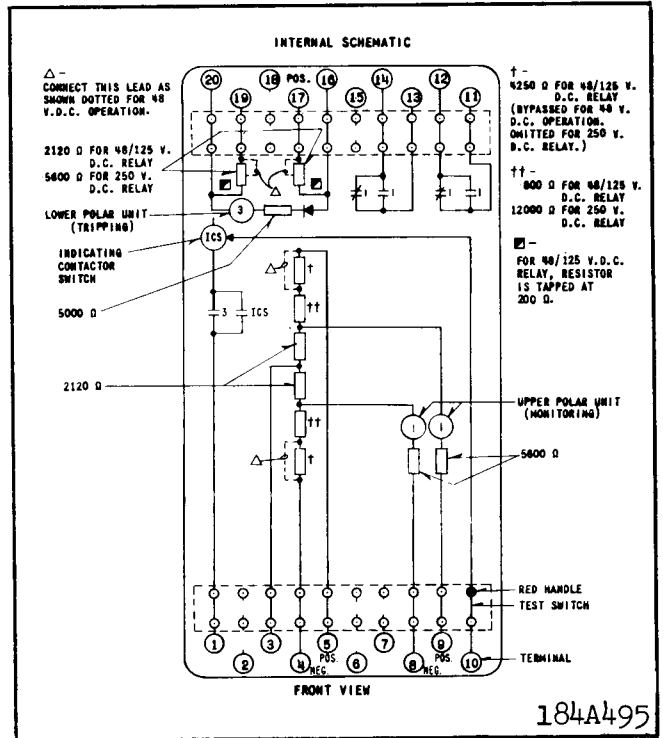

Fig. 15. Internal schematic of the type PM-13 relay in the FT 32 case - DC supply - For two terminal lines.

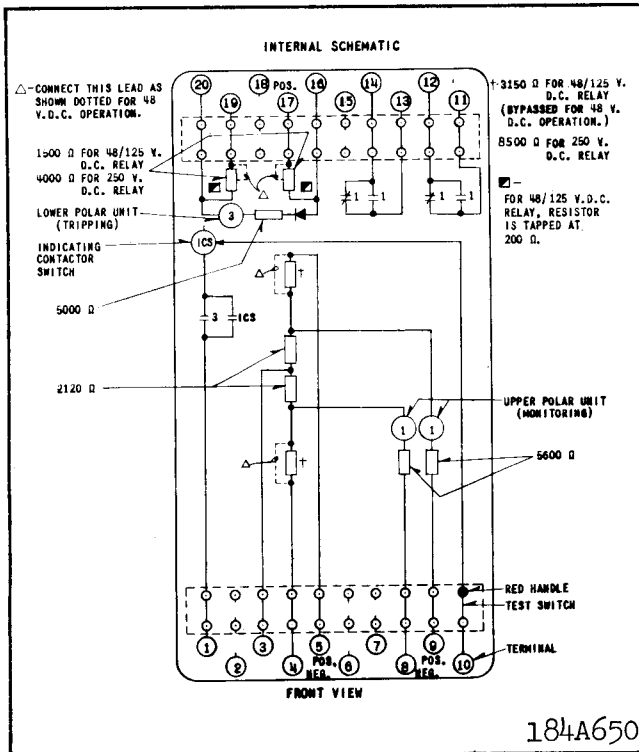

Fig. 16. Internal schematic of the type PM-13 relay in the FT 32 case - DC supply - For three terminal lines.

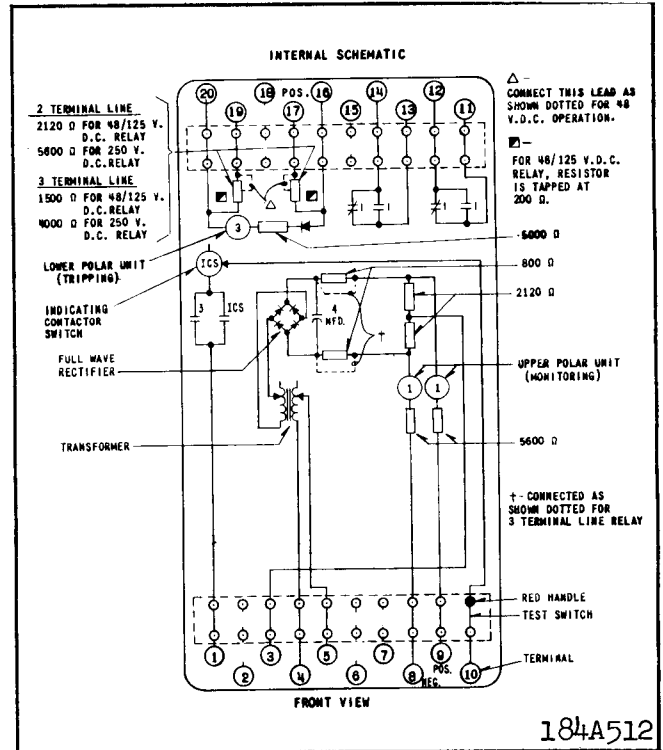

Fig. 17. Internal schematic of the type PM-13 relay in the FT 32 case - 120 volt, 60 cycle supply - For two or three terminal lines.

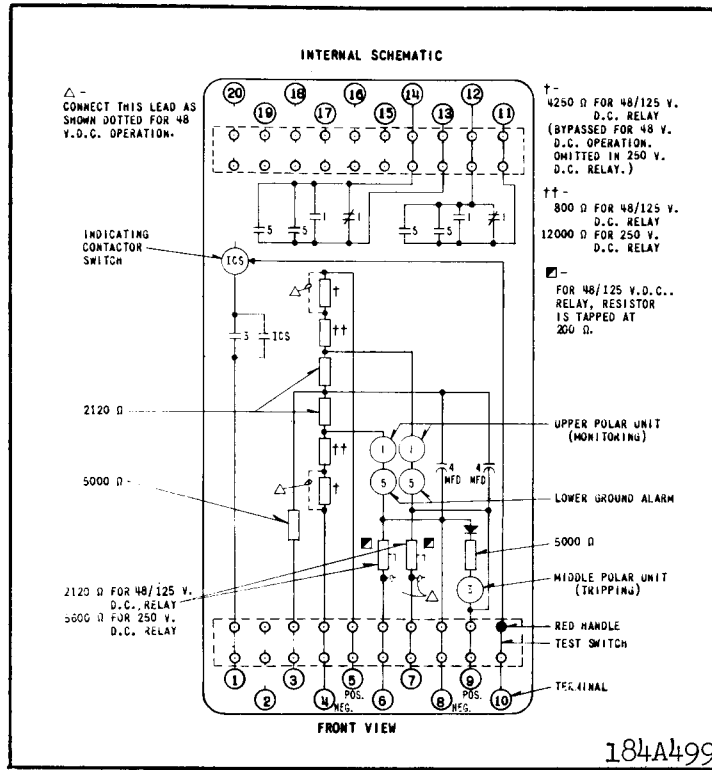

Fig. 18. Internal schematic of the type PMG-13 relay in the FT 32 case - DC supply - For two terminal lines.

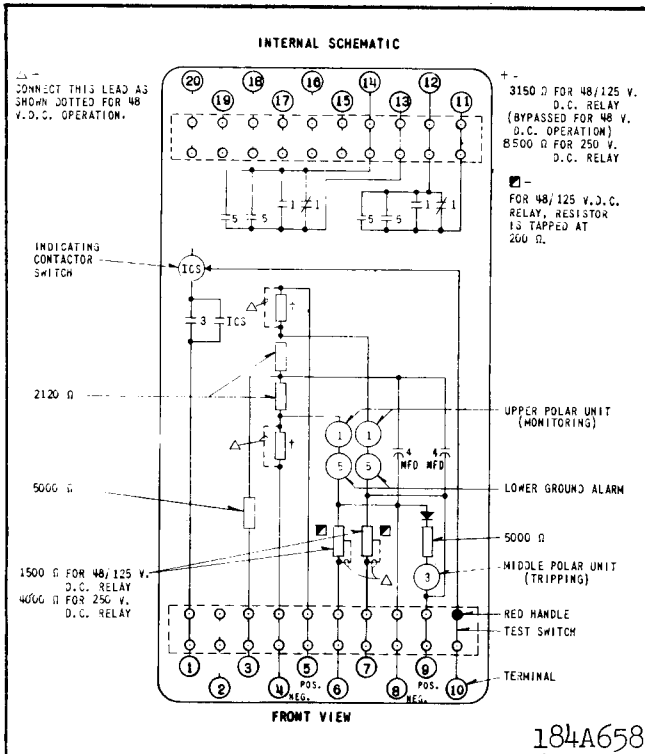

Fig. 19. Internal schematic of the type PMG-13 relay in the FT 32 case - DC supply - For three terminal lines.

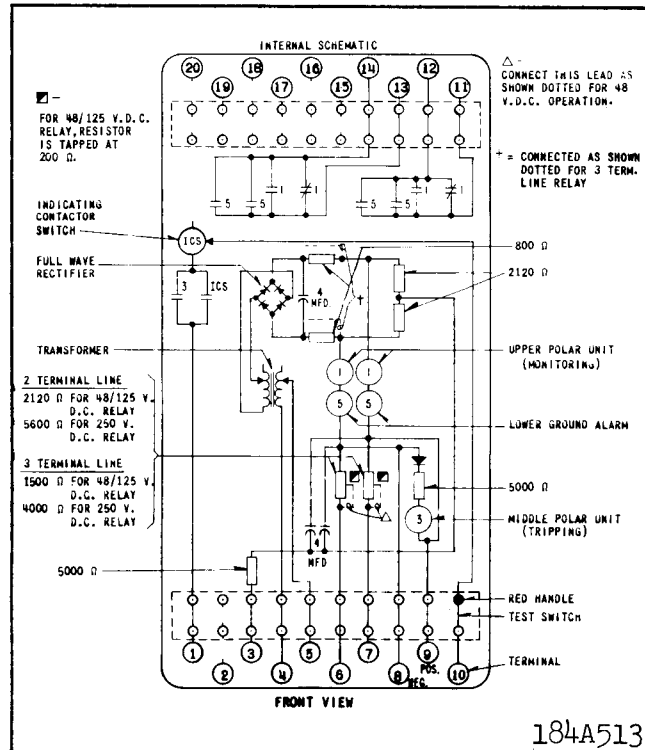
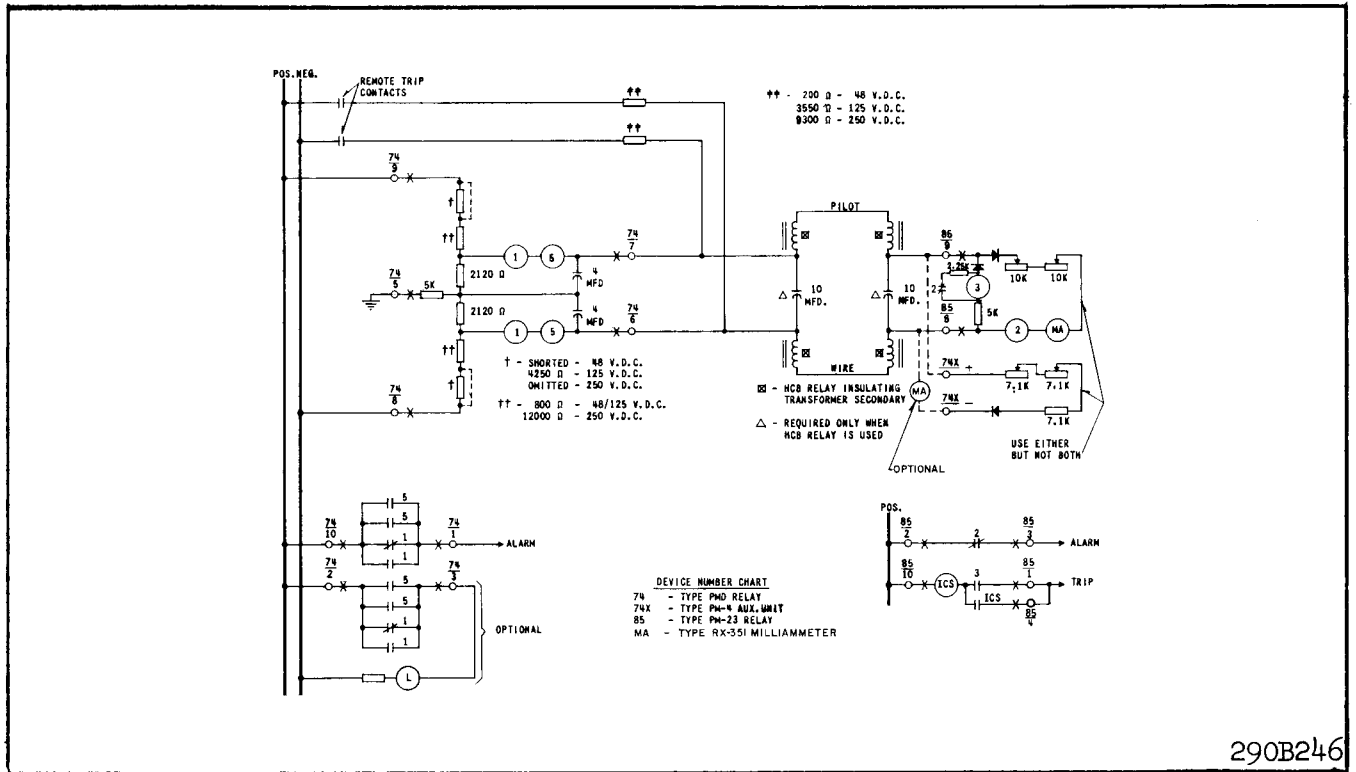

Fig. 20. Internal schematic of the type PMG-13 relay in the FT 32 case - 120 volt, 60 cycle supply - For two or three terminal lines.



TYPE PM MONITORING RELAYS

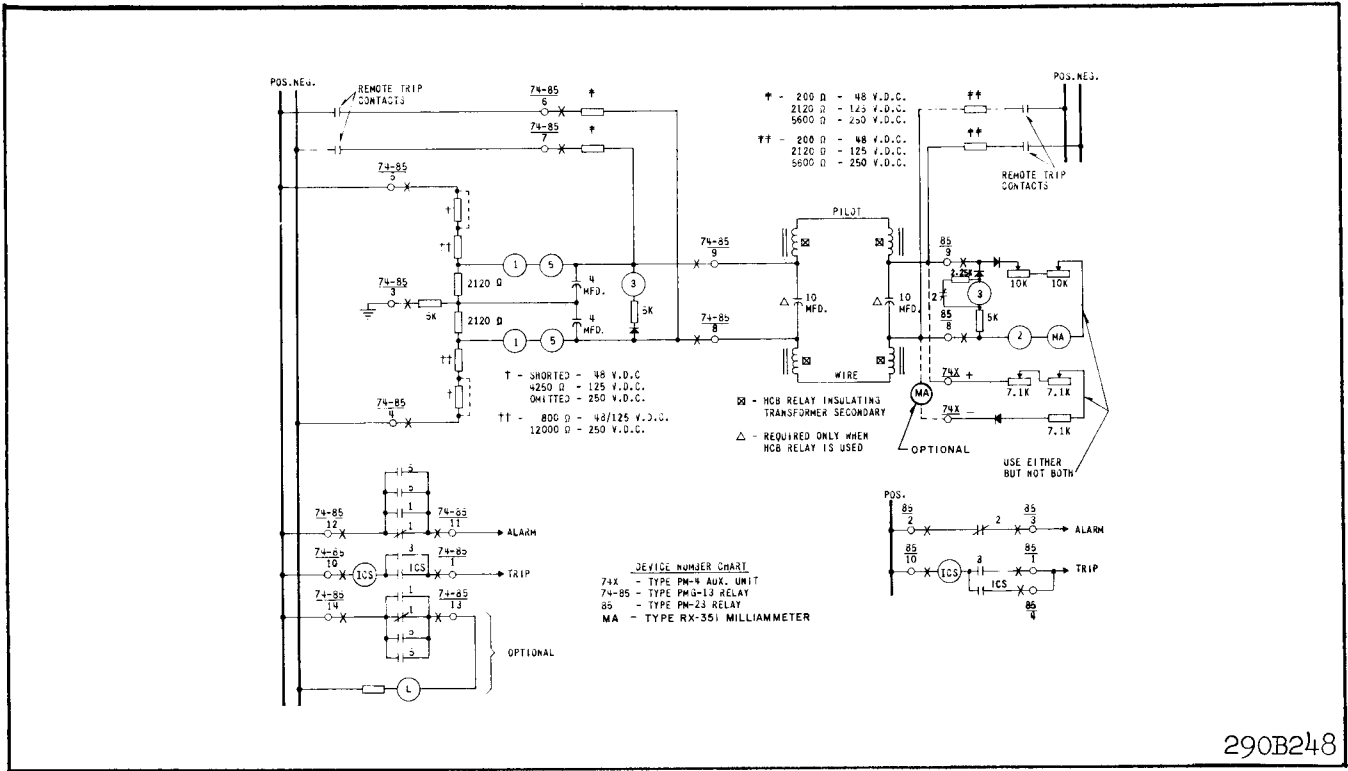

Fig. 23. External schematic of the DC type PMG-13 relay with type PM-23 or PM-4 relay – Two terminal lines.

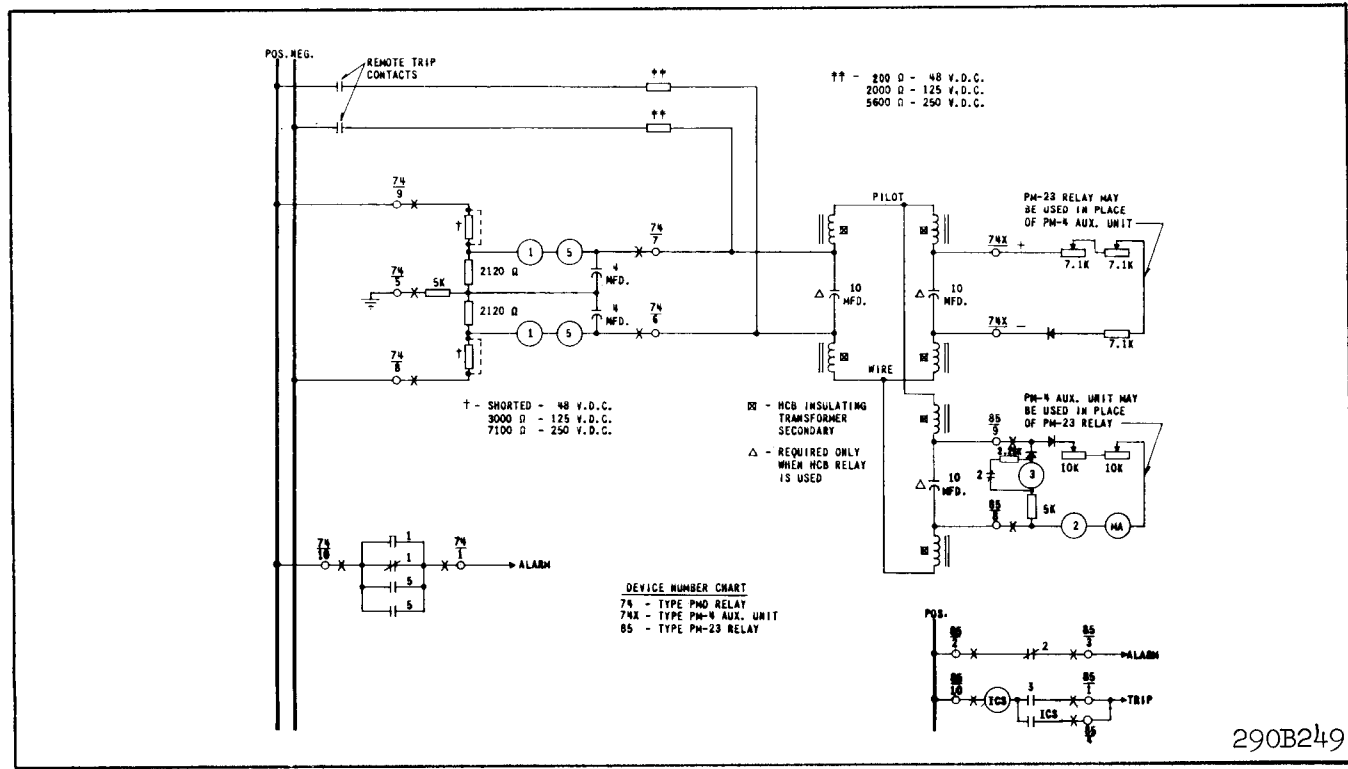

Fig. 24. External schematic of the type PMD relay with type PM-23 and PM-4 relays – Three terminal lines.

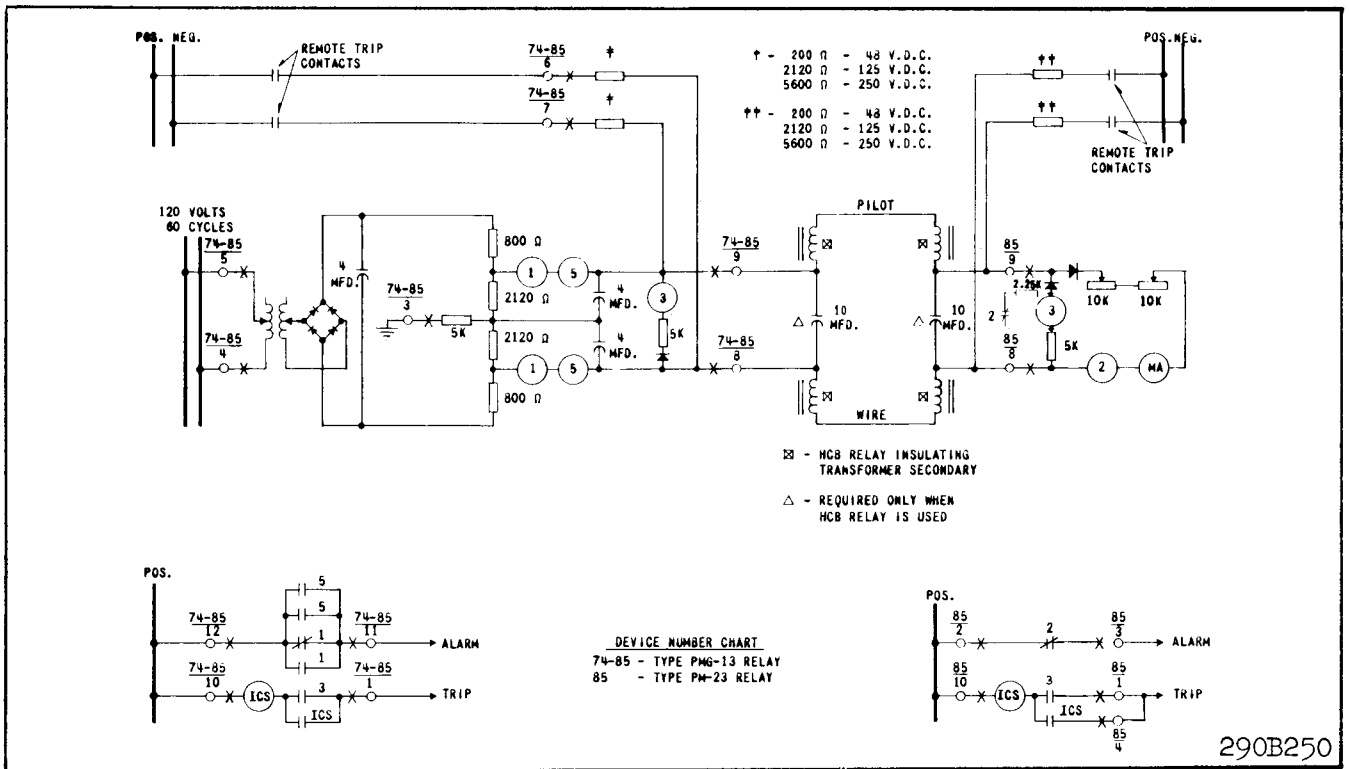

Fig. 25. External schematic of the AC type PMG-13 with type PM-23 relay - Two terminal lines.

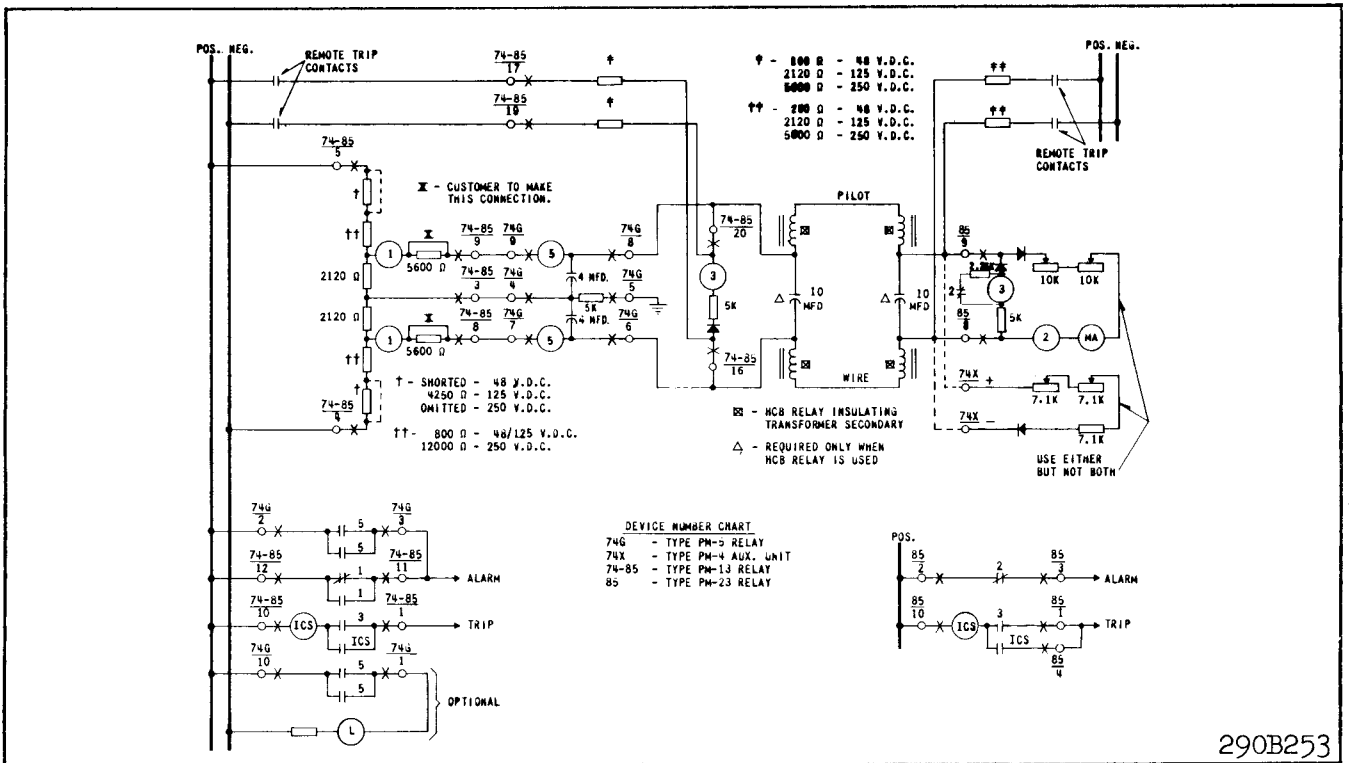

Fig. 26. External schematic of the DC type PM-13 and PM-5 relay with type PM-23 or PM-4 relay - Two terminal lines.

TYPE PM MONITORING RELAYS

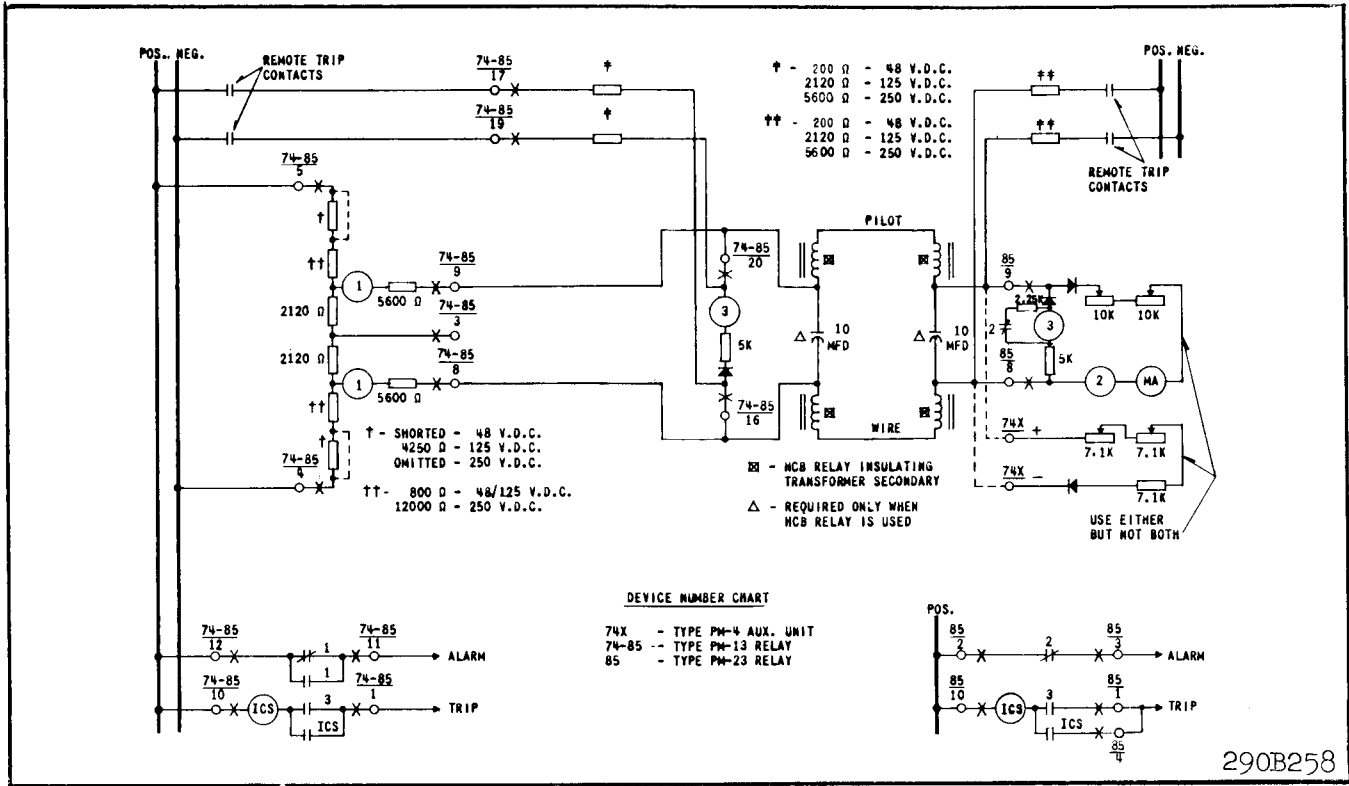

Fig. 27. External schematic of the DC type PM-13 relay with type PM-23 or PM-4 relay - Two terminal lines.

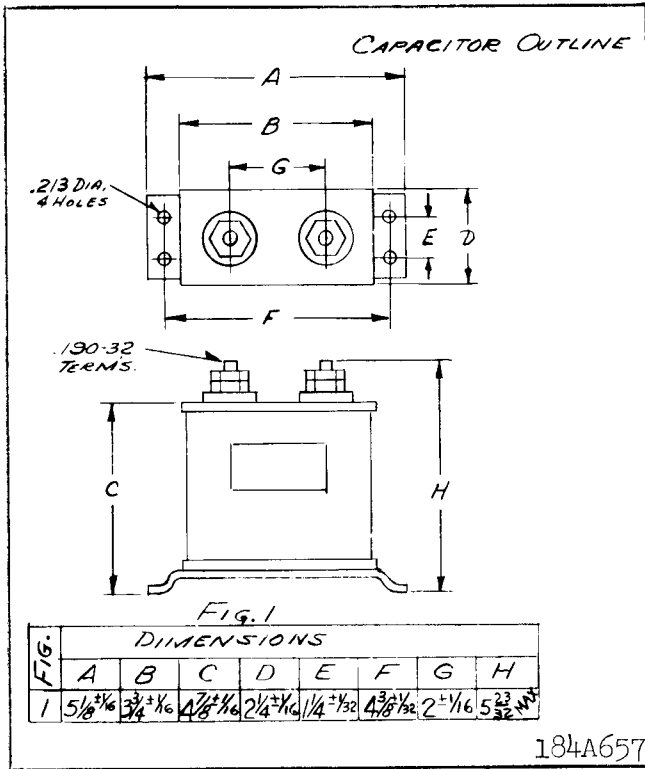

Fig. 28. Outline and Drilling Plan for 10 mfd. capacitor — For reference only.

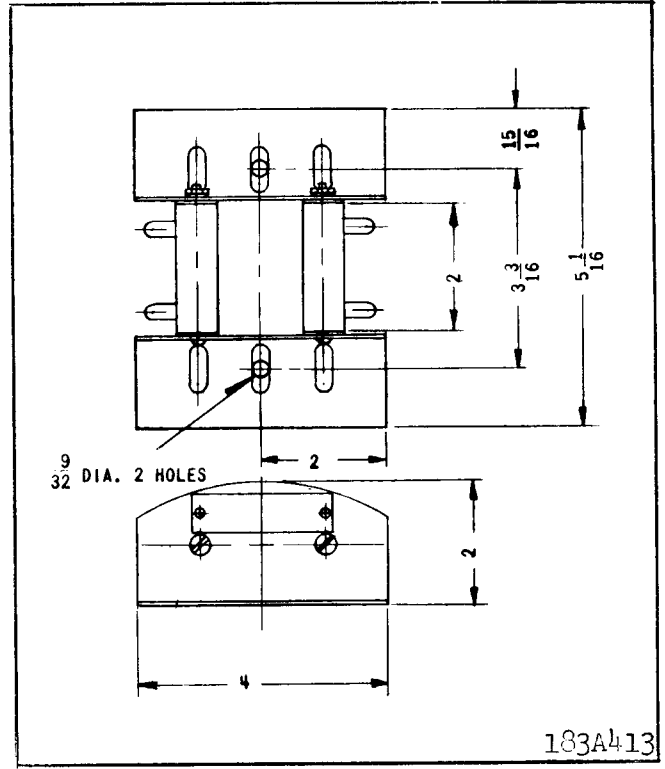

Fig. 29. Outline and Drilling Plan for External Remote trip Resistor Assembly.

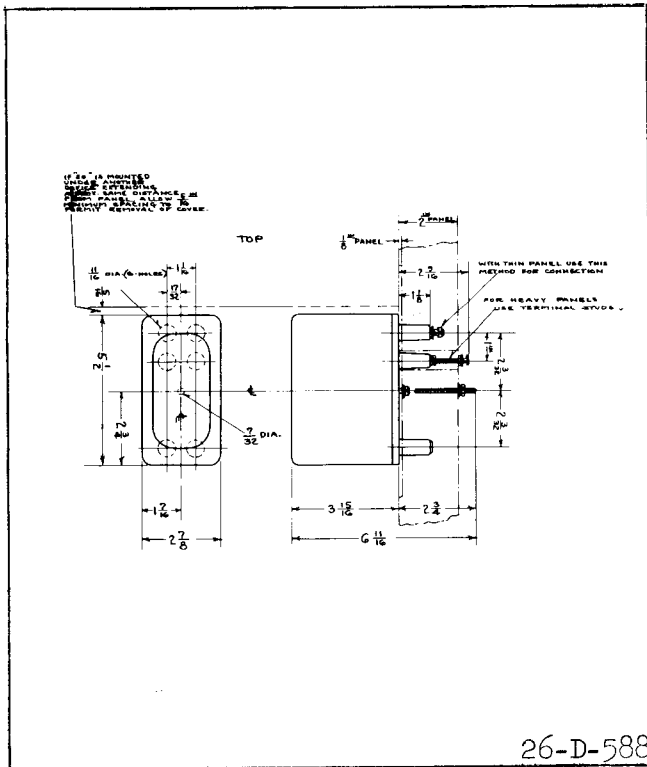

Fig. 30. Outline and Drilling Plan for the type PM-4 Auxiliary unit in the projection molded case.

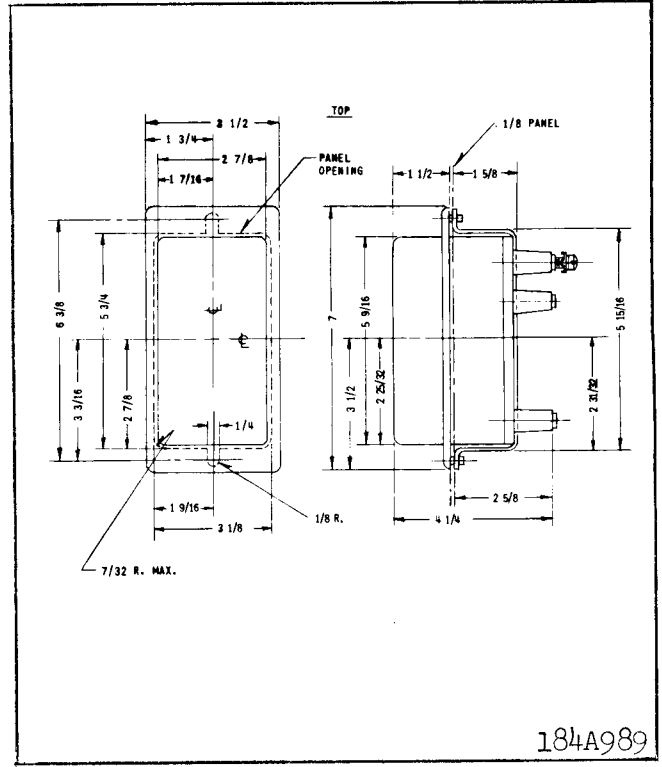

Fig. 31. Outline and Drilling Plan for the type PM-4 Auxiliary unit in the Semi-Flush molded case.

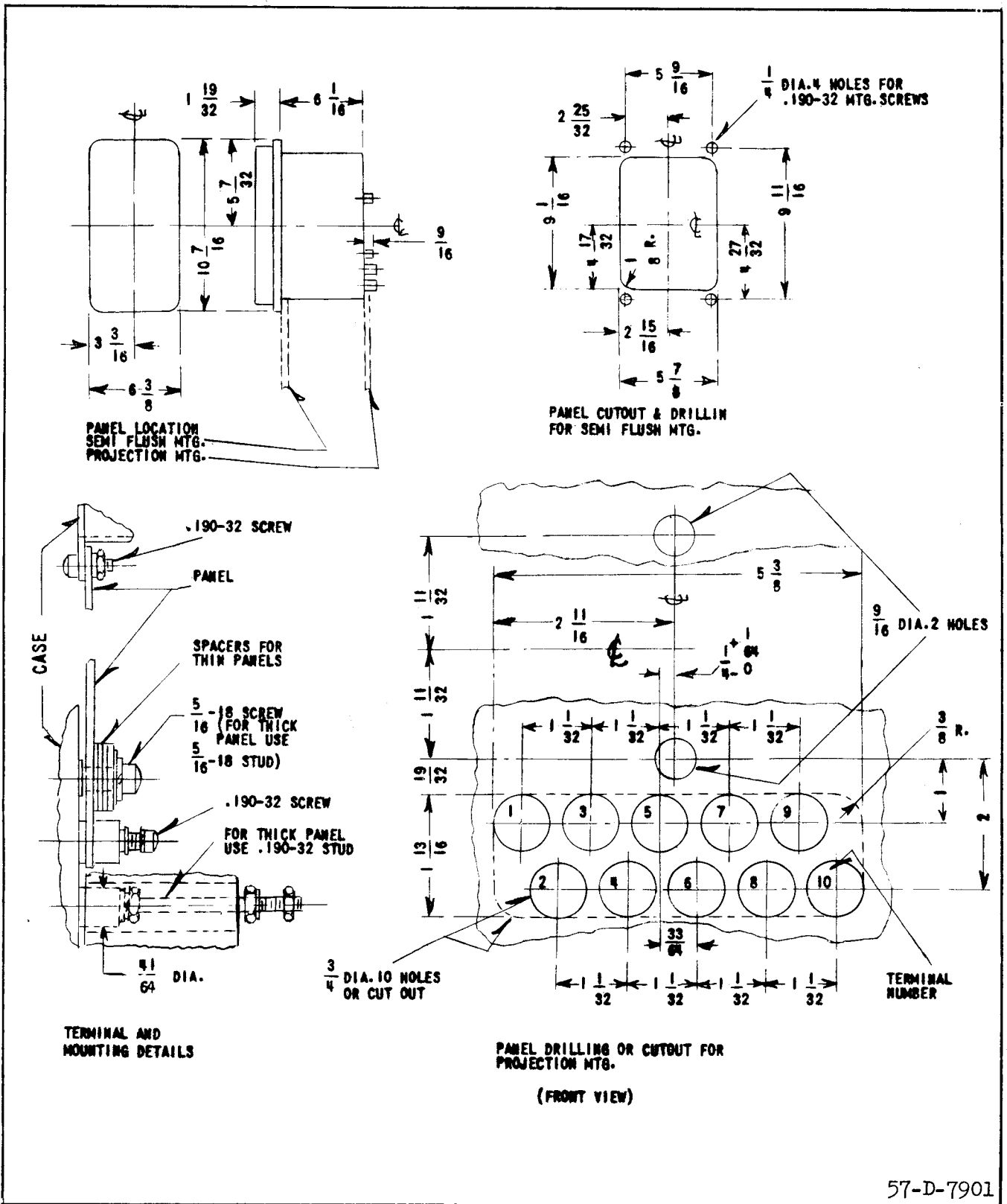
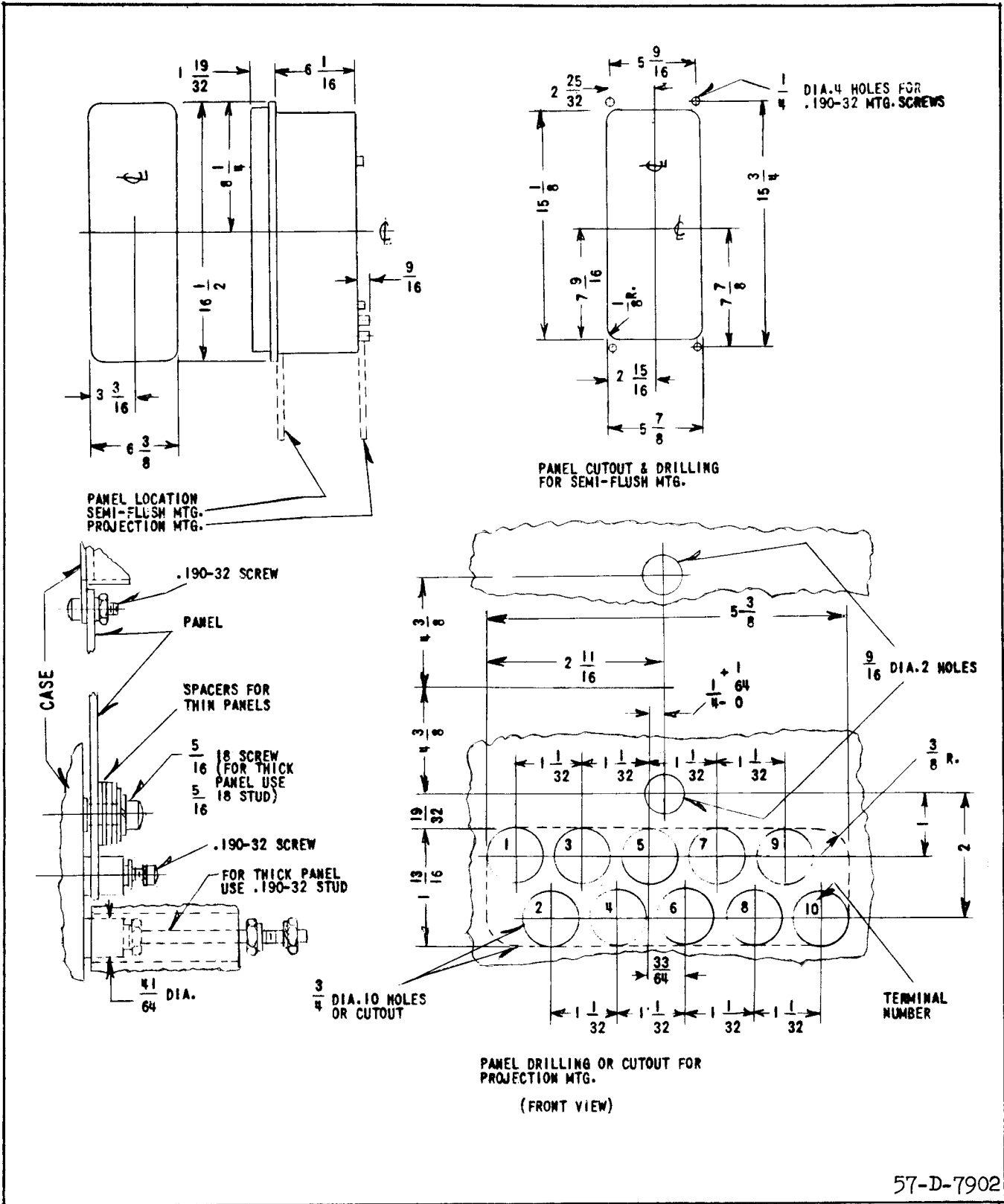
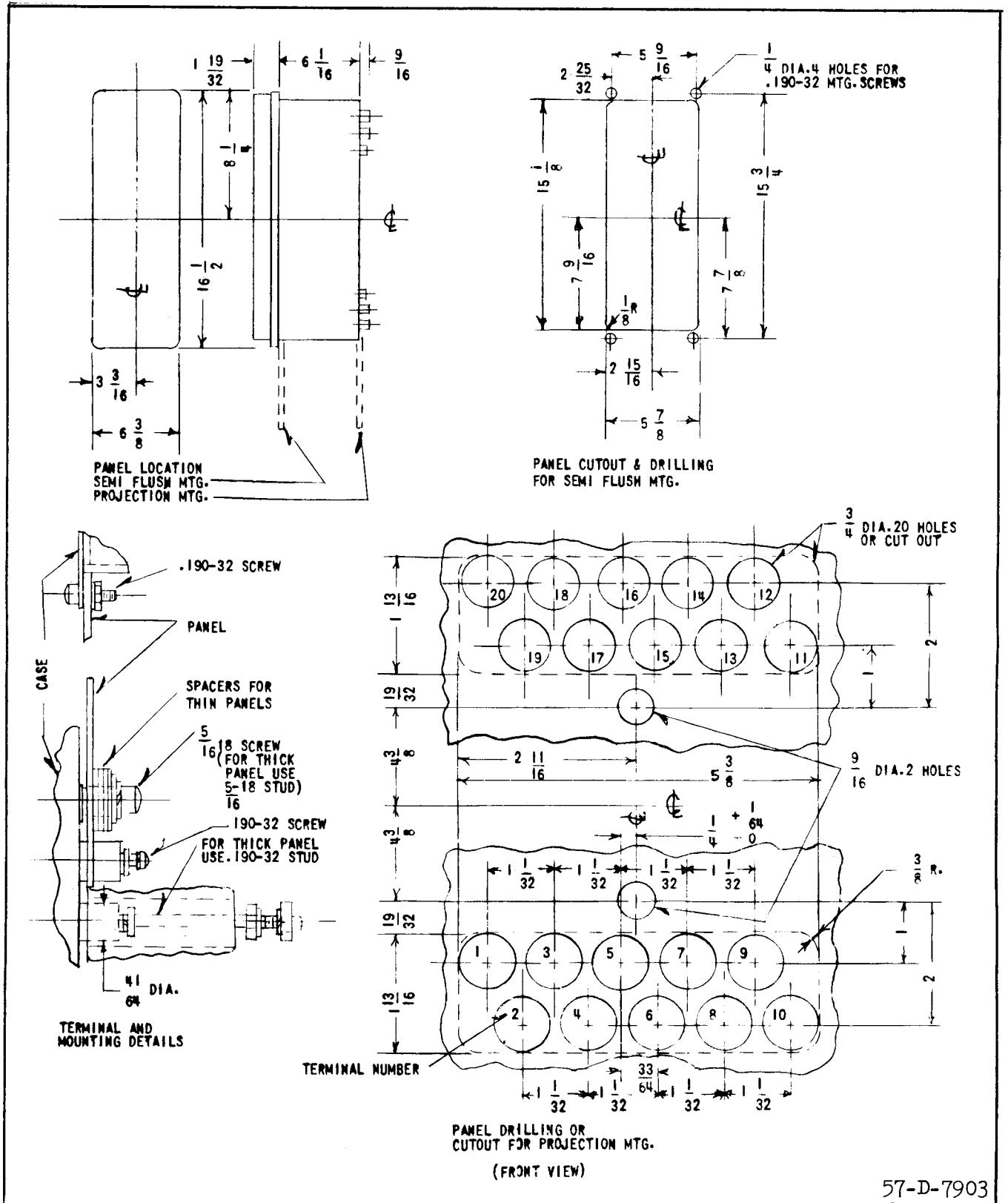

Fig. 33. Outline and Drilling Plan for the type PM-2, PM-23, PMA-1 and PMD relays in the type FT 21 case.



57-D-7902

Fig. 34. Outline and Drilling Plan for the type PMA relay in the type FT 31 case.



57-D-7903

Fig. 35. Outline and Drilling Plan for the type PM-13 and PMG-13 relays in the type FT 32 case.



WESTINGHOUSE ELECTRIC CORPORATION
RELAY-INSTRUMENT DIVISION

NEWARK, N. J.

Printed in U.S.A.

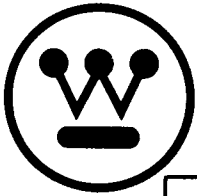

INSTALLATION • OPERATION • MAINTENANCE INSTRUCTIONS

TYPE PM LINE OF RELAYS FOR PILOT-WIRE MONITORING AND TRANSFERRED TRIPPING

CAUTION Before putting protective relays into service, remove all blocking which may have been inserted for the purpose of securing parts during shipment, make sure that all moving parts operate freely, inspect the contacts to see that they are clean and close properly, and operate the relay to check the settings and electrical connections.

APPLICATION

Type PM Monitoring Relays provide continuous monitoring of a pilot-wire circuit to detect open circuits, short circuits, grounds, and wire reversal. In addition, transferred tripping can be effected where the PM-3, PM-13, PMG-13 or PM-23 relays are used. Table I illustrates the functions available with each relay. A 10 mfd. capacitor is supplied with each PM relay. This capacitor provides an a-c path between the two halves of the insulating transformer secondary windings as shown in Figs. 21 through 27.

Each circuit requires the following:

At one end to introduce monitoring current

One of the following:

For a-c Supply

For d-c Supply

PMA	PMD
PMA-1	PMD-1
PM-13 or PMG-13 (a.c.)	PM-13 or PMG-13 (d.c.)

At the other end to receive monitoring current (two-terminal line)

One PM-23 or PM-2 or PM-4

At the other ends to receive monitoring current (three-terminal line)

Two PM-23 or two PM-4 or two PM-2 or any combination of two of these relays.

CONSTRUCTION

PM relays consist of the following:

PMA

PMA-1

1-Polar Alarm Unit (1)	1-Polar Alarm Unit
------------------------	--------------------

1-Polar Ground Unit (5)
1-Tapped Transformer
1-Full-Wave Rectifier
3-4 mfd. Capacitors
1-Set of Potential
Dividing Resistors

PMD

1-Polar Alarm Unit (1)
1-Polar Ground Unit (5)
2-4 mfd. Capacitors
1-Set of Potential
Divider Resistors

PMG-13

1-Polar Alarm Unit (1)
1-Polar Ground Unit (5)
1-Polar Trip Unit (3)
1-Indicating Contactor
Switch
1-Set of Potential
Divider Resistors
1-Tapped Transformer
(A.C. Relay only)
1-Full-Wave Rectifier
(A.C. Relay only)
1-Blocking Rectifier
2-Remote Trip Resistors
3-4 mfd. Capacitors
(A-C Relay)
2-4 mfd. Capacitors
(D-C Relay)

PM-23

1-Polar Alarm Unit (2)
1-Polar Trip Unit (3)
1-Indicating Contactor
Switch (ICS)
1-Milliammeter, 5.0 ma.
1-Set of Adjustable and
Fixed Resistors
2-Blocking Rectifiers

1-Tapped Transformer
1-Full-Wave Rectifier
1-4 mfd. Capacitor
1-Set of Potential
Dividing Resistors

PMD-1

1-Polar Alarm Unit
1-Set of Potential
Divider Resistors

PM-13

1-Polar Alarm Unit (1)
1-Polar Trip Unit (3)
1-Indicating Contactors
Switch
1-Set of Potential
Divider Resistors
1-Tapped Transformer
(A.C. Relay only)
1-Full-Wave Rectifier
(A.C. Relay only)
1-Blocking Rectifier
2-Remote Trip Resistor
1-4 mfd. Capacitor

PM-2

1-Polar Alarm Unit (2)
1-Milliammeter, 5.0 ma.
1-Set of Adjustable
Resistors
1-Blocking Rectifier

TYPE PM MONITORING RELAYS

PM-3

- 1-Polar Trip Unit (3)
- 1-Resistor
- 1-Blocking Rectifier
- 1-Indicating Contactor Switch (ICS)

PM-4

- 1-Blocking Rectifier
- 1-Set of Adjustable & Fixed Resistors

PM-5

- 1-Polar Ground Unit (5)
- 2-4 mfd. Capacitors
- 1-Fixed Resistor

TABLE I

FUNCTION	PMA & PMD	PMA-1 & PMD-1	PM-13	PMG-13	PM-23	PM-2	PM-3	PM-4	PM-5
Monitoring Current Source	X	X	X	X					
Receives Monitoring Current					X	X		X	
Trouble Alarm	X	X	X	X	X	X			X
Transmits Trip Signal	X †	X †	X	X	X †	X †	X †	X †	
Receives Trip Signal			X	X	X		X		
Sensitive Ground Detection	X			X					X
Measures Monitoring Current					X	X			

† With External Resistors

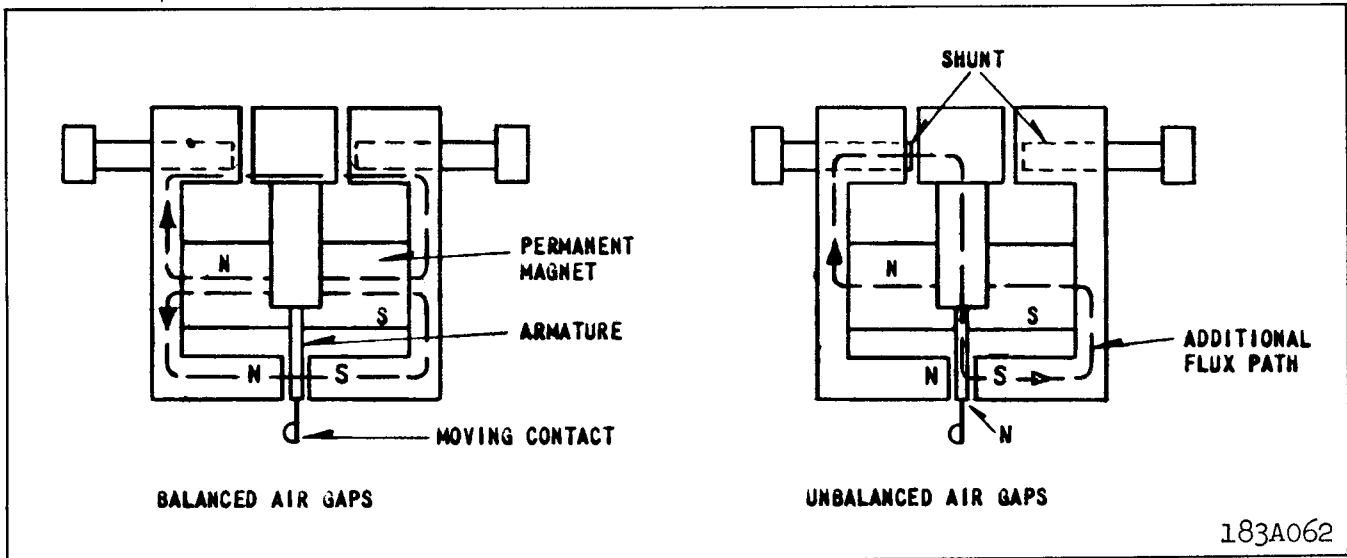

Fig. 1. Polar Unit Permanent Magnet Flux Paths.

183A062

Polar Unit

The polar unit consists of a rectangular shaped magnetic frame, an electromagnet, a permanent magnet, and an armature. The poles of the crescent shaped permanent magnet bridge the magnet frame. The magnetic frame consists of three pieces joined in the rear with two brass rods and silver solder. These non-magnetic joints represent air gaps, which are bridged by two adjustable magnetic shunts. The winding or windings are wound around a magnetic core. The armature is fastened to this core and is free to move in the front air gap. The moving contact is connected to the free end of a leaf spring, which, in turn, is fastened to the armature.

Indicating Contactor Switch

The d-c indicating contactor switch is a small clapper type device. A magnetic armature, to which leaf-spring mounted contacts are attached, is attracted to the magnetic core upon energization of the switch. When the switch closes, the moving contacts bridge two stationary contacts, completing the trip circuit. Also during this operation two fingers on the armature deflect a spring located on the front of the switch, which allows the operation indicator target to drop. The target is reset from the outside of the case by a push rod located at the bottom of the cover.

The front spring, in addition to holding the target, provides restraint for the armature and thus controls the pickup value of the switch.

OPERATION

Pilot Wire Monitoring

Monitoring current is introduced into the pilot wire as shown in the external schematics, figures 21 to 27, by the monitoring current source. External schematics showing other combinations are available on request. A nominal 20 volts is impressed across the 10 mfd. capacitor at the left-hand line terminal in Figures 21 to 27. This voltage produces a current circulating through one winding of the HCB insulating transformer, one pilot wire, the PM-23, PM-2, or PM-4, and back through the other pilot wire and the other winding of HCB insulating transformer.

Adjustment of the resistors of the PM-23, PM-2 or PM-4 relay at the other end of the pilot wire provides a normal one-milliampere d-c circulating current. In the case of three-terminal lines, the monitoring source relay output current is 2 ma. in order to pro-

vide each receiving end relay with 1 ma. The alarm unit of the monitoring current source relay is adjusted to float between the high and low current contacts with normal monitoring current. The PM-23, receiving-end alarm relay, is adjusted to float between the low-current alarm contact and a contact stop with 1 ma. flowing.

Short Circuits

A complete or partial short circuit on the pilot wires increases the current in the current-source relay, causing the high-current alarm contacts to close. The resulting current decrease in the PM-23 relay closes the alarm contact. Short circuits of 5000 ohms or less will be detected.

Open Circuits

Current decreases to zero in all relays. Low-current alarm contact of the current source relay closes. Alarm contact of PM-23 relay closes.

Reversed Wires

On applications using the PM-23 relay, current increases in the sending end relay to close the high-current alarm contacts. Current drops to zero in the PM-23 relay monitoring coil to close the low-current alarm contacts.

If the pilot wire should be opened and reclosed with reversed connections when the PM-23 relay is in service, the alarm contact (2) in the PM-23 drops out. The alarm contact dropping out shunts the trip unit coil (3), and prevents the trip unit contact (3) from operating momentarily. The trip unit contact is prevented from operating because the capacitor at the sending end discharges through the pilot wire and the trip unit (3) circuit. This will have no effect on remote trip operation.

The current decreases in both sending and receiving end relays when the PM-2, or PM-4 relays are used. Low current alarm contacts close.

The voltage-divider circuit of the PMA, PMD, and PMG-13 source relays has its midpoint grounded through a current-limiting resistor. Thus, a pilot-wire ground will cause an increase in current in one coil circuit, and a decrease in the other one. This unbalance in the current flowing through the two windings (5) of the ground alarm relay unit will cause it to close one of its contacts (depending on which pilot wire is grounded) to give an alarm. Grounds of 10,000 ohms or less will be detected.

TYPE PM MONITORING RELAYS

For adding the sensitive ground detection where PMA-1, PMD-1, or PM-13 relays have been installed, the PM-5 relay can be added to the circuitry, as shown in figure 24. This relay also has a 10,000-ohm ground sensitivity.

Transferred Tripping

Breakers located at the PMG-13 or PM-13 and PM-3 or PM-23 stations can be tripped by the application of a d-c voltage to the pilot wires at remote locations, as shown in figures 21 to 27. Transferred tripping can be effected from any location by applying 48 volts d-c (through dropping resistors when required) to the pilot wire with polarity opposite to that of the monitoring voltage. When tripping the PM-23, the current is increased above 2.0 ma, in reverse direction, to close the trip contact. When tripping the PMG-13 or PM-13, the reversed d.c. voltage operates the trip unit (3).

See Tables II and III for tripping resistor values. Nominal tripping currents is 5ma. at all rated voltages.

Polar Unit

Polar unit flux paths are shown in figure 1. With balanced air gaps, permanent magnet flux flows in two paths, one through the front, and one through the rear gaps. This flux produces north and south poles, as shown. By turning the left shunt in, some of the flux is forced through the armature, making it a north pole. Thus, reducing the left hand rear gap will produce a force tending to pull the armature to the right. Similarly, reducing the right hand gap will make the armature a south pole and produce a force tending to pull the armature to the left.

The alarm unit contacts of the sending and receiving end relays are biased to move to the left when the relay is deenergized. The PMG-13 or PM-13 and PM-23 trip unit contact is biased to move to the left when the relay is deenergized. The PM-5 is adjusted so that the moving contact floats when the relay is deenergized.

CHARACTERISTICS

Nominal Calibration Values

Nominal current values to close contacts are listed in Tables IV and V.

Voltage Ratings

Supply voltage ratings of the monitoring source

relays to obtain continuous monitoring current are as follows:

DC - 48, 125, and 250 volts

AC - 120 volts, 60 cycles (Primary taps 100, 110, 120 & 130)

Voltage impressed on the pilot wire is a nominal 20 volts for monitoring, and 48 volts for tripping.

Supply voltage ratings to obtain remote tripping are: 48, 125, and 250 volts d-c.

Coil Resistance (each winding)

Alarm coil (1)	
two terminal line	1050-1250 ohms
three terminal line	700-900 ohms
Alarm coil (2)	2200-2600 ohms
Trip coil (3)	1800-2200 ohms
Ground Alarm coil (5)	5200-5800 ohms

PM-4 and PM-23 Resistance

Nominal PM-4 and PM-23 total resistance when adjusted for service is 20,000 ohms less pilot wire loop resistance at 1 ma.

PMA, PMA-1 and AC PMG-13, PM-13 Burden

0.5 VA at tap voltage	-	2-terminal line relay
1.0 VA at tap voltage	-	3-terminal line relay

Rectifiers

Approximate forward resistance - 560 ohms at 1 ma
300 ohms at 2 ma

Rating

Continuous forward
current - amperes - 1

Continuous back
voltage-rms volts - 200

Remote Tripping

Remote trip resistors are listed in Table II and III for 48, 125, and 250 volts d-c.

The relays have sufficient thermal capacity to withstand 20 MA d-c continuously when remote tripping. Nominal trip currents in the tripping relays are 5.0 MA d-c with 48, 125, and 250 volts d-c supply and a 2000-ohm pilot wire.

TABLE II

**PMA, PMA-1, PMD, AND PMD-1 APPLICATIONS
EXTERNAL RESISTORS FOR D.C. REMOTE TRIPPING
(2 REQUIRED PER STATION)**

# LINE TERMINALS	D.C. VOLTAGE	STATION A PMA or PMA-1	STATION A PMD or PMD-1	STATION B PM-2 & PM-3 or PM-23 or PM-4	STATION C PM-2 & PM-3 or PM-23 or PM-4	TO OPERATE
2	48	200	200	—	—	PM-23 or PM-3
	125	3550	3550	—	—	"
	250	9300	9300	—	—	"
3	48	200	200	—	—	"
	125	2000	2000	—	—	"
	250	5600	5600	—	—	"

TABLE IIIA

**PMG-13 AND PM-13 (D.C. SUPPLY) APPLICATIONS
RESISTORS FOR D.C. REMOTE TRIPPING
(2 REQUIRED PER STATION)**

# LINE TERMINALS	D.C. VOLTAGE	STATION A PMG-13 or PM-13	STATION B PM-2 & PM-3 or PM-23 or PM-4	STATION C PM-2 & PM-3 or PM-23 or PM-4	TO OPERATE
2	48	200 †	200	—	PMG-13 or PM-13 and PM-23 or PM-3
	125	2120 †	2120	—	"
	250	5600 †	5600	—	"
3	48	200 †	200	200	"
	125	1500 †	1500	1500	"
	250	4000 †	4000	4000	"

† Mounted in Relay

TABLE IIIB

**PMG-13 AND PM-13 (A.C. SUPPLY) APPLICATIONS
(2 REQUIRED PER STATION)
RESISTORS FOR D.C. REMOTE TRIPPING**

# LINE TERMINALS	D.C. VOLTAGE	STATION A PMG-13 or PM-13	STATION B PM-2 & PM-3 or PM-23 or PM-4	STATION C PM-2 & PM-3 or PM-23 or PM-4	TO OPERATE
2	48	200 †	200	—	PMG-13 or PM-13 and PM-23 or PM-3
	125	2120 †	2120	—	"
	250	5600 †	5600	—	"
3	48	200 †	200	200	"
	125	1500 †	1500	1500	"
	250	4000 †	4000	4000	"

† Mounted in Relay

TABLE IV

NOMINAL CALIBRATION VALUES – TWO TERMINAL LINES

RELAY	LOW CURRENT ALARM ¹	HIGH CURRENT ALARM ²	TRIP
PMA or PMA-1	0.7 ma	1.3 ma	—
PMD or PMD-1	0.7	1.3	—
PM-5 †	—	±0.3	—
PMG-13 or PM-13	0.7 ††	1.3 ††	14 V.
PM-23 or PM-2 & PM-3 †	0.7	—	14 V.

† Same relay as for three-terminal lines

†† These are pilot-wire current values

1—Left-hand contacts, front view.

2—Right-hand contacts, front view.

TABLE V

NOMINAL CALIBRATION VALUES – THREE TERMINAL LINES

RELAY	LOW CURRENT ALARM	HIGH CURRENT ALARM	TRIP
PMA or PMA-1 •	1.7 ma	2.3 ma	—
PMD or PMD-1	1.7	2.3	—
PM-5 †	—	±0.3	—
PMG-13 or PM-13	1.7 ††	2.3 ††	14 V.
PM-23 or PM-2 & PM-3 †	0.7	—	14 V.

† Same relay as for two-terminal lines

†† These are pilot-wire current values

Trip Circuit

The main contacts will safely close 30 amperes at 250 volts d-c and the seal-in contacts of the indicating contactor switch will safely carry this current long enough to trip a circuit breaker.

The indicating contactor switch has two taps that provide a pickup setting of 0.2 or 2 amperes. To change taps requires connecting the lead located in front of the tap block to the desired setting by means of a screw connection.

Trip Circuit Constant

Indicating Contactor Switch (ICS)

0.2 ampere tap 6.5 ohms d-c resistance

2.0 ampere tap 0.15 ohms d-c resistance

SETTING THE RELAY

Operating units of all relays are adjusted in the factory to the values listed in Tables IV and V to a tolerance of ±5%. No settings are required on these units.

For all 48/125-volt d.c. relays, connect jumpers across resistors as shown on the internal schematics.

PM-4, PM-2, and PM-23 Relays

Adjust the resistors in the PM-4, PM-2, or PM-23 relay or relays to a value of 1 MA d-c with the monitoring circuits connected for service. Use the milliammeter in the PM-23 for this purpose or use a portable milliammeter with a resistance of less than 200 ohms. Where it is not practical on three-terminal lines to adjust both receiving relays simultaneously, set one receiving relay for 18,000 ohms total resistance (including relay coil and resistors) by measurement prior to final adjustment of the other receiving relay. This procedure will minimize the change in monitoring current in the first relay to be adjusted when making the final adjustment of the second relay.

PMA, PMA-1, PMG-13 and PM-13 Relays

Select the transformer tap nearest to expected normal a-c supply voltage. The full wave rectifier is

connected to a secondary transformer tap. Where desired, the output voltage can be raised about 5% by reconnecting across the full secondary winding.

Indicating Contactor Switch

No setting is required on the ICS unit except the selection of the 0.2 or 2.0 ampere tap setting. This selection is made by connecting the lead located in front of the tap block to the desired setting by means of the connecting screw. When the relay energizes a type WL relay switch, or equivalent, use the 0.2 ampere tap.

INSTALLATION

The relays should be mounted on switchboard panels or their equivalent in a location free from dirt, moisture, excessive vibration, and heat. Mount the relay vertically by means of the four mounting holes on the flange for semi-flush mounting or by means of the rear mounting stud or studs for projection mounting. Either a mounting stud or the mounting screws may be utilized for grounding the relay. The electrical connections may be made directly to the terminals by means of screws for steel panel mounting or to the terminal studs furnished with the relay for thick panel mounting. The terminal studs may be easily removed or inserted by locking two nuts on the stud and then turning the proper nut with a wrench.

For detailed FT case information, refer to I.L. 41-076.

Where the potential to ground impressed on the relays can exceed 700 volts, a drainage reactor in conjunction with a KX-642 tube, or the reactor in conjunction with 700 volt carbon-block arresters, is recommended. For details, see Protection of Pilot-Wire Circuits, AIEE Committee Report, paper 58-1190, AIEE Transactions, 1959, Volume 78, Part III B pp. 205-212. Also, see AIEE Special Publication S-117, Applications and Protection of Pilot-Wire Circuits for Protective Relaying, July 1960.

ADJUSTMENTS AND MAINTENANCE

The proper adjustments to insure correct operation of this relay have been made at the factory and should not be disturbed after receipt by the customer. If the adjustments have been changed, the relay taken apart for repairs, or if it is desired to check the adjustments at regular maintenance periods, the instructions in the succeeding sections should be followed.

Acceptance Tests

The following tests are recommended when the relay is received from the factory. If the relay does not perform as specified below, the relay either is not properly calibrated or it contains a defect.

Indicating Contactor Switch (ICS)

Close the contact of the tripping unit and pass sufficient direct current through the trip circuit to close the contacts of the ICS unit. This value of current should not be greater than the particular ICS tap setting being used (0.2 or 2.0). The indicator target should drop freely.

PMA and PMA-1 Relays

Alarm Unit (1)

Set the primary tap on 120 volts. Connect a variable resistor of approximately 20,000 ohms in series with a low-range d-c milliammeter across terminals 6 and 7 with the instrument positive connected to terminal 7. Apply 120 volts at rated frequency to terminals 4 and 5. Adjust the 20,000-ohm resistor to obtain a current of one ma. d.c. For a three-terminal line relay, use a 10,000-ohm resistor and set the current to 2 ma. d.c. At this value, the moving contact of the alarm or monitoring relay unit (1) should float between the two sets of stationary contacts. In the PMA relay, the ground alarm unit (5) contact should also float. (This contact will also float when the relay is de-energized.) Increase and decrease the one or two-milliamper monitoring current to check the calibration values listed in Tables IV and V.

Ground Unit (5)

Reconnect the 20,000-ohm resistor. For the PMA relay only, short terminals 7 and 3. The contact of the ground alarm unit (5) should close to the right when the relay is energized. Remove the short, and connect it between terminals 6 and 3. The ground alarm unit (5) should close to the left. The action of the monitoring unit (1) contact is of no significance in this simulated pilot-wire ground test. To check the pickup current of the ground detector, first remove the 20,000-ohm resistor from terminals 6 and 7. Connect a 0-1 d.c. milliammeter in series with a variable resistor of about 50,000 ohms between terminals 3 and 6. The ground unit should close its left-hand contact at approximately 0.3 ma. d.c. With the milliammeter and resistor connected between terminals 3 and 7, the right-hand contact should close at 0.3 ma. d.c.

TYPE PM MONITORING RELAYS

PMD and PMD-1 Relays

Alarm and Ground Units

Connect an adjustable 20,000-ohm resistor (or 10,000-ohms for a 3-terminal relay) in series with a d-c milliammeter across terminals 6 and 7 with the instrument positive connected to terminal 7. Apply rated d-c voltage to terminals 8 and 9 with positive on terminal 9. Now check the PMD and PMD-1 relays, following the procedure given in the previous section for the PMA and PMA-1 relays, respectively. Note, however, that terminal 5 of the PMD relay corresponds to terminal 3 of the PMA relay.

PM-2, PM-3, and PM-23 Relays

Alarm Unit (2)

Apply a variable d-c voltage of approximately 20 volts to relay terminals 8 and 9 (terminal 9 positive) of the PM-2 or PM-23 relay. Adjust the voltage to obtain a reading of one ma. on the relay milliammeter. The monitoring polar unit (2) contacts should float. Reduce the current gradually. The monitoring alarm contacts should close at 0.7 ma. d.c. The tripping unit (3) of the PM-23 relay should not move during this test. The milliammeter has been adjusted to read 1 ma. $\pm 5\%$. As a result the pointer may not read zero for a zero current condition.

Tripping Unit (3)

To check the PM-3 relay or the tripping unit of the PM-23 relay, apply the variable d-c voltage in series with an external milliammeter to relay terminals 8 and 9 with terminal 8 positive for the PM-23 relay, or terminal 9 positive for the PM-3 relay. When checking the pickup of the PM-23 trip unit block open the alarm unit contacts (2) so as to remove the shunt resistor from around the trip coil (3).

The tripping relay unit (3) should pick up with positive action at 14 volts d.c. and should drop out at approximately 10 volts. The alarm unit of the PM-23 relay will not operate during this test.

PM-4 Relay

This device is simply a set of resistors and a diode to connect into the pilot-wire circuit to provide a path for the monitoring current. The resistors can be checked with an ohmmeter, and the diode can be checked either with an ohmmeter, or as explained in the section entitled "Rectifier Check" under "Routine Maintenance". If an ohmmeter is used, the difference in forward and reverse resistance readings obtained will be dependent on the current flowing through the diode.

PM-5 Relay

Apply 5 volts d.c. in series with a 0-1 d.c. milliammeter and a 20,000-ohm variable resistor to terminals 6 and 7 with positive on terminal 6. The left-hand contact should close at approximately 0.3 ma. Now apply the same circuit to terminals 8 and 9 with positive on terminal 9. The right-hand contact should close at approximately 0.3 ma.

PM 13 Relays - A.C. and D.C.

Alarm Unit (1)

Connect a variable 20,000-ohm resistor (10,000 ohms for a 3-terminal-line relay) in series with a d-c milliammeter across terminals 8 and 9 with the instrument positive on terminal 9. For the a-c relay, set the primary tap on 120 volts. Now apply the rated supply voltage to terminals 4 and 5. This will be 48, 125, or 250 volts d.c., or 120 volts a.c. as indicated on the relay nameplate. Adjust the variable resistor to obtain a current of one ma. for a 2-terminal line relay, or 2 ma. for a 3-terminal relay. At this value, the moving contacts of the alarm or monitoring (1) relay unit (the upper polar unit) should float between the two sets of stationary contacts. Increase and decrease the one or 2 ma. monitoring current to check the calibration values listed in Tables IV and V.

Tripping Unit (3)

To check the operation of the tripping unit 3 (the lower polar unit), apply a d.c. potential across terminals 16 (positive) and 20 (negative). The tripping polar unit should pick up at 14 volts, and should drop out at approximately 10 volts. The resistance of the series dropping resistors for transferred tripping (listed in Tables III A and III B) can be checked with an ohmmeter. The circuit location of these resistors can readily be seen from the external schematic, Figure 27.

PMG-13 Relays - A.C. and D.C.

Alarm and Tripping Units

Follow the procedure given in the previous section for the a-c. and d-c. PM-13 relays.

Ground Unit (5)

Connect the 20,000-ohm (or 10,000-ohm) resistor and milliammeter across terminals 8 and 9. With rated voltage applied and one ma. (or 2 ma.) flowing, successively short circuit terminals 3 and 8, then 3 and 9. The ground alarm unit 5 (lower polar unit) should move first to the left, then to the right. To check the pickup current of the ground detector, first remove the 20,000-ohm resistor from terminals 8 and 9. Connect a 0-1 d.c. milliammeter in series

with a variable resistor of about 50,000 ohms between terminals 3 and 8. The left-hand contact should close at approximately 0.3 ma. d.c. With the milliammeter resistor connected, between terminals 3 and 9, the right-hand contact should close at 0.3 ma. d.c. The external schematic diagrams for these relays are shown in Figure 23 and 25.

Routine Maintenance

CAUTION - Do not make any performance check, calibration tests, or adjustments while the PM relays are energized or connected to the pilot wires, to prevent the possibility of inadvertently causing a break operation. The PM relays may be removed from service for testing, without jeopardizing HCB relay protection, providing that the connections between the 10-mfd capacitor and the HCB insulating transformer are not disturbed.

Contacts

All contacts should be periodically cleaned. A contact burnisher S#182A836H01 is recommended for this purpose. The use of abrasive material for cleaning contacts is not recommended because of the danger of embedding small particles in the face of the soft silver and thus impairing the contact.

Operational Check

In addition to cleaning contacts, it is recommended that an operational check be performed periodically by opening and short-circuiting the pilot wires, as well as grounding them at the relay terminals. **Note:** These pilot-wire faults should not be applied directly to the pilot wires when the HCB relays are in service. It is also recommended that the trip circuits of the PM relays be opened (where tripping is used), to prevent the possibility of inadvertently tripping the associated circuit breaker during testing. If the relays do not perform as expected, and diode failure is suspected, the diode tests described in the following section may be performed.

Rectifier (Diode) Check

If there is suspicion of a rectifier (diode) failure, apply 30 volts d.c. reverse voltage (positive on arrowhead) through a 300-ohm resistance to the diode. Measure the voltage across the diode. If this voltage is not essentially 30 volts, the diode is short-circuited. Now apply 30 volts d.c. in the forward direction through the 300-ohm resistor, and measure the voltage across the resistor. If the voltage is not essentially 30 volts, the diode may have a high forward resistance. If the voltage is zero, the diode is open-circuited.

Calibration

If the relay has been dismantled or the calibration has been disturbed, use the following procedure for calibration.

With the permanent magnet removed, see that the moving armature floats in the central area of the air-gap between the poles of the polar unit frame. If necessary, loosen the core screw in the center rear of the unit and shift the core and contact assembly until the armature floats. (This can best be done with the polar unit removed from the relay.) Then retighten the core screw and replace the permanent magnet with the dimple (north pole) on the magnet to the left when viewed from the front.

Polar Units-General

The following mechanical adjustments are given as a guide, and some deviation from them may be necessary to obtain proper electrical calibration.

Magnetic Shunt Adjustment

The sensitivity of the polar unit is adjusted by means of two magnetic, screw-type shunts at the rear of the unit, as shown in Fig. 1. These shunt screws are held in proper adjustment by a flat strip spring across the back of the polar unit frame, so no locking screws are required. Looking at the relay, front view turning out the right-hand shunt to open the right-hand air gap decreases the amount of current required to close the right-hand contact. Conversely, drawing out the left-hand shunt increases the amount of current required to close the right-hand contact, or decreases the amount of current required to close the left-hand contact (with the proper direction of current flow). Also, if a relay trips to the right at the proper current, the dropout current can be raised by turning in the right-hand shunt. The two shunt-screw adjustments are not independent, however, and a certain amount of trimming adjustment of both shunt screws is generally necessary to obtain the desired pickup and dropout calibration.

In general, the farther out the two shunt screws are turned, the greater the toggle action will be, and as a result, the lower the dropout current. For the tripping units (3) of the PM-3, PM-13, and PM-23 relays, toggle action is desirable, with a dropout current around 75 percent of the pickup current. For the monitoring alarm relay units, toggle action is not desired. Instead, the armature is adjusted to float between the pole faces at a given current (1 or 2

TYPE PM MONITORING RELAYS

The following chart indicates the units present in each relay.

FUNCTION AND UNIT	PMA PMD	PMA-1 PMD-1	PM2	PM3	PM4	PM5	PM13	PMG13	PM23
Alarm for p.w. open, short or reversal (1) (2)	X	X	X				X	X	X
Transfer - Trip Unit (3)				X			X	X	X
Alarm for p.w. ground (5)	X					X		X	
D.C. Path for Monitoring Current					X				

ma.), and to move gradually toward the high or low-current alarm as the coil current is increased or decreased. Similarly, the floating adjustment of the armature of the ground alarm unit (5) requires that both shunt screws be turned in relatively far. Then the armature will move gradually to the left or right as the current through the two #5 coils is unbalanced.

The electrical calibration of the polar unit is also affected by the contact adjustment as this changes the position of the polar unit armature. Do not change the contact adjustment without rechecking the electrical calibration.

Contact Adjustment - All Relays

For all monitoring alarm units, designated (1) or (2), turn in all the stationary contact and contact stop screws until they just touch the moving contact. Advance the screws to hold the armature in the central portion of the magnetic air gap between the two pole faces. (The stationary contact screws have a round silver contact face; the stop screws do not have this silver facing.) Now back off all the contact and contact stop screws one full turn. This will give a total contact travel of 0.050 inch. When the relay is properly calibrated, some touch-up adjustment may be necessary so that double contacts will both close at the same current value. The contact gap between the floating moving contact and the right-hand or left-hand stationary contacts or contact stops will be approximately 0.025 inch when the relay is in operation.

For the tripping (3) units of the PM-3, PM-13, PMG-13, and PM-23 relays, adjust the contacts as described in the previous paragraph, except back off the contact and stop screws one-half turn each to

give a total moving contact travel of approximately 0.025 inch. In operation of the tripping unit, the moving contact will normally rest against the contact stop screws, and will pick up only for a transferred-tripping operation.

For the pilot-wire ground alarm unit (5) of the PMA, PMD, PM5, and PMG-13 relays, follow the same general procedure except back off both stationary contact screws two turns each. This will give a contact gap of 0.050 on each side of the moving contact when it is its normal central position.

Electrical Calibration - All Relays

In the following sections, the calibration instructions are given for the polar unit which performs a certain function, such as alarm (1) or (2), ground (5), or trip (3), rather than giving calibration instructions for each complete relay. In this way, considerable duplication of instructions has been eliminated.

Alarm Unit (1)

Connect the relay as described under Acceptance Tests for the particular relay involved. Screw the two magnetic shunts all the way in, then back them out five turns each. With the relay energized at rated voltage, set the monitoring current at 1.3 or 2.3 ma. d.c. for 2 or 3-terminal relay respectively, by adjusting the external resistor. If the relay does not close its right-hand contact, turn in the left shunt screw until the right-hand contact just closes. If the right-hand contact is closed at 1.3 ma., turn in the right shunt until a point is reached when the right-hand contact is just closed at 1.3 ma.

Now drop the current to 0.7 ma. and adjust the opposite shunt until the left-hand contact just closes

at 0.7 ma. d.c. At 1.0 ma. d.c., the moving contact should float half way between the two sets of stationary contacts with a 0.025-inch gap on each side. Recheck the high and low current calibration several times, touching up the shunt adjustments as required to obtain the desired calibration.

Polarization Check

For all the source relays, which are listed below, make the following additional calibration check:

- PMA
- PMA-1
- PMD
- PMD-1
- PM-13 (a.c. and d.c.)
- PMG-13 (a.c. and d.c.)

After calibration as described in the previous sections, connect a 20,000 ohm resistor (or 10,000 ohms for 3-terminal applications) across the output terminals, and energize the relay at its rated supply voltage. With these connections, approximately one (or two) milliamperes d.c. will flow through the monitor relay coils and external resistor, thus representing normal operating conditions.

Now momentarily (one second or so) apply 48 volts d.c. directly to the pilot-wire terminals of the relay, as indicated in the following table.

Relay	Terminals for Momentary Application of 48 V. d.c.	
	POS.	NEG.
PMA, PMA-1 } PMD, PMD-1 }	6	7
PM-13 (a.c. or d.c.) } PMG-13 (a.c. or d.c.) }	8	9

After momentary application of the transfer-trip voltage as just explained, recheck the calibration of the monitoring alarm unit (1). If it has changed, make necessary trimming adjustments of the shunt screws until there is no change in calibrating of the alarm unit (1) after the transfer-trip voltage has been applied. The purpose of this test is to compensate for the small residual magnetism in the relay unit. The ground alarm unit (5) will not be affected by this test as the ampere-turns of the two windings cancel each other.

Alarm Unit (2)

For the alarm unit of the PM-2 or PM-23 relays, adjust the shunts so that the relay moving contact

floats at one ma. d.c., and closes the left-hand contact at 0.7 ma. d.c. The moving contact should float midway between the contact and contact stop at 1.0 ma. d.c. There is no high-current calibration for this relay unit.

Now apply 48 volts d.c. momentarily (one second or so) across the alarm unit coil-circuit terminals in a direction to operate the alarm relay. Then recheck the alarm unit calibration. If there is any change, touch up the shunt adjustments until there is no change in calibration after 48 v. d.c. has been applied.

Tripping Unit (3)

To calibrate the tripping unit of the PM-3, PM-13, PMG-13, or PM-23 relays apply a d.c. voltage as explained below, to the following relay terminals:

Relays	D.C.	Voltage
	Pos.	Neg.
PM-3	9	8
PM-13 (a.c. or d.c.)	16	20
PMG-13 (a.c. or d.c.)	8	9
PM-23	8	9

Momentarily (one second or so) apply 48 volts d.c. to the terminals shown in the chart. Then starting with both shunts all the way in, turn out the right-hand shunt screw until the relay closes its right-hand trip contact at 14 volts d.c. (This will give approximately 2 ma. through the relay coil.) Now draw out the left-hand shunt until the relay resets with toggle action (not gradually) at not less than 10 volts d.c. When the calibration is approximately correct, again apply 48 volts d.c. to the indicated terminals, then recheck the pickup and dropout voltage, making any necessary trimming adjustments of the shunts. When the relay is properly adjusted, the application of 48 volts d.c. will not change the pickup or dropout voltage points. The relay should trip and reset with toggle action in this application. This will require both shunt screws to be withdrawn farther than for floating action.

Ground Alarm Unit (5)

For the PM-5 relay, turn both shunt screws all the way in, then back them out five turns each. Pass a current of 0.3 ma. d.c. in terminal 6 and out terminal 7. Following the same general procedure as described previously in the section entitled "Alarm Unit (1)," adjust the shunt screws so that the left-hand contact closes at 0.3 ma. Now pass 0.3 ma. d.c.

TYPE PM MONITORING RELAYS

in terminal 9 and out terminal 8, and adjust for closing of the right-hand contact at 0.3 ma. Recheck both pickup points several times, and make trimming adjustments of both shunts as required to obtain contact closing at 0.3 ma. d.c. in each direction.

For the ground unit (5) of the PMA, PMD, and PMG-13 relays, connect a variable resistance of about 50,000 ohms in series with a 0-1 d.c. milliammeter between the terminals indicated in the following table:

Turn the shunts all the way in, then back them out five turns each. With the relay connected as shown in the left-hand column of the table, apply rated voltage to the relay and adjust the 50,000-ohm resistor for 0.3 ma. d.c. Now following the procedure in the previous paragraph for the PM-5 relay, adjust the shunts until the left-hand contact closes at 0.3 ma. d.c. Change the connections as indicated in the right-hand column, and adjust the opposite shunt until the right-hand contact closes. Recheck back and forth several times and make necessary trimming adjustments to obtain pickup at 0.3 ma. In each direction. The armature will move gradually as the

current is changed for this relay unit.

ICS Unit

Close the main relay tripping contact circuit with a jumper connected directly across the contact terminals of the polar unit. Pass sufficient direct current through the relay trip circuit to close the contacts of the ICS unit. This value of current should not be greater than the ICS tap setting being used (0.2 or 2.0). The indicator target should drop freely. The contact gap should be approximately 0.047 inch between the bridging moving contact and the adjustable stationary contacts. The bridging moving contact should touch both stationary contacts simultaneously.

RENEWAL PARTS

Repair work can be done most satisfactorily at the factory. However, interchangeable parts can be furnished to the customers who are equipped for doing repair work. When ordering parts, always give the complete nameplate data.

Ground Alarm (5) Calibration		
Relay	<u>Relay Terminals</u>	
	L.H. Contact Check	R.H. Contact Check
PMA	3 ⁺ and 6	3 and 7 ⁺
PMD	5 ⁺ and 6	5 and 7 ⁺
PMG-13	3 ⁺ and 8	3 and 9 ⁺

+ Milliammeter positive to this terminal

INDEX TO FIGURES

INTERNAL SCHEMATICS

FIG. NO.		PAGE NO.
1	Polar Unit Permanent Magnet Flux Paths	2
2	PMA Relay - AC supply - two terminal line	14
3	PMA-1 Relay - AC supply - two terminal line	14
4	PMA Relay - AC supply - three terminal line	14
5	PMA-1 Relay - AC supply - three terminal line	14
6	PMD Relay - DC supply - two terminal line	15
7	PMD-1 Relay - DC supply - two terminal line	15
8	PMD Relay - DC supply - three terminal line	15
9	PMD-1 Relay - DC supply - three terminal line	15
10	PM-2 relay in FT21 case	16
11	PM-3 relay in FT11 case	16
12	PM-4 relay (auxiliary unit)	16
13	PM-5 ground detector relay	16
14	PM-23 relay in FT21 case	17
15	PM-13 Relay - DC supply - two terminal line	17
16	PM-13 Relay - DC supply - three terminal line	17
17	PM-13 Relay - AC supply - two or three terminal line	17
18	PMG-13 Relay - DC supply - two terminal line	18
19	PMG-13 Relay - DC supply - three terminal line	18
20	PMG-13 Relay - AC supply - two or three terminal line	18

EXTERNAL SCHEMATICS

21	PMD relay with PM-23 or PM-4, two terminal line	19
22	PMA relay with PM-23 or PM-4, two terminal line	19
23	DC type PMG-13 with PM-23 or PM-4, two terminal line	20
24	PMD relay with PM-23 & PM-4, three terminal line	20
25	AC type PMG-13 relay with PM-23, two terminal line	21
26	DC type PM-13 & PM-5 with PM-23 or PM-4, two terminal line	21
27	DC type PM-13 relay with PM-23 or PM-4, two terminal line	22

OUTLINE & DRILLING PLANS

28	10 mfd. capacitor	23
29	Remote trip resistor	23
30	PM-4 projection molded case	23
31	PM-4 semi-flush molded case	23
32	PM-3, PM-5, & PMD-1 in FT11 case	24
33	PM-2, PM-23, PMA-1, & PMD in FT21 case	25
34	PMA in FT31 case	26
35	PM-13 and PMG-13 in FT32 case	27

TYPE PM MONITORING RELAYS

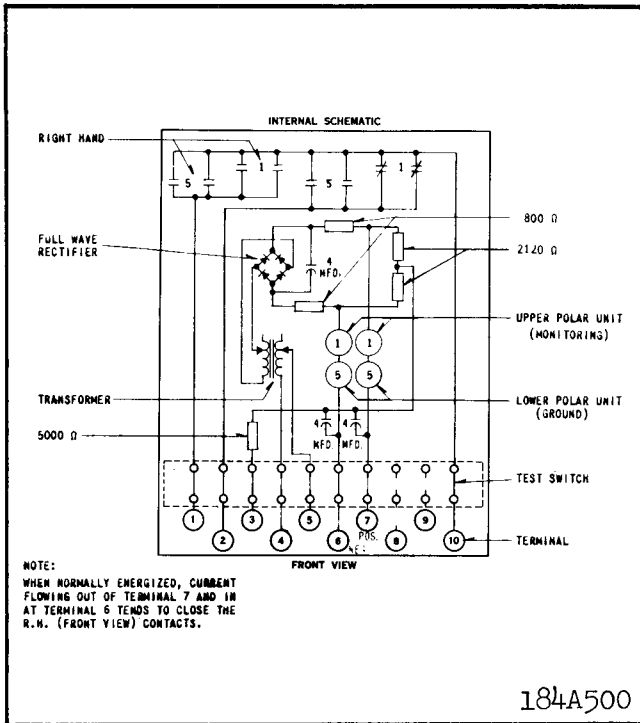

Fig. 2. Internal schematic of the type PMA relay in FT 31 case - 120 volt, 60 cycle supply - For two terminal lines.

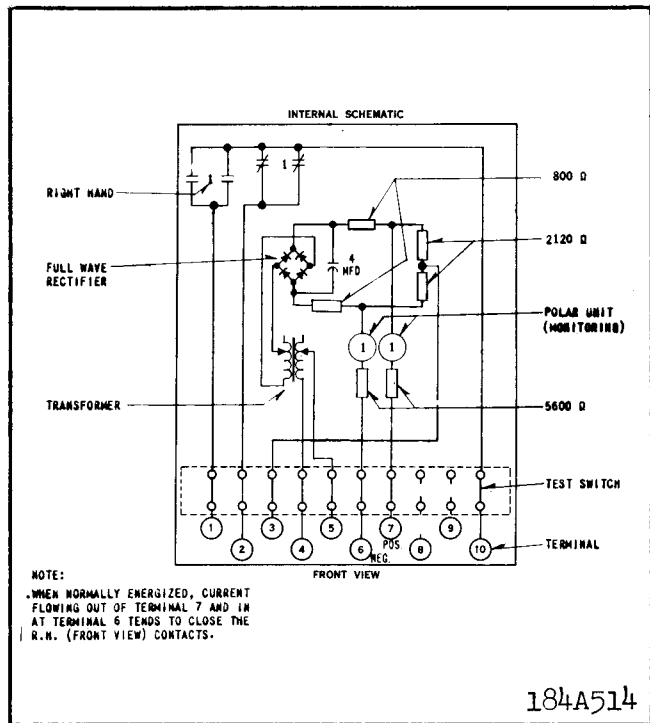

Fig. 3. Internal schematic of type PMA-1 relay in the FT 21 case - 120 volts, 60 cycle supply - For two terminal lines.

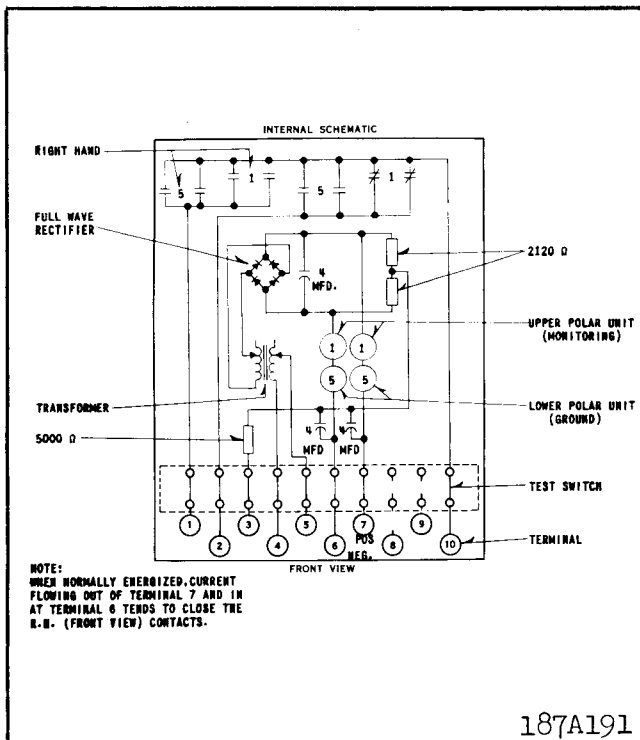

Fig. 4. Internal schematic of type PMA relay in FT 31 case - 120 volt, 60 cycle supply - For three terminal lines.

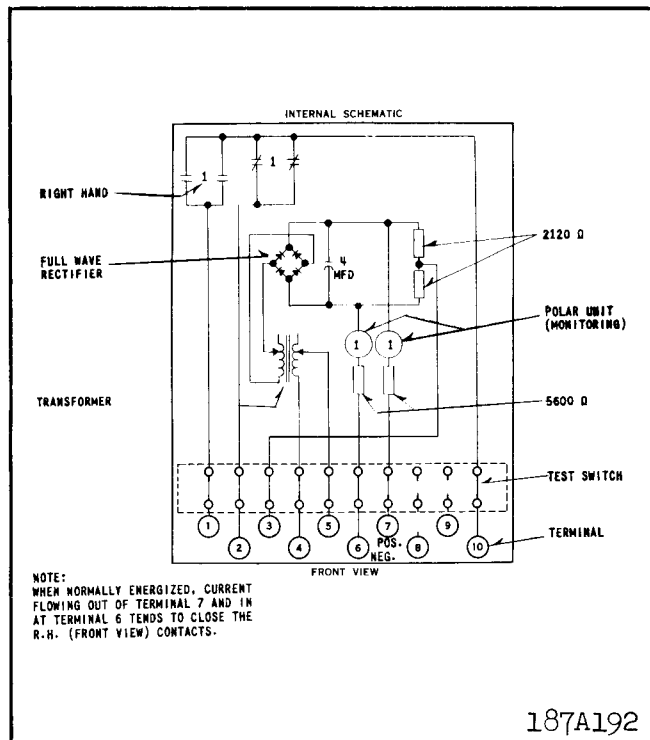

Fig. 5. Internal schematic of type PMA-1 relay in FT 21 case - 120 volt, 60 cycle supply - For three terminal lines.

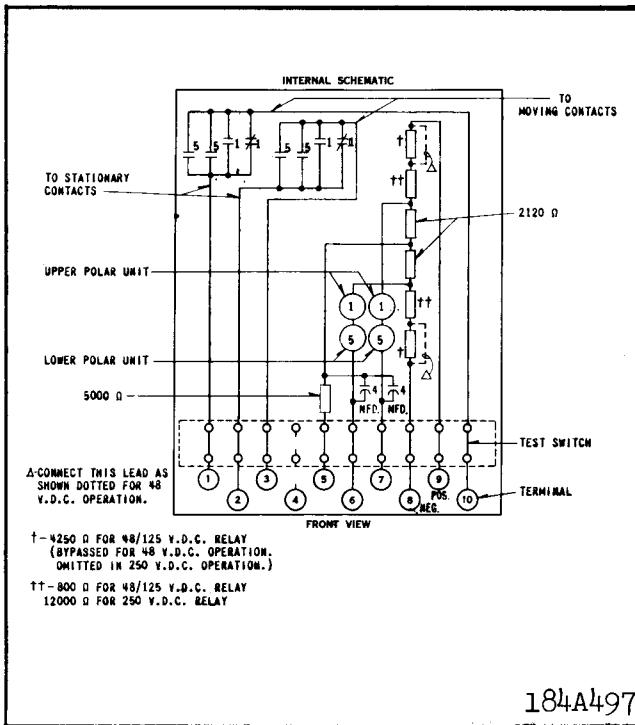

Fig. 6. Internal schematic of the type PMD relay in FT 21 case - DC supply - for two terminal lines.

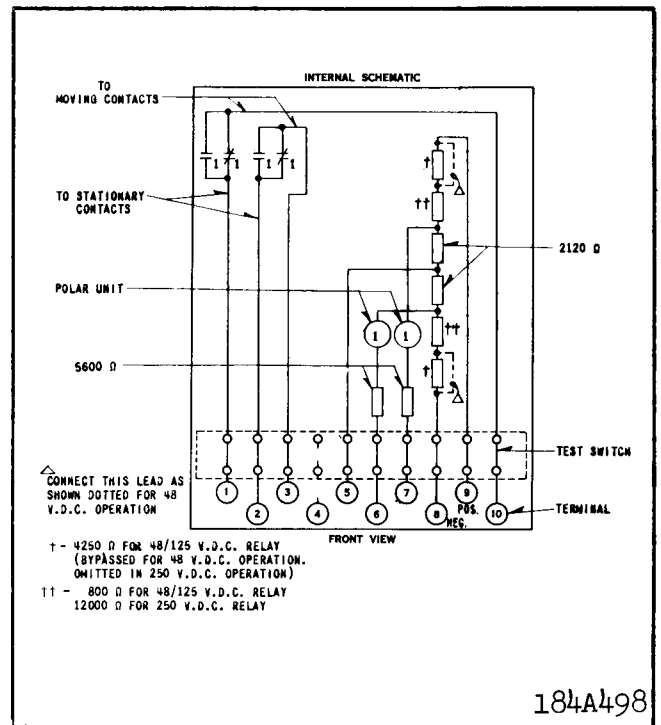

Fig. 7. Internal schematic of the type PMD-1 relay in the FT 11 case - DC supply - For two terminal lines.

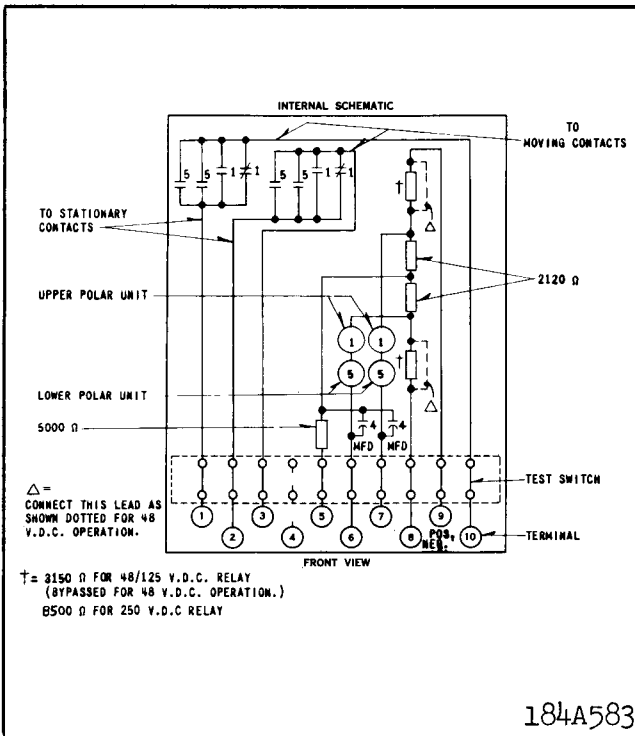

Fig. 8. Internal schematic of the type PMD relay in the FT 21 case - DC supply - For three terminal lines.

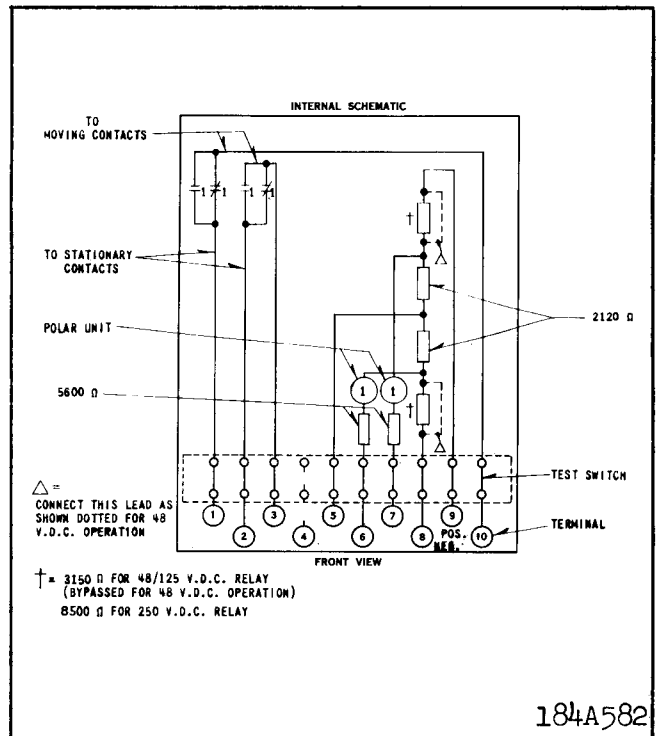

Fig. 9. Internal schematic of the type PMD-1 relay in the FT 11 case - DC supply - For three terminal lines.

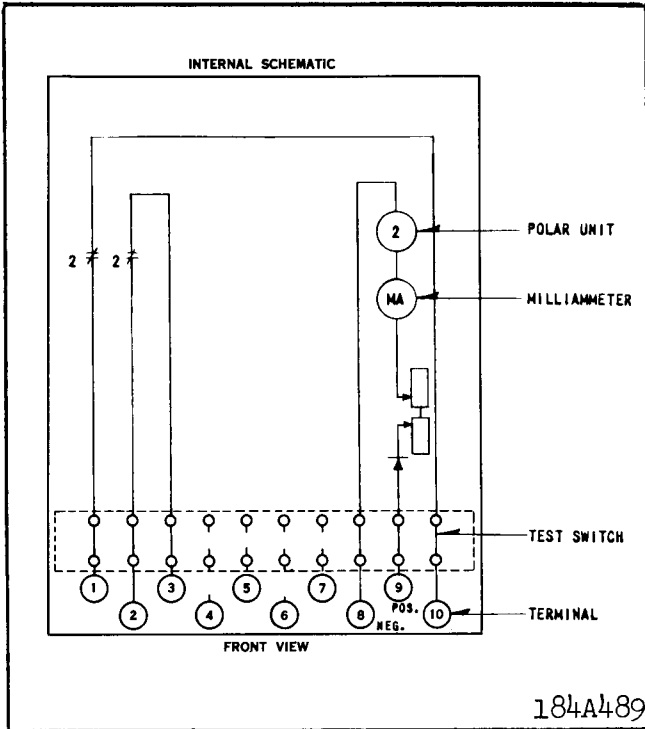

Fig. 10. Internal schematic of the type PM-2 relay in the FT 21 case.

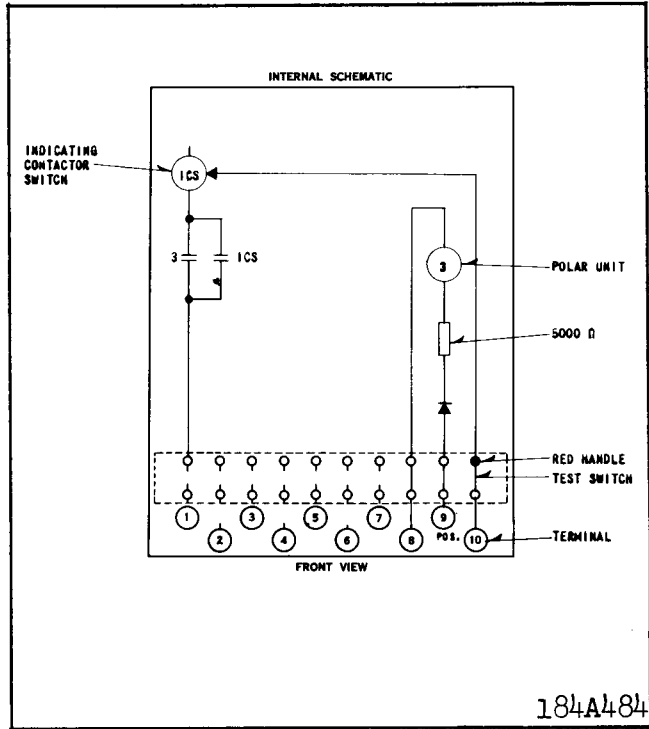

Fig. 11. Internal schematic of the type PM-3 relay in the FT 11 case.

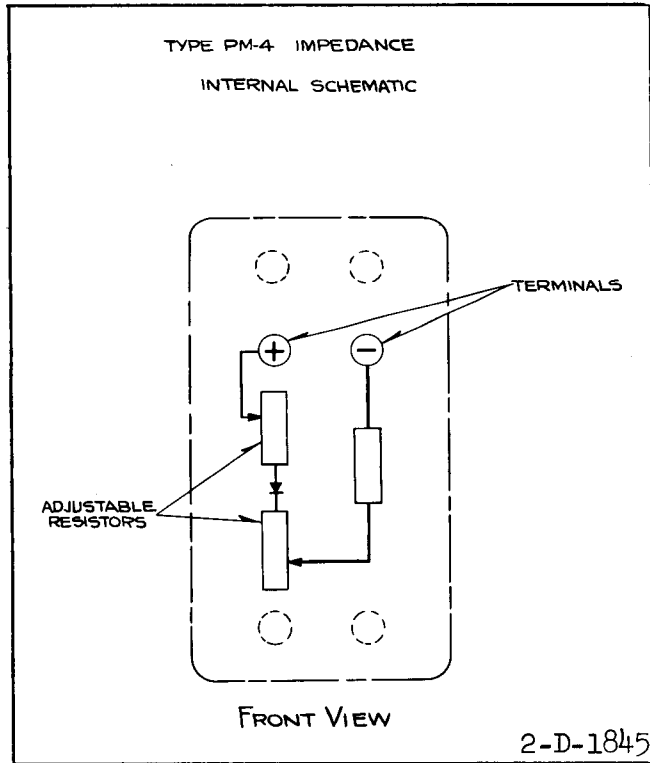

Fig. 12. Internal schematic of the type PM-4 Auxiliary Unit in the small molded case.

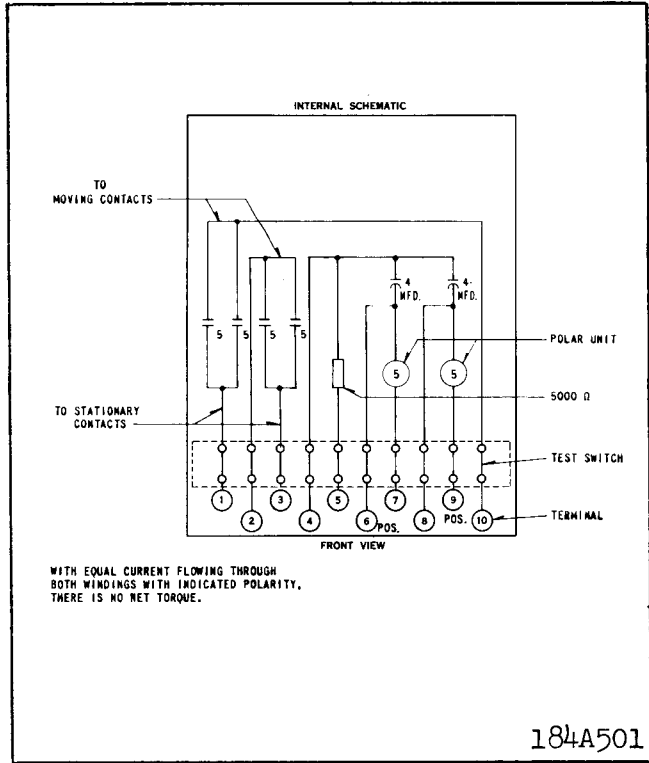

Fig. 13. Internal schematic of the type PM-5 ground detector relay in the FT 11 case.

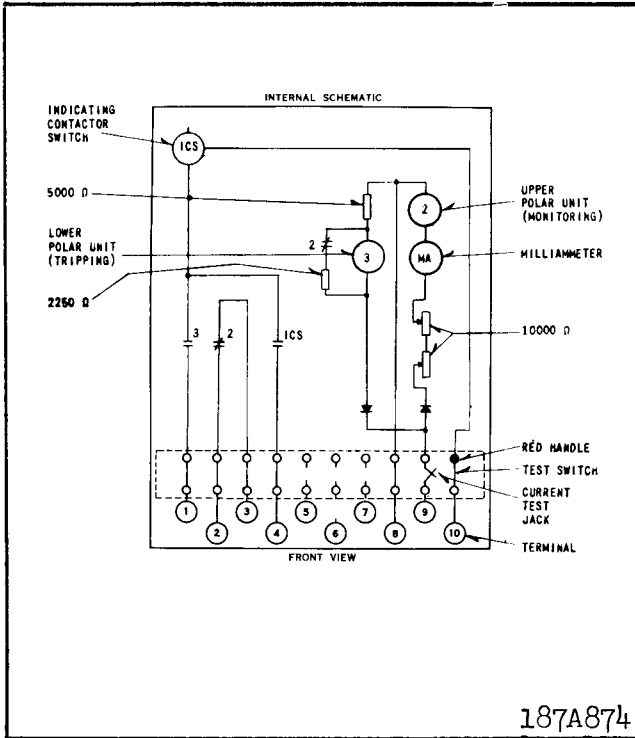

Fig. 14. Internal schematic of the type PM-23 relay in the FT 21 case.

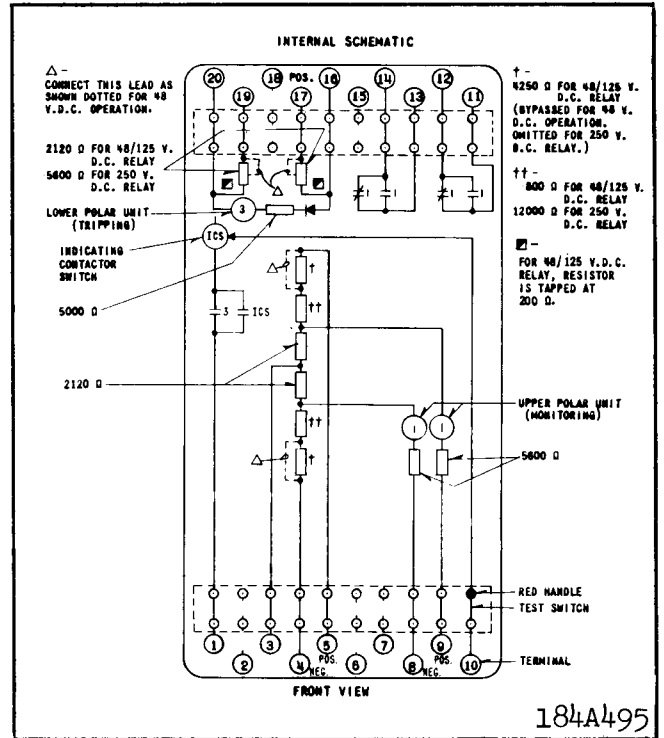

Fig. 15. Internal schematic of the type PM-13 relay in the FT 32 case - DC supply - For two terminal lines.

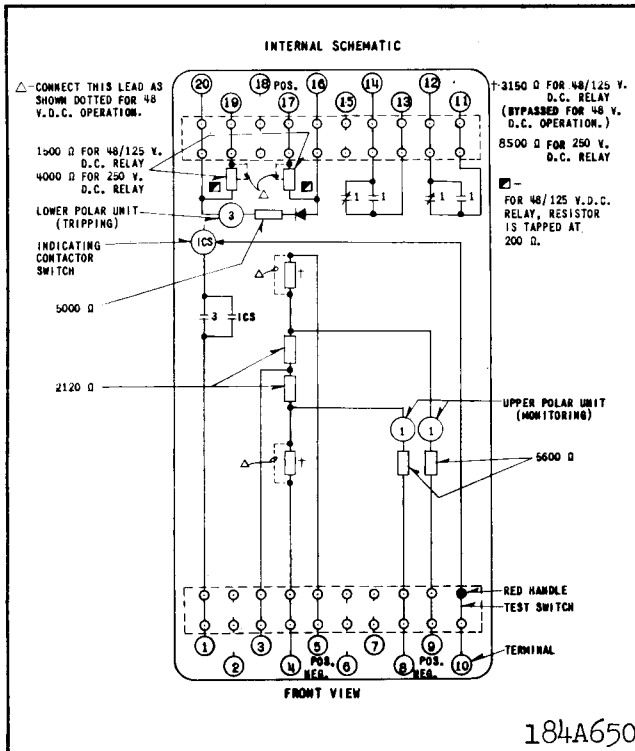

Fig. 16. Internal schematic of the type PM-13 relay in the FT 32 case - DC supply - For three terminal lines.

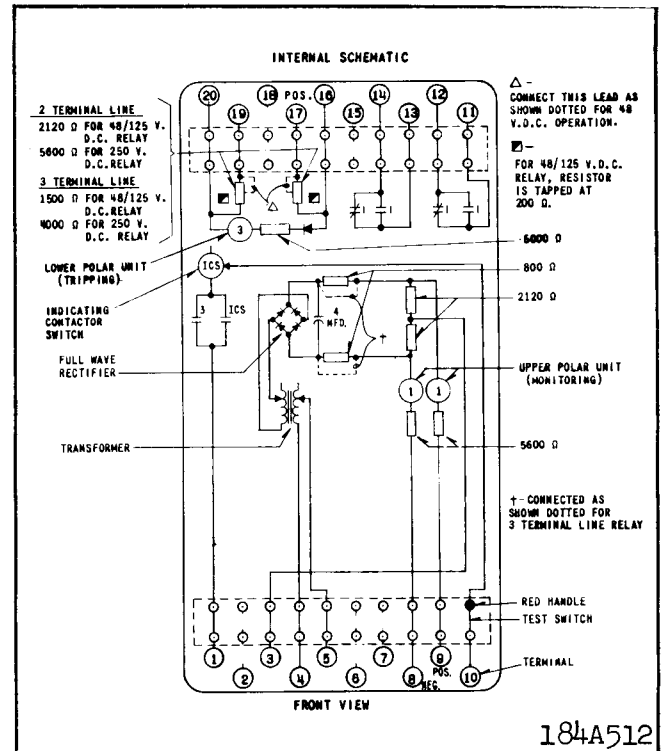

Fig. 17. Internal schematic of the type PM-13 relay in the FT 32 case - 120 volt, 60 cycle supply - For two or three terminal lines.

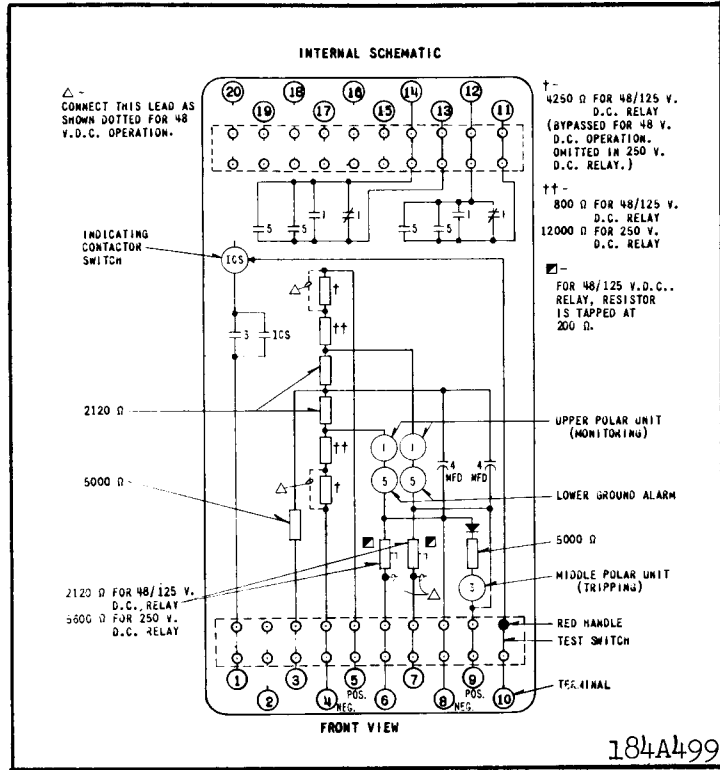

Fig. 18. Internal schematic of the type PMG-13 relay in the FT 32 case - DC supply - For two terminal lines.

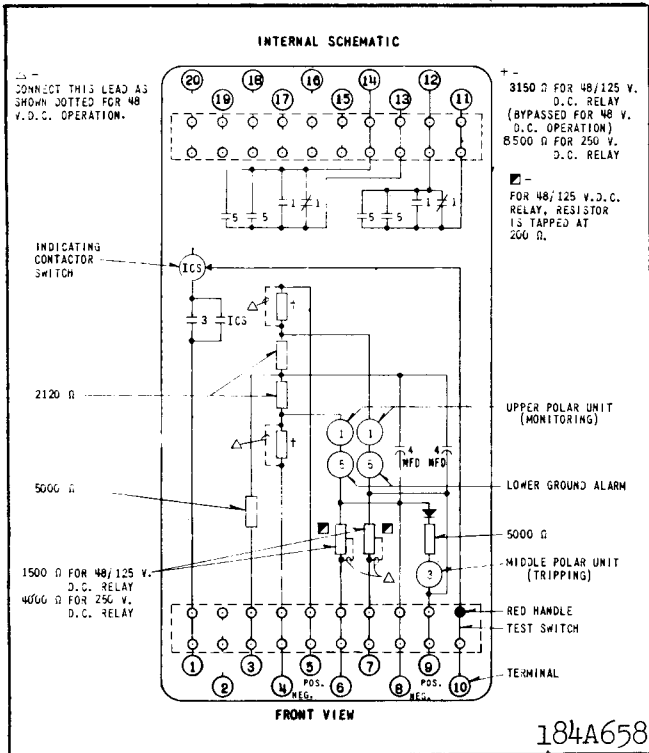

Fig. 19. Internal schematic of the type PMG-13 relay in the FT 32 case - DC supply - For three terminal lines.

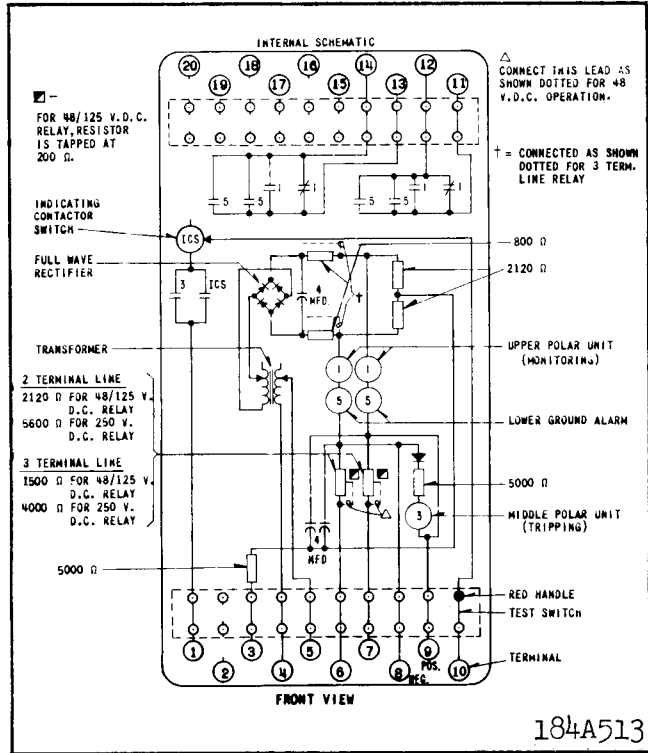
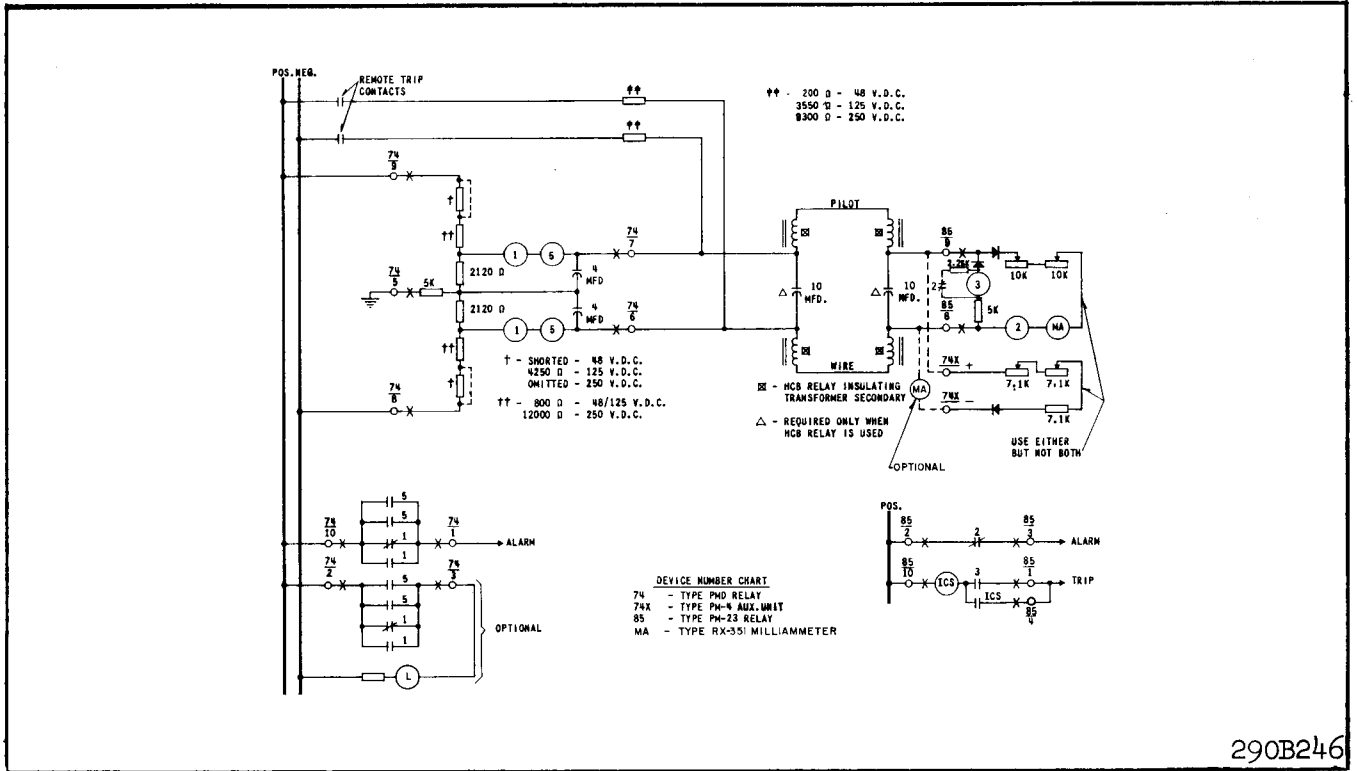
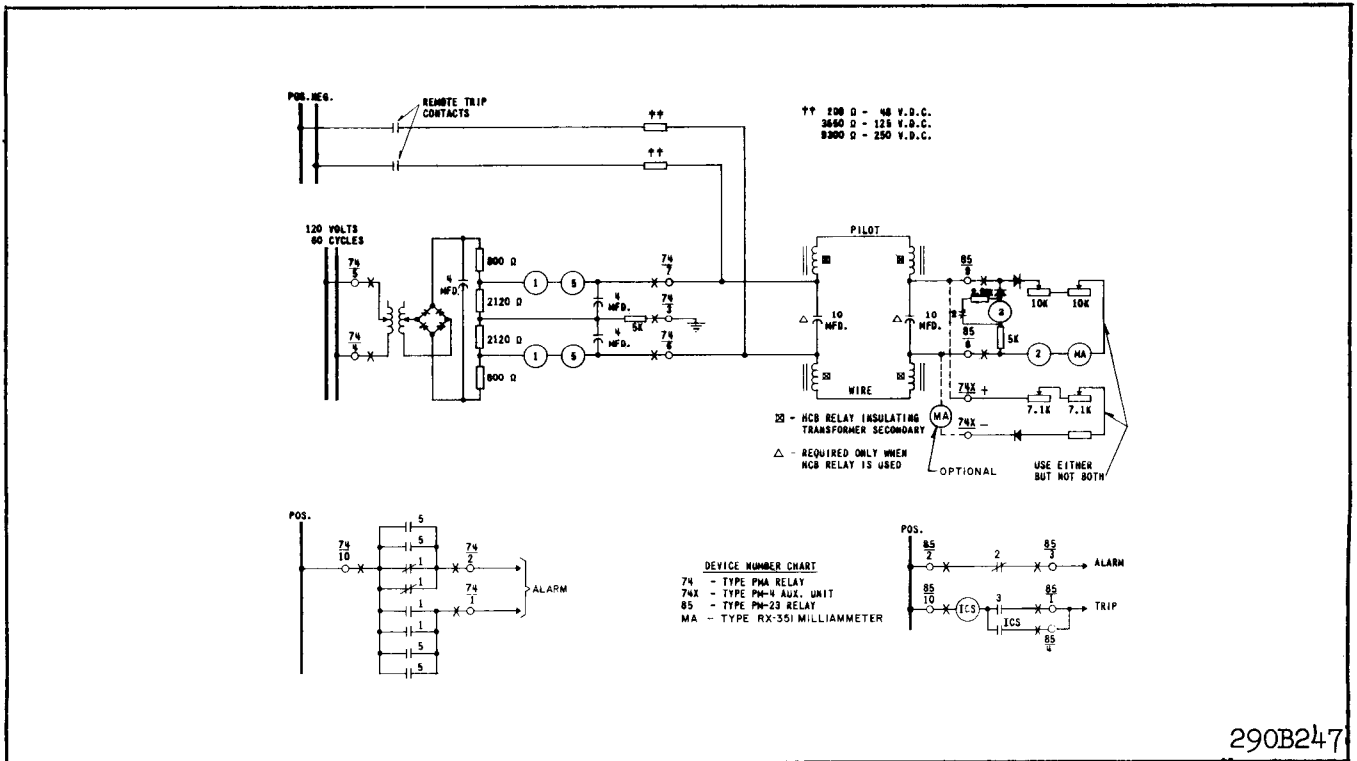

Fig. 20. Internal schematic of the type PMG-13 relay in the FT 32 case - 120 volt, 60 cycle supply - For two or three terminal lines.



290B246

* Fig. 21. External schematic of the type PMD relay with type PM-23 or PM-4 relay - Two terminal lines.



290B247

* Fig. 22. External schematic of the type PMA relay with type PM-23 or PM-4 relay - Two terminal lines.

TYPE PM MONITORING RELAYS

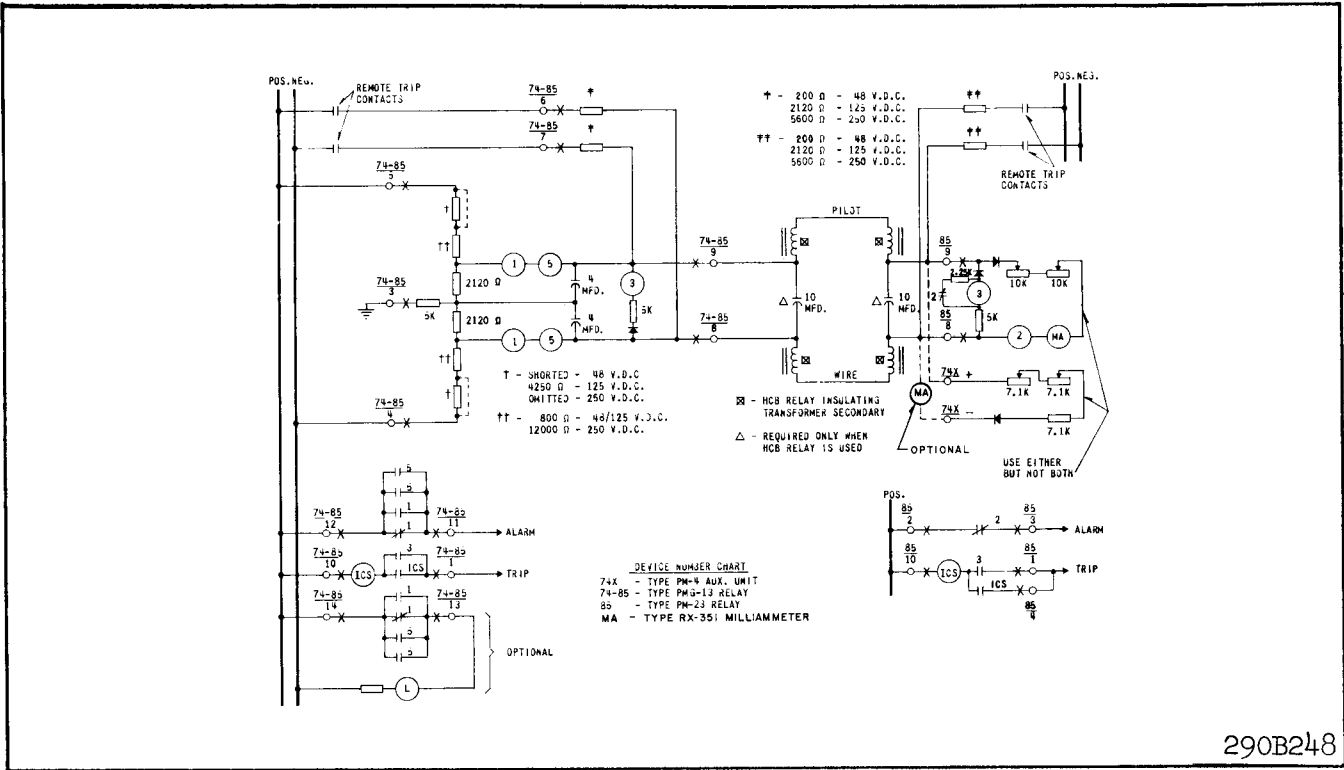

290B248

* Fig. 23. External schematic of the DC type PMG-13 relay with type PM-23 or PM-4 relay – Two terminal lines.

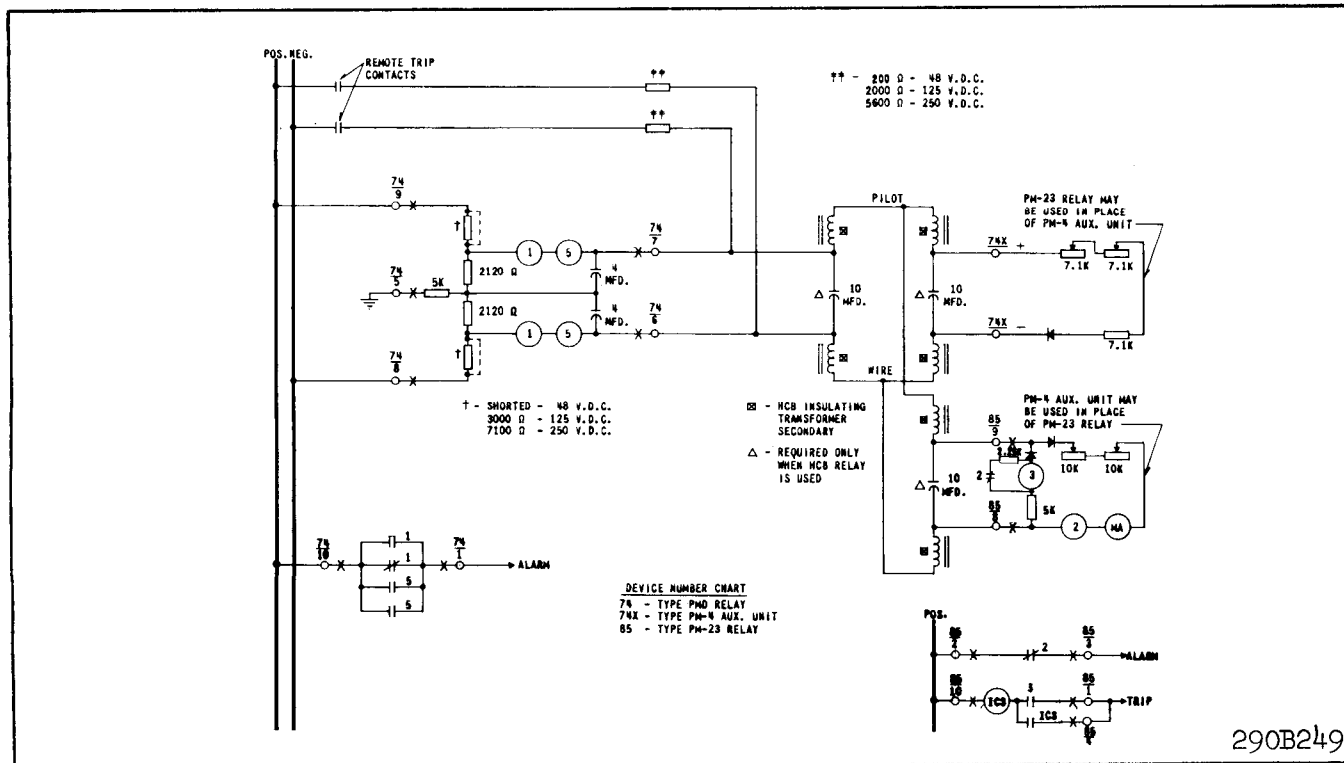

290B249

Fig. 24. External schematic of the type PMD relay with type PM-23 and PM-4 relays – Three terminal lines.

TYPE PM MONITORING RELAYS

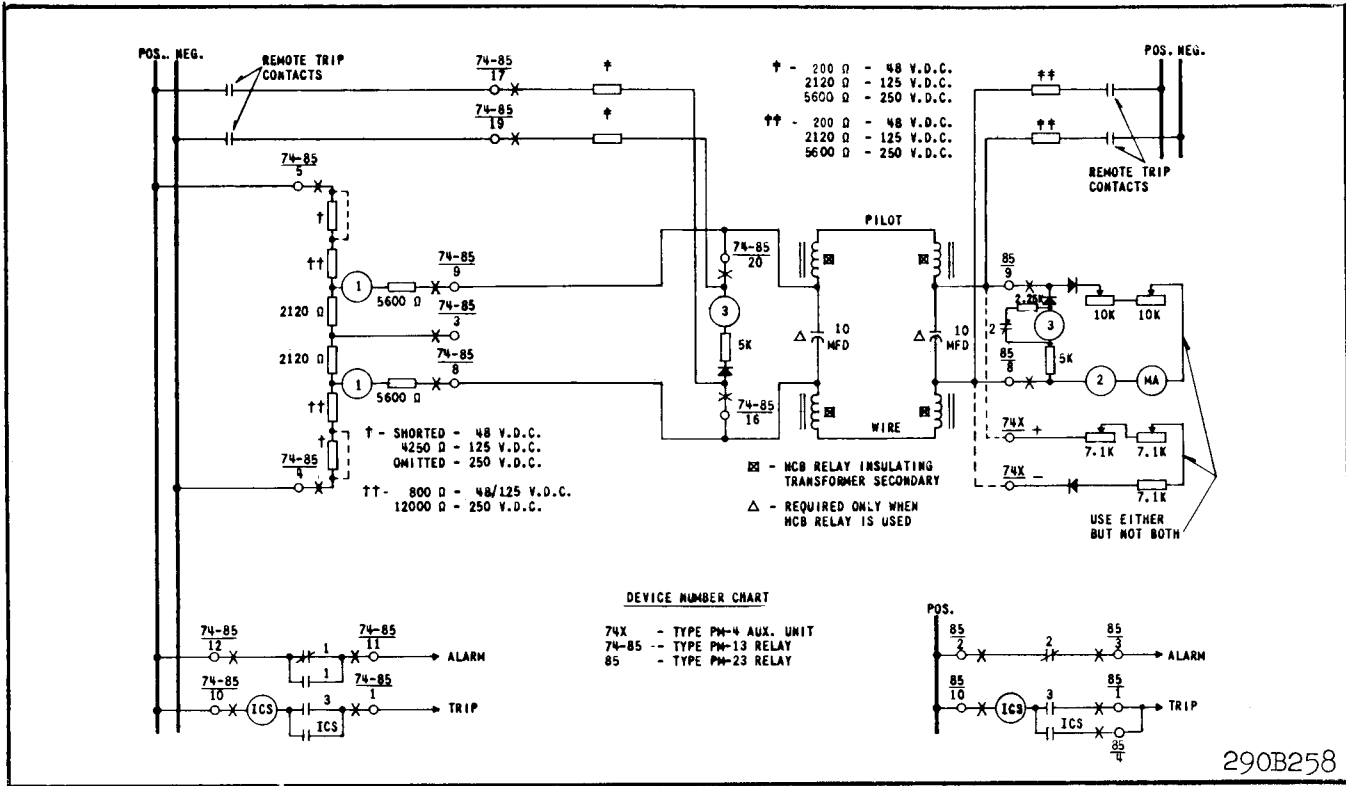

Fig. 27. External schematic of the DC type PM-13 relay with type PM-23 or PM-4 relay - Two terminal lines.

TYPE PM MONITORING RELAYS

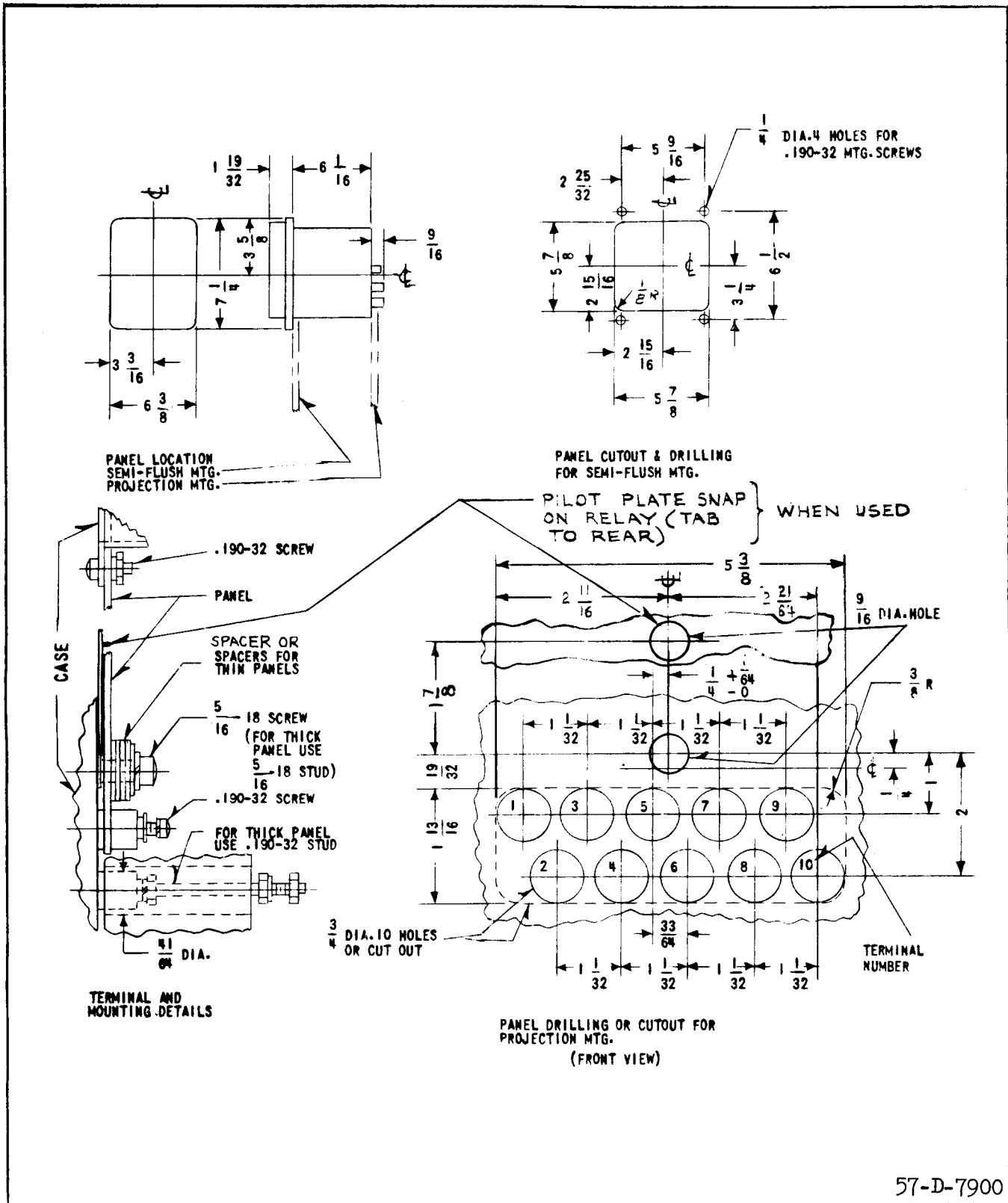

Fig. 32. Outline and Drilling Plan for the type PM-3, PM-5, & PMD-1 Relays in the type FT 11 case.

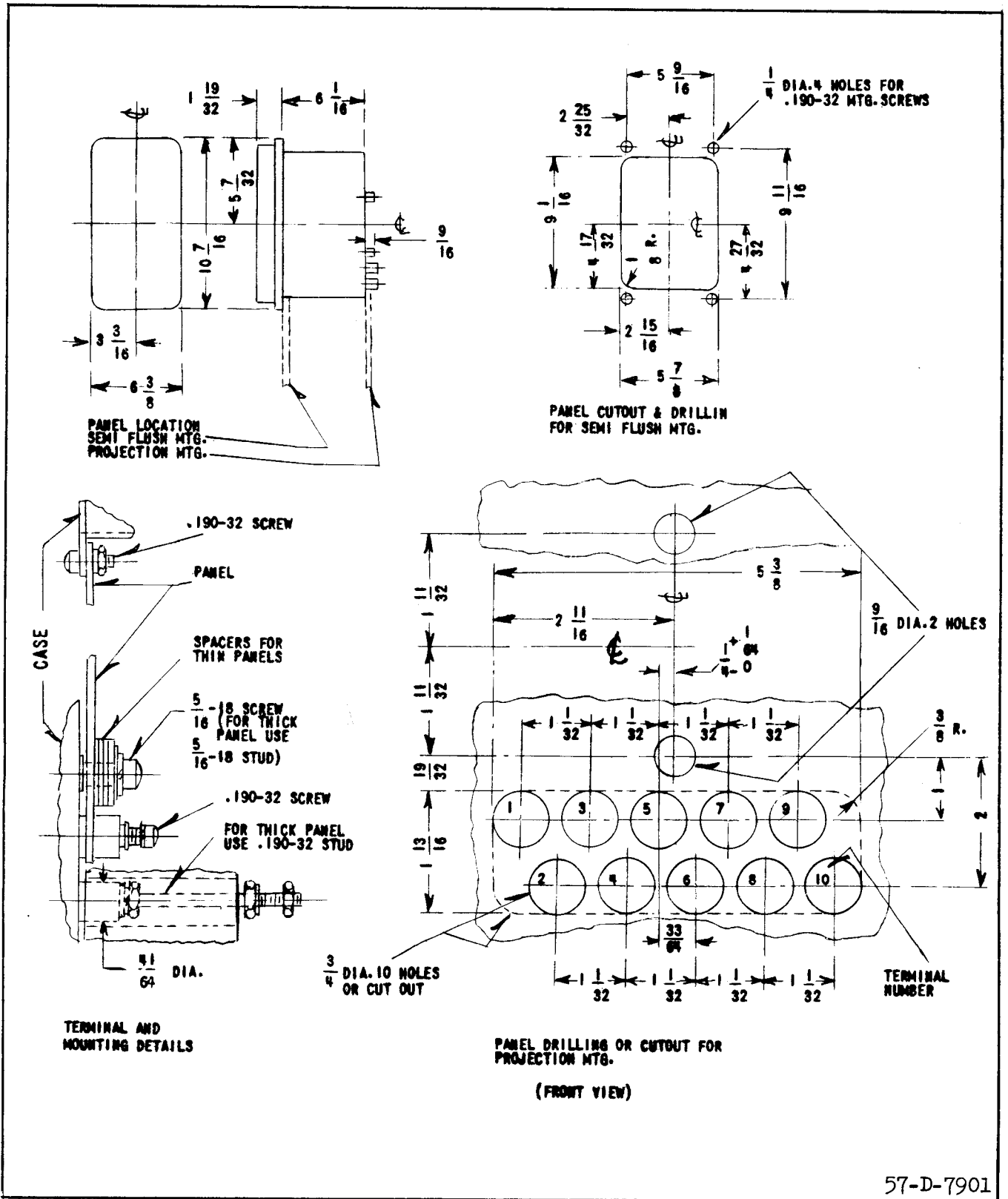

Fig. 33. Outline and Drilling Plan for the type PM-2, PM-23, PMA-1 and PMD relays in the type FT 21 case.

TYPE PM MONITORING RELAYS

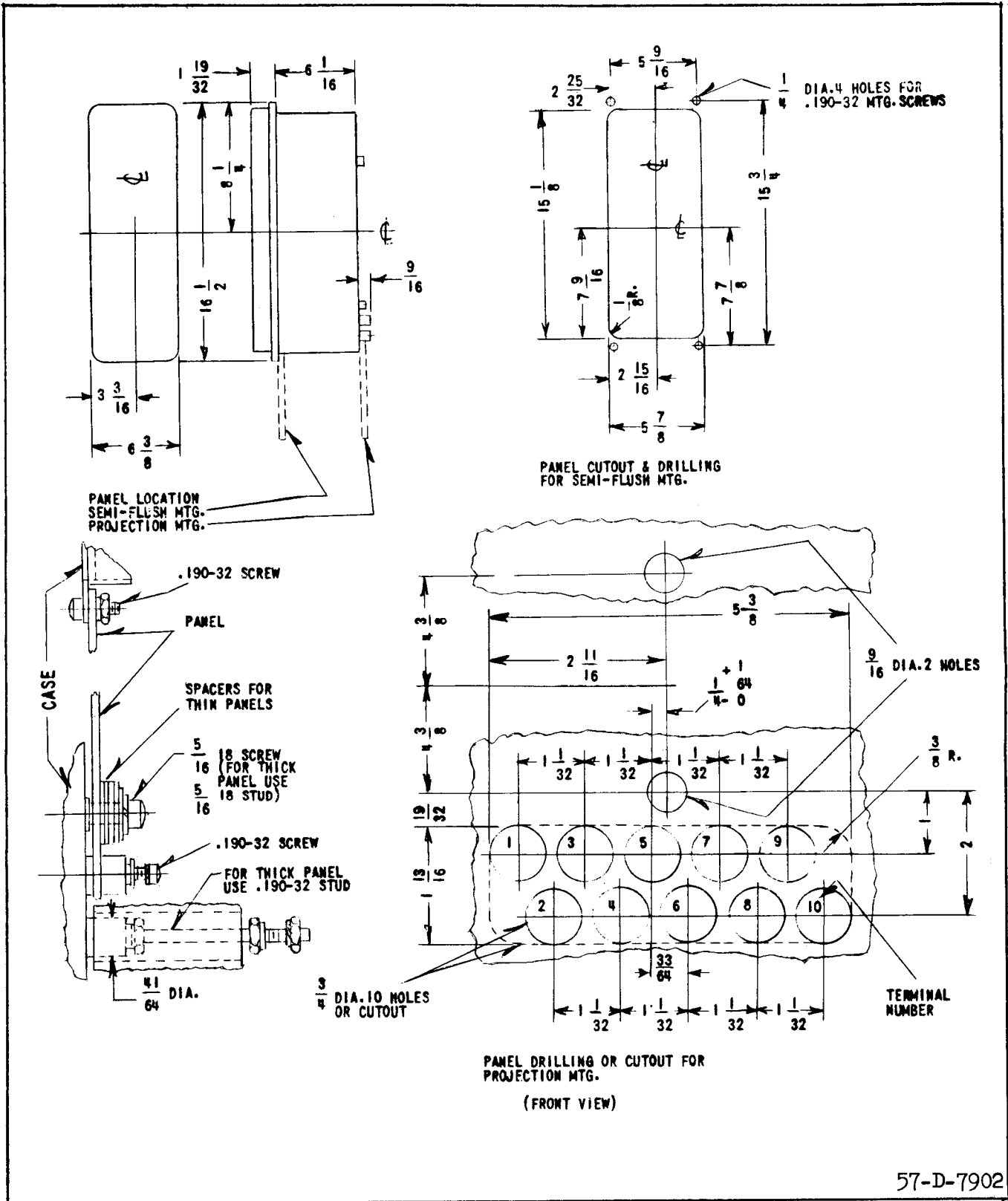

Fig. 34. Outline and Drilling Plan for the type PMA relay in the type FT 31 case.

57-D-7902

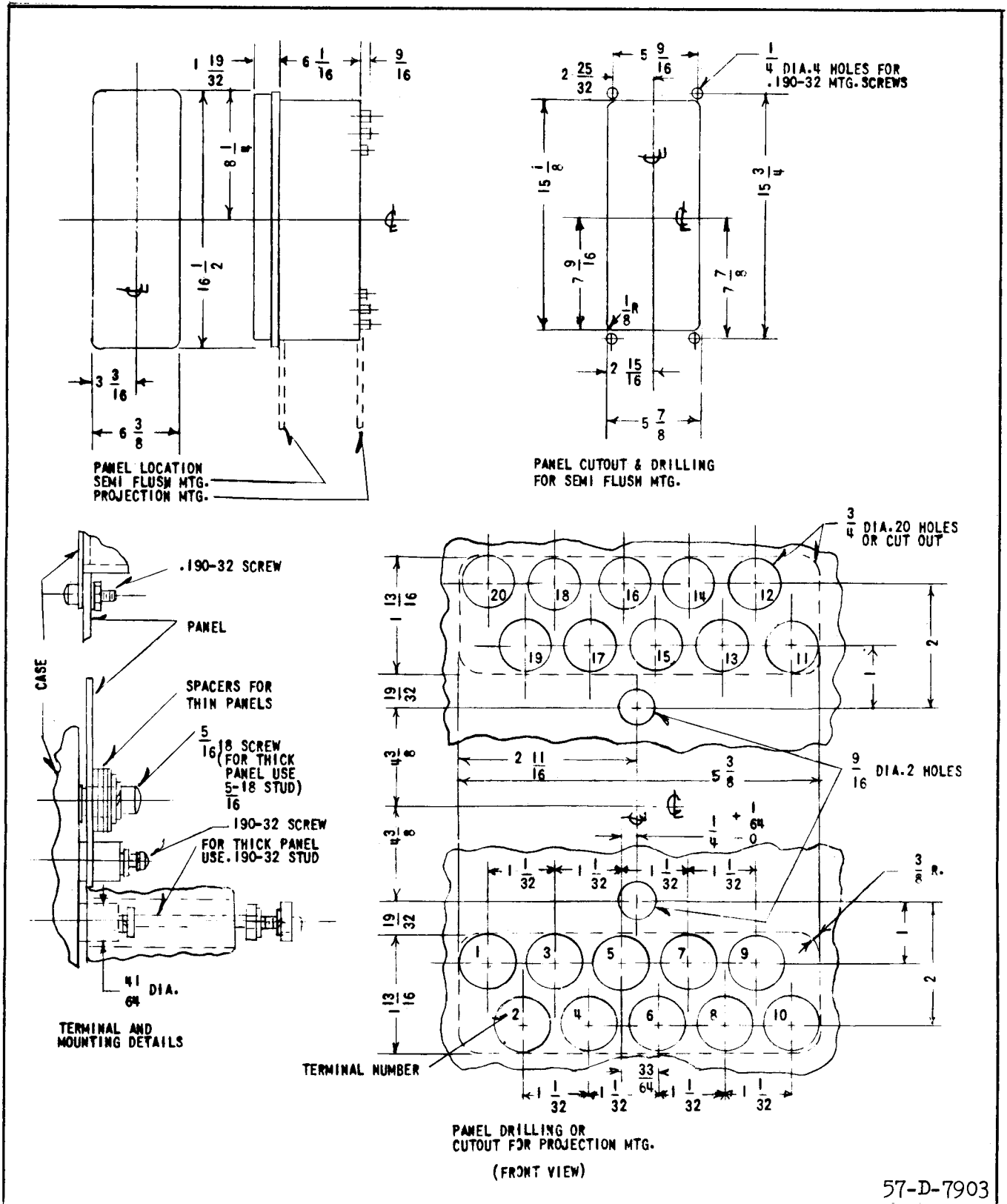
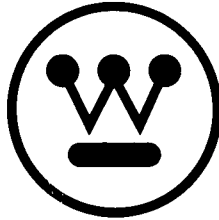

Fig. 35. Outline and Drilling Plan for the type PM-13 and PMG-13 relays in the type FT 32 case.



WESTINGHOUSE ELECTRIC CORPORATION
RELAY-INSTRUMENT DIVISION

NEWARK, N. J.

Printed in U.S.A.



INSTALLATION • OPERATION • MAINTENANCE INSTRUCTIONS

TYPE PM LINE OF RELAYS FOR PILOT-WIRE MONITORING AND TRANSFERRED TRIPPING

CAUTION Before putting protective relays into service, remove all blocking which may have been inserted for the purpose of securing parts during shipment, make sure that all moving parts operate freely, inspect the contacts to see that they are clean and close properly, and operate the relay to check the settings and electrical connections.

APPLICATION

Type PM Monitoring Relays provide continuous monitoring of a pilot-wire circuit to detect open circuits, short circuits, grounds, and wire reversal. In addition, transferred tripping can be effected where the PM-3, PM-13, PMG-13 or PM-23 relays are used. Table I illustrates the functions available with each relay. A 10 mfd. capacitor is supplied with each PM relay. This capacitor provides an a-c path between the two halves of the insulating transformer secondary windings as shown in Figs. 21 through 27.

Each circuit requires the following:

At one end to introduce monitoring current

One of the following:

For a-c Supply

For d-c Supply

PMA	PMD
PMA-1	PMD-1
PM-13 or PMG-13 (a.c.)	PM-13 or PMG-13 (d.c.)

At the other end to receive monitoring current (two-terminal line)

One PM-23 or PM-2 or PM-4

At the other ends to receive monitoring current (three-terminal line)

Two PM-23 or two PM-4 or two PM-2 or any combination of two of these relays.

CONSTRUCTION

PM relays consist of the following:

<u>PMA</u>	<u>PMA-1</u>
1-Polar Alarm Unit (1)	1-Polar Alarm Unit

1-Polar Ground Unit (5)	1-Tapped Transformer	1-Tapped Transformer
1-Tapped Transformer	1-Full-Wave Rectifier	1-Full-Wave Rectifier
1-Full-Wave Rectifier	3-4 mfd. Capacitors	1-4 mfd. Capacitor
3-4 mfd. Capacitors	1-Set of Voltage	1-Set of Voltage
1-Set of Voltage	Dividing Resistors	Dividing Resistors

PMD

PMD-1

1-Polar Alarm Unit (1)
1-Polar Ground Unit (5)
2-4 mfd. Capacitors
1-Set of Potential
Divider Resistors

1-Polar Alarm Unit
1-Set of Potential
Divider Resistors

PMG-13

PM-13

1-Polar Alarm Unit (1)
1-Polar Ground Unit (5)
1-Polar Trip Unit (3)
1-Indicating Contactor
Switch
1-Set of Potential
Divider Resistors
1-Tapped Transformer
(A.C. Relay only)
1-Full-Wave Rectifier
(A.C. Relay only)
1-Blocking Rectifier
2-Remote Trip Resistors
3-4 mfd. Capacitors
(A-C Relay)
2-4 mfd. Capacitors
(D-C Relay)

1-Polar Alarm Unit (1)
1-Polar Trip Unit (3)
1-Indicating Contactors
Switch
1-Set of Potential
Divider Resistors
1-Tapped Transformer
(A.C. Relay only)
1-Full-Wave Rectifier
(A.C. Relay only)
1-Blocking Rectifier
2-Remote Trip Resistor
1-4 mfd. Capacitor

PM-23

PM-2

1-Polar Alarm Unit (2)
1-Polar Trip Unit (3)
1-Indicating Contactor
Switch (ICS)
1-Milliammeter, 5.0 ma.
1-Set of Adjustable and
Fixed Resistors
2-Blocking Rectifiers

1-Polar Alarm Unit (2)
1-Milliammeter, 5.0 ma.
1-Set of Adjustable
Resistors
1-Blocking Rectifier

TYPE PM MONITORING RELAYS

PM-3

- 1-Polar Trip Unit (3)
- 1-Resistor
- 1-Blocking Rectifier
- 1-Indicating Contactor Switch (ICS)

PM-4

- 1-Blocking Rectifier
- 1-Set of Adjustable & Fixed Resistors

PM-5

- 1-Polar Ground Unit (5)
- 2-4 mfd. Capacitors
- 1-Fixed Resistor

TABLE I

FUNCTION	PMA & PMD	PMA-1 & PMD-1	PM-13	PMG-13	PM-23	PM-2	PM-3	PM-4	PM-5
Monitoring Current Source	X	X	X	X					
Receives Monitoring Current					X	X		X	
Trouble Alarm	X	X	X	X	X	X			X
Transmits Trip Signal	X †	X †	X	X	X †	X †	X †	X †	
Receives Trip Signal			X	X	X		X		
Sensitive Ground Detection	X			X					X
Measures Monitoring Current					X	X			

† With External Resistors

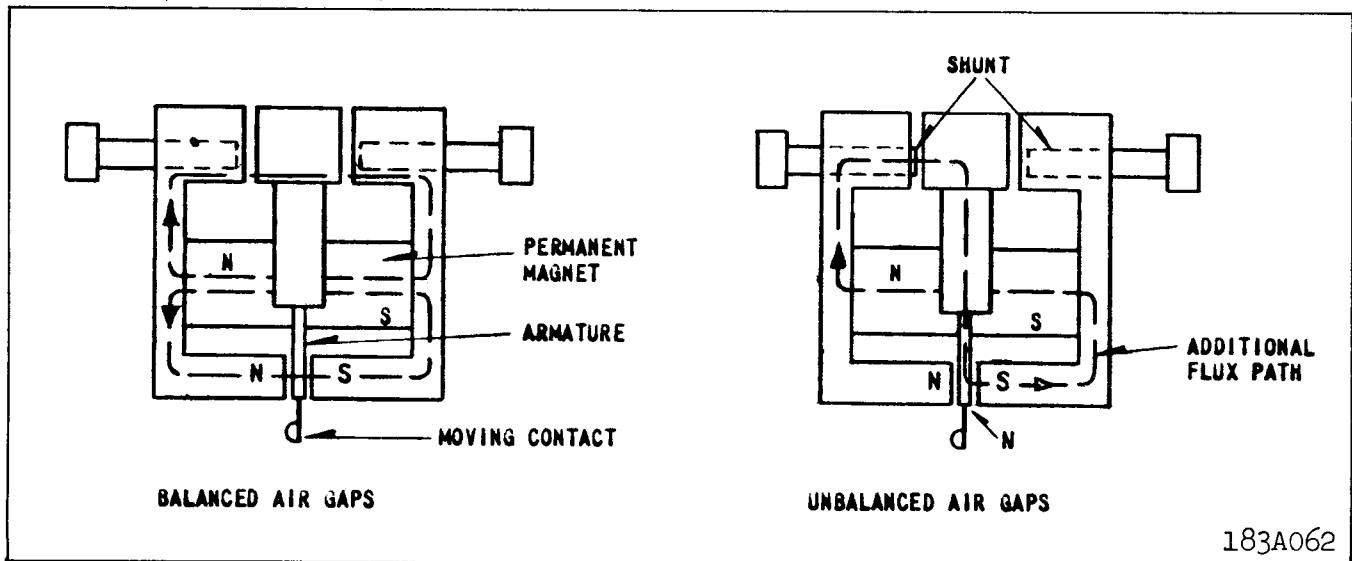

Fig. 1. Polar Unit Permanent Magnet Flux Paths.

183A062

Polar Unit

The polar unit consists of a rectangular shaped magnetic frame, an electromagnet, a permanent magnet, and an armature. The poles of the crescent shaped permanent magnet bridge the magnet frame. The magnetic frame consists of three pieces joined in the rear with two brass rods and silver solder. These non-magnetic joints represent air gaps, which are bridged by two adjustable magnetic shunts. The winding or windings are wound around a magnetic core. The armature is fastened to this core and is free to move in the front air gap. The moving contact is connected to the free end of a leaf spring, which, in turn, is fastened to the armature.

Indicating Contactor Switch

The d-c indicating contactor switch is a small clapper type device. A magnetic armature, to which leaf-spring mounted contacts are attached, is attracted to the magnetic core upon energization of the switch. When the switch closes, the moving contacts bridge two stationary contacts, completing the trip circuit. Also during this operation two fingers on the armature deflect a spring located on the front of the switch, which allows the operation indicator target to drop. The target is reset from the outside of the case by a push rod located at the bottom of the cover.

The front spring, in addition to holding the target, provides restraint for the armature and thus controls the pickup value of the switch.

OPERATION

Pilot Wire Monitoring

Monitoring current is introduced into the pilot wire as shown in the external schematics, figures 21 to 27, by the monitoring current source. External schematics showing other combinations are available on request. A nominal 20 volts is impressed across the 10 mfd. capacitor at the left-hand line terminal in Figures 21 to 27. This voltage produces a current circulating through one winding of the HCB insulating transformer, one pilot wire, the PM-23, PM-2, or PM-4, and back through the other pilot wire and the other winding of HCB insulating transformer.

Adjustment of the resistors of the PM-23, PM-2 or PM-4 relay at the other end of the pilot wire provides a normal one-milliampere d-c circulating current. In the case of three-terminal lines, the monitoring source relay output current is 2 ma. in order to pro-

vide each receiving end relay with 1 ma. The alarm unit of the monitoring current source relay is adjusted to float between the high and low current contacts with normal monitoring current. The PM-23, receiving-end alarm relay, is adjusted to float between the low-current alarm contact and a contact stop with 1 ma. flowing.

Short Circuits

A complete or partial short circuit on the pilot wires increases the current in the current-source relay, causing the high-current alarm contacts to close. The resulting current decrease in the PM-23 relay closes the alarm contact. Short circuits of 5000 ohms or less will be detected.

Open Circuits

Current decreases to zero in all relays. Low-current alarm contact of the current source relay closes. Alarm contact of PM-23 relay closes.

Reversed Wires

On applications using the PM-23 relay, current increases in the sending end relay to close the high-current alarm contacts. Current drops to zero in the PM-23 relay monitoring coil to close the low-current alarm contacts.

If the pilot wire should be opened and reclosed with reversed connections when the PM-23 relay is in service, the alarm contact (2) in the PM-23 drops out. The alarm contact dropping out shunts the trip unit coil (3), and prevents the trip unit contact (3) from operating momentarily. The trip unit contact is prevented from operating because the capacitor at the sending end discharges through the pilot wire and the trip unit (3) circuit. This will have no effect on remote trip operation.

The current decreases in both sending and receiving end relays when the PM-2, or PM-4 relays are used. Low current alarm contacts close.

The voltage-divider circuit of the PMA, PMD, and PMG-13 source relays has its midpoint grounded through a current-limiting resistor. Thus, a pilot-wire ground will cause an increase in current in one coil circuit, and a decrease in the other one. This unbalance in the current flowing through the two windings (5) of the ground alarm relay unit will cause it to close one of its contacts (depending on which pilot wire is grounded) to give an alarm. Grounds of 10,000 ohms or less will be detected.

TYPE PM MONITORING RELAYS

For adding the sensitive ground detection where PMA-1, PMD-1, or PM-13 relays have been installed, the PM-5 relay can be added to the circuitry, as shown in figure 24. This relay also has a 10,000-ohm ground sensitivity.

Transferred Tripping

Breakers located at the PMG-13 or PM-13 and PM-3 or PM-23 stations can be tripped by the application of a d-c voltage to the pilot wires at remote locations, as shown in figures 21 to 27. Transferred tripping can be effected from any location by applying 48 volts d-c (through dropping resistors when required) to the pilot wire with polarity opposite to that of the monitoring voltage. When tripping the PM-23, the current is increased above 2.0 ma, in reverse direction, to close the trip contact. When tripping the PMG-13 or PM-13, the reversed d.c. voltage operates the trip unit (3).

See Tables II and III for tripping resistor values. Nominal tripping currents is 5ma. at all rated voltages.

Polar Unit

Polar unit flux paths are shown in figure 1. With balanced air gaps, permanent magnet flux flows in two paths, one through the front, and one through the rear gaps. This flux produces north and south poles, as shown. By turning the left shunt in, some of the flux is forced through the armature, making it a north pole. Thus, reducing the left hand rear gap will produce a force tending to pull the armature to the right. Similarly, reducing the right hand gap will make the armature a south pole and produce a force tending to pull the armature to the left.

The alarm unit contacts of the sending and receiving end relays are biased to move to the left when the relay is deenergized. The PMG-13 or PM-13 and PM-23 trip unit contact is biased to move to the left when the relay is deenergized. The PM-5 is adjusted so that the moving contact floats when the relay is deenergized.

CHARACTERISTICS

Nominal Calibration Values

Nominal current values to close contacts are listed in Tables IV and V.

Voltage Ratings

Supply voltage ratings of the monitoring source

relays to obtain continuous monitoring current are as follows:

DC - 48, 125, and 250 volts

AC - 120 volts, 60 cycles (Primary taps 100, 110, 120 & 130)

Voltage impressed on the pilot wire is a nominal 20 volts for monitoring, and 48 volts for tripping.

Supply voltage ratings to obtain remote tripping are: 48, 125, and 250 volts d-c.

Coil Resistance (each winding)

Alarm coil (1)	
two terminal line	1050-1250 ohms
three terminal line	700-900 ohms
Alarm coil (2)	2200-2600 ohms
Trip coil (3)	1800-2200 ohms
Ground Alarm coil (5)	5200-5800 ohms

PM-4 and PM-23 Resistance

Nominal PM-4 and PM-23 total resistance when adjusted for service is 20,000 ohms less pilot wire loop resistance at 1 ma.

PMA, PMA-1 and AC PMG-13, PM-13 Burden

0.5 VA at tap voltage	-	2-terminal line relay
1.0 VA at tap voltage	-	3-terminal line relay

Rectifiers

Approximate forward resistance - 560 ohms at 1 ma
300 ohms at 2 ma

Rating

Continuous forward	
current - amperes	- 1
Continuous back	
voltage - rms volts	- 200

Remote Tripping

Remote trip resistors are listed in Table II and III for 48, 125, and 250 volts d-c.

The relays have sufficient thermal capacity to withstand 20 MA d-c continuously when remote tripping. Nominal trip currents in the tripping relays are 5.0 MA d-c with 48, 125, and 250 volts d-c supply and a 2000-ohm pilot wire.

TABLE II

PMA, PMA-1, PMD, AND PMD-1 APPLICATIONS
EXTERNAL RESISTORS FOR D.C. REMOTE TRIPPING
(2 REQUIRED PER STATION)

# LINE TERMINALS	D.C. VOLTAGE	STATION A PMA or PMA-1	STATION A PMD or PMD-1	STATION B PM-2 & PM-3 or PM-23 or PM-4	STATION C PM-2 & PM-3 or PM-23 or PM-4	TO OPERATE
2	48	200	200	—	—	PM-23 or PM-3
	125	3550	3550	—	—	"
	250	9300	9300	—	—	"
3	48	200	200	—	—	"
	125	2000	2000	—	—	"
	250	5600	5600	—	—	"

TABLE IIIA

PMG-13 AND PM-13 (D.C. SUPPLY) APPLICATIONS
RESISTORS FOR D.C. REMOTE TRIPPING
(2 REQUIRED PER STATION)

# LINE TERMINALS	D.C. VOLTAGE	STATION A PMG-13 or PM-13	STATION B PM-2 & PM-3 or PM-23 or PM-4	STATION C PM-2 & PM-3 or PM-23 or PM-4	TO OPERATE
2	48	200 †	200	—	PMG-13 or PM-13 and PM-23 or PM-3
	125	2120 †	2120	—	"
	250	5600 †	5600	—	"
3	48	200 †	200	200	"
	125	1500 †	1500	1500	"
	250	4000 †	4000	4000	"

† Mounted in Relay

TABLE IIIB

PMG-13 AND PM-13 (A.C. SUPPLY) APPLICATIONS
(2 REQUIRED PER STATION)
RESISTORS FOR D.C. REMOTE TRIPPING

# LINE TERMINALS	D.C. VOLTAGE	STATION A PMG-13 or PM-13	STATION B PM-2 & PM-3 or PM-23 or PM-4	STATION C PM-2 & PM-3 or PM-23 or PM-4	TO OPERATE
2	48	200 †	200	—	PMG-13 or PM-13 and PM-23 or PM-3
	125	2120 †	2120	—	"
	250	5600 †	5600	—	"
3	48	200 †	200	200	"
	125	1500 †	1500	1500	"
	250	4000 †	4000	4000	"

† Mounted in Relay

TABLE IV

NOMINAL CALIBRATION VALUES - TWO TERMINAL LINES

<u>RELAY</u>	<u>LOW CURRENT ALARM</u> ¹	<u>HIGH CURRENT ALARM</u> ²	<u>TRIP</u>
PMA or PMA-1	0.7 ma	1.3 ma	—
PMD or PMD-1	0.7	1.3	—
PM-5 †	—	±0.3	—
PMG-13 or PM-13	0.7 ††	1.3 ††	14 V.
PM-23 or PM-2 & PM-3 †	0.7	—	14 V.

† Same relay as for three-terminal lines

†† These are pilot-wire current values

1—Left-hand contacts, front view.

2—Right-hand contacts, front view.

TABLE V

NOMINAL CALIBRATION VALUES - THREE TERMINAL LINES

<u>RELAY</u>	<u>LOW CURRENT ALARM</u>	<u>HIGH CURRENT ALARM</u>	<u>TRIP</u>
PMA or PMA-1 •	1.7 ma	2.3 ma	—
PMD or PMD-1	1.7	2.3	—
PM-5 †	—	±0.3	—
PMG-13 or PM-13	1.7 ††	2.3 ††	14 V.
PM-23 or PM-2 & PM-3 †	0.7	—	14 V.

† Same relay as for two-terminal lines

†† These are pilot-wire current values

Trip Circuit

The main contacts will safely close 30 amperes at 250 volts d-c and the seal-in contacts of the indicating contactor switch will safely carry this current long enough to trip a circuit breaker.

The indicating contactor switch has two taps that provide a pickup setting of 0.2 or 2 amperes. To change taps requires connecting the lead located in front of the tap block to the desired setting by means of a screw connection.

Trip Circuit Constant

Indicating Contactor Switch (ICS)

0.2 ampere tap 6.5 ohms d-c resistance

2.0 ampere tap 0.15 ohms d-c resistance

SETTING THE RELAY

Operating units of all relays are adjusted in the factory to the values listed in Tables IV and V to a tolerance of ±5%. No settings are required on these units.

For all 48/125-volt d.c. relays, connect jumpers across resistors as shown on the internal schematics.

PM-4, PM-2, and PM-23 Relays

Adjust the resistors in the PM-4, PM-2, or PM-23 relay or relays to a value of 1 MA d-c with the monitoring circuits connected for service. Use the milliammeter in the PM-23 for this purpose or use a portable milliammeter with a resistance of less than 200 ohms. Where it is not practical on three-terminal lines to adjust both receiving relays simultaneously, set one receiving relay for 18,000 ohms total resistance (including relay coil and resistors) by measurement prior to final adjustment of the other receiving relay. This procedure will minimize the change in monitoring current in the first relay to be adjusted when making the final adjustment of the second relay.

PMA, PMA-1, PMG-13 and PM-13 Relays

Select the transformer tap nearest to expected normal a-c supply voltage. The full wave rectifier is

connected to a secondary transformer tap. Where desired, the output voltage can be raised about 5% by reconnecting across the full secondary winding.

Indicating Contactor Switch

No setting is required on the ICS unit except the selection of the 0.2 or 2.0 ampere tap setting. This selection is made by connecting the lead located in front of the tap block to the desired setting by means of the connecting screw. When the relay energizes a type WL relay switch, or equivalent, use the 0.2 ampere tap.

INSTALLATION

The relays should be mounted on switchboard panels or their equivalent in a location free from dirt, moisture, excessive vibration, and heat. Mount the relay vertically by means of the four mounting holes on the flange for semi-flush mounting or by means of the rear mounting stud or studs for projection mounting. Either a mounting stud or the mounting screws may be utilized for grounding the relay. The electrical connections may be made directly to the terminals by means of screws for steel panel mounting or to the terminal studs furnished with the relay for thick panel mounting. The terminal studs may be easily removed or inserted by locking two nuts on the stud and then turning the proper nut with a wrench.

For detailed FT case information, refer to I.L. 41-076.

Where the potential to ground impressed on the relays can exceed 700 volts, a drainage reactor in conjunction with a KX-642 tube, or the reactor in conjunction with 700 volt carbon-block arresters, is recommended. For details, see Protection of Pilot-Wire Circuits, AIEE Committee Report, paper 58-1190, AIEE Transactions, 1959, Volume 78, Part III B pp. 205-212. Also, see AIEE Special Publication S-117, Applications and Protection of Pilot-Wire Circuits for Protective Relaying, July 1960.

ADJUSTMENTS AND MAINTENANCE

The proper adjustments to insure correct operation of this relay have been made at the factory and should not be disturbed after receipt by the customer. If the adjustments have been changed, the relay taken apart for repairs, or if it is desired to check the adjustments at regular maintenance periods, the instructions in the succeeding sections should be followed.

Acceptance Tests

The following tests are recommended when the relay is received from the factory. If the relay does not perform as specified below, the relay either is not properly calibrated or it contains a defect.

Indicating Contactor Switch (ICS)

Close the contact of the tripping unit and pass sufficient direct current through the trip circuit to close the contacts of the ICS unit. This value of current should not be greater than the particular ICS tap setting being used (0.2 or 2.0). The indicator target should drop freely.

PMA and PMA-1 Relays

Alarm Unit (1)

Set the primary tap on 120 volts. Connect a variable resistor of approximately 20,000 ohms in series with a low-range d-c milliammeter across terminals 6 and 7 with the instrument positive connected to terminal 7. Apply 120 volts at rated frequency to terminals 4 and 5. Adjust the 20,000-ohm resistor to obtain a current of one ma. d.c. For a three-terminal line relay, use a 10,000-ohm resistor and set the current to 2 ma. d.c. At this value, the moving contact of the alarm or monitoring relay unit (1) should float between the two sets of stationary contacts. In the PMA relay, the ground alarm unit (5) contact should also float. (This contact will also float when the relay is de-energized.) Increase and decrease the one or two-milliampere monitoring current to check the calibration values listed in Tables IV and V.

Ground Unit (5)

Reconnect the 20,000-ohm resistor. For the PMA relay only, short terminals 7 and 3. The contact of the ground alarm unit (5) should close to the right when the relay is energized. Remove the short, and connect it between terminals 6 and 3. The ground alarm unit (5) should close to the left. The action of the monitoring unit (1) contact is of no significance in this simulated pilot-wire ground test. To check the pickup current of the ground detector, first remove the 20,000-ohm resistor from terminals 6 and 7. Connect a 0-1 d.c. milliammeter in series with a variable resistor of about 50,000 ohms between terminals 3 and 6. The ground unit should close its left-hand contact at approximately 0.3 ma. d.c. With the milliammeter and resistor connected between terminals 3 and 7, the right-hand contact should close at 0.3 ma. d.c.

TYPE PM MONITORING RELAYS

PMD and PMD-1 Relays

Alarm and Ground Units

Connect an adjustable 20,000-ohm resistor (or 10,000-ohms for a 3-terminal relay) in series with a d-c milliammeter across terminals 6 and 7 with the instrument positive connected to terminal 7. Apply rated d-c voltage to terminals 8 and 9 with positive on terminal 9. Now check the PMD and PMD-1 relays, following the procedure given in the previous section for the PMA and PMA-1 relays, respectively. Note, however, that terminal 5 of the PMD relay corresponds to terminal 3 of the PMA relay.

PM-2, PM-3, and PM-23 Relays

Alarm Unit (2)

Apply a variable d-c voltage of approximately 20 volts to relay terminals 8 and 9 (terminal 9 positive) of the PM-2 or PM-23 relay. Adjust the voltage to obtain a reading of one ma. on the relay milliammeter. The monitoring polar unit (2) contacts should float. Reduce the current gradually. The monitoring alarm contacts should close at 0.7 ma. d.c. The tripping unit (3) of the PM-23 relay should not move during this test. The milliammeter has been adjusted to read 1 ma. $\pm 5\%$. As a result the pointer may not read zero for a zero current condition.

Tripping Unit (3)

To check the PM-3 relay or the tripping unit of the PM-23 relay, apply the variable d-c voltage in series with an external milliammeter to relay terminals 8 and 9 with terminal 8 positive for the PM-23 relay, or terminal 9 positive for the PM-3 relay.

- * When checking the pickup of the PM-23 trip unit block open the alarm unit contacts (2) so as to remove the shunt resistor from around the trip coil (3).

The tripping relay unit (3) should pick up with positive action at 14 volts d.c. and should drop out at approximately 10 volts. The alarm unit of the PM-23 relay will not operate during this test.

PM-4 Relay

This device is simply a set of resistors and a diode to connect into the pilot-wire circuit to provide a path for the monitoring current. The resistors can be checked with an ohmmeter, and the diode can be checked either with an ohmmeter, or as explained in the section entitled "Rectifier Check" under "Routine Maintenance". If an ohmmeter is used, the difference in forward and reverse resistance readings obtained will be dependent on the current flowing through the diode.

PM-5 Relay

Apply 5 volts d.c. in series with a 0-1 d.c. milliammeter and a 20,000-ohm variable resistor to terminals 6 and 7 with positive on terminal 6. The left-hand contact should close at approximately 0.3 ma. Now apply the same circuit to terminals 8 and 9 with positive on terminal 9. The right-hand contact should close at approximately 0.3 ma.

PM 13 Relays - A.C. and D.C.

Alarm Unit (1)

Connect a variable 20,000-ohm resistor (10,000 ohms for a 3-terminal-line relay) in series with a d-c milliammeter across terminals 8 and 9 with the instrument positive on terminal 9. For the a-c relay, set the primary tap on 120 volts. Now apply the rated supply voltage to terminals 4 and 5. This will be 48, 125, or 250 volts d.c., or 120 volts a.c. as indicated on the relay nameplate. Adjust the variable resistor to obtain a current of one ma. for a 2-terminal line relay, or 2 ma. for a 3-terminal relay. At this value, the moving contacts of the alarm or monitoring (1) relay unit (the upper polar unit) should float between the two sets of stationary contacts. Increase and decrease the one or 2 ma. monitoring current to check the calibration values listed in Tables IV and V.

Tripping Unit (3)

To check the operation of the tripping unit 3 (the lower polar unit), apply a d.c. potential across terminals 16 (positive) and 20 (negative). The tripping polar unit should pick up at 14 volts, and should drop out at approximately 10 volts. The resistance of the series dropping resistors for transferred tripping (listed in Tables III A and III B) can be checked with an ohmmeter. The circuit location of these resistors can readily be seen from the external schematic, Figure 27.

PMG-13 Relays - A.C. and D.C.

Alarm and Tripping Units

Follow the procedure given in the previous section for the a-c. and d-c. PM-13 relays.

Ground Unit (5)

Connect the 20,000-ohm (or 10,000-ohm) resistor and milliammeter across terminals 8 and 9. With rated voltage applied and one ma. (or 2 ma.) flowing, successively short circuit terminals 3 and 8, then 3 and 9. The ground alarm unit 5 (lower polar unit) should move first to the left, then to the right. To check the pickup current of the ground detector, first remove the 20,000-ohm resistor from terminals 8 and 9. Connect a 0-1 d.c. milliammeter in series

with a variable resistor of about 50,000 ohms between terminals 3 and 8. The left-hand contact should close at approximately 0.3 ma. d.c. With the milliammeter resistor connected, between terminals * 3 and 9, the right-hand contact should close at 0.3 ma. d.c. The external schematic diagrams for these relays are shown in Figure 23 and 25.

Routine Maintenance

CAUTION - Do not make any performance check, calibration tests, or adjustments while the PM relays are energized or connected to the pilot wires, to prevent the possibility of inadvertently causing a break operation. The PM relays may be removed from service for testing, without jeopardizing HCB relay protection, providing that the connections between the 10-mfd capacitor and the HCB insulating transformer are not disturbed.

Contacts

All contacts should be periodically cleaned. A contact burnisher S#182A836H01 is recommended for this purpose. The use of abrasive material for cleaning contacts is not recommended because of the danger of embedding small particles in the face of the soft silver and thus impairing the contact.

Operational Check

In addition to cleaning contacts, it is recommended that an operational check be performed periodically by opening and short-circuiting the pilot wires, as well as grounding them at the relay terminals. **Note:** These pilot-wire faults should not be applied directly to the pilot wires when the HCB relays are in service. It is also recommended that the trip circuits of the PM relays be opened (where tripping is used), to prevent the possibility of inadvertently tripping the associated circuit breaker during testing. If the relays do not perform as expected, and diode failure is suspected, the diode tests described in the following section may be performed.

Rectifier (Diode) Check

If there is suspicion of a rectifier (diode) failure, apply 30 volts d.c. reverse voltage (positive on arrow-head) through a 300-ohm resistance to the diode. Measure the voltage across the diode. If this voltage is not essentially 30 volts, the diode is short-circuited. Now apply 30 volts d.c. in the forward direction through the 300-ohm resistor, and measure the voltage across the resistor. If the voltage is not essentially 30 volts, the diode may have a high forward resistance. If the voltage is zero, the diode is open-circuited.

Calibration

If the relay has been dismantled or the calibration has been disturbed, use the following procedure for calibration.

With the permanent magnet removed, see that the moving armature floats in the central area of the air-gap between the poles of the polar unit frame. If necessary, loosen the core screw in the center rear of the unit and shift the core and contact assembly until the armature floats. (This can best be done with the polar unit removed from the relay.) Then retighten the core screw and replace the permanent magnet with the dimple (north pole) on the magnet to the left when viewed from the front.

Polar Units-General

The following mechanical adjustments are given as a guide, and some deviation from them may be necessary to obtain proper electrical calibration.

Magnetic Shunt Adjustment

The sensitivity of the polar unit is adjusted by means of two magnetic, screw-type shunts at the rear of the unit, as shown in Fig. 1. These shunt screws are held in proper adjustment by a flat strip spring across the back of the polar unit frame, so no locking screws are required. Looking at the relay, front view turning out the right-hand shunt to open the right-hand air gap decreases the amount of current required to close the right-hand contact. Conversely, drawing out the left-hand shunt increases the amount of current required to close the right-hand contact, or decreases the amount of current required to close the left-hand contact (with the proper direction of current flow). Also, if a relay trips to the right at the proper current, the dropout current can be raised by turning in the right-hand shunt. The two shunt-screw adjustments are not independent, however, and a certain amount of trimming adjustment of both shunt screws is generally necessary to obtain the desired pickup and dropout calibration.

In general, the farther out the two shunt screws are turned, the greater the toggle action will be, and as a result, the lower the dropout current. For the tripping units (3) of the PM-3, PM-13, and PM-23 relays, toggle action is desirable, with a dropout current around 75 percent of the pickup current. For the monitoring alarm relay units, toggle action is not desired. Instead, the armature is adjusted to float between the pole faces at a given current (1 or 2

TYPE PM MONITORING RELAYS

The following chart indicates the units present in each relay.

FUNCTION AND UNIT	PMA PMD	PMA-1 PMD-1	PM2	PM3	PM4	PM5	PM13	PMG13	PM23
Alarm for p.w. open, short or reversal (1) (2)	X	X	X				X	X	X
Transfer - Trip Unit (3)				X			X	X	X
Alarm for p.w. ground (5)	X					X		X	
D.C. Path for Monitoring Current					X				

ma.), and to move gradually toward the high or low-current alarm as the coil current is increased or decreased. Similarly, the floating adjustment of the armature of the ground alarm unit (5) requires that both shunt screws be turned in relatively far. Then the armature will move gradually to the left or right as the current through the two #5 coils is unbalanced.

The electrical calibration of the polar unit is also affected by the contact adjustment as this changes the position of the polar unit armature. Do not change the contact adjustment without rechecking the electrical calibration.

Contact Adjustment - All Relays

For all monitoring alarm units, designated (1) or (2), turn in all the stationary contact and contact stop screws until they just touch the moving contact. Advance the screws to hold the armature in the central portion of the magnetic air gap between the two pole faces. (The stationary contact screws have a round silver contact face; the stop screws do not have this silver facing.) Now back off all the contact and contact stop screws one full turn. This will give a total contact travel of 0.050 inch. When the relay is properly calibrated, some touch-up adjustment may be necessary so that double contacts will both close at the same current value. The contact gap between the floating moving contact and the right-hand or left-hand stationary contacts or contact stops will be approximately 0.025 inch when the relay is in operation.

For the tripping (3) units of the PM-3, PM-13, PMG-13, and PM-23 relays, adjust the contacts as described in the previous paragraph, except back off the contact and stop screws one-half turn each to

give a total moving contact travel of approximately 0.025 inch. In operation of the tripping unit, the moving contact will normally rest against the contact stop screws, and will pick up only for a transferred-tripping operation.

For the pilot-wire ground alarm unit (5) of the PMA, PMD, PM5, and PMG-13 relays, follow the same general procedure except back off both stationary contact screws two turns each. This will give a contact gap of 0.050 on each side of the moving contact when it is its normal central position.

Electrical Calibration - All Relays

In the following sections, the calibration instructions are given for the polar unit which performs a certain function, such as alarm (1) or (2), ground (5), or trip (3), rather than giving calibration instructions for each complete relay. In this way, considerable duplication of instructions has been eliminated.

Alarm Unit (1)

Connect the relay as described under Acceptance Tests for the particular relay involved. Screw the two magnetic shunts all the way in, then back them out five turns each. With the relay energized at rated voltage, set the monitoring current at 1.3 or 2.3 ma. d.c. for 2 or 3-terminal relay respectively, by adjusting the external resistor. If the relay does not close its right-hand contact, turn in the left shunt screw until the right-hand contact just closes. If the right-hand contact is closed at 1.3 ma., turn in the right shunt until a point is reached when the right-hand contact is just closed at 1.3 ma.

Now drop the current to 0.7 ma. and adjust the opposite shunt until the left-hand contact just closes

at 0.7 ma. d.c. At 1.0 ma. d.c., the moving contact should float half way between the two sets of stationary contacts with a 0.025-inch gap on each side. Recheck the high and low current calibration several times, touching up the shunt adjustments as required to obtain the desired calibration.

Polarization Check

For all the source relays, which are listed below, make the following additional calibration check:

- PMA PM-13 (a.c. and d.c.)
- PMA-1 PMG-13 (a.c. and d.c.)
- PMD
- PMD-1

After calibration as described in the previous sections, connect a 20,000 ohm resistor (or 10,000 ohms for 3-terminal applications) across the output terminals, and energize the relay at its rated supply voltage. With these connections, approximately one (or two) milliamperes d.c. will flow through the monitor relay coils and external resistor, thus representing normal operating conditions.

Now momentarily (one second or so) apply 48 volts d.c. directly to the pilot-wire terminals of the relay, as indicated in the following table.

<u>Relay</u>	<u>Terminals for Momentary Application of 48 V. d.c.</u>	
	<u>POS.</u>	<u>NEG.</u>
PMA, PMA-1 } PMD, PMD-1 }	6	7
PM-13 (a.c. or d.c.) } PMG-13 (a.c. or d.c.) }	8	9

After momentary application of the transfer-trip voltage as just explained, recheck the calibration of the monitoring alarm unit (1). If it has changed, make necessary trimming adjustments of the shunt screws until there is no change in calibrating of the alarm unit (1) after the transfer-trip voltage has been applied. The purpose of this test is to compensate for the small residual magnetism in the relay unit. The ground alarm unit (5) will not be affected by this test as the ampere-turns of the two windings cancel each other.

Alarm Unit (2)

For the alarm unit of the PM-2 or PM-23 relays, adjust the shunts so that the relay moving contact

floats at one ma. d.c., and closes the left-hand contact at 0.7 ma. d.c. The moving contact should float midway between the contact and contact stop at 1.0 ma. d.c. There is no high-current calibration for this relay unit.

Now apply 48 volts d.c. momentarily (one second or so) across the alarm unit coil-circuit terminals in a direction to operate the alarm relay. Then recheck the alarm unit calibration. If there is any change, touch up the shunt adjustments until there is no change in calibration after 48 v. d.c. has been applied.

Tripping Unit (3)

To calibrate the tripping unit of the PM-3, PM-13, PMG-13, or PM-23 relays apply a d.c. voltage as explained below, to the following relay terminals:

Relays	D.C.	Voltage
	Pos.	Neg.
PM-3	9	8
PM-13 (a.c. or d.c.)	16	20
PMG-13 (a.c. or d.c.)	8	9
PM-23	8	9

Momentarily (one second or so) apply 48 volts d.c. to the terminals shown in the chart. Then starting with both shunts all the way in, turn out the right-hand shunt screw until the relay closes its right-hand trip contact at 14 volts d.c. (This will give approximately 2 ma. through the relay coil.) Now draw out the left-hand shunt until the relay resets with toggle action (not gradually) at not less than 10 volts d.c. When the calibration is approximately correct, again apply 48 volts d.c. to the indicated terminals, then recheck the pickup and dropout voltage, making any necessary trimming adjustments of the shunts. When the relay is properly adjusted, the application of 48 volts.d.c. will not change the pickup or dropout voltage points. The relay should trip and reset with toggle action in this application. This will require both shunt screws to be withdrawn farther than for floating action.

Ground Alarm Unit (5)

For the PM-5 relay, turn both shunt screws all the way in, then back them out five turns each. Pass a current of 0.3 ma. d.c. in terminal 6 and out terminal 7. Following the same general procedure as described previously in the section entitled "Alarm Unit (1)," adjust the shunt screws so that the left-hand contact closes at 0.3 ma. Now pass 0.3 ma. d.c.

TYPE PM MONITORING RELAYS

in terminal 9 and out terminal 8, and adjust for closing of the right-hand contact at 0.3 ma. Recheck both pickup points several times, and make trimming adjustments of both shunts as required to obtain contact closing at 0.3 ma. d.c. in each direction.

For the ground unit (5) of the PMA, PMD, and PMG-13 relays, connect a variable resistance of about 50,000 ohms in series with a 0-1 d.c. milliammeter between the terminals indicated in the following table:

Turn the shunts all the way in, then back them out five turns each. With the relay connected as shown in the left-hand column of the table, apply rated voltage to the relay and adjust the 50,000-ohm resistor for 0.3 ma. d.c. Now following the procedure in the previous paragraph for the PM-5 relay, adjust the shunts until the left-hand contact closes at 0.3 ma. d.c. Change the connections as indicated in the right-hand column, and adjust the opposite shunt until the right-hand contact closes. Recheck back and forth several times and make necessary trimming adjustments to obtain pickup at 0.3 ma. In each direction. The armature will move gradually as the

current is changed for this relay unit.

ICS Unit

Close the main relay tripping contact circuit with a jumper connected directly across the contact terminals of the polar unit. Pass sufficient direct current through the relay trip circuit to close the contacts of the ICS unit. This value of current should not be greater than the ICS tap setting being used (0.2 or 2.0). The indicator target should drop freely. The contact gap should be approximately 0.047 inch between the bridging moving contact and the adjustable stationary contacts. The bridging moving contact should touch both stationary contacts simultaneously.

RENEWAL PARTS

Repair work can be done most satisfactorily at the factory. However, interchangeable parts can be furnished to the customers who are equipped for doing repair work. When ordering parts, always give the complete nameplate data.

Ground Alarm (5) Calibration		
Relay	<u>Relay Terminals</u>	
	L.H. Contact Check	R.H. Contact Check
PMA	3 ⁺ and 6	3 and 7 ⁺
PMD	5 ⁺ and 6	5 and 7 ⁺
PMG-13	3 ⁺ and 8	3 and 9 ⁺

+ Milliammeter positive to this terminal

INDEX TO FIGURES
INTERNAL SCHEMATICS

FIG. NO.		PAGE NO.
1	Polar Unit Permanent Magnet Flux Paths	2
2	PMA Relay - AC supply - two terminal line	14
3	PMA-1 Relay - AC supply - two terminal line	14
4	PMA Relay - AC supply - three terminal line	14
5	PMA-1 Relay - AC supply - three terminal line	14
6	PMD Relay - DC supply - two terminal line	15
7	PMD-1 Relay - DC supply - two terminal line	15
8	PMD Relay - DC supply - three terminal line	15
9	PMD-1 Relay - DC supply - three terminal line	15
10	PM-2 relay in FT21 case	16
11	PM-3 relay in FT11 case	16
12	PM-4 relay (auxiliary unit)	16
13	PM-5 ground detector relay	16
14	PM-23 relay in FT21 case	17
15	PM-13 Relay - DC supply - two terminal line	17
16	PM-13 Relay - DC supply - three terminal line	17
17	PM-13 Relay - AC supply - two or three terminal line	17
18	PMG-13 Relay - DC supply - two terminal line	18
19	PMG-13 Relay - DC supply - three terminal line	18
20	PMG-13 Relay - AC supply - two or three terminal line	18

EXTERNAL SCHEMATICS

21	PMD relay with PM-23 or PM-4, two terminal line	19
22	PMA relay with PM-23 or PM-4, two terminal line	19
23	DC type PMG-13 with PM-23 or PM-4, two terminal line	20
24	PMD relay with PM-23 & PM-4, three terminal line	20
25	AC type PMG-13 relay with PM-23, two terminal line	21
26	DC type PM-13 & PM-5 with PM-23 or PM-4, two terminal line	21
27	DC type PM-13 relay with PM-23 or PM-4, two terminal line	22

OUTLINE & DRILLING PLANS

28	10 mfd. capacitor	23
29	Remote trip resistor	23
30	PM-4 projection molded case	23
31	PM-4 semi-flush molded case	23
32	PM-3, PM-5, & PMD-1 in FT11 case	24
33	PM-2, PM-23, PMA-1, & PMD in FT21 case	25
34	PMA in FT31 case	26
35	PM-13 and PMG-13 in FT32 case	27

TYPE PM MONITORING RELAYS

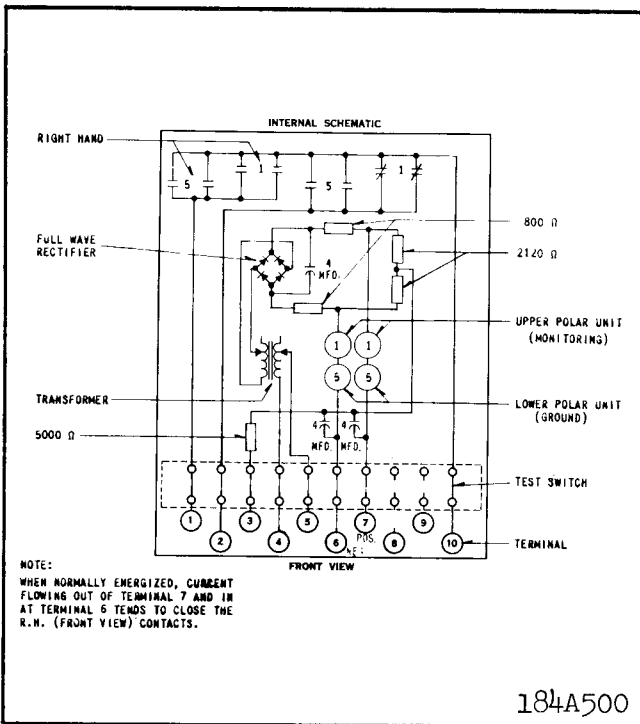

Fig. 2. Internal schematic of the type PMA relay in FT 31 case - 120 volt, 60 cycle supply - For two terminal lines.

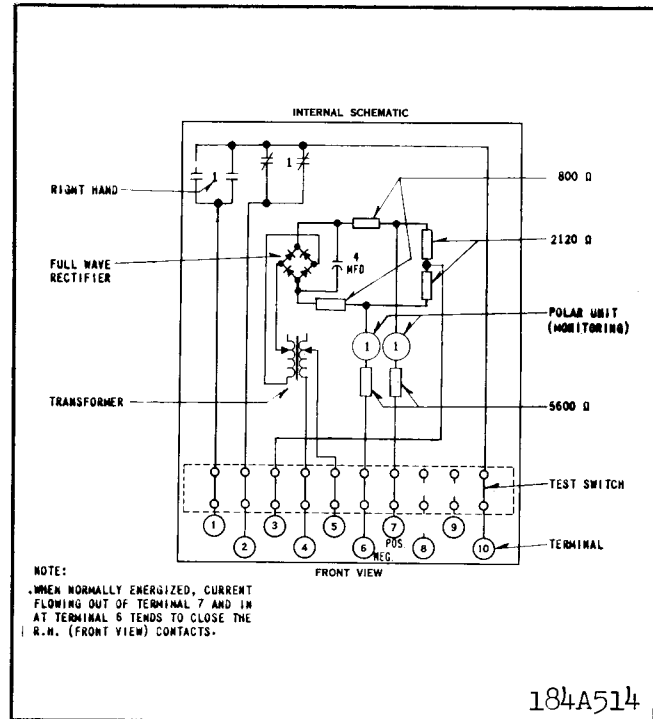

Fig. 3. Internal schematic of type PMA-1 relay in the FT 21 case - 120 volts, 60 cycle supply - For two terminal lines.

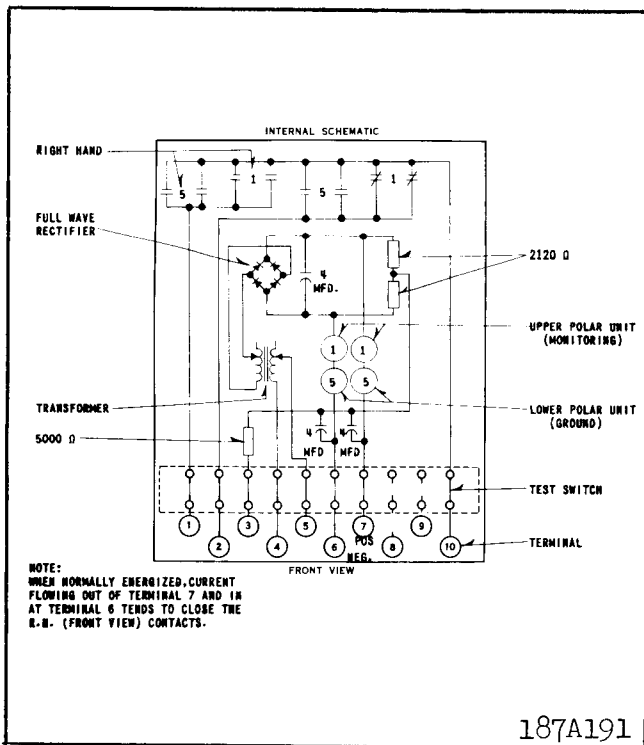

Fig. 4. Internal schematic of type PMA relay in FT 31 case - 120 volt, 60 cycle supply - For three terminal lines.

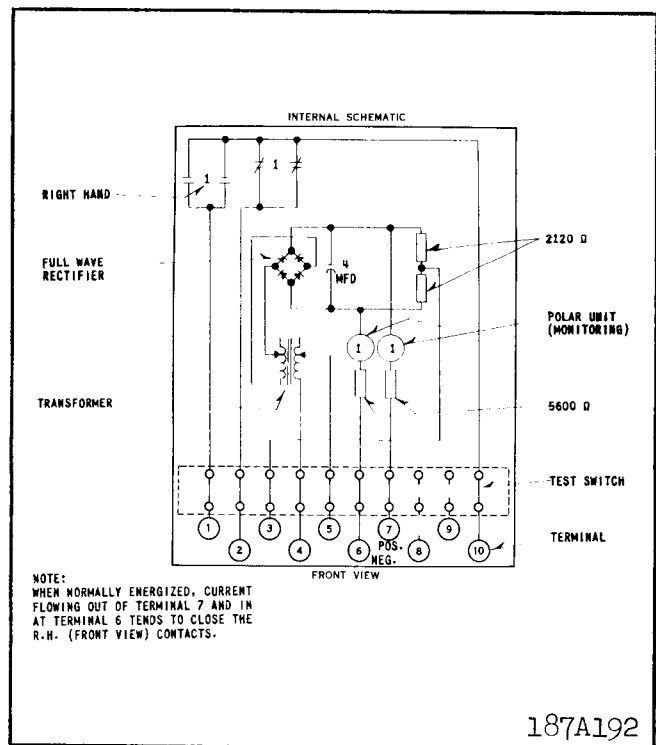

Fig. 5. Internal schematic of type PMA-1 relay in FT 21 case - 120 volt, 60 cycle supply - For three terminal lines.

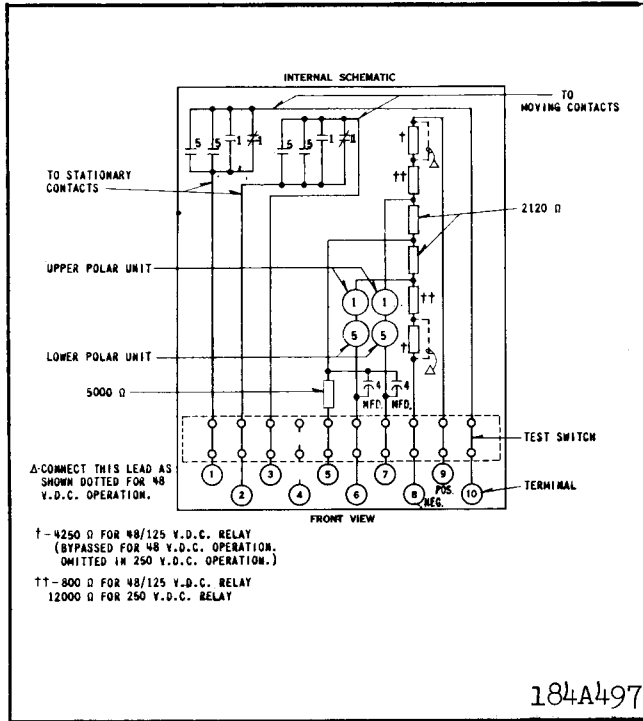

Fig. 6. Internal schematic of the type PMD relay in FT 21 case - DC supply - for two terminal lines.

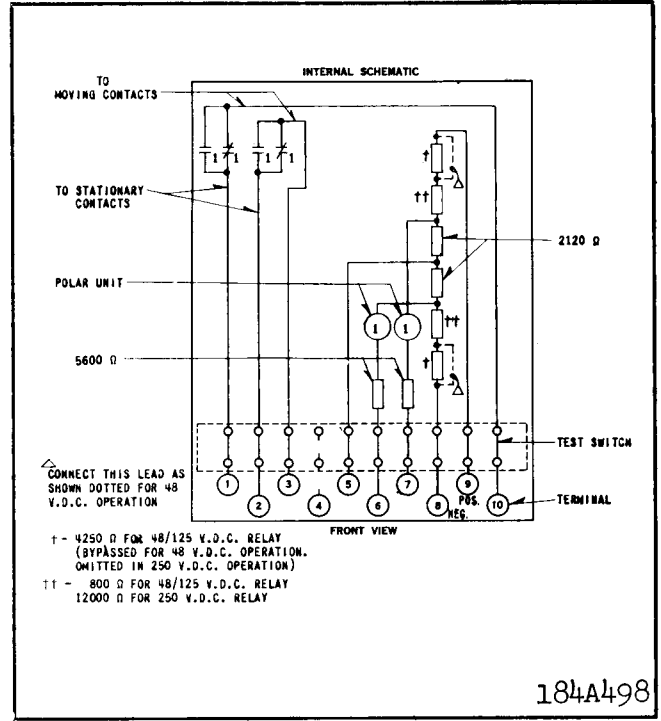

Fig. 7. Internal schematic of the type PMD-1 relay in the FT 11 case - DC supply - For two terminal lines.

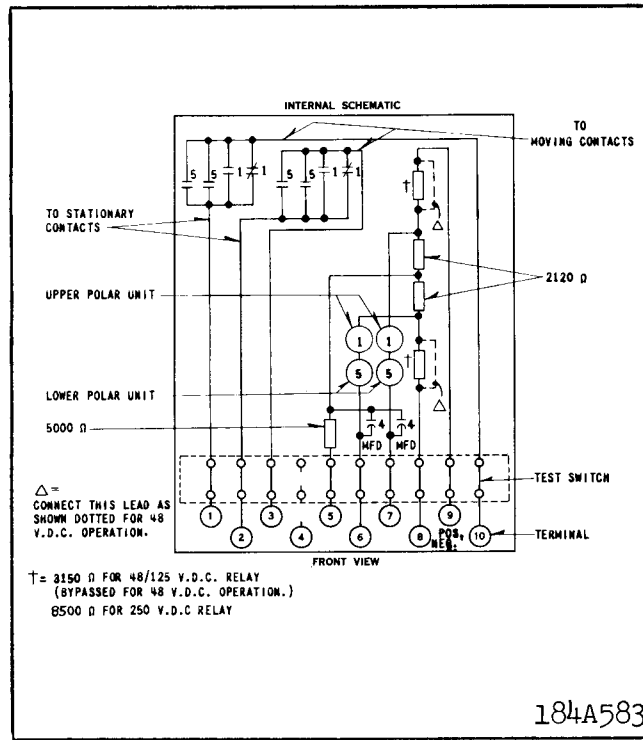

Fig. 8. Internal schematic of the type PMD relay in the FT 21 case - DC supply - For three terminal lines.

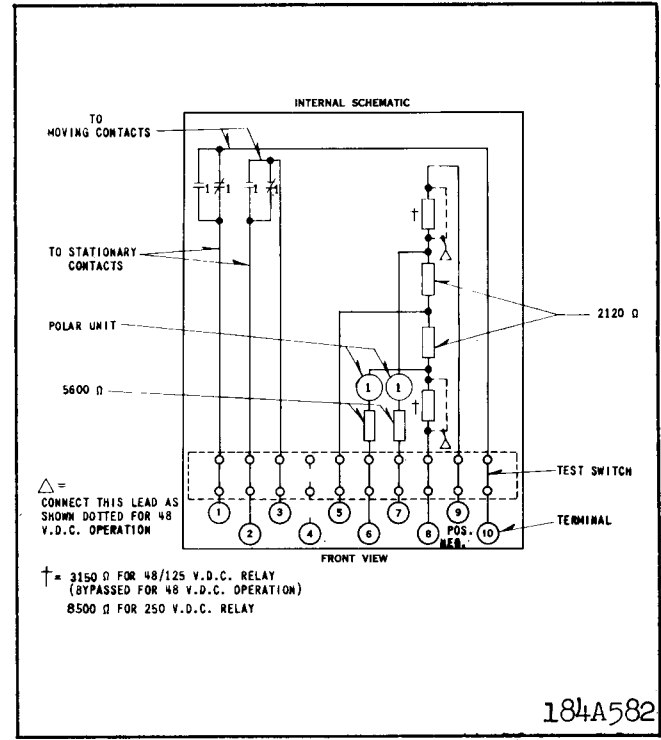

Fig. 9. Internal schematic of the type PMD-1 relay in the FT 11 case - DC supply - For three terminal lines.

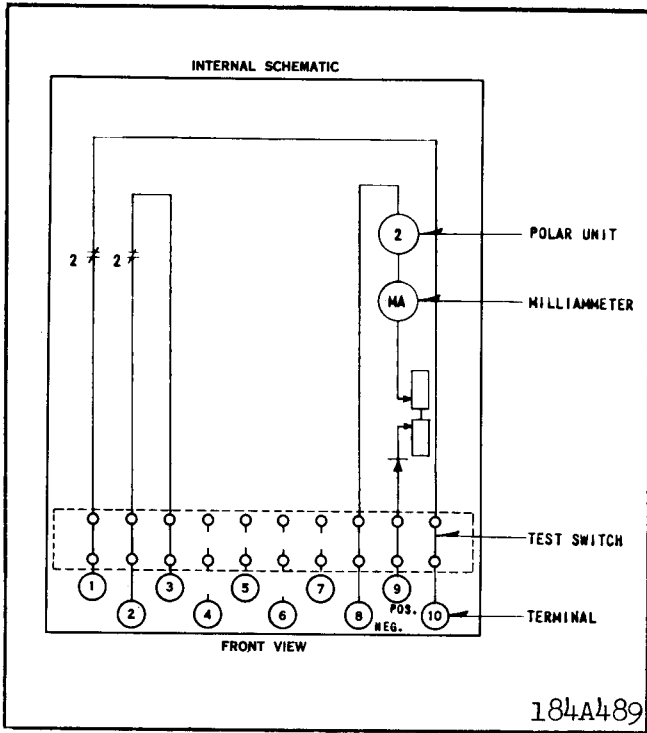

Fig. 10. Internal schematic of the type PM-2 relay in the FT 21 case.

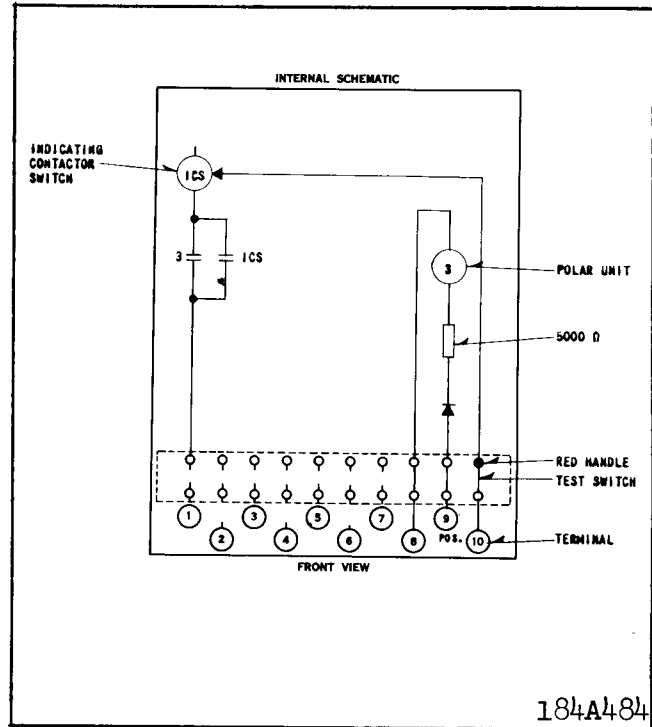

Fig. 11. Internal schematic of the type PM-3 relay in the FT 11 case.

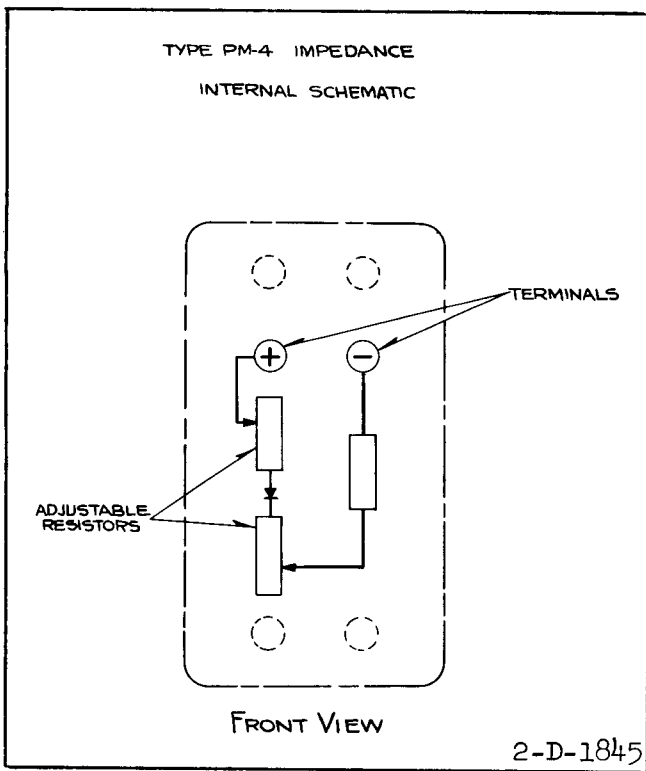

Fig. 12. Internal schematic of the type PM-4 Auxiliary Unit in the small molded case.

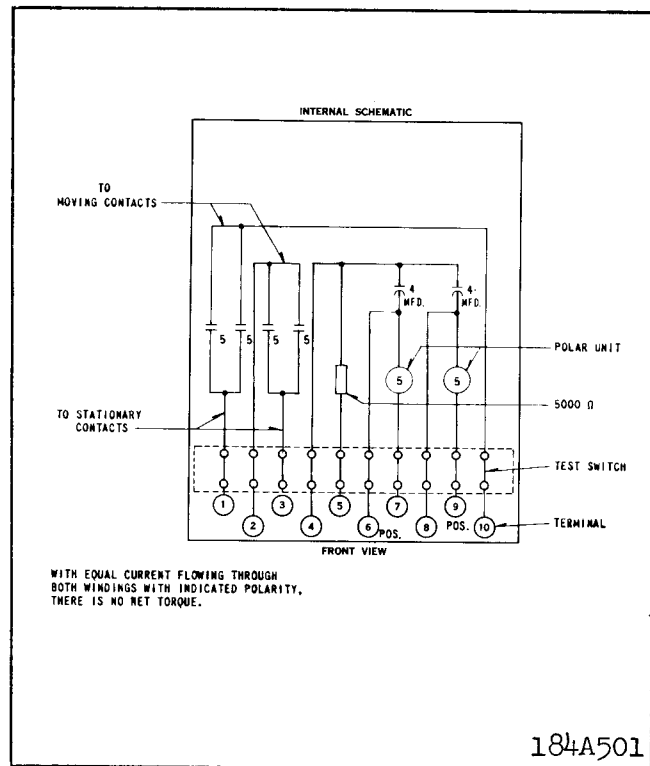
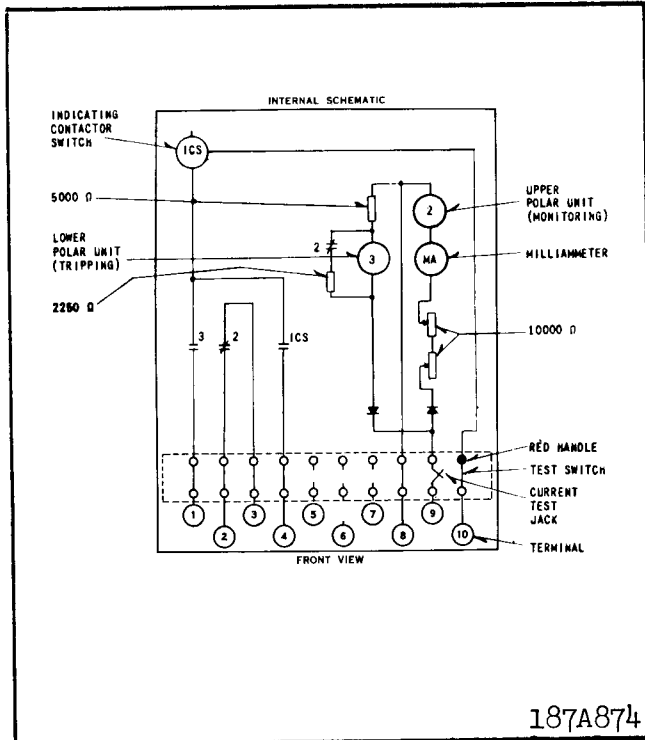
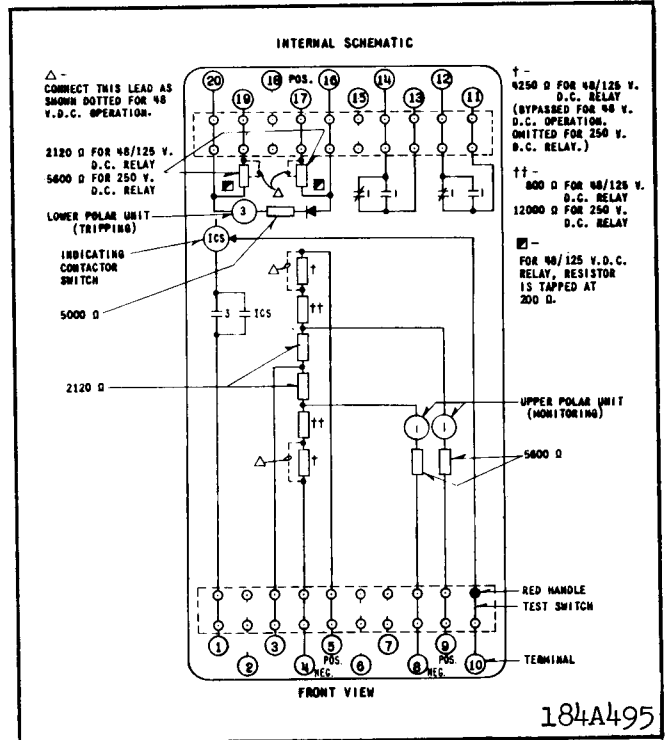

Fig. 13. Internal schematic of the type PM-5 ground detector relay in the FT 11 case.



187A874

Fig. 14. Internal schematic of the type PM-23 relay in the FT 21 case.



184A495

Fig. 15. Internal schematic of the type PM-13 relay in the FT 32 case - DC supply - For two terminal lines.

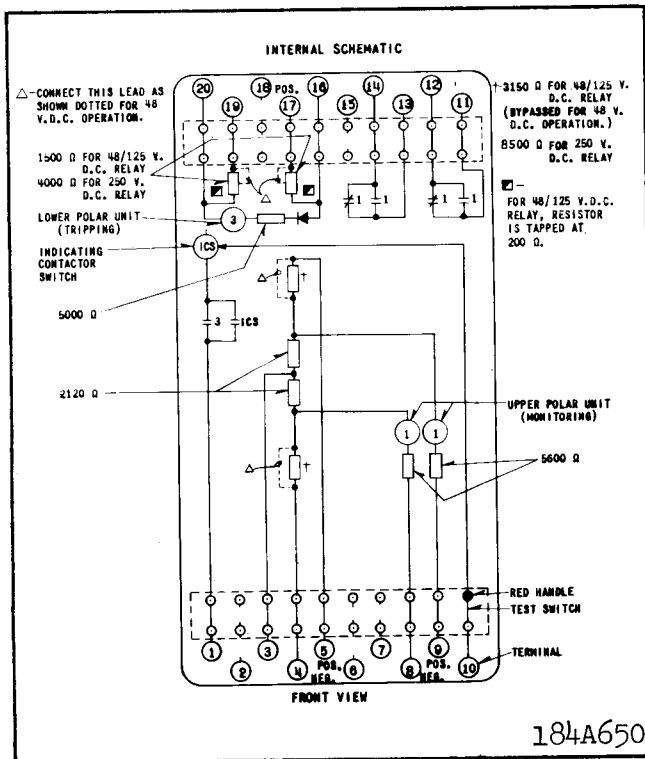

184A650

* Fig. 16. Internal schematic of the type PM-13 relay in the FT 32 case - DC supply - For three terminal lines.

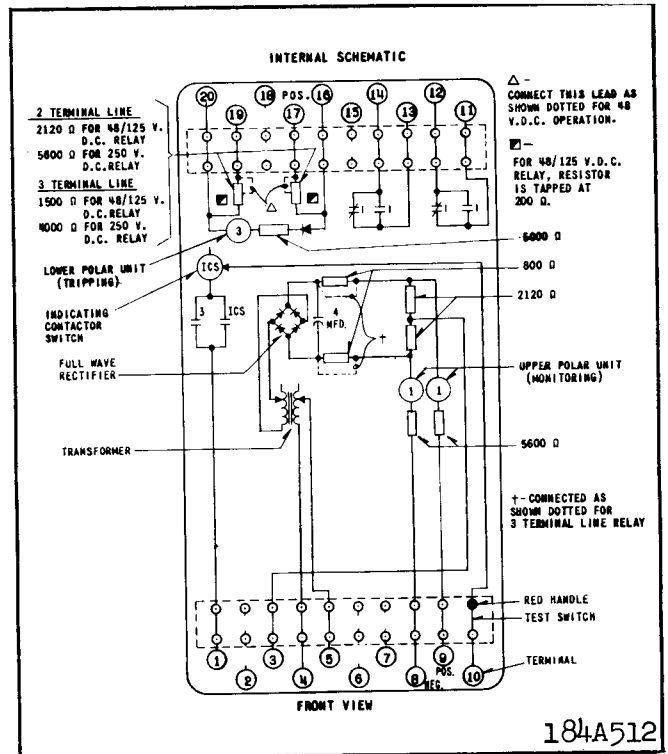

184A512

Fig. 17. Internal schematic of the type PM-13 relay in the FT 32 case - 120 volt, 60 cycle supply - For two or three terminal lines.

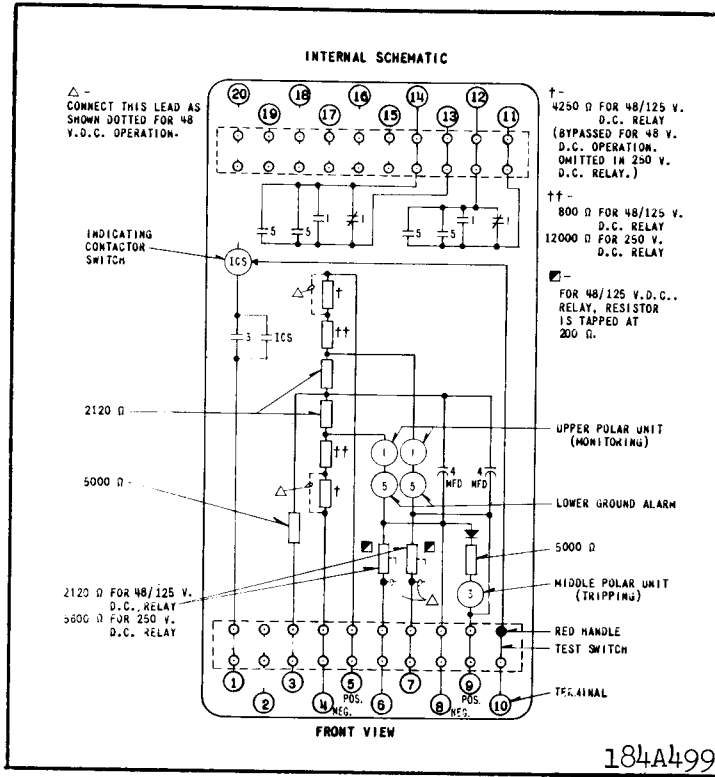

Fig. 18. Internal schematic of the type PMG-13 relay in the FT 32 case - DC supply - For two terminal lines.

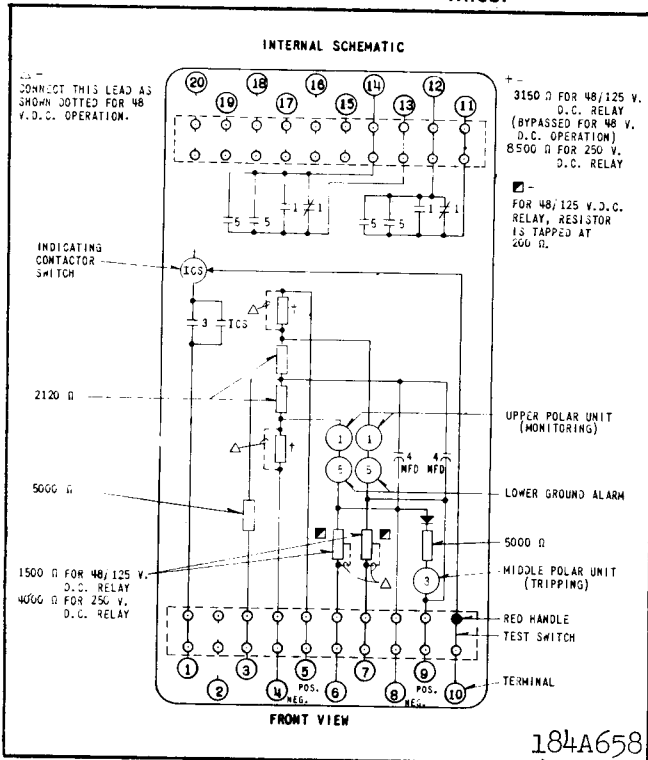

Fig. 19. Internal schematic of the type PMG-13 relay in the FT 32 case - DC supply - For three terminal lines.

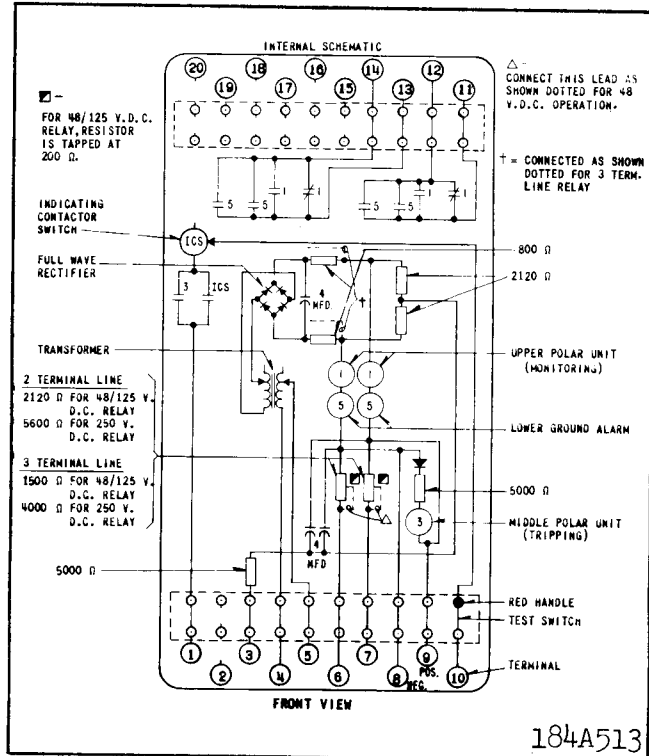

Fig. 20. Internal schematic of the type PMG-13 relay in the FT 32 case - 120 volt, 60 cycle supply - For two or three terminal lines.

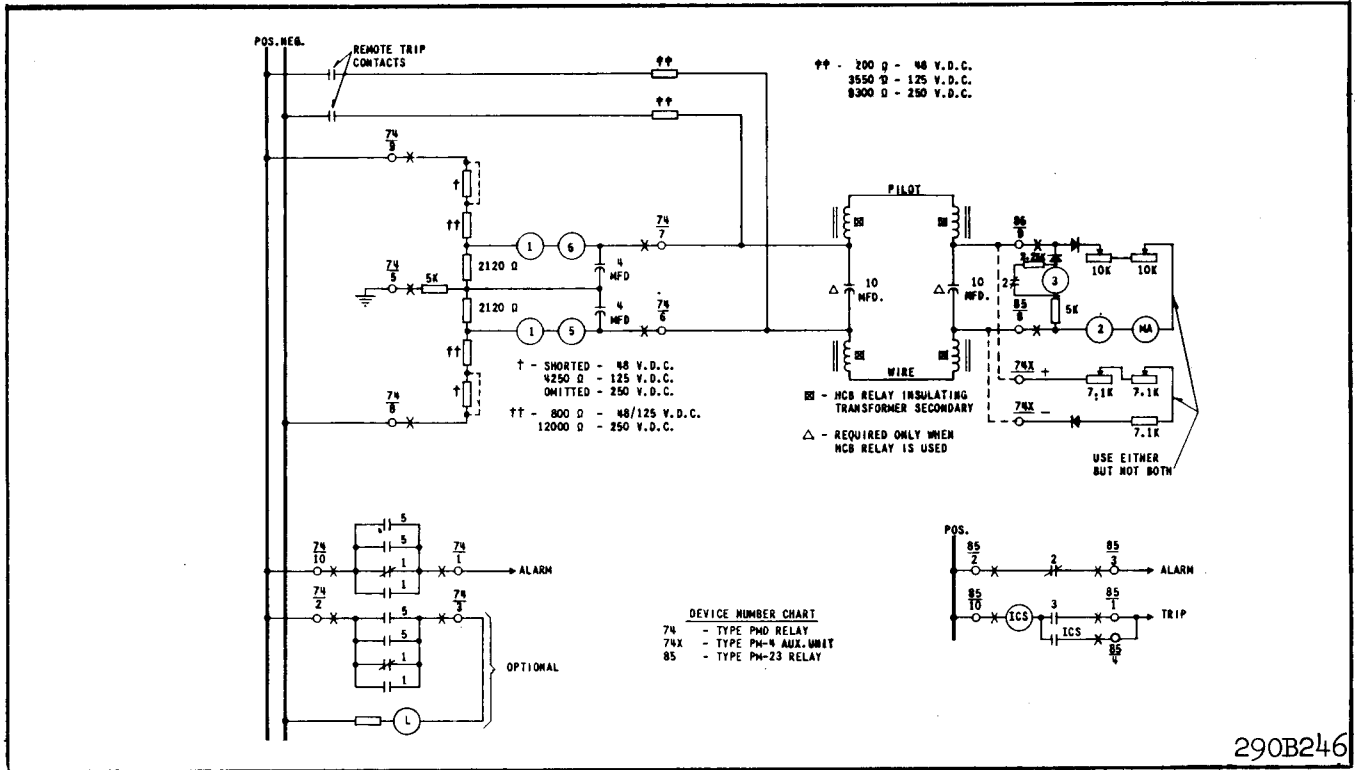

Fig. 21. External schematic of the type PMD relay with type PM-23 or PM-4 relay – Two terminal lines.

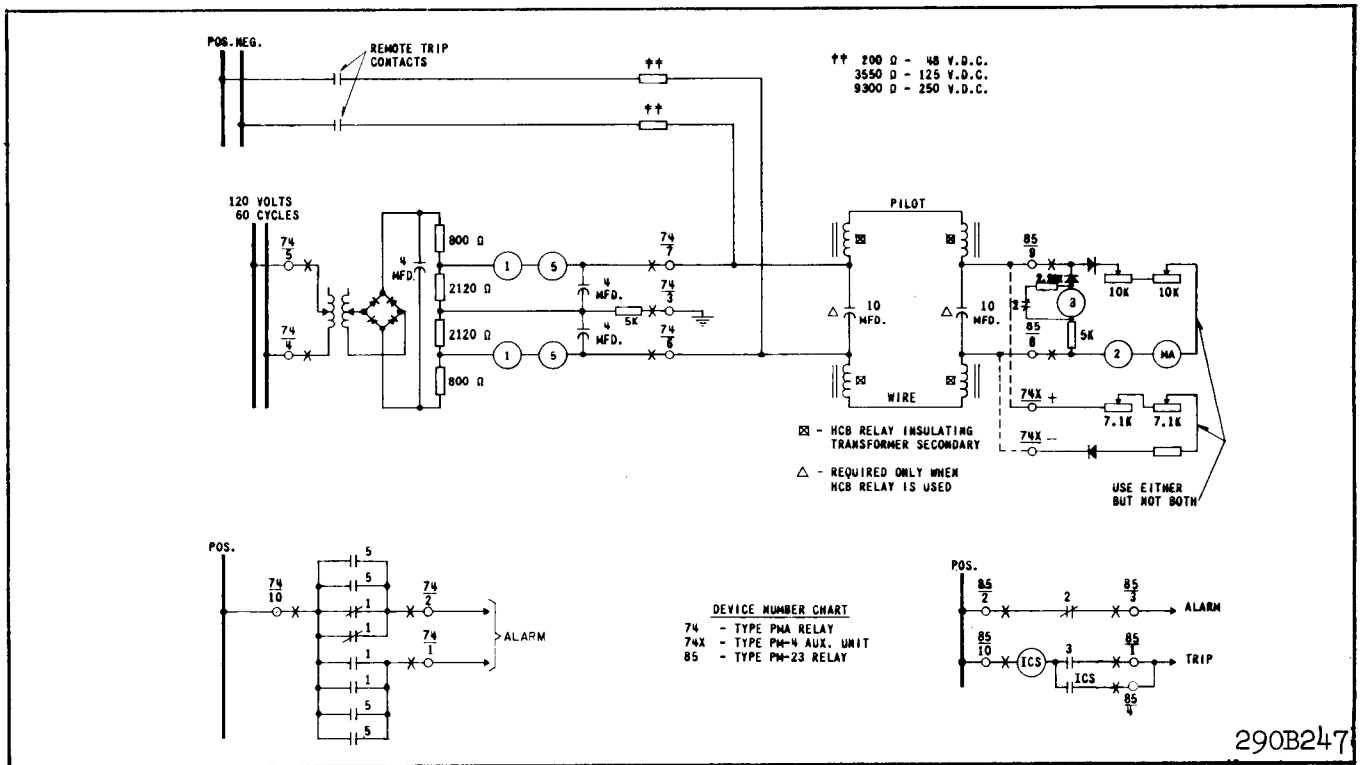

Fig. 22. External schematic of the type PMA relay with type PM-23 or PM-4 relay – Two terminal lines.

TYPE PM MONITORING RELAYS

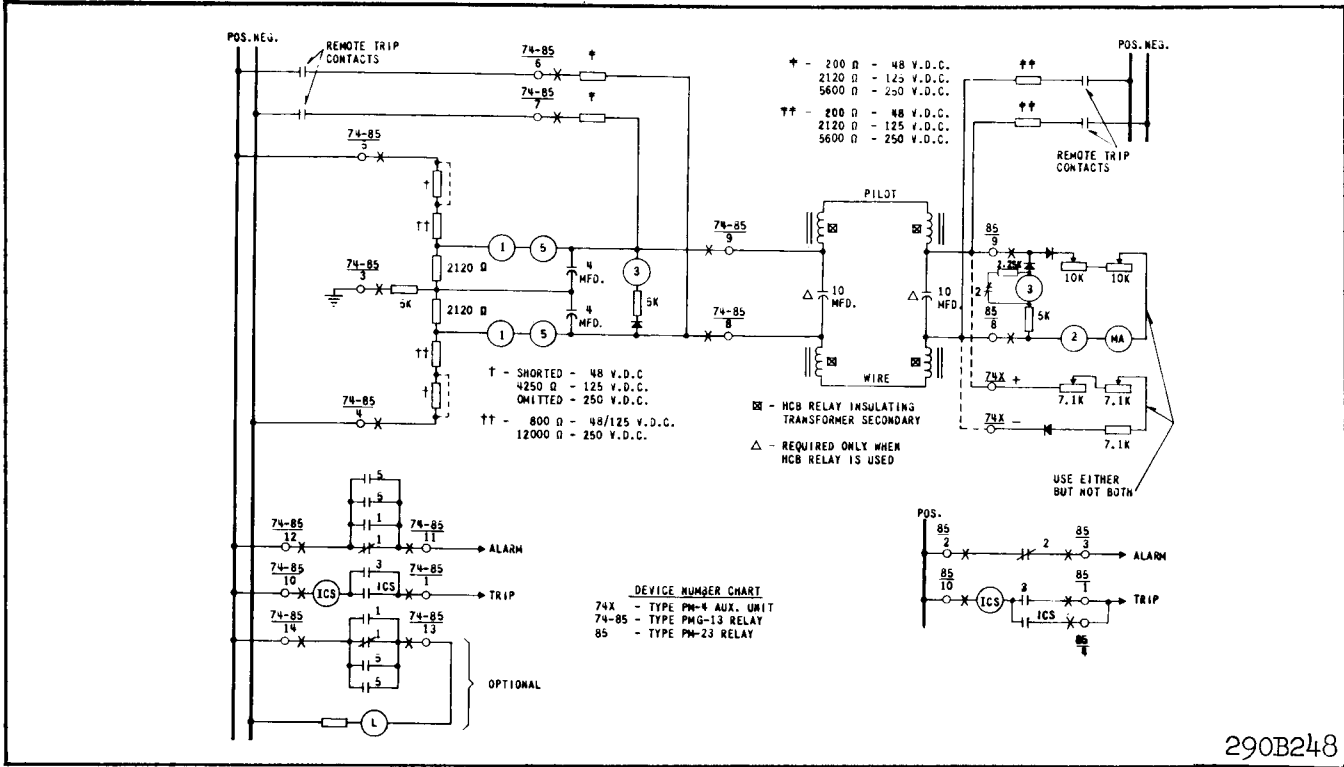

Fig. 23. External schematic of the DC type PMG-13 relay with type PM-23 or PM-4 relay – Two terminal lines.

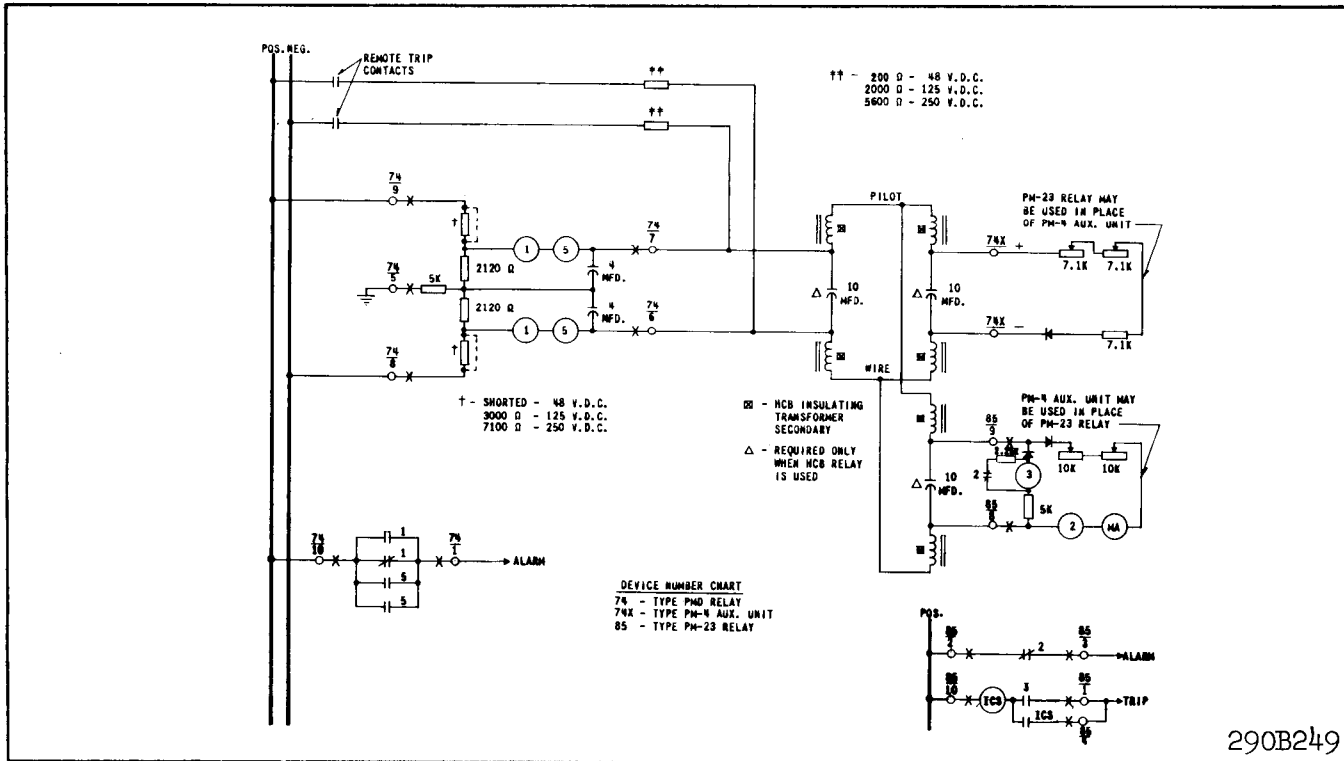

Fig. 24. External schematic of the type PMD relay with type PM-23 and PM-4 relays – Three terminal lines.

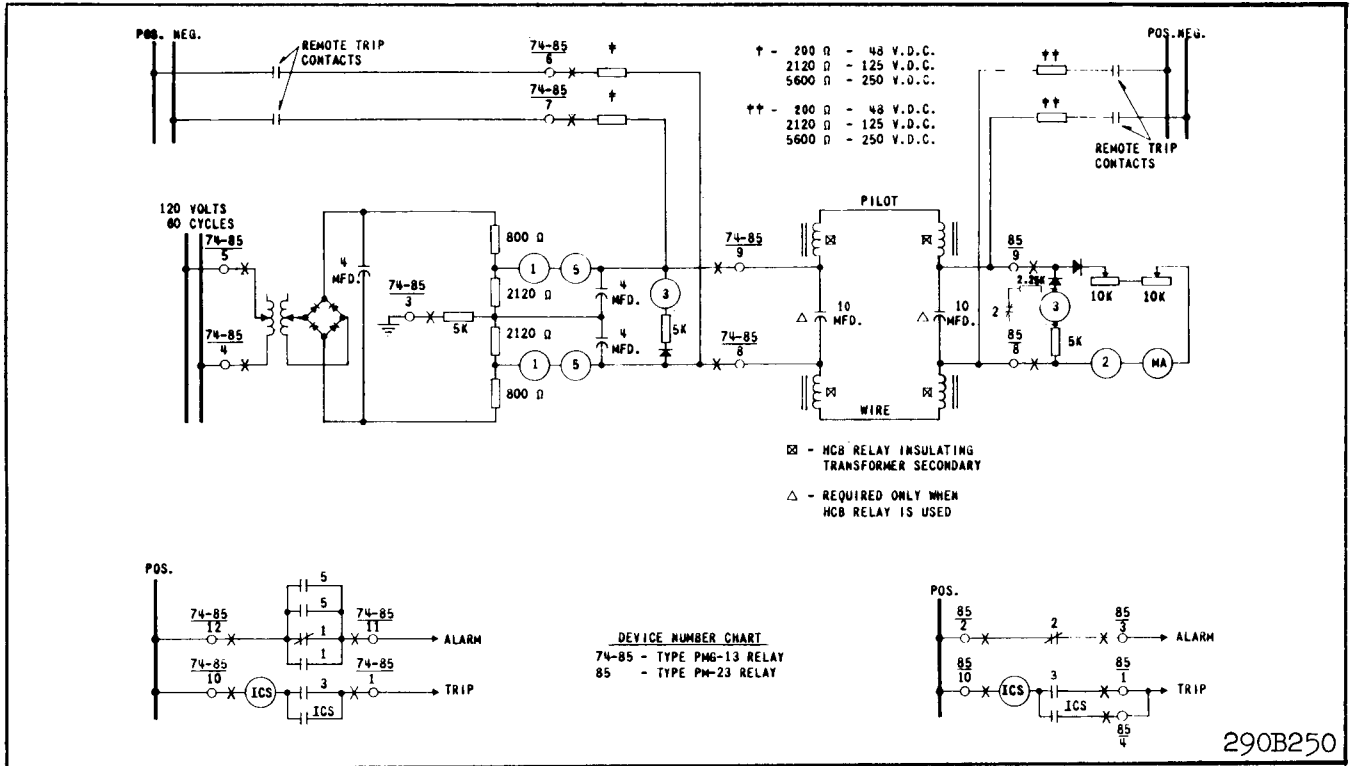

Fig. 25. External schematic of the AC type PMG-13 with type PM-23 relay - Two terminal lines.

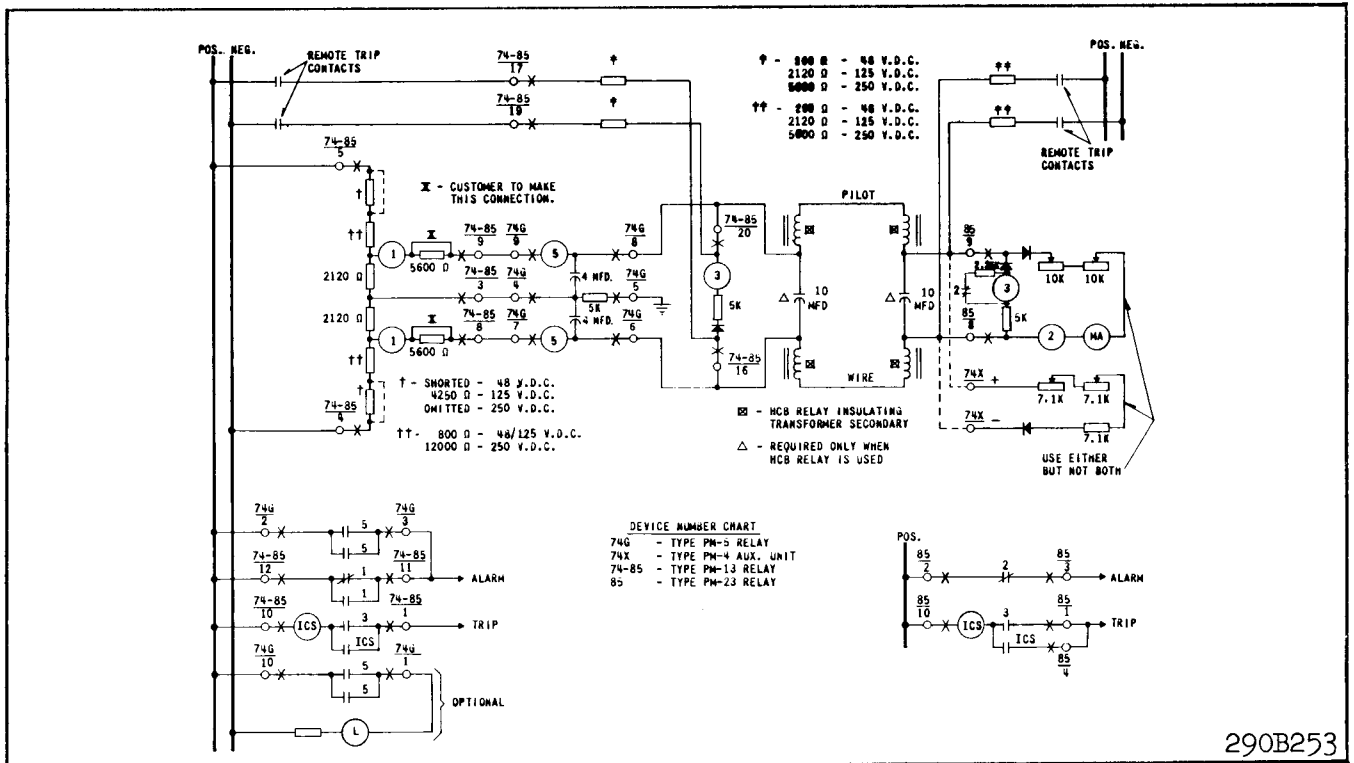

Fig. 26. External schematic of the DC type PM-13 and PM-5 relay with type PM-23 or PM-4 relay - Two terminal lines.

TYPE PM MONITORING RELAYS

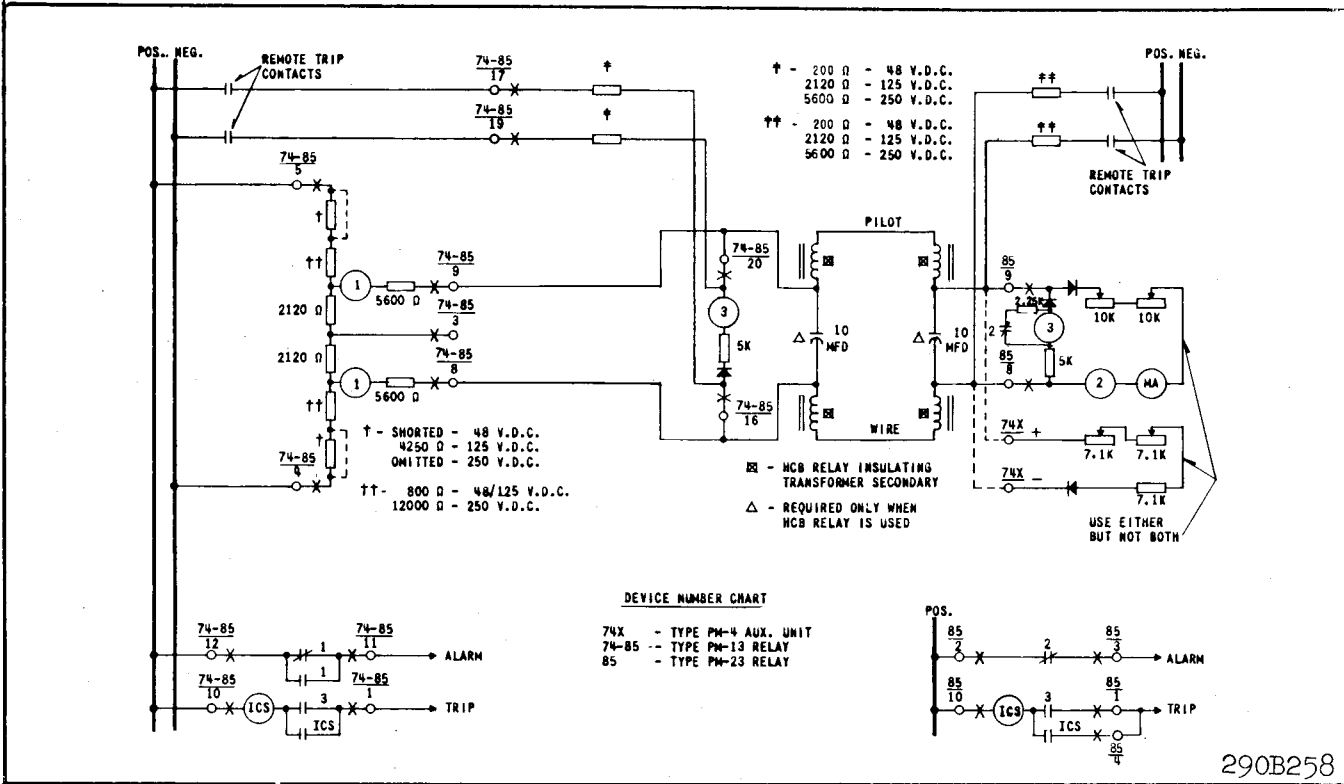

Fig. 27. External schematic of the DC type PM-13 relay with type PM-23 or PM-4 relay – Two terminal lines.

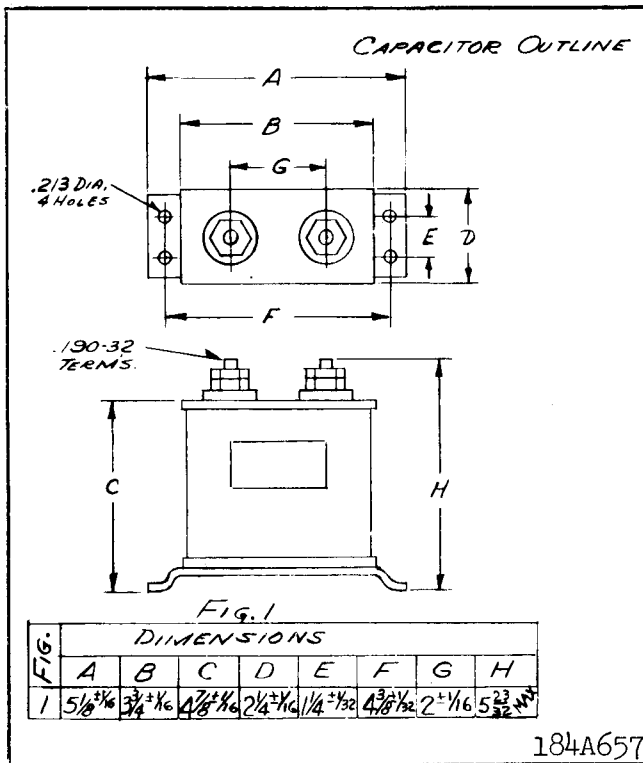

Fig. 28. Outline and Drilling Plan for 10 mfd. capacitor - For reference only.

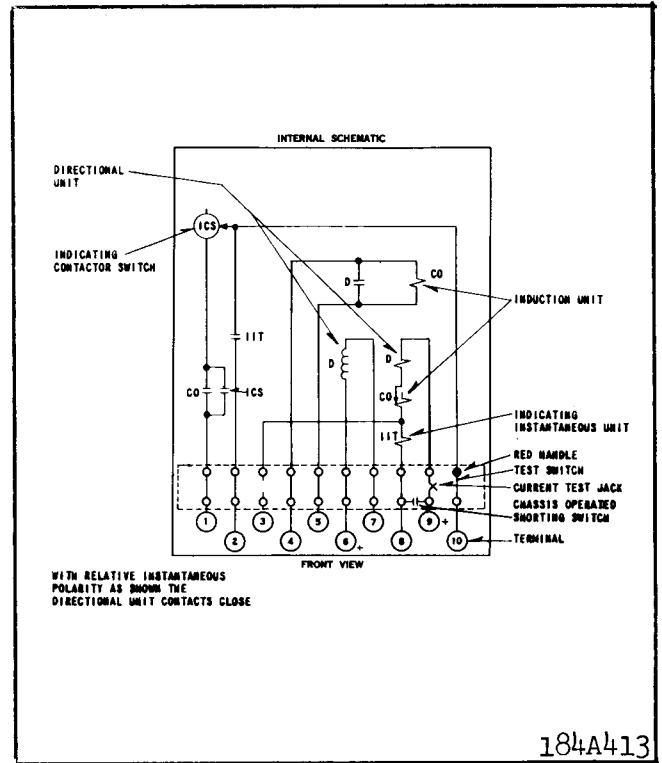

Fig. 29. Outline and Drilling Plan for External Remote trip Resistor Assembly.

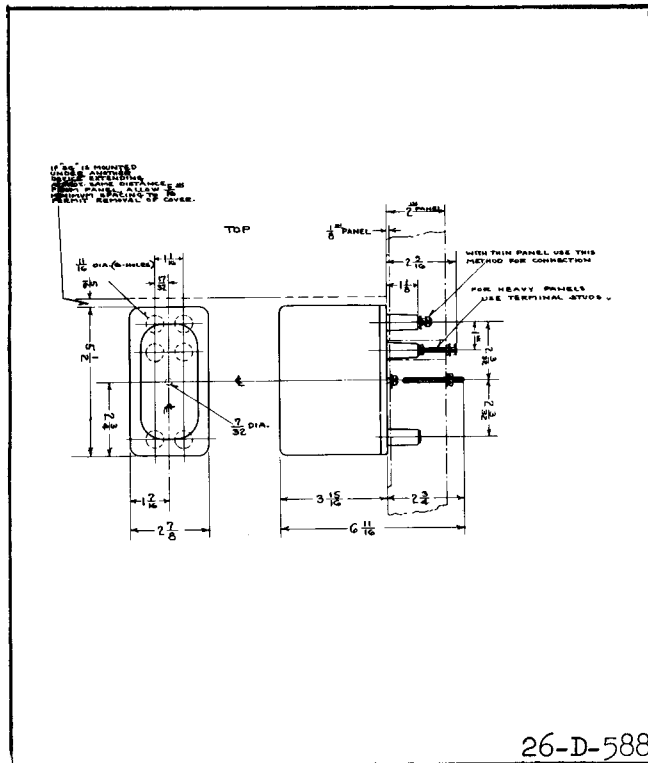

Fig. 30. Outline and Drilling Plan for the type PM-4 Auxiliary unit in the projection molded case.

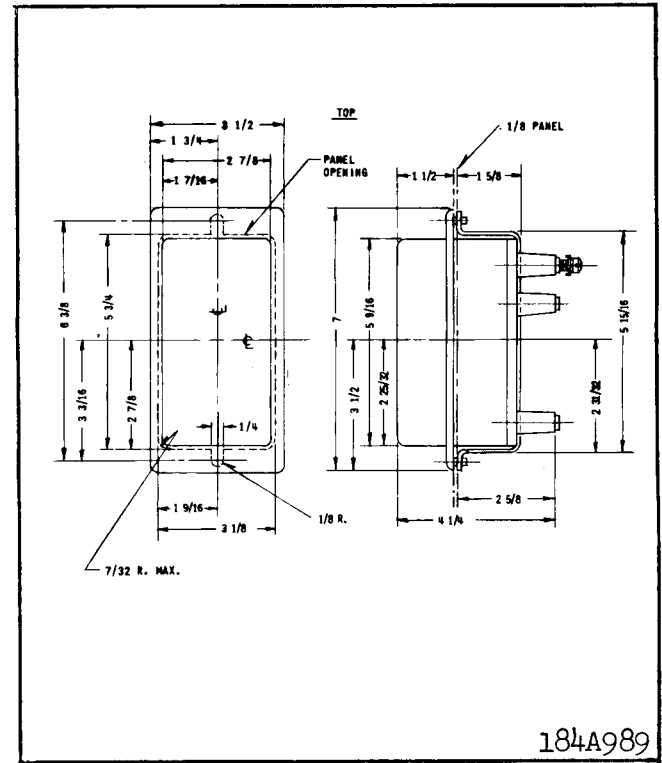

Fig. 31. Outline and Drilling Plan for the type PM-4 Auxiliary unit in the Semi-Flush molded case.

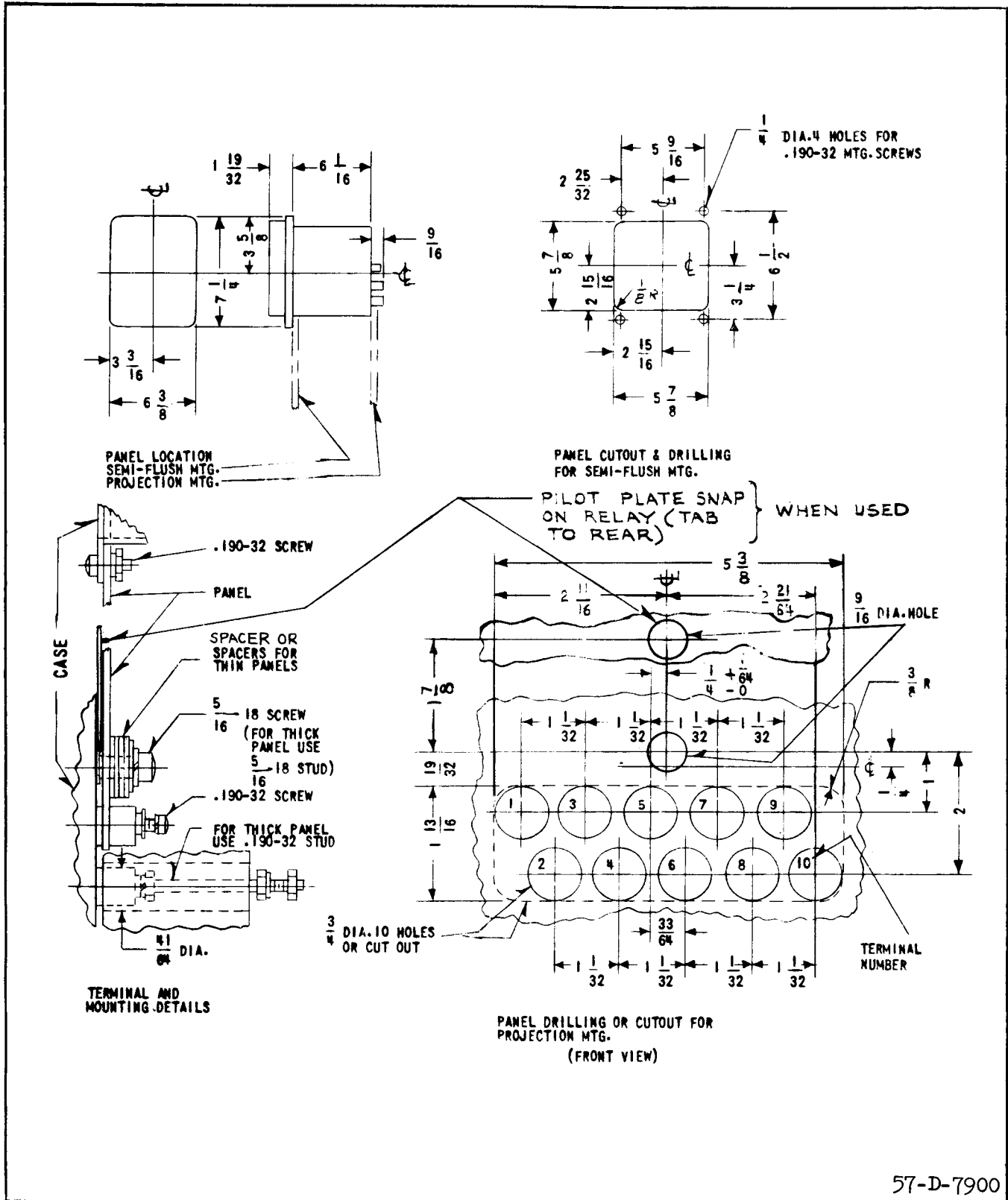
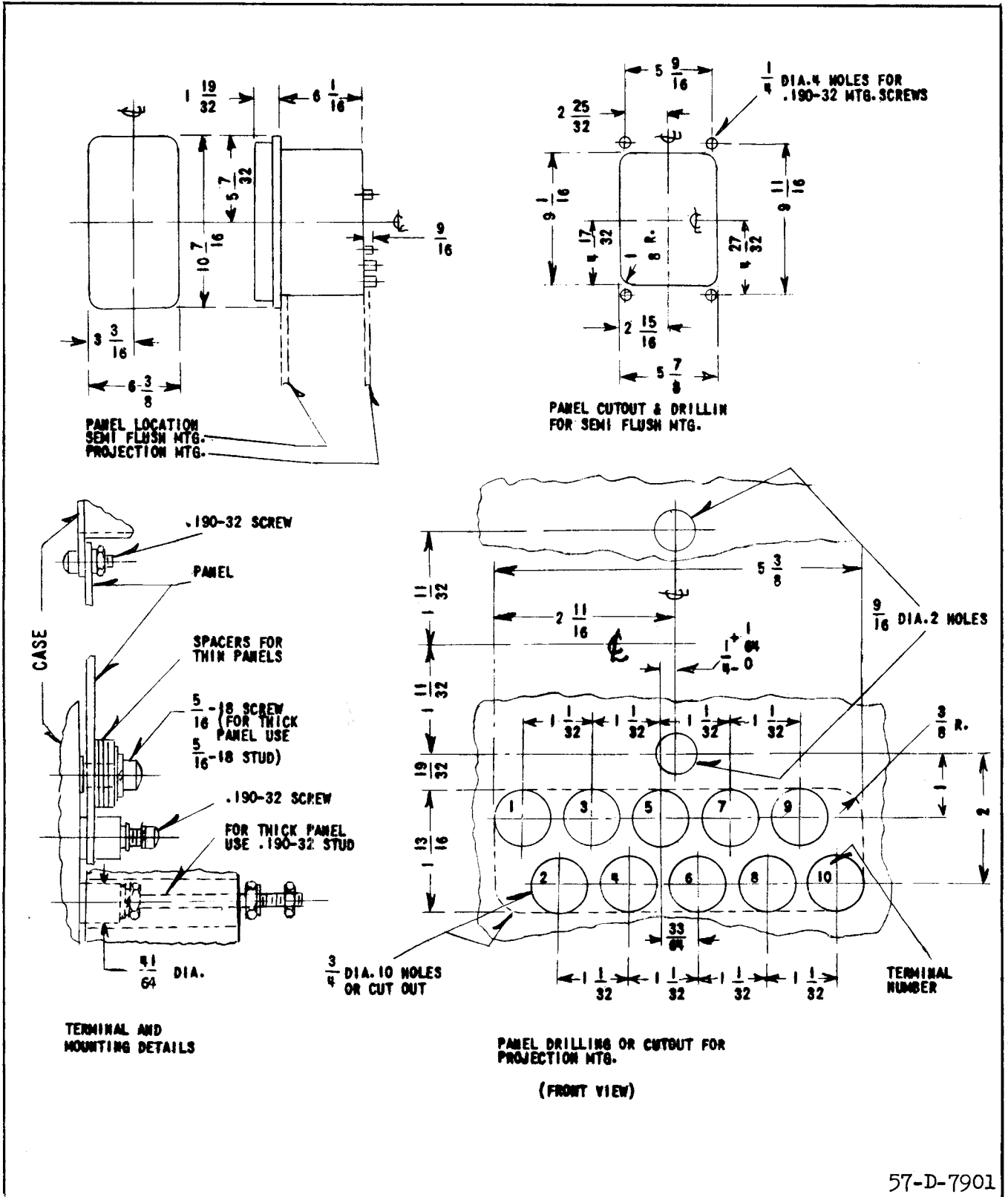
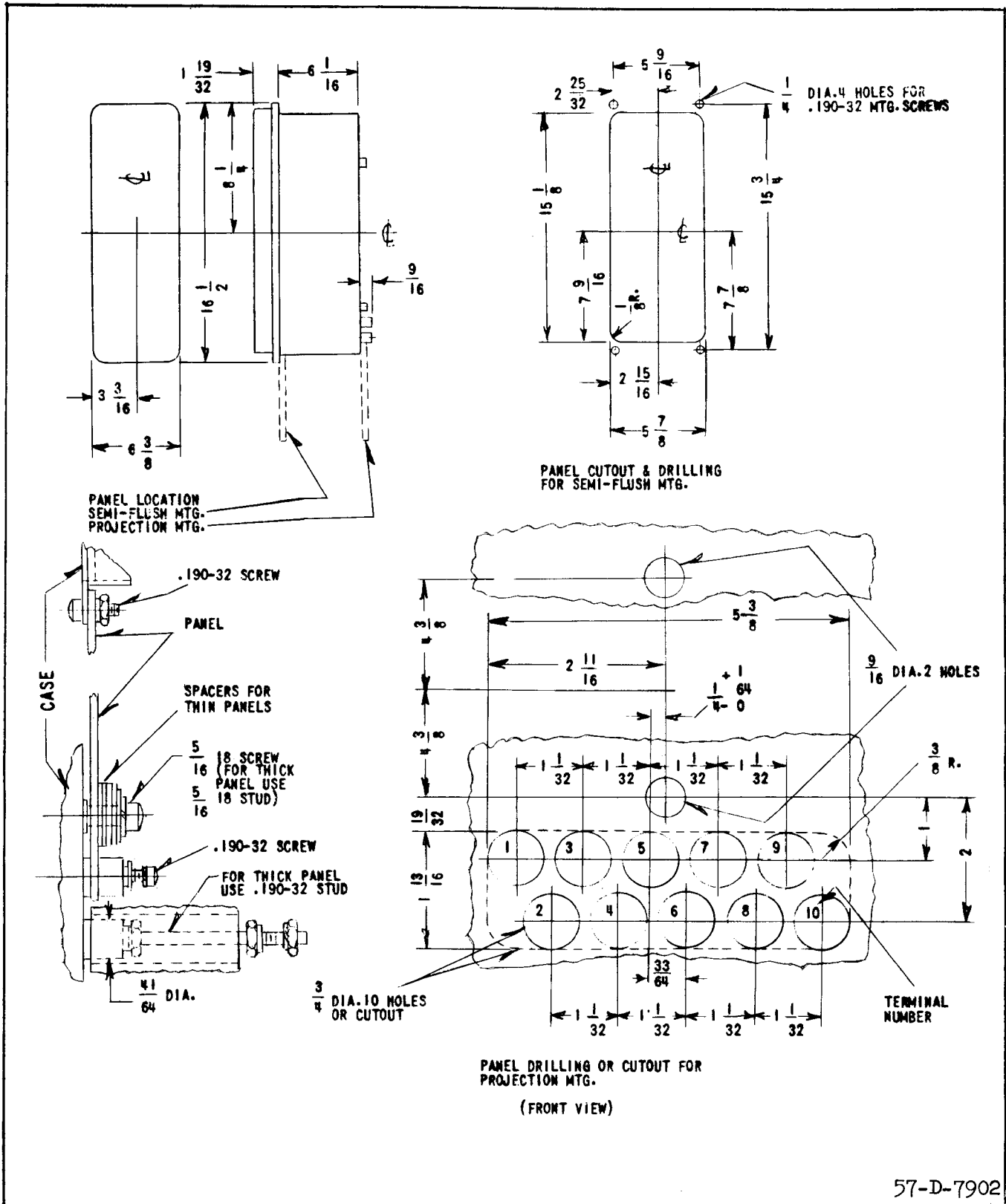

Fig. 32. Outline and Drilling Plan for the type PM-3, PM-5, & PMD-1 Relays in the type FT 11 case.



57-D-7901

Fig. 33. Outline and Drilling Plan for the type PM-2, PM-23, PMA-1 and PMD relays in the type FT 21 case.



57-D-7902

Fig. 34. Outline and Drilling Plan for the type PMA relay in the type FT 31 case.

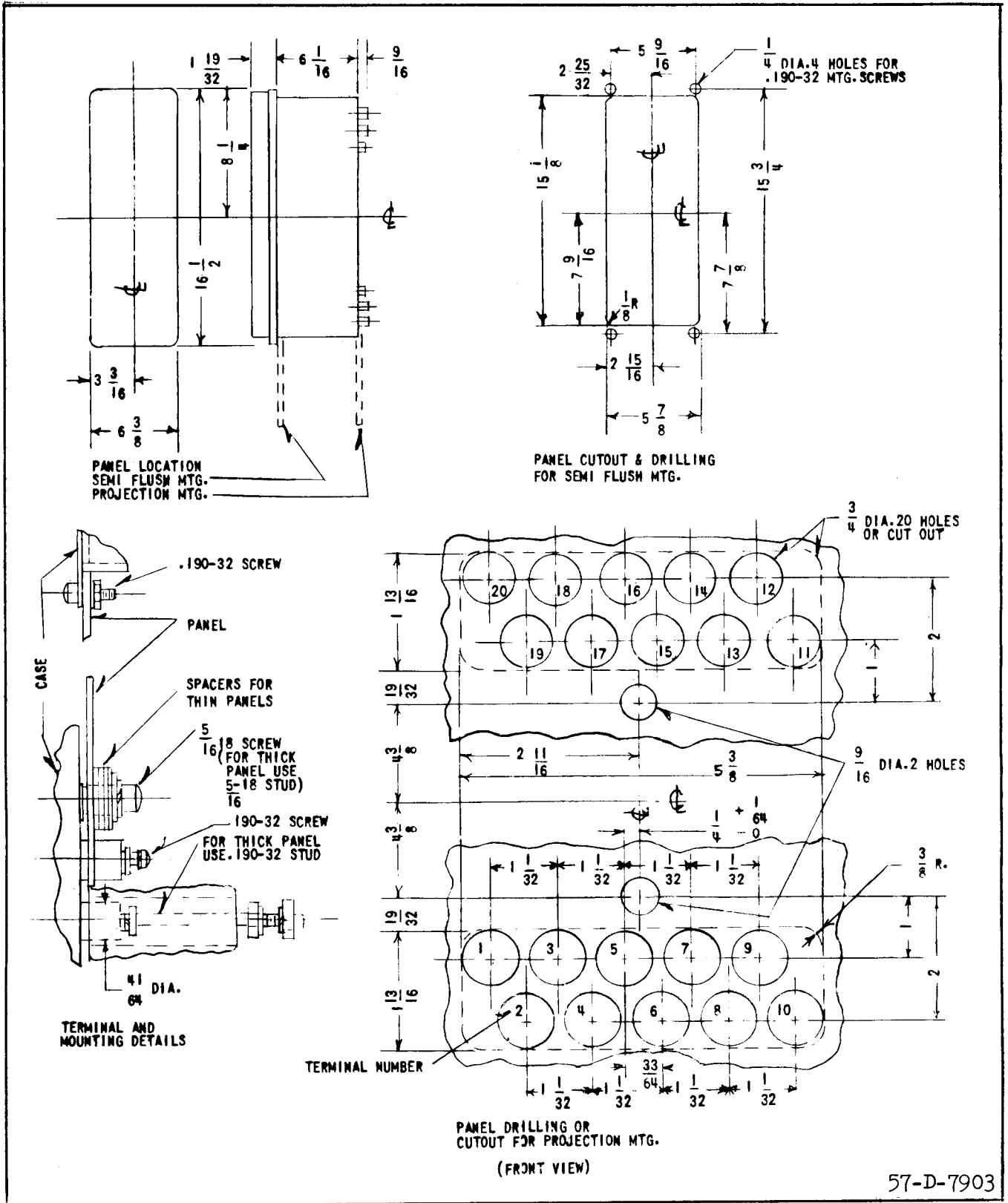
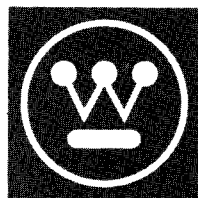

Fig. 35. Outline and Drilling Plan for the type PM-13 and PMG-13 relays in the type FT 32 case.



WESTINGHOUSE ELECTRIC CORPORATION
RELAY-INSTRUMENT DIVISION

NEWARK, N. J.

Printed in U.S.A.



INSTALLATION • OPERATION • MAINTENANCE INSTRUCTIONS

TYPE PM LINE OF RELAYS FOR PILOT-WIRE MONITORING AND TRANSFERRED TRIPPING

CAUTION Before putting protective relays into service, remove all blocking which may have been inserted for the purpose of securing parts during shipment, make sure that all moving parts operate freely, inspect the contacts to see that they are clean and close properly, and operate the relay to check the settings and electrical connections.

APPLICATION

Type PM Monitoring Relays provide continuous monitoring of a pilot-wire circuit to detect open circuits, short circuits, grounds, and wire reversal. In addition, transferred tripping can be effected where the PM-3, PM-13, PMG-13 or PM-23 relays are used. Table I illustrates the functions available with each relay. A 10 mfd. capacitor is supplied with each PM relay. This capacitor provides an a-c path between the two halves of the insulating transformer secondary windings as shown in Figs. 21 through 27.

Each circuit requires the following:

At one end to introduce monitoring current

One of the following:

For a-c Supply

For d-c Supply

PMA	PMD
PMA-1	PMD-1
PM-13 or PMG-13 (a.c.)	PM-13 or PMG-13 (d.c.)

At the other end to receive monitoring current (two-terminal line)

One PM-23 or PM-2 or PM-4

At the other ends to receive monitoring current (three-terminal line)

Two PM-23 or two PM-4 or two PM-2 or any combination of two of these relays.

CONSTRUCTION

PM relays consist of the following:

<u>PMA</u>	<u>PMA-1</u>
1-Polar Alarm Unit (1)	1-Polar Alarm Unit

1-Polar Ground Unit (5)
1-Tapped Transformer
1-Full-Wave Rectifier
3-4 mfd. Capacitors
1-Set of Voltage
Dividing Resistors

PMD

1-Polar Alarm Unit (1)
1-Polar Ground Unit (5)
2-4 mfd. Capacitors
1-Set of Potential
Divider Resistors

PMG-13

1-Polar Alarm Unit (1)
1-Polar Ground Unit (5)
1-Polar Trip Unit (3)
1-Indicating Contactor
Switch
1-Set of Potential
Divider Resistors
1-Tapped Transformer
(A.C. Relay only)
1-Full-Wave Rectifier
(A.C. Relay only)
1-Blocking Rectifier
2-Remote Trip Resistors
3-4 mfd. Capacitors
(A-C Relay)
2-4 mfd. Capacitors
(D-C Relay)

PM-23

1-Polar Alarm Unit (2)
1-Polar Trip Unit (3)
1-Indicating Contactor
Switch (ICS)
1-Milliammeter, 5.0 ma.
1-Set of Adjustable and
Fixed Resistors
2-Blocking Rectifiers

1-Tapped Transformer
1-Full-Wave Rectifier
1-4 mfd. Capacitor
1-Set of Voltage
Dividing Resistors

PMD-1

1-Polar Alarm Unit
1-Set of Potential
Divider Resistors

PM-13

1-Polar Alarm Unit (1)
1-Polar Trip Unit (3)
1-Indicating Contactors
Switch
1-Set of Potential
Divider Resistors
1-Tapped Transformer
(A.C. Relay only)
1-Full-Wave Rectifier
(A.C. Relay only)
1-Blocking Rectifier
2-Remote Trip Resistor
1-4 mfd. Capacitor

PM-2

1-Polar Alarm Unit (2)
1-Milliammeter, 5.0 ma.
1-Set of Adjustable
Resistors
1-Blocking Rectifier

TYPE PM MONITORING RELAYS

PM-3

- 1-Polar Trip Unit (3)
- 1-Resistor
- 1-Blocking Rectifier
- 1-Indicating Contactor Switch (ICS)

PM-4

- 1-Blocking Rectifier
- 1-Set of Adjustable & Fixed Resistors

PM-5

- 1-Polar Ground Unit (5)
- 2-4 mfd. Capacitors
- 1-Fixed Resistor

TABLE I

FUNCTION	PMA & PMD	PMA-1 & PMD-1	PM-13	PMG-13	PM-23	PM-2	PM-3	PM-4	PM-5
Monitoring Current Source	X	X	X	X					
Receives Monitoring Current					X	X		X	
Trouble Alarm	X	X	X	X	X	X			X
Transmits Trip Signal	X †	X †	X	X	X †	X †	X †	X †	
Receives Trip Signal			X	X	X		X		
Sensitive Ground Detection	X			X					X
Measures Monitoring Current					X	X			

† With External Resistors

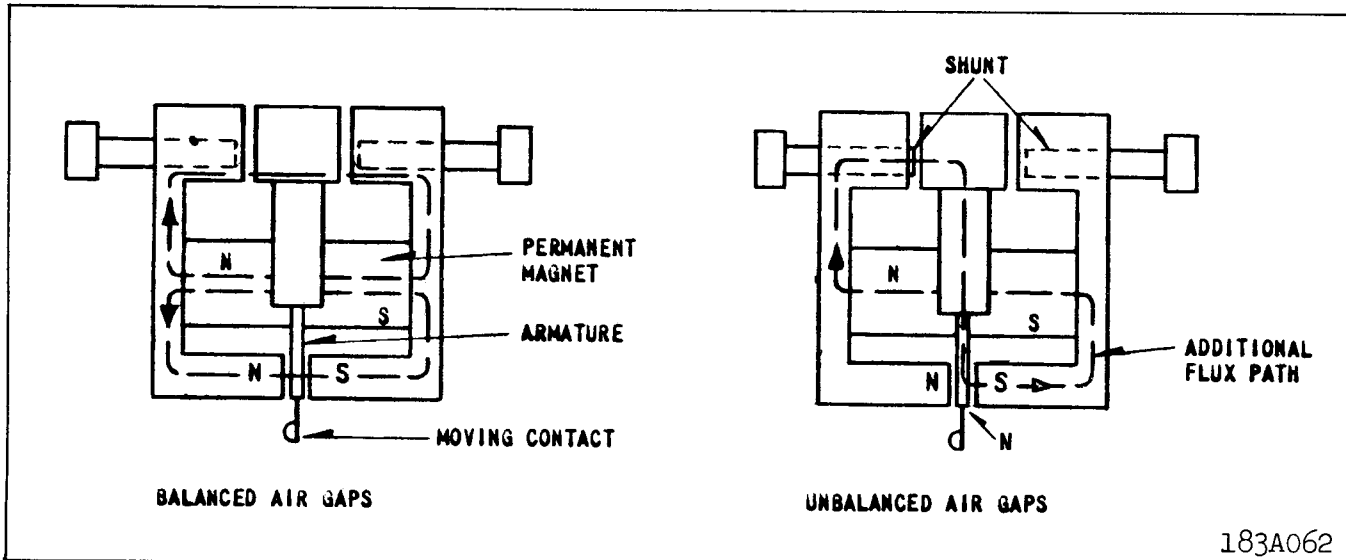

Fig. 1. Polar Unit Permanent Magnet Flux Paths.

Polar Unit

The polar unit consists of a rectangular shaped magnetic frame, an electromagnet, a permanent magnet, and an armature. The poles of the crescent shaped permanent magnet bridge the magnet frame. The magnetic frame consists of three pieces joined in the rear with two brass rods and silver solder. These non-magnetic joints represent air gaps, which are bridged by two adjustable magnetic shunts. The winding or windings are wound around a magnetic core. The armature is fastened to this core and is free to move in the front air gap. The moving contact is connected to the free end of a leaf spring, which, in turn, is fastened to the armature.

Indicating Contactor Switch

The d-c indicating contactor switch is a small clapper type device. A magnetic armature, to which leaf-spring mounted contacts are attached, is attracted to the magnetic core upon energization of the switch. When the switch closes, the moving contacts bridge two stationary contacts, completing the trip circuit. Also during this operation two fingers on the armature deflect a spring located on the front of the switch, which allows the operation indicator target to drop. The target is reset from the outside of the case by a push rod located at the bottom of the cover.

The front spring, in addition to holding the target, provides restraint for the armature and thus controls the pickup value of the switch.

OPERATION

Pilot Wire Monitoring

Monitoring current is introduced into the pilot wire as shown in the external schematics, figures 21 to 27, by the monitoring current source. External schematics showing other combinations are available on request. A nominal 20 volts is impressed across the 10 mfd. capacitor at the left-hand line terminal in Figures 21 to 27. This voltage produces a current circulating through one winding of the HCB insulating transformer, one pilot wire, the PM-23, PM-2, or PM-4, and back through the other pilot wire and the other winding of HCB insulating transformer.

Adjustment of the resistors of the PM-23, PM-2 or PM-4 relay at the other end of the pilot wire provides a normal one-milliampere d-c circulating current. In the case of three-terminal lines, the monitoring source relay output current is 2 ma. in order to pro-

vide each receiving end relay with 1 ma. The alarm unit of the monitoring current source relay is adjusted to float between the high and low current contacts with normal monitoring current. The PM-23, receiving-end alarm relay, is adjusted to float between the low-current alarm contact and a contact stop with 1 ma. flowing.

Short Circuits

A complete or partial short circuit on the pilot wires increases the current in the current-source relay, causing the high-current alarm contacts to close. The resulting current decrease in the PM-23 relay closes the alarm contact. Short circuits of 5000 ohms or less will be detected.

Open Circuits

Current decreases to zero in all relays. Low-current alarm contact of the current source relay closes. Alarm contact of PM-23 relay closes.

Reversed Wires

On applications using the PM-23 relay, current increases in the sending end relay to close the high-current alarm contacts. Current drops to zero in the PM-23 relay monitoring coil to close the low-current alarm contacts.

If the pilot wire should be opened and reclosed with reversed connections when the PM-23 relay is in service, the alarm contact (2) in the PM-23 drops out. The alarm contact dropping out shunts the trip unit coil (3), and prevents the trip unit contact (3) from operating momentarily. The trip unit contact is prevented from operating because the capacitor at the sending end discharges through the pilot wire and the trip unit (3) circuit. This will have no effect on remote trip operation.

The current decreases in both sending and receiving end relays when the PM-2, or PM-4 relays are used. Low current alarm contacts close.

The voltage-divider circuit of the PMA, PMD, and PMG-13 source relays has its midpoint grounded through a current-limiting resistor. Thus, a pilot-wire ground will cause an increase in current in one coil circuit, and a decrease in the other one. This unbalance in the current flowing through the two windings (5) of the ground alarm relay unit will cause it to close one of its contacts (depending on which pilot wire is grounded) to give an alarm. Grounds of 10,000 ohms or less will be detected.

TYPE PM MONITORING RELAYS

For adding the sensitive ground detection where PMA-1, PMD-1, or PM-13 relays have been installed, the PM-5 relay can be added to the circuitry, as shown in figure 24. This relay also has a 10,000-ohm ground sensitivity.

Transferred Tripping

Breakers located at the PMG-13 or PM-13 and PM-3 or PM-23 stations can be tripped by the application of a d-c voltage to the pilot wires at remote locations, as shown in figures 21 to 27. Transferred tripping can be effected from any location by applying 48 volts d-c (through dropping resistors when required) to the pilot wire with polarity opposite to that of the monitoring voltage. When tripping the PM-23, the current is increased above 2.0 ma, in reverse direction, to close the trip contact. When tripping the PMG-13 or PM-13, the reversed d.c. voltage operates the trip unit (3).

See Tables II and III for tripping resistor values. Nominal tripping currents is 5ma. at all rated voltages.

Polar Unit

Polar unit flux paths are shown in figure 1. With balanced air gaps, permanent magnet flux flows in two paths, one through the front, and one through the rear gaps. This flux produces north and south poles, as shown. By turning the left shunt in, some of the flux is forced through the armature, making it a north pole. Thus, reducing the left hand rear gap will produce a force tending to pull the armature to the right. Similarly, reducing the right hand gap will make the armature a south pole and produce a force tending to pull the armature to the left.

The alarm unit contacts of the sending and receiving end relays are biased to move to the left when the relay is deenergized. The PMG-13 or PM-13 and PM-23 trip unit contact is biased to move to the left when the relay is deenergized. The PM-5 is adjusted so that the moving contact floats when the relay is deenergized.

CHARACTERISTICS

Nominal Calibration Values

Nominal current values to close contacts are listed in Tables IV and V.

Voltage Ratings

Supply voltage ratings of the monitoring source

relays to obtain continuous monitoring current are as follows:

DC - 48, 125, and 250 volts

AC - 120 volts, 60 cycles (Primary taps 100, 110, 120 & 130)

Voltage impressed on the pilot wire is a nominal 20 volts for monitoring, and 48 volts for tripping.

Supply voltage ratings to obtain remote tripping are: 48, 125, and 250 volts d-c.

Coil Resistance (each winding)

Alarm coil (1)	
two terminal line	1050-1250 ohms
three terminal line	700-900 ohms
Alarm coil (2)	2200-2600 ohms
Trip coil (3)	1800-2200 ohms
Ground Alarm coil (5)	5200-5800 ohms

PM-4 and PM-23 Resistance

Nominal PM-4 and PM-23 total resistance when adjusted for service is 20,000 ohms less pilot wire loop resistance at 1 ma.

PMA, PMA-1 and AC PMG-13, PM-13 Burden

0.5 VA at tap voltage	-	2-terminal line relay
1.0 VA at tap voltage	--	3-terminal line relay

Rectifiers

Approximate forward resistance- 560 ohms at 1 ma
300 ohms at 2 ma

Rating

Continuous forward
current - amperes - 1

Continuous back
voltage-rms volts - 200

Remote Tripping

Remote trip resistors are listed in Table II and III for 48, 125, and 250 volts d-c.

The relays have sufficient thermal capacity to withstand 20 MA d-c continuously when remote tripping. Nominal trip currents in the tripping relays are 5.0 MA d-c with 48, 125, and 250 volts d-c supply and a 2000-ohm pilot wire.

TABLE II

PMA, PMA-1, PMD, AND PMD-1 APPLICATIONS
EXTERNAL RESISTORS FOR D.C. REMOTE TRIPPING
(2 REQUIRED PER STATION)

# LINE TERMINALS	D.C. VOLTAGE	STATION A PMA or PMA-1	STATION A PMD or PMD-1	STATION B PM-2 & PM-3 or PM-23 or PM-4	STATION C PM-2 & PM-3 or PM-23 or PM-4	TO OPERATE
2	48	200	200	—	—	PM-23 or PM-3
	125	3550	3550	—	—	"
	250	9300	9300	—	—	"
3	48	200	200	—	—	"
	125	2000	2000	—	—	"
	250	5600	5600	—	—	"

TABLE IIIA

PMG-13 AND PM-13 (D.C. SUPPLY) APPLICATIONS
RESISTORS FOR D.C. REMOTE TRIPPING
(2 REQUIRED PER STATION)

# LINE TERMINALS	D.C. VOLTAGE	STATION A PMG-13 or PM-13	STATION B PM-2 & PM-3 or PM-23 or PM-4	STATION C PM-2 & PM-3 or PM-23 or PM-4	TO OPERATE
2	48	200 †	200	—	PMG-13 or PM-13 and PM-23 or PM-3
	125	2120 †	2120	—	"
	250	5600 †	5600	—	"
3	48	200 †	200	200	"
	125	1500 †	1500	1500	"
	250	4000 †	4000	4000	"

† Mounted in Relay

TABLE IIIB

PMG-13 AND PM-13 (A.C. SUPPLY) APPLICATIONS
(2 REQUIRED PER STATION)
RESISTORS FOR D.C. REMOTE TRIPPING

# LINE TERMINALS	D.C. VOLTAGE	STATION A PMG-13 or PM-13	STATION B PM-2 & PM-3 or PM-23 or PM-4	STATION C PM-2 & PM-3 or PM-23 or PM-4	TO OPERATE
2	48	200 †	200	—	PMG-13 or PM-13 and PM-23 or PM-3
	125	2120 †	2120	—	"
	250	5600 †	5600	—	"
3	48	200 †	200	200	"
	125	1500 †	1500	1500	"
	250	4000 †	4000	4000	"

† Mounted in Relay

TABLE IV

NOMINAL CALIBRATION VALUES – TWO TERMINAL LINES

<u>RELAY</u>	<u>LOW CURRENT ALARM</u> ¹	<u>HIGH CURRENT ALARM</u> ²	<u>TRIP</u>
PMA or PMA-1	0.7 ma	1.3 ma	—
PMD or PMD-1	0.7	1.3	—
PM-5 †	—	±0.3	—
PMG-13 or PM-13	0.7 ††	1.3 ††	14 V.
PM-23 or PM-2 & PM-3 †	0.7	—	14 V.

† Same relay as for three-terminal lines

†† These are pilot-wire current values

1—Left-hand contacts, front view.

2—Right-hand contacts, front view.

TABLE V

NOMINAL CALIBRATION VALUES – THREE TERMINAL LINES

<u>RELAY</u>	<u>LOW CURRENT ALARM</u>	<u>HIGH CURRENT ALARM</u>	<u>TRIP</u>
PMA or PMA-1 •	1.7 ma	2.3 ma	—
PMD or PMD-1	1.7	2.3	—
PM-5 †	—	±0.3	—
PMG-13 or PM-13	1.7 ††	2.3 ††	14 V.
PM-23 or PM-2 & PM-3 †	0.7	—	14 V.

† Same relay as for two-terminal lines

†† These are pilot-wire current values

Trip Circuit

The main contacts will safely close 30 amperes at 250 volts d-c and the seal-in contacts of the indicating contactor switch will safely carry this current long enough to trip a circuit breaker.

The indicating contactor switch has two taps that provide a pickup setting of 0.2 or 2 amperes. To change taps requires connecting the lead located in front of the tap block to the desired setting by means of a screw connection.

Trip Circuit Constant

Indicating Contactor Switch (ICS)

0.2 ampere tap 6.5 ohms d-c resistance

2.0 ampere tap 0.15 ohms d-c resistance

SETTING THE RELAY

Operating units of all relays are adjusted in the factory to the values listed in Tables IV and V to a tolerance of ±5%. No settings are required on these units.

For all 48/125-volt d.c. relays, connect jumpers across resistors as shown on the internal schematics.

PM-4, PM-2, and PM-23 Relays

Adjust the resistors in the PM-4, PM-2, or PM-23 relay or relays to a value of 1 MA d-c with the monitoring circuits connected for service. Use the milliammeter in the PM-23 for this purpose or use a portable milliammeter with a resistance of less than 200 ohms. Where it is not practical on three-terminal lines to adjust both receiving relays simultaneously, set one receiving relay for 18,000 ohms total resistance (including relay coil and resistors) by measurement prior to final adjustment of the other receiving relay. This procedure will minimize the change in monitoring current in the first relay to be adjusted when making the final adjustment of the second relay.

PMA, PMA-1, PMG-13 and PM-13 Relays

Select the transformer tap nearest to expected normal a-c supply voltage. The full wave rectifier is

connected to a secondary transformer tap. Where desired, the output voltage can be raised about 5% by reconnecting across the full secondary winding.

Indicating Contactor Switch

No setting is required on the ICS unit except the selection of the 0.2 or 2.0 ampere tap setting. This selection is made by connecting the lead located in front of the tap block to the desired setting by means of the connecting screw. When the relay energizes a type WL relay switch, or equivalent, use the 0.2 ampere tap.

INSTALLATION

The relays should be mounted on switchboard panels or their equivalent in a location free from dirt, moisture, excessive vibration, and heat. Mount the relay vertically by means of the four mounting holes on the flange for semi-flush mounting or by means of the rear mounting stud or studs for projection mounting. Either a mounting stud or the mounting screws may be utilized for grounding the relay. The electrical connections may be made directly to the terminals by means of screws for steel panel mounting or to the terminal studs furnished with the relay for thick panel mounting. The terminal studs may be easily removed or inserted by locking two nuts on the stud and then turning the proper nut with a wrench.

For detailed FT case information, refer to I.L. 41-076.

Where the potential to ground impressed on the relays can exceed 700 volts, a drainage reactor in conjunction with a KX-642 tube, or the reactor in conjunction with 700 volt carbon-block arresters, is recommended. For details, see Protection of Pilot-Wire Circuits, AIEE Committee Report, paper 58-1190, AIEE Transactions, 1959, Volume 78, Part III B pp. 205-212. Also, see AIEE Special Publication S-117, Applications and Protection of Pilot-Wire Circuits for Protective Relaying, July 1960.

ADJUSTMENTS AND MAINTENANCE

The proper adjustments to insure correct operation of this relay have been made at the factory and should not be disturbed after receipt by the customer. If the adjustments have been changed, the relay taken apart for repairs, or if it is desired to check the adjustments at regular maintenance periods, the instructions in the succeeding sections should be followed.

Acceptance Tests

The following tests are recommended when the relay is received from the factory. If the relay does not perform as specified below, the relay either is not properly calibrated or it contains a defect.

Indicating Contactor Switch (ICS)

Close the contact of the tripping unit and pass sufficient direct current through the trip circuit to close the contacts of the ICS unit. This value of current should not be greater than the particular ICS tap setting being used (0.2 or 2.0). The indicator target should drop freely.

PMA and PMA-1 Relays

Alarm Unit (1)

Set the primary tap on 120 volts. Connect a variable resistor of approximately 20,000 ohms in series with a low-range d-c milliammeter across terminals 6 and 7 with the instrument positive connected to terminal 7. Apply 120 volts at rated frequency to terminals 4 and 5. Adjust the 20,000-ohm resistor to obtain a current of one ma. d.c. For a three-terminal line relay, use a 10,000-ohm resistor and set the current to 2 ma. d.c. At this value, the moving contact of the alarm or monitoring relay unit (1) should float between the two sets of stationary contacts. In the PMA relay, the ground alarm unit (5) contact should also float. (This contact will also float when the relay is de-energized.) Increase and decrease the one or two-milliampere monitoring current to check the calibration values listed in Tables IV and V.

Ground Unit (5)

Reconnect the 20,000-ohm resistor. For the PMA relay only, short terminals 7 and 3. The contact of the ground alarm unit (5) should close to the right when the relay is energized. Remove the short, and connect it between terminals 6 and 3. The ground alarm unit (5) should close to the left. The action of the monitoring unit (1) contact is of no significance in this simulated pilot-wire ground test. To check the pickup current of the ground detector, first remove the 20,000-ohm resistor from terminals 6 and 7. Connect a 0-1 d.c. milliammeter in series with a variable resistor of about 50,000 ohms between terminals 3 and 6. The ground unit should close its left-hand contact at approximately 0.3 ma. d.c. With the milliammeter and resistor connected between terminals 3 and 7, the right-hand contact should close at 0.3 ma. d.c.

TYPE PM MONITORING RELAYS

PMD and PMD-1 Relays

Alarm and Ground Units

Connect an adjustable 20,000-ohm resistor (or 10,000-ohms for a 3-terminal relay) in series with a d-c milliammeter across terminals 6 and 7 with the instrument positive connected to terminal 7. Apply rated d-c voltage to terminals 8 and 9 with positive on terminal 9. Now check the PMD and PMD-1 relays, following the procedure given in the previous section for the PMA and PMA-1 relays, respectively. Note, however, that terminal 5 of the PMD relay corresponds to terminal 3 of the PMA relay.

PM-2, PM-3, and PM-23 Relays

Alarm Unit (2)

Apply a variable d-c voltage of approximately 20 volts to relay terminals 8 and 9 (terminal 9 positive) of the PM-2 or PM-23 relay. Adjust the voltage to obtain a reading of one ma. on the relay milliammeter. The monitoring polar unit (2) contacts should float. Reduce the current gradually. The monitoring alarm contacts should close at 0.7 ma. d.c. The tripping unit (3) of the PM-23 relay should not move during this test. The milliammeter has been adjusted to read 1 ma. $\pm 5\%$. As a result the pointer may not read zero for a zero current condition.

Tripping Unit (3)

To check the PM-3 relay or the tripping unit of the PM-23 relay, apply the variable d-c voltage in series with an external milliammeter to relay terminals 8 and 9 with terminal 8 positive for the PM-23 relay, or terminal 9 positive for the PM-3 relay. When checking the pickup of the PM-23 trip unit contacts (2) so as to remove the shunt resistor from around the trip coil (3).

The tripping relay unit (3) should pick up with positive action at 14 volts d.c. and should drop out at approximately 10 volts. The alarm unit of the PM-23 relay will not operate during this test.

PM-4 Relay

This device is simply a set of resistors and a diode to connect into the pilot-wire circuit to provide a path for the monitoring current. The resistors can be checked with an ohmmeter, and the diode can be checked either with an ohmmeter, or as explained in the section entitled "Rectifier Check" under "Routine Maintenance". If an ohmmeter is used, the difference in forward and reverse resistance readings obtained will be dependent on the current flowing through the diode.

PM-5 Relay

Apply 5 volts d.c. in series with a 0-1 d.c. milliammeter and a 20,000-ohm variable resistor to terminals 6 and 7 with positive on terminal 6. The left-hand contact should close at approximately 0.3 ma. Now apply the same circuit to terminals 8 and 9 with positive on terminal 9. The right-hand contact should close at approximately 0.3 ma.

PM 13 Relays - A.C. and D.C.

Alarm Unit (1)

Connect a variable 20,000-ohm resistor (10,000 ohms for a 3-terminal-line relay) in series with a d-c milliammeter across terminals 8 and 9 with the instrument positive on terminal 9. For the a-c relay, set the primary tap on 120 volts. Now apply the rated supply voltage to terminals 4 and 5. This will be 48, 125, or 250 volts d.c., or 120 volts a.c. as indicated on the relay nameplate. Adjust the variable resistor to obtain a current of one ma. for a 2-terminal line relay, or 2 ma. for a 3-terminal relay. At this value, the moving contacts of the alarm or monitoring (1) relay unit (the upper polar unit) should float between the two sets of stationary contacts. Increase and decrease the one or 2 ma. monitoring current to check the calibration values listed in Tables IV and V.

Tripping Unit (3)

To check the operation of the tripping unit 3 (the lower polar unit), apply a d.c. potential across terminals 16 (positive) and 20 (negative). The tripping polar unit should pick up at 14 volts, and should drop out at approximately 10 volts. The resistance of the series dropping resistors for transferred tripping (listed in Tables III A and III B) can be checked with an ohmmeter. The circuit location of these resistors can readily be seen from the external schematic, Figure 27.

PMG-13 Relays - A.C. and D.C.

Alarm and Tripping Units

Follow the procedure given in the previous section for the a-c. and d-c. PM-13 relays.

Ground Unit (5)

Connect the 20,000-ohm (or 10,000-ohm) resistor and milliammeter across terminals 8 and 9. With rated voltage applied and one ma. (or 2 ma.) flowing, successively short circuit terminals 3 and 8, then 3 and 9. The ground alarm unit 5 (lower polar unit) should move first to the left, then to the right. To check the pickup current of the ground detector, first remove the 20,000-ohm resistor from terminals 8 and 9. Connect a 0-1 d.c. milliammeter in series with a variable

resistor of about 50,000 ohms between terminals 3 and 8. The left-hand contact should close at approximately 0.3 ma. d.c. With the milliammeter resistor connected, between terminals 3 and 9, the right-hand contact should close at 3.0 ma. d.c. The external schematic diagrams for these relays are shown in Figure 23 and 25.

Routine Maintenance

CAUTION - Do not make any performance check, calibration tests, or adjustments while the PM relays are energized or connected to the pilot wires, to prevent the possibility of inadvertently causing a break operation. The PM relays may be removed from service for testing, without jeopardizing HCB relay protection, providing that the connections between the 10-mfd capacitor and the HCB insulating transformer are not disturbed.

Contacts

All contacts should be periodically cleaned. A contact burnisher S#182A836H01 is recommended for this purpose. The use of abrasive material for cleaning contacts is not recommended because of the danger of embedding small particles in the face of the soft silver and thus impairing the contact.

Operational Check

In addition to cleaning contacts, it is recommended that an operational check be performed periodically by opening and short-circuiting the pilot wires, as well as grounding them at the relay terminals. **Note:** These pilot-wire faults should not be applied directly to the pilot wires when the HCB relays are in service. It is also recommended that the trip circuits of the PM relays be opened (where tripping is used), to prevent the possibility of inadvertently tripping the associated circuit breaker during testing. If the relays do not perform as expected, and diode failure is suspected, the diode tests described in the following section may be performed.

Rectifier (Diode) Check

If there is suspicion of a rectifier (diode) failure, apply 30 volts d.c. reverse voltage (positive on arrow-head) through a 300-ohm resistance to the diode. Measure the voltage across the diode. If this voltage is not essentially 30 volts, the diode is short-circuited. Now apply 30 volts d.c. in the forward direction through the 300-ohm resistor, and measure the voltage across the resistor. If the voltage is not essentially 30 volts, the diode may have a high forward resistance. If the voltage is zero, the diode is open-circuited.

Calibration

If the relay has been dismantled or the calibration has been disturbed, use the following procedure for calibration.

With the permanent magnet removed, see that the moving armature floats in the central area of the air-gap between the poles of the polar unit frame. If necessary, loosen the core screw in the center rear of the unit and shift the core and contact assembly until the armature floats. (This can best be done with the polar unit removed from the relay.) Then retighten the core screw and replace the permanent magnet with the dimple (north pole) on the magnet to the left when viewed from the front.

Polar Units-General

The following mechanical adjustments are given as a guide, and some deviation from them may be necessary to obtain proper electrical calibration.

Magnetic Shunt Adjustment

The sensitivity of the polar unit is adjusted by means of two magnetic, screw-type shunts at the rear of the unit, as shown in Fig. 1. These shunt screws are held in proper adjustment by a flat strip spring across the back of the polar unit frame, so no locking screws are required. Looking at the relay, front view turning out the right-hand shunt to open the right-hand air gap decreases the amount of current required to close the right-hand contact. Conversely, drawing out the left-hand shunt increases the amount of current required to close the right-hand contact, or decreases the amount of current required to close the left-hand contact (with the proper direction of current flow). Also, if a relay trips to the right at the proper current, the dropout current can be raised by turning in the right-hand shunt. The two shunt-screw adjustments are not independent, however, and a certain amount of trimming adjustment of both shunt screws is generally necessary to obtain the desired pickup and dropout calibration.

In general, the farther out the two shunt screws are turned, the greater the toggle action will be, and as a result, the lower the dropout current. For the tripping units (3) of the PM-3, PM-13, and PM-23 relays, toggle action is desirable, with a dropout current around 75 percent of the pickup current. For the monitoring alarm relay units, toggle action is not desired. Instead, the armature is adjusted to float between the pole faces at a given current (1 or 2

TYPE PM MONITORING RELAYS

The following chart indicates the units present in each relay.

FUNCTION AND UNIT	PMA PMD	PMA-1 PMD-1	PM2	PM3	PM4	PM5	PM13	PMG13	PM23
Alarm for p.w. open, short or reversal (1) (2)	X	X	X				X	X	X
Transfer - Trip Unit (3)				X			X	X	X
Alarm for p.w. ground (5)	X					X		X	
D.C. Path for Monitoring Current					X				

ma.), and to move gradually toward the high or low-current alarm as the coil current is increased or decreased. Similarly, the floating adjustment of the armature of the ground alarm unit (5) requires that both shunt screws be turned in relatively far. Then the armature will move gradually to the left or right as the current through the two #5 coils is unbalanced.

The electrical calibration of the polar unit is also affected by the contact adjustment as this changes the position of the polar unit armature. Do not change the contact adjustment without rechecking the electrical calibration.

Contact Adjustment - All Relays

For all monitoring alarm units, designated (1) or (2), turn in all the stationary contact and contact stop screws until they just touch the moving contact. Advance the screws to hold the armature in the central portion of the magnetic air gap between the two pole faces. (The stationary contact screws have a round silver contact face; the stop screws do not have this silver facing.) Now back off all the contact and contact stop screws one full turn. This will give a total contact travel of 0.050 inch. When the relay is properly calibrated, some touch-up adjustment may be necessary so that double contacts will both close at the same current value. The contact gap between the floating moving contact and the right-hand or left-hand stationary contacts or contact stops will be approximately 0.025 inch when the relay is in operation.

For the tripping (3) units of the PM-3, PM-13, PMG-13, and PM-23 relays, adjust the contacts as described in the previous paragraph, except back off the contact and stop screws one-half turn each to

give a total moving contact travel of approximately 0.025 inch. In operation of the tripping unit, the moving contact will normally rest against the contact stop screws, and will pick up only for a transferred-tripping operation.

For the pilot-wire ground alarm unit (5) of the PMA, PMD, PM5, and PMG-13 relays, follow the same general procedure except back off both stationary contact screws two turns each. This will give a contact gap of 0.050 on each side of the moving contact when it is its normal central position.

Electrical Calibration - All Relays

In the following sections, the calibration instructions are given for the polar unit which performs a certain function, such as alarm (1) or (2), ground (5), or trip (3), rather than giving calibration instructions for each complete relay. In this way, considerable duplication of instructions has been eliminated.

Alarm Unit (1)

Connect the relay as described under Acceptance Tests for the particular relay involved. Screw the two magnetic shunts all the way in, then back them out five turns each. With the relay energized at rated voltage, set the monitoring current at 1.3 or 2.3 ma. d.c. for 2 or 3-terminal relay respectively, by adjusting the external resistor. If the relay does not close its right-hand contact, turn in the left shunt screw until the right-hand contact just closes. If the right-hand contact is closed at 1.3 ma., turn in the right shunt until a point is reached when the right-hand contact is just closed at 1.3 ma.

Now drop the current to 0.7 ma. and adjust the opposite shunt until the left-hand contact just closes

at 0.7 ma. d.c. At 1.0 ma. d.c., the moving contact should float half way between the two sets of stationary contacts with a 0.025-inch gap on each side. Recheck the high and low current calibration several times, touching up the shunt adjustments as required to obtain the desired calibration.

Polarization Check

For all the source relays, which are listed below, make the following additional calibration check:

- PMA PM-13 (a.c. and d.c.)
- PMA-1 PMG-13 (a.c. and d.c.)
- PMD
- PMD-1

After calibration as described in the previous sections, connect a 20,000 ohm resistor (or 10,000 ohms for 3-terminal applications) across the output terminals, and energize the relay at its rated supply voltage. With these connections, approximately one (or two) milliamperes d.c. will flow through the monitor relay coils and external resistor, thus representing normal operating conditions.

Now momentarily (one second or so) apply 48 volts d.c. directly to the pilot-wire terminals of the relay, as indicated in the following table.

Relay	Terminals for Momentary Application of 48 V. d.c.	
	POS.	NEG.
PMA, PMA-1 } PMD, PMD-1 }	6	7
PM-13 (a.c. or d.c.) } PMG-13 (a.c. or d.c.) }	8	9

After momentary application of the transfer-trip voltage as just explained, recheck the calibration of the monitoring alarm unit (1). If it has changed, make necessary trimming adjustments of the shunt screws until there is no change in calibrating of the alarm unit (1) after the transfer-trip voltage has been applied. The purpose of this test is to compensate for the small residual magnetism in the relay unit. The ground alarm unit (5) will not be affected by this test as the ampere-turns of the two windings cancel each other.

Alarm Unit (2)

For the alarm unit of the PM-2 or PM-23 relays, adjust the shunts so that the relay moving contact

floats at one ma. d.c., and closes the left-hand contact at 0.7 ma. d.c. The moving contact should float midway between the contact and contact stop at 1.0 ma. d.c. There is no high-current calibration for this relay unit.

Now apply 48 volts d.c. momentarily (one second or so) across the alarm unit coil-circuit terminals in a direction to operate the alarm relay. Then recheck the alarm unit calibration. If there is any change, touch up the shunt adjustments until there is no change in calibration after 48 v. d.c. has been applied.

Tripping Unit (3)

To calibrate the tripping unit of the PM-3, PM-13, PMG-13, or PM-23 relays apply a d.c. voltage as explained below, to the following relay terminals:

Relays	D.C.	Voltage
	Pos.	Neg.
PM-3	9	8
PM-13 (a.c. or d.c.)	16	20
PMG-13 (a.c. or d.c.)	8	9
PM-23	8	9

Momentarily (one second or so) apply 48 volts d.c. to the terminals shown in the chart. Then starting with both shunts all the way in, turn out the right-hand shunt screw until the relay closes its right-hand trip contact at 14 volts d.c. (This will give approximately 2 ma. through the relay coil.) Now draw out the left-hand shunt until the relay resets with toggle action (not gradually) at not less than 10 volts d.c. When the calibration is approximately correct, again apply 48 volts d.c. to the indicated terminals, then recheck the pickup and dropout voltage, making any necessary trimming adjustments of the shunts. When the relay is properly adjusted, the application of 48 volts.d.c. will not change the pickup or dropout voltage points. The relay should trip and reset with toggle action in this application. This will require both shunt screws to be withdrawn farther than for floating action.

Ground Alarm Unit (5)

For the PM-5 relay, turn both shunt screws all the way in, then back them out five turns each. Pass a current of 0.3 ma. d.c. in terminal 6 and out terminal 7. Following the same general procedure as described previously in the section entitled "Alarm Unit (1)," adjust the shunt screws so that the left-hand contact closes at 0.3 ma. Now pass 0.3 ma. d.c.

TYPE PM MONITORING RELAYS

in terminal 9 and out terminal 8, and adjust for closing of the right-hand contact at 0.3 ma. Recheck both pickup points several times, and make trimming adjustments of both shunts as required to obtain contact closing at 0.3 ma. d.c. in each direction.

For the ground unit (5) of the PMA, PMD, and PMG-13 relays, connect a variable resistance of about 50,000 ohms in series with a 0-1 d.c. milliammeter between the terminals indicated in the following table:

Turn the shunts all the way in, then back them out five turns each. With the relay connected as shown in the left-hand column of the table, apply rated voltage to the relay and adjust the 50,000-ohm resistor for 0.3 ma. d.c. Now following the procedure in the previous paragraph for the PM-5 relay, adjust the shunts until the left-hand contact closes at 0.3 ma. d.c. Change the connections as indicated in the right-hand column, and adjust the opposite shunt until the right-hand contact closes. Recheck back and forth several times and make necessary trimming adjustments to obtain pickup at 0.3 ma. In each direction. The armature will move gradually as the

current is changed for this relay unit.

ICS Unit

Close the main relay tripping contact circuit with a jumper connected directly across the contact terminals of the polar unit. Pass sufficient direct current through the relay trip circuit to close the contacts of the ICS unit. This value of current should not be greater than the ICS tap setting being used (0.2 or 2.0). The indicator target should drop freely. The contact gap should be approximately 0.047 inch between the bridging moving contact and the adjustable stationary contacts. The bridging moving contact should touch both stationary contacts simultaneously.

RENEWAL PARTS

Repair work can be done most satisfactorily at the factory. However, interchangeable parts can be furnished to the customers who are equipped for doing repair work. When ordering parts, always give the complete nameplate data.

Ground Alarm (5) Calibration		
Relay	Relay Terminals	
	L.H. Contact Check	R.H. Contact Check
PMA	3 ⁺ and 6	3 and 7 ⁺
PMD	5 ⁺ and 6	5 and 7 ⁺
PMG-13	3 ⁺ and 8	3 and 9 ⁺

+ Milliammeter positive to this terminal

INDEX TO FIGURES

INTERNAL SCHEMATICS

FIG. NO.		PAGE NO.
1	Polar Unit Permanent Magnet Flux Paths	2
2	PMA Relay - AC supply - two terminal line	14
3	PMA-1 Relay - AC supply - two terminal line	14
4	PMA Relay - AC supply - three terminal line	14
5	PMA-1 Relay - AC supply - three terminal line	14
6	PMD Relay - DC supply - two terminal line	15
7	PMD-1 Relay - DC supply - two terminal line	15
8	PMD Relay - DC supply - three terminal line	15
9	PMD-1 Relay - DC supply - three terminal line	15
10	PM-2 relay in FT21 case	16
11	PM-3 relay in FT11 case	16
12	PM-4 relay (auxiliary unit)	16
13	PM-5 ground detector relay	16
14	PM-23 relay in FT21 case	17
15	PM-13 Relay - DC supply - two terminal line	17
16	PM-13 Relay - DC supply - three terminal line	17
17	PM-13 Relay - AC supply - two or three terminal line	17
18	PMG-13 Relay - DC supply - two terminal line	18
19	PMG-13 Relay - DC supply - three terminal line	18
20	PMG-13 Relay - AC supply - two or three terminal line	18

EXTERNAL SCHEMATICS

21	PMD relay with PM-23 or PM-4, two terminal line	19
22	PMA relay with PM-23 or PM-4, two terminal line	19
23	DC type PMG-13 with PM-23 or PM-4, two terminal line	20
24	PMD relay with PM-23 & PM-4, three terminal line	20
25	AC type PMG-13 relay with PM-23, two terminal line	21
26	DC type PM-13 & PM-5 with PM-23 or PM-4, two terminal line	21
27	DC type PM-13 relay with PM-23 or PM-4, two terminal line	22

OUTLINE & DRILLING PLANS

28	10 mfd. capacitor	23
29	Remote trip resistor	23
30	PM-4 projection molded case	23
31	PM-4 semi-flush molded case	23
32	PM-3, PM-5, & PMD-1 in FT11 case	24
33	PM-2, PM-23, PMA-1, & PMD in FT21 case	25
34	PMA in FT31 case	26
35	PM-13 and PMG-13 in FT32 case	27

TYPE PM MONITORING RELAYS

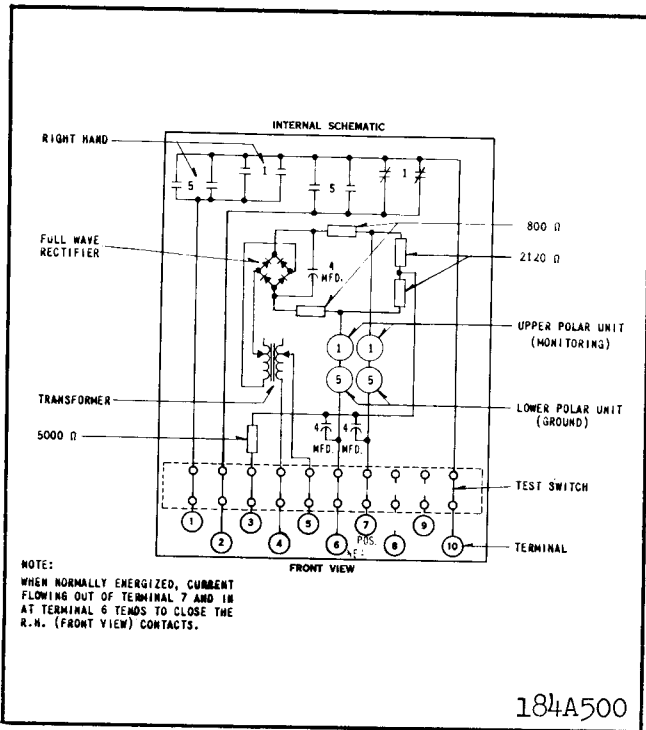

Fig. 2. Internal schematic of the type PMA relay in FT 31 case - 120 volt, 60 cycle supply - For two terminal lines.

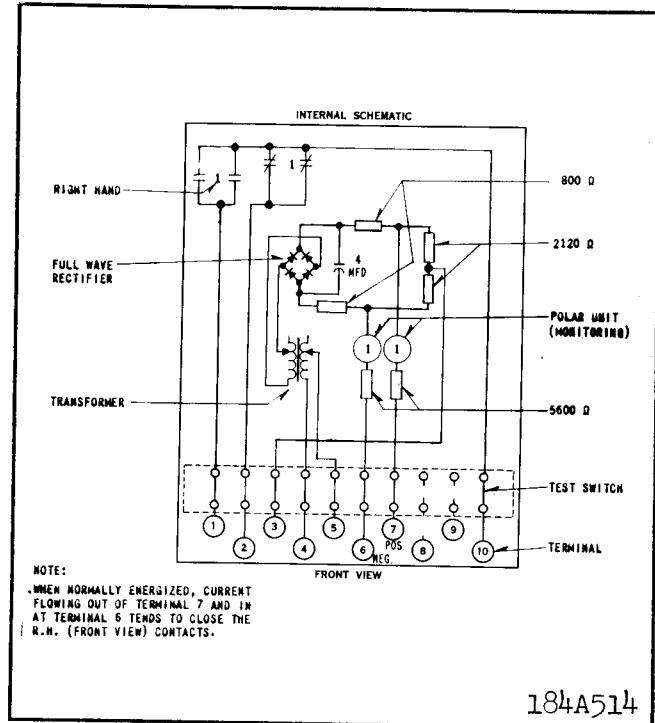

Fig. 3. Internal schematic of type PMA-1 relay in the FT 21 case - 120 volts, 60 cycle supply - For two terminal lines.

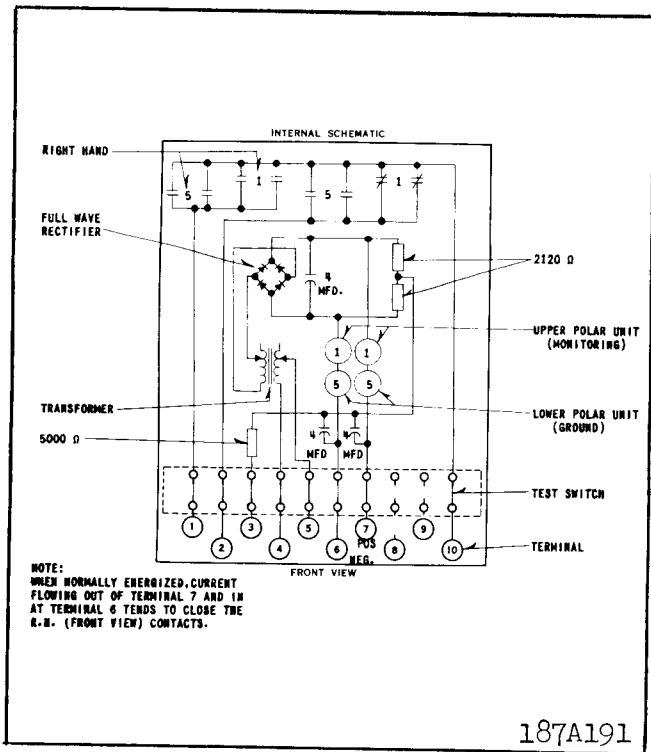

Fig. 4. Internal schematic of type PMA relay in FT 31 case - 120 volt, 60 cycle supply - For three terminal lines.

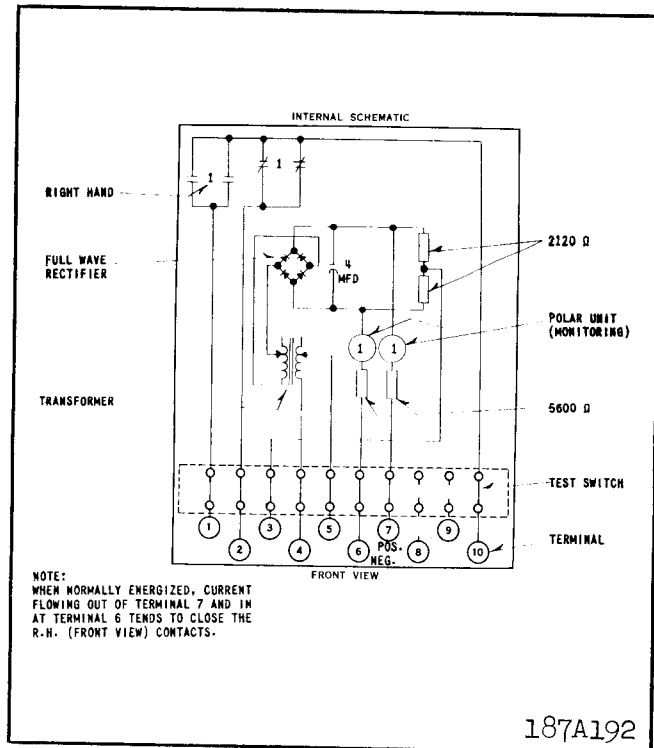

Fig. 5. Internal schematic of type PMA-1 relay in FT 21 case - 120 volt, 60 cycle supply - For three terminal lines.

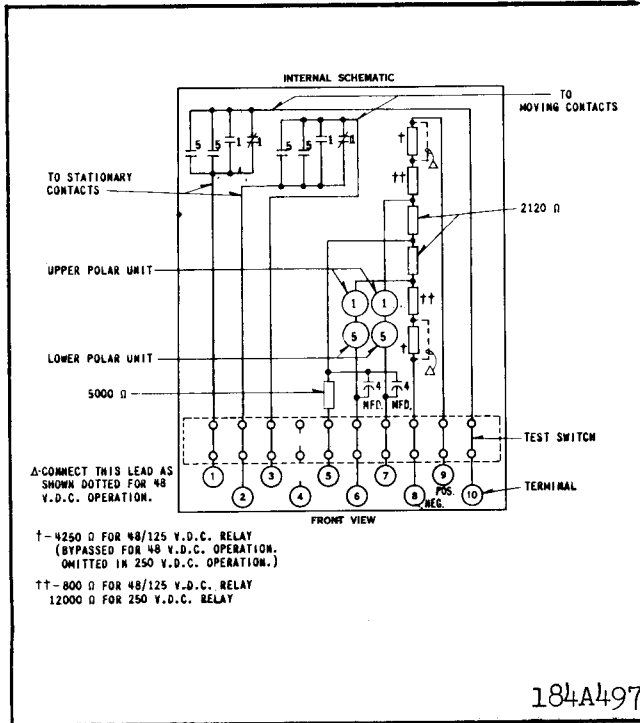

Fig. 6. Internal schematic of the type PMD relay in FT 21 case - DC supply - for two terminal lines.

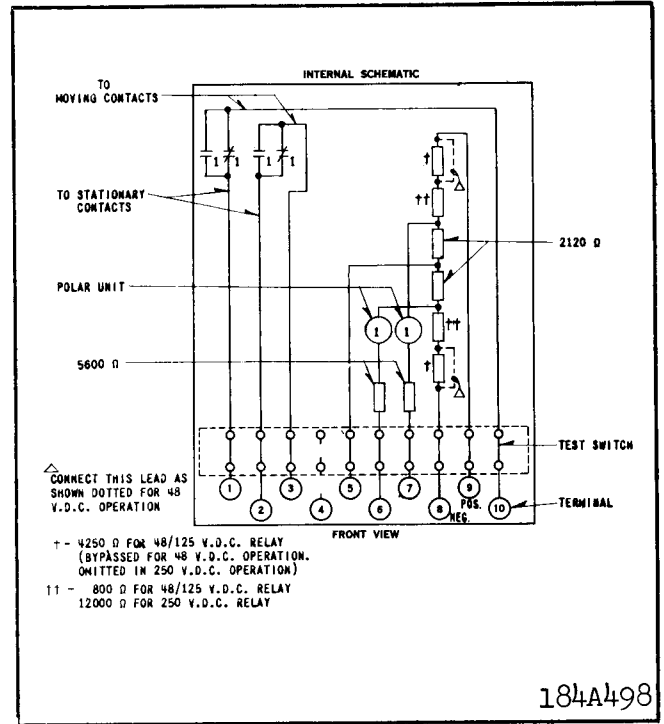

Fig. 7. Internal schematic of the type PMD-1 relay in the FT 11 case - DC supply - For two terminal lines.

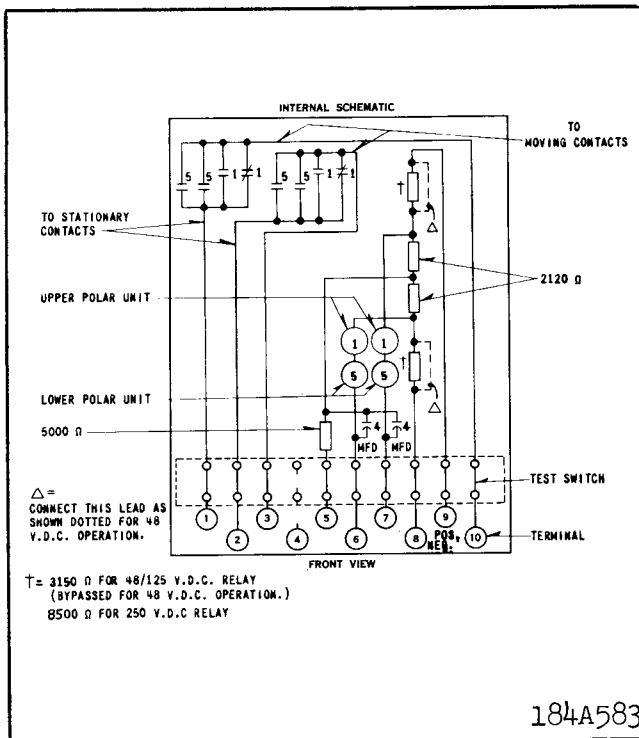

Fig. 8. Internal schematic of the type PMD relay in the FT 21 case - DC supply - For three terminal lines.

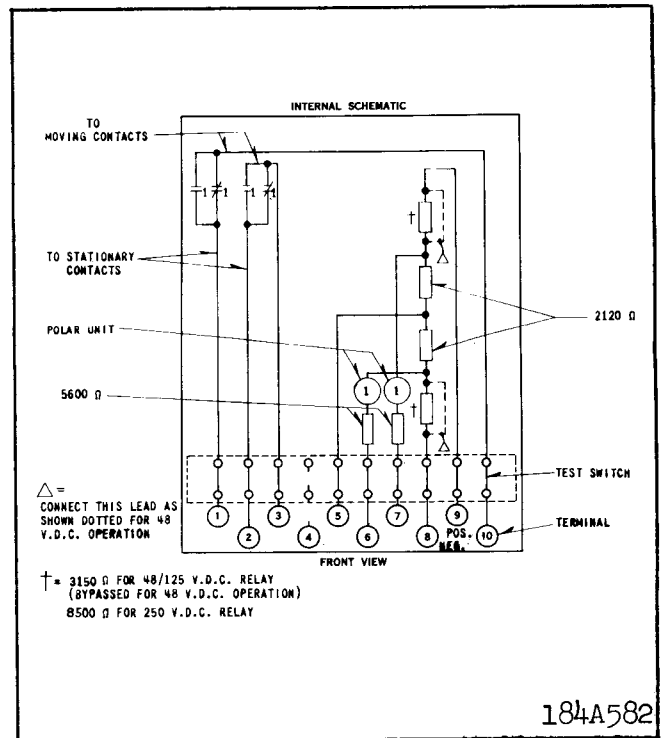

Fig. 9. Internal schematic of the type PMD-1 relay in the FT 11 case - DC supply - For three terminal lines.

TYPE PM MONITORING RELAYS

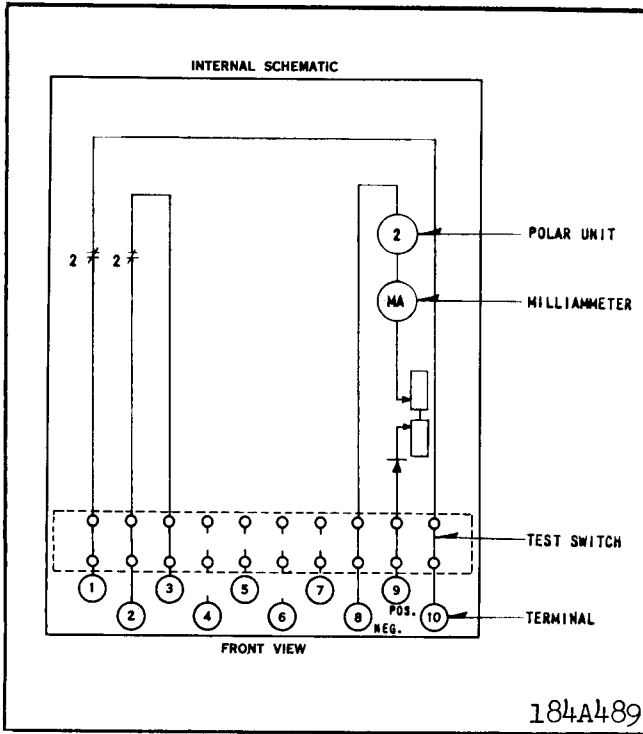

Fig. 10. Internal schematic of the type PM-2 relay in the FT 21 case.

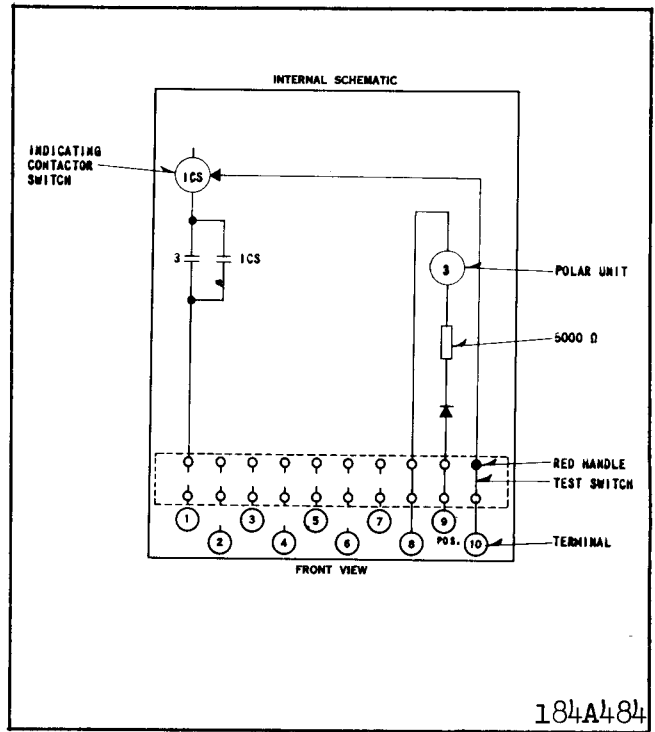

Fig. 11. Internal schematic of the type PM-3 relay in the FT 11 case.

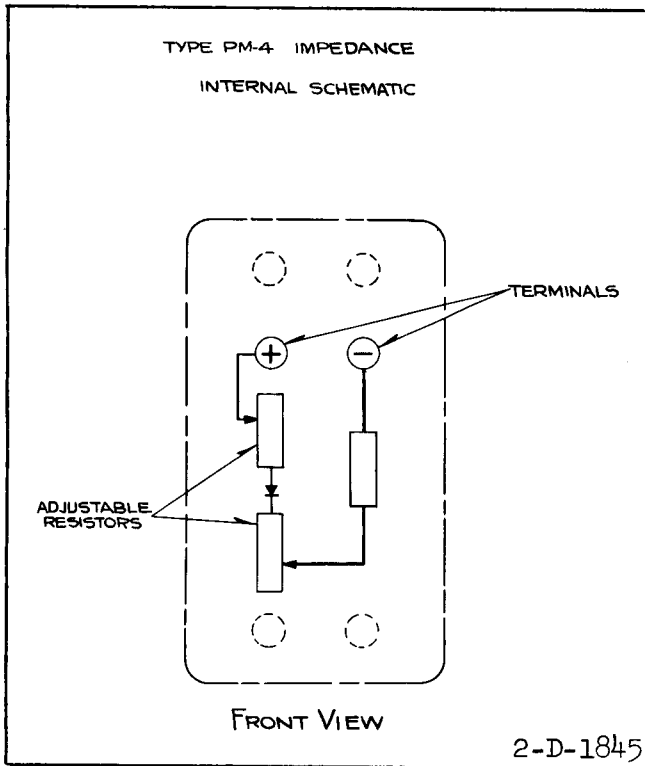

Fig. 12. Internal schematic of the type PM-4 Auxiliary Unit in the small molded case.

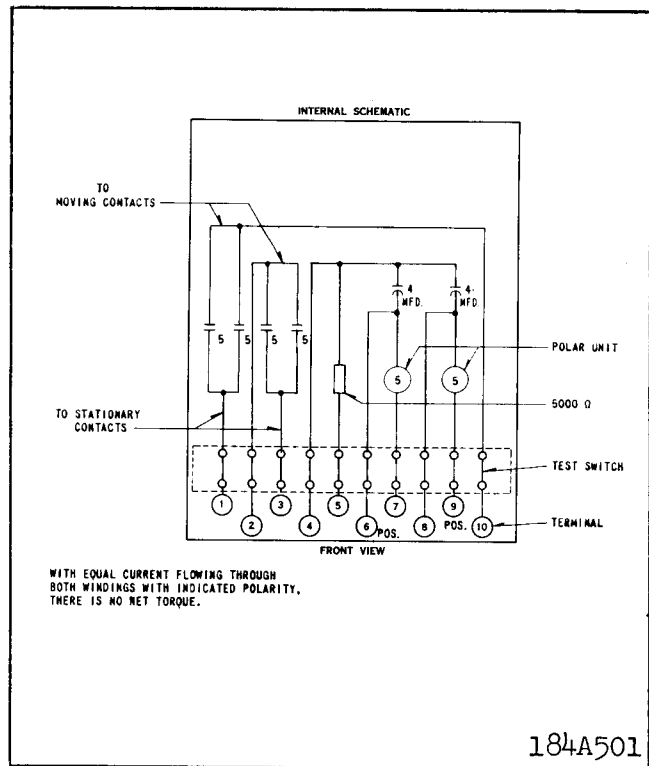

Fig. 13. Internal schematic of the type PM-5 ground detector relay in the FT 11 case.

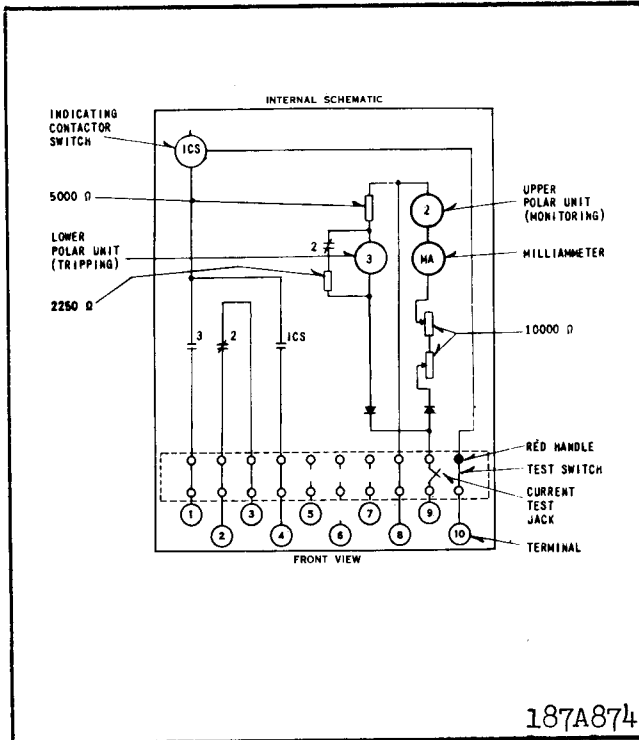

Fig. 14. Internal schematic of the type PM-23 relay in the FT 21 case.

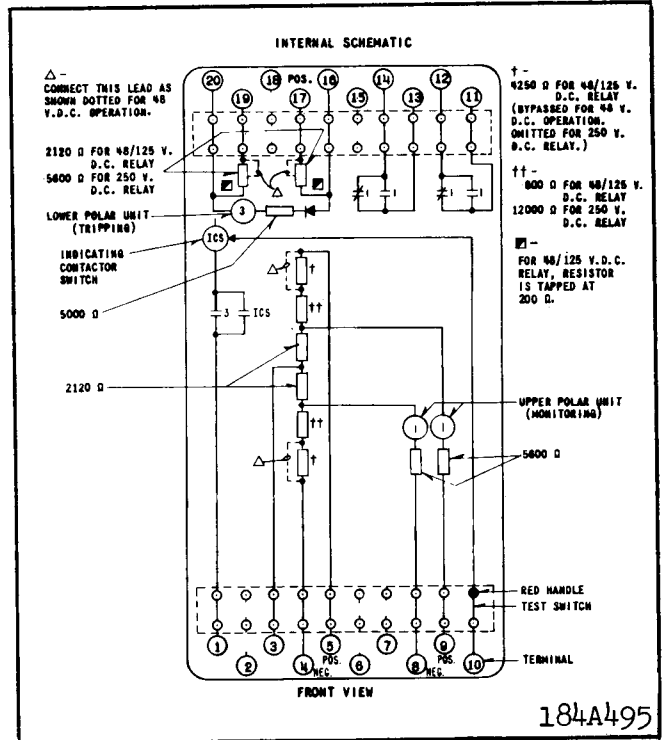

Fig. 15. Internal schematic of the type PM-13 relay in the FT 32 case - DC supply - For two terminal lines.

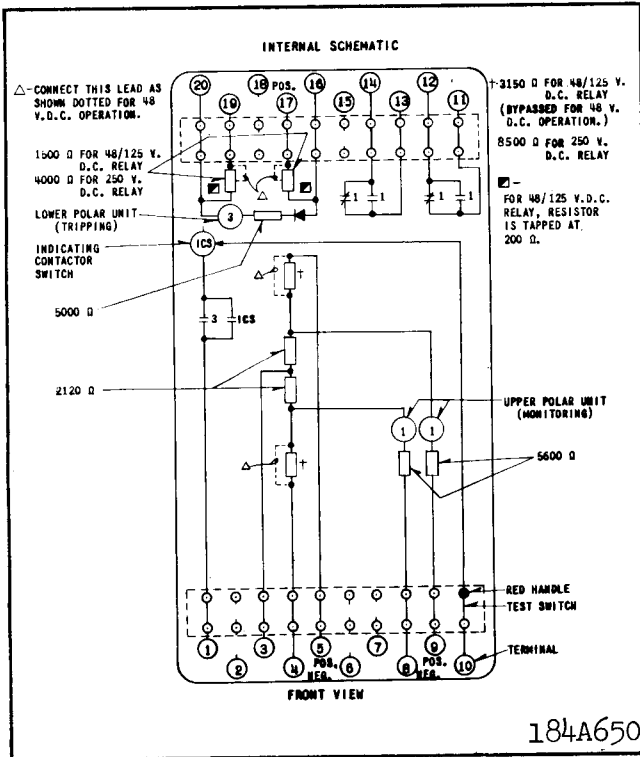

Fig. 16. Internal schematic of the type PM-13 relay in the FT 32 case - DC supply - For three terminal lines.

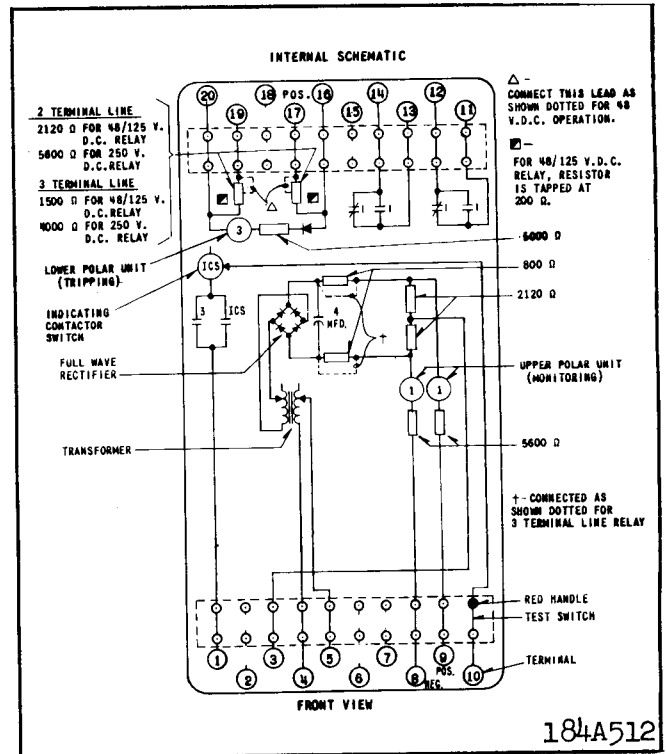

Fig. 17. Internal schematic of the type PM-13 relay in the FT 32 case - 120 volt, 60 cycle supply - For two or three terminal lines.

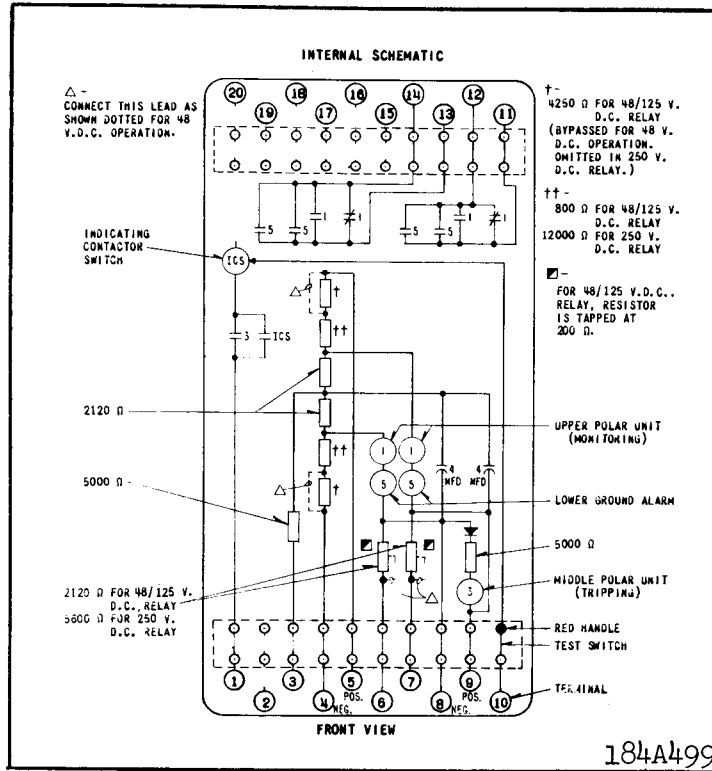

Fig. 18. Internal schematic of the type PMG-13 relay in the FT 32 case - DC supply - For two terminal lines.

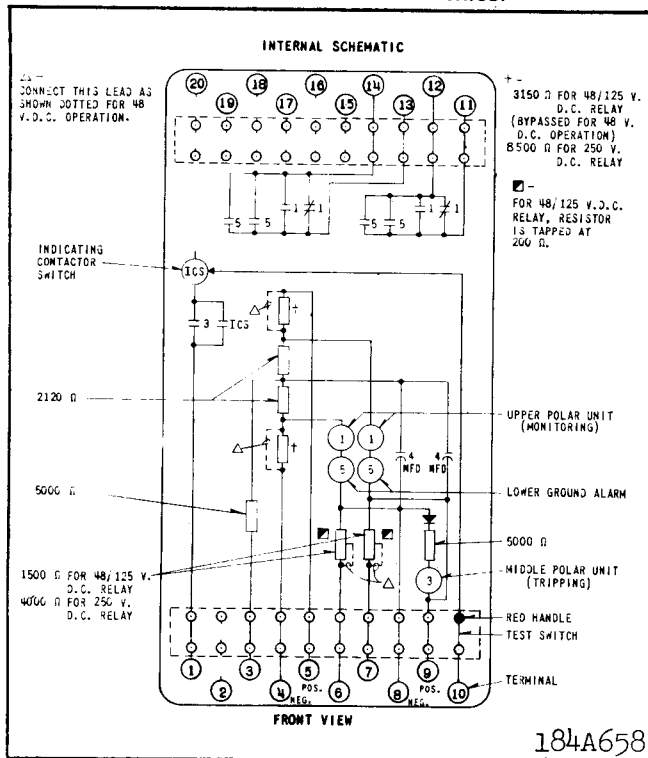

Fig. 19. Internal schematic of the type PMG-13 relay in the FT 32 case - DC supply - For three terminal lines.

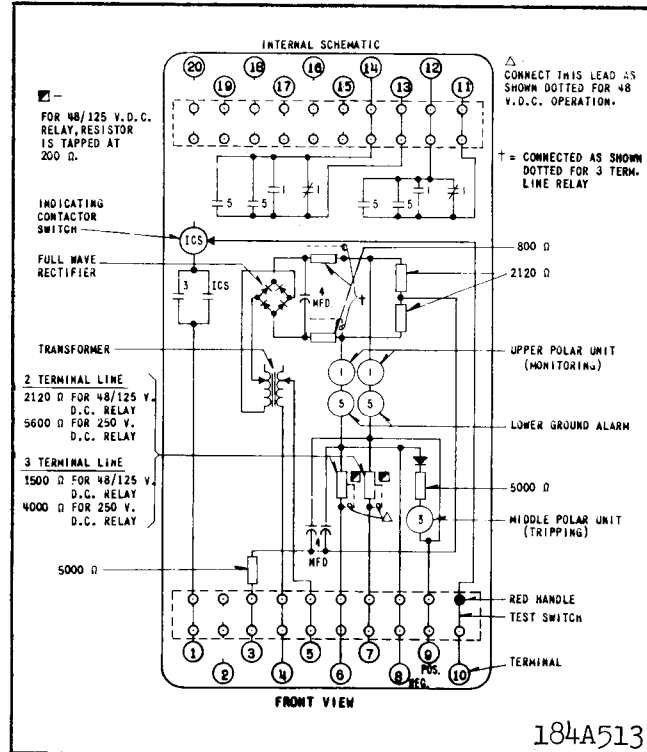

Fig. 20. Internal schematic of the type PMG-13 relay in the FT 32 case - 120 volt, 60 cycle supply - For two or three terminal lines.

TYPE PM MONITORING RELAYS

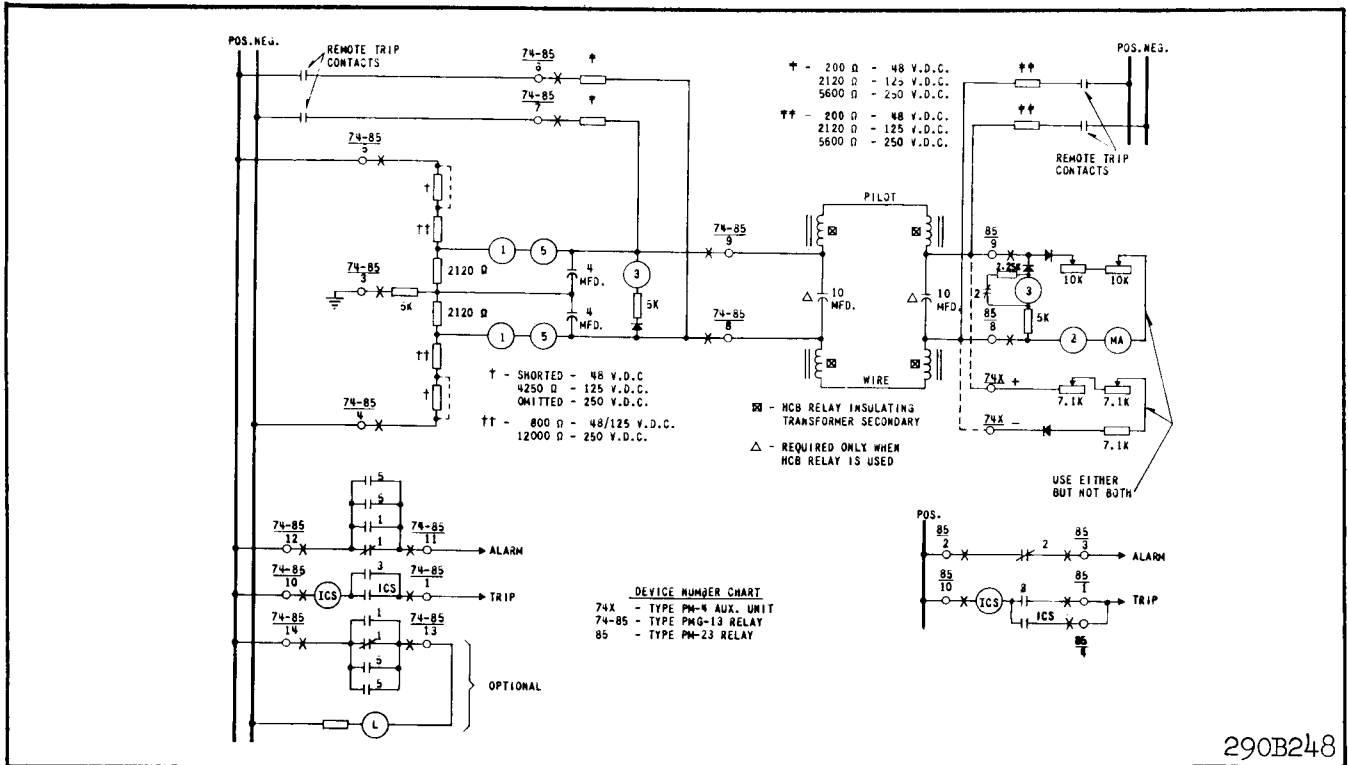

Fig. 23. External schematic of the DC type PMG-13 relay with type PM-23 or PM-4 relay - Two terminal lines.

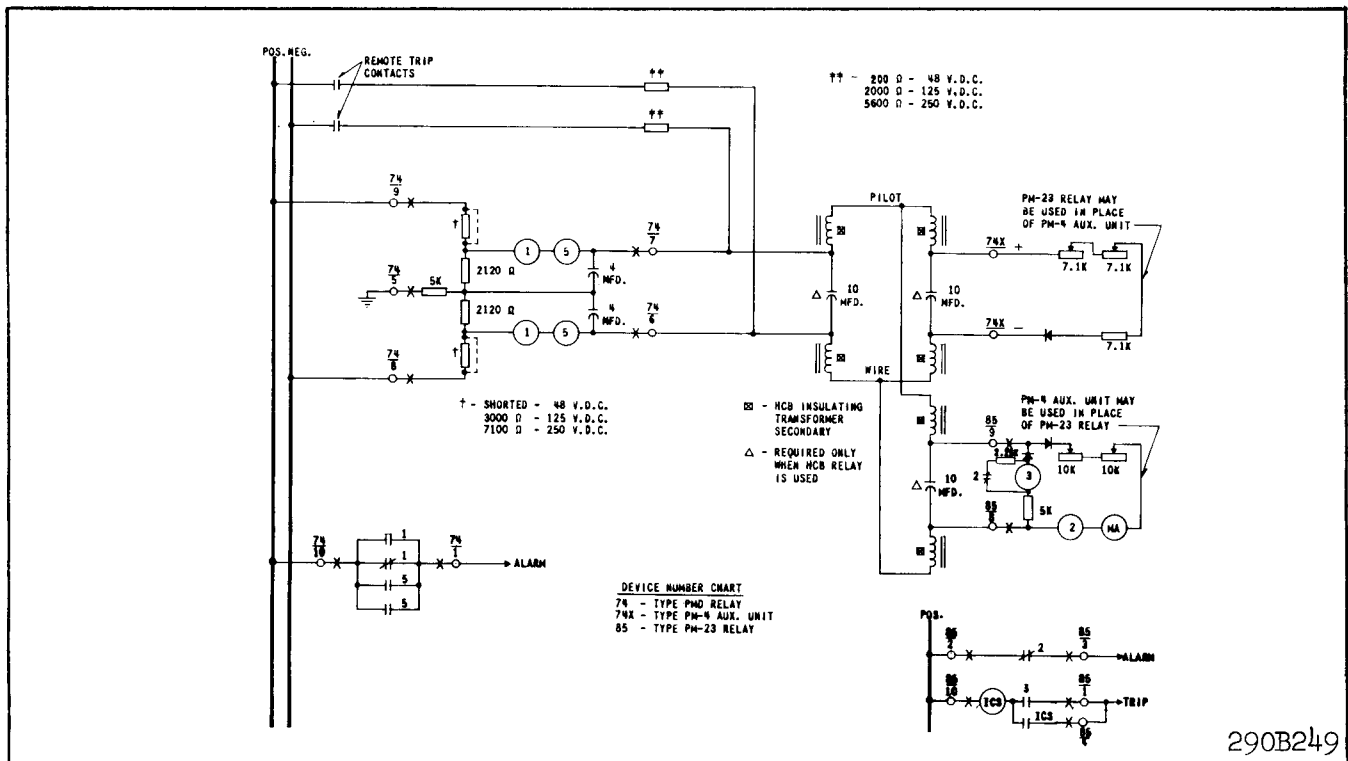

Fig. 24. External schematic of the type PMD relay with type PM-23 and PM-4 relays - Three terminal lines.

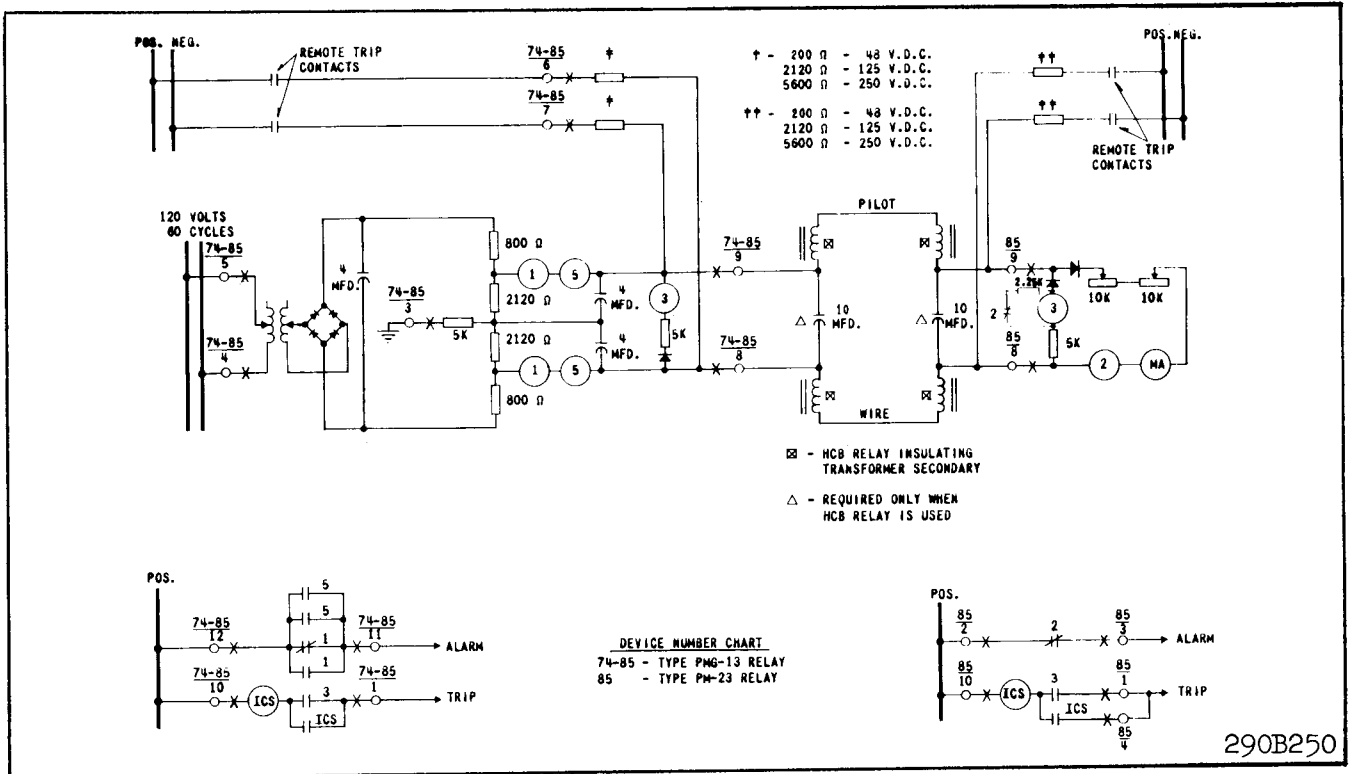

Fig. 25. External schematic of the AC type PMG-13 with type PM-23 relay - Two terminal lines.

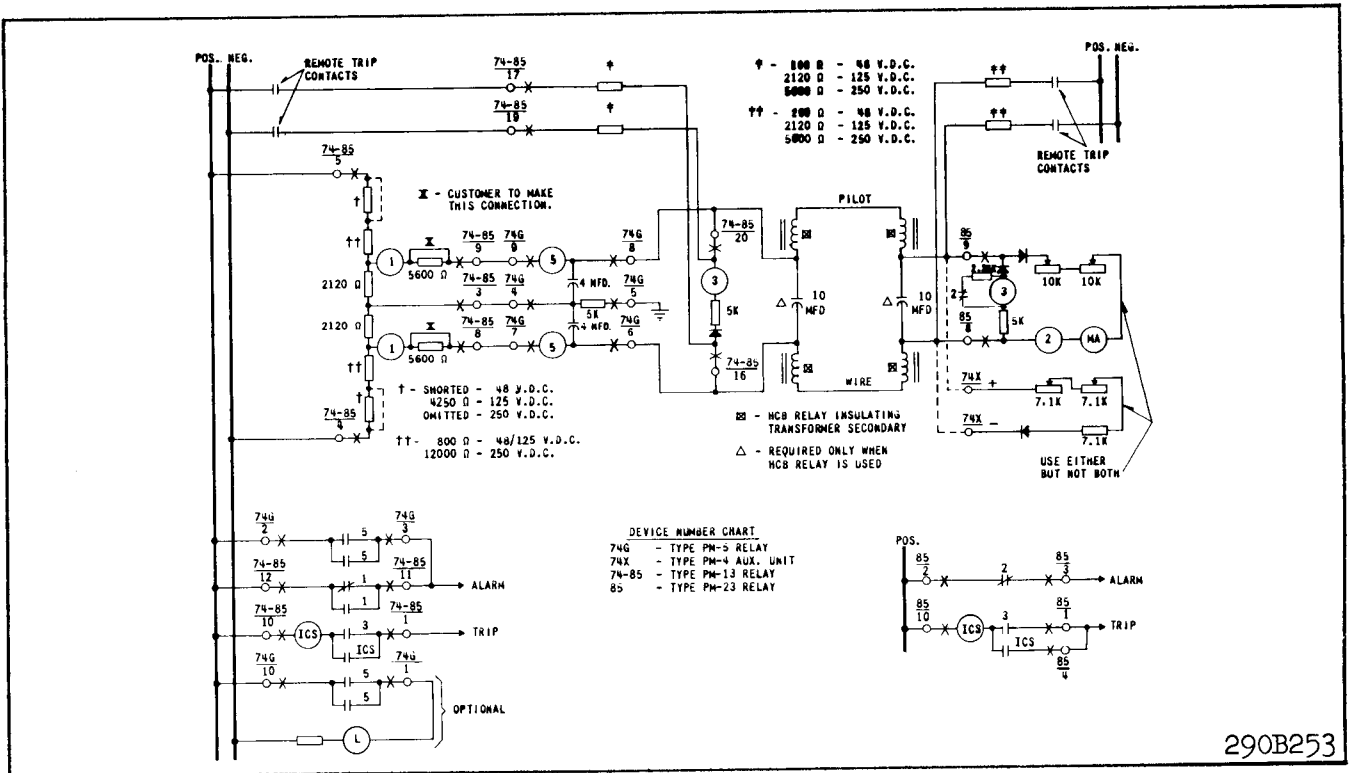

Fig. 26. External schematic of the DC type PM-13 and PM-5 relay with type PM-23 or PM-4 relay - Two terminal lines.

TYPE PM MONITORING RELAYS

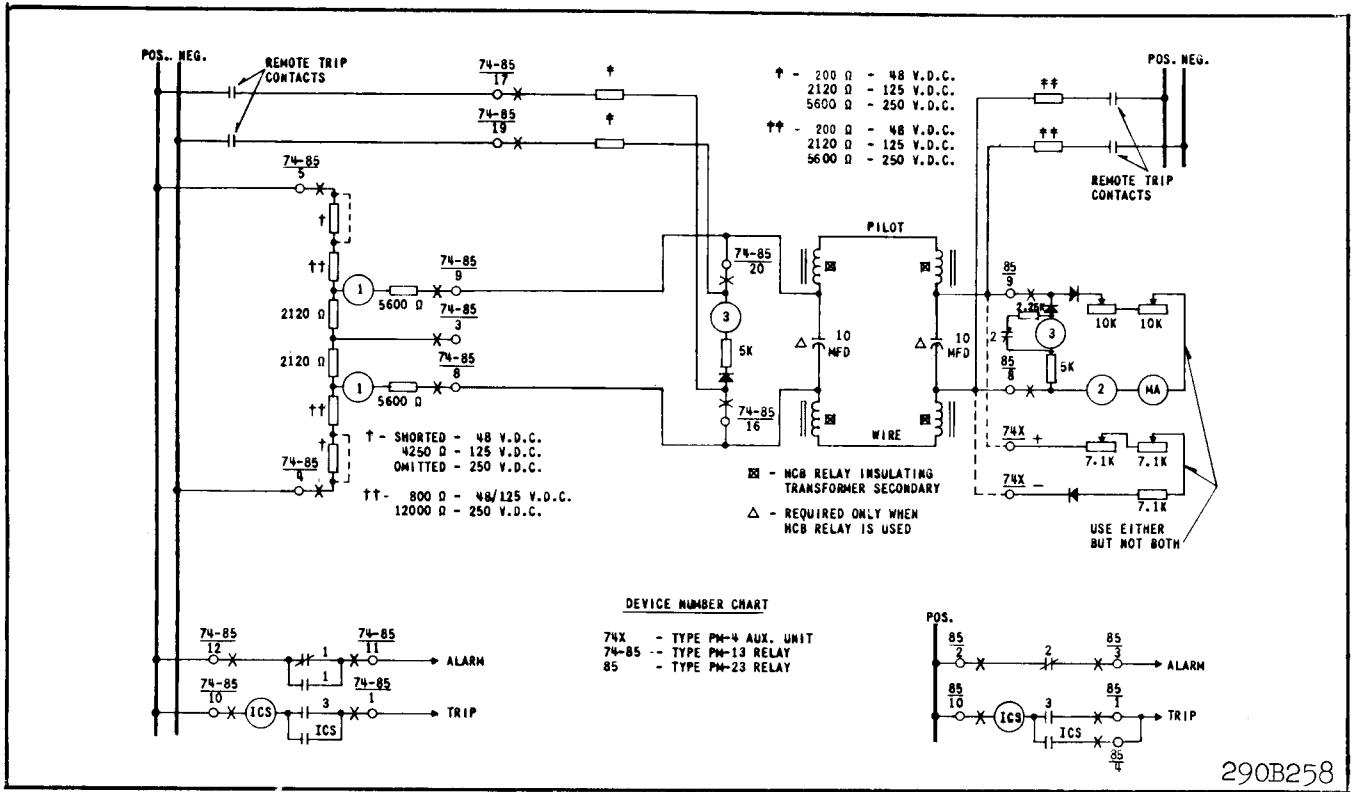

Fig. 27. External schematic of the DC type PM-13 relay with type PM-23 or PM-4 relay – Two terminal lines.

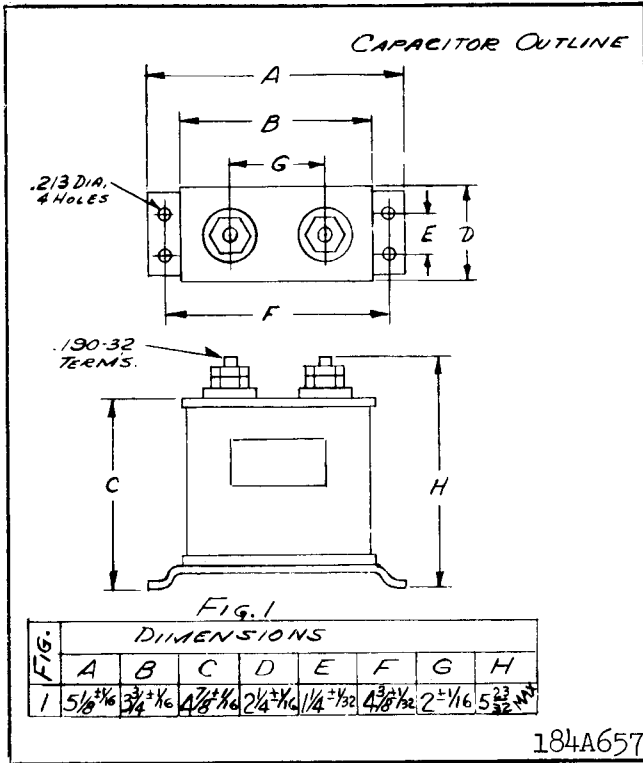

Fig. 28. Outline and Drilling Plan for 10 mfd. capacitor – For reference only.

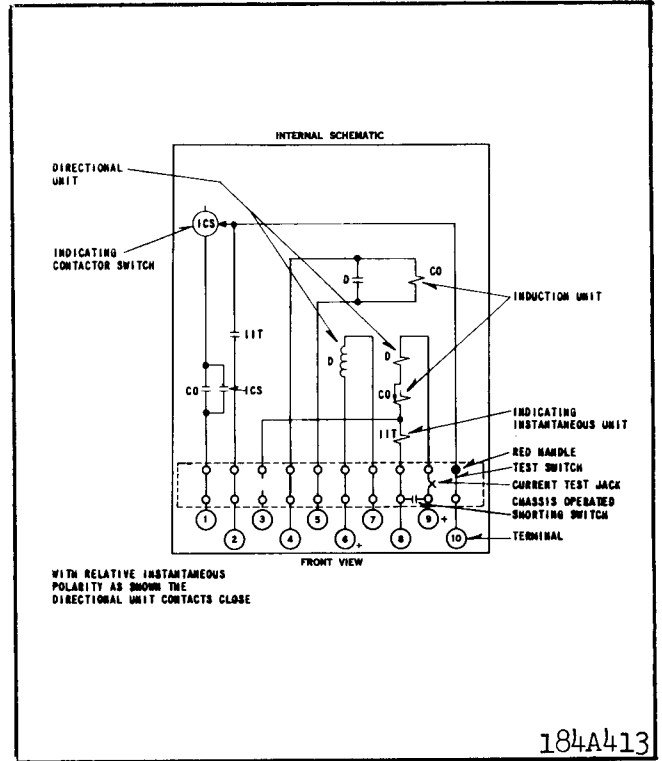

Fig. 29. Outline and Drilling Plan for External Remote Trip Resistor Assembly.

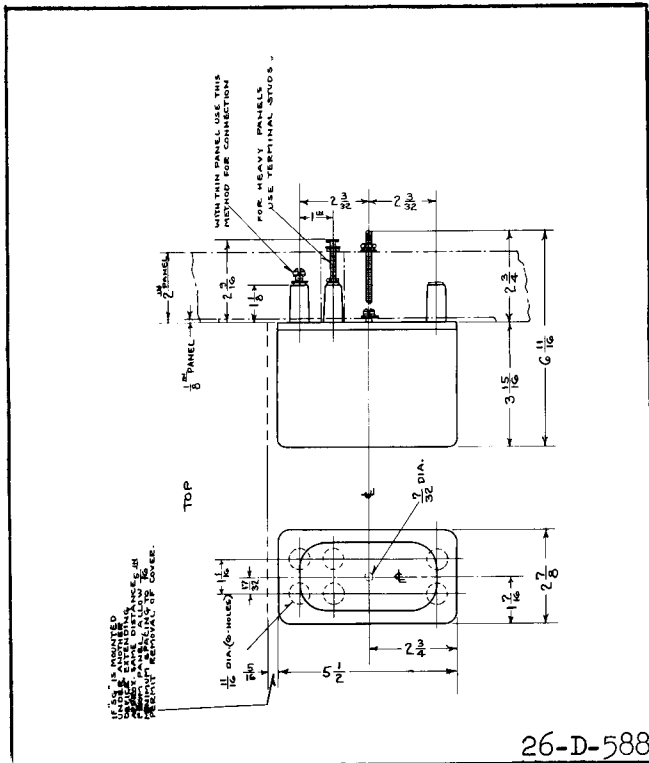

Fig. 30. Outline and Drilling Plan for the type PM-4 Auxiliary unit in the projection molded case.

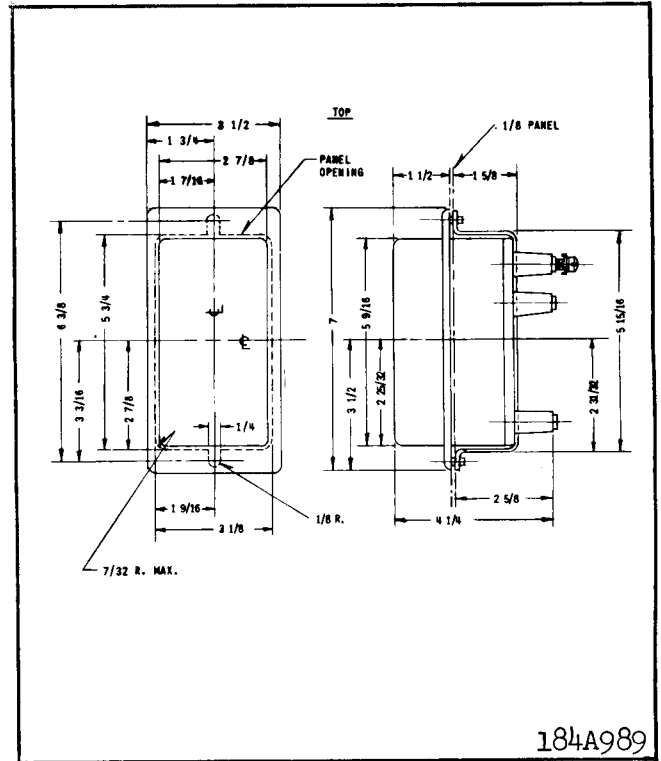

Fig. 31. Outline and Drilling Plan for the type PM-4 Auxiliary unit in the Semi-Flush molded case.

TYPE PM MONITORING RELAYS

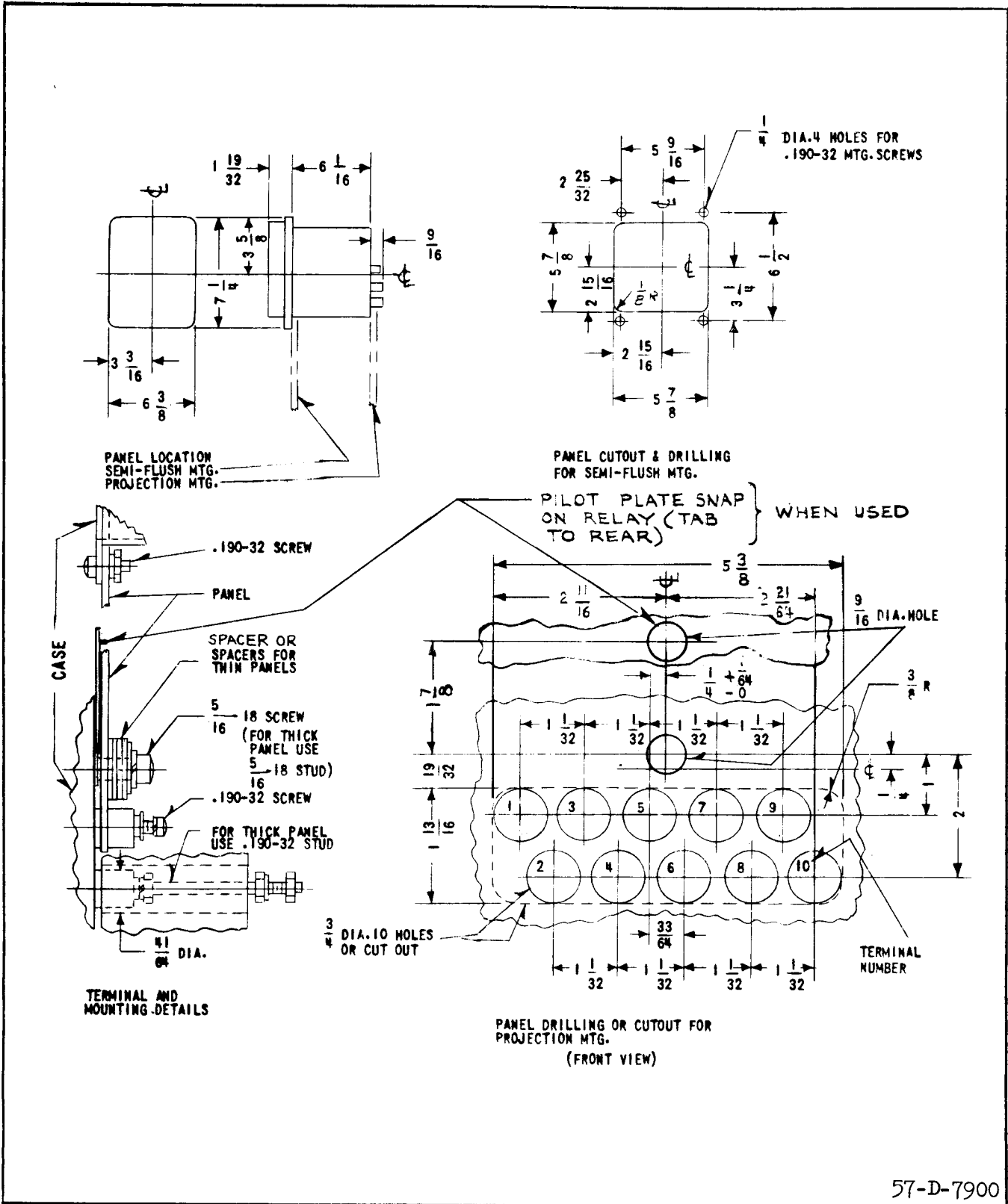

Fig. 32. Outline and Drilling Plan for the type PM-3, PM-5, & PMD-1 Relays in the type FT 11 case.

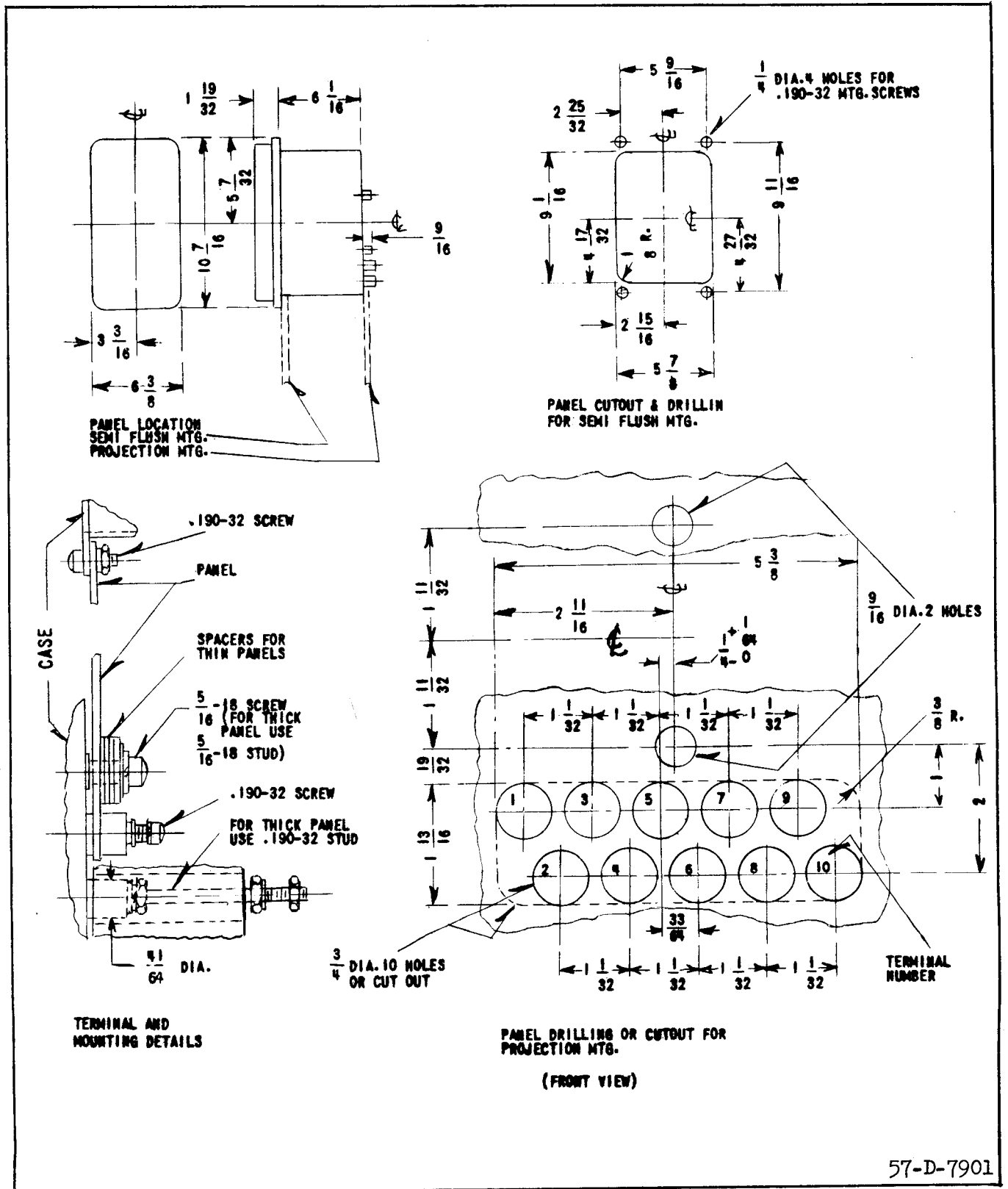
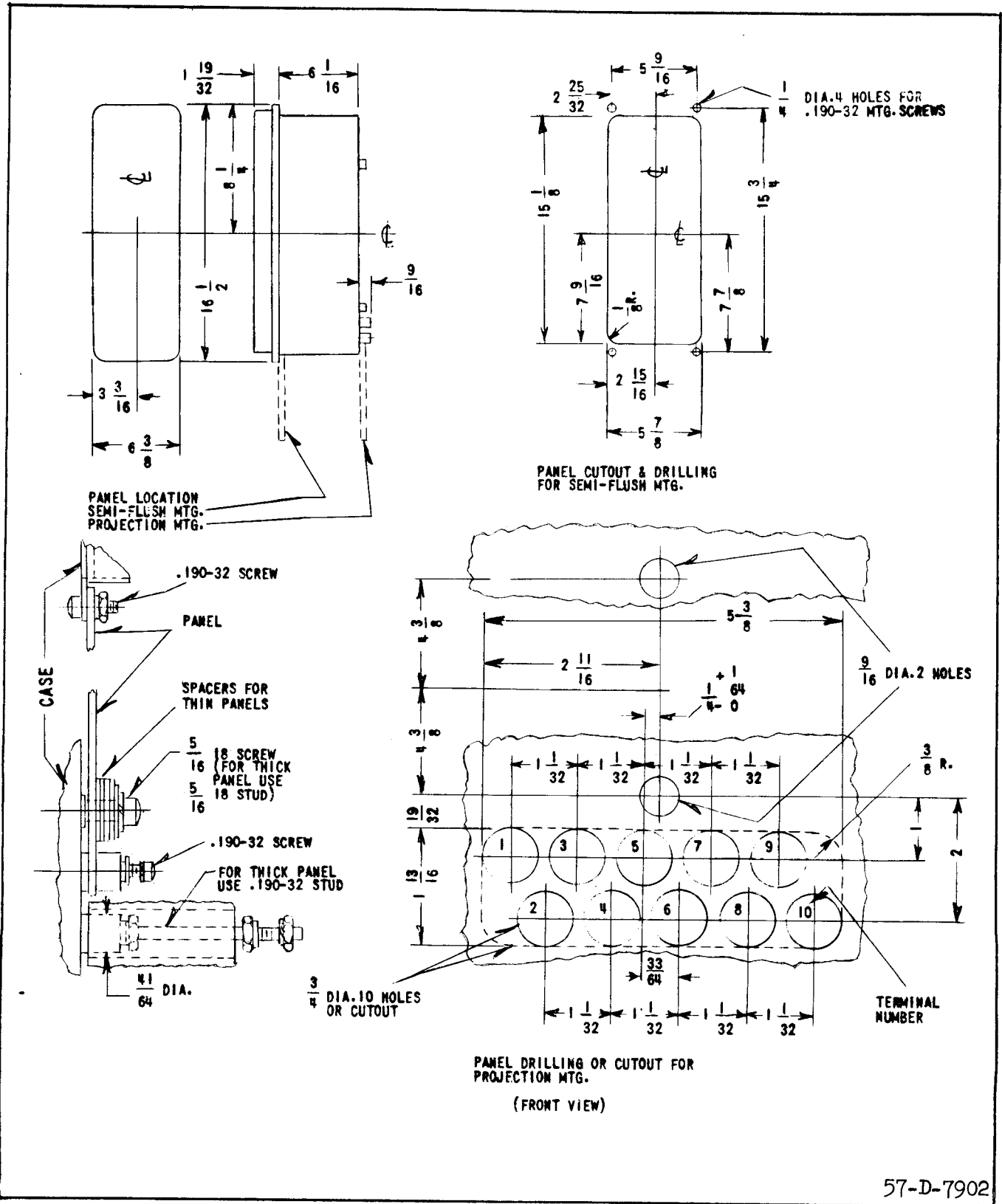

Fig. 33. Outline and Drilling Plan for the type PM-2, PM-23, PMA-1 and PMD relays in the type FT 21 case.



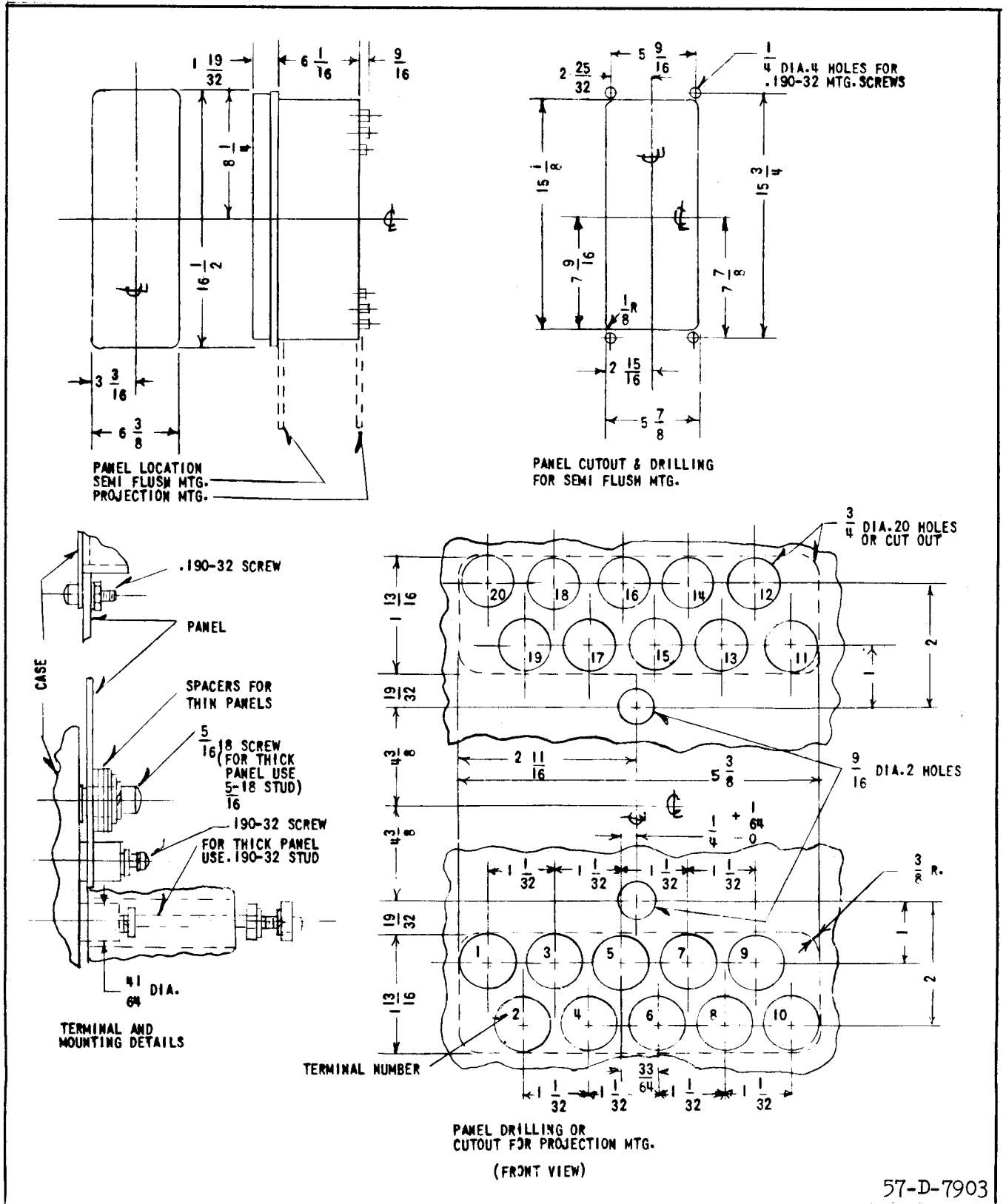
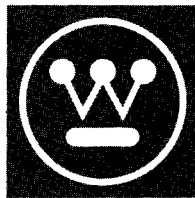

Fig. 35. Outline and Drilling Plan for the type PM-13 and PMG-13 relays in the type FT 32 case.



WESTINGHOUSE ELECTRIC CORPORATION
RELAY-INSTRUMENT DIVISION

NEWARK, N. J.

Printed in U.S.A.