

PRODUCT INFORMATION

051L05002
 GBG 18-07-88

SF6-CIRCUIT-BREAKER TYPE HPL 362-550/25B2-31B2
 WITH 3 OPERATING DEVICES TYPE BLG 1002

DESCRIPTIONS

High voltage circuit-breaker type HPL	(5452 018E-1)	<u>051L05101</u>
Functional values	(5452 019E-8)	<u>051L05110</u>
Lubricants	(5409 506E)	<u>051L05103</u>

ERECTION MANUALS

Erection manual for SF6 circuit-breaker type HPL 362-550/25B2-31B2	(5452 015E-10)	<u>051L05111</u>
---	----------------	------------------

SERVICE AND MAINTENANCE INSTRUCTIONS

Maintenance instructions for HPL CB:s	(5409 719E-1)	<u>051L05105</u>
Instruction for overhaul HPL 362-550/25B2-31B2	(5409-720E-4)	<u>051L05112</u>

PRODUCT INFORMATION

Motor-operated spring closing device type BLG 1002	(5432 165E-5)	<u>051L05107</u>
---	---------------	------------------

SPARE PARTS

HPL362-550/25B2-31B2	(5409 724-8)	<u>051L05113</u>
BLG 1002	(5409 723-1)	<u>051L05109</u>

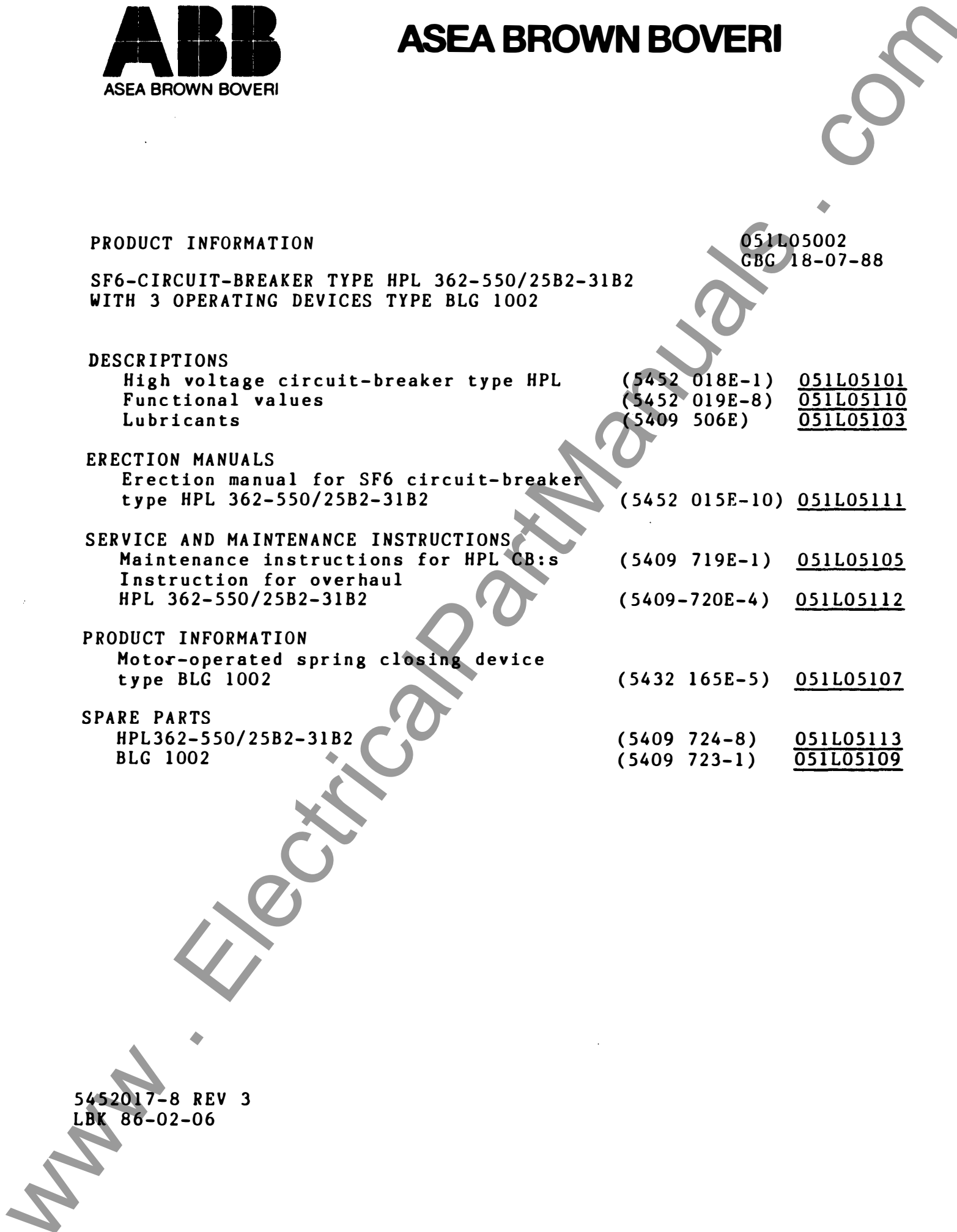

DESCRIPTION

HIGH VOLTAGE CIRCUIT-BREAKER TYPE HPL

The high voltage circuit-breaker type HPL is a detached SF6-circuit-breaker of so-called puffer type for outdoor erection in open substations.

The circuit-breaker is built up of 3 separate poles, which consist of 3 main parts:

Lowest down the operating mechanisms in housings of light metal, above hollow support insulators through which run operating insulators, and highest up the breaking units. Each breaking unit consists of a hollow insulator which, together with an upper and a lower flange, constitute the casing, and a lower and an upper current path with contact system. The moving contacts are mounted on the lower current path, on the so-called puffer, whereas the fixed contacts are mounted on the upper one. In the case each breaker pole contains more than one breaking unit a grading capacitor is connected in parallel over each unit.

The circuit-breaker poles are permanently filled with SF6-gas, normally to the pressure 72.5PSI absolute at 68°F. For monitoring of the pressure, the poles are furnished with density monitors.

The poles are mounted on separate column frameworks, welded of angle-iron and hot-dip galvanized.

The pressure rise and gas flow which are necessary for extinguishing the arc during the course of breaking are produced by the "puffer", in principle a pump where the piston is fixed and the cylinder movable and via the operating insulator joined to the mechanical operating system.

At opening operation the puffer cylinder is pulled downwards over the fixed piston, and the confined quantity of gas is compressed and forced at high speed out through the openings in the upper end of the cylinder. At the same stage the arcing contacts are separated and an arc occurs. A specially formed nozzle leads the out-flowing gas towards the arc. The gas is allowed to pass both downwards through the moving arcing contact and upwards past the fixed arcing contact.

For the current transmission there are separate contacts which are not affected by the arc at breaking.

At closing operation the puffer cylinder is pushed upwards, at which time the contacts engage and the cylinder is again filled with gas.

FUNCTIONAL VALUES

SF6 CIRCUIT-BREAKER TYPE HPL 362-420/25B2-31B2
WITH OPERATING MECHANISM TYPE BLG 1002

Closing time	max. 90 ms
Opening time coil I	$22+3$ ms (max 21.5 ms) **
Opening time coil II	$23+3$ ms (max 21.5 ms) **
Close-open *	max. 60 ms

Resistance of the main circuit across the breaking unit
max 72 at rated current = 2500 A
max 50 at rated current = 3150 A

*) Close-open time means the time during which the main contacts are closed at a closing operation when the tripping impulse is connected in simultaneously, via the auxiliary contact.

**) For 2 cycle circuit-breakers

TYPES OF LUBRICANTS FOR SWITCHING DEVICES

As a guide to the selection of lubricants and oils, a description is given below of the range of application together with a list of suppliers arranged in alphabetical order and their trade names.

Oil "A":

Thin lubricating oil for precision parts in operating devices and air-blast circuit-breakers. Also for relubricating of bearings, which can not be lubricated with grease G without dismounting - e.g. links and link gears. Viscosity at 122°F: 8±2 cSt.

Oil "C":

Circuit-breaker oil with viscosity - 17 cSt at 68°F. Suitable only for temperatures > -14°F.

Oil "D":

Circuit-breaker oil with low viscosity - 6.0 cSt. at 68°F shall also be used as oil in dashpots. For dashpots with the letter "S" stamped on the cover - oil "S" shall be used.

Oil "S":

Silicon oil intended for oil dashpots in heavy operating mechanisms. Only dashpots with the letter "S" stamped on the cover shall be filled with this oil.

Grease "G":

Low temperature grease for all types of bearings, gears and worm gears as well as valves in air-blast circuit-breakers. Also suitable for lubrication of silver-plated contacts in air (e.g. contact in disconnectors).

Grease "K":

For lubrication of moving contacts in SF6-insulated circuit-breakers (e.g. puffer cylinders).

The grease shall be rubbed very thin on the sliding surface of the contacts.

Grease "L":

Low temperature grease specially suitable for lubrication of fine mechanics - e.g. catch devices in operating mechanisms which shall operate in strong cold.

	Grease "G"	Grease "K"	Grease "L"
ASEA NO.	1171 4014-407	1171 4014-301	1171 4106-606
ASEOL AG	--	--	ASEOL SYLITEA 4-018
GULF	718EP Sythetic grease	--	--
MOBIL	Mobilgrease 28	--	--
SHELL	Areo Shell Grease 22	Alvania Grease G2	--

Note! Grease "E", "F" and "H" are from 1986-10-01 replaced by grease "G".

ERECTION MANUAL

SF6 CIRCUIT-BREAKER TYPE HPL 245-550/31B2-40B2

WITH OPERATING DEVICE TYPE BLG 1002

ONE DENSITY SWITCH PER POLE

DESIGNATIONS AND REFERENCES

When ordering spare parts and in inquiries and other correspondence, the type designation and manufacturing number of the circuit-breaker according to its rating plate, the number of this Manual and the designation of the parts concerned shall be given as in the following example:
Mechanism housing 051L05111-F-14.

LIST OF CONTENTS

Erection	Page 2
Mounting Marking	3
Foundation	3
Assembly of framework	4
Mounting of support insulator unit on framework	5
Mounting of T-breaking unit	6
Mounting of operating device	13
Mounting of pull rods and protective tubes	14
Releasing of operating arm	15
Tripping device	15
Pressurizing, preparation	16
Gas filling with SF6	16
Pressure values for SF6 gas filling	19
Mounting of density switches	20
Tightness check	20
Electrical joint compound	21
Check prior to taking into service	22

NOTE THE CIRCUIT-BREAKER SHALL NOT BE OPERATED WITH THE OPERATING DEVICE BEFORE BEING FILLED WITH GAS.

THE OPERATING DEVICE SHALL NOT BE OPERATED BEFORE IT HAS BEEN CONNECTED TO THE CIRCUIT-BREAKER AND THE ROD SYSTEM HAS BEEN ADJUSTED IN ACCORDANCE WITH THIS MANUAL.

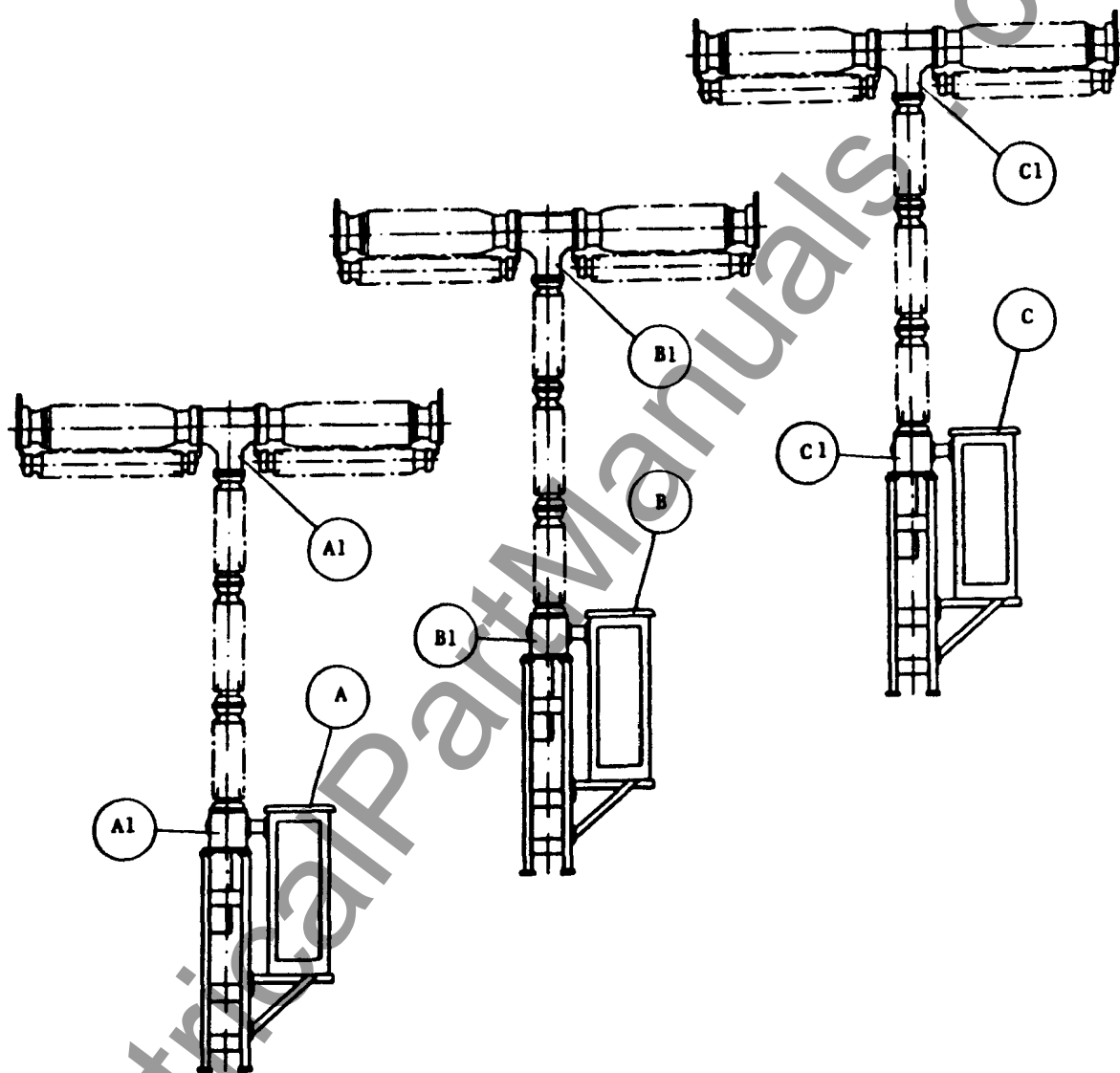

Figure A HPL 245-550/31B2-40B2
Three-pole circuit-breaker
mounted on a column frame
Single-pole operated

Mounting marking

The circuit-breaker is, when delivered, dismantled into a few transport units. The component parts are marked in order to facilitate mounting. The circuit-breaker poles and the operating device have been tested together and are mounting marked as shown in Figure A.

The T-breaking unit and the support insulator are delivered in separate gas-tight units which only require mechanical interconnection and then gas filling. The T-breaking unit and the support insulator with the same marking, e.g. A1, shall be connected together.

Foundation

The foundation of the circuit-breaker shall be level and horizontal. Any deviations shall be adjusted with spacer washers.

Figure B shows the permissible deviations in inches for the position of the foundation screws. The nominal dimensions are given on the applicable dimension print.

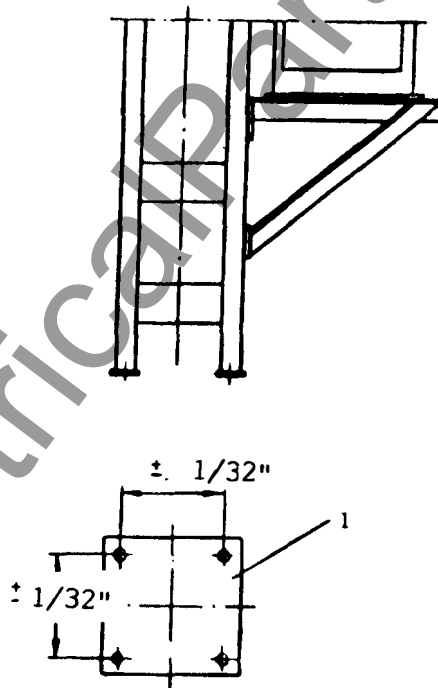

Figure B Tolerance for foundation screws	
B-1	Foundation for circuit-breaker pole

Assembly of framework

The following procedure is recommended for mounting of the framework on the foundation.

Figure C

C-1	Framework foot
C-2	Bolt M24; L min = 4.5"
C-3	Nut (tightening torque 220 Ft-lb.)
C-4	Disc 1"FW
C-5	Foundation
C-6	Spacer washers (do not accompany the delivery)

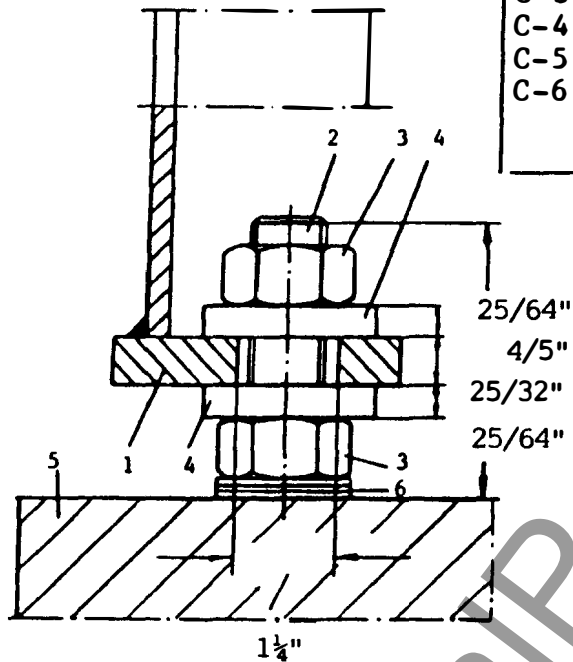

With the nuts C-3 an adjustment shall be made of the frameworks so that they are at the same height and are perpendicular.

The gap between the lower nut C-3 and the foundation should be as small as possible and shall be filled in with the spacer washers C-6. The nut C-3 shall be tightened against the spacer washer. The final tightening of the framework shall be made with the upper nut C-3. The spacer washers C-6 do not accompany the delivery.

Mounting of support insulator unit on framework

Every support insulator unit shall be checked for any leakage which may have occurred during transport, before being mounted on the framework. The check shall be carried out by means of removing the tightening cap D-6 and pressing the disc of the check valve inwards with a pin approximately 3/8". A distinct hiss should then be heard from the pole. If no hiss is heard, there is a leak in the support insulator, which must be attended to. Remount the tightening cap D-6.

On every framework a support insulator unit shall be mounted as shown in Figure D. The screw D-1 shall be mounted by hand only. Note how the support insulator unit is slung. The support insulator unit shall be lifted in this way from its horizontal position in the transport package.

Mass-1100Lb.

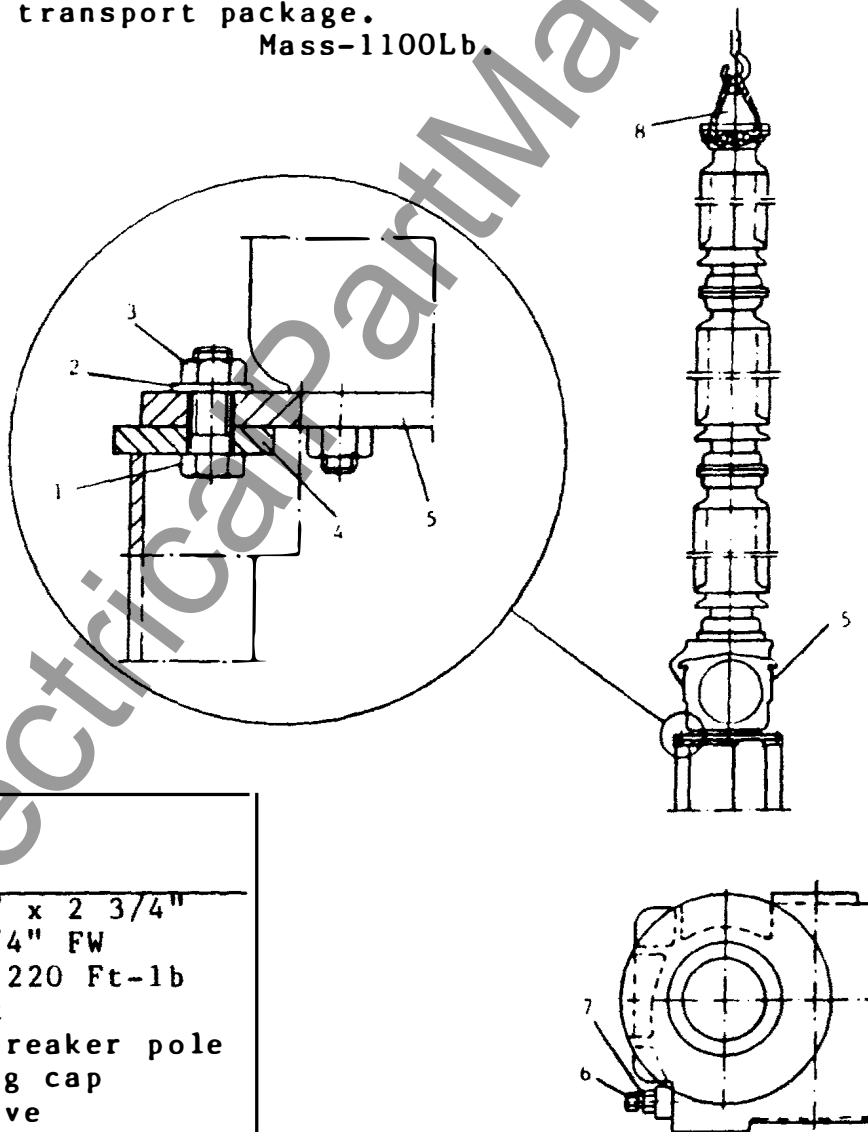

Figure D

D-1	Bolt 3/4" x 2 3/4"
D-2	Washer 3/4" FW
D-3	Nut 3/4" 220 Ft-1b
D-4	Framework
D-5	Circuit-breaker pole
D-6	Tightening cap
D-7	Check valve
D-8	Transport cover

Mounting of T-breaking unit

The T-breaking unit shall be slung and lifted as shown in Figure DA.

Mass 2425Lb. without preinsertion resistor
Mass 3086LB. with preinsertion resistor

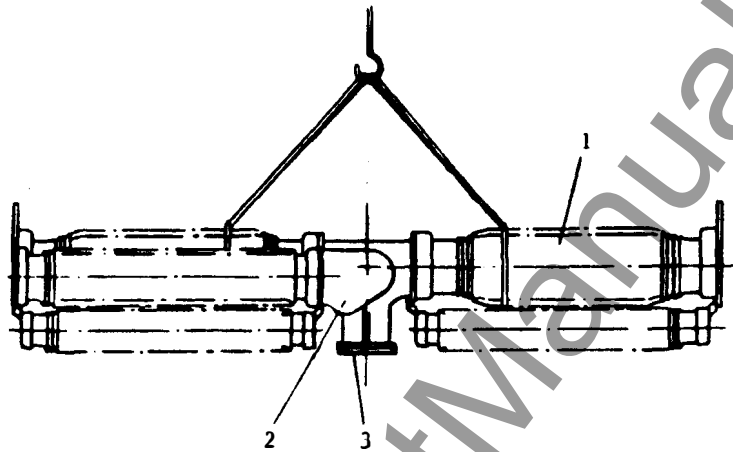

Figure DA

DA-1	T-breaking unit with capacitors
DA-2	Preinsertion resistor (when required)
DA-3	Transport cover

The T-breaking unit shall be lifted. Before the T-breaking unit DB-1 is mounted on the support insulator DB-2 the transport covers DB-3 and DB-7 shall be removed. The transport covers DB-3 and DB-7 shall be kept for any future overhauls. Remove the tightening cover DB-11 also.

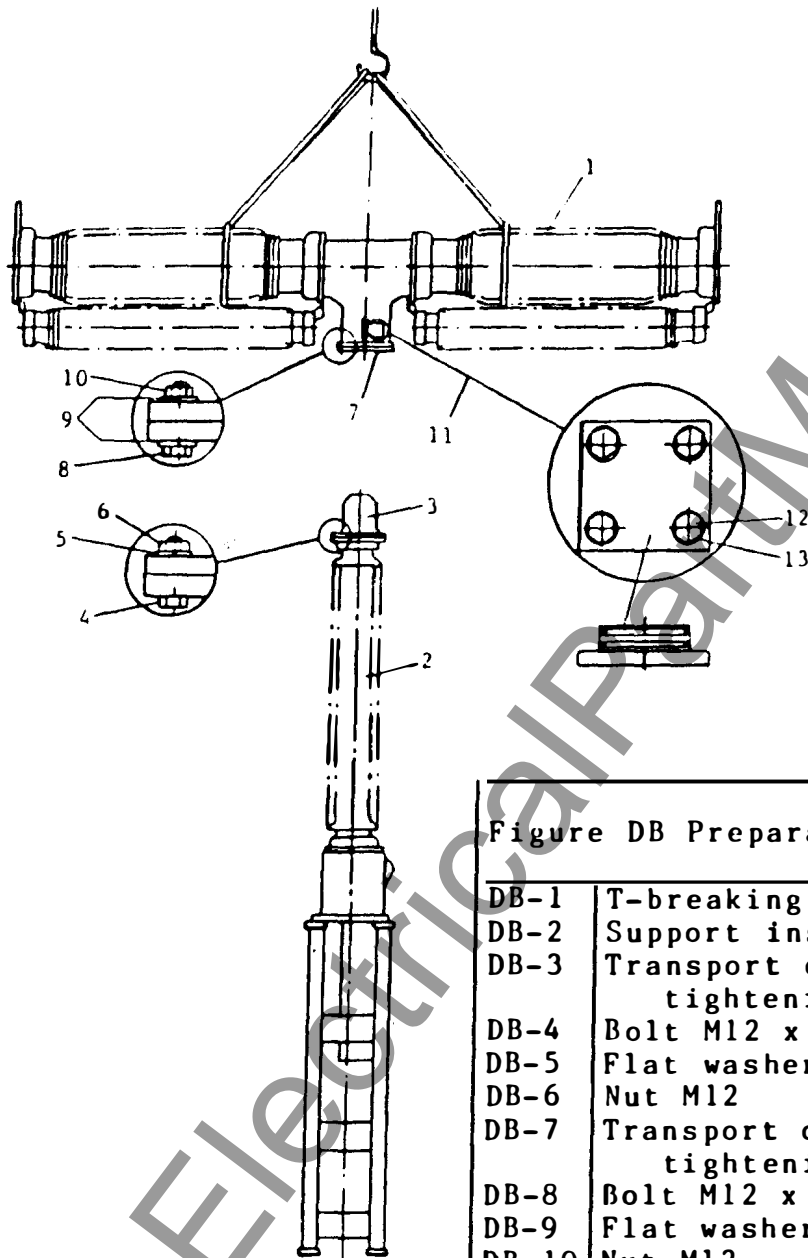

Figure DB Preparation for mounting

DB-1	T-breaking unit with capacitors
DB-2	Support insulator unit
DB-3	Transport cover with O-ring tightening 180 x 5.7
DB-4	Bolt M12 x 60
DB-5	Flat washer 13 x 24 x 2
DB-6	Nut M12
DB-7	Transport cover with O-ring tightening 170 x 5.7
DB-8	Bolt M12 x 50
DB-9	Flat washers 13 x 24 x 2
DB-10	Nut M12
DB-11	Tightening cover with two O-rings 64.5 x 3
DB-12	Bolt M10 x 25
DB-13	Flat washer 10.5 x 22 x 2

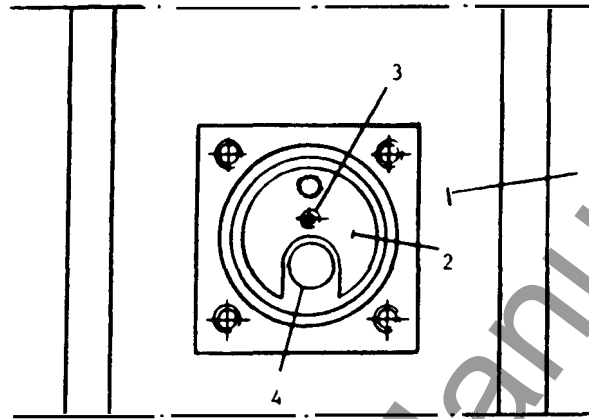

Figure DC After dismounting of tightening cover DB-11

DC-1	T-mechanism housing
DC-2	Lock washer for tightening position in T-breaking unit
DC-3	Screw thread M8 for dismounting of lock washer DC-2
DC-4	Hole for interconnection with DD-5

Let the lock washer DC-2 remain, as it still keeps the contact system of the T-breaking unit in the tightening position.

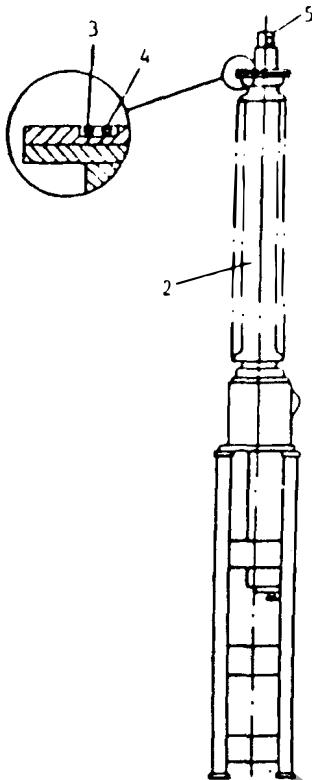
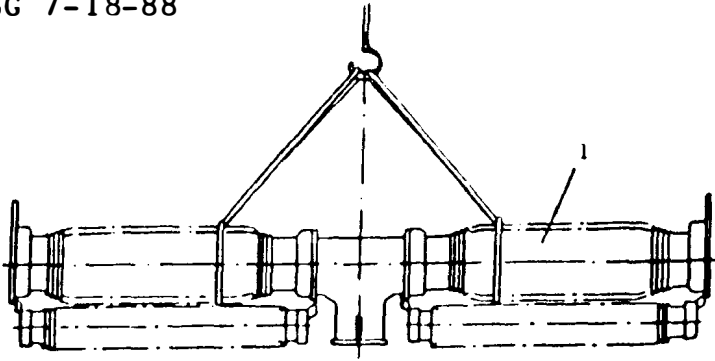

Figure DD Mounting of T-breaking unit

DD-1	T-Breaking unit
DD-2	Support insulator unit
DD-3	O-ring 180 x 5.7
DD-4	O-ring 170 x 5.7
DD-5	Operating insulator which shall be connected to DC-4

Place the O-rings DB-3 and DB-7 on the upper flange of the support insulator unit according to DD-3 and DD-4.

Check first that the O-rings and tightening surfaces are well cleaned, and lubricate the O-rings with Grease E.

Lower the T-breaking unit DD-1 carefully against the support insulator unit DD-2.

Check that the movable part of the T-breaking unit centers well with the operating insulator DD-5, and that the O-rings DD-3 and DD-4 are in their correct tightening position.

Let the T-breaking unit be definitively lowered against the support insulator unit.

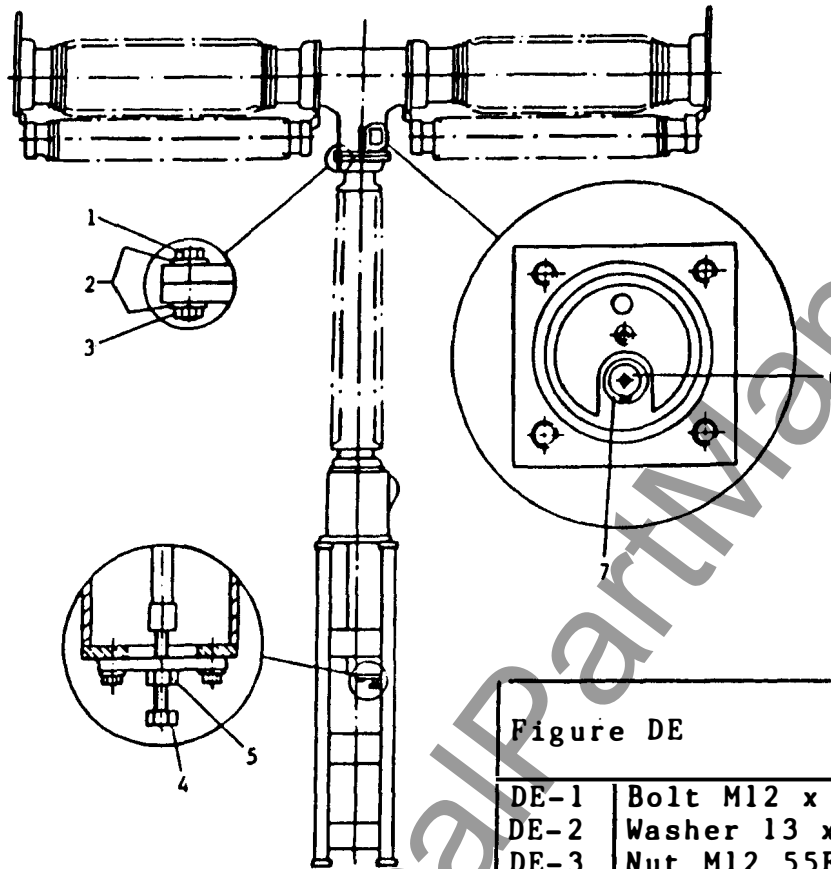

Figure DE

DE-1	Bolt M12 x 60
DE-2	Washer 13 x 24 x 2
DE-3	Nut M12 55Ft-1b.
DE-4	Bolt M16 x 90
DE-5	Nut M16
DE-6	Pin 022 for interconnection of the contact system in the T-breaking unit with the operating insulator
DE-7	Retaining ring for pin DE-6

Connect the T-breaking unit to the support insulator unit with the bolt, washer and nut DE-1, DE-2 and DE-3.

When necessary, the operating insulator DD-5 can be adjusted vertically with the bolt DE-4 after the nut DE-5 has been loosened.

Mount the pin DE-6 and the retaining ring DE-7. Check carefully that the retaining ring goes correctly into its slot.

Thread a screw M8 into the lock washer DC-2 and pull out the lock washer. See Figure DF.

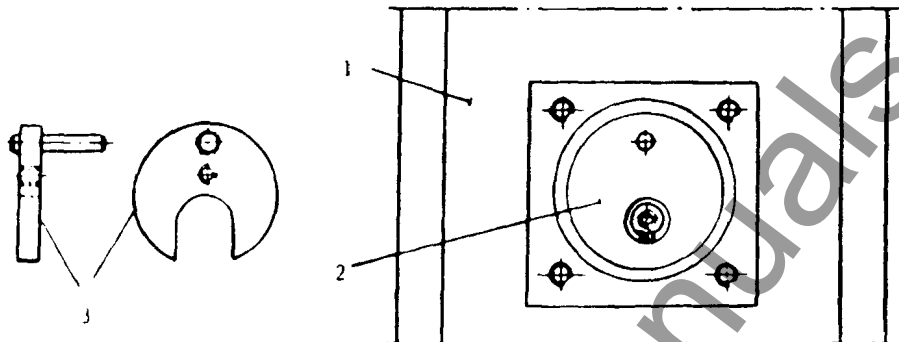

Figure DF Lock washer DC-2 removed

DF-1	T-mechanism housing
DF-2	Interlinked contact system with operating insulator
DF-3	Removed lock washer DC-2

Remount the cover DB-11 carefully, without damaging the tightening surface. Check first that the O-rings and tightening surfaces are clean and lubricate the O-rings with Grease E.

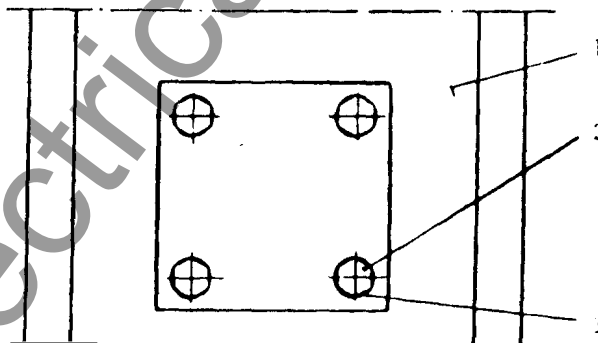

Figure DG Tightening cover

DG-1	T-mechanism housing
DG-2	Bolt M10 x 25 24Ft-1b.
DG-3	Flat washer 10.5 x 22 x 2

The cover of the mechanism housing with window, and plate with "CLOSE" and "OPEN" labels shall be dismantled. A check shall then be made that the coupling piece F-9 is in the position shown in Figure F.

Remove the bolt DH-4 and the nut DH-5. Then dismantle the bolt DH-6, the washer DH-7, the cover DH-2 and the guide sleeve DH-8. The bolt DH-4 and the guide sleeve DH-8 shall be kept for possible future overhaul.

Remount the cover DH-2 on the bottom of the tripping device as shown in Figure DH - detail drawing on the right-hand side.

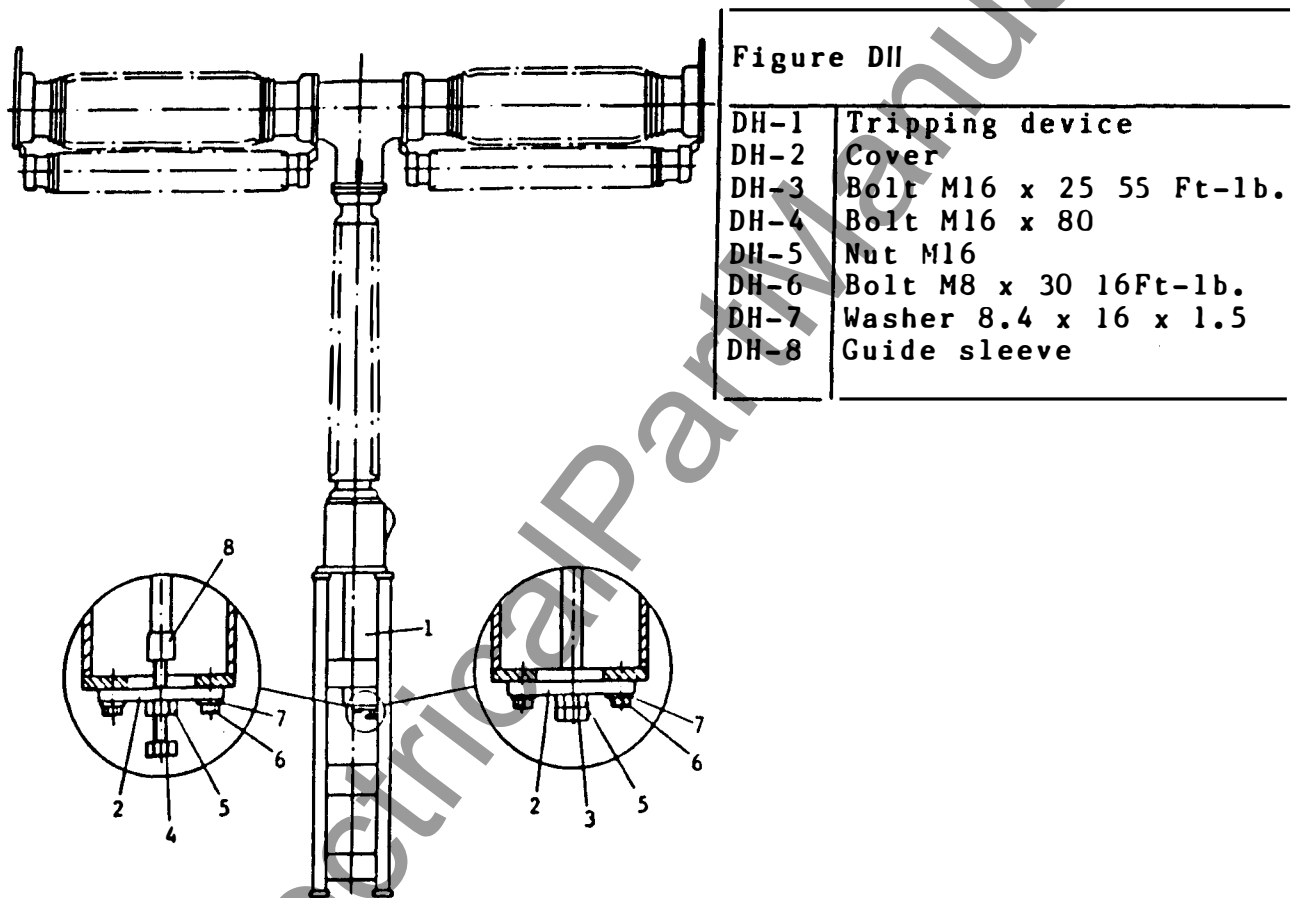

The circuit-breaker shall now be ready for connection to the operating device.

Mounting of operating device

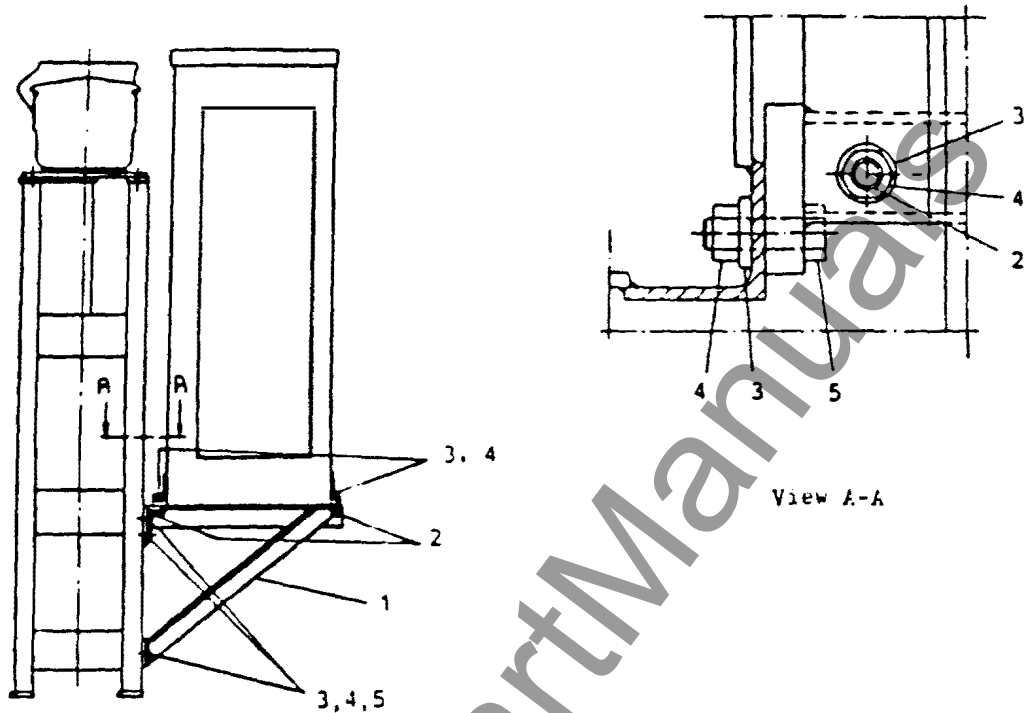

Figure E	
E-1	Bracket
E-2	Bolt 5/8" x 2"
E-3	Washer 5/8" FW
E-4	Nut 5/8" 150Ft-lb.
E-5	Bolt 5/8" x 2"

Mount the bracket E-1 on the framework as shown in Figure E.

Check that the manufacturing number on the operating device agrees with the manufacturing number on the circuit-breaker and that the plate for mounting marking agrees with Figure A.

The operating device shall be mounted on the bracket as shown in figure E.

Wait before finally tightening the four mounting bolts E-2.

Mounting of pull rods and protective tubes

Every pole is, when delivered, adjusted and its open position is determined. No adjustments in the poles are necessary.

Protective tube and pull rod between operating device A and pole A1 shall be mounted.

The work shall be carried out with the spring bridge of the operating device in the fully discharged position or the spring bridge blocked. Lift the roof off the operating device.

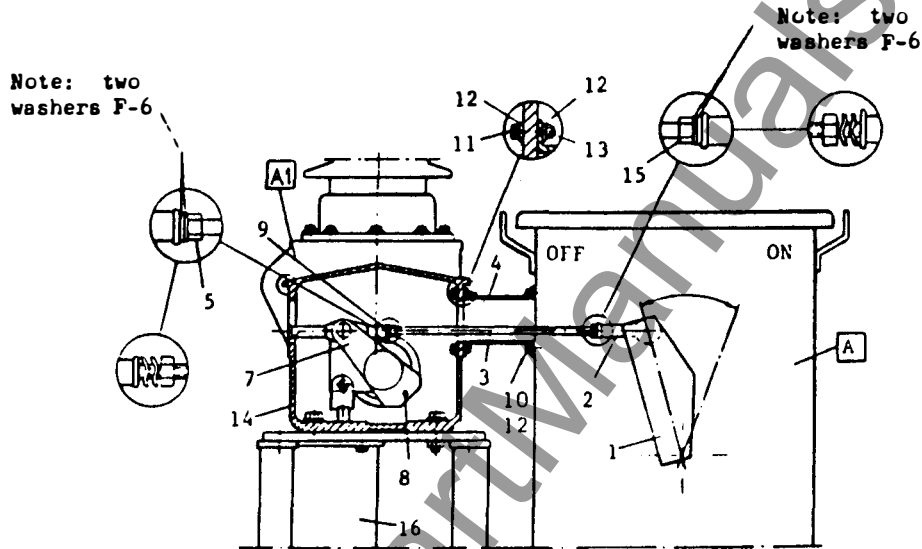

Figure F

F-1	Operating arm	F-9	Coupling piece M24 (left-hand thread)
F-2	Coupling piece M24 (right-hand thread)	F-10	Bolt 1/2" x 2" 55FT-1b.
F-3	Pull rod	F-11	Bolt 1/2" x 2"
F-4	Protective tube 150ft-1b.	F-12	Washer BRIR 1/2" FW
F-5	Lock nut M24	F-13	Nut 1/2" 55Ft-1b.
F-6	Washer BRIF 25	F-14	Mechanism housing
F-7	Arm	F-15	Lock nut M24 150Ft-1b.
F-8	Checking hole in arm F-7	F-16	Opening spring

The protective tube F-4 between the operating device A and the pole A1 shall be mounted according to Figure F.

The pull rod F-3 shall be mounted by means of moving the operating arm F-1 towards its closed position, far enough for the pull rod to come in between and to be able to enter into the coupling pieces F-2 and F-9.

If the operating arm F-1 is blocked in the CLOSE position it shall first be released - see Figure C.

The entry of the pull rod F-3 shall take place simultaneously in the coupling piece F-2 (right-hand threaded) and the coupling piece F-9 (left-hand threaded).

Now the pull rod will be turned so that its length will be decreased, at the same time as the operating arm F-1 goes towards its open position. The correct length of the pull rod F-3 will be obtained when the operating arm F-1 is in its open position (against the cam disc) and the checking hole F-8 of the arm F-7 is directly in front of a prebored hole in the mechanism housing F-14. The open position has been, as was previously mentioned, adjusted prior to delivery.

Check that two lock washers F-6 have been mounted at each lock nut F-5 and F-15. Finally, tighten the lock nuts F-5 and F-15 and the bolts D-1 which hold the circuit-breaker pole to the framework. See Figure D. In addition, tighten the bolts E-2 which hold the operating device to the bracket. See Figure E.

The circuit-breaker poles B and C shall be mounted in the same way.

All the CLOSE and OPEN plates shall be mounted, and then the covers with windows shall also be mounted.

Releasing of operating arm

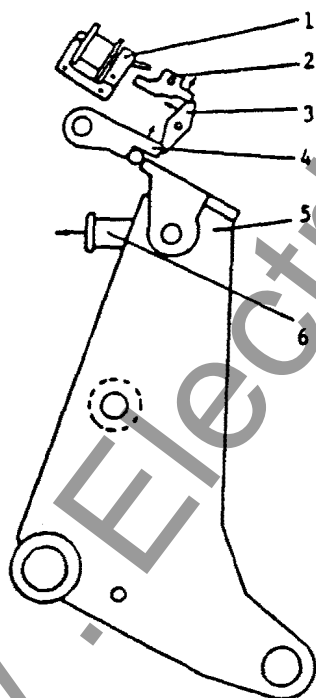

Figure G Operating device BLG 1002

G-1	Trip magnet
G-2	Auxiliary opening catch
G-3	Intermediate catch
G-4	Main opening catch
G-5	Operating arm
G-6	Coupling piece

Lift up the spring loaded auxiliary opening catch G-2 and press in the intermediate catch G-3. The main catch G-4 can then be lifted up and the operating arm G-5 can be moved in the direction of the arrow towards the open position.

Tripping device

All the tripping devices are adjusted and delivered with the correct prestressing.

Pressurizing, preparation

As the circuit-breaker pole is delivered vacuum processed and filled with SF6 gas to the pressure 18 PSI abs (68°F), only a filling of SF6 gas up to the filling pressure given on the rating plate is required, at taking into service.

It is appropriate to carry out pressurizing directly from an SF6 gas bottle with the help of accessories, as described in figure H. In order to avoid risks at the first filling, due to possible transport damages to the porcelain, the gas bottle with filling equipment shall be placed as far as possible from the circuit-breaker and preferably behind some protection. The hose length is 50 Ft.

At the same time operating cables shall be connected to the terminal blocks of the operating device for CLOSE and OPEN operation. The cables shall be drawn to the same protected place as the gas equipment, where they shall be connected to appropriate push button switches. The control switch of the operating device shall be set in the "Remote" position. Switch on the motor starter so that the closing springs are charged.

Gas filling with SF6

Start with circuit-breaker pole A.

1. Dismount the tightening cover H-13 from the T-coupling H-12 and mount one of the density switches H-14 of the circuit-breaker, which accompanies the circuit-breaker, in a separate box. The clamp nut of the density switch shall be moderately tightened by hand. Dismount the tightening cover from the check valve H-11.
2. Open the main cock H-2.
3. Open the cocks H-9, H-7 and H-6 in the order they are mentioned, until a faint hiss is heard in the opening of the hose.
4. Let the weak stream of gas flow through the hose during approximately 3 minutes, so that the hose is completely filled with dry gas.

5. Close the cock H-9 and connect the hose to pole A by means of pressing the nipple H-10 into the check valve H-11 and threading on the clamp nut fully. Only a light tightening of the clamp nut is necessary.
6. Open the cock H-9 and go to a protected place.

The pressure is regulated by means of the reducing cock H-6 and shall be read on the density switch H-14.

Note that, due to the pressure drop in the hose, the density switch shows a higher pressure than that prevailing in the pole as long as filling is in progress. In order to check the actual pressure in the pole the supply cock H-7 shall be closed until the gas flow ceases, and then reading can be carried out.

7. When the pole has been filled to the filling pressure given on the rating plate the cock H-7 shall be closed. At reading the density switch the correct pressure will be obtained, i.e. compensated to 68°F regardless of the temperature prevailing at the time of filling. At reading the manometer H-5 or another normal manometer the filling pressure shall be corrected in relation to the temperature, in accordance with Table I.
8. Operate the circuit-breaker three times CLOSE and OPEN, from a protected place.
9. Go to the pole, close the cock H-9, disconnect the hose from the check valve H-11 and mount a density switch. Check that the density switch shows a pressure equal to the filling pressure stated on the rating plate. If such is not the case the density switch shall be disconnected for an adjustment.
10. For poles B and C the filling procedure described in points 5-9 above shall be repeated.

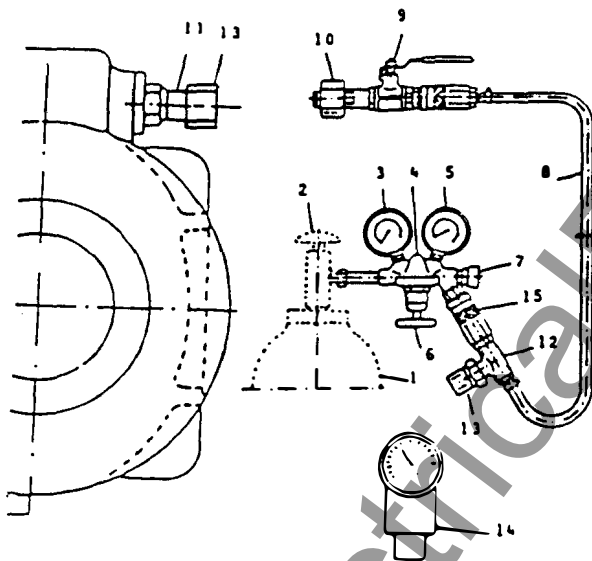

Figure H Gas filling equipment
 article no. 560C088-01

H-1	Gas bottle SF6
H-2	Main cock
H-3	Manometer (high pressure)
H-4	Reducing valve
H-5	Manometer (low pressure)
H-6	Reducing cock
H-7	Supply cock
H-8	Hose L=50 FT.
H-9	Cock
H-10	Nipple with clamp nut
H-11	Check valve
H-12	T-coupling
H-13	Tightening cover
H-14	Density switch (forms part of the circuit-breaker poles)

Pressure values for SF6 gas filling

Different gas pressures can occur, depending on different requirements concerning the lowest ambient temperature. The filling pressure applicable to the circuit-breaker is given on the rating plate.

Table I

Filling pressure in PSI (abs) at 68°F given on the rating plate	72.5
Filling pressure in PSI overpressure read on K-5	
Temp at gas filling, °F	
104	63.8
86	60.9
68	58.0
50	55.1
32	52.2
14	49.3
-4	46.4
-22	43.5

For every filling pressure there are established signal - and interlocking pressures at which the contacts in the density switches close (at a pressure drop). The existing pressure limits at 68°F are given in Table II.

Table II

Filling pressure	PSI (abs)	72.5
Signal pressure	"	65.0
Interlocking pressure C and O	"	62.0
Lowest temperature	°F	-40

Mounting of density switches

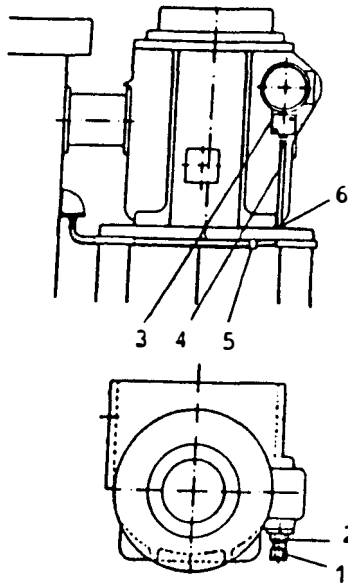

Figure K

K-1	Tightening cover (for transport only-sahll be kept for overhauls)
K-2	Check valve
K-3	Density switch
K-4	Cable
K-5	Cable clamp
K-6	Tightening sleeve

The greatest possible cleanliness shall be observed at mounting of the density switches. The clamp nuts shall be tightened with 7.5Ft.-lb.

Mount the cable K-4 between the operating device and the density switch. Fasten the cable under the plate at the top of the framework.

Tightness Check

After mounting has been completed a rough check shall be made with soapy water or sniffer around the connections of the density switches.

The density switches shall be read after one month, and afterwards annually.

Electrical joint compound

High voltage conductors consisting of aluminium bars or aluminium holders for wires can, after being treated with electrical joint compound, be directly connected to the terminal plates of the breaking units, which are of aluminium.

If, on the other hand, copper bars or copper holders for wires are used, bimetallic washers must be mounted in the joint. Bimetallic washers can, on request, be delivered by ASEA Brown Boveri.

Treatment with electrical joint compound shall be carried out in the following way:

1. The contact surfaces shall be cleaned from grease and old joint compound.
2. The surfaces shall be brushed with a clean steel brush or polished with an emery cloth.
3. Immediately afterwards the following shall be carried out:
 - Aluminium surfaces shall be coated with electrical joint compound article number 1269 0012-202.
 - Copper surfaces shall be coated with electrical joint compound article number 1269 0012-201.

The compound shall be stirred before being applied so that metal grains are evenly distributed.

4. The joint shall be mounted together with the electrical joint compound still there.
5. Any superfluous joint compound shall be wiped off.

NOTE: Bimetallic washers shall be placed so that their aluminium sides are turned towards aluminium surfaces and their copper sides towards copper surfaces or silver-plated ones.

Electrical joint compound shall only be used in fixed joints and shall not be used inside the breaking units.

Check prior to taking into service

Before taking the circuit-breaker into service the following should be carried out:

1. Check that the circuit-breaker and the operating device have been mounted according to the instructions in question.
2. Check that all bolted joints involved in the mounting are tightened.
3. Check that all the poles are in the correct open position. The hole F-8 shall be opposite the corresponding hole in the mechanism housing F-14.
4. Check that the lock nuts in the rod system are tightened.
5. Check that the screws in the terminal blocks which have been involved in the mounting are tightened.
6. Check that no transport damages have occurred to the operating device.

7. Make a visual check that the oil dashpot has not leaked oil into the operating device.
8. Place auxiliary tools, crank, bolts and pins in their holders in the operating device.
9. Connect the operating device for remote operation from a protected place in connection with gas filling and trial operation. The control switches shall be in the "Remote" position.
10. Connect the gas filling equipment for filling from a protected place.
11. Fill in gas pole by pole and trial operate three times in a protected position in accordance with the instructions.
12. Check the function values of the circuit-breaker:

Closing time		ms
Opening time coil I		ms
Opening time coil II		ms
C-0 time		ms
Check of the lowest operating voltage		
Opening coil I		V
Opening coil II		V
Closing coils I and II		V
Check of electric heater element		
Check of setting of the thermostat		
Check:		
Filling pressure		PSI abs
Alarm level (setting of the indicator)		PSI abs
Interlocking level (setting of the indicator)		PSI abs

13. Take the circuit-breaker into service.

MAINTENANCE INSTRUCTION FOR HPL-BREAKERS

In this instruction recommendations are given for service, care and maintenance of outdoor circuit-breakers of type HPL with SF6-gas as extinguishing medium.

Table of contents

GENERAL INSTRUCTIONS FOR RUNNING MAINTENANCE	Page 2
Storage of breaker components before erection	2
Inspection and maintenance of breakers	2
Inspection interval	2
Life of the breaker	3
Life of the contacts	4
Tightness check	4
External cleaning	4
Lubrication	5
Rust protection	5
GENERAL DIRECTIONS FOR REVISION	6
Security precautions	6
Necessary equipment	7
Premises	8
Emptying of gas	8
Treatment of contact surfaces	9
Protection of cleaned parts	9
Treatment of gaskets and sealing surfaces	10
Gas filling	11
Inspection before putting into operation	12

www.ElectricalPartManuals.com

GENERAL INSTRUCTIONS FOR RUNNING MAINTENANCE

Storage of breaker components before erection

Breakers intended for outdoor operation are generally delivered in units which are determined by means of transport. Before erection, these units shall be stored indoors or under a roof as long as possible. If the units will be stored outdoor, they must be blocked up to prevent them from standing in water pools. With outdoor storage under long time, the units shall be covered with tarpaulin and the heating elements of the operating mechanism and control cabinet shall be connected.

Inspection and service of breakers

In order to maintain a good function during a long time, the breaker shall be inspected at regular intervals and if necessary be cleaned, lubricated and revised.

As the operating conditions - operating rate, breaking current, climate - can vary for various breakers, it is difficult to give definite directions about inspection interval and the extent of the maintenance.

The given intervals are therefore recommended guiding values, provided that the shorter time is valid for breakers operating under hard conditions, in a tropical climate or in a strongly humid alt. polluted atmosphere and the long time is valid for breakers operating under light conditions and in a mild climate.

The user can, by means of the result during the inspection, decide if the intervals can be longer or has to be shortened.

Inspection interval

<u>Interval</u>	<u>Measures in connection with inspection</u>
-----------------	---

1-2 years	A) Visual examination of the condition of the breaker together with a check of the gas pressure, insulators, operating mechanisms and heating elements.
-----------	---

If necessary lubrication and cleaning.

The breaker is trial operated a few times.

Remarks:

With the first inspection, the bolted joints on the breaker and operating mechanism shall be tightened up. All the wiring joints in the terminal blocks of the operating mechanism shall be retightened. It is not necessary to repeat this tightening, only after bigger overhauls.

6-8 years B) The measures as mentioned under A and besides:
Removal of inspection locks in order that all the mechanism parts are accessible for cleaning, rust protection and lubrication.

Oil level check in the dashpots. If necessary touch-up painting. A check that the functional values of the breaker still are within the limits.

12-16 years C) The measures mentioned under A & B and besides:

An exchange of the worn parts in the operating system and operating mechanism.

Alternative inspection according to point C after 2000 operations.

Life of the breaker

On the condition that the recommended inspection intervals and measures are maintained, the life of an HPL breaker will be very long.

Next point that secure a long life can be named:

- 1) The burning off of the arcing contacts is small.
- 2) Every breaking element is supplied with drying agent that at least meets the life of the breaker.
- 3) The bearings in the gas filled space are maintenance free.
- 4) The sealings are achieved by double O-rings

The first cause to open a breaking element is with suspicion of heavy burnt arcing contacts ascertained leakage or ascertained mechanical failure.

Opening of a breaking element requires special precautions and shall only be done by a qualified mechanic.

Life of the contacts

The subjoined diagram shows the number of interruptions as function of the breaking current that the contacts of an HPL-breaker can manage before the burning becomes that heavy that they will have to be changed.

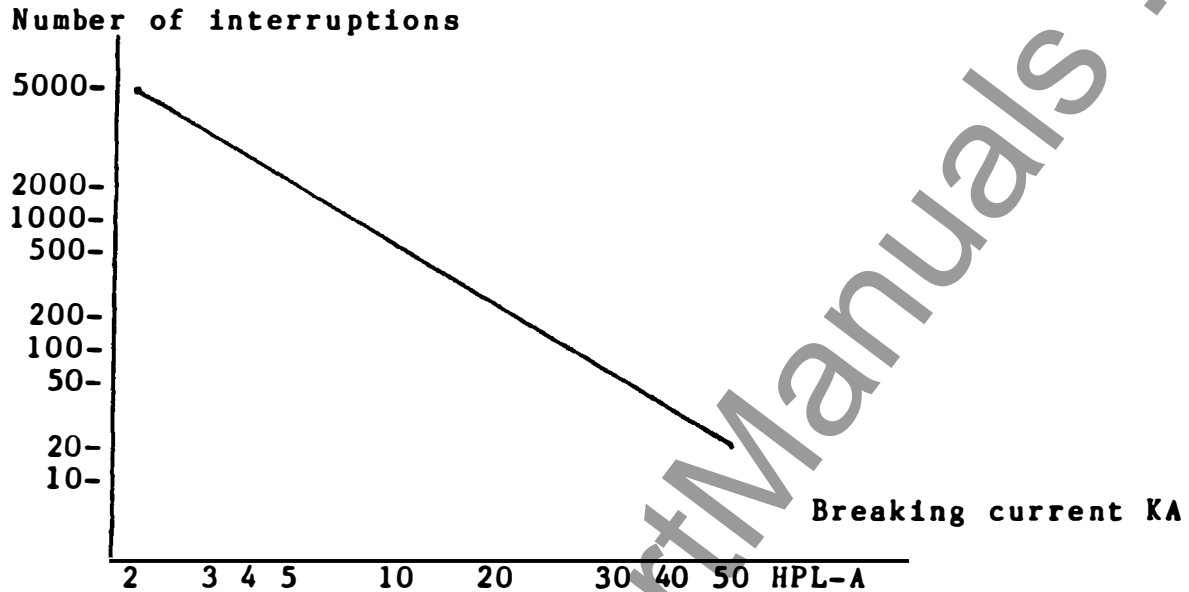

Number of interruptions between two revisions at different breaking current levels.

Ex: The breaker manages 20 interruptions at 40 KA breaking current.

Tightness check

The breakers are provided with density monitor switches (=temperature compensated pressure gauges).

Every density monitor switch is provided with an alarm contact which gives an electrical signal if abnormal leakage should appear.

A new or a revised breaker should be tightness checked by means of reading the density monitors after approximately 1 month and afterwards with a 1-2 years interval.

External cleaning

The insulators of the breaker shall be cleaned from salt and dirt depositions together with the cleaning of the other insulators in the substation. The time interval for this cleaning will be fixed by the polluting atmosphere.

All the HPL breakers are "wash-proof" that is to say that the breakers can be cleaned by means of rinsing with water without moisture penetrating into the breaker and damaging vital parts.

Lubrication

For lubrication, the lubricants recommended in manual shall primarily be used. This is especially important in cold climates with temperatures below -13°F .

The bearings of the breaker and operating mechanism are lubricated with grease G and they normally do not need lubrication before the larger revisions. Plain bearings in mechanism details as arms, links and link gears are lubricated with grease G at delivery and assembly. These bearings shall be regularly lubricated with a few drops of oil B. For the lubrication of O-ring sealings see: "Treatment of sealings and sealing surfaces". The teeth in the gear shall be lubricated with grease G, that will be painted on in a thin layer.

Note: During the lubrication of the operating mechanism great care must be taken that no grease or oil can penetrate into the sliding clutch.

The dashpots are at delivery filled with oil D.

The closing dashpots in the newer operating mechanisms are filled with oil S (Silicone oil). On these dashpots, the cover is stamped "S".

Rust protections

Some parts of the mechanism in the operating mechanism are made of steel and are surface treated by means of manganese phosphatizing and rust protected by dipping in oil. This applies for catches, gear wheels and details in the link gear. The big closing - and opening springs are rust protected by painting with two component paint. Besides, before delivery a thin layer of rust protecting grease is sprayed over the mechanism of the operating mechanism. In spite of the good rust protection minor corrosion will occur after some years, especially when the breaker is standing in strong corrosive surroundings. The rust stains shall be removed and new rust protection shall be painted or sprayed on. As rust protection grease G or Tectyl 506 (art. no. 1241 0011-108) is recommended.

Note:

Tectyl 506 develops after drying a waxlike protection film and may not be sprayed into the bearings and catch mechanisms or onto gear wheels and chains. During a rust protection treatment the sliding clutch in the operating mechanism shall be protected against penetration of rust protective means.

GENERAL DIRECTIONS FOR REVISION

When the contacts have been subjected to the maximum allowable electrical stress (see "life of the contacts"), the breaker shall be revised - that is to say dismantling, cleaning and change of contacts.

For intervention in the breaker with for example revision and repair work the following general directions are given:

Security precautions

Close down of the breaker for revision

- 1) Put the breaker in the open position.
- 2) Disconnect and earth the high voltage side.
- 3) Discharge the closing and opening springs by means of the interruption of the motor current and doing a close open operation.
- 4) Interrupt the operating current and if needed even the heating current.

Emptying of gas

Work on the insulators of the breaker or live parts as well as transport and dismantling of complete breaking poles from the frames may not be done before the breaker is emptied till a maximum pressure of 18 PSI abs. For the opening of a normal pressurized volume - for example a breaking element, the volume shall be emptied completely till atmospheric pressure. See under clause "emptying of gas" (page 8).

If the gas of a breaker, that has been in operation and has been breaking current, will be emptied into the free air, this shall be done through a dust and absorption filter. Emptying shall be done outdoor and on ground level. This is also applicable to nitrogen in the case that nitrogen has been used for internal cleaning of the breaker that will be revised.

Cleaning and waste disposal

The decomposition products which are formed in the breaking elements are in combination with humidity corrosive and can cause skin- eye- and mucous membrane irritation. With the opening and internal cleaning of the breaker, a close fitted dust mask with a filter against fine dust and acid gases, protective plastic or rubber gloves and a long sleeved overall shall be used.

The dust (decomposition products), that is formed in the breaker, shall be sucked up with a vacuum cleaner provided with a dust filter and wiped off with a cloth that is sprinkled with trichloroethane or toluol.

All the dust as well as the used absorption agent is stored in a sealed container and is disposed of as chemical waste according to the valid provisions. During waste disposal and handling with decomposition products, it is necessary to wear protective gloves.

Drying cloths, protective gloves and vacuum cleaner bags shall be rinsed carefully with plenty of water.

Filling with gas

Due to eventual transport damage on the insulators, the gas filling and trial operation of a circuit-breaker that has been dismantled for revision or transport shall be done from a protected place or at a distance of at least 50 Ft. ♦

Environmental aspects

Unused SF6 gas is non poisonous, non smelling and colorless. It is heavier than air and with substantial outflow it gathers easy in low situated spaces like cable trenches, tanks and such.

With large amounts of SF6 in these spaces, there is a risk of suffocation due to lack of oxygen.

Necessary equipment

In order to be able to do the revision in the shortest possible time, it is necessary that all the equipment and the replacement parts are available before the start of the work.

Tools:

A normal tool kit with torque wrenches (7.5-220 Ft-lb)

Lifting equipment and slings.

Special tools as prescribed in the overhaul instructions of the breaker.

Gas treatment equipment for evacuating, cleaning, compression and storage of used SF6 gas together with instruments for pressure and vacuum monitoring.

Personal security equipment

Close fitting dust mask

Long sleeved overall

Protective plastic or rubber gloves.

Cleaning equipment

Vacuum cleaner with plastic mouthpiece and fine dust filter.

Steel brush for copper and aluminium contact surfaces.

Trichloroethane or Toluol for the cleaning of internal surfaces.

Acetone for the removal of traces of glue

Lint free rags.

Strong plastic foil and plastic bags to prevent penetration of moisture and to protect cleaned parts until the assembly.

A storage container for disposal products and used absorption filters.

Spare parts

Sets of contacts, gaskets, absorbent container, glue, lubricant, anti corrosive agent. SF6 gas and Nitrogen.

Test equipment

Recording drum or oscillograph for the registration of damping curves of the operating mechanisms.

Measuring device for functional times and resistance.

Sniffer or soap water for tightness check.

Premises

Opening of breakers or breaking elements shall be done indoors in a dry and clean surrounding.

Providing the weather is stable and gives indoor-like working conditions, the breaking elements can be dismantled outdoor, transported to and revised in a smaller workshop.

With the larger HPL-breakers, that are provided with a gas tight joint between breaking element and post insulators, it is possible to dismount the breaking element only for revision. This shall not be done under rainy conditions.

A breaking element shall under no condition be opened during rain or unstable weather, not even when the air humidity is 80% or higher.

Emptying of gas

The breaker is evacuated by means of the gas treatment equipment, that purifies and compresses the gas, so that it can be reapplied.

After the evacuation, the breaker is filled with nitrogen up to atmospheric pressure after this evacuated again. In this way the eventual free drifting dust in the breaker is removed.

Finally the breaker is filled again with dry nitrogen up till atmospheric pressure after which it is ready for dismantling and transport till the workshop.

NOTE

If work on the circuit-breaker only affects the outside of the breaker, for example cleaning of the insulators, it is sufficient to empty the breaker down to a pressure of 18 PSI abs. After the work is done, the breaker is refilled up to the normal working pressure.

Treatment of contact surfaces

When the breaking elements are dismantled, the contacts shall be treated according to the following directions.

Silvered contact surfaces

Silvered contact surfaces shall be cleaned, if necessary, with a soft cloth and solvent (trichloroethane). Steelbrushing or grinding is not allowed.

Copper surfaces

Copper surfaces shall be clean and oxide free. If necessary, they shall be cleaned with cloth and solvent (trichloroethane) or steel brushing. After steel brushing, the surface shall always be cleaned from loose particles and dust.

Aluminium surfaces

Aluminium contact surfaces shall be cleaned with steel brush or emery cloth. Directly afterwards the surface is very thoroughly cleaned from particles and dust with a dry cloth. After this, a thin layer of vaseline is applied. This shall be done withing 5 minutes after the cleaning. The joint shall be assembled within 15 minutes.

Moving contact surfaces

Silvered: Cleaned, if necessary, with soft cloth and solvent (trichloroethane). No steel brushing.

Non silvered: Cleaned as silvered surfaces, can be steel brushed. After steel brushing they shall be thoroughly cleaned from loose particles and dust.

Lubrication: Lubricant - Grease K according to information 051L05103 - is applied in a very thin layer on the surfaces of the male contact and the puffer cylinder. The superfluous grease is carefully removed.

Protection of cleaned parts

If the circuit-breaker is not assembled directly after the cleaning of the included parts, they shall be protected against contamination by storage in plastic bags. The insulators shall be protected by a strong plastic film, which is fastened over both ends.

Treatment of gaskets and sealing surfaces

With reassembly of the breaker, all the gaskets shall be replaced by new ones.

General

O-ring grooves in this type of breaker are less deep than normal standard.

Sealing surfaces and O-rings shall be sparsely greased to accomplish a better sealing against this surface and at the same time protecting it against corrosion. Superfluous grease that can penetrate into the breaker may not appear.

The surfaces of the flanges outside the outer O-ring are coated with corrosion preventing agent, adapted to the actual material of the flange.

Material for de-greasing and cleaning:
Trichloroethane art. no. 1177 1016-611.

Material for greasing of O-rings and nitrite rubber in static sealings;
Grease G, see information 051L05103

Material for greasing of O-rings and nitrite rubber in moving sealings:
Grease G, see information 051L05103

O-rings of EPDM rubber (normally not used in HPL) shall be greased with grease G.

Material for the solution of contact glue:

Acetone, art. no. 1014-401

Material for rust protection of untreated or phosphatized steel:
Valvoline Tectyl 506, Art. No. 1241 0011-108

Cleaning and checking

Together with the assembly all the sealing surfaces shall be cleaned, degreased and checked. O-ring grooves are not allowed to have transverse scratches. Potential small scratches in the sealing surfaces can be removed with fine emery cloth. Polishing shall be done in the direction of the sealing line and never across.

Assembly of static and moving sealings

Clean and check the surfaces. No scratches or other surface damages may be found across the sealing line and with axial movement no scratches or other surface damages may be found across the direction of the movement. O-rings are carefully greased with grease G.

Gas filling

After that the breaker has been re-erected, after revision or repair, it shall - before trial operation - be filled with SF₆-gas. See the valid erection manual.

Evacuate till a pressure of 1 mbar and continue with pumping at least 1 hour from the moment the pressure of 1 mbar is reached.

Break off the evacuation and fill the breaker with dry, clean nitrogen up till atmospheric pressure. Leave the breaker alone for a few hours.

Evacuate again till a pressure of 1 mbar and fill the breaker with clean SF₆ gas up till the normal working pressure.

Observe the security precautions for gas filling.

NOTE:

Before filling the filling hose shall be carefully cleaned from contamination and humidity by allowing a weak nitrogen or SF₆-gas stream to flow through the hose for at least 3 minutes.

Filling hoses shall be stored such, that they are not exposed to humidity and contamination. They shall not be used for other purposes.

Inspection before putting into operation

Tighten all the screw and bolt joints and terminal blocks that have been affected during the revision.

Close and open the breaker slowly by hand-cranking the operating mechanism (see instruction for the operating mechanism). Check during this operation that the link system moves correctly and that the mechanism is correctly adjusted in the open position.

Operate the breaker about 10 times where the first three operations shall be done from a sheltered place or at a distance of at least 50 Ft. from the breaker.

The tightness is checked using a so-called "sniffer" or soap water around all the flanges and covers that have been disassembled.

The breaker shall meet the valid functional values without large deviations.

www.ElectricalPartManuals.com

INSTRUCTIONS FOR OVERHAUL

FOR SF6 CIRCUIT-BREAKERS TYPE HPL 362-550/25B2-31B2

AND CAPACITOR SWITCH TYPE HPL 145-245/245-550/25B1-31B1

LIST OF CONTENTS

General	Page 2
Dismounting of breaking unit	4
Dismantling of breaking unit	6
Changing of contacts	10
Upper current collector	10
Lower current collector	11
Puffer	12
Upper mechanism	14
Mounting of breaking unit	16
Renovation of support insulator with lower mechanism housing and tripping device	18
Dismounting of support insulator	18
Tripping device	20
Renovation of support insulator	22
Renovation of mechanism	24
Mounting after renovation	25
Erection of circuit-breaker and start-up test	25

www.ElectricalPartManuals.com

General

HPL-B circuit-breaker for higher voltages than 245 kv and HPL-B circuit-breakers with extra high insulation to earth - for example some types of capacitor switch - are, for reasons of conveying technique, usually delivered with the breaking unit dismantled.

The breaking units and support insulators have been filled with gas prior to transport, and in order to make such transport possible, the joint between these components is of special gas-tight construction. Owing to this gas-tightening the breaking units need only be dismantled for inspection at an overhaul.

Figure A shows some examples of HPL-B circuit-breakers with gas-tight transport joints between the breaking units and the support insulators.

Before the circuit-breaker is dismantled, and while work is in progress, our maintenance instructions 5409 719E-1 should be read through and followed.

We wish to draw special attention to the applicable safety and gas handling regulations.

Prior to dismantling, the function values of the circuit-breaker should be checked and recorded. Considerable deviations from the recommended values indicate that something must be checked with special care at future overhauls.



I HPL 145-245/245-550/25B1-31B1
Capacitor switch

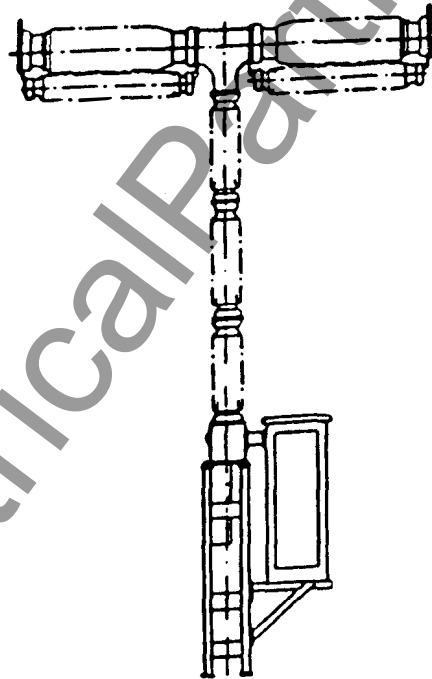

II HPL 362-550/25B2-31B2

Figure A

Different variants of the HPL circuit-breaker with gas-tight transport joints under the breaking units.

Dismounting of breaking unit

The parts named in these instructions:

Disc B-4
Screw B-5
Guide B-6
Lock washer B-8
Transport cover C-3
Transport cover C-7

As well as the necessary screws and O-rings accompany the circuit-breaker on delivery from ASEA Brown Boveri and should, accordingly, be taken care of at assembly of the circuit-breaker, so that they can be used at future overhauls.

Working procedure:

1. Disconnect the circuit-breaker and empty out the gas in accordance with instructions in 051L05105.
2. Crank the operating device slowly towards the closed position until the dimension $L = 5.4''$ for the operating arm B-2 in the mechanism housing B-1 is obtained.

The way in which slow operation is carried out is described in the instructions for the operating device.

3. Block the mechanism in this position by means of mounting the disc B-4 under the tripping device B-3 and screwing in the screw B-5 with the guide B-6 against the lower end of the pull rod in the tripping device.
4. Dismount the cover B-7 from the mechanism housing under the breaking units - the figure shows a T-breaking unit, but there is also a similar cover on the flange under a vertical breaking unit.
5. Mount the lock washer B-8, which shall keep the contacts in the breaking units in the correct position.
6. Remove the retaining ring B-9 and the pin B-10.
7. Prepare for lifting the breaking unit by means of mounting the lifting strap B-11 on the T-breaking unit according to figure B or placing a lifting strap around the upper part of the vertical unit.
8. Loosen the mounting screws B-12 from the support insulator and lift the breaking unit up with care.

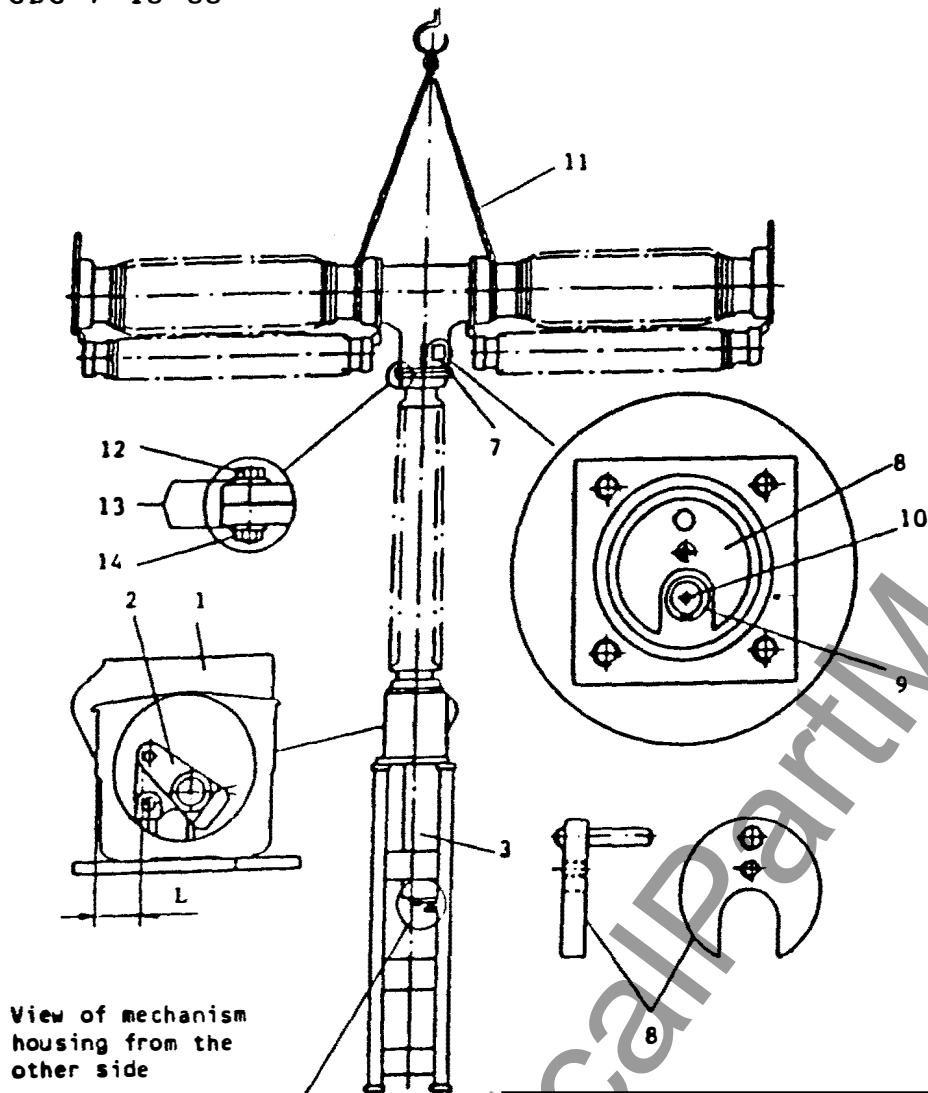

Figure B Dismounting of breaking unit

B-1	Mechanism housing
B-2	Operating arm
B-3	Tripping device
B-4	Disc
B-5	Screw M16 x 80
B-6	Guide
B-7	Cover with two O-rings 64.5 x 3
B-8	Lock washer
B-9	Retaining ring
B-10	Pin
B-11	Lifting strap
B-12	Screw M12 x 50
B-13	Washer 13 x 24 x 2
B-14	Nut M12

9. As soon as possible, mount the cover C-11, the transport cover C-3 and the transport cover C-7 with respective O-rings.
10. Place the T-breaking unit on an appropriate transport base - Figure D - so that it cannot tip over during transport.

Vertical single units can be carefully laid down and transported in a horizontal position, in which case they should be placed on rubber or cellular plastic so that the insulators are not damaged.
11. Fill SF6 or nitrogen gas into the support insulators with mechanism housing to a pressure of 18 PSI abs.
12. Transport the breaking units to the factory for overhaul.

Dismantling of breaking unit

Dismantling and mounting will be greatly facilitated by placing the unit on a mounting device E-2 with mechanism for operating the contacts. The device fits both the T-unit and the vertical unit.

In order to prevent moisture in the air from coming into prolonged contact with the dust in the breaking units the work of dismantling and cleaning shall be planned so that it can be carried out quickly and without long interruptions.

During cleaning, overalls and protective gloves shall be worn. At opening of the breaking unit, and if the dust rises, a protective mask shall also be worn.

As the breaking unit is gradually opened the powder - like waste products in the unit shall be taken care of - first with a vacuum cleaner and then by means of thorough cleaning of dismantled parts. It is particularly important that all sealing surfaces shall be carefully cleaned. Cloths moistened with toluol spirits or trichlorethane shall be used for cleaning.

If the overhaul work takes a long time - more than one day - cleaned parts shall be protected from dust by being packed in plastic bags. Insulators shall, after internal cleaning, be protected by means of fastening plastic film over the ends.

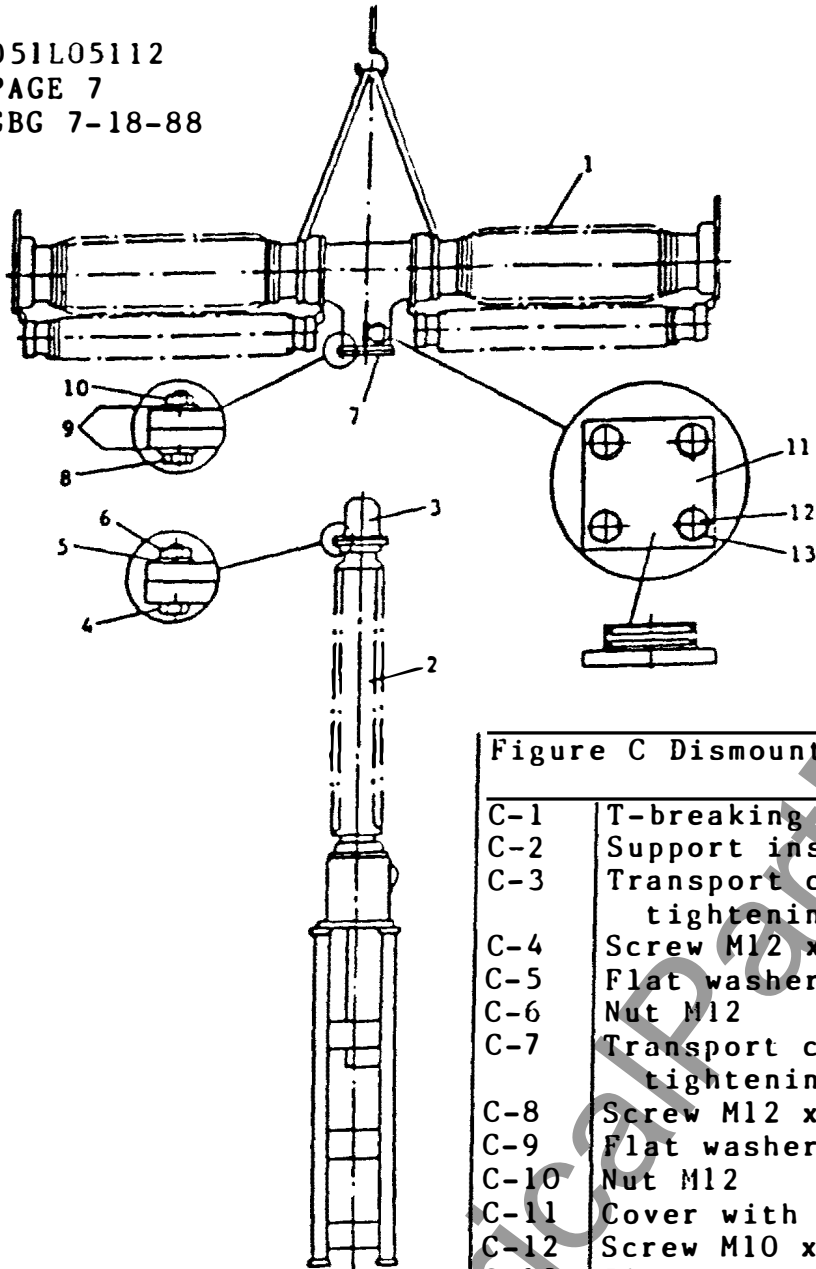

Figure C Dismounting of breaking unit	
C-1	T-breaking unit
C-2	Support insulator unit
C-3	Transport cover with O-rings-tightening 180 x 5.7
C-4	Screw M12 x 60
C-5	Flat washer 13 x 24 x 2
C-6	Nut M12
C-7	Transport cover with O-rings-tightening 170 x 5.7
C-8	Screw M12 x 50
C-9	Flat washers 13 x 24 x 2
C-10	Nut M12
C-11	Cover with two O-rings 64.5 x 3
C-12	Screw M10 x 25
C-13	Flat washer 10.5 x 22 x 2

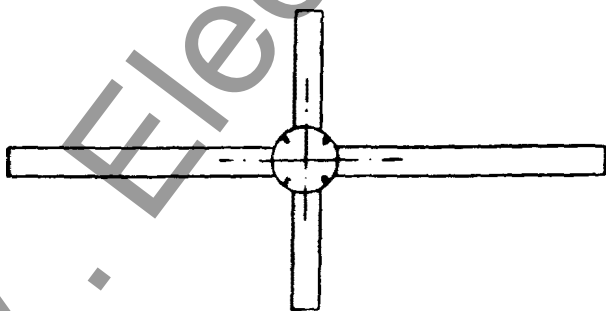

Figure D
 Transport base article No.
 5439 142-M

Working Procedure:

1. Remove the transport cover C-7 but let the O-rings-tightening remain. Mount the breaking unit on the base E-1 and the mounting device E-2 and connect the mechanism in the device E-2 with the breaking unit by means of dismantling the cover E-11 and mounting the pin B-10 with the retaining ring B-9 and pulling out the lock washer B-8.
2. Dismount the capacitors E-3, if any.
3. Dismount the top cover E-5 and lift out the desiccants container E-6 which shall be placed in an appropriate receptacle for chemical waste.
4. Dismount the upper current collector E-7 with the upper terminal flange.
5. Dismount the breaking unit insulator. The insulator of the vertical breaking unit shall be carefully lifted straight upwards with the help of a lifting strap applied under the top flange of the insulator. The insulator on the T-breaking unit shall be slung as shown in the figure and carefully lifted obliquely upwards so that the puffer and the lower current collector E-8-9 are not damaged.

Dismounting - and in particular remounting, will be facilitated if three adjustment clamps DA-3 are first mounted on the flange of the mechanism housing E-15 - see figure DA. Fasten the clamps DA-3 with the screw DA-4 and tighten the adjusting screw DA-5 so that it barely touches the lower flange DA-2 of the breaking unit insulator. Mark the flange on the insulator so that it is put into the same place and the same position as before dismantling.
6. Dismount the lower current collector E-9

7. Operate the puffer E-8 upwards with the help of a spanner on the shaft E-13 and dismount the puffer by means of removing the pin E-10 in the lower end of the pull rod of the puffer.

The main components of the breaker pole will now be accessible for cleaning, inspection and replacement of burnt and damaged parts.

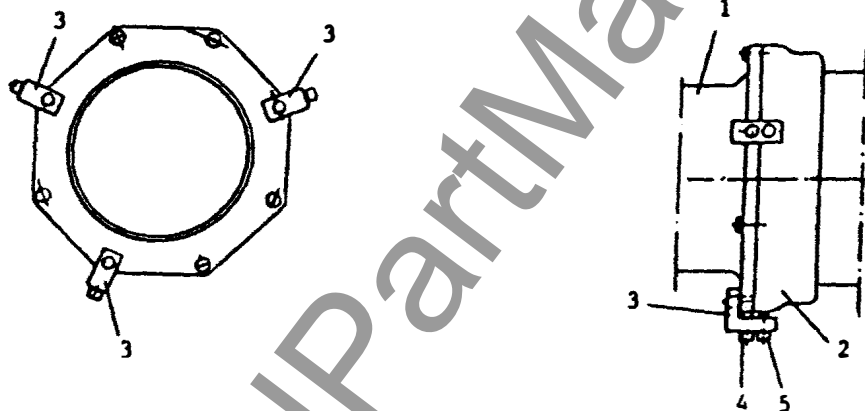

Figure DA Mounting of adjustment clamp

DA-1	Mechanism housing (E-15)
DA-2	Lower flange on the breaking unit insulator (E-4)
DA-3	Adjustment clamp article no. 5439 142-D
DA-4	Fastening screw
DA-5	Adjusting screw

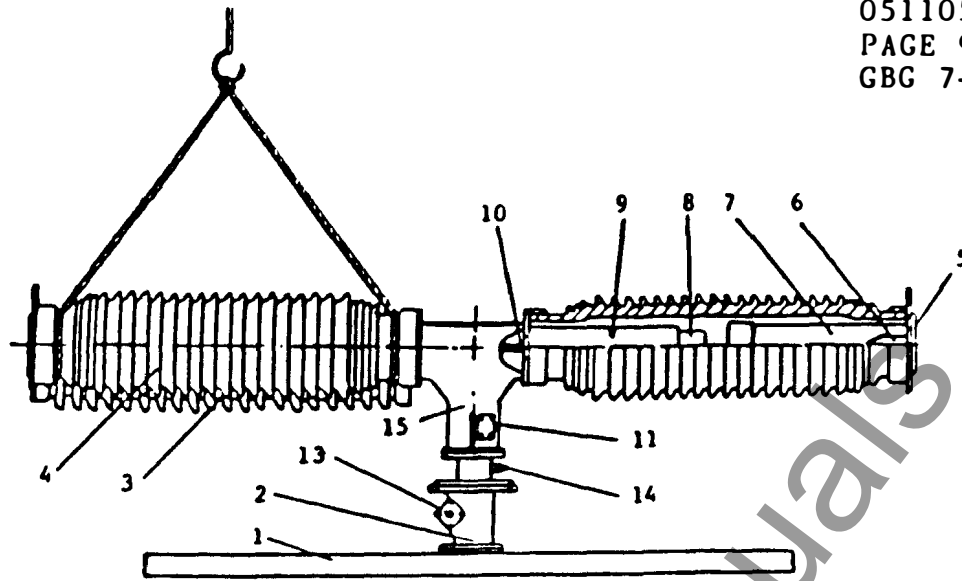

Figure E I
 T-breaking unit

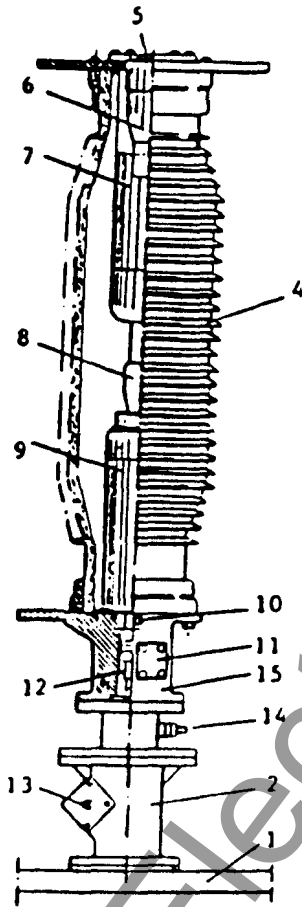

Figure E II
 Vertical single breaking element

Figure E Dismantling of breaking unit

E:I-1	Transport base article no. 5439 142-M
E:II-1	Transport base article no. 5439 142-G
E-2	Mounting device article no. 5439 142-E
E-3	Capacitor
E-4	Breaking unit insulator
E-5	Top cover
E-6	Desiccants container
E-7	Upper current collector
E-8	Puffer
E-9	Lower current collector
E-10	Pin
E-11	Cover
E-12	Pull rod
E-13	Operating shaft
E-14	Gas-filling valve
E-15	Mechanism housing

Changing of contacts

Contacts and nozzles - part F-12 + H-1-2-3-5 and -7- should be replaced when the fixed breaking contact F-12 has been burned down max 1/8" according to Figure FA II or if it has been hard burned on the outer diameter according to Figure FA III.

Upper current collector Figure F

Normally, only replacement of the fixed contact F-12 is required. For this purpose a contact spanner with catalog number LA 937 0016-1 can be used.

The new contact F-12 shall be locked after tightening, by means of upsetting material into a slot in the contact rod, with the help of a center punch.

If more careful cleaning or replacement of the contact fingers F-11 should be required, the pop-rivets F-6 (drilling diameter 9/64") should be drilled out and the cap F-8 be lifted off, and then the contact fingers can be easily dismantled. The contact surfaces shall be treated according to manual 051L05105. The surface marked with dashed lines on the fixed contact F-12 with contact rod shall be lubricated with grease K and then remounting in the reverse order can be carried out.

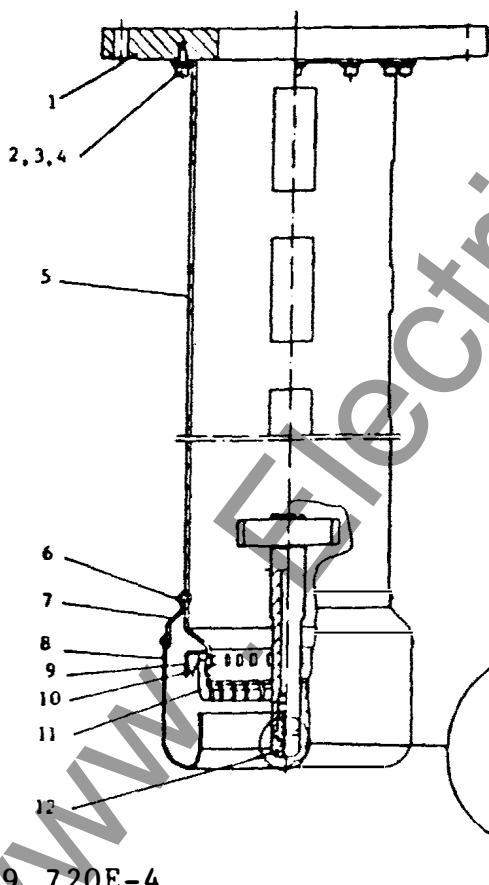

Figure F Upper current collector

F-1	Flange
F-2	Screw M8 X 20 22 Nm
F-3	Spring washer
F-4	Washer
F-5	Current collector cylinder
F-6	Pop-rivet 03.2 L=7.4
F-7	Holding ring
F-8	Cap
F-9	Support ring
F-10	Spring
F-11	Contact finger
F-12	Fixed contact 80 Nm

Shall be lubricated with grease K

Punch mark
 Sharp edges around the punch mark shall be polished off

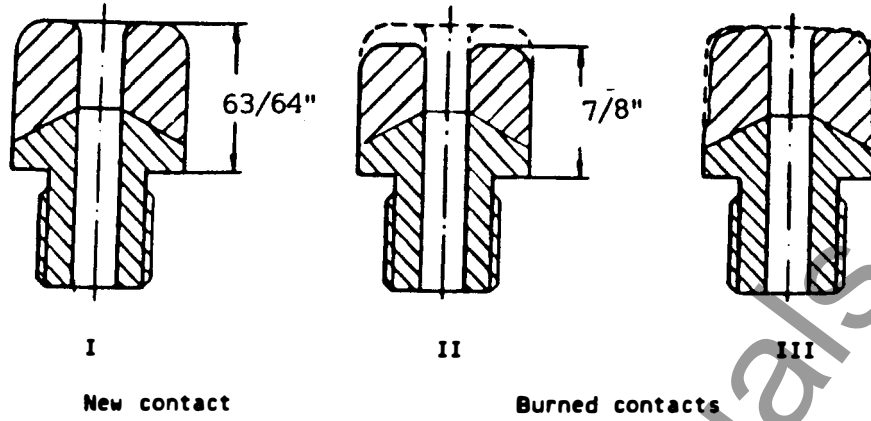

Figure FA

Lower current collector figure G

The contact fingers shall be dismantled when necessary and treated in the same way as in the upper current collector.

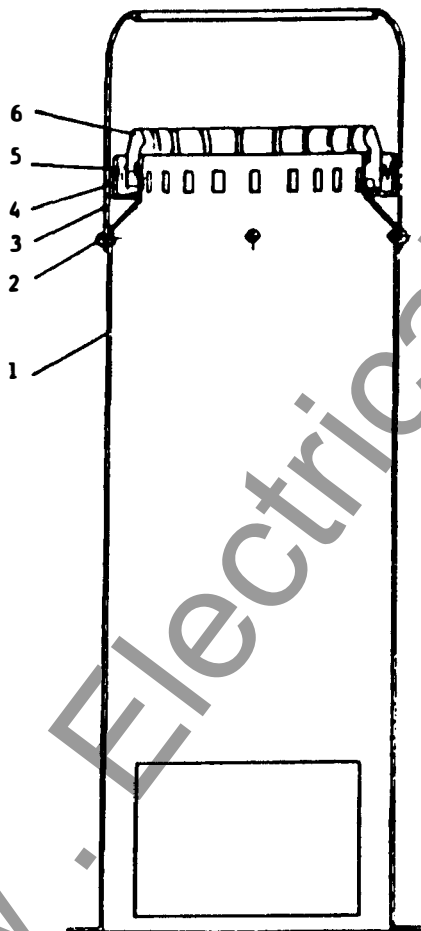

Figure G Lower current collector	
G-1	Current collector cylinder
G-2	Pop-rievet 03.2 L=7.4
G-3	Cap
G-4	Support ring
G-5	Spring
G-6	Contact finger

Puffer Figure H

Dismount the puffer by removing the screws H-8.

The old (used) nozzle shall be dismantled after being sawed off with a hacksaw along the dashed line A-A.

The following parts shall be discarded: The nozzle H-1, the sleeve H-2, the contact H-3, the springs H-5 (twelve), the pipe H-6 and the ring H-7.

These parts are included in the replacement sets which can be ordered according to the list of spare parts.

In these contact sets the new break contact is delivered, consisting of the following parts: H-3, H-5, H-6 and H-7, assembled.

The puffer shall be remounted after careful cleaning of the parts in accordance with the following:

1. The contact surfaces shall be treated according to maintenance instruction 051L05105.

The surfaces marked with dashed lines on the male contact H-4 and the puffer cylinder H-12 shall be carefully lubricated with a thin layer of grease K.

2. Place the pull rod H-12 in a vertical position - without damaging the sliding surface.
3. Place the holding ring on top of the pull rod and put the details of the contact H-3-5-6-7 on the holding ring and mount the inner screws H-8.
4. The sleeve H-2 shall be put into place over the contact H-3 - note that the sleeve shall fit against the guide pin H-10.
5. The puffer cylinder H-11 shall be put into place over the contact and the pull rod.
6. The inner nozzle H-1:2 shall be pushed into the contact H-4 and then the outer part of the nozzle, H-1:1, is pressed on H-1:2. Then the components H-1 and H-4 shall be put on top of the cylinder and the contact. Note that the contact surfaces between the normal current contact H-4 and the cylinder H-11 shall be clean and free from oxide.
7. Align the parts and screw them together with the outer screws H-8.

40 kA design

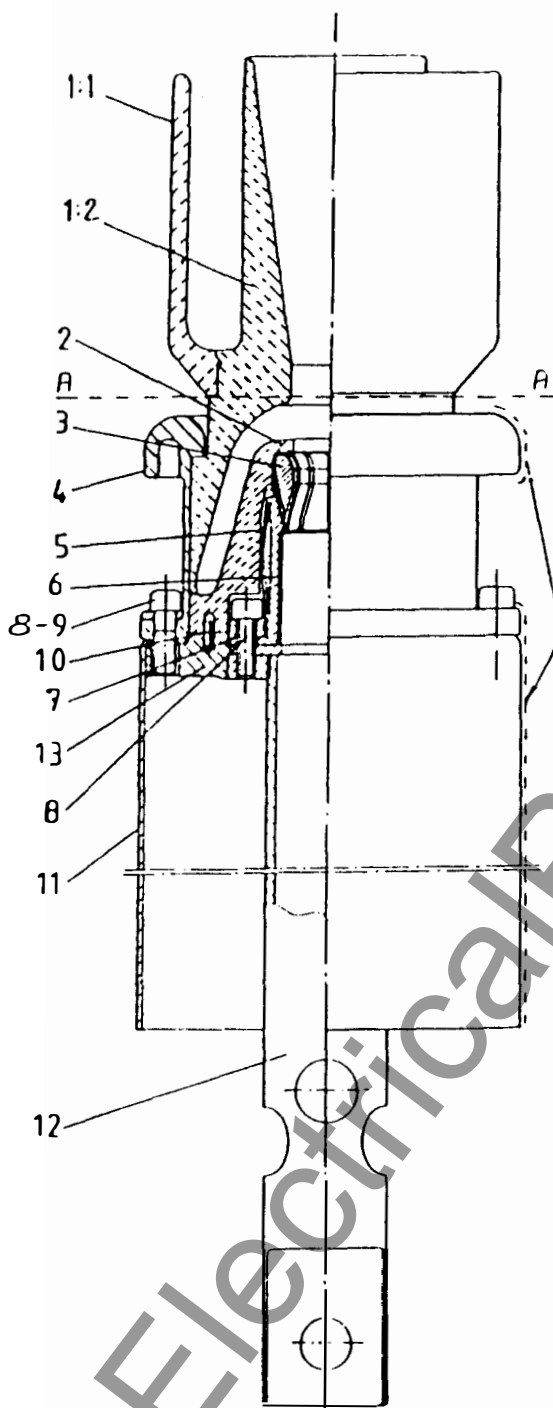
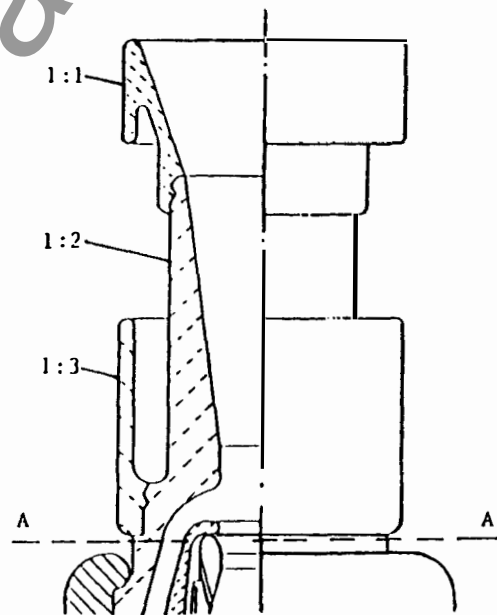

Figure II Puffer

H-1	Nozzle
H-2	Sleeve
H-3	Break contact
H-4	Normal current contact
H-5	Spring (twelve)
H-6	Pipe
H-7	Ring
H-8	Screw M8 x 30 16Ft-1b.
H-9	Washer
H-10	Guide pin
H-11	Puffer cylinder
H-12	Pull rod
H-13	Holding ring

Shall be lubricated with grease K

50 kA design



Upper mechanism

The upper mechanism with the piston J-1 for the puffer does not need to be dismantled if it is not severely polluted by waste products.

No lubrication of the mechanism is required, as all the bearing have Teflon-coated bushes.

If the mechanism is dismantled all the O-rings shall, however, be replaced by new ones, which shall be lubricated according to instructions 051L05105.

The piston J-1 shall be carefully cleaned and the O-ring J-6 and the Teflon band J-7 shall be replaced with new ones. Check that the check valve washer J-2 is level and easily movable.

The vertical single breaking unit is built on an aluminium housing which entirely lacks an inner link mechanism. The pull rod for the puffer is here directly connected with the upper part of the pull rod J-23. See also Figure E II - E-12.

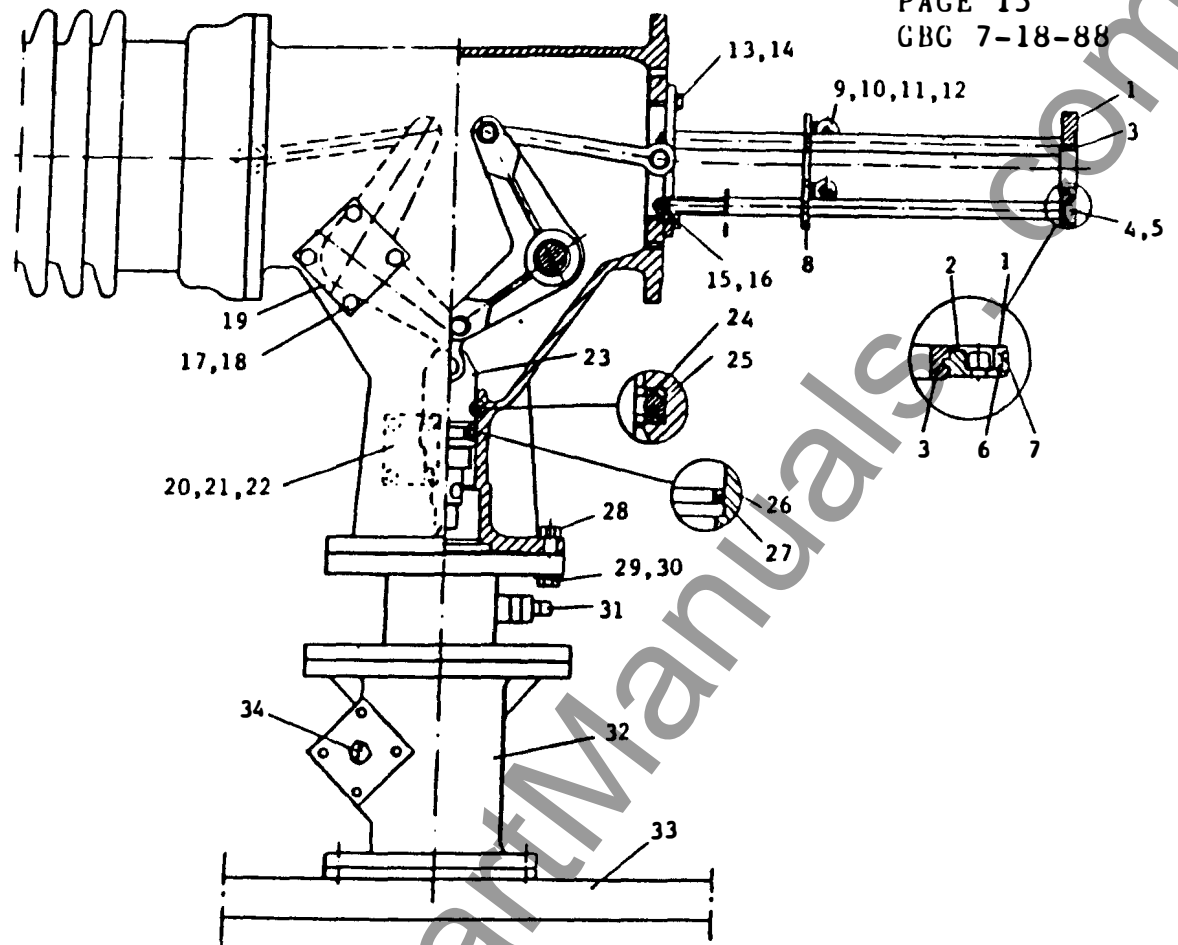

Figure J Upper mechanism

J-1	Piston	J-19	Cover with 2 O-rings 079.5 x 3, 084.5 x 3
J-2	Check valve washer	J-20	Screw M10 x 25 33Ft-1b.
J-3	Guide	J-21	Washer 10.5 x 22 x 2
J-4	Screw M8 x 25 16Ft-1b.	J-22	Cover with 2 O-rings 064.5 x 3
J-5	Spring washer	J-23	Pull rod (upper part)
J-6	O-ring 0134.5 x 3	J-24	Support ring
J-7	Teflon band	J-25	O-ring 072.6x5.5
J-8	Guide disc	J-26	Bush (Bronze/Teflon)
J-9	Roller	J-27	O-ring 059.5 x 3
J-10	Parallel pin	J-28	Screw M12 x 50
J-11	Washer	J-29	Washer 13.5 x 24 x 2
J-12	Split pin	J-30	Nut M12 55Ft-1b.
J-13	10 screws M10 x 30 33Ft-1b.	J-31	Gas filling valve
J-14	Washer 10.5 x 22 x 2	J-32	Mounting device
J-15	Nut M10 33Ft-1b	J-33	Transport base
J-16	Spring washer	J-34	Shaft with 15/16" spanner grip
J-17	Screw M12 x 30 55Ft-1b.		
J-18	Washer 13.5 x 24 x 2		

Mounting of breaking unit

1. Mount the puffer K-6. Be careful not to damage the Teflon tightening ring on the piston K-7. Connect the piston rod of the puffer and the link K-14 with the pin K-15, together.
2. Mount the lower current collector K-8 and tighten the screws K-16.
3. Place new O-rings K-10-11 on the mechanism housing K-9 and lift the breaking unit insulator K-5 carefully into place. Fasten it with the screws K-19 against the mechanism housing K-9.
4. Glue new O-rings K-10-11 under the top flange K-2 and mount it with the upper current collector K-4. Tighten the screws K-21 very lightly.
5. Operate the puffer K-6 slowly towards the closed position with the spanner K-26 and align the fixed and moving contacts so that they center against each other by means of displacing the top flange K-2 and, when necessary, the breaking unit insulator K-5 also, in the desired direction. Centering of the breaking unit insulator will be facilitated if, prior to dismounting, adjustment clamps have been mounted on the flange of the mechanism housing - see Figure DA. After adjustment, all the screws K-19 and K-21 shall be tightened.
6. After both units in a T-breaking unit have been mounted in accordance with the above, 2 packages with containers K-3 holding new activated desiccants shall be opened and the containers shall be put into place (for a single breaking unit only 1 container is required). Then the cover K-1, which has been fitted with new O-rings K-12-13, shall be mounted.
7. The cover B-7 with O-rings shall be mounted. Place the breaking unit in the almost closed position with the spanner K-26. Vacuum pump and fill the unit through the valve K-27, with SF6 gas in accordance with instructions 051L05105.
8. Check with a sniffer or soapy water that the unit is tight at all covers and insulator flanges.
9. Empty the gas until the pressure is 18PSI abs.

10. Place the unit in the tightening position by turning the shaft with the spanner K-26 so that the slot in the end of the shaft is vertical.
11. Dismount the cover B-7, the retaining ring B-9 and the pin B-10 and put in the lock washer B-8; then remount the cover B-7.
12. Mount the capacitors, if any.
13. Lift the breaking unit off the mounting device K-24. Mount the transport cover C-3 and place the unit on a transport base K-25.

The breaking unit shall now be ready for mounting on the support insulator.

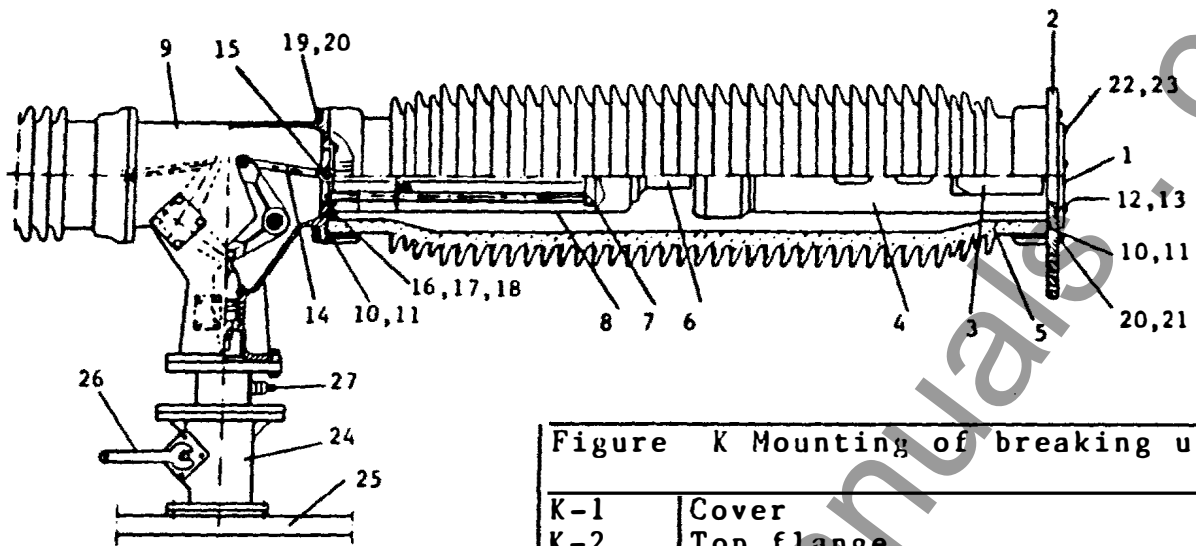

Figure K Mounting of breaking unit

K-1	Cover
K-2	Top flange
K-3	Desiccants container
K-4	Upper current collector
K-5	Breaking unit insulator
K-6	Puffer
K-7	Piston
K-8	Lower current collector
K-9	Mechanism housing
K-10	O-ring 269.3 x 5.7
K-11	O-ring 279.3 x 5.7
K-12	O-ring 159.3 x 5.7
K-13	O-ring 169.3 x 5.7
K-14	Link
K-15	Pin
K-16	Screw M8 x 20 16Ft-1b.
K-17	Washer 8.4 x 20 x 2
K-18	Spring washer
K-19	Screw M12 x 50 55Ft-1b.
K-20	Washer 13.5 x 24 x 2
K-21	Screw M12 x 60 23Ft-1b.
K-22	Screw M10 x 30 23Ft-1b.
K-23	Washer 10.5 x 22 x 2
K-24	Mounting device
K-25	Transport base
K-26	Spanner N=15/16"
K-27	Gas filling valve

Renovation of support insulator with lower mechanism housing and tripping device

Support insulators with gas-tight joints in the upper end, for transport do not normally need to be dismantled for renovation.

If, however, the breaking units are very severely polluted by waste products, opening for inspection and possibly cleaning, can be necessary.

For circuit breakers which have been in service for many years - approximately 20 years or longer - replacement of the O-rings can be advisable.

Dismounting shall normally not be carried out of doors. The entire insulator unit with mechanism housing should, therefore, be transported to the factory.

Dismounting of support insulator Figures L-M

Dismounting of the support insulator shall be carried out in the reverse order to that followed at erection - see the applicable erection manual for new circuit-breakers.

1. Dismount the density switches and empty out the gas according to the instructions 051L05105. Put the plugs L-6 in the gas valves L-7 and mount the cover N-9 with the screw N-11 and the guide N-8.
2. Dismount the pull rods and protective tubes between the operating device and the circuit-breaker.
3. Place a strap under the upper flange on the support insulator and prepare for lifting with a hoisting crane (Figure L). Then loosen the mechanism housings at the 4 screws L-1 in the framework L-4.
4. Lift the insulator up and lay it carefully down on the transport wagon according to Figure M. Trestle under so that it lies horizontally. The trestling blocks M-2 under insulator shall be made of elastic material, e.g. cellular plastic or rubber. The frigidolite transport blocks on which the insulator lay at delivery should be kept for this purpose.
5. Transport to the factory or a new erection site shall be carried out with care in order to avoid damage to the insulators.
6. In order to facilitate continued renovation work the support insulator should be mounted vertically in an appropriate framework - e.g. a circuit-breaker framework.

NOTE: The following parts accompany the circuit-breaker on delivery from ASEA Brown Boveri and should be kept for future overhauls:

Transport cover	L-8	Screw	N-11
Plug	L-6	Cover	N-9
Block	M-2	Guide	N-8

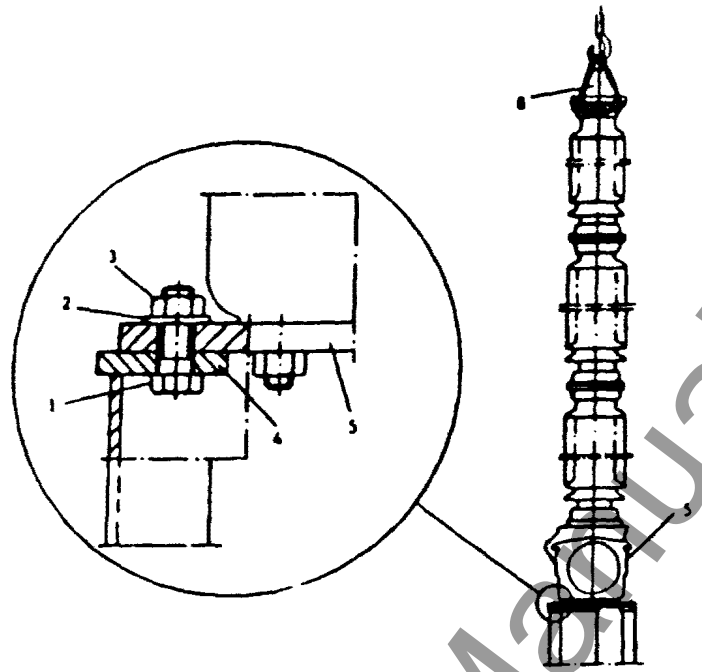

Figure L Dismounting of support insulator	
L-1	Screw 3/4" x 2 3/4"
L-2	Washer 3/4" FW
L-3	Nut 3/4" 220FT-1b.
L-4	Framework
L-5	Breaker pole
L-6	Plug
L-7	Gas filling valve
L-8	Transport cover

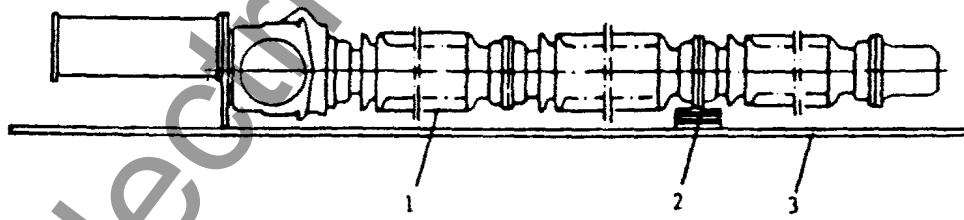
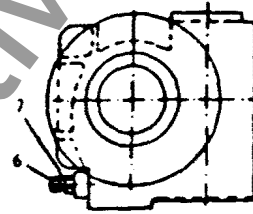

Figure M Transport of support insulator	
M-1	Support insulator
M-2	Trestling block
M-3	Transport platform

Tripping device Figure N

In order to facilitate dismounting of the support insulator and mechanism the opening springs N-5 must first be discharged and disconnected from the mechanism in the lower mechanism housing.

Working procedure:

1. Measure the dimension "x" and record it so that the same dimension can be set at mounting.
2. Discharge the springs N-5 by unscrewing the screw N-11 and dismounting the cover N-9 and the guide N-8.
3. Dismount the cap N-4.
4. Measure the dimension "Y" and record it so that the springs N-5 can be equally charged at remounting.
5. Dismount the springs N-5 and the guide disc N-6 by means of removing the nuts N-7.
6. Disconnect the pull rod N-3 by dismounting the pin N-2.

The component parts can now be cleaned and the springs antirust treated.

Prior to mounting, the supports for the pin N-2 and the rollers on the guide disc N-6 shall be lubricated with grease E - see the manual 051L05103.

Dismounting shall be carried out in the opposite order, after the support insulator and lower mechanism have been renovated and mounted.

The dimensions "X" and "Y" measured at dismounting shall be set so that the tension of the springs and the position of the mechanism will be the same as before.

For operation of the mechanism an operating lever, shown in Figure P, can be applied to the arm N-1.

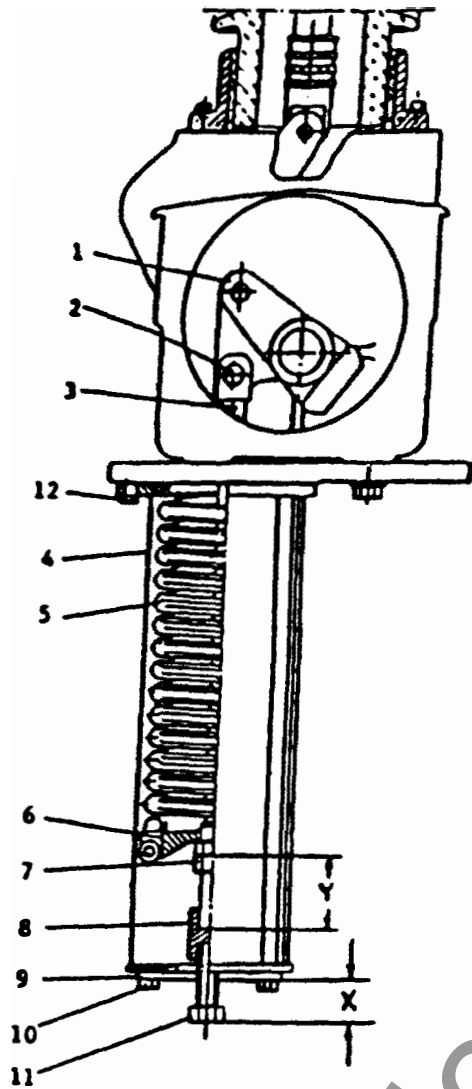

Figure N Tripping device

N-1	Arm
N-2	Pin
N-3	Pull rod
N-4	Cap
N-5	Opening spring
N-6	Guide disc
N-7	Nuts
N-8	Guide
N-9	Cover
N-10	Screw M10 x 30 33Ft-1b.
N-11	Screw M16 x 80
N-12	Screw M12 x 30 55Ft-1b.

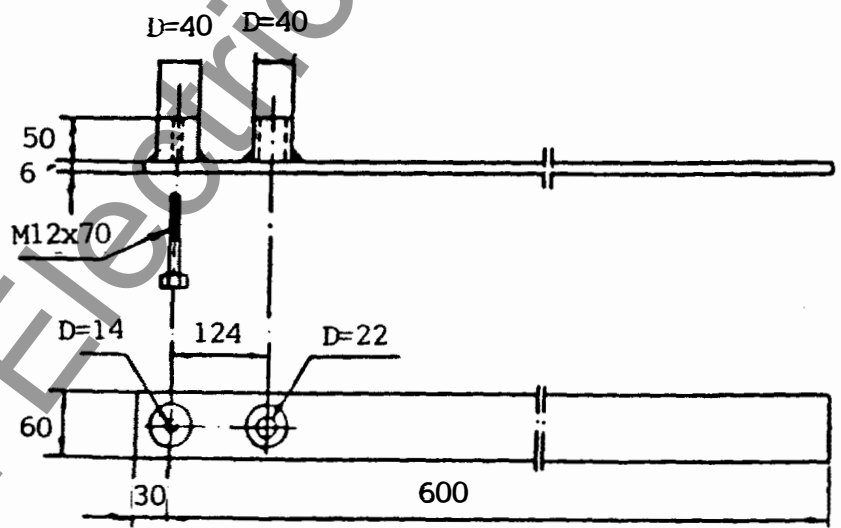

Figure P
 Operating lever article No. 5439 142-B

Renovation of support insulator

Depending on the basic insulation level and creepage to earth, the support insulator in HPL circuit-breakers for 245 kV and higher voltages can consist of 1 to 4 insulator units R-5-8. Above every insulator unit there is a guide R-2-19 for the operating insulator R-1.

Dismounting:

1. Dismount the upper guide R-2
2. Remove the screws R-10, lift up the support insulator approximately 7.7/8" and dismount the pin R-12 through the lower coupling piece of the operating insulator R-1.
3. Lift the insulator down to the floor, taking care not to damage the operating insulator.
4. Remove the screws R-6 from the lowest insulator and lift up the upper insulator R-5.
5. Remove the retaining ring R-18 from the guide R-19 and take away the bush R-20 (divided into 2 halves), with the band R-21. The operating insulators R-1 can now be freed entirely.
6. When there are more than 2 insulator units the procedure according to points 4 and 5 shall be repeated until all the insulator units have been dismounted.

Mounting:

After cleaning of all the parts and, if necessary, cleaning of the mechanism housing R-11, remounting in the reverse order shall be carried out, at which time new O-rings shall be put in throughout. See the instructions 051L05105.

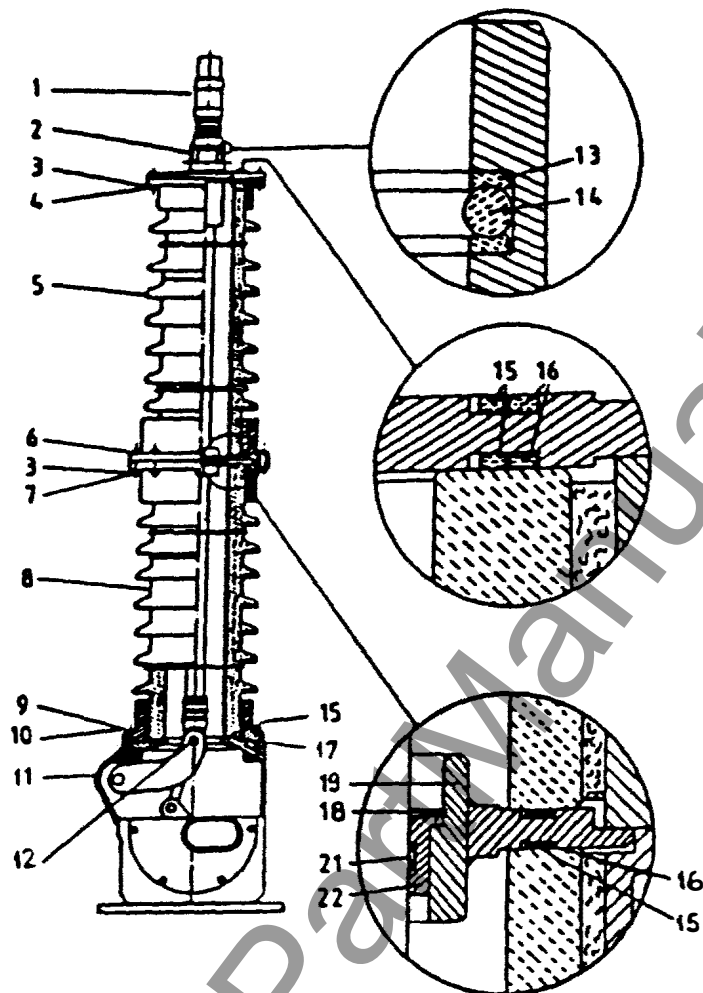

Figure R Support insulator

R-1	Operating insulator	R-12	Pin
R-2	Guide	R-13	Support ring
R-3	Washer 13.5 x 24 x 2	R-14	O-ring 72.6 x 5.5
R-4	Screw M12 x 30 37Ft-1b.	R-15	O-ring 159.3 x 5.7
R-5	Support insulator	R-16	O-ring 169.3 x 5.7
R-6	Screw M12 x 60	R-17	O-ring 184.3 x 5.7
R-7	Nut M12 55Ft-1b.	R-18	Retaining ring
R-8	Support insulator	R-19	Guide
R-9	Washer 17 x 30 x 3	R-20	Bush
R-10	Screw M16 x 50 125Ft-1b.	R-21	Band
R-11	Mechanism		

Figure S Mechanism

S-1	Mechanism housing
S-2	Operating shaft
S-3	Operating arm
S-4	Retaining ring
S-5	Ball bearing
S-6	Screw M12 x 40 55Ft-lb.
S-7	Bushing
S-8	O-ring 69.5 x 3
S-9	O-ring 94.5 x 3

Renovation of mechanism Figure S

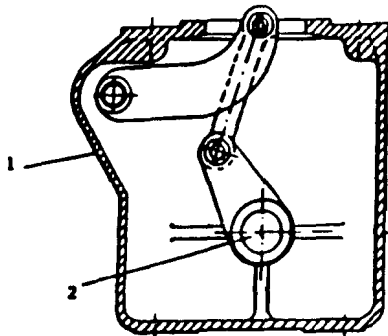

Cross section of mechanism housing showing inner mechanism

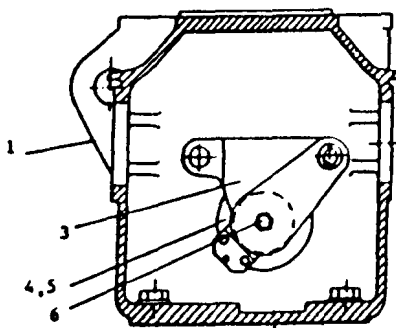

Cross section of mechanism housing showing outer mechanism (link gear)

Cross-section of bearing and gland box

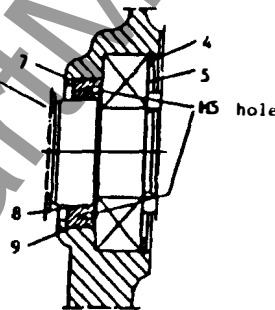

The mechanism housing shall be vacuumed and wiped clean.

The internal bearings are fitted with Teflon-coated bushes and do not need to be lubricated.

The operating shaft S-2 is, on the outside of the gas compartment, carried in a large ball bearing S-5, which will be accessible for inspection and lubrication if the arm S-3 and the retaining ring S-4 are dismantled.

The ball bearing and the external bearings for the rod system and tripping device shall be lubricated with grease E (see 051L05103). The O-rings S-8-9 in the gland box behind the ball bearing can, at the same time, be replaced with new ones, which shall be lubricated with grease H.

The bushing S-7 which holds the O-rings in place can be pulled out by means of mounting 2 M5 bolts into 2 M5 tapped holes in the front side of the bushing .

Mounting after renovation

Remounting of the support insulator with mechanism housing and tripping device shall be carried out in the reverse order.

1. Mount the operating insulator and the support insulator on the mechanism housing.
2. Mount the tripping device under the mechanism housing and set the spring tension - dimension "Y" - and the tightening position for the mechanism - dimension "X" - see Figure N.
3. When the dimension "X" has been set the mechanism will be in such a position that the upper part of the operating insulator R-1 provides gas-tight sealing of the support insulator in the guide flange R-2.

The support insulator with mechanism housing can now be vacuum pumped and filled with SF6 gas according to the instructions 051L05105.

4. After gas filling a check shall be made with the help of a sniffer or soapy water, that all the insulator joints and gaskets at covers and shaft passages are gas-tight.
5. Lower the pressure to 18 PSI abs and mount the transport cover M-8 with O-ring and the plug L-6.

Erection of circuit-breaker and start-up test

The breaking unit and the support insulator shall now be in much the same condition as when they were originally delivered from ASEA Brown Boveri.

The erection shall be carried out in accordance with the mounting instructions applicable to the circuit-breaker type in question.

Prior to taking the circuit-breaker into service a check shall be made that it is gas-tight and that the applicable function values have been maintained.

PRODUCT INFORMATION

MOTOR-OPERATED SPRING CLOSING DEVICE TYPE BLG 1002

DESIGNATIONS AND REFERENCES

When ordering spare parts and in inquiries and other correspondence the number of this instruction shall be given and the parts concerned designated as in the following example: "Contact pin 015L0507: AC-5 for motor-operated spring-closing device BLG 1002". The manufacturing number of the device according to the rating plate shall also be given, and for spare coils also the type of current and voltage in question and the applicable voltage for the motor.

CONTENTS		Page
	GENERAL DESCRIPTION	2
	Rapid auto-reclosing	3
	GENERAL INFORMATION ABOUT OPERATING DEVICE	3
	Unpacking	3
	Storage	3
	Erection	3
	Mechanical connection	3
	Electrical connection	3
	MODE OF OPERATION	5
	Charging of the closing springs	6
	Closing operation	7
	Opening operation	8
	Manual charging and discharging of the closing springs	9
	Manual closing impulse	10
	Manual opening impulse	10
	Mechanical interlocking against unintentional closing operation	11
	Cancelling of interlocking	12
	SLOW OPERATION	13
	Slow manual closing operation	15
	Slow manual opening operation	17
	AUXILIARY APPARATUS	19
	Control panel	19
	Limit switch	20
	Closing dashpot	22
	Opening dashpot	25
	Friction coupling	26

Motor	Page 27
Catch device with operating magnets	28
Mechanical tripping device	31
Auxiliary contact	32
Counter	33
Buffer for the charging chain	34
Heater	34
Thermal relay	34
MAINTENANCE	35
Cleaning	35
Lubrication	35

CAUTION! THE OPERATING DEVICE SHALL NOT BE OPERATED UNLOADED
Operation shall only be carried out after the device has been connected to, and adjusted together with, the appurtenant circuit-breaker

GENERAL DESCRIPTION

The motor-operated spring-closing device type BLG is intended for operating circuit-breakers with built-in opening springs which are charged by the operating device during the closing operation of the circuit-breaker and then store up the energy required for the opening operation. The operating device shall not, therefore, in any circumstances be operated with the spring battery charged without being connected to and set with the appurtenant circuit-breaker.

The operating device consists in principle of a spring battery which is charged by an operating motor with gear and an operating mechanism for releasing the closing and opening operations. The spring battery is automatically charged after every closing operation.

The various parts of the operating device are housed in a cubicle which also contains the control panel with operating equipment. In order to facilitate making connections and carrying out overhaul in the operating device, the roof of the cubicle can be folded upwards and the doors can, when necessary, be lifted off.

CAUTION! During transport and when the device is not in service the closing springs should, for reasons of safety be in the discharged position

Rapid auto-reclosing

Automatic rapid auto-reclosing can be carried out on condition that the closing springs are charged at the beginning of the operation. The relay equipment in the switchgear will in such a case give a closing impulse immediately after an opening and, if the fault is still present, immediately give a new opening impulse. As the circuits for the operating coils are electrically interlocked via the auxiliary contacts of the device, an ON-operation will first be completed before the OFF-operation is started, even if an opening impulse has been given during the ON-operation.

With the short operating times of the operating device, the requirements for speed placed on the device in order to obtain short currentless intervals are fulfilled.

The main components on an operating device BLG 1002 can be seen from figure A.

GENERAL INFORMATION ABOUT OPERATING DEVICE

Unpacking

A check for possible damages to the operating device shall be made during unpacking.

The operating device is delivered ready tested and set. No adjustment need, therefore, be made in connection with mounting on site.

Storage

The device should preferably be stored indoors in a dry room. If outdoor storage is necessary, the heater should always be switched on in order to prevent condensation of moisture. This also applies if the device is temporarily taken out of service.

Erection

The operating device shall be placed in accordance with the dimension print of the circuit-breaker. The base must be level. No skew tensioning may occur.

Mechanical connection

Connection of the operating rod between the operating device and the circuit-breaker shall be carried out in accordance with the instructions for the circuit-breaker which is to be connected to the operating device.

Electrical connection

The cable for operating and control circuits shall be drawn through the connection flange in the bottom of the control cubicle. The flange shall be fitted with a suitable pipe flange for the cable in question. The leads shall then be connected to the terminal blocks in accordance with the relevant connection diagram.

The earthing wire shall be connected to the earthing clamp A-21 on the side of the cubicle.

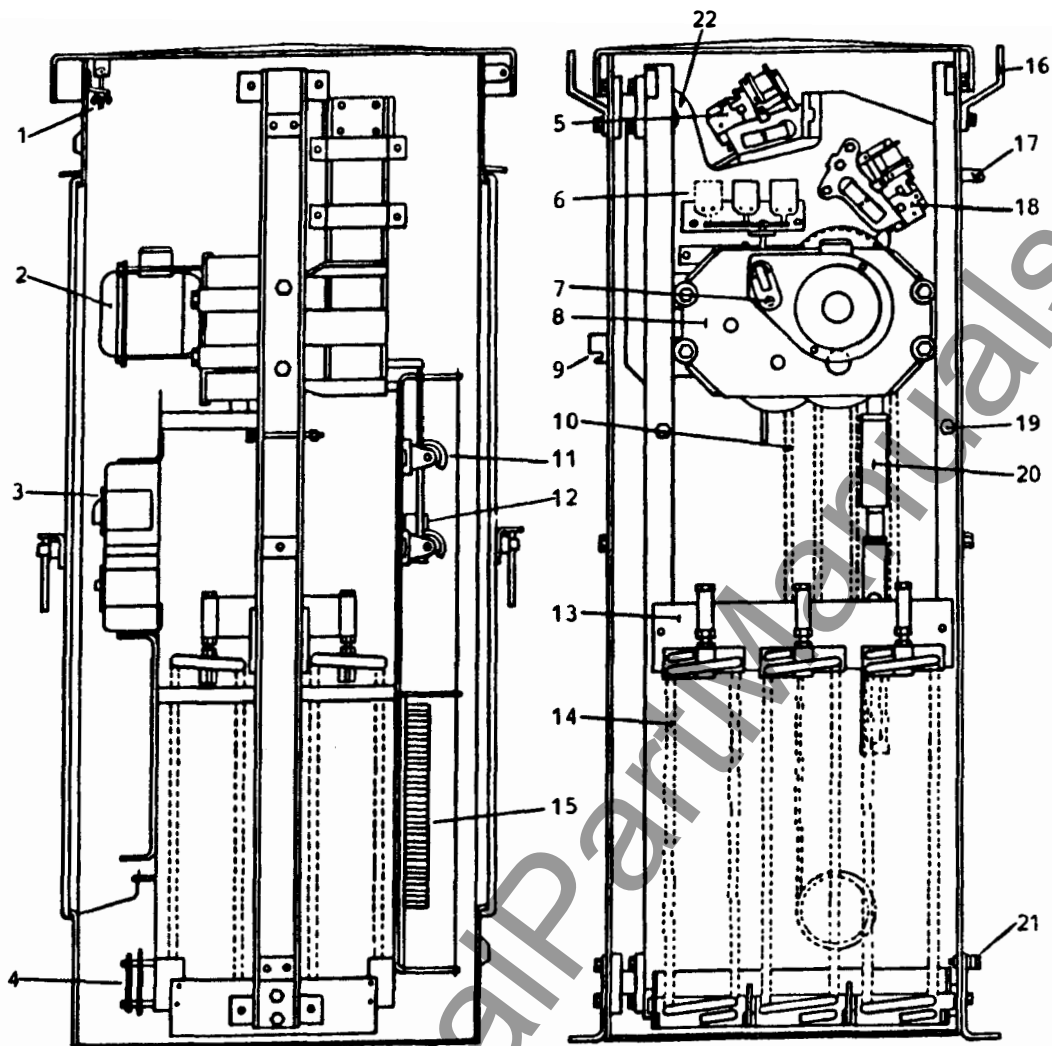

Figure A

A-1	Roof lock	A-13	Spring bridge
A-2	Driving motor	A-14	Closing spring
A-3	Control panel	A-15	Terminal blocks
A-4	Heater	A-16	Lifting lugs
A-5	Catch device for opening operation	A-17	Pull rod to the circuit-breaker
A-6	Limit switch	A-18	Catch device for closing operation
A-7	Hole for insertion of hand crank	A-19	End position stop for spring bridge A-13
A-8	Gear	A-20	Dashpot for closing operation
A-9	Push-button for mechanical opening operation	A-21	Earthing clamp
A-10	Endless chain	A-22	Dashpot for opening operation
A-11	Auxiliary contact with counter		
A-12	Thermal relay for heater		

MODE OF OPERATION

In principle the operating device functions as follows:

A cam disc B-15 and a spring bridge B-9 with springs B-10 are connected with an endless chain B-8. The chain, which is placed in two loops over a motor-driven sprocket B-16, functions as a transmission element when the springs B-10 are charged, and drives the cam disc B-15 round during a closing operation. The cam disc during its rotation actuates the operating arm B-3 which converts the rotary movement into a linear movement on the pull rod B-13.

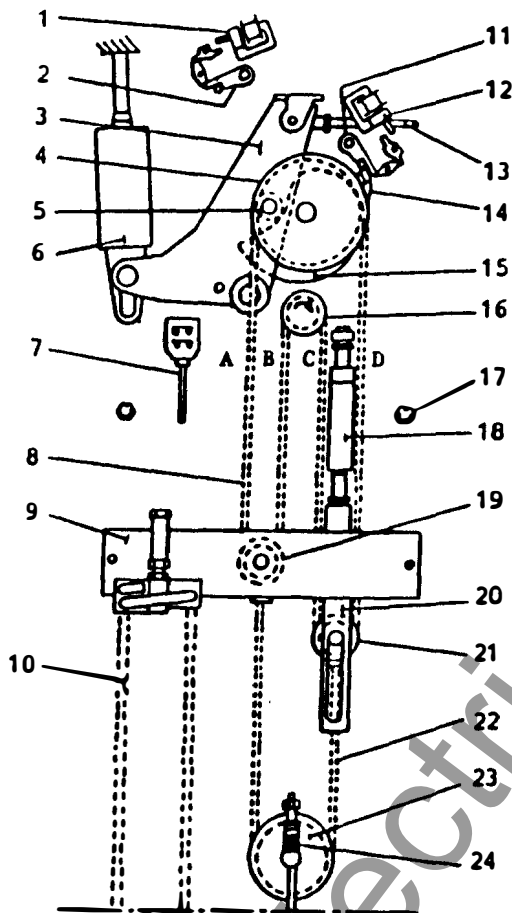

Figure B The operating device in the open position with discharged closing springs

B-1	Trip magnet
B-2	Main opening catch
B-3	Operating arm
B-4	Sprocket
B-5	Stop roller
B-6	Dashpot for opening operation
B-7	Limit switch
B-8	Endless chain
B-9	Spring bridge
B-10	Closing springs
B-11	Main closing catch
B-12	Closing magnet
B-13	Pull rod to the circuit-breaker
B-14	Locking lug
B-15	Cam disc
B-16	Driving sprocket of the gear
B-17	End position stop for spring bridge B-9
B-18	Dashpot
B-19	Sprocket
B-20	Guide link
B-21	Sprocket
B-22	Charging chain
B-23	Deflector wheel
B-24	Buffer for charging chain B-22

Charging of the closing springs

The motor circuit is always closed by the limit switch B-7 when the closing springs are discharged. If the motor starter on the control panel is closed the motor will start and drive the sprocket B-16 of the gear round in the direction of the arrow. When the sprocket B-4 with the cam disc B-15 is locked with its locking lug B-14 against the main closing catch B-11, the endless chain B-8 is therewith anchored to this sprocket. Consequently, the endless chain on section B will move upwards, on section C downwards, while on sections A and D it will remain motionless.

As the chain is fed forward over the driving sprocket B-16 the sprocket B-19 with appurtenant spring bridge will be lifted upwards at the same time as the sprocket B-21 moves downwards the same distance.

The charging chain B-22 which runs over the deflector wheel B-23 is fixed at one end to the shaft on the sprocket B-19 and at the other end to the shaft for the sprocket B-21. The purpose of the charging chains is to keep the endless chain stretched.

Just before the spring bridge B-9 reaches its highest position it actuates the limit switch B-7 so that it interrupts the current to the motor, whereupon the spring bridge stops somewhat before the end position stop B-17 as shown in figure C.

During the charging movement the shaft for the sprocket B-21 has moved from the upper end of the groove in the guide link B-20 to the lower end and has pulled with it the guide link B-20 including the dashpot cylinder B-18 a further distance downwards so that the piston in the dashpot has reached its upper position. See figure C. A built-in catch E-6 in the gear prevents the gear sprocket B-16 from rotating backwards. See figure E.

Closing operation

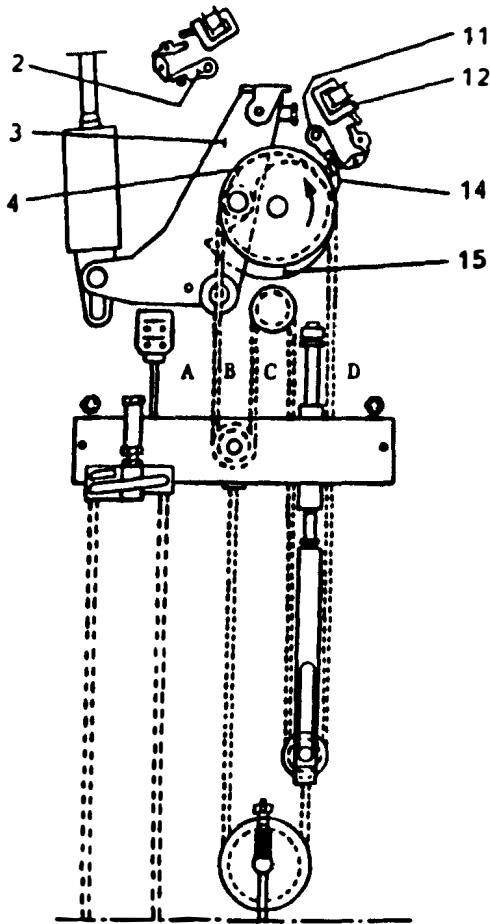

Figure C

The operating device in the open position with charged closing springs

C-2	Main opening catch
C-3	Operating arm
C-4	Sprocket
C-11	Main closing catch
C-12	Closing magnet
C-14	Locking lug on sprocket C-4
C-15	Cam disc

The tensile force of the closing springs is taken up by the endless chain on sections A and B.

At an impulse to the closing magnet C-12 the main closing catch C-11 is freed from its grip against the locking lug C-14 of the sprocket. By means of the tensile force of the closing springs in the endless chain on section A the sprocket C-4 with cam disc C-15 is driven round in the direction of the arrow. During its one-revolution movement the cam disc actuates the operating arm C-3 which is pressed over to the left and locked by the main opening catch C-2 in the closed position as shown in figure D.

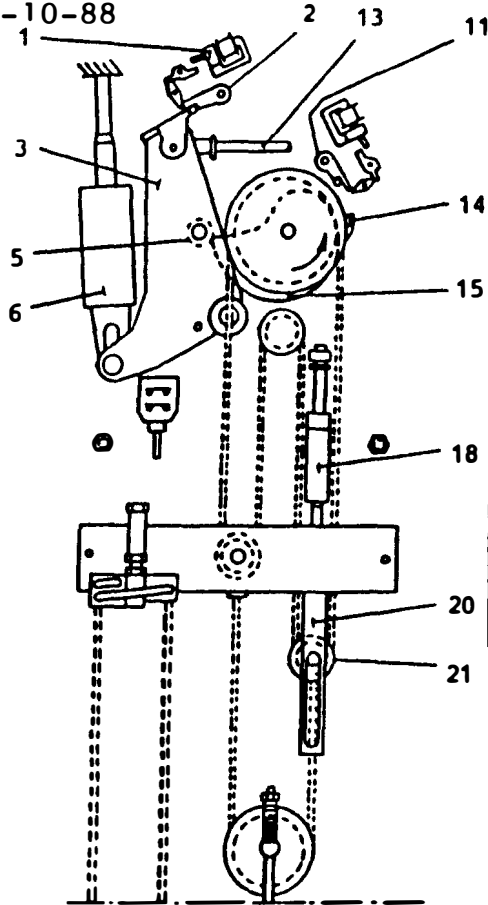

Figure D

Closing of the operating device

D-1	Trip magnet
D-2	Main opening catch
D-3	Operating arm
D-5	Stop roller
D-6	Dashpot for opening operation
D-11	Main closing catch
D-13	Pull rod to the circuit-breaker
D-14	Locking lug
D-15	Cam disc
D-18	Dashpot
D-20	Guide link
D-21	Sprocket

Figure D shows the position during the closing operation when the cam disc D-15 has in its revolution just left the stop roller D-5. The shaft in the sprocket D-21 has then passed the free section in the guidelink D-20 and begins to press the link and the dashpot cylinder D-18 upwards. The final part of the revolution of the cam disc is thus braked by the dashpot so that the final position with the locking lug D-14 resting against the main closing catch D-11 is reached with a slowing-down movement.

The final position of the cam disc and the dashpot cylinder can be seen in figure B.

Opening operation

Opening of the operating device and circuit-breaker is carried out by means of an impulse to the trip magnet D-1 or by pushing in the OFF pushbutton A-9 located on the outside of the cubicle of the operating device. The operating arm D-3 will then be freed from its grip against the main opening catch D-2, whereupon the opening spring of the circuit-breaker will pull the operating arm into the open position.

The open position of the operating arm with the stop roller D-5 resting against the cam disc is shown in figure B.

Manual charging and discharging of the closing springs

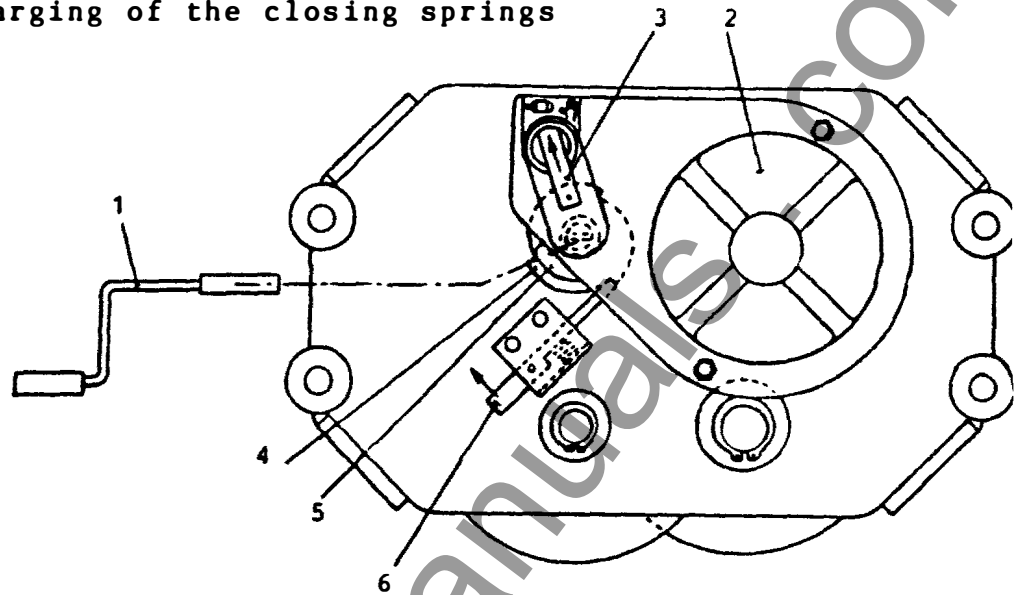

Figure E Gear A-6			
E-1	Hand crank	E-4	Ratchet wheel
E-2	Motor	E-5	Friction coupling
E-3	Cover plate with knob	E-6	Catch

The closing springs of the operating device can be manually charged with the hand crank E-1. The knob E-3 shall be moved away from the motor to the hand-operated position as shown in the figure, and the crank shall be placed on the shaft. When the crank is turned counterclockwise the closing springs will be charged.

The knob E-3 operates a contact which disconnects the motor voltage when the knob is moved into the manual charging position.

The crank E-1 shall be kept in a holder in the operating device cubicle.

When the spring bridge has been cranked fully up against the end position stop B-17 the friction coupling E-5 will begin to slide if the cranking is continued.

The gear is fitted with a catch E-6 which prevents the gear wheel from rotating backwards when the cranking is interrupted.

If a return to discharged closing springs is required without operating the circuit-breaker, the motor voltage shall first be interrupted with the pushbutton "OFF" P-6 and then the crank shall be placed in the hand-operating position as described above.

The crank shall be turned counterclockwise so far that the catch E-6 is released and the crank shall be kept in that position. The catch E-6 shall be moved aside in the direction of the arrow until the catch is freed from the cogs in the ratchet wheel E-4. By means of releasing the crank clockwise while holding back, the spring battery can be discharged. The discharging operation can be interrupted in any position by means of releasing the catch E-6.

Manual closing impulse

When the circuit-breaker is in the open position and the closing springs are fully charged the auxiliary contact and the limit switch in the closing circuit will be closed.

The control switch P-5 on the control panel shall be in the "LOCAL" position.

A manual closing impulse should only be given electrically by pressing the ON pushbutton P-7 on the control panel, whereupon the closing magnet will trip out the operation.

If for some reason it should be considered absolutely necessary to give a mechanical manual closing impulse, this can be carried out by means of giving a light tap on the magnet arm X-2. It must be noted that the impulse must be short as otherwise the locking lug C-14, after a completed whole revolution, will have passed the roller on the main closing catch C-11, whereupon the interlocking disc F-3 of the cam disc will lie against the interlocking arm F-2.

If this occurs, the procedure described under the heading "Cancelling of interlocking" according to figure H shall be followed in order to reset the mechanism in the normal position.

Caution: A manual mechanical closing impulse may be executed only by a qualified person. This is someone who is intimately familiar with the operation of the circuit breaker and operating mechanism and who is absolutely certain about what can happen when the electrical blocks and interlocks are removed (as they will be during this mode of operation).

Caution: Never give a manual mechanical closing impulse when the closing springs are charged, unless the operating device is connected to the circuit-breaker and all adjustments have been made.

Manual opening impulse

When the circuit-breaker is in the closed position the auxiliary contact in the opening circuit of the operating device will be closed.

The control switch P-5 on the control panel shall be in the "LOCAL" position.

A manual opening impulse can either be given electrically or mechanically.

An electric opening impulse shall be given by pressing the "OFF" pushbutton P-6 on the control panel, whereupon the trip magnet will trip out the operation.

A mechanical opening impulse shall be given by pressing the "OFF" pushbutton on the outside of the cubicle. See figure AA. The operating rod AA-2 will pass the movement on to the auxiliary opening catch AA-14, which will trip out the operation.

Mechanical interlocking against unintentional closing operation
 If the circuit-breaker is already in the closed position or if the closing springs of the operating device are discharged or not fully charged, a closing operation may not be carried out. In order to prevent such an unintentional operation which can, for instance, occur if the closing catch is opened manually or if there is some mechanical fault on the catch, the operating device has been fitted with an interlocking mechanism as shown in figure F.

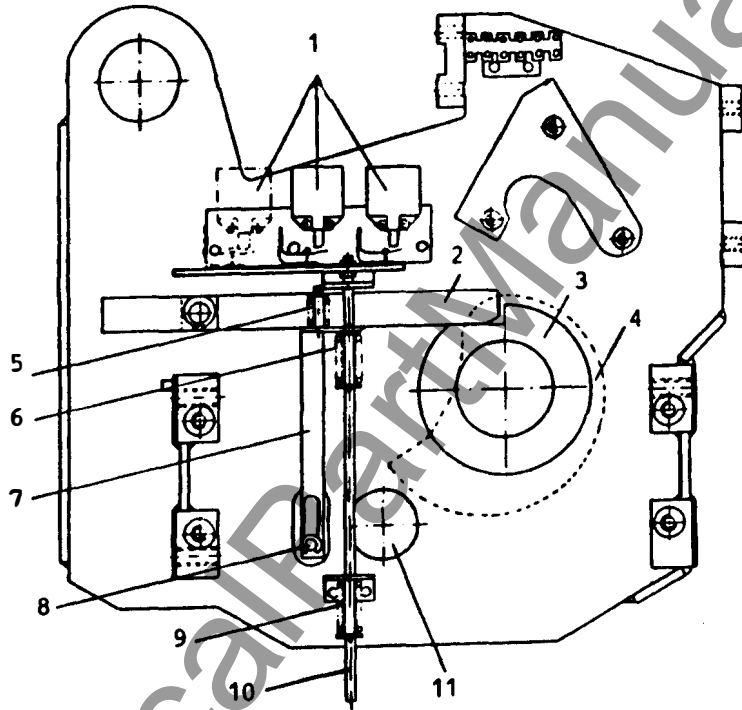

Figure F Interlocking mechanism

F-1	Limit switch. See figure R	F-7	Link
F-2	Interlocking arm	F-8	Pin
F-3	Interlocking disc	F-9	Spring
F-4	Cam disc	F-10	Operating rod
F-5	Spring	F-11	Shaft for the operating arm B-3
F-6	Spring		

The figure shows the position of the interlocking mechanism when the operating device is in the closed position with discharged closing springs. The interlocking arm F-2 is interlocked in front of the interlocking disc F-3 which always follows the movement of the cam disc F-4. A renewed closing operation is thus not possible before the closing springs have been completely charged and the operating device has been operated into the open position, regardless of sequence.

When the closing springs are being charged and the spring bridge A-13 is nearing the end position it presses the operating rod F-10 upwards so that the limit switch F-1 changes position and the motor stops. The spring F-6 tries to lift the interlocking arm F-2 but its lifting capacity is neutralized by the spring F-5.

If the operating device is operated into the open position the pin F-8, which follows the movement of the operating arm B-3, will move from the upper position in the groove on the link F-7. The spring F-6 will then lift both the interlocking arm F-2 and the link F-7 upwards so that the interlocking disc F-3 is deblocked.

When the order is reversed, i.e. if the opening operation is carried out first, the lifting capacity of the spring F-6 will be neutralized by the spring F-9, for which reason the interlocking arm remains in the locked position until the closing springs are charged.

Canceling of interlocking

If the movement of the cam disc has for some reason been stopped by the interlocking arm F-2, a closing operation cannot be carried out before the cam disc has been returned to its normal position with the locking lug B-14 resting against the roller on the main closing catch B-11. This shall be done in the following way:

1. The spring bridge shall be placed in a lockable position according to figure G.
2. The gear shall be cranked clockwise until the locking lug B-14 of the sprocket has gone well past the roller on the main closing catch B-11.
3. The cause of the fault shall be remedied.
4. The spring bridge shall be again taken out of its locked position and the closing springs shall be charged. A trial operation shall be made.

SLOW OPERATION

Certain mounting and overhauling work requires slow operation of the circuit-breaker. This can be carried out if the following conditions are fulfilled:

1. The motor-and operating voltages shall be interrupted
 2. The spring bridge shall be blocked according to figure G.
 3. The interlocking mechanism shall be put out of operation
1. The motor voltage shall be interrupted with the pushbutton P-11 and the operating voltage with the switch P-5.
 2. Blocking of the spring bridge

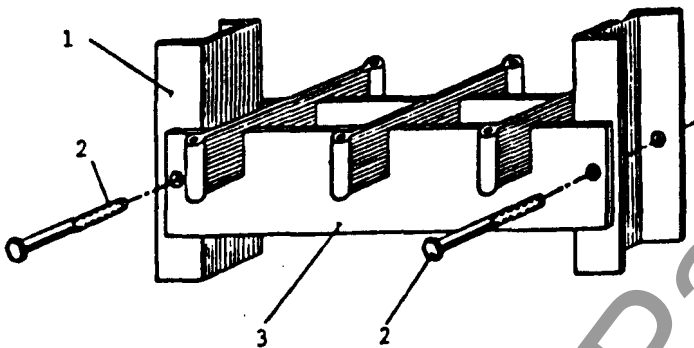

G-1	Guide bar
G-2	Lock bolt
G-3	Spring bridge B-9

The spring bridge G-3 shall be blocked at the guide bars G-1 with the lock bolts G-2.

If the closing springs are discharged they shall be charged by means of operating the gear with the hand crank (counterclockwise) until the holes in the spring bridge center with the holes in the guide bars.

If the closing springs are charged, they shall be discharged with the help of the hand crank (clockwise) until the lock bolts G-2 can be mounted.

The method of using the hand crank can be seen under the heading "Manual charging and discharging of the closing springs".

The lock bolts G-2 shall be stored in a holder in the operating device cubicle.

3. Blocking of the interlocking mechanism

Figure H shows the interlocking mechanism when the operating device is in the open position with discharged closing springs.

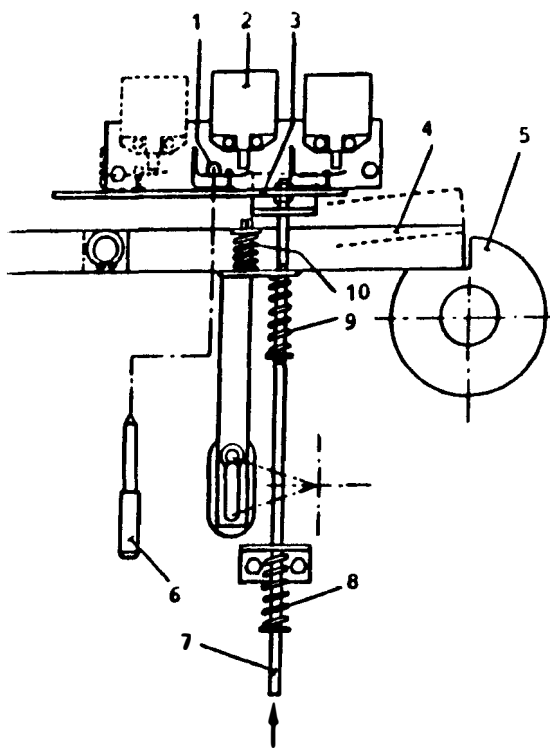

Figure H

H-1	Hole
H-2	Limit switch
H-3	Bridge
H-4	Interlocking arm
H-5	Interlocking disc on cam disc F-4
H-6	Lock pin
H-7	Operating rod
H-8	Spring
H-9	Spring
H-10	Spring

The operating rod H-7 on the bridge H-3 shall be pressed upwards and the lock pin H-6 shall be inserted into the hole H-1 so that the bridge H-3 is hanging on the pin. The interlocking arm H-4 will then take up the position marked by dots on the figure and will thereby be put out of operation.

The lock pin H-6 shall be stored in a holder in the operating device cubicle.

When the operating mechanism is in closed position, the interlocking arm can be pushed down against the interlocking position. When turning the hand crank counterclockwise according to point 3 under slow manual opening, the interlocking arm thus must be lifted up in order to get deblocking.

Slow manual closing operation

Starting position: Circuit-breaker in the open position, motor- and operating voltages interrupted, spring bridge and interlocking mechanism in blocked position.

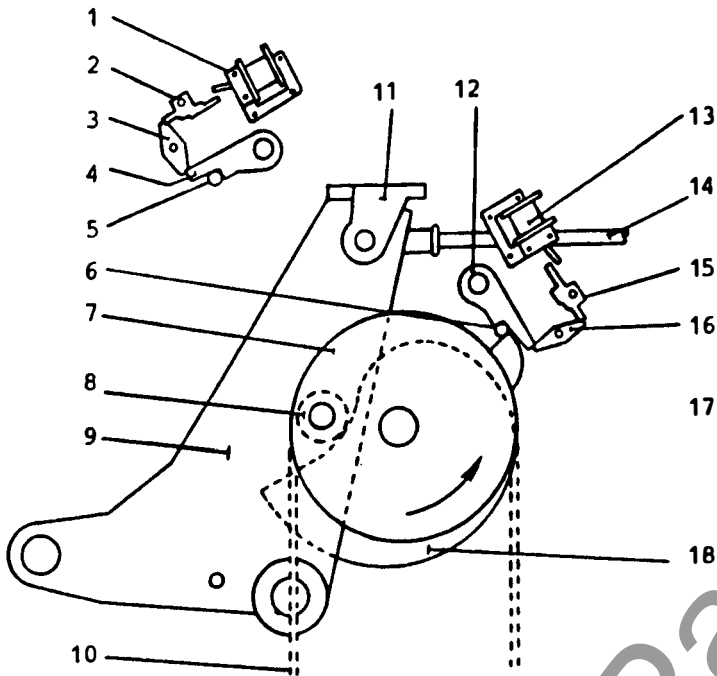

Figure K	
K-1	Trip magnet
K-2	Auxiliary switch
K-3	Intermediate catch
K-4	Main opening catch
K-5	Roller
K-6	Roller
K-7	Sprocket
K-8	Stop roller
K-9	Operating arm
K-10	Chain
K-11	Locking lug
K-12	Main closing catch
K-13	Closing magnet
K-14	Pull rod
K-15	Auxiliary catch
K-16	Intermediate catch
K-17	Locking lug
K-18	Cam disc

Slow closing of the circuit-breaker shall be carried out as follows:

1. The crank shall be placed in the hand-operating position as shown in figure E.
2. Either the magnet arm on the closing magnet K-13 shall be pressed in or the auxiliary catch K-15 shall be moved aside so that the intermediate catch K-16 is released. A normal closing operation should then take place if the spring bridge A-13 were not in the locked position. The spring bridge therefore moves downward only as far as the clearance in the holes for its lock bolts G-2 permits, and then the closing operation is interrupted.

The short downward movement of the spring bridge is, however, sufficient for it via the chain K-10, to drive the sprocket K-7 clockwise so far that the locking lug K-17 can pass the catch roller K-6 of the main closing catch. The operating device is now ready for a slow closing operation.

3. Approximately 245 counterclockwise revolutions shall be cranked. The cam disc K-18, which therewith rotates approximately 3/4 revolution counterclockwise, actuates the stop roller K-8 so that the operating arm K-9 and also the circuit-breaker are slowly moved over to the closed position.

Towards the end of the movement a click will be heard when the locking lug K-11 of the operating arm engages behind the roller K-5 on the main opening catch. The position of the mechanism at that stage is illustrated in figure L.

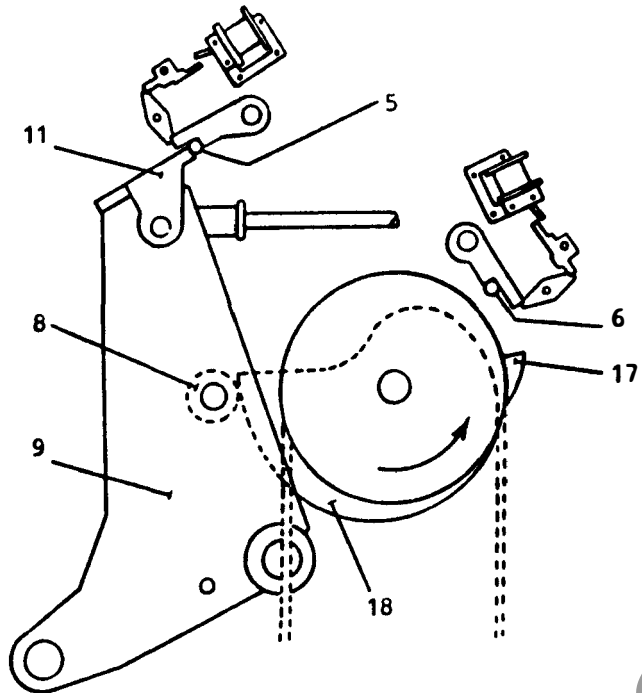

Figure L	
L-5	Catch roller
L-6	Catch roller
L-8	Stop roller
L-9	Operating arm
L-11	Locking lug
L-17	Locking lug
L-18	Cam disc

Further counterclockwise cranking shall be carried out until the outermost tip of the cam disc L-18 has left the stop roller L-8. The operating arm L-9 will thus be freed and drawn towards the open position by the force in the opening springs of the circuit-breaker until the locking lug L-11 meets the catch roller L-5 with a forceful thud and remains there.

- The cam disc shall be cranked in the normal position until the locking lug L-17 rests against the catch roller L-6 and further until the lock bolts G-2 of the spring bridge are unloaded.

The circuit-breaker will now be in the closed position and a normal opening operation can be carried out.

- The operating device shall be returned to its original condition after a completed manual operation, by means of deblocking the spring bridge and the interlocking mechanism.

A started slow closing operation can be interrupted in any position between the locking positions. When cranking is carried out in the opposite direction (clockwise) the circuit-breaker goes slowly towards the open position.

Slow manual opening operation

A slow opening operation implies "fetching" the circuit-breaker with the cam disc and then cranking the circuit-breaker into the open position.

Starting position: Motor- and operating voltages interrupted, spring bridge and interlocking mechanism in the blocked position.

The cam disc must must always be rotated in the direction of the arrow when fetching the circuit-breaker. Rotation in the other direction will cause severe damage to the operating mechanism

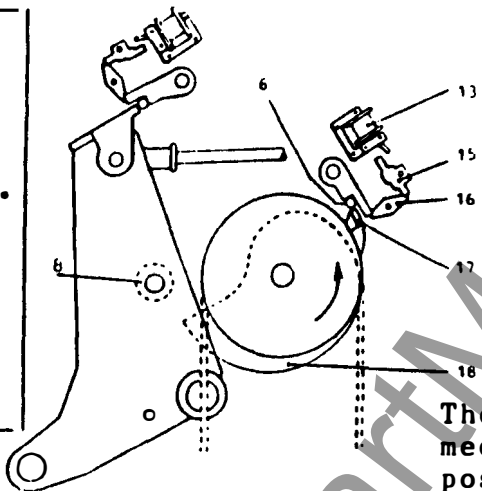

Figure M

M-6	Roller
M-8	Stop roller
M-13	Closing magnet
M-15	Auxiliary catch
M-16	Intermediate catch
M-17	Locking lug
M-18	Cam disc

The figure shows the mechanism in the closed position.

1. The crank shall be placed in the hand-operated position according to figure E and approximately 10 counterclockwise revolutions shall be cranked.
2. The auxiliary catch M-15 shall be freed from its grip in the intermediate catch M-16. The operating device will then trip out but the started closing operation will be stopped because the spring bridge is blocked. The cam disc M-18 will therefore move in the direction of the arrow just far enough for the locking lug M-17 to be freed from the grip against the roller M-6.

WARNING! Because of the fact, that the circuit-breaker is in the closed position, the interlocking arm H-4 is pulled down by the operating arm. This interlocking arm must be lifted manually in order to be able to release the locking lug M-17.

3. Counterclockwise cranking shall be carried out for approximately 235 revolutions or until the cam disc has only just begun to touch the stop roller M-8, which can be felt because of greater resistance to winding of the crank. Then a few clockwise revolutions shall be cranked so that a little play occurs between the stop roller M-8 and the cam disc.

The position of the mechanism at that stage is shown in figure N.

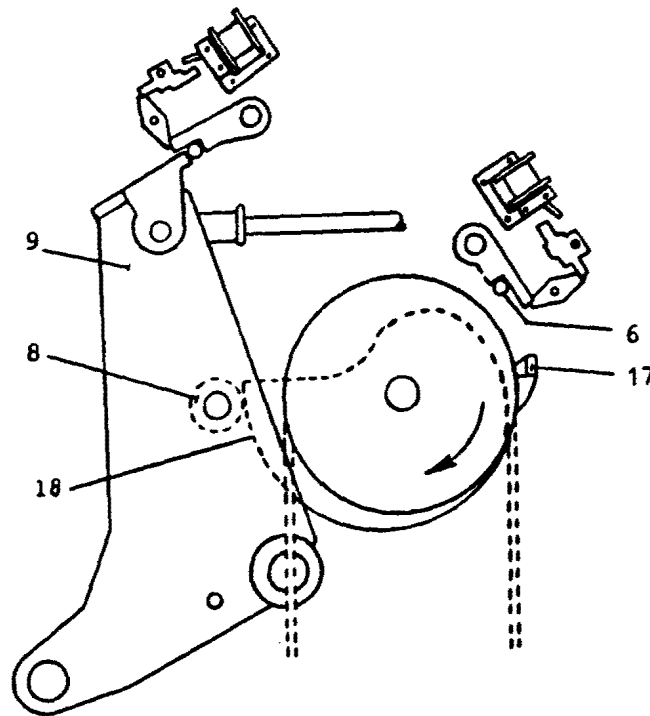

N-6	Roller
N-8	Stop roller
N-9	Operating arm
N-17	Locking lug
N-18	Cam disc

4. The opening operation shall be released by means of pushing in the "OFF" button on the outside of the operating device. The opening springs of the circuit-breaker will then draw the operating arm N-9 towards the open position, but the movement will be stopped when the stop roller N-8 touches the cam disc N-18.
5. Clockwise cranking shall be carried out while pressing in the catch E-6. The cam disc will then also rotate clockwise so that the circuit-breaker is slowly drawn by the opening springs towards the open position.

The cranking shall be continued until the locking lug N-17 has passed the catch roller N-6 and taken up the position shown in figure K.
6. The operating device shall be returned to its original condition after completed hand-operation, by means of deblocking the spring bridge and the interlocking mechanism.

CAUTION: Before proceeding, check that both the interlocking arm and the interlocking lug of the cam disc are in their proper positions.

AUXILIARY APPARATUS

Control panel
 (typical)

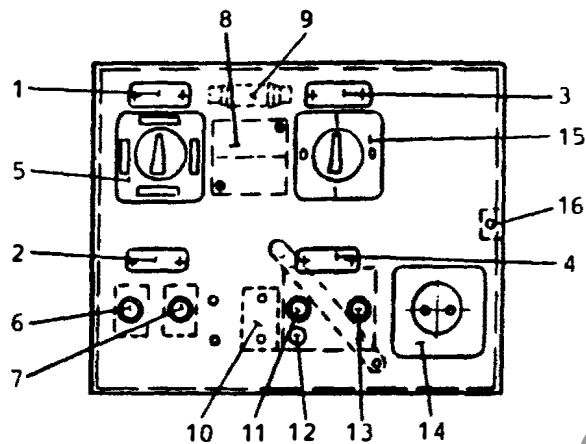

Figure P

P-1	Plate: Operating voltage
P-2	Plate: Operation
P-3	Plate: Heat for cubicle
P-4	Plate: Motor voltage
P-5	Switch for operating circuit
P-6	Pushbutton for electrical "OFF" operation
P-7	Pushbutton for electrical "ON" operation
P-8	Contacter for the motor-circuit
P-9	Series resistor for P-8 (only 220 V DC)
P-10	Anti-pumping relay
P-11	Pushbutton for interrupting the motor circuit
P-12	Setting of thermal release on motor starter
P-13	Pushbutton for switching in the motor circuit
P-14	Socket for portable lamp or something similar
P-15	Switch for heater
P-16	Lock Screw for control panel

The placement of the control panel can be seen from figure A. It is suspended on the hinge and fixed with a screw P-16. If the screw is removed the control panel can be swung outwards e.g. for inspection of its reverse side.

The switch P-5 has the following three positions: "DISCONNECTED" "LOCAL" and "REMOTE" operation.

Local electrical operation shall be carried out by means of the pushbuttons P-6 (OFF) and P-7 (ON).

The motor circuit shall be switched in by means of the pushbutton P-13 of the motor starter and disconnected with the pushbutton P-11.

Adjustment of the thermal overload protection P-12 can be carried out through the hole in the control panel. It is set at delivery.

The socket P-14 is intended for connection of a portable lamp, electric hand tools, a recording drum etc.

The switch P-15 is used for switching on the two heaters A-14. When the knob on the switch is at "1", one of the heaters (100W) is continuously switched on. The other (500W) is automatically switched on and off by the thermal relay A-12. If the switch is at "0" both the heaters are switched off.

Operating devices connected to SF6 circuit-breakers are normally complemented with interlocking relays placed on the plate under the control board. Their purpose is, at impermissibly low pressure in the circuit-breaker due to leakage, to give an alarm signal and to switch off the electrical operating circuits.

The operating coils of the relays are connected and disconnected by the micro-switches in the density switch(es) of the circuit-breaker when the density of the SF6-gas has sunk to an unacceptable low level. Normally the closing circuit as well as the opening circuit are interrupted by their blocking relays at the same blocking pressure. A low pressure alarm circuit is connected by a second micro-switch in the density switch at a pressure level 3 PSI abs. above the blocking pressure.

Limit switch

The limit switch consists of two contact devices R-1:3 and R-1:2 and a mechanism for operating them. On request a third contact device R-1:1 can be mounted.

In every contact device there are a fixed and a moving contact. The latter is fitted with a snap mechanism which gives rapid contact changeover.

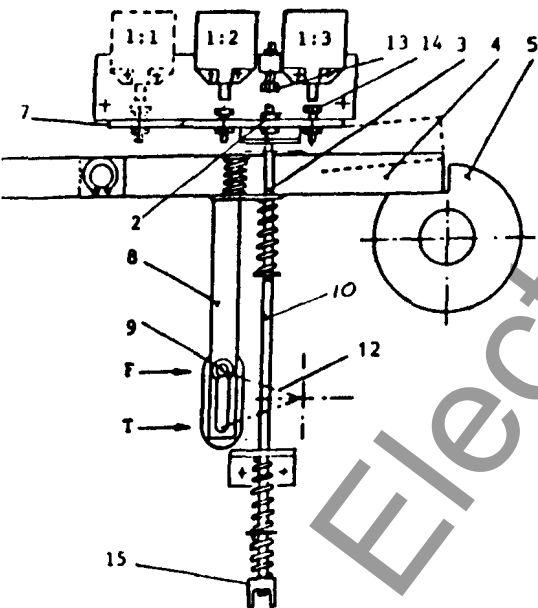

Figure R	
R-1	Contact device
R-2	Lock nut
R-3	Pin
R-4	Interlocking arm
R-5	Interlocking disc on cam disc F-4
R-7	Bridge
R-8	Link
R-9	Pin on arm R-12
R-10	Operating rod
R-11	Upper end position of the spring bridge
R-12	Arm
R-13	Stop
R-14	Adjusting screw
R-15	Resilient head
T	Closed position
F	Open position

When the closing springs are charged and the spring bridge (A-13) nears the upper end position R-11 it actuates the operating rod R-10 in an upwards direction. Thus the interlocking arm R-4 and the bridge R-7 are lifted to the positions marked by dots on the figure at the same time as the contact devices change position (the motor current is interrupted by R-1:2 and the "ON" circuit is switched in by R-1:3).

During a closing operation of the circuit-breaker the interlocking disc R-5 starts its one-revolution movement at the same time as the pin R-9, in step with the circuit-breaker, moves from the upper end of the oval groove in the link R-8 to the lower end. The interlocking arm R-4 then leaves the dotted position and tries to go into the locked position but remains "hanging" on the periphery of the interlocking disc. When the interlocking disc has completed its whole revolution the interlocking arm can go into the locked position. Where upon the contact devices change position (the motor starts and the "ON" circuit is interrupted).

It is necessary that the contact device R-1:3 of the "ON" circuit should close a little before the contact device R-1:2 of the motor circuit interrupts (see figure S). Otherwise there is a risk that the closing operation cannot take place even though the closing springs are charged. In order to eliminate that risk the screw R-14 for R-1:3 shall be adjusted so that the contact device 1:3 close $5/64$ " before the contact device 1:2 interrupt.

During overhaul or replacement of the contact device a check should be made that the dimensions given in figure R are maintained. A check shall be made by means of manual charging of the closing springs that the contact device R-1:3 changes position approximately $1/16$ " - $5/64$ " before the contact device R-1:2 and that the spring bridge, when the later contact device changes position, are $3/8$ " under the upper end position stop B-17.

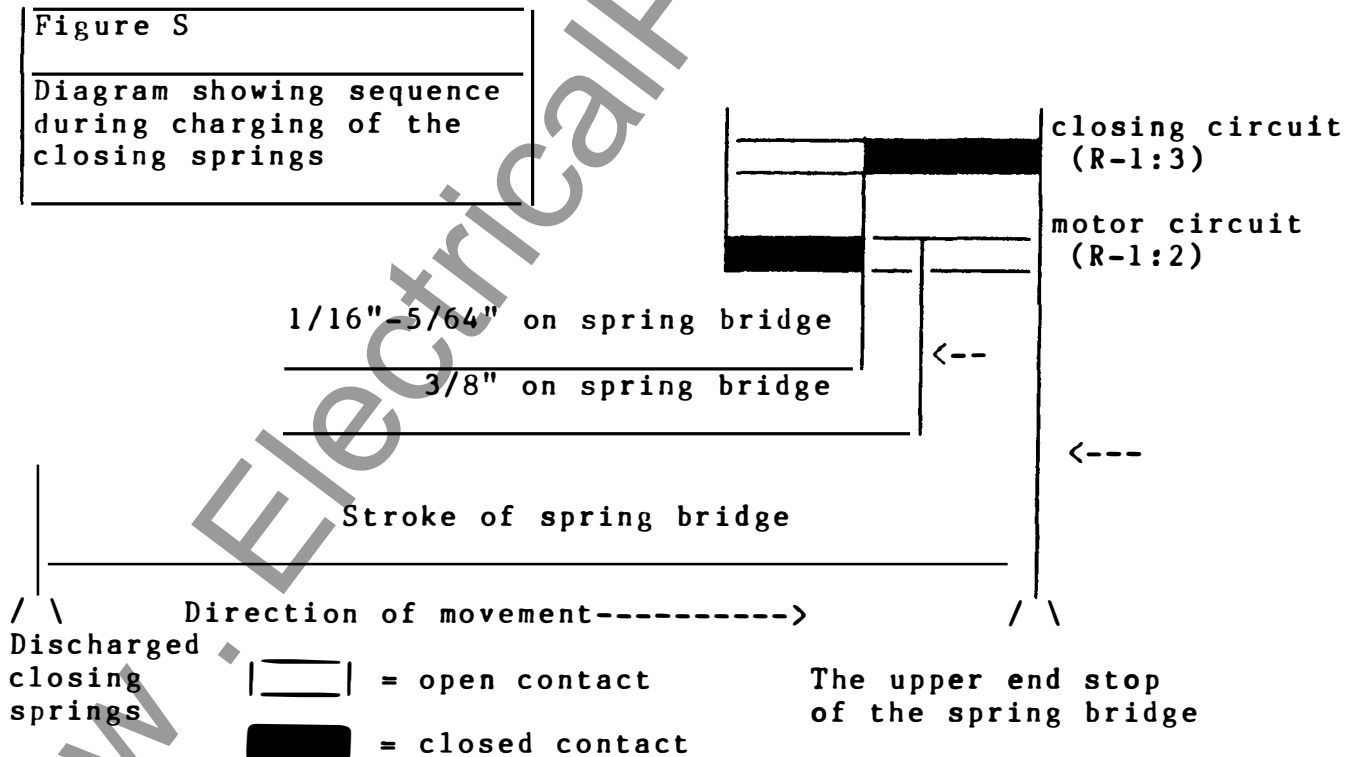

The purpose of the closing dashpot is to damp the rotary movement of the cam disc after a completed closing operation.

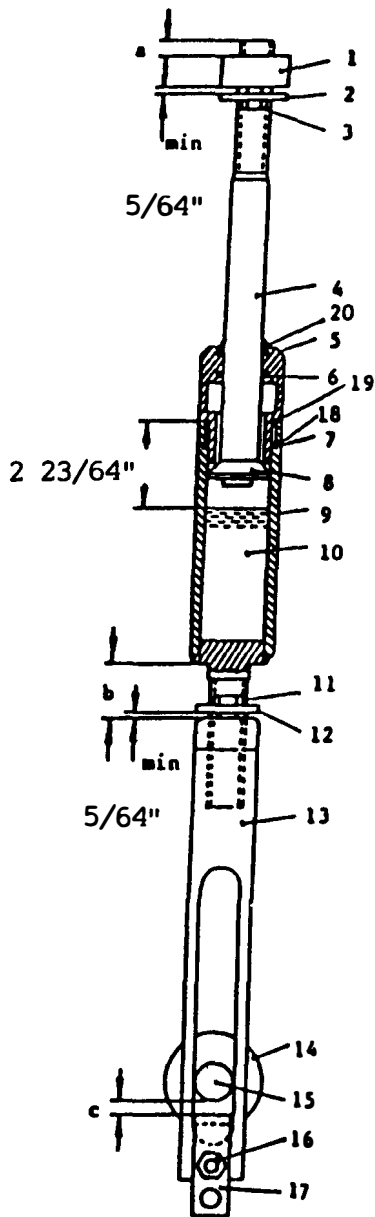

Figure T

T-1	Holder
T-2	Washer
T-3	Lock screw M8x25 15Ft-1b
T-4	Piston rod
T-5	Cover
T-6	O-ring
T-7	O-ring
T-8	Piston
T-9	Cylinder
T-10	Oil
T-11	Lock screw M8x25 15Ft-1b
T-12	Lock washer
T-12	Guide link
T-14	Sprocket
T-15	Shaft
T-16	Self-locking nut
T-17	Bar
T-18	Plastic ring
T-19	O-ring
T-20	Wiper

At delivery tests on the operating devices the dashpots shall be set (dimension "c") with regard to the recorded damping curve, Figure TA. This is obtained by means of indicating the entire revolution of the cam disc with the help of a recording drum. The indicating rod for the recording drum shall be connected to a measuring arm which shall be screwed onto the shaft for the cam disc - see Figure TB.

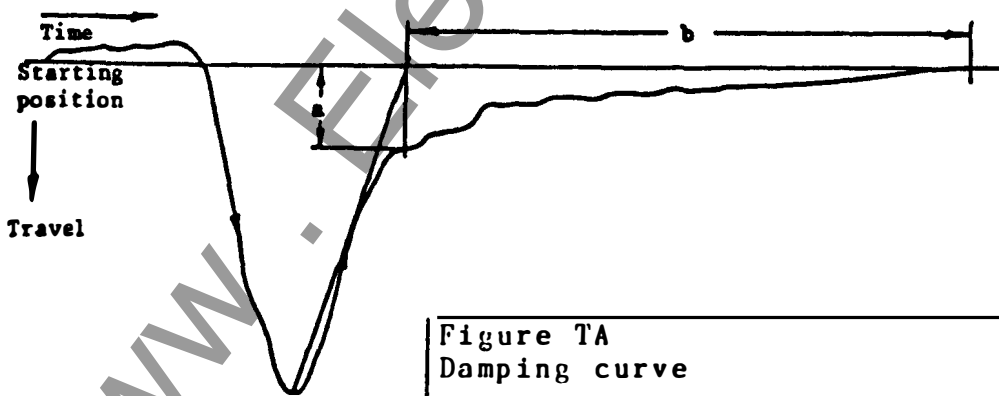
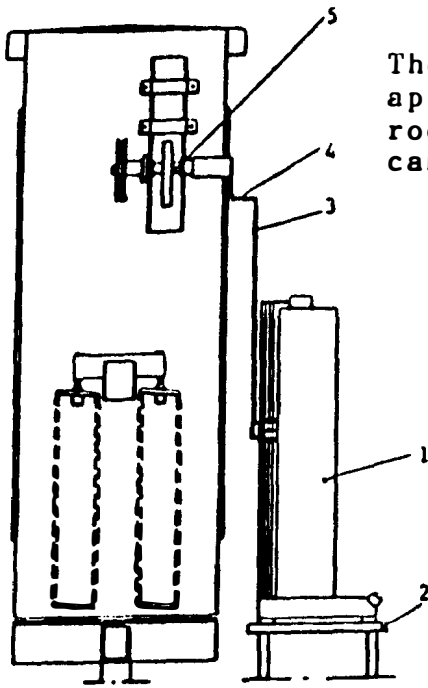

Figure TA
 Damping curve

"a" = damping distance $25/32'' - 1 \ 25/32''$
 "b" = damping time min. 75 ms



The recording drum TB-1 shall be placed on an appropriate table TB-2 and connected with a pull rod TB-3 and an arm TB-4 to the shaft TB-5 of the cam disc.

Figure TB

TB-1	Recording drum
TB-2	Table
TB-3	Pull rod
TB-4	Measuring arm article No. 6909 028-D
TB-5	Shaft for cam disc

Experience from recording the damping curves has given the guiding value $3/16''-25/64''$ for the dimension "c". If there is no possibility of indicating the damping, an acceptable damping can nevertheless be obtained if the guiding value $3/16''-25/64''$ for the dimension "c" is set. A check shall be made of the dimension "c" in the following way:

1. Charge the spring battery with the motor and break the motor- and operating voltage.
2. Press the guide link T-13 forcefully downwards until the piston T-8 is stopped against the cover T-5.
3. Measure the dimension "c".

Adjustment of the dimension "c" shall be carried out as follows:

1. Block the spring bridge as shown in Figure G.
2. Loosen either the lock screw T-3 and turn the piston rod T-4, or loosen the lock screw T-11 and turn the cylinder T-9 in the desired direction. One turn alters the dimension "c" by $5/64''$.

NOTE:

Check that the cylinder T-9 is not threaded so far downwards that the lower threaded end meets the crown wheel on the sprocket T-14 at closing of the operating device.

3. Unblock the spring bridge and charge the closing springs with the motor.
4. Check the dimension "c" again.
5. When the dimension has been adjusted, the dashpot shall be locked with the lock screws T-3 and T-11.

With the bar T-17 the damping intensity of the dashpot can be regulated. The figure shows the placement of the bar at medium damping. If the bar is moved upwards, so that the lower hole is used for fastening, maximum damping will be obtained. If the bar is removed, minimum damping will be obtained.

If the position of the bar is changed or if it is removed, the dimension "c" will also be changed. A corresponding adjustment of the position of the damping cylinder of the piston rod must, therefore, be carried out so that the dimension "c" will be maintained.

If there is any oil leakage around the piston rod T-4, one can suspect damages on one of the O-rings T-6 and T-7. In order to replace these, the oil dashpot must be dismantled from its holders in the following way:

1. Place the operating device in the open position with charged closing springs. Switch off the motor - and operating voltages.
2. Measure the dimensions "a" and "b".
3. Unthread but keep in place the lock screws T-3 and T-11.
4. Place the hand crank in the operating position and discharge the closing springs sufficiently for the blocking arm F-2 to go into the locked position against the interlocking disc F-3. This is done partly to obtain space for the dashpot at dismantling, and partly to block the operating device against unintentional closing operation.
5. Loosen the nuts AE-1 and AE-2 sufficiently for the endless chain to be discharged. Thread the piston rod T-4 and the cylinder T-9 out of their holders and lift out the dashpot.
6. Loosen the cover T-5, which is locked with material which has been pushed into a slot in the cylinder T-9. The O-rings will then be accessible for replacement.

Prior to assembling the dashpot itself a check shall be made that the oil level measured from the upper edge of the cylinder is $2 \frac{3}{8}$ ", as shown in Figure T. Use oil "S". See information 051L05103.

At remounting of the oil dashpot, the piston rod T-4 and the cylinder T-9 shall be threaded into their respective holders, far enough for the values for the dimension "a" and "b", which were measured prior to dismantling, to be maintained.

Adjust the lock washers T-2 and T-12 so that the minimum plays of 2mm are obtained before the lock screws T-3 and T-11 are tightened.

Tighten the nuts AE-1 and AE-2 so that the dimension "X" in figure AE is maintained.

Opening dashpot

The purpose of the opening dashpot is to slow down the opening movement in its final stage. The dashpot is connected to the operating arm U-3 in such a way that clearance is obtained during the first half of the operation.

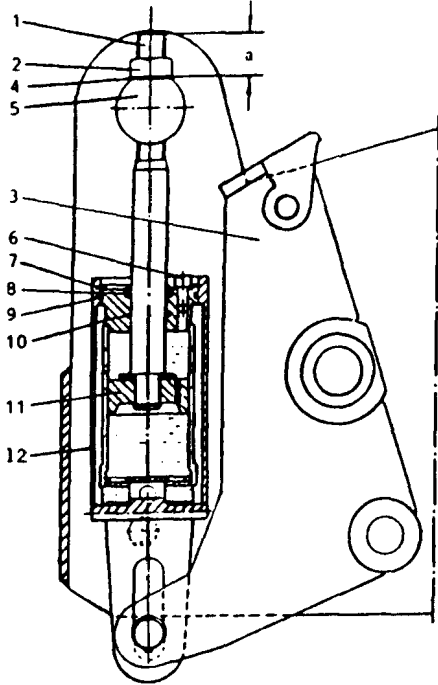

Figure U

U-1	Piston rod with screw thread
U-2	Nut (resp. grub screw)
U-3	Operating arm
U-4	Guide washer
U-5	Bolt
U-6	Oil filling screw
U-7	Retaining ring
U-8	Wiper
U-9	O-ring
U-10	O-ring
U-11	Piston
U-12	Cylinder

At delivery the dashpot is set for correct damping, which means that the dimension "a" on figure U is $1\frac{1}{2} \pm \frac{1}{4}$ ". (Note that the dimension is applicable from the upper end of the piston rod to the upper side of the guide washer on the upper figure).

At any adjustment of the opening damping, which is carried out by means of loosening the nut U-2 and threading the piston rod U-1 downwards for harder damping or upwards for more gentle damping, the dimension "a" shall, even after adjustment, always be within this tolerance zone. After adjustment, the nut resp. grub screw U-2 shall be retightened.

If the dashpot has for some reason been dismantled, care shall be taken at mounting to place the oil filling plug straight in towards the center of the operating mechanism, for best accessibility.

NOTE: filling up with oil in the dashpot shall only be carried out when the circuit-breaker is in the open position. The dashpot shall in that position be entirely full of oil. Use oil "D" See information 051L05103.

Friction coupling

The friction coupling, the position of which can be seen from figure E, shall prevent unpermitted overloading of the mechanism when spring bridge (A-13), after charging of the closing springs, stops against the end stop (A-19) or if the motor current for some reason is not interrupted after the closing springs have been charged. In the latter case, the thermal release of the motor starter will trip after 15-45 seconds.

Caution

The friction coupling shall not be lubricated.

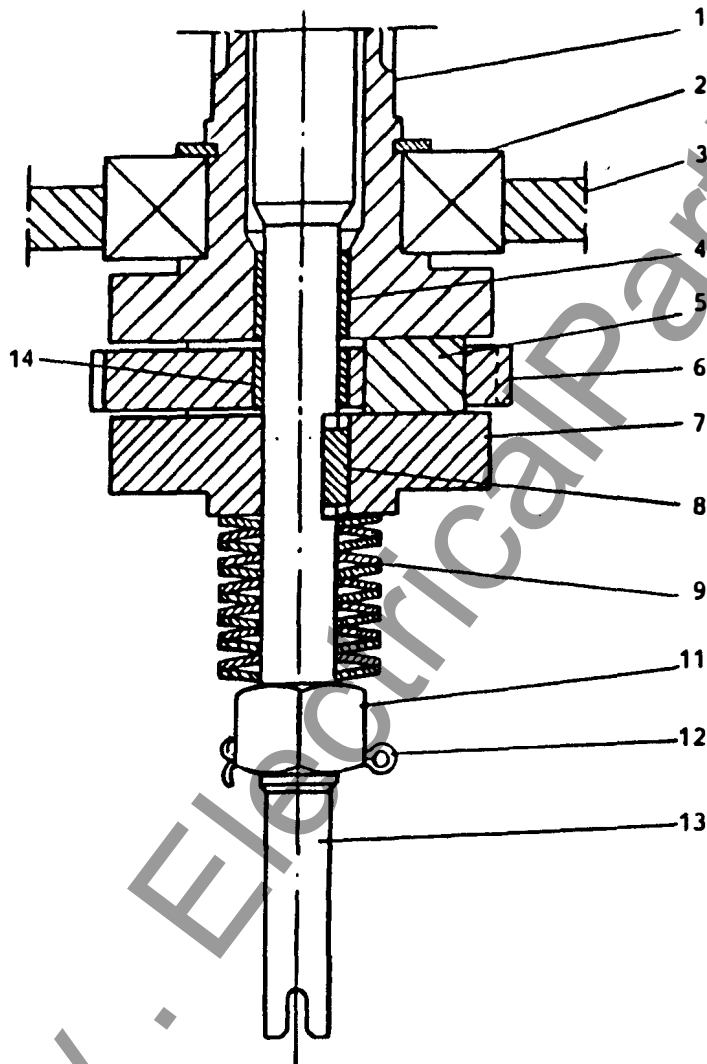

Figure V

V-1	Gear wheel
V-2	Ball bearing
V-3	Gear framework
V-4	Glacier sleeve
V-5	Friction insert
V-6	Ratchet wheel for catch E-6
V-7	Friction disc
V-8	Wedge 4x4x12
V-9	Cup springs
V-11	Nut
V-12	Split pin, 3.2x25
V-13	Shaft
V-14	Glacier sleeve

Three friction inserts V-5 are placed in slots in the ratchet wheel V-6. The necessary frictional force is obtained from the cup springs V-9 which, via the friction disc V-7, press the friction inserts against the end surface of the gear wheel V-1.

Regardless of whether the closing springs are charged with a motor or a hand crank, the driving torque is always transferred from the shaft V-13 via the friction coupling to the gear wheel V-1.

The sliding torque of the friction coupling is adjusted with regard to the force in the closing springs. The sliding torque shall be set in the following way:

The maximum motor current shall be measured during the charging of the spring bridge.

The spring bridge shall be blocked as described on page 13.

Start the motor and measure the motor current.

Adjust the coupling by means of the nut V-11, until the motor current is 1.3-1.5 times the current measured above.

Motor

The motor, which via the gear charges the closing springs, is a single-phase series-wound universal motor in enclosed design.

The standard voltage is 110- or 220 V DC or AC, but other voltages can occur.

Catch device with operating magnets

The operating device is as a standard fitted with one closing magnet and one opening magnet but can on request be fitted with double magnets for both functions.

The standard voltage for the coils of the magnets is normally 110 or 220 V DC or AC but other voltages can occur. The rated power of the coils is approximately 200 W.

The magnets are mounted on the catch device, which are similar in function. Owing to different loads and different fastening methods, the "OFF" side of the catch device deviates slightly from the "ON" side, as can be seen from figures X and Y.

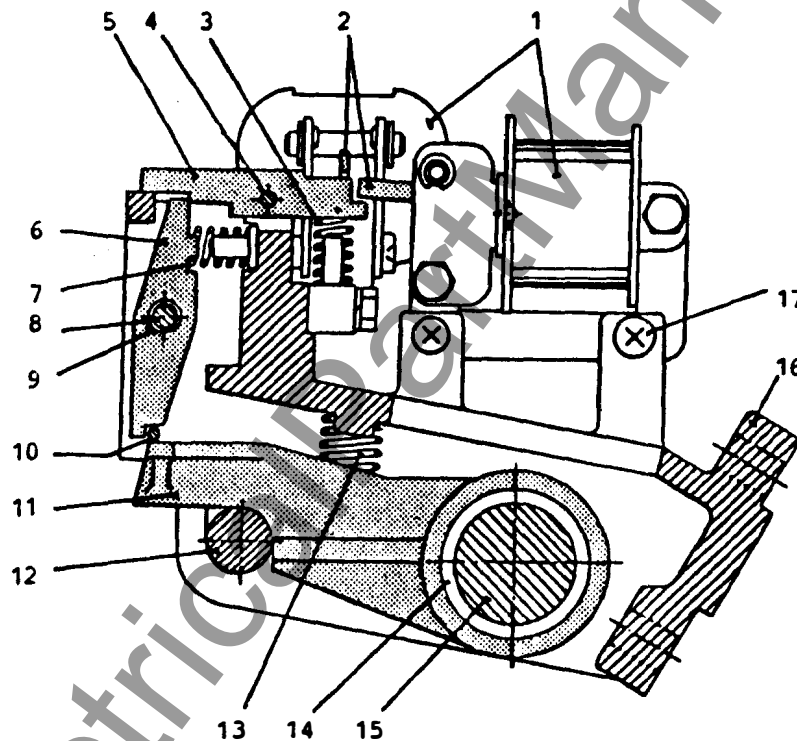

Figure X Catch device for opening

X-1	Magnets. See figure Z	X-10	Roller
X-2	Magnet arm	X-11	Main opening catch
X-3	Spring	X-12	Roller
X-4	Shaft	X-13	Spring
X-5	Auxiliary opening catch	X-14	Needle bearing (two)
X-6	Intermediate catch	X-15	Shaft
X-7	Spring	X-16	Holder
X-8	Shaft	X-17	Screw and self-locking nut
X-9	Needle bearing (two)		

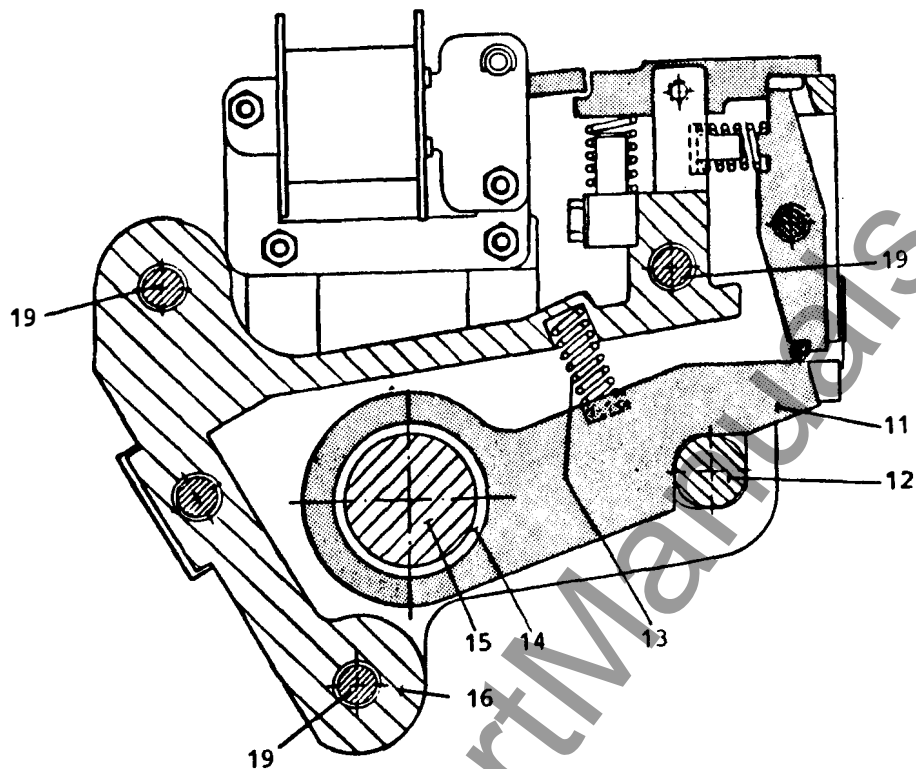

Figure Y Catch device for closing

Y-11	Main closing	Y-15	Shaft
Y-12	Roller	Y-16	Holder
Y-13	Spring	Y-19	Fixing screw M10x70
Y-14	Needle bearing (two)		

The other parts in the catch device are identical with corresponding parts in the catch device according to figure V.

The needle bearings X-9 and X-14 are on delivery greased and normally require no lubrication. The shaft X-4 should, in connection with inspection and overhaul of the operating device, be lubricated with oil B. See information 051L05103.

The catch device requires no setting of the catch positions.

If it should be necessary to perform work on the catch device it must be dismantled whole from the operating device framework. On the catch device for opening, the loop AA-4 of the mechanical tripping device must also be disconnected. This can be most easily done by threading out the nut AA-1.

If it is necessary to replace coils, the magnet shall be dismantled from the catch device.

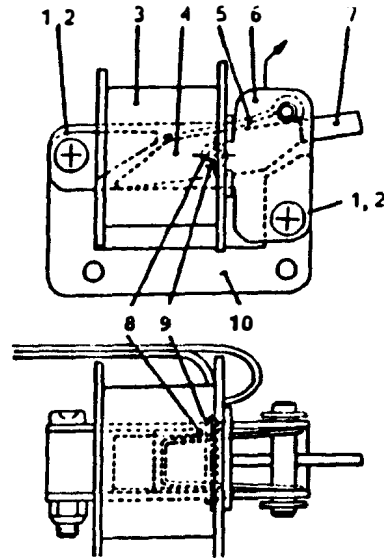
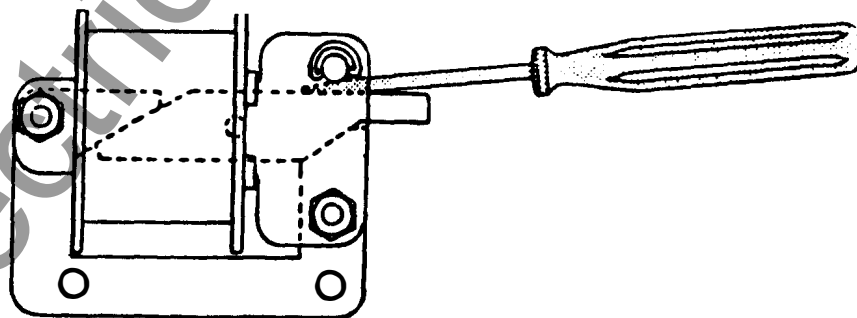

Figure Z Magnet

Z-1	Screw M6x30
Z-2	Self-locking nut
Z-3	Coil
Z-4	Magnet armature
Z-5	Spring
Z-6	Support plates
Z-7	Magnet arm
Z-8	Washer
Z-9	Shaft
Z-10	Magnetic core

Replacement of coils shall be carried out as follows:

1. The nuts Z-2 shall be loosened and the screws Z-1 shall be removed.
2. The support plates Z-6 including the armature and the coil shall be drawn upwards-aside as indicated by the arrow.
3. The coil shall be replaced, the parts shall be returned to their places and the screws Z-1 shall be mounted.
4. Prior to tightening the nuts Z-2 the magnet arm Z-7 shall be pressed forcibly downwards, for instance with a screwdriver as shown in the figure below, so that the air gaps will be as small as possible.



5. The magnet shall be mounted on the catch device. Nominally, a play of approximately 1/32" shall exist between the magnet arm X-2 and the auxiliary opening catch X-5
6. The conductors of the coil shall be connected.
7. Mounting and adjustment of the mechanical tripping device can be seen in the text to figure AB.

Mechanical tripping device

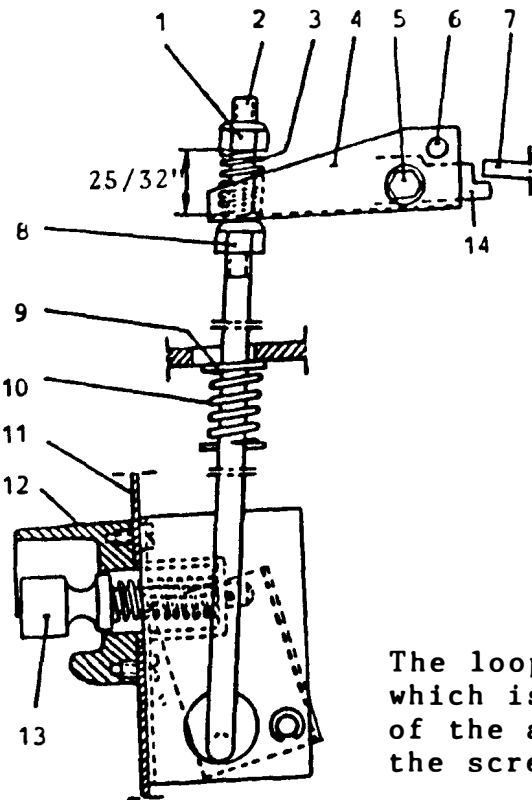

Figure AA

AA-1	Self-locking nut
AA-2	Operating rod
AA-3	Spring
AA-4	Loop
AA-5	Screw M6x30
AA-6	Pin
AA-7	Magnet arm (X-2)
AA-8	Lock nut
AA-9	Washer
AA-10	Spring
AA-11	Operating device cubicle
AA-12	Pushbutton device
AA-13	Pushbutton
AA-14	Auxiliary opening catch

The loop AA-4 is flexible around the screw AA-5, which is threaded into the hole for the shaft X-4 of the auxiliary opening catch. The purpose of the screw is also to hold the shaft X-4 in place.

By means of the nut AA-8 a play, 1 mm, shall be set between the auxiliary opening catch AB-5 (X-5) and the intermediate catch AB-6 (X-6) when the pushbutton AA-13 is pressed in.

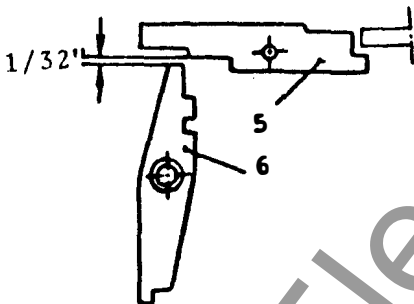

Figure AB

AB-5	Auxiliary opening catch X-5
AB-6	Intermediate catch X-6

By means of the nut AA-1 the spring AA-3 shall be prestressed to 25/32"

Auxiliary contact

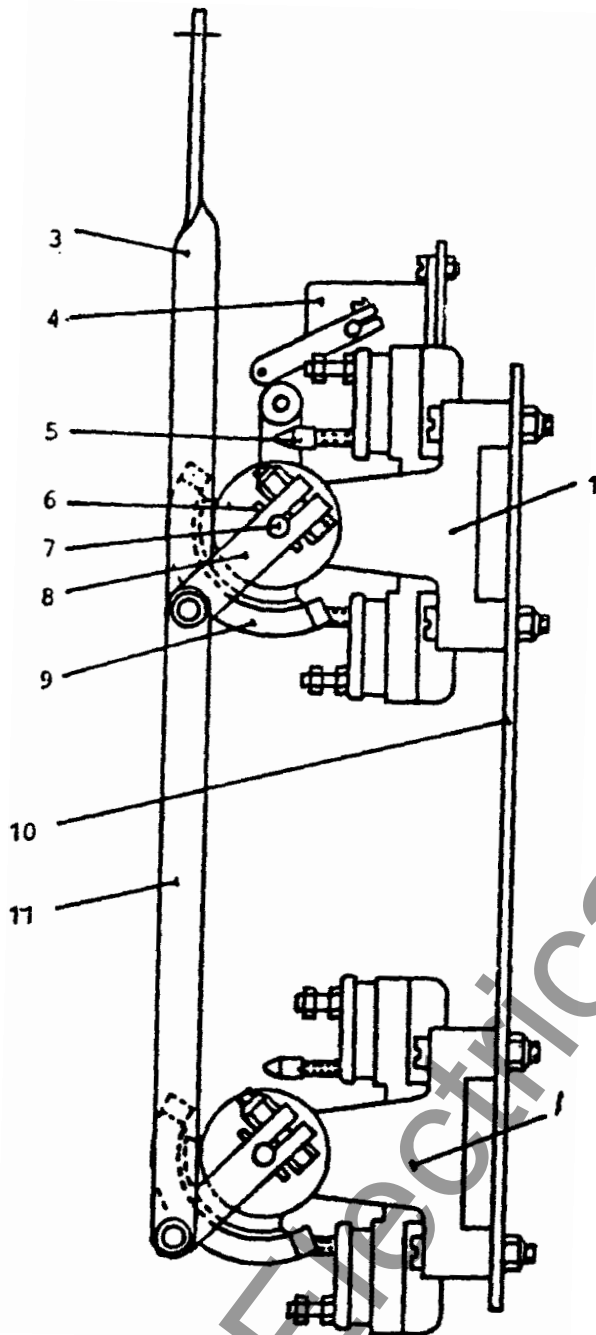

Figure AC

AC-1	6-pole auxiliary contact
AC-3	Operating link
AC-4	Counter
AC-5	Contact pin
AC-6	Roll pin
AC-7	Shaft
AC-8	Operating arm
AC-9	Contact washer
AC-10	Fixing plate
AC-11	Link

The operating device is in standard form fitted with a 2 x 6 pole auxiliary contact AC-1 consisting of 6 break and 6 make contacts, of which one of each is used for the function of the operating device.

The shaft AC-7 of the auxiliary contact is in direct mechanical connection with the operating arm K-9 and thus follows the movements of the circuit-breaker contacts.

Counter

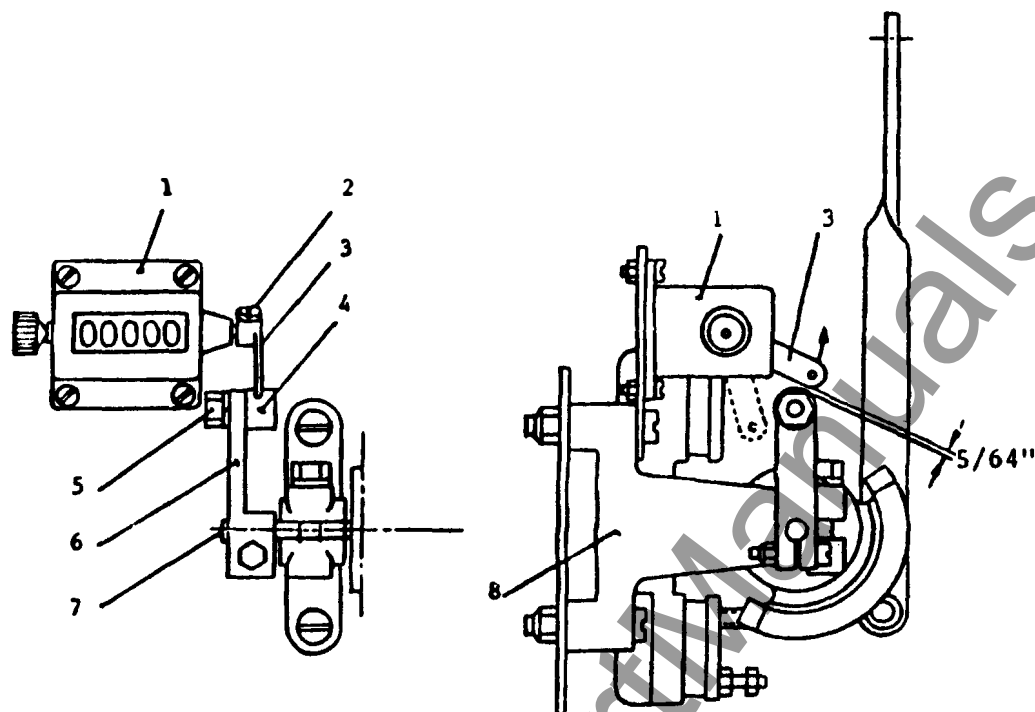

Figure AD			
AD-1	Counter	AD-5	Screw
AD-2	Screw	AD-6	Arm on the auxiliary contact
AD-3	Arm	AD-7	Shaft on the auxiliary contact
AD-4	Cylindrical nut	AD-8	Auxiliary contact

The figure shows the position of the auxiliary contact when the operating device is in the open position.

The spring-loaded arm AD-3 of the counter shall, with the screw AD-2, be adjusted so that when the arm is moved in the direction of the arrow towards its built-in stop, there will be a $5/64$ " play between the arm and the cylindrical nut AD-4.

Buffer for the charging chain

The purpose of the charging chain B-22 is to keep the endless chain B-8 stretched. In order to neutralize the jerks which occur in the charging chain during operation of the operating device, the shaft AE-4 of the deflector wheel has been fitted with two resilient buffers AE-3. The construction and setting dimensions of the buffers can be seen in the figure below. The measure $+1/32 -0$ shall be kept with the mechanism charged with the motor.

5 1/4" with 84" spring washers AE-3 per buffer.

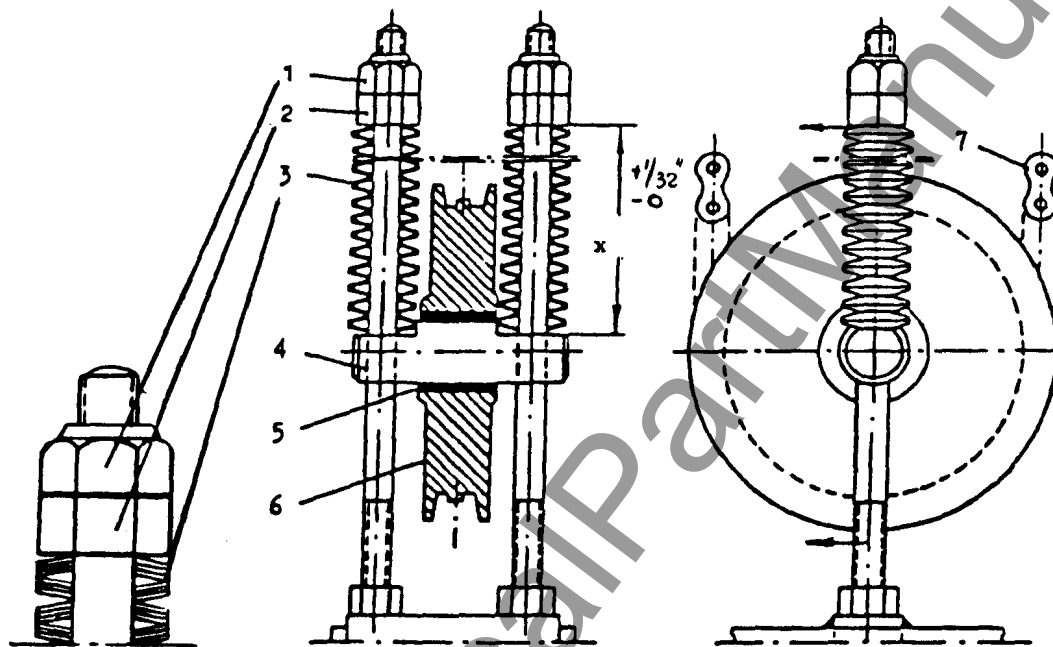

Figure AE			
AE-1	Self-locking nut M12	AE-5	Self-lubricating sleeve
AE-2	Lock nut M12	AE-6	Deflector wheel
AE-3	Spring washers	AE-7	Charging chain
AE-4	Shaft		

Heater

The electric heating is normally obtained from two separate heaters A-4, of which one is intended for continuous heating to avoid condensation of moisture in the operating device cubicle. The other is automatically switched on when the temperature drops below the value set on the thermal relay.

Thermal relay

The temperature should normally be set on 50° F or +10°C on the thermal relay A-12.

Maintenance

Work on the operating device in the closed position and also with charged closing springs involves certain risks. Before the work is begun, the motor starter shall, therefore, be tripped out with the red button P-11 on the control panel. The switch P-5 for operating voltage shall be reset to "LOCAL". In order to set the operating device (circuit-breaker) in the open position with discharged closing springs, the circuit-breaker must first be tripped and then the closing springs shall be discharged by means of a closing operation followed by an opening operation, or manually as described under "Manual charging and discharging of the closing springs".

Cleaning

The operating device shall be cleaned when necessary. Special attention shall then be paid to the terminal blocks and the auxiliary contact.

Lubrication

Lubrication of the bearings in the operating device is not necessary as they are of self-lubricating type or needle- or ball bearing which have been permanently lubricated before delivery.

The gear wheels on the gear shall be sparingly lubricated with grease G after approximately every 500 operations. Great care shall be taken that no grease gets into the friction coupling. In connection with overhaul: The shaft X-4 and the sleeves and sliding surfaces for the spring bridge, dashpot and chains shall be lubricated with oil B.

The trade names for approved lubricants with the above designations are given in Instruction Sheet 051L05103.

SPARE PARTS

Breaker pole for SF6 Breaker type IIPL 362-550/25B2 - 31B2

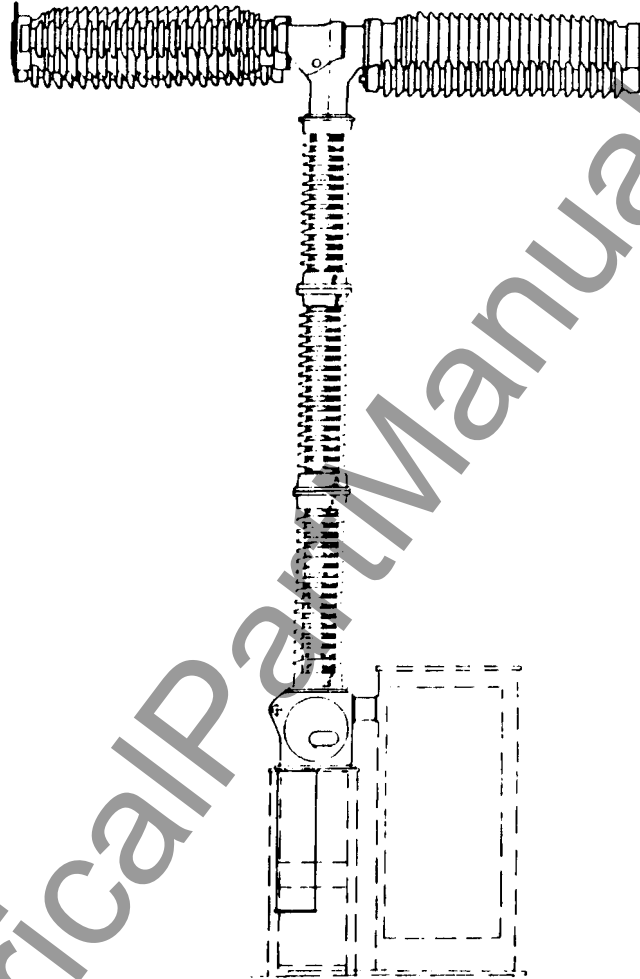

Recommended spare parts are marked

R

For more than 10 breakers in service
we also recommend spare parts marked

RR

www.ElectricalPartManuals.com

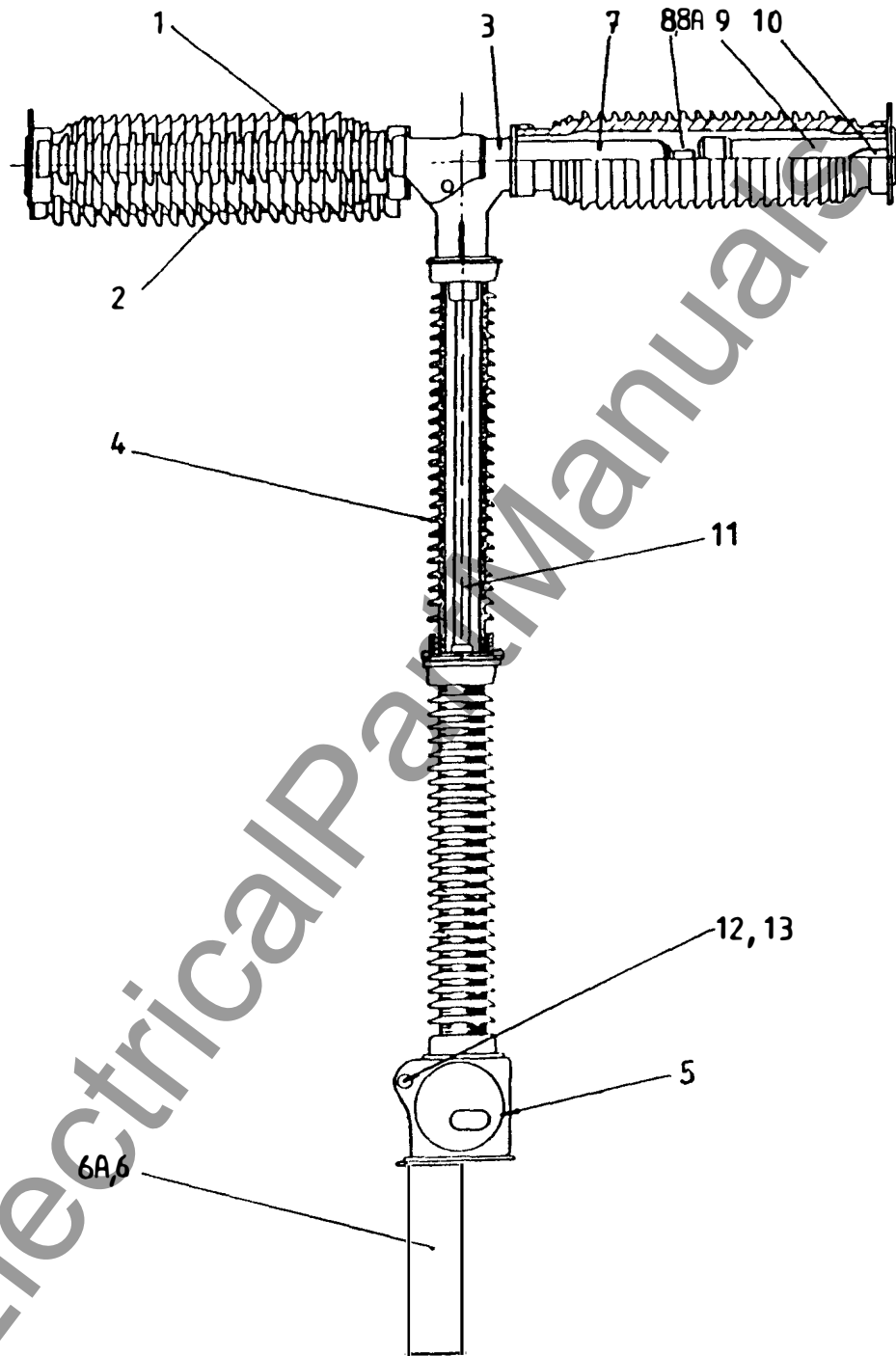

Item No.	Qty.	Name of item	Article No.	Sub List	Note
1	2	Breaking unit	5411 030-M	5	
2	2	Capacitor	1)		RR
3	1	T-mechanism	5421 080-AR	7	
4	1	Postinsulator		9	
5	1	Mechanism	5421 049-BL	13	
6	1	Tripping mechanism	5421 051-AU	15	2)
6A	1	Tripping mechanism	5421 051-BK	15	3)
7	2	Bottom curr. coll.	5413 080-U	17	
8	2	Puffer	5412 046-Y	19	4)
8A	2	Puffer	5412 046-AK	19	5)
9	2	Top curr. coll.	5413 080-X	21	
10	2	Dessic.container	6932 990-A	22	
11	1	Operator insulator		9	
12	1	Density switch		23	
13	1	Non ret. valve	2541 959-B	24	

NOTE Sets of contacts and gaskets see page 25

1)

Color	Brown	Grey
Capacitance	1600pf +5 0%	1600pf +5 0%
Creepage distance	5250 mm	5250 mm
Capacitor length	1830 mm	1830 mm
Condensator	5417 029-10	5417 029-15
Article number	5439 133-H	5439 133-M

- 2) Old design
- 3) New design
- 4) 40 kA
- 5) 50 kA

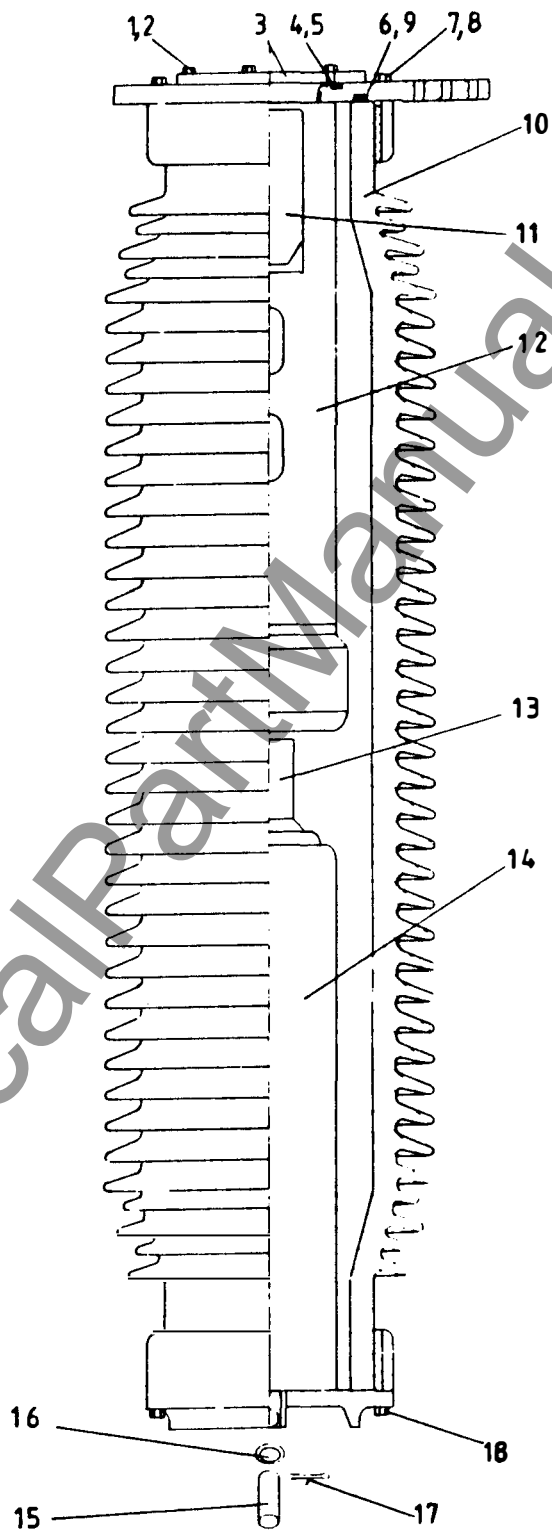

Breaking unit 5411 030-M

Item No.	Qty.	Name of item	Article No.	Sub List	Note
1	6	Hex. head bolt	2121 2017-493		
2	6	Washer	2151 2063-173		
3	1	Cover	5237 730-21		
4	1	O-ring	2152 930-195		R
5	1	O-ring	2152 930-210		R
6	2	O-ring	2152 930-280		R
7	8	Hex. head bolt	2121 2017-532		
8	16	Washer	2151 2063-179		
9	2	O-ring	2152 930-290		R
10	1	Chamber ins.	1)		RR
11	1	Dessic. container	6932 990-A	20	
12	1	Top current coll.	5413 080-X	19	
13	1	Puffer	5412 046-Y	17	
14	1	Bottom curr. coll.	5413 080-U	15	
15	1	Parallel pin	2111 760-27		
16	2	Washer	2151 2092-102		
17	2	Split pin	2114 2050-199		
18	8	Hex. head bolt	2121 2017-530		

1)

Color	Creepage distance	Isolator height	Article number
Brown	5530 mm	1904 mm	2732 1909-R
Light-grey	5530 mm	1904 mm	2732 1909-S

T-Mechanism

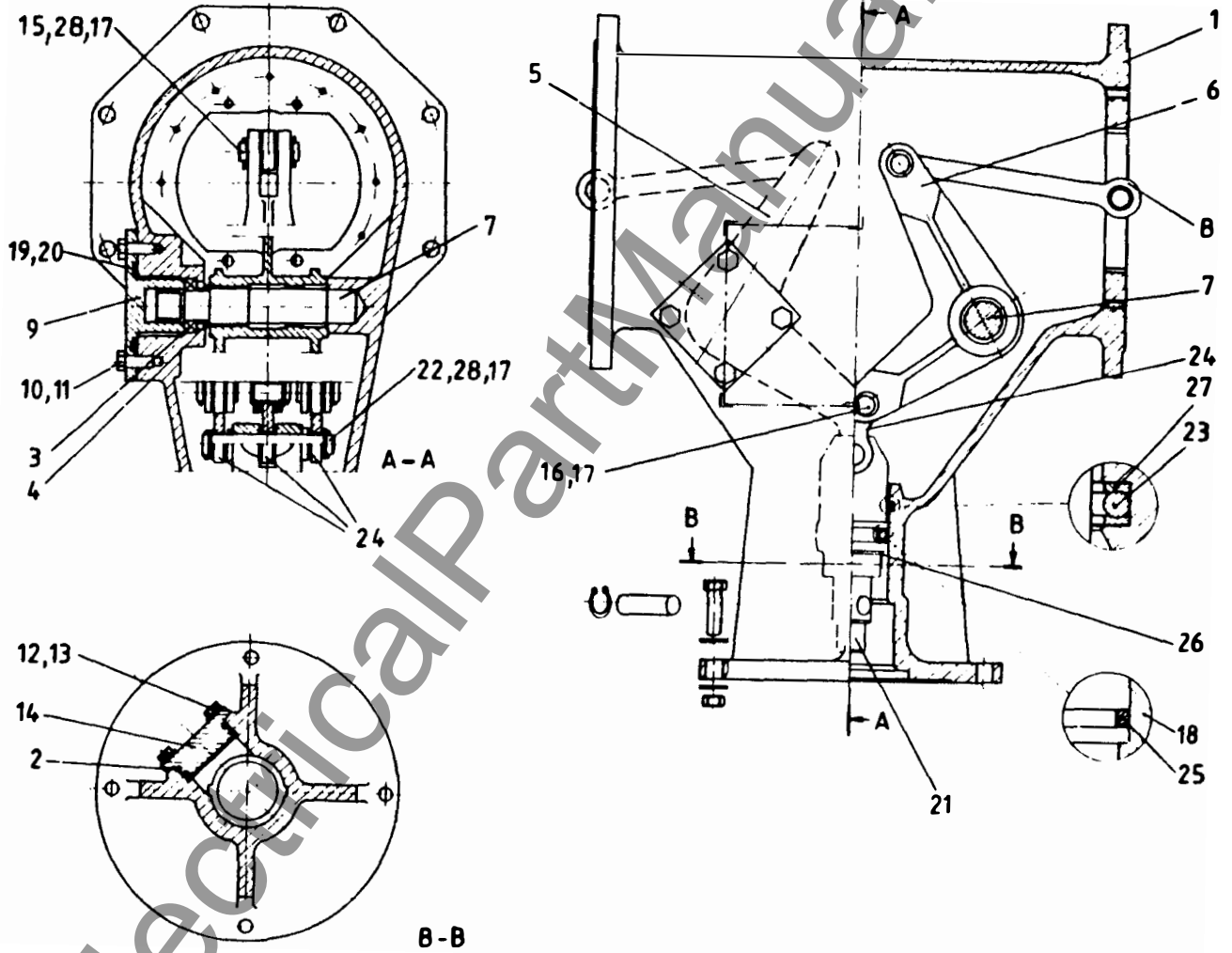

051L05113
 PAGE 7
 GBG 7-18-88

T-Mechanism 5421 080-AR

Item No.	Qty.	Name of item	Article No.	Note
1	1	Mechanism housing	5422 113-AD	
2	2	O-ring	2152 930-70	R
3	2	Ball bearing	2213 6001-106	
4	2	Spacer	2151 891-6	
5	1	Operating lever	2184 4113-BB	
6	1	Operating lever	2184 4113-AY	
7	2	Shaft	2234 159-11	
8	2	Link	2184 4346-D	
9	2	Cover	2172 805-160	
10	8	Hex. head bolt	2121 2017-526	
11	8	Washer	2151 2063-179	
12	4	Hex. head bolt	2121 2017-492	
13	4	Washer	2151 2063-173	
14	1	Cover	2172 805-102	
15	2	Parallel pin	2111 760-27	
16	3	Clevis	2116 729-21	
17	9	Split pin	2114 2050-216	
18	1	Bushing	2211 861-4	
19	2	O-ring	2152 930-90	
20	2	O-ring	2152 930-85	
21	1	Operating rod	2184 4059-8	
22	1	Parallel pin	2111 760-24	
23	1	O-ring	2152 939-34	R
24	3	Link	2184 4346-F	
25	1	O-ring	2152 930-65	R
26	1	Retaining ring	2154 753-4	
27	2	Support ring	2211 862-3	
28	12	Washer	2151 2092-102	

Post Insulator

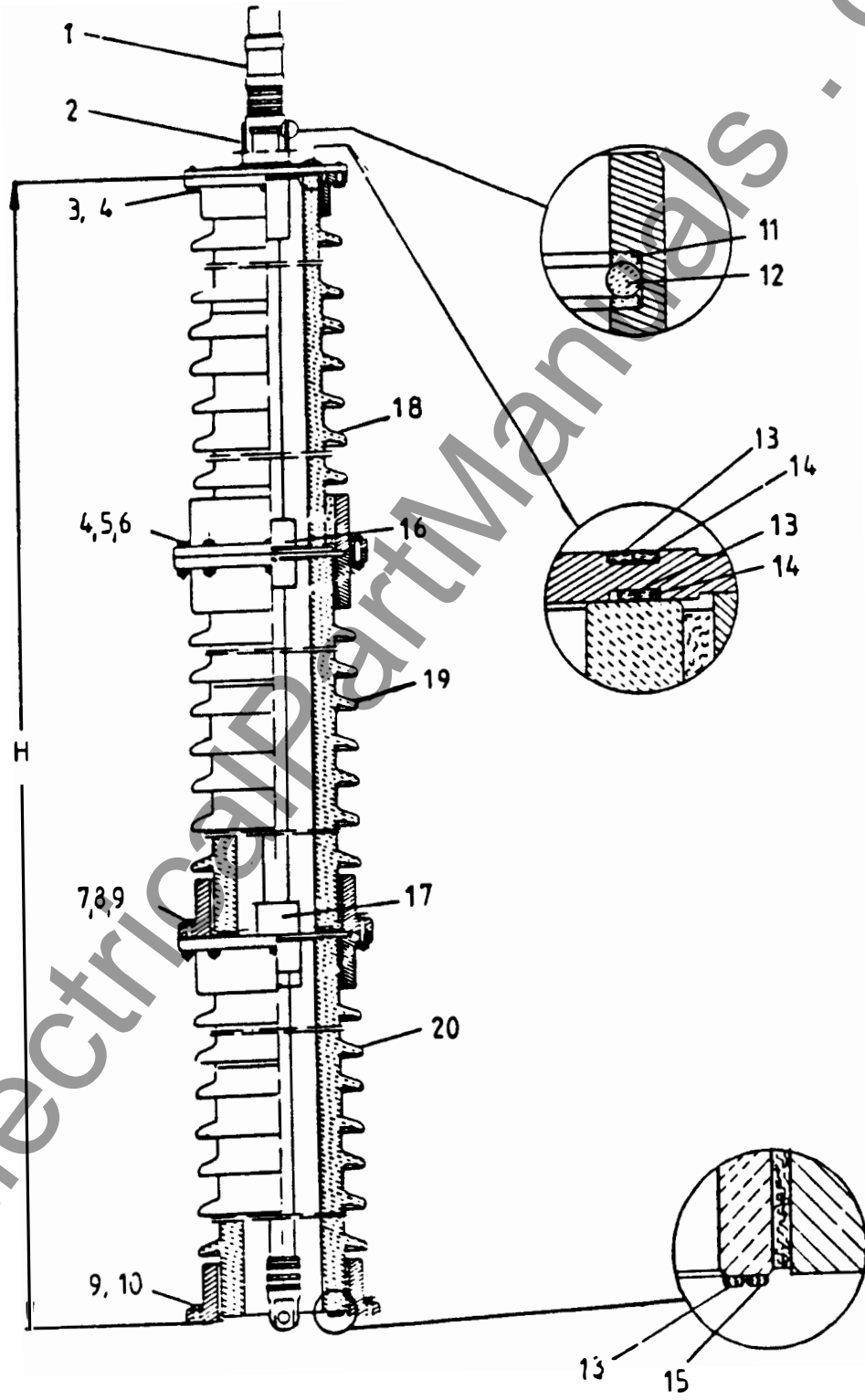

Post insulator

Item No.	Qty.	Name of item	Article No.	Note
1	1	Operating insulator	2184 4349-V	1
2	1	Guide	2186 705-4	
3	4	Hex. head bolt	2121 2017-526	
4	12	Washer	2151 2063-179	
5	8	Hex. head bolt	2121 2017-532	
6	8	Nut	2126 2013-122	
7	8	Hex. head bolt	2121 2017-599	
8	8	Nut	2126 2013-124	
9	16	Washer	2151 2063-185	
10	8	Hex. head bolt	2121 2017-597	
11	2	Support ring	2211 862-3	
12	1	O-ring	2152 939-34	R
13	3	O-ring	2152 930-170	R
14	2	O-ring	2152 930-180	R
15	1	O-ring	2152 930-195	R
16	1	Guide	2185 997-D	2
17	1	Guide	2185 997-E	2

Type HPL	H mm	Creepage mm	C F	Insulators RR		
				Article No for item		
				18	19	20
362 kV LIWL 1175 kV	3060	6375	B	2732 2062- 1	2732 2105- 1	
		6375	G	2732 2062- 5	2732 2105- 5	
		6750	B	2732 2062-20	2732 2105- 1	
		6750	G	2732 2062-25	2732 2105- 5	
		8385	B	2732 2062-10	2732 2105-10	
		8385	G	2732 2065-15	2732 2105-15	
420 kV LIWL 1425 kV	3300	6935	B	2732 2099- 1	2732 2105- 1	
		6935	G	2732 2099- 5	2732 2105- 5	
		9235	B	2732 2099-10	2732 2105-10	
		9235	G	2732 2099-15	2732 2105-15	
420 kV LIWL 1425 kV	3500	6815	B	2732 2064- 1	2732 2065- 1	2732 2066- 1
		6815	G	2732 2064- 5	2732 2065- 5	2732 2066- 5
		9130	B	2732 2064-10	2732 2065-10	2732 2066- 10
		9130	G	2732 2064-15	2732 2065-15	2732 2066- 15

Color B=Brown G=Grey

1) When ordering operating insulator please give the serial number for the C, B.

2) See page 21

5409 724-8

PAGE 9

LBK 85-05-15

Guide

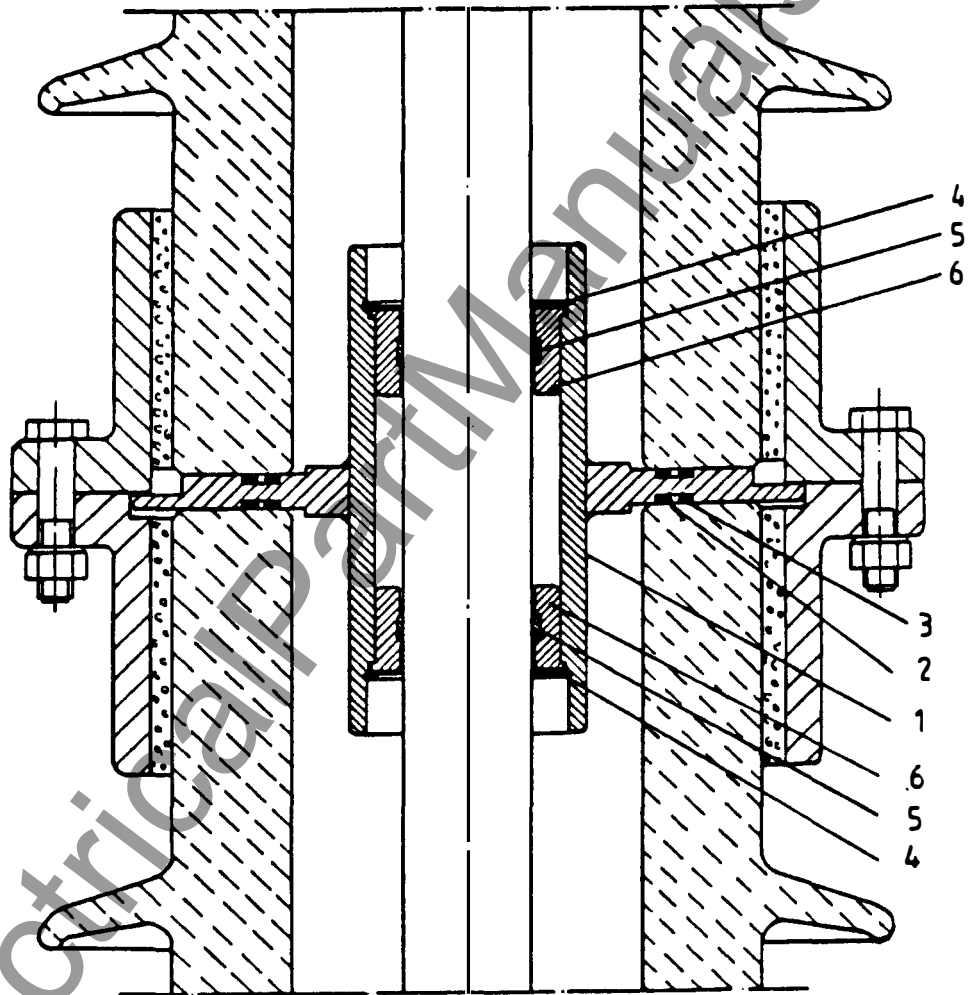

Guide 2185 997-D

Item No.	Qty.	Name of item	Article No.	Note
1	1	Flange	2186 705-8	
2	2	O-ring	2152 930-170	R
3	2	O-ring	2152 930-180	R
4	2	Retaining ring	2154 2527-156	
5	2	Strip	2211 862-1	
6	4	Bushing	2185 884-8	

Guide 2185 997-E

Item No.	Qty.	Name of item	Article No.	Note
1	1	Flange	2186 705-9	
2	2	O-ring	2152 930-170	R
3	2	O-ring	2152 930-180	R
4	2	Retaining ring	2154 2527-156	
5	2	Strip	2211 862-1	
6	4	Bushing	2185 884-8	

Mechanism

051L05113
PAGE 12
GBG 7-18-88

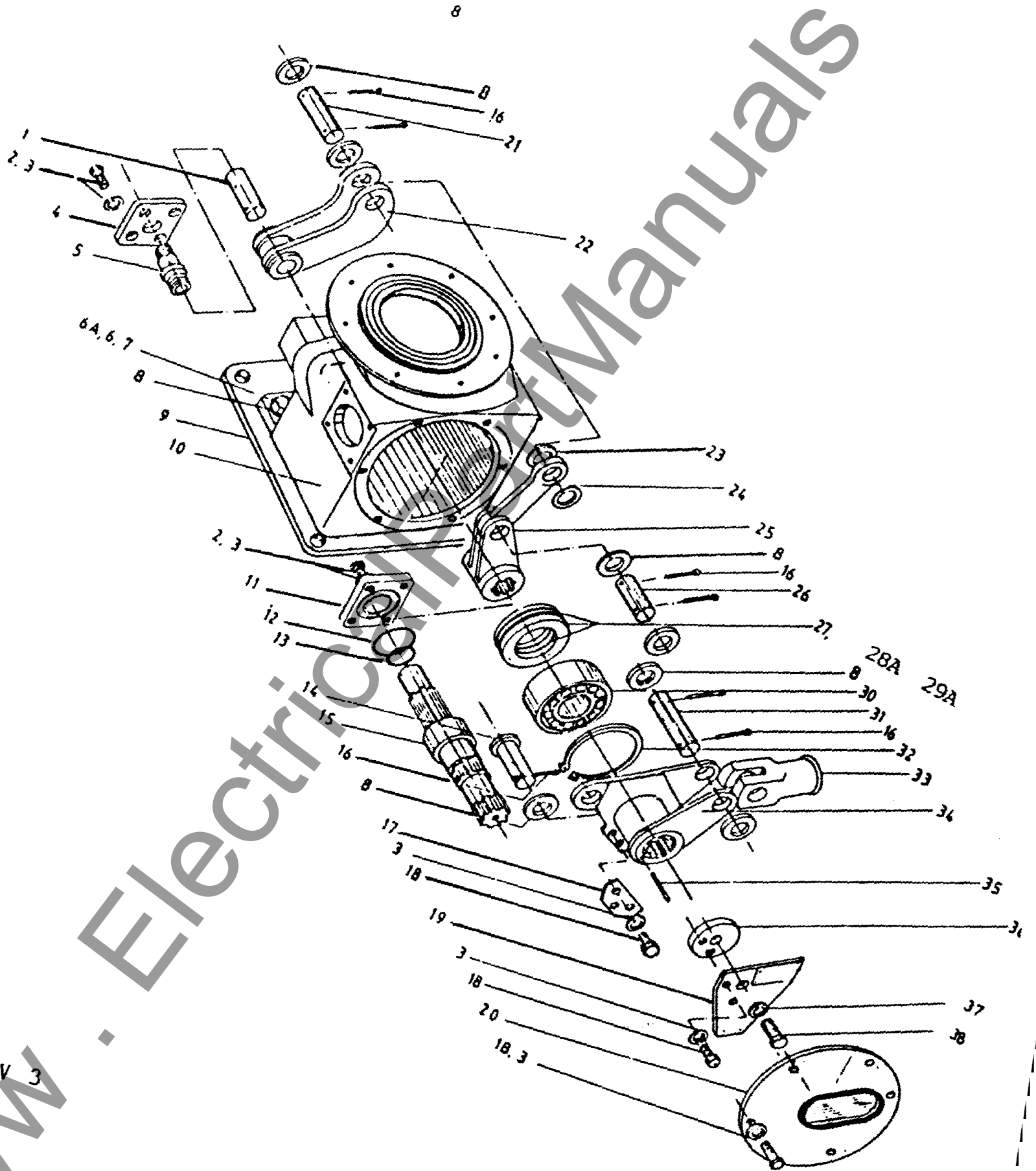

409 724-8 REV 3
PAGE 12
K 86-06-13

Mechanism 5421 049-BL

Item No.	Qty.	Name of item	Article No.	Note
1	1	Parallel pin	2111 805-27	
2	8	Hex. head bolt	2121 2033-414	
3	18	Washer	2151 2064-165	
4	1	Cover	2521 837-2	
5	1	Non ret. valve	2541 959-B	1)
6	3	Hex. head bolt	2121 2017-666	
6A	1	Hex. head bolt	2121 2017-660	
7	3	Hex. nut	2126 2013-126	
8	11	Washer	2151 2075-192	
9	1	Plate	2173 798-47	
10	1	Mechanism housing	5422 113-U	
11	1	Cover	2172 805-109	
12	1	O-ring	2152 930-60	R
13	1	O-ring	2152 930-55	R
14	1	Clevis pin	2116 729-12	
15	1	Shaft	2234 206-M	
16	7	Split pin	2114 2050-216	
17	1	Plate	2173 798-48	
18	4	Hex. head bolt	2121 2033-408	
19	1	Mounting plate	2174 935-1	
20	1	Cover plate	5237 735-A	
21	1	Parallel pin	2111 847-3	
22	1	Support lever	2184 4113-AD	
23	4	Washer	2151 2096-62	
24	1	Link	2184 4346-A	
25	1	Operating lever	2184 4112-30	
26	1	Parallel pin	2111 847-4	
27	1	Bushing	2185 967-6	
28	2	O-ring 0=3,0	2152 999-1	R
29	2	O-ring 0=3,0	2152 999-2	R
28A	2	O-ring 0=5,7	2152 999-3	R \4)
29A	2	O-ring 0=5,7	2152 999-4	R /
30	1	Bearing	2213 6650-312	
31	1	Parallel pin	2111 847-5	
32	1	Retaining ring	2154 2527-173	
33	1	Clevis coupling	2184 903-K	
34	1	Operating lever	2184 4112-40	2)
34A	1	Operating lever	2184 4112-57	3)
35	1	Roll pin	2111 2840-210	
36	1	Washer	2151 793-9	
37	1	Washer	2151 2063-179	
38	1	Hex. head bolt	2121 2017-528	

1) Sublist page 23

2) Old design

3) New design

4) O-ring 28A, 29A for breaker delivered from Sept. 86

Tripping mechanism

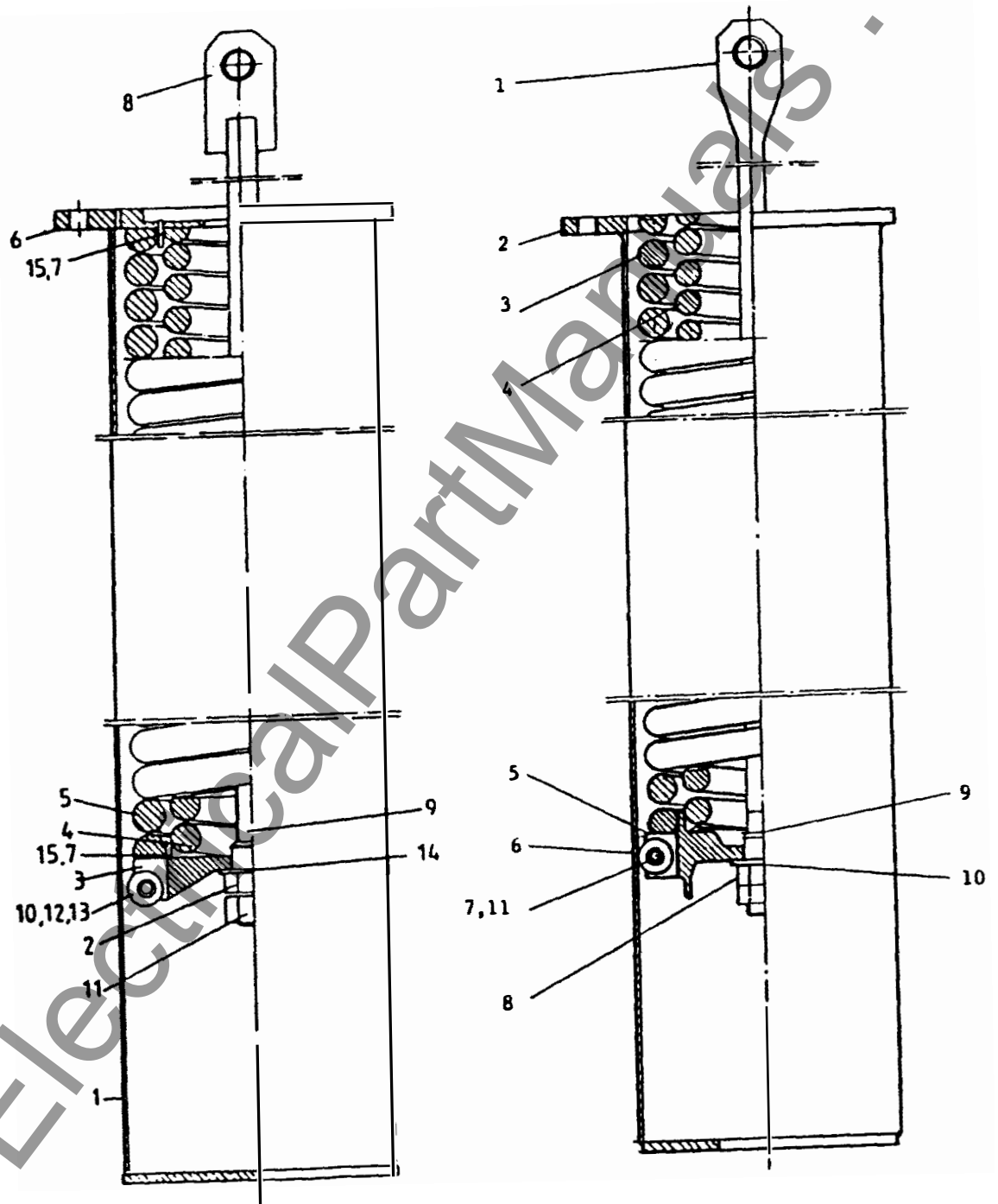

5421 051-AU

5421 051-BK

Tripping mechanism 5421 051-AU 1)

Item No.	Qty.	Name of item	Article No.	Note
1	1	Spring housing	2162 740-II	
2	1	Nut	2125 738-17	
3	1	Spring bracket	2171 738-18	
4	1	Spring	2192 733-5	
5	1	Spring	2192 733-6	
6	1	Plate	2151 866-4	
7	9	Roll pin	2111 2840-310	
8	1	Pull rod	2184 903-V	
9	1	Retaining ring	2154 2526-130	
10	3	Wheel	2292 986-B	
11	1	Lock nut	2126 0072-A	
12	3	Parallel pin	2111 2365-462	
13	6	Split pin	2114 2050-181	
14	1	Washer	2151 2063-204	
15	9	Roll pin	2111 2835-212	

Tripping mechanism 5421 051-BK 2)

Item No.	Qty.	Name of item	Article No.	Note
1	1	Pull rod	2184 938-AT	
2	1	Spring housing	2162 740-AF	
3	1	Spring	2192 733-5	
4	1	Spring	2192 733-6	
5	1	Spring holder	2171 738-33	
6	3	Wheel	2292 986-B	
7	3	Parallel pin	2111 2365-462	
8	1	Lock nut	2126 0072-C	
9	1	Retaining ring	2154 2526-130	
10	1	Washer	2151 2063-204	
11	3	Split pin	2114 2050-181	

- 1) Old design
- 2) New design

Bottom current collector

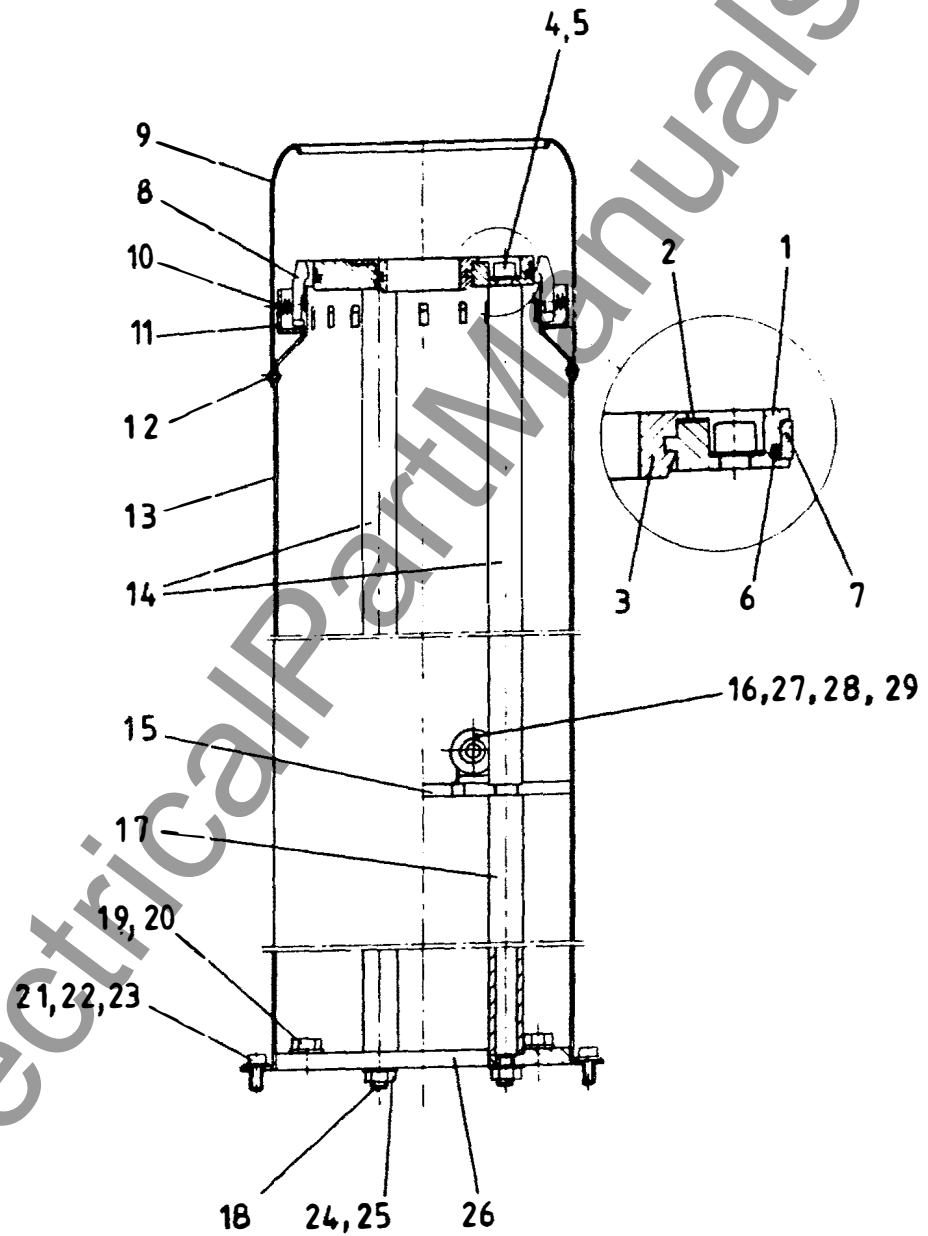

Bottom current collector 5413 080-U

Item No.	Qty.	Name of item	Article No.	Note
1	1	Piston	6532 007-6	
2	1	Washer	2151 883-26	R
3	1	Guide ring	2153 869-7	R
4	3	Spring washer	2154 2031-9	
5	3	Screw M8 x 25	2121 2518-453	
6	1	O-ring	2152 930-140	R
7	1	Stripe	2186 711-4	R
8	28	Contact finger	2658 4059-22	R
9	1	Shield	2748 654-87	
10	28	Spring	2192 749-2	R
11	1	Support ring	2658 4068-16	
12	4	Pop rivet	2115 714-1	
13	1	Current collector	5210 705-9	
14	3	Spacer	2151 846-13	
15	1	Guide disc	2173 731-52	
16	2	Roller	2116 781-C	R
17	3	Spacer	2151 846-11	
18	3	Pin	2111 860-5	
19	4	Screw M10 x 30	2121 2017-493	
20	4	Washer	2151 2063-173	
21	12	Screw M8 x 20	2121 2518-451	
22	12	Spring washer	2154 2031-9	
23	12	Washer	2151 892-7	
24	3	Nut	2126 2028-120	
25	3	Washer	2154 2031-10	
26	1	Washer	2171 738-31	
27	2	Parallel pin	2111 2365-473	
28	4	Washer	2151 2064-173	
29	4	Split pin	2114 2050-181	

Puffer

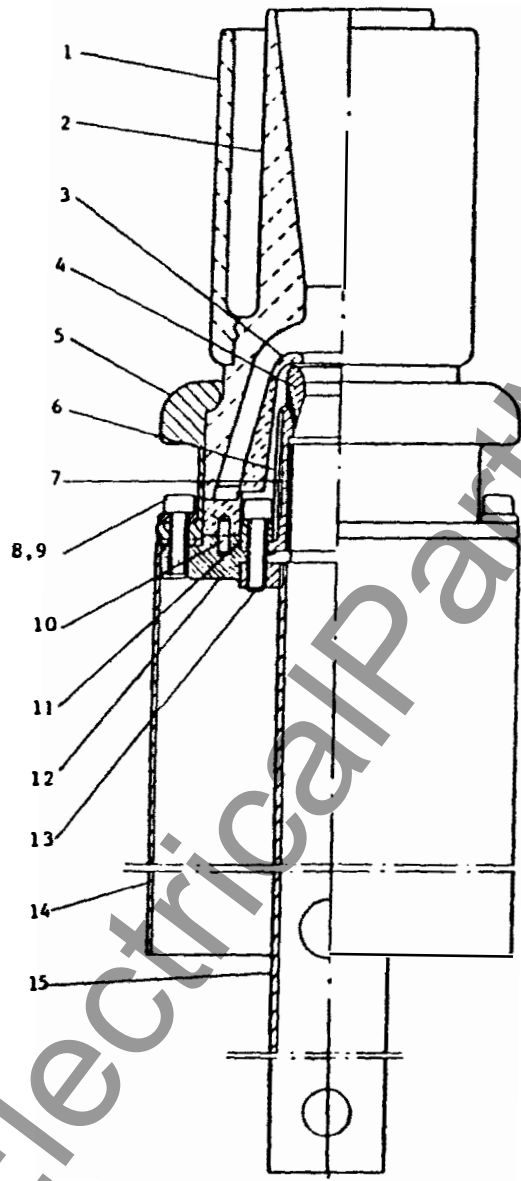

40 kA 5412 046-Y

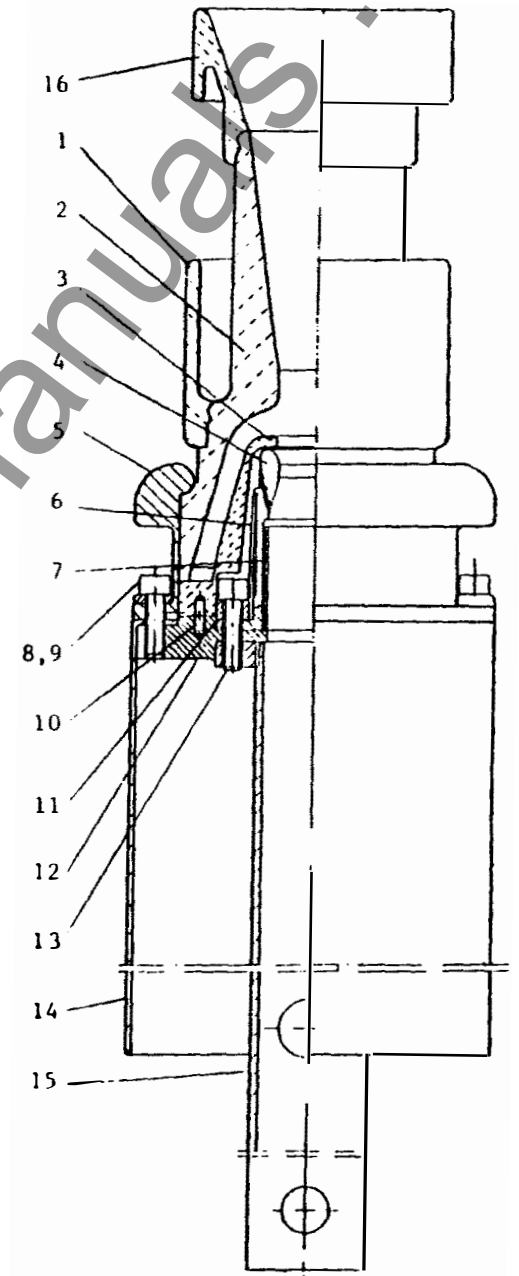

50 kA 5412 046-AK

Puffer 5412 046-Y

Item No.	Qty.	Name of item	Article No.	Note
1	1	Tube	5414 096-2	R
2	1	Nozzle	5414 095-6	R
3	1	Sleeve	5414 090-9	R
4	1	Contact	2658 4110-F	R
5	1	Contact	6531 239-25	
6	12	Spring	2191 731-8	R
7	1	Tube	2171 844-24	R
8	8	Socket screw	2121 2518-453	
9	8	Washer	2151 892-7	
10	1	Roll pin	2111 2835-252	
11	1	Ring	2151 928-9	R
12	1	Holding ring	2171 852-D	
13	6	Socket screw	2121 2518-455	
14	1	Puffer cylinder	2611 800-16	
15	1	Pull rod	2179 714-AP	

Note Contact - 5 is mounted on nozzle - 2 before pressing tube - 1 on the nozzle - 2

Puffer 5412 046-AK

Item No.	Qty.	Name of item	Article No.	Note
1	1	Tube	5414 096-4	R
2	1	Nozzle	5414 095-8	R
3	1	Sleeve	5414 090-9	R
4	1	Contact	2658 4110-F	R
5	1	Contact	6531 239-25	
6	12	Spring	2191 731-8	R
7	1	Tube	2171 844-24	R
8	8	Socket screw	2121 2518-453	
9	8	Washer	2151 892-7	
10	1	Roll pin	2111 2835-252	
11	1	Ring	2151 928-9	R
12	1	Holding ring	2171 852-D	
13	6	Socket screw	2121 2518-455	
14	1	Puffer cylinder	2611 800-16	
15	1	Pull rod	2179 714-AP	
16	1	Collar	5414 096-5	R

Note: Contact - 5 is mounted on nozzle - 2 before pressing tube - 1 and collar - 16 on the nozzle - 2

Top current collector

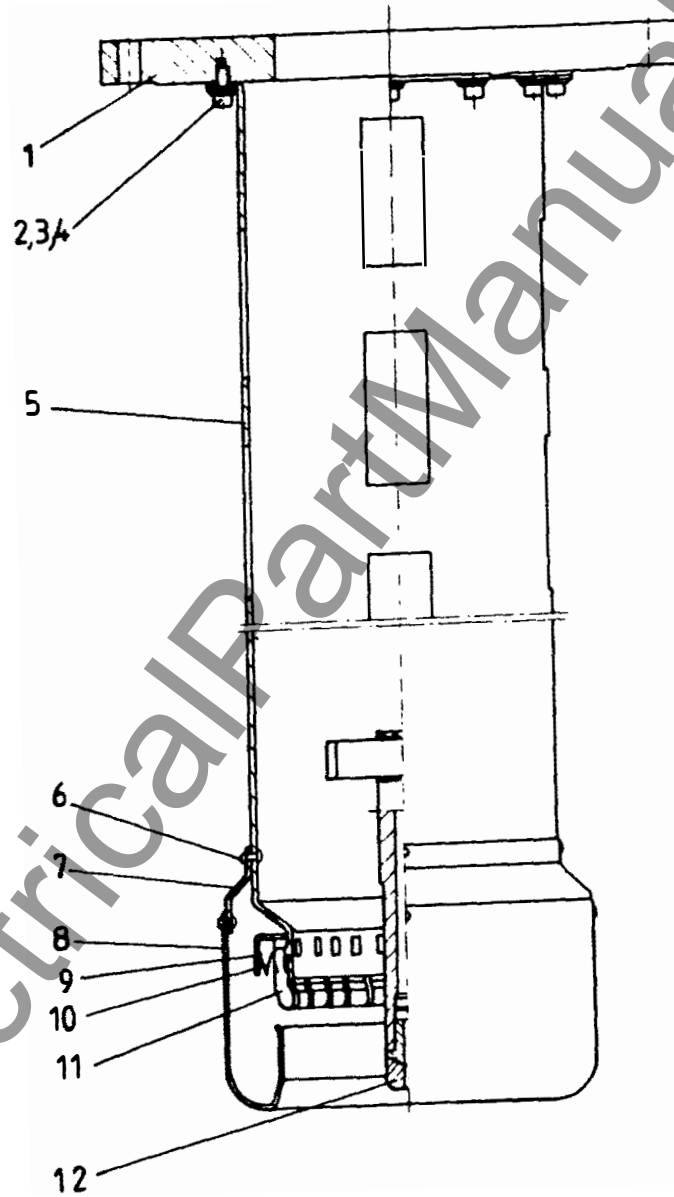

Top current collector 5413 080-X

Item No.	Qty.	Name of item	Article No.	Note
1	1	Flange	5413 072-19	
2	12	Washer	2151 892-7	
3	12	Spring washer	2154 2031-9	
4	12	Socket screw	2121 2518-451	
5	1	Current collector	5210 701-S	
6	8	Pop rivet	2115 714-1	
7	1	Holder	5210 700-1	
8	1	Shield	2748 654-78	
9	1	Support ring	2658 4068-16	
10	28	Spring	2192 749-2	R
11	28	Contact finger	2658 4059-22	R
12	1	Contact tip	2658 974-M	R

Desiccant container 6932 990-A

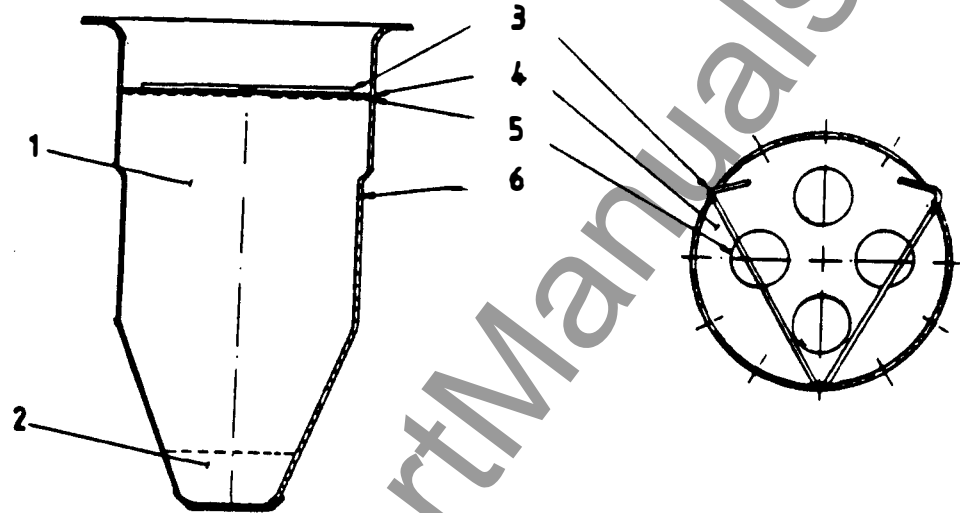

Item No.	Qty.	Name of item	Article No.	Note
1		Alumina	1139 6011-103	2 kg R
2		Molecular sieve	1139 6011-102	0.1 kgR
3	1	Lockspring	2154 4006-1	
4	1	Cover	2531 957-1	
5	1	Net	2591 720-1	
6	1	Container	6932 607-3	

Complete activated desiccant container packed in plastic bag in a pot has article number 6932 990-C (R)

Density switch

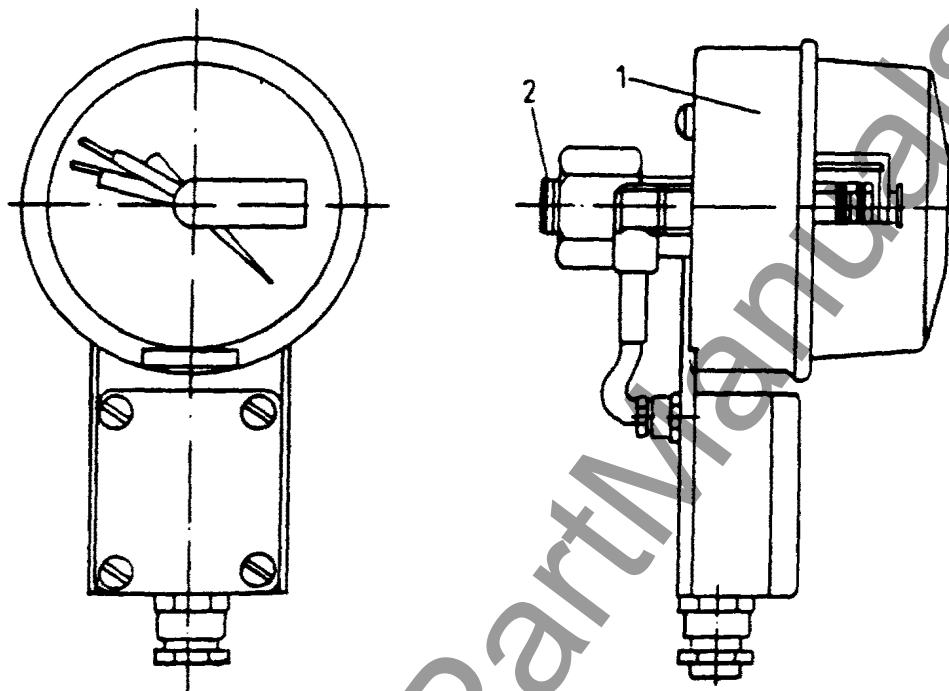

Item No.	Qty.	Name of item	Article No.	Note
1	1	Density switch	see table below	R
2	2	O-ring	2152 929-20	R

Alarm Level PSI abs	Blocking level		Graduated PSI abs	Article No.	Note
	1 PSI abs	2 PSI abs			
65		62	x x	5663 118-49	

Non return valve 2541 959-B

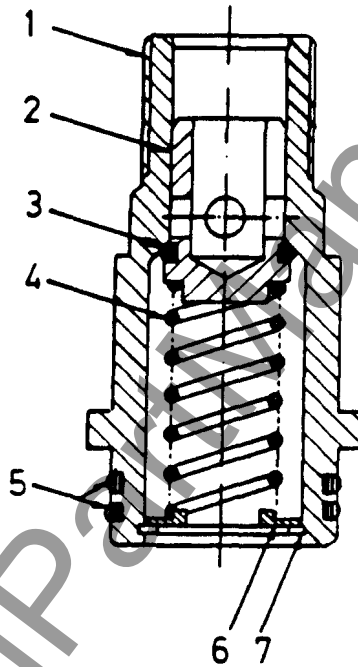

Item No.	Qty.	Name of item	Article No.	Note
1	1	Valve body	2541 960-1	
2	1	Valve cone	2541 961-1	
3	1	O-ring	2152 929-22	R
4	1	Comp. spring	2192 2011-546	
5	2	O-ring	2152 929-40	R
6	1	Support ring	2151 869-13	
7	1	Retaining ring	2154 2527-124	

Set of contact for 1 breaking unit

Article number 5429 038-P R 40 kA
 Article number 5429 038-X R 50 kA

Note For 1 T-unit 2 sets are required

Name of item	Qty.	Article No.	
Contact tip	1	2658 974-M	
Contact finger	56	2658 4059-22	
Spring	56	2192 749-2	\
Contact	1	2658 4110-F	Assembled
Spring	12	2191 731-8	Article No.
Ring	1	2151 928-9	2658 4094-G
Tube	1	2171 844-24	/
Sleeve	1	5414 090-9	
Nozzle	1	5414 095-6	\ only for 40 kA
Tube	1	5414 096-2	/
Nozzle	1	5414 095-8	\
Tube	1	5414 096-4	/
Collar	1	5414 096-5	/ only for 50 kA

Set of gaskets for 1 breaker pole

Article Number 5429 038-R R

Name of item	Qty.	Article No.	Dimension
O-ring	2	2152 929-20	15, 3 x 2, 4
	1	2152 929-22	17, 3 x 2, 4
	2	2152 929-40	34, 2 x 3
	1	2152 930-55	49, 5 x 3
	1	2152 930-60	54, 5 x 3
	2	2152 930-65	59, 5 x 3
	4	2152 930-70	64, 5 x 3
	2	2152 999-1	69, 5 x 3
	2	2152 930-90	84, 5 x 3
	2	2152 999-2	94, 5 x 3
	2	2152 930-140	134, 5 x 3
	7	2152 930-170	159, 3 x 5, 7
	6	2152 930-180	169, 3 x 5, 7
	2	2152 930-85	79, 5 x 3
	3	2152 930-195	184, 3 x 5, 7
	2	2152 930-210	199, 3 x 5, 7
	4	2152 930-280	269, 3 x 5, 7
	4	2152 930-290	279, 3 x 5, 7
	2	2152 939-34	72, 6 x 5, 5
2	2152 999-3	69, 2 x 5, 7	
2	2152 999-4	89, 1 x 5, 7	

SPARE PARTS FOR OPERATING MECHANISM BLG 1002

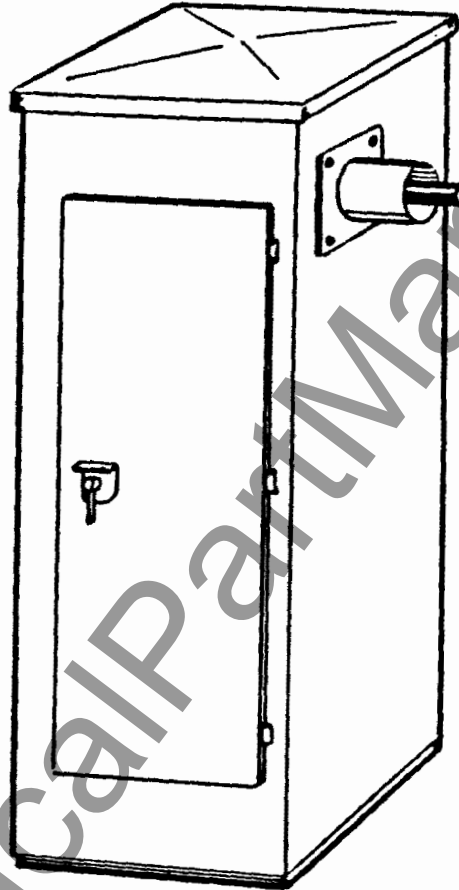

BLG 1002

Recommended spare parts are marked

R

For more than 10 operating mechanisms in
service we also recommend spare parts marked

RR

www.ElectricalPartManuals.com

OPERATING MECHANISM BLG 1002

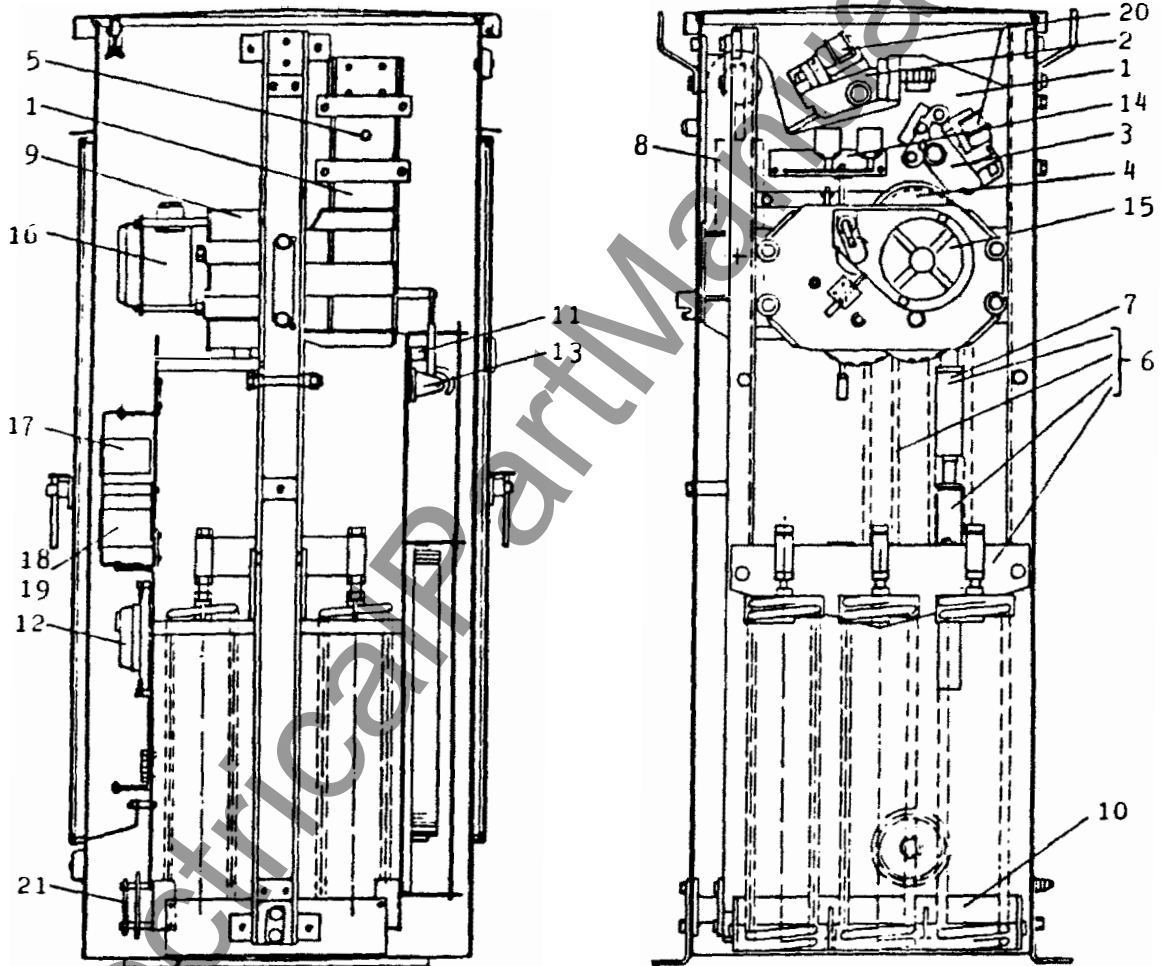

BLG 1002

Item No.	Qty	Name of item	Article No.	Sub List	Note
1	1	Operating mech	5438 078-BK	7	
2	1	Catch gear, off	5436 008-N	11	RR
3	1	Catch gear, on	5436 008-U	13	RR
4	1	Camshaft	5438 078-BL	15	
5	1	Operating lever	5251 710-P	9	
6	1	Spring chare dev.	5256 707-Y	21	
7	1	Dashpot, on	5256 707-	23	RR
8	1	Dashpot, off	5256 707-N	17	RR
9	1	Spurgear	2399 042-AB	19	
10	1	Spring bridge	5259 718-B		R
11	1	Counter	5691 851-4	29	
12	1	Thermostat	5438 064-F		
13	1	Aux. switch		29	
14	1	Limit switch	5438 086-AP	25-27	
15	1	Motor unit	5275 811-L	28	
16		Motor	\		RR
17		Motorstarter			R
18		Contacter	Elcomponents	30	RR
19		Relay			RR
20		Magnet coil			R
21		Heater	/		R
	1	Set of hardware	5439 138-A	31	R
	1	Set of gaskets	5429 038-K	23	R

Mechanism

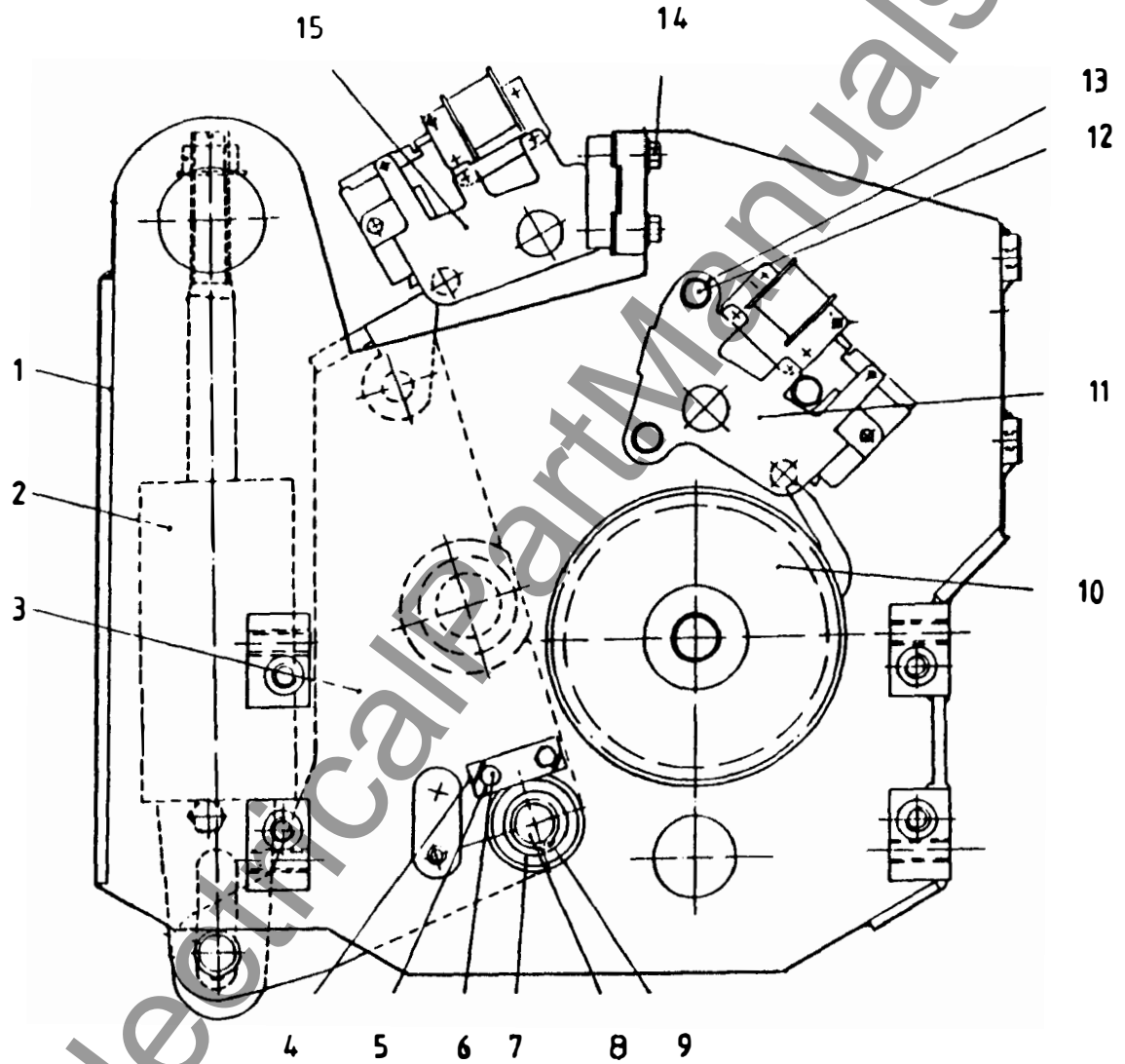

BLG 1002

Item No.	Qty	Name of item	Article No.	Sub List	Note
1	1	Frame	5284 863-19		
2	1	Dashpot off	5256 707-N	17	RR
3	1	Operating lever	5251 710-P	9	BLG1002
4	1	Washer	2154 748-10		
5	1	Lock washer	2154 2265-57		
6	2	Screw M8x16	2121 2016-408		
7	2	Ball bearing	2213 2002-206		
8	1	Shaft	2111 827-19		
9	1	Retaining ring	2154 2526-130		
10	1	Camshaft	5438 078-BL	15	RR
11	1	Catch gear on	5436 008-U	13	RR
12	3	Screw M10x100	2121 2017-505		
13	7	Spring washer	2154 2033-10		
14	4	Screw M10x40	2121 2017-495		
15	1	Catch gear off	5436 008-N	11	RR

Operating lever

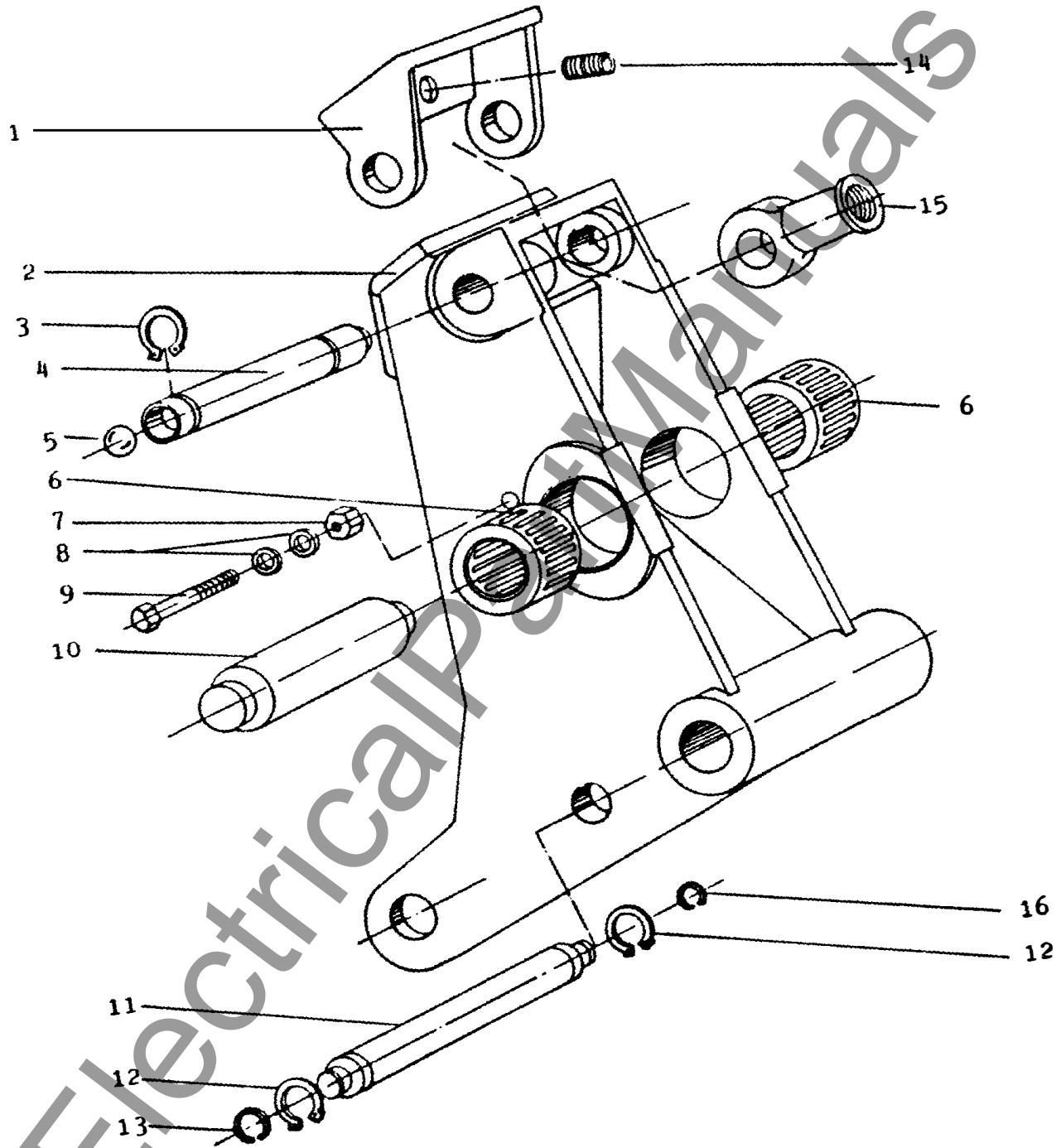

Operating lever 5251 710-P BLG 1002

Item No.	Qty	Name of item	Article No	Note
1	1	Catch	2167 809-2	RR
2	1	Operating lever	5251 705-5	BLG1002
3	2	REtaining ring	2154 2526-122	
4	1	Pin	2111 805-25	
5	2	Ball 1/2"	2213 0111-39	
6	2	Needle bearing	2213 4994-23	
7	4	Lock nut	2126 2801-115	
8	8	Washer	2151 837-26	
9	4	Screw M6x40	2121 2016-265	
10	1	Roller	2111 828-12	
11	1	Pin	2116 745-7	
12	2	Retaining ring	2154 2526-118	
13	1	Retaining ring	2154 2532-7	
14	2	Spring	2192 733-7	
15	1	Coupling	2184 889-X	
16	1	Retaining ring	2154 2532-4	

Catch gear, off

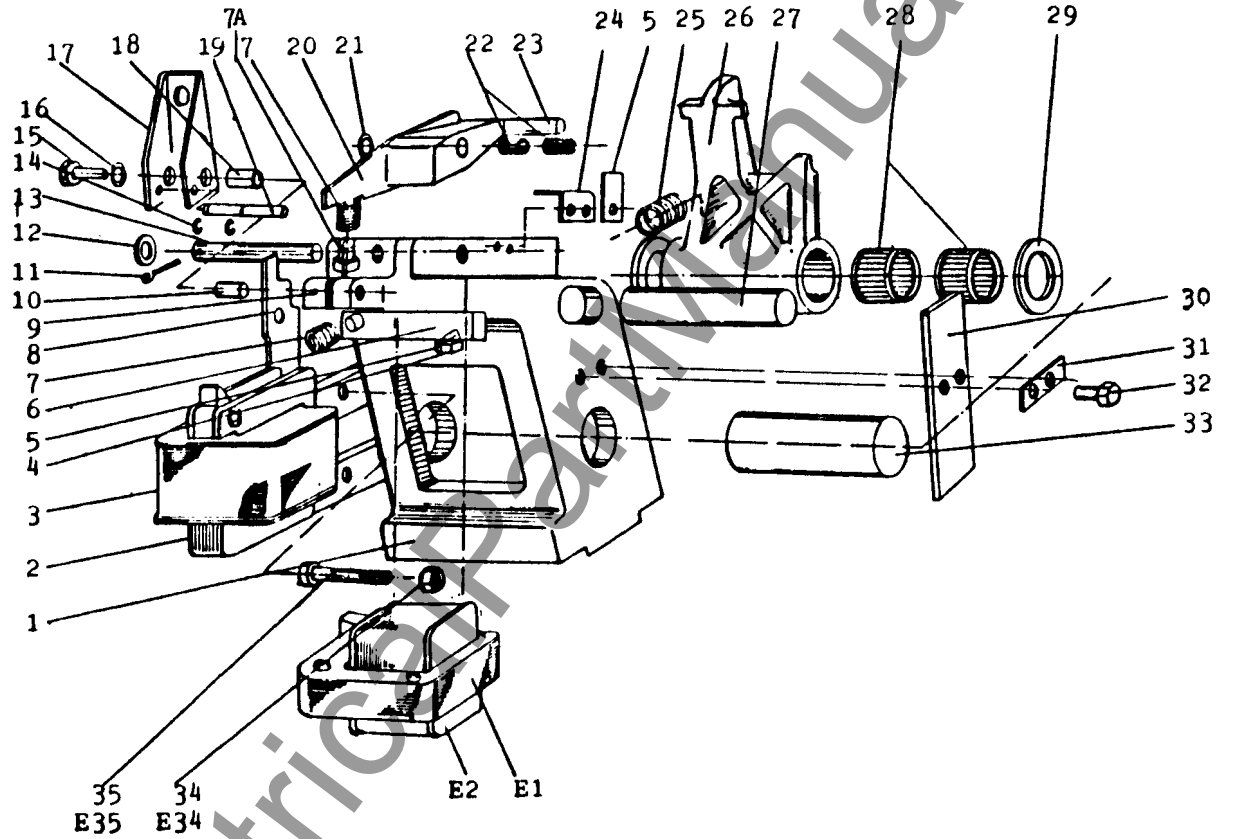

Catch gear, off 5436 008-N

Item No.	Qty	Name of item	Article No	Note
1	1	Catch holder	2162 752-5	
2	1	Magnet	5438 020-H	
3	1	Coil	1)	R
4	1	Screw M6x25	2121 2016-262	
5	3	Lock washer	2154 2233-153	
6	1	Holder	2116 745-5	
7	2	Spring	2192 007-22	
7A	1	Pin	2111 805-19	
8	1	Catch	2167 727-17	RR
9	1	Roll pin	2111 2835-168	
10	1	Pin	2111 2021-305	
11	2	Split pin	2114 2050-150	
12	2	Washer	2151 2064-165	
13	1	Pin	2111 827-14	
14	2	Retaining ring	2154 2532-4	
15	1	Screw M6x30	2121 2016-263	
16	2	Washer	2151 2064-153	
17	1	Stirrup	2175 774-35	
18	1	Spacer	2151 2082-435	
19	1	Pin	2111 828-11	
20	1	Catch	2167 727-11	RR
21	2	Washer	2151 2086-38	
22	2	Needle bushing	2213 1906-1	
23	1	Roller	2213 0121-136	RR
24	2	Holder	2155 729-8	
25	1	Spring	2192 2021-365	
26	1	Catch	2167 809-1	RR
27	1	Roller	2111 828-4	RR
28	2	Needle bushing	2213 1906-6	
29	2	Washer	2151 2096-30	
30	2	Cover plate	2172 805-71	
31	2	Lock washer	2154 2265-34	
32	6	Screw M6x8	2121 2016-254	
33	1	Shaft	2111 828-10	
34	2	Lock nut	2126 2801-115	
35	2	Screw M5x40	2121 2452-339	
Additional items for extra magnet				
E1	1	Extra magnet	5436 008-P	
E2	1	Coil	1)	R
E34	2	Lock nut	2126 2801-115	
E35	2	Screw M5x40	2121 2452-339	

1) Sub list 30

Catch gear, on

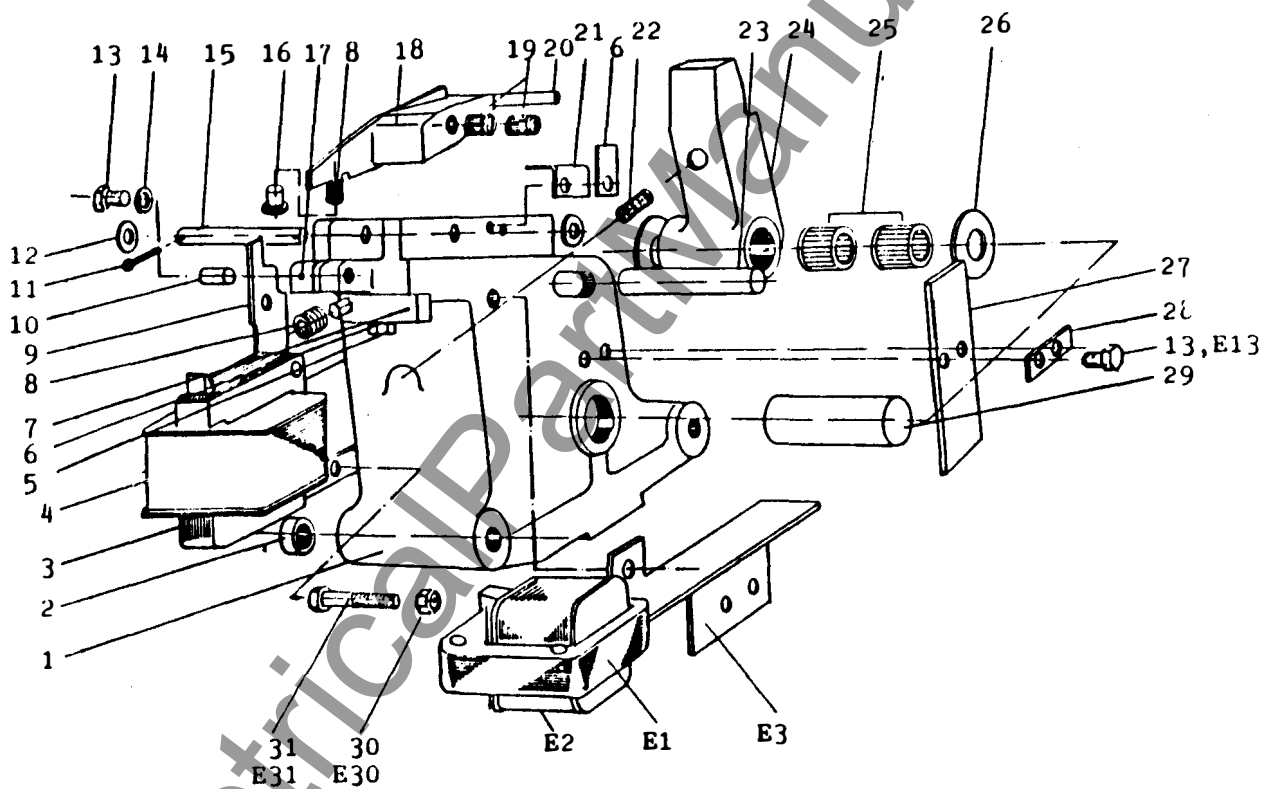

Catch gear, on 5436 008-U

Item No.	Qty	Name of item	Article No	Note
1	1	Catch holder	2162 752-7	
2	3	Spacer	2151 833-65	
3	1	Magnet,assy	5438 020-II	
4	1	Coil	1)	R
5	1	Screw M6x25	2121 2016-262	
6	3	Lock washer	2154 2233-153	
7	1	Holder	2116 745-5	
8	2	Spring	2192 007-22	
9	1	Catch	2167 727-17	RR
10	1	Pin	2111 2021-305	
11	2	Split pin	2114 2050-150	
12	2	Washer	2151 2064-165	
13	7	Screw M6x8	2121 2016-254	
14	1	Spring washer	2154 2032-7	
15	1	Pin	2111 827-14	
16	1	Pin	2111 805-19	
17	1	Roll pin	2111 2835-168	
18	1	Catch	2167 727-11	RR
19	2	Needle bushing	2213 1906-1	
20	1	Roller	2213 0121-136	RR
21	2	Holder	2155 729-8	
22	1	Spring	2192 2021-169	
23	1	Roller	2111 828-17	RR
24	1	Catch	2167 809-5	
25	2	Needle bushing	2213 1906-5	
26	2	Washer	2151 2096-72	
27	2	Cover plate	2172 805-71	
28	2	Lock washer	2154 2265-34	
29	1	Shaft	2111 828-16	
30	2	Lock nut M5	2126 2801-115	
31	2	Screw M5x40	2121 2452-339	
Additional items for extra magnets				
E1	1	Extra magnet	5436 008-V	
E2	1	Coil	1)	R
E13	2	Screw M6x16	2121 2016-258	
E30	2	Lock nut M5	2126 2801-115	
E31	1	Screw M5x40	2121 2452-339	
E31	1	Screw M5x30	2121 2452-335	

1) Sub list 30

Camshaft

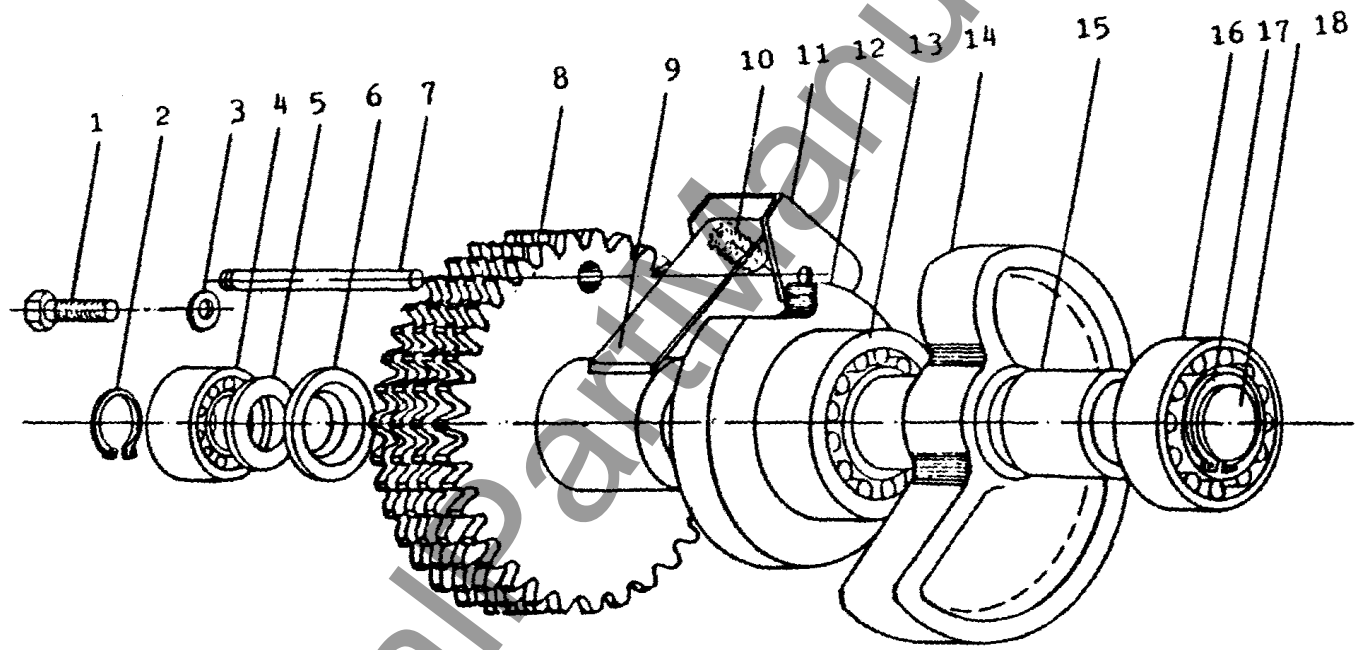

www.ElectricalManuals.com

Camshaft 5438 078-BL

Item No.	Qty	Name of item	Article No	Note
1	1	Screw M6x8	2121 2016-254	
2	1	Retaining ring	2154 2526-130	
3	1	Spring washer	2154 2033-7	
4	1	Roller bearing	2213 2002-206	
5	1	Washer	2151 2096-72	
6	1	Spacer	2151 830-5	
7	1	Pin	2111 827-30	
8	1	Sprocket	2257 954-21	
9	1	Arm	2184 4323-B	
10	1	Spring	2192 007-430	
11	1	Catch	2167 809-6	RR
12	1	Interlocking disc	2185 971-5	
13	1	Roller bearing	2213 2002-210	
14	1	Cam disc	2185 950-6	
15	1	Spacer	2151 833-47	
16	1	Roller bearing	2213 2002-209	
17	1	Retaining ring	2154 2526-139	
18	1	Shaft	2235 023-16	

Dashpot, off

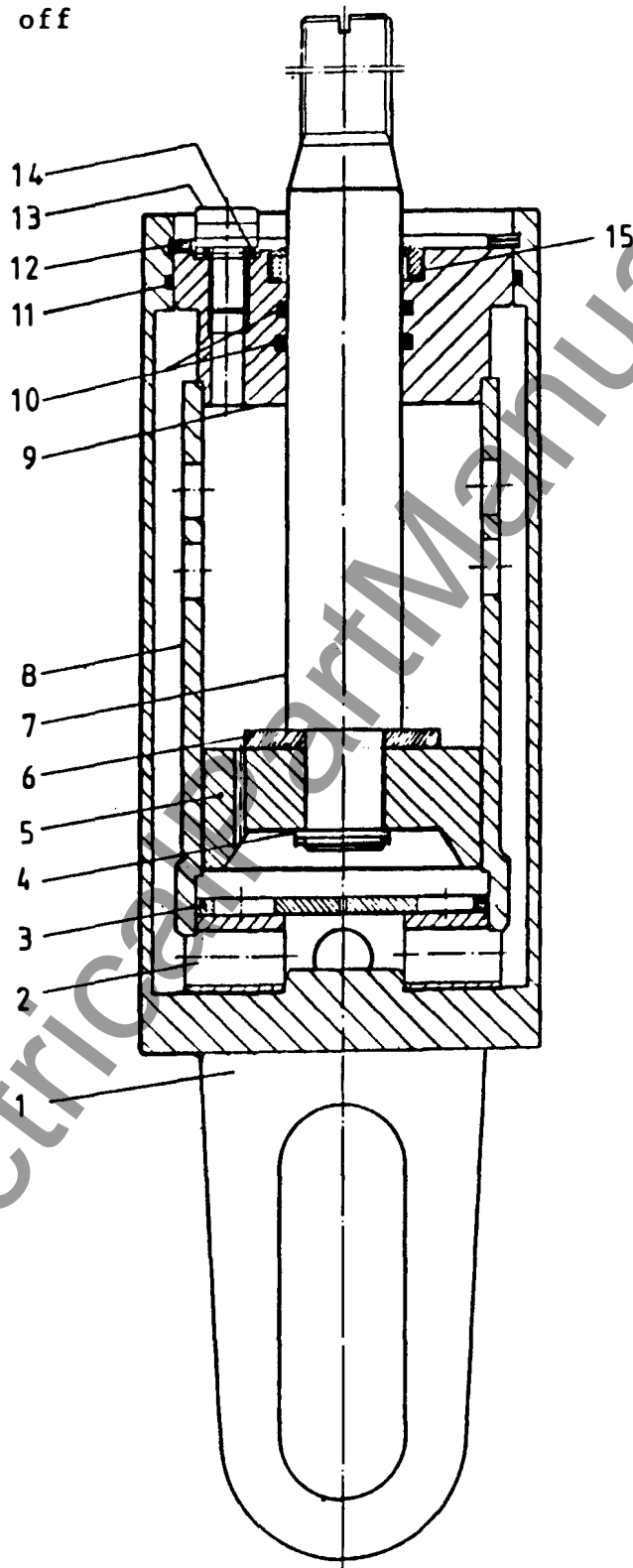

Dashpot, off 5256 707-N 1)

Item No.	Qty	Name of item	Article No	Note
1	1	Oil buffer	2196 739-A	RR
2	1	Washer	2196 725-15	
3	1	Valve disc	2171 738-8	
4	2	Retaining ring	2154 2526-122	
5	1	Piston	2196 725-10	
6	1	Washer	2151 837-25	
7	1	Piston rod	2196 725-9	
8	1	Cylinder	1)	
9	1	Cover	2196 725-12	
10	1	O-ring	2152 929-35	R
11	1	O-ring	2152 930-90	R
12	1	Retaining ring	2154 2527-158	
13	1	Screw M10x16	2121 2519-489	
14	1	Sealing washer	2152 2031-5	R
15	1	Wiper	2216 2041-12	
		Oil 650 cm3	1171 3011-102	R

- 1.) When ordering complete dashpot or cylinder item 8 give also serial number for the operating mechanism.

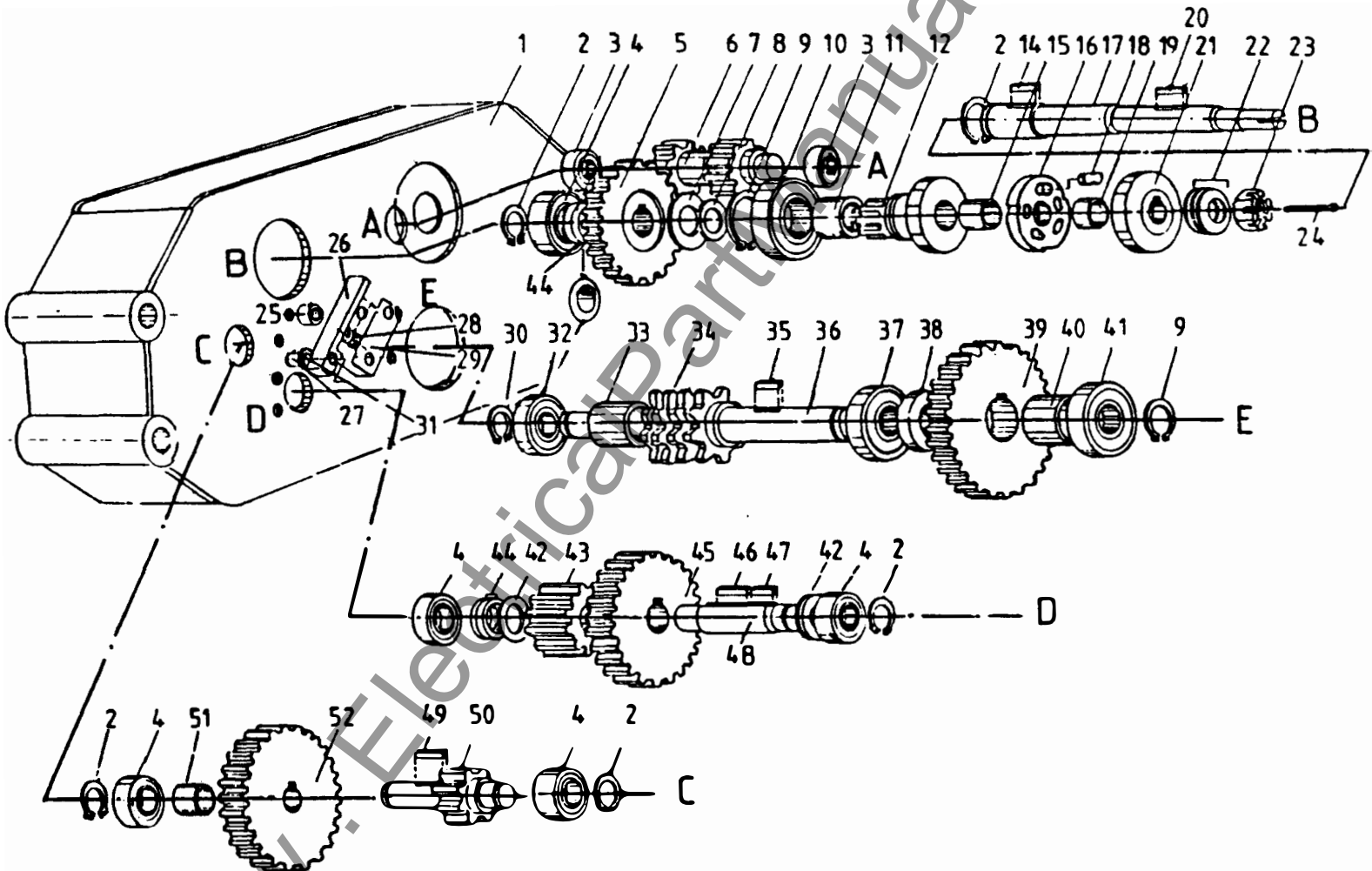

Spur gear

Spur gear 2399 042-AB

Item No.	Qty	Name of item	Article No	Note
1	1	Frame	5284 863-14	
2	4	Retaining ring	2154 2526-122	
3	2	Ball bearing	2213 6001-101	
4	5	Ball bearing	2213 6651-104	
5	1	Gear wheel	2321 712-12	
6	1	Gear wheel	2321 742-2	
7	1	Washer	2151 2076-4	
8	1	Washer	2151 907-9	
9	2	Retaining ring	2154 2526-130	
10	1	Ball bearing	2213 6650-206	
11	1	Bushing	2211 2041-15	
12	1	Gear wheel	2321 713-5	
14	1	Key	2157 2011-228	
15	1	Bushing	2211 2041-8	
16	1	Interlocking disc	2185 971-8	
17	1	Shaft	2235 023-14	
18	5	Friction insert	2281 072-1	
19	1	Bushing	2211 814-12	
20	1	Key	2157 2011-139	
21	1	Friction disc	2281 969-6	
22	19	Cup spring	2195 2011-49	
23	1	Slotted nut	2126 2711-122	
24	1	Split pin	2114 2050-183	
25	2	Spacer	2151 2082-311	
26	1	Catch	2167 727-19	
27	1	Pin	2111 789-355	
27A	2	Washer	2151 2064-153	
28	1	Spring	2192 007-382	
29	1	Yoke	2175 774-33	
30	1	Retaining ring	2154 2526-126	
31	2	Retaining ring	2154 2532-4	
32	1	Ball bearing	2213 6000-205	
33	1	Spacer	2151 833-69	
34	1	Sprocket	2257 954-18	
35	1	Key	2157 2011-365	
36	1	Shaft	2235 023-17	
37	1	Ball bearing	2213 2002-206	
38	1	Spacer	2151 833-52	
39	1	Gear wheel	2321 711-6	
40	1	Spacer	2151 833-29	
41	1	Ball bearing	2213 6650-206	
42	3	Washer	2151 2092-102	
43	1	Gear wheel	2321 711-8	
44	3	Spacer	2151 833-32	
45	1	Gear wheel	2321 711-9	
46	1	Key	2157 2011-811	
47	1	Key	2157 2011-295	
48	1	Shaft	2235 023-15	
49	1	Key	2157 2011-226	
50	1	Gear wheel	2321 715-3	
51	1	Spacer	2151 833-30	
52	1	Gear wheel	2321 711-7	

Spring charge device

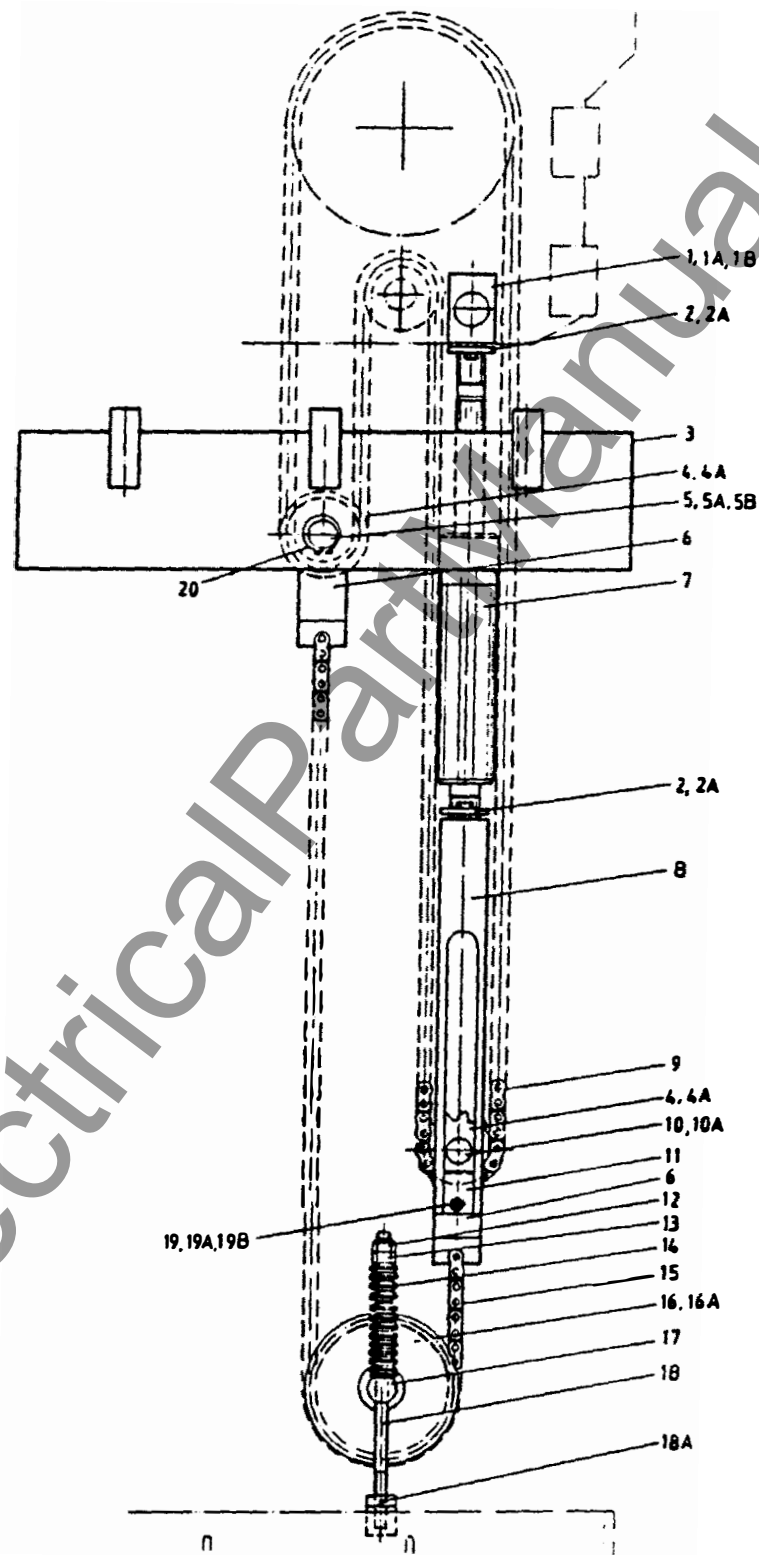

Spring charge device 5256 707-Y BLG 1002

Item No.	Qty	Name of item	Article No	Sub List	Note
1	1	Holder	2172 805-133		
1A	2	Screw M16x25	2121 2017-592		
1B	1	Lock washer	2154 773-2		
2	2	Locking bar	2172 832-23		
2A	2	Screw M12x25	2121 2017-525		
3	1	Yoke	5259 724-2		
4	2	Sprocket	2257 954-19		
4A	4	Bushing	2211 2042-27		
5	1	Shaft	2111 827-28		
5A	1	Spacer	2151 2092-210		
5B	2	Washer	2151 2096-67		
6	2	Holder	2175 890-28		
7	1	Dashpot	5256 707-G	23	RR
8	1	Link	2184 938-AK		
9	1	Chain	2182 704-12		
10	1	Pin	2111 827-29		
10A	1	Roll pin	2111 2835-383		
11	2	Holder	2174 736-57		
12	2	Lock nut M12	2126 2801-122		
13	2	Nut M12	2126 2011-122		
14	168	Cup spring	2195 2011-44		
15	1	Chain	2182 704-4		
16	1	Wheel	2257 954-6		
16A	1	Bushing	2211 2042-28		
17	1	Shaft	2111 805-13		
18	2	Stud	2122 768-101		
18A	2	Roll pin	2111 2835-166		
19	2	Stud	2122 2012-370		
19A	2	Lock nut M6	2126 2801-116		
19B	2	Roll pin	2111 2835-210		
20	2	Retaining ring	2154 2526-126		

Dashpot, on

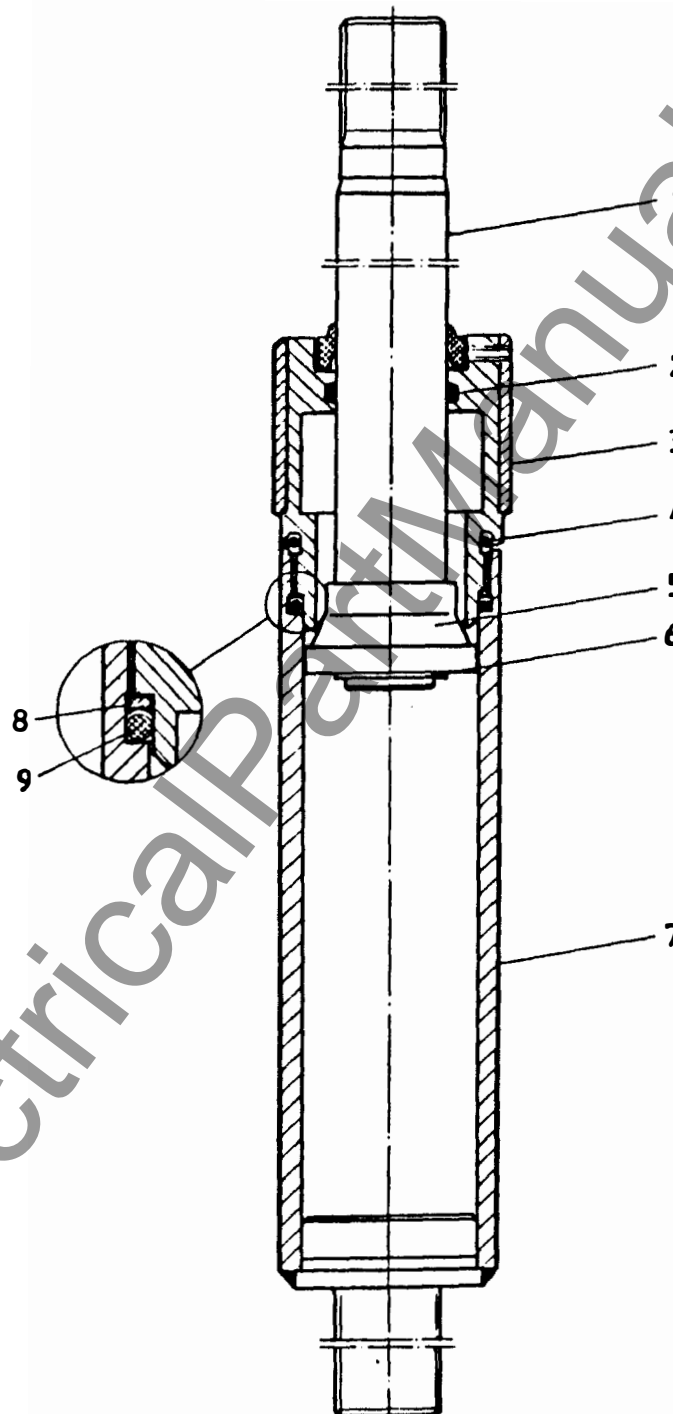

Dashpot, on 5256 707-AP

Item No.	Qty	Name of item	Article No	Note
1	1	Piston rod	2196 725-4	
2	1	O-ring 24,2x3	2152 929-30	R
3	1	Cover	2196 731-C	
4	1	O-ring 42,2x3	2152 929-48	R
5	1	Piston	2196 725-24	
			2196 725-28	1)
6	1	Retaining ring	2154 2526-122	
7	1	Cylinder	2196 715-A	
8	1	Support ring	2152 4028-1	R
9	1	O-ring 39, 2x3	2152 929-45	R
		Silicon oil 120 cm ³	1173 7011-106	RR

Complete set of gaskets for 1 dashpot OFF and 1 dashpot ON article no. 5429 038-K (R) containing:

Qty	Name of item	Dimension	Article No.
1	O-ring	24,2x3	2152 929-30
2	O-ring	29,2x3	2152 229-35
1	O-ring	39,2x3	2152 929-45
1	O-ring	42,2x3	2152 929-48
1	O-ring	84,5x3	2152 930-90
1	Support ring		2152 4028-1

Limit switch

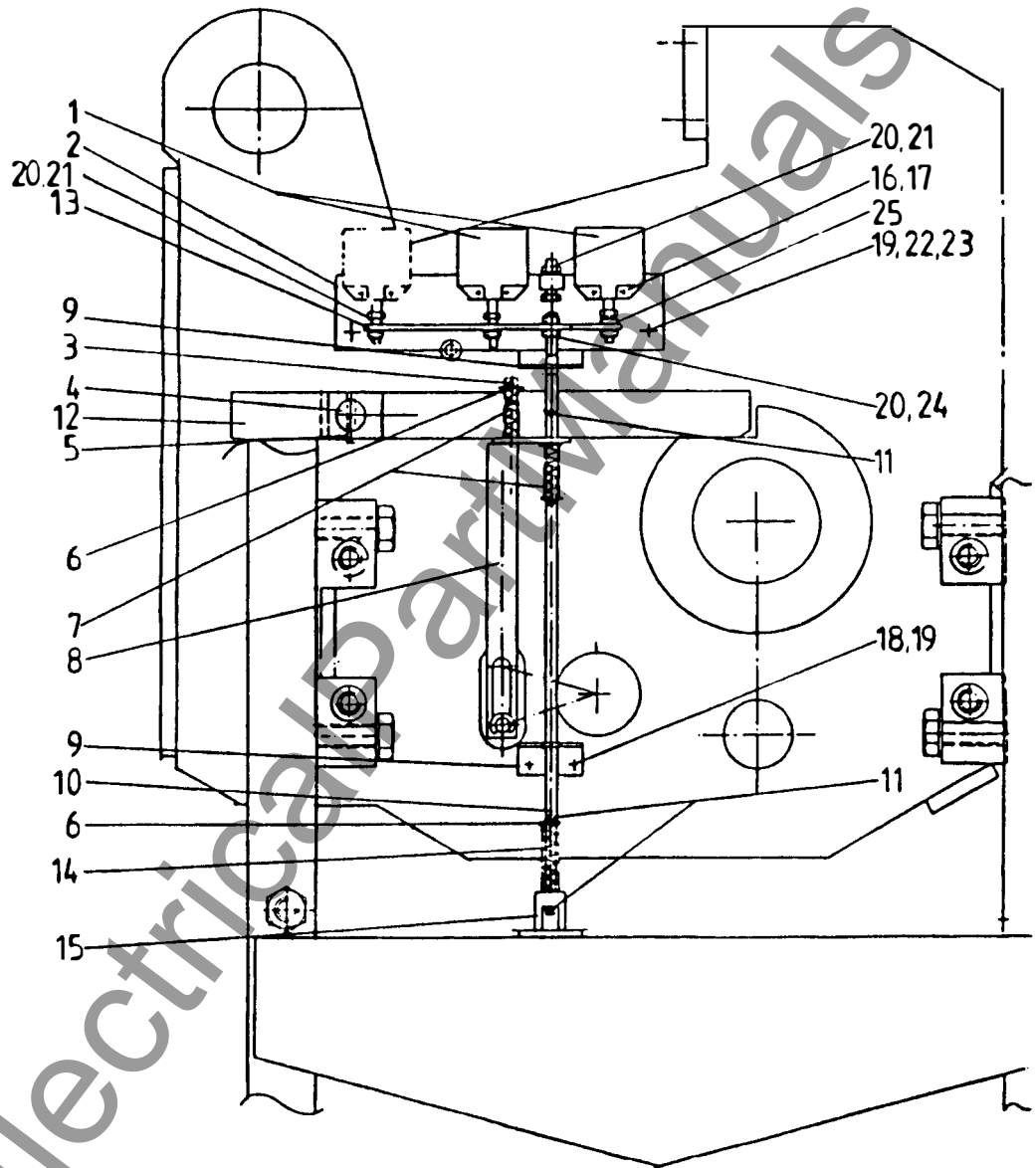

LIMIT SWITCH 5438 086-AX

Item No.	Qty	Name of item	Article No	Note
1	2	Contact device	SK 652 0005	RR
2	1	Holder	2184 4067-H	
3	1	Roll pin	2111 2835-306	
4	1	Pin	2111 805-29	
5	1	Roll pin	2111 2835-313	
6	4	Washer	2151 2064-165	
7	2	Spring	2192 2021-259	
8	1	Guide bar	2172 805-113	
9	2	Holder	2174 736-63	
10	1	Pull rod	2111 805-31	
11	4	Roll pin	2111 2835-208	
12	1	Locking arm	2184 4067-G	
13	1	Arm	2172 805-165	
14	1	Spring	2192 2021-272	
15	1	Slipper	2172 805-167	
16	4	Recessed screw	2121 2459-297	
17	4	Lock nut	2125 2801-112	
18	4	Hexagon head bolt	2121 2016-260	
19	6	Lock nut	2126 2801-116	
20	5	Lock nut	2126 2801-115	
21	4	Hexagon head bolt	2121 2033-414	
22	2	Spacer	2151 2082-335	
23	2	Hexagon head bolt	2121 2016-263	
24	1	Hexagon nut	2126 2028-117	
25	1	Spacer	2151 2082-260	

Motor unit 5275 811-L

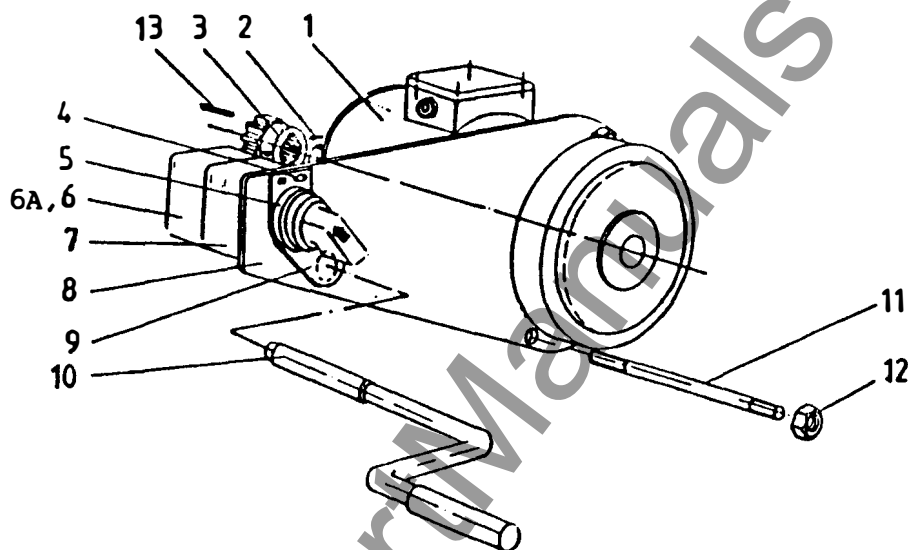

Item No.	Qty	Name of item	Article No	Sub List	Note
1	1	Motor		28	RR
2	1	Roll pin	2111 2835-210		
3	1	Gear wheel	2321 713-4		
4	1	Marking plate	2949 0421-1		
5	1	Spacer	2151 830-3		
6	1	Contact device	SK 615 010-C		
6A	1	Contact device	SK 615 001-F		
7	1	Switch	SK 615 203 FF		
8	1	Motorbracket	2173 731-39		
9	1	Cover plate	2174 929-E		
10	1	Crank	2188 754-A		
11	2	Stud M8x180	2122 2273-482		
12	2	Lock Nut M8	2126 2801-117		
13	1	Wedge	2157 2011-141		

Auxiliary switch and counter 5438 086-AP

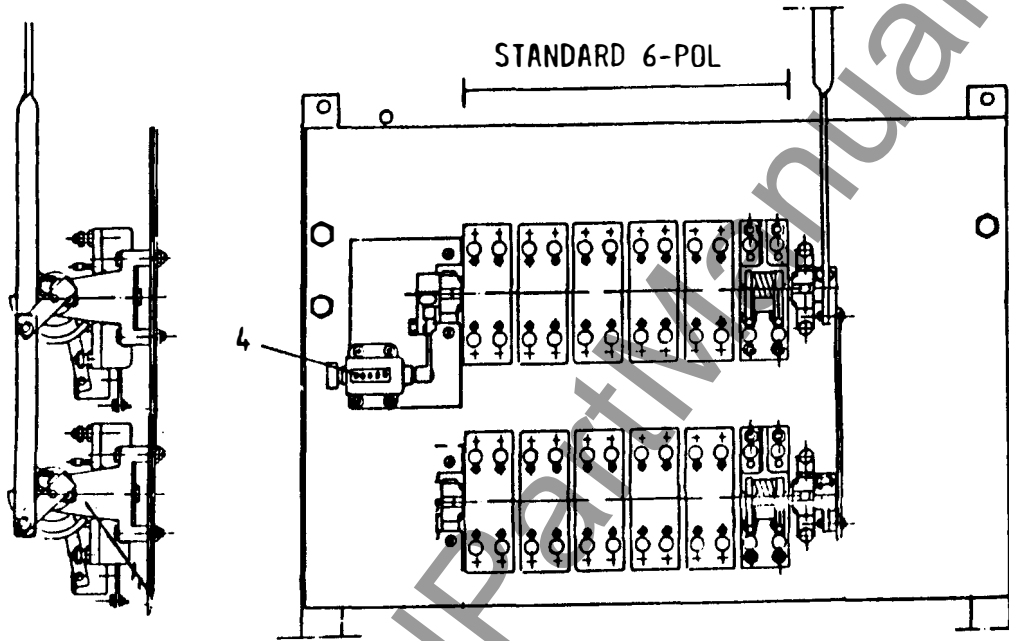

Item No.	Qty	Name of item	Article No	Note
3	1	Aux. switch 6-pole	1604 670-G	BLG 1002
4	1	Counter	5691 851-4	

Set of hardware, art.no. 5439 138-A
The set consists of 5 pieces of following items

1. Hex. head bolt

2121	2016-226	SKR6	M5X8
	-254		M6X8
	-256		M6X12
	-258		M6X16
	-260		M6X20
	-262		M6X25

2. Recessed screw

2121	2459-226	SKRC	M3X12
	-230		M3X20
	-297		M4X25
	-323		M5X8
	-327		M5X12
	-329		M5X16
	-331		M5X20

3. Locknut

2126	2801-110	MUTL	M3
	-112		M4
	-115		M5
	-116		M6
	-117		M8
	-120		M10
	-122		M12

4. Washer

2151	2064-136	BRIR	4.3X8X0.5
	-146		5.3X10X1
	-153		6.4X12X1.5
	-165		8.4X16X1.5
2151	2086-38		8.1X16X0.5

5. Lock washer

2154	2233-153	BRIV	6.4
	-173		10.5
2154	2265-34		7X20
	-57		9.5X30

6. Spring washer

2154	2032-6	BRIF	5,3
2154	2033-7		6,4
	-9		8,4
	-10		10.5
	-12		13

7. Roll pin

2111	2835-166	PINF	2X12
	-168		2X16
	-208		3X16
	-210		3X20
	-261		4X30
	-306		5X16
	-308		5X20
	-313		5X30

8. Split pin

2114	2050-152	PINS	2X16
	-183		3.2X25
	-197		4X25
	-215		5X36

9. Retaining ring

2154	2526-114	LASR	11
	-118		14.7
	-122		18.5
	-126		23.2
	-130		27.9
	-137		36.5
2154	2532-4		4.0
	-5		5.1
	-6		6.2
	-8		8.6



www.ElectricalPartManuals.com

ASEA BROWN BOVERI

ABB POWER TRANSMISSION INC.

Gas filling with SF6 + N2 NOTE: For ambient temperatures below -40° F only

In cases where the circuit breaker is to be filled with "mixed gas" (SF6 + N2) an extra reducing valve article number 429A064-02 is required, with screw threads adapted to a nitrogen gas tube.

In order for the SF6 gas not to condensate at temperatures below -40° F the pressure must be reduced.

Depending on the insulation requirement, in certain cases it is necessary to increase the pressure by means of refilling with nitrogen gas - N2 - which shall be mixed with SF6 gas in the circuit breaker.

The filling pressure for the SF6 gas and, in applicable cases, the refilling pressure for nitrogen gas, are always given on the data plate of the circuit breaker.

Trial operation of the circuit breaker shall only be carried out after the nitrogen gas has also been filled in, so that full pressure has been obtained.

At "mixed gas filling", SF6 gas shall first be filled in to 44.4 PSI abs ($+68^{\circ}$ F) and the N2 to 74 PSI abs ($+68^{\circ}$ F).

At refilling of gas due to, for instance, leakage, the pressure proportions shall be

60% SF6 + 40% N2

Ex: Normal density value 74 PSI abs.

Leakage has occurred down to 62.4 PSI abs.
(A signal has been obtained at 65.3 PSI abs)
 $74 - 62.4 = 11.6$

$60\% \times 11.6 = 7.0$

Fill up with SF6 gas to $63.4 + 7.0 = 70.4$ PSI abs. and then with N2 gas to 74 PSI abs.

www.ElectricalPartManuals.com

**INSTRUCTION MANUAL
FOR
SERIES A1000
ANNUNCIATORS**

SEEKIRK

Seekirk, Inc.
2295 Scioto Harper Road
Columbus, Ohio 43204

Tele: (614) 278-9200

MARCH 6, 1987

www.ElectricalPartManuals.com

INSTRUCTION MANUAL FOR
SERIES A1000 ANNUNCIATORS

TABLE OF CONTENTS

	Page
1.0 UNPACKING AND HANDLING	1
2.0 INSTALLATION AND START UP PROCEDURE	1
3.0 SPARE PARTS	4
4.0 WARRANTY	4
5.0 DRAWINGS	4

PROPRIETARY NOTICE

The information contained in this manual is property of Seekirk Incorporated. It's use is conditioned upon the User's agreement not to copy or reproduce the information or drawings contained in whole or in part, or to use the information or drawings to reproduce the material described therein, or for any other purpose, without written permission from Seekirk, Incorporated.

SEEKIRK

2295 Scioto-Harper Road
Columbus, Ohio 43204
(614) 278-9200

Manufacturers of Quality Annunciating Systems

INSTRUCTION MANUAL FOR

SERIES A1000 ANNUNCIATORS

1.0 UNPACKING AND HANDLING

1.1 Immediately upon receipt the packing list should be examined to assure that there is no shortage. The packing list is always an integral part of every shipment and for shipments involving several containers; the one marked "Packing List Enclosed" should be opened first.

1.2 Immediately after unpacking, a visual check should be made with particular attention to the following areas:

1.2.1 Any concealed damage to the enclosure, especially to assure that painted surfaces are free from marks or scratches.

1.2.2 All lens caps and engraved legend plates to assure that they are securely in place.

1.2.3 Wiring in general with particular attention to solder connections to assure that there are not loose wires.

1.2.4 All mounting and terminal barrier screws to assure that they are properly tightened.

1.3 If there is physical damage due to improper handling by the carrier, preserve packing container and call the carrier immediately. He will instruct you on how to file a claim. After notifying the carrier, Seekirk, Incorporated should be informed as to the specific equipment and extent of damage. This will insure proper repair or scheduling of replacement equipment prior to settling the claim with the carrier. Always include as much information as possible to avoid undue delays and identifying with your purchase order number, Seekirk's internal S.O.R. number, and Serial Number (see packing list). Any claim for shortage, defects, or errors in shipment must be made in writing and within 10 days after receipt of goods.

2.0 INSTALLATION AND START UP PROCEDURE

CAUTION: The following tests are functional. If voltage breakdown tests or insulation resistance tests with other than low voltage ohmmeter are to be performed, all TEST-RESET/OFF-ON switches must be placed in the RESET/OFF or center position, in order to prevent damage to the solid state components and relay contacts.

WARNING

VOLTAGES DANGEROUS TO LIFE ARE PRESENT
WHEN POWER IS APPLIED TO THIS UNIT

2.1 All A1000 Series annunciators come completely pre-wired with twelve point modules fastened securely to the back side of the front cover. Check to assure that there are (12) modules present and that they are appropriately labeled and dated. The point module numbering system for all A1000 Series annunciators always consists of a four digit number with either a two or three letter suffix. In all cases the first three digits will be a 911 with the fourth digit being either a 2, 3, or 4 depending on whether it is a 24, 48, or 125 VDC module, respectively. The suffix letters will vary depending upon the Series Model Number. To derive this information, locate the pertinent drawing at the rear of this text. A table on the drawing will provide the appropriate point module numbers.

2.2 Wall mounted units are installed by mounting the annunciator enclosure securely to the wall with two #12 screws. Hole knockouts are provided on rear of enclosure for this purpose. No further mechanical adjustments are required.

2.3 Units to be flush or panel mounted are installed by mounting annunciator through a 5-1/2" x 17-1/2" panel cutout, and then securing the four supplied "J" Bolts through the hole knockouts located on unit sides.

2.4 Conduit knockouts are provided at top and bottom of unit to facilitate wire installation.

2.5 All Series A1000 annunciators are provided with a sixteen-point input terminal block, TB-1. Terminals 1-12 are to be wired to the customer contacts of which the opposite sides should be connected to the common battery positive (+) potential. Terminals 13 and 14 are tied together and should be connected to the battery positive (+). Terminal 15 should be connected to the battery negative (-).

2.6 All Series A1000 annunciators are provided with at least two 12-point output terminal blocks, TB-2 and TB-3. The A1000A or A1000B Series units are provided with two additional terminal blocks TB-4 and TB-5. TB-2 and TB-4 (if provided) are numbered 1-12; TB-3 and TB-5 (if provided) are numbered 13-24. In all cases there are two terminals provided for each pair of point module contacts. In other words, terminals 1 and 2 of TB-2 and TB-5 correspond to the contacts of point #1; terminals 3 and 4 to the contacts of point #2; and so on. For detailed wiring information for the model you have, always refer to the appropriate installation and wiring diagram at the rear of the manual.

2.7 To insure proper operation of the unit it is good practice to first connect the power before wiring in the field inputs. This allows operation of the test switch to check the auxiliary contacts and lamps. If the unit is to be interconnected to a supervisory set or other alarm device, this wiring should be accomplished next and again the test switch used to check operation. Refer to the sequence table on the schematic drawing for proper operation. The next and final step is to wire each individual point to field contacts as required (see par. 2.7.1).

2.7.1 Field precautions when utilizing point module auxiliary contacts (Form a dry reed contact):

2.7.2 Contact Rating (Res. Load)

MAX. WATTS DC	MAX. V.A. AC	MAX. AMP.	MAX. VOLTS
15	15	1.5	250

For 50V DC Load, Max. I = 300mA

130V DC Load, Max. I = 115mA

2.7.3 Contact Protection

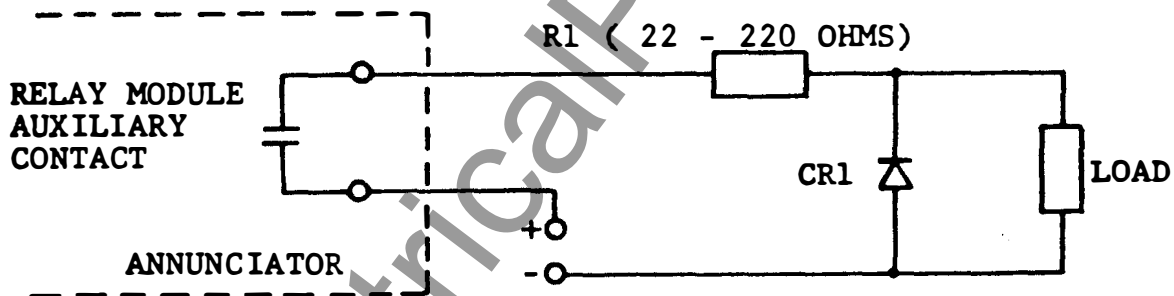

2.7.4 R1 should be connected in series with the contact to reduce the current surge for lamp or capacitive loads. For inductive load, such as Relay or Bell, CR1 should be connected in parallel with the load for inductive transient voltage suppression.

2.7.5 CR1 must have a reverse breakdown rating in excess of maximum battery voltage transient voltage. The forward current rating of CR1 should be in excess of the normal load current of the device(s) being suppressed.

2.8 When wiring is completed, a thorough point-by-point test should be performed to insure proper operation and the absence of wiring errors. In some cases, lamps are subjected to severe shock in shipment and may arrive damaged. If the individual point indicator does not light under test, pop off the lens cap and pull lamp straight out and replace it. Lamps are slide-base units and may be replaced at any time without removing power from the equipment.

3.0 SPARE PARTS

3.1 The design of Seekirk equipment minimizes the number of spare parts required. When ordering spare parts it is a primary importance to specify units by part number. Always make reference to Seekirk's internal S.O.R. number and Serial Number to insure exact interchangeability and proper operation. Spare parts orders received after shipment will be billed at existing prices at that time.

3.2 Recommended spare parts consist of the following items:

- (1) Box lamps (10 per box)
- (2) Point Modules

NOTE: Minimum Billing is \$30.00

4.0 WARRANTY

4.1 Seekirk, Incorporated, warrants that the apparatus delivered will be of a kind and quality described in the order or contract. In connection with the apparatus sold, Seekirk agrees to correct any defect(s) in workmanship or material, which may develop under proper or normal use during the period of one year from the date of shipment, by repair or replacements, freight paid by customer both ways, of the defective part(s), and such correction shall constitute a fulfillment of all Seekirk liabilities in respect to said apparatus. In no event shall Seekirk be liable for consequential damage.

5.0 DRAWINGS

5.1 An "Outline Dimensions and Installation" drawing, and a schematic for each standard model in the A1000 Series, are included in the following pages. The standard models covered are:

A1001	A1002A
A1001A	A1002B
A1001B	A1002R/O
A1002	A1003

5.2 If the model you have is different than above, a blueprint of the appropriate schematic will be included, separate from this manual.

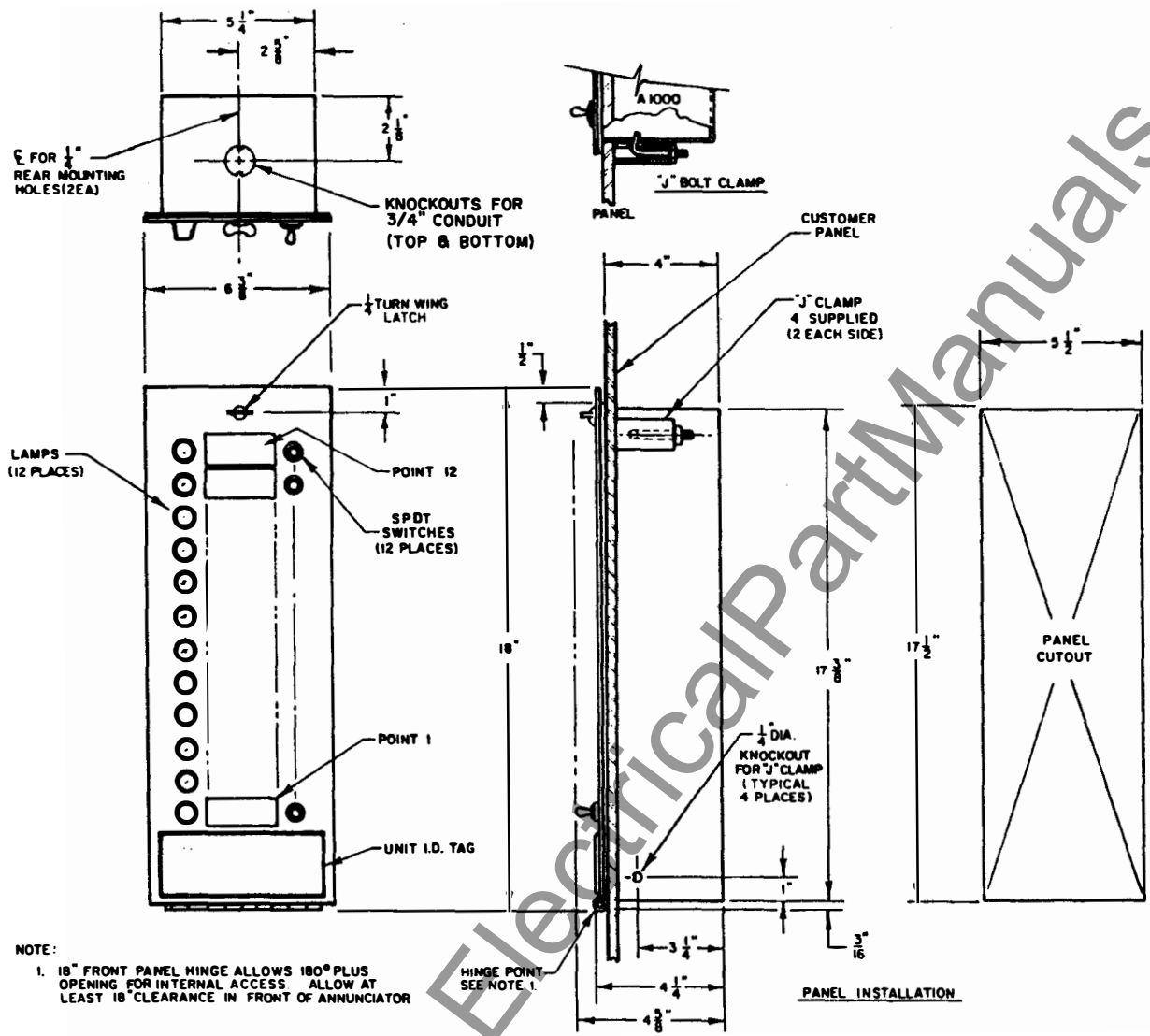

NOTE:
 1. 18" FRONT PANEL HINGE ALLOWS 180° PLUS OPENING FOR INTERNAL ACCESS. ALLOW AT LEAST 18" CLEARANCE IN FRONT OF ANNUNCIATOR

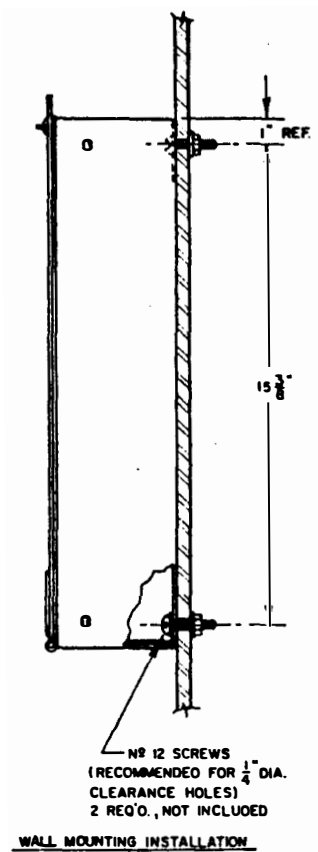

MODEL A1000 - OUTLINE & INSTALLATION DIMENSIONS

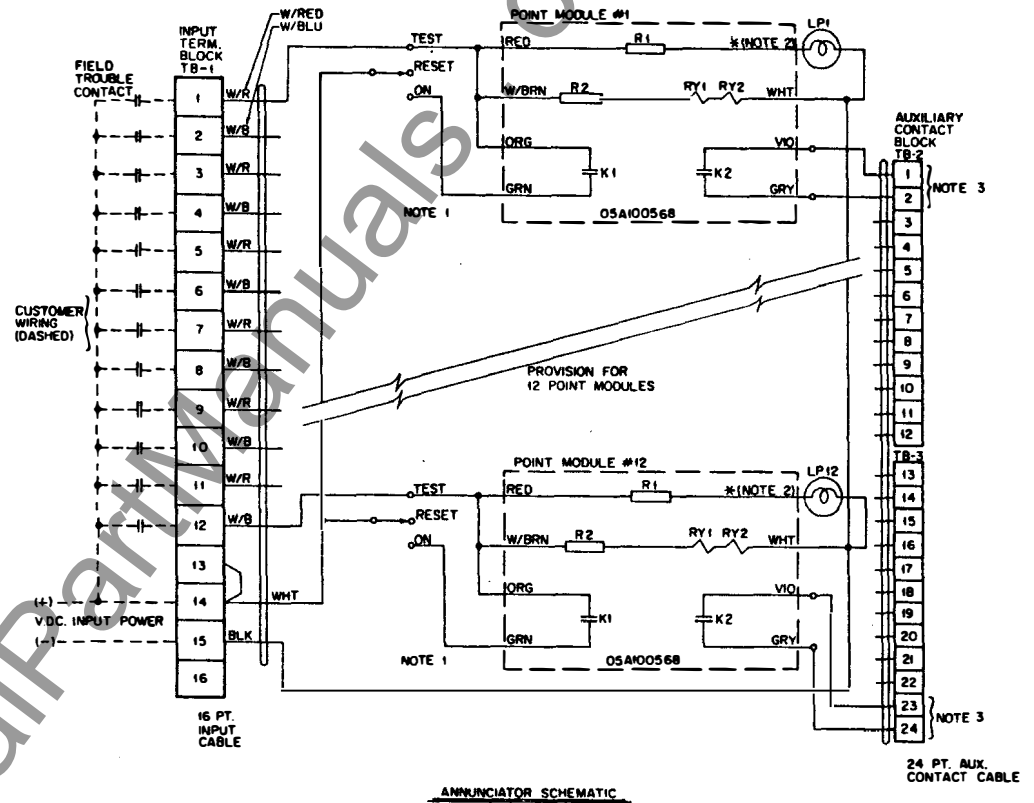
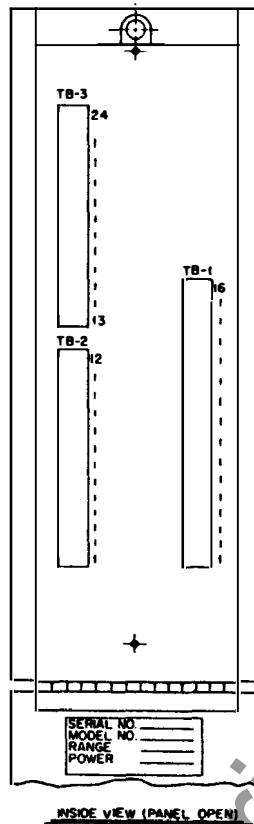
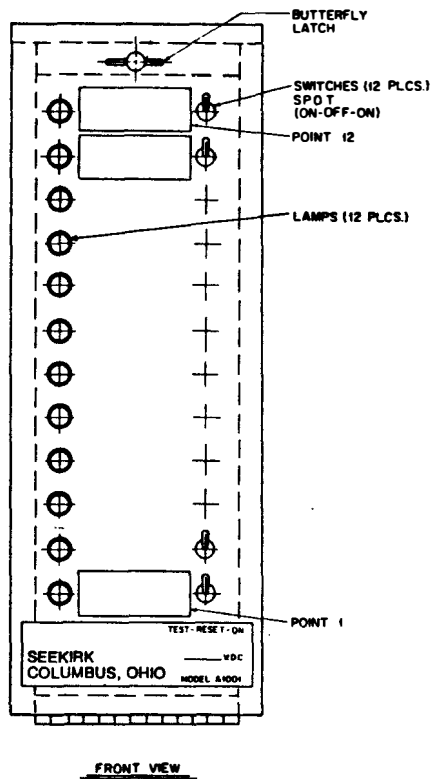

NOTES:

(1) FOR SEQUENCE SELECTION

- A) REMOVE GRN WIRE FOR SEQUENCE "A".
- B) RETAIN GRN WIRE FOR SEQUENCE "B".

	'A' SEQ. (FOLLOW THE CONTACT)		'B' SEQ. (LOCK-ON)	
	LAMP	AUX CONTACT	LAMP	AUX CONTACT
NORMAL	OFF	OPEN	OFF	OPEN
ALARM	ON	CLOSED	ON	CLOSED
RETURN TO NORMAL	OFF	OPEN	ON	CLOSED
RESET BEFORE RETURN TO NORMAL	ON	CLOSED	ON	CLOSED
RESET AFTER RETURN TO NORMAL	—	—	OFF	OPEN

(2) MODULES PROVIDED AS FOLLOWS:

VOLT	MODULE TYPE	COLOR CODE	PANEL LAMPS
125 V.D.C.	9114 PA	BLU	120 PSB
48 V.D.C.	9113 PA	YEL	48 PSB
24 V.D.C.	9112 PA	GRN	24 PSB

(3) CONTACT RATING (RESISTIVE LOAD)

VOLTS - 500 V.D.C. (MIN. BREAKDOWN)
 WATTS - 15 W MAX.
 VOLTS - 250 V.D.C. (MAX. SWITCHING)
 AMPS - 2.0 AMPS MAX. (GATING & CARRY)
 FOR 50 V.D.C. LOAD, MAX. I = 0.3 AMPS
 FOR 130 V.D.C. LOAD, MAX. I = 115 MA

A RESISTOR SHOULD BE CONNECTED IN SERIES W/ THE CONTACT TO REDUCE THE SURGE FOR LAMPS OR CAPACITIVE LOADS. FOR INDUCTIVE LOAD, SUCH AS A RELAY OR BELL, AN APPROPRIATE DIODE SHOULD BE CONNECTED IN PARALLEL W/ THE LOAD INDUCTIVE TRANSIENT VOLTAGE SUPPRESSION.

(4)

VOLT	POINT MODULE	R1	R2
125 V.D.C.	9114 PA	1.5K-1W	10K-3W
48 V.D.C.	9113 PA	220-1W	3.3K-1W
24 V.D.C.	9112 PA	47-1W	15K-1/2W

REFERENCE - DRAWING 02D100516

MODEL A1001 - INSTALLATION & WIRING

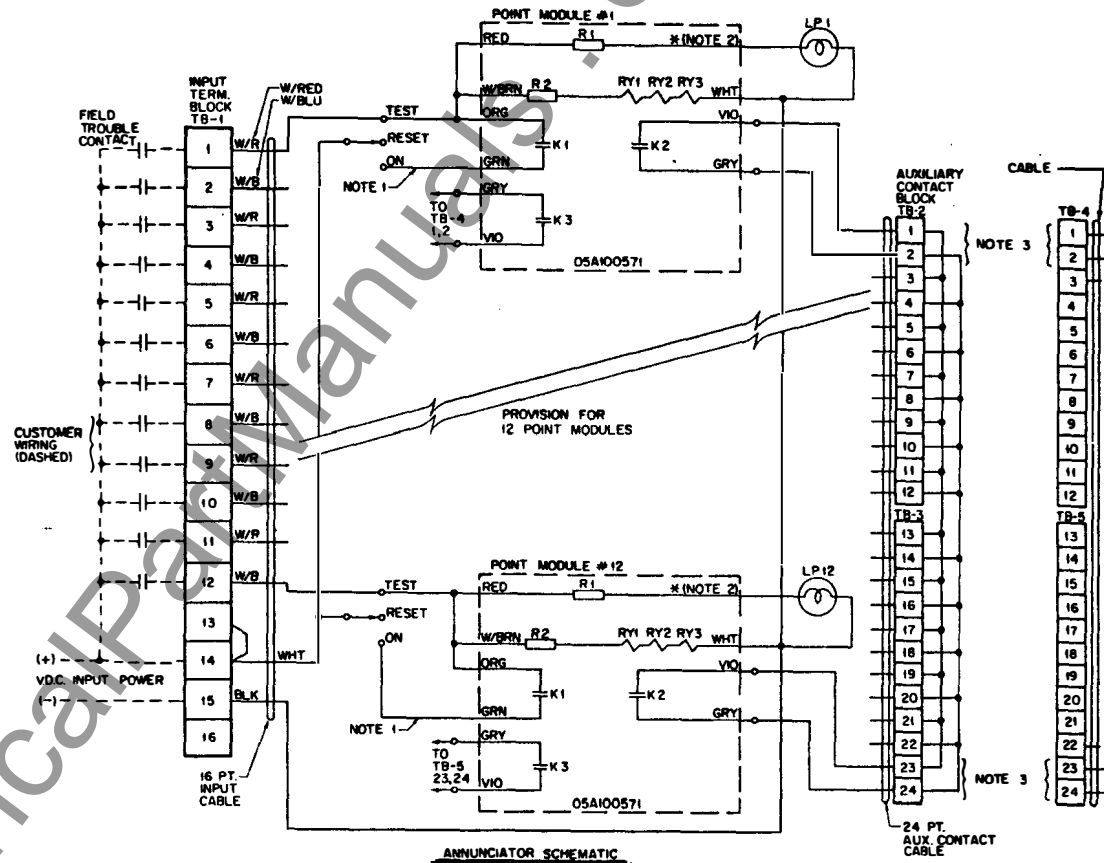
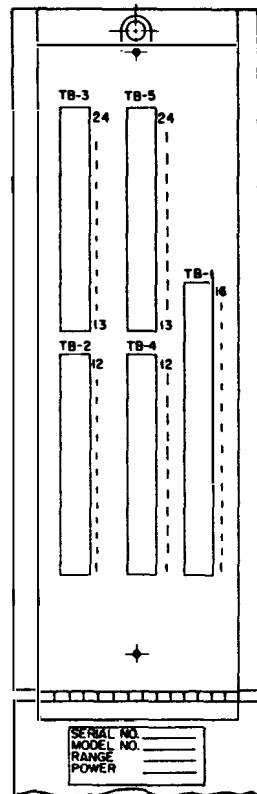
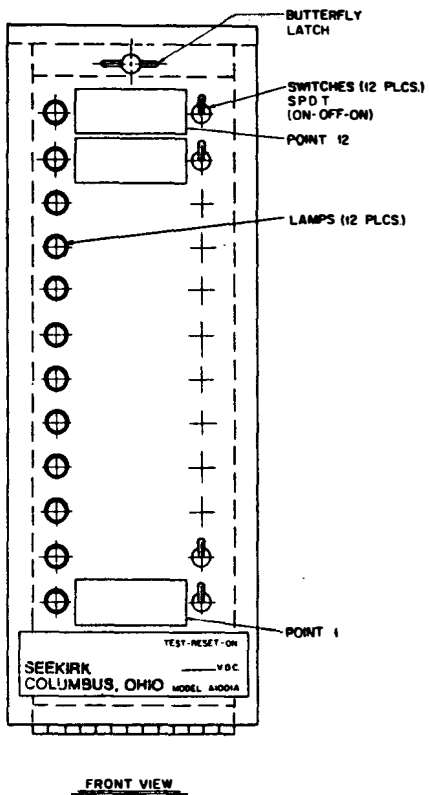

NOTES:

(1) FOR SEQUENCE SELECTION

- A) REMOVE GRN WIRE FOR SEQUENCE "A"
- B) RETAIN GRN WIRE FOR SEQUENCE "B"

	'A' SEQ. (FOLLOW THE CONTACT)		'B' SEQ. (LOCK-ON)	
	LAMP	AUX. CONTACT	LAMP	AUX. CONTACT
NORMAL	OFF	OPEN	OFF	OPEN
ALARM	ON	CLOSED	ON	CLOSED
RETURN TO NORMAL	OFF	OPEN	ON	CLOSED
RESET BEFORE RETURN TO NORMAL	ON	CLOSED	ON	CLOSED
RESET AFTER RETURN TO NORMAL	—	—	OFF	OPEN

(2) MODULES PROVIDED AS FOLLOWS:

VOLT	MODULE TYPE	COLOR CODE	PANEL LAMPS
125 V.D.C.	9114 2N	BLU	120 PSB
48 V.D.C.	9113 2N	YEL	48 PSB
24 V.D.C.	9112 2N	GRN	24 PSB

(3) CONTACT RATING (RESISTIVE LOAD)

VOLTS - 350 V.D.C. (MIN. BREAKDOWN)
 WATTS - 15 W MAX.
 VOLTS - 250 V.D.C. (MAX. SWITCHING)
 AMPS - 2.0 AMPS MAX. (GATING & CARRY)
 FOR 50 V.D.C. LOAD, MAX. I = 0.3 AMPS
 FOR 130 V.D.C. LOAD, MAX. I = 115 MA.

A RESISTOR SHOULD BE CONNECTED IN SERIES W/ THE CONTACT TO REDUCE THE SURGE FOR LAMPS OR CAPACITIVE LOADS. FOR INDUCTIVE LOAD, SUCH AS A RELAY OR BELL, AN APPROPRIATE DIODE SHOULD BE CONNECTED IN PARALLEL W/ THE LOAD INDUCTIVE TRANSIENT VOLTAGE SUPPRESSION.

(4)

VOLT	POINT MODULE	R1	R2
125 V.D.C.	9114 2N	15K-1W	10K-3W
48 V.D.C.	9113 2N	220-1W	33K-1W
24 V.D.C.	9112 2N	47-1W	15K-1/2W

REFERENCE - DRAWING 02DI00498

MODEL A1001A-INSTALLATION & WIRING

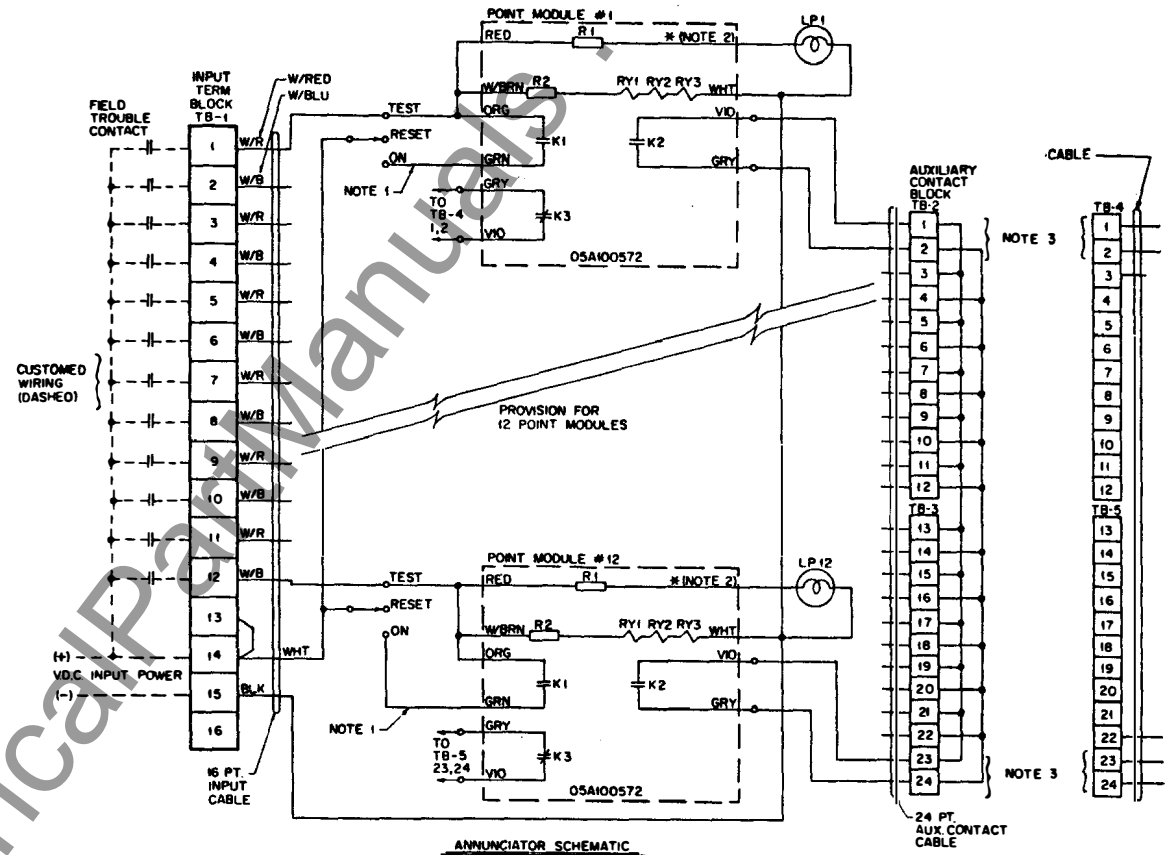
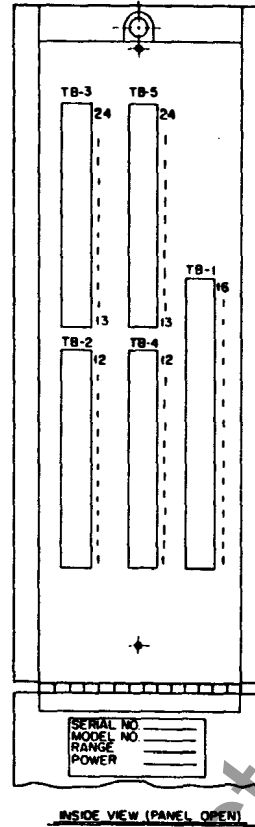
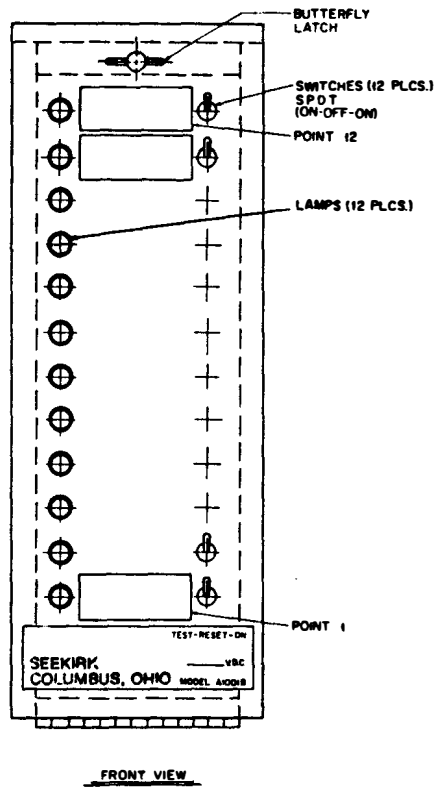

NOTES:

(1) FOR SEQUENCE SELECTION

- A) REMOVE GRN WIRE FOR SEQUENCE "A"
- B) RETAIN GRN WIRE FOR SEQUENCE "B"

	'A' SEQ. (FOLLOW THE CONTACT)		'B' SEQ. (LOCK-ON)	
	LAMP	AUX. CONTACT	LAMP	AUX. CONTACT
NORMAL	OFF	RY1, RY2 OPEN RY3 CLOSED	OFF	RY1, RY2 OPEN RY3 CLOSED
ALARM	ON	RY1, RY2 CLOSED RY3 OPEN	ON	RY1, RY2 CLOSED RY3 OPEN
RETURN TO NORMAL	OFF	RY1, RY2 OPEN RY3 CLOSED	ON	RY1, RY2 OPEN RY3 CLOSED
RESET AFTER RETURN TO NORMAL	---	---	OFF	RY1, RY2 OPEN RY3 CLOSED
RESET BEFORE RETURN TO NORMAL	ON	RY1, RY2 CLOSED RY3 OPEN	ON	RY1, RY2 CLOSED RY3 OPEN

(2) MODULES PROVIDED AS FOLLOWS:

VOLTS	MODULE TYPE	COLOR CODE	PANEL LAMPS
125 V.D.C.	914 ZNB	BLU	120 PSB
48 V.D.C.	913 ZNB	YEL	48 PSB
24 V.D.C.	912 ZNB	GRN	24 PSB

(3) CONTACT RATING (RESISTIVE LOAD)

- VOLTS - 350 V.D.C. (MIN. BREAKDOWN)
- WATTS - 15 W MAX.
- VOLTS - 250 V.D.C. (MAX. SWITCHING)
- AMPS - 2.0 AMPS MAX. (GATING & CARRY)
- FOR 50 V.D.C. LOAD, MAX. I = 0.3 AMPS
- FOR 130 V.D.C. LOAD, MAX. I = 115 MA

A RESISTOR SHOULD BE CONNECTED IN SERIES W/ THE CONTACT TO REDUCE THE SURGE FOR LAMPS OR CAPACITIVE LOADS. FOR INDUCTIVE LOAD, SUCH AS A RELAY OR BELL, AN APPROPRIATE DIODE SHOULD BE CONNECTED IN PARALLEL W/ THE LOAD INDUCTIVE TRANSIENT VOLTAGE SUPPRESSION.

(4)

VOLT	POINT MODULE	R1	R2
125 V.D.C.	9114 ZNB	15K-1W	10K-3W
48 V.D.C.	9113 ZNB	220-1W	3.3K-1W
24 V.D.C.	9112 ZNB	47-1W	1.5K-1/2W

REFERENCE - DRAWING 02D100500

MODEL A100IB - INSTALLATION & WIRING

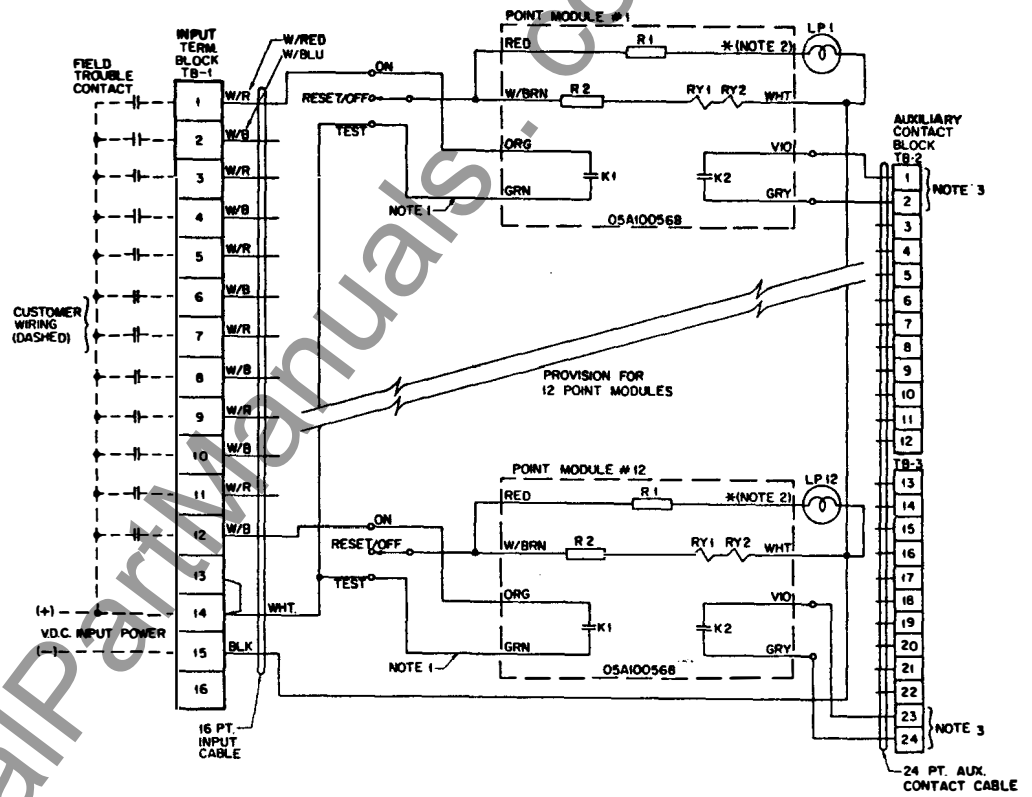
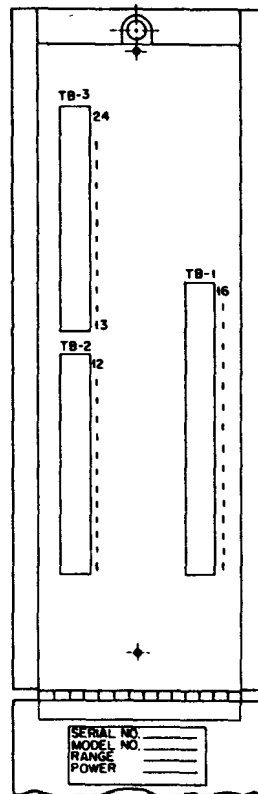
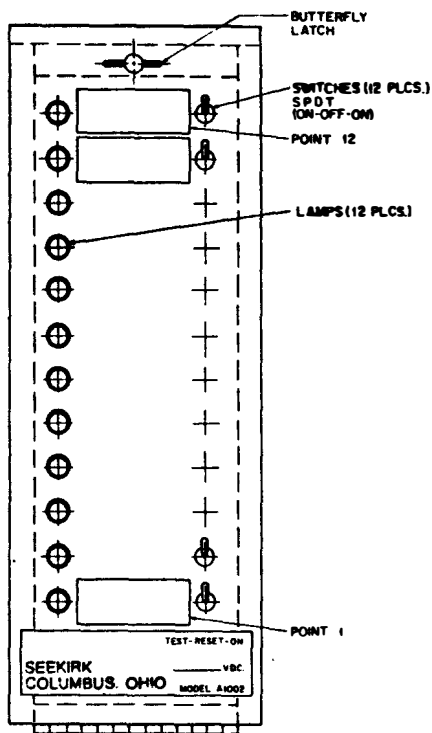

NOTES:

(1) FOR SEQUENCE SELECTION

A) REMOVE GRN WIRE FOR SEQUENCE "A".
 B) RETAIN GRN WIRE FOR SEQUENCE "B".

	'A' SEQ. (FOLLOW THE CONTACT)		'B' SEQ. (LOCK-ON)	
	LAMP	AUX. CONTACT	LAMP	AUX. CONTACT
NORMAL	OFF	OPEN	OFF	OPEN
ALARM	ON	CLOSED	ON	CLOSED
RETURN TO NORMAL	OFF	OPEN	ON	CLOSED
RESET AFTER RETURN TO NORMAL	---	---	OFF	OPEN
RESET BEFORE RETURN TO NORMAL	OFF	OPEN	OFF	OPEN

(2) MODULES PROVIDED AS FOLLOWS:

VOLT	MODULE TYPE	COLOR CODE	PANEL LAMPS
125 VDC	9H4 PA	BLU	12D PSB
48 VDC	9H3 PA	YEL	48 PSB
24 VDC	9H2 PA	GRN	24 PSB

(3) CONTACT RATING (RESISTIVE LOAD)

VOLTS - 350 VDC (MIN. BREAKDOWN)
 WATTS - 15 W. MAX.
 VOLTS - 250 VDC (MAX. SWITCHING)
 AMPS - 2.0 AMPS MAX. (GATING & CARRY)
 FOR 50 VDC LOAD, MAX. I = 0.3 AMPS
 FOR 130 VDC LOAD, MAX. I = 115 MA

A RESISTOR SHOULD BE CONNECTED IN SERIES W/ THE CONTACT TO REDUCE THE SURGE FOR LAMPS OR CAPACITIVE LOADS. FOR INDUCTIVE LOAD, SUCH AS A RELAY OR BELL, AN APPROPRIATE DIODE SHOULD BE CONNECTED IN PARALLEL W/ THE LOAD INDUCTIVE TRANSIENT VOLTAGE SUPPRESSION.

(4)

VOLT	POINT MODULE	R1	R2
125 VDC	9H4 PA	1.5K-1W	10K-3W
48 VDC	9H3 PA	220-1W	3.3K-1W
24 VDC	9H2 PA	47-1W	1.5K-V2W

REFERENCE - DRAWING 02DI00515

MODEL A1002 - INSTALLATION & WIRING

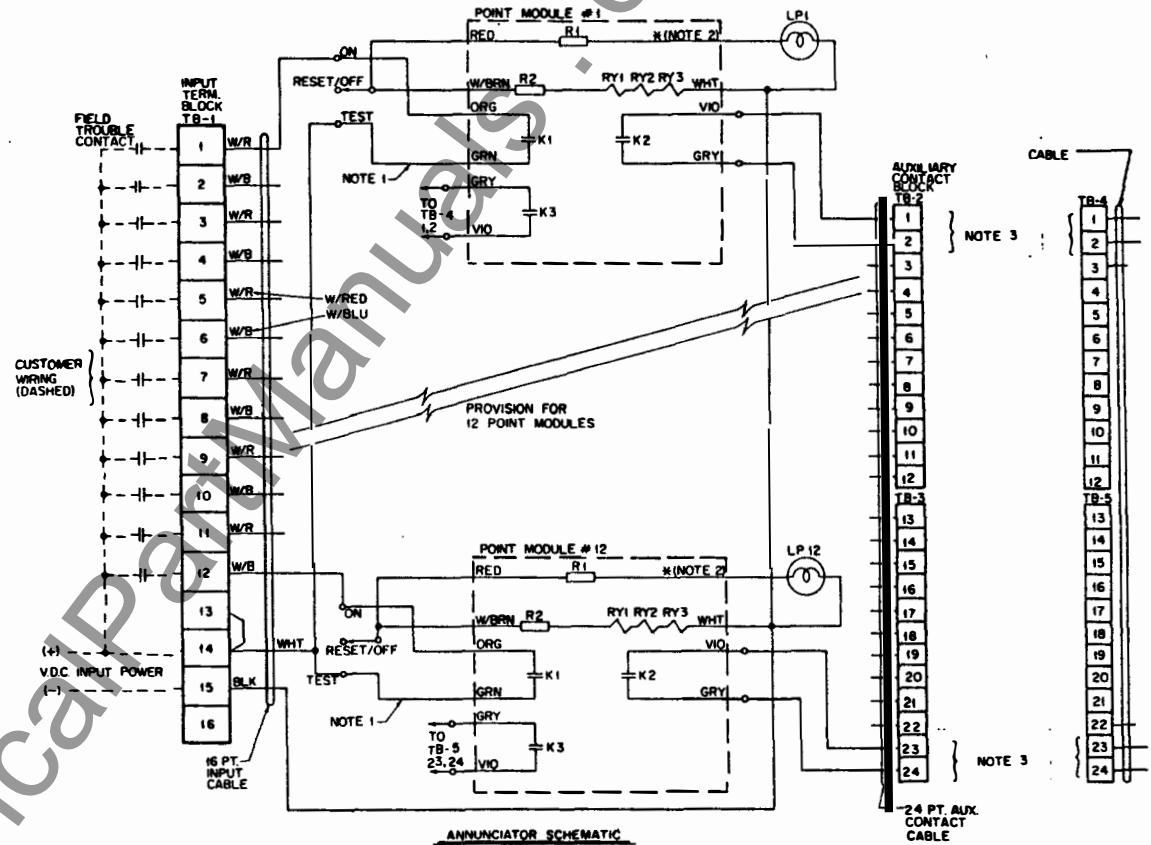
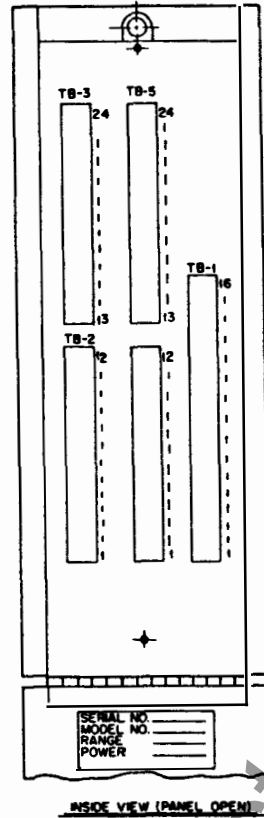
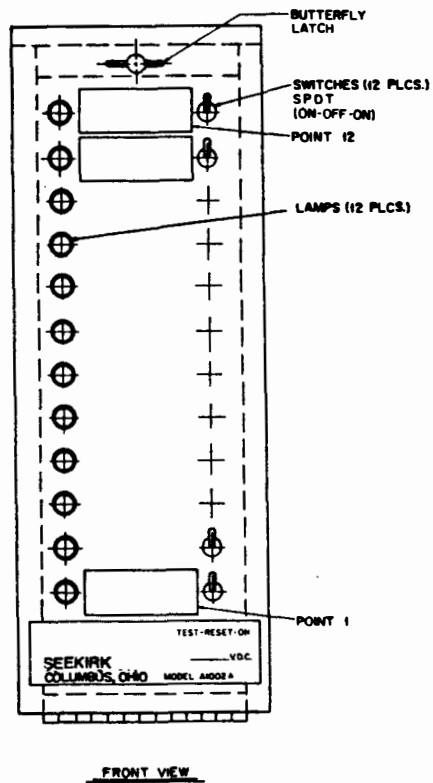

NOTES:

- (1) FOR SEQUENCE SELECTION
 A) REMOVE GRN WIRE FOR SEQUENCE "A".
 B) RETAIN GRN WIRE FOR SEQUENCE "B".

	'A' SEQ. (FOLLOW THE CONTACT)		'B' SEQ. (LOCK-ON)	
	LAMP	AUX CONTACT	LAMP	AUX CONTACT
NORMAL	OFF	RY1, RY2 OPEN	OFF	OPEN
ALARM	ON	RY1, RY2 CLOSED	ON	CLOSED
RETURN TO NORMAL	OFF	RY1, RY2 OPEN	ON	CLOSED
RESET AFTER RETURN TO NORMAL	---	---	OFF	OPEN
RESET BEFORE RETURN TO NORMAL	OFF	RY1, RY2 OPEN	OFF	RY1, RY2 OPEN
RETURN TO NORMAL	OFF	RY3	OFF	RY3

(2) MODULES PROVIDED AS FOLLOWS:

VOLT	MODULE TYPE	COLOR CODE	PANEL LAMPS
125 V.D.C.	9H4 2N	BLU	120 PSB
48 V.D.C.	9H3 2N	YEL	48 PSB
24 V.D.C.	9H2 2N	GRN	24 PSB

(3) CONTACT RATING (RESISTIVE LOAD)

- VOLTS - 350 V.D.C. (MIN. BREAKDOWN)
- WATTS - 15 W MAX.
- VOLTS - 250 V.D.C. (MAX. SWITCHING)
- AMPS - 2.0 AMPS MAX. (GATING & CARRY)
- FOR 50 V.D.C. LOAD, MAX. I = 0.3 AMPS
- FOR 130 V.D.C. LOAD, MAX. I = 115 MA.

A RESISTOR SHOULD BE CONNECTED IN SERIES W/ THE CONTACT TO REDUCE THE SURGE FOR LAMPS OR CAPACITIVE LOADS. FOR INDUCTIVE LOAD, SUCH AS A RELAY OR BELL, AN APPROPRIATE DIODE SHOULD BE CONNECTED IN PARALLEL W/ THE LOAD INDUCTIVE TRANSIENT VOLTAGE SUPPRESSION.

(4)

VOLT	POINT MODULE	R1	R2
125 V.D.C.	9H4 2N	1.5K-1W	10K-3W
48 V.D.C.	9H3 2N	220-1W	3.3K-1W
24 V.D.C.	9H2 2N	47-1W	1.5K-1/2W

REFERENCE - DRAWING 02D101126

MODEL A1002A - INSTALLATION & WIRING

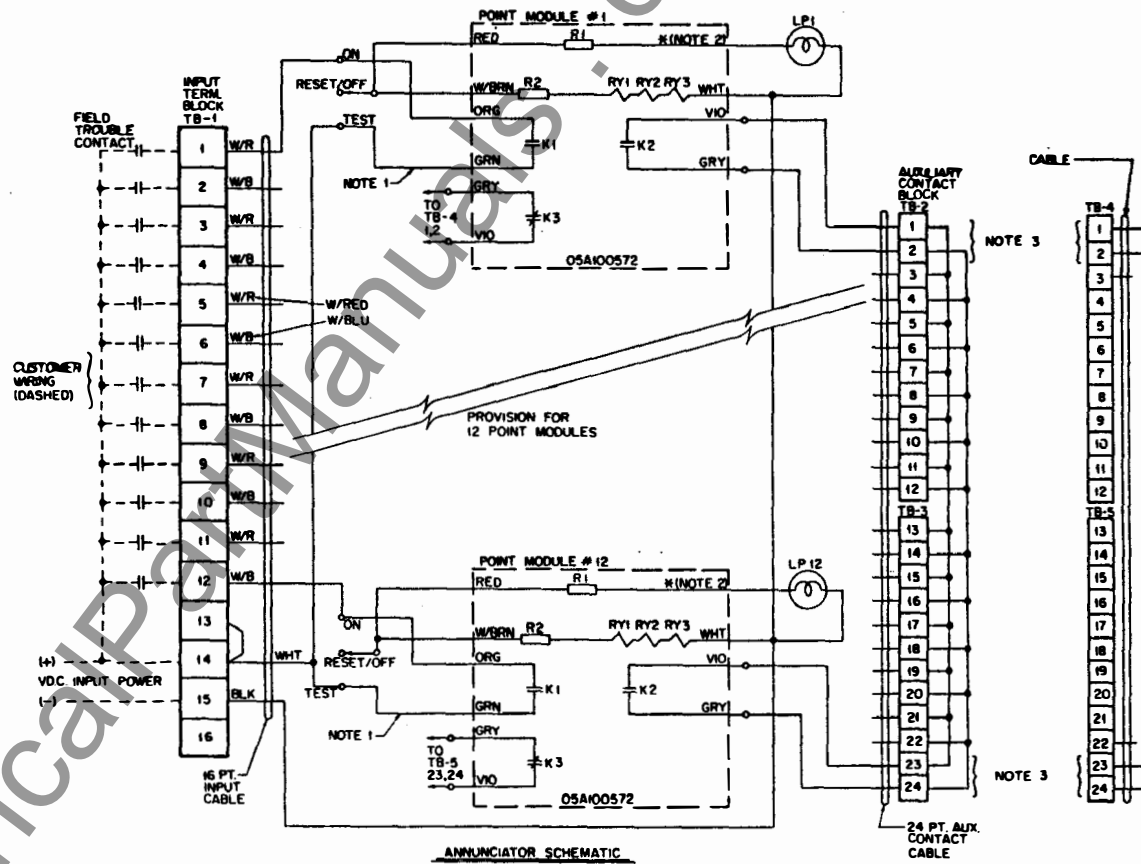
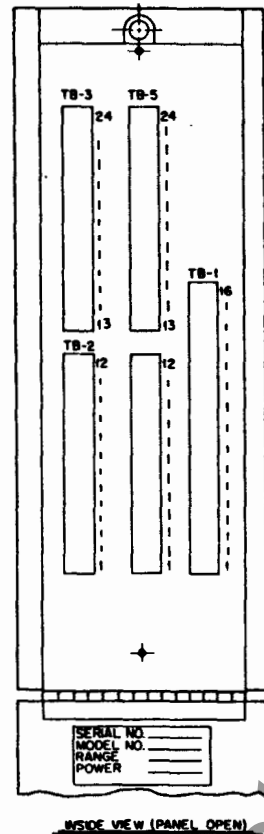
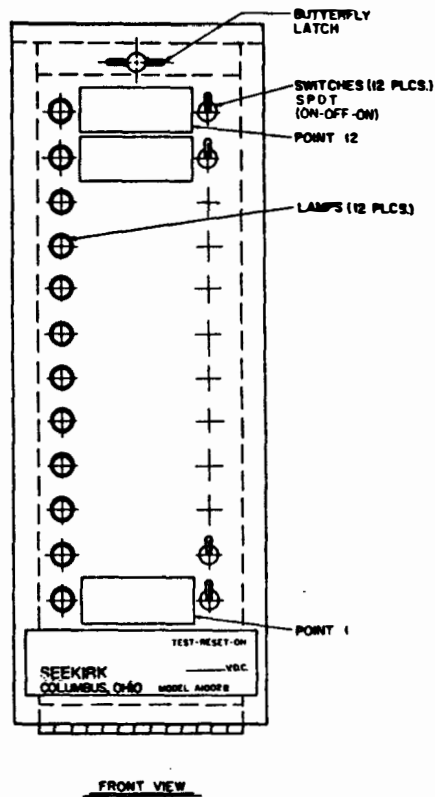

NOTE:

(1) FOR SEQUENCE SELECTION

A) REMOVE GRN WIRE FOR SEQUENCE "A".
B) RETAIN GRN WIRE FOR SEQUENCE "B".

	'A' SEQ. (FOLLOW THE CONTACT)		'B' SEQ. (LOCK-ON)	
	LAMP	AUX CONTACT	LAMP	AUX CONTACT
NORMAL	OFF	RY1 RY2 OPEN RY3 CLOSED	OFF	OPEN
ALARM	ON	RY1 RY2 CLOSED RY3 OPEN	ON	CLOSED
RETURN TO NORMAL	OFF	RY1 RY2 OPEN RY3 CLOSED	ON	CLOSED
RESET AFTER	---	---	OFF	OPEN
RETURN TO NORMAL	---	---	---	---
RESET BEFORE	---	---	---	---
RETURN TO NORMAL	OFF	RY1 RY2 OPEN RY3 CLOSED	OFF	RY1 RY2 OPEN RY3 CLOSED

(2) MODULES PROVIDED AS FOLLOWS:

VOLT	MODULE TYPE	COLOR CODE	PANEL LAMPS
125 VDC.	9H4 2NB	BLU	120 PSB
48 VDC.	9H3 2NB	YEL	48 PSB
24 VDC.	9H2 2NB	GRN	24 PSB

(3) CONTACT RATING (RESISTIVE LOAD)

VOLTS - 350 VDC. (MIN. BREAKDOWN)
WATTS - 15 W. MAX.
VOLTS - 250 VDC. (MAX. SWITCHING)
AMPS - 2.0 AMPS MAX. (GATING & CARRY)
FOR 50 VDC. LOAD, MAX. I = 0.3 AMPS
FOR 130 VDC. LOAD, MAX. I = 115 MA

A RESISTOR SHOULD BE CONNECTED IN SERIES W/ THE CONTACT TO REDUCE THE SURGE FOR LAMPS OR CAPACITIVE LOADS. FOR INDUCTIVE LOAD, SUCH AS A RELAY OR BELL, AN APPROPRIATE DIODE SHOULD BE CONNECTED IN PARALLEL W/ THE LOAD INDUCTIVE TRANSIENT VOLTAGE SUPPRESSION.

(5)

VOLT	POINT MODULE	R1	R2
125 VDC.	9H4 2NB	1.5K-1W	10K-3W
48 VDC.	9H3 2NB	220-1W	3.3K-1W
24 VDC.	9H2 2NB	47-1W	1.5K-1/2W

REFERENCE - DRAWING 02D100497

MODEL A1002B - INSTALLATION & WIRING

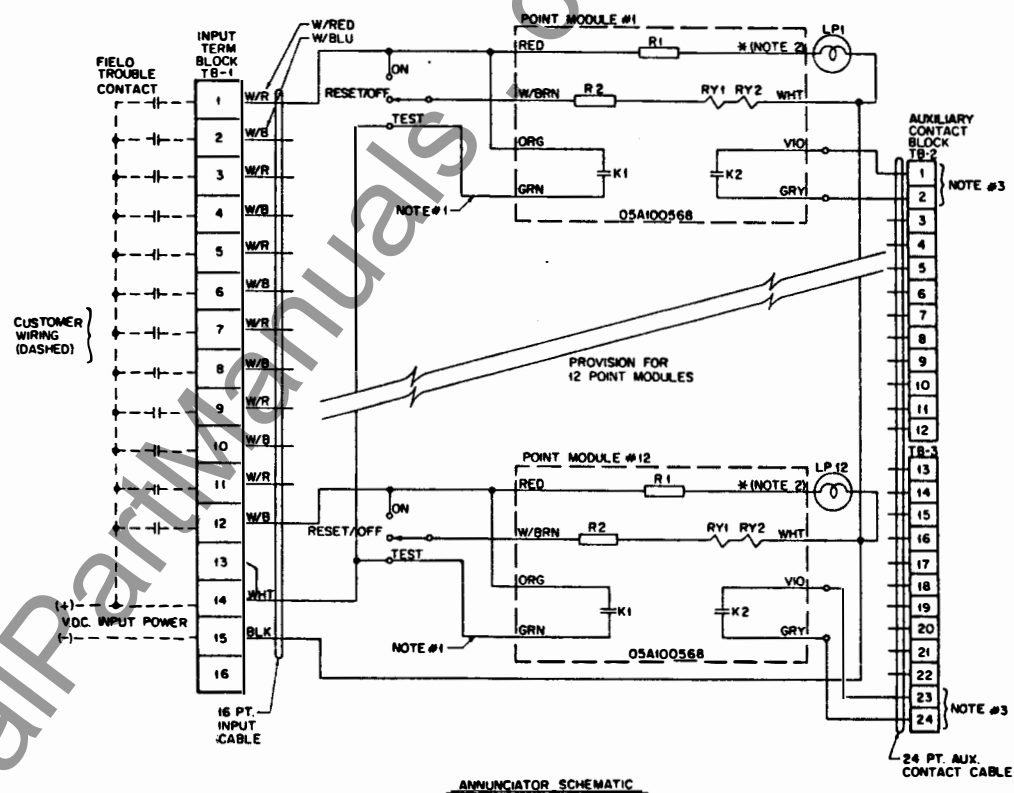
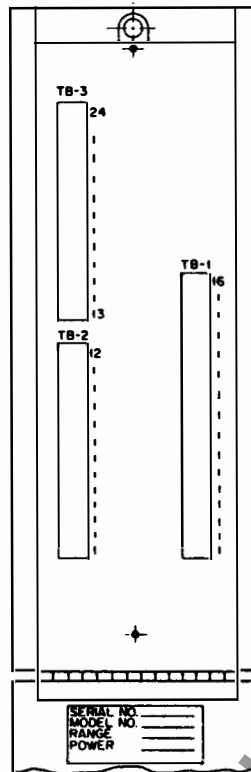
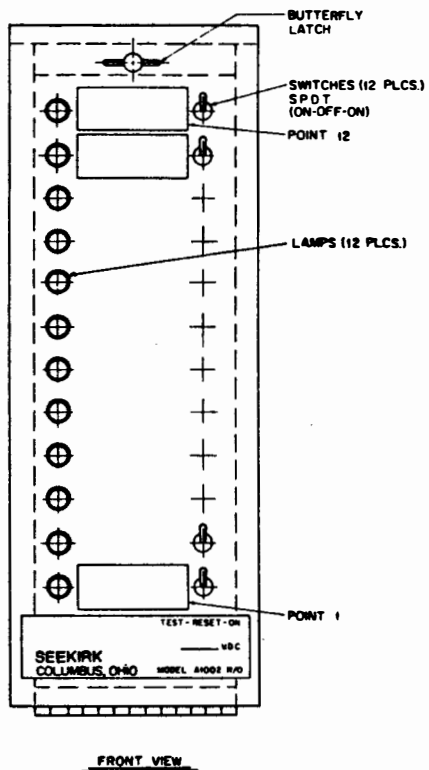

NOTES:

- (1) FOR SEQUENCE SELECTION
 A) REMOVE GRN WIRE FOR SEQUENCE "A"
 B) RETAIN GRN WIRE FOR SEQUENCE "B"

	A' SEQ. (FOLLOW THE CONTACT)		B' SEQ. (LOCK-ON)	
	LAMP	AUX. CONTACT	LAMP	AUX. CONTACT
NORMAL	OFF	OPEN	OFF	OPEN
ALARM	ON	CLOSED	ON	CLOSED
RETURN TO NORMAL	OFF	OPEN	ON	CLOSED
RESET/OFF	OFF	OPEN	OFF	OPEN
RESET/OFF BEFORE RETURN TO NORMAL	ON	OPEN	ON	OPEN

(2) MODULES PROVIDED AS FOLLOWS:

VOLT	MODULE TYPE	COLOR CODE	PANEL LAMPS
125 V.D.C.	9114 PA	BLU	120 PSB
48 V.D.C.	9113 PA	YEL	48 PSB
24 V.D.C.	9112 PA	GRN	24 PSB

(3) CONTACT RATING (RESISTIVE LOAD)

VOLTS - 350 V.D.C. (MIN. BREAKDOWN)
 WATTS - 15 W MAX.
 VOLTS - 250 V.D.C. (MAX. SWITCHING)
 AMPS - 2.0 AMPS MAX. (GATING & CARRY)
 FOR 50 V.D.C. LOAD, MAX. I = 0.3 AMPS
 FOR 130 V.D.C. LOAD, MAX. I = 115 MA.

A RESISTOR SHOULD BE CONNECTED IN SERIES W/ THE CONTACT TO REDUCE THE SURGE FOR LAMPS OR CAPACITIVE LOADS. FOR INDUCTIVE LOAD, SUCH AS A RELAY OR BELL, AN APPROPRIATE DIODE SHOULD BE CONNECTED IN PARALLEL W/ THE LOAD INDUCTIVE TRANSIENT VOLTAGE SUPPRESSION.

(4)

VOLT	POINT MODULE	R1	R2
125 V.D.C.	9114 PA	1.5K-1W	10K-3W
48 V.D.C.	9113 PA	220-1W	33K-1W
24 V.D.C.	9112 PA	47-1W	1.5K-1/2W

REFERENCE - DRAWING 02D100519

MODEL A1002 R/O - INSTALLATION & WIRING

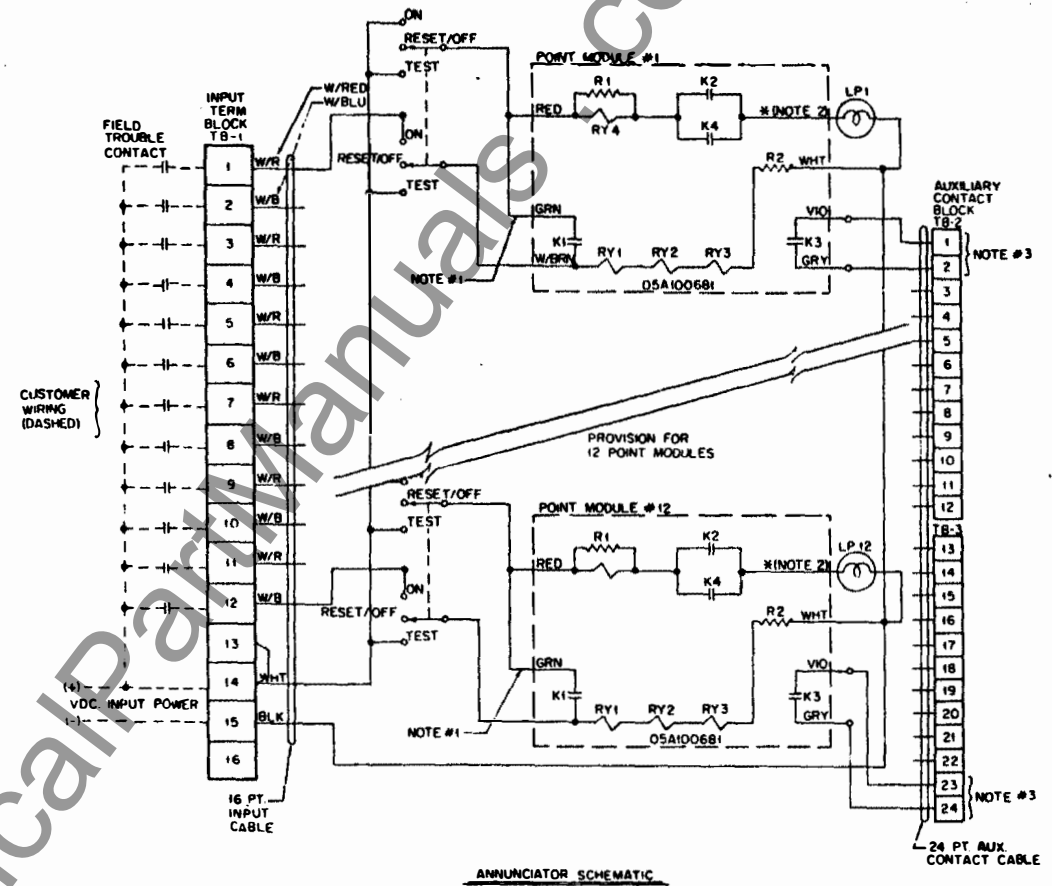
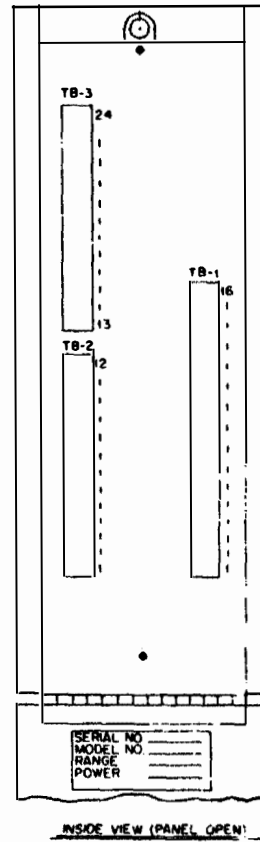
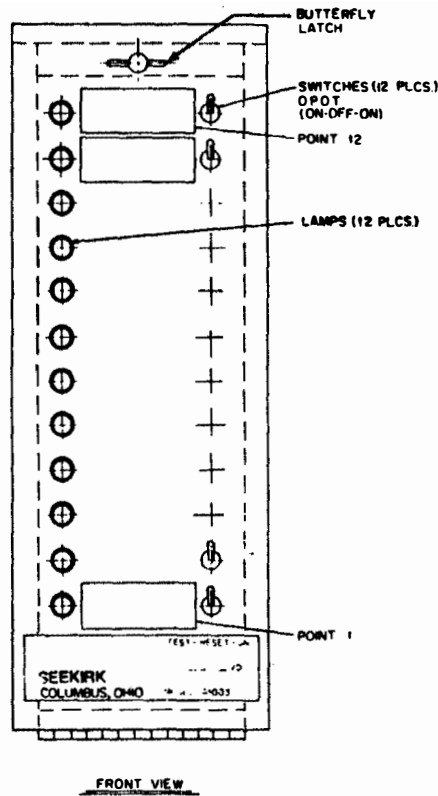

NOTES:

- (1) FOR SEQUENCE SELECTION
- A) REMOVE GRN WIRE FOR SEQUENCE "A".
- B) RETAIN GRN WIRE FOR SEQUENCE "B".

	A' SEQ. (FOLLOW THE CONTACT)		B' SEQ. (LOCK-ON)	
	LAMP	AUX. CONTACT	LAMP	AUX. CONTACT
NORMAL	OFF	OPEN	OFF	OPEN
ALARM	ON	CLOSED	ON	CLOSED
RETURN TO NORMAL	ON	OPEN	ON	CLOSED
RESET/OFF	OFF	OPEN	OFF	OPEN
RESET/OFF BEFORE RETURN TO NORMAL	ON	CLOSED	ON	CLOSED

(2) MODULES PROVIDED AS FOLLOWS:

VOLT	MODULE TYPE	COLOR CODE	PANEL LAMPS
125 VDC	9114 RA	BLU	120 PSB
48 VDC	9113 RA	YEL	48 PSB
24 VDC	9112 RA	GRN	24 PSB

- (3) CONTACT RATING (RESISTIVE LOAD):
- VOLTS - 350 VDC (MIN. BREAKDOWN)
- WATTS - 15 W MAX.
- VOLTS - 250 VDC (MAX. SWITCHING)
- AMPS - 20 AMPS MAX. (GATING & CARRY)
- FOR 50 VDC LOAD, MAX I = 0.3 AMPS
- FOR 130 VDC LOAD, MAX I = 115 MA

A RESISTOR SHOULD BE CONNECTED IN SERIES W/ THE CONTACT TO REDUCE THE SURGE FOR LAMPS OR CAPACITIVE LOADS. FOR INDUCTIVE LOAD, SUCH AS A RELAY OR BELL, AN APPROPRIATE DIODE SHOULD BE CONNECTED IN PARALLEL W/ THE LOAD INDUCTIVE TRANSIENT VOLTAGE SUPPRESSION.

(4)

VOLT	POINT MODULE	R1	R2
125 VDC	9114 RA	680-1/2W	10K-3W
48 VDC	9113 RA	220-1/2W	33K-1W
24 VDC	9112 RA	150-1/2W	15K-1/2W

REFERENCE - DRAWING 02D100682

MODEL A1003 - INSTALLATION & WIRING