

ABB Power Distribution, Inc.

Type HK II ANSI Rated Vacuum & SF₆ Gas Medium Voltage Metal-Clad Switchgear

Bulletin 3.2.4 - IC

5KV - 250/350MVA 1200, 2000 AND 3000 A
7.5KV - 500MVA 1200, 2000 AND 3000 A
15KV - 500/750/1000MVA 1200, 2000 AND 3000 A
27KV - 500/750/1000MVA 1200 AND 2000A



TABLE OF CONTENTS

Introduction	2	Standard Switchgear Arrangements (One & Two High) 5KV-350, 7.5KV-500, 15KV-500, 750 & 1000, 27KV-500, 750 & 1000MVA	14
Vacuum Type Circuit Breaker Characteristics	3	Standard Switchgear Arrangements (One High) 5KV-250MVA	23
SF ₆ Gas Type Circuit Breaker Characteristics	4	Metal-Clad Switchgear Application Guide	26
SF ₆ and Vacuum Type Circuit Breaker Features	5	Typical 5, 7.5, 15 and 27KV HK II Metal-Clad Switchgear Specifications	37
Circuit Breaker Compartment Features	6	Breaker and Switchgear Weights	39
Typical Circuit Breaker Internal Schematic Diagrams	8		
Additional Features and Options	9		
Insulation System Quality	13		

ABB TOTALLY ANSI RATED TYPE HK II METAL-CLAD SWITCHGEAR COMPLETELY DEDICATED TO SAFETY, RELIABILITY, FLEXIBILITY, AND VALUE.

ABB with proven expertise in the design, testing and manufacture of both vacuum and SF₆ Power Interrupters offers *customer preference* of either technology in one Compact

Modern Switchgear Assembly. ABB Type HK II Metal-Clad Switchgear combines the Type HK traditional design excellence with expanded and improved *customer preference* built-in features, benefits and options.

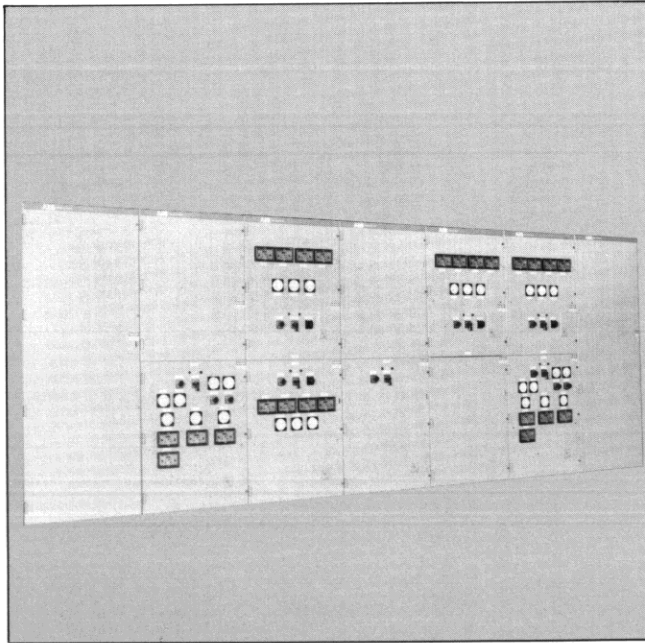

5, 7.5, 15 & 27KV TWO-HIGH CONSTRUCTION

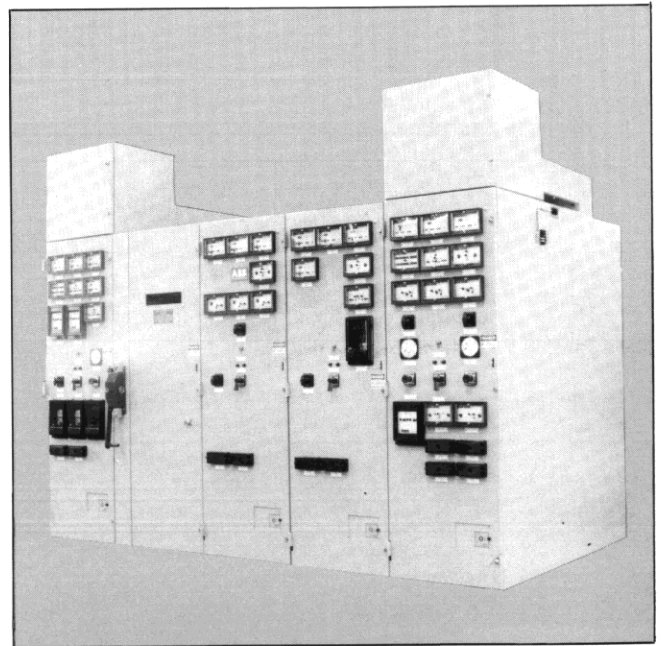

5KV 250 MVA 26" WIDE ONE-HIGH CONSTRUCTION WITH PT'S IN OVERHEAD TRUNIONS

EXPRESS YOUR PREFERENCE AND BUY ABB METAL-CLAD SWITCHGEAR

Three Individual-Phase Power Vacuum Interrupters perform the arc interruption duty in a sealed-for-life vacuum environment. Vacuum Interrupters are constructed of an insulating ceramic cylinder (2), fusion welded to metal end caps (1), enclosing a stationary contact (3), a moving contact (4), a metallic bellows (6) and a metallic shield (5), in a vacuum environment (7). The flexing of the metallic bellows allows contact movement without the necessity of moving seals. The contact material vaporized during the arcing period is rapidly recombined on the contact surface or collected by the metallic shield following current interruption at natural current zero. The vacuum inside the interrupter is approximately 10^{-6} torr.

While in the other technologies the arc quenching efficiency is based on low ionic mobility, in the ideal vacuum it is based on the absence of the dielectric breakdown phenomenon.

Contacts play a fundamental role in the operation of a vacuum circuit breaker with the material and contact arrangement influencing the rapidity with which the arc passes from a constricted status due to high metal vapor generation, to a diffused status which is the basic factor for proper arc quenching. The materials with which the contacts are made must possess low vapor tension in order not to pass too rapidly at low currents to the diffused status, as such a condition could, in fact, cause voltage surges associated with arc instability. Chrome copper contacts are the most suitable as they have been proven by exhaustive testing to reduce chopped currents to values of five amperes or less. The corresponding level of overvoltages is well within the withstand capability of the circuit breaker and switchgear.

A typical oscillogram in Figure 1 shows the basic parameters of the interrupting phenomenon.

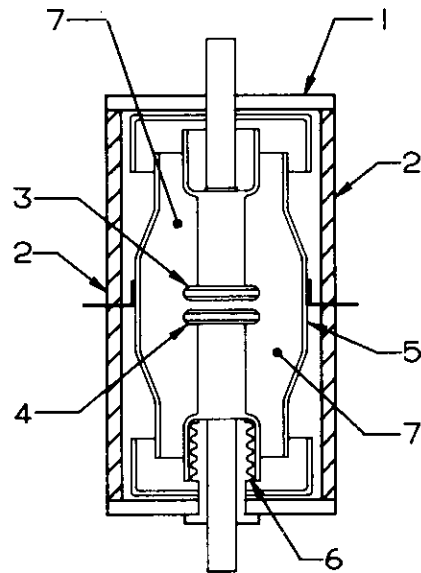

VACUUM INTERRUPTER CROSS SECTION

The most significant characteristics of vacuum power circuit breakers are:

- Extended life at full short circuit breaking current.
- Time proven simple low energy operating mechanism.
- Three cycle interrupting time.
- Quiet operation.
- Interruption in a controlled environment.
- All arcing products contained within the interrupter.
- Reduced overall dimensions and weights.

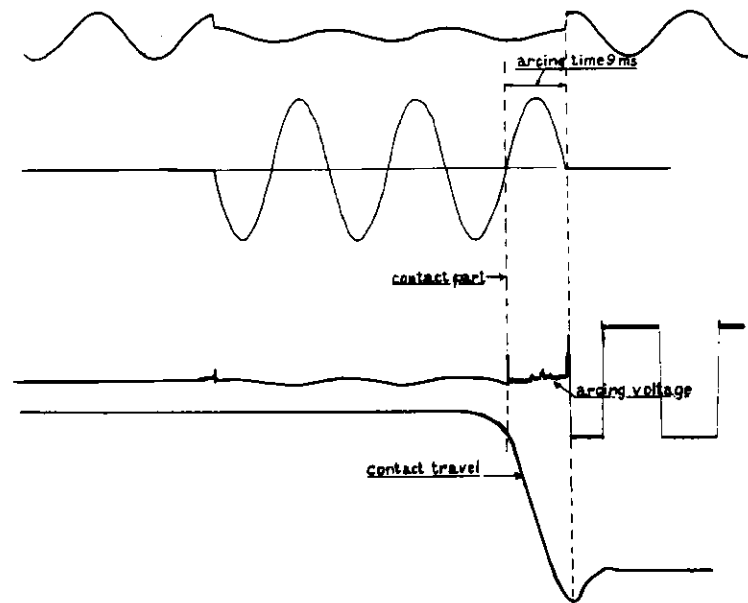

Fig. 1 Vacuum circuit breaker:
Oscillogram of first phase interrupted.

Three Individual Phase SF₆ Power Interrupters perform the arc interruption duty in a factory sealed SF₆ gas environment. SF₆ interrupters are constructed of an insulating double layer fiberglass and epoxy resin cylinder (1) with internal surfaces protected against the effects of decomposed SF₆, sealed to a metal housing (10) with double o-ring gaskets (11) enclosing a stationary main (2) and arcing (3) contact, a moving main (4) and arcing (5) contact, a sliding current transfer contact (7), an insulating push rod (9), operating crank (12), a system of pistons (8), a filling valve (14), and two separate pressure switches (13). Double o-rings provide a highly effective seal for the rotating shaft.

Upon contact opening the arc heats and ionizes the SF₆ gas which flows away from the arc zone being replaced with a rapid flow of cool SF₆ gas supplied by the pistons. The high dielectric SF₆ gas with exceptional arc quenching capacity brings about interruption at the first reasonable current zero with negligible over-voltage. The normal SF₆ pressure is 3.4 bars absolute (approximately 35 PSI gauge). Full dielectric and full interrupter ratings are maintained down to 1.6 bars absolute (approximately 9 PSI gauge). Full load breaking current and 78% of full dielectric withstand is maintained down to 1.0 bar (approximately 0 gauge).

Two pressure switches each with a form C contact are supplied to monitor the SF₆ gas pressure. One switch operates at 2.2 bars (approximately 17 PSI gauge) for alarm purposes and the other switch operates at 1.7 bars (approximately 10 PSI gauge) and may be used to trip and lockout or similar functions at the user's discretion.

A typical oscillogram in Figure 2 illustrates the basic parameters of the interrupting phenomenon.

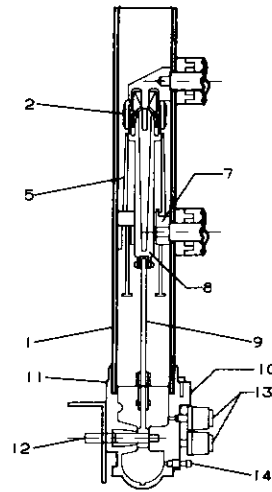

SF₆ INTERRUPTER CROSS SECTION

The most significant features of SF₆ circuit breakers are:

- Extended life at full short circuit breaking current.
- Reliable stored energy operating mechanism.
- Three cycle interrupting time.
- Quiet operation.
- Softer interruption in a controlled environment.
- All arc products contained within the interrupter.
- Reduced overall dimension and weight.
- Ability to monitor the integrity of the interrupter.
- Serviceable interrupters.

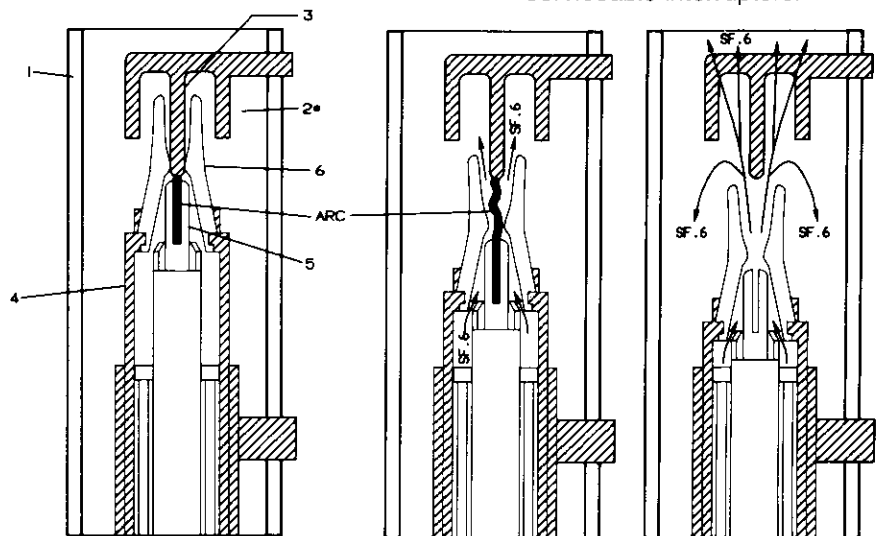

*MAIN CONTACT CLUSTER (FINGERS OMITTED FOR CLARIFICATION)

POLE ON ARCING CONTACTS SEPARATION

POLE DURING ARC QUENCHING SEQUENCE

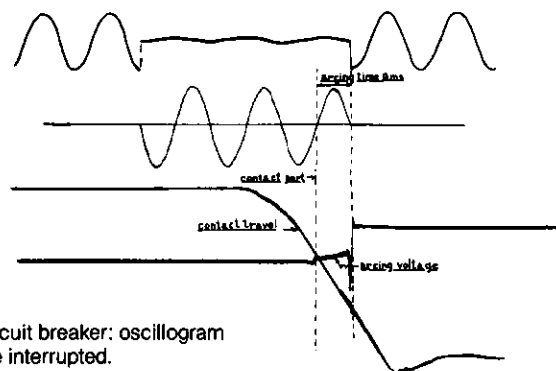
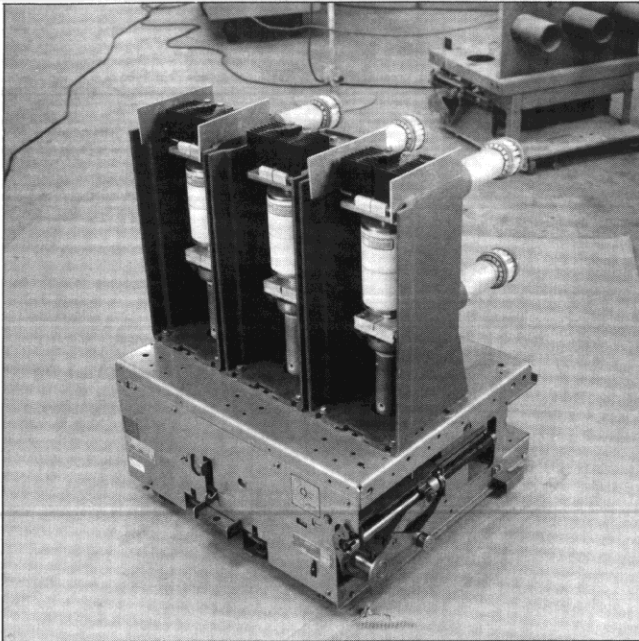
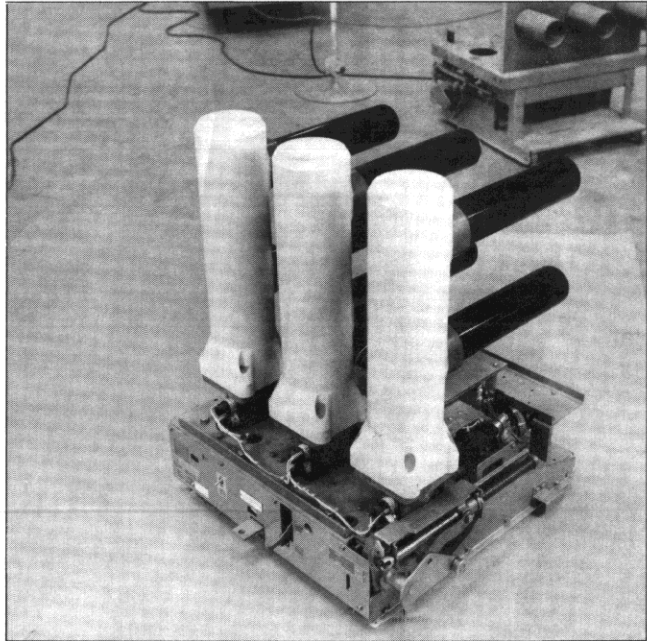

Fig. 2 SF₆ circuit breaker: oscillogram of first phase interrupted.



Type 15VHK 500, 2000 ampere circuit breaker (Personnel safety barrier has been removed).



Type 27GHK 500, 1200 ampere circuit breaker (Personnel safety barrier has been removed).

General

VHK Vacuum Circuit Breakers are ideal and economically feasible for general purpose circuits but may require surge suppression when serving motors or transformers with basic impulse levels (BIL) of lower rating than the switchgear.

GHK SF₆ Circuit Breakers provide softer interruptions usually eliminating any necessity for surge suppression except where exposure to lightning surges is possible.

GHK SF₆ Circuit Breakers offer the advantages of monitored gas pressure while in service providing knowledge at all times of interrupter integrity.

Both VHK Vacuum and GHK SF₆ Power Circuit Breakers each provide:

- Time proven, electrical and mechanical trip free, stored energy operating mechanisms.
- Closed door, four position, fully interlocked, horizontal drawout racking.
- Positive stop and latch in the connected, test and disconnected drawout positions.
- Reduced maintenance with factory sealed long life interrupters.
- Integral wheels for simplified handling.
- Insertion into or withdrawal from the lower compartment without a lifting device.
- Coordinated interference blocking to prevent insertion of improperly rated circuit breakers or ground and test devices.
- Secondary disconnects that automatically engage in test and connected drawout positions.
- Free floating and self aligning primary and secondary disconnects that are readily and safely available for inspection and servicing.
- Fully coordinated insulation systems.
- No discharge of arc products to the atmosphere.
- Easy access to critical component parts.
- Non-resettable accumulative operation counter.
- Emergency manual mechanical trip pushbutton.
- Emergency manual mechanical close release lever.
- Positive mechanism operated cell (MOC) switch actuator.
- Positive safety shutter actuator.
- Primary contact open-closed indicator.
- Stored energy spring charge indicator.
- Emergency manual stored energy spring charging capability.
- Automatic stored energy spring discharging when racking between disconnected and withdraw drawout positions.

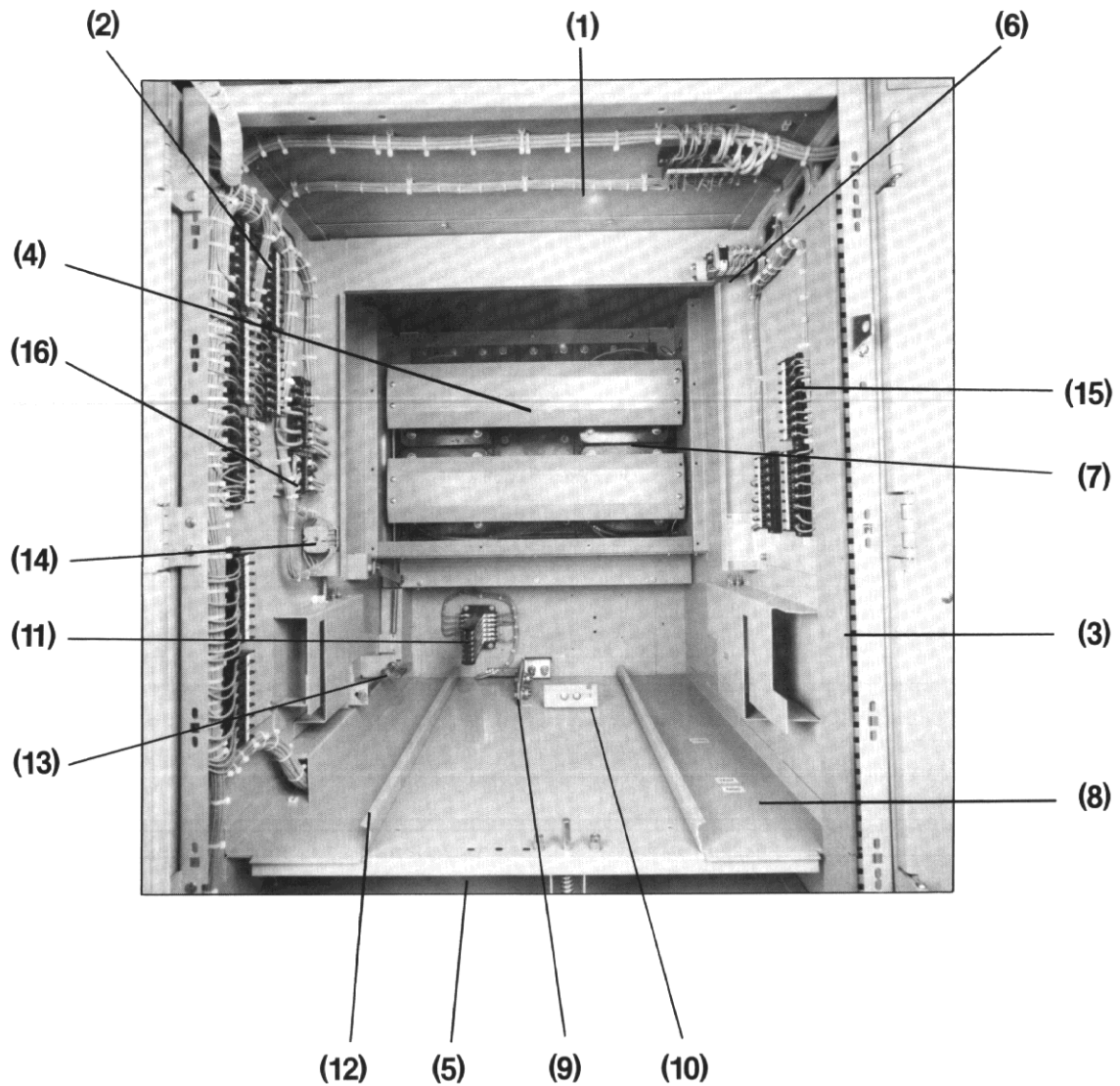

(1.) Low Voltage Compartment
With the power circuit breaker in the drawout connected position a segregated grounded metal enclosed low voltage compartment is formed providing access to the secondary wiring and devices without personnel exposure to primary voltage.

(2.) Secondary Wiring and Devices
Secondary wiring and all interconnected door mounted devices, control fuses, MOC and TOC auxiliary switches, terminal and CT shorting blocks are readily accessible in the low voltage compartment. Standard secondary wiring is extra flexible NEC Type SIS with uninsulated looped tongue lugs (Optional insulated looped tongue

lugs are available). Minimum standard wire size is No. 14 AWG. Standard AC and DC control bus is No. 8 AWG.

(3.) User Interconnecting Secondary Wiring
User interconnecting secondary wiring may enter from above or below. Either designated entry space will accommodate up to three 2 inch conduits. As applicable, an integral wireway is provided for routing user wiring to the low voltage compartment.

(4.) Safety Shutter

The stationary primary disconnects are covered by a grounded metal safety shutter whenever the power circuit breaker is out of the drawout connected position. The safety shutter is driven open as the power circuit breaker moves between drawout test and connected positions to permit mating of the primary disconnects. As an additional safeguard to the shutter closing springs cam action assures the complete closing of the safety shutter when the power circuit breaker is removed. A provision for padlocking the safety shutter in the closed position is standard.

(5.) Pull Out Fuse Blocks (POFB)

Two pole, 250V pull out fuse blocks for control circuit protection are readily and safely available. (not shown)

(6.) Truck Operated Cell (TOC) Switches

An optional eight contact TOC switch is available to provide connected/not connected drawout status of the power circuit breaker. Movement of the circuit breaker during racking between test and connected drawout positions causes a contact position change in the TOC switch. Normally open (a) and normally closed (b) contacts are equally divided. See page 36 for contact ratings.

(7.) Current Transformer (CT) Mounting

Current Transformers are of the toroidal type and can be mounted on both line and load primary bushings behind the shutter. Each primary bushing will accommodate up to two ANSI Standard Accuracy Class CT's or one special High Accuracy Class CT. Adding new CT's or changing CT ratios is easily and quickly performed without disturbing primary busses. See pages 35 and 36 for CT data.

(8.) Drawout Position Indicator

An indicator on the power circuit breaker points to an indicator on the circuit breaker compartment floor to clearly illustrate the drawout position. This indication can be observed through the access panel or with the circuit breaker compartment door open.

(9.) Grounding Contact

A copper ground bus rigidly connected to the switchgear ground bus system is engaged by a grounding contact on the drawout element to provide a maintained ground on the un-insulated portion of the drawout element whenever its secondary and/or primary disconnects are mated.

(10.) Interference Block

The Interference Block in the compartment mates with the interference angle on the power circuit breaker to accept insertion of correctly rated drawout elements and to reject insertion of incorrectly rated drawout elements.

(11.) Stationary Secondary Disconnects

The Stationary Secondary Disconnects automatically mate with the power circuit breakers moving secondary disconnects in the test and connected drawout positions to interconnect circuits for the spring charging motor, close and trip devices and indicating lights.

(12.) Dual Guide Rails

Floor mounted full length dual guide rails assure positive alignment of the power circuit breaker within its compartment to achieve the proper mating of all primary, secondary and grounding contacts.

(13.) MOC Switch Actuator

The cell mounted MOC switch actuator interfaces with the power circuit breaker operating mechanism linkage only in the drawout connected position. An optional MOC switch actuator is available to interface in both the drawout test and connected positions.

(14.) Mechanism Operated Cell (MOC) Switches

An eight contact MOC switch is supplied as standard to provide open-closed status of the power circuit breakers primary contacts. MOC switches are optionally available in sixteen and twenty-four contact configurations. Normally open (a) and normally closed (b) contacts are equally divided. See page 36 for contact ratings.

(15.) Terminal Blocks

Numbered eight point recessed screw type terminal blocks are mounted on stand off removable panels to prevent enclosure penetration by device mounting hardware. Terminal block points designated for user interconnections have one side of the block reserved for this purpose.

(16.) CT Shorting Terminal Blocks

A four point shorting type terminal block providing captive storage for shorting screws is supplied for each set of 3 single ratio CT's. A six point shorting type terminal block is provided for each optional multi-ratio CT.

5, 7.5 & 15KV TYPE VHK VACUUM BREAKERS

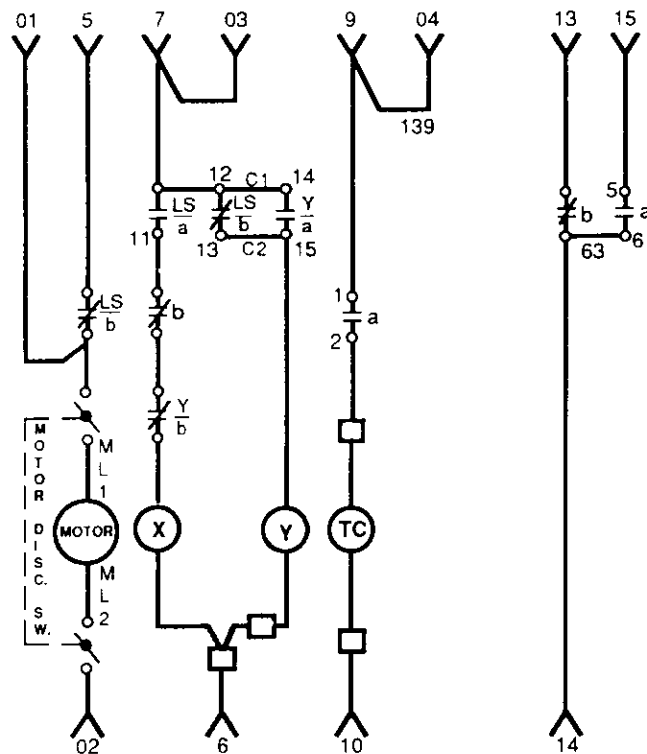

- 6 > < 5
- 9 > < 7
- 10 > < 13
- 15 > < 14
- 04 > < 03
- 02 > < 01

REAR VIEW OF SECONDARY DISCONNECTS

LEGEND

- a - Auxiliary Switch Contact Closed When Breaker is Closed.
- b - Auxiliary Switch Contact Open When Breaker is Closed.
- LSa - Limit Switch Contact Open When Springs Are Discharged. Closed When Springs Are Charged.
- LSb - Limit Switch Contact Closed When Springs Are Discharged. Open When Springs Are Charged.
- TC - Shunt Trip Coil.
- X - Closing Latch Release Coil.
- Y - Control Relay Lockout Coil.
- Ya - Normally Open Control Relay Contact.
- Yb - Normally Closed Control Relay Contact.
- ML - Motor Lead.
- C1,C2 - Terminal Jumper (Control Device).
- Female Secondary Disconnect Contact.

TYPICAL DC SCHEMATIC DIAGRAM OF CONTROL CIRCUIT

15 & 27KV TYPE GHK SF₆ BREAKERS

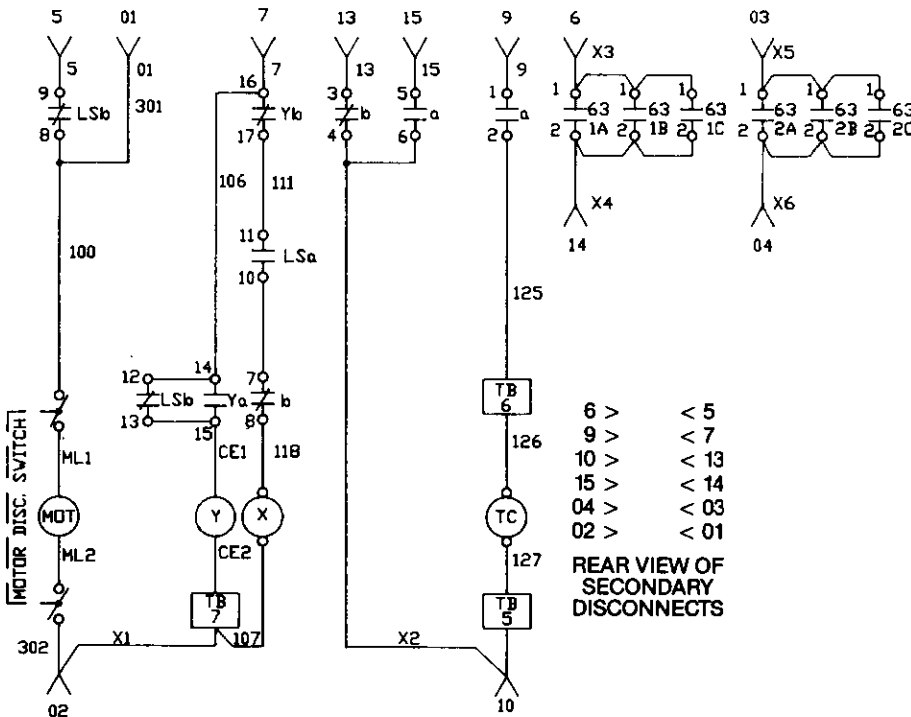

LEGEND

- a - Auxiliary Switch Contact Closed When Breaker is Closed.
- b - Auxiliary Switch Contact Open When Breaker is Closed.
- LSa - Limit Switch Contact Open When Springs Are Discharged. Closed When Springs Are Charged.
- LSb - Limit Switch Contact Closed When Springs Are Discharged. Open When Springs Are Charged.
- TC - Shunt Trip Coil.
- X - Closing Latch Release Coil.
- Y - Control Relay Lockout Coil.
- Ya - Normally Open Control Relay Contact.
- Yb - Normally Closed Control Relay Contact.
- TB - Terminal Block Point.
- ML - Motor Lead
- CE - Coil Lead End.
- C1,C2 - Terminal Jumper (Control Device).
- Female Secondary Disconnect Contact.
- 63 - Gas Pressure Switch, Contact Closed On Reduced Pressure.

- 6 > < 5
- 9 > < 7
- 10 > < 13
- 15 > < 14
- 04 > < 03
- 02 > < 01

REAR VIEW OF SECONDARY DISCONNECTS

TYPICAL DC SCHEMATIC DIAGRAM OF CONTROL CIRCUIT

- A segregated grounded metal enclosed instrument compartment for low voltage devices such as terminal blocks, pull out fuse blocks, CT shorting blocks, auxiliary relays, MOC and TOC switches.
- A hinged front door for mounting relays, instruments, indicating lights, breaker control switch, instrument transfer switches and metering.
- Front accessible fully ANSI rated relay and metering accuracy, toroidal primary bushing mounted current transformers in all ratios.
- Optional special high accuracy toroidal primary bushing mounted current transformers in all ratios.
- Optional multi-ratio standard relay accuracy toroidal primary bushing mounted current transformers in all ANSI ratios.
- Optional multi-ratio special high accuracy toroidal bushing mounted current transformers in all ANSI ratios.
- Front accessible drawout 5, 15, and 27KV fused voltage transformers connectable to incoming line, main bus or outgoing load as selected.
- Front accessible drawout 5 and 15KV primary fused control power transformer up to 15KVA single phase complete with mechanically interlocked secondary main breaker.
- Front accessible drawout 5 and 15KV primary fuses complete with mechanically interlocked secondary main breaker for separately mounted control power transformers above 15KVA up to 75KVA single phase and all three phase units up to 112.5KVA.
- Front accessible drawout 27KV primary fuses complete with mechanically interlocked secondary main breaker for separately mounted control power transformers up to a maximum of 50

KVA single phase and 150 KVA three phase.

- Optional front accessible auxiliary compartment for power company metering devices.
- Provisions for readily making future extensions in either direction.
- Hinged access panel in the circuit breaker compartment door to allow drawout racking and observation of all drawout positions and all circuit breaker indicators with the door closed.
- A segregated grounded metal enclosed main bus compartment with epoxy insulated primary main and interconnecting busses, easily removable vinyl joint covers, a standard polyester glass or optional polyester glass and porcelain combination main bus support and interframe barrier providing a fully coordinated insulation system.
- A standard bolted metal panel or optional hinged metal door provides rear access to a segregated grounded metal enclosed incoming or outgoing primary cable, transformer bus or bus duct termination compartment.
- Rear accessible designated space to permit mounting of optional lightning arresters, surge suppressors, potheads, cable terminators, stress cones, ground fault sensor, or primary cable supports. In Two-High construction a combination primary cable raceway and barrier provides isolation for primary cables passing through to an adjacent compartment. In the case of Tie breaker, a segregated grounded metal enclosed transition bus may also traverse the area

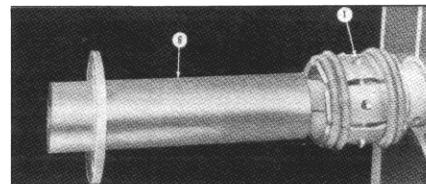

Primary Disconnects — The self aligning Power Circuit Breaker mounted Primary Female Disconnects (1) use conservatively designed lock-wound stainless steel multiple springs to assure the proper high pressure contact with the stationary primary male disconnects (6) mounted in the switchgear. Primary disconnects are mated only in the drawout connected position.

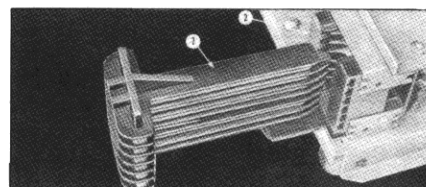

Secondary Disconnects — The self aligning Power Circuit Breaker mounted Female Secondary Disconnects (2) automatically mate with the switchgear male contacts (1) when in drawout test and connected positions. These secondary disconnects automatically disengage when the drawout element is racked to disconnected position.

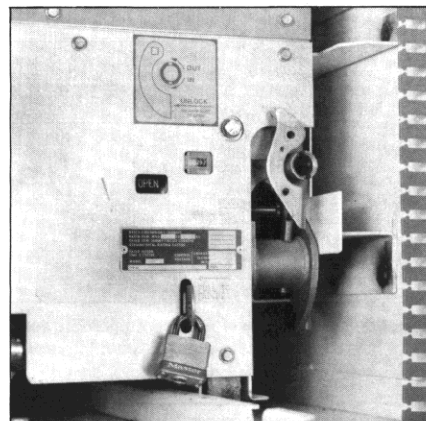

Padlocking — The power circuit breaker comes standard with a padlock hasp that will accommodate up to three padlocks. When the padlocking hasp is pulled out and a padlock is in place, the power circuit breaker is locked open in two drawout positions (test, disconnected). Padlocking prevents closing and racking until all padlocks are removed. Padlocking provisions in the connected position is optional.

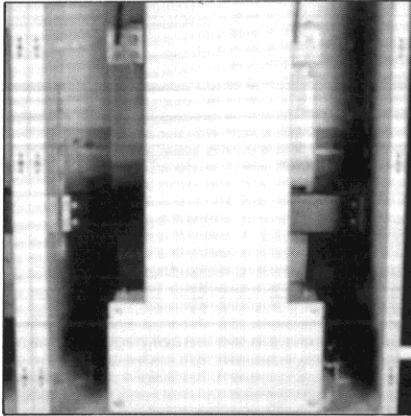

Rear Power Cable Compartments — In a frame with two power circuit breakers a steel raceway is provided for isolating the set of power cables that must pass through one rear power cable compartment en route to another. This raceway is easily removed during installation to facilitate cable pulling and terminating. Since this raceway is symmetrical it may be readily field reinstalled in either the upper or lower power cable compartments, as required, with the power cables installed. Optional cable supports are available.



Closed-door Safety — An integrally mounted hinged access panel is incorporated into the power circuit breaker compartment door to enable racking the Power Circuit Breaker between connected, test and disconnected drawout positions with the compartment door securely closed. Accordingly, in addition to the power circuit breakers own grounded steel front barrier, a second grounded steel barrier is provided for further operator safety during the racking process. Mechanical interlocks prevent racking unless the power circuit breaker has been tripped and its primary contacts are in the fully open position unblocking the racking release lever. Positive stops of the racking screw automatically select connected, test or disconnected captive drawout positions all with the compartment door closed. The risk of cluttered aisles and the entry of foreign materials from open compartment doors is eliminated.



Hinged Panel — An instruction label on the exterior of the hinged panel clearly describes the operation of the racking release lever and the racking screw. These essential features are readily accessible regardless of power circuit breaker drawout position.

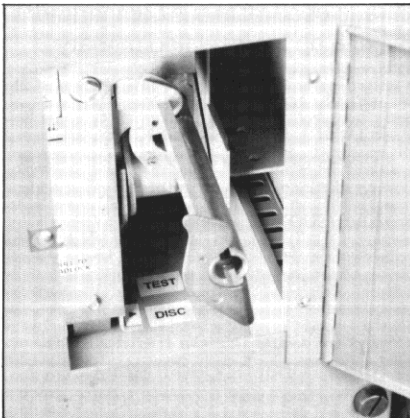

Drawout Position Indicator — A drawout position indicator on the power circuit breaker points to an indicator on the floor making the drawout position of the power circuit breaker clearly visible without the necessity of opening the circuit breaker compartment door.

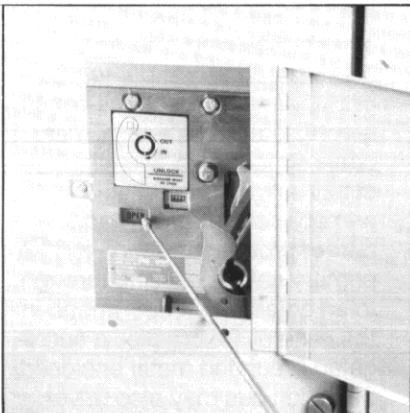

Open-closed Indicator — The power circuit breaker open-closed indicator and operation counter can easily be observed through the hinged access panel.

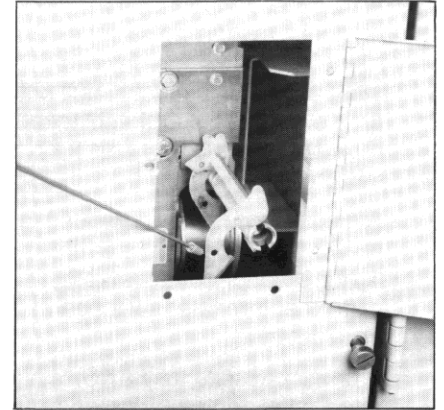

Racking Release Lever — With the power circuit breaker tripped open rotate this lever clockwise to release the racking screw and permit its rotation by the racking crank. The racking release lever provides automatic stop and latch in connected, test and disconnected drawout positions. The power circuit breaker operating mechanism is held trip free in between drawout positions and in the withdraw position.

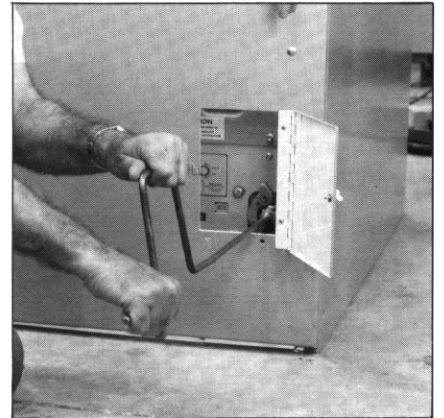

Closed Door Racking — After releasing the racking screw and with the racking crank engaged rotate the racking screw clockwise for inward and counter-clockwise for outward movement of the power circuit breaker. When racking from disconnected to withdraw the stored energy springs are automatically discharged and the power circuit breaker remains open.

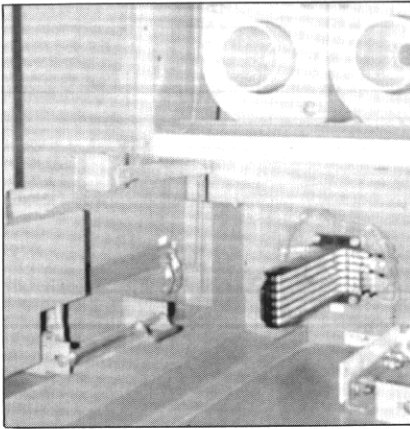

Safety Shutter Actuator — An actuator on the power circuit breaker engages the safety shutter operating linkage causing it to open as the power circuit breaker is racked from test to connected drawout position. Stored spring energy provides for the closing of the safety shutter when the power circuit breaker is out of the connected position. As an additional safeguard whenever the circuit breaker is withdrawn its shutter actuator cams the safety shutter closed.

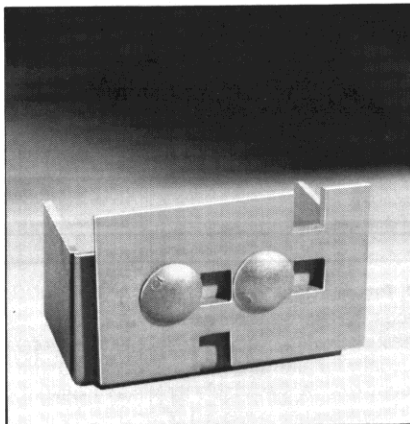

Interference Block — The interference block permits correctly rated drawout elements to be inserted and rejects insertion of incorrectly rated devices.

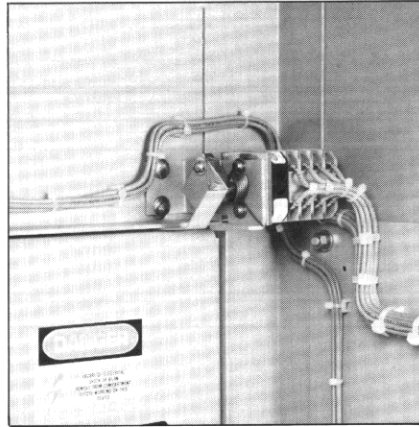

Truck Operated Cell (TOC) Switch — An optional eight contact TOC switch changes position as the power circuit breaker is racked from test to connected or from connected to test drawout positions. Normally open (a) and normally closed (b) contacts are equally divided.

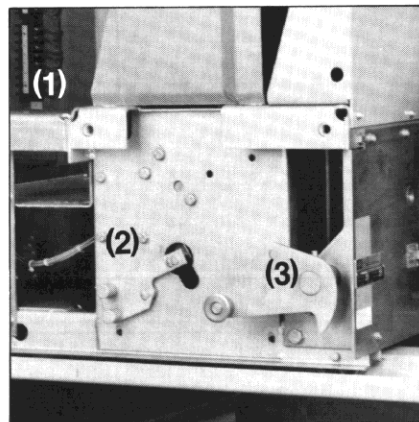

Power Circuit Breaker Coordinated Interfaces —

1. Shutter actuator engages the switchgear shutter mechanism to open or close the safety shutter.
2. The circuit breaker mechanism actuator interfaces with the switchgear MOC switch actuator treadle.
3. The circuit breaker racking cam mates with the switchgear mounted racking slots to change drawout position of the circuit breaker during the racking process.

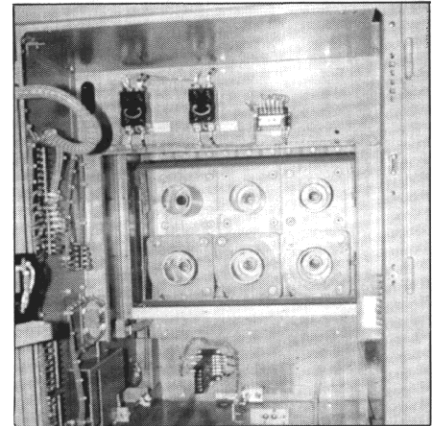

Dual Guide Rails — Floor mounted full length dual guide rails assure positive alignment of the drawout element within the power circuit breaker compartment to achieve the proper mating of all primary, secondary, and grounding contacts.

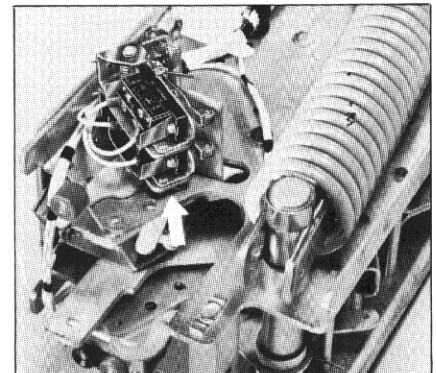

Latch Check Switch — The optional latch check switch prevents closing unless the trip latch is properly reset.

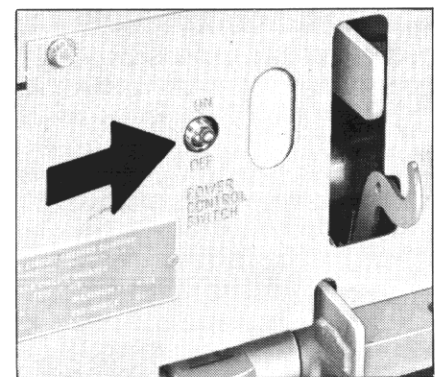

Charging Motor Disconnect Switch — A two position on/off switch provides a simple means of disconnecting control power to the charging motor whenever desired.

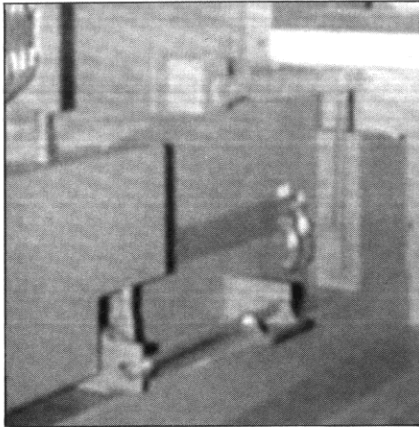

MOC Switch Actuator Treadle — The standard MOC switch actuator treadle engages the power circuit breakers operating mechanism actuator while in the connected drawout position only to change position with the opening and closing of the power circuit breaker. An optional treadle is available to engage in both the test and connected positions.

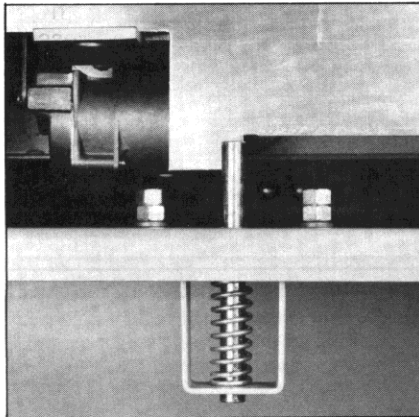

Circuit Breaker Compartments — Integral wheels on the drawout elements coupled with floor mounted guide rails readily enable insertion into or removal from the lower compartment without the need of a lifting device. In addition to the standard four drawout positions a safety blocking device prevents the drawout element from inadvertently rolling out of upper compartment. (See photo above.) When the lifting device is properly engaged and automatically secured in place the blocking feature is defeated to permit safely rolling the drawout element onto the lifting platform.

The safety shutter assembly provides an effective barrier to all primary voltages whenever the drawout element is not in the connected position.

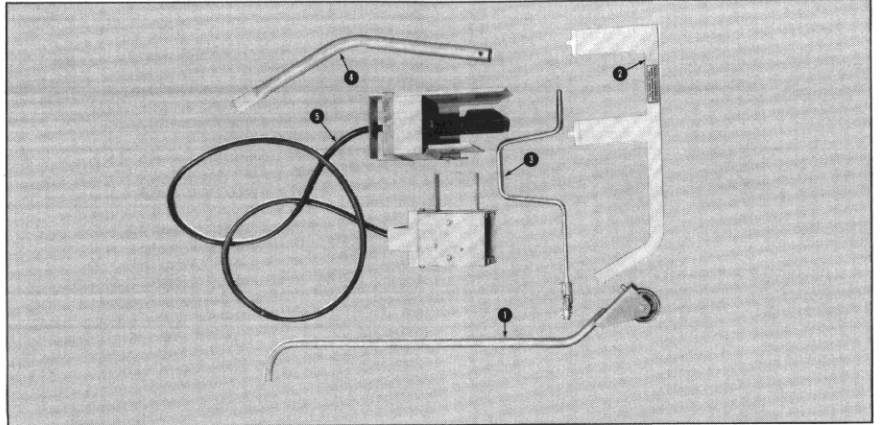

Typical Standard Accessories

1. Fifth wheel
2. Slow close bracket (SF₆ only)
3. Racking crank
4. Manual charging handle
5. Test jack and plug
6. Lifting yoke (not shown)

Typical Optional Accessories (not shown)

- Breaker lifting device
- Ground and test devices
- Remote control racking device
- Test cabinet
- Vacuum breaker high potential test device
- Breaker dolly

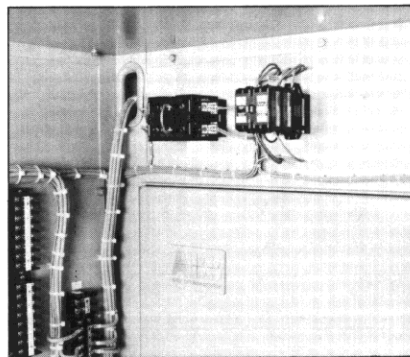

Personnel Safety — With the power circuit breaker in the connected drawout position its grounded front barrier assembly mates with a stationary collar in the switchgear to form a protective shield from primary voltages in the circuit breaker compartment.

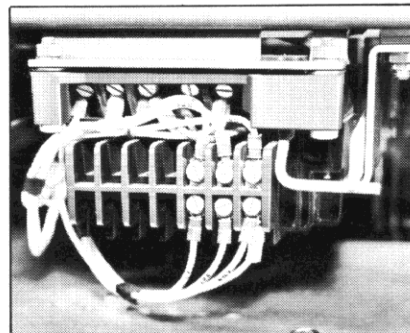

Control Relay — The control relay incorporates the "X" and "Y" coils together with the mechanical interlocking linkage to assure anti-pump when closing into a fault. Limit switches prevent closing until the stored energy springs are fully charged to assure uniform closing force.

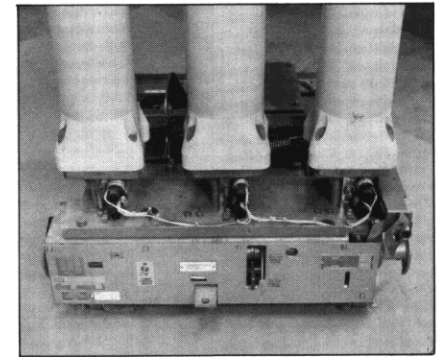

SF₆ Pressure Switches — All GHK Power Circuit Breakers are provided with two SF₆ Pressure Switches on each pole. One switch is usually for alarming low pressure while the second switch is available for trip and lockout or lock closed as preferred when the pressure drops below predetermined levels.

The finest quality insulating materials are used throughout ABB Metal-Clad Switchgear to assure a well coordinated insulation system. Each type of insulation material — polyester glass, epoxy or ceramics — is selected for its own specific characteristics to satisfy the application requirements before it is integrated into the overall insulation system.

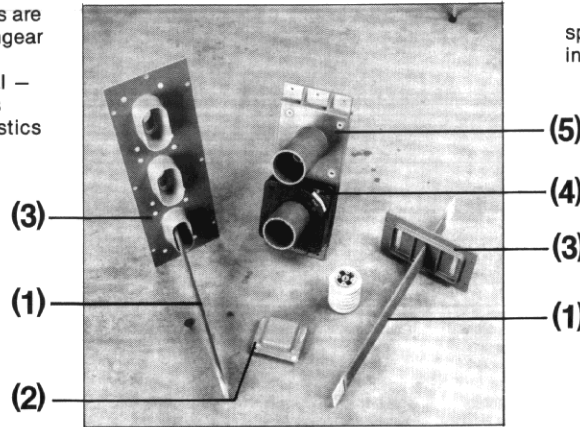

Unequaled dielectric performance from specially developed insulation materials incorporate these latest improvements.

(5) Low Moisture Absorption
High Impulse Strength

(4) Flame Retardance
Track Resistance

(3) Corona Freedom
Low Power Factor

SWITCHGEAR INSULATION

(1) Bus

All bus, including bends and odd configurations, is fully insulated with an epoxy compound.

(2) Bus Joints

All bus joints, taps, and splices are covered with a low power factor, air filled vinyl boot secured in place with nylon hardware making these connections accessible with minimum effort.

(3) Bus Supports

All insulated bus risers to incoming or outgoing connections are supported by wet process porcelain or equivalent for all voltages except 5KV. For 5KV, polyester-glass bus supports are used. 1200A and 2000A insulated main and tie transition bus penetrating metal barriers is supported by pre-form molded polyester-glass through bushings imbedded into polyester glass SMC as standard. Porcelain through bushings imbedded into polyester-glass SMC is optional. 3000A insulated main and tie transition bus penetrating metal barriers is supported by porcelain bushings imbedded into polyester-glass SMC as standard. For 27KV porcelain bus supports are standard for all bus ratings.

(4) Current Transformers

Standard C.T.'s rated at 2500:5A and below are enclosed by a Noryl molded case. For all other C.T.'s a rigid epoxy case is cast and the C.T. winding is placed into the case and potted with a flexible polyurethane resin.

(5) Primary Disconnects

Pre-form molded polyester-glass bushing assemblies house the 1200A and 2000A, 5, 7.5 and 15KV primary disconnects as standard. Porcelain bushing assemblies imbedded in pre-form molded polyester-glass is optional for 1200A and 2000A and standard for 3000A ratings. For 27KV, cast epoxy duresca bushings imbedded in pre-form molded polyester-glass house the primary disconnects for all current ratings.

Safety Shutters

The moving portion of the safety shutter covering the primary disconnects is painted steel for all ratings, except for the one high 5KV-250MVA which is made of insulating material.

Circuit Breaker Insulation

Primary Lead Supports

Primary lead supports for vacuum circuit breakers are polyester-glass SMC moldings for 1200A and 2000A ratings. For 3000A ratings polyester-glass laminates are used. Molded epoxy glass housings are used for SF₆ gas interrupters. Push rods are molded epoxy glass or polyester-glass and polyurethane.

Interphase Barriers

Interphase barriers for 3000A vacuum circuit breakers are pre-form polycarbonate sheets. For 1200A and 2000A vacuum breakers the primary lead supports provide the required interphase barriers. The totally insulated housings of SF₆ interrupters eliminate the need for additional interphase insulation except at 27KV where primary leads are covered with a plastisol boot, lexan, polyester-glass and epoxy parts are utilized as spacers and stabilizers.

**TYPICAL ARRANGEMENTS, TWO-HIGH CONSTRUCTION
5KV-350, 7.5KV-500 AND 15KV-500, 750 OR 1000MVA**

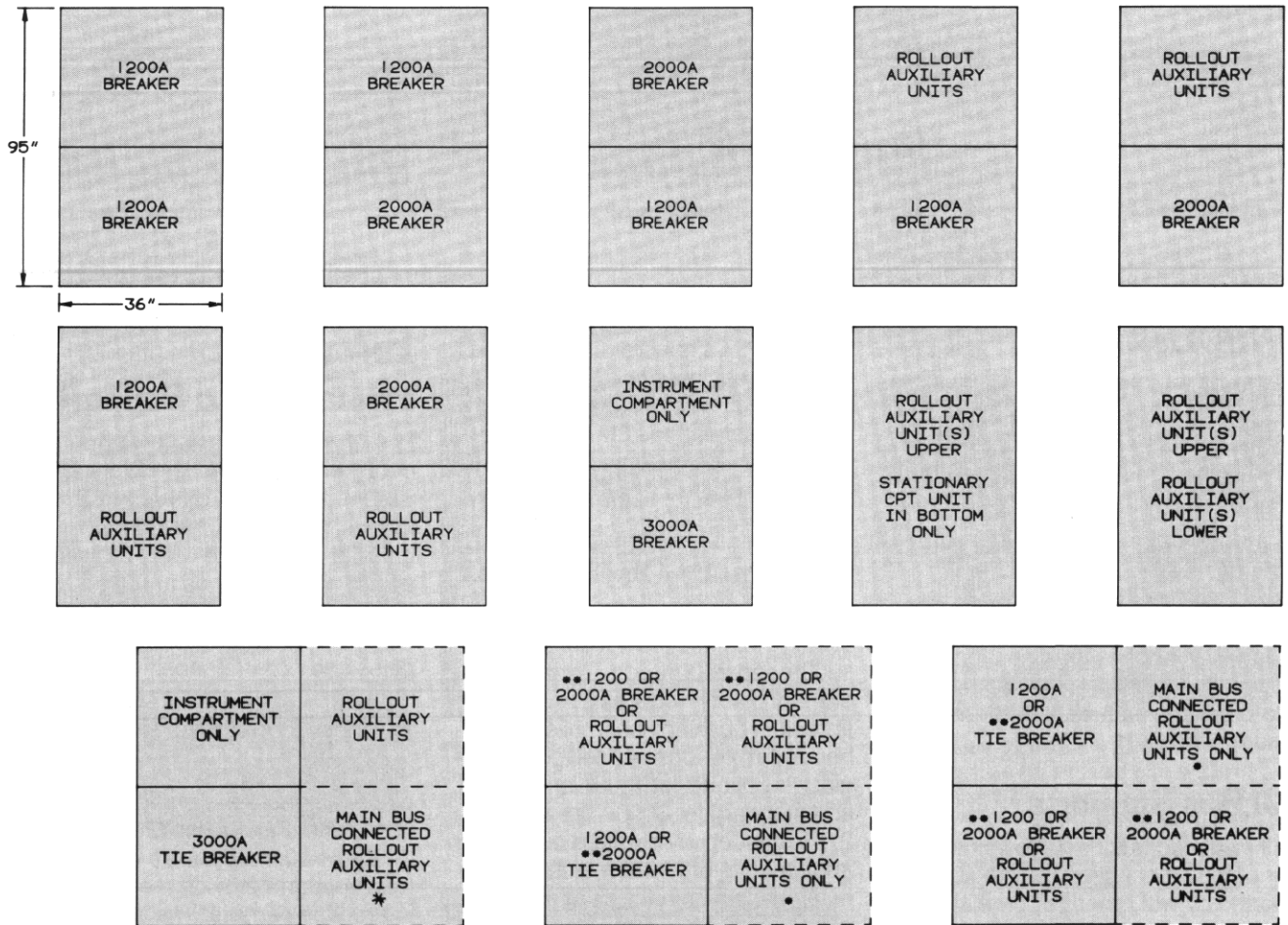

* AUXILIARY COMPARTMENT REQUIRED ADJACENT TO TIE BREAKER. •• ONLY ONE 2000A BREAKER IN ANY VERTICAL FRAME

NOTES: The following material can be mounted in 22.5 inch high drawout units:

- One, two or three primary fused PT units
- Single phase 15KVA CPT with its primary fuses and secondary 2-pole breaker
- Single pole switched primary fuse unit with kirk key interlock for stationary mounted single phase CPT connected phase to ground and rated 37.5 through 75KVA

For CPT applications different from the above, contact nearest ABB sales representative for further information.

**TYPICAL SECTION VIEWS – TWO HIGH CONSTRUCTION
5KV-350, 7.5KV-500, 15KV-500, 750 OR 1000MVA**

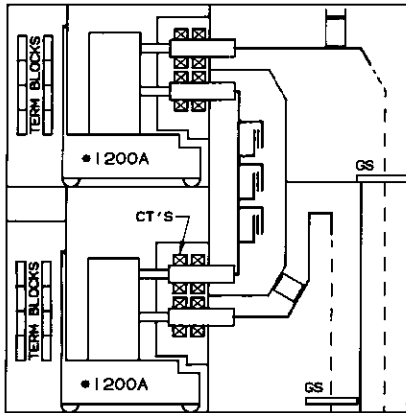

BREAKER/BREAKER (BOTTOM ENTRY)

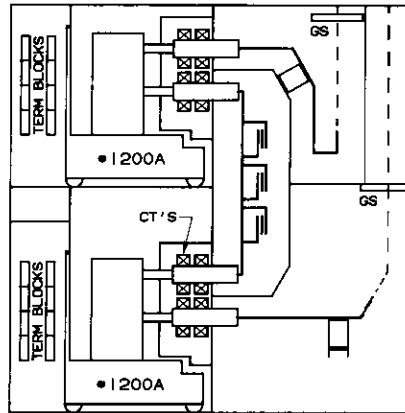

BREAKER/BREAKER (TOP ENTRY)

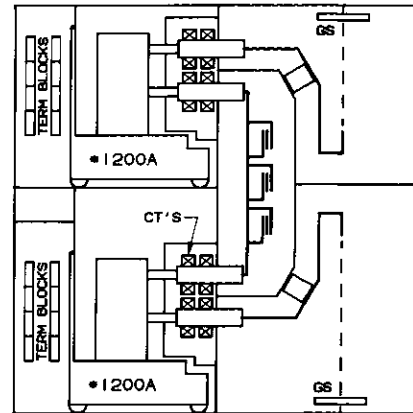

BREAKER/BREAKER (TOP AND BOTTOM ENTRY)

*A 2000A BREAKER CAN BE SUBSTITUTED FOR ONE 1200A IN ANY FRAME

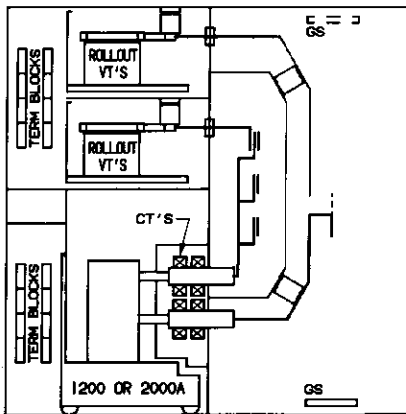

AUXILIARY/BREAKER (TOP OR BOTTOM ENTRY)

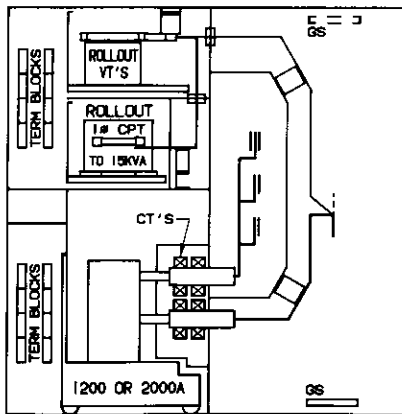

AUXILIARY/BREAKER (TOP OR BOTTOM ENTRY)

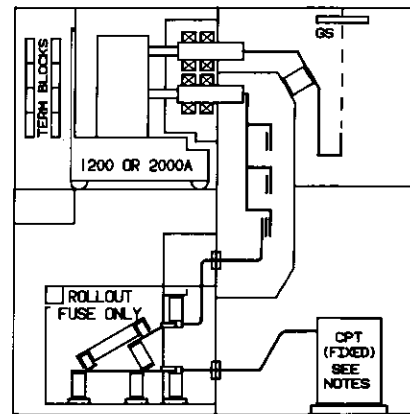

BREAKER/AUXILIARY (TOP ENTRY)

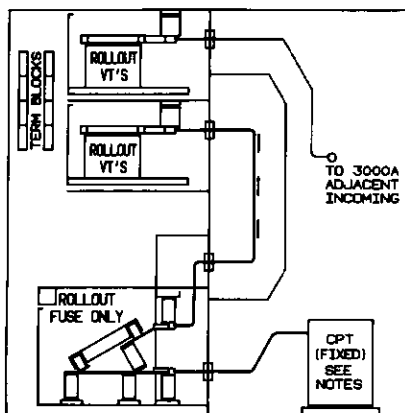

AUXILIARY/AUXILIARY

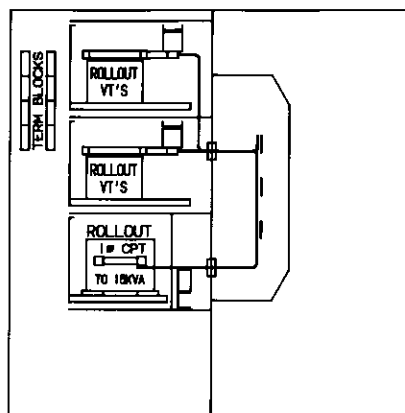

AUXILIARY/AUXILIARY

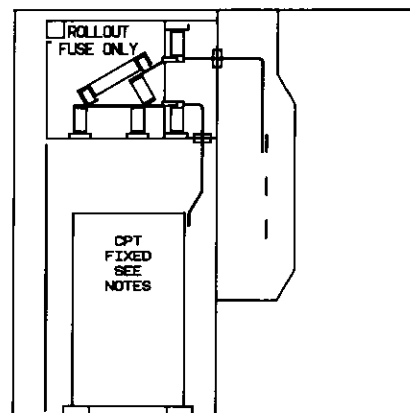

AUXILIARY/AUXILIARY

**TYPICAL SECTION VIEWS – TWO HIGH CONSTRUCTION
5KV-350, 7.5KV-500 AND 15KV-500, 750 AND 1000MVA**

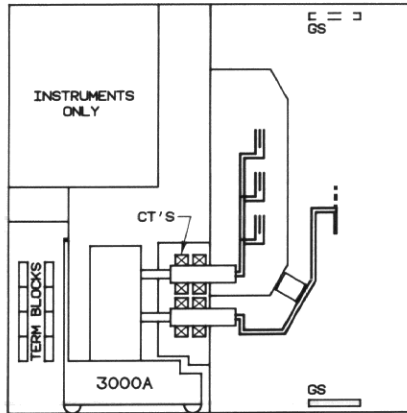

INSTRUMENT/BREAKER (TOP OR BOTTOM ENTRY)

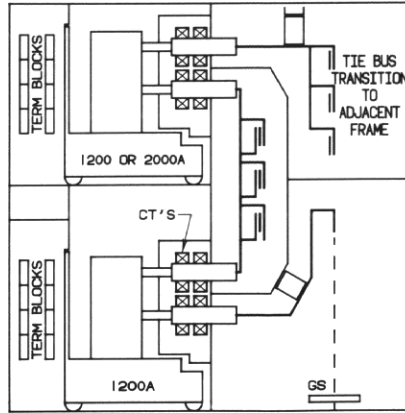

BREAKER/BREAKER (TOP TIE) (BOTTOM ENTRY)
(CAN ALSO BE SUITED FOR TOP ENTRY)

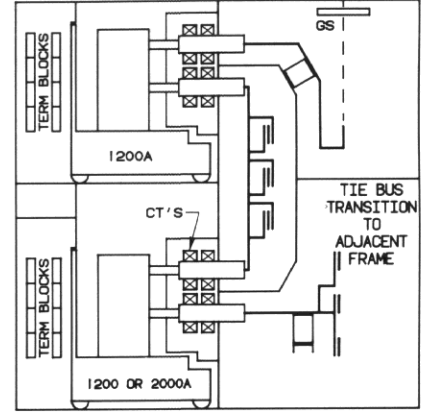

BREAKER/BREAKER (BOTTOM TIE) (TOP ENTRY)
(CAN ALSO BE SUITED FOR BOTTOM ENTRY)

**TYPICAL ARRANGEMENTS – TWO HIGH CONSTRUCTION
27KV-500, 750 AND 1000MVA**

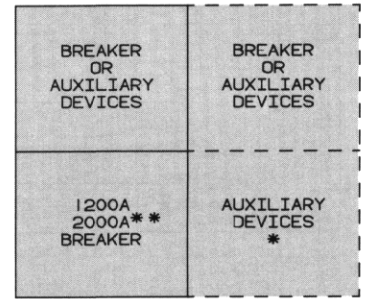
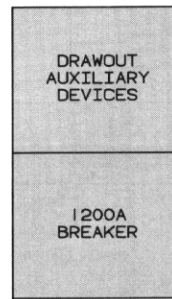
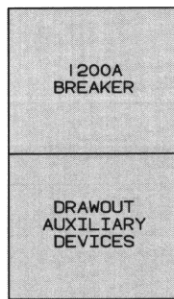
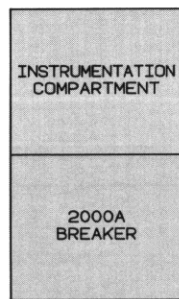
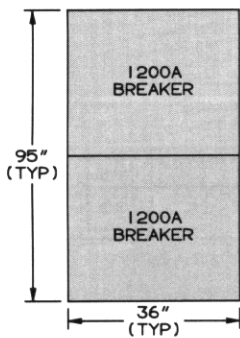

* AUXILIARY COMPARTMENT REQUIRED ADJACENT TO TIE BREAKER.

** NO BREAKER OR AUXILIARY DEVICES CAN BE PLACED ABOVE A 2000A BREAKER.

NOTE: Potential transformers and CPT fuses are truck mounted and require a full 45 inch high auxiliary compartment.

TYPICAL SECTION VIEWS – TWO HIGH CONSTRUCTION 27KV-500, 750 AND 1000MVA

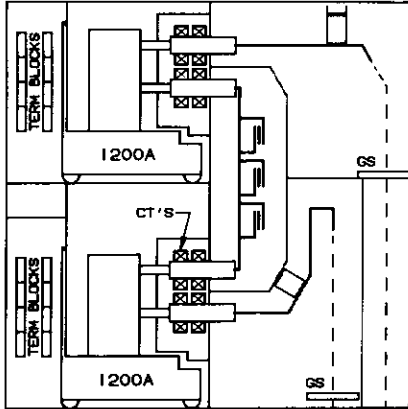

BREAKER/BREAKER (BOTTOM ENTRY)

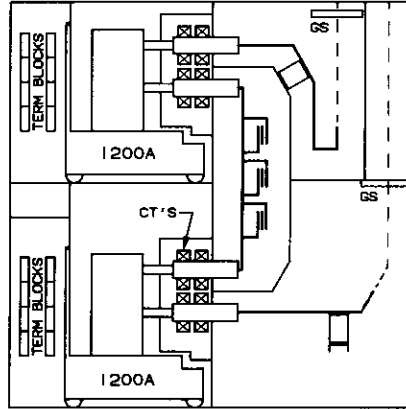

BREAKER/BREAKER (TOP ENTRY)

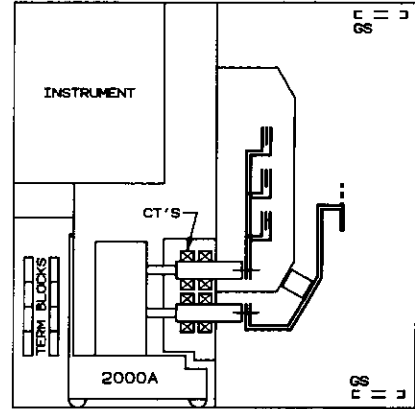

INSTRUMENT/BREAKER (TOP OR BOTTOM ENTRY)

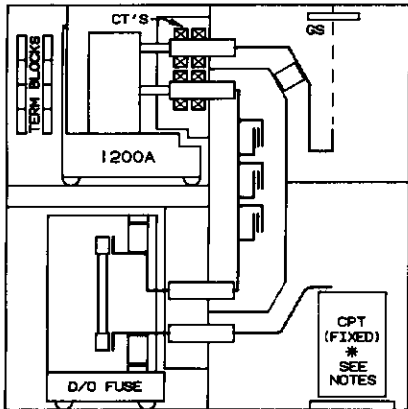

BREAKER/AUXILIARY (TOP ENTRY)

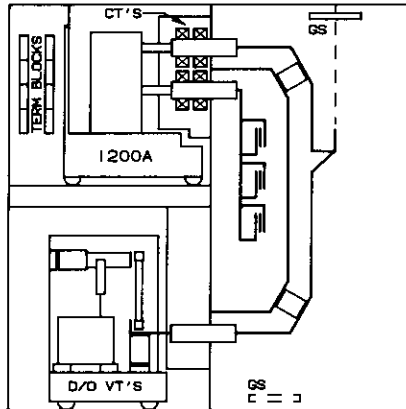

BREAKER/AUXILIARY (TOP OR BOTTOM ENTRY)



AUXILIARY/BREAKER (TOP OR BOTTOM ENTRY)

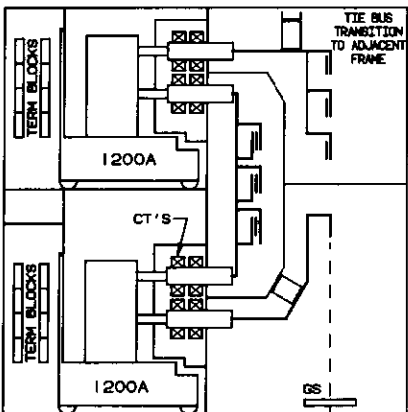

BREAKER/BREAKER (TOP TIE) (BOTTOM ENTRY)

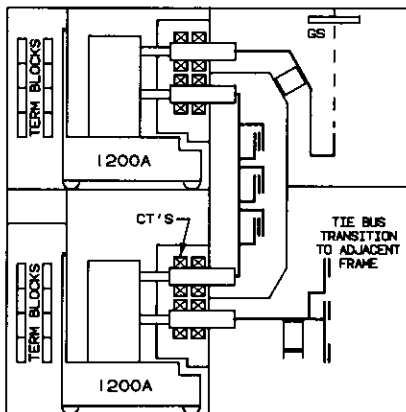

BREAKER/BREAKER (BOTTOM TIE) (TOP ENTRY)

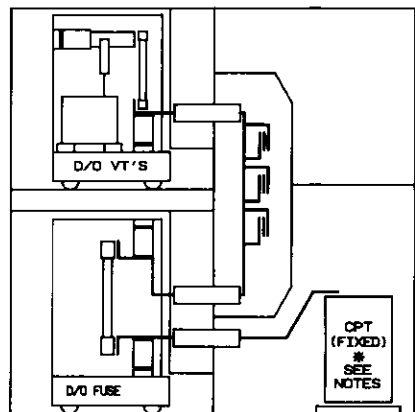

AUXILIARY/AUXILIARY

**TYPICAL FLOOR PLAN – TWO HIGH CONSTRUCTION
5KV-350, 7.5KV-500, 15KV-500, 750, 1000, 27KV-500, 750 AND 1000MVA**

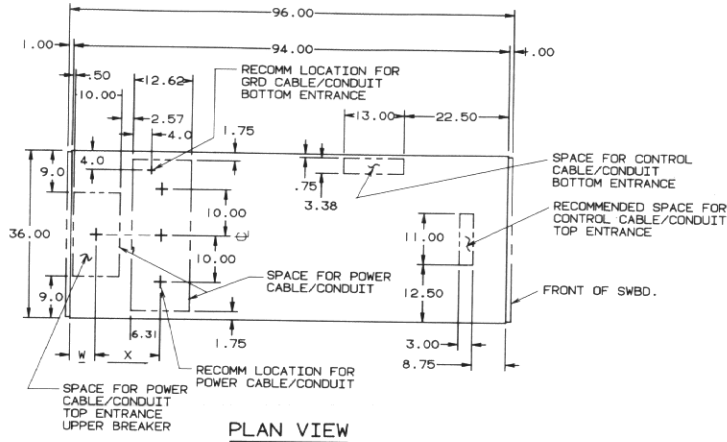

aisle space — front

RECOMMENDED: 76"
MINIMUM: 68"

aisle space — rear

RECOMMENDED: 38"
MINIMUM: 30"

BREAKER TYPE	W	X
1200 & 2000A. FEEDER	5.5	19.38
1200A.TIE & TRANSIT	5.5	--
2000A.	--	19.38
3000A.	--	17.38

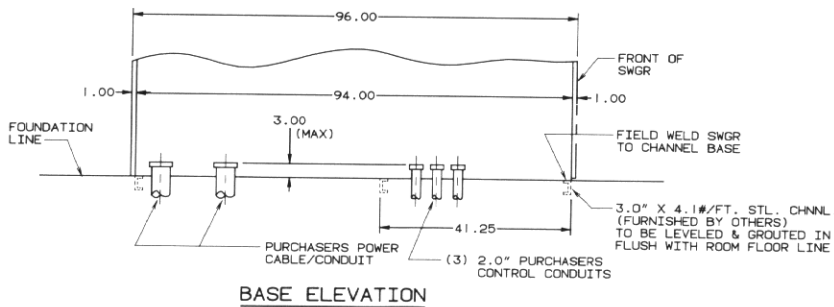

**TYPICAL ARRANGEMENTS, ONE HIGH CONSTRUCTION
5KV-350, 7.5KV-500 AND 15KV-500, 750 OR 1000MVA**

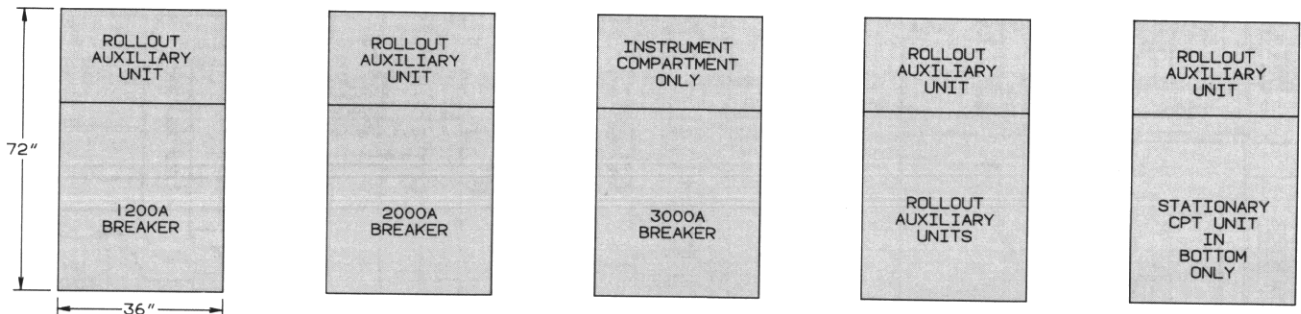

- NOTE:
1. SEE NOTES UNDER SAME RATINGS FOR TWO HIGH CONSTRUCTION
 2. AVAILABLE MOUNTING HEIGHT ABOVE BREAKER, 24.5.
 3. AVAILABLE MOUNTING HEIGHT IN LOWER SECTION, 47.5".
 4. WHEN ROLLOUT AUX. UNIT IN UPPER COMPARTMENT IS CONNECTED TO BUS RISER A 4"x4" OVERHEAD WIREWAY IS REQUIRED.

**TYPICAL SECTION VIEWS – ONE HIGH CONSTRUCTION
5KV-350, 7.5KV-500; 15KV-500, 750 AND 1000MVA**

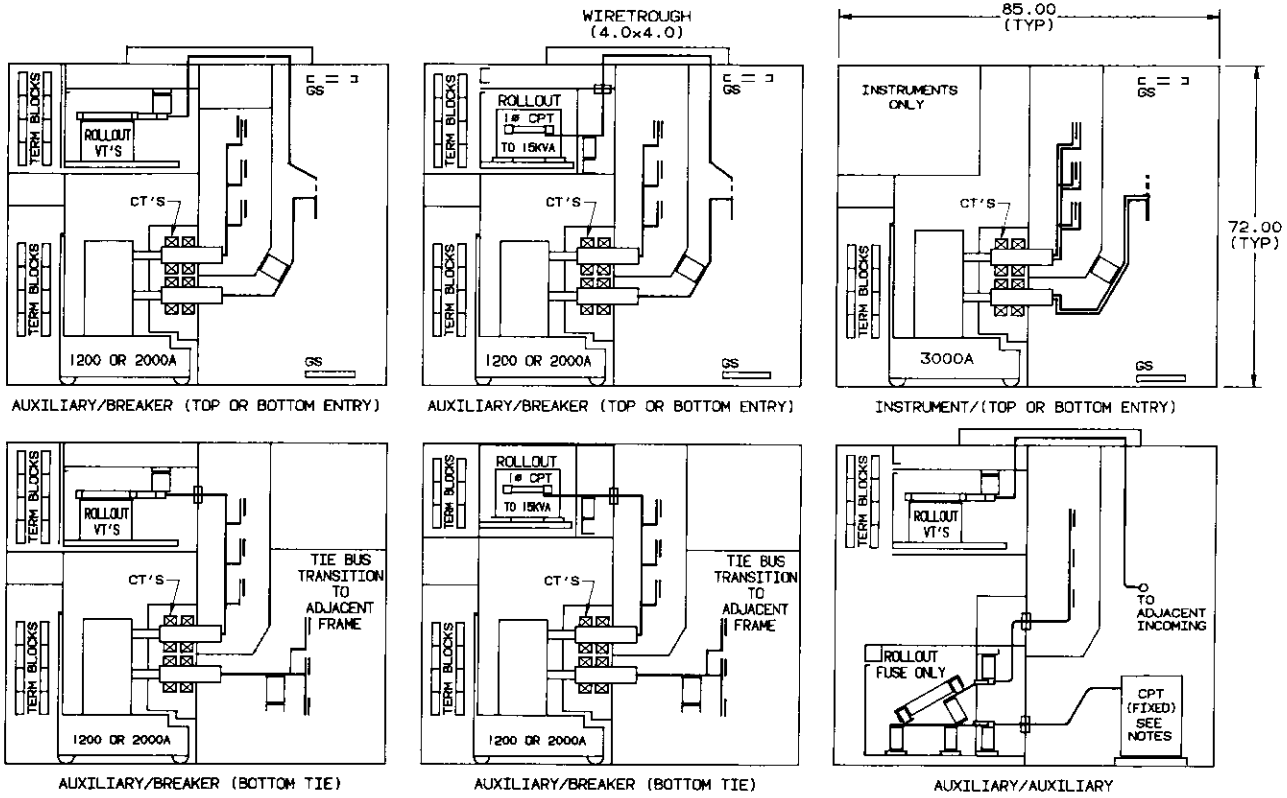

**TYPICAL FLOOR PLAN – ONE HIGH CONSTRUCTION
5KV-350, 7.5KV-500 AND 15KV-500, 750, 1000MVA**

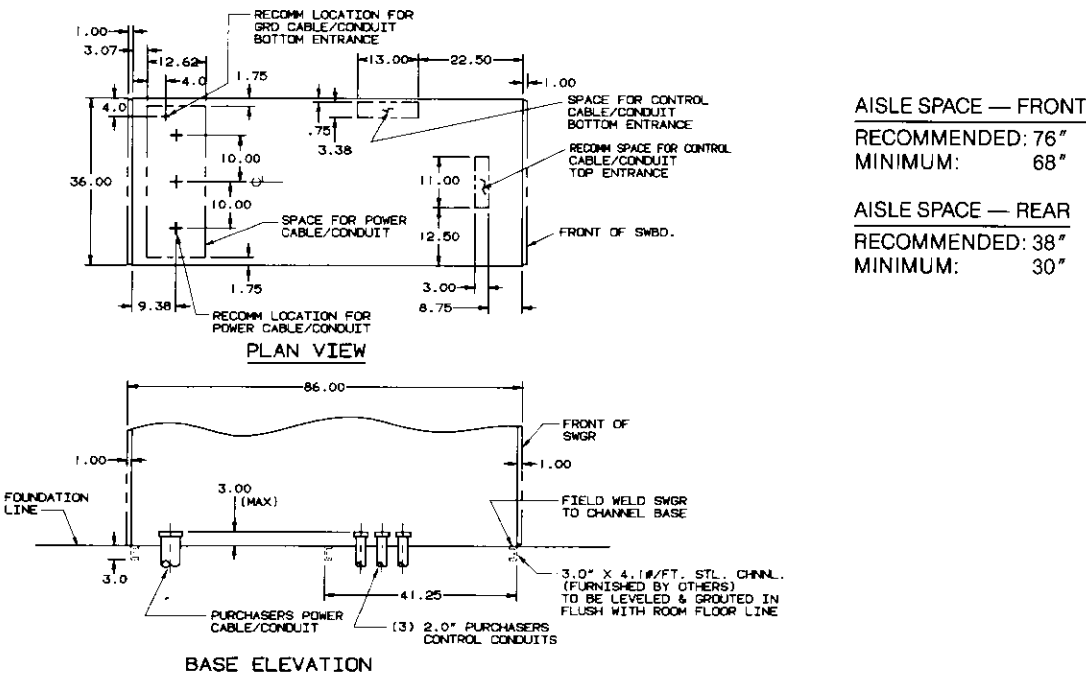

**TYPICAL OUTDOOR NON WALK-IN SWITCHGEAR
TWO-HIGH CONSTRUCTION
5KV-350, 7.5KV-500, 15KV-500, 750, 1000, 27KV-500, 750 & 1000MVA**

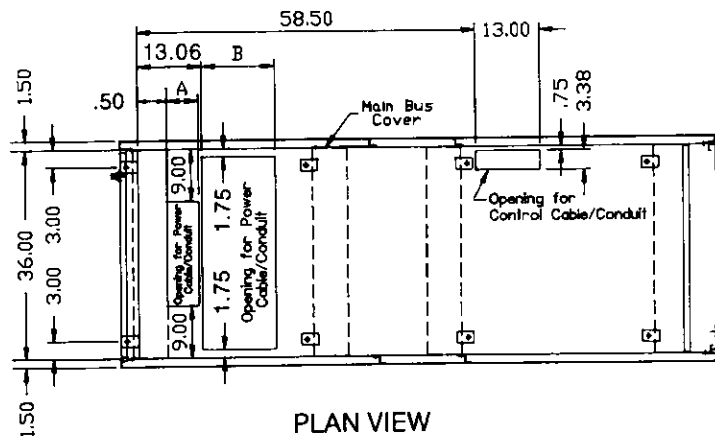
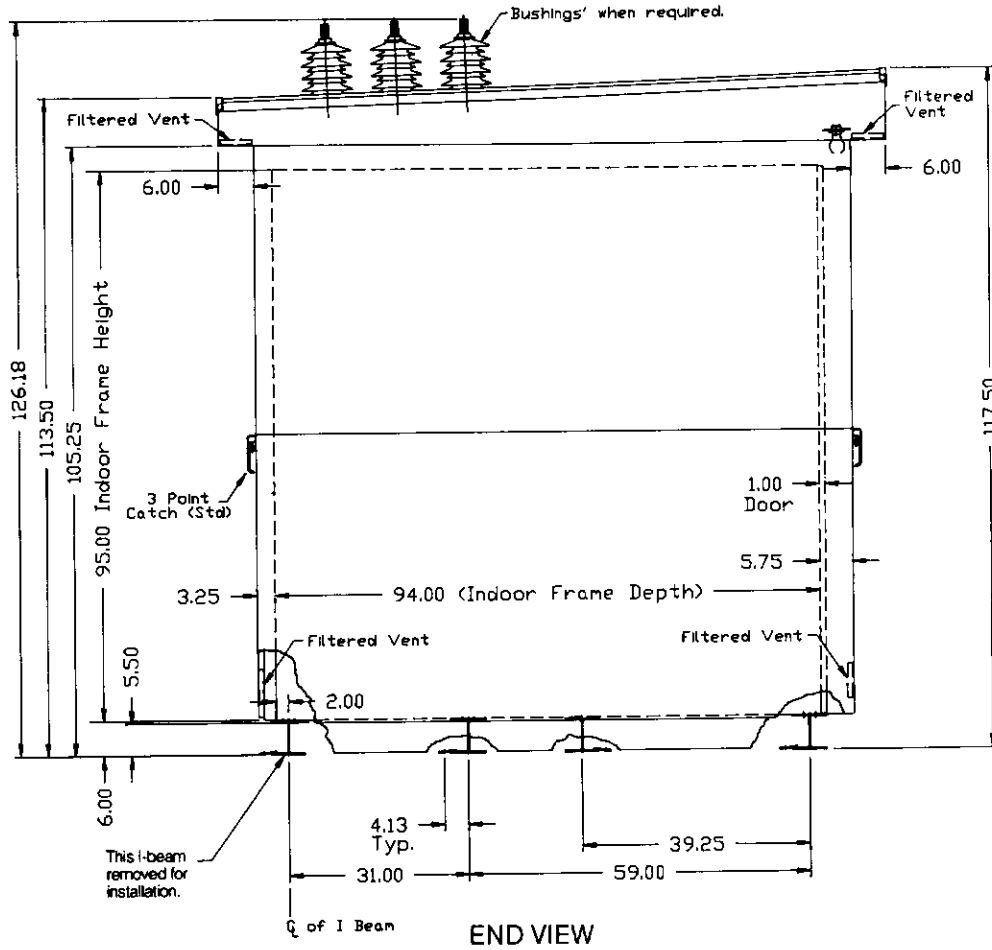

FOR 1200 & 2000A DIM. A = 5.00 & B = 12.62
FOR 3000A DIM. A = OMIT & B = 16.62

**TYPICAL OUTDOOR SINGLE ROW WALK-IN SWITCHGEAR
TWO-HIGH CONSTRUCTION**
5KV-350, 7.5KV-500, 15KV-500, 750, 1000, 27KV-500, 750 & 1000MVA

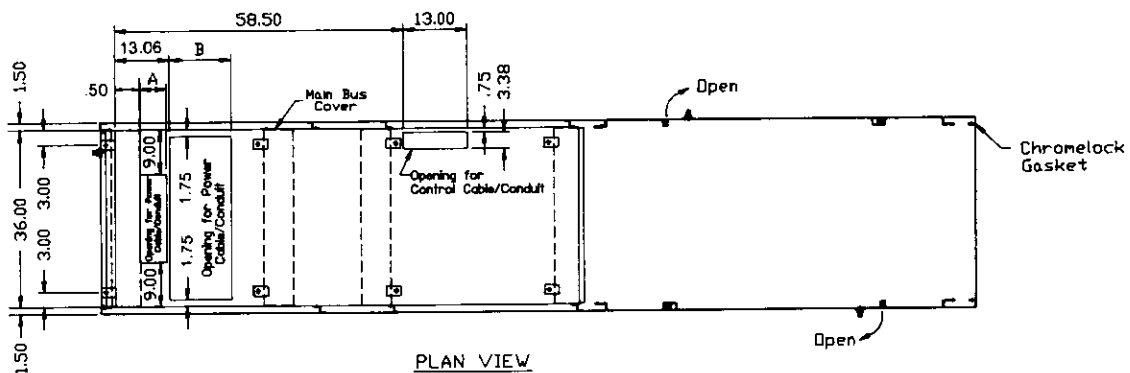
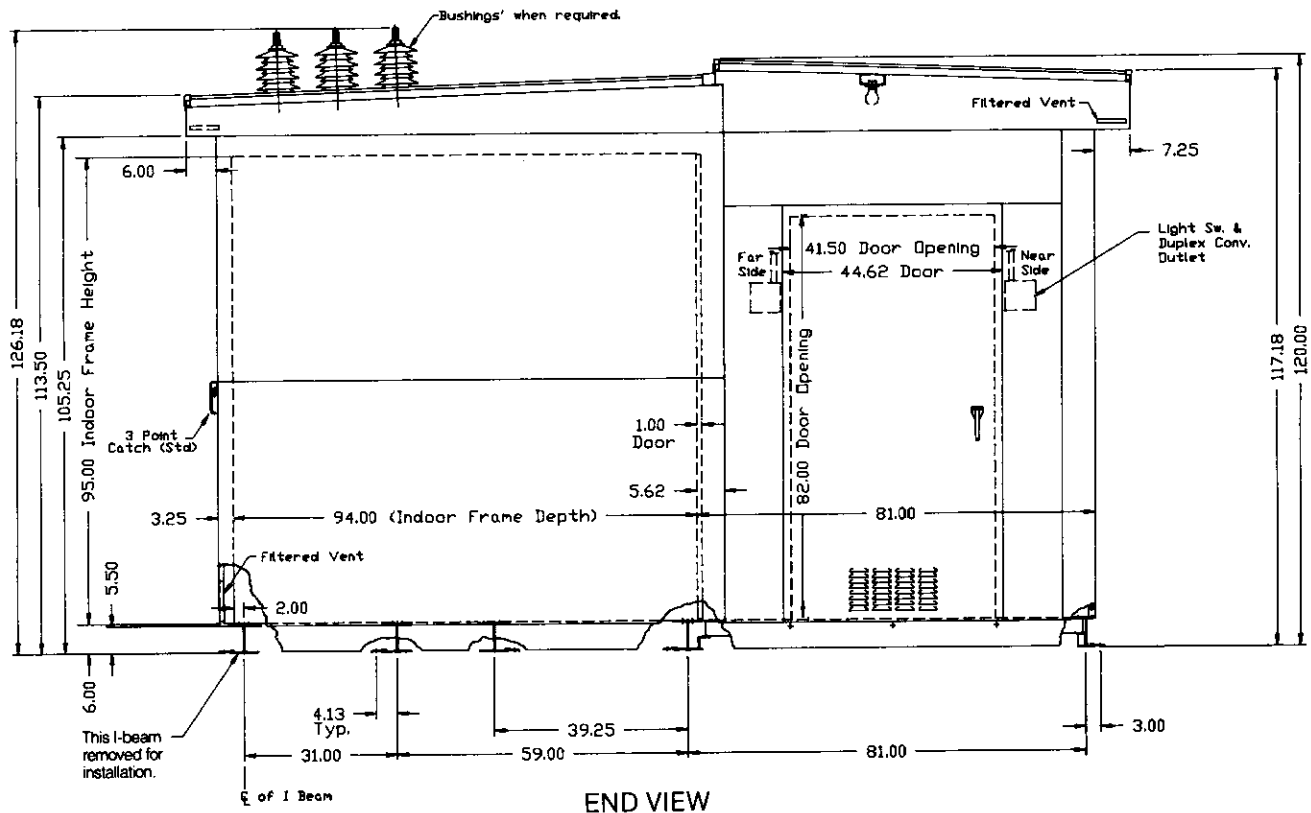

FOR 1200 & 2000A DIM. A = 5.00 & B = 12.62
FOR 3000A DIM. A = OMIT & B = 16.62

**TYPICAL OUTDOOR DOUBLE ROW WALK-IN SWITCHGEAR
TWO-HIGH CONSTRUCTION
5KV-350, 7.5KV-500, 15KV-500, 750, 1000, 27KV-500, 750 & 1000MVA**

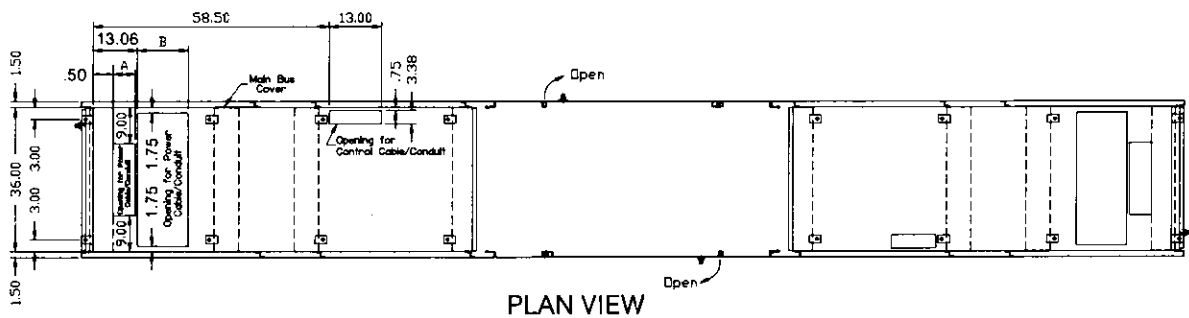
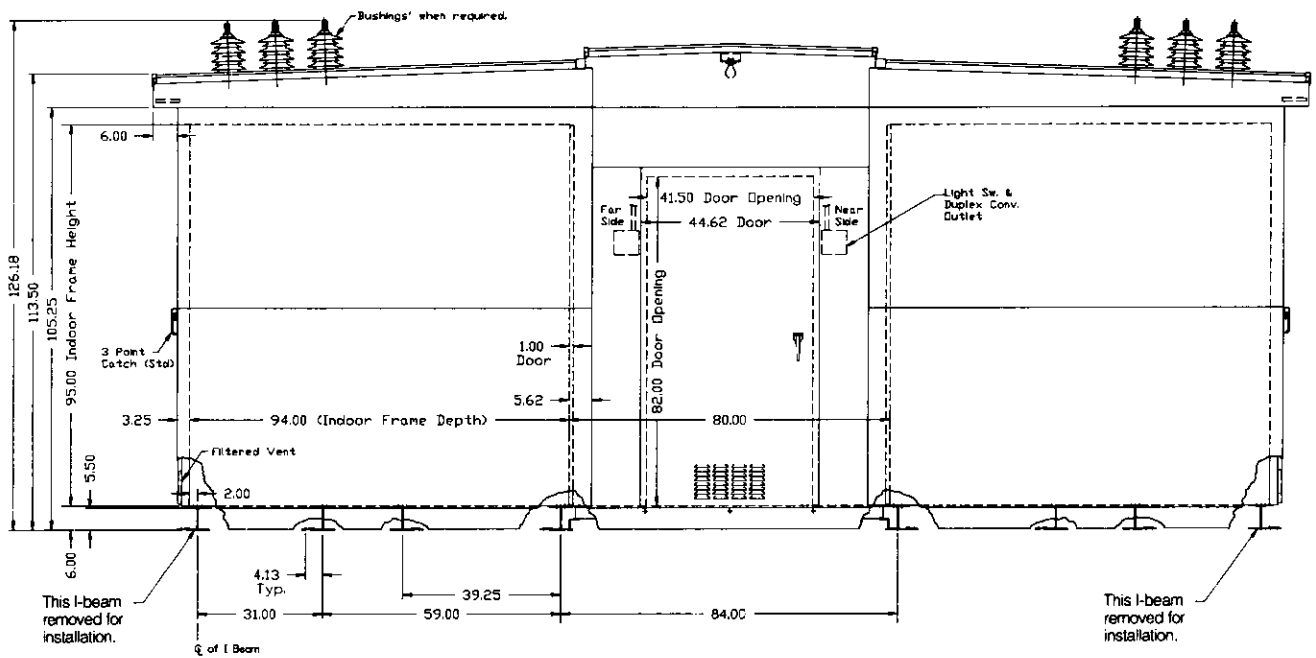

FOR 1200 & 2000A DIM. A = 5.00 & B = 12.62
FOR 3000A DIM. A = OMIT & B = 16.62

TYPICAL ARRANGEMENTS – ONE HIGH CONSTRUCTION 5KV-250MVA

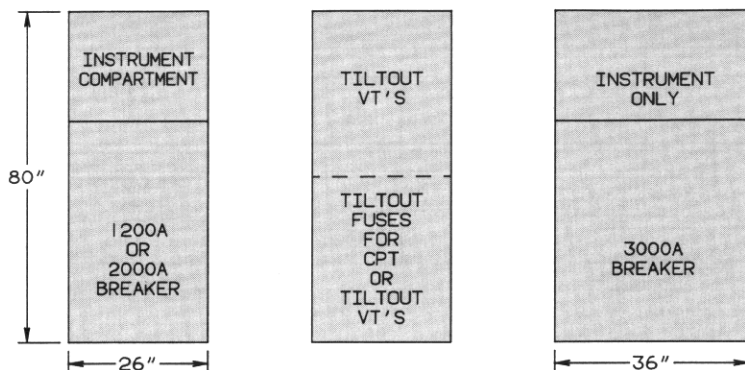

NOTE: WITH 3000A BREAKER FRAME IN LINE-UP A DEPTH OF 78" IS REQUIRED. USING A 12" FRONT EXTENSION FOR 26" WIDE FEEDER FRAMES.

TYPICAL SECTION VIEWS – ONE HIGH CONSTRUCTION 5KV-250MVA

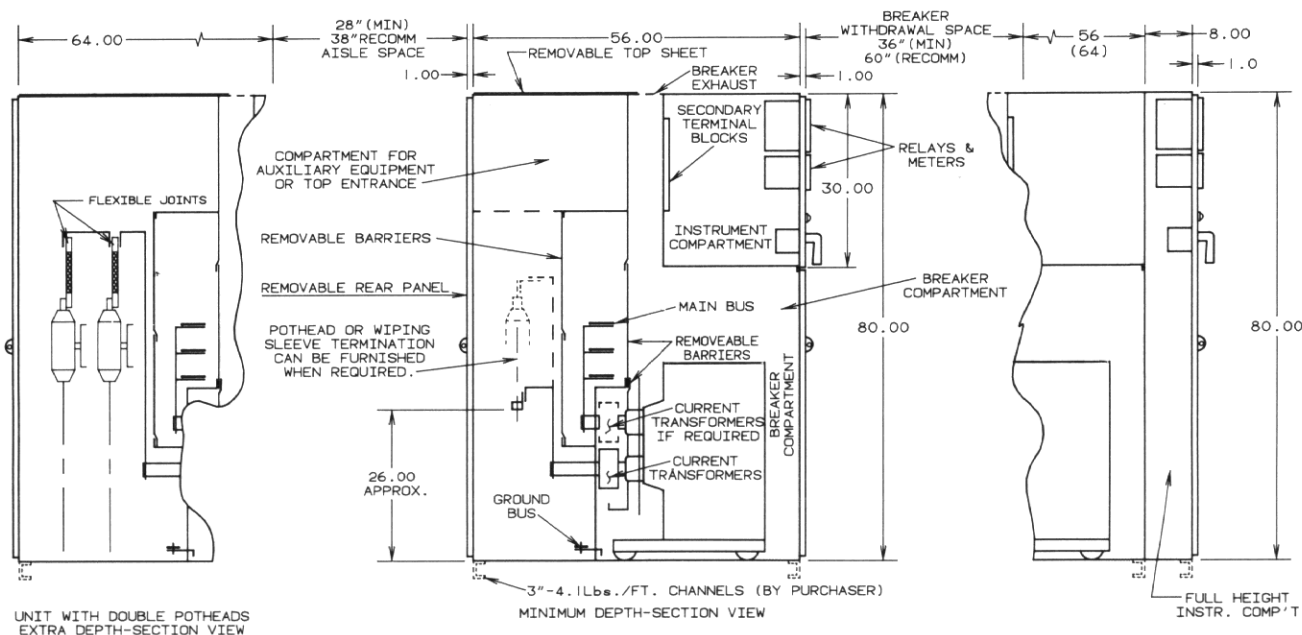

**TYPICAL FLOOR PLAN – ONE HIGH CONSTRUCTION
5KV-250MVA**

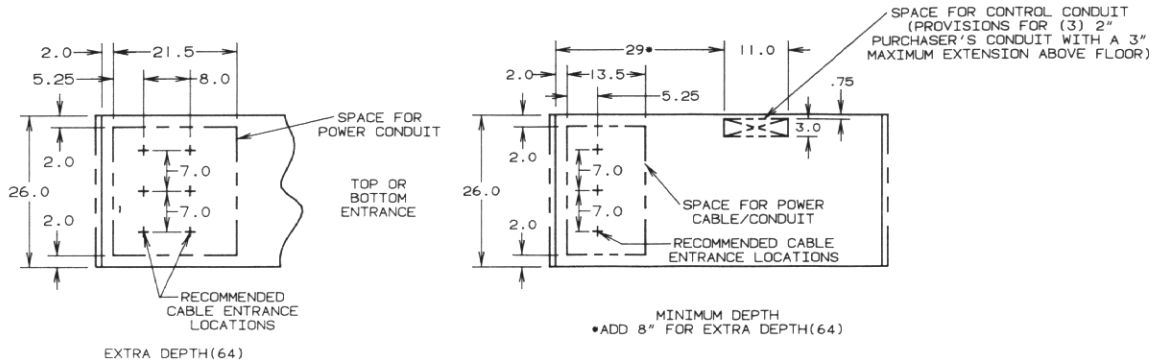

**TYPICAL OUTDOOR NON WALK-IN SWITCHGEAR
5KV-250MVA – ONE-HIGH CONSTRUCTION**

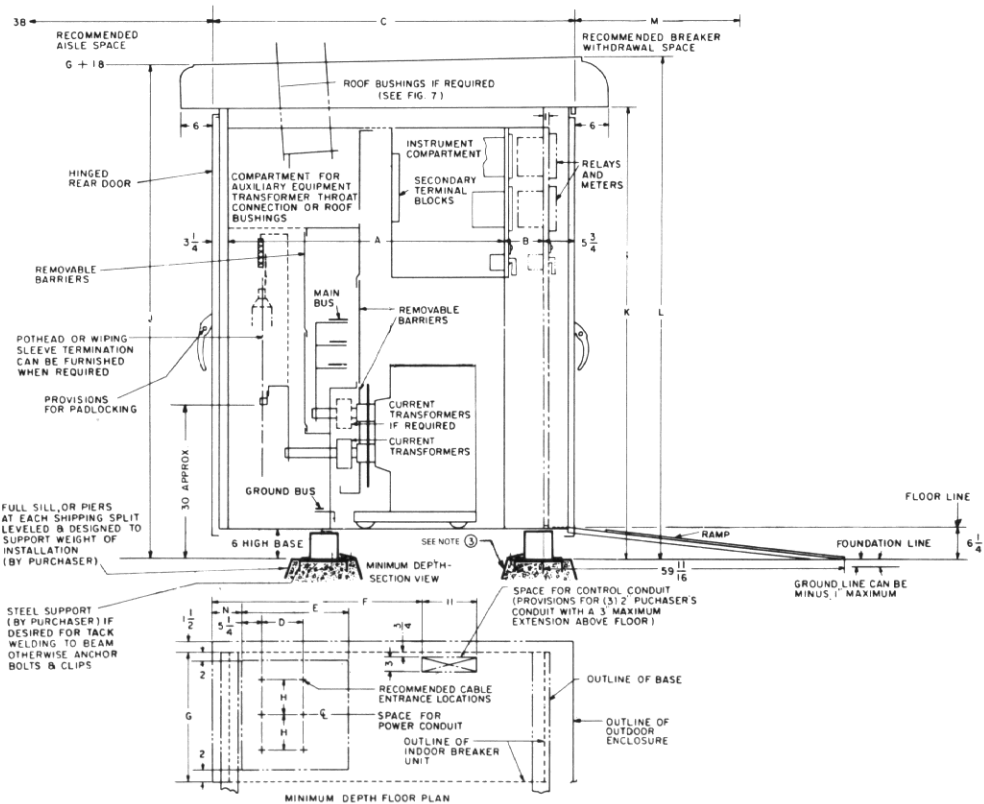

Breaker Type	Outdoor Construction	A	B	C	D	E	F	G	H	J	K	L	M	N
5 VHK 250 1200 Amp 2000 *	Minimum Depth	56	—	65	—	13½	32¼							
	Intermediate Depth (Full Height Instrument Compartment)		8	73				26	7	98½ ₁₆	90¼	101¾	120	5¼
	Extra Depth (Special Application) (Full Height Instrument Compartment) (Additional 8" in Rear)	64		81	8	21½	40¼							

Dimensions are in inches. They are approximate and should not be used for construction.
*When 3000A breaker in line-up consult nearest ABB Power Distribution, Inc. office.

TYPICAL OUTDOOR SINGLE & DOUBLE ROW WALK-IN SWITCHGEAR 5KV-250MVA – ONE-HIGH CONSTRUCTION

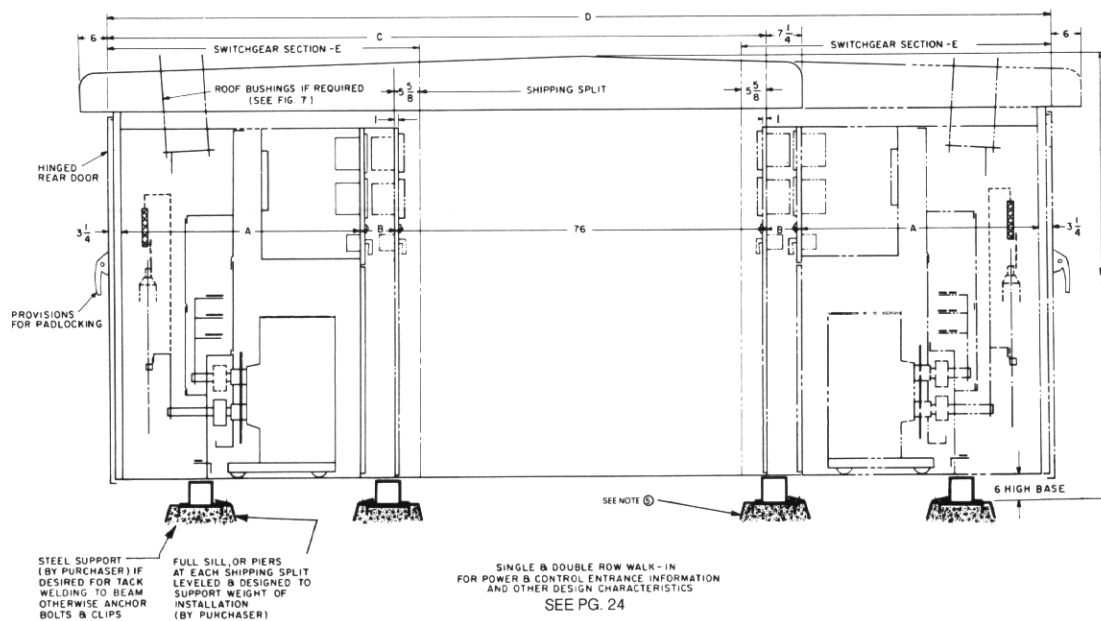

Breaker Type	Outdoor Construction	A	B	C	D	E	F
5 VHK 250 1200 Amp 2000 *	Minimum Depth	56	—	135 ¼	194 ½	64 ¾	102 ¾
	Intermediate Depth (Full Height Instrument Compartment)		8	143 ½	210 ½	72 ¾	
	Extra Depth (Special Application) (Full Height Instrument Compartment) (Additional 8" in Rear)	64		151 ¼	226 ½	80 ¾	

Dimensions are in inches. They are approximate and should not be used for construction.
 *When 3000A breaker in line-up consult nearest ABB Power Distribution, Inc. office.

General

Metal-clad switchgear featuring vacuum or SF₆ circuit breakers is most properly applied as protective equipment on power systems where the user requires (a) personnel safety; (b) system stability and reliability; (c) adaptability; (d) minimal maintenance; and, (e) low total cost. Personnel safety is one of the prime reasons for user insistence on metal-clad switchgear to perform the power system protective function. Electricity by its very nature is extremely dangerous and entails considerable personnel hazard if not adequately controlled. Metal-clad switchgear enhances system stability and reliability because of its basic construction features and flexibility derived from the multitude of main bus configurations available to the user. It is adaptable to many applications because it is easily expanded and can be specified and designed with load location and load characteristics in mind. Reduced maintenance cost is a result of the drawout features of metal-clad switchgear, as well as superior accessibility of most components. All this at a reduced total cost to the user. On the average, metal-clad switchgear represents approximately 5% of plant cost. This class of switchgear is generally shipped factory assembled and reduces the need for expensive field assembly.

The application of metal-clad switchgear is a relatively simple procedure in most cases. The following steps are normally taken in applying this equipment:

1. Develop single-line diagram and general arrangement (see pages 14-25).
2. Determine required breaker based on applied voltage, continuous current and interrupting capability (see page 33).
3. Select main bus rating.
4. Select current transformer ratios.
5. Select potential transformers and how connected.

6. Select protective relays and meters.
7. Determine closing, tripping and power requirements.
8. Consider special applications.

Bus arrangements

Essentially all recognized basic bus arrangements are available in metal-clad switchgear to insure the desired system reliability and flexibility. A choice is made based on an evaluation of initial cost, operating procedures and system requirements. Refer to the following for some basic bus arrangements and considerations to evaluate when making the ultimate choice.

Common bus arrangements

Straight Bus (Radial)

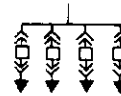

Advantages: • Low initial cost • Readily adapts to standard indoor or outdoor construction • High reliability factor due to simplicity of system design • Simplified coordination.

Disadvantages: • Inspection, maintenance or repair requires interruption of service • Selectivity between feeders and main crucial if shutdown is to be prevented.

Double Bus - Double Breaker

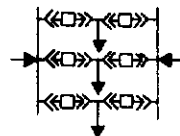

Advantages: • Good reliability factor • Lends itself to either outdoor (double row walk-in) or indoor metal-clad construction • Provides physical isolation between source buses • Allows inspection and maintenance without load interruption.

Disadvantages: • High cost factor • Increased floor area for 3000A bus • Complex operating procedures.

Breaker and Half Scheme



Advantages: • Good reliability factor • Inspection and maintenance

without load interruption • Lends itself to a continuous line arrangement.

Disadvantages: • High cost factor • Additional floor area may be required, depending on final equipment layout.

Main and Transfer Bus

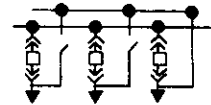

Advantages: • Provides switching flexibility at reduced cost • Can be provided in a continuous line arrangement • Adaptable to either indoor or outdoor construction • Breakers and disconnect switches can be located in common unit.

Disadvantages: • Interlocking required involving sequential operation of breaker with interlocked switch • Breaker and switch operating mechanism on opposite sides of assembly • Relaying through transfer bus impractical with two or more switches closed • Fault condition on one circuit may cause interruption to several circuits being served by transfer bus.

Sectionalized Bus

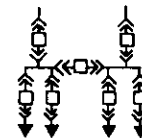

Advantages: • Single bus provides reduced cost over double bus arrangement • Intermediate flexibility and reliability attained through power transfer equipment • Extended reliability can be provided by paralleling feeders to critical loads • Adapts readily to standard construction configurations.

Disadvantages: • Momentary load interruption probable during transfer operation • Delay in transfer may be required to allow decay in residual voltage on down side of this breaker • Momentary paralleling of supplies may exceed breaker rating.

Synchronizing Bus

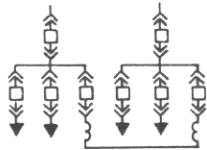

Advantages: • Basic advantages duplicate those of the sectionalized bus but with increased reliability through the addition of sources. Prime advantage is that reactor bus allows strategic installation of current limiting reactors.

Disadvantages: • Basic disadvantages duplicate those of sectionalized bus with increased complexity in relaying of power transfer.

Ring Bus

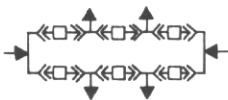

Advantages: • Good reliability and flexibility • Low initial cost when compared to a double bus arrangement • Can be arranged in single row line-up • Adapts to either indoor or outdoor construction • Can be designed to accommodate a multiple-source arrangement.

Disadvantages: • Relaying increases in complexity as resources are added.

Breaker selection

Usually, the principal function of power circuit breakers is to carry load current and provide a means for the interruption of short-circuit current. Continuous current ratings of power circuit breakers are generally contingent on feeder and main breaker loading. The breaker interrupting capacity (IC) must be sufficient to safely interrupt the maximum short circuit current that the power system can deliver with a three phase bolted fault applied to the terminals of the circuit breaker. Sometimes frequent switching or reclosing may be the determining factor in breaker selection, rather than the requirements of continuous

current rating and/or short-circuit current interruption.

Unusual service conditions as defined in ANSI C37.04 must be considered when applying power circuit breakers. Such conditions should be brought to the attention of the circuit breaker manufacturer at the earliest possible time. Some special application considerations and unusual service conditions are discussed on page 31.

Power circuit breakers are sometimes used for reclosing duty to maintain service continuity. When applied in this manner the interrupting capacity of the breaker must be derated in accordance with Figure 1.

A complete line of power circuit breakers is available. They are listed on page 32, Tables 4 and 5. Repetitive duty capability and normal maintenance requirements are listed in Table 1, page 27.

Capability factors for automatic reclosing circuit breakers

The following standard capability factors apply to all a-c high-voltage circuit breakers as shown in American National Standard Schedules of Preferred Ratings and Related Required Capabilities for AC High-Voltage Circuit Breakers, C37.06 — 1987 which are rated below 72.5 kV and have continuous current ratings of 1,200 amperes and below. Breakers with continuous current ratings above 1,200 amperes are not intended for reclosing service applications. When such applications arise, contact the nearest ABB Representative.

A duty cycle shall not contain more than 5 opening operations.

All operations within a 15-minute period are considered part of the same duty cycle.

General:

The circuit breaker may be applied at the determined operating voltage and duty cycle to a circuit whose calculated short circuit does not

exceed the symmetrical interrupting capability as determined.

If the X/R ratio for the circuit exceeds 15, refer to ANSI C37.010 — 1989 for complete information.

Step #1 Determine the breaker symmetrical interrupting capability at the operating voltage from Tables.

Step #2 Determine the factor of d_1 from the reclosing capability curve in Fig. 1 for the current value determined in step #1.

Step #3 The symmetrical interrupting capability of the breaker for the operating voltage and duty cycle desired is now determined by multiplying the step #1 symmetrical interrupting capability by reclosing capability factor R from Fig. 2 (for duty cycles listed).

Figure 1

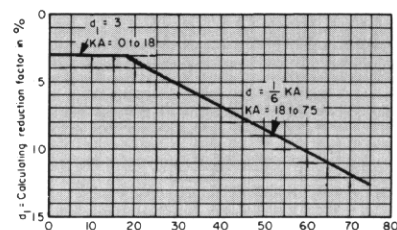

Breaker symmetrical interrupting capability in kiloamperes at operating voltage

Fig. 1 AC High-Voltage Circuit Breaker Interrupting Capability Factors for Reclosing Service

$$R = 100 - D(\%)$$

$$D = d_1(n-2) + d_1 \frac{(15-t_1)}{15} + d_1 \frac{(15-t_2)}{15} + \dots$$

D = total reduction factor in percent

d_1 = calculating factor for D in percent of breaker symmetrical interrupting capability at operating voltage

n = total number of openings

t_1 = first time interval less than 15 sec.

t_2 = second time interval less than 15 sec.

Figure 2

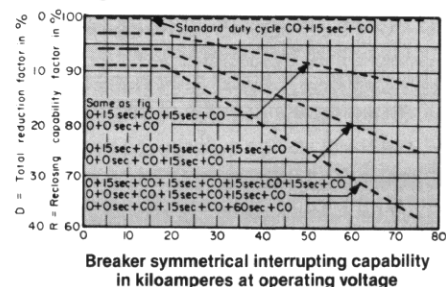

Fig. 2 Examples of Popular Reclosing Capabilities

Repetitive duty and normal maintenance for other than arc furnace switching

Power circuit breakers, when operating under usual service conditions, are capable of operating the required number of times given in Table 1. The operating conditions and the permissible effect upon the breakers are specified in the notes.

For each column, all notes listed must be given consideration. (Reference ANSI C37.06—1987. As a guide for **capacitor or reactor switching**, use values listed in column 5 only. For back-to-back switching applications refer to the nearest ABB Representative.

Table 1

Breaker		Maximum No. of Operations Between Servicing (Note A)	Number of Operations				
Type	Continuous Current, A		No load Mechanical (Notes B, E, F, G, H, I)	Full-load Non-Fault (Notes C, E, F, G, H, J)	Full-load Fault (Notes D, E, F, G, H, I, K)	Inrush Non-Fault (Notes D, E, F, G, H, J)	Inrush Fault (Notes D, E, F, G, H, I, K)
Column 1	Column 2	Column 2	Column 3	Column 4	Column 5	Column 6	Column 7
5VHK-250	1200	2000	10000	5000	1000	3000	750
5VHK-250	2000			3000		2000	
5VHK-350	1200	1000	5000	2500	500	1500	400
5VHK-350	2000						
5VHK-350	3000						
7.5VHK-500 or GHK-500	1200	2000	10000	5000	1000	3000	750
7.5VHK-500 or GHK-500	2000			3000		2000	
15VHK-500 or GHK-500	1200	2000	10000	5000	1000	3000	750
15VHK-500 or GHK-500	2000			3000		2000	
15VHK-750 or GHK-750	1200	2000	10000	5000	1000	3000	750
15VHK-750 or GHK-750	2000			3000		2000	
15VHK-1000	1200	1000	5000	2500	500	1500	400
15VHK-1000	2000						
15VHK-1000	3000						

NOTES:

Servicing

A. Servicing shall consist of adjusting, cleaning, lubricating, tightening, etc., as recommended by applicable installation and maintenance manuals. The operations listed are on the basis of servicing at intervals of six months or less.

Circuit Conditions

B. When closing and opening no load.
 C. When closing and opening currents up to the continuous current rating of the breaker at voltages up to the maximum design voltage and at 80 percent power factor or higher.

D. When closing currents up to 600 percent and opening currents up to 100 percent (80 percent power factor or higher) of the continuous current rating of the breaker at voltages up to the maximum design voltage.

Operating Conditions

E. With up to rated control voltage applied.
 F. Frequency of operation not to exceed 20 in 10 minutes or 30 in 1 hour. Rectifiers or other auxiliary devices may further limit the frequency of operations.
 G. Servicing at not greater intervals than shown in Column 2.

Condition of the Breaker After the Operations Shown in the Table.

H. No parts shall have been replaced.
 I. The breaker shall meet all of its current, voltage and interrupting ratings.
 J. The breaker shall meet all of its current and voltage ratings but not necessarily its interrupting ratings.

Operation Under Fault Conditions

K. If a fault operation occurs before the completion of the permissible operations, it is not to be inferred that the breaker can meet its interrupting rating or complete its number of operations without servicing and making replacements if necessary.

Main bus rating

The continuous current rating of the switchgear main bus should normally match that of the main circuit breaker. With a single incoming line, HKII switchgear has standard, 60 Hz continuous current ratings of 1200, 2000 and 3000 amperes.

The rated continuous current of a switchgear assembly is the maximum current in rms amperes, at rated frequency, which can be carried continuously by the primary circuit components without causing temperatures in excess of limits specified in ANSI C37.20.

The main bus will be designed and rated for the full ampere capacity specified and will not be tapered for the purpose of reducing current densities. As power system facilities must be increased from time to time to serve larger loads, it is advisable to consider future expansion when selecting the bus continuous current rating.

The switchgear assembly should have momentary and short-time ratings equal to the close and latch capability and short-time rating of the circuit breaker. Applicable ratings of VHK and GHK circuit breakers are listed in Tables 4 and 5, page 33.

Current transformers

(See Tables 12-16, pages 35-36.)

Current transformers are used to transform primary currents into secondary terms, usually 5 amperes. They are used in the application of instruments meters and relays. In switchgear applications, they are of the toroidal-type construction. They are manufactured in single-secondary, and multi-ratio types, whichever is required.

Current transformers are used to isolate the primary circuit from the secondary auxiliary equipment and to lower the applicable amperes to a safe and usable value. They are selected so that all ratings such as impulse, dielectric and voltage are to be equal to or greater than that of the circuit breaker; the primary current rating to be equal to approximately

125 percent of the normal primary current in the circuit; the mechanical strength of the transformer is to be equal to or greater than that of the breaker; and, the metering and/or, relaying accuracy must be adequate for the imposed burdens.

Potential transformers

(See Table 11, page 35.)

Potential transformers are used to transform primary voltages into secondary terms, usually 120 volts. The primary rating of a potential transformer is that which is equal to, or higher than the system voltage. For instance, on a 13,800 volt system, a potential transformer with a standard 14,400 volt primary rating is used. As in the use of current transformers, potential transformers are used for instrumentation, metering or relaying.

Potential transformers are used to isolate the primary circuit from the secondary auxiliary equipment and to lower the voltage to a safe and usable value. They are selected so that all ratings such as impulse, dielectric, etc., must be equal to or greater than the breaker; the accuracy of the transformers must be adequate; and, the primary voltage rating must be equal to or greater than the system voltage.

Control power requirements

(See Table 10, page 35.)

General

The choice of the source of closing and tripping power used in metal-clad switchgear depends upon many factors. Among these factors are the number of circuit breakers in the installation, the number of breakers required to close simultaneously, control power requirements needed for purposes other than operating the circuit breakers, type of circuit breaker mechanism, availability of adequate housing facilities for a battery and its associated charging equipment and future expansion of the system to justify a shift in eco-

nomie preference from an a-c to d-c control power source.

VHK and GHK Power circuit breakers are held in the closed position by a mechanical latch. They are designed to close and latch up to the "close and latch" rating listed in Tables 4 and 5. There is no requirement for a continuous supply of electric power to hold the circuit breaker in the closed position. This allows the circuit breaker to provide maximum continuity of service and speed of operation. However, closing power and a fully reliable source of electric power for tripping are needed. Closing and tripping power requirements of VHK and GHK breakers are listed in Tables 6 and 7, page 34.

Closing Power

Due to the low-energy closing requirements of the VHK and GHK stored-energy mechanisms a 48-volt d-c operating battery is an acceptable source of tripping power for many applications of metal-clad switchgear. However, some applications, such as large industrial plants, and where d-c power will be used for circuit breaker tripping and closing or operating control, a 125-volt battery may be preferable. There are also instances where a dependable source of auxiliary control power may be required for various emergency services. A station battery is generally the only practical source of electric power for these requirements. See Table 6, page 34.

Often, the investment required to provide d-c closing power is unwarranted when compared to the initial cost of metal-clad switchgear. In these instances, a-c closing power supplied from control power transformers connected to the switchgear's power system is more economical, with capacitor tripping utilized for safety.

Some basic configurations for providing closing power are shown in Figures 3, 4, 5 and 6 below. Figure 3 represents a simplified schematic of a typical d-c closing power arrangement. Figure 4 shows a-c closing power derived from a

control power transformer connected directly to the power system. Also, a-c operation of the stored-energy mechanism can be taken from a lighting or some other general purpose source as illustrated in Figure 5. As VHK and GHK stored energy mechanisms charge the closing springs immediately following closing, the energy for the next closing operation is automatically stored in the closing springs, thereby allowing a trip-close-trip sequence of operations if closing power should be lost subsequent to closure of the circuit breaker. The stored-energy mechanism also allows for complete manual operation as shown in Figure 6.

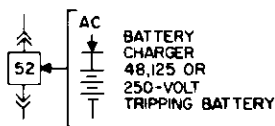

FIG. 3. D-C stored-energy close

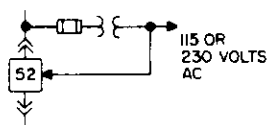

FIG. 4. A-C stored-energy close

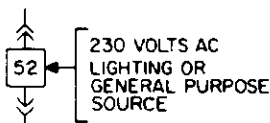

FIG. 5. A-C stored-energy close

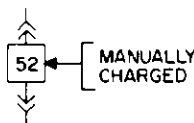

FIG. 6. Manually stored-energy close

Tripping Power

Since a battery is not affected by the power circuit voltage and current conditions during time of fault, it is

considered the most dependable source of tripping power. The battery is sometimes further provided with sufficient ampere-hour capacity to carry emergency lighting loads if a protracted outage of a-c power should occur.

Metal-clad switchgear applied in many electrical installations employs a 125-volt operating battery as the source of tripping power. Most of the smaller metal-clad switchgear installations, however, generally use 230-volt a-c power for control, indication and circuit breaker closing purposes, with a 24- or 48-volt tripping battery as the source of reliable power for circuit breaker tripping.

When a 125-volt d-c battery is used for closing power, it is generally also utilized for the breaker tripping circuits. A 48-volt tripping battery is recommended for tripping power applications where a 125-volt battery is not available or is not justifiable. It is particularly satisfactory if more than one lineup of metal-clad switchgear is being served or where appreciable distances are involved. 48 v spring charging is not recommended.

Reliable tripping power requires that the battery be properly maintained. Proper maintenance includes keeping the battery fully charged and the electrolyte maintained at the required level and density to ensure a long life. Also, care should be taken to avoid exposure of the battery to extremely low ambient temperatures which cause reduced voltage output, thereby jeopardizing the battery's circuit breaker tripping capability.

Capacitor Trip

As discussed above, a tripping battery requires some maintenance if it is to remain a dependable source of tripping power. Consequently, on some smaller metal-clad switchgear installations, a capacitor energized trip device has been employed. This device has the advantages of reduced space and minimum maintenance requirements. However, it has the

serious limitation of being able to provide ample tripping power from the capacitor charge for only a short time should the a-c control voltage fail. Tripping power from the capacitor trip unit may not be available to trip a breaker when an attempt is made to re-energize a bus if a fault had occurred on a circuit while the bus was dead. This could occur during maintenance, construction or reconstruction, test operation or during a storm. This limitation has further prevented the use of capacitor tripping schemes for many applications. It is important to note that when a capacitor-energized trip device is applied as a source of tripping power, it must be supplied for each breaker and its auxiliary tripping relay(s) in its respective cubicle.

Power for other uses

Closing or tripping power may be used for purposes other than closing or tripping power circuit breakers. Power for various control purposes such as space heaters, convenience outlets, lighting, indicating-lamp circuits, exhaust fan motors, sequential and interlocking circuits of automatic equipment, etc. is generally derived from the closing power source. However, should the circuits involved be an integral part of the protective scheme and not embody a continuously energized device, tripping power is used as the source of control power.

Space heaters are supplied as standard on outdoor metal-clad switchgear in accordance with Table 34. Often, ambient temperature or other environmental conditions dictate the use of space heaters in indoor metal-clad switchgear as well. When space heaters are furnished, it is recommended that they be continuously energized by an a-c power source. If a-c closing power is available, this source can also be used for the heaters provided it is of sufficient capacity to supply the continuous current requirements of the space heaters and the inrush loading of breaker closing.

Table 2 — Maximum 3-phase, single-capacitor-bank switching

Rated Maximum Voltage KV rms	Rated Short-Circuit Current KA rms	VHK or GHK Breaker Continuous Current Rating*			
		1200A		2000A	
		General Purpose	Definite Purpose	General Purpose	Definite Purpose
4.76	29	400	630	400	1000
4.76	41	400	630	400	630
8.2	33	250	630	250	1000
15.0	18	250	630	250	1000
15.0	28	250	630	250	1000
15.0	37	250	630	250	630

NOTES: Ratings are subject to the following conditions:

1. The transient voltage from line to ground shall not exceed 3 times maximum design line-to-ground crest voltage measured at the breaker terminals.
2. The number of restrikes or reignitions shall not be limited as long as the transient voltage to ground does not exceed the value given in Note 1.
3. The capacitor rating applies only to "Single Bank Switching" as noted herein.
4. Interrupting time is in accordance with the rated interrupting time of the circuit breaker.

*For 3,000A, refer to the nearest ABB representative.

Quality assurance

The intent of the Quality Assurance Program is to provide assurance that the finished switchgear and associated accessories perform and conform to all applicable specifications and drawings prior to shipment and assures that all items reach their destination in the condition ready for service. It is also the intent of the quality control system to employ sufficient control throughout the various stages of manufacturing, assembly and testing to assure that the quality level of the finished products is achieved in the most efficient and economical manner.

Seismic requirements

HKII switchgear conforms with the requirements of the Uniform Building Code (U.B.C.) Zones 0 through 4. For any seismic requirement in excess of the U.B.C. please contact your nearest ABB Representative with the specifics.

NEC & OSHA requirements

NEC generally describes para-

meters and techniques for a safe installation, which is also the concern of OSHA. Our switchgear is supplied with the provisions for safe installation. If there are any questions regarding ABB equipment relative to above requirements, contact the nearest ABB representative for latest information.

Special Application Considerations

Reactor switching

VHK & GHK power circuit breakers are capable of switching reactive load current up to their full continuous current rating. Reactor switching applications wherein the reactor(s) are in close proximity (within ten feet) of the circuit breaker(s) should be referred to the nearest ABB representative for consideration.

Capacitor switching

Standard VHK & GHK power circuit breakers are capable of switching capacitors, single or back-to-back, in accordance with the data outlined in Table 2.

Capacitor installations are generally applied on both utility and industrial power systems to improve voltage regulation, enhance system stability and to provide for system expansion.

The shunt bank or back-to-back capacitor switching application means either connecting or disconnecting a capacitor bank to or from a bus to which a single bank, equal to or less than the switching bank, is already connected. Generally, VHK & GHK power circuit breakers can switch any capacitor bank as long as the breaker's continuous current rating equals or exceeds 1.35 times the nominal current rating of the capacitor bank. However, for complex capacitor switching applications or where frequent switching is contemplated, contact the nearest ABB representative for recommendations.

Automatic Bus Transfer Times for Station Auxiliaries

Importance of bus transfer times

Bus transfer can be initiated under two conditions. The first condition is called **routine transfer** and is done when the generating unit is started up or shut down. The second condition is called **emergency transfer** and is necessary upon failure of the normal source of power. Routine transfer can be handled in many ways and the problems incurred are generally minor. However, automatic bus transfer of station auxiliaries under emergency conditions, whether for industrial, commercial or utility stations, must be accomplished with a minimum dead bus time.

Bus transfer times should be held to some low value because motors slow down and go out of phase. With these conditions, if the emergency source is energized, there will be large inrush currents. This is undesirable and could result in total loss of the bus under certain conditions. Consequently, there must be a coordinated bus transfer time to keep these conditions to a minimum.

VHK/GHK breaker dead bus transfer times

Table 3 lists the dead bus transfer times of ABB power circuit breakers normally applied on generating station auxiliary circuits:

Table 3 – VHK and GHK breaker dead bus transfer times

Breaker Type	Dead bus transfer time, ms (cycles) Δ*			
	Continuous Current Rating, A	Simultaneous Trip & Close (No arcing)	Simultaneous Trip & Close (With arcing)	Trip then Close using Standard "b" Contact (With arcing)
5 VHK 350	1200	50(3)	20(1.2)	85(5.1)
	2000	50(3)	20(1.2)	85(5.1)
	3000	55(3.3)	25(1.5)	120(7.2)
7.5VHK 500	1200			
7.5GHK 500	2000	95(5.7)	55(3.3)	130(7.8)
	3000			
15VHK 500	1200			
15GHK 500	2000	95(5.7)	60(3.6)	145(8.7)
15VHK 750	1200			
15GHK 750	2000	95(5.7)	55(3.3)	130(7.8)
	3000			

Δ All times shown are nominal.

Tolerance on dead time is ± 16.7ms (1 cycle).

* Special interlocking is available to prevent closing of second breaker if first breaker would fail to open on 7.5 and 15HK type.

Required dead bus transfer times

There seems to be two prevalent choices of required dead bus time: 50ms (three cycles) or 100ms (six cycles). Of these 100ms (six cycles) is indicated to be generally preferred. Accordingly, this can be thought of as a significant level of comparison with the dead bus transfer times of the breaker types listed in Table 3 above.

Forced air cooling

Additional ratings are available, utilizing forced air cooling, for even greater ampacity. Consult the nearest ABB representative for latest data.

25 Hertz application

VHK and GHK circuit breakers are rated at 60 Hertz, but can be applied as low as 50 Hertz without derating. For 25 Hertz application, however, there is a derating factor which must be applied to the breaker's interrupting rating as follows:

Type Breaker	Interrupting Rating MVA	Derating Factor
5 VHK	250	1.00
	350	0.85
7.5 VHK 7.5 GHK	500	0.85
15 VHK 15 GHK	500	0.75
	750	0.75
15 VHK	1000	0.75
	27 GHK	500 750 1000

Unusual service conditions

High altitude

American National Standards Institute (ANSI) Standard C37-04-1989, paragraph 04-3.2.2, indicates that high-voltage a-c power circuit breakers applied at altitudes greater than 3,300 feet must have their **dielectric withstand, continuous current, and voltage** ratings derated as follows:

Altitude (ft.)	Rating Correction Factor*	
	Continuous Current	Voltage & Dielectric Withstand
3,300 (and below)	1.00	1.00
5,000	0.99	0.95
10,000	0.96	0.80

*Values for intermediate altitudes may be derived from linear interpolation.

When applying these rating correction factors to voltage, always use the circuit breaker maximum design voltage. When derating continuous current, be careful that the derated value is not less than required full load currents. Be especially alert to dual-rated breakers with forced-air cooling.

Type VHK Circuit Breakers

Application data

Table 4 – Vacuum power circuit breakers – Ratings on a symmetrical basis.

Type of Breaker	Nominal Rating		Rated Continuous Current 60 Hertz AMPS-RMS	Rated Voltages			Insulation Level Rated Withstand			Interrupting Ratings† AMPS-Symmetrical			○ Asymmetrical Rating Factor	Short Time Rating 3 Sec. AMPS-RMS	Close and Latch Rating AMPS-RMS	Inter-rupting Time Cycles
	Three-Phase MVA	Voltage KV-RMS		Maximum Voltage KV-RMS	K-Factor Max. KV	Minimum Voltage KV-RMS	Low Frequency KV-RMS	Impulse Δ 1.2x50 MS KV-Crest	Maximum KV	Nominal KV	Minimum KV	AMPS-RMS				
5 VHK 250	250	4.16	1,200	4.76	1.24	3.85	19.	60.	29,000	33,000	36,000	1.2	37,500	60,000	3	
5 VHK 250	250	4.16	2,000	4.76	1.24	3.85	19.	60.	29,000	33,000	36,000	1.2	37,500	60,000	3	
5 VHK 350	350	4.16	1,200	4.76	1.19	4.00	19.	60.	41,000	47,000	49,000	1.2	50,000	80,000	3	
5 VHK 350	350	4.16	2,000	4.76	1.19	4.00	19.	60.	41,000	47,000	49,000	1.2	50,000	80,000	3	
5 VHK 350	350	4.16	3,000	4.76	1.19	4.00	19.	60.	41,000	47,000	49,000	1.2	50,000	80,000	3	
7.5 VHK 500	500	7.20	1,200	8.25	1.25	6.6	36.	95.	33,000	38,000	41,000	1.2	44,000	70,000	3	
7.5 VHK 500	500	7.20	2,000	8.25	1.25	6.6	36.	95.	33,000	38,000	41,000	1.2	44,000	70,000	3	
7.5 VHK 500	500	7.20	3,000	8.25	1.25	6.6	36.	95.	33,000	38,000	41,000	1.2	44,000	70,000	3	
15 VHK 500	500	13.8	1,200	15.0	1.30	11.5	36.	95.	18,000	20,000	23,000	1.2	25,000	40,000	3	
15 VHK 500	500	13.8	2,000	15.0	1.30	11.5	36.	95.	18,000	20,000	23,000	1.2	25,000	40,000	3	
15 VHK 500	500	13.8	3,000	15.0	1.30	11.5	36.	95.	18,000	20,000	23,000	1.2	25,000	40,000	3	
15 VHK 750	750	13.8	1,200	15.0	1.30	11.5	36.	95.	28,000	30,000	37,000	1.2	37,500	60,000	3	
15 VHK 750	750	13.8	2,000	15.0	1.30	11.5	36.	95.	28,000	30,000	37,000	1.2	37,500	60,000	3	
15 VHK 750	750	13.8	3,000	15.0	1.30	11.5	36.	95.	28,000	30,000	37,000	1.2	37,500	60,000	3	
15 VHK 1000	1,000	13.8	1,200	15.0	1.30	11.5	36.	95.	37,000	40,000	48,000	1.2	50,000	80,000	3	
15 VHK 1000	1,000	13.8	2,000	15.0	1.30	11.5	36.	95.	37,000	40,000	48,000	1.2	50,000	80,000	3	
15 VHK 1000	1,000	13.8	3,000	15.0	1.30	11.5	36.	95.	37,000	40,000	48,000	1.2	50,000	80,000	3	

Notes: † — For operating voltages other than those listed, the interrupting Current = Amps at Max. KV $\frac{\text{Max. KV}}{\text{Operating KV}}$ but in no case can this current exceed the interrupting Current at Minimum KV.

○ — Rating factor is based on breaker speed from initiation to contact parting with 1/2 cycle relay time. Multiply factor X symmetrical current to obtain asymmetrical current interrupting capability of breaker.

Notes: Δ — These values apply with circuit breaker in or out of switchboard.

Type GHK Circuit Breakers

Application data

Table 5 – SF₆ gas power circuit breakers – Ratings on a symmetrical basis.

Type of Breaker	Nominal Rating		Rated Continuous Current 60 Hertz AMPS-RMS	Rated Voltages			Insulation Level Rated Withstand			Interrupting Ratings† AMPS-Symmetrical			○ Asymmetrical Rating Factor	Short Time Rating 3 Sec. AMPS-RMS	Close and Latch Rating AMPS-RMS	Inter-rupting Time Cycles
	Three-Phase MVA	Voltage KV-RMS		Maximum Voltage KV-RMS	K-Factor Max. KV	Minimum Voltage KV-RMS	Low Frequency KV-RMS	Impulse Δ 1.2x50 MS KV-Crest	Maximum KV	Nominal KV	Minimum KV	AMPS-RMS				
7.5 GHK 500	500	7.20	1,200	8.25	1.25	6.6	36.	95.	33,000	38,000	41,000	1.2	44,000	70,000	5	
7.5 GHK 500	500	7.20	2,000	8.25	1.25	6.6	36.	95.	33,000	38,000	41,000	1.2	44,000	70,000	5	
15 GHK 500	500	13.8	1,200	15.0	1.30	11.5	36.	95.	18,000	20,000	23,000	1.2	25,000	40,000	5	
15 GHK 500	500	13.8	2,000	15.0	1.30	11.5	36.	95.	18,000	20,000	23,000	1.2	25,000	40,000	5	
15 GHK 750	750	13.8	1,200	15.0	1.30	11.5	36.	95.	28,000	30,000	37,000	1.2	37,500	60,000	5	
15 GHK 750	750	13.8	2,000	15.0	1.30	11.5	36.	95.	28,000	30,000	37,000	1.2	37,500	60,000	5	
27 GHK 500	500	25.0	1,200	27.0	1.00	19.0	60.	125.	16,000	16,000	16,000	1.2	16,000	26,000	5	
27 GHK 500	500	25.0	2,000	27.0	1.00	19.0	60.	125.	16,000	16,000	16,000	1.2	16,000	26,000	5	
27 GHK 750	750	25.0	1,200	27.0	1.00	19.0	60.	125.	20,000	20,000	20,000	1.2	20,000	32,000	5	
27 GHK 750	750	25.0	2,000	27.0	1.00	19.0	60.	125.	20,000	20,000	20,000	1.2	20,000	32,000	5	
27 GHK 1000	1,000	25.0	1,200	27.0	1.00	19.0	60.	125.	25,000	25,000	25,000	1.2	25,000	40,000	5	
27 GHK 1000	1,000	25.0	2,000	27.0	1.00	19.0	60.	125.	25,000	25,000	25,000	1.2	25,000	40,000	5	

Notes: † — For operating voltages other than those listed, the interrupting Current = Amps at Max. KV $\frac{\text{Max. KV}}{\text{Operating KV}}$ but in no case can this current exceed the interrupting Current at Minimum KV.

○ — Rating factor is based on breaker speed from initiation to contact parting with 1/2 cycle relay time. Multiply factor X symmetrical current to obtain asymmetrical current interrupting capability of breaker.

Notes: Δ — These values apply with circuit breaker in or out of switchboard.

Table 6 – Operating Voltage Range

Nominal Control Voltage	Spring Charging Motor	Close Coil	Trip Coil
* 24 V DC	—	—	14– 30
Δ 48 V DC	† 35– 50	35– 50	28– 60
125 V DC	90–130	90–130	70–140
250 V DC	180–260	180–260	140–280
115 V AC	95–125	95–125	‡ 95–125
230 V AC	190–250	190–250	‡190–250

NOTES:

– Unless the circuit breaker is located close to the battery and protective relay and adequate electrical connections are provided between the battery and trip coil, 24 volt DC tripping is not recommended.

† 48 VDC spring charging is not recommended.

‡ AC tripping is not recommended (see page 30).

Table 7 – Current Values – Voltage shown in Table 7.§

Spring Charging Motor	Close Coil	Trip Coil	Lockout Coil
—	—	22.0	—
† 20.0	10.7	10.7	0.15
10.0	5.0	5.0	0.06
5.0	2.2	2.2	0.03
10.0	4.5	4.5	0.04
5.0	2.3	2.3	0.20

§ **Current values are average steady state values – momentary inrush currents for all charging motors and AC coils are approximately 6 – 8 times these values, an important consideration when sizing the battery.**

Δ 48 volt tripping or closing functions are not recommended, except when the device is located near the battery or where special effort is made to insure the adequacy of conductors between battery and control terminals.

Table 8 – VHK/GHK Breaker Time Characteristics

Breaker	Av. Closing	Av. Tripping	Av. Spring Charging	Interrupting Time 0 – 100% of Rating
5 VHK 250	3 cycles	2 cycles	2 seconds	3cycles
15 VHK 500/750	3 cycles	2 cycles	2 seconds	3 cycles
7.5 VHK 500	3 cycles	2 cycles	2 seconds	3 cycles
5 VHK 350	3.5 cycles	2.5 cycles	2 seconds	3 cycles
15 VHK 1000	3.5 cycles	2.5 cycles	2 seconds	3 cycles
15/27 GHK 500/750/1000	3.5 cycles	2 cycles	2 seconds	5 cycles

Closing Time — Between energizing closing coil and making of arcing contacts.

Tripping Time — Between energizing of trip coil and parting of arcing contacts.

Interrupting Time — Between energizing trip coil and complete interruption.

Table 9 – Space Heaters for Outdoor Equipment*

Type Unit	No. of Heaters Per Frame	Total Watts Per Frame
5 VHK 250–26" wide	3	450
HKII 5 & 15 VHK + 27 GHK	4	600
HKII Single High	4	600

*Space heaters on indoor equipment are an optional addition.

Table 10 Standard Control Power Transformers

Single Phase, 60 Hz, 240/120V Secondary, Epoxy – Cast

Primary Voltages	BIL	Available KVA
2400, 4160, 4800	60 KV	3, 5, 10, 15, 25, 37.5, 50, 75
7200, 7620, 8320	95 KV	3, 5, 10, 15, 25, 37.5, 50, 75
12000, 12470, 13200, 13800	95 KV	3, 5, 10, 15, 25, 37.5, 50, 75
12000, 14400	125 KV	3, 5, 10, 15, 25, 37.5, 50, 75

Three Phase, 60 Hz, 208/120V Secondary, Epoxy – Cast

Primary Voltages	BIL	Available KVA
2400, 4160, 4800	60 KV	9, 15, 30, 45, 60, 75, 90, 112.5
7200, 7620, 8320	95 KV	9, 15, 30, 45, 60, 75, 90, 112.5
12000, 12470, 13200, 13800	95 KV	9, 15, 30, 45, 60, 75, 90, 112.5
19920, 24000	125 KV	9, 15, 30, 45, 60, 75, 90, 112.5

Table 11 Standard Voltage Transformers

60 Hz, 120V Secondary, Polyurethane and Epoxy – Cast

Primary Voltages	BIL	Ratios	Metering Accuracy
2400, 4200, 4800	60 KV	20:1, 35:1, 40:1	0.3 W,X,M,Y,Z and 0.6ZZ Burdens at 120 Volts 0.3 W,X,M,Y and 1.2Z at 69.3 Volts
7200, 8400, 12000, 14400	110 KV	60:1, 70:1, 100:1, 120:1	
12000, 14400, 24000	125 KV	100:1, 120:1, 200:1	

1500VA Thermal at 30°C Ambient. 1000VA Thermal at 55°C Ambient.

**Table 12 Type BHK22 Standard Accuracy Current Transformers
Toroidal Type, 5.25" Window, 3.5" Depth**

Single Ratio	Relay Class	Metering Accuracy				
		B0.1	B0.2	B0.5	B0.9	B1.8
50/5	C10	2.4	4.8	—	—	—
75/5	C10	1.2	2.4	4.8	—	—
100/5	C20	1.2	2.4	4.8	—	—
150/5	C20	1.2	1.2	2.4	4.8	—
200/5	C50	0.3	0.3	1.2	1.2	2.4
300/5	C50	0.3	0.3	0.6	1.2	2.4
400/5	C100	0.3	0.3	0.3	0.3	1.2
500/5	C100	0.3	0.3	0.3	0.3	0.6
600/5	C100	0.3	0.3	0.3	0.3	0.6
800/5	C100	0.3	0.3	0.3	0.3	0.6
1000/5	C100	0.3	0.3	0.3	0.3	0.3
1200/5	C200	0.3	0.3	0.3	0.3	0.3
1500/5	C200	0.3	0.3	0.3	0.3	0.3
2000/5	C400	0.3	0.3	0.3	0.3	0.3
2500/5	C400	0.3	0.3	0.3	0.3	0.3
3000/5	C400	0.3	0.3	0.3	0.3	0.3
4000/5	C400	0.3	0.3	0.3	0.3	0.3
5000/5	C400	0.3	0.3	0.3	0.3	0.3

Mounting: One or two per 1200/2000A primary bushing.

**Table 13 Type BHK23 Standard Accuracy Current Transformers
Toroidal Type, 6.50" Window, 3.5" Depth**

Single Ratio	Relay Class	Metering Accuracy				
		B.01	B.02	B.05	B.09	B1.8
1500/5	C200	0.3	0.3	0.3	0.3	0.3
2000/5	C200	0.3	0.3	0.3	0.3	0.3
2500/5	C200	0.3	0.3	0.3	0.3	0.3
3000/5	C200	0.3	0.3	0.3	0.3	0.3
4000/5	C200	0.3	0.3	0.3	0.3	0.3
5000/5	C200	0.3	0.3	0.3	0.3	0.3

Mounting: One or two per 3000A primary bushing.

**Table 14 Type BHK23S High Accuracy Current Transformers
Toroidal Type, 6.5" Window, 7.0" Depth**

Single Ratio	Relay Class	Metering Accuracy				
		B.01	B.02	B.05	B.09	B1.8
1500/5	C400	0.3	0.3	0.3	0.3	0.3
2000/5	C400	0.3	0.3	0.3	0.3	0.3
2500/5	C400	0.3	0.3	0.3	0.3	0.3
3000/5	C400	0.3	0.3	0.3	0.3	0.3
4000/5	C400	0.3	0.3	0.3	0.3	0.3
5000/5	C400	0.3	0.3	0.3	0.3	0.3

Mounting: One per 3000A primary bushing.

**Table 15 Type BHK22M Standard Accuracy Current Transformers
Toroidal Type, 5.25" Window, 3.5" Depth**

Ratio	Tapped Ratio	Relay Class	Metering Accuracy				
			B0.1	B0.2	B0.5	B0.9	B1.8
600/5	50/5	—	—	—	—	—	—
	100/5	C20	2.4	4.8	—	—	—
	150/5	C20	1.2	2.4	2.4	4.8	—
	200/5	C20	0.6	1.2	2.4	2.4	4.8
	250/5	C50	0.6	0.6	1.2	2.4	4.8
	300/5	C50	0.6	0.6	1.2	1.2	2.4
	400/5	C50	0.3	0.3	0.6	1.2	1.2
	450/5	C100	0.3	0.3	0.6	1.2	1.2
	500/5	C100	0.3	0.3	0.6	0.6	1.2
	600/5	C100	0.3	0.3	0.3	0.6	0.6
1200/5	100/5	C20	2.4	2.4	4.8	—	—
	200/5	C20	0.6	1.2	1.2	2.4	2.4
	300/5	C50	0.3	0.6	1.2	1.2	2.4
	400/5	C50	0.3	0.3	0.6	0.6	1.2
	500/5	C100	0.3	0.3	0.3	0.6	1.2
	600/5	C100	0.3	0.3	0.3	0.3	0.6
	800/5	C100	0.3	0.3	0.3	0.3	0.3
	900/5	C100	0.3	0.3	0.3	0.3	0.3
	1000/5	C200	0.3	0.3	0.3	0.3	0.3
	1200/5	C200	0.3	0.3	0.3	0.3	0.3
2000/5	300/5	C50	0.3	0.3	0.6	0.6	2.4
	400/5	C50	0.3	0.3	0.6	0.6	1.2
	500/5	C50	0.3	0.3	0.3	0.6	1.2
	800/5	C100	0.3	0.3	0.3	0.3	0.6
	1000/5	C100	0.3	0.3	0.3	0.3	0.3
	1200/5	C200	0.3	0.3	0.3	0.3	0.3
	1500/5	C200	0.3	0.3	0.3	0.3	0.3
	1600/5	C200	0.3	0.3	0.3	0.3	0.3
	2000/5	C200	0.3	0.3	0.3	0.3	0.3

Mounting: One or two per 1200/2000A primary bushing.

**Table 16 Type BHK22S High Accuracy Current Transformers
Toroidal Type, 5.25" Window, 7.0" Depth**

Single Ratio	Relay Class	Metering Accuracy				
		B0.1	B0.2	B0.5	B0.9	B1.8
50/5	C20	4.8	4.8	—	—	—
75/5	C20	1.2	2.4	4.8	—	—
100/5	C50	0.6	1.2	2.4	4.8	4.8
150/5	C50	0.3	0.6	1.2	1.2	2.4
200/5	C100	0.3	0.6	1.2	1.2	2.4
300/5	C100	0.3	0.3	0.3	0.6	1.2
400/5	C200	0.3	0.3	0.3	0.3	0.6
500/5	C200	0.3	0.3	0.3	0.3	0.3
600/5	C200	0.3	0.3	0.3	0.3	0.3
800/5	C200	0.3	0.3	0.3	0.3	0.3
1000/5	C200	0.3	0.3	0.3	0.3	0.3
1200/5	C400	0.3	0.3	0.3	0.3	0.3
1500/5	C400	0.3	0.3	0.3	0.3	0.3
2000/5	C800	0.3	0.3	0.3	0.3	0.3
2500/5	C800	0.3	0.3	0.3	0.3	0.3
3000/5	C800	0.3	0.3	0.3	0.3	0.3
4000/5	C800	0.3	0.3	0.3	0.3	0.3
5000/5	C800	0.3	0.3	0.3	0.3	0.3

Mounting: One only per 1200/2000A primary bushing.

**MOC/TOC
CONTACT RATING
20A – 600 VAC**
ELECTRICAL
Continuous Rating

24 amperes 600 volts

Interrupting Current

20 amperes 120 volts ac

20 amperes 240 volts ac

20 amperes 600 volts ac

20 amperes 24 volts dc

2½ amperes 125 volts dc

Maximum Breaking Ability

75 amperes

Maximum Making Ability

120 amperes

Momentary Current

420 amperes

1 second

Contact Resistance

30 milliohms

NOTE: Red color denotes information to be supplied by purchaser regarding either:

1. Choice of alternates
2. Addition of optional features
3. Specific information

General

(Indoor-outdoor-outdoor walk-in) metal-clad switchgear described in this specification is intended for use on a (2400-4160-4800-6900-13800-27000) volt 3-phase (3-4) wire

60 Hertz system. The switchgear shall be rated (4160-7200-13800-27000) volt and have horizontal drawout (vacuum-SF₆) power circuit breakers. The switchgear and circuit breaker either individually or as a unit shall have an impulse rating of (60-95-125) kV. The entire switchgear, including power circuit breakers, meters, relays, etc., shall be completely factory tested and breakers of like ratings shall be interchangeable.

Applicable standards

The switchgear equipment covered by these specifications shall be designed, tested and assembled in accordance with the latest applicable standards of ANSI, IEEE and NEMA.

Stationary structure

The switchgear shall consist of () breaker units and () auxiliary units assembled to form a rigid self-supporting completely metal-enclosed structure. Each unit structure shall be segregated by metal-sheets into the following separate compartments:

- (1) Circuit breaker
- (2) Main bus
- (3) Instrument
- (4) Current transformer
- (5) Auxiliary
- (6) Cable or bus duct connection

Circuit breaker compartment

Each circuit breaker compartment shall be designed to house a horizon-

tal drawout (4160-7200-13800-27000) volt (vacuum-SF₆) power circuit breaker. The stationary primary disconnecting contacts shall be constructed of silver-plated copper. All movable contact fingers and springs shall be mounted on the circuit breaker where they may easily be inspected. The entrance to the stationary primary disconnecting devices shall be automatically covered by a grounded metal safety shutter when the circuit breaker is in the test position, disconnected position, withdraw position or removed from the switchgear.

Cable compartment

The lower primary disconnecting contacts shall be supported by means of flame-retardant, track-resistant polyester glass or optional porcelain bushings which extend into the cable compartment. (Mechanical type cable terminals will be bolted to the outgoing bus by means of an adapter) (_____ potheads suitable for terminating _____ cable will be furnished.) A ground bus shall extend through the length of the switchgear.

Bus compartment

Removable panels shall be provided for access to the bus compartment. The main bus shall be rated (1200-2000-3000) amperes. All bus bars shall be silver-plated, and bolted connections shall be used. The conductors shall be insulated by means of flame-retardant, track-resistant epoxy insulation. Flame-retardant, track-resistant polyester glass (5 & 15KV) or porcelain (5, 15 and 27KV) bus supports shall support the insulated bus.

Doors and panels — indoor

The relays, meters, instruments, control switches, etc. shall be mounted on a formed front hinged panel. The cable compartment shall

have a (bolted removable panel or optional hinged rear door(s)). All surfaces shall be phosphate treated and electrostatically painted with a corrosion resistant polyester powder finish. Color of finish shall be light gray, ANSI #61.

Doors and panels — outdoor

The relays, meters, instruments, control switches, etc. shall be mounted on a formed hinged panel. The panel shall be mounted in a compartment located on the same side of the switchgear as the circuit breaker compartment.

All weatherproof exterior doors shall be provided with suitable fasteners. Cleanable metallic filters shall cover the louvers. All surfaces shall be phosphate treated and electrostatically painted with a corrosion resistant polyester powder finish. The color of the finish coats shall be gray, ANSI #61.

Circuit breakers

The circuit breakers shall be rated (4160-7200-13800-27000) volts, 60 Hertz, having a continuous current rating of (1200-2000-3000) amperes and interrupting rating of (250-350-500-750-1000) MVA. All circuit breakers of equal rating shall be completely interchangeable.

The circuit breaker shall be operated by means of a stored-energy mechanism, which is normally charged by a small universal motor, but which can also be charged by a manual handle for emergency manual closing or test. The mechanism shall be so arranged that the closing speed of the contacts is independent of both control voltage and of the operator.

The circuit breaker shall have three independent (vacuum-SF₆) interrupters.

The circuit breaker shall be equipped with secondary disconnecting contacts which shall automatically engage in the operating and test position to complete circuits as required. The contacts shall automatically disengage when the circuit breaker is withdrawn to the disconnected position.

The circuit breaker shall have a means for racking in and out of the compartment and between positions. It shall furthermore be provided with a means for holding the circuit breaker in the compartment in all positions.

Mechanical interlocks shall prevent racking a closed circuit breaker to or from any position. As an optional feature, it shall be possible to padlock the circuit breaker in either the disconnect or the test position. An additional interlock shall be provided which shall assure automatic discharging of the closing springs upon racking of the breaker between disconnected and withdraw positions.

The circuit breaker shall be equipped with means for manually closing and manually opening the contacts and also to close the contacts slowly for testing purposes.

The circuit breaker control voltage shall be: (48–125–250 d-c; 115–230 a-c, 60 Hertz) volts. (For 48 v d-c application, battery should be mounted in the switchboard.)

Instrument transformers

Current transformers — The current transformers shall have ratios as indicated in the details of each switchgear unit. The transformers shall have mechanical rating equal to the momentary rating of the circuit breakers. The current transformers shall be compatible with the full voltage rating of the switchgear. Relay and metering accuracy shall be as indicated on the details for each switchgear unit. Means shall be provided in the switchgear for conveniently shorting the secondary winding.

Potential transformers — The potential transformers shall be of the drawout type, equipped with current limiting primary fuses. They shall have an accuracy as required by the details of each switchgear unit. The ratio shall also be as indicated on the single line diagram.

Control Wiring

Switchgear wire shall be #14 AWG, extra flexible, except where larger is required. The switchgear shall be provided with terminal blocks for outgoing control connections. All wiring shall be terminated in looped tongue type lugs.

Drawings

Promptly upon award of the contract, the manufacturer shall furnish drawings for (approval — record) showing the General Arrangement and Schematic Diagrams. These drawings shall supply all installation and coordination data required by Purchaser for the preparation of electrical and mechanical details necessary to the installation of the switchgear by Purchaser.

Inspection

The completed switchgear shall be available for Purchaser's inspection at the manufacturer's plant before shipment, if specified. The manufacturer shall submit satisfactory test data to the Purchaser, if required, to prove operation and performance of the switchgear in accordance with the specifications.

All testing to be per ANSI C37 standards.

BREAKER AND SWITCHGEAR WEIGHTS



Breaker and Switchgear Weights in Lbs.

Switchgear Enclosure Per Frame (Breaker or Auxiliary) (Does not include Breaker)

Breaker Type	Amp. Rating	Breaker Element	Indoor*	Switchgear Enclosure Per Frame		
				Non Walk-In	Single Row Walk-In	Double Row Walk-In
5 VHK 250	1200	400	1400	1775	2233	3803
	2000	430	1400	1775	2233	3803
	Add Per Line-Up for End Panels			606	1687	2330
5 VHK 350	1200	810	2170 (1736)	2545	3000	4570
	2000	820	2170 (1736)	2545	3000	4570
	3000	930	2170 (1736)	2545	3000	4570
Add Per Line-Up for End Panels			895	1972	2778	
7.5 VHK 500	1200	620	2170 (1736)	2545	3000	4570
	2000	630	2170 (1736)	2545	3000	4570
	3000	930	2170 (1736)	2545	3000	4570
Add Per Line-Up for End Panels			895	1972	2778	
15 VHK 500 (15 GHK 500)	1200	500 (625)	2170 (1736)	2545	3000	4570
	2000	575 (675)	2170 (1736)	2545	3000	4570
	3000	950	2170 (1736)	2545	3000	4570
15 VHK 750 (15 GHK 750)	1200	600 (625)	2170 (1736)	2545	3000	4570
	2000	630 (675)	2170 (1736)	2545	3000	4570
	3000	950	2170 (1736)	2545	3000	4570
15 VHK 1000	1200	825	2170 (1736)	2545	3000	4570
	2000	835	2170 (1736)	2545	3000	4570
	3000	940	2170 (1736)	2545	3000	4570
Add Per Line-Up for End Panels			895	1972	2778	
27 GHK 500	1200	625	2220	2595	3050	4620
	2000	675	2220	2595	3050	4620
27 GHK 750	1200	625	2220	2595	3050	4620
	2000	675	2220	2595	3050	4620
27 GHK 1000	1200	625	2220	2595	3050	4620
	2000	675	2220	2595	3050	4620
Add Per Line-Up for End Panels			895	1972	2778	

5 HK — Potential transformer drawout unit with 3 PT's — 216 lbs. Deduct 32 lbs. for each PT not required.

15 HK — Potential transformer drawout unit with 3 PT's — 515 lbs. Deduct 85 lbs. for each PT not required.

5 & 15 KV — Stationary mounted control power transformers to 15 KVA — 305 lbs.

5 HK — Drawout fuse unit — 160 lbs. } For CPT's larger than 15 KVA single phase.
15 HK — Drawout fuse unit — 295 lbs. }

Breaker Impact Loading — twice the breaker weight (vertical loading); Switchgear impact loading — switchgear weight.

*72" One-High Construction available in indoor construction only.

Weights are shown ().

ABB Power Distribution, Inc.
201 Hickman Drive
Sanford, FL 32771