



**SWITCHGEAR**

# **INSTRUCTIONS**

---

**TYPES MA-75C, MA-250C and MA-350C, 5-KV  
AIR MAGNETIC CIRCUIT BREAKERS**

**with**

**STORED ENERGY OPERATORS**

**NO. 515-1**

---

18X5165  
February 1974

# CORRECTION SHEET

This sheet(s) notes changes which should be made in the attached instruction booklet:

CIRCUIT BREAKER INSTRUCTIONS 18X5165

Types MA-75C1, MA-250C1 and MA-350C1, 5-KV  
Air Magnetic Circuit Breakers  
with  
Stored Energy Operator  
NO. 515-1

ON PAGE 13, Procedure D title should read:

Procedure D. "Breaker Open Position"

Paragraph should read as follows:

Dimension "d" (Breaker Open illustration of Fig. 10) is measured between the disconnect arm and the bottom of the second finger in the main contact assembly. The open position is determined by the setting of the rod end (40, Fig. 2) at the top of the puffer piston rod. The rod end (if set too low) can effect the trip latch roller clearance (Fig. 11). The optimum setting is to obtain the maximum open contact gap "d" while maintaining the specified trip latch roller clearance (see trip latch adjustment page 14). A dimension "d" of less than 3-11/16 in. indicated improper adjustment.

---

These instructions do not purport to cover all details or variations in equipment nor to provide for every possible contingency to be met in connection with installation, operation or maintenance.

---



SWITCHGEAR

INDEX

INTRODUCTION .....	1	Tilting Arc Chutes .....	11
Warranty .....	1	Barrier Stacks .....	11
Receiving .....	1	Servicing Disconnect Arms .....	12
Storage .....	1	Contact Pressure of Hinge Joint .....	12
Circuit Breaker Preparation .....	1	Arcing Contact Hinge Joint .....	12
DESCRIPTION .....	3	Contact Alignment .....	12
Arc Interruption .....	3	Auxiliary Switch .....	14
Operators .....	3	Interlock Plunger .....	14
Stored Energy Operator .....	3	Trip Latch Adjustments .....	14
Trip Latch Check Switch .....	3	Manual Charging of Closing Springs .....	15
Auxiliary Equipment .....	4	Maintain a Firm Grip on Crank .....	15
Auxiliary Switch .....	4	Maintenance Slow Close .....	15
Capacitor Trip Device .....	4	Maintain a Firm Grip on Crank .....	15
Arc Chute Assembly .....	4	Removal of Spring Blocking Device .....	15
Circuit Breakers .....	5	Removal of Power Springs .....	16
DESCRIPTION OF OPERATION .....	6	Motor Cutoff Switch .....	16
Spring Charging Cycle .....	6	Motor Cutoff Switch Adjustment .....	16
Trip Latch Check Switch .....	6	Spring Release Latch Bite Adjustment .....	17
Breaker Closing Cycle .....	7	Spring Release Latch Check Switch Adjustment .....	17
Spring Recharge After Closing .....	7	Free Height Adjustment .....	17
Tripping Cycle .....	7	Trip Adjustment .....	17
Stored Energy Operator – Components Nomenclature .....	8	Overtravel .....	17
Stored Energy Operator .....	9	Closing Latch Mechanical Interlock .....	17
Closing Circuit .....	9	MAINTENANCE .....	19
Spring Release Latch – Mechanical and Electrical .....	9	General .....	19
Interlocks .....	9	Mechanism – Stored Energy Operator .....	19
ADJUSTMENTS .....	11	Closing Spring Removal .....	19
Circuit Breaker Timing .....	11	Lubrication .....	20
Phase Barrier Assembly .....	11	Method for Cleaning Bearings .....	20
ILLUSTRATIONS .....		Air Puffers .....	20
Fig. 1 Circuit Breaker Handling Instructions .....	22	Fig. 11 Trip Latch Clearance Adjustment .....	32
Fig. 2 Typical Circuit Breaker Assemblies .....	23	Fig. 12 Trip Latch Bite and Check Switch Adjustments .....	33
Fig. 3 Description of Operation .....	24	Fig. 13 Maintenance Close Spring Blocking Device Insertion .....	34
Fig. 4 Breaker Contacts .....	25	Fig. 14 Motor Cutoff Switch .....	35
Fig. 5 Type Q-10 Auxiliary Switch .....	26	Fig. 15 Spring Release Latch Bite and Check Switch Adjustments .....	36
Fig. 6 Arc Chutes .....	27	Fig. 16 Closing Spring Dump Mechanism .....	37
Fig. 7 Description of Operation .....	28	Fig. 17 Spring Release Latch Mechanical Interlock .....	38
Fig. 8 Description of Operation .....	29	Fig. 18 Frame and Operator, Drive Assembly and .....	
Fig. 9 Control Scheme for Stored Energy Operator .....	30	Linkage Assembly Lubrication .....	39
Fig. 10 Stud and Support Assembly .....	31	Fig. 19 Lubrication Points on Breaker .....	40
		Fig. 20 Lubrication Chart .....	41

www.ElectricalPartManuals.com

## INTRODUCTION

This instruction manual contains installation, operation and maintenance information for Types MA-75C, MA-250C and MA-350C stored energy operated, 5-kv air magnetic circuit breakers.

### WARRANTY

The sales contract carries all information on warranty coverage.

### RECEIVING

Circuit breakers are shipped from the factory completely assembled. Observe weight markings on crates and ensure that capable handling equipment is used.

Remove crating carefully with the correct tools. Check each item with the shipping manifest. If any shortage or damage is found, immediately call it to the attention of the local freight agent handling the shipment. Proper notation should be made by him on the freight bill. This prevents any controversy when claim is made and facilitates adjustment.

When handling breaker (Fig. 1) with a crane or hoist, hooks should be attached only to breaker frame. Use a spreader to prevent frame distortion and/or damage to arc chutes. Do not attach lifting hooks, rope, etc., to bushings, insulating parts, fittings, etc. Do not slide breaker off shipping skid without using ramp blocks (T-Shaped pieces) provided as interlock plunger and linkage may be damaged.

### STORAGE

Indoor - The circuit breaker should be installed as soon as possible. If storage is necessary, it should be kept in a clean dry place where it will not be exposed to dirt, corrosive atmospheres or mechanical abuse.

Outdoor - Outdoor storage of circuit breakers is not recommended. If breakers must be stored outdoors, they must be covered completely and a heat source provided to prevent condensation and subsequent corrosion.

### CIRCUIT BREAKER PREPARATION

Prepare the circuit breaker for insertion into its cubicle as follows:

1. Remove Packaging. Note: Breakers are shipped in closed position with the trip rod and foot lever enclosed by packaging to prevent opening during shipment.
2. Push manual trip rod to open breaker.
3. Remove phase barriers and unfasten both front and rear blowout coil connections. (See "Phase Barrier Assembly", page 11.)

4. With arc chute support in place at the rear of the breaker, tilt the arc chutes (refer to page 11 for details) to expose contact area.
  5. Remove dust, foreign particles, etc., from breaker.
    - 5A. Inspect ceramics for possible shipping damage.
  6. Check for mechanical freedom of disconnect arm movements by slowly closing the breaker. Reference page 15 for Close Slow Procedure.
  7. Trip breaker by depressing trip rod, Fig. 2, Item 43.
  8. Return arc chutes to upright position, fasten both front and rear blowout coil connections and replace phase barriers. Be sure screws on all phases are tightened securely.
  9. Install plug jumper and energize control. (Springs should charge.)
  10. Close breaker
  11. Trip breaker
- } with control switch on cubicle panel.
12. Depress foot lever and close electrically (\*).
  13. Release foot lever and repeat steps 10 (#) and 11.
  14. De-energize control power and remove plug jumper.
  15. Coat movable primary and secondary disconnects with a light film of A-C contact lubricant, 15-171-370-002.
  16. Insert breaker into its cubicle to "disconnect" position and close manually (\*).
  17. Complete movement of breaker to "test" position and repeat steps (10 (#) and 11.
  18. Check for proper alignment between stationary and movable secondary contacts. Check for proper alignment between aux. switch bayonet on cubicle wall and operating fork on breaker.
  19. With line and bus de-energized, rack breaker into fully connected position. Close and trip breaker from main control panel. If bus or line are energized, get clearance before beginning this step.
  20. Lock out Kirk interlock (if provided) and repeat step 10 (\*).
  21. Open interlock and repeat steps 10 (#) and 11.
  22. Breaker is now ready for normal operation.

(\* ) Breaker is trip free.

(#) Breaker will close.

## DESCRIPTION

A typical circuit breaker consists of primary disconnect, arc chute, and operator sections. The primary disconnect section contains the main contacts, which supply power to the load. The arc chute section dissipates the power arc drawn during the opening of the main contacts. The operator section contains the mechanism used to close and open the main contacts. This mechanism consists of a stored energy operator with its associated control circuitry.

### ARC INTERRUPTION

Arc interruption is accomplished in free air at atmospheric pressure with the aid of a self-induced, magnetic blowout field and forced air draft. When the trip solenoid is energized, load current is being carried by the main contacts. As the contacts open, the main contacts part first and the current is transferred to the arcing contacts. When the arcing contacts part, an arc is established between them.

The arc between the arcing contacts is transferred to the arc runners as the arcing contacts open. The transfer of the arc to the arc runner establishes full current flow through the blowout coils, setting up a strong magnetic field. The magnetic field, accompanied by the natural thermal effects of the heated arc, tends to force the arc upward into the barrier stack. The cool surfaces of the barrier stack cool and de-ionize the arc, while the V-shaped slots in the stack reduce its cross-section and elongate it, leading to rapid extinction. The arc runners are made of wide, heavy material for maximum heat dissipation and for minimum metal vaporization.

A puffer mechanism provides a forced air draft through the main contact area. This aids the magnetic blowout field and natural thermal effects in forcing the arc into the barrier stack for easy extinction.

### OPERATORS

The breaker is closed by the operator straightening a toggle in the four-bar linkage (Fig. 7, Item 12). The operator is powered by precharged springs (stored energy).

#### Stored Energy Operator

The stored energy operator (Fig. 3) uses charged springs to power the closing operation. Opening is spring-powered also, but not with the same springs used for closing. A stored energy operator consists of three systems: spring charging drive, cam and ratchet assembly, and the four bar toggle linkage (Fig. 4, A - D). These systems are disengaged from each other except while performing their specific functions. For example - the spring charging drive and cam-ratchet assembly are disengaged except when the cam-ratchet arrangement is being charged. Similarly, the cam-ratchet and four bar linkage are free of each other except during closing.

Stored energy operated breakers normally require a single commercial relay for control. This relay is furnished to match the control voltage.

#### Trip Latch Check Switch

The trip latch check switch is supplied with breakers intended for instantaneous reclosing duty. The switch monitors the position of the trip latch, and will function to prevent the breaker from closing electrically until the trip latch is reset.

## AUXILIARY EQUIPMENT

### Auxiliary Switch

Mounted on the breaker, the auxiliary switch is normally used to open the trip circuit when the circuit breaker is opened. As this multi-stage switch operates from the breaker disconnect blades, circuitry dependent on the position of the breaker, such as indicator lights, etc., is wired through this switch. The individual stages are easily converted to "a" or "b" without disassembling the switch (Figure 5).

### Capacitor Trip Device

A capacitor trip device is commonly used with circuit breakers having an ac control supply installed in remote locations of unattended substations where battery cost and maintenance are undesirable.

In these cases, the capacitor trip device may be charged from the same stepdown transformer that is used to energize the breaker control. This stepdown transformer should be connected to the line side of the breaker.

To apply the capacitor trip device to existing breakers originally shipped with dc trip coils, contact your Allis-Chalmers sales representative.

## ARC CHUTE ASSEMBLY

Each arc chute (Fig. 6) consists of a frame retardant envelope which provides phase isolation for interruption and venting of the by-product gases of interruption. The arc chute contains -

1. The stationary end arc runner (4) and moving end arc runner (3) to which the arc terminals transfer from the arcing contacts. The arc runners form paths for the arc terminals to travel up the arc chute.
2. The stationary end blowout coil (15) and moving end blowout coil (13) which connect their respective arc runners to the top and bottom bushings. The current in these coils creates the magnetic flux which passes through cores (18), pole pieces (22) and the space between the pole pieces. The action of this flux on the arc forces the arc up the barrier stack.
3. The barrier stack (23) consisting of a number of refractory plates, with "V-shaped" slots, cemented together. The barrier stack cools, squeezes and stretches the arc to force a quick interruption.
4. The barrier (1) containing coolers (28) through which the by-product gases of interruption pass, completes the cooling and deionizing of the arc products.

Arc chutes are tilted to expose contact area for inspection of barrier stack (23). The arc chutes may also be lifted and removed from the breaker. Unfasten front and rear coil connections before tilting or removing arc chutes.

## OPERATION

### CIRCUIT BREAKERS

Normal -- Normal circuit breaker operation is controlled by cubicle mounted controls or other control devices. The closing springs of stored energy operated breakers will charge as soon as the breaker control bus is energized. Check the motor cutoff adjustment (page 36) if springs do not charge.

Opening Breaker -- Stored energy operated breakers can be tripped manually by depressing the trip rod (43), Fig. 2, or electrically by energizing the trip circuit. This rotates the latch that allows the closing linkage to collapse and reset.

Closing Breaker -- When the springs of a stored energy operated breaker are fully charged, it can be closed by pulling the manual close pull rod (21), Fig. 7, or electrically by energizing the closing circuit. This rotates the latch that allows the springs to close the breaker.

## DESCRIPTION OF OPERATION

### SPRING CHARGING CYCLE

Energization of the Breaker Control Circuit will cause the spring charging motor (1, Fig. 7), to start charging the closing springs (6, Fig. 3). The spring charging motor (1) will drive the driving pawl (2, Fig. 3), through an eccentric drive shaft (3, Fig. 3). The driving pawl (2) will turn the ratchet wheel (4, Fig. 3), counter-clockwise one tooth at a time. The holding pawl (5, Fig. 3) will hold the ratchet in position between driving strokes of driving pawl (2). This charging operation will continue turning the ratchet wheel (4) counter-clockwise a tooth at a time until the closing springs (6) are fully charged (dead center). The motor will drive the ratchet wheel past this dead center position and the closing springs (6) will aid rotation driving the ratchet wheel and cams counter-clockwise until spring release rollers (8, Fig. 7), on the inside surfaces of cams (7, Fig. 7), engage the spring release latch (9, Fig. 7). This arrests the motion of the ratchet wheel (4) and the cams (7) and holds the operator in the fully charged position. As the cams and ratchet wheel go over center, the motor cutoff switch (10, Fig. 3), is actuated to de-energize the spring charging motor (1). The spring charging motor then coasts to a stop, driving pawl (2) oscillating in the toothless section of the ratchet wheel.

The motor cutoff switch (10) provides four functions:

1. It de-energizes the spring charging motor (1);
2. It opens a contact in the anti-pump relay circuit;
3. It sets up the closing coil circuit;
4. It can be used to energize an indicating light to indicate that the closing springs (6) are fully charged.

#### NOTE:

A close latch check switch (16, Fig. 3), is in the motor circuit. The close latch check switch monitors the position of the spring release latch (9) and will prevent charging of the closing springs (6) electrically unless the spring release latch (9) is in the correct position.

As the energy is stored in the closing springs, the four bar linkage (12, Fig. 7), will be positioned by the linkage reset spring (11, Fig. 8), which acts to cause cam follower rollers (13, Fig. 3), to follow the surface of cam (7, Fig. 7), until the links are in a reset position, and allowing latch rollers (20, Fig. 3), to be positioned in front of trip latch (18, Fig. 3).

The charged position of the operator is shown in Fig. 7.

### TRIP LATCH CHECK SWITCH

The trip latch check switch (19, Fig. 3), (when furnished) (supplied with breakers applied to instantaneous reclosing duty) monitors the position of the trip latch (18, Fig. 3). This switch is in series with the spring release solenoid and will prevent initiating the closing cycle electrically unless the trip latch (18) is reset.

## BREAKER CLOSING CYCLE

Energizing the spring release solenoid (13, Fig. 7), will drive the spring release latch (9, Fig. 7), away from the spring release rollers (8, Fig. 7), on the cams (7, Fig. 7), releasing the stored energy in the closing springs (6, Fig. 3). The closing springs (6) will drive the ratchet wheel (4, Fig. 3), and the cams (7, Fig. 7), counter-clockwise at a high rate of speed. The cams (7) will engage the cam follower rollers (14, Fig. 3), of the four bar linkage (12, Fig. 7), and drive them forward causing the four bar linkage to become straight. As the four bar linkage (12) becomes straight, it drives the radius arm (15, Fig. 7), upward causing the breaker contacts to close and the opening springs to be charged. The cams (7) drive the four bar linkage (12) over toggle and against the frame thereby latching the breaker contacts in the closed position.

## SPRING RECHARGE AFTER CLOSING

When the closing cycle has been initiated and the cams (7, Fig. 7), begin to turn, the motor cutoff switch (10, Fig. 3), resets itself. A "b" aux. switch of the breaker opens de-energizing the spring release solenoid (13, Fig. 7). The spring release latch (9, Fig. 7), returns to its reset position and the close latch check switch (16, Fig. 3), closes and energizes the spring charging motor (1). The closing springs (6) are then recharged as described earlier.

## TRIPPING CYCLE

Energizing the trip solenoid (17, Fig. 3), will drive the trip latch (18, Fig. 3), away from latch roller (20, Fig. 3), on the four bar linkage (12, Fig. 7). This allows the four bar linkage to collapse and the breaker contacts will open. If the closing springs (6) are in the charged position, the linkage reset spring (11, Fig. 8), will immediately reset the four bar linkage (12). If the closing springs (6) are not charged, the linkage reset spring (11) will not reset the four bar linkage (12) until just before the closing springs (6) are completely charged.

STORED ENERGY OPERATOR-COMPONENTS  
NOMENCLATURE

To be used with "Description of Operation" Figures 3, 7 and 8.

1. Spring Charging Motor
2. Driving Pawl
3. Eccentric Drive Shaft
4. Ratchet Wheel
5. Holding Pawl
6. Closing Springs
7. Cams
8. Spring Release Rollers
9. Spring Release Latch
10. Motor Cutoff Switch
11. Linkage Reset Spring
12. Four Bar Linkage
13. Spring Release Solenoid
14. Cam Follower Rollers (Main Toggle Roll)
15. Radius Arm
16. Close Latch Check Switch
17. Trip Solenoid
18. Trip Latch
19. Trip Latch Check Switch
20. Latch Roller
21. Manual Close Pull Rod
22. Spring Discharge Roller Free Height Adjustment
23. Spring Discharge Close Latch Yoke End Adjustment
24. Spring Discharge Roller
25. Charge-Discharge Indicator
26. Discharge Indication Adjustment
27. Charge Indication Adjustment
28. Mechanical Charging Interlock Adjustment
29. Manual Charging Shaft (515-1 Operator)
30. Anti-Pumping Relay
31. Trip Latch Bite Adjusting Screw
32. Trip Latch Bite Adjusting Locking Nut
33. Close Latch Bite Adjusting Screw
34. Close Latch Bite Adjusting Locking Nut
35. Motor Cutoff Switch Actuator
36. Lower Link Stop
37. Roll Pin Striker
38. Aluminum Spring Drive Blocks

## STORED ENERGY OPERATOR

The normal control for this operator is contained upon a control panel mounted at the rear of the unit. It consists of the motor cutoff switch (10), anti-pumping relay (30), and the close latch check switch (16). The control arrangements elementary diagram is shown in Fig. 9.

The spring charging motor power is supplied through terminals 3 and 4, Fig. 9. The mechanical interlock is a switch operated by the breaker release lever (foot lever) which opens the motor circuit when the lever is depressed. The spring release latch check switch is closed when the spring release latch (9) is in the reset position. The 88 switches are shown with the closing springs discharged. When the control is energized, the motor starts to charge the springs. The 88 switch is operated by a roll pin striker (37) mounted in the ratchet wheel (4, Figs. 3 and 14). As the ratchet wheel and drive blocks charge the springs, the ratchet wheel revolves to the position of full compression, dead center. Beyond dead center position, the springs aid rotation and cause the motor cutoff switch striker to depress the actuator (35) of the 88-1 switch, opening the motor circuit and the 88-3 contact in the anti-pumping relay circuit. At this instant, the spring charging motor coasts to a stop with the driving pawl (2) oscillating freely on the smooth portion of the ratchet wheel.

### Closing Circuit

The standard control circuit for a stored energy operator is shown in Fig. 9. When the close control switch is closed, the circuit from terminal 7 through 88-2 and 52Y1 to 52B through trip latch check switch (19) to terminal 6 energizes the spring release coil, closing the breaker. As soon as the closing springs are discharged, the 88-3 switch contact closing to energize the 52Y relay. If the close control switch remains closed, the 52Y relay remains picked up through contact 52Y2. Control switch has to be released to reset control for another closing operation. This forms the anti-pumping relay circuit which prevents the circuit breaker from reclosing immediately after a trip free operation. If control power is momentarily lost during closing, upon re-energization, the 52Y relay picks up instantaneously through contact 88-3 maintaining the anti-pumping relay circuit prior to complete spring charging.

### Spring Release Latch - Mechanical and Electrical Interlocks

The spring release latch must be fully reset to receive the cam mounted spring release rollers at the end of the charging cycle. To insure the spring release latch is in this fully reset position, an electrical and mechanical interlock is provided.

The spring release latch check switch (16, Fig. 3 and 15) consists of a snap-action type switch mounted in close proximity to the spring release latch. A striker plate at the tail of the spring release latch engages the switch's actuator slightly before the fully reset position is achieved, and actuates the switch prior to the latches reaching the fully reset position. At the time of actuation, a contact closes enabling the charging sequence. The switch operates with very small differential, and this sensitivity coupled with the spring release latch biased engagement of the spring release rollers provides a positive sensitive interlock.

The mechanical interlock (Fig. 17) prevents manual charging of the breaker if the spring release latch is not adequately reset. A linkage attached by a clevis to the spring release latch extends down the side of the breaker frame to the driving pawl mechanism. An extension of the interlocks linkage passes above the driving pawls constant force return spring. If the spring release latch fails to return to a fully reset position, the linkage extension thrusts the driving pawl's return spring downward preventing the driving pawl's engagement of the ratchet wheel, thus mechanically inhibiting either manually or electrical spring charging.

## ADJUSTMENTS

Adjustments are factory set and checked before and after numerous mechanical operations on every breaker to insure correctness. No adjustment checking should be necessary on new breakers. If a malfunction occurs, check for hidden shipping damage.

The following will help you make the correct adjustments when replacing a broken or worn part.

### CIRCUIT BREAKER TIMING

A comparison of circuit breaker timing at any period of maintenance with that taken when the breaker was new will indicate the operational condition of the breaker mechanism. A time variance of more than 1/2 cycle on opening and 2 cycles on closing indicates a maladjustment or friction buildup. A hole in the movable contact arm is provided for connection of a speed analyzer (item 29, Fig. 10).

### PHASE BARRIER ASSEMBLY

Full size barriers of high dielectric flame retardant material isolate each phase (Fig. 2).

To remove phase barriers, lift panel spring assembly (13) out of slots (14) to release panel (32). Lift and remove panel (32). Remove screws (23 and 39) from barrier (22).

Remove screws (2, 48 and 49). Remove rear barrier (25).

### TILTING ARC CHUTES

Remove phase barriers as described under "Phase Barriers," above. Refer to Fig. 2. Remove Allen HD Capscrew (51) and screw (37) on each phase to disconnect blowout coils.

Position arc chute support at the rear of the breaker and tilt back the arc chutes.

After arc chutes are tilted back to their normal position, make sure all screws have been replaced and tightened securely on all phases before phase barriers are replaced.

Note: MAKE SURE THAT BLOW OUT COILS HAVE BEEN RECONNECTED.

### BARRIER STACKS

The barrier stacks (Fig. 6) are fragile and must be handled carefully. Inspect the barrier stacks for erosion of the plates in the areas of the slots. The barrier stacks should be replaced when a milky glaze appears on the full length of the edges of most of the slots. They should also be replaced if plates are broken or cracked. When cleaning the breaker and cubicle, inspect for pieces of barrier stack refractory material which would obviously indicate breakage.

To remove the barrier stacks, tilt back the arc chutes, remove screws (2) and barrier (1) from each arc chute. Slide barrier stack (23) through top of arc chute. When replacing barrier stack be sure the v-shaped slots go in first.

## SERVICING DISCONNECT ARMS

The frequency of contact inspection depends on severity of service. Refer to Fig. 10. Remove disconnect arms as a unit by removing screw (24), nut (14) and spring washer (23). Carefully inspect all contact surface in hinge joint. Silver washer (25) and adjacent surfaces should be clean and free of roughness or galling. Lubricate silver washer and mating surfaces by applying electrical contact grease. Reassemble hinge joint. Tighten screw (24) and nut (14). Spring washer (23) and silver washer (25) must be assembled in their original position to assure proper adjustment. Replace badly pitted or burned contacts before they are damaged to such an extent to cause improper operation of breaker.

## CONTACT PRESSURE OF HINGE JOINT

The hinge joint contact pressure is in proper adjustment when a pull of 4 to 6 pounds is required to move the disconnect toward the open position.

This measurement is obtained as follows: (Fig. 10)

Remove pin (12) and detach link (8) from the disconnect arms (18) and (19). Move the disconnect to a position just short of contact make. Attach a spring scale to the disconnect 8-1/2 inches above screw (24), and in a direction perpendicular to the longest edge of the disconnect arm. Measure the pull to move the disconnect toward the open position after start of motion. Read scale while disconnect is moving through normal opening stroke.

Adjustment is made by tightening (or loosening) nut (14).

Before attaching link (8) to disconnect arms (18 and 19), check contact alignment and contact lead (below and next page).

## ARCING CONTACT HINGE JOINT

The arcing contact hinge joint (Fig. 10) is in proper adjustment when each spring washer (15) is deflected approximately 0.015 inches.

This adjustment is obtained by tightening nut (4) until all parts just touch, then tighten the nut 3/4 to 1 turn more.

## CONTACT ALIGNMENT

The main and arcing contacts are an integral part of the bushing assemblies and are carefully aligned with the upper and lower bushings before shipment. Normally, no further adjustment is necessary.

Use these procedures if it becomes necessary to change contacts or reset contact alignment (refer to Fig. 10).

### Procedure A. Horizontal Alignment

1. Push stationary contact fingers as far back as they will go on stud.

2. Using maintenance closing procedure, move the disconnect towards the closing position until it touches a main contact finger (view A-A, Main Contacts Engaging, Fig. 10). Dimensions "C" should be no greater than .020 with one contact touching.
3. Adjustment is made by loosening two nuts (22) and rotating the entire contact assembly. Check alignment (dimension "C") after nuts (22) are tightened. HOLD ARM  
TAKE UP NUT
4. Alignment is checked and adjusted on each phase separately. Be sure there are no binds between contacts (11) that could prevent wiping action with the disconnect arm.

#### Procedure B. Contact Penetration (Stroke)

1. Contact penetration should be checked and adjusted only when the contacts are properly aligned.
2. Check that open gap "d" is approximately correct to avoid over penetration (see Procedure D).
3. Using power\* closing procedures, close and latch breaker. The spread of the contacts (view "A-A", Breaker Latched) should be 1/8 to 3/16 inch. This is the total of the two gap dimensions "a" measured on each side of the contact centering tube between the brass tube and the flat stop surface on the contact. Each "a" dimension is normally 1/16 to 3/32 inch.
4. With the breaker open, adjust by increasing or decreasing length of link (8) by turning nut (16). Adjust each phase separately.

#### Procedure C. Arcing Contact Lead

Arcing contacts are adjusted only after the main contacts have the proper alignment and penetration. The arcing contacts should make before the main contacts. To measure and adjust each phase:

1. Push stationary contacts back on stud.
2. Using the maintenance closing procedure, slowly move all three phases toward the closed position until a dimension between 7/32 to 9/32 (dimension "b" view "A-A", Arcing Contacts Engaging) can be measured simultaneously between main contacts on all three phases. 1/4" Go  
5/16" No Go
3. Set the arcing contacts to touch simultaneously at this point by adjusting nut (1) on the individual phases.

#### Procedure D. Check Breaker Open Position

Dimension "d" (Breaker Open illustration of Fig. 10) is 3-13/16 inches plus or minus 1/8. 3 11/16  
3 5/16  
Following the setting and adjustment of the contacts (Procedures A, B and C) open the breaker and measure dimension "d" between the disconnect arm and the bottom of the second finger in the main contact assembly. Adjustment is made with the breaker in the open position by positioning rod end (40, Fig. 2) at the top of the puffer piston rod.

\* Power close stored energy operator

## AUXILIARY SWITCH

The type Q-10 auxiliary switch has been tested and adjusted at the factory. Contacts used in the breaker control circuit should not require further adjustment.

The switch (Fig. 5) is designed so that the individual contacts may be repositioned in fifteen degree steps without disassembling the switch.

Using long-nosed pliers, move the rotor contact (16) in the slot of the shell (14), compressing spring (15). This will free the rotor from the retainer (17). Rotate the rotor to the desired position and release. Be sure the rotor springs solidly back against the retainer to fully engage the rotor and retainer teeth.

## INTERLOCK PLUNGER

The foot lever breaker release (20, Fig. 2) operates the interlock plunger (18, Fig. 2) as well as the trip latch. Depressing the lever trips the breaker and raises the plunger. This frees the breaker so that it can be moved in its cubicle. The interlock system is in proper adjustment when the plunger is positioned 1-11/16 to 1-13/16 inch above the floor line, and causes tripping of breaker contacts when it is raised to a level not more than 2-1/16 inch above the floor line. The latch tripping rod associated with the foot lever should be clear of the trip latch by 1/32 to 1/16 inch in the relaxed position (18, Fig. 3).

The foot lever can be padlocked by matching holes in the breaker frame with those in the lever arm. In the padlocked position, the foot lever will be halfway down; the breaker will be trip-free; the interlock plunger will be between 2 and 2-1/4 inches from the floor line and will hold the breaker in any of the three positions within the cubicle.

## TRIP LATCH ADJUSTMENTS

Trip Latch Clearance Adjustment (Fig. 11) - this adjustment is to be performed after completing the arcing contact touch and main contact penetration adjustments referenced above.

This adjustment is necessary to insure proper clearance between the trip latch and trip latch rollers. The puffer (or snubber) height adjustment (Fig. 11) will accomplish this purpose, and in no way will affect the penetration adjustment.

Loosen Lower Link Stop and rotate to permit maximum Lower Trip Link movement. Adjust puffer (or snubber) height to rotate radius arm and four bar linkage until a .030 to .060 gap appears between the trip latch and latch roller. Lock in place. Rotate Lower Link Stop until it touches lower link and lock in place. Recheck dimension "d" as described in procedure D, page 13.

Trip Latch Bite Adjustment - trip latch bite is established by setting the latch tails top surface 5/16 below surface of self clinching nut as shown in Fig. 12a. Lock securely with jam nut. One turn of adjusting screw will alter the gap 0.062 inches. This adjustment should produce 0.259 to 0.111 inches of latch bite as shown in Fig. 12c.

Trip latch check switch setting, (optional item) Fig. 12b - This adjustment is to be completed only after establishing the bite adjustment.

Advance threaded bushing through tapped shelf hole until latch operator just touches upper surface of latch tail. Continue to advance threaded bushing until the trip latch check switch operates (clicks). Apply one additional full turn, and lock switch in position with jam nut. Switch body should be positioned as shown in Fig. 12b. As the latch is rotated, a click should be heard from the switch within the range of latch rotation from fully closed to .090 inches from fully closed.

#### MANUAL CHARGING OF CLOSING SPRINGS

To charge the closing springs manually, disconnect control power before inserting the manual charging crank in the socket at the lower left-hand corner of the breaker. Turn the crank in a counter-clockwise direction to charge the springs. The effort to charge the closing springs will fluctuate and will increase to a peak and then decrease. At the point of least effort an audible click will be heard and the effort to turn the crank will drop to near zero. The mechanism is now fully charged. The breaker may be closed by pulling the manual close pull rod.

#### CAUTION!!

##### MAINTAIN A FIRM GRIP ON CRANK

The closing springs are charged through the driving pawl and ratchet wheel and are thereby indexed by the holding pawl. Some springback can occur between tooth positions on the ratchet wheel.

#### MAINTENANCE SLOW CLOSE

With the breaker removed from the cubicle, manually charge the closing springs as previously described and remove charging handle. Then, from the rear or stud side of the breaker, attach the spring blocking device, Fig. 13, by fastening it in the slots in the closing spring tubes.

Stay clear of the breaker contacts and pull the manual close pull rod at the front of the breaker. This will discharge the closing springs against the spring blocking device during which the breaker contacts will move slightly toward the closed position.

Place the manual spring charging crank back in the socket at the lower left corner of the breaker. By turning the crank counter-clockwise the breaker contacts may be slowly closed for checking contact alignment.

#### CAUTION

##### MAINTAIN A FIRM GRIP ON CRANK

As the contacts will close in increments predicated by the teeth on the ratchet wheel, springback will occur between teeth positions.

#### REMOVAL OF SPRING BLOCKING DEVICE

To remove the closing spring blocking device, Fig. 13, the closing spring must be fully charged. The spring may be charged manually by inserting the charging crank and continuing counter-clockwise rotation. The main contacts will go fully closed as the four bar linkage toggles. Upon continued rotation, the closing springs will be picked-up as noted by increased effort in

cranking. Continue rotation until the springs are fully charged. A sharp click will be heard as the spring release rollers engage the spring release latch indicating full spring charge has been achieved. The spring blocking device may now be easily removed by pulling the blocking portion from the slots in the spring tubes.

#### REMOVAL OF POWER SPRINGS

The removal of closing springs will be necessary in order to permit general overhaul of the breaker. These springs may be removed as follows:

1. Charge breaker utilizing manual charging crank.
2. Install the maintenance close spring blocking device 18-723-721-501. Stand clear of movable main contacts and pull the manual close pull rod.
3. Using a 3/8 hexagon key with a 7/8 open end back up wrench remove four 1/2 - 13 bolts clamping the aluminum bearing block to the mechanism frame.
4. Withdraw the bearing block tie bar, springs, spring retainer tubes, and spring blocking device from the breaker as an assembly.

CAUTION: Handle this assembly carefully - do not throw or drop.

5. If the charging ratchet and cams are to be revolved with springs removed, it is advisable to remove two aluminum spring drive blocks (item 38, Fig. 8) secured to the ratchet and cam crankpins by retaining rings. These pins if not removed or held essentially in a horizontal position may jam while revolving the cam and ratchet assembly.

Motor Cutoff Switch - The 88 motor control switch assembly (Fig. 14) is factory adjusted. If it should become inoperative, entire unit must be removed and inspected for contact wear. Replacement may be necessary.

Motor Cutoff Switch Adjustment - This adjustment is most conveniently performed before installing the charging springs.

Advance ratchet and cam assemblies to position shown (Fig. 14). The back up pawl must occupy the ninth (9) tooth position on the ratchet as counted counter-clockwise from "area" on ratchet periphery which lacks two teeth.

With ratchet in the position described above, adjust the motor cutoff switch vertically until its actuator makes positive contact with the "rollpin striker". Lock switch assembly in this position.

Check lateral movement of actuator. Lateral play at end of actuator (tip) should be no more than 1/16" max. If adjustment is necessary, snug pivot screw to just bind actuator, and then back off 1/16 to 1/8 turn. Rotate ratchet and cam assembly to insure actuator rides in gap between ratchet and cam without striking or binding.

Spring Release Latch Bite Adjustment - free jam nut and place latch in horizontal position (Fig. 15). Visual accuracy. Measure "D" directly above latch pivot. Reproduce this dimension plus 0.062" at the latch face as shown in the figure above by rotating the adjustment screw. Secure jam nut. This adjustment should produce a latch bite of 0.151 to 0.216 inches.

Spring Release Latch Check Switch Adjustment (Fig. 15) - This adjustment is to be performed only after completing the latch bite adjustment described above.

A clearly audible "click" should be heard from the switch with latch spaced 1/32" from latch adjustment screw. The latch switch actuator may be bent slightly to obtain switch operation at this point. Maximum permissible bend is 1/8" as shown.

If switch actuator is bent, observe latch fully closed against adjusting screw and make certain the switch actuator has not contacted the switch body. A 1/64" clearance should exist as shown above.

Free Height Adjustment (Fig. 16) - is achieved by blocking the actuating roller to the indicated height and adjusting a pair of jam nuts, located on the manual closing pull rod, to maintain the roller in this position with blocking removed. Return spring adjusting nut should be set to produce  $0.5 \pm .06$  inch deflection in return spring.

The following adjustments are to be made only after completing the spring release latch bite adjustment described on the previous page and after adjusting connecting link as shown on Fig. 16.

Trip adjustment (Fig. 16) is made by varying the penetration of the "curved actuating rod" in its attachment clevis. A 1/4" (.250) drill is placed between the upper latch surface and the latch adjusting bolt. A 2.906" block is to be inserted between the actuating roller and floor. The "curved" rods upper yoke is nested against a forward roll pin in the closing latch and the lower clevis is adjusted to insure the closing latch will not move when the 1/4" (.250) drill is removed more than 1/16 (.062) inches as measured between adjusting screw and latch surface.

Overtravel (Fig. 16) - no adjustment required. Check with 3.125" blocking below actuating roller. Closing solenoid link should provide freedom of latch movement without jamming.

Spring Release Latch Mechanical Interlock - this adjustment is to be undertaken only after completing the spring release latch bite adjustment described above, Fig. 15.

Adjust actuator rod displacement from support angle to  $1.06 \pm .015$  inches. See detail of adjusting nut "A" (Fig. 17).

Insert a 1/4 (.250) drill between upper surface of close latch and latch adjustment screw.

Check guide bushings to insure they stand off the frame 1/4" as shown.

Free Nut "B" below attachment clevis, and adjust Nuts "B" and "C" to depress pawl return spring and pawl until 1/16 to 3/32 clearance is obtained between tip of pawl and ratchet teeth. This clearance is measured during the clockwise rotation of the pawl as its tip advanced toward the ratchet (power stroke).

The pawl must be rotated using a 1/2" square insert in the eccentric drive shaft or by low voltage (slow rotation) of drive motor or manual charging.

Return the jam nut "C" attachment clevis to bottom on bracket, and tighten external jam nut "B" securely. MAINTAIN CLEVIS PARALLEL TO FRAME.

Remove 1/4 (.250) drill, restoring latch to its normal position. Again rotate eccentric drive shaft. The tip of the drive pawl should engage the full face of each ratchet tooth with a clearance of .030 between the base of the tooth and the engaged tip of the drive pawl.

## MAINTENANCE

Stored Energy Operators Type 515-1, 515-2 and 515-3.

### General

Thorough, periodic inspection is important to satisfactory operation. Inspection and maintenance frequency depends on installation, site, weather and atmospheric conditions, experience of operating personnel and special operation requirements. Because of this, a well-planned and effective maintenance program depends largely on experience and practice.

Prior to performing any maintenance work, make certain all control circuits are open, and that the breaker has been completely withdrawn from the metal-clad unit.

### CAUTION

DO NOT WORK ON THE BREAKER OR OPERATING MECHANISM WHILE THE BREAKER IS IN THE CLOSED POSITION. DO NOT WORK ON THE BREAKER OR OPERATOR WHILE THE CLOSING SPRINGS ARE CHARGED.

Always inspect a breaker which has interrupted heavy fault current.

All current carrying joints should be inspected to be sure all contact surfaces are free of protrusions or sharp plane changes.

### Mechanism - Stored Energy Operator

The circuit breaker mechanism should be inspected at 2000 operation intervals (1000 operation intervals for the MA-350 breaker). This inspection should check for loose hardware and any broken parts. The control wiring should be checked for loose connections and frayed or damaged insulation. The "spring release latch check switch", "trip latch check switch" (if possible), and "mechanical interlock" switch should be checked for mounting tightness. The satisfactory operation of each switch element should be assured with a continuity meter and manual manipulation of the switching element, and adjusted if necessary.

After 10,000 operation, (5000 operations for the MA-350), the operating mechanism should be given a general overhaul and all worn parts replaced. Excessive wear will usually be indicated when adjustments can no longer be satisfactorily made. The general overhaul will require disassembly of the operating mechanism. All bearings and surfaces receiving wear should be examined carefully and re-lubricated in accordance with lubrication instructions which follow.

### Closing Spring Removal

The removal of closing springs will be necessary in order to permit general overhaul of the breaker. These springs may be removed as follows:

1. Charge breaker utilizing manual charging crank.
2. Install the maintenance close spring blocking device (Fig. 13). Stand clear of movable main contacts and pull the manual close pull rod.

3. Using a 3/8" hexagon key with a 7/8 open end back up wrench remove four 1/2 - 13 bolts clamping the aluminum bearing block to the mechanism frame.
4. Withdraw the bearing block tie bar, springs, spring retainer tubes, and spring blocking device from the breaker as an assembly.  
CAUTION: Handle this assembly carefully - do not throw or drop.
5. If the charging ratchet and cams are to be revolved with springs removed, it is advisable to remove two aluminum springs drive blocks secured to the ratchet and cam crankpins by retaining rings. These pins if not removed or held essentially in a horizontal position may jam while revolving the cam and ratchet assembly.

### Lubrication

NOTE: The lubricant supplied with the accessories is intended to be used exclusively on the contacts and must not be used on any part of the circuit breaker mechanism.

Recommended circuit breaker lubrication points are shown in Fig. 18, A, B and C. The chart (Fig. 19) below outlines two methods of lubrication, refer to this chart for recommended lubricant and points of application. The first method requires no disassembly and is suggested for the prevention of problems which could be created by severe environmental or operating conditions.

The second method follows procedure similar to that performed on the breaker at the factory. Follow this procedure only in case of a general overhaul or disassembly.

### Method for Cleaning Bearings

Needle and roller bearings are factory lubricated for life and should not require attention. However, the best of greases are affected by time and atmospheric conditions and may require service.

To lubricate these bearings when parts are disassembled, the following procedure is recommended. Clean in solvent, wash in alcohol, spin in light machine oil, drain and repack with Beacon P-325 grease.

DO NOT REMOVE NEEDLE BEARINGS FROM  
THE RETAINING PART

### Air Puffers

Air puffers (E, Fig. 18, A) are important to the interruption process because they provide a flow of air which assists in controlling the shape of the arc column at low current values. This control causes the arc to make an earlier transfer to the arc runners, thereby energizing the magnetic circuit which drives the arc into the carrier stack. This action produces a shorter arcing time than would be possible by relying only on the thermal effects of the arc to achieve the transfer to the arc runners.

Puffers should be inspected during regular breaker maintenance periods. Hoses should be checked for flexibility, freedom from kinking or collapse and soundness of connection to mating parts. Cylinders should be checked for cleanliness and freedom from deposits which might retard the motion of the piston. Pistons should be checked for free movement within the cylinder and that the seals are flexible and contact the walls of the cylinder. Transformer oil is used on felt seals to keep the material pliable, reduce shrinkage and to provide lubrication. The oil should moisten but not saturate the felt.

Replace seal material if it becomes inflexible or does not make contact with the cylinder walls.

The air output from the puffer nozzle may be checked with the arc chutes tilted (refer to "Tilting Arc Chutes", page 11 and Fig. 2. Crush a 4 1/2 x 4 1/2 inch sheet of tissue paper, place it in the nozzle opening and check to see that it is dislodged when the breaker is opened.

# CIRCUIT BREAKER HANDLING INSTRUCTIONS

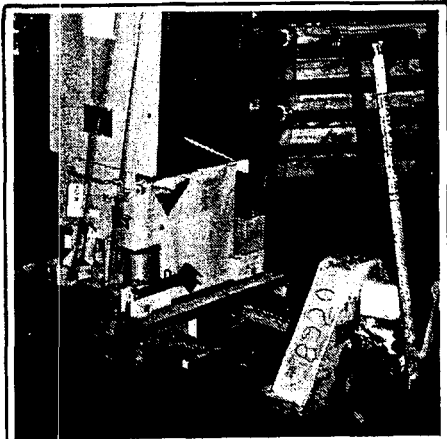

(A)

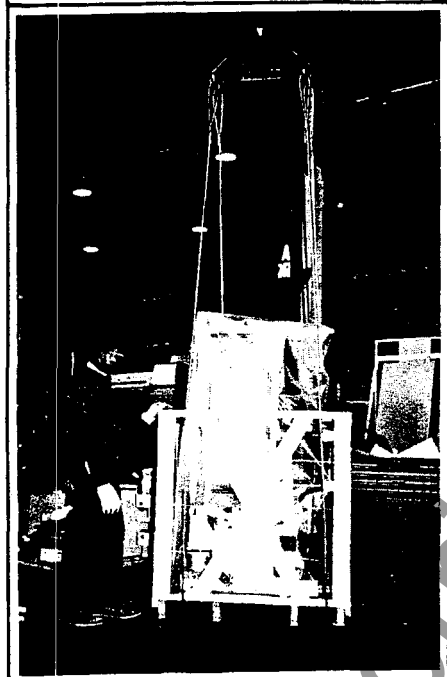

(B)

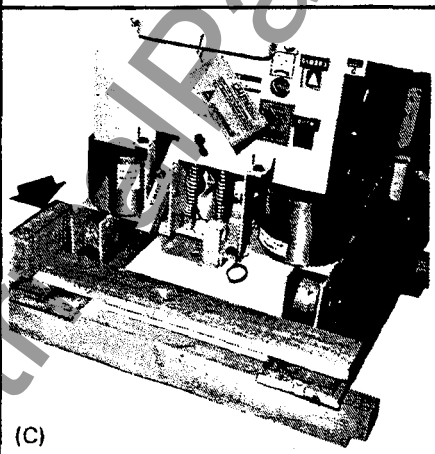

(C)

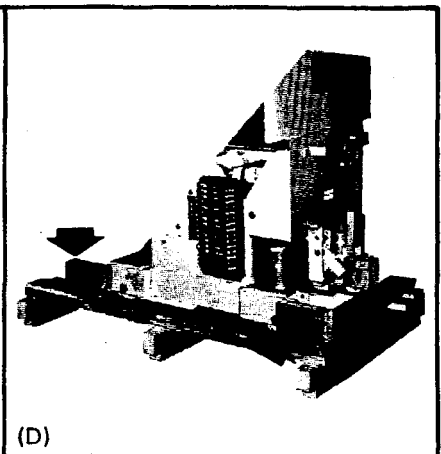

(D)

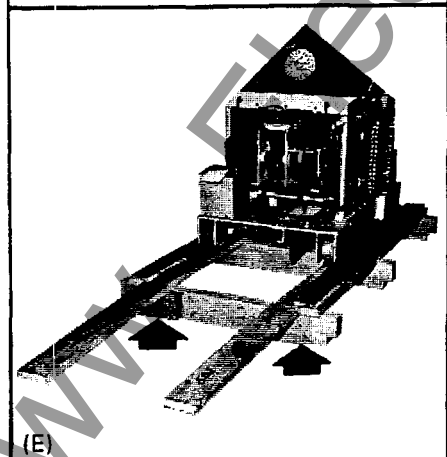

(E)

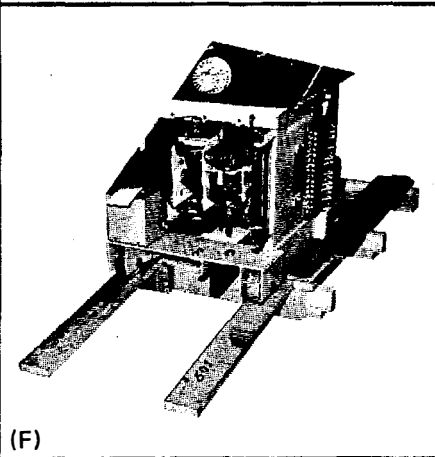

(F)

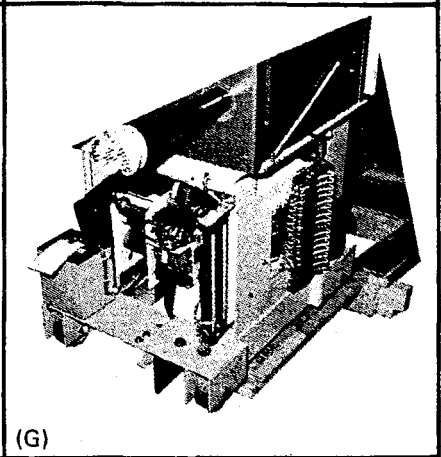

(G)

- Move 5-kv breaker to installation location with fork lift (A).
- Move 15-kv breaker to installation location with fork lift or crane (B).
- Carefully remove protective plastic cover or crate.
- Remove t-shaped pieces nailed to the pallet, in front of the rear and back wheels of the breaker (C & D).
- Place t-shaped pieces in front of the pallet in line with breaker wheels (E) and nail to pallet as shown by arrows in (E).
- Slowly roll breaker off pallet (F & G).

**CAUTION – REMOVE TRIP LATCH AND FOOT LEVER INTERLOCK RELEASE BLOCKING BEFORE INSERTING OR STORING BREAKER IN CUBICLE.**

Fig. 1 – Circuit Breaker Handling Instructions

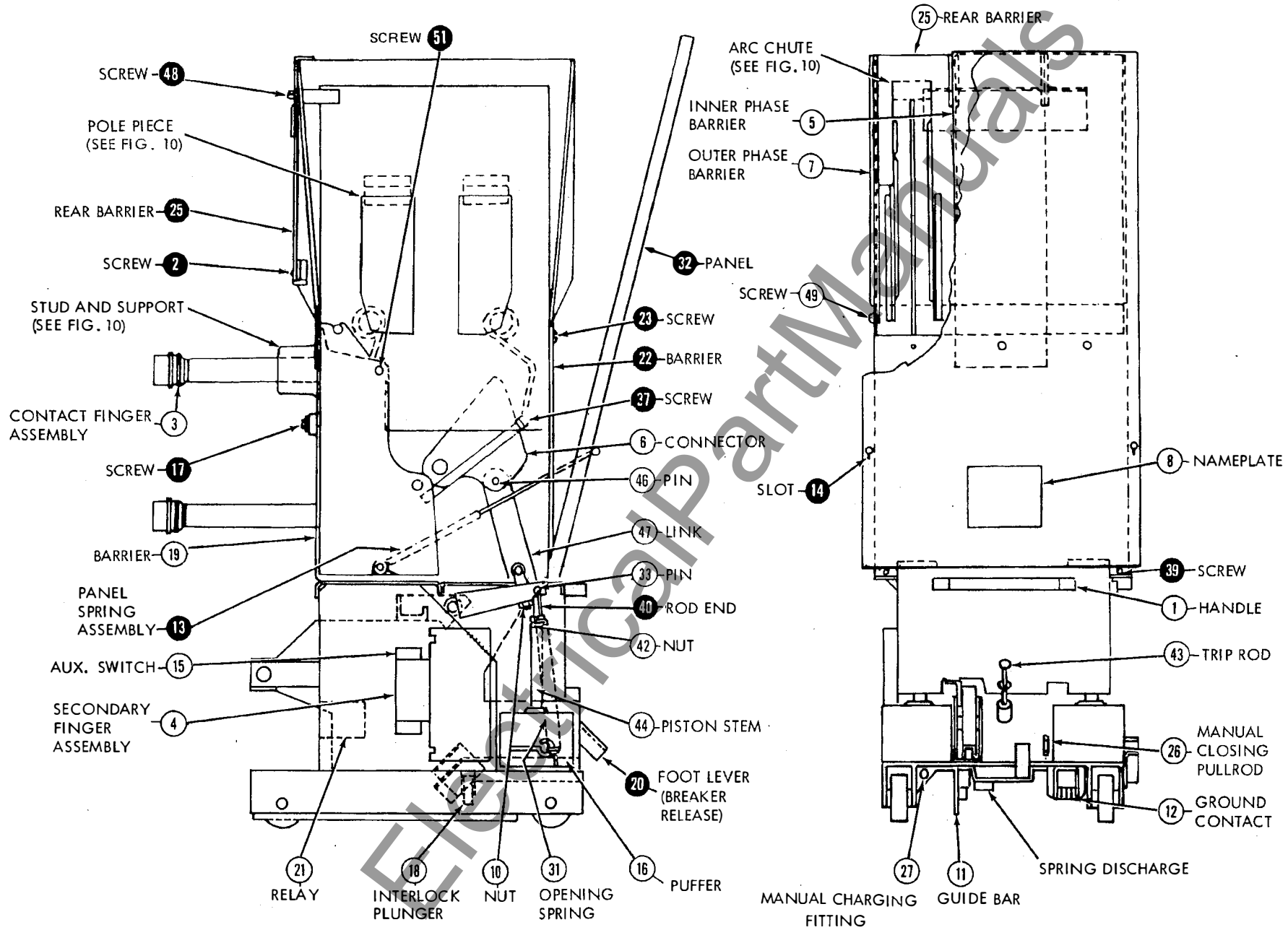

Fig. 2 — Typical Circuit Breaker Assemblies

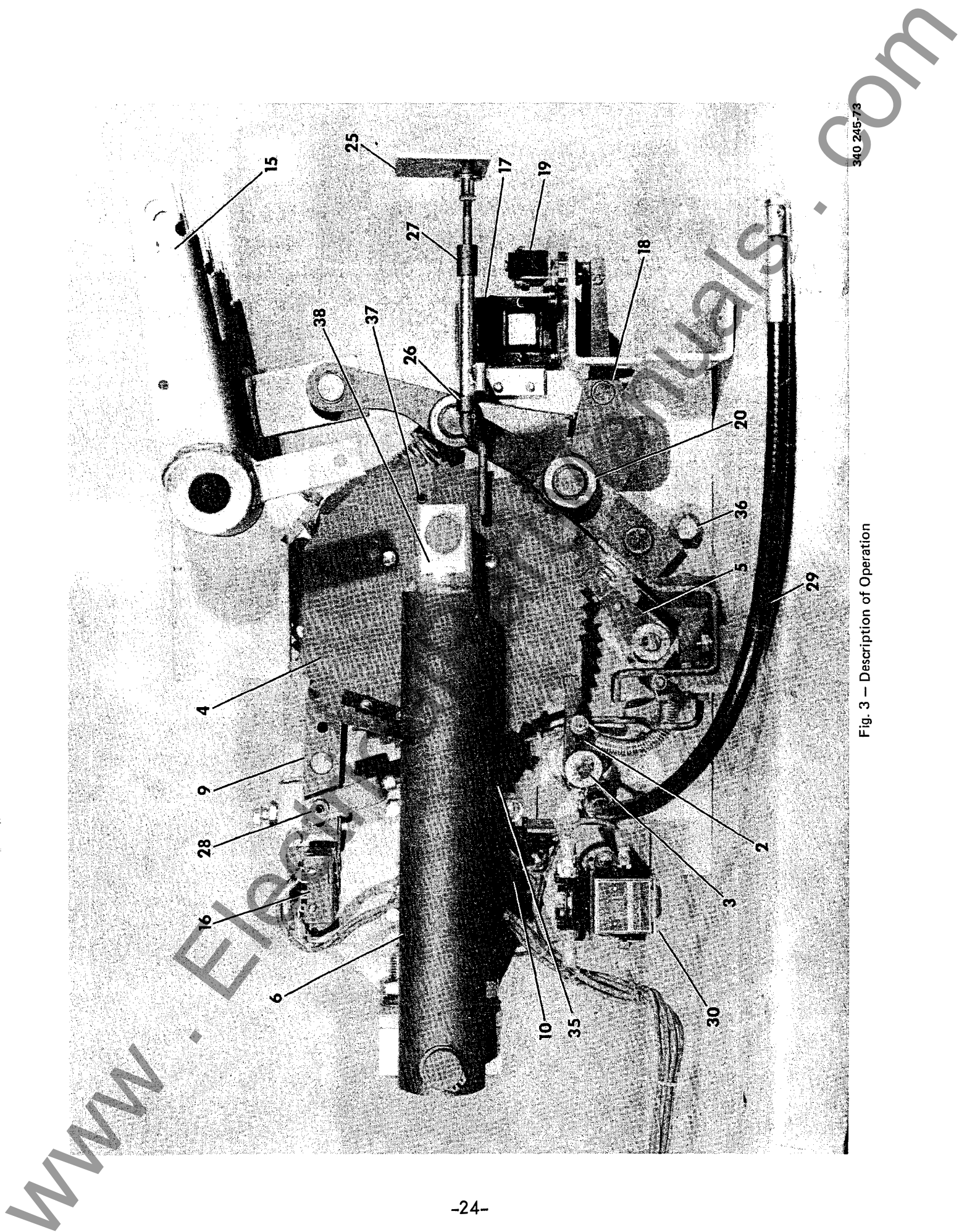
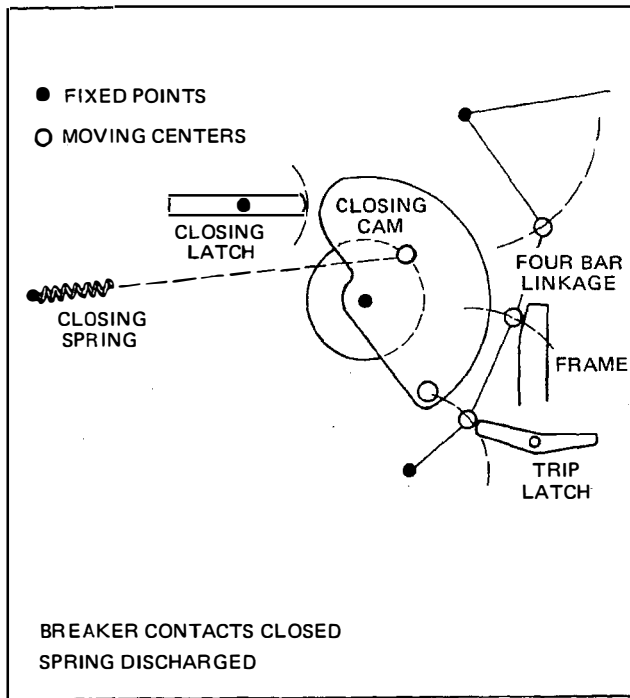
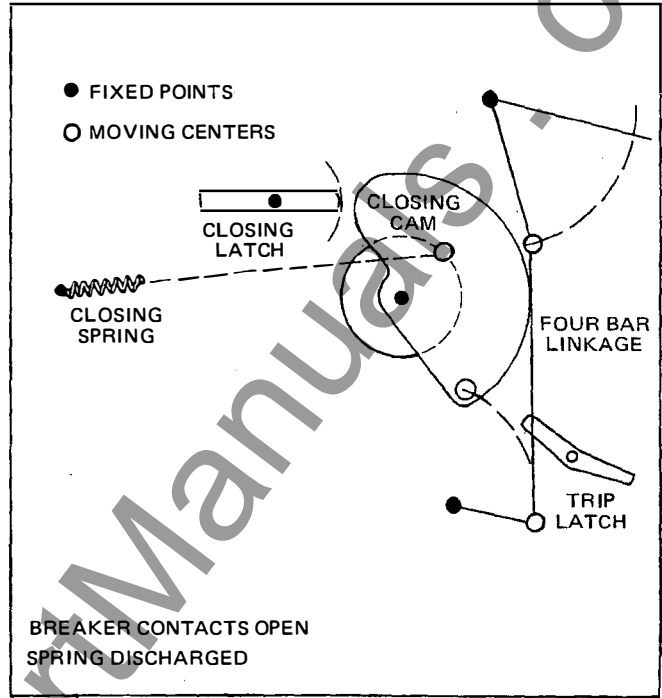

Fig. 3 — Description of Operation

340 245-73



-A-



-B-

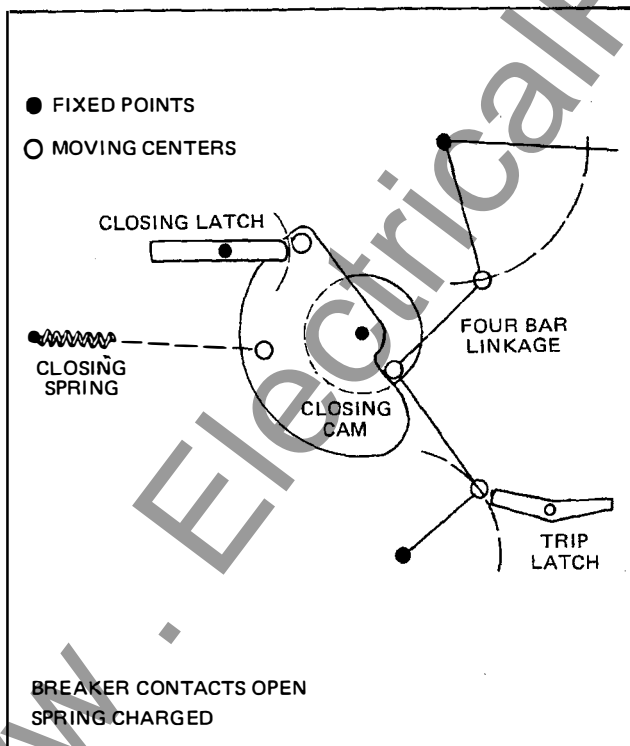

-C-

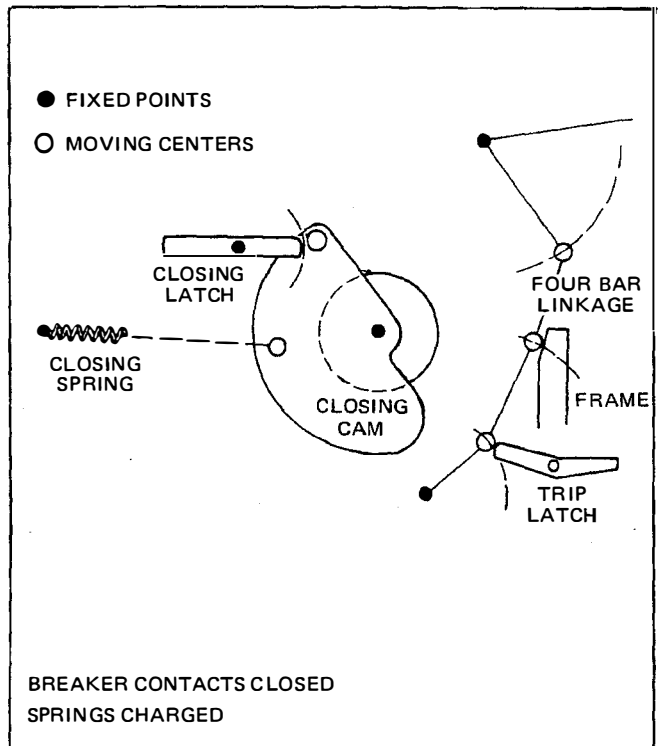

-D-

Fig. 4 - Breaker Contacts

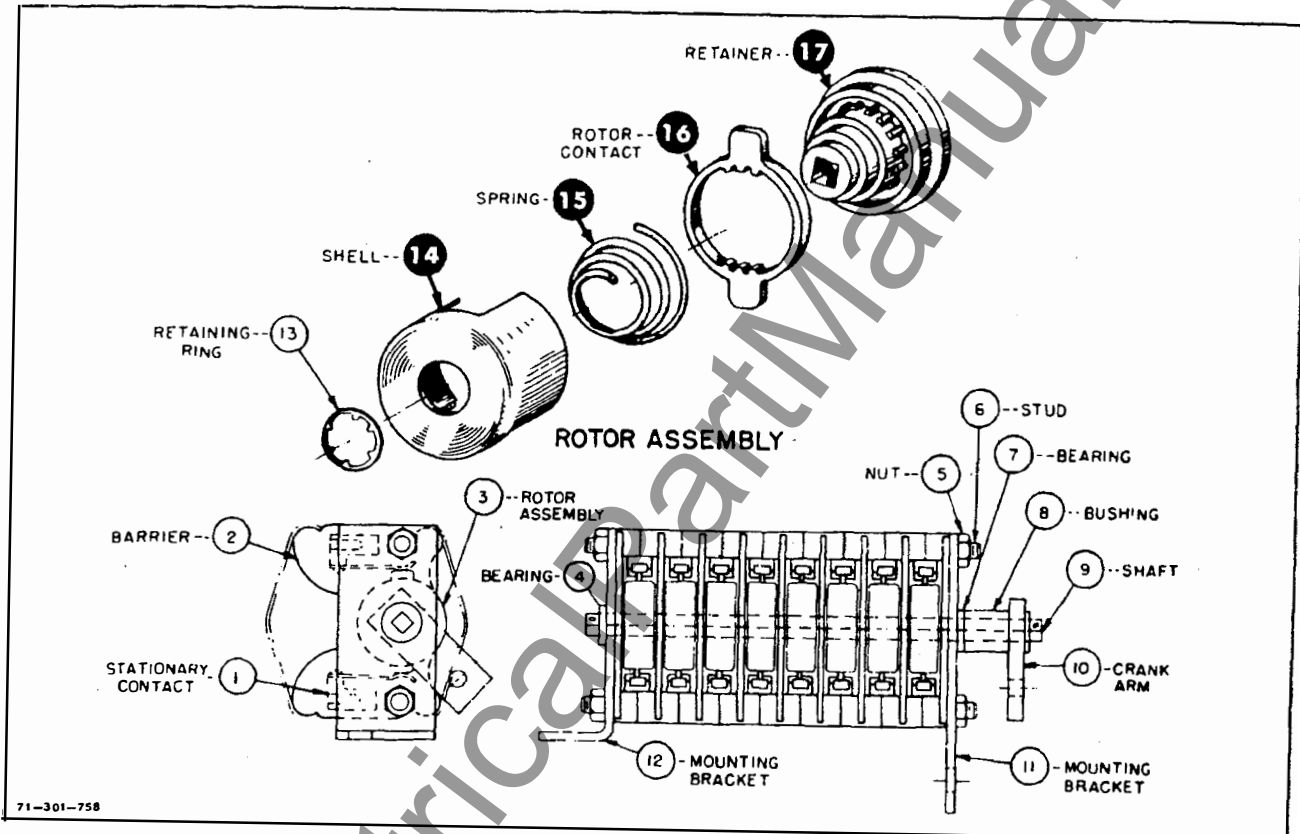

71-301-758

Fig. 5 - Type Q-10 Auxiliary Switch

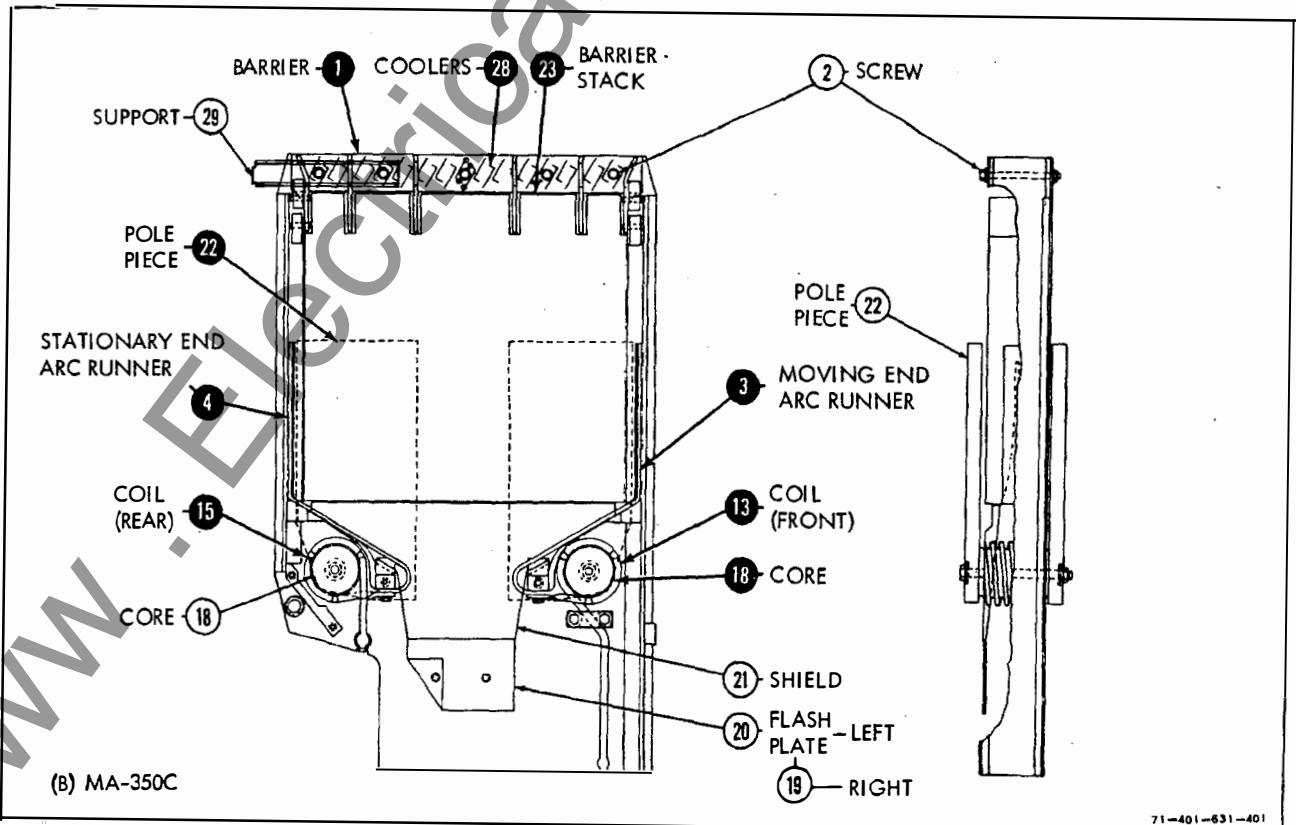
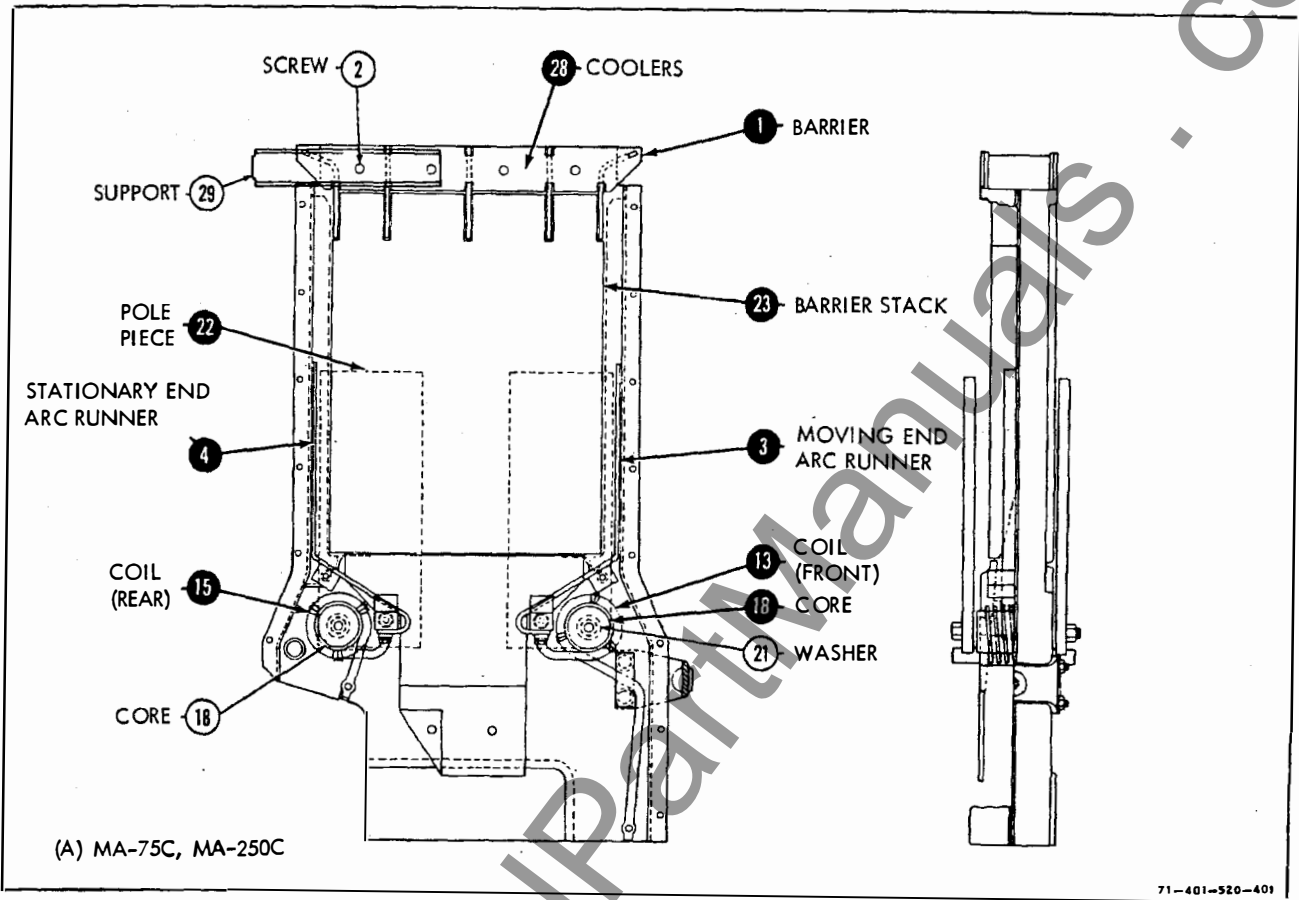

Fig. 6 - Arc Chutes

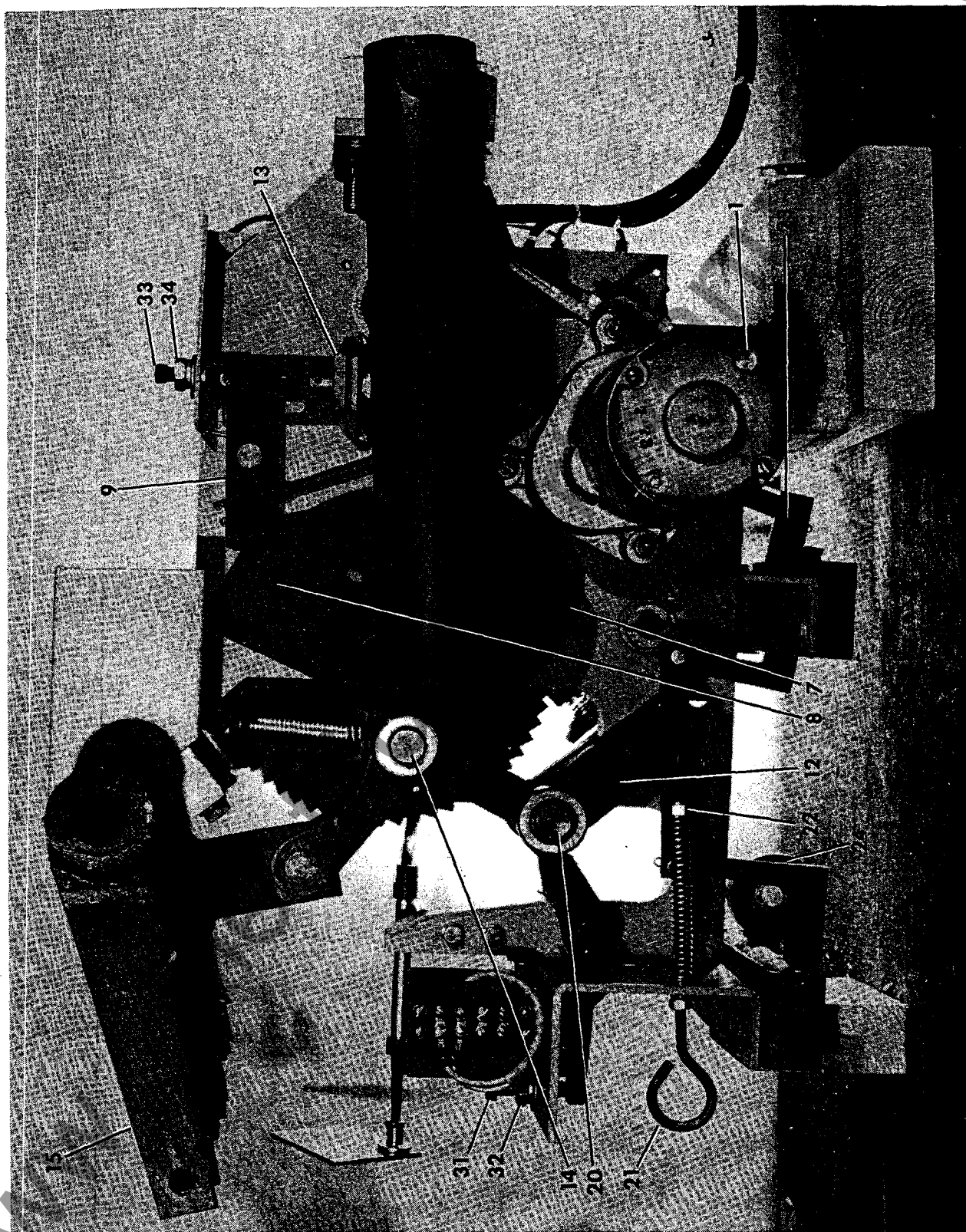

Fig. 7 — Description of Operation

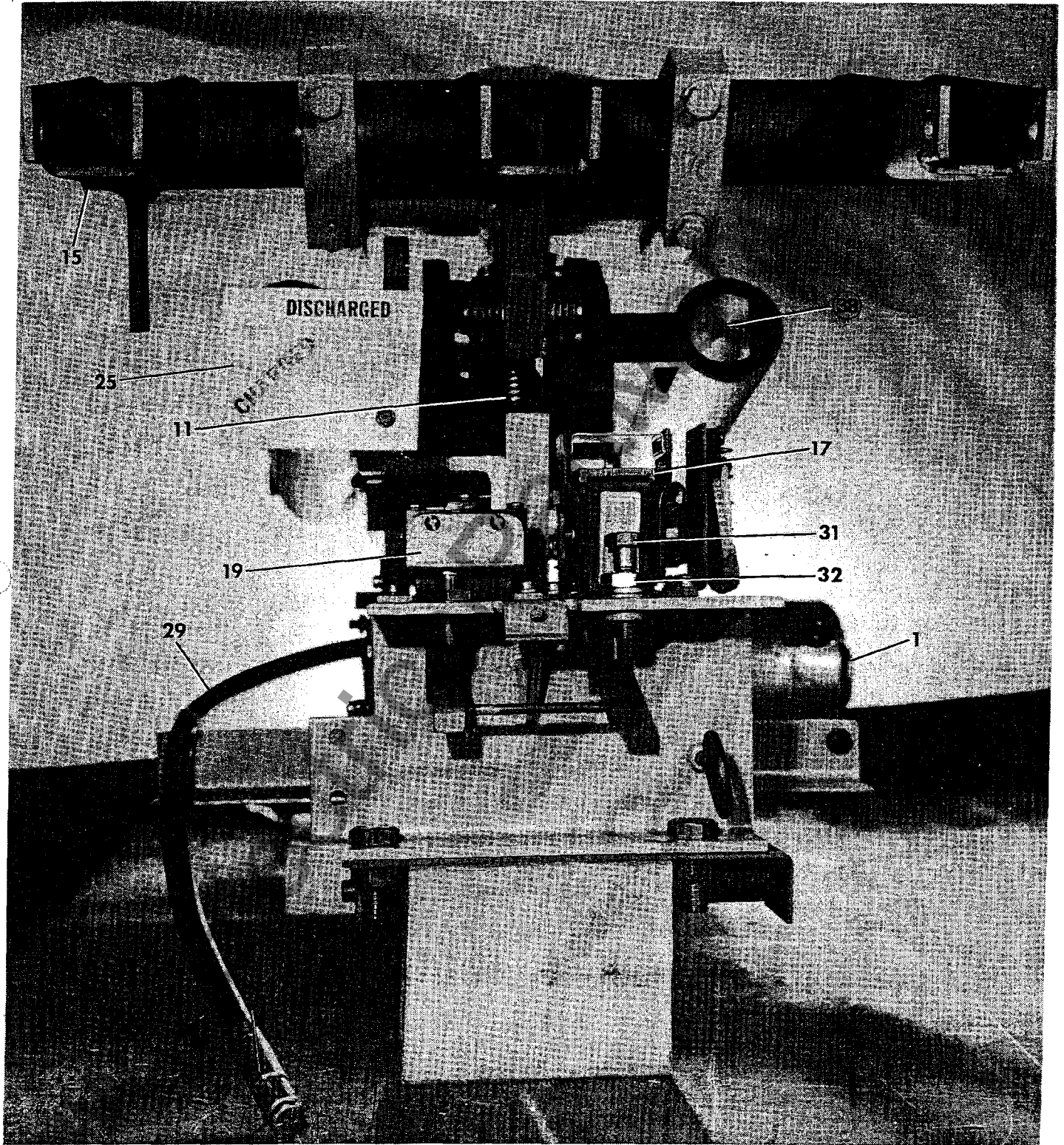

Fig. 8 - Description of Operation

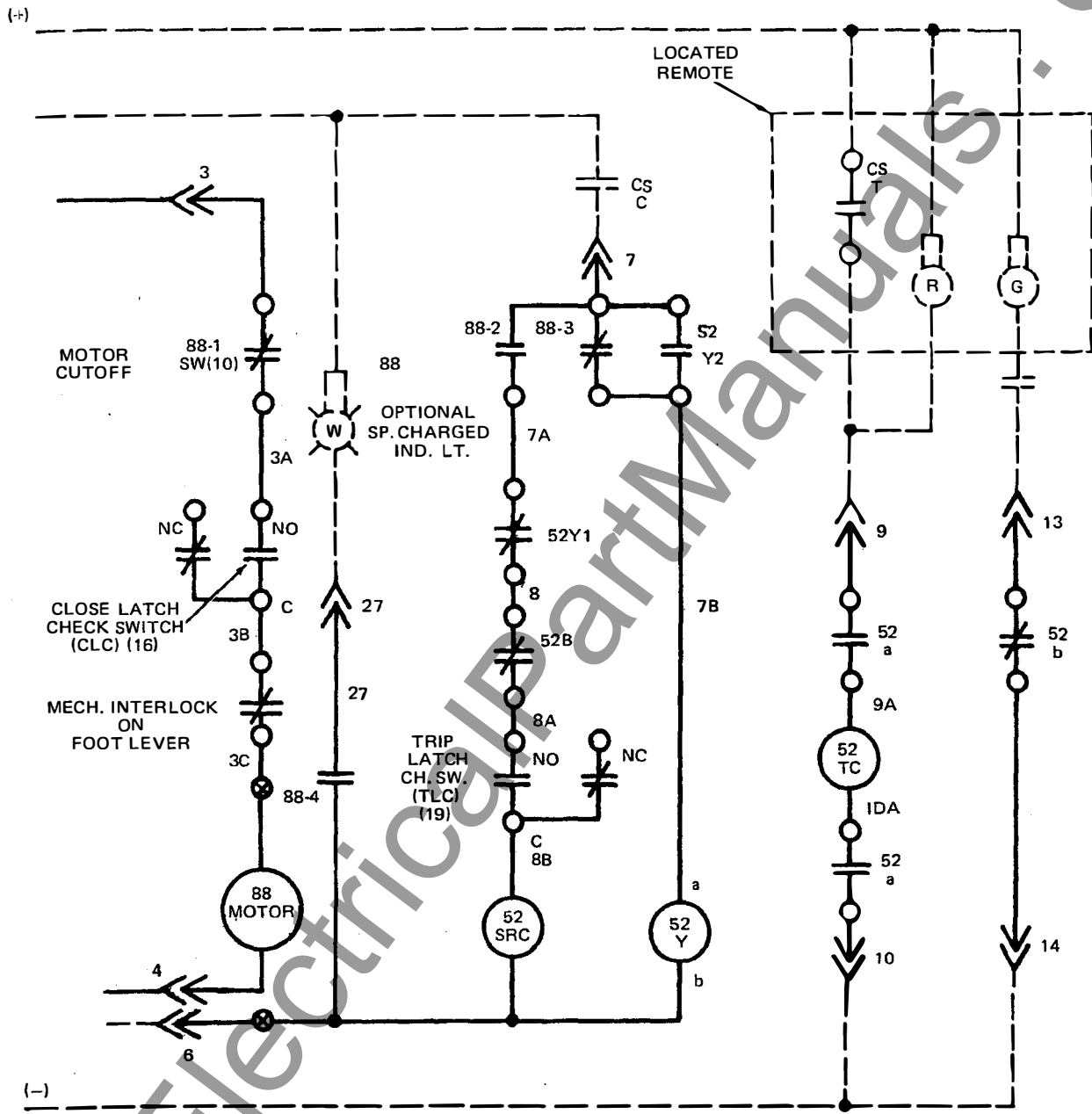

Fig. 9 – Control Scheme for Stored Energy Operator

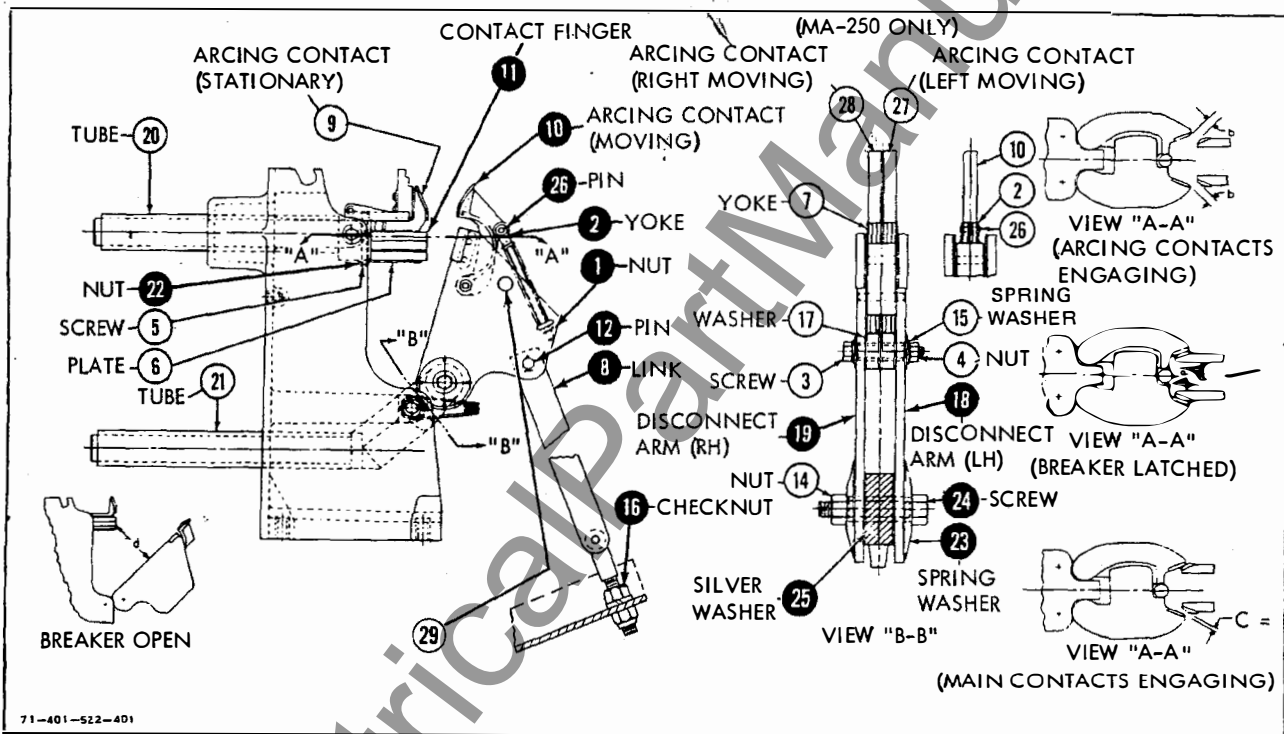

Fig. 10 - Stud and Support Assembly

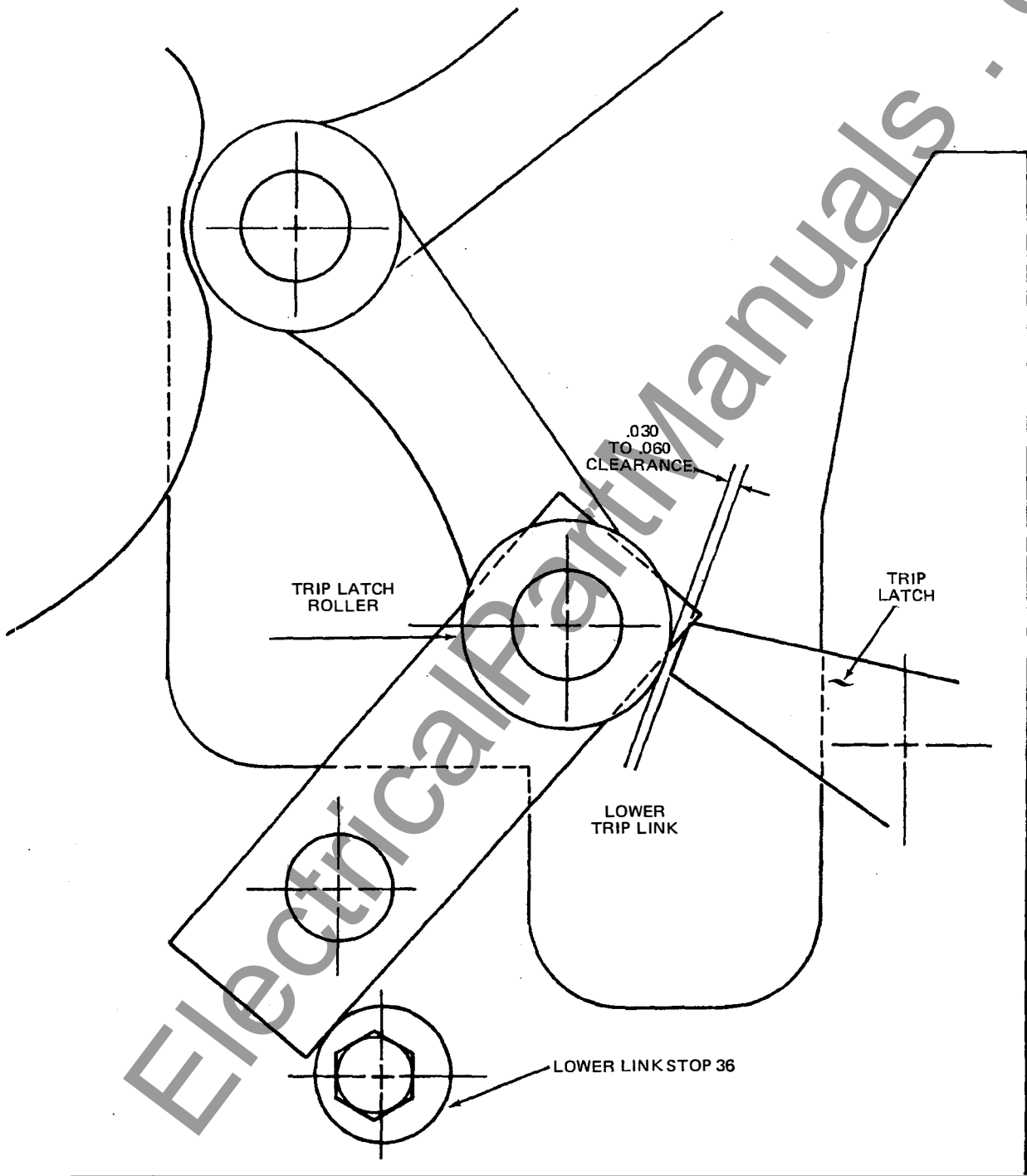

Fig. 11 – Trip Latch Clearance Adjustment

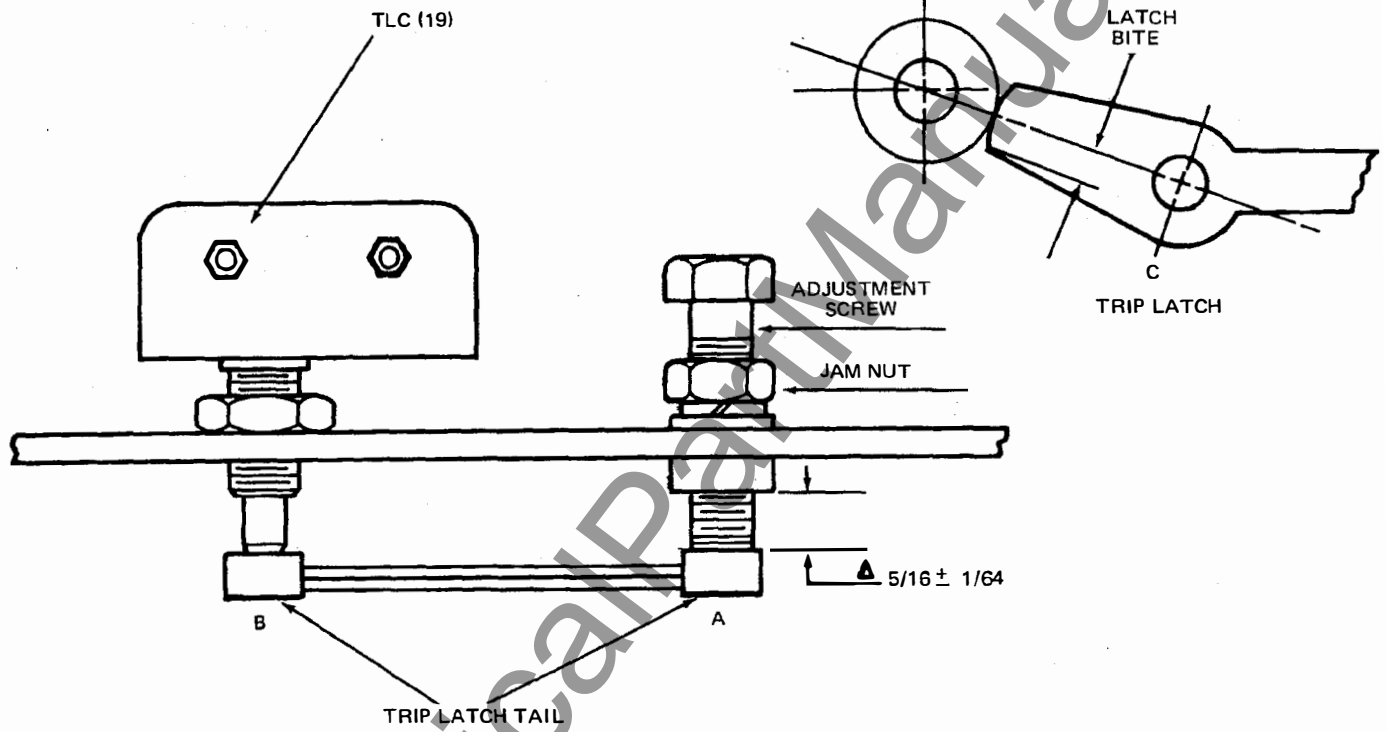
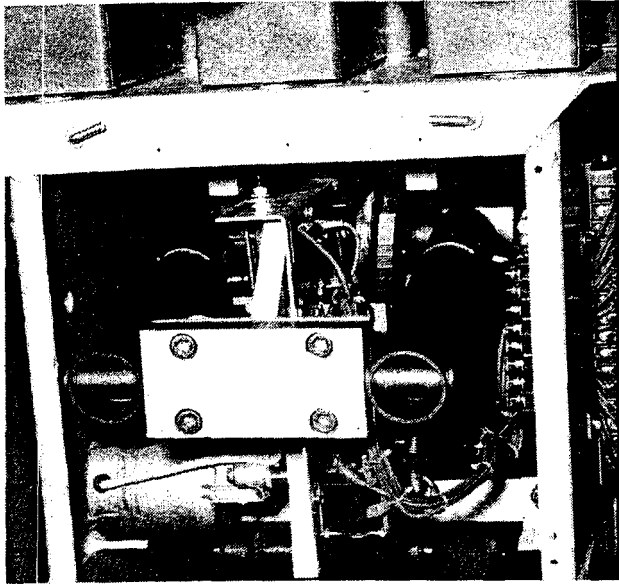
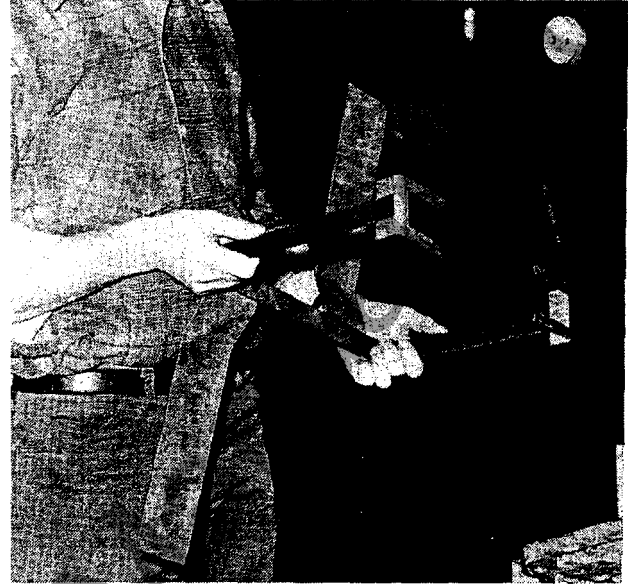

Fig. 12 – Trip Latch Bite and Check Switch Adjustments



340064

BREAKER CHARGED AND READY TO RECEIVE SPRING BLOCKING DEVICE:



340063

SPRING BLOCKING DEVICE IN CORRECT POSITION FOR INSERTION

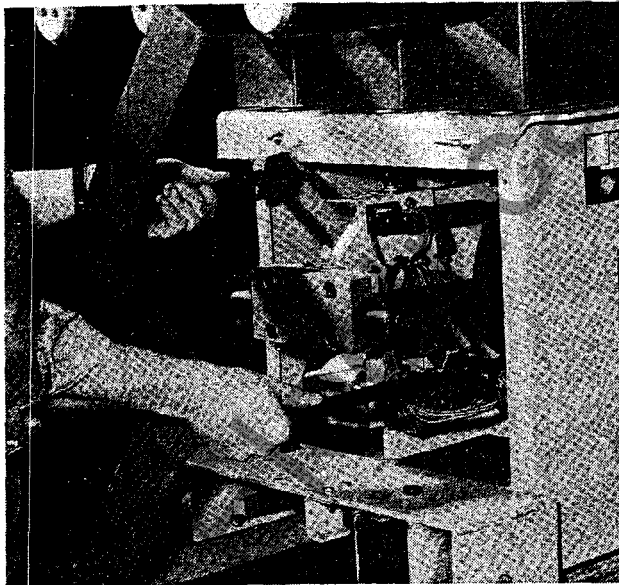

340065

INSERTION OF THE SPRING BLOCKING DEVICE. NOTE: SPRING BLOCKING DEVICE MUST BE DIAGONALLY INSERTED TO CLEAR BREAKER FRAME.

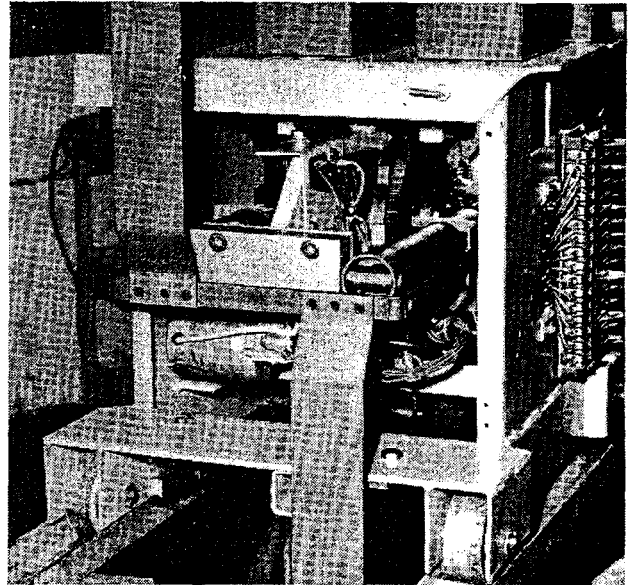

340066

SPRING BLOCKING DEVICE IN PLACE READY FOR CLOSING SPRING RELEASE.

Fig. 13. Maintenance Close Spring Blocking Device Insertion

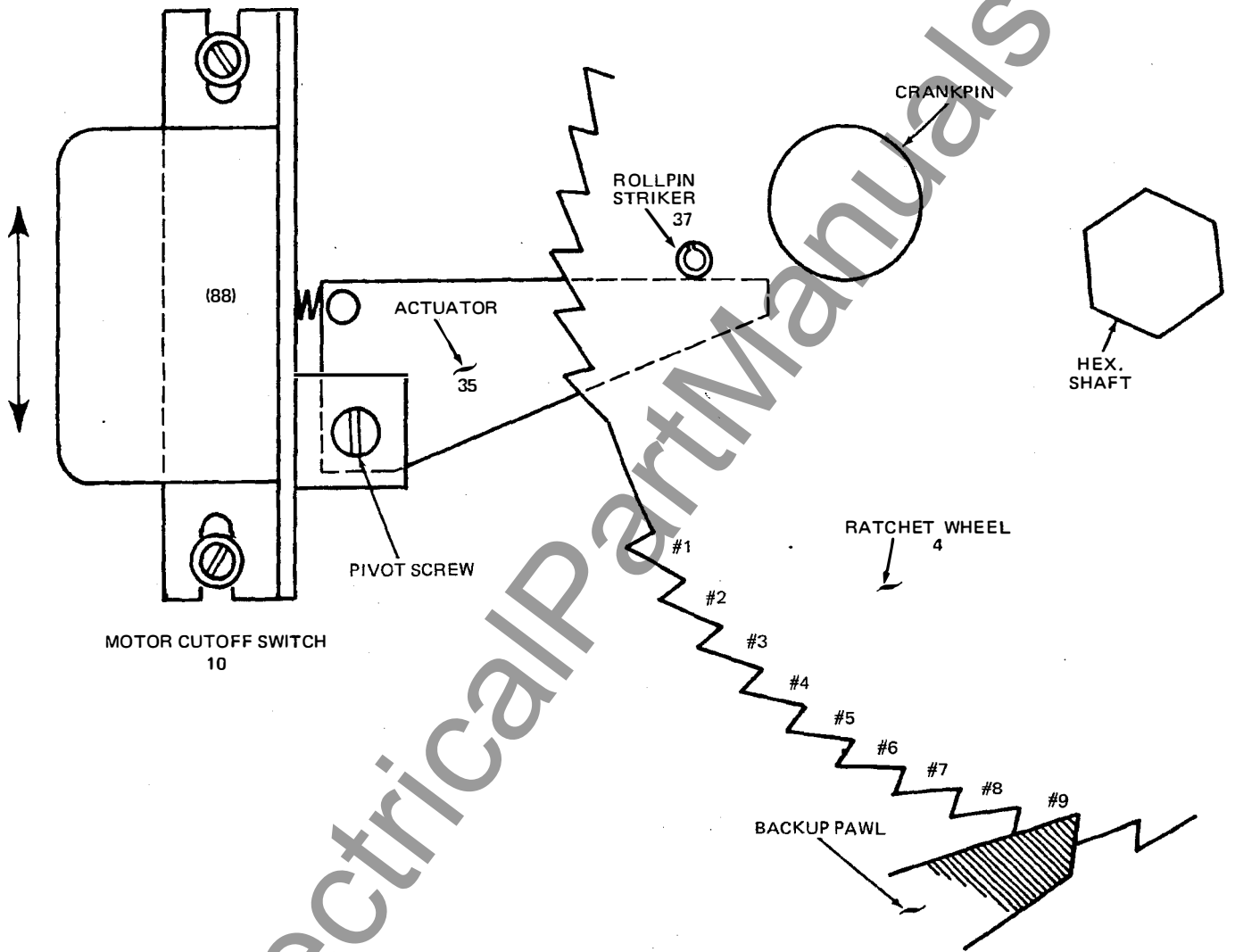

Fig. 14 – Motor Cutoff Switch

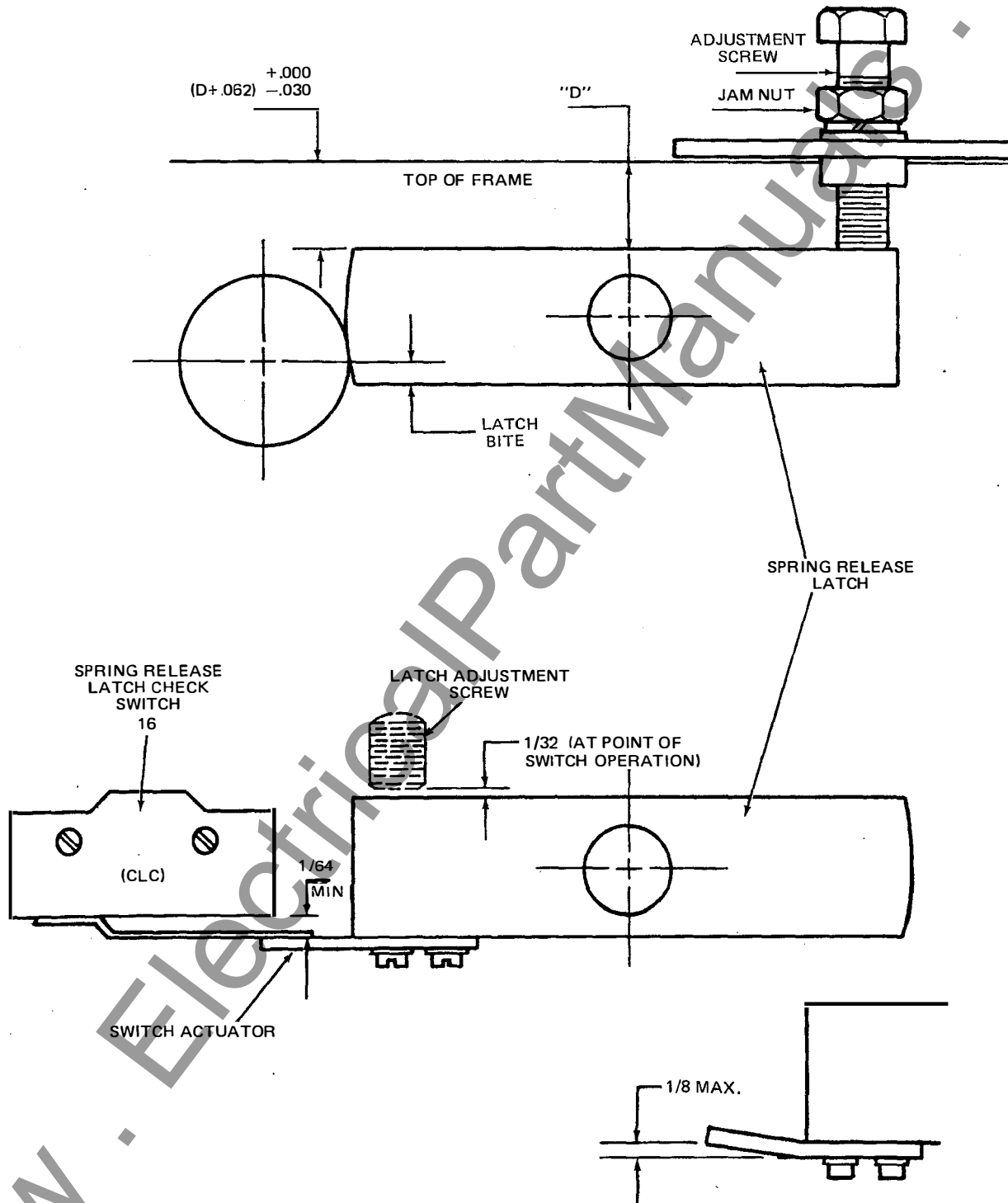
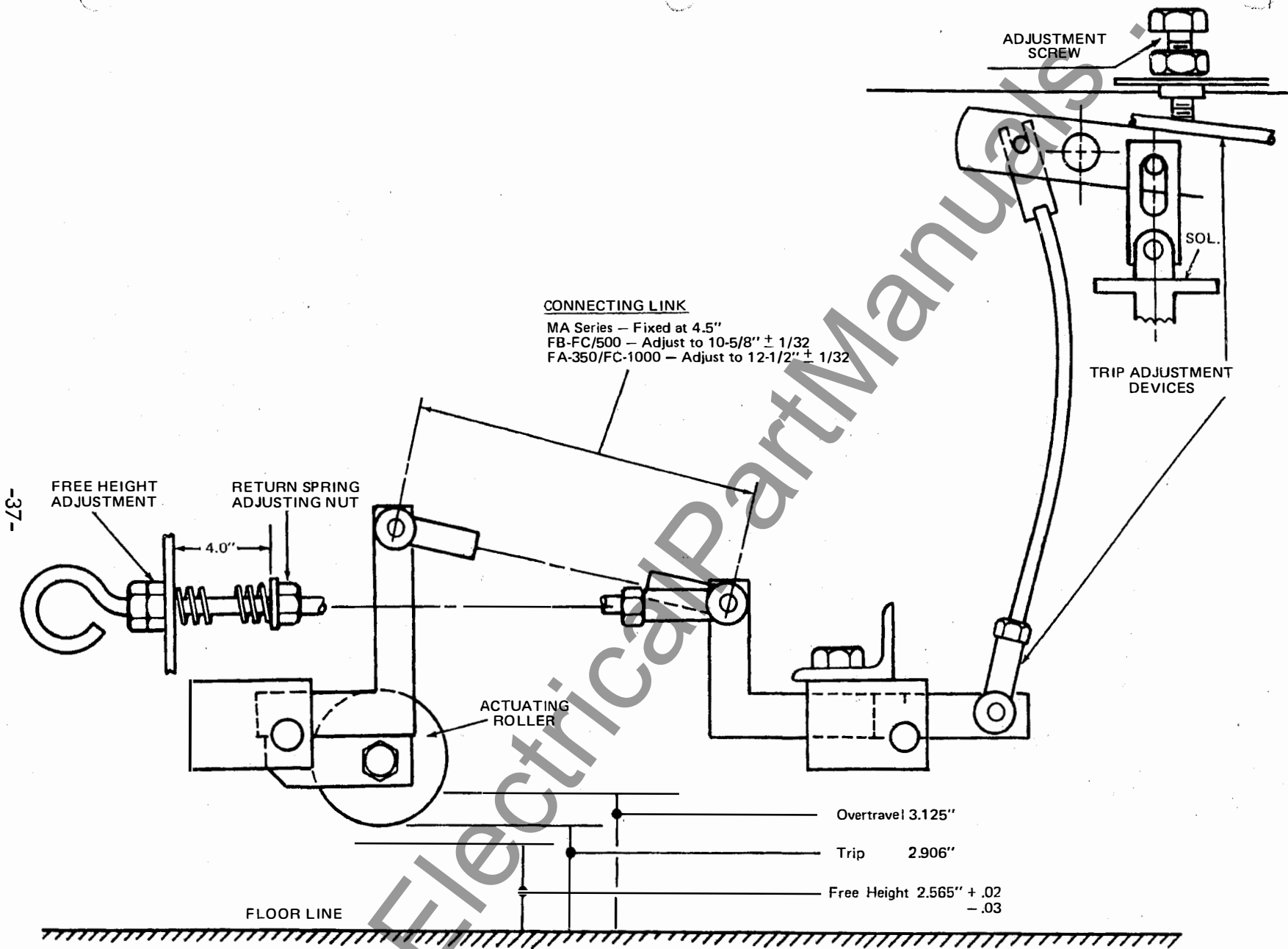

Fig. 15 – Spring Release Latch Bite and Check Switch Adjustments



**CONNECTING LINK**  
 MA Series – Fixed at 4.5"  
 FB-FC/500 – Adjust to  $10\text{-}5/8'' \pm 1/32$   
 FA-350/FC-1000 – Adjust to  $12\text{-}1/2'' \pm 1/32$

Overtravel 3.125"  
 Trip 2.906"  
 Free Height  $2.565'' + .02$   
 $-.03$

Fig. 16 – Closing Spring Dump Mechanism

-37-

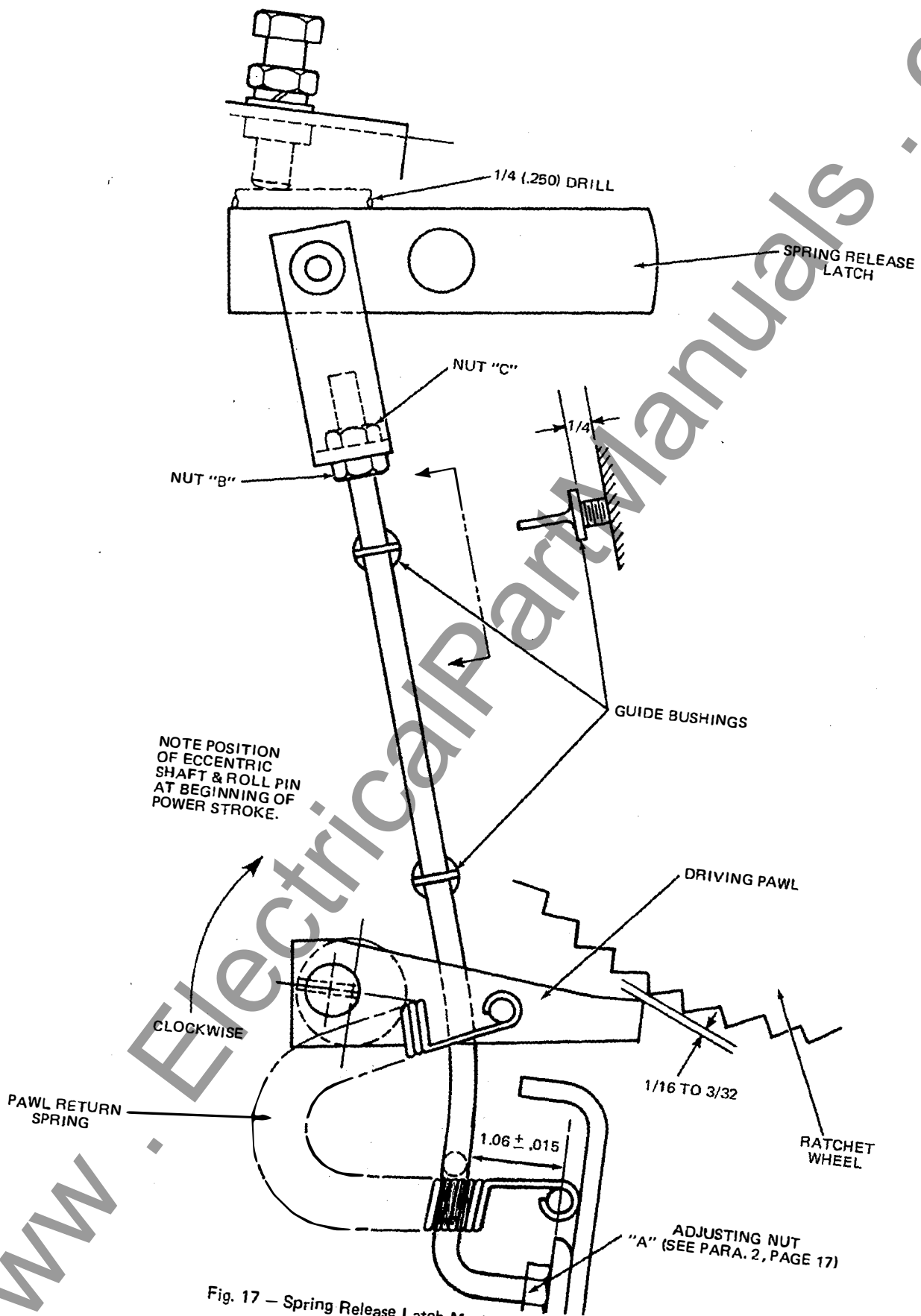
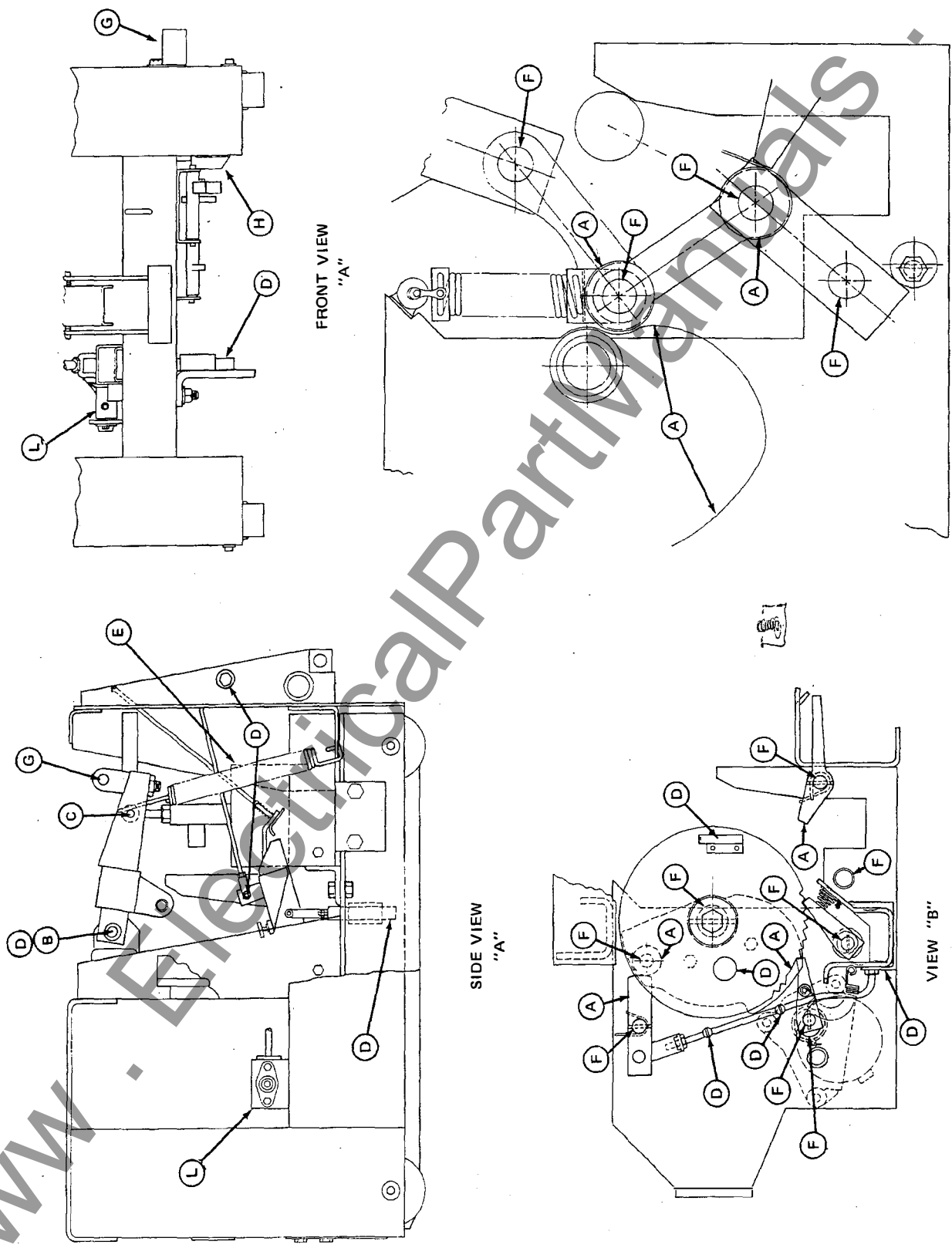
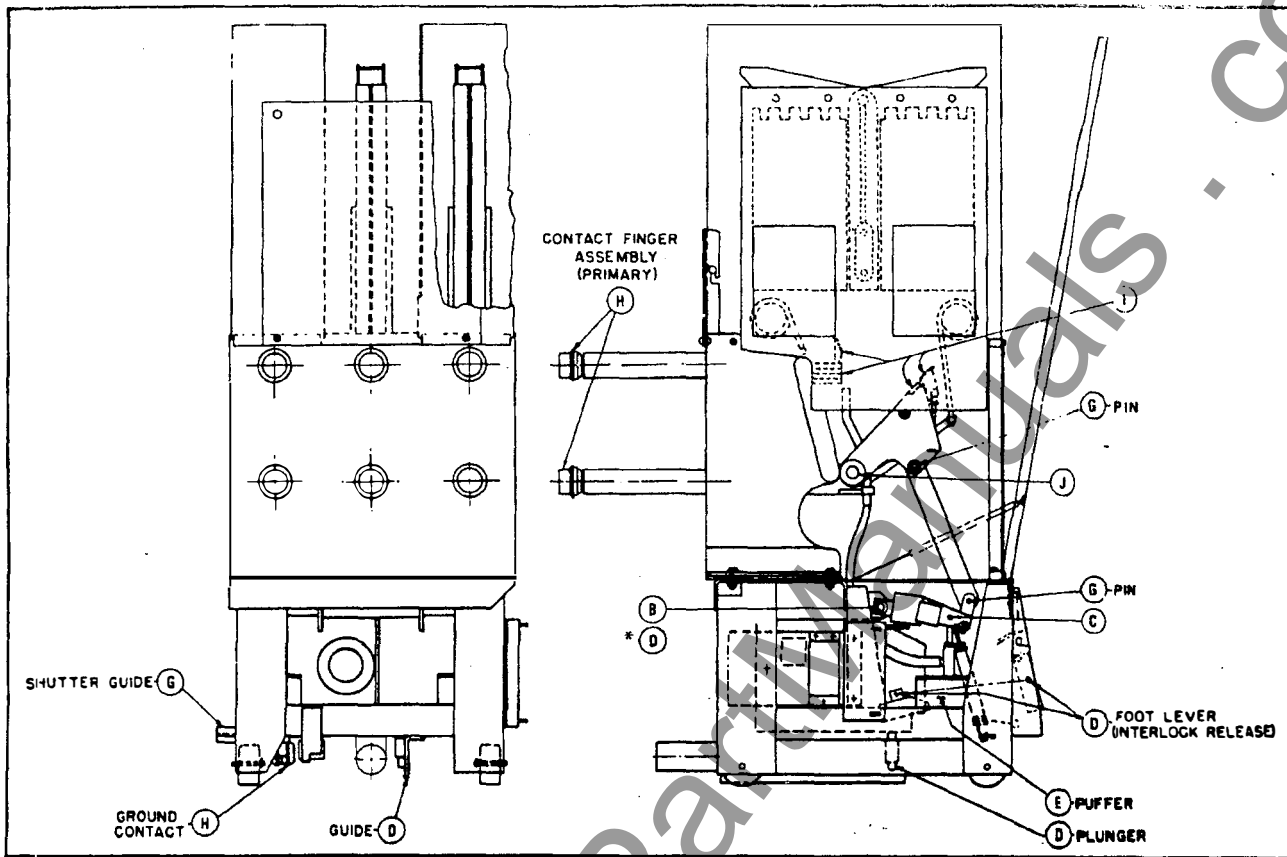

Fig. 17 - Spring Release Latch Mechanical Interlock



VIEW "C"

Fig. 18. Frame And Operator, Drive Assembly And Linkage Assembly



\*REFERENCE ON NIA SERIES  
TO ITEM D. ITEM B REQ'D ON  
ALL OTHER BREAKERS

Fig. 19 Lubrication Points on Breaker

LUBRI-CATION KEY	PART DESCRIPTION	SUGGESTED LUBRICATION AT EVERY 2000 OPERATIONS OR ONCE EVERY YEAR.	ALTERNATE LUBRICATION (REQUIRES DISASSEMBLY) RECOMMENDED AFTER EVERY 10,000 OPER.
A	GROUND SURFACES SUCH AS LATCHES, ROLLERS, PROPS, ETC.	WIPE CLEAN AND SPRAY WITH *MOLYCOTE 557* 15-171-270-001.	WASH CLEAN AND SPRAY WITH *MOLYCOTE 557* 15-171-270-001.
B	NYLON SLEEVE BEARINGS, SUCH AS: THE CONTACT ARM HINGE PIN.	NO LUBRICATION REQUIRED.	NO LUBRICATION REQUIRED.
C	SLEEVE BEARINGS AND PIVOT PINS, ROTATING PARTS SUCH AS DRIVE PINION, DRIVING CRANKS, WALKING BEAM PIVOT PIN, SLIDE AND PIVOT PIN.	LIGHT APPLICATION OF *MOLYCOTE PENELUBE* 15-171-270-002.	REMOVE PINS OR BEARINGS, CLEAN PER INSTRUCTIONS AND APPLY *BEACON P-290* 00-337-131-001.
D	SLIDING SURFACES SUCH AS: THE MAIN SOLENOID ARMATURE.	LIGHT APPLICATION OF *MOLYCOTE 557*.	WIPE CLEAN AND APPLY *MOLYCOTE 557* LIBERALLY.
E	AIR PUFFER CYLINDERS.	WIPE CLEAN AND APPLY TRANSFORMER OIL # 3 TO FELT.	WASH CLEAN AND WET FELT RING IN TRANSFORMER OIL # 3.
F	ROLLER AND NEEDLE BEARINGS.	NO LUBRICATION REQUIRED.	CLEAN PER INSTRUCTIONS AND REPACK WITH *BEACON P-325*.
G	DRY PIVOT POINTS.	NO LUBRICATION REQUIRED.	NO LUBRICATION REQUIRED.
H	PRIMARY DISCONNECT FINGERS, GROUNDING CONTACT.	WIPE CLEAN AND APPLY A THIN FILM OF ALLIS-CHALMERS CONTACT LUBRICANT 15-171-370-002.	
I	ARCING CONTACTS.	DO NOT LUBRICATE.	DO NOT LUBRICATE.
J	CONTACT ARM HINGE ASSEMBLY, SILVER WASHER BETWEEN BUSHING AND THE CONTACT ARM.	WIPE CLEAN AND APPLY A THIN FILM OF ALLIS-CHALMERS CONTACT LUBRICANT 15-171-370-002.	
K	CHARGING SPRINGS & SPRING RETAINERS	NO LUBRICATION REQUIRED	WIPE CLEAN AND COAT WITH OF BEACON P-325.
L	MANUAL CHARGING BEVEL GEAR TRAIN FB & FC SERIES ONLY.	REMOVE SNAP ON COVER & COAT TEETH LIGHTLY WITH BEACON P-325.	REMOVE SNAP ON COVER & COAT TEETH LIGHTLY WITH BEACON P-325.
M	ARCING CONTACT HINGE ASSEMBLY, SILVER WASHERS BETWEEN BUSHING AND CONTACT ARMS.	WIPE CLEAN AND APPLY A THIN FILM OF ALLIS-CHALMERS CONTACT LUBRICANT 15-171-370-002.	

Fig. 20 Lubrication Chart