

INDEX TO INSTRUCTION BOOK

SECTION I

INSTALLATION AND INSPECTION

- A. INTRODUCTION
- B. WARRENTY
- C. RECEIVING AND INSPECTION FOR DAMAGE
- D. CAUTIONS TO BE OBSERVED
- E. INSTALLATION
- F. STORAGE
- G. MAINTENANCE
- H. RENEWAL PARTS

SECTION II

OPERATION

- A. DESCRIPTION
  - 1. Manually Operated Breaker
  - 2. Electrically Operated Breaker
- B. RACKING MECHANISM, DRAWOUT INTERLOCK AND LIFTING BAR
- C. SPRING DISCHARGE MECHANISM
  - 1. Description and Function
  - 2. Adjustments

SECTION III

MAINTENANCE AND ADJUSTMENTS

- A. MAINTENANCE
- B. LUBRICATION
- C. MAINTENANCE CLOSING
- D. ADJUSTMENTS
- E. CONTACT REPLACEMENT

SECTION IV

STATIC OVERCURRENT TRIP DEVICE

- A. INTRODUCTION
- B. DESCRIPTION
  - 1. Selection of Settings
  - 2. Maintenance and Testing
  - 3. Release Magnet

SECTION V

FUSE FUNCTIONS

- A. CURRENT LIMITING FUSE
- B. TRIGGER FUSE

[www.ElectricalPartManuals.com](http://www.ElectricalPartManuals.com)

## LIST OF ILLUSTRATIONS

<u>FIGURE NO.</u>	<u>DESCRIPTION</u>
1	TYPICAL LA-1600 BREAKER OUTLINE
2	TYPICAL OPERATING MECHANISM (MANUALLY OPERATED BREAKER)
2A	TYPICAL OPERATING MECHANISM (ELECTRICALLY OPERATED BREAKER)
3	TYPICAL WIRING DIAGRAM FOR ELECTRICALLY OPERATED BREAKERS
4	TYPICAL RACKING MECHANISM & DRAWOUT INTERLOCK
5	MAINTENANCE CLOSING
6	TYPICAL PANEL ASSEMBLY
7	TYPICAL STATIC OVERCURRENT TRIP DEVICES
7A	TYPICAL BREAKER RATING PLATE AND CURRENT TRANSFORMERS
7B	SHAFT LOCKS AND CALIBRATION MARKS FOR STATIC TRIP DEVICES
7C	PORTABLE TEST SET FOR STATIC TRIP DEVICES
7D	TYPICAL TRIP CURVES (SELECTIVE STATIC TRIP)
7E	TYPICAL TRIP CURVES (DUAL STATIC TRIP)
7F	CONNECTIONS FOR FUNCTION TEST
8	TYPICAL RELEASE MAGNET
11	TYPICAL SECONDARY DISCONNECTS
12	TYPICAL AUXILIARY SWITCH
13	TYPICAL SHUNT TRIP
14	TYPICAL UNDERVOLTAGE DEVICE
15	TYPICAL BELL ALARM (MANUAL RESET)
15A	TYPICAL BELL ALARM (ELECTRICAL RESET)
16	CURRENT LIMITING AND TRIGGER FUSE
17	SPRING DISCHARGE MECHANISM

## TABLES

<u>TABLE NO.</u>	
1.	OPERATING PROCEDURE (MANUALLY OPERATED BREAKER)
2.	OPERATING PROCEDURE (ELECTRICALLY OPERATED BREAKER)
3.	MAINTENANCE CLOSING
4.	CURRENT TRANSFORMERS (Fig. 7A)

[www.ElectricalPartManuals.com](http://www.ElectricalPartManuals.com)

INSTRUCTIONS  
FOR THE INSTALLATION AND OPERATION  
OF ALLIS-CHALMERS TYPE "LA"  
LOW VOLTAGE AIR CIRCUIT BREAKERS  
AND AUXILIARY EQUIPMENT

SECTION I, INSTALLATION AND INSPECTION

A. INTRODUCTION The type "LA" air circuit breakers may be furnished for mounting in any one of three ways. They may be used in metal enclosed switchgear of the drawout type, in individual enclosures (pullout type), or for stationary mounting in a customer's own enclosing case or switchboard. All "LA" breakers are completely assembled, tested, and calibrated at the factory in a vertical position and must be so installed to operate properly. Customer's primary connections should be adequately braced against the effects of short circuit currents to prevent overstressing the breaker terminals.

B. WARRANTY Allis-Chalmers "LA" air circuit breakers are warranted to be free of defects in material and workmanship for a period of one year after delivery to the original purchaser. This warranty is limited to the furnishing of any part which to our satisfaction has been proven defective. Allis-Chalmers will not in any case assume responsibility for allied equipment of any kind.

C. RECEIVING AND INSPECTION FOR DAMAGE Immediately upon receipt of this equipment, carefully remove all packing traces and examine parts, checking them against the packing list and noting any damages incurred in transit. If such is disclosed, a damage claim should be filed at once with the transportation company and Allis-Chalmers notified.

D. CAUTIONS TO BE OBSERVED IN THE INSTALLATION AND OPERATION OF "LA" CIRCUIT BREAKERS

1. Read Instruction Book before installing or making any changes or adjustments on the breaker.
2. As the closing springs on stored-energy breakers may be charged in either the breaker open or closed position, extreme care should be taken to discharge the springs before working on the breaker.
3. When closing manually-operated breakers, always grasp closing handle firmly until it is returned to the normal vertical position.
4. Check current ratings and serial numbers against single line diagram to assure that breakers are properly located in switchgear at installation.
5. Check the alignment of the secondary disconnect fingers to ensure against misalignment due to possible distortion of fingers during shipment and handling.
6. Once the breaker is energized, it should not be touched, except for operating, since most of the component parts are also energized.

[www.ElectricalPartManuals.com](http://www.ElectricalPartManuals.com)

**E. INSTALLATION** The "LA" air circuit breaker is completely adjusted, tested, and inspected at the factory before shipment, but careful check should be made to be certain that shipment or storage has not resulted in damage or change of adjustment. Circuit breakers should be installed in a clean, dry, well-ventilated place in which the atmosphere is free from destructive acid or alkali fumes. Stationary-type breakers should be mounted high enough to prevent injury to personnel either from circuit interruption or from moving parts during automatic opening of the breaker. Allow sufficient space to permit access for cleaning and inspection and adequate clearance to insulating barrier above the breaker to prevent damage from arcing during interruption. Before installing, make certain that the breaker contacts are in the open position.

1. After the breaker is installed in position, close it manually by the maintenance closing method (See Section III) to check proper functioning of the mechanism and contacts. (CAUTION: MAKE SURE CIRCUIT IS NOT ENERGIZED). During the closing operation, observe that the contacts move freely without interference or rubbing between movable arcing contacts and parts of the arc chutes. Then refer to Section II of the Instruction Book for a detailed description of the circuit breaker operating characteristics before putting the breaker in service.
2. Trip units and accessory devices should receive a thorough check prior to placing the breaker in service to be certain that adjustments are proper and parts are not damaged.
3. Cubicle-mounted breakers of the drawout type are equipped with a draw-out interlock to prevent movement of a closed breaker into or out of the connected position. See Section II of the Instruction Book for a description of the interlock. Its operation should be checked before the breaker is energized.
4. Upon completion of the installation inspection, the breaker is ready to be energized after the control wiring, if any, is checked and the insulation tested.

**F. STORAGE** When breakers are not to be put into immediate use, they should be wrapped or covered with a non-absorbant material to provide protection from plaster, concrete dust or other foreign matter. Breakers should not be exposed to the action of corrosive gases or moisture. In areas of high humidity or temperature fluctuations, space heaters or the equivalent should be provided.

**G. MAINTENANCE** Occasional checking and cleaning of the breaker will promote long and trouble-free service. A periodic inspection and servicing at least every six months should be included in the breaker maintenance routine.

If the circuit breaker is not operated during extended periods, the breaker should not remain in either the closed or open position any longer than six months. Maintenance opening and closing operations should be made to ensure freedom of movement of all parts.

**H. RENEWAL PARTS** When ordering renewal parts, specify the complete name-plate data including breaker serial number.

[www.ElectricalPartManuals.com](http://www.ElectricalPartManuals.com)



[www.ElectricalPartManuals.com](http://www.ElectricalPartManuals.com)

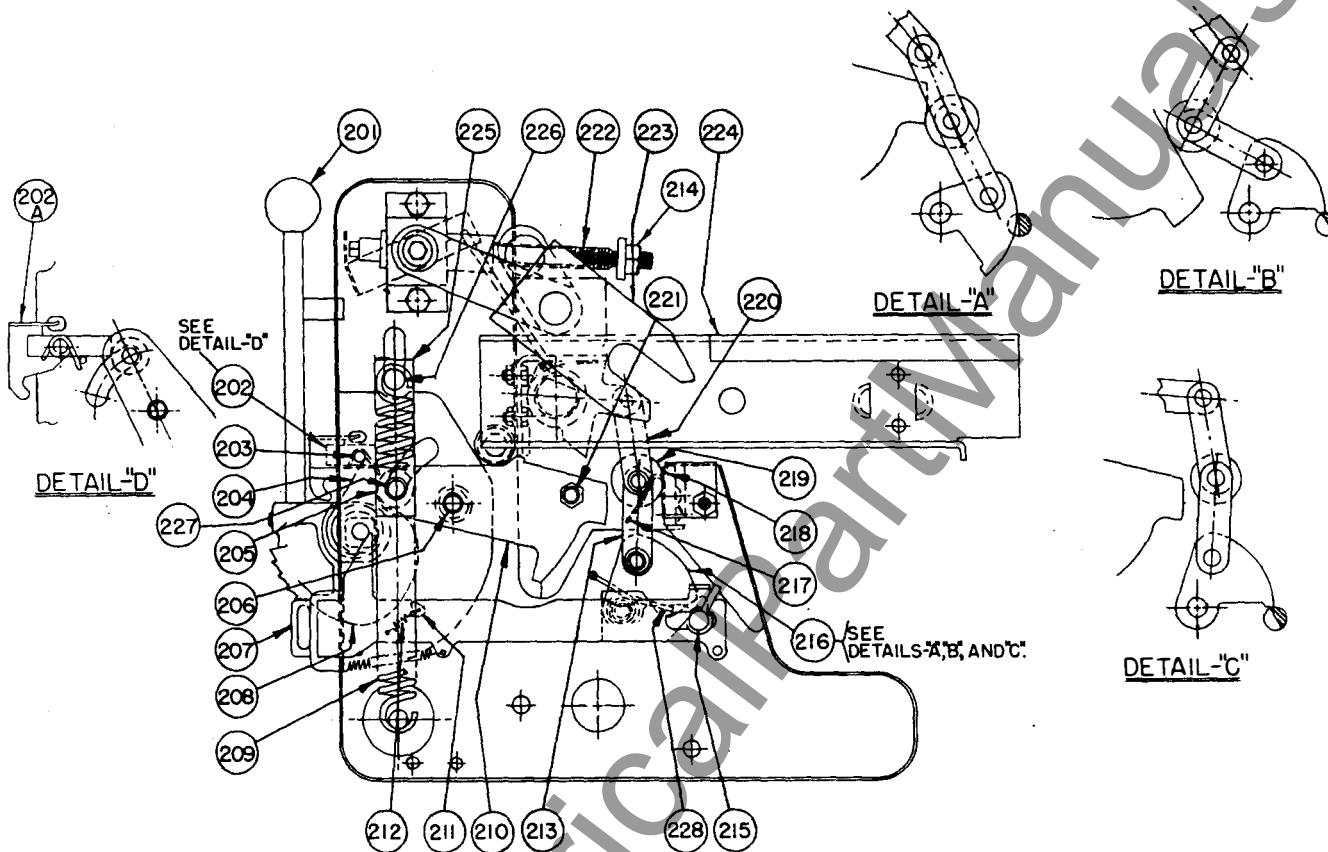

- 201. CLOSING HANDLE
- 202. SPRING RELEASE LATCH
- 202A. HOOD
- 203. SPRING
- 204. SPRING
- 205. ROLLER
- 206. PIN
- 207. TRIP ROD
- 208. CAM

- 209. SPRING
- 210. CLOSING CAM
- 211. PAWL
- 212. SPRING
- 213. TOGGLE LINKAGE
- 214. NUT
- 215. TRIP SHAFT
- 216. TRIP LATCH

- 217. SPRING
- 218. STOP
- 219. ROLLER
- 220. TOGGLE LINKAGE
- 221. SCREW
- 222. RACKING SCREW
- 223. CLEVIS
- 224. RAIL

- 225. LINK
- 226. PIN
- 227. PIN
- 228. SPRING

**FIG. 2**  
**TYPICAL OPERATING MECHANISM**  
**MANUALLY OPERATED BREAKER**  
 MARCH 2, 1967 72-340-014-401

**ALLIS-CHALMERS**

[www.ElectricalPartManuals.com](http://www.ElectricalPartManuals.com)

SECTION II. OPERATION

A. DESCRIPTION The LA-1600 air circuit breaker has an interrupting capacity of 50,000 amperes and a maximum continuous current rating of 1600 amperes at 600 volts, 60 cycles. For information on other voltages or frequencies, the factory should be consulted. It is available as a manually-operated breaker or an electrically-operated breaker. The two breakers are identical with the exception of the medium used to transmit power to charge the stored-energy springs.

A double-toggle, trip-free mechanism is used; that is, the breaker contacts are free to open at any time, if required, regardless of the position of the mechanism or the force being applied.

1. Manually-Operated Breaker

As the breaker has a single-frame type construction, most of the latches and linkages are arranged in pairs; however, for descriptive purposes, they will be referred to as single items. Refer to Figure 2. Detail "A" shows the position of trip latch (216) when the breaker contacts are open with the closing spring discharged. Movement of closing handle (201) downward rotates cam (208) against roller (205) thus pivoting closing cam (210) clockwise about pin (206) and extending stored-energy springs (209) through link (225) and pin (226). Rotation of cam (210) clockwise permits spring (217) to collapse toggle linkage (213) & (220). At the same time, trip latch (216) is reset by torsion spring (228) as shown in Detail "B". Pushing down spring release latch hood (202A) after the closing handle is returned to the normal vertical position, releases the energy in springs (209). Through link (225), closing cam (210) is rotated counterclockwise against roller (219) which moves toggle linkage as shown in Detail "C", to close the breaker contacts. The closing operation may be interrupted at any point by functioning of the trip device, thus ensuring "trip-free" operation.

To open the breaker contacts, trip rod (207) is actuated. This rotates trip shaft (215) clockwise which releases trip latch (216) as shown in Detail "A". On breakers equipped with a shunt trip device, the breaker contacts may be opened by operation of a remote trip control switch. The shunt trip device rotates the trip shaft to release the trip latch.

TABLE I	OPERATING PROCEDURE	MANUALLY-OPERATED BREAKERS
<u>CHARGING SPRINGS:</u>	Pull handle (201) down all the way (approximately 120°) and return to normal vertical position. (Engagement of pawl (211) with the ratchet teeth prevents handle reversal until the downward stroke is completed.)	
<u>CLOSING:</u>	Push down spring-release latch hood (202A) after handle is returned to normal vertical position.	
<u>TRIPPING:</u>	Push in manual trip rod (207).	
	OR	If shunt trip is provided, operate remote trip control switch (CST). (See Figure 3.)

[www.ElectricalPartManuals.com](http://www.ElectricalPartManuals.com)

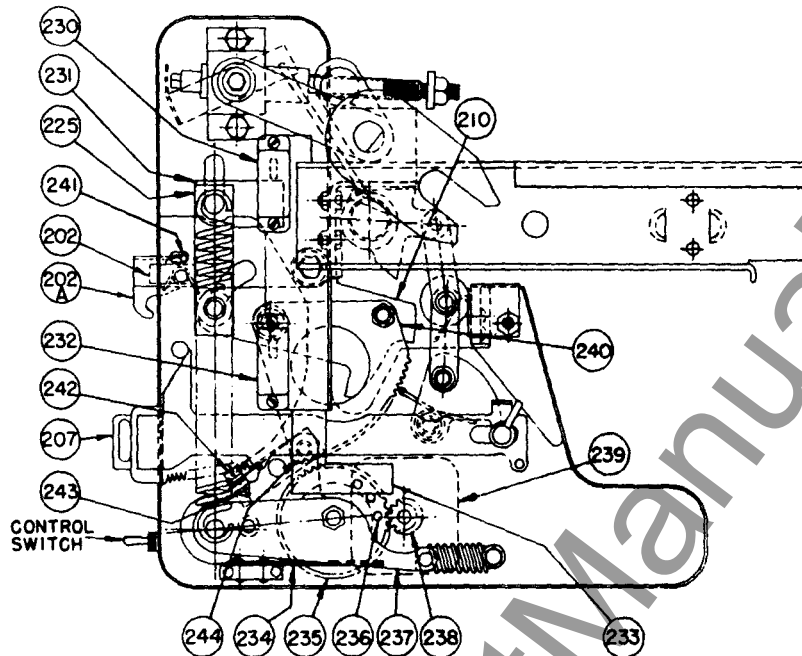

- |                             |                            |
|-----------------------------|----------------------------|
| 202. SPRING RELEASE LATCH   | 235. GEAR                  |
| 202A. HOOD                  | 236. PINS                  |
| 207. TRIP ROD               | 237. TOGGLE LINKAGE        |
| 210. CLOSING CAM            | 238. MOTOR GEAR-BOX PINION |
| 225. LINK                   | 239. MOTOR                 |
| 230. SPRING-POSITION SWITCH | 240. GEAR SEGMENT          |
| 231. ARM                    | 241. PIN                   |
| 232. MOTOR CUT-OFF SWITCH   | 242. SCREW                 |
| 233. PLUNGER                | 243. NUT                   |
| 234. FLAT SPRING            | 244. ROLLER                |

PAGE 6

WIND 3-6  
CLOSE 6-1  
TRIP 2-7  
TOGGLE SW =

**FIG. 2A**  
TYPICAL OPERATING MECHANISM  
ELECTRICALLY OPERATED BREAKER  
MARCH 11, 1967 72-340-018-401

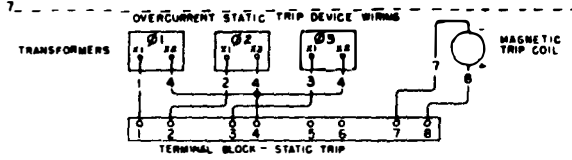
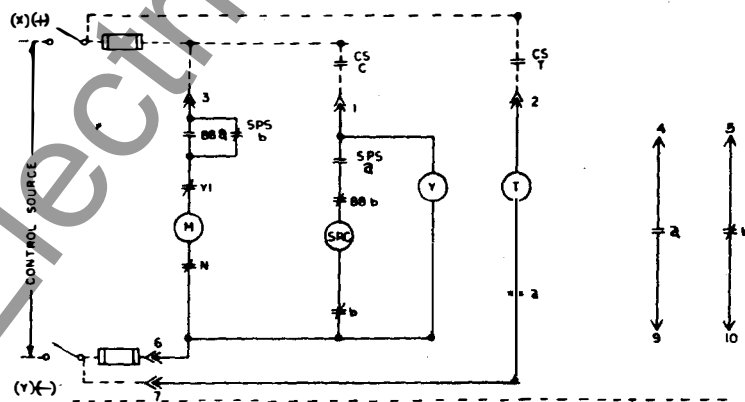

TYPICAL WIRING DIAGRAM FOR  
ELECTRICALLY OPERATED BREAKERS

[www.ElectricalPartManuals.com](http://www.ElectricalPartManuals.com)

2. Electrically-Operated Breaker The mechanism of the electrically-operated breaker is the same as that of the manually-operated breaker except that the manual closing handle is replaced by an electric motor and the gear system.

Refer to Figures 2A and 3. Movement of the control switch (N) located on the front of the breaker to the "ON" position, when the control circuit is energized, will start the automatic closing cycle. Motor gear box pinion (238) rotates gear (235) counterclockwise, and pins (236) move across the top of flat biasing spring (234). This raises toggle linkage (237) over center and positions gear (235) to mesh with gear segment (240). Since this gear segment is attached to closing cam (210), the stored-energy springs are charged and latched in the same sequence as described in the previous section. The lower extension of closing cam (210) engages a roller on toggle linkage (237) to disengage gear (235) from gear segment (240) after the stored-energy springs are latched in the charged position by spring-release latch (202).

Spring-position switch (230) (SPS b) is actuated to the open position by arm (231) attached to link (225) as the stored-energy springs approach the charged position. This switch initiates the spring recharging cycle and is connected in parallel with motor cut-off switch (232) (88a) which is open initially, closes while the motor charges the springs, and opens when the springs are charged with the gearing disengaged. The motor cut-off switch is actuated by the movement of plunger (233) over pins (236). Approximately twelve seconds are required for completion of the spring charging cycle.

The breaker may now be closed by pushing down spring-release latch hood (202A) as in the manually-operated breaker, or it may be closed electrically through remote close control switch (CSC). This switch energizes spring-release coil (SRC) which moves pin (241) in a counterclockwise direction to trip spring release latch hood (202A) and spring-release latch (202). The "Y" coil is energized simultaneously with the spring-release coil and causes the "Y" contact to open the circuit to the motor. Since the "Y" relay will remain energized as long as the remote close control switch (CSC) is held closed, "Y" contact keeps the motor circuit open to prevent "pumping" or repeated attempts to charge the stored-energy springs when the breaker is closing.

After the stored-energy springs are discharged, they are automatically recharged as long as the control circuit is energized, and the control switch (N) is in the "ON" position. Figure 3 shows the spring-position switch (SPS b) closed to complete the motor control circuit as it would be when the springs are discharged.

TABLE 2	OPERATING PROCEDURE	ELECTRICALLY-OPERATED BREAKERS
<u>Charging Springs:</u>	Energize control circuit. Move control switch (N) on front of breaker to "ON" position.	
<u>Closing:</u>	After springs are charged, actuate remote close control switch (CSC).	
	OR	Push down spring-release latch hood (202A).
<u>Tripping:</u>	Actuate remote trip control switch (CST).	
	OR	Push in manual trip rod (207).

[www.ElectricalPartManuals.com](http://www.ElectricalPartManuals.com)

# ALLIS-CHALMERS

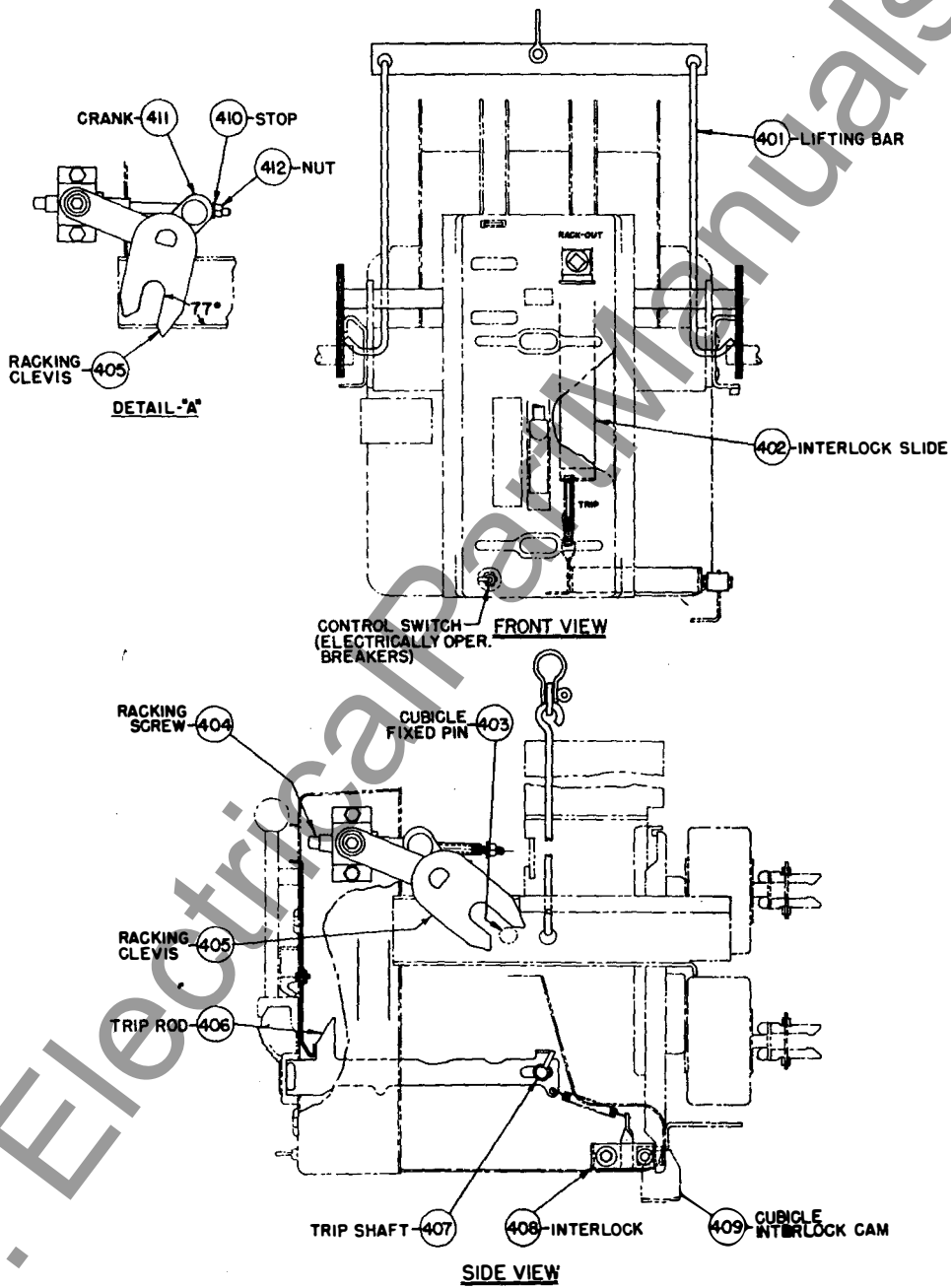

**FIG.4**  
TYPICAL RACKING MECHANISM  
& DRAWOUT INTERLOCK  
APRIL 3, 1967 72-4 40-010-401

[www.ElectricalPartManuals.com](http://www.ElectricalPartManuals.com)

B. RACKING MECHANISM, DRAWOUT INTERLOCK, AND LIFTING BAR. Cubicle-mounted breakers of the drawout type include as integral parts the mechanism to rack the breaker in and out of the cubicle compartment, the drawout trip interlock and the drawout position markings.

Refer to Figure 4. Lifting bar (401) may be used to lift the breaker when it is being inserted in the cubicle.

With the breaker in position on the rails, the following sequence should be used to rack the breaker into the fully connected position.

ON ELECTRICALLY-OPERATED BREAKERS, BE CERTAIN THAT THE CONTROL SWITCH ON THE FRONT OF THE BREAKER IS IN THE "OFF" POSITION.

1. Lower the interlock slide (402) to expose racking screw (404). (Lowering the interlock slide will actuate trip rod (406) to trip a closed breaker.) While the interlock slide is in this position, the breaker is "trip-free" and cannot be closed.
2. With the switchgear operating crank, rotate racking screw (404) to move racking clevises (405) to the position shown where they will engage with fixed pins (403) in the cubicle.
3. The breaker should now be pushed along the rails to the "DISCONNECTED" position. At the same time the racking clevises (405) should be checked to see that they are in correct alignment with cubicle fixed pins (403).

Counterclockwise rotation of the operating crank will now rack the breaker into the "TEST" and connected positions. At the "TEST" and connected positions, interlock (408) is in its normal horizontal position. By removing operating crank and then raising interlock slide (402), trip rod (406) returns to the extended position permitting trip shaft (407) to reset and the breaker may be operated.

Between "TEST" and connected positions, the cubicle interlock cam (409) raises interlock (408) to hold trip rod (406) and trip shaft (407) in the "trip-free" position so that the breaker cannot be closed even if interlock slide (402) is raised. This is to prevent movement of a closed breaker into or out of the connected position.

4. To withdraw the breaker from the connected position, the procedure is the same except that the direction of rotation of the operating crank is clockwise.
5. If necessary to adjust racking screw stop (410) rotate racking screw (404) until racking clevis (405) reaches the 77° position as shown (Detail "A"). Position stop (410) against crank (411) with nut (412).

**CAUTION:** TO AVOID DAMAGE TO THE RACKING MECHANISM, DO NOT ROTATE THE OPERATING CRANK IN THE COUNTERCLOCKWISE DIRECTION AFTER THE BREAKER HAS REACHED THE FULLY CONNECTED POSITION.

[www.ElectricalPartManuals.com](http://www.ElectricalPartManuals.com)

C. SPRING DISCHARGE MECHANISM (Fig. 2) (Fig. 17)

1. Description and Function When racking circuit breaker OUT of cubicle (see Section 11B) the stored energy closing springs (209) will automatically discharge prior to, or when circuit breaker reaches the disconnect position.

This is accomplished by the following sequence:

- a) Lever (1701) rotates clockwise during RACKOUT allowing roller (1702) on lever (1701) to rotate cam (1703) counterclockwise.
  - b) Cam (1703) moves rod (1704) upward which in turn rotates lever (1705) clockwise.
  - c) Lever (1705) in turn rotates spring release latch (1713) clockwise allowing the stored energy closing springs (209) to discharge.
  - d) When roller (1702) strikes cam (1703) and stored energy springs discharge cam (1703) must snap back into reset position prior to or when circuit breaker reaches the DISCONNECT position.
2. Adjustments (Fig. 1) (Fig. 2) (Fig. 17)

If adjustment becomes necessary the following procedure will be required:

- a) Remove cover (126).  
**CAUTION:** With cover removed and circuit breaker contacts open the circuit breaker will CLOSE when the stored energy springs are discharged automatically.
- b) Align center punch mark on trunion (1706) with center punch mark (test position) on arm (1707).
- c) Remove cotter pin (1710), remove washers (1711), remove rod (1704) from cam (1703), adjust rod (1704) by screwing into or out of yoke (1712) until the nominal .375 dimension is obtained between the end of rod (1704) and inside of yoke (1712). Insert rod (1704) into cam (1703), replace washers (1711), insert cotter pin (1710) and bend.
- d) Charge stored energy springs (209) then rotate racking screw (222) in the clockwise direction (see Section 11B). The stored energy closing springs should automatically discharge prior to or when circuit breaker reaches the DISCONNECT position. Cam (1703) must snap back to reset position as shown. (See Section 1 (d) above).
- e) If the stored energy closing springs DO NOT automatically discharge as described in Section 2 (d):
  1. Repeat Step 2 (b).
  2. Readjust as necessary per Section 2 (c) within the prescribed tolerance limits of  $.375 \pm .062$ .
- f) Repeat Step 2 (d).

[www.ElectricalPartManuals.com](http://www.ElectricalPartManuals.com)

### SECTION III. MAINTENANCE AND ADJUSTMENTS

A. MAINTENANCE Occasional checking and cleaning of the breaker will promote long and trouble-free service. A periodic inspection and servicing at intervals of six months or one year should be included in the maintenance routine. Circuit breakers located in areas subject to acid fumes, cement dust, or other abnormal conditions, require more frequent servicing. After a severe overload interruption, the breaker should be inspected.

If the circuit breaker is not operated during extended periods, it should not remain in either the closed or open position any longer than six months. Maintenance opening and closing operations should be made to ensure freedom of movement of all parts.

A suggested procedure to follow during maintenance inspections is given below:

1. De-energize the primary and control circuits.
2. Rack cubicle-mounted breakers of the drawout type to the disconnected position.
3. Discharge stored-energy springs.
4. Remove arc chutes and examine for burned, cracked, or broken parts.
5. Wipe the contacts with a clean cloth saturated with a non-toxic cleaning fluid.
6. Replace badly burned or pitted contacts. (See paragraph E).
7. Wipe all insulated parts with a clean cloth saturated with a non-toxic cleaning fluid.
8. Bearing pins and other sliding or rotating surfaces should be cleaned and then coated with a light film of grease (See paragraph B).
9. Operate the breaker manually in maintenance closing position (see paragraph C) to check latch and linkage movement.
10. Check breaker adjustments (see paragraph D).

B. LUBRICATION Lubrication should be a part of the service procedure. Needle bearings are packed with grease and should require no further attention. Old grease should be removed from bearing pins and other rotating or sliding surfaces, and they should be wiped with a thin film of petroleum-oil-base precision-equipment grease similar to BEACON P-290. Greasing should be done with care because excess grease tends to collect foreign matter which in time may make operation sluggish and may affect the dielectric strength of insulating members.

[www.ElectricalPartManuals.com](http://www.ElectricalPartManuals.com)

# ALLIS-CHALMERS

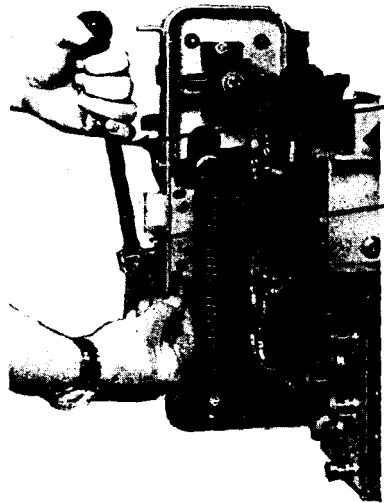

(REFER SECTION 111C PG. 7)

MAINTENANCE CLOSING HANDLE

RELEASE LATCH HOOD

205429

TYPICAL  
MAINTENANCE CLOSING HANDLE  
ELECTRICALLY OPERATED BREAKERS

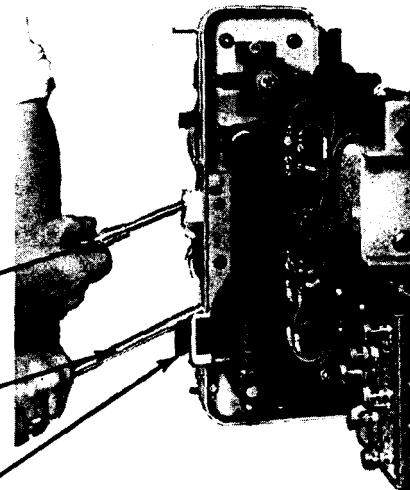

STEP 1

STEP 2

MANUAL TRIP ROD

205430

TYPICAL  
MAINTENANCE CLOSING HANDLE  
PROCEDURE

(REFER FIG. 2 DETAIL "D")

(REFER TABLE 3, PG. 7)

FIGURE 5

MAINTENANCE CLOSING

[www.ElectricalPartManuals.com](http://www.ElectricalPartManuals.com)

C. MAINTENANCE CLOSING: During inspection prior to installation and for routine maintenance inspections, the breaker contacts may be closed slowly to check clearances, contact adjustments, and movement of links and latches. The manual closing handle is used for maintenance closing the breaker.

Electrically-operated breakers do not have a manual closing handle, but a manual closing handle-cam assembly is available as a maintenance item. Figure 5 shows the maintenance closing handle being inserted in an electrically-operated breaker after removal of the front cover from the breaker. When the hole in the maintenance closing handle assembly is aligned with the holes in the operating mechanism frame, the pin which is attached to the chain is inserted. This pin holds the assembly in place and acts as a pivot point for the cam.

After insertion of the maintenance closing handle assembly on the electrically-operated breaker, the actual maintenance closing operation is the same for both the electrically-operated breaker and the manually-operated breaker. Refer to Table 3 and Figure 5.

TABLE 3	MAINTENANCE CLOSING
<u>CLOSING CONTACTS:</u>	<ol style="list-style-type: none"> <li>1. Place blade of screwdriver between hood and spring release latch. Push down spring release latch and hold it in this position.</li> <li>2. Pull closing handle DOWN ALL THE WAY (approximately 120°) and SLOWLY return to normal vertical position.               <ol style="list-style-type: none"> <li>a) Contacts will close to arcing contact touch position, but breaker will not close completely.</li> </ol> </li> </ol>
<u>OPENING CONTACTS:</u>	<ol style="list-style-type: none"> <li>1. Push in manual trip rod.</li> </ol>

CAUTION: THE ABOVE PROCEDURE SHOULD BE USED FOR MAINTENANCE CLOSING ONLY.

NOTE: Holding the spring release latch down prevents the stored-energy springs from propping in the charged position. Thus when the handle is slowly returned to the normal vertical position, the energy in the springs is slowly released against the closing handle assembly cam face.

D. ADJUSTMENTS: During maintenance inspections, the following items should be checked to ensure that the original settings are maintained:

[www.ElectricalPartManuals.com](http://www.ElectricalPartManuals.com)

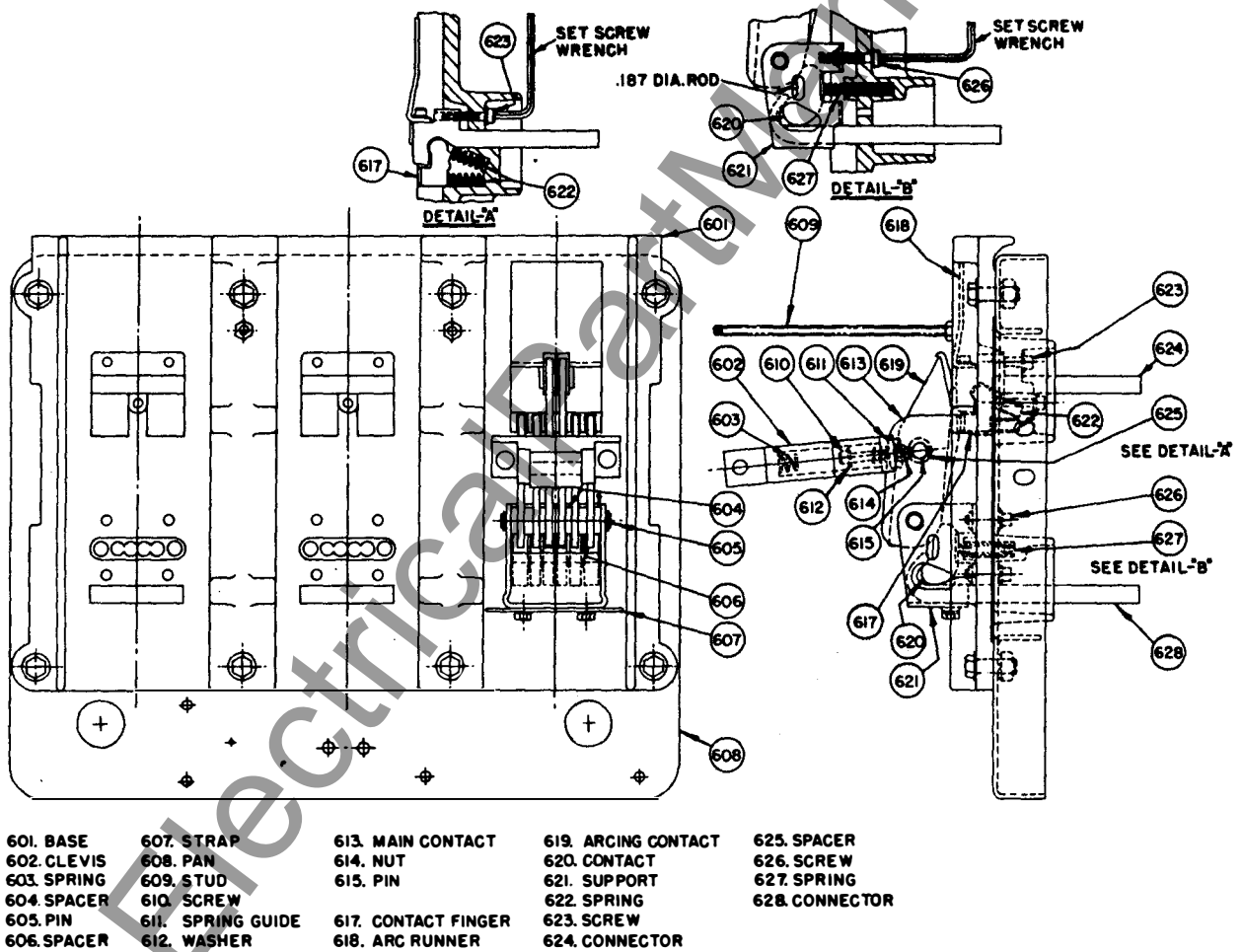

**FIG.6**  
**TYPICAL PANEL ASSEMBLY**  
MARCH 8, 1967 72-340-021-401

[www.ElectricalPartManuals.com](http://www.ElectricalPartManuals.com)

1. Trip Latch Engagement (Refer to Figure 2)

Trip latch (216) should have an engagement of .062" plus or minus .015" on trip shaft (215). Measurement is made with the latch resting on the shaft in the reset position.

2. Main Contact Make (Refer to Figure 6)

Compression of contact fingers (617) should be between .093" and .125". This is the difference in the measurement from the breaker base to the center of the finger contact surface when the breaker is open and the measurement in the same place when the breaker is closed. This is checked with a normal closing operation - not maintenance closing. Adjustment is provided by positioning screws (610) after loosening nuts (614). Counterclockwise rotation of screws (610) increases compression. Care should be taken to re-tighten nuts (614) after adjustment. If it is desired to check contact pressure, a push-type spring scale can be used to compress contact fingers (617) with the breaker open. Contact pressure should be between 20 and 30 pounds.

3. Arcing Contact Make (Refer to Figure 6)

With movable arcing contact in any one phase touching the mating stationary contact when the breaker is closed by the maintenance closing method (see Table 3), the phase to phase variations should not exceed .062". Adjustment may be made by positioning screws (610) as in paragraph 2, but it is essential that the main contact compression be maintained within the tolerance listed in paragraph 2. Arcing contact pressure can be checked with the breaker contacts closed by pulling both contacts at the base of the arcing contact tip insert with a pull-type spring scale until contacts part. The contact pressure should be between 70 and 80 pounds.

4. Electrically-Operated Breakers (Refer to Figures 2A & 3)

a) Motor-Cut-Off Switch and Spring-Position Switch

These switches are mounted on a common bracket that is set and roll-pinned in position during production testing. If replacement is required, the bracket must be positioned so that when roll pins (236)

[www.ElectricalPartManuals.com](http://www.ElectricalPartManuals.com)

in gear (235) are at the top position, they have moved plunger (233) against the roller of motor cut-off switch (232) to shut off the motor. As the springs are charged, arm (231) must engage the roller of spring-position switch (230). Pilot holes are provided in the mounting bracket for drilling and roll-pinning the replacement assembly in the correct position.

b) Gear Toggle Linkage - Refer to Figure 2A

On LA-1600 breakers, provisions are made for adjusting the precise position where the gear toggle linkage disengages from the gear segment. This is set during production testing, but the following method may be used for readjustment. Tighten screw (242) and nut (243) to raise roller (244) slightly so that when the breaker is operated electrically, spring release latch (202) does not prop the needle bearing of closing cam (210) in the spring charged position. When this occurs, the breaker main movable contacts will close automatically. From this position of the screw, nut and roller, loosen the screw to lower the roller to the point where the spring release latch will prop the closing cam needle bearing in the spring charged position. During this adjustment sequence, breaker operation should be controlled by means of the toggle switch on the front of the breaker.

E. CONTACT REPLACEMENT - Refer to Figure 6. The contact structure consists of main current carrying contacts and arcing contacts arranged so that initial contact make and final contact break is by means of the arcing contacts. The main contacts are not subject to arcing. The actual contact surfaces are clad with an alloy facing which greatly reduces mechanical wear and arc erosion.

When inspection of the alloy facing indicates that the contacts should be replaced, it should be noted that hinge contact fingers (620), main contact fingers (617) and arcing contacts (619) are spring loaded. Therefore, extreme care must be exercised in removal and installation of any of the contacts.

1. Main Contact Fingers

With the breaker contacts open and the stored-energy springs discharged, main contact fingers (617) may be removed by loosening screws (623) enough to relieve the compression on springs (622) as shown in Detail "A". There are two springs behind each finger and it is important that they be positioned properly upon reinstallation. If difficulty is experienced in correctly positioning these springs, the upper and lower primary disconnects (119 - Figure 1) may be removed from each phase and the breaker inverted to rest on the ends of connectors (624) and (628).

After the contact fingers are replaced, connector (624) should be positioned in the center of the slot in the molded base to assure correct alignment of the primary disconnect fingers.

[www.ElectricalPartManuals.com](http://www.ElectricalPartManuals.com)

2. Stationary Arcing Contact

The stationary arcing contact is a part of connector (624) and may be replaced by proceeding as above. In this case, screws (623) must be removed. However, to provide a clearance for removal of connector (624), first insert a .187" diameter rod at least 3" long through the opening in support (621) as shown in Detail "B". This will hold hinge contact fingers (620) in position to permit removal of pin (605). It may be necessary to compress contacts (620) opposite arcing contacts (619) in order to insert the rod. (As an aid in holding spacers (604) and (606) in their correct positions, withdrawal of pin (605) can be followed by the insertion of a shorter pilot pin to permit removal of the complete movable contact assembly as a group from support (621). The pin at the end of clevis (602) should then be removed so that the complete movable contact assembly can be positioned or removed to provide clearance for removal of connector (624).

3. Hinge Contact Fingers

Hinge contact fingers (620) may be removed as follows: Remove top screws (626) from support (621) and replace them with two .250-20 screws at least 1.5" long. Remove lower screws (626) and then gradually back off the 1.5" screws as shown in Detail "B", to relieve the loading from springs (627). The hinge contact fingers can now be removed. Be certain to replace the 1.5" long screws with the original screws after replacement of the contact fingers.

4. Moving Arcing and Main Contact

Either moving arcing contact (619) or main contact (613) or both, may be removed and replaced as follows: Follow the steps outlined in paragraph 3 or if hinge contact fingers are not to be replaced, omit these steps and refer to paragraph 2. Disregard the reference to the removal of screws (623) and the removal of connector (624) in paragraph 2. Then remove the complete movable contact assembly as outlined.

Because arcing contacts (619) are heavily spring loaded, it is suggested that an arbor press or the equivalent be used to disassemble or assemble the movable contacts. Parallel blocks of wood should be used to position and hold clevis (602) firmly while removing screws (610) from pin (615). To minimize adjustment upon reassembly, the position of the two screws (610) relative to pin (615) should be noted. The location of spacers (604), (606) and (625) should also be noted. Then the two elastic stop nuts (614) should be loosened and screws (610) backed off far enough to remove them from pin (615).

**CAUTION: EXTREME CARE SHOULD BE TAKEN TO HOLD THE ASSEMBLY FIRMLY TO RETAIN SPRING GUIDE (611) AND SPRINGS (603) UPON REMOVAL OF THE SCREWS.**

The moving arcing contacts or the main contacts may now be replaced. The reverse procedure is followed for reinstallation. Be certain that both springs (603) are placed in the clevis behind spring guide (611). Care should be taken to replace spacers (604), (606) and (625) correctly. Check alignment and adjustment of contacts upon reassembly.

[www.ElectricalPartManuals.com](http://www.ElectricalPartManuals.com)

## SECTION IV. STATIC OVERCURRENT TRIP DEVICE

A. INTRODUCTION The Allis-Chalmers Static Overcurrent Trip Devices are completely static; that is there are no moving parts or contacts. The circuits of the device are designed for light loading of components and are temperature compensated for accuracy and stability of calibration over wide temperature ranges for indefinite periods of time. The static overcurrent trip devices, which replace the electro-mechanical series overcurrent trip devices, perform the same function with a higher degree of accuracy and versatility. In common with series overcurrent trip devices, all energy for operation is obtained from overload or fault current. No batteries or other external power sources are required.

The complete static overcurrent trip system consists of three current transformers, one per phase, mounted on the circuit breaker primary connectors, a release magnet, and the static overcurrent trip device. This system operates to trip the circuit breaker when a system overload condition exceeds a pre-selected value of current. Tripping will occur after a predetermined time delay or instantaneously depending upon the adjustment selected and the magnitude of the overload.

The static trip device contains three current transformers which provide a small low voltage secondary current proportional to the circuit breaker primary current. The secondary of each transformer is connected in series with a power supply transformer and an auxiliary transformer. The output of the power supply transformers is rectified to provide D.C. energy to the release magnet trip coil and also a regulated D.C. power supply to operate transistor circuits. Potentiometers or rheostats connected in parallel with the auxiliary transformers provide an A.C. signal voltage proportional to the primary current. This acts as the intelligence input for the device, and the magnitude of this A.C. voltage determines whether or not the breaker will trip and the time delay before tripping. The relation between this A.C. signal voltage and the primary current can be varied by adjusting the potentiometers to set the minimum primary current at which tripping will occur. This is the pick-up adjustment.

A transistor trigger circuit prevents operation of the timing circuit unless the signal exceeds 95% of pick-up value. If the trigger has operated, a capacitor will charge gradually to a voltage which causes the static switch to operate, energize the trip coil, and trip the breaker. If at any time before the static switch actually operates, the primary current decreases to 95% or less of the set pick-up, the trigger will turn off and reset will take place.

Some minor variations in pick-up and time delay may be expected with temperature fluctuations from an ambient of  $-40^{\circ}\text{C}$ . to an ambient of  $55^{\circ}\text{C}$ .

A typical breaker rating plate is shown in Figure 7A. The maximum rated amperes is determined by the current transformers mounted on the circuit breaker primary connectors. The maximum current available is limited by the circuit breaker frame size. Since the static overcurrent trip device components are calibrated in terms of transformer secondary current, the same device can be used with any of the groups of current transformers available.

[www.ElectricalPartManuals.com](http://www.ElectricalPartManuals.com)

**B. DESCRIPTION OF STATIC TRIP DEVICES** These instructions describe four models of static trip devices. All are similar in many respects and differ only in the kind of end use function that they provide. All use the same current transformer inputs and provide output signals to the magnetic latch release as previously described.

**Dual Model A1**

Furnished with one non-adjustable current-time curve. The curve may be either for the minimum, the intermediate, or the maximum curve as shown in Figure 7E. Time delay up to fifteen times pick-up is standard, as is instantaneous tripping between five and fifteen times pick-up by adjustment. It monitors the current in each of the three phases.

**Dual Model AG**

Same as the Model A1 except that the circuit is arranged to monitor current in two phases and current in the neutral of the primary current transformers. This device is thus able to provide normal overload and short circuit protection, and also to detect ground fault currents as low as 20% of the current required to operate the phase circuits.

**Selective Model D**

This static overcurrent trip device is furnished with three long time delay curves and three short time delay curves, any combinations of which may be selected by settings on the front plate of the device. Selectivity between coordinated circuit breakers can be maintained throughout the full interrupting range of the circuit breakers. The Model D device monitors the currents in each of the three phases. The arrangement of the current-time curves is shown in Figure 7D.

**Selective Model DG**

Same as the Model D except that the circuit is arranged to monitor current in two phases and current in the neutral of the primary current transformers. This device is thus able to provide normal overload and short circuit protection, and also to detect ground fault currents as low as 20% of the current required to operate the phase circuits.

Throughout the text any reference to static trip device -

- A-1 is also applicable to A-2
- AG is also applicable to AG-1
- D is also applicable to D-1

**I. SELECTION OF SETTINGS**

The static overcurrent trip devices have a number of knobs and switches which can be arranged to select the specific conditions that will cause the circuit breaker to open. The selection of settings is usually made when the circuit breaker is placed in service, and will not require later changes unless load condition or other primary circuit changes are made. The following paragraphs describe the various selections that may be made.

[www.ElectricalPartManuals.com](http://www.ElectricalPartManuals.com)

**CAUTION:** ALL SELECTION KNOBS ARE EQUIPPED WITH SHAFT LOCKS TO ENSURE PERMANENCE OF SETTINGS. TURNING A KNOB ON A LOCKED SHAFT WILL CAUSE LOSS OF CALIBRATION. THE SECTION ON MAINTENANCE DESCRIBES HOW TO RESTORE CALIBRATION IF THIS SHOULD HAPPEN.

### **Pick-Up Selection**

The three knobs arranged vertically on the right hand side of the static trip device (Figure 7) are for selection of the current at which a time delay tripping operation will start. This is the pick-up current. One knob is provided for each phase (except Models AG, DG, where the middle knob is used to select ground current pick-up).

The pick-up selection dials are marked with the letters 'A' through 'E'. The pick-up current defined by each letter is listed on the circuit breaker rating plate (Figure 7A). This is the minimum primary circuit current which will cause the circuit breaker to open.

**EXAMPLE:** A circuit breaker has a rating plate as shown in Figure 7A. The pick-up settings are at point 'A'. Therefore, the circuit will carry up to 500 Amps without tripping the circuit breaker. Above 500 Amps a trip operation will occur.

The pick-up selection is continuous and may be set between marks if desired. Usual practice is to set all pick-up knobs at the same mark, but this is not necessary and different phases can have different pick-up settings.

The rating of the circuit breaker depends solely on the primary current transformers selected for the application, and is limited only by the circuit breaker frame size. The rating of a circuit breaker may be changed if desired merely by replacing the current transformers and the breaker rating plate. Nothing changed on the static trip device or other breaker components. Figure 7A shows breaker ratings available with various current transformers.

**EXAMPLE:** The breaker represented by the rating plate in Figure 7A is changed to have 1600 maximum rated Amps (thus A = 800, B = 1000, C = 1200, D = 1400, E = 1600). The pick-up settings are still on 'A'. The circuit will now carry up to 800 Amps and will trip on anything above 800 Amps in the primary circuit.

[www.ElectricalPartManuals.com](http://www.ElectricalPartManuals.com)

### Ground Pick-up Selection

Models AG, DG. The middle knob on the right hand side of the Models AG, DG, is used to select the sensitivity of ground current detection. It is calibrated as a percentage of the MINIMUM available pick-up current shown on the breaker rating plate (Figure 7A). It does not have any relationship to the pick-up current selected for the phase settings. Calibrations are marked at 20, 40, 60, 80% but adjustment is continuous.

**EXAMPLE:** 1. A circuit breaker has a rating plate per Figure 7A. The pick-up settings are on "C" to select 750 Amps pick-up. The ground pick-up is set at 40%.

The ground current that will cause tripping is therefore not less than 40% of 500 Amps, or 200 Amps.

**EXAMPLE:** 2. Same conditions except pick-up settings are on "E" to select 1000 Amps pick-up.

The ground current pick-up is still 200 Amps, based on the minimum available pick-up of 500 Amps.

Ground current pick-up is treated in the same manner as phase current pick-up when using the current-time curve, and the same curve (Figures 7D and 7E) is used for defining time delay.

**EXAMPLE:** 3. Breaker rating per Figure 7A. Phase pick-up setting "E" (1000 Amps). Ground pick-up setting 40% (200 Amps). An actual ground current of 800 Amps is flowing.

800 Amps ground current is four times (4X) pick-up and will cause a trip operation in four and one-half seconds (on the minimum time band) as shown on the current-time curve (Figure 7E). However, this ground current is much less than the phase pick-up setting, and would not be recognized on the phase pick-ups.

For the LA-1600 Circuit Breaker:

- a) The lower limit of ground fault recognition on the Model AG static trip device is 40 Amps ground current. Primary current transformers that provide a MINIMUM CONTINUOUS CURRENT SETTING OF LESS THAN 200 AMPS should not be used for ground fault detection.
- b) The lower limit of ground fault recognition on the Model DG static trip device is 80 Amps ground current. Primary current transformers that provide a MINIMUM CONTINUOUS CURRENT SETTING OF LESS THAN 400 AMPS should not be used for ground fault detection.

### Instantaneous Trip Selection

Models AI and AG. The knob on the lower left selects a current value above which tripping takes place instantaneously instead of on time delay. The calibration is marked in multiples of pick-up and allows selection between five times (5X) and fifteen times (15X) pick-up. It is thus dependent on the settings selected for phase pick-up (as well as ground pick-up on the Model AG). The current-time curve (Figure 7E) shows how the time delay will follow the appropriate time band curve until the instantaneous setting is reached, then will go to the instantaneous value for all currents above that setting.

[www.ElectricalPartManuals.com](http://www.ElectricalPartManuals.com)

**EXAMPLE:** Breaker rating as per Figure 7A. Phase pick-up setting "E" (1000 Amps). Instantaneous setting 10X (10,000 Amps).

Currents above 10,000 Amps will cause instantaneous tripping to occur; currents below 10,000 Amps will follow the appropriate time delay curve.

**EXAMPLE:** Breaker rating as per Figure 7A. Phase pick-up setting "E" (1000 Amps). Ground pick-up setting 40% (200 Amps). Instantaneous setting 10X.

In this example using a Model AG, the breaker will trip without time delay if the phase current exceeds 10,000 Amps, or if the ground current exceeds 2000 Amps.

### **Time Band Selection**

The time bands on the Model AI and AG are set during manufacture and cannot be changed. The legend on the upper left corner of the static trip device indicates whether the particular device is set for MINIMUM, INTERMEDIATE, or MAXIMUM TIME BAND, corresponding to the curves on Figure 7E.

The Models D, DG, are arranged so that any of the time bands may be selected as desired. Also, there are two groups of time bands provided; one for long time delay and one for short time delay, corresponding to the curves on Figure 7D.

The knob at the middle of the left side on the Models D, DG front plate is a three-position switch marked to indicate LONG TIME BAND SETTING. The three positions provide for selection of a MINIMUM, INTERMEDIATE, or MAXIMUM TIME BAND, as shown in Figure 7.

The knob at the upper middle of the Models D, DG front plate provides for selection of either a MINIMUM, INTERMEDIATE, or A MAXIMUM SHORT TIME BAND setting.

The two groups of time bands are independent of each other. Any long time band can be selected to work with any short time band.

### **Transfer to Short Time Selection**

Models D, DG. The knob at the lower middle of the Models D, DG front plate selects the value of primary current above which the time delay will follow the selected short time band. It is calibrated in multiples of the selected phase pick-up current. Markings are provided at 5, 10, 15 and 20 times pick-up. The primary current value of this adjustment depends on the phase pick-up setting that has been selected.

[www.ElectricalPartManuals.com](http://www.ElectricalPartManuals.com)

**EXAMPLE:** Breaker rating as per Figure 7A. Phase pick-up settings "A" (500 Amps). Long time band setting is on MAXIMUM. Short time band setting is on MINIMUM. Transfer to short time is set at 10X.

Currents between 500 Amps and 5000 Amps will trip the breaker after a time delay defined by the maximum long time curve (Figure 7D). Currents above 5000 Amps will trip the breaker in the time indicated by the minimum short time curve.

If the phase pick-up settings were changed to "B" (625 Amps), then the short time band would be used for currents of 6250 Amps and above.

[www.ElectricalPartManuals.com](http://www.ElectricalPartManuals.com)

## 2. MAINTENANCE AND TESTING

### Maintenance

Each static overcurrent trip device is adjusted, calibrated, and tested before shipment and is ready for use after selecting appropriate settings and locking the potentiometer shafts.

Maintenance in the usual sense of clean, readjust, lubricate, etc. is not required on static overcurrent trip devices. The only maintenance that is recommended is periodic verification that the device is functioning. This may be supplemented as desired by checking the calibration, inspection for loose or broken external wiring, restoring lost calibration, etc.

### Restoring Lost Calibration

The calibration of the static overcurrent trip device depends on the knobs being properly oriented on their shafts. If the knobs are forced by neglecting to loosen the shaft locks, calibration will be lost, but can readily be restored.

A knob will be in proper calibration if, when turned counterclockwise as far as it can go, the pointer lines up precisely with the red calibration dot on the dial. Refer to Figure 7B.

If the above check shows the calibration to be in error, remove the knob by loosening its set screw and slipping it off the shaft. Then be sure the shaft lock is loosened (see Figure 7B) and turn the shaft counterclockwise as far as it will go. Keep the shaft in that position and replace the knob so that it is directly over the red calibration dot. Tighten the set screw in the knob.

With the shaft lock loosened, the knob may now be turned to the selected dial position, the shaft locked, and the device returned to service.

### Testing

The testing of Allis-Chalmers static overcurrent trip devices is easily accomplished under field conditions with a minimum of equipment and preparation. Various tests can be made, and in a manner that makes them suitable for use during routine maintenance. Calibration cannot normally be done under field conditions.

The tests that will be described can be done on a complete breaker assembly located in the disconnect position in the cubicle, on the complete breaker on a work table, or on a static trip device completely removed from the breaker. It is not necessary to remove permanent wiring in order to make tests. Testing can be done on a breaker exactly as it is used in normal service.

### Test Equipment

Simple, readily available equipment is used in the testing of static overcurrent trip devices. The following items of equipment are required for performing the routine FUNCTION Test.

[www.ElectricalPartManuals.com](http://www.ElectricalPartManuals.com)

1. A 115 VAC variable voltage transformer with at least 3 Amps output.
2. An ammeter which will indicate 1 to 3 Amps with reasonable accuracy.
3. An air-core reactor of 35 milli-henries or more with a DC resistance of 20 ohms or less. A standard 125 V DC power circuit breaker solenoid trip coil (such as Allis-Chalmers No. 71-200-745-501) may be used, as may other similar coils. However, a reactor designed for the purpose is available, and is also suitable for the more accurate requirements of time delay testing. It may be ordered as - REACTOR, 71-142-395-501.

Allis-Chalmers can also supply a complete, integrated and easily portable test set comprising essentially the above equipment, as illustrated in Figure 7C. Contact the local Allis-Chalmers office for further information.

#### Test Procedures

This section will describe in detail the steps to be taken to carry out the tests. Tests may be conducted on the complete circuit breaker, either in the disconnected cubicle position, or removed from the cubicle. It is not required to remove or disconnect any permanent wiring on the circuit breaker as long as primary and control circuits are not connected to the breaker. It will usually be advantageous to perform normal routine maintenance on the circuit breaker before testing the static trip device.

Although the following descriptions relate to a complete circuit breaker unit, it will be apparent that the tests can also be carried out on a static trip device by itself.

Connect a 100 ohm, 1 watt resistor across terminals 7 and 8 of the static trip device when the circuit breaker tripping device (see Figure 8) is not connected to the static trip, to simulate a load during this test.

[www.ElectricalPartManuals.com](http://www.ElectricalPartManuals.com)

Function Test - Proceed as follows:

Connect test circuit as shown in Figure 7F  
Loosen shaft locks  
Set pick-up knobs at "A"  
Set instantaneous (or transfer) knob at 10X or higher  
Close Breaker  
Quickly increase current to 1.5 Amps (3X pick-up) and hold  
Breaker should trip in approximately 10 to 45 seconds  
depending on the time band (see current-time curve,  
Figures 7D, 7E)  
Reduce or shut off current.  
Repeat as desired  
Set instantaneous (or transfer) knob at 5X  
Close Breaker  
Quickly increase current to 2.5 Amps  
Breaker should trip instantly at 2.5 Amps or a little less  
Reduce or shut off current  
Repeat as desired  
Restore original settings and tighten shaft locks

This function test will show that the time delay circuit and the short time circuit are functioning. Repeatability should be good, but the specific value of time delay should not be judged except in the broad sense.

Obviously, other parameters can be used for this test - those described will give a reasonably fast test with minimum test power. Higher currents at the "A" setting will give faster trip times. Settings other than "A" require more current to get the desired multiples of pick-up (e.g. 3 Amps at "E" setting is required for 3X pick-up).

The function test may be repeated using terminals 2-4 and 3-4 (Model A1 and D); or terminal 3-2 (Model AG and DG). It is not recommended to test terminals 4-2 on the Models AG, DG since the ground detection transformer circuit has a very much higher impedance and is beyond the capabilities of the usual low power test facilities.

If the breaker fails to trip or trips instantly at 1.5 amperes, it is suggested that the factory be contacted. Only personnel who are thoroughly familiar with circuits of this type should attempt to locate and correct troubles.

The above test is believed to be adequate for the majority of applications of low voltage circuit breakers. However, those who require close coordination with other devices and wish to check calibration periodically, may do so in the field with a reasonable degree of accuracy by using somewhat more elaborate equipment and test procedures.

Further test information is available in static trip overcurrent trip device Instruction Book BWX-6678-1.

[www.ElectricalPartManuals.com](http://www.ElectricalPartManuals.com)

### 3. RELEASE MAGNET

The release magnet is illustrated in Figure 8. During normal operation, trip rod (801) which is attached to a spring loaded armature inside the magnetic release latch cylinder cannot move due to a magnetic field set up by permanent magnet (802) which holds the internal armature against plate (803) on the bottom of the magnetic release latch.

When an overload or fault condition exists, coil (804) which is inside on the bottom of the magnetic release latch is energized by the static trip device creating a flux which decreases the magnetic hold force on the spring loaded internal armature allowing the armature to be forced upward due to the spring load, thereby allowing trip rod (801) to move up against trip arm (805), in turn, tripping the circuit breaker. As the breaker opens, coil (804) becomes de-energized due to de-energization of the static trip device, cam (806) rotates arm (807) forcing spring loaded armature against plate (803) allowing trip rod (801) to be reset to the non-trip position.

If the spring loaded armature does not reset during trip operation as explained above, spacers (808) may be added to obtain positive reset of the armature.

If adding spacers does not allow armature to be reset, the magnetic release latch should be replaced. (If breaker mechanism is not at fault).

Do not attempt to disassemble the magnetic release latch as this will destroy the magnetic field set up by the permanent magnet and will render the release latch inoperative permanently.

When replacing a magnetic release latch, the coil (804) leads must be connected to the terminal block of the static trip in the correct polarity relationship.

The black lead of coil (804) must be connected to terminal 7 (negative) and the red lead of coil (804) connected to terminal 8 (positive) of the static trip device.

A clearance of .06 should be maintained between the trip arm (805) and nut (809) with the circuit breaker open, springs charged and trip arm (805) reset by the trip shaft. Adjustment is made by positioning nut (809) while holding trip rod (801).

When the magnetic release latch has been replaced the circuit breaker should be given a FUNCTION TEST as explained previously to ensure proper operation of all components.

[www.ElectricalPartManuals.com](http://www.ElectricalPartManuals.com)

## SECTION V, FUSE FUNCTIONS

### A. CURRENT LIMITING FUSE (Fig. 16)

The C. L. Fuse (1601) NEMA Class "J" and Class "L" have an interrupting rating of 200,000 Amps RMS symmetrical.

When replacement is required due to the C.L. fuse interrupting, replace only with the same fuse rating that was supplied with the circuit breaker.

To remove the C.L. fuse (1601), remove bolts (1602) and associated hardware. Remove fuse. To replace the C.L. fuse, reverse the above procedure.

### B. TRIGGER FUSE (Fig. 16)

The trigger fuse (1603) and associated trip mechanism has a dual function. The first function is to trip the circuit breaker mechanically when the C.L. Fuse (1601) has interrupted.

The second function is to indicate which phase C.L. fuse (1601) has interrupted.

The plunger (1604) on top of the trigger fuse (1603) indicates visually which phase C.L. fuse (1601) has interrupted.

The trigger fuses (1603) are wired in parallel with the C.L. fuse (1601). When the C.L. fuse (1601) interrupts, its associated trigger fuse (1603) also opens and releases a plunger (1604) which is operated by a precompressed spring contained in the trigger fuse (1603) housing.

The plunger (1604) operates arm (1605) which allows spring loaded lever (1606) to engage circuit breaker trip arm (1607) which trips the circuit breaker and holds the circuit breaker in the mechanical trip free position.

The circuit breaker will remain trip free (cannot be closed) until the trigger fuse has been replaced and the associated trip mechanism reset lever (1608) has been manually reset (pushed in).

To remove the trigger fuse (1603) remove strap (1609), remove plastic cover (1610), then the trigger fuse.

To insert the trigger fuse (1603), reverse the above procedure.

**CAUTION:** The trigger fuse (1603) must be inserted with the plunger (1604) facing arm (1605). The .125 +0 - .032 dimension must be maintained.

[www.ElectricalPartManuals.com](http://www.ElectricalPartManuals.com)

# ALLIS-CHALMERS

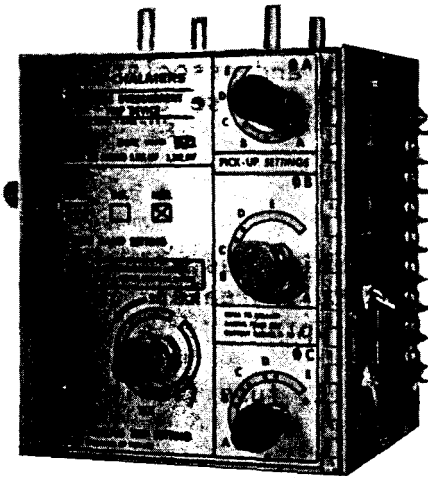

205422 MODEL A-1, A-2  
DUAL STATIC  
TRIP DEVICE

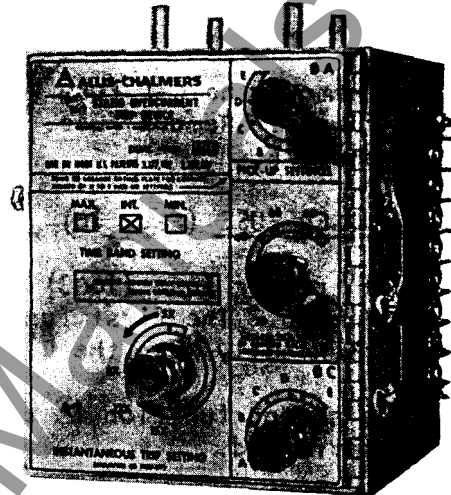

205421 MODEL AG, AG-1  
DUAL STATIC  
TRIP DEVICE

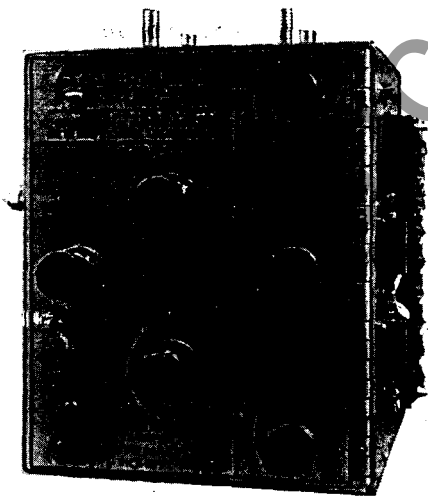

205420 MODEL D, D-1  
SELECTIVE STATIC  
TRIP DEVICE

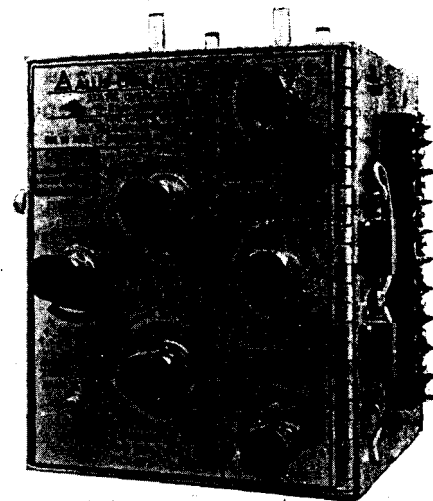

205419 MODEL DG  
SELECTIVE STATIC  
TRIP DEVICE

FIG. 7

TYPICAL STATIC OVERCURRENT TRIP DEVICES

[www.ElectricalPartManuals.com](http://www.ElectricalPartManuals.com)

# ALLIS-CHALMERS

<b>ALLIS-CHALMERS</b>	
<small>BOSTON, MASS • MADE IN U.S.A.</small>	
SERIAL NUMBER	
[ ]	
MAX. RATED AMPS	<b>1000</b>
PICK-UP SETTINGS (AMPS)	A <b>500</b>
	B <b>625</b>
	C <b>750</b>
	D <b>875</b>
	E <b>1000</b>
<small>ONE OR MORE U.S. PATENTS 3,177,407</small>	

## TYPICAL BREAKER RATING PLATE

The current transformers each have five continuous current ratings. For the LA-1600 circuit breaker there are five groups of transformers as shown in Table 4.

The current transformers on the upper connectors for the LA-1600 circuit breaker are mounted with the polarity marks facing breaker panel.

The current transformer on the lower connector is mounted with the polarity mark facing away from the breaker panel.

TABLE 4		CURRENT TRANSFORMERS				
TRANSFORMER GROUP NO.	AVAILABLE CONTINUOUS CURRENT RATINGS AND KNOB POSITIONS					
	<u>A</u>	<u>B</u>	<u>C</u>	<u>D</u>	<u>E</u>	
III	125	155	175	220	250	
IV	200	250	300	350	400	
V	300	375	450	525	600	
VI	500	625	750	875	1000	
VII	800	1000	1200	1400	1600	

The LA-600 and other "LA" breakers have similar groups of current transformers available with appropriate current ratings.

FIG. 7A

[www.ElectricalPartManuals.com](http://www.ElectricalPartManuals.com)

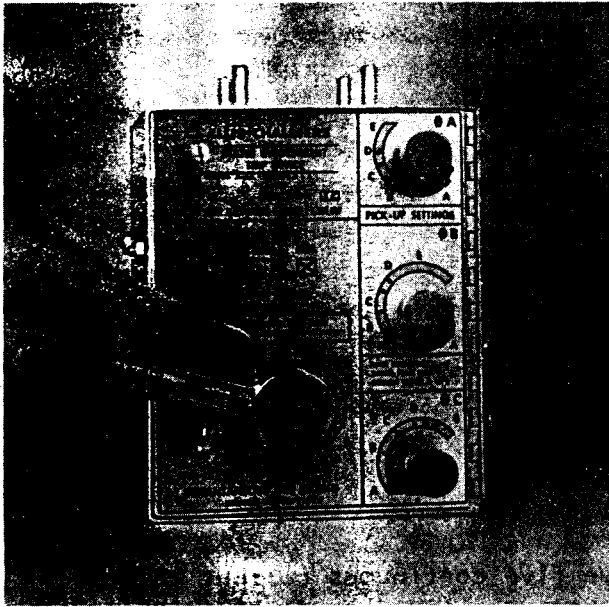

205424

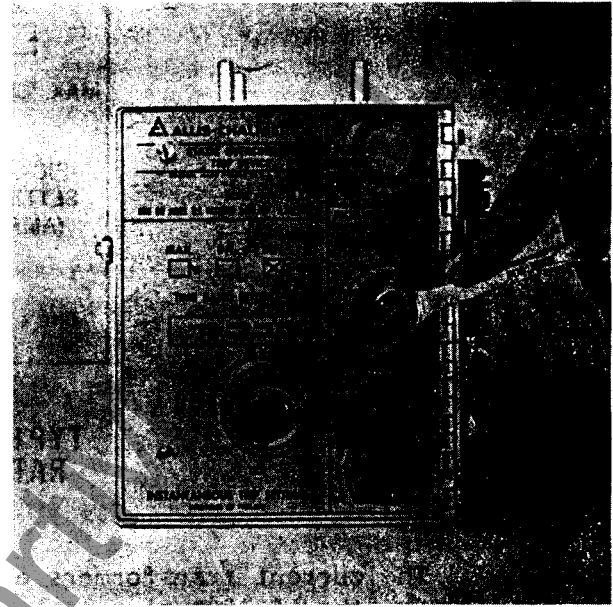

205423

SHAFT LOCKS

**CAUTION:** LOOSEN SHAFT LOCKS  
BEFORE ROTATING KNOBS



CALIBRATION  
REFERENCE  
POINTS

205422

FIG. 7B

SHAFT LOCKS AND CALIBRATION MARKS FOR  
STATIC OVERCURRENT TRIP DEVICES

[www.ElectricalPartManuals.com](http://www.ElectricalPartManuals.com)

# ALLIS-CHALMERS

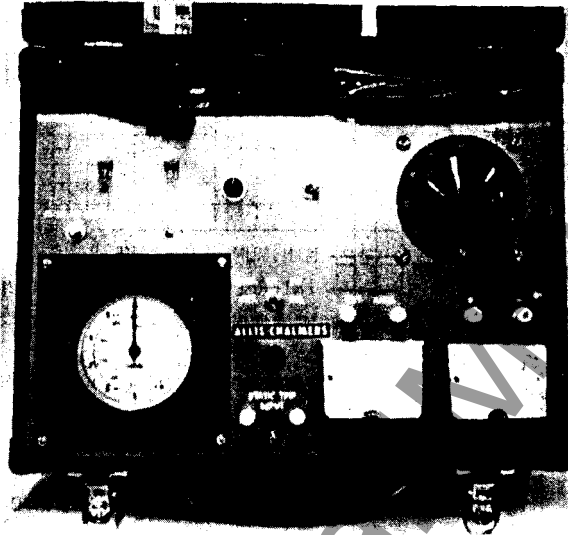

205251

PORTABLE TEST SET FOR STATIC  
OVERCURRENT TRIP DEVICES

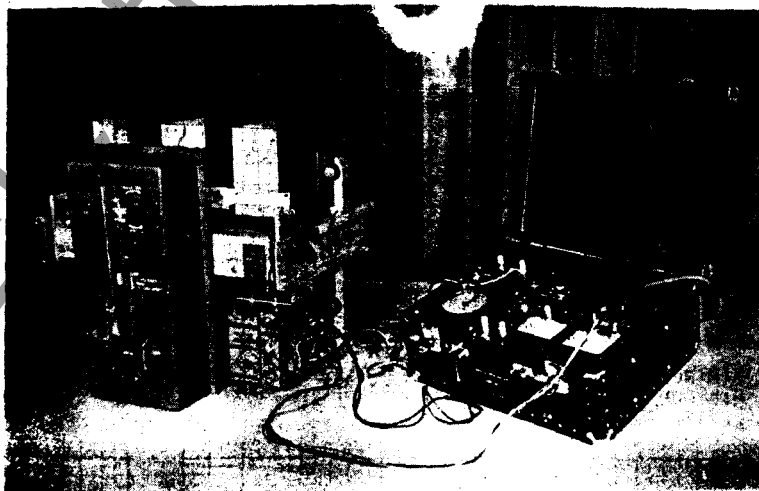

205243

TYPICAL TEST ARRANGEMENT

[www.ElectricalPartManuals.com](http://www.ElectricalPartManuals.com)

# ALLIS-CHALMERS

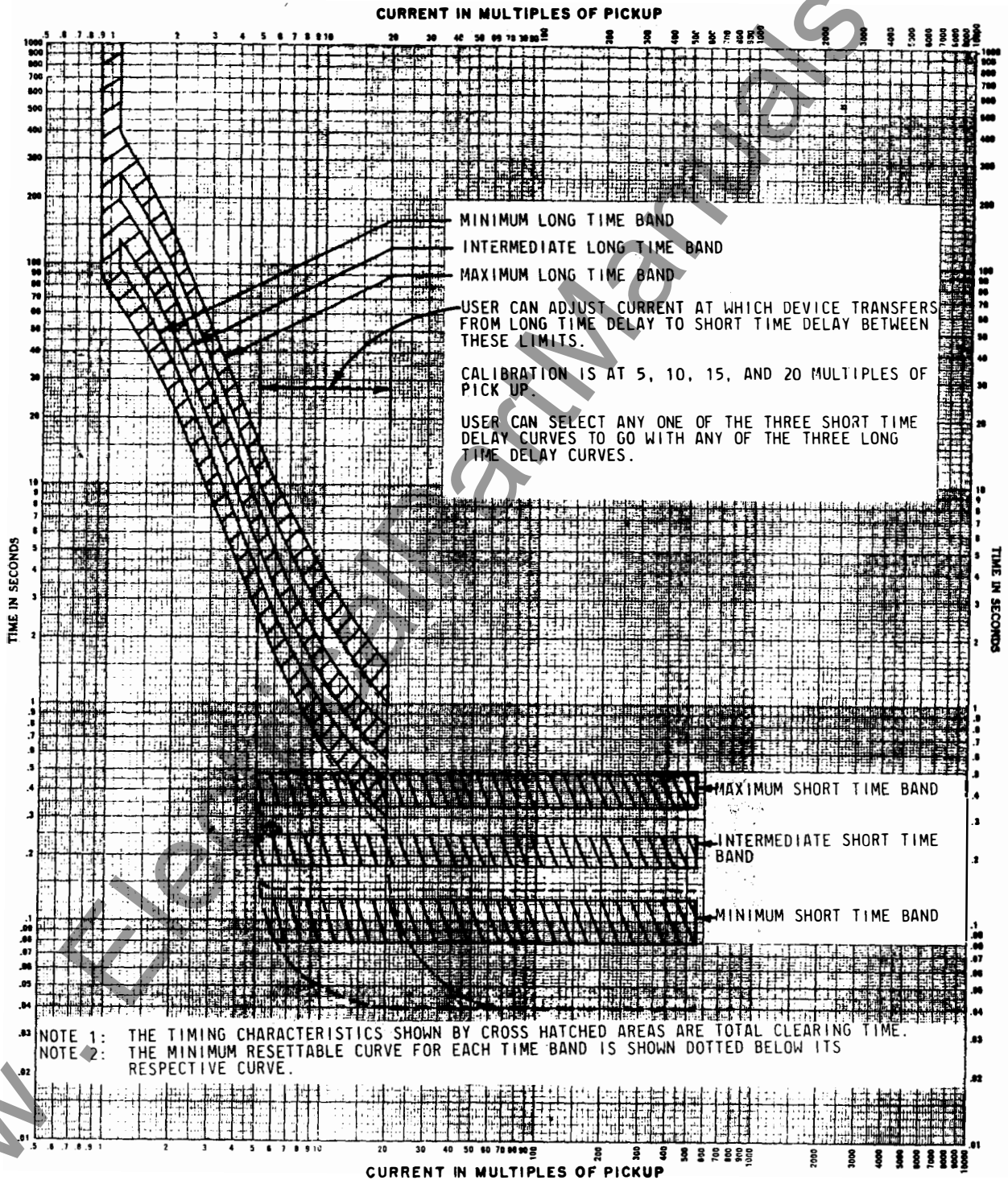

**SELECTIVE STATIC OVERCURRENT TRIP DEVICE — MODEL "D", "D-I", "DG"**  
 JUNE 15, 1964                      TYPICAL CURVE                      71-240-558-405

**FIG. 7D**

[www.ElectricalPartManuals.com](http://www.ElectricalPartManuals.com)

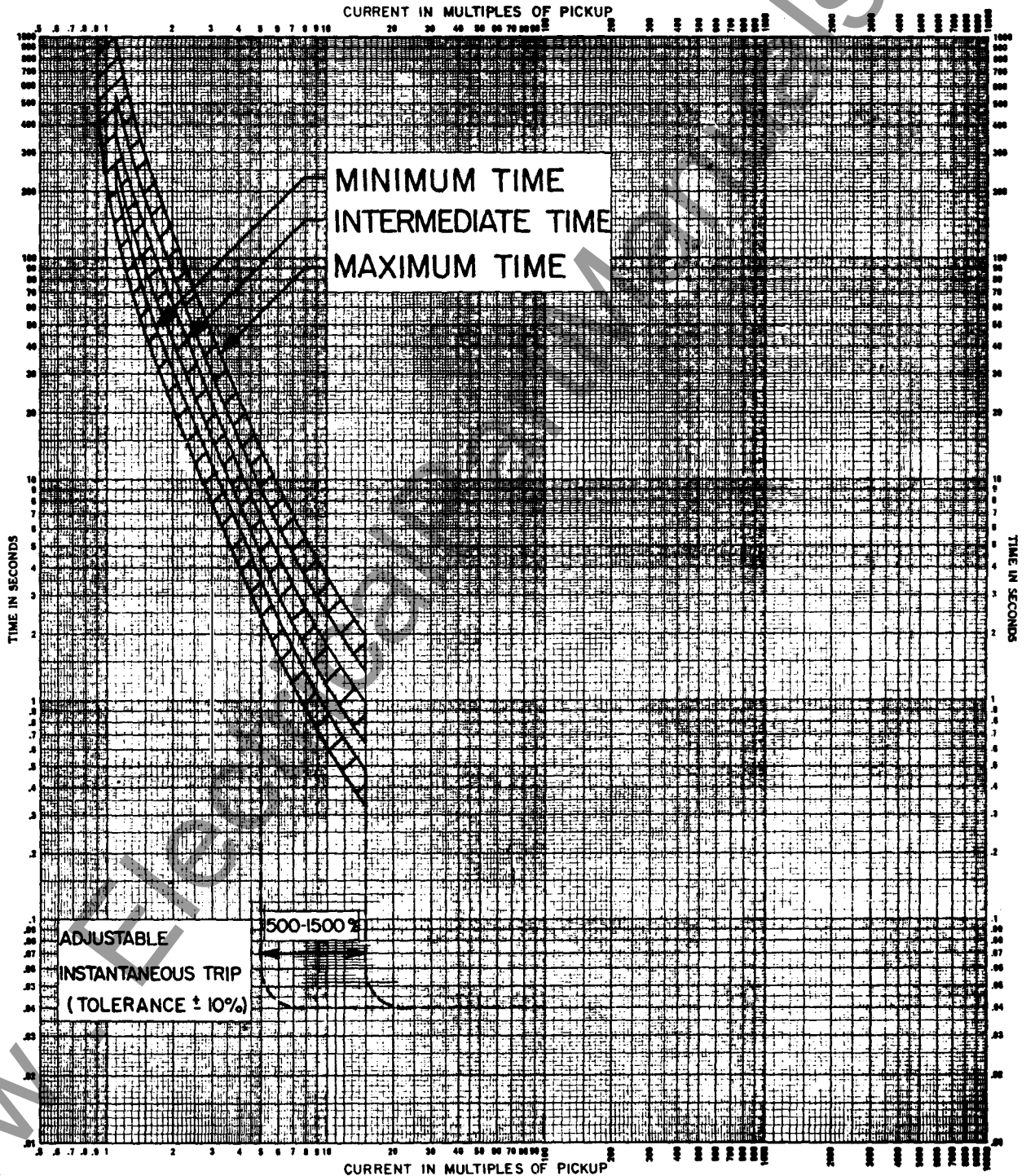

DUAL STATIC OVERCURRENT TRIP DEVICE - MODEL "A", "A-1", "A-G", "A-2", "AG-1"  
 JANUARY 13, 1964 TYPICAL CURVE 71-240-558-404

FIG. 7E

[www.ElectricalPartManuals.com](http://www.ElectricalPartManuals.com)

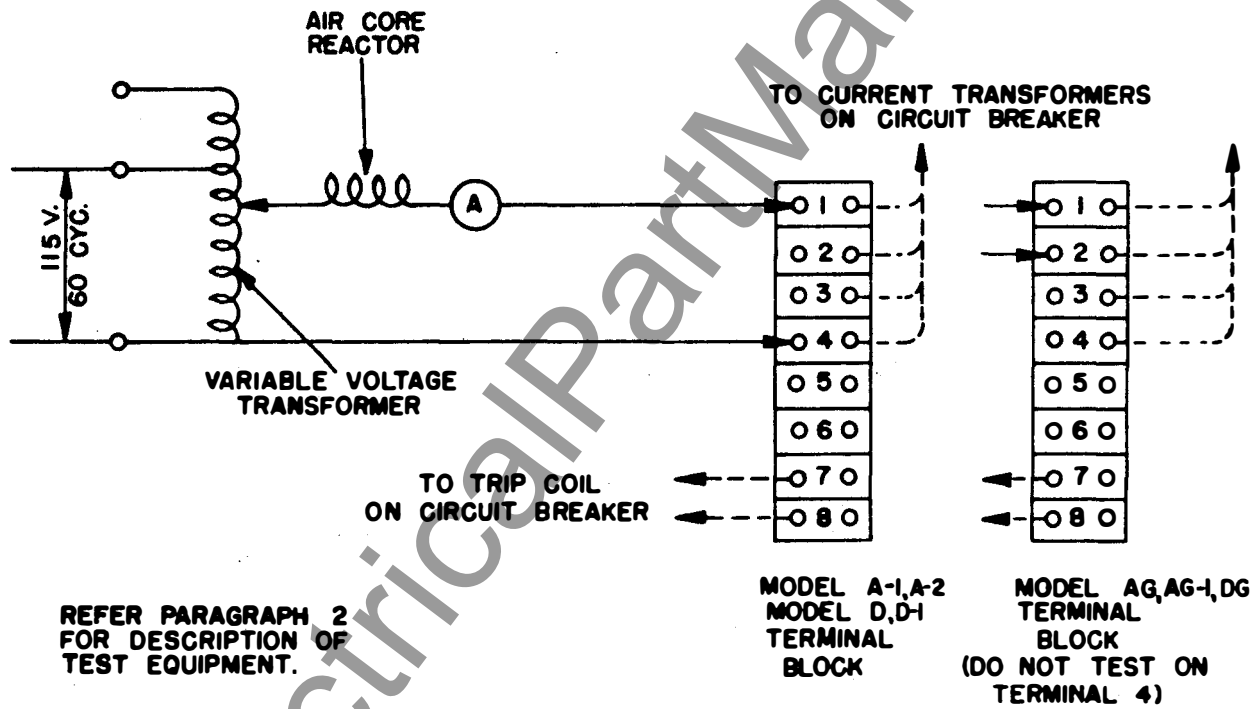

**FIG. 7F**

**CONNECTIONS FOR FUNCTION TESTS**  
 MARCH 7, 1967 71-118-555-402

[www.ElectricalPartManuals.com](http://www.ElectricalPartManuals.com)

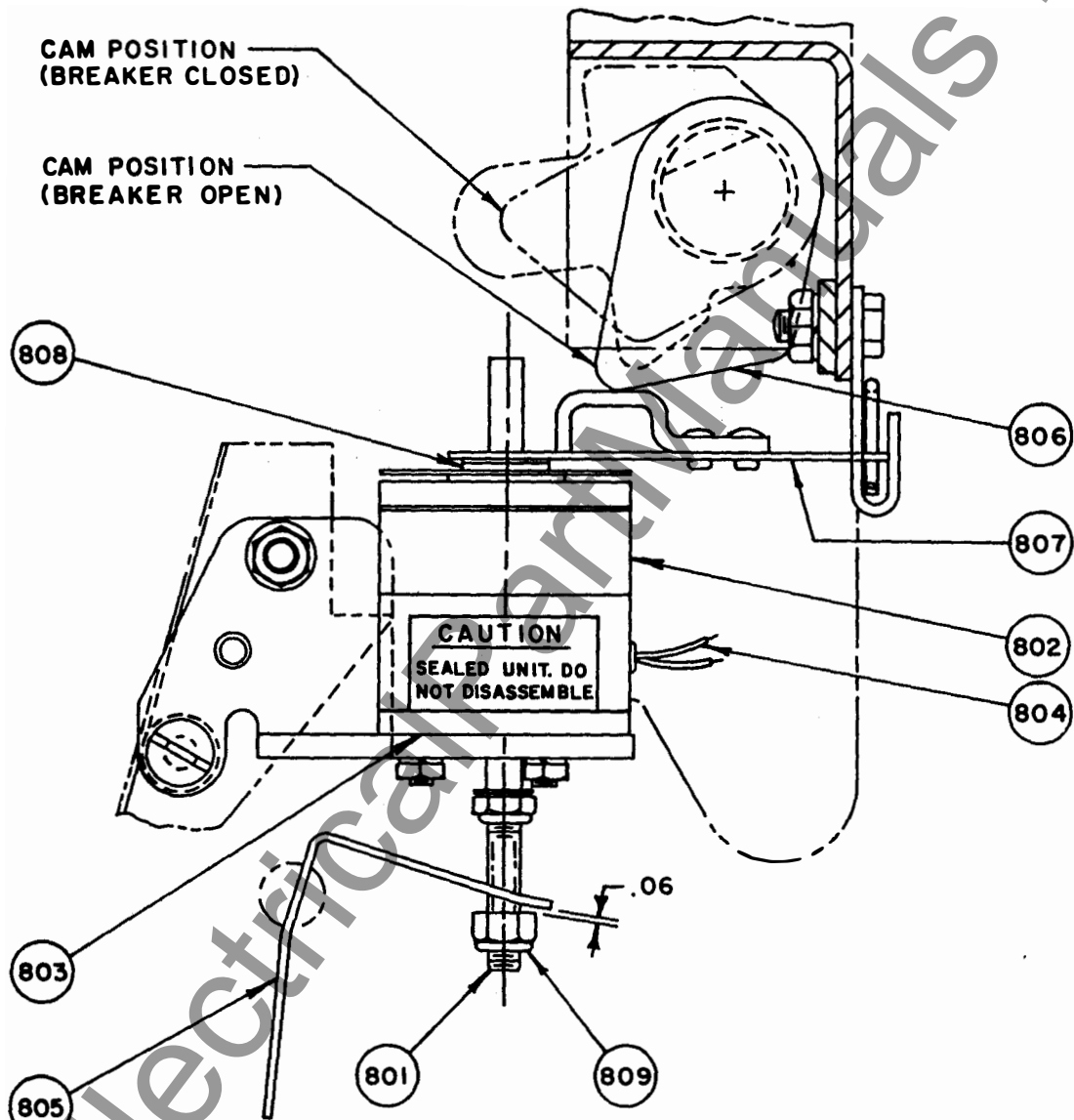

- |               |                       |
|---------------|-----------------------|
| 801. TRIP ROD | 805. BREAKER TRIP ARM |
| 802. MAGNET   | 806. RESET CAM        |
| 803. PLATE    | 807. RESET ARM        |
| 804. COIL     | 808. SPACER           |
|               | 809. NUT              |

**FIG. 8**

TYPICAL RELEASE MAGNET

MAR.2,1967

72-240-068-401

[www.ElectricalPartManuals.com](http://www.ElectricalPartManuals.com)

# ALLIS-CHALMERS

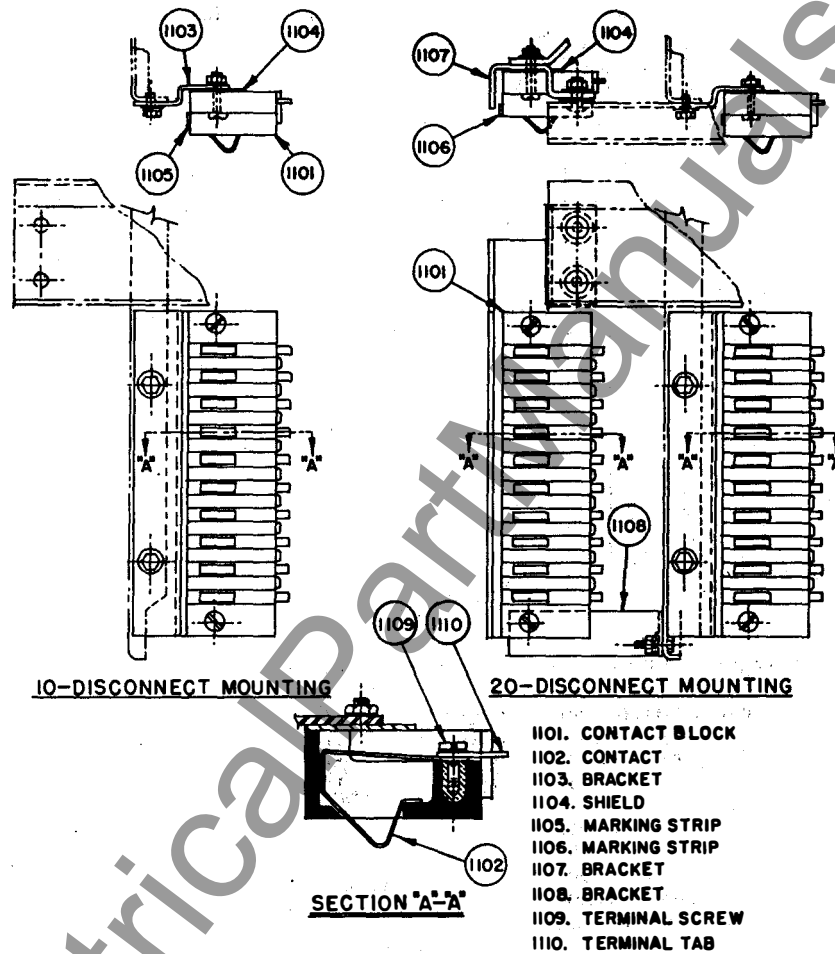

**FIG. II**

TYPICAL SECONDARY DISCONNECTS

DEC. 12, 1966

71-240-584-401

The electrical attachments are wired to the terminals of a secondary disconnect assembly which is mounted on the left side of the breaker. Two blocks of ten terminals each can be mounted on the breaker. The secondary disconnect assembly is accessible from the front of the breaker and aligns with a stationary unit in the cubicle. The stationary contact strips should be lubricated with a light film of "AERO LUBRIPLATE" which is furnished with the switchgear.

[www.ElectricalPartManuals.com](http://www.ElectricalPartManuals.com)

# ALLIS-CHALMERS

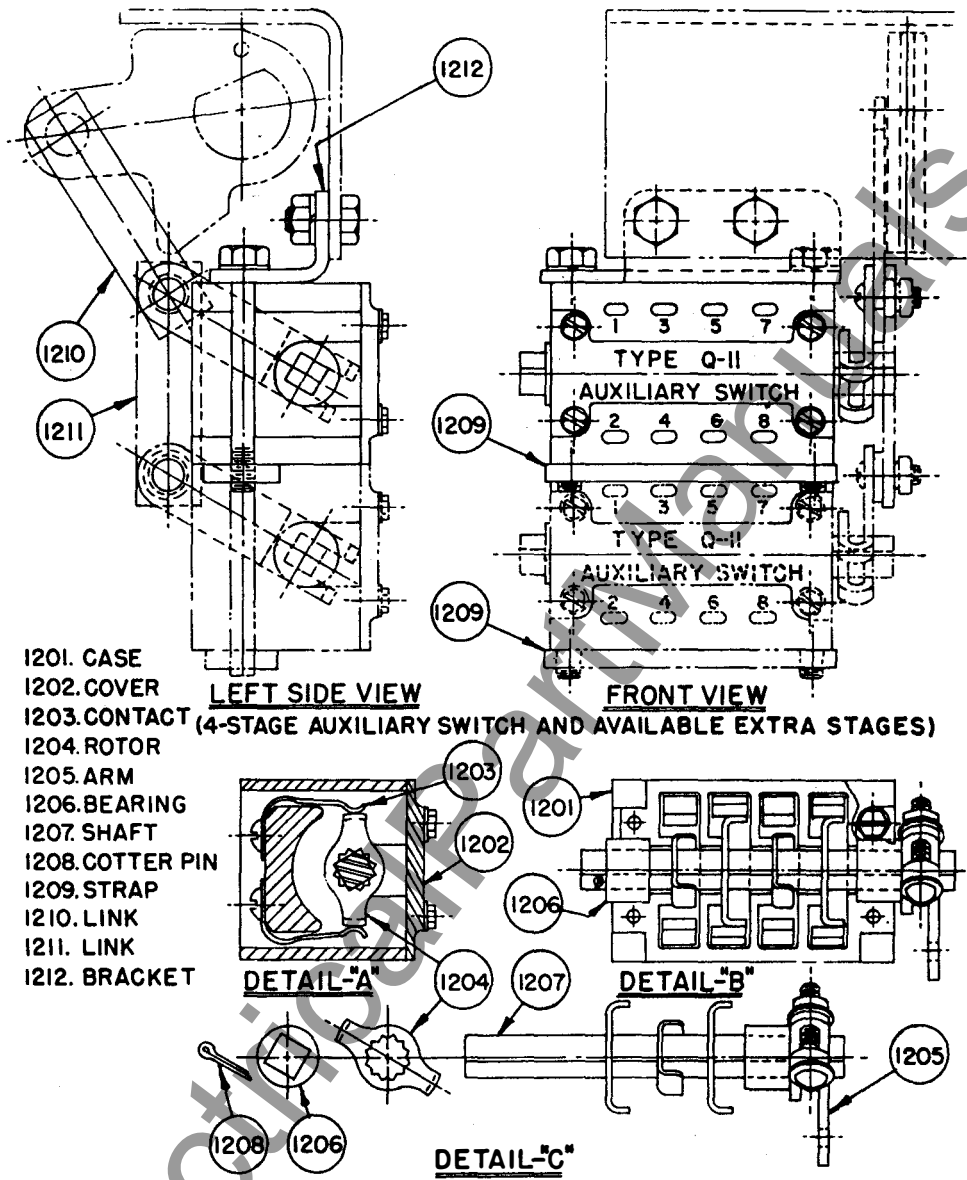

- 1201. CASE
- 1202. COVER
- 1203. CONTACT (4-STAGE AUXILIARY SWITCH AND AVAILABLE EXTRA STAGES)
- 1204. ROTOR
- 1205. ARM
- 1206. BEARING
- 1207. SHAFT
- 1208. COTTER PIN
- 1209. STRAP
- 1210. LINK
- 1211. LINK
- 1212. BRACKET

**FIG.12**

**TYPICAL AUXILIARY SWITCH**  
 MAR. 3, 1967 71-240-587-401

The auxiliary switch is of the rotary type and functions by direct connection to the breaker mechanism. The contacts are factory set for "a" (open when breaker is open) and "b" (closed when breaker is open) position, but each rotor (1204) may be adjusted individually in steps of 30 degrees. This adjustment is made by removing cover (1202) and lifting the entire rotor assembly out of case (1201) after disconnecting arm (1205) from the linkage. Refer to Detail "C". Cotter pin (1208) and bearing (1206) are removed to permit removal of rotors (1204) from shaft (1207). To change rotors (1204) from "a" to "b" position, the rotor should be rotated 60° in the clockwise direction after removal and replaced on the shaft in this new position.

[www.ElectricalPartManuals.com](http://www.ElectricalPartManuals.com)

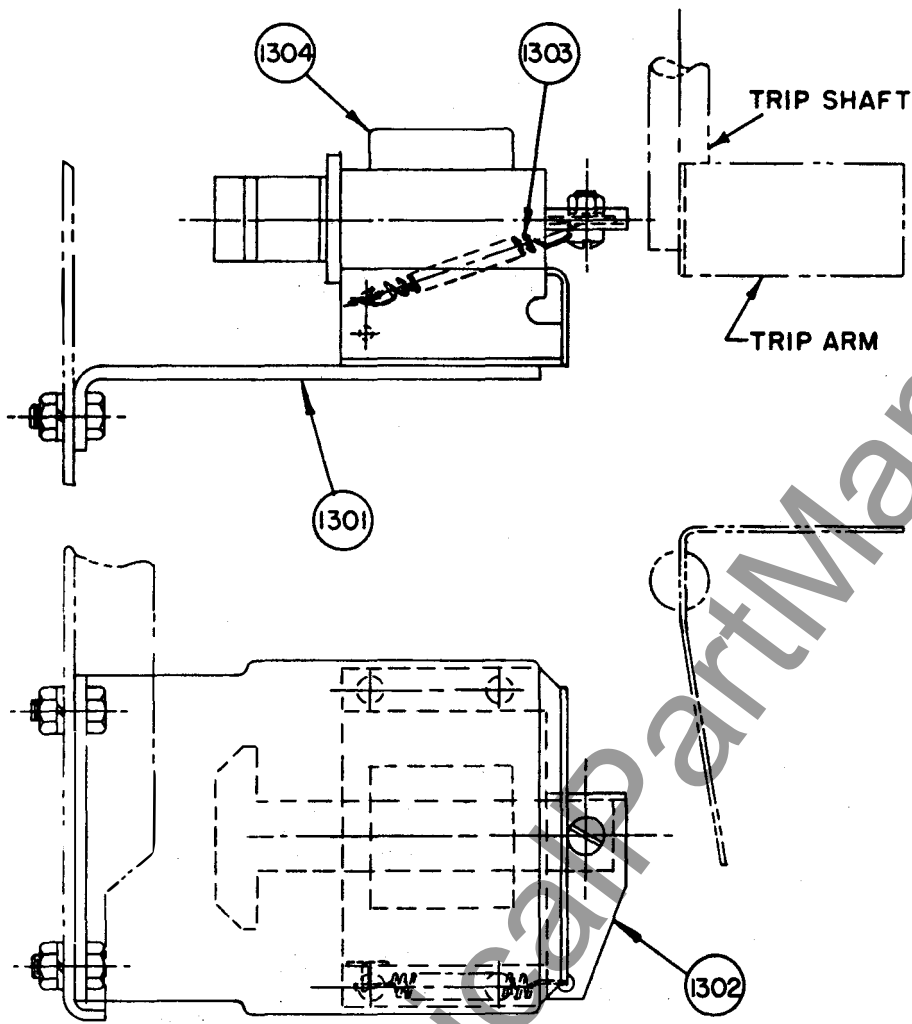

LEFT SIDE VIEW

- 1301. BRACKET
- 1302. STOP
- 1303. SPRING
- 1304. SOLENOID

## FIG.13

### TYPICAL SHUNT TRIP

DEC.12,1966

71-240-586-401

Each electrically-operated breaker is equipped with a shunt trip attachment for tripping from a remote location. Since the shunt trip coil is designed for a momentary duty cycle, an "a" auxiliary contact switch is used to interrupt its circuit immediately after the breaker is tripped. Energization of the coil causes the armature to pick up and rotate the trip arm counter-clockwise to trip the breaker. Extension spring (1303) returns the armature to its normal position.

[www.ElectricalPartManuals.com](http://www.ElectricalPartManuals.com)

# ALLIS-CHALMERS

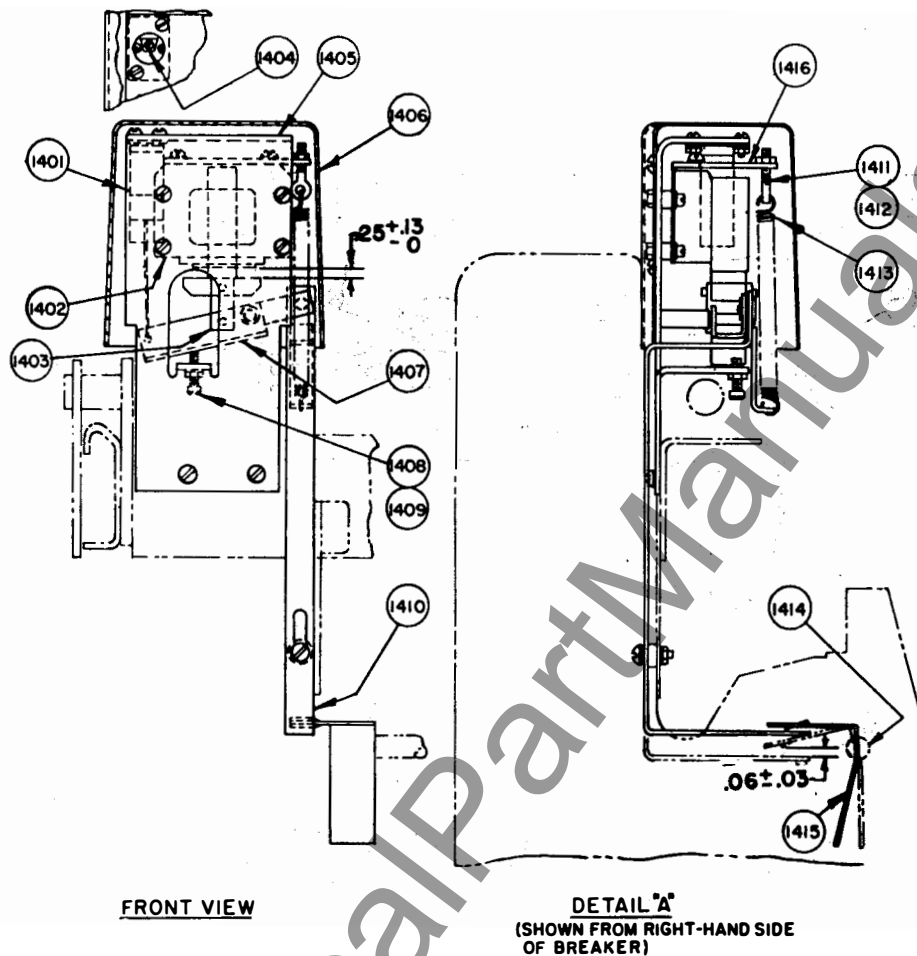

- |                                  |  |
|----------------------------------|--|
| 1401. AIRPOT                     | 1409. LOCKNUT                            |
| 1402. SOLENOID                   | 1410. TRIP BAR                           |
| 1403. LINK                       | 1411. PICK-UP & DROP OUT ADJUSTING SCREW |
| 1404. TIME DELAY ADJUSTING SCREW | 1412. LOCKNUT                            |
| 1405. BRACKET                    | 1413. SPRING                             |
| 1406. COVER                      | 1414. TRIP SHAFT                         |
| 1407. ARM                        | 1415. TRIP ARM                           |
| 1408. ADJUSTING SCREW            | 1416. PLATE                              |

## FIG.14

### TYPICAL UNDERVOLTAGE DEVICE

MARCH 3, 1967

71-240-615-402

The undervoltage trip device automatically trips the breaker when the voltage drops below a predetermined value. Either instantaneous or time-delay operation can be supplied. Adjusting screw (1408) should be set to provide an air gap of .25" between the solenoid pole head and armature with the device de-energized as shown in the front view. A .06" gap should be maintained between trip arm (1415) and trip bar (1410) when the device is energized with the breaker closed as shown in Detail "A". Pick-up and drop-out adjusting screw (1411) should be set so that the device picks up at a voltage of 80% or more of rated value and drops out between 30% and 60% of the rated value. On devices equipped with time delay airpot (1401), adjusting screw (1404) can be set to provide a range of time delay between 0.5 and 4.5 seconds. Tightening the screw increases time delay.

[www.ElectricalPartManuals.com](http://www.ElectricalPartManuals.com)

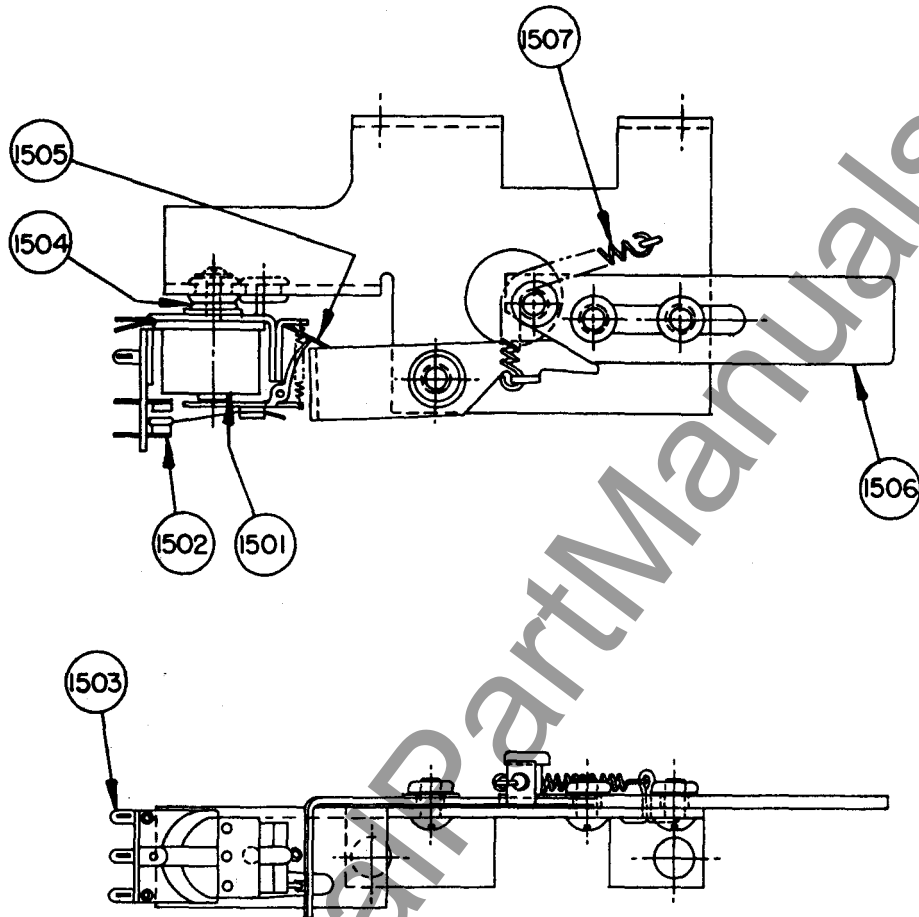

- |                        |                     |
|------------------------|---------------------|
| 1501. BELL ALARM RELAY | 1505. LATCHING ARM  |
| 1502. RELAY CONTACTS   | 1506. RESET PLUNGER |
| 1503. TERMINAL LUGS    | 1507. SPRING        |
| 1504. SPACER WASHERS   |                     |

## FIG.15

### TYPICAL BELL ALARM (MANUAL RESET)

DEC.12,1966

71-240-588-401

The bell alarm attachment functions to close or open an alarm circuit upon automatic overcurrent tripping of the breaker. The relay coil is wired to terminals 7 and 8 of the static trip device. This is a latching-type relay and relay contacts (1502) are reset to the open position shown by actuating reset plunger (1506). Spacer washers (1504) are used to position the relay to ensure correct engagement of latching arm (1505) when resetting the contacts.

[www.ElectricalPartManuals.com](http://www.ElectricalPartManuals.com)

# ALLIS-CHALMERS

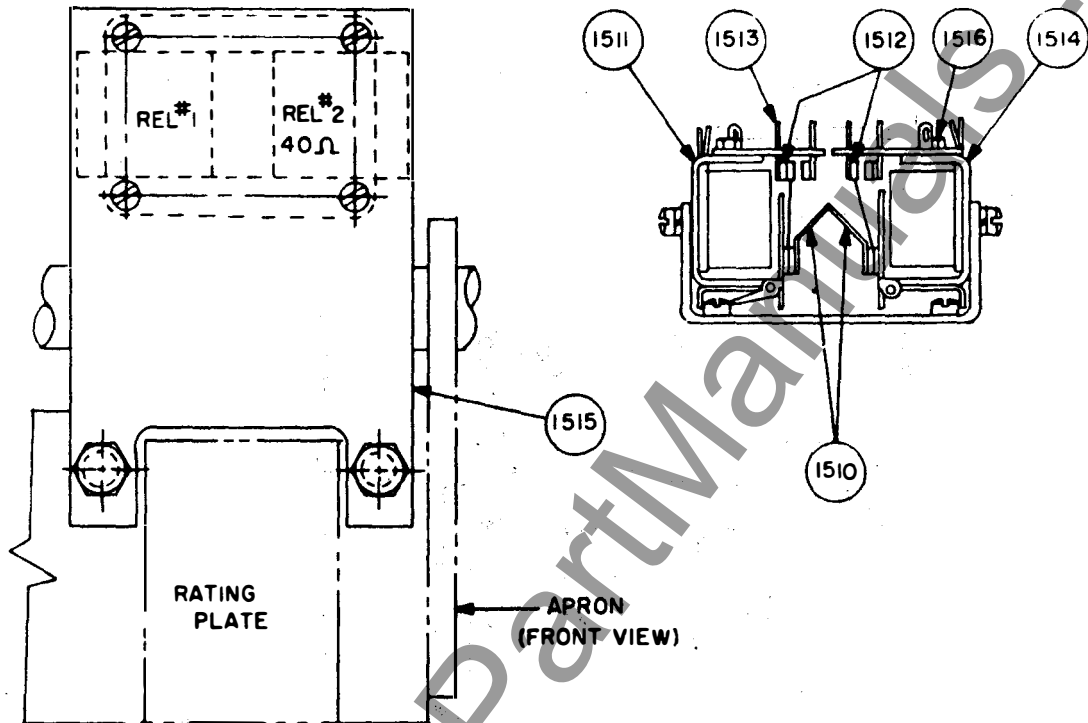

1510. LATCHING ARMS  
 1511. RESET RELAY  
 1512. RELAY CONTACTS  
 1513. TERMINAL LUGS

1514. BELL ALARM RELAY  
 1515. BRACKET  
 1516. HEX. HD. SCREW

**FIG. 15A**

## TYPICAL BELL ALARM (ELECTRICAL RESET)

AUGUST 1968

71-240-620-402

The bell alarm attachment functions to close or open an alarm circuit upon automatic overcurrent tripping of the breaker. It consists of two relays with interlocking armatures. The bell alarm relay (1514) coil is wired to terminals 7 and 8 of the static trip device. As this is a latching type relay, the alarm relay contacts (1512) are reset electrically to the open position shown by actuating reset relay (1511). If the device is not stable during breaker operation or if either armature fails to pick up when actuated, loosen hex head screw (1516) to re-position the terminal board. This changes the engagement between the interlocking latching armatures and the relationship between the stationary and movable contacts.

[www.ElectricalPartManuals.com](http://www.ElectricalPartManuals.com)

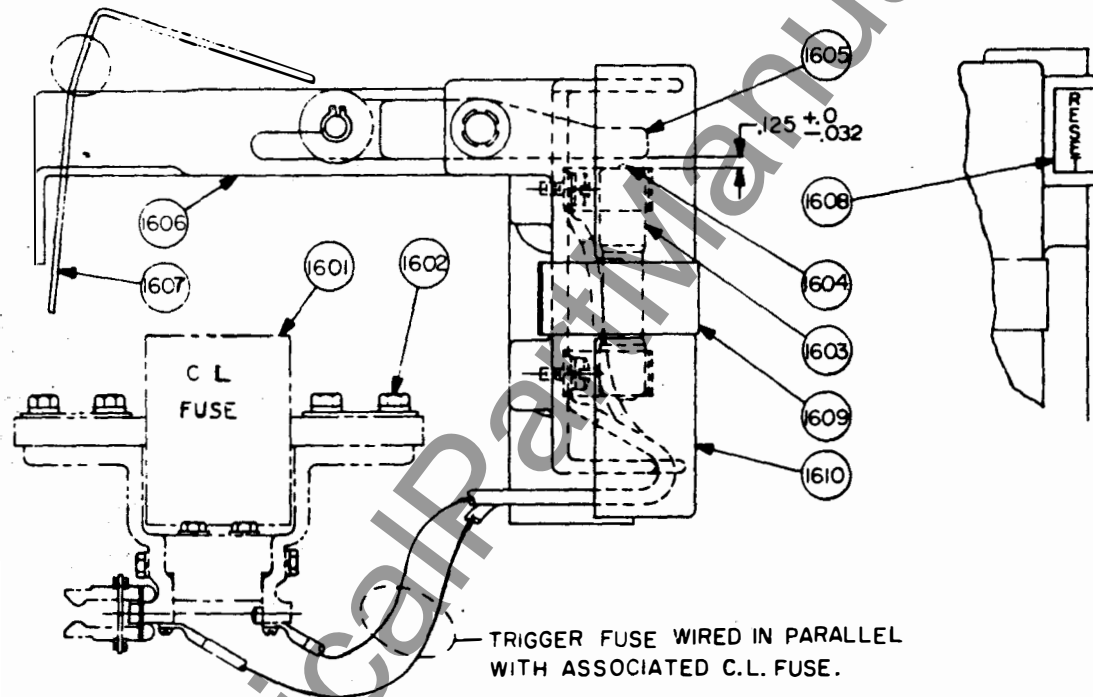

- 1601. C.L. FUSE
- 1602. BOLTS
- 1603. TRIGGER FUSE
- 1604. PLUNGER
- 1605. ARM
- 1606. LEVER
- 1607. TRIP ARM
- 1608. RESET LEVER
- 1609. STRAP
- 1610. COVER

**FIG. 16**  
**CURRENT LIMITING**  
**AND**  
**TRIGGER FUSE**

AUGUST 1968 72-240-102-401

**A ALLIS-CHALMERS**

[www.ElectricalPartManuals.com](http://www.ElectricalPartManuals.com)

# ALLIS-CHALMERS

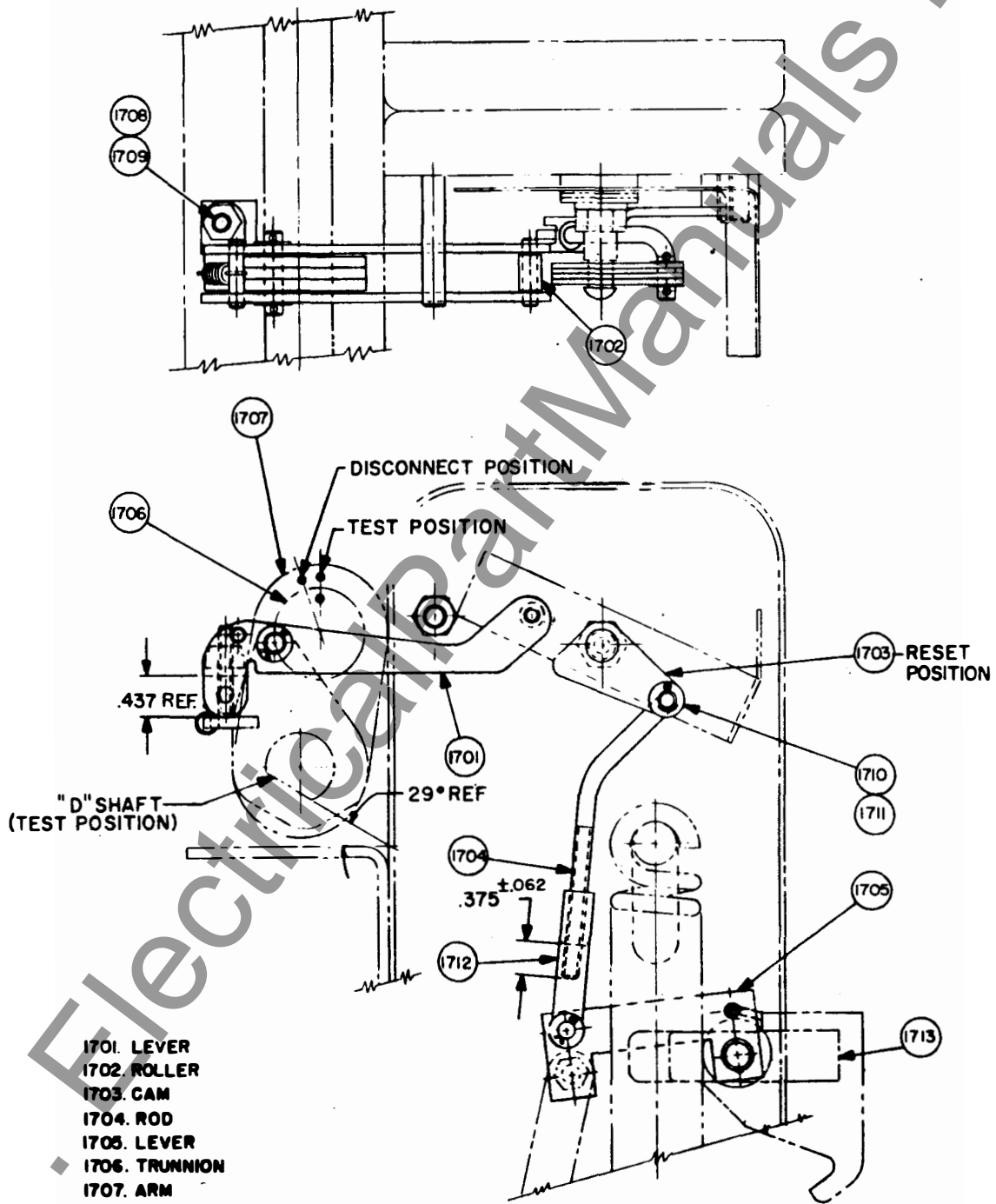

**FIG. 17**

**SPRING DISCHARGE MECHANISM**  
 UGUST 1968 72-240-103-401

- 1701. LEVER
- 1702. ROLLER
- 1703. CAM
- 1704. ROD
- 1705. LEVER
- 1706. TRUNNION
- 1707. ARM
- 1708. SET SCREW
- 1709. NUT
- 1710. COTTER PIN
- 1711. WASHER
- 1712. YOKE
- 1713. LATCH

[www.ElectricalPartManuals.com](http://www.ElectricalPartManuals.com)