

ALLIS-CHALMERS

**INSTRUCTION
BOOK**

**RUPTAIR MAGNETIC POWER
CIRCUIT BREAKER**

Type D Movable Portion

Ma 75-150-250-350 C

DECEMBER 1968

BWX-6731

INDEX

PAGE

1. OUTLINE
2. OUTLINE
3. INTRODUCTION.
4. AUXILIARY CONTROL EQUIPMENT

MA-150/250C
MA-350C

6. ARC CHUTE
8. INSTALLATION
9. STORAGE & PREPARATION
10. SOLENOID OPERATOR
11. THEORY OF OPERATION
13. CONTROL
14. REVERSE "Y"
16. STORED ENERGY OPERATOR
17. THEORY OF OPERATION

20. CONTROL SWITCH
22. LATCH LOCK DEVICE
24. CONTROL

28. SPRING DISCHARGE
29. MAINTENANCE
30. STUD & SUPPORT

ADJUSTMENTS

31. CONTACTS
35. AUXILIARY SWITCH
37. SOLENOID OPERATOR
39. STORED ENERGY OPERATOR
40. SPRING RELEASE LATCH
41. SPRING DISCHARGE
42. "88" SWITCHES

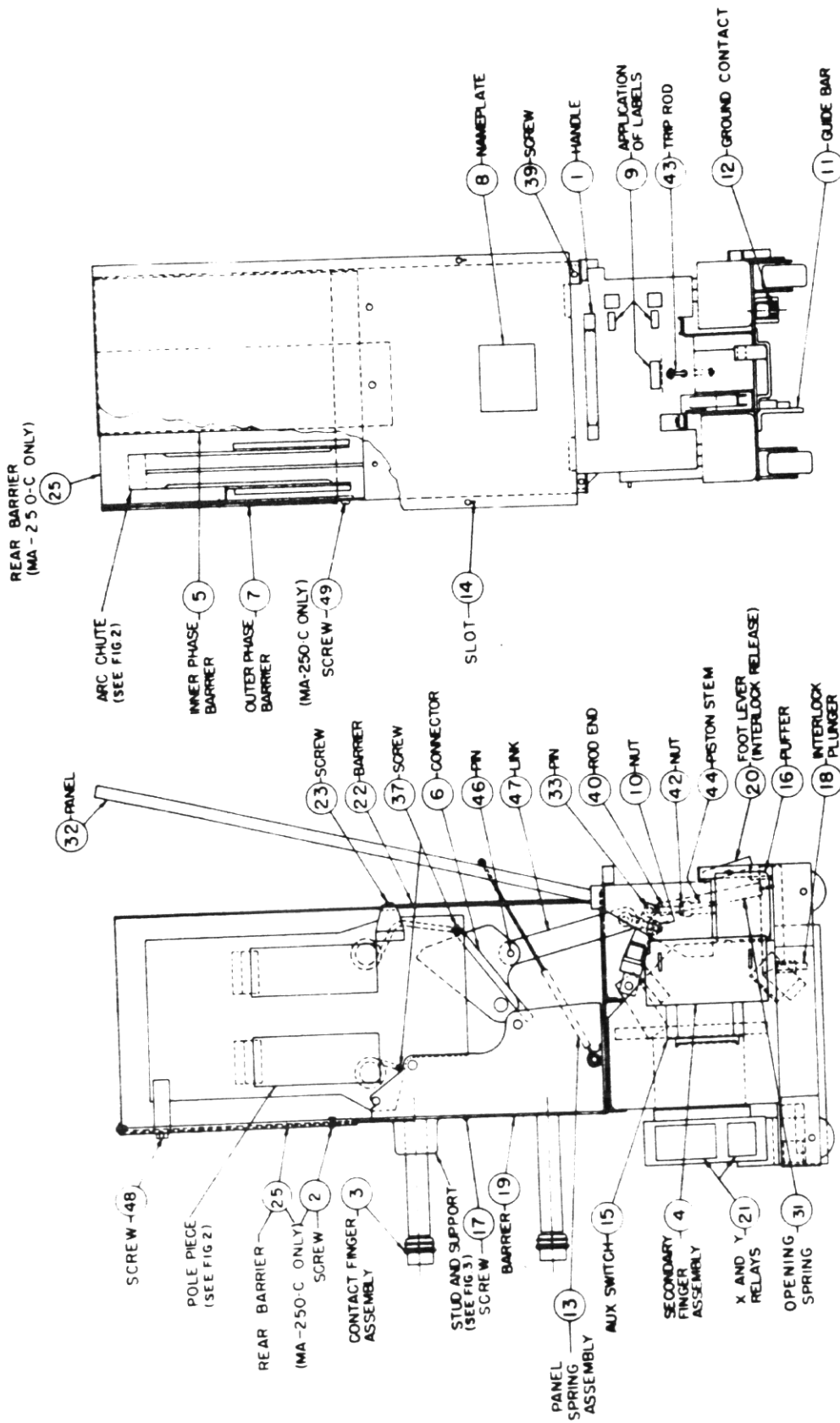

FIG. 1-A
TYPICAL MA-150/250-C BREAKER
WITH SOLENOID OPERATOR
 JAN 10, 1969
 72-420-046-401

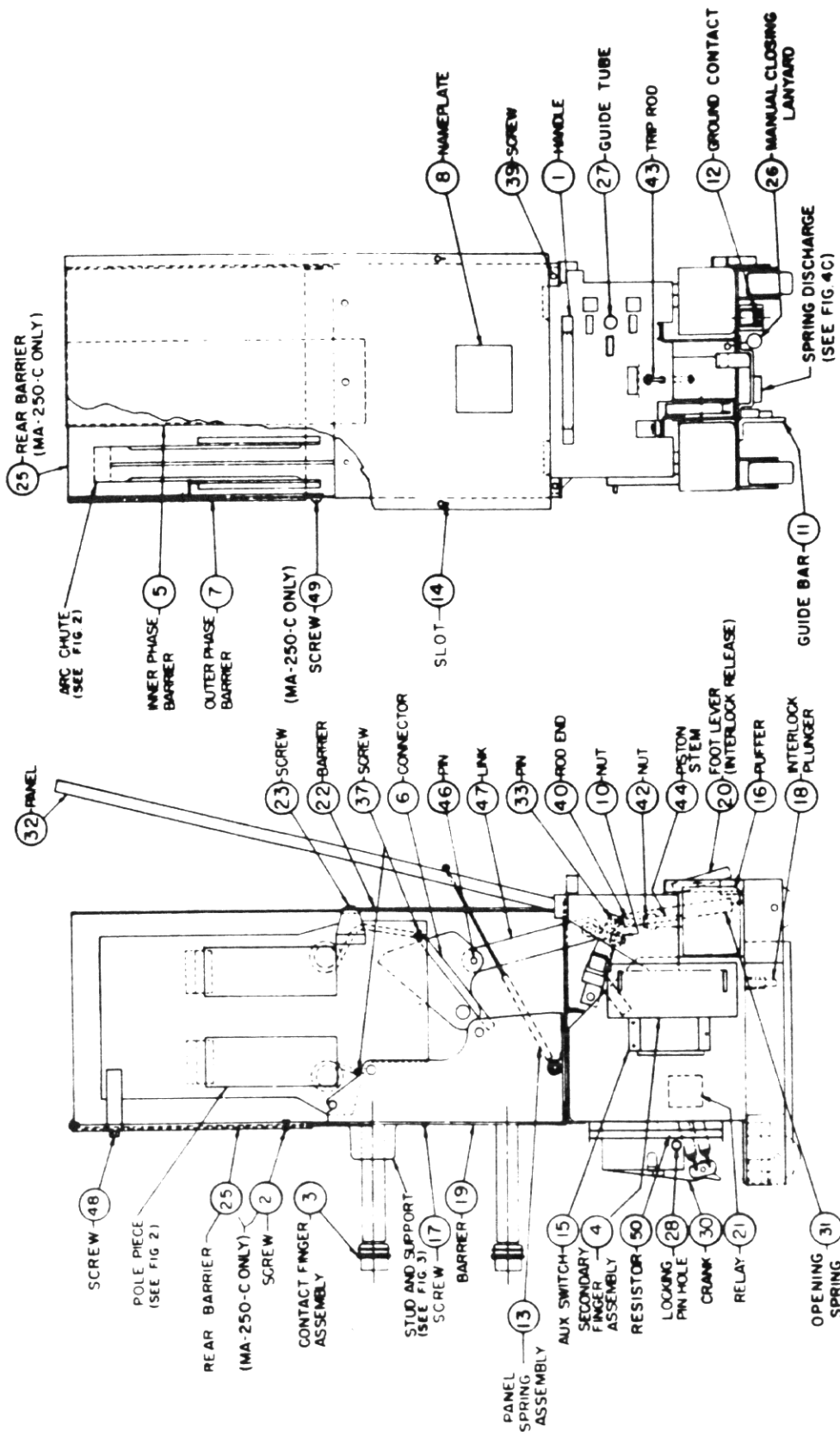

FIG 1-B
TYPICAL MA-150/250-C BREAKER
WITH STORED ENERGY OPERATOR
 JAN 10, 1969
 72-420-037-401

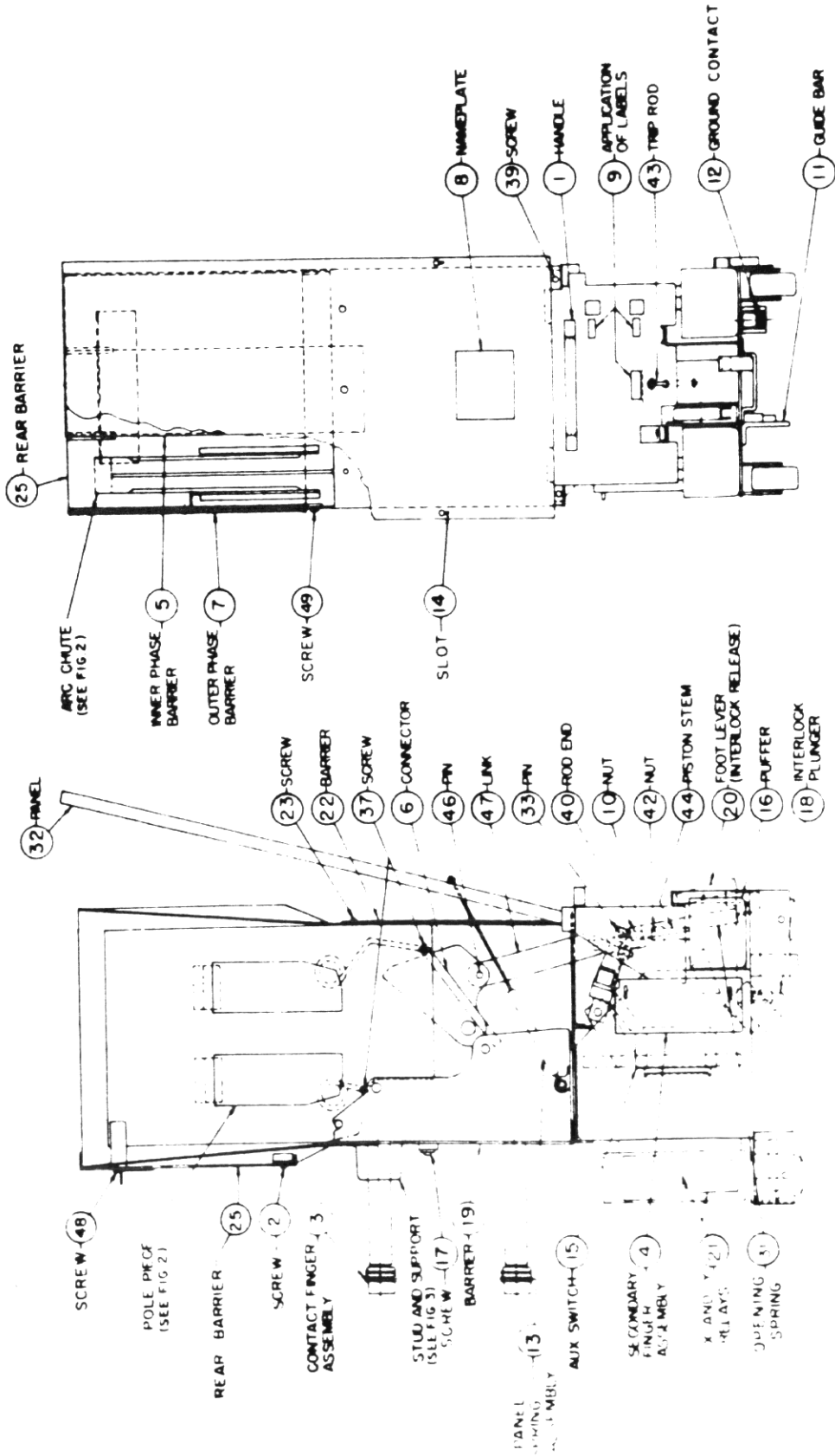

FIG. 1-C
TYPICAL MA-350-C BREAKER
WITH SOLENOID OPERATOR
 JAN 10, 1969 72 4 20 047 401

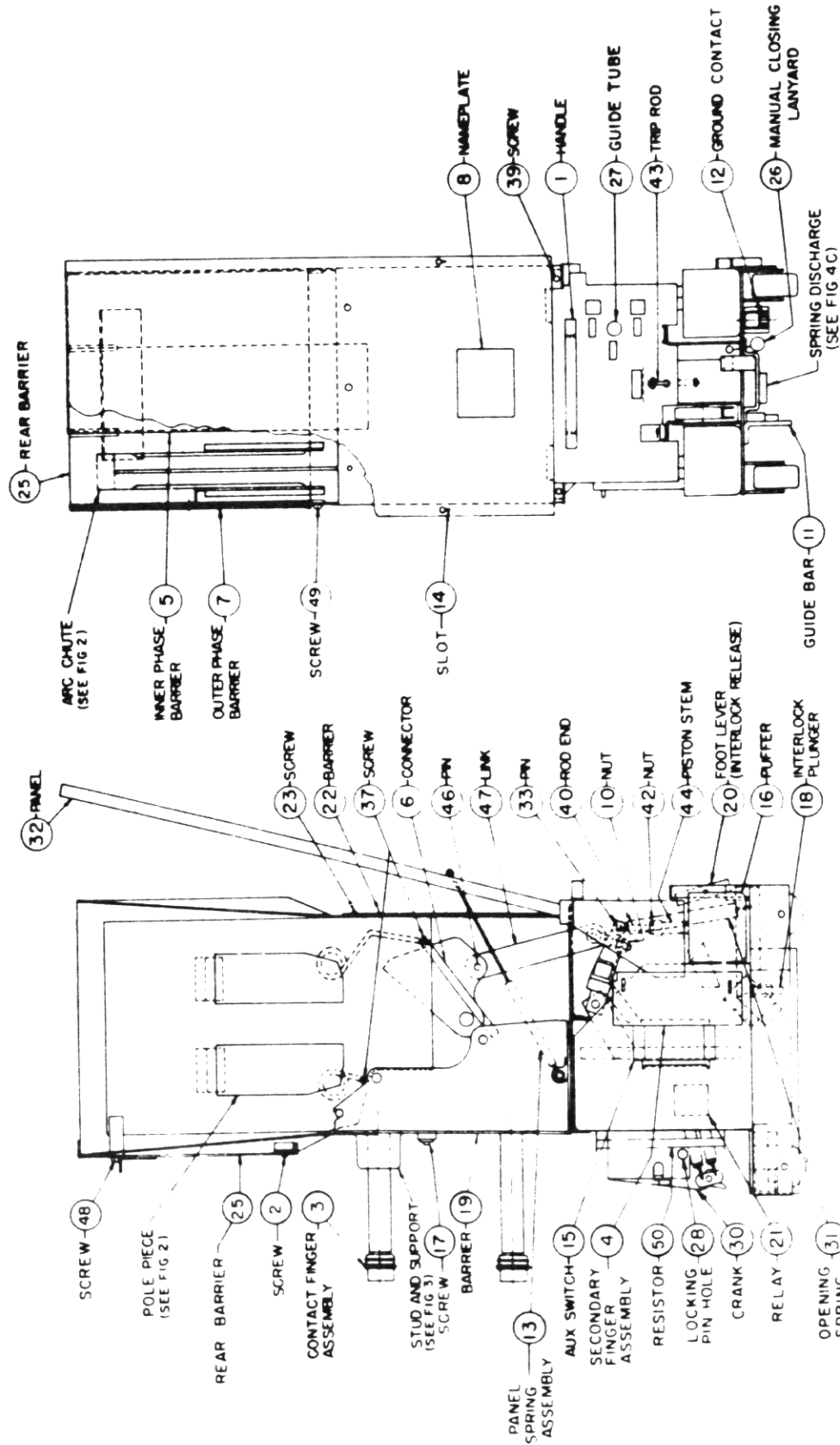

FIG. 1-D

TYPICAL MA-350-C BREAKER
WITH STORED ENERGY OPERATOR
JAN 10, 1969 72-420-044-401

INTRODUCTION

This instruction manual provides installation, operation, and maintenance information for all 5KV, Allis-Chalmers, air magnetic circuit breakers.

WARRANTY

For warranty coverage, see the sales contract.

DESCRIPTION

A typical circuit breaker consists of primary disconnect, arc chute, and operator sections. The primary disconnect section contains the main contacts, which supply power to the load. The arc chute section dissipates the power arc drawn during the opening of the main contacts. The operator section contains the mechanism used to close and open the main contacts. This mechanism consists of either a solenoid or a stored energy operator with its associated control circuitry.

Arc interruption is accomplished in free air at atmospheric pressure with the aid of a self-induced, magnetic blowout field and forced air draft. When the trip solenoid is energized, load current is being carried by the main contacts. As the main movable contact opens, the arc drawn between the main and stationary contacts quickly transfers to the arcing contacts, keeping main contact erosion to a minimum.

The arc between the arcing contacts is transferred to the arc runners as the movable arcing contact passes near the arc runner. The transfer of the arc to the arc runner establishes full current flow through the blowout coils setting up a strong magnetic field which, accompanied by the natural thermal effects of the heated arc, tends to force the arc upward into the barrier stack. The cool surfaces of the barrier stack cool and de-ionize the arc, while the V-shaped slots in the stack reduce its cross section and elongate it, leading to rapid extinction. The arc runners are made of wide, heavy material for maximum heat dissipation and to minimize metal vaporization.

A puffer mechanism provides a forced air draft through the main contact area. This aids the magnetic blowout field and natural thermal effect in forcing the arc into the barrier stack for easy extinction.

The breaker is closed by the operator straightening a toggle in the four bar linkage (See Page 12). The operator may be powered by a solenoid or by precharged springs (stored energy).

A large DC solenoid is used to drive two links of the 4-bar linkage to an in-line position allowing a prop latch to drop behind a toggle roll in the linkage system to hold the breaker closed.

Stored Energy

The stored energy operator uses charged springs to power the closing operation. Opening is spring powered also but not with the same springs used for closing. A stored energy operator consists of three systems: driving, spring linkage and 4-bar toggle linkage. These systems are disengaged from each other except while performing their specific functions. For example: the driving and spring linkage systems are completely free of each other except when the spring linkage is being charged. Similarly, the spring linkage and 4-bar toggle linkage systems are free of each other except during a closing operation.

AUXILIARY CONTROL EQUIPMENT FOR SOLENOID OPERATED UNITS.

DC Control Relay

The solenoid operator in Allis-Chalmers circuit breakers is designed to operate on DC current only. The control relay actually consists of two relays which may be mounted on a common base. Solenoid current is handled by the main control or X relay while the second relay or Y relay provides auxiliary control.

AC Control Relay

The solenoid operator in Allis-Chalmers circuit breakers is designed to operate on direct current only. For alternating current applications, an AC control relay is used to switch the AC input of a silicon rectifier for control of the solenoid. The DC output of the silicon rectifier is connected directly to the solenoid. The control relay actually consists of two relays which may be mounted on a common base. Alternating current to the rectifier is handled by the main or X relay while the second relay or Y relay provides auxiliary control.

Silicon Rectifier

A full wave rectifier is used to convert alternating current to direct current for the DC solenoid in the solenoid operator.

NOTE: These units are designed for intermittent duty and should not be used for any other purpose.

The four rectifiers (diodes) are mounted on heat sinks which are assembled together with a terminal block on a chassis. The diodes are connected to form a full wave, single phase, bridge. Direction of current flow does not affect solenoid operation.

Nominal operating voltage for the rectifier is up to 300V AC.

The junctions of these rectifiers can be damaged by over-voltage or heating due to excessive current flowing through them. Protection against switching transients is provided by a suppressor.

Rectifier junctions will be destroyed if the full E/R closing current flows for more than a second or two as might occur if the breaker fails to close normally due to mechanical difficulty. To protect the rectifier, a fuse is provided in the closing circuit capable of blowing under such conditions. The blown fuse must be replaced only with another of the same type and rating. As a safety measure, the fuse should always be in series with the rectifier during any test operations. Limit such operations to not more than two a minute.

Silicon Rectifier Kit - 71-113-175-805. This kit is available from Allis-Chalmers for converting from copper oxide to silicon for rectifier closing of circuit breakers. The kit consists of a silicon, bridge rectifier assembly with suppressor, a three ohm, tapped resistor, and necessary hardware.

For Stored Energy Operated Units

Stored energy (spring closing) breakers normally require a single commercial relay for control. These are furnished to match the control voltage.

Reset Relay

The reset relay is used for instantaneous reclosure service on stored energy operated breakers in place of a latch check switch. The relay is a solid-state device which operates a small relay. Closing time is not affected by voltage and current variances well beyond the standard circuit breaker control limits. The voltage regulator and timing circuits are mounted on a printed circuit board and encapsulated in a resilient material for shock resistance.

AUXILIARY EQUIPMENT

Auxiliary Switch

The auxiliary switch, mounted on the breaker, is normally used to open the trip circuit when the circuit breaker is closed. As this multi-stage switch operates with the breaker disconnect blades, circuitry dependent on the position of the breaker, as indicator lights, etc., are wired through this switch. The individual stages are easily converted to "a" or "b" without disassembling the switch.

Capacitor Trip Device

A capacitor trip device is commonly used with circuit breakers having an AC control supply which are installed in isolated locations or unattached substations where battery cost and maintenance is undesirable.

In these installations, the capacitor trip device may be charged from the same stepdown transformer that is used to energize the breaker control. Obviously, this stepdown transformer should be connected to the line side of the breaker.

To apply the capacitor trip device to existing breakers originally shipped with DC trip coils, check with the Allis-Chalmers Mfg. Co., Boston Plant, Boston, Massachusetts.

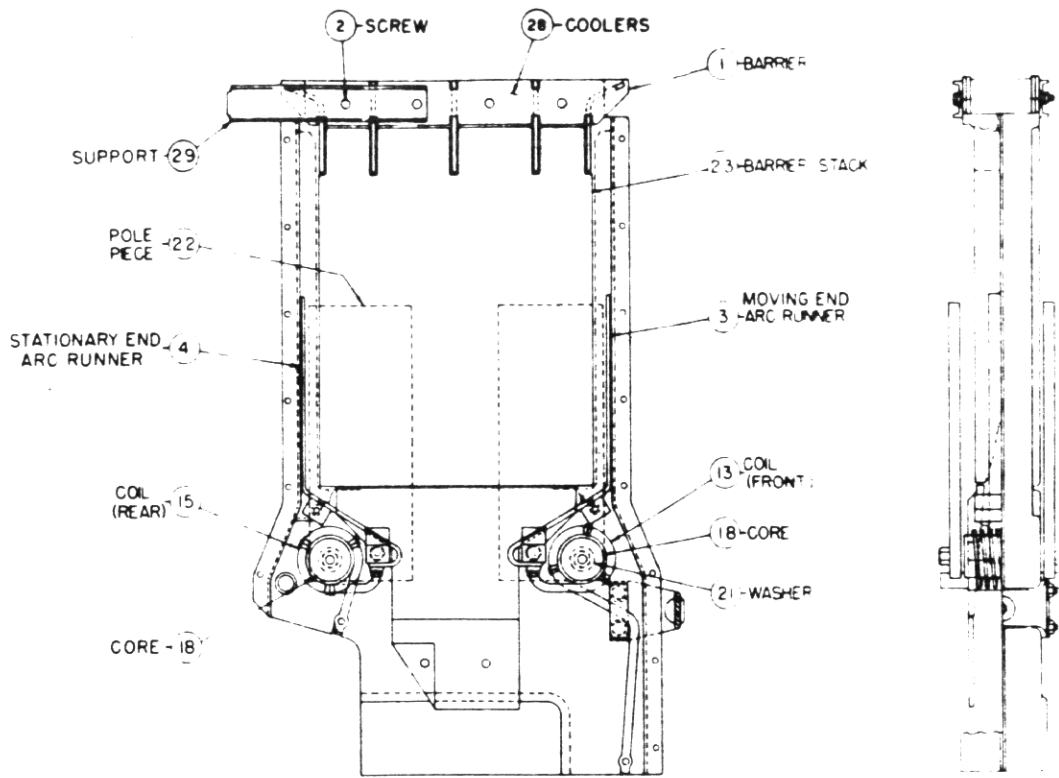

FIG 2 -A
TYPICAL MA-150/250-C ARC CHUTE

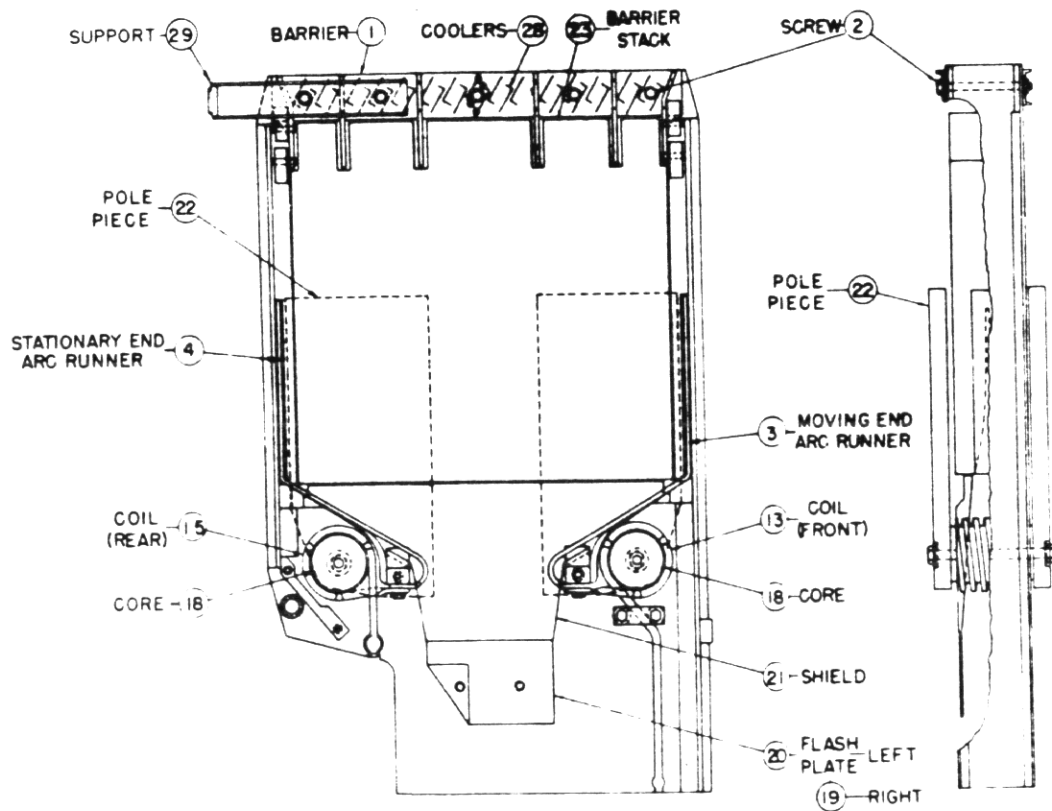

FIG 2 -B
TYPICAL MA-350-C ARC CHUTE

ARC CHUTE ASSEMBLY (Fig. 2A & 2B)

Each arc chute consists of a flame retardent envelope which provides phase isolation for interruption and venting of the by-product gases of interruption. The arc chute contains:

- a) The stationary end arc runner (2-4) and moving end arc runner (2-3) to which the arc terminals transfer from the arcing contacts. The arc runners form paths for the arc terminals to travel up the arc chute.
- b) The stationary end blowout coil (2-15) and moving end blowout coil (2-13) which connect their respective arc runners to the top and bottom bushings. The current in these coils creates the magnetic flux which passes through cores (2-18), pole pieces (2-22), and the space between the pole pieces. The action of this flux on the arc forces the arc up the barrier stack.
- c) The barrier stack (2-23) consisting of a number of refractory plates with "Vee Shaped" slots cemented together. The barrier stack cools, squeezes and stretches the arc to force a quick interruption.
- d) The barrier (2-1) containing coolers (2-28) through which the by-product gases of interruption pass, completes the cooling and de-ionizing of the arc products.

Arc chutes are normally tilted to expose contact area of the breaker and/or to replace parts such as barrier stacks (2-23). The arc chutes may also be removed from breaker by lifting off. The coil connections must be unfastened before tilting or removing.

PHASE BARRIERS (Fig. 1)

Full size barriers of high dielectric flame retardent material isolate each phase.

To remove phase barriers from breakers - lift panel spring assembly (13) out of slots (14) to release panel (32). Lift and remove panel. Remove screws (23), (2), (48), and (49). The phase barrier assemblies can now be lifted and removed from the breaker.

TILTING ARC CHUTES

Remove phase barriers.

On the 5 kv breakers remove screws (1-23) and (1-37) of each phase. Remove screws (1-49) and (1-17) to remove barriers (1-9) and 1-22).

With arc chute support in place, at the rear of the breaker, tilt back the arc chutes.

After tilting arc chutes upright, and replacing barriers, be sure all screws are tightened securely on all three phases.

BARRIER STACKS (Fig. 2)

The barrier stacks are fragile and should be handled carefully. The barrier stacks should be inspected for erosion of the plates in the areas of the slots. The stacks should be replaced when a milky glaze is observed on the full length of the edges of most of the slots. They should be likewise replaced if plates are broken or cracked. When cleaning the breaker and cubicle, inspect for pieces of barrier stack refractory material which would obviously indicate breakage.

To remove the barrier stacks, tilt back the arc chutes, remove screws (2-2), support (2-29), and barrier (2-1), from each arc chute. Slide barrier stack (2-23) through top of arc chute.

When sliding a barrier stack into the arc chute, care should be taken to see that the end containing the "Vee-Shaped" slots goes in first.

INSTALLATION

RECEIVING

Handling

Circuit breakers are shipped from the factory completely assembled. Observe weight markings on crates and ensure that capable handling equipment is used.

Remove crating carefully with the correct tools. Check each item with the shipping manifest. If any shortage or damage is found, immediately call it to the attention of the local freight agent handling the shipment. Proper

notation should be made by him on the freight bill. This prevents any controversy when claim is made and facilitates adjustment.

When writing Allis-Chalmers relative to the equipment, provide the serial number of the circuit breaker, identify parts by instruction manual figure and reference number where possible and give as much detail about the problem as possible.

Storage

Indoor

The circuit breaker should be permanently installed as soon as possible. When storage is necessary, it should be kept in a clean dry place where it will not be exposed to dirt, corrosive gas or mechanical abuse.

Outdoor

When the circuit breakers must be stored outdoors, adequate covering together with a heat source must be provided. The heat source is required to prevent condensation and subsequent corrosion.

CIRCUIT BREAKER PREPARATION

Prepare the circuit breaker for insertion into the cubicle as follows:

1. Free trip latch (breakers are shipped closed with the trip latch blocked or tied).
2. Push manual trip rod to open breaker.
3. Remove phase barriers and tilt arc chutes over support frame.
4. Slowly close breaker and check arcing contacts closing at approximately the same time. (Within 1/16").
5. Trip out breaker and assemble arc chutes and phase barriers.
6. Install plug jumper and energize control. (Springs should charge on stored energy breakers).
7. Close and trip breaker from control switch on panel. (Repeat 2 or 3 times).
8. De-energize control power and remove plug jumper.
9. On stored energy breakers depress foot lever and pull closing lanyard to discharge springs.

OPERATION

Normal

Normal operation of the circuit breaker is controlled by cubicle mounted controls or other control devices.

Manual Closing to Check Contacts

Remove breaker from cubicle and tilt arc chutes back.

On solenoid operated breakers use the manual closing device inserting the pin of the device in the angle bracket mounted on the rear of the breaker with the rolls against the solenoid armature lever the armature in to close the breaker.

The stored energy breaker can be closed slowly and mechanically held in any position of the closing stroke in order to make or check adjustments.

Proceed as follows:

Insert mechanism locking pin into hole at the rear of the operator frame. The pin should pass behind crank and through hole in opposite side of operator frame.

Insert spring charging handle into guide tube and engage with gear motor. Turn handle counterclockwise until resistance is felt.

Pull closing lanyard and hold out, continue turning handle. Contacts will close. Continue turning crank until 4-bar linkage snaps over toggle. Turn crank 10 or 12 additional turns. To open contacts depress trip latch.

NOTE: The breaker can be cranked to any position and held because the motor gears are self-locking.

THEORY OF OPERATION

Type S0-35D Operator

The primary closing force of this operator is supplied by a DC solenoid. The iron circuit which houses the solenoid consists of the main operator frame, to which the pole head is welded, a helically wound tube, and a back plate held in place by four bolts (68). The armature (4), with plunger (6) and cap (19) attached slides in a non-magnetic tube (5). When the coil (8) is energized, the armature moves toward the pole head. The non-magnetic washer (21) keeps the armature from actual contact with the pole head so that the armature will release when the coil is de-energized more rapidly due to the reduced effect of the residual magnetism. The armature is returned by a spring around the plunger.

The operator, thru the use of a four bar linkage, may be electrically and mechanically trip-free by the release of the trip latch mechanically or by energizing the trip solenoid electrically at anytime during the closing stroke or after the breaker is closed.

The four-bar linkage consists of links 70, 101, 102, and 73. In normal closing operation, point E is held fixed between stop bolt 75 and trip latch 27. Plunger 6 moves forward when the closing solenoid is energized rotating link 101 about E as a center. This forces link 102 to move, rotating arm 73 about B its fixed center. The forward travel of point D carries it past prop latch 97 which holds point D as the plunger 6 retracts. The rotation of arm 73 closes the breaker blades and extends the opening springs.

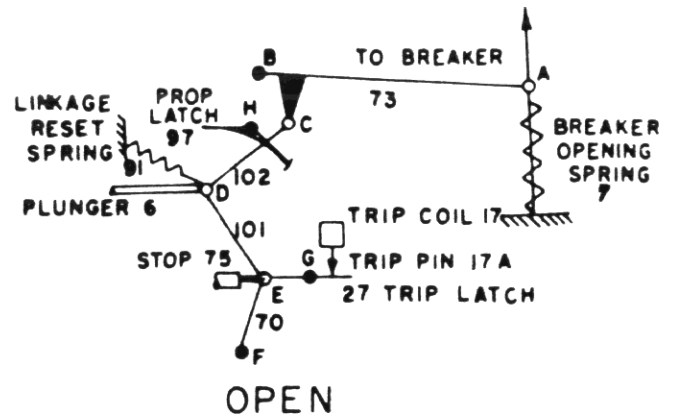

To open the breaker the trip latch 27 is rotated about its center G either electrically by energizing the trip solenoid coil which moves the trip pin down to strike and rotate the latch or by mechanically depressing the tail of the latch. This releases point E, allowing link 70 to rotate about its fixed center F. Links 101 & 102 drop allowing arm 73 to rotate, pulled down by spring 7. As point D drops it is freed from the prop latch 97 and reset spring 91 pulls D back lifting point E back of trip latch 27 and resetting the linkage. If the trip latch 27 is rotated at anytime during the closing stroke, the linkage will collapse.

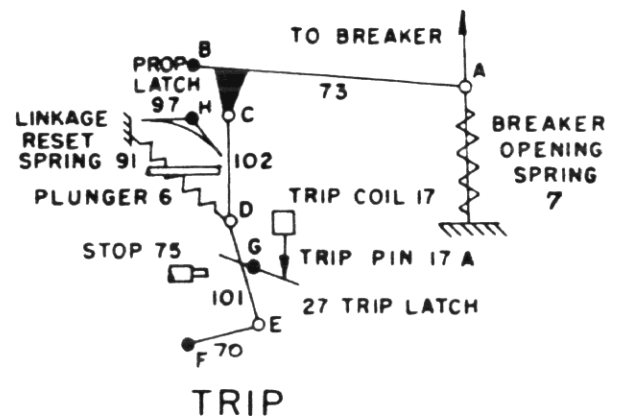
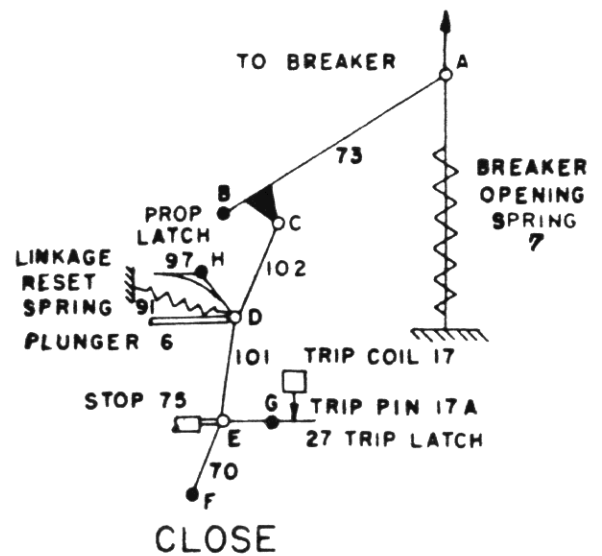

Operator Control - Solenoid

The normal control for this operator has the close power and the control power from a common source. The solenoid used has DC coils designed to give maximum efficiency over the desired control voltage range.

For DC control the normal control method is as shown in Fig. A. When the close contact CS-C is closed, current flow through 52LC and 52Y1 energizes the 52X relay coil. This closes contacts X3 and 52X4 to energize the closing coil 52cc. Contact 52X1 closes to lock in the 52X relay coil. At a point late in the solenoid stroke, the limit switch contact (52aa) closes, energizing the 52Y relay. The closing of the 52Y2 contact locks in the 52Y relay and the opening of the 52Y1 contact cuts off the 52X coil, thereby de-energizing the closing coil by opening the 52X3 and 52X4 contacts and the lock-in circuit of the 52X relay, X1. If the close control remains closed, the 52Y relay is still locked in through 52Y2 contact and must be opened to reset the control for another close. This forms the anti-pump circuit so on a trip-free operation the close control has to be opened before the breaker will attempt another close action.

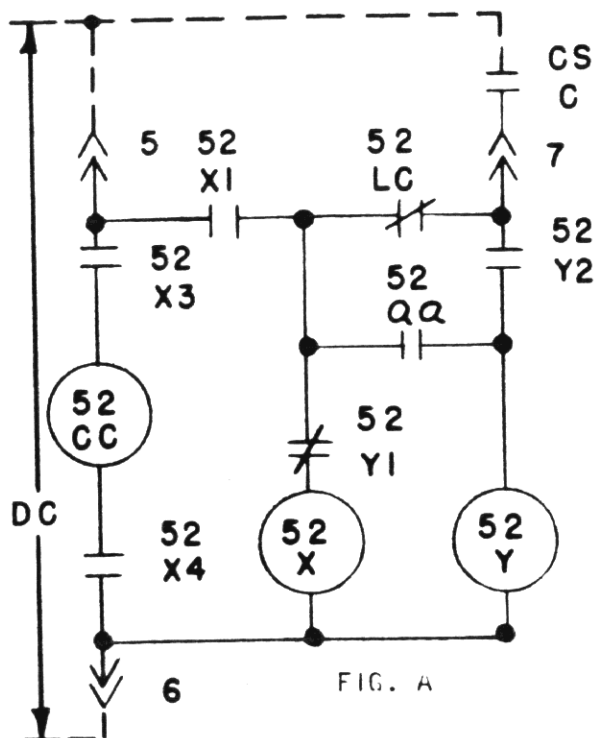

FIG. A

For AC control, a full-wave, bridge rectifier is used to supply DC to the closing coil. An AC control similar to the DC control scheme is shown in Fig. B. The control function is the same as for the DC control. A surge suppressor is furnished across the rectifier to protect against high voltage surges which may destroy the rectifier elements.

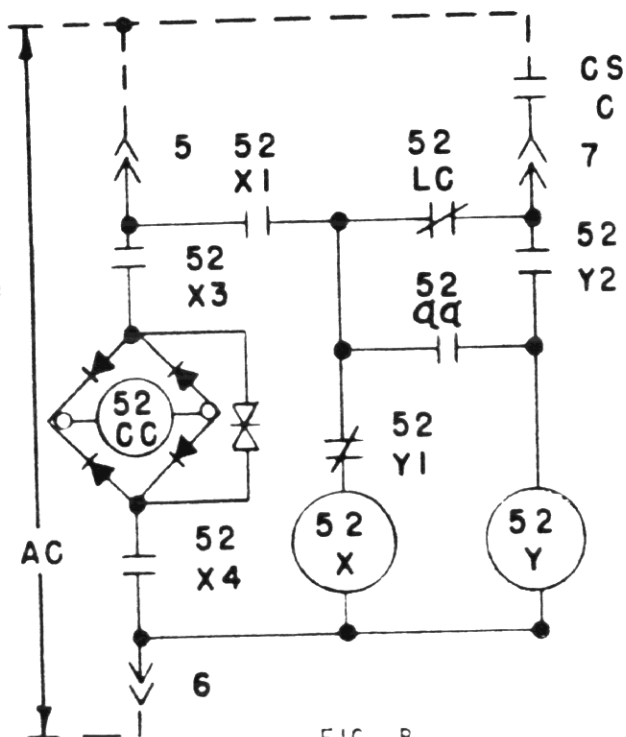

FIG. B

The more commonly used AC control method is the one shown in Fig. C. This method requires a close control with a normally closed contact and a normally open contact. When the supply is energized, the 52Y relay energizes locking in through the 52Y2 contact to terminal No. 5. Contact 52Y4 also closes so that when the close control switch operates, current flow through terminal 7 and 52Y4 energizes the 52X relay which locks in through 52X1 and terminal 5. Relay 52X energizes the close coil circuit through 52X2 and 52X3. At a point late in the solenoid stroke, the limit switch contacts 52bb open de-energizing the 52Y relay. The opening of the 52Y2 and 52Y4 contacts will de-energize the 52X relay, opening contacts 52X1, 52X2, and 52X3 de-energizing the entire circuit. To re-energize the circuit, the 52Y relay must be energized by releasing the close control to re-energize terminal 19. If the breaker is closed, the 52b contact will be open and the 52Y relay will energize when the breaker is tripped open.

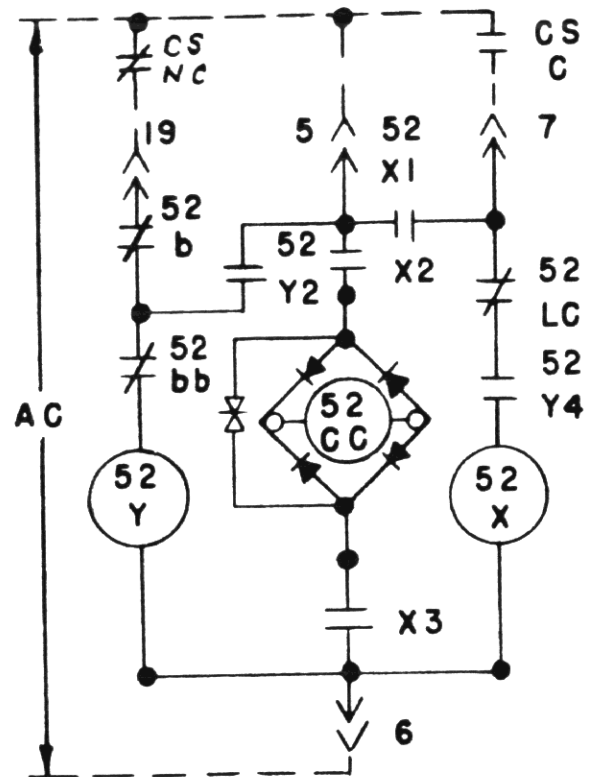

FIG. C

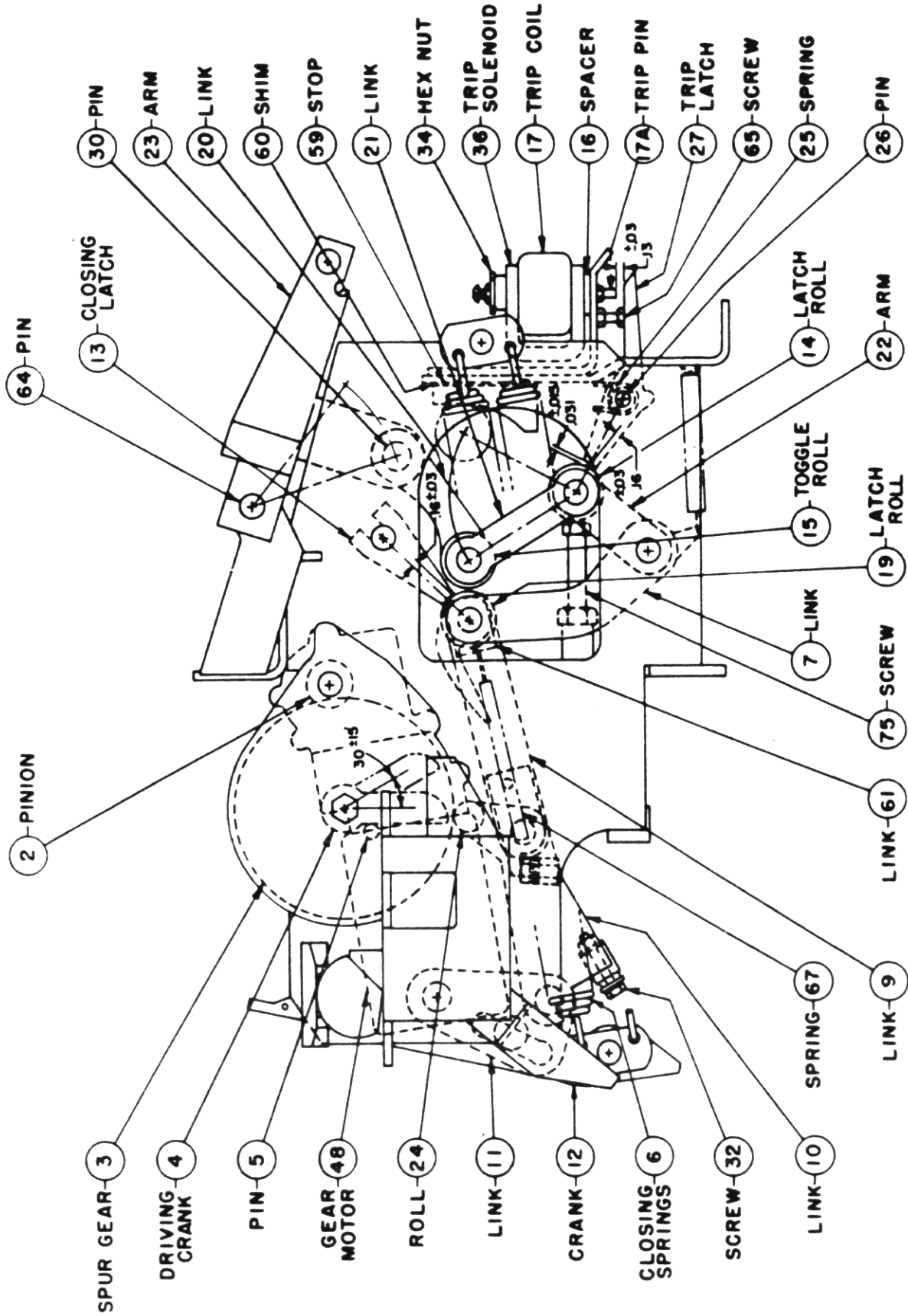

FIG. 4B

THEORY OF OPERATION

Type SE-4 Stored-Energy Operator

Initial conditions of the operator for this discussion are: closing springs released, circuit breaker open and control circuit energized.

The charging motor drives the pinion gear 2 which rotates the spur gears 3. Pin 5 (on the face of the spur gears) engages the free-swinging driving cranks 4 which are rotated into engagement with roll 24.

Continued rotation of cranks forces link 10 down because link 7 is held in place by latch 13. Link 11 rotates about its fixed center. Link 11, through pin 31, drives crank 12 back, extending the closing springs which are attached to the lower end of crank 12.

As the closing springs become fully extended, cranks 4 push links 9 and 10 over toggle and cranks 4 disengage roll 24 and rotate out of the way. The closing springs are fully charged and held by spring release latch 13.

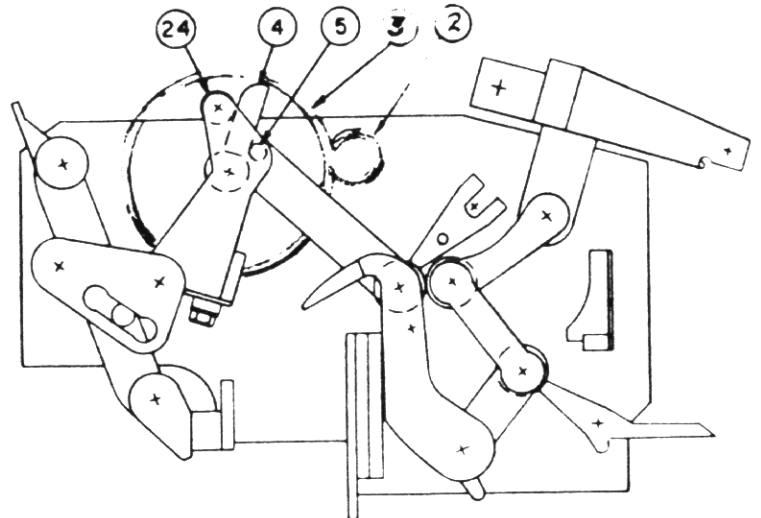

FIG. A

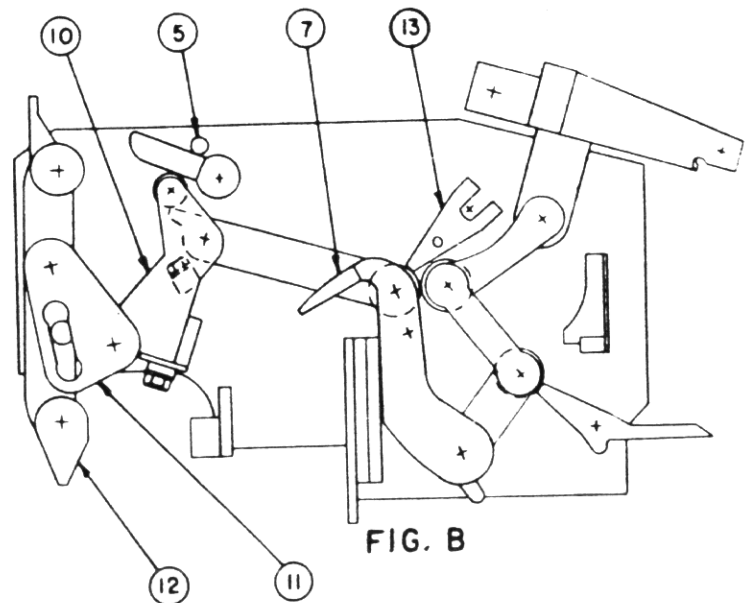
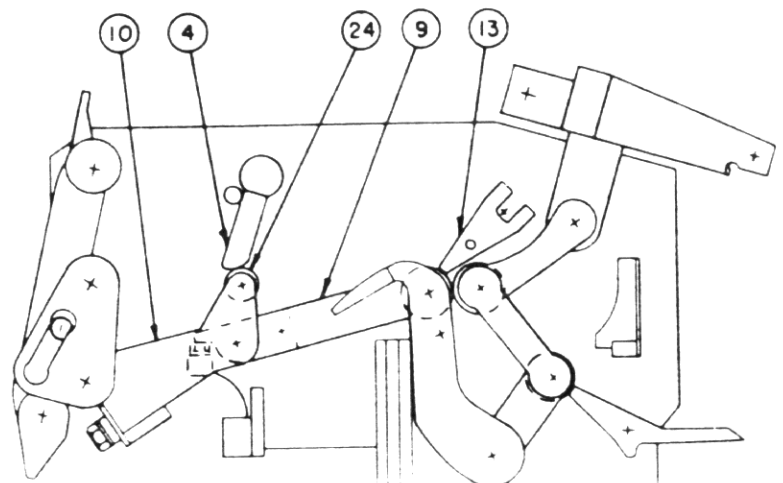
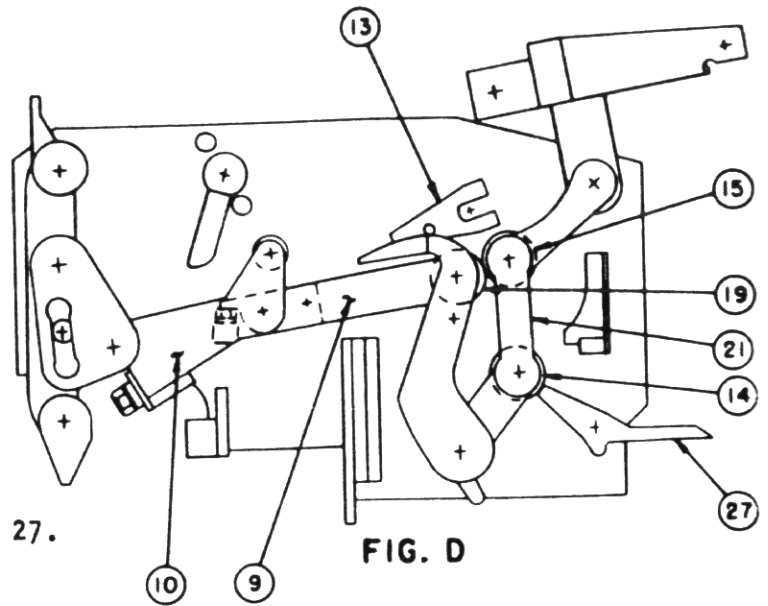

FIG. B



To close the breaker the spring release latch 13 is moved up to release latch roll 19. Links 9 & 10 drive forward as a unit. Latch roll 19 forces toggle roll 15 forward rotating link 21 about latch roll 14 which is held fixed by latch 27.



The rotation of link 21 rotates arm 23, through link 20, closing the disconnect blades. Links 20 & 21 go over toggle against stop 59 locking the breaker closed. Screw 32 and crank 12 come in contact and force link 10 to rotate breaking the over toggle between links 10 & 9.

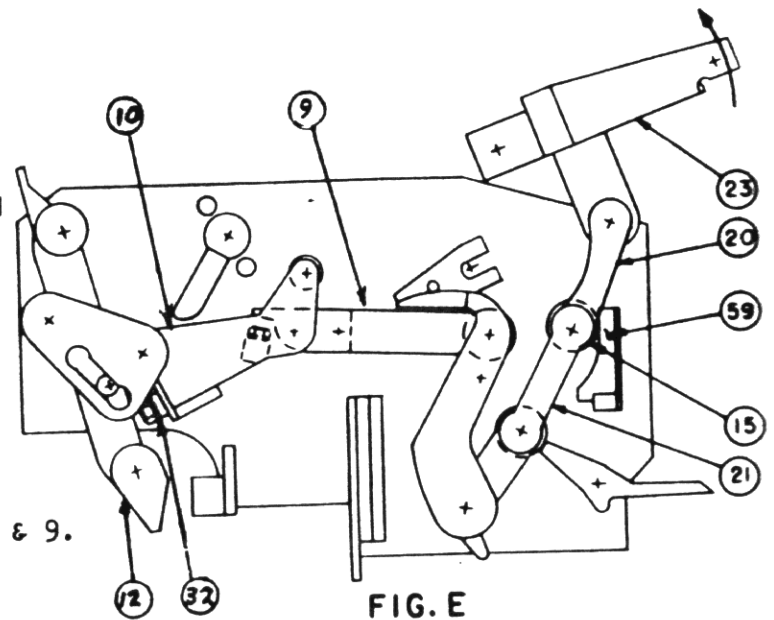

Crank 12 is stopped by the bumper. Link 10 & 9 collapse upward allowing link 7 to reset. Latch 13 drops ahead of latch roll 19. Unit is set to recharge springs.

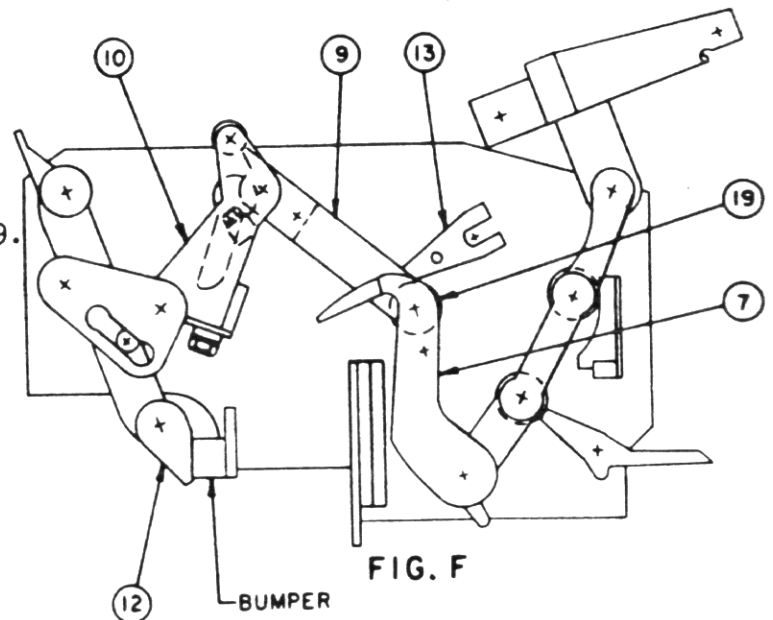

To open the breaker trip latch 27 is rotated by depressing latch tail releasing latch roll 14. Arm 22 rotates about its center allowing links 21 & 20 to drop. This rotates arm 23 about its center opening the breaker. Toggle roll 15 is forced back by the curve of stop 59 breaking the over toggle of links 21 & 20 allowing them to reset. This rotates arm 22 back into reset position with latch roll 14 back of latch 27.

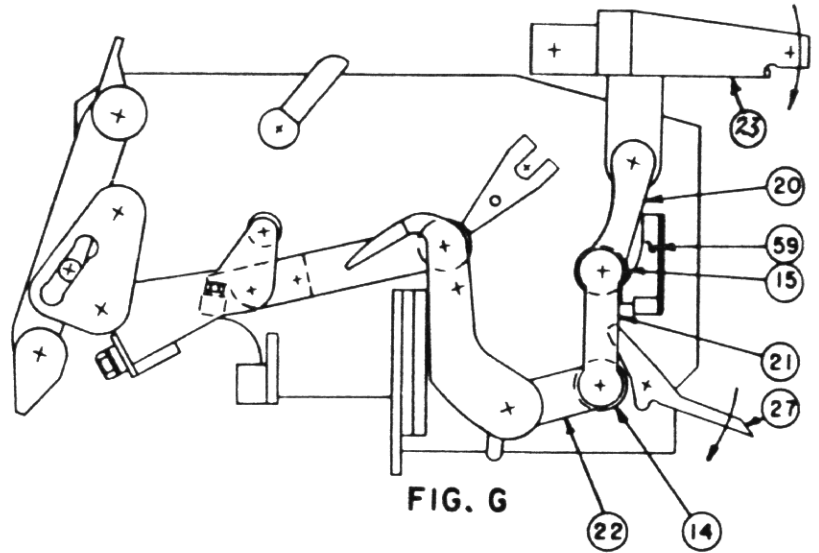

TYPICAL CONTROL SWITCH

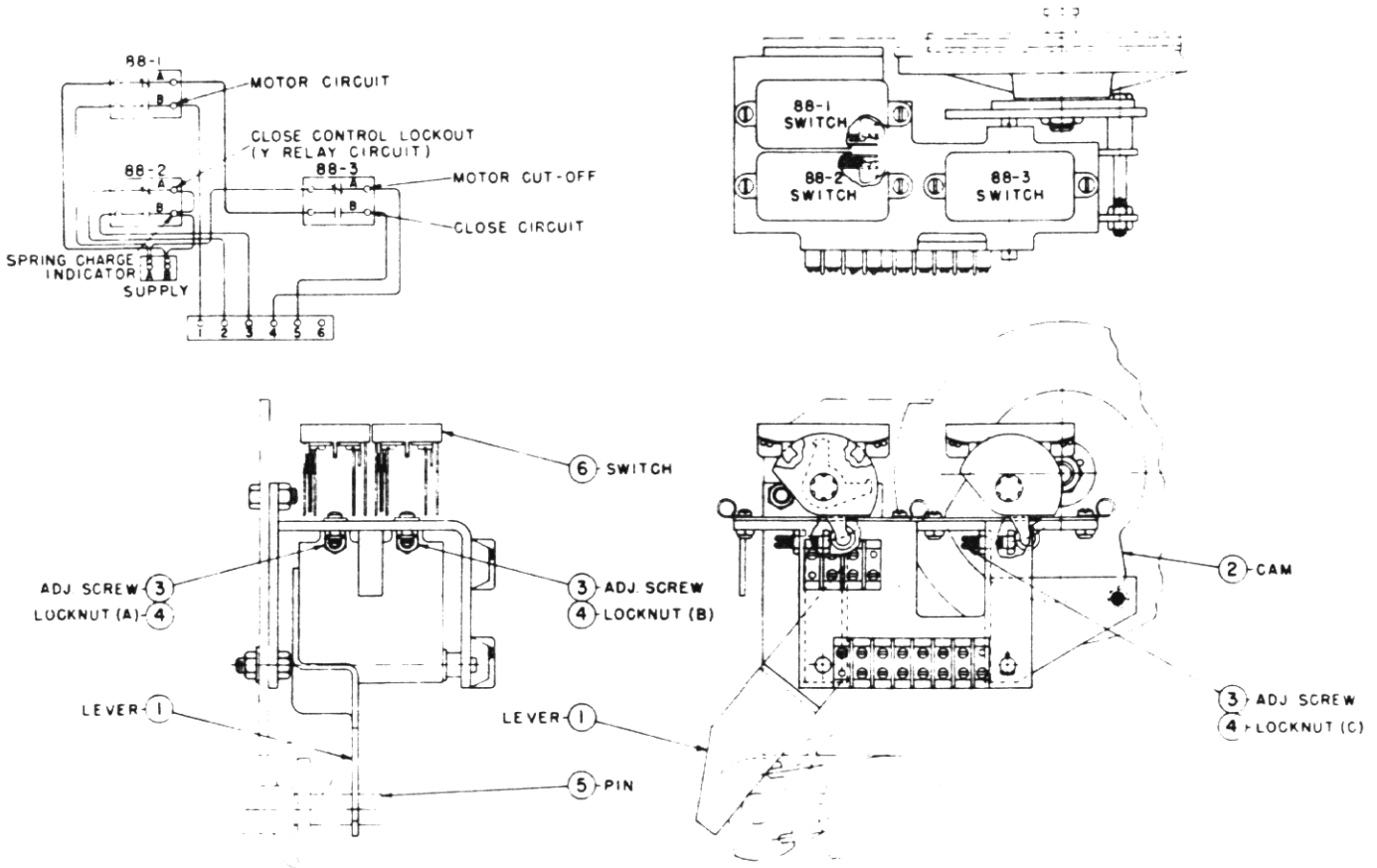

FIG. 8

TYPICAL CONTROL SWITCH

NOV 14, 1967

72-420-020-402

88 Switch Operation

The 88-1NC contact is in the drive motor circuit and is used to start the motor when the springs are discharged and stop the motor when the springs are fully charged. The 88-1NO contact is in the close control circuit and keeps this circuit open until the springs have been fully charged.

The 88-2NC contact is in the close control lockout circuit. The 88-2NO is used to energize an indicating light which shows that the springs are fully charged.

The 88-3NC contact is in series with the 88-1NO contact also holding the close control circuit open. The 88-3NO contact introduces a resistor into the drive motor circuit to coast the drive cranks out of the way with a

Referring to the breaker wiring diagram furnished with the installation, the 88-1 and 88-2 switches are shown with the main closing springs discharged. The 88-3 switch is operated by the cam (2) on the main gear.

As the charging linkage charges the main closing springs, the motor switch cam rotates with the left-hand large gear. Just before the springs are fully charged the cam (2) throws the 88-3 switch and when the springs are fully charged the 88-1 and 88-2 switches are thrown by lever (1) which is operated by pin (5).

To adjust these switches loosen lock nuts (4) and turn adjusting screws (3) in or out with a screwdriver. Proper operation sequence is as follows.

When the control is energized the motor starts to charge the springs. The 88-1b switch opens when the springs are fully charged, however, before this switch opens the 88-3aa switch closes connecting the resistor into the motor circuit. The motor continues to drive the gears until the free swinging cranks on the main gears are almost to the top of the gears. The motor then shuts off (cut by the cam operating the 88-3aa switch), and allows the cranks to go over center, and drop out of the way.

The resistor is adjusted to limit the speed of the unloaded motor. It is factory set to operate the motor at rated and minimum voltage and limit the coast of the motor so that the pin on the gear coasts past top center but not beyond 10 o'clock. With too much resistance the motor will stall. With too little resistance the motor will coast too far and the cam will reclose the 88-3aa switch and the motor will continue to run.

SPRING RELEASE LATCHLOCK

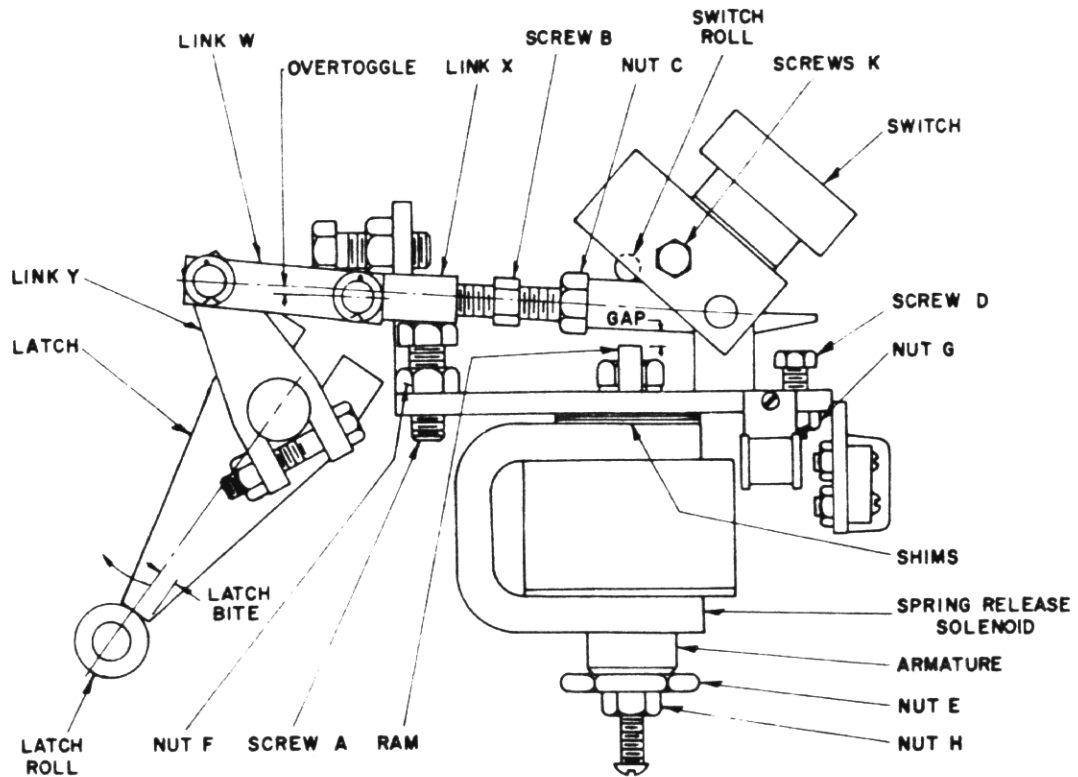
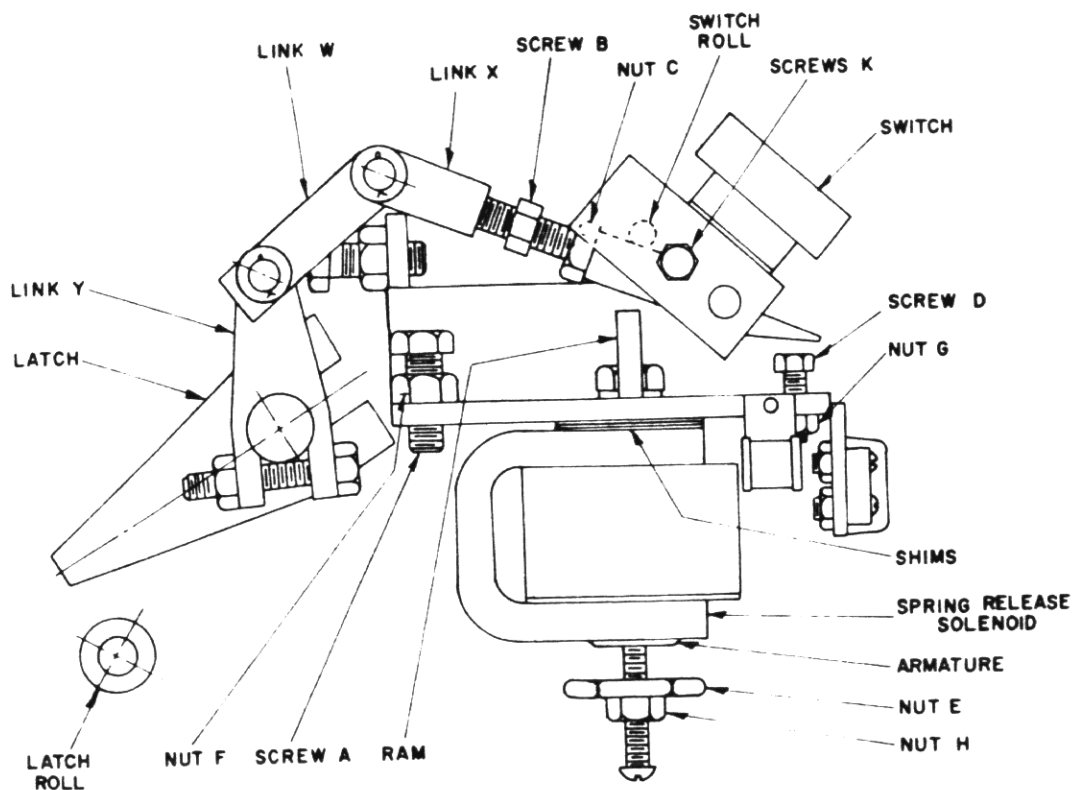

Fig. above shows the spring release latch in the hold position and locked in place by links W and X which are over toggle against screw A.

To release the latch, link X must be moved upward to invert the toggle. The switch shown is in the drive motor circuit and is closed when link X is against screw A. Vertical movement of link X opens the switch.



When the spring release solenoid is energized, the armature moves up with the ram, forcing link X up, to break the over toggle condition of links X and W. Link X is rotated to the right removing the latch from the latch roll, releasing the closing mechanism.

The upward movement of link X opens the switch in the drive motor circuit preventing the springs from charging until link X resets, locking the latch in position.

Operator Control - Stored Energy

The normal control for this operator has been incorporated in one switch assembly located at the rear of the unit. It consists of two heavy duty toggle switches (6) operated by common linkage (1) from the main closing springs and one heavy duty toggle switch (6) operated by a cam (2) driven by the main gear.

The main closing power is supplied through terminals 3 and 4. The mechanical interlock is a switch operated by the breaker release lever which opens the motor circuit when the lever is depressed. The prop latch check switch is closed when the spring release latch is in reset position. The 88-1 and 88-2 switches are shown with the main closing springs discharged. The 88-3 switch is operated by the cam (2) on the main gear. As the charging linkage charges the main closing springs, the motor switch cam rotates with the left-hand large gear. Just before the springs are fully charged, the 88-1 and 88-2 switches are thrown by lever (1) which is operated by pin (5). When the control is energized, the motor starts to charge the springs. The 88-1bb switch opens when the springs are fully charged, however, before this switch opens the 88-3aa switch closes connecting the dropping resistor into the motor circuit. The motor continues to drive the gears until the free swinging cranks on the main gears are almost to the top of the gears. The motor then shuts off (cut off by the cam operating the 88-3aa switch) and allows the cranks to go over center and drop out of the way.

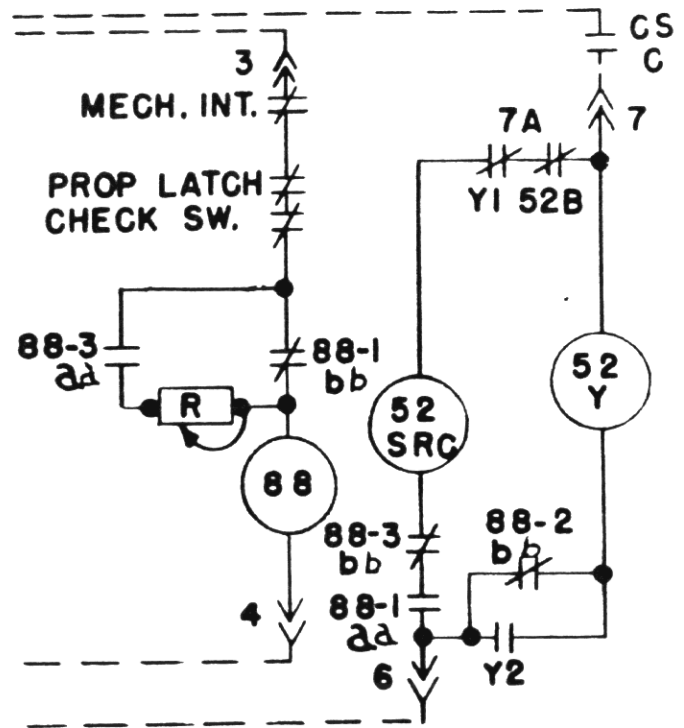

RESET RELAY (For Instantaneous Reclosure Service Only)

The ALLIS-CHALMERS Reset Relay designed for use in circuit breaker control is a rugged electronic solid state time delay which operates a small relay. The relay contacts are rated at 15 amperes.

The relay closing time is not affected by broad variance of voltage and current well beyond the standard circuit breaker control limits. The time delay error caused by temperature is minor being less than 3% from -20°C to $+80^{\circ}\text{C}$ and not over 5% to -40°C .

The voltage regulator and timing circuits are mounted on a printed circuit board and encapsulated in a resilient material for shock resistance.

The controlled supply voltage charges the capacitor (C_1) through the time rate determining resistor (R_1) to the triggering voltage of the unijunction transistor (UJT) which activates the SCR energizing the relay coil.

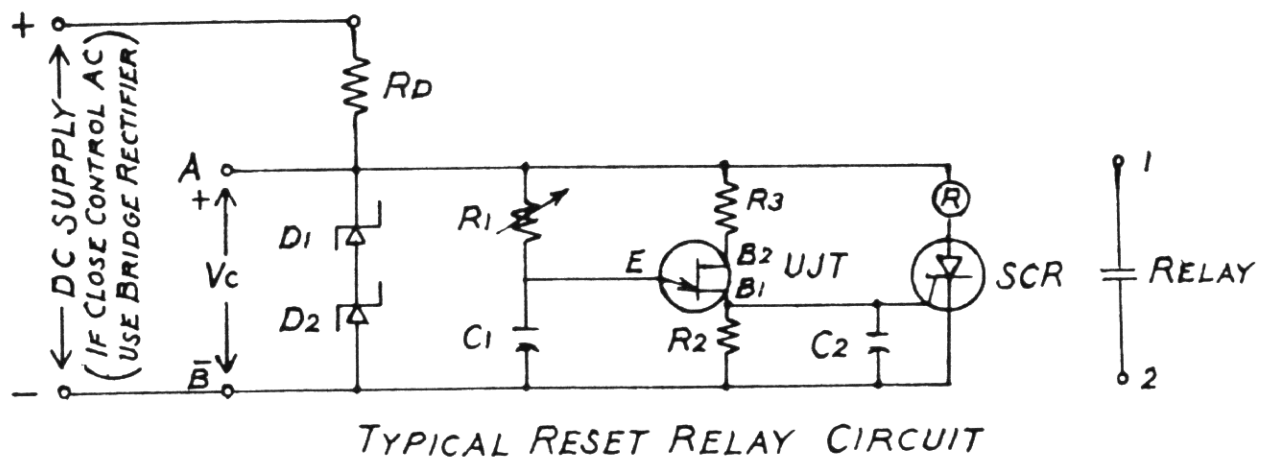

B

A constant voltage V_C is maintained across the terminals AB by the two Zener diodes D_1 and D_2 . Resistor R_D drops the supply voltage to a value above the diode control voltage and the diodes further reduce the voltage to the control voltage value, V_C . The control voltage V_C causes the diodes to conduct and an increase or decrease in supply voltage will produce a corresponding change in the current which causes a change in the voltage drop across R_D equal to the change in supply voltage. To summarize, an increase or decrease in supply voltage will not affect the constant voltage drop V_C across the diodes. Two diodes in series are used because they provide more precise voltage regulation than one diode.

The unijunction transistor (UJT) is a switch which when turned on will allow a short pulse of relatively high current to flow and will then shut off. The terminals EB_1 of the UJT are an open circuit until the voltage at E exceeds a precise level V_F . In other words the UJT does not allow current to flow from point E to point B_1 until the UJT is turned on by the firing voltage V_F . The voltage drop V_C across the terminals AB charges the capacitor C_1 through the variable resistor R_1 . The time that it takes the capacitor C_1 to charge to the firing voltage (V_F) of the UJT is the time delay, and is controlled by the variable resistor R_1 .

R_1 is preset in the factory for a delay of ten cycles and locked in place by the stem locking nut. A 5° change in resistor setting would mean a change in delay of approximately $\frac{1}{2}$ cycle. The unit is adjustable from an

approximately instantaneous to a 60 cycle delay. Any readjustment should be made using a cycle counter or equivalent for timing.

When the voltage drop across the capacitor and therefore at point E, exceeds V_F , the terminals EB₁, act as a short circuit and the UJT discharges the capacitor through R₂ and the gate terminal of the silicon controlled rectifier (SCR). That is, the UJT allows current to flow from the capacitor at point B₁ and into the gate terminal of the SCR.

The SCR is a latch type switch. Normally it blocks the flow of current through the relay R. When the gate terminal receives a current pulse from the capacitor discharging through the UJT, the SCR allows current to flow through the relay R. The SCR conducts even after the pulse is removed. The relay contacts R close allowing current to flow through the spring release coil circuit.

The gate terminal of the SCR is protected from random high frequency pulse by capacitor C₂ which provides a short circuit to ground for these pulses. In other words the reactance of the capacitor C₂ is negligible at high frequencies and the capacitor allows current to flow through it.

The delay circuit in the reset relay is a closely controlled capacitor relaxation circuit, direct current operated. When used on a breaker with DC control, the circuit is as shown. When the close control switch is closed, the circuit from 7 through 52B, Y1, to terminal 4 and from terminal 3 to 6 energizes the time delay circuit. After the specified delay, normally ten cycles, the relay coil is energized closing the relay contact tying terminal 7B to terminal 7C completing the circuit to the spring release coil and closing the breaker.

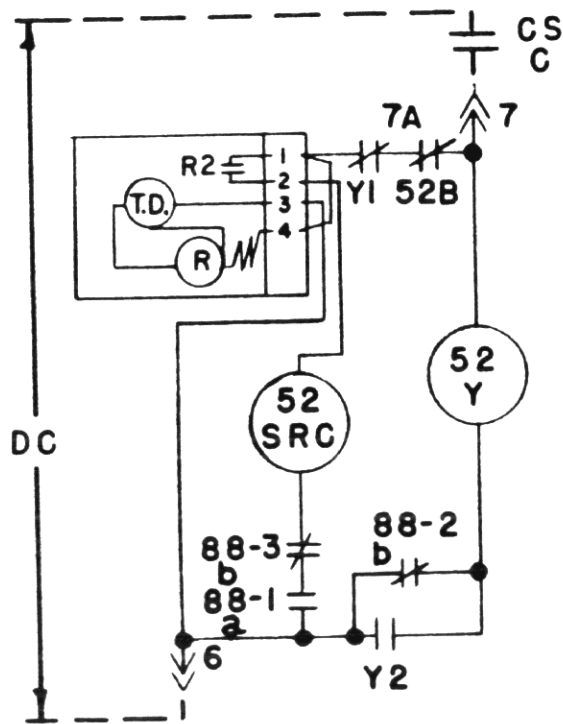

When used with an AC closing circuit, a full-wave, bridge rectifier is used to supply DC to the delay circuit. The circuit is as shown in Fig. D. The input to the rectifier is 7B and 6. The DC output through terminals 3 and 4 supply the time delay circuit of the reset relay.

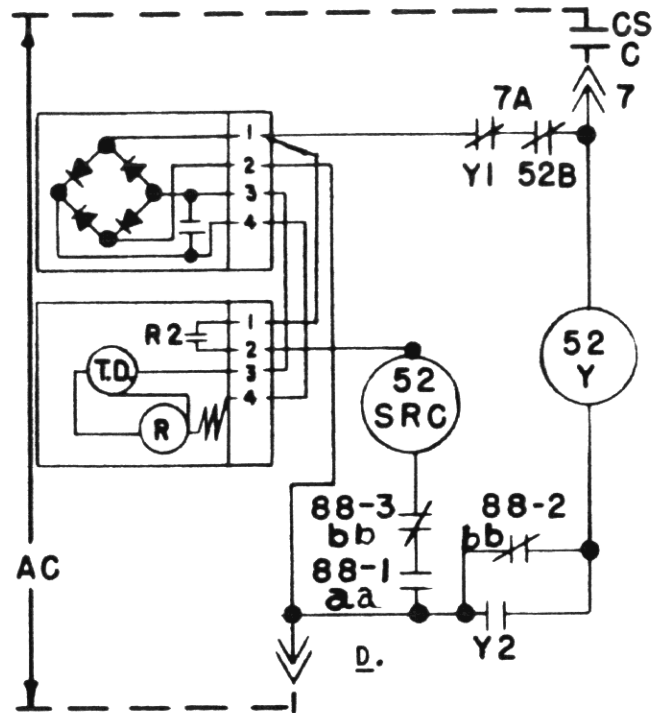

MAINTENANCE

LUBRICATION

At present, a tube of "Aero Lubriplate" is supplied with the cubicle accessories for use as a cubicle disconnect contact lubricant to increase silver plating life. This lubricant must not be used on any part of the circuit breaker. The following procedures should be used:

Thorough inspection at periodic intervals is important to satisfactory operation. Conditions affecting maintenance are weather and atmosphere, experience of operating personnel, and special operation requirements. The frequency of inspection and maintenance will, therefore, depend on installation conditions and can be determined only by experience and practice.

When lubrication is necessary, all purely mechanical joints should be given a light film of BEACON P-290 grease (a product of Beacon Oil Company, a subsidiary of Humble Oil Corporation). All current carrying joints should be inspected to be sure all contact surfaces are free of protrusions or sharp changes of plane. Rub microfine graphite well into all contact surfaces and remove any excess.

CAUTION

Do not get graphite on insulation as it cannot be removed and insulation must be replaced if contaminated with graphite.

Needle bearings are packed with a special lubricant and should require no further attention. Bearing pins and other sliding or rotating areas should be wiped with a thin film of BEACON P-290 grease (a product of Beacon Oil Company, a subsidiary of Humble Oil Corporation). Greasing should be done with care because excess grease tends to collect foreign matter which in time may make operation sluggish and affect the dielectric strength of insulating members.

Beacon P-290 grease may be purchased through Humble Sales Offices in Los Angeles, California; Oak Brook, Illinois; Baltimore, Maryland; Pelham, New York; Charlotte, North Carolina; Memphis, Tennessee; Dallas and Houston, Texas.

The Allis-Chalmers Boston Plant has a stock of this grease in one (1) pound cans under the part number W-962-011.

ADJUSTMENTS

All breaker adjustments are factory set and precisely checked before and after numerous mechanical operations on every breaker to insure correctness of the adjustments. No adjustment checking should be necessary on new breakers. If a malfunction occurs, check for hidden shipping damage.

The following section is to assist in obtaining the correct adjustments when replacing a broken or worn part.

Circuit Breaker Timing

A comparison of circuit breaker timing at any period of maintenance with that taken when the circuit was new will indicate the operational condition of the circuit breaker mechanism. A time variance of more than $\frac{1}{2}$ cycle on opening and 2 cycles on closing indicates a maladjustment or friction buildup. A hole in the movable contact arm is for connection of a speed analyzer.

Arcing Contact Hinge Joint

See Fig. 3. The arcing contact hinge joint is properly adjusted when the spring washers (15) are deflected approximately 0.015 inches.

Adjust by tightening nut (4) until all parts just touch, then tighten nut $\frac{3}{4}$ to 1 turn more.

Hinge Joint Contact Pressure

See Fig. 3. The hinge joint contact pressure is properly adjusted when a pull of 7 to 9 pounds is required to move the disconnect toward the open position. Adjust as follows:

1. Remove pin (12) and detach link (8) from the disconnect arms (18) and (19).
2. Move the disconnect to a position just short of "contact make".
3. Attach a spring scale to the disconnect $8\frac{1}{2}$ inches above screw (24), and in a direction perpendicular to the longest edge of the disconnect arm.
4. Measure the amount of pull required to move the disconnect toward the open position.
5. Tighten or loosen nut (14) as required.

NOTE: Before attaching link (8) to disconnect arms (18) and (19), check contact alignment and contact lead.

Contact Alignment

See Fig. 3. The primary disconnect contacts are an integral part of the bushing assemblies and are aligned with the upper and lower bushings at the factory. No further adjustment should be necessary. The horizontal pairs of main contact fingers in each phase should 'make' with the moving contact simultaneously.

NOTE: Contacts on different phases do not have to mate simultaneously, they can vary as much as 1/32 of an inch.

Check alignment of MA-75C circuit breakers as follows:

1. Detach arcing contact (10) from yoke (2) by removing pin (26).
2. Move disconnect toward the closed position until it just touches a main contact finger as shown in view AA main contacts engaging. Dimension c should be no greater than 0.020 inches, with one contact touching.
3. Align if required.

Check alignment of MA-250C & 350C circuit breakers as follows:

1. Remove pin (12) and detach link (8) from disconnect arms (18) and (19) of two phases only.
2. Move the disconnect contacts of the remaining phase toward the closed position with the maintenance closing device until a main contact finger touches as shown in view AA main contacts engaging. Dimension c should be no greater than 0.020 inches.
3. Align if required.

Align contact as follows:

1. Loosen nuts (22) and rotate stationary contact assembly to set clearance.
2. Tighten nuts (22) and check clearance.
3. Align and check each phase separately.

NOTE: Be sure there are no binds between contacts which may prevent proper wiping action with the disconnect arms.

4. Attach arcing contact (10) to yoke, if detached, but check contact lead before attaching link () to disconnect arms.

Contact Lead

See Fig. 3. Contact lead is adjusted at the factory and should not require adjustment.

The arcing contacts should "make" before the main contacts. Check and adjust each phase separately as follows:

1. Remove pin (12) to detach link (8) from disconnect arms (18) and (19), if not already detached.
2. Move disconnect toward closed position until arcing contacts just touch.
3. The shortest gap between the bottom contact fingers and the contact on the disconnect arms should be $7/32$ to $1/4$ inches.
4. Adjust nut (1) for proper clearance.

Contact Stroke

See Fig. 3. To ensure proper wiping action and contact pressure, the contact stroke must be maintained. Do not check contact stroke unless the contacts are properly aligned.

Latch breaker and check the spread of the top pair of fingers. They should spread $1/8$ " to $3/16$ " (The increase of a & a').

Adjust as follows:

1. Open breaker.
2. Increase (or decrease) the effective length of link (8) by adjusting the nuts on the yoke end at the lower end of link (8).

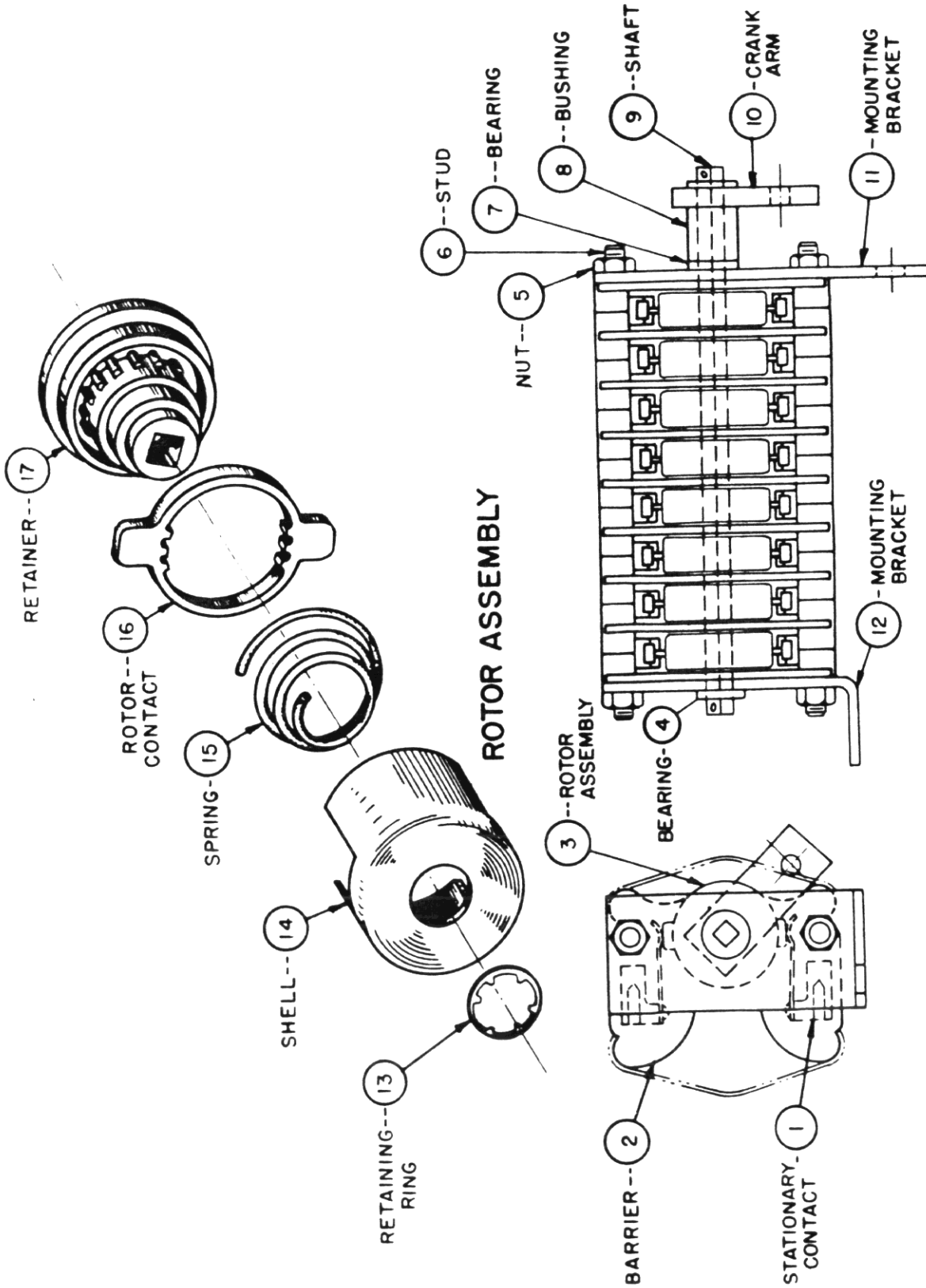

FIG. 11
TYPICAL AUXILIARY SWITCH
 JULY 16, 1958
 71-301-758

Auxiliary Switch.

See Fig. 11. The Q10 auxiliary switch used on these breakers has been tested and adjusted at the factory and should not require further adjustment of those contacts used in the breaker control circuit.

The switch is designed so that the individual contacts may be repositioned in fifteen degree steps without disassembling the switch.

To reposition the contact move the rotor contact (16) in the slot of the shell (14) compressing spring (15). This will free the rotor from the retainer (17). Rotate the rotor to the desired position and release. Be sure the rotor springs solidly back against the retainer to fully engage the rotor and retainer teeth.

Solenoid Operator.

Latch Roll Clearance.

With the breaker open and the latch roll (15A) resting against screw (75) the latch roll should clear the trip latch (27) by $1/64$ to $3/64$ ". Adjustment is made by screw (75).

Trip Latch

The trip latch (27) should engage the latch roll (15A) $1/8$ to $3/16$ of an inch above the lower edge of the latch face with the breaker closed. Adjust screw (65) for proper engagement.

NOTE: This adjustment offsets the clearance between trip pin and trip latch. Refer to tripping solenoid adjustment.

The trip latch should clear the latch roll by $1/64$ to $3/64$ of an inch with the breaker open. Adjust screw (75) for clearance.

Trip Solenoid

The trip solenoid is adjusted by shims so that when the armature is against the pole head there is $1/32$ " to $3/32$ " travel after the breaker trips.

The trip pin (17-A) clears the trip latch (27) when relaxed by $3/32$ " to $5/32$ ". Adjustment is by hex nut (76).

Prop Latch

The prop latch is adjusted by shims so that it engages the toggle roll (15) $1/8$ to $3/16$ " above the lower face of the latch.

Limit Switch

The limit switch is located on the front of the operator frame and is contacted by an extension of the toggle roll pin within the 4-bar toggle linkage.

Adjust by screw (103). Contact action required by circuit should be at $3/4$ to $7/8$ stroke of ram cap (19).

Latch Check Switch

The latch check switch is mounted on the bottom of the operator frame. The switch makes contact near the end of the reset travel of the lower link of the 4-bar toggle linkage.

Adjust by moving switch bracket (66).

NOTE: The latch check switch may be jumper wired out or omitted if not used for instantaneous reclose.

Stored-Energy Operators

Toggle Roll

See Fig. 4B. The current adjustment of the toggle roll (15) is as follows:

1. Breaker closed.
2. Toggle roll against stop (59).
3. Center of toggle roll should be $3/16$ to $5/16$ inch beyond centers of lower latch roll (14) and pin (30).
4. Add or remove shims (60) behind stop (59) to adjust.

Trip Solenoid

The trip solenoid is adjusted by shims so that when the armature is against the pole head there is $1/32''$ to $3/32''$ travel after the breaker trips.

The trip pin (17-A) clears the trip latch (27) when relaxed by $3/32''$ to $5/32''$. Adjustment is by hex nut (34).

Trip Latch

See Fig. 4B. The trip latch should engage the latch roll $1/8$ to $3/16$ of an inch above the lower edge of the latch face with the breaker closed. Adjust screw (65) for proper engagement.

NOTE: This adjustment offsets the clearance between trip pin and trip latch. Refer to tripping and closing solenoid adjustment.

The trip latch should clear the latch roll by $1/64$ to $3/64$ of an inch with the breaker open. Adjust screw (75) for clearance.

Motor Resistor

The motor resistor is added to the motor circuit to limit the speed of the unloaded motor. Adjust the resistor to limit the coast of the motor so the pin on the gear coasts past top center but not beyond 10 o'clock.

Too much resistance will cause motor stalling while too little will allow the motor to coast too far and the cam may reclose the 88-2a switch.

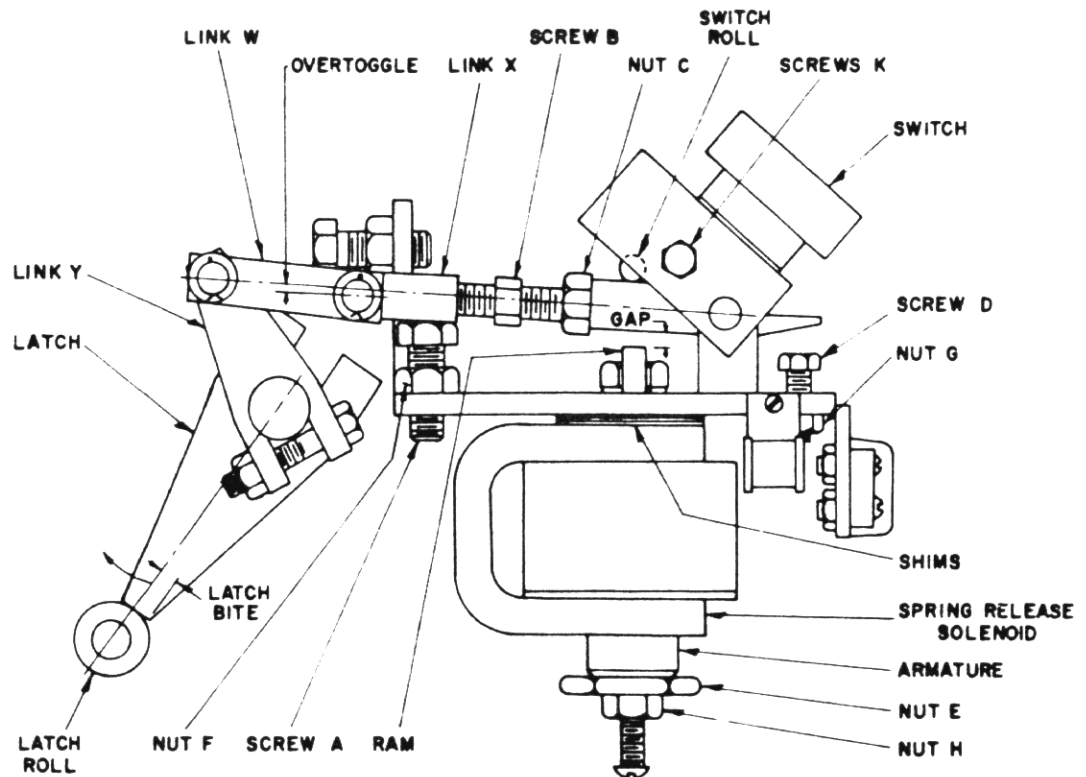

1. Link W and link X are over toggle by $1/32''$ to $1/16''$. Set by screw A.
2. Latch bite is $1/8''$ to $3/16''$. Set by screw B. (Turning screw B clockwise from switch end increases latch bite).
3. Switch must be open when link X is raised and close when links W and X form a straight line. (To set switch loosen (2) screws (K). With a $1/16''$ shim between screw A and link X depress switch until it opens (if necessary raise link X slightly) then slowly raise switch until it closes. Lock in place with screws K).

SPRING DISCHARGE

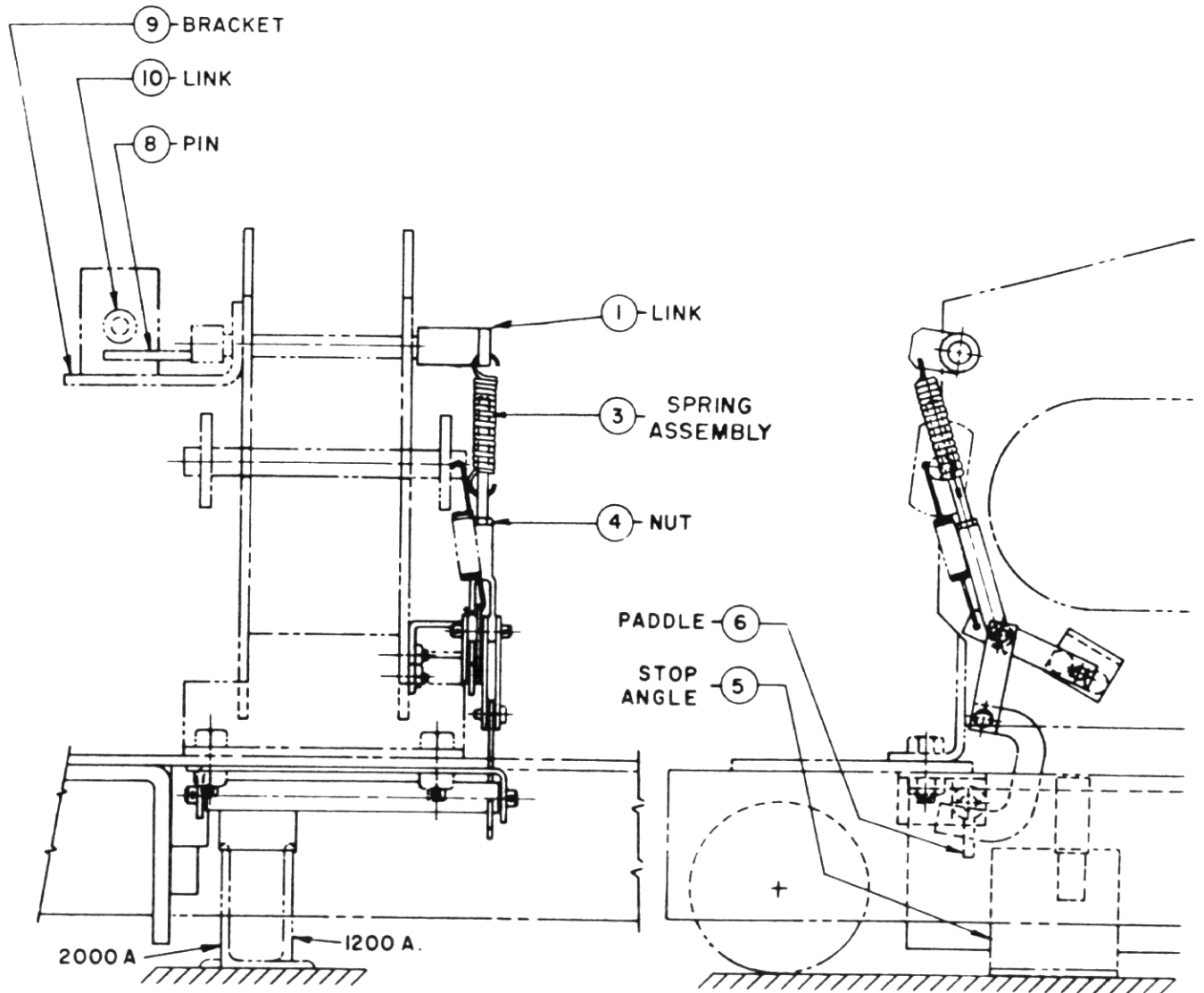

When the breaker enters or leaves the cubicle, the paddle (6) passes over the stop angle (5). Deflection of the paddle (6), thru spring assembly (3) pulls down on link (1) raising pin (8) which lifts link X (of the over toggle latch lock) releasing the closing springs.

Adjustment is by the length of spring assembly (3) thru the clevis at the lower end.

CONTROL SWITCH

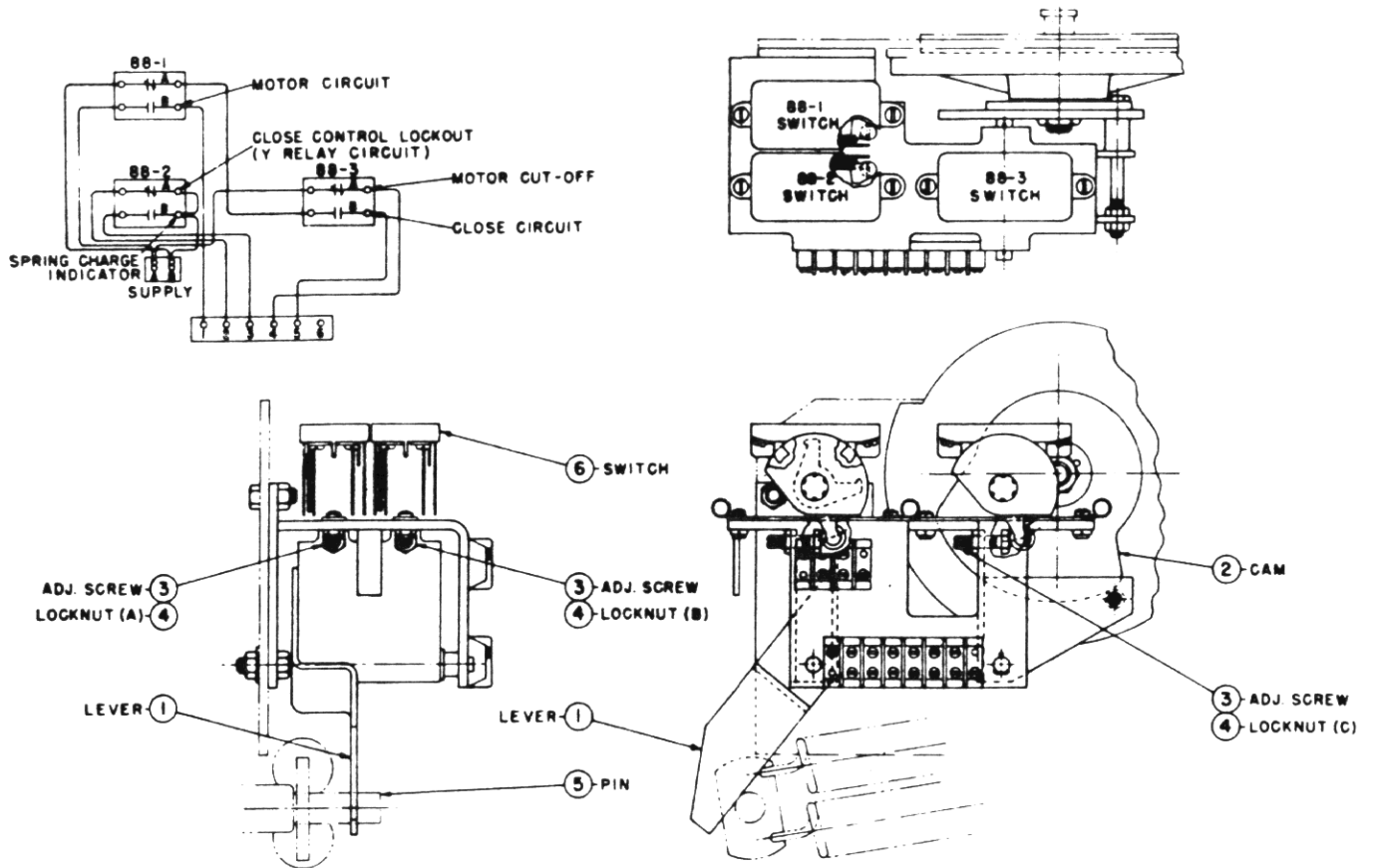

To adjust - With the hand crank, rotate the gears in charging direction until roller of 88-3 rests on the crown of cam (2). Adjust the switch by screw (3) to allow $1/32''$ to $1/64''$ over travel.

Continue charging the springs until 88-3 switch throws (near full charge). Adjust 88-1 and 88-2 switches by screws (3) to snap over.

Discharge Springs - Recharge springs, by hand crank, and readjust 88-1 and 88-2 switches to throw with or after 88-3.