



IL 33-DRC-1

**Retrofit System for Westinghouse and Cutler-Hammer
DS Power Circuit Breakers**

Table of Contents

SAFETY PRECAUTIONS 1

How to Use this Manual 2

Work Sequence 2

Figure 1 Work Sequence 3

Tools and Equipment Required 4

Figure 2 Sample Pick List 4

Section 1 Breaker Preparation 5

1.0 General Breaker Preparation 5

2.0 Removing the Trip Unit 5

2.1 Removing the Original Amptector Trip Unit Assembly 5

2.2 Removing the Original Digitrip RMS Trip Unit Assembly 6

3.0 Removing the Wire Guide 6

4.0 Removing the Existing Overcurrent Trip Switch (OTS)..... 7

Section 2 Installing the Wiring Guide 8

Section 3 Installing the Power Relay Module (ATR) Assembly 9

Section 4 Installing the Potential Transformer (PT) Module 11

Section 5 Installing the Communications Wiring Harness 13

**Section 6 Installing the Mounting Frame Assembly, Trip Unit,
and Rating Plug 14**

Section 7 Installing the Auxiliary (Aux.) Switch Assembly 18

**Section 8 Installing the Breaker Mounted Control Power
Transformer (CPT)..... 20**

Section 9 Installing the Direct Trip Actuator (DTA) 23

Section 10 Installing the Overcurrent Trip Switch (OTS) 26

Section 11 Modifying the Breaker Faceplate 28

Section 12 Installing the External Harness 31

Section 13 Installing the Sensors 33

Section 14 Testing the Breaker 35

Section 15 Installing the Cell Harness Assembly 36

BF Addendum..... 38

Torque Values for General Mounting 39

Index 41

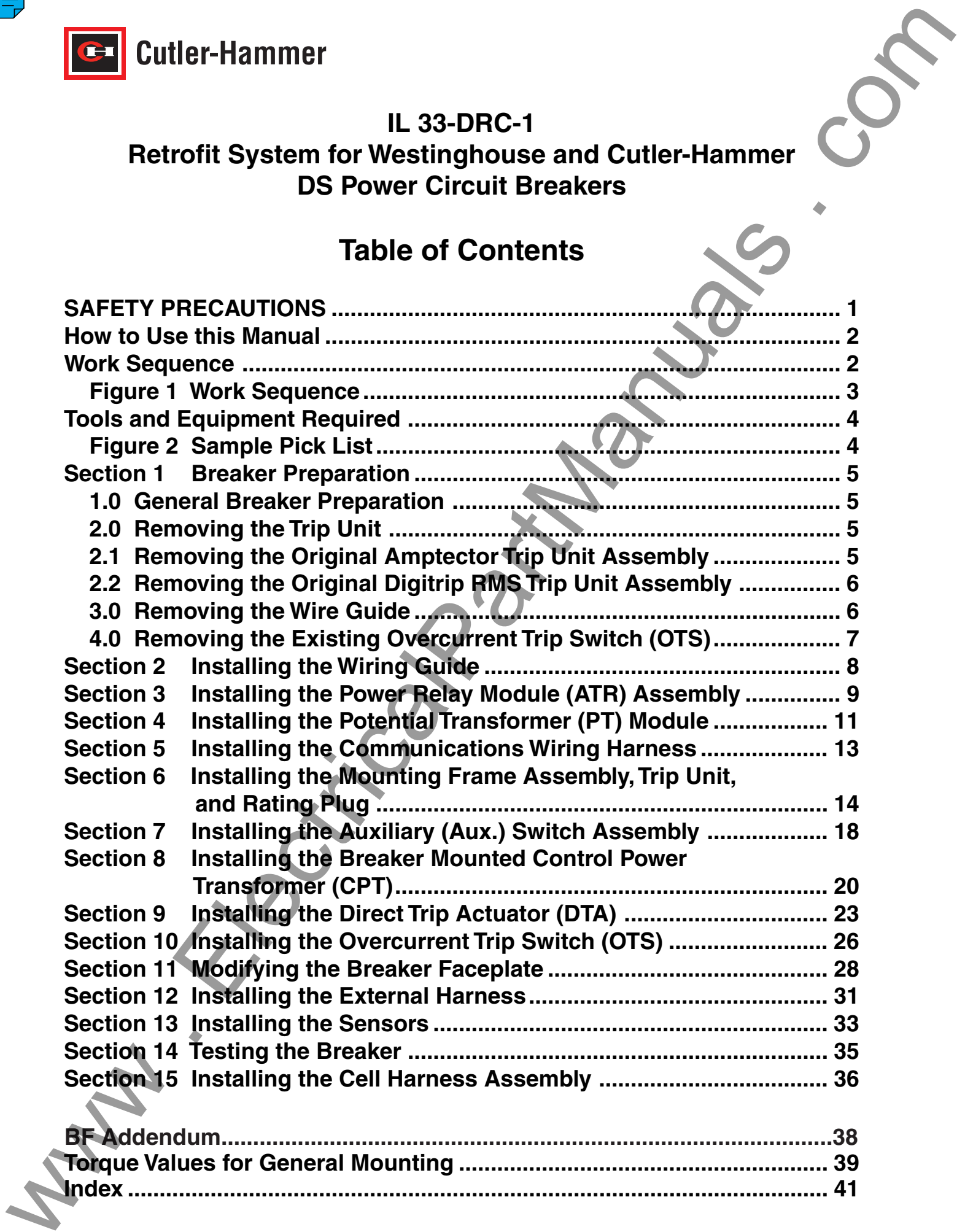



Retrofit System for Westinghouse and Cutler-Hammer DS Power Circuit Breakers



- Completely read and understand all instructions before attempting any installation, operation, maintenance, or modification of these breakers.
- **Always turn off and lock out the power source feeding the breaker prior to attempting any installation, maintenance, or modification of the breaker. Do not use the circuit breaker as the sole means for isolating a high voltage circuit. Follow all lockout and tagging rules of the National Electric Code and all other applicable codes, regulations, and work rules.**
- Do not work on a closed breaker or a breaker with the closing springs charged. Trip (open) the breaker and be sure the stored energy springs are discharged before performing any work. The breaker may trip open or the charging springs may discharge, causing crushing or cutting injuries.
- For drawout breakers, trip (open), and then remove the breaker to a well-lit work area before beginning work.
- Do not perform any maintenance: including breaker charging, closing, tripping, or any other function which could cause significant movement of the breaker while it is on the extension rails. Doing so may cause the breaker to slip from the rails and fall, potentially causing severe personal injury to those in the vicinity.
- **Do not leave the breaker in an intermediate position in the switchgear cell. Always leave it in the connected, test, or disconnected position. Failure to do so could lead to improper positioning of the breaker and flashover, causing death, serious personal injury, and / or property damage.**
- **Do not defeat any safety interlock. Such interlocks are intended to protect personnel and equipment from damage due to flashover and exposed contacts. Defeating an interlock could lead to death, severe personal injury, and / or property damage.**

SAFETY PRECAUTIONS



WARNING

POWER CIRCUIT BREAKERS ARE EQUIPPED WITH HIGH SPEED, HIGH ENERGY OPERATING MECHANISMS. THE BREAKERS AND THEIR ENCLOSURES ARE DESIGNED WITH SEVERAL BUILT-IN INTERLOCKS AND SAFETY FEATURES INTENDED TO PROVIDE SAFE AND PROPER OPERATING SEQUENCES. TO PROVIDE MAXIMUM PROTECTION FOR PERSONNEL ASSOCIATED WITH THE INSTALLATION, OPERATION, AND MAINTENANCE OF THESE BREAKERS, THE FOLLOWING PRACTICES MUST BE FOLLOWED. FAILURE TO FOLLOW THESE PRACTICES MAY RESULT IN DEATH, PERSONAL INJURY, OR PROPERTY DAMAGE.

- Only qualified persons, as defined in the National Electric Code, who are familiar with the installation and maintenance of power circuit breakers and their associated switchgear assemblies should perform any work associated with these breakers.

How to Use this Manual

This manual includes information on the Retrofit process for all former Westinghouse and new Cutler-Hammer DS Power Circuit Breakers.

It is divided into two distinctive sections. The first section contains general information and instructions for preparing the Breaker for the Retrofit process. It includes instructions for removing components common to most DS Breakers.

The second section contains detailed instructions for installing each component available for Retrofitting DS Breakers. The Retrofitter should note that only the instructions that apply to the specific Retrofit being performed (refer to the Pick List supplied with the kit and the "Work Sequence" section in Figure 1) should be followed. This approach was necessary because of the variety of Breakers in the DS family, as well as the number of Retrofit options available.

The instructions are keyed on both the **Style Number** of each component and the **"Family" photograph** showing all parts included with the component. The parts used in each procedure are highlighted within the photographs. Keep in mind while reviewing the instructions and components that the Retrofit kit may contain parts that are not required for your particular application (i.e.: extra bolts, washers, wire ties, etc.).

Throughout the Retrofit process, refer to the Torque Tables at the back of this manual for specific torque values.

If you have any questions concerning the Retrofit Kit and / or the Retrofit process, contact Cutler-Hammer at 1-800-937-5487.

Work Sequence

Figure 1 illustrates the general work sequence for all DS Breaker Retrofit Kits.

The available Retrofit Kits are listed across the top of the figure. Under each kit, the components supplied with each kit, as well as the order in which they are to be installed (the work sequence), are listed. Note that the work sequence figure is cumulative from left to right. In other words, if a 610 Retrofit Kit was ordered, the Retrofit process would include the procedures listed under the 510, 510Z, and 610 columns and would be performed in the order in which they are numbered. For example, if a 610 Kit was ordered, the Retrofitter would (1) prepare the Breaker for the Retrofit, (2) install the Wire Guide, (3) install the ATR, (6) install the Mounting Frame, and so on.

Before beginning the Retrofit process, review the "Pick List" included with your Retrofit Kit (see Sample Pick List, Figure 2). The Pick List defines exactly which components (Style Numbers) are included with your kit and, therefore, which instructions to follow or skip. Lay out and become familiar with the components and hardware included with each Style Number on the Pick List.

Figure 1 Work Sequence

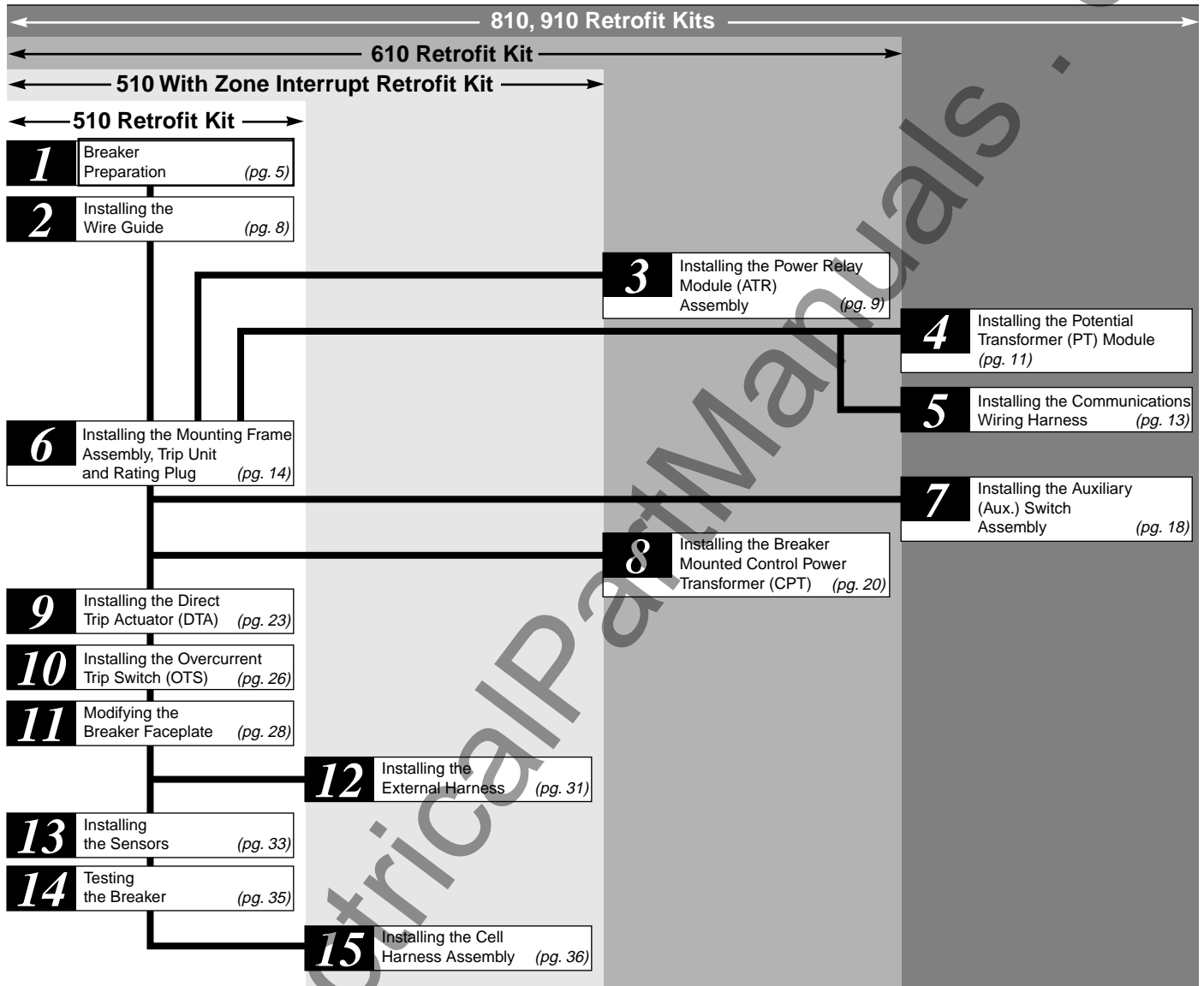

Tools and Equipment Required

Angle Drill
 Small Blade Screwdriver
 Medium Blade Screwdriver
 7/16" Wrench and / or Socket & Ratchet
 3/8" Wrench and / or Socket & Ratchet
 Diagonals (Wire Cutters)

Hacksaw (with Metal Cutting Blade)
 Rivet Gun
 Electric or Pneumatic Drill
 Primary Disconnect Removal Tool
 Center Punch
 #4 - 40 (0.112 - 40) Tap
 High Speed Drill Bits - .250" to .312", 0.089"
 Feeler Gauges

Figure 2 Sample Pick List

Another Quality Retrofit Kit From Cutler-Hammer Products A Division Of Eaton / Cutler-Hammer		
West DS (L) - 416 MOD MTG, RMS 810, Fully Wired, Full Kit, LSIG 60 HZ, 1600 AMP Plug, 1600 AMP Primary, Three 1600 AMP Sensors		
CAT Number: DRC866CC3C-TNNN		
<u>Style Number</u>	<u>Description</u>	<u>Qty.</u>
AD33-855	Application Data	1
IL33-DRC-1	IL DS Kits	1
7829CO8G06	Trip RMS S86LSIG	1
4A35629G01	DTA DS Digitrip	1
8154A01G02	Aux CT / MTG DS Gnd.	1
8154A05G01	Cover Assy DS	1
8154A07G01	OTS Parts DS	1
6502C71G03	Cell Harn Comm.	1
6502C82G01	PT Module	1
8154A02G01	ATR Assy DS	1
8154A03G01	Comm Assy DS	1
8154A06G01	Aux Parts DS	1
3D86734G23	Plug DS RP6D16A160	1
8153A04G01	Ext Harn DS 510 NZ	1
8154A09G01	Ext Harn DS 601 / Comm.	1
151D995G16	Sensor 1600 SR	3
This Retrofit Kit Checked for Quality By		
		Date: <u>11/20/96</u>

1

Breaker Preparation

1.0 General Breaker Preparation

Before attempting to remove the Breaker, or perform any Retrofit operation, be sure to read and understand the Safety Precautions Section of this manual. In addition, be sure to read and understand the Retrofit Application Data supplied with the Digitrip RMS Retrofit Kit.

Follow the DS Instruction Manual originally supplied with the Breaker to perform the following procedures.

Note: It is the responsibility of the Retrofitter to insure that the Breaker and all original components are in good condition. Visually inspect all Breaker components for signs of damage or wear. If any signs of damage or wear are detected for components not included in the Retrofit Kit, secure the necessary replacement parts before beginning the Retrofit process.

The force necessary to trip the Breaker **MUST NOT EXCEED 3 pounds.**

STEP 1:

Trip the Breaker and remove it from the Cell. Move the Breaker to a clean, well-lit work bench.

STEP 2:

Remove the nut, bolt, and washers that secure the Charging Handle to the Breaker. Remove the Charging Handle. Set the Charging Handle and mounting hardware aside for future use.

STEP 3:

Remove the four screws that secure the Faceplate to the Breaker. Remove the Faceplate. Set the Faceplate and screws aside for future use.

Note: For Models DS 632 and DS 840, there are six screws that secure the Faceplate to the Breaker.

2.0 Removing the Trip Unit

Note: Before beginning this procedure, please read the following information carefully.

Older DS Breakers were equipped with an **Amptector Trip Unit**, while newer models were equipped with a **Digitrip RMS Trip Unit**. If the Breaker was equipped with an Amptector Trip Unit, proceed with the steps detailed in Section 2.1. If the Breaker was equipped with an RMS Trip Unit, proceed to Section 2.2 for detailed instructions.

Note: If the Breaker was equipped with a Digitrip RMS Trip Unit and a new unit has been supplied with your Retrofit Kit (reference the Pick List provided with the Retrofit Kit), please return the original Digitrip RMS Trip Unit Assembly and its mounting assembly to the distributor from whom the kit was purchased.

2.1 Removing the Original Amptector Trip Unit Assembly

STEP 1:

Tag and label the existing wires connected to terminals "A" through "ON", located on the Amptector Trip Unit's Terminal Block. Disconnect the wires.

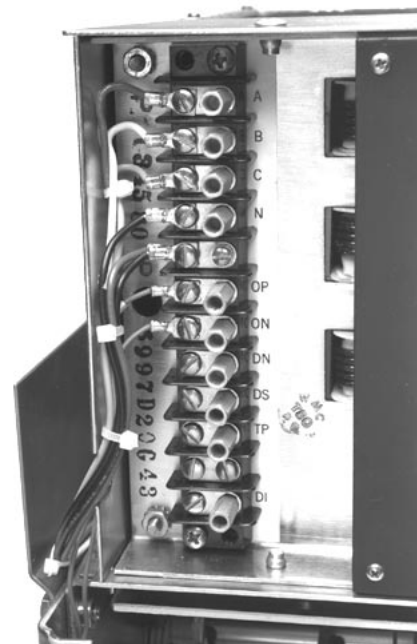

STEP 2:

Remove and scrap the rubber grommet from around the Sensor Wiring Harness.

STEP 3:

Cut the ring terminals from the ends of the wires that were connected to the "OP" and "ON" terminals. Remove and scrap these two wires from the wiring harness leading to the Direct Trip Actuator (DTA).

STEP 4:

Set aside the remaining Sensor Wiring Harness. It will be connected to the new Digitrip Mounting Frame assembly later in the Retrofit process.

STEP 5:

Remove and scrap the two screws that secure the Amptector Trip Unit to the Breaker Platform.

STEP 6:

Remove the Amptector Trip Unit from the Breaker Platform and scrap the unit.

2.2 Removing the Original Digitrip RMS Trip Unit Assembly

STEP 1:

Tag and label the existing wires connected to terminals "A" through "ON", located on the Digitrip RMS Trip Unit Assembly. Disconnect the wires.

STEP 2:

Remove and scrap the hardware that secures the RMS Trip Unit Assembly to the Breaker Platform.

STEP 3:

Remove the RMS Trip Unit Assembly from the Breaker Platform. Package it for shipment to the distributor from whom the kit was purchased.

3.0 Removing the Wire Guide

If the Breaker was originally equipped with a U-shaped metal Wire Guide, located behind the Amptector or RMS Trip Unit, it must be removed and replaced with the new Wire Guide supplied with your Retrofit Kit. The new Wire Guide will permit the Wiring Harness to be routed behind the new RMS Trip Unit / Mounting Frame Assembly.

If the Breaker was not equipped with a Wire Guide, Proceed to 4.0 - Removing the Existing Overcurrent Trip Switch (OTS).

Note: This section only provides instructions for removing the existing Wire Guide. Instructions for installing the new Wire Guide are covered later in the Retrofit process.

STEP 1:

Remove and scrap the two screws which mount the original Wire Guide to the Breaker platform.

Note: The screw securing the right side of the original Wire Guide may be located under the wiring harness leading to the Auxiliary Switches. If necessary for access, carefully cut the wire ties that hold the wiring harness in place and gently push the harness aside to obtain access to the screw.

STEP 2:

Remove and scrap the existing Wire Guide and mounting hardware.



4.0 Removing the Existing Overcurrent Trip Switch (OTS)

Note: Before beginning this procedure, please read the following information carefully.

If your Retrofit Kit includes a new Direct Trip Actuator (DTA) (Style Number 4A35629), **and** the Breaker was originally equipped with an Overcurrent Trip Switch (OTS), the OTS must be removed to provide access to the DTA. If a new DTA **has not been included** in your Retrofit kit, or if your Breaker was not equipped with an OTS, the steps in this section should be skipped.

This section only provides instructions **for removing the existing OTS**. The instructions for re-installing and adjusting the OTS are covered later in the Retrofit process.

STEP 1:

From the bottom of the Breaker, remove and scrap the two (2) hex bolts which secure the OTS to the Breaker Frame.

STEP 2:

Tag and remove the wires from the OTS terminals.

STEP 3:

Remove the OTS from the Breaker.

The Breaker is now prepared for the installation of the new components supplied with the Digitrip Retrofit Kit. Due to the number of models within the Westinghouse DS family of Breakers and the options available, the installation of each major component will be treated separately. Refer to the following pages for specific instructions for the installation of each new and / or replacement component.



2 Installing the Wire Guide

Pick List Style Number 8154A01

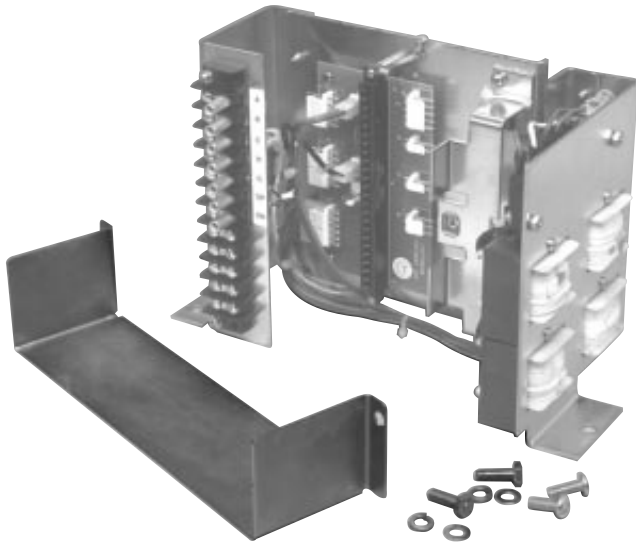

Digitrip Retrofit Components & Hardware Provided:

Description	Qty.
Style Number 8154A01	
Mounting Frame Assembly	1
(See Note Below)	
Wire Guide	1
.250-20 × .750 Lng. Bolt - Hex	2
.250 Flat Washer - Stl.	2
.250 Lock Washer - Stl.	2



Note: If your DS Breaker was not equipped with a Wire Guide, skip the Installing the Wire Guide procedure. Scrap the new Wire Guide (from Style # 8154A01 on the Pick List) and hardware supplied with the Retrofit Kit.

STEP 1:
Position the new Wire Guide with the sides pointing towards the front of the Breaker.

STEP 2:
Align the holes in the new Wire Guide with the existing holes in the Breaker platform. Carefully tuck the existing wiring along the sides and back of the Wire Guide. Make certain no wires are pinched.

STEP 3:
Using the hex bolts, lock washers, and flat washers provided, mount the new Wire Guide to the Breaker platform.

Note: There are four (4) different Mounting Frame Assemblies available for the DS Series Breakers. The correct Mounting Frame Assembly MUST be used. Be sure you have the correct Mounting Frame Assembly for the DS Breaker being retrofitted before continuing the Retrofit Procedure. Refer to the following list for specific applications.

Breaker Model	Mounting Frame Assembly
DS Without Ground (all except DS 632)	6506C63G01
DS With Ground (all except DS 632)	6506C63G02
DS 632 Without Ground	6506C63G11
DS 632 With Ground	6506C63G12



3 Installing the Power Relay Module (ATR) Assembly

Pick List Style Number 8154A02

Note: Complete this section **BEFORE** proceeding to Section 6.



Digitrip Retrofit Components & Hardware Provided:

<u>Description</u>	<u>Qty.</u>
Style Number 8154A02	
ATR Assembly	1
.138-32 x .500 Lng. Screw - T.C.	2
.138 X-Wide Washer - Stl.	2
.138 Flat Washer - Stl.	2
.138 Lock Washer - Stl.	2
Nylon Wire Tie	4

STEP 1:
Working from the rear of the Mounting Frame Assembly (8154A01), place an X-wide flat washer, provided with the Power Relay Module (ATR) Assembly Kit, over both of the pre-drilled mounting holes for the ATR Assembly. These X-wide washers act as spacers between the ATR Assembly and Mounting Frame Assembly.

STEP 2:
Position the ATR Assembly over the pre-drilled holes.

STEP 3:
Using the .138" screws, lock washers, and flat washers provided, secure the ATR Assembly to the Mounting Frame Assembly.

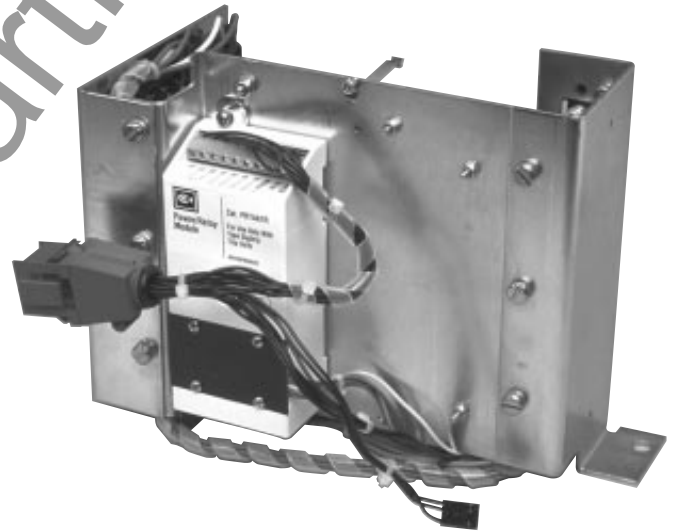

STEP 4:
Leave the ATR Plug loose at this time. It will be connected to the External Harness later in the Retrofit process.

STEP 5:
Route the remaining wires in the ATR Wiring Harness towards the bottom of the Mounting Frame Assembly.

STEP 6:

Route the 5 wire plug under the bottom of the Mounting Frame Assembly to the Circuit Board attached to the inside of the Mounting Frame Assembly. Attach the plug to the "P8" receptacle.

CAUTION: The plastic latches on the receptacles on the Circuit Board are delicate and can be easily broken. Care should be taken at all times when making connections to the Circuit Board.

STEP 7:

Following the same path, route the multi-colored ATR Wiring Harness to the Circuit Board. Attach the plug to the "P9" receptacle.

STEP 8:

Using the wire ties provided, dress all ATR wires to keep them away from sharp edges.

Note: For certain installations - The male plug with three (3) wires is connected to the Communications Wiring Harness. See Section 5.

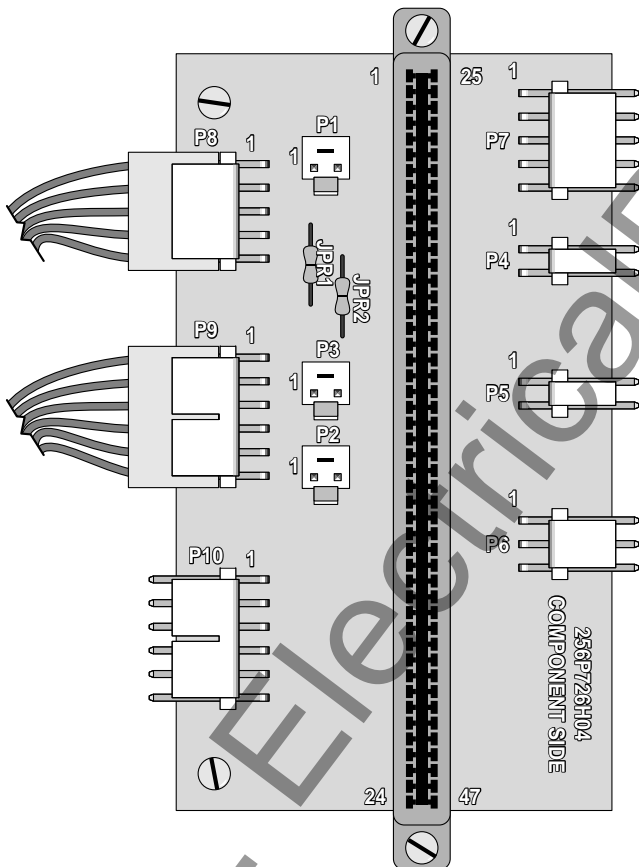

4 Installing the Potential Transformer (PT) Module

Pick List Style Numbers 6502C82 and 8154A03

Note: Complete this section **BEFORE** proceeding to Section 6.

Note: Extra hardware is included with the PT Module Assembly. Discard any hardware that is not needed for installation.

STEP 1:
Remove the Mounting Bracket, Connector Bracket, and Name Plate from the Potential Transformer (PT) Module Assembly.

STEP 2:
Using the original hardware, reconnect the Connector Bracket to the side of the PT Module as shown.



Digitrip Retrofit Components & Hardware Provided:

Description	Qty.
Style Number 6502C82	
PT Module	1
.138 Flat Washer - Stl.	2
.138 Lock Washer - Stl.	2
Style Number 8154A03	
.138-32 x .375 Lng. Screw - T.C.	2
.138 X-Wide Washer - Stl.	2

STEP 3:

Working from the left side of the Mounting Frame Assembly (8154A01), place an X-wide flat washer, provided with the PT Module Kit, over both the pre-drilled mounting holes for the PT Module. These X-wide washers act as spacers between the PT Module and Mounting Frame Assembly.

STEP 4:

Position the PT Module over the pre-drilled holes.

STEP 5:

Using the .138" screws, lock washers, and flat washers provided, secure the PT Module to the Mounting Frame Assembly.

Note: The PT Module Plug will be connected to the Communications Wiring Harness (Style Number 8154A03) when installed. See Section 5.

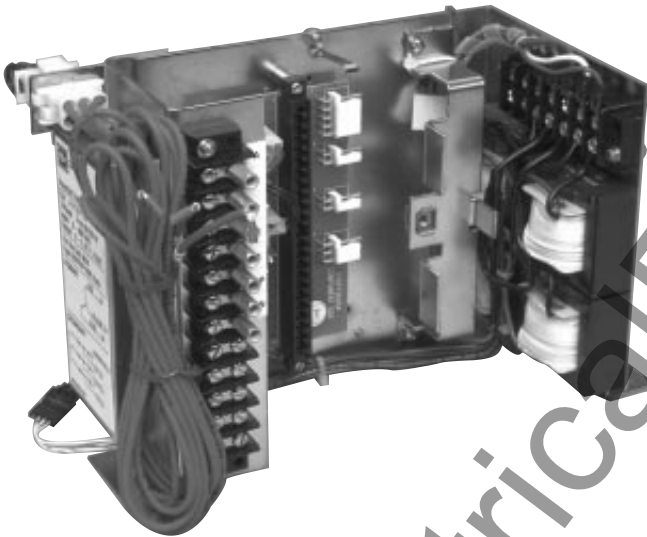

5 Installing the Communications Wiring Harness

Pick List Style Number 8154A03

Note: Complete this section **BEFORE** proceeding to Section 6.



Digitrip Retrofit Components & Hardware Provided:

Description	Qty.
Style Number 8154A03	
Communications Wiring Harness	1
.138-32 × .375 Lng. Screw - T.C.	2
.138 X-Wide Washer - Stl.	2
Nylon Wire Tie	6

STEP 1:
Working from the back of the Mounting Frame Assembly (8154A01), connect the male plug with four (4) wires to the female plug from the Potential Transfer Module (PT).

STEP 2:
Connect the female plug with three (3) wires to the male plug on the Power Relay Module (ATR) Wiring Harness.



Note: The two (2) wires with the ring terminals will be connected to the Auxiliary (Aux.) Switch Assembly (Style Number 8154A06) when installed. See the instructions provided in Section 7 for detailed information.

STEP 3:
Using the wire ties provided, dress all wires to keep them in place and away from any sharp edges. Leave enough of the harness free to connect the Trip Unit later in the Retrofit process. The front of the 9 pin connector should extend approximately 1" beyond the left front of the Mounting Frame as shown.

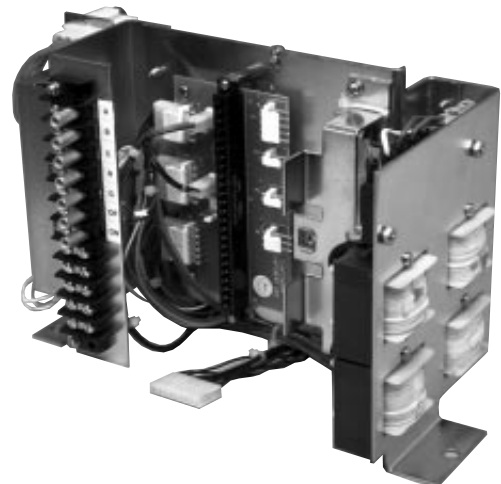



6 Installing the Mounting Frame Assembly, Trip Unit, and Rating Plug

Pick List Style Numbers 8154A01, 8154A04, 8154A06, 7829C__ , and 3D86734

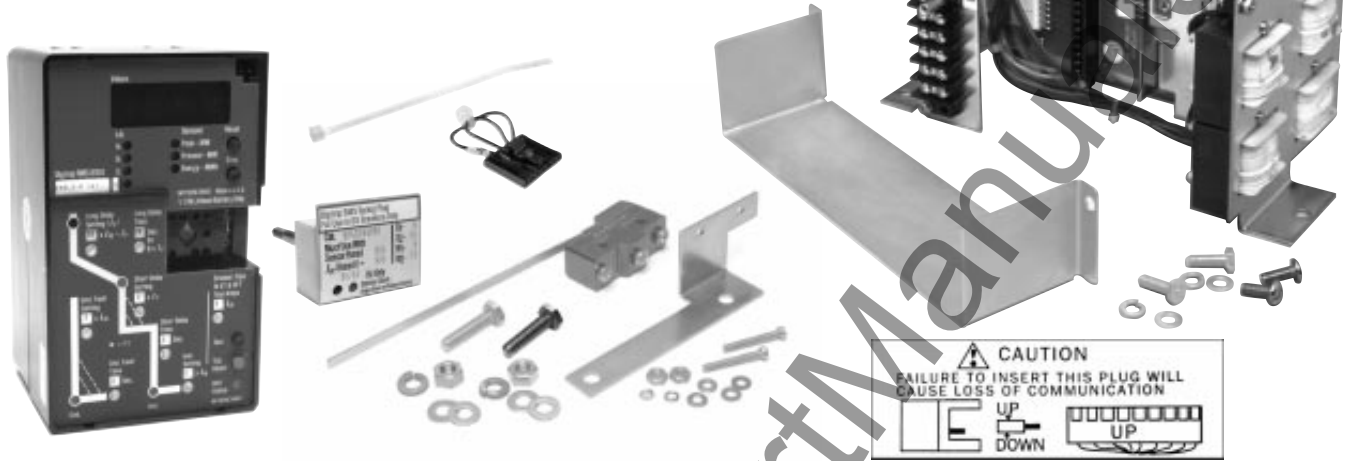

Digitrip Retrofit Components & Hardware Provided:

Description	Qty.	Description	Qty.
Style Number 8154A01		Style Number 8154A04	
Mounting Frame	1	Zone Interlock Shorting Plug	1
(See Note Below)		Wire Tie	1
Negative Power Shorting Plug	1	Style Number 8154A06	
.250-20 × .500 Lng. Screw - Pan	2	Label	1
.250 Flat Washer - Stl.	2	.250 × 1.00 Lng. Hex Bolt	1
.250 Lock Washer - Stl.	2	.190-32 × 1.00 Lng. Screw - Fil.	3
Style Number 7829C__ (see Pick List)		.190 Flat Washers - Stl.	6
Trip Unit	1	.190 Lock Washers - Stl.	3
Style Number 3D86734		.190-32 Nut Hex.- Stl.	3
Rating Plug	1		

Note: There are four (4) different Mounting Frame Assemblies available for the DS Series Breakers. The correct Mounting Frame Assembly MUST be used. Be sure you have the correct Mounting Frame Assembly for the DS Breaker being retrofitted before continuing the Retrofit Procedure. Refer to the following list for specific applications.

Breaker Model	Mounting Frame Assembly
DS Without Ground (all except DS 632)	6506C63G01
DS With Ground (all except DS 632)	6506C63G02
DS 632 Without Ground	6506C63G11
DS 632 With Ground	6506C63G12

Note: Before installing the Mounting Frame Assembly (8154A01) in the Breaker, all optional Retrofit components that mount to the frame should be installed. These would include Pick List Numbers 6502C82, 8154A02, and 8154A03. Refer to Sections 3, 4, and 5 for each optional component for specific procedures and details.

Note: If the DS Breaker being retrofitted is equipped with a BF Relay, refer to the Addendum at the rear of this manual before continuing with this procedure.

STEP 1:

Align the holes on the bottom of the left- and right-hand Mounting Frame Sides with the holes in the Breaker Shelf. (These holes were used to mount the original Amptector or Digitrip Box).

STEP 2:

Using the screws, lock washers, and flat washers provided, secure the Mounting Frame Assembly to the Breaker Shelf.

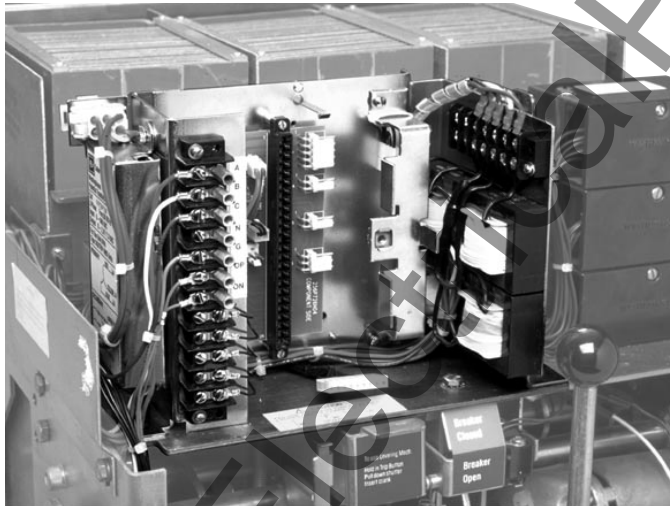

Note: If an Auxiliary Switch Assembly has been included with the Retrofit kit (see Pick List), use the .250 - 20 x 1.00 bolt supplied with the kit to secure the right side of the Mounting Frame. Discard one of the bolts provided with the mounting frame.

STEP 3:

Connect the tagged wires (A, B, C, N, and G) of the Sensor Wiring Harness to the proper terminals of the terminal block located on the left side of the Mounting Frame.

STEP 4:

For 510 Basic Kits Only. Plug the Zone Interlock Shorting Plug (8154A04) into the "P8" connector on the circuit board.

CAUTION: The plastic latches on the receptacles on the Circuit Board are delicate and can be easily broken. Care should be taken at all times when making connections to the Circuit Board.

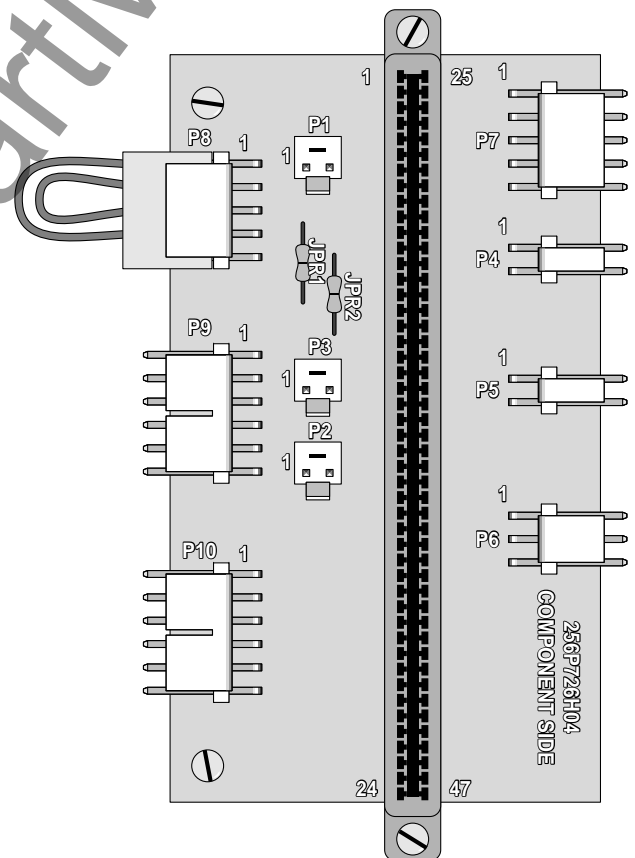

For All Other Kits. Wire tie the Zone Interlock Shorting Plug to the wires connected to the "P8" terminal. Do not plug it in at this time, it will be used for testing purposes only.

For 810, & 910 Kits Only

Only for Certain Applications - If the Breaker being Retrofitted is to be used in an application where negative power readings must be defeated, the Negative Power Shorting Plug must be installed. If this capability is not required, skip ahead to Step 6.

STEP 5:

For 810, & 910 Kits Only. To defeat negative power readings, cut the wire tie attaching the Negative Power Shorting Plug to the Mounting Frame Assembly. Connect the Negative Power Shorting Plug to the "P5" connector on the Circuit Board.

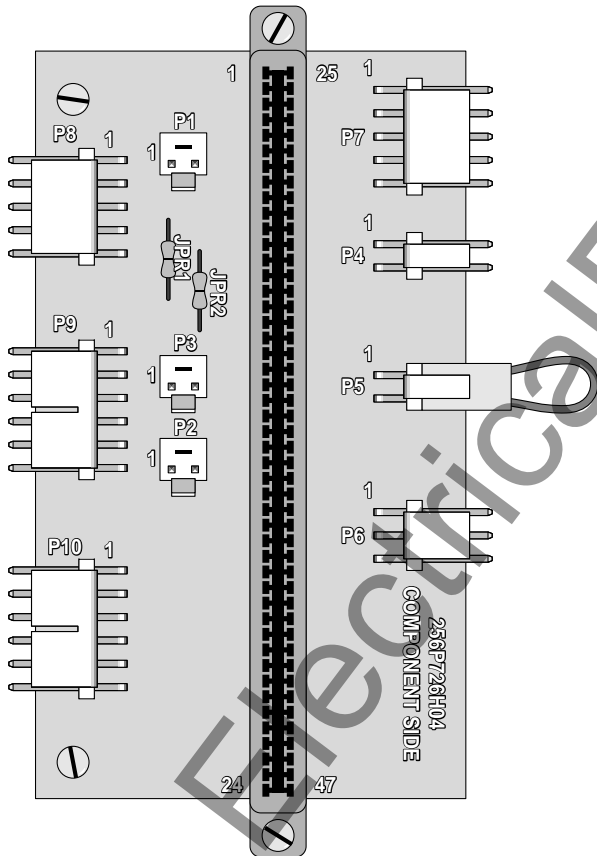

CAUTION: The plastic latches on the receptacles on the Circuit Board are delicate and can be easily broken. Care should be taken at all times when making connections to the Circuit Board.

STEP 6:

For 810 & 910 Kits Only. Install the Warning Label provided with the Retrofit Kit on the Breaker Shelf as shown.



STEP 7:

For 810 & 910 Kits Only. Position the Trip Unit near the front of the Circuit Board. Insert the male Communications Harness Connector into the female receptacle in the back of the Trip Unit. Note that the metal pins on the Communications Harness Connector must face upward (see the Warning Label installed in Step 6 for illustration).

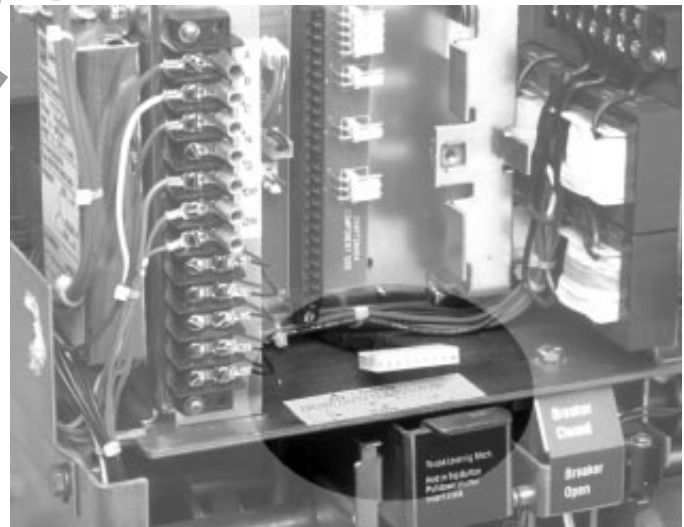

CAUTION: If the Communications Harness Connector is inserted upside down (metal pins facing downward), communications problems will occur.

STEP 8:

Align the Digitrip RMS Trip Unit edge card with the receptacle on the Circuit Board attached to the Mounting Frame Assembly. Assure that the spring clip attached to the Mounting Frame Assembly is above the top of the Trip Unit. Plug the Trip Unit into the Mounting Frame Assembly.

CAUTION: Do not apply undue force to the Trip Unit. If it does not plug easily into the Mounting Frame Assembly, make sure the edge card is properly aligned with the receptacle. Applying undue force can damage the Trip Unit and / or the Circuit Board.



Note: The Trip Unit Edge Card Connector must seat properly in the Trip Unit Box before the Rating Plug is installed.

STEP 9:

Open the snap down cover on the Rating Plug and push the plug into the Digitrip RMS Trip Unit. Tighten the screw into the Trip Unit Box. Close the cover.



For 810, & 910 Kits Only, All Remaining Steps Apply.

STEP 10:

Route the three (3) PT Wires through the wire channel, located on the top left of the Breaker, back towards the Phase 1, 2, and 3 Breaker Top Studs.

STEP 11:

Locate a bolt on each Breaker Top Stud to which the PT Wires can be attached. If a bolt can not be located, use an angle drill to drill a .219" diameter hole in each Breaker Top Stud (see photo).

**STEP 12:**

Each PT Wire is marked with a number corresponding to the Phase to which it is to be attached. Cut each PT Wire to an appropriate length. Strip off .250" of insulation, and attach a .190" ring terminal to each wire.

STEP 13:

Using either the original hardware or the hardware provided with the Retrofit Kit, attach each PT Wire to the corresponding Breaker Top Stud.



7

Installing the Auxiliary (Aux.) Switch Assembly

Pick List Style Number 8154A06

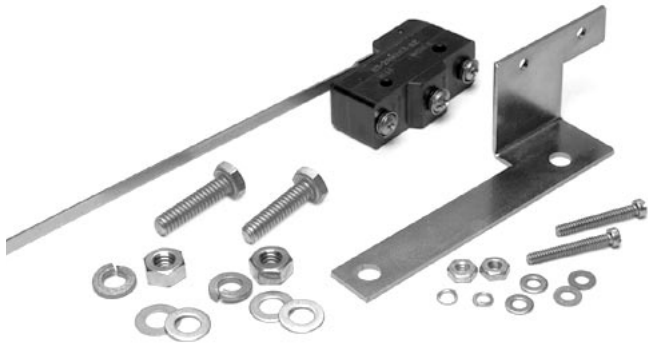

Digitrip Retrofit Components & Hardware Provided:

Description

Qty.

Style Number 8154A06

Microswitch	1
Mounting Bracket	1
.138-32 × 1.00 Lng. Screw - Fil.	2
.138 Flat Washer - Stl.	4
.138 Lock Washer - Stl.	2
.138-32 Nut Hex. Stl.	2
.250-20 × 1.00 Lng. Hex. Bolt	2
.250 Flat Washer - Stl.	4
.250 Lock Washer - Stl.	4
.250-20 Nut Hex. Stl.	2

STEP 1:

Place a .138" flat washer on each of the .138-32 × 1.00 screws provided with the kit.

STEP 2:

Align the holes in the Microswitch with the holes in the Aux. Switch Mounting Bracket.

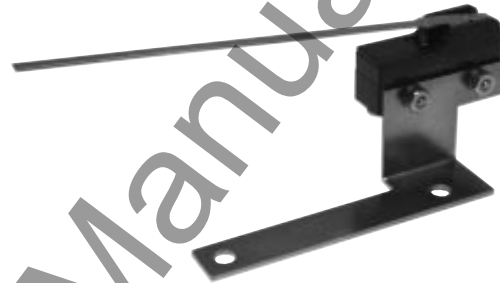

STEP 3:

Insert the screws through the Microswitch and the holes in the mounting bracket. Secure with the .138" flat washers, lock washers, and hex nuts provided.

STEP 4:

Using the new .250 bolts, lock washers, flat washers, and nuts provided with the Retrofit kit, mount the Aux. Switch Assembly to the bottom of the Breaker Shelf as shown.

Note: The Microswitch arm should ride on the Cam of the Breaker Pole Shaft.

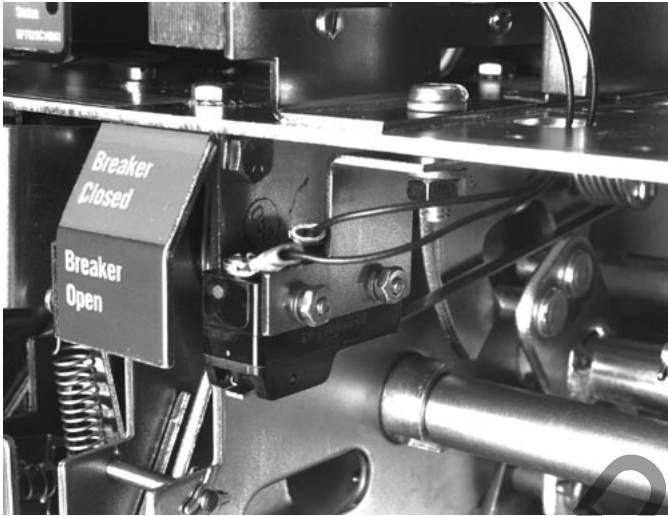
**STEP 5:**

Once proper alignment has been assured, tighten the mounting hardware.

STEP 6:

Route the wires with the ring terminals from the Communications Wiring Harness (Style Number 8154A03) to the Aux. Switch Assembly.

STEP 7:

Connect one (1) wire to the "normally open" terminal and the other to the "common" terminal.

STEP 8:

Using the wire ties provided, dress the wires to keep them away from any moving parts or sharp edges within the Breaker.

8 Installing the Breaker Mounted Control Power Transformer (CPT)

Pick List Style Numbers 8259A91



Digitrip Retrofit Components & Hardware Provided:

Description	Qty.
Style Number 8259A91	
Transformer	1
HV Fused Wires	2
.190-32 x .750 Lng. Fil. - Stl.	6
.190 Flat Washer - Stl.	12
.190 Lock Washer - Stl.	6
.190-32 Hex Nut - Stl.	6
.190 Ring Terminal (Uninsulated)	2
.138 Ring Terminal (Uninsulated)	4
Labels (480, 240, and 208 Volt)	3

STEP 1:

Working from the bottom of the Breaker, drill four (4) .219" holes in the Breaker Bottom Plate.

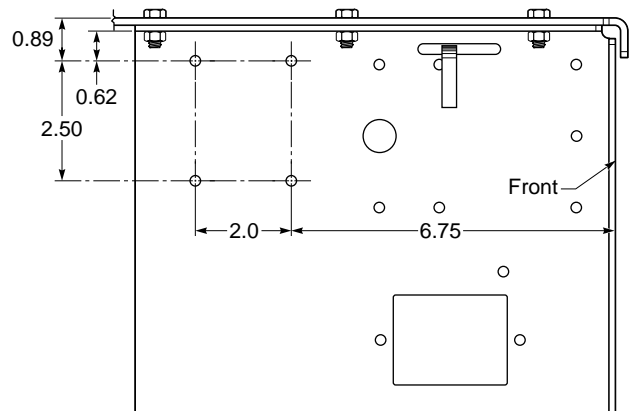



STEP 2:

Position the Control Power Transformer (CPT) over the previously drilled holes, making sure that the X1 and X2 terminals face the front of the Breaker. Using the .190" bolts, flat washers, lock washers, and nuts provided, mount the CPT to the Breaker Bottom Plate.

STEP 3:

Position the HV Fused Wires (HV Wires) in the Breaker so the fuses are located in a clear, accessible area. The **Load Side** of the Fused Wires go to the CPT Transformer and the **Line Side** of the Fused Wires go to the Line side of the Breaker.

Note: The HV wires are longer than necessary and are to be cut during the following steps. Before cutting the wires, be sure that sufficient length is left so that the fuses are accessible and that the connections can be made at the CPT and Breaker Studs.

STEP 4:

Cut the Load Side of each HV Wire to length for attachment to the appropriate CPT terminal. Strip each wire .250" and attach a .138" ring terminal to each wire.

STEP 5:

Mount the HV Wires to the proper CPT terminals to achieve the required voltage. (See following table.)

Voltage Required	CPT Terminals Used
480 Volt Circuit	H1 & H4
240 Volt Circuit	H1 & H3
208 Volt Circuit	H1 & H2

STEP 6:

Route the HV Wires through the opening in the back of the Breaker Frame and up towards the Breaker Studs.



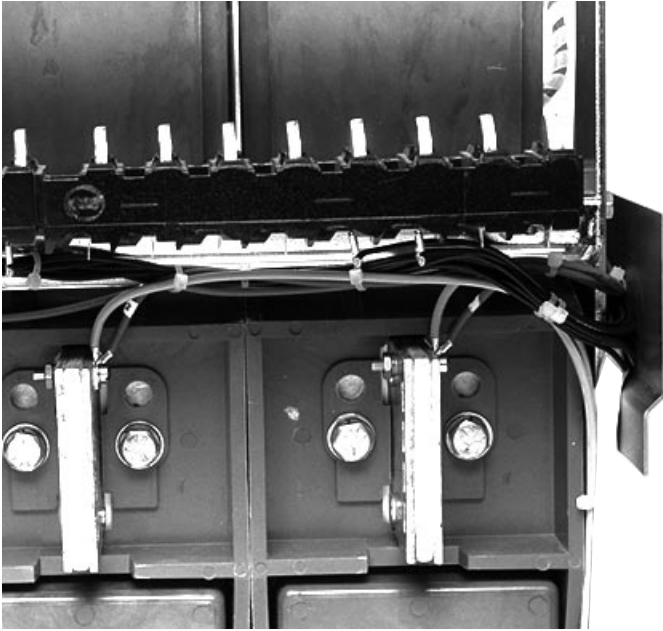

*Note: The power convention of DS Breakers is normally Top to Bottom, meaning the top studs are on the **LINE side** of the breaker and the bottom studs are on the **LOAD side**.*

*The **HV wires** for the CPT must be attached to the **LINE side** of the breaker (as shown in the photo). If it is determined that the power flow is opposite the normal convention, the HV wires for the CPT must be attached to the bottom studs (NOT as shown).*

STEP 7:

Locate a bolt on the Phase 1 and 2 Breaker Studs to which the HV Wires can be attached. If a bolt can not be located, use an angle drill to drill a .219" diameter hole in each Breaker Stud (see photo).

STEP 8:

Cut each HV Wire to an appropriate length. Strip each wire .250" and attach a .190" ring terminal to each wire.

STEP 9:

Using either the original hardware or the hardware provided with the Retrofit Kit, attach the HV Wires to the Phase 1 and 2 corresponding Breaker Studs.

STEP 10:

Use the nylon wire ties provided to dress all wires and keep them away from any moving parts within the Breaker.

STEP 11:

Three (3) labels are included with the CPT, one (1) for 480 Volt, one (1) for 240 Volt, and one (1) for a 208 Volt system. Attach the appropriate label for the application to the Breaker Front Cover in a clearly visible position.

9 Installing the Direct Trip Actuator (DTA)

Pick List Style Numbers 4A35629 and 8154A07



WARNING

Use only the proper Digitrip RMS style DTA assembly provided with your Retrofit Kit. If any pre-existing or any other DTA assembly is being used, the Breaker may not trip correctly, which could lead to death, severe personal injury, and / or equipment damage.

Digitrip Retrofit Components & Hardware Provided:

Description	Qty.
Style Number 4A35629	
DTA Assembly.....	1
Style Number 8154A07	
.250-20 × .500 Lng. Bolt - Nylock	3
Trip Shaft Reset Spring.....	1

STEP 1:

Before installing the Direct Trip Actuator (DTA) assembly, test it **several times** by performing the following procedure.

- A. Reset the DTA assembly by pulling back on the DTA Reset Lever.
- B. Connect a 24 V DC power source to the DTA terminals (positive to positive and negative to negative). Energize the DTA and observe for proper “trip” action.
- C. If satisfied with the DTA trip action after several operations, proceed to Step 2.

a) DTA / Breaker Trip Finger (DTA Tripped)

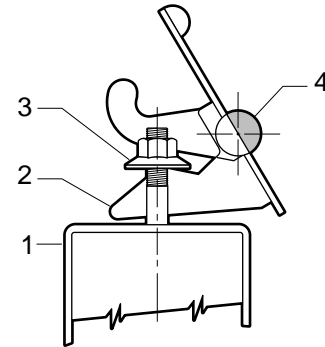

b) DTA Reset

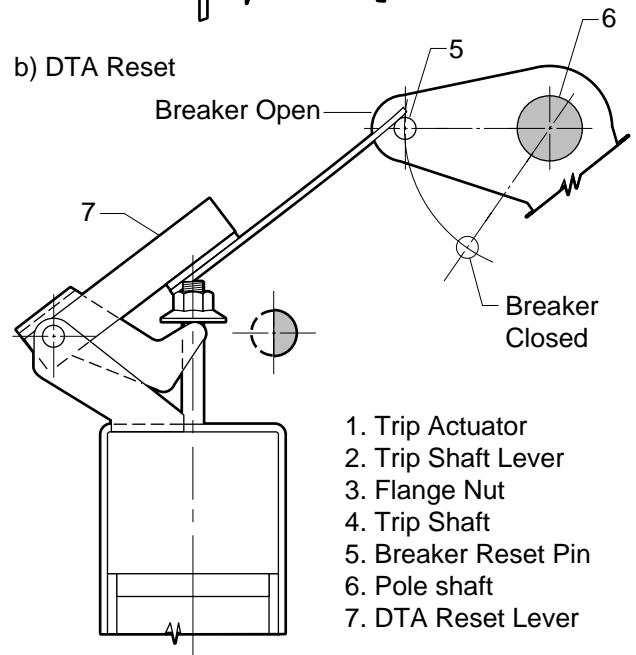

1. Trip Actuator
2. Trip Shaft Lever
3. Flange Nut
4. Trip Shaft
5. Breaker Reset Pin
6. Pole shaft
7. DTA Reset Lever

STEP 2:

Locate the Trip Shaft Reset Spring which connects the original DTA frame to the Breaker Trip Shaft. Note the position and connection points of the spring. Remove and scrap the Trip Shaft Reset Spring. A new one is provided in the Overcurrent Trip Switch (OTS) - (Style Number 8154A07).

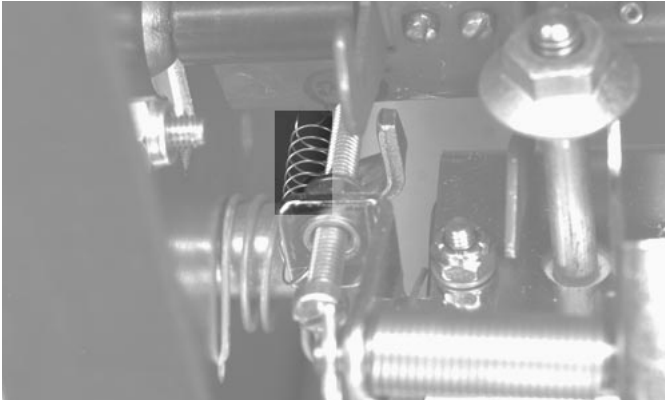
**STEP 3:**

Remove and scrap the three (3) hex bolts from the bottom of the Breaker which secure the existing DTA assembly to the Breaker frame.

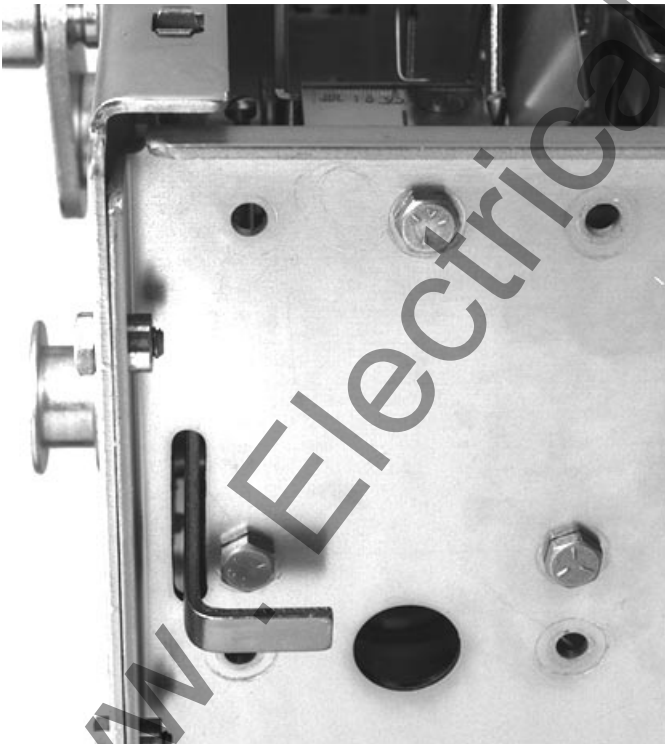

CAUTION: The Breaker must be in the open position before continuing with the DTA assembly installation.

STEP 4:

Remove the DTA assembly, complete with the "OP" and "ON" wires, from the Breaker.

*Note: If the breaker being retrofitted was equipped with an Overcurrent Trip Switch, proceed to the **Installing the Overcurrent Trip Switch (OTS)** procedure (Section 10) at this time. If the Breaker was not equipped with an OTS, continue with Step 5.*

STEP 5:

With the DTA in the reset position, place the DTA assembly in position in the Breaker. The DTA Flange Nut should be positioned over the Breaker Trip Finger. The spring finger of the DTA Reset Lever should be positioned above the Breaker Reset Pin.

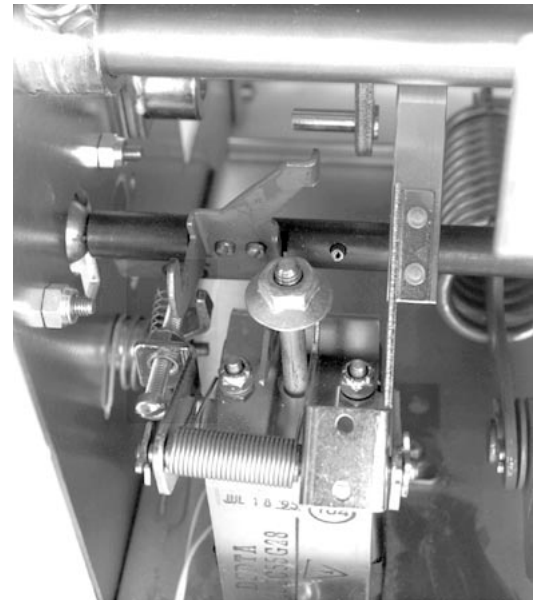
**STEP 6:**

Align the DTA assembly with the holes in the Breaker frame. Mount the DTA assembly to the Breaker frame using three (3) - .250-20 x .500 Nylock bolts provided with the kit.

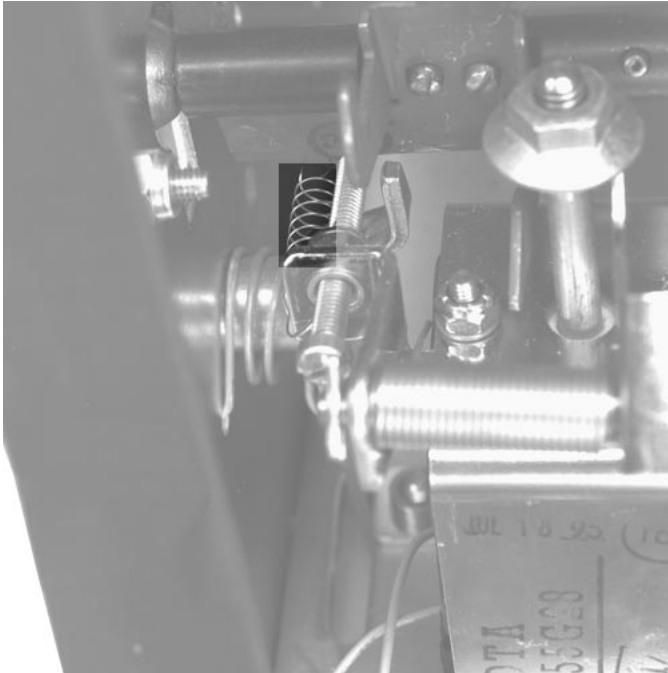
**STEP 7:**

Install new Trip Shaft Reset Spring.

STEP 8:

To provide the correct Breaker Trip Latch Overlap, the Trip Shaft Adjustment Screw on the DTA frame must be adjusted by performing the following procedures.

**WARNING**

To avoid severe personal injury and / or equipment damage, use suitable length tools and keep hands and loose clothing well away from any moving parts within the Breaker.

- A. Manually charge the Closing Spring and close the Breaker.
- B. Slowly rotate the Trip Shaft Adjustment Screw **clockwise** until the Breaker trips. This is called the “**no overlap position**”.
- C. **Slowly rotate** the Trip Shaft Adjustment Screw four (4) turns **counter-clockwise**. The Breaker Trip Shaft is now adjusted.

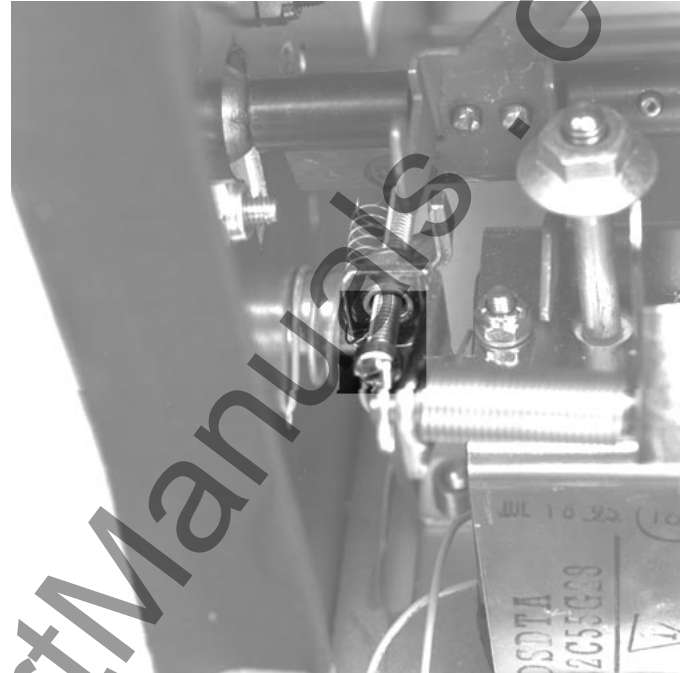
**STEP 9:**

Route the Direct Trip Actuator (DTA) Wiring Harness along the wiring harness located at the front left-hand corner of the Breaker to the Terminal Block on the Mounting Frame Assembly (8154A01).

STEP 10:

Connect the positive lead to the “OP” terminal. Connect the negative lead to the “ON” terminal.

Use the nylon wire ties provided to dress the DTA wires and keep them away from any moving parts within the Breaker.

**WARNING**

Failure to observe the proper polarity outlined in this step will prohibit the DTA from properly tripping the Breaker. This could lead to death, severe personal injury, and / or equipment damage.

*Note: If an Overcurrent Trip Switch is included in the Pick List, return to Section 10, Step 3 of the **Installing the Overcurrent Trip Switch (OTS)** procedure, at this time.*



10 Installing the Overcurrent Trip Switch (OTS)

Pick List Style Number 8154A07

STEP 1:

Using the pop rivets provided, mount the Overcurrent Trip Switch (OTS) Reset Lever to the Direct Trip Actuator (DTA) Reset Bracket as shown.



Digitrip Retrofit Components Provided:

Description

Qty.

Style Number (See Pick List)

OTS Trip Lever	1
Pop Rivet .125 × .063 - .125-Stl.	2
.250-20 × .500 Lng. Bolt - Nylock	2

STEP 2:

Return to Section 9, Step 5 of the **Installing the Direct Trip Actuator (DTA)** procedure. Complete the DTA Installation.

STEP 3:

Working from the bottom of the Breaker and using the two (2) Nylock bolts provided, mount the OTS to the breaker frame.



STEP 4:

Reconnect the OTS wiring to the original OTS terminals.

STEP 5:

The OTS Reset Lever must be adjusted. To adjust the lever, perform the following procedure.

CAUTION: To avoid personal injury and / or equipment damage, use suitable length tools and keep hands and loose clothing well away from any moving parts within the Breaker.

- A. Manually charge the closing spring and close the Breaker.
- B. Assure that the OTS Lever is in the **RESET** position.
- C. Using a feeler gauge, verify that there is a 0.030" gap between the OTS Reset Lever and the OTS Lever. If necessary, carefully bend the OTS Reset Lever to achieve the 0.030" gap.

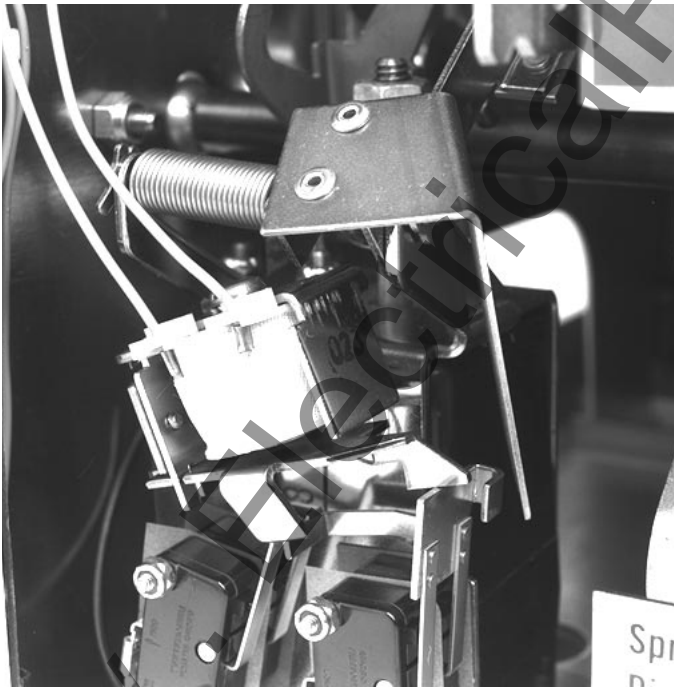

- D. To simulate an overcurrent condition, rotate the DTA Reset Bracket **clockwise**, as far as possible **without** tripping the Breaker. The OTS Reset Lever should push the OTS Lever into the latched position.
- E. If the OTS Lever does not latch, adjust the OTS Reset Lever as required.

Note: After the adjustment is complete, verify the correct OTS Reset Lever adjustment by repeating Procedure D at least twice.

- F. Once latched, the OTS Lever can be released by lifting the OTS Latch Lever.



11 Modifying the Breaker Faceplate

Pick List Style Number 8154A05



NOTICE
DIGITRIP RMS RETROFIT
 CIRCUIT ZONE INTERLOCKS, REMOTE SIGNALS, AND/OR INCOM COMMUNICATIONS MAY BE COMPROMISED UNLESS TRIP UNIT, BREAKER, AND SWITCHGEAR CELL ARE MATCHED.
 BREAKER ID NUMBER _____
 SWITCHGEAR CELL ID NUMBER _____
 TRIP UNIT CAT NO./INCOM ADDRESS _____
 PLUG BREAKER UMBILICAL CORD INTO SWITCHGEAR CELL PLUG TO CONNECT REMOTE SIGNALS AND COMMUNICATIONS.
PN 8187A68H01

Digitrip Retrofit Components & Hardware Provided:

<u>Description</u>	<u>Qty.</u>
Style Number 8154A05	
Cover Assembly	1
#4 - 40 Thumb Screw	4
#4 Flat Washer Stl.	4
#4 Flat Washer Fiber	4
Digitrip RMS ID Label	1
Amptector Test Kit Warning Label.	1
Spacers	2

STEP 1:

Temporarily install the Breaker Faceplate using the original hardware.

STEP 2:

Observe the position of the Trip Unit in relation to the Trip Unit Access Window in the Breaker Faceplate.

Note: Depending on the vintage of the Breaker, the size and location of the Trip Unit Access Window may vary. When the Breaker Faceplate is in place, the entire Trip Unit must be visible and accessible. If it is not, follow the procedures detailed in STEPS 3 and 4 as follows. If Trip Unit visibility and accessibility are adequate, proceed with STEP 5.

STEP 3:

If the Trip Unit is positioned too low in the Trip Unit Access Window for complete access and visibility, use the spacers provided to raise the Trip Unit Assembly. Remove the hardware securing the Trip Unit Assembly to the Breaker Shelf. Insert spacers as needed to raise the Trip Unit Assembly so that it aligns with the top of the Trip Unit Access Window. Tighten the Mounting Hardware.

STEP 4:

Again temporarily install the Breaker Faceplate. Insure that the entire Trip Unit, from the Aux. Power Module Plug in the top right corner to the Trip Unit Status Light on the bottom, is visible and accessible through the Trip Unit Access Window. If not, measure the amount that must be removed from the bottom of the Trip Unit Access Window.

Note: The minimum height of the Trip Unit Access Window should be approximately 5 9/16" (5.56").

STEP 5:

Remove the Breaker Faceplate. Using a hacksaw with a metal cutting blade, remove the metal separating the Trip Unit Access Window from the Terminals Access Window.

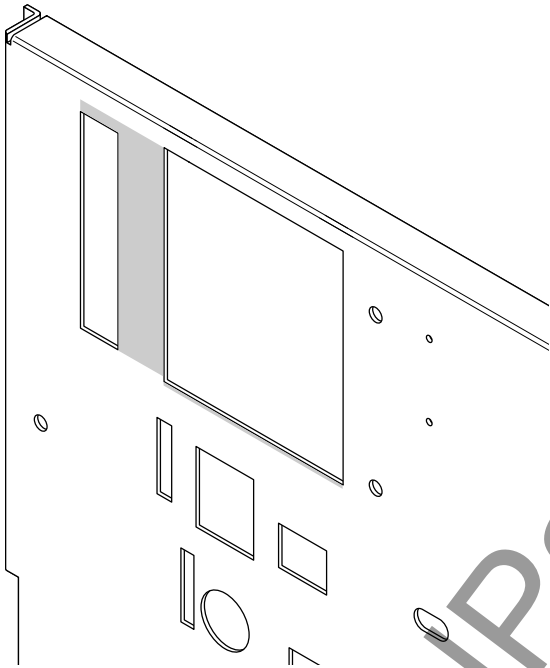

- A. If the height of the Trip Unit Access Window must be increased (see STEP 4), remove the additional metal from the bottom of the Trip Unit Access Window at this time.
- B. After the metal has been removed, file any rough edges smooth and touch up the exposed metal with paint.

STEP 6:

Temporarily install the Breaker Faceplate using the original hardware.

STEP 7:

Place the clear plastic Trip Unit Cover on the Breaker Faceplate, over the Digitrip RMS Trip Unit.

STEP 8:

Align the center of each of the three (3) slots in the Trip Unit Cover with the Trip Reset, Rating Plug Battery Check, and (on 610, 810 & 910 kits only) Step push buttons.

STEP 9:

Once aligned, use the Trip Unit Cover as a template and mark the four (4) corner Hole locations on the Breaker Faceplate.

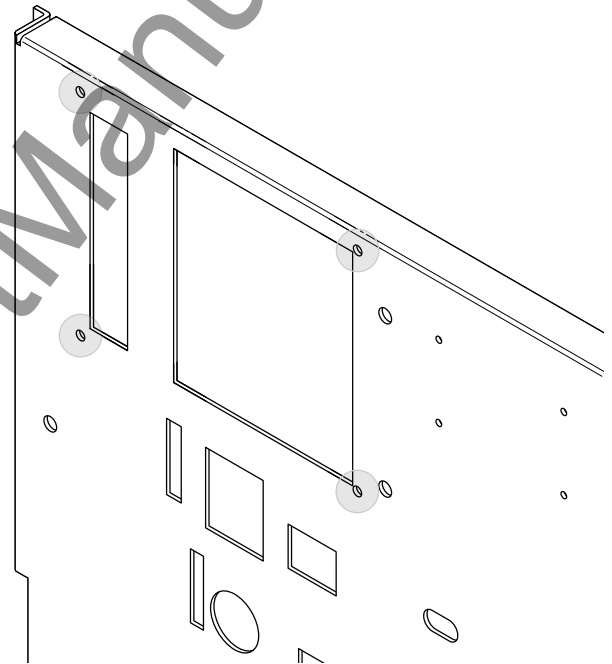
**STEP 10:**

Remove the Breaker Faceplate from the Breaker.

STEP 11:

Center punch the four (4) markings.

STEP 12:

Drill four (4) 0.089" holes (size 43 drill) at the center punched locations on the Breaker Faceplate.

STEP 13:

Tap each hole using a #4 - 40 (0.112 - 40) tap.

Note: If an External Harness (Style #8145A09) is not included on the Pick List, skip the procedures outlined in Step 14.

STEP 14:

Cut a notch to allow the External Harness to exit the Breaker by performing the following procedures.

- A. Using a hacksaw with a metal cutting blade, cut a 1" notch in the upper right-hand corner of the Breaker Faceplate.
- B. After the notch has been cut, file any rough edges smooth and touch up the exposed metal with paint.

Note: If a Breaker mounted CPT (Style #8259A91) is supplied with the Retrofit Kit, perform Steps 2 through 5 in Section 12, before reinstalling the Breaker Faceplate on the Breaker.

**STEP 15:**

Reinstall the Breaker Faceplate on the Breaker.

Step 16:

Align the four (4) corner holes of the Trip Unit Cover with the four (4) holes drilled in the Breaker Faceplate.

Note: Each thumb screw, with a steel flat washer installed, should be inserted into each of the four corner holes of the Trip Unit Cover and held in place by the fiber flat washers.

Step 17:

Using the thumb screws, steel flat washers, and fiber flat washers provided, secure the Trip Unit Cover to the Breaker Faceplate.

Step 18:

Affix the yellow Amptector Test Kit warning label on the Breaker Faceplate in a clearly visible location, near the Digitrip RMS terminal strip.

Step 19:

Affix the Digitrip RMS Retrofit ID label on the Breaker Faceplate in a clearly visible location.



12 Installing the External Harness

Pick List Style Number 8154A09

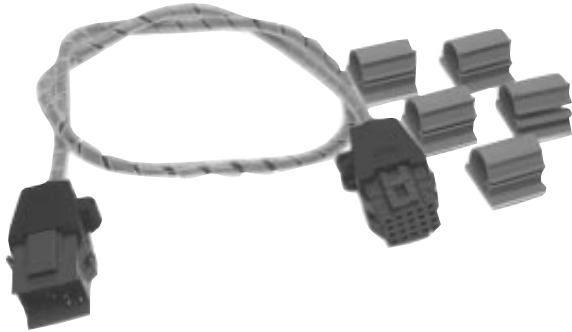

Digitrip Retrofit Components & Hardware Provided:

Description	Qty.
Style Number 8154A18	
External Harness	1
Wire Clamp (Stick-on Type)	5

STEP 1:

Insert the end of the External Harness into the AMP Plug on the Power Relay Module (ATR) Wiring Harness.



Note: If a Breaker Mounted CPT (Style #8259A91) is included in the Retrofit Kit, perform Steps 2, 3, 4, and 5. If a CPT was not supplied with your Retrofit Kit proceed to Step 6.

STEP 2:

Route the two (2) individual wires from the External Harness down through the Breaker to the CPT. Assure that the wires are clear of any moving parts within the Breaker.

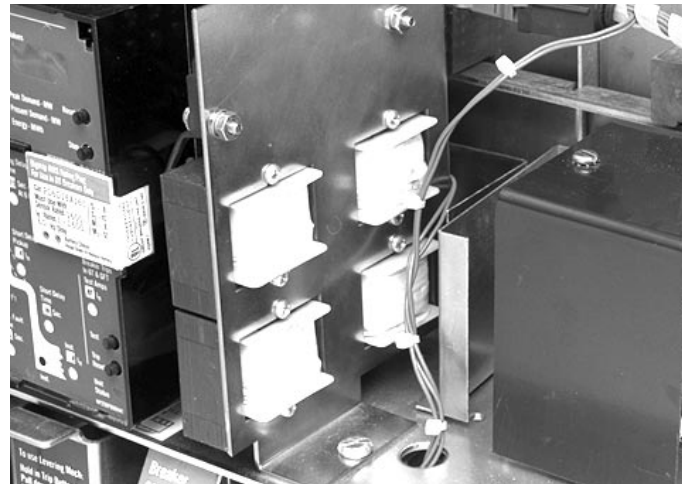

www.ElectricalParts.com

STEP 3:

Cut the wires to length. Strip .250" of insulation and attach a .138" ring terminal to each wire.

STEP 4:

Connect the wires to the X1 and X2 terminals of the CPT.

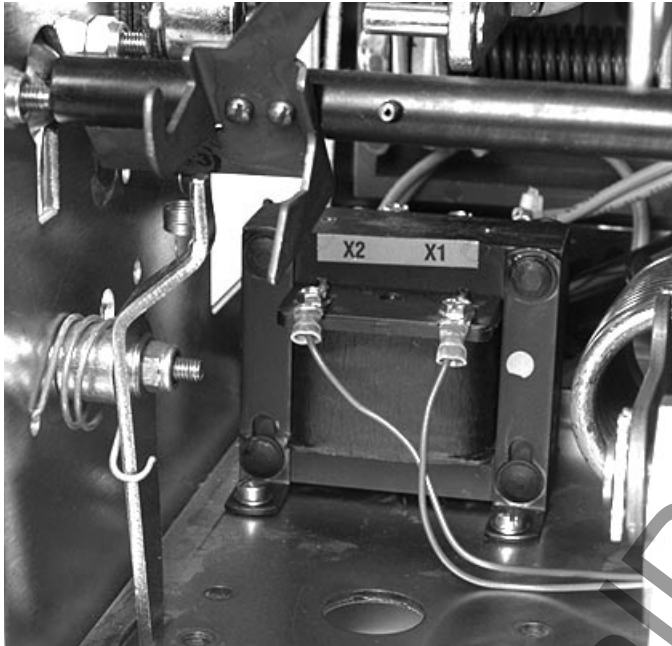
**STEP 5:**

Use the nylon wire ties provided to dress the wires and keep them away from any moving parts within the breaker.

STEP 6:

Route the External Harness through the notch cut in the Breaker Faceplate. Tuck any excess length of the ATR Wiring Harness down between the ATR and the Arc Chutes. Secure the External Harness and the ATR Wiring Harness in place with the self-adhesive wire clamps provided with the Retrofit Kit.



13 Installing the Sensors

See Pick List for Style Number



Note: Before beginning the Sensor installation, please read the following information carefully.

If you are changing the “rating” of the Breaker during the Retrofit process, the existing Sensors must be removed and replaced with the new Sensors supplied with the Retrofit Kit.

STEP 1:
Using the Primary Disconnect Tool, compress and remove the lower set of primary disconnecting contacts (finger clusters).

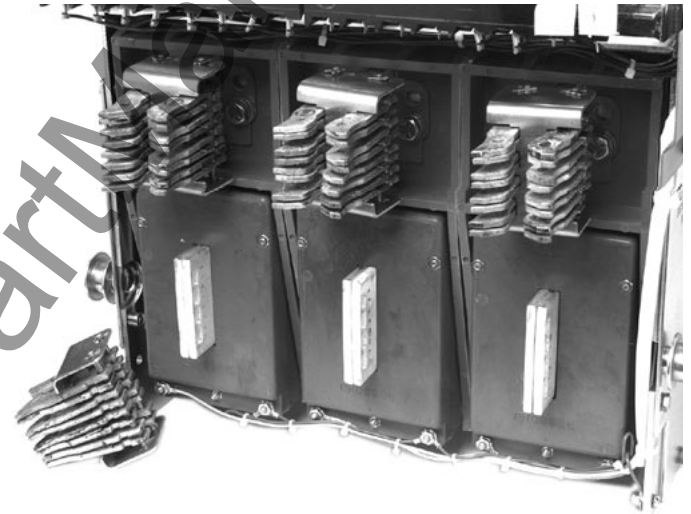

Digitrip Retrofit Components Provided:

<u>Description</u>	<u>Qty.</u>
Style Number (See Pick List)	
Sensor.....	3

STEP 2:
Tag the wire colors and the Sensor terminals to which each wire is connected. Remove the wires.

STEP 3:
Remove each of the Sensors from the studs.

STEP 4:
For DS 206 & DSL 206 Breakers Only. The Sensors on DS 206 & DSL 206 Breakers use small spacers (Style Number 794A965H01) for correct positioning. Remove these spacers from the original Sensors and set aside for use in Step 5.

STEP 5:

For DS 206 & DSL 206 Breakers Only. Install the spacers removed from the original Sensor in the inner windows of the new Sensors. They are necessary to assure correct positioning of the new Sensors.

Note: Order additional spacers (Style Number 794A965H01) if the original spacers are damaged or lost.

STEP 6:

Install the Sensors on the lower set of Breaker studs.

STEP 7:

Reinstall the wires that were tagged and removed from the original Sensors to their original position.

STEP 8:

Using the Primary Disconnect Tool, compress the primary disconnecting contacts and install them in their receptacles.

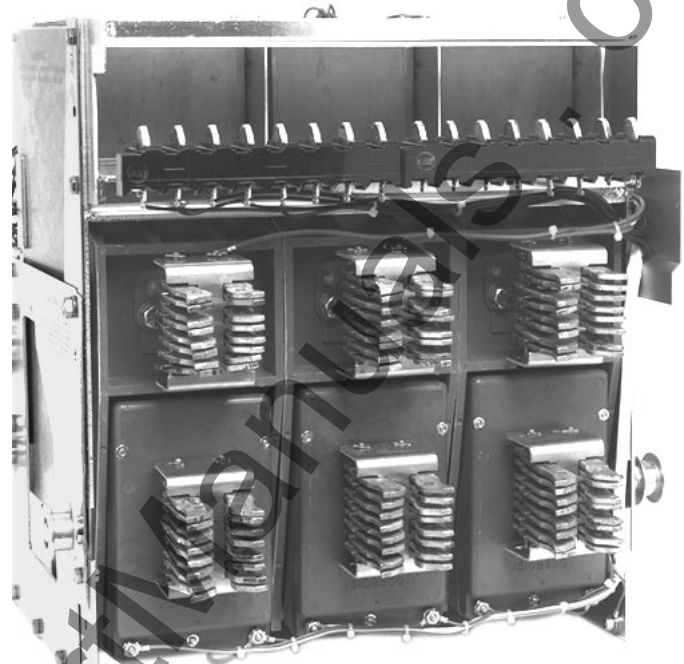

14

Testing the Breaker

Measure the force necessary to trip the Breaker at the point where the DTA flange nut contacts the Trip Finger. The force necessary to trip the Breaker **MUST NOT EXCEED** 3 lbs.

The Retrofit must be tested using primary injection. Refer to Section 8 of the *Instructions for the Application of Digitrip RMS Retrofit Kits on Power Circuit Breakers* (Publication AD-33-855-1, June, 1997), supplied with the Retrofit kit, for detailed testing procedures and specifications. For test information specific to the Trip Unit, refer to the IL publication supplied with the Retrofit kit (see the Pick List for the IL number).

While Section 8 of the *Instructions for the Application of Digitrip RMS Retrofit Kits on Power Circuit Breakers* provides the information necessary for testing the Breaker, please keep the following notes in mind when reviewing other sections of the publication.

CAUTION: For 610 and Communicating Trip Units: When all testing is complete, the Trip Unit must be reset. Failure to do so may cause the Battery in the Rating Plug to run down.

Notes:

1. Publication AD-33-855 was created specifically for the "hundred" series (500, 600, 700, etc.) Retrofit Kts. Therefore certain sections and figures do not apply to the "ten" series (510, 610, 810, etc.) Retrofit Kits. Specifically, these are Sections 13 and 14, as well as Figures 3-2, 3-3, and 3-4.

2. Sections 2-3, 3, 4, 5, 6, and 7, as well as Table 2-1 and 2-2, contain references to specific components and Style Numbers which are not applicable to the DS Breaker Retrofit Kts. The general information is still valid and useful reference, but the photographs, drawings, and Style Numbers are not applicable to DS Retrofits.

For All Kits Other Than 510 Basic.

If testing the Breaker with Short Delay or Ground Fault functions, be sure to either plug in the Cell Harness Assembly or use the Zone Interlock Shorting Plug detailed in Section 6, Step 4. Failure to do so may result in shorter than expected trip times.

For 810 and 910 Kits Only.

Without any power applied to the system (neither the 120 volt power supply nor the Aux. Power Module connected), plug the External Harness into the Cell Harness and check the impedance between COM 1 and COM 2. The impedance should be between 1 and 3 ohms. If the impedance is not within this range, trace the wiring and examine each connection to assure its integrity.

Confirm that the IMPACC communicating wiring is correct by following the procedures detailed in Section 7.4 of the *Instructions for the Application of Digitrip RMS Retrofit Kits on Power Circuit Breakers*. Note that for 810 and 910 Kits, the impedance between COM 1 and COM 2 should be between 1 and 3 ohms.

When the test is complete, disconnect the External Harness from the Cell Harness. Final External Harness Connection will be performed in Section 15.

15 Installing the Cell Harness Assembly

Pick List Style Number 6502C71 or 6506C34

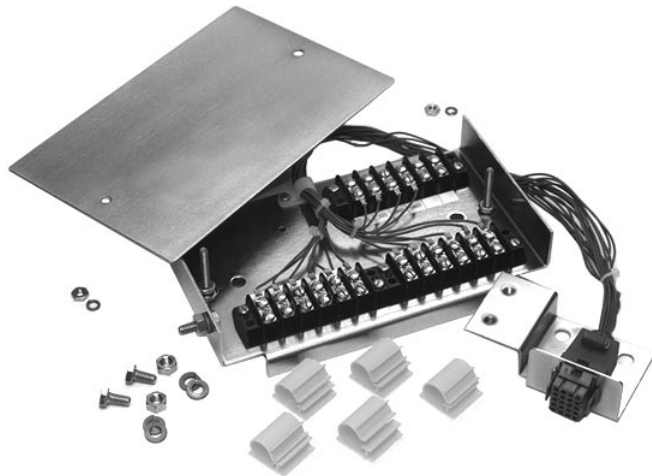

NOTICE

DIGITRIP RMS RETROFIT

CIRCUIT ZONE INTERLOCKS, REMOTE SIGNALS, AND/OR INCOM COMMUNICATIONS MAY BE COMPROMISED UNLESS TRIP UNIT, BREAKER, AND SWITCHGEAR CELL ARE MATCHED.

BREAKER ID NUMBER _____
 SWITCHGEAR CELL ID NUMBER _____
 TRIP UNIT CAT NO./INCOM ADDRESS _____

PLUG BREAKER UMBILICAL CORD INTO SWITCHGEAR CELL
 PLUG TO CONNECT REMOTE SIGNALS AND COMMUNICATIONS.

PN 8167A63H01

Digitrip Retrofit Components & Hardware Provided:

<u>Description</u>	<u>Qty.</u>
Style Number 6502C71 or 6506C34	
Cell Harness	1
Digitrip RMS ID Label	1
.250 - 20 × .750 Lng. Bolt - Stl.	2
.250 - 20 Nut Hex Stl.	2
.250 Flat Washer Stl.	4
.250 Lock Washer Stl.	4



WARNING

Before performing the following instructions, the Breaker must be removed from the Cell, and the primary and secondary power sources must be de-energized. Failure to do so could result in death, severe personal injury, and / or equipment damage.

STEP 1:

Locate the gas barrier on the right-hand side of the cell.

STEP 2:

Place the Terminal Block Assembly mounting plate against the right-hand side of the cell, behind the gas barrier. Position the mounting plate so that the two (2) mounting holes are centered, top-to-bottom, on the rear of the gas barrier.

STEP 3:

Once aligned, mark the hole locations on the gas barrier.

Note: For an alternative method of mounting to the cell side sheet, two (2) additional mounting holes are located in the Terminal Block Assembly mounting plate. Remove the Terminal Block Assembly cover to obtain access to these holes. Continue to mark and drill the side sheet as detailed below.

STEP 4:

Remove the right-hand side gas barrier from the Cell.

STEP 5:

Center punch the markings.

STEP 6:

Drill two (2) 0.312" holes in the center punched locations on the gas barrier.

STEP 7:

Using the original hardware, re-install the gas barrier in the Cell.

STEP 8:

Mount and secure the Terminal Block Assembly mounting plate to the gas barrier using the lock washers, flat washers, and nuts provided.

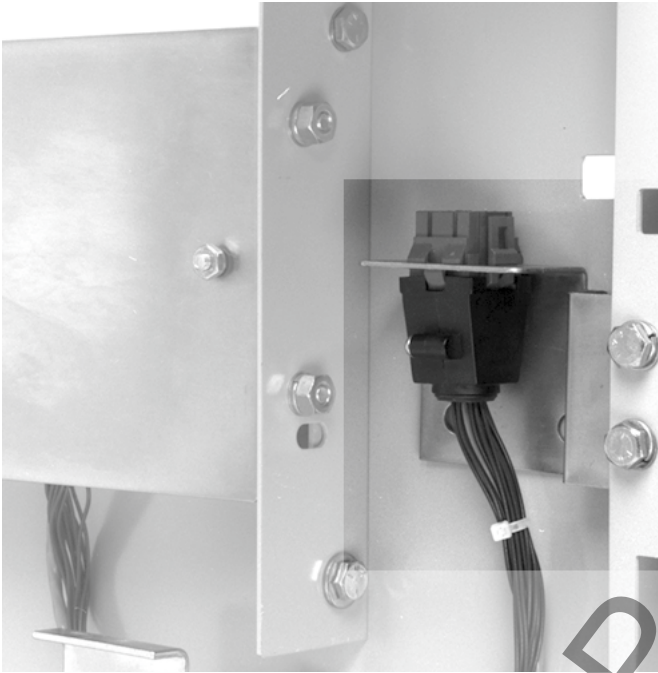
**STEP 9:**

Align the Cell Plug mounting bracket on the inside of the metal channel, opposite the right-hand gas barrier.

STEP 10:

Once aligned, mark the hole locations on the metal channel.

STEP 11:

Center punch the markings, then drill two (2) 0.312" holes in the center punched locations on the metal channel.

STEP 12:

Using the bolts, flat washers, lock washers, and nuts provided, mount the Cell Plug mounting bracket to the metal channel.

STEP 13:

Route the Cell Harness under the gas barrier and secure in place using the self-stick wire support clips provided.

**STEP 14:**

Install the Digitrip RMS Retrofit ID Label in a clearly visible location on the inside of the Cell door.

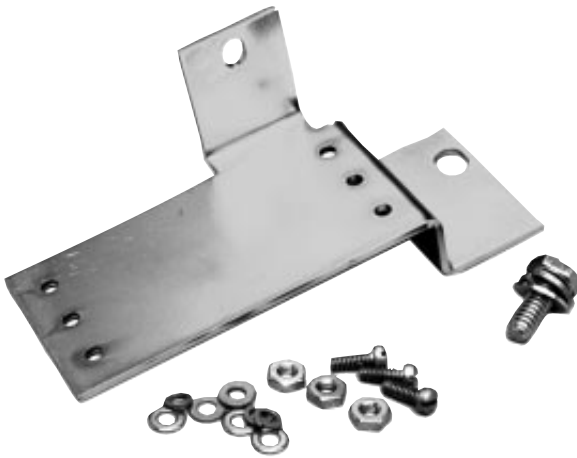
BF Addendum

Note: If the Breaker being Retrofitted is equipped with a BF Relay, contact Cutler-Hammer at 1-800-937-5487. The parts needed to reposition the BF Relay will be supplied free of charge. Once the parts are received, follow the procedures below before installing the Mounting Frame Assembly.

Digitrip Retrofit Components Provided:

<u>Description</u>	<u>Qty.</u>
Style Number 4A35807G01	
Mounting Bracket	1
.138-32 × .375 Lng. Screw - Fil.	3
.138 Flat Washer Stl.	6
.138 Lock Washer Stl.	3
.138-32 Nut Hex. Stl.	3
.250-20 × .625 Lng. Hex. Bolt	1
.250 Flat Washer Stl.	1
.250 Lock Washer Stl.	1

Step 1:

Working from the back of the Mounting Frame Assembly, remove the screw and washers from the bottom right corner of the Mounting Frame Assembly.

Step 2:

Align the BF Relay Mounting Bracket with the Mounting Frame Assembly, as shown. Using the hardware removed in Step 1, secure the BF Relay Mounting Bracket to the Mounting Frame Assembly.

**Step 3:**

Removed and scrap the hardware securing the BF Relay to the existing Mounting Bracket.

Step 4:

Remove and scrap the Original BF Relay Mounting Bracket and associated hardware from the Breaker.

Step 5:

Set the Mounting Frame Assembly on the Breaker Shelf. Secure the BF Relay to the Mounting Frame Assembly using the (3) .138-32 × .375 screws, (6) flat washers, (3) lock washers, and (3) nuts provided.

Step 6:

Refer to Section 6 of the manual and install the Mounting Frame Assembly on the Breaker.

Step 7:

Secure the bottom of the BF Relay Mounting Bracket to the Breaker using the (1) .250-20 × .625 bolt, (1) lock washer, and (1) flat washer provided.

Torque Values for General Mounting

Decimal Size (in)	Standard Size	Torque (in-lbs)	Torque (ft-lbs)
.112	4-40	10	0.8
.138	6-32	18	1.5
.164	8-32	36	3.0
.190	10-32	46	3.8
.250	1/4-20	100	8.3
.312	5/16-18	206	17.2
.375	3/8-16	356	29.7
.438	7/16-14	572	47.7
.500	1/2-13	856	71.3

Torque Values for Copper BUS Connections

Decimal Size (in)	Standard Size	Torque (in-lbs)	Torque (ft-lbs)
.250	1/4-20	60	5
.312	5/16-18	144	12
.375	3/8-16	240	20
.500	1/2-13	600	50

We wish to thank you for purchasing the Digitrip Retrofit System. Digitrip Retrofit Kits are designed and manufactured in America with pride. All the components are engineered to fit the existing Circuit Breaker with little or no modifications to the existing Breaker. However due to the wide variety and vintage of Breakers in use today, an occasional problem may arise. Please contact us with any questions, comments or concerns.

Phone: 1-800-937-5487 Fax. (724) 779-5899

The instructions for installation, testing, maintenance, or repair herein are provided for the use of the product in general commercial applications and may not be appropriate for use in nuclear applications. Additional instructions may be available upon specific request to replace, amend, or supplement these instructions to qualify them for use with the product in safety-related applications in a nuclear facility.

The information, recommendations, descriptions, and safety notations in this document are based on Cutler-Hammer's experience and judgement with respect to retrofitting of power breakers. This information should not be considered to be all inclusive or covering all contingencies. If further information is required, Cutler-Hammer should be consulted.

NO WARRANTIES, EXPRESSED OR IMPLIED, INCLUDING WARRANTIES OF FITNESS FOR A PARTICULAR PURPOSE OR MERCHANTABILITY, OR WARRANTIES ARISING FROM COURSE OF DEALING OR USAGE OF TRADE, ARE MADE REGARDING THE INFORMATION, RECOMMENDATIONS AND DESCRIPTIONS CONTAINED HEREIN. In no event will Cutler-Hammer be responsible to the user in contract, in tort (including negligence), strict liability or otherwise, for any special, indirect, incidental, or consequential damage or loss whatsoever, including but not limited to damage to or loss of use of equipment, plant or power system, cost of capital, loss of profits or revenues, cost of replacement power, additional expenses in the use of existing power facilities, or claims against the user by its customers resulting from the use of the information, recommendations, and descriptions contained herein.

Cutler-Hammer

130 Commonwealth Drive
Warrendale, PA 15086

Index

A

Amptector Trip Unit
Removing 5

B

BF Addendum 38
Breaker Faceplate
Modification 28

C

Cell Harness 36
Communications Wiring Harness 13
Control Power Transformer 20
Installation
Drilling Plan 20

D

Digitrip Trip Unit 6
Installing New Unit 16
Direct Trip Actuator 23
Drawing of Unit 23
Installing New Unit 24
Testing of Unit 23

E

External Harness 31
Installing 31

G

General Breaker Preparation 5

H

How to Use this Manual 2
HV Wires 21
To proper CPT terminals 21

M

Mounting Frame Assembly 15

O

Overcurrent Trip Switch 6
Installing New Switch 26
Removing Original Switch 6

P

Potential Transformer Module 11
Power Flow Convention 22
Power Relay Module 9
Installation 9

Q

Questions 2

R

Rating Plug 17

S

Safety Precautions 1
Sample Pick List 4
Sensors 33
Installing of 33

T

Technical Support 2
Testing the Breaker 35
Tools and Equipment Required 4
Torque Values 39
Trip Shaft Adjustment Screw 25
Trip Shaft Reset Spring 24
Installing New Spring 25
Removing Original Spring 24

W

Wire Guide 6
Installing New Guide 8
Removing Original Guide 6
Work Sequence 2
(Figure 1) 2

Z

Zone Interlock Shorting Plug 15