

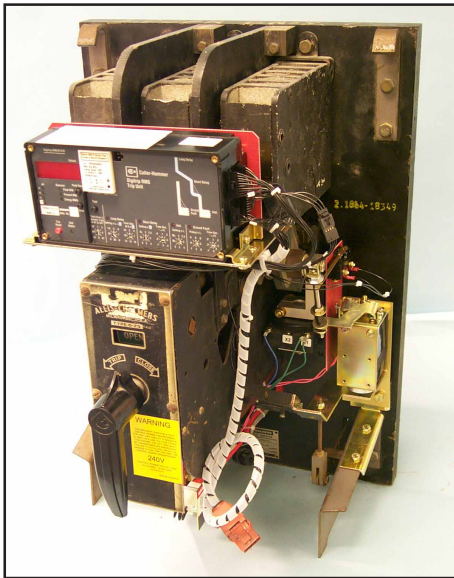

Digitrip Retrofit System for Allis-Chalmers G-25 Breakers



SAFETY PRECAUTIONS

WARNING

POWER CIRCUIT BREAKERS ARE EQUIPPED WITH HIGH SPEED, HIGH ENERGY OPERATING MECHANISMS. THE BREAKERS AND THEIR ENCLOSURES ARE DESIGNED WITH SEVERAL BUILT-IN INTERLOCKS AND SAFETY FEATURES INTENDED TO PROVIDE SAFE AND PROPER OPERATING SEQUENCES. TO PROVIDE MAXIMUM PROTECTION FOR PERSONNEL ASSOCIATED WITH THE INSTALLATION, OPERATION, AND MAINTENANCE OF THESE BREAKERS, THE FOLLOWING PRACTICES MUST BE FOLLOWED. FAILURE TO FOLLOW THESE PRACTICES MAY RESULT IN DEATH, PERSONAL INJURY, OR PROPERTY DAMAGE.

- Only qualified persons, as defined in the National Electric Code, who are familiar with the installation and maintenance of power circuit breakers and their associated switchgear assemblies should perform any work associated with these breakers.

- Completely read and understand all instructions before attempting any installation, operation, maintenance, or modification of these breakers.
- **Always turn off and lock out the power source feeding the breaker prior to attempting any installation, maintenance, or modification of the breaker. Do not use the circuit breaker as the sole means for isolating a high voltage circuit. Follow all lockout and tagging rules of the National Electric Code and all other applicable codes, regulations, and work rules.**
- Do not work on a closed breaker or a breaker with the closing springs charged. Trip (open) the breaker and be sure the stored energy springs are discharged before performing any work. The breaker may trip open or the charging springs may discharge, causing crushing or cutting injuries.
- For drawout breakers, trip (open), and then remove the breaker to a well-lit work area before beginning work.
- Do not perform any maintenance: including breaker charging, closing, tripping, or any other function which could cause significant movement of the breaker while it is on the extension rails. Doing so may cause the breaker to slip from the rails and fall, potentially causing severe personal injury to those in the vicinity.
- **Do not leave the breaker in an intermediate position in the switchgear cell. Always leave it in the connected, disconnected, or (optional) test position. Failure to do so could lead to improper positioning of the breaker and flashover, causing death, serious personal injury, and / or property damage.**
- **Do not defeat any safety interlock. Such interlocks are intended to protect personnel and equipment from damage due to flashover and exposed contacts. Defeating an interlock could lead to death, severe personal injury, and / or property damage.**



Digitrip Retrofit System for Allis-Chalmers G-25 Breakers

CONTENTS

Description

Introduction 5

Step 1: General Breaker Preparation 6

Step 2: Removing the Original Components 7

Step 3: Installing the Top Copper Adapters ... 10

Step 4: Installing the Bottom Copper Adapters and Sensors 11

Step 5: Installing the Aux. CT Module 13

Step 6: Connecting the Sensor Harness to the Aux. CT Module 18

Step 7: Connecting the PT and / or HV Wires 20

Step 8: Installing the Trip Finger and DTA Assembly 23

Step 9: Installing the Trip Unit 27

Step 10: Installing the External Harness and Final Wiring 29

Step 11: Testing the Breaker 32

Step 12: Mounting the Cell Harness 33

Step 13: Installing the Retrofitted Breaker in the Cell 34

Figures

1. Overview: Original Components Removed from the Breaker. 7

2. Measuring the Distance for Resetting the Interlock Mechanism. 7

3. Location of the Bottom Breaker Stab Mounting Hardware. 8

4. Trip Finger Removed from the Breaker 8

5. Location for the Hardware to be Removed to "Split" the Breaker. 9

6. Electromechanicals and Oil Dash Pots Removed from the Breaker. 9

7. Overview: Top Copper Adapters Installed with the Breaker "Halves" Reassembled. ... 10

8. Top Copper Adapters Mounted to the Stationary Contacts. 10

9. Breaker Halves Reassembled with New Top Copper Adapters Installed. 11

10. Overview: Bottom Copper Adapters and Sensors Installed in the Breaker. 11

11. Bottom Copper Adapters Secured to the Mounting Brackets. 12

12. Sensors Installed in the Breaker with Copper Adapter Cylinders In Place. 12

13. Sensor Harness Connected to the Sensors. 12

14. Overview: Aux. CT Module Installed in the Breaker. 13

15. Drilling Plan "A". 14

16. The .190" Wide Washer Installed on the Aux. CT Module. 14

17. PT Module and Insulation Barrier Installed on the PT Module Mounting Bracket. 14

18. PT Module Assembly Mounted to the Aux. CT Module. 14

19. Fuse Clips and Spade Connector Removed from the CPT. 15

20. CPT Module Installed on the CPT Module Mounting Bracket. 15



| | | | |
|---|----|---|----|
| 21. CPT Module Assembly Mounted to the Aux. CT Module. | 15 | 45. DTA Insulation Barrier Mounted to the DTA Assembly. | 25 |
| 22. CPT Harness Connected to the "X" Terminals of the CPT Module. | 16 | 46. DTA Assembly Mounted to the DTA Mounting Bracket. | 25 |
| 23. Load and Line Sides of the HV Wires. | 16 | 47. Reset Rod Connected to the Breaker Throw Bar. | 26 |
| 24. Load Side HV Wires Connected to the "H" Terminals of the CPT Module. | 17 | 48. Correct Orientation of the Auxiliary Switch Arm. | 26 |
| 25. Finger-Safe Covers Installed on the CPT Module. | 17 | 49. DTA Wires Secured to the Bottom Right Standoff. | 26 |
| 26. Aux. CT Module Assembly Installed in the Breaker. | 17 | 50. DTA Wires Connected to the Aux. CT Module Terminal Block. | 26 |
| 27. Routing of the PT Wires and HV Wires. | 18 | 51. Proper Cage Height Adjustment. | 27 |
| 28. Overview: Sensor Harness Connected to the Aux. CT Module. | 18 | 52. Proper Air Gap Adjustment. | 27 |
| 29. Sensor Harness Connected to the Aux. CT Module. | 19 | 53. Overview: Trip Unit Installed on the Breaker. | 27 |
| 30. Sensor Harness Secured to the Right Side of the Aux. CT Module. | 19 | 54. Mounting Brackets and Trip Unit Support Clips Mounted to the Insulation Barrier. | 27 |
| 31. Sensor Harness Secured to the Back of the PT Module Assembly. | 19 | 55. Trip Unit Installed on the Trip Unit Mounting Plate. | 28 |
| 32. Sensor Harness Secured to the CPT Assembly. | 20 | 56. Trip Unit Insulation Barrier Assembly Mounted to the Trip Unit and Mounting Plate. | 28 |
| 33. Overview: PT and HV Wires Connected to the Breaker. | 20 | 57. Trip Unit Assembly Mounted on the Breaker. | 28 |
| 34. PT Wires Connected to the Bottom Breaker Stabs. | 21 | 58. Rating Plug and Digitrip Retrofit Label Installed. | 29 |
| 35. PT Wires Secured to the Breaker Backplate. | 21 | 59. Overview: External Harness Installed on the Breaker. | 29 |
| 36. HV Wires Connected to the Top Breaker Stabs. | 22 | 60. Connection and Routing of the Aux. CT Harness. | 30 |
| 37. HV Wires Secured to the Breaker Backplate. | 22 | 61. 510 Basic Kit External Harness Shorting Plug. | 30 |
| 38. CPT Voltage Labels Supplied with the CPT Kit. | 23 | 62. Routing of the PT Extension Harness. | 30 |
| 39. Overview: Trip Finger and DTA Assembly Installed in the Breaker. | 23 | 63. External Harness Wires Connected to the Auxiliary Switch. | 31 |
| 40. Drilling Plan "B". | 23 | 64. External Harness Connections at the Trip Unit. | 31 |
| 41. Trip Finger Mounted to the Breaker Trip Bar. | 24 | 65. Harness Secured to the Trip Unit Mounting Plate. | 32 |
| 42. Resetting the Interlock Mechanism. | 24 | 66. Wires and Harnesses Routed Around the Lower Phase Barriers. | 32 |
| 43. DTA Mounting Bracket Installed on the Right Breaker Foot. | 24 | 67. Retrofit Components | 39 |
| 44. Microswitch Switch Mounted to the DTA Insulation Barrier. | 24 | | |

Tables

- 1. Available Retrofit Kits 5
- 2. Sensor Taps Rating 12
- 3. CPT Low Voltage Taps for Standard and Special Order CPTs (After Removing Fuse Clips) 16
- 4. CPT High Voltage Taps for Standard and Special Order CPTs 16
- 5. Torque Values for General Mounting and Screw Size Conversion 38
- 6. Torque Values for Copper BUS Connectors 38

www.ElectricalPartManuals.com

INTRODUCTION

Cutler-Hammer Digitrip Retrofit Kits are available in a number of configurations that provide a wide range of features. The Digitrip System starts with the 510 Basic Kit which offers true RMS sensing, overcurrent protection, and self-testing features. Advanced Digitrip Retrofit Kits feature zone interlocking, digital alphanumeric displays, remote alarm signals, PowerNet communications, energy monitoring capabilities, power factors, and harmonic content measurements.

Table 1 provides a quick reference of the components supplied with each level of Retrofit Kit. Before beginning the Retrofit process, take a minute to review the information contained in Table 1. It is important that the Retrofitter understands which

level of Retrofit Kit is to be installed and which components are included with the Kit.

The instructions contained in this manual cover the installation of all levels of Retrofit Kit. If the Kit you are installing does not contain a certain component, skip the instructions for that component and proceed to the next.

Throughout the Retrofit process, refer to the Torque Tables at the back of this manual for specific torque values.

If you have any questions concerning the Retrofit Kit and / or the Retrofit process, contact Cutler-Hammer at: 1-800-937-5487.

Table 1 Available Retrofit Kits

| Components | 510 Basic | 510 with Zone Interlock | 610 | 810 | 910 |
|---|-----------|-------------------------|---------------------|---------------------|---------------------|
| Trip Unit | | | | | |
| Rating Plug | | | | | |
| Auxiliary Current Transformer (CT) Module | | | | | |
| Auxiliary CT Harness | | | | | |
| Sensors | | | | | |
| Sensor Harness | | | | | |
| Direct Trip Actuator (DTA) | | | | | |
| Mounting Brackets and Hardware | | | | | |
| External Harness | Plug | 1 Connector Harness | 2 Connector Harness | 4 Connector Harness | 4 Connector Harness |
| Cell Harness | | | | | |
| Breaker Mounted Control Power Transformer (CPT) | | | | | |
| Potential Transformer (PT) Module | | | | | |
| Auxiliary Switch | | | | | |

STEP 1: GENERAL BREAKER PREPARATION

Before attempting to remove the Breaker from the Cell or perform any Retrofit Operation, be sure to read and understand the Safety Precautions section of this manual. In addition, be sure to read and understand the Instructions for the Application of Digitrip RMS Retrofit Kits on Power Circuit Breakers (Retrofit Application Data - Publication AD 33-855-4), supplied with the Digitrip Retrofit Kit.



WARNING

DO NOT ATTEMPT TO INSTALL OR PERFORM MAINTENANCE ON EQUIPMENT WHILE IT IS ENERGIZED. SEVERE PERSONAL INJURY OR DEATH CAN RESULT FROM CONTACT WITH ENERGIZED EQUIPMENT. VERIFY THAT NO VOLTAGE IS PRESENT BEFORE PROCEEDING.

- A. Trip the Breaker and remove it from the Cell.
Move the Breaker to a clean, well-lit work area.

NOTE: It is the responsibility of the Retrofitter to insure that the Breaker and all original components are in good condition. Visually inspect all Breaker components for signs of damage or wear. If any signs of damage or wear are detected for components not included in the Retrofit Kit, secure the necessary replacement parts before beginning the Retrofit Process.

The force necessary to trip the Breaker should not exceed three (3) lbs.

NOTE: It is the responsibility of the Retrofitter to insure that the proper, manufacturer's recommended crimping tools and terminals are used for each type of connector. It is also the responsibility of the Retrofitter to insure that all wire preparations, connections, strippings, terminations, and wiring techniques are performed according to the latest IEEE, NEC, and / or NEMA industry standards, specifications, codes, and guidelines.

To begin the Retrofit Process, refer to the components list at the end of this manual. Layout the components and hardware according to the steps outlined. The parts bags are labeled with the corresponding step number. The components and hardware will be used to complete each step in the Retrofit Process.

STEP 2: REMOVING THE ORIGINAL COMPONENTS

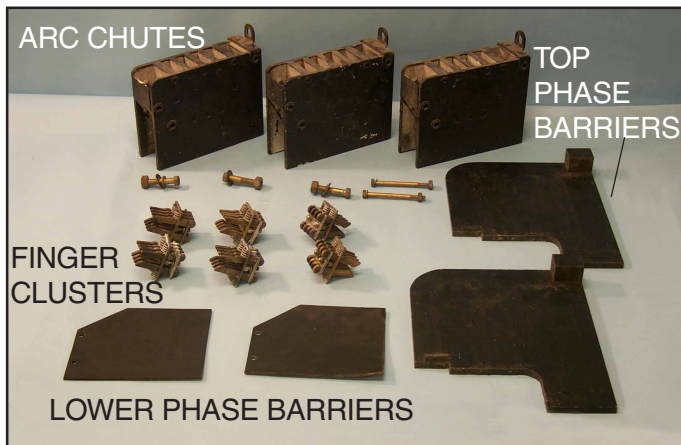

Fig. 1 Overview: Original Components Removed from the Breaker.

Refer to the Allis-Chalmers G-25 Instruction Manual, originally supplied with the Breaker, to perform the following procedures.

- A. Before removing any components from the Breaker, measure and record the distance between the bottom of the nut on the Interlock Mechanism Rod and the top surface of the Trip Finger. This distance will be used during the Retrofit process to insure that the Interlock Mechanism is reset correctly.

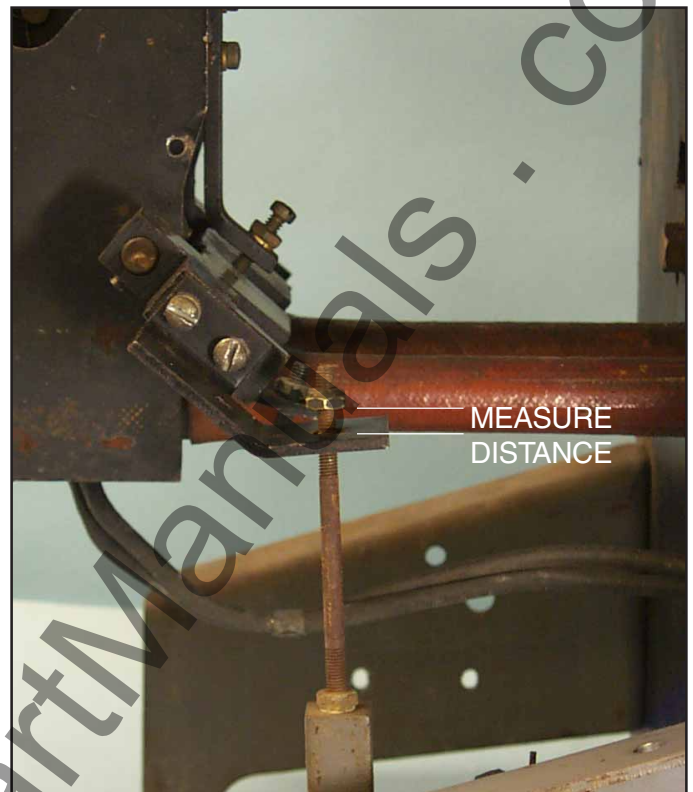

Fig. 2 Measuring the Distance for Resetting the Interlock Mechanism.

- B. Remove and save the bottom Finger Clusters and mounting hardware.
- C. Remove and scrap the mounting hardware securing the bottom Breaker Stabs to the mounting brackets on the rear of the Breaker Backplate.

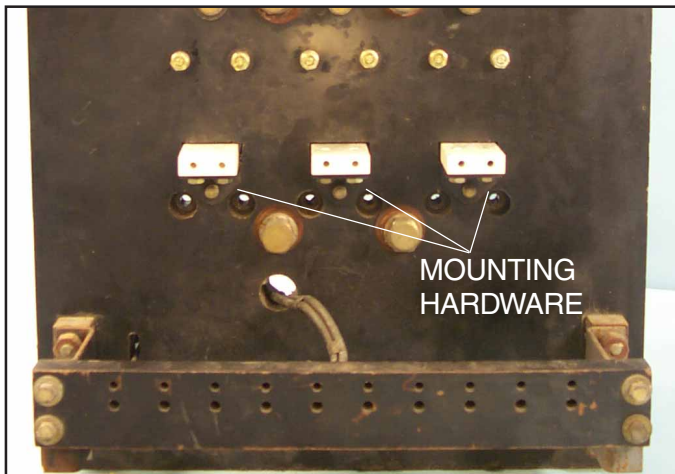

Fig. 3 Location of the Bottom Breaker Stab Mounting Hardware.

Note: The Phase Barriers and Arc Chutes are made of asbestos and are easily damaged if not handled properly. Care should be taken during removal and installation to insure that they are not damaged.

- D. Remove and save the top Phase Barriers and mounting hardware.
- E. Remove and save the Arc Chutes and mounting hardware.
- F. Remove and save the lower Phase Barriers and mounting hardware.
- G. Remove and scrap the adjusting nut from the Interlock Mechanism Rod.
- H. Remove the Trip Finger from the right end of the Breaker Trip Bar. Scrap the Trip Finger but save the mounting hardware.



Fig. 4 Trip Finger Removed from the Breaker.

Note: During the following steps, the Breaker halves are “split”. It is strongly advised that an assistant be present to help with this procedure.

- I. Remove and save the six (6) bolts securing the Stationary Contacts to the Breaker Backplate.
- J. Remove and save the four (4) bolts securing the Center Mechanism stand-offs to the Breaker Backplate. As these bolts are being removed, the Center Mechanism will begin “splitting” from the Breaker Backplate. Have your assistant hold the Center Mechanism so it does not fall away and become damaged. Once it is loose from the Breaker Backplate, set the Center Mechanism on the work surface.

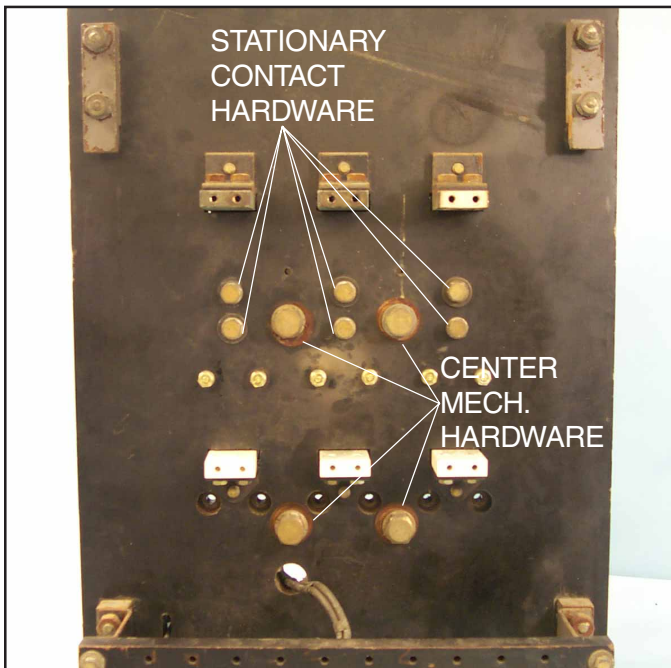

Fig. 5 Location for the Hardware to be Removed to "Split" the Breaker.

Note: In the following steps, the Electromechanicals and Oil Dash Pots are removed. Because of the age of the Breaker, oil tends to seep from the Dash Pots. The Retrofitter is advised to have a means available to "catch" any oil that may seep from the Dash Pots during removal.

- K. Remove and scrap the springs connecting the Electromechanicals to the Breaker Trip Bar.
- L. Remove and scrap the mounting hardware securing the Electromechanicals to the Breaker Backplate. Remove and scrap the Electromechanicals and the attached Oil Dash Pots.



Fig. 6 Electromechanicals and Oil Dash Pots Removed from the Breaker.

M. Before continuing with the Retrofit, the remaining original Breaker components should be cleaned to remove any foreign matter or oil that may be present.

STEP 3: INSTALLING THE TOP COPPER ADAPTERS

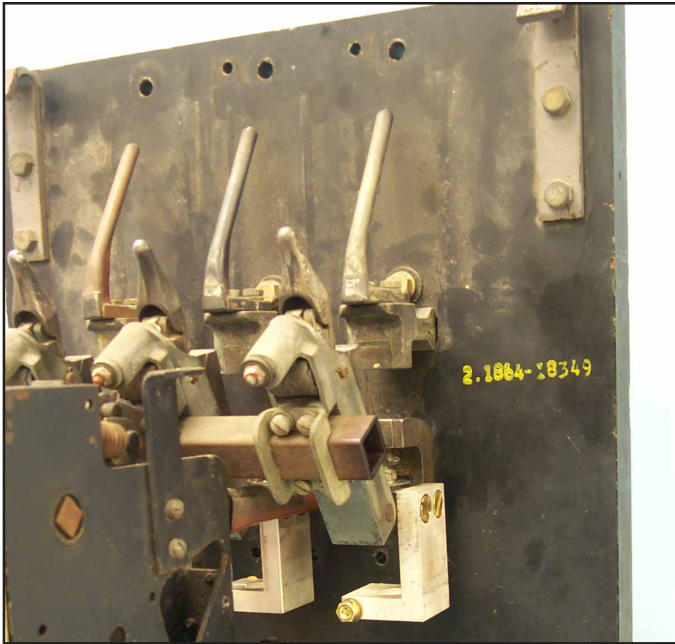

Fig. 7 Overview: Top Copper Adapters Installed with the Breaker "Halves" Reassembled.

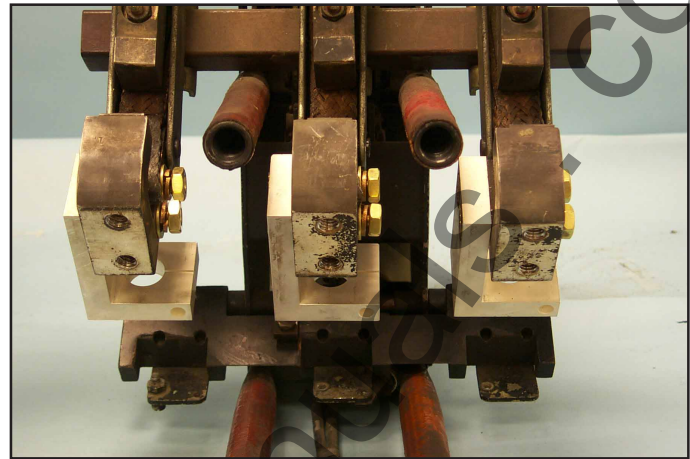

Fig. 8 Top Copper Adapters Mounted to the Stationary Contacts.

- A. Align the two (2) holes in the top of each "L"-shaped top Copper Adapter with the same existing holes in the Stationary Contacts that were used to mount the Electromechanicals. Note that the bottom leg of the "L" should point toward the left side of the Breaker. Firmly secure the top Copper Adapters to the Stationary Contacts using the (6) .313-18 x 2.00" brass flat head screws, (6) brass flat washers, (6) bronze lock washers, and (6) brass nuts supplied.
- B. Using the (3) .250-20 x 2.00" brass bolts, (6) brass flat washers, (3) bronze lock washers, and (3) brass nuts supplied, slide one (1) pinch bolt with flat washer into the existing hole in the bottom leg of each top Copper Adapter. Then install one (1) flat washer, one (1) lock washer, and one (1) nut on each bolt. Do not tighten the hardware at this time. The hardware will be tightened later in the Retrofit process.
- C. With the help of an assistant, align the Breaker Center Mechanism with the Breaker Back Plate. Using the four (4) original bolts removed in Step 2-J, loosely secure the Center Mechanism to the Breaker Backplate. Using the six (6) original bolts removed in Step 2-I, loosely secure the Stationary Contacts to the Breaker Backplate. Once all the holes are aligned and bolts started, completely tighten all ten (10) bolts to O. E. M. specifications.

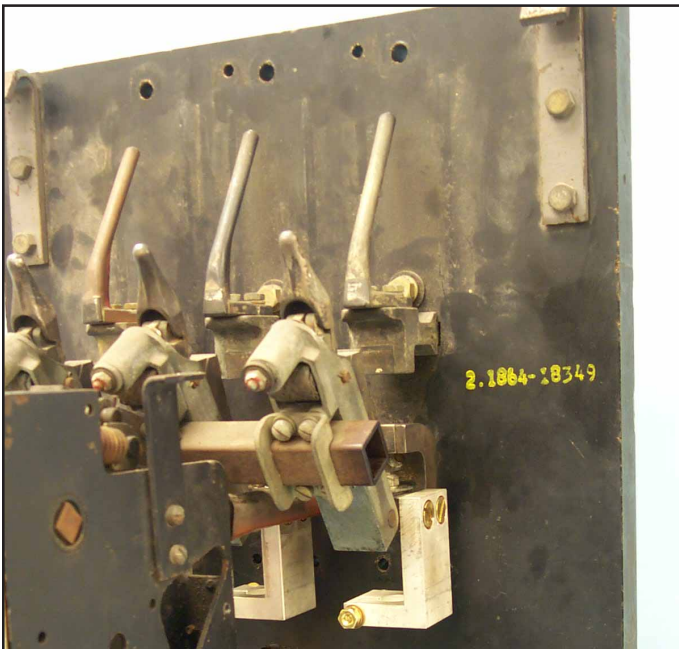

Fig. 9 Breaker Halves Reassembled with New Top Copper Adapters Installed.

STEP 4: INSTALLING THE BOTTOM COPPER ADAPTERS AND SENSORS

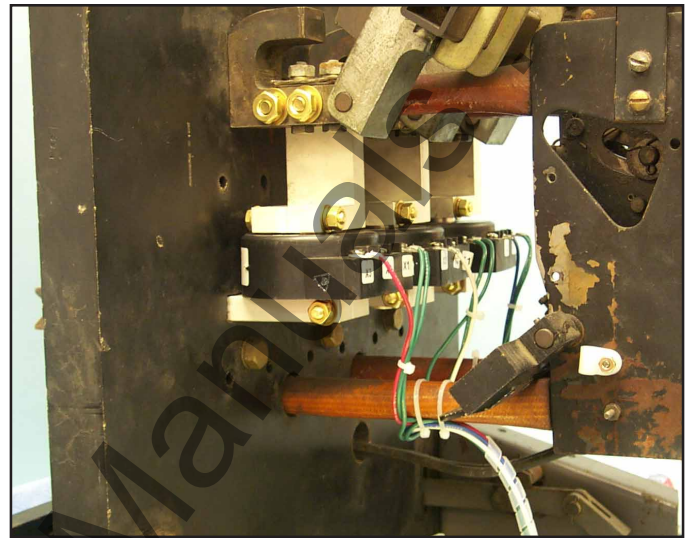

Fig. 10 Overview: Bottom Copper Adapters and Sensors Installed in the Breaker.

- A. Using the (3) .250-20 x 2.00" brass bolts, (6) brass flat washers, (3) bronze lock washers, and (3) brass nuts supplied, prepare the bottom Copper Adapters for installation by inserting a "pinch" bolt with flat washer in the hole each Adapter. Install one (1) flat washer, one (1) lock washer, and one (1) nut on each pinch bolt. Do not tighten the hardware at this time. The hardware will be tightened later in the Retrofit process.
- B. Slide a bottom Copper Adapter through the existing slots in the Breaker Backplate. Align the two (2) holes in each bottom Copper Adapter with the holes in the bottom Breaker Stab mounting brackets on the rear of the Breaker Backplate. Using the (6) .250-20 x .750" brass bolts and (6) bronze lock washers supplied, loosely secure the bottom Copper Adapters to the mounting brackets.

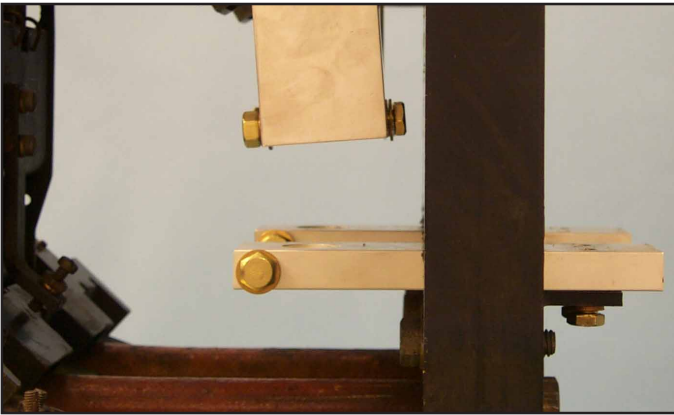

Fig. 11 Bottom Copper Adapters Secured to the Mounting Brackets.

- C. Working from the front of the Breaker, slide a Sensor between each set of top and bottom Copper Adapters as shown. Insure that the Sensors are positioned with the terminals facing the front and top of the Breaker.
- D. Slide a Copper Adapter Cylinder up through the bottom Copper Adapter, through the Sensor, and into the top Copper Adapter. Once the cylinder is flush with the top surface of the top Copper Adapter, secure the Adapter Cylinder by tightening the pinch bolts in the top and bottom Adapters.



Fig. 12 Sensors Installed in the Breaker with Copper Adapter Cylinders In Place.

- E. Tighten the hardware that secures the bottom Copper Adapters to the bottom Breaker Stab mounting brackets.
- F. Connect the ring terminals of the Sensor Harness to the Sensor Terminals. The Sensor Harness supplied with the Retrofit Kit has extra long leads to allow routing of the Sensor Harness around the various components of the Breaker. When installing the Sensor Harness, be sure to route the wires so they will clear the Breaker Trip Bar and the lower Phase Barriers when reinstalled later in the Retrofit process.

Refer to Section 12 of the Application Data, supplied with the Retrofit Kit, for detailed wiring specifications.

For G-25 Retrofits, the following conventions apply.

Table 2 Sensor Taps Rating

| Sensor Style No. | Terminal Com. | Amps |
|------------------|---------------|-------|
| 4A35743H01 | X1 - X2 = | 300 A |
| | X1 - X3 = | 600 A |



Fig. 13 Sensor Harness Connected to the Sensors.

- G. Temporarily route the Sensor Harness between the bottom Center Mechanism stand-offs, then towards the bottom left of the Breaker. Final Sensor Harness routing and connections will be performed later in the Retrofit process.
- H. Reinstall the bottom Finger Clusters using the original mounting hardware removed in Step 2-B.

For Kits Supplied with a PT Module Only: Do not fully tighten the Finger Cluster mounting hardware at this time. This hardware will be used later in the Retrofit process to connect the PT Wires.

STEP 5: INSTALLING THE AUX. CT MODULE

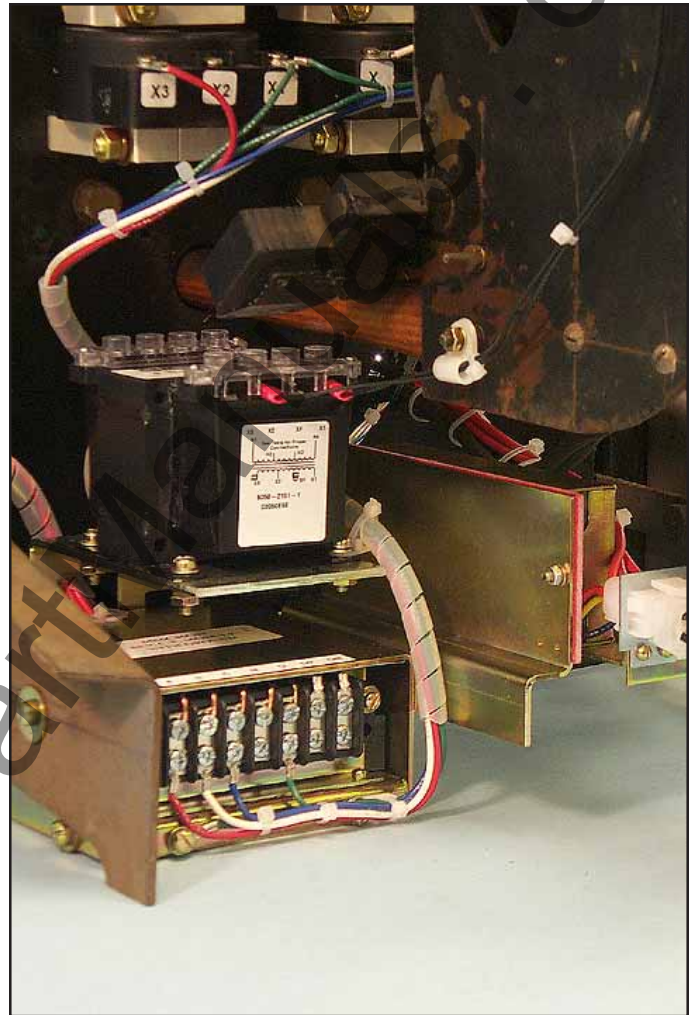

Fig. 14 Overview: Aux. CT Module Installed in the Breaker.

- A. Using Drilling Plan "A", drill two (2) .218" diameter holes in the left front Breaker Foot.

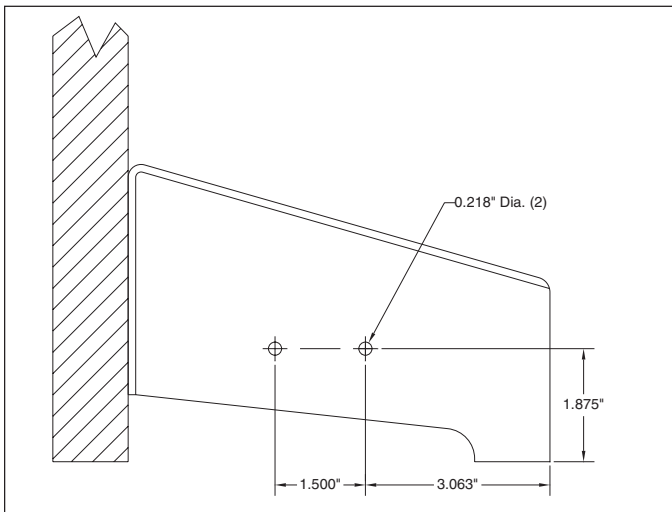

Fig. 15 Drilling Plan "A".

- B. Remove the screw and washer from the right front side of the Aux. CT Module. Scrap the original washer. Replace the original washer with the (1) .190" "wide" flat washer supplied then reinstall the original screw.

Note: The .190" "wide" washer is used to "space" the Aux. CT Module away from the left Breaker Foot when the Aux. CT Module is installed later in the Retrofit process.



Fig. 16 The .190" Wide Washer Installed on the Aux. CT Module.

For Kits Supplied with a PT Module Only.

- C. Align the PT Module and the Insulation Barrier with the existing holes in the PT Module Mounting Bracket as shown. Secure the PT Module and the Insulation Barrier to the mounting bracket using the (2) .138-32 x .500" screws, (4) flat washers, (2) lock washers, and (2) nuts supplied.

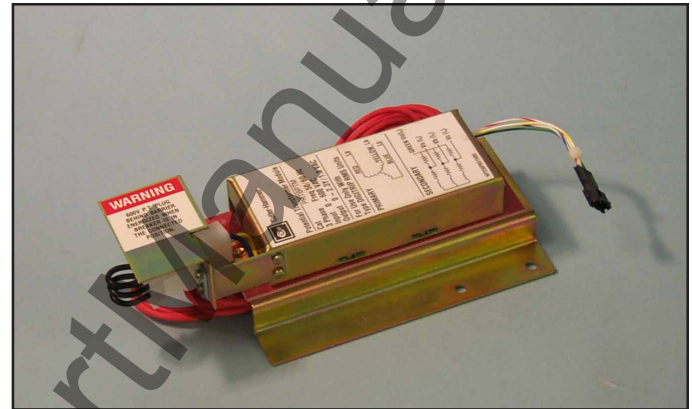

Fig. 17 PT Module and Insulation Barrier Installed on the PT Module Mounting Bracket.

- D. Align the PT Module Assembly, as shown, with the existing holes in the top right side of the Aux. CT Module. Secure the PT Module Assembly to the Aux. CT Module using the (2) .190-16 x .500" thread cutting screws, (2) flat washers, and (2) lock washers supplied.

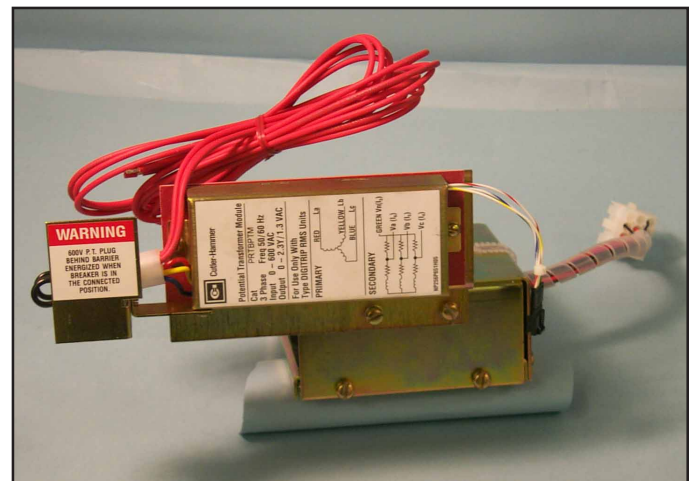

Fig. 18 PT Module Assembly Mounted to the Aux. CT Module.

For Kits Supplied with a Breaker Mounted CPT Module Only.

- E. Remove and save the (2) .190 - 32 × .250" screws securing the fuse clips and male spade connector installed on the CPT. Discard the fuse clips and spade connector, then reinstall the screws in the CPT Terminals.



Fig. 19 Fuse Clips and Spade Connector Removed from the CPT.

- F. Align the Breaker Mounted CPT Module with the existing holes in the CPT Mounting Brackets as shown. Secure the CPT Module to the mounting bracket using the (4) .190-32 × .750" screws, (8) flat washers, (4) lock washers, and (4) nuts supplied. Two (2) Panduit cable mounts should also be installed using the right side mounting hardware. These will be used later in the Retrofit process to secure the Sensor Harness.

Note: The "H" Terminals of the CPT Module should be oriented toward the notched side of the CPT Mounting Bracket.

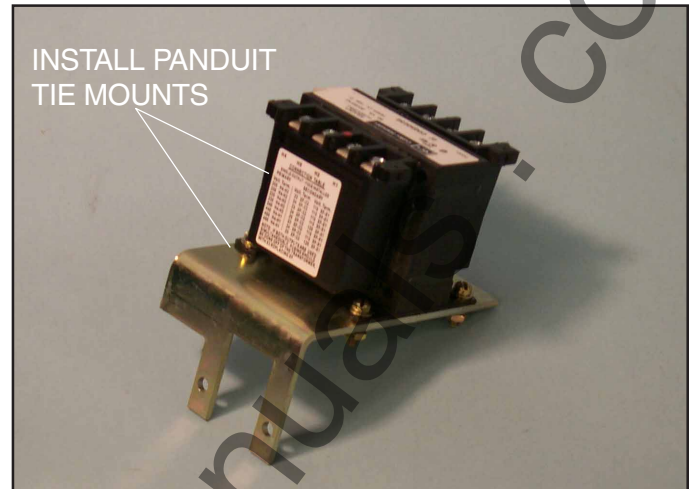

Fig. 20 CPT Module Installed on the CPT Module Mounting Bracket.

- G. Align the CPT Module Assembly with the existing holes at the top of the back of the Aux. CT Module as shown. Secure the CPT Module Assembly to the Aux. CT Module using the (2) .190-16 × .500" thread cutting screws, (2) lock washers, and (2) flat washers supplied.

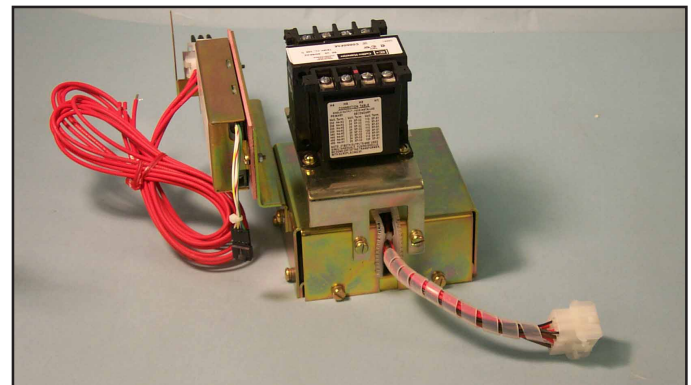

Fig. 21 CPT Module Assembly Mounted to the Aux. CT Module.

- H. Connect the CPT Harness wires to the appropriate "X" terminals of the CPT Module as shown. See Table 3 for Tap information.

Table 3 CPT Low Voltage Taps for Standard and Special Order CPTs (After Removing Fuse Clips)

| Standard CPT (Style #9A10037G01 & G02) | |
|---|---------------------------|
| <i>120 Voltage Required</i> | <i>CPT Terminals Used</i> |
| Secondary Circuit | X1 & X2 |
| Special Order 575 Volt CPT (Style #9A10037G03 & G04) | |
| Secondary Circuit | X2 & X3 |

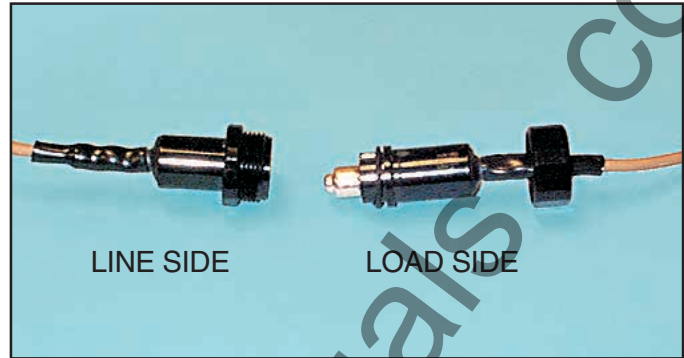

Fig. 23 Load and Line Sides of the HV Wires.

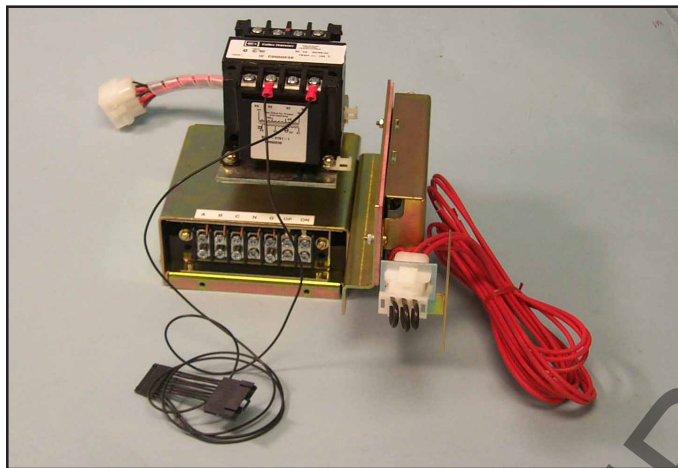

Fig. 22 CPT Harness Connected to the "X" Terminals of the CPT Module.

NOTE: The Load Side HV Wires are longer than necessary and are cut during the following steps. Before cutting the wires, be sure that sufficient length is left so that the HV Wire Fuses can rest near the right side of the Aux. CT Module and that the connections can be made to the correct "H" terminals on the CPT Module.

- I. Position the HV Fuses along the right side of the Aux. CT Module. Mark and cut the Load Side of each HV Wire to an appropriate length for connection to the "H" terminals of the CPT. Strip an appropriate length of insulation from the Load Side HV Wires and attach a .138" ring terminal to each. Attach the HV Wires to the CPT "H" terminals to achieve the required voltage (see Table 4).

NOTE: The terminals to which the Load Side HV wires are connected determine the voltage of the CPT. Verify that the line voltage of the circuit matches the CPT voltage BEFORE putting the Breaker into service.

Table 4 CPT High Voltage Taps for Standard and Special Order CPTs

| Standard CPT (Style #9A10037G01 & G02) | |
|---|---------------------------|
| <i>Voltage Required</i> | <i>CPT Terminals Used</i> |
| 480 Volt Circuit | H1 & H4 |
| 240 Volt Circuit | H2 & H4 |
| 208 Volt Circuit | H3 & H4 |
| Special Order 575 Volt CPT (Style #9A10037G03 & G04) | |
| 575 Volt Circuit | H1 & H4 |
| 460 Volt Circuit | H2 & H4 |
| 230 Volt Circuit | H3 & H4 |

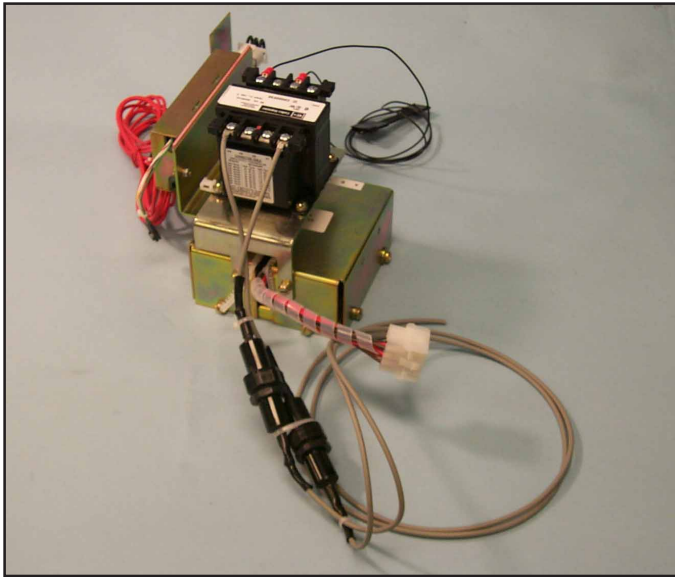

Fig. 24 Load Side HV Wires Connected to the "H" Terminals of the CPT Module.

- J. After the HV and CPT Wires have been connected to the proper terminals of the CPT, install the "A" and "B" Finger-Safe Covers over the CPT Terminals as shown. Secure the Finger-Safe Covers to the CPT using the (4) .098 - 28 x .375" screws supplied with the CPT Kit. Torque the screws to 8 - 10 in./lbs.

NOTE: The "C" and "D" Finger-Safe Covers supplied with the CPT Kit are not used in this application and should be discarded.

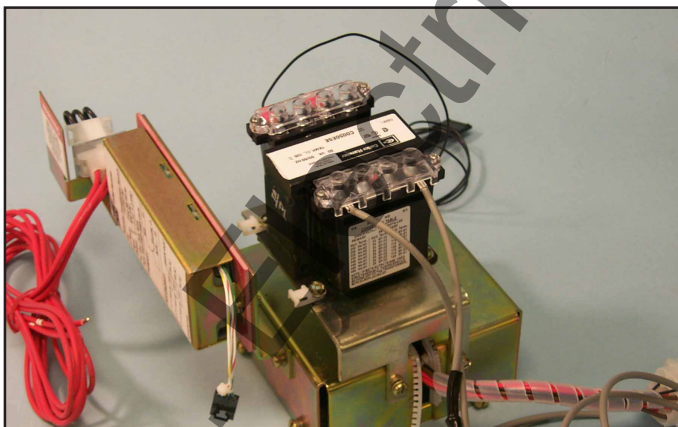

Fig. 25 Finger-Safe Covers Installed on the CPT Module.

For All Retrofit Kits.

- K. Align the Aux. CT Module Assembly with the holes drilled in the left Breaker Foot in Step 5-A. Secure the Aux. CT Module Assembly to the Breaker Foot using the (2) .190-16 x .500" thread cutting screws, (2) lock washers, and (2) "extra wide" (.750") flat washers supplied.



Fig. 26 Aux. CT Module Assembly Installed in the Breaker.

- L. For Kits Supplied with a PT Module Only: Route the PT Wires towards the rear of the Breaker, then through the existing hole in the Breaker Backplate.
- M. For Kits Supplied with a Breaker Mounted CPT Only: Route the Line Side HV Wires towards the rear of the Breaker, then through the existing hole in the Breaker Backplate. Insure that the HV Fuses are in an accessible location.

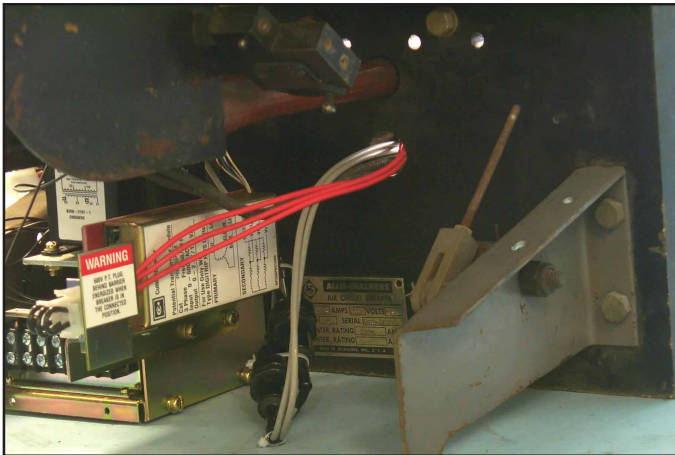

Fig. 27 Routing of the PT Wires and HV Wires.

STEP 6: CONNECTING THE SENSOR HARNESS TO THE AUX. CT MODULE

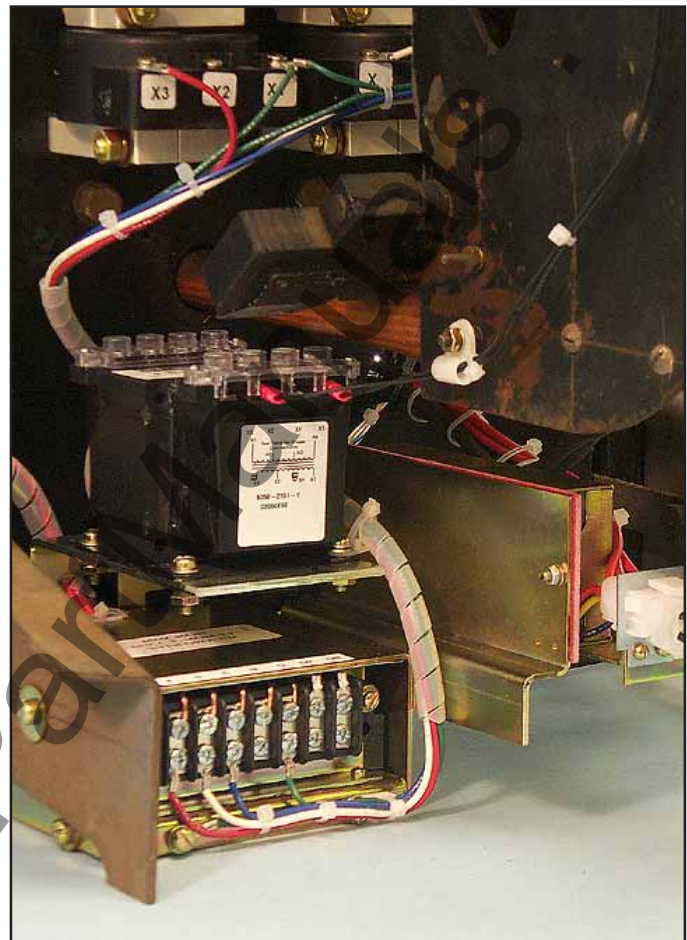

Fig. 28 Overview: Sensor Harness Connected to the Aux. CT Module.

- A. Connect the Sensor Harness to the proper terminals of the Aux. CT Module Terminal Block. Refer to Section 12 of the Retrofit Application Data, supplied with the Retrofit Kit, for detailed wiring specifications.

Note that the Sensor Harness Ground Wire (with ring terminal) is connected to the body of the Aux. CT Module using the existing left front hole and the (1) .190-16 x .500" thread cutting screw, (1) lock washer, and (1) flat washer supplied. Also note that the (1) Panduit tie mount, (1) nylon wire tie, (1) .190-16 x .500" thread cutting screw, (1) lock washer, and (1) flat washer are used to secure the Sensor Harness to the front of the Aux. CT Module.

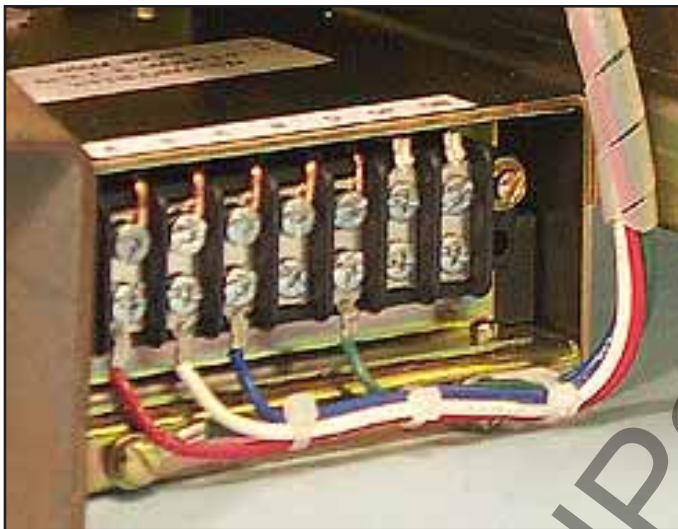

Fig. 29 Sensor Harness Connected to the Aux. CT Module.

Note: There are three (3) methods that can be used to secure the Sensor Harness away from moving parts within the Breaker. The method to use is dependent on the components purchased with your Retrofit Kit. Read the following sections carefully to determine the method that should be used.

Method 1: No PT Module or Breaker Mounted CPT Module.

- B. Install the (2) Panduit cable mounts on the top right side of the Aux. CT Module using the (2) .190-16 x .500" thread cutting screws and (2) lock washers supplied.
- C. Secure the Sensor Harness to the Panduit cable mounts using the (2) wire ties supplied.



Fig. 30 Sensor Harness Secured to the Right Side of the Aux. CT Module.

Method 2: For Kits Supplied with a PT Module Only.

- B. Install the (1) self-adhesive tie mount on the back of the PT Module Assembly.
- C. Secure the Sensor Harness to the back of the PT Module Assembly using the (1) wire tie supplied.

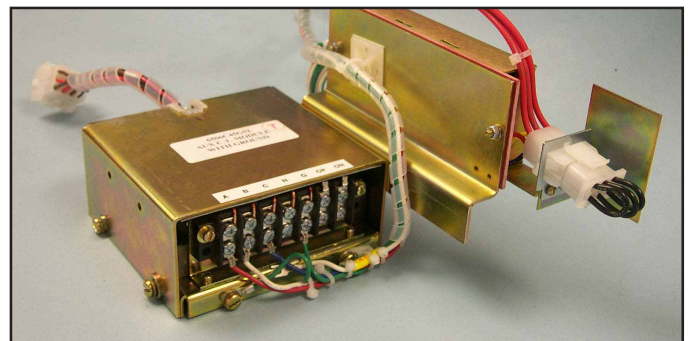

Fig. 31 Sensor Harness Secured to the Back of the PT Module Assembly.

Method 3: For Kits Supplied with a Breaker Mounted CPT Only.

- B. Secure the Sensor Harness to the Panduit cable mounts on the CPT Assembly, installed in Step 5-F, using the (2) wire ties supplied.

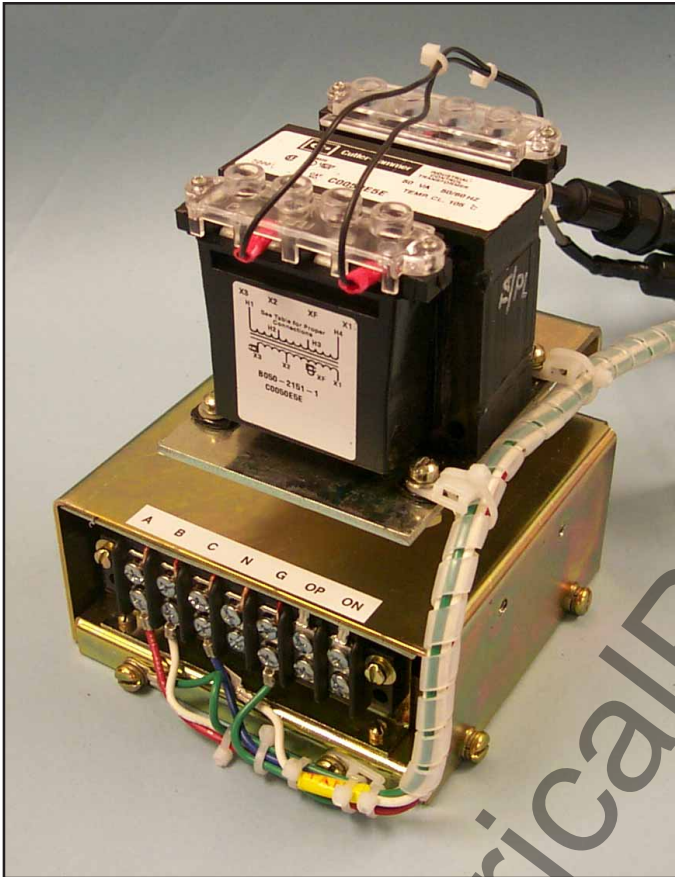

Fig. 32 Sensor Harness Secured to the CPT Assembly.

For Kits Supplied with a PT Module and / or Breaker Mounted CPT Only.

STEP 7: CONNECTING THE PT AND / OR HV WIRES

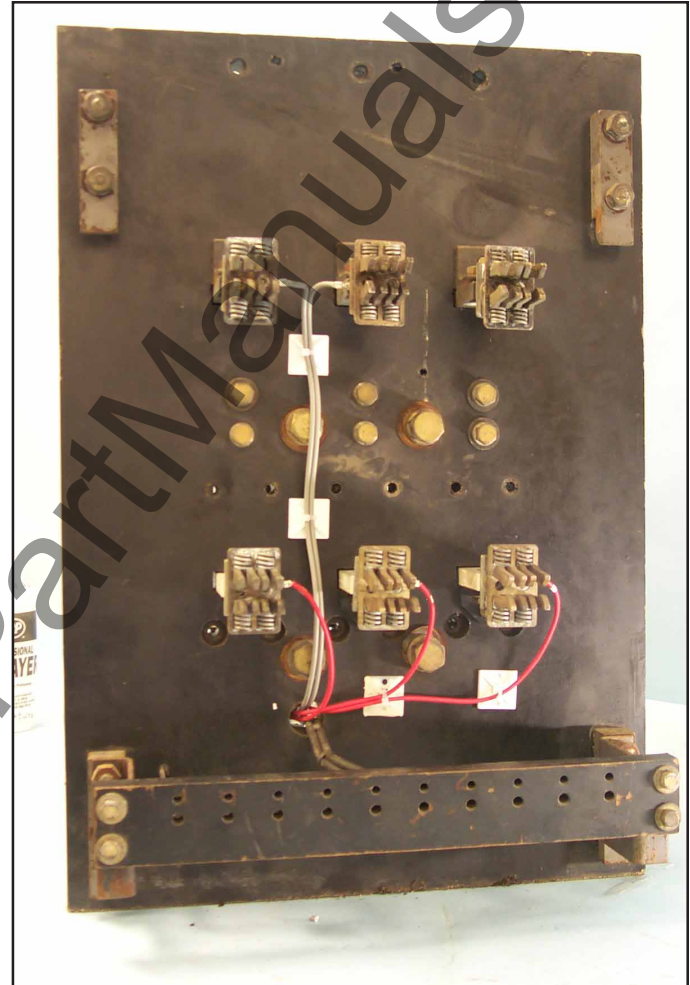

Fig. 33 Overview: PT and HV Wires Connected to the Breaker.

For Kits Supplied with a PT Module Only.

- A. Remove one (1) of the cap screws, left loose in Step 4-H, from each bottom Finger Cluster.
- B. The PT Wires are marked for connection to Phases 1, 2, and 3 with corresponding numbers.

NOTE: Before cutting the PT Wires, verify the Phase Convention used on the Breaker Application.

Route the PT Wires to a position suitable for attachment between the bottom Finger Clusters and the bottom Breaker Stabs. Move the PT Wire markers to a position where they will still be attached to the wires after cutting. Cut the wires to the appropriate length, strip each wire .250", and install a .250" ring terminal on each wire.

- C. Insert each PT Wire Ring Terminal between the back of the Finger Clusters and the end on the Breaker Stabs as shown. Insert the cap screws, insuring that the screws pass through the holes in the ring terminals. Secure the PT Wires by fully tightening both cap screws in each Finger Cluster.

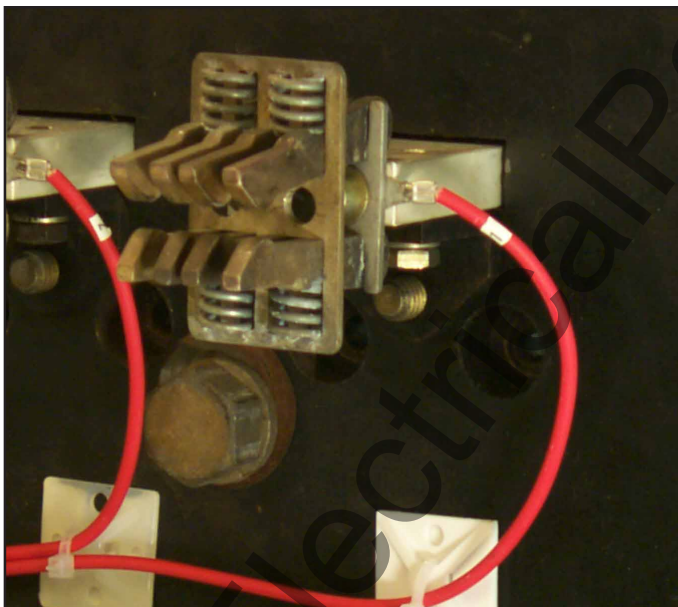

Fig. 34 PT Wires Connected to the Bottom Breaker Stabs.

- D. Use the self-adhesive mounting pads and wire ties supplied to secure the PT Wires to the Breaker Backplate.

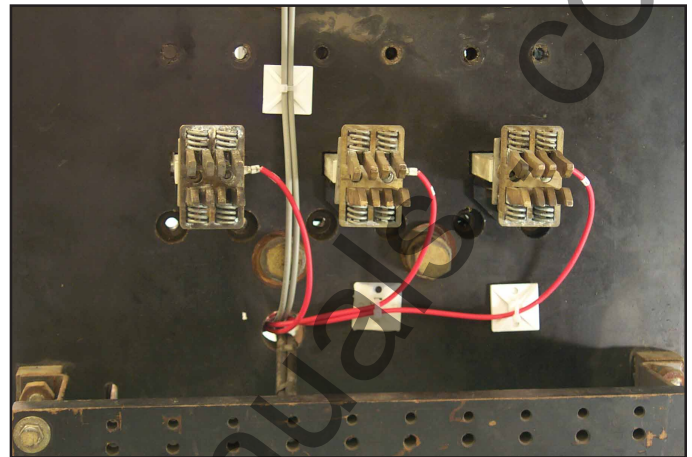

Fig. 35 PT Wires Secured to the Breaker Backplate.

For Kits Supplied with a Breaker Mounted CPT Only.

NOTE: The power convention of Circuit Breakers is normally Top to Bottom, meaning the Top Breaker Stabs (Load Terminals) are on the Line Side of the Breaker and the Bottom Breaker Stabs are on the Load Side.

The HV Wires from the CPT MUST BE ATTACHED to the Line Side of the Breaker. If it is determined that the power flow for the Breaker application is opposite the normal convention, the HV Wires must be attached to the Bottom Breaker Stabs. In the case of the Line Side being the Bottom Breaker Stabs, the cap screws that secure the bottom Finger Clusters to the bottom Breaker Stabs can be used for HV Wire attachment.

NOTE: The Line Side HV Wires are longer than necessary and are cut during the following steps. Before cutting the wires, be sure that sufficient length is left so that the HV Wire Fuses are accessible and that the connections can be made to the correct Load Terminals.

- E. Route the HV Line Side Wires up towards the Phase 1 and 2 or the Phase 2 and 3 top Finger Clusters. Cut each HV Wire to an appropriate length, strip .250" from each wire, then install a .250" ring terminal on each wire.
- F. Completely remove one (1) cap screw from each of the selected top Finger Clusters. Loosen the second cap screws to allow a gap between the Finger Clusters and top Breaker Stabs. Slide the HV Wire ring terminals between the Finger Clusters and the top Breaker Stabs as shown.

Insert the cap screws, insuring that the screws pass through the holes in the ring terminals. Secure the HV Wires by fully tightening both cap screws in each Finger Cluster.

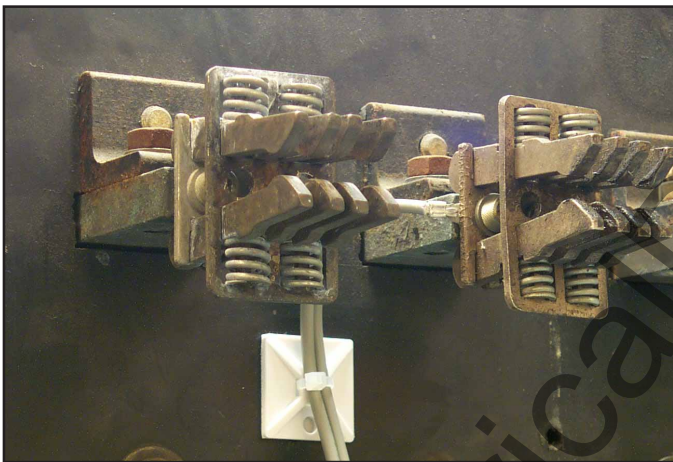

Fig. 36 HV Wires Connected to the Top Breaker Stabs.

- G. Use the self-adhesive mounting pads and wire ties supplied to secure the HV Wires to the Breaker Backplate.

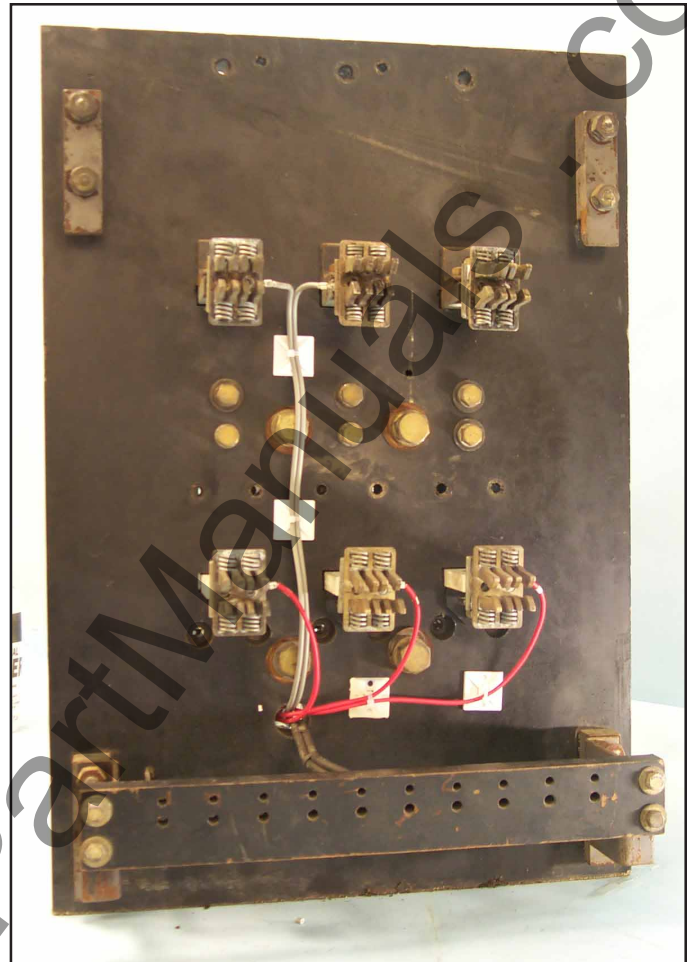

Fig. 37 HV Wires Secured to the Breaker Backplate.

N. Install the appropriate CPT Voltage Label in a clearly visible location on the Breaker Face Plate.



Fig. 38 CPT Voltage Labels Supplied with the CPT Kit.

STEP 8: INSTALLING THE TRIP FINGER AND DTA ASSEMBLY

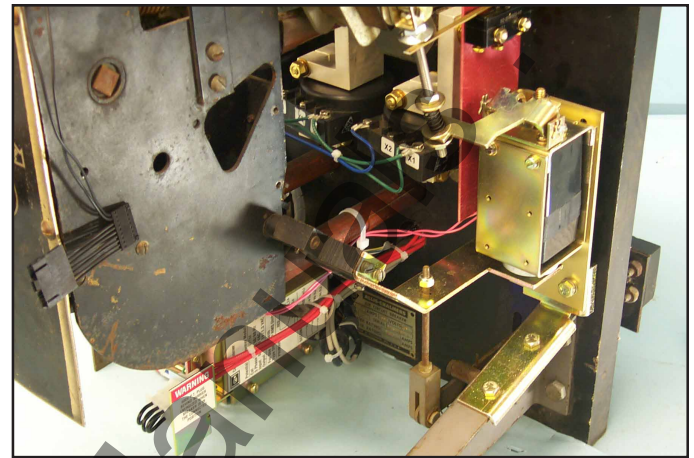

Fig. 39 Overview: Trip Finger and DTA Assembly Installed in the Breaker.

A. Using Drilling Plan "B", drill two (2) .281" diameter holes in the right front Breaker Foot.

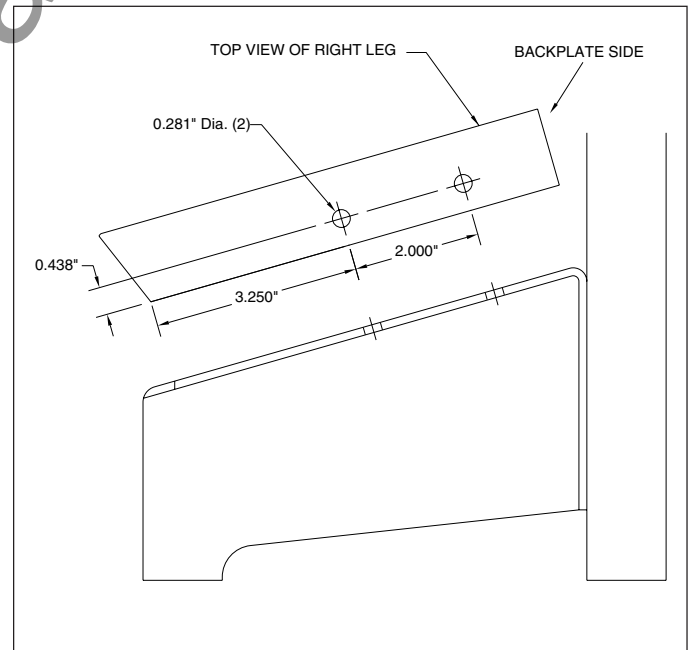

Fig. 40 Drilling Plan "B".

- B. Insert the Interlock Mechanism Rod through the hole in the Trip Finger as shown. Align the Trip Finger with the existing holes in the Breaker Trip Bar as shown. Secure the Trip Finger to the Breaker Trip Bar using the original mounting hardware removed in Step 2-H. Insure that the top edge of the Trip Finger is parallel with the top surface of the Breaker Trip Bar.

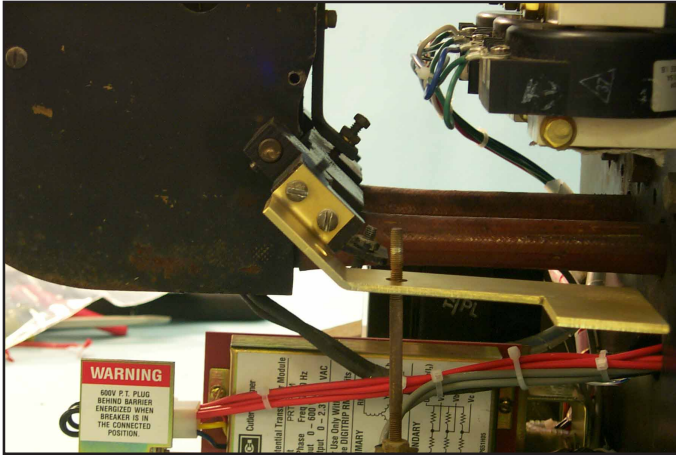

Fig. 41 Trip Finger Mounted to the Breaker Trip Bar.

- C. Install the (1) .164-32 Nylok nut supplied on the Interlock Mechanism Rod. Reset the gap between the bottom of the nut and the top surface of the Trip Finger. Refer to the specification recorded in Step 2-A to insure that the Interlock Mechanism has been reset correctly.

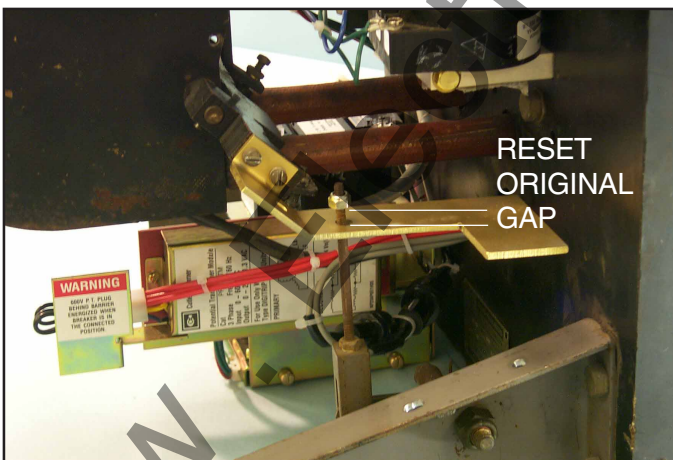

Fig. 42 Resetting the Interlock Mechanism.

- D. Align the DTA Mounting Bracket with the holes drilled in the right front Breaker Foot in Step 8-A, as shown. Secure the DTA Mounting Bracket to the Breaker Foot using the (2) .250-20 × .375" bolts, (2) flat washers, (2) lock washers, and (2) nuts supplied.

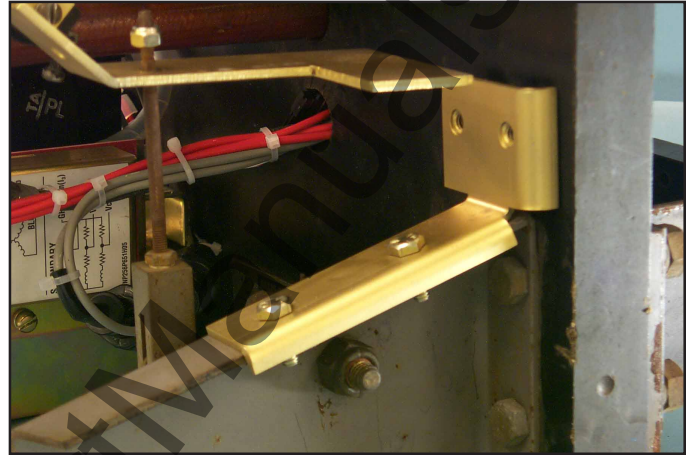

Fig. 43 DTA Mounting Bracket Installed on the Right Breaker Foot.

- E. For Kits Supplied with an Auxiliary Switch Only: Cut 2.00" from the end of the Microswitch Arm. Align the Microswitch with the holes in the DTA Insulation Barrier as shown. Secure the Microswitch to the DTA Insulation Barrier using the (2) .138-32 × 1.00" nylon screws, (2) flat washers, (2) lock washers, and (2) nuts supplied. Note that the nylon screws are inserted through the Insulation Barrier first, then through the Microswitch.

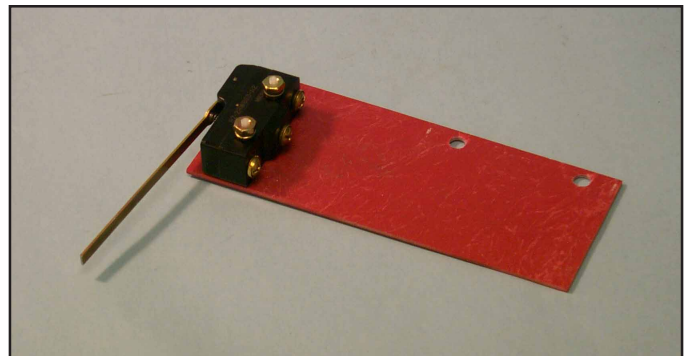

Fig. 44 Microswitch Switch Mounted to the DTA Insulation Barrier.

For All Kits.

- F. Align the DTA Insulation Barrier with the existing holes in the DTA Assembly as shown. Secure the Insulation Barrier to the DTA Assembly using the (2) .190-32 × .625" nylon screws and (2) flat washers supplied. Care should be taken not to over tighten the nylon screws and strip the threads.

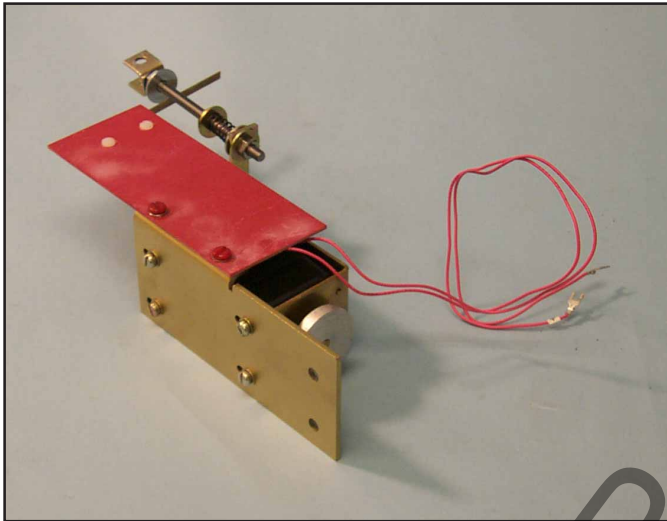

Fig. 45 DTA Insulation Barrier Mounted to the DTA Assembly.

- G. Align the DTA Assembly with the holes in the DTA Mounting Bracket as shown. Apply Loc-Tite® 243 to the threads then secure the DTA Assembly to the DTA Mounting Bracket using the (2) .250-20 × .750" bolts and (2) lock washers supplied. Insure that the right side of the DTA Assembly is parallel with the right side of the Breaker Backplate.

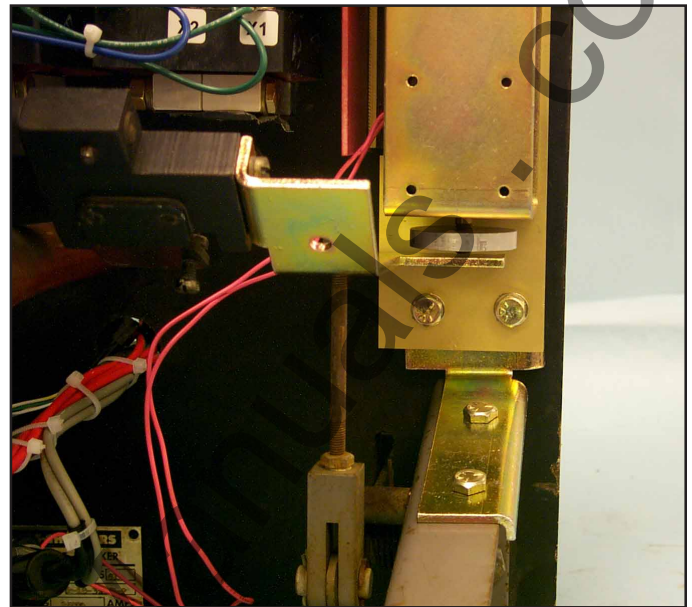

Fig. 46 DTA Assembly Mounted to the DTA Mounting Bracket.

- H. Align the "U" Bracket on the DTA Reset Rod with the existing hole in the right side of the Breaker Throw Bar. Apply Loc-Tite® 243 to the threads then secure the Rest Rod to the Breaker Throw Bar, as shown, using the (1) .250-20 × 2.00" bolt and (1) extra wide flat washer (1.00") supplied. Note that the "extra wide" flat washer must be placed between the end of the Breaker Throw Bar and the left side on the "U" Bracket. Also note that the mounting hardware must not be over tightened. The Reset Rod must be free to pivot on the mounting bolt.

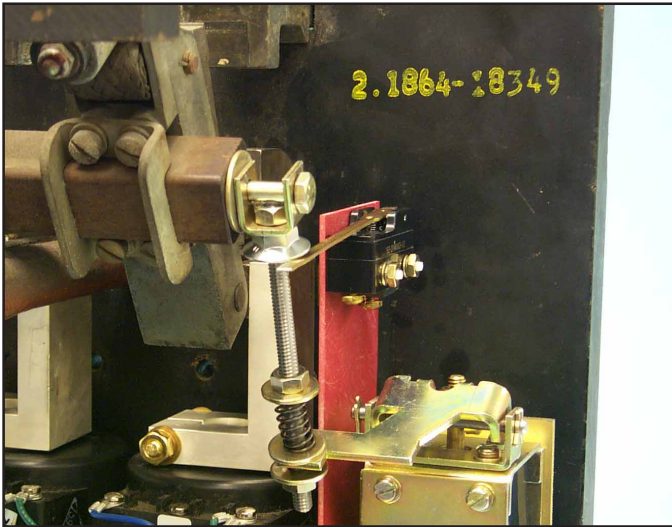

Fig. 47 Reset Rod Connected to the Breaker Throw Bar.

For Kits Supplied with an Auxiliary Switch Only:
Insure that the Auxiliary Switch Arm rides below the flange nut on the Reset Rod.

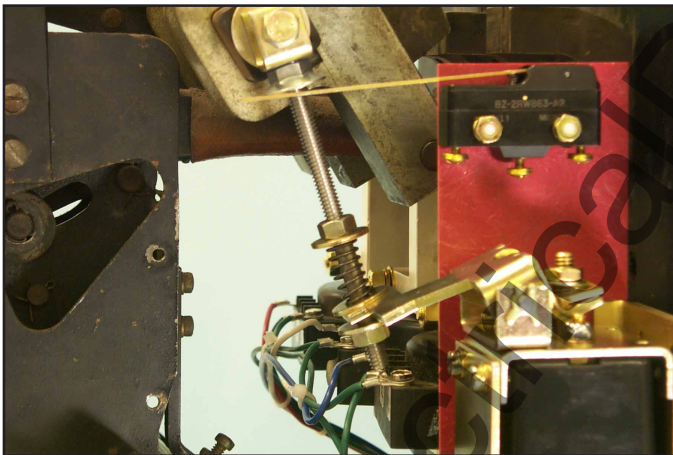

Fig. 48 Correct Orientation of the Auxiliary Switch Arm.

- I. Route the DTA Wires through the Breaker towards the Aux. CT Module. Secure the DTA Wires to the bottom right standoff using (1) nylon wire tie supplied to keep them clear of any moving components within the Breaker.

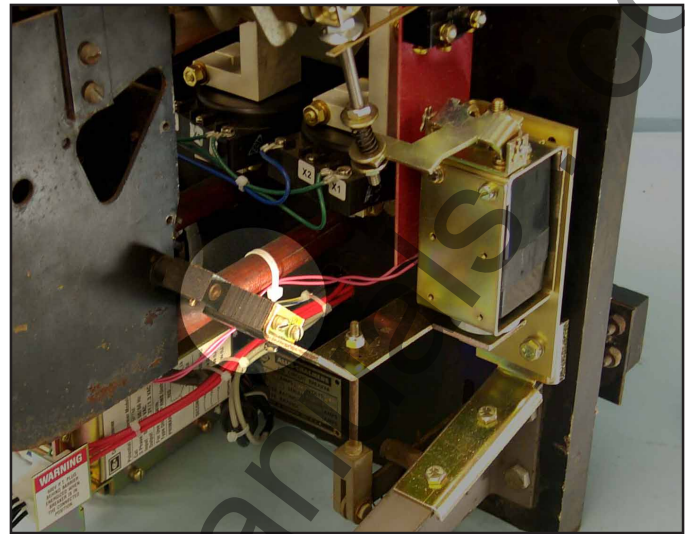

Fig. 49 DTA Wires Secured to the Bottom Right Standoff.

- J. Connect the “+” DTA Wire to the “OP” terminal of the Aux. CT Module Terminal Block and the unmarked wire to the “ON” terminal. Use the nylon wire ties supplied to secure the DTA Wires to the Sensor Harness.

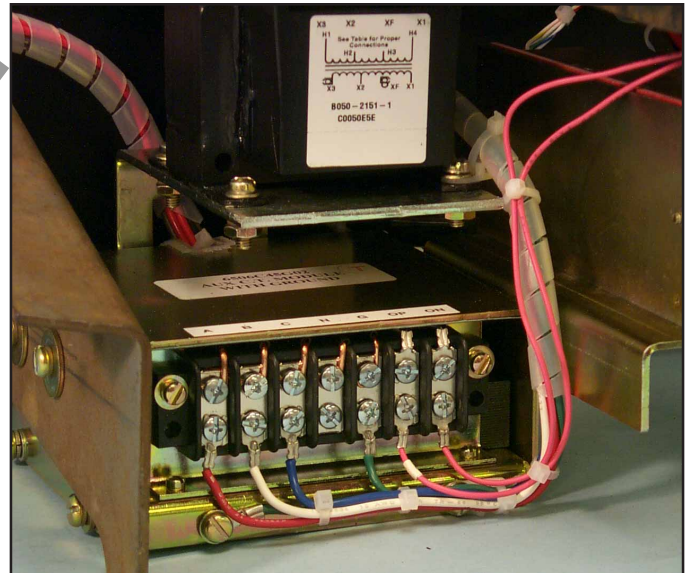

Fig. 50 DTA Wires Connected to the Aux. CT Module Terminal Block.

- K. Back-off the middle nut on the DTA Reset Shaft. Apply Loc-Tite® 243 to the threads of the Reset Shaft. Adjust the middle nut on the Reset Shaft until a cage height of between 0.656" and 0.687" is achieved.

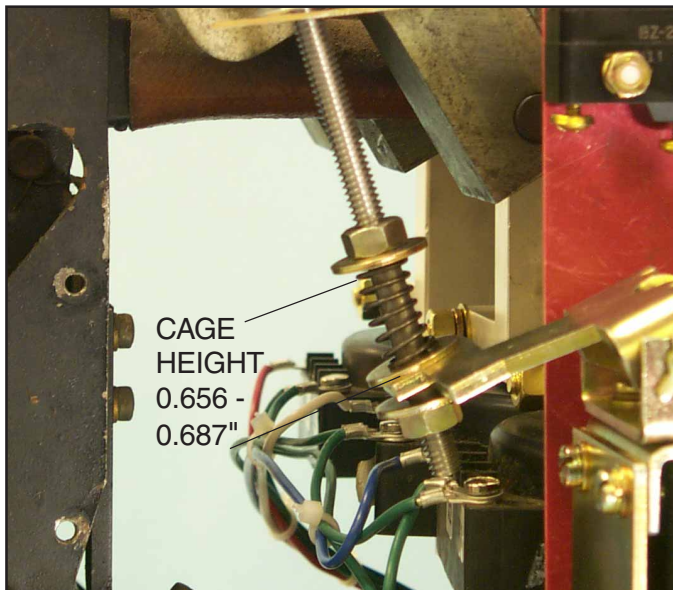

Fig. 51 Proper Cage Height Adjustment.

- L. Back-off the aluminum DTA Trip Disk. Apply Loc-Tite® 243 to the threads of the DTA Shaft. Turn the DTA Trip Disk until a gap of 0.110" to 0.130" is achieved between the bottom surface top of the Trip Disk and the top surface of the Trip Finger.

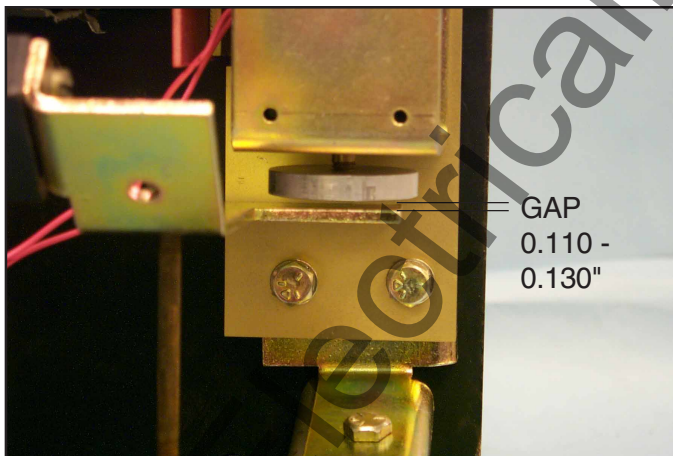

Fig. 52 Proper Air Gap Adjustment.

STEP 9: INSTALLING THE TRIP UNIT

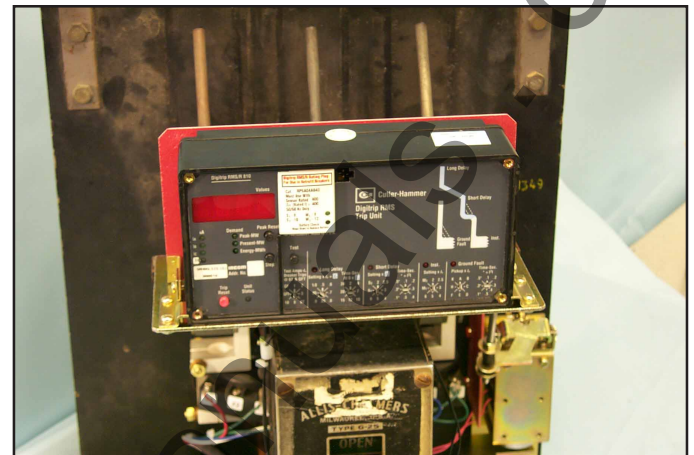

Fig. 53 Overview: Trip Unit Installed on the Breaker.

- A. Align the Trip Unit Insulation Barrier Mounting Brackets with the existing holes in the Insulation Barrier as shown. Secure the mounting brackets to the Insulation Barrier using the (4) .112-40 x .250" screws, (4) flat washers, and (4) lock washers supplied.
- B. Align the right and left Trip Unit Support Clips with the existing holes in the Insulation Barrier Mounting Brackets as shown. Secure the Support Clips to the Insulation Plate Mounting Brackets using the (2) .164-32 x .250" screws and (2) lock washers supplied.

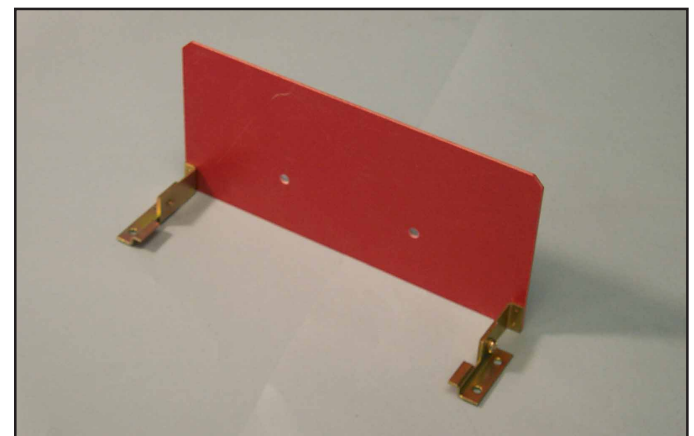

Fig. 54 Mounting Brackets and Trip Unit Support Clips Mounted to the Insulation Barrier.

- C. Align the Trip Unit with the existing holes in the Trip Unit Mounting Plate as shown. Secure the Trip Unit to the Mounting Plate using the (2) .190-32 x 4.00" screws, (2) lock washers, (2) flat washers, and (2) spacers supplied. Note that the brass spacers are positioned between the Mounting Plate and the bottom rear of the Trip Unit. Do not fully tighten the screws at this time.

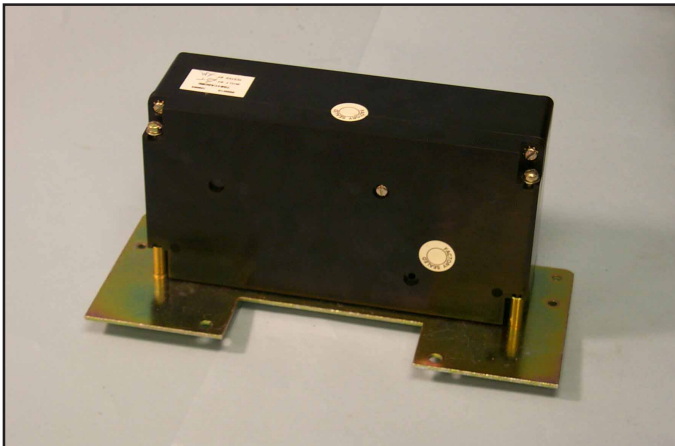

Fig. 55 Trip Unit Installed on the Trip Unit Mounting Plate.

- D. Align the Trip Unit Insulation Barrier Assembly with the holes in the Trip Unit Mounting Plate. Note that the Trip Unit Support Clips "pinch" in the slots on the sides of the Trip Unit as shown. Secure the Insulation Barrier Assembly to the Trip Unit Mounting Plate using the (4) .164-32 x .375" screws, (4) lock washers, (4) nuts, and (1) Panduit tie mount supplied. Note that the Panduit tie mount is installed on the bottom right surface of the Trip Unit Mounting Plate and held in place by the rear hardware securing the right Support Clip.

Secure the Trip Unit by tightening the 4.00" screws installed in Step 9-C.



Fig. 56 Trip Unit Insulation Barrier Assembly Mounted to the Trip Unit and Mounting Plate.

- E. Remove and scrap the hardware securing the top of the Breaker Center Mechanism Mounting Brackets to the Arc Chute Retaining Bar. Align the holes in the Trip Unit Assembly with the holes from which the hardware was just removed. Secure the Trip Unit Assembly to the Arc Chute Retaining Bar using the (2) .250-20 x 1.75" bolts, (2) flat washers, (2) lock washers, and (2) nuts supplied.

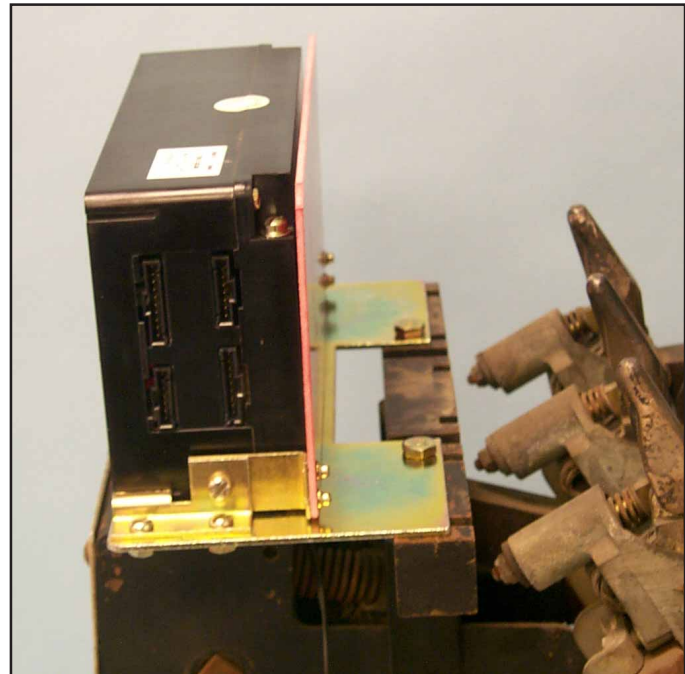

Fig. 57 Trip Unit Assembly Mounted on the Breaker.

- E. Remove the Trip Unit Cover and install the Rating Plug supplied with the Retrofit Kit. Reinstall the Cover.
- F. Install the Digitrip Retrofit Label on the top of the Trip Unit.

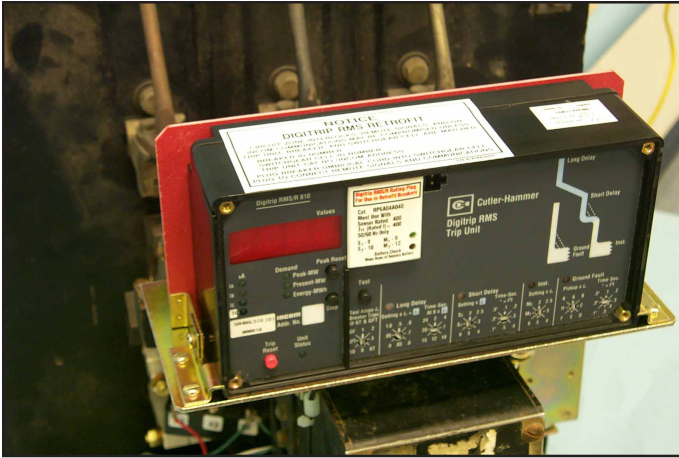

Fig. 58 Rating Plug and Digitrip Retrofit Label Installed.

STEP 10: INSTALLING THE EXTERNAL HARNESS AND FINAL WIRING

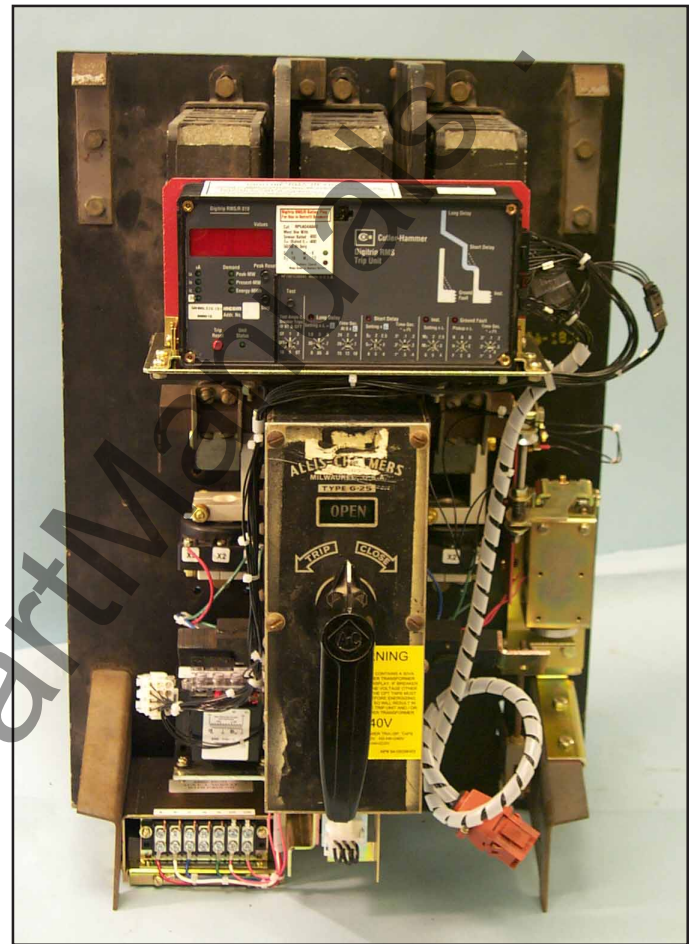

Fig. 59 Overview: External Harness Installed on the Breaker.

- A. Connect the Aux. CT Harness to the pigtail on the Aux. CT Module. Route the Aux. CT Harness up along the left side of the Breaker Center Mechanism, then across the top of the Center Mechanism to the right side of the Trip Unit. Plug the connector from the Aux. CT Harness into its receptacle in the Trip Unit.

Using the existing stud, the (1) .138-32 nut, (1) flat washers, (1) lock washer, and (1) cable clamp near the bottom, plus the (1) .164-32 x .500" screw, (1) flat washers, (1) lock washer, (1) nut, and (1) cable clamp near the top, secure the Aux. CT Harness to the right side of the Breaker Center Mechanism.

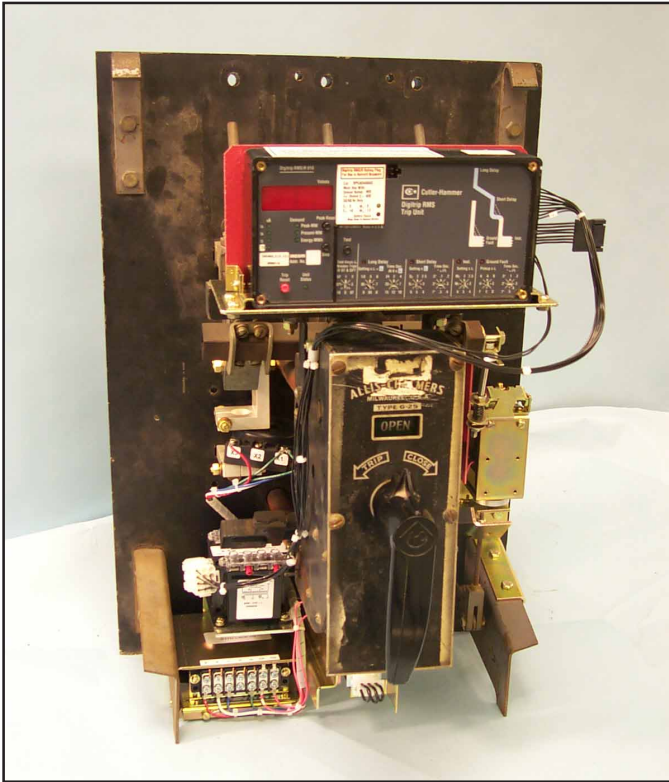

Fig. 60 Connection and Routing of the Aux. CT Harness.

B. Connect the External Harness to the Trip Unit.

NOTE: For 510 Basic Kits, the External Harness is the shorting plug pictured below. It is to be plugged into the right side of the Trip Unit.

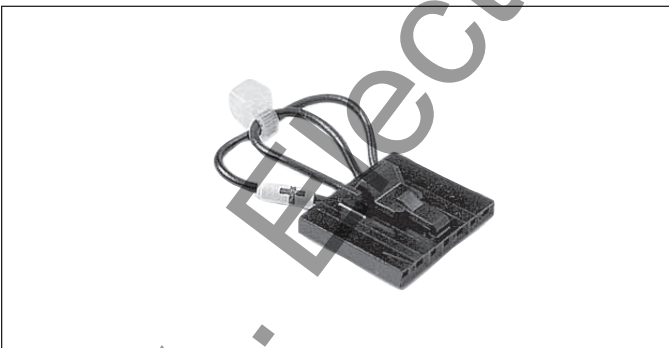

Fig. 61 510 Basic Kit External Harness Shorting Plug.

C. For Kits Supplied with a PT Module Only:
Connect the PT Extension Harness to the plug on the PT Module. Route the PT Extension Harness up along the left side of the Breaker Center Mechanism, then across the top of the Center Mechanism to the right side of the Trip Unit. Plug the connector from the PT Extension Harness into its receptacle on the External Harness. Use the wire ties supplied to secure the PT Extension Harness to the Aux. CT Harness.

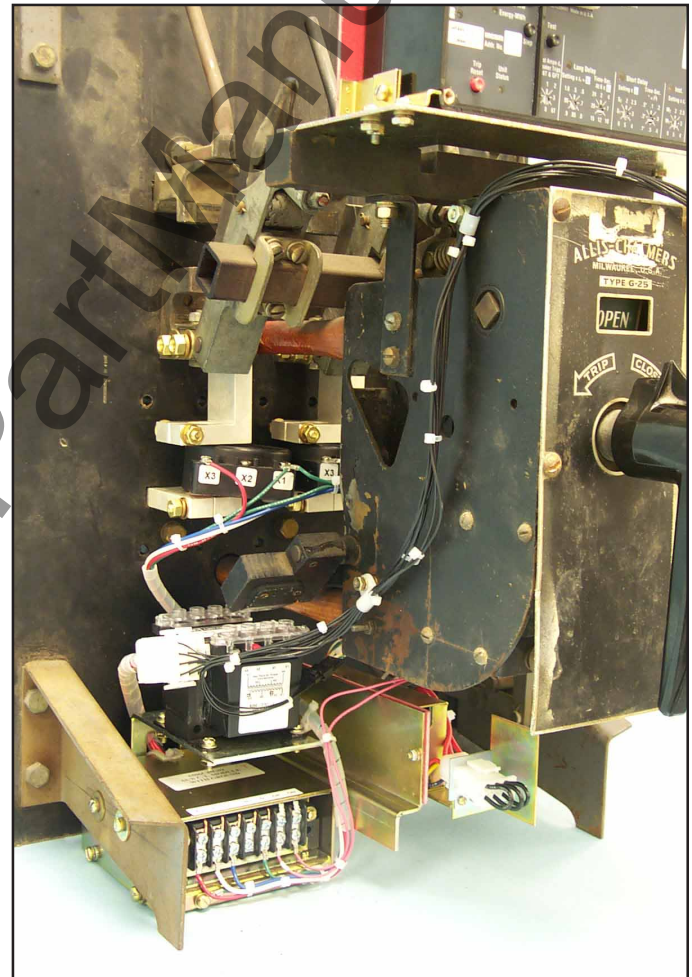

Fig. 62 Routing of the PT Extension Harness.

D. For Kits Supplied with an Auxiliary Switch Only:
Route the two (2) wires (with ring terminals) from the External Harness, down through the Breaker to the Auxiliary Switch. Connect one (1) wire to the normally "Open" terminal and the other wire to the "Common" terminal of the Auxiliary Switch.

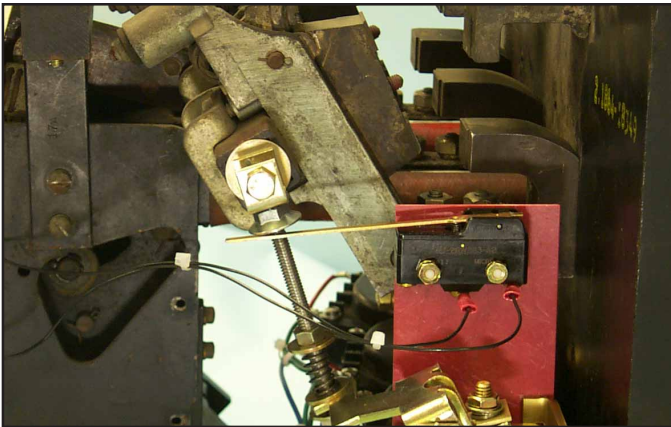

Fig. 63 External Harness Wires Connected to the Auxiliary Switch.

- E. For Kits Supplied with a Breaker Mounted CPT Only: Route the CPT Harness up along the left side of the Breaker Center Mechanism, then across the top of the Center Mechanism to the right side of the Trip Unit. Remove the External Harness plug installed in the bottom rear socket of the Trip Unit. Insert the black plug of the CPT Harness into the same receptacle in the Trip Unit. Reinsert the External Harness Plug just removed into the female receptacle on the CPT Harness. Use the wire ties supplied to secure the CPT Harness to the Aux. CT Harness.



Fig. 64 External Harness Connections at the Trip Unit.

- F. Using the (1) nylon wire tie supplied, secure the External Harness, Aux. CT Harness, and the PT Extension and CPT Harnesses if applicable to the Panduit tie mount on the right side of the Trip Unit Mounting Plate.

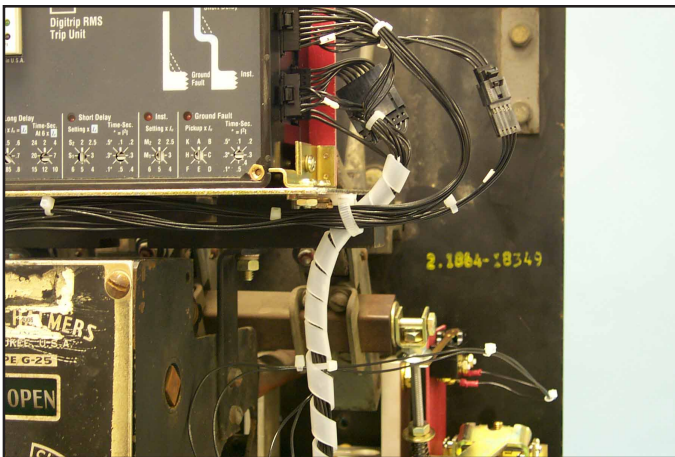

Fig. 65 Harness Secured to the Trip Unit Mounting Plate.

- G. Reinstall the Arc Chutes removed in Step 2-E using the original mounting hardware.
- H. Reinstall the lower Phase Barriers removed in Step 2-F using the original mounting hardware. When reinstalling the lower Phase Barriers, insure that none of the new harnesses or wires are “pinched” by the Phase Barriers.

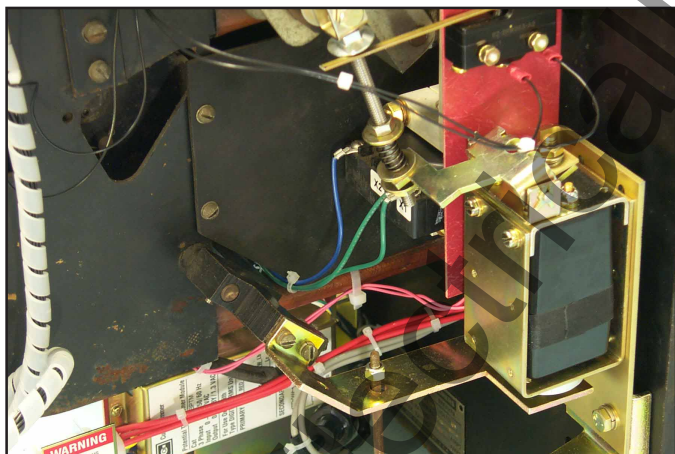

Fig. 66 Wires and Harnesses Routed Around the Lower Phase Barriers.

- I. Reinstall the top Phase Barriers removed in Step 2-D using the original mounting hardware.
- J. Use the self-adhesive mounting pads and wire ties supplied to dress all wires and harnesses to keep them away from any moving parts within the Breaker.

STEP 11: TESTING THE BREAKER

- A. Measure the force necessary to trip the Breaker at where the Trip Finger impacts the DTA Adjusting Disk. The force necessary to trip the Breaker **MUST NOT EXCEED 3 lbs.**
- B. The Retrofit must be tested using primary injection. Refer to Section 8 of the Instructions for the *Application of Digitrip RMS Retrofit Kits on Power Circuit Breakers* (Publication AD 33-855-4, September 2001), supplied with the Retrofit Kit, for detailed testing procedures and specifications. For test information specific to the Trip Unit, refer to the IL publication supplied with the Retrofit Kit (see the Pick List for the IL number).
- C. While Section 8 of the *Instructions for the Application of Digitrip RMS Retrofit Kits on Power Circuit Breakers* provides the information necessary for testing the Breaker, please keep the following notes in mind when reviewing other sections of the publication.



CAUTION

WHEN ALL TESTING IS COMPLETE, THE TRIP UNIT MUST BE RESET. FAILURE TO DO SO MAY CAUSE THE BATTERY IN THE RATING PLUG TO RUN DOWN.

NOTES:

1. *For All Kits Other Than 510 Basic:* If testing the Breaker with Short Delay or Ground Fault functions, be sure to either plug in the Cell Harness Assembly or use the Zone Interlock Shorting Plug. Failure to do so may result in shorter than expected trip times.
2. *For 810 and 910 Kits Only:* Without any power applied to the system (neither the 120 volt power supply nor the Aux. Power Module connected), plug the External Harness into the Cell Harness and check the impedance between COM 1 and COM 2. The impedance should be between one (1) and three (3) ohms. If the impedance is not within this range, trace the wiring and examine each connection to assure its integrity.

Confirm that the PowerNet communication wiring is correct by following the procedures detailed in Section 7.4 of the Instructions for the Application of Digitrip RMS Retrofit Kits on Power Circuit Breakers. Note that for 810 and 910 Kits, the impedance between COM 1 and COM 2 should be between one (1) and three (3) ohms.

When testing is complete, disconnect the External Harness from the Cell Harness. Final External Harness connection will be performed later in the Retrofit Process.

STEP 12: MOUNTING THE CELL HARNESS

- A. The Cell Harness is to be mounted in the Breaker Cell. The connector end is to be mounted on the right side of the Cell, in a location suitable for connection with the External Harness. The Terminal Blocks can be mounted anywhere space is available in the Cell as long as connection to the External Harness can be made.
- B. Route the Cell Harness wiring to keep it away from any moving parts within the Cell Housing.

**STEP 13: INSTALLING THE RETROFITTED
BREAKER IN THE CELL**

 WARNING

DO NOT LEAVE THE BREAKER IN AN INTERMEDIATE POSITION IN THE SWITCHGEAR CELL. ALWAYS LEAVE IT IN THE CONNECTED, DISCONNECTED, OR (OPTIONAL) TEST POSITION. FAILURE TO DO SO COULD LEAD TO IMPROPER POSITIONING OF THE BREAKER AND FLASHOVER, CAUSING DEATH, SERIOUS PERSONAL INJURY, AND / OR PROPERTY DAMAGE.

NOTE: It is the responsibility of the Retrofitter to insure proper Breaker / Cell fit. When racking the Breaker into the Connected position, the Retrofitter **MUST FOLLOW BOTH** the manufacturer's instructions and the customer's safety standards and procedures for racking a Breaker into the Connected position.

- A. With the Breaker in the Open position and the springs discharged, slowly rack the Breaker into the Connected position, making sure there is no interference or binding. The Breaker should rack smoothly and without mechanical interference between any Breaker and Cell parts. The Retrofitter will feel some resistance when the primary fingers connect onto the stabs of the Cell. This is normal.

However, if any unusual resistance is detected that could be abnormal interference between the Breaker and Cell parts, stop immediately and move the Breaker out of the Connected position. Examine what is causing the interference and correct the situation.

Digitrip Retrofit Kit Installation Components for Allis-Chalmers G-25 Breaker RMS/R Retrofits

| Step | Description | | Qty. | Comment |
|---------------------------------|---|------------|------|---------------|
| Step 3 | Sensor | 4A35743H01 | 3 | |
| | Sensor Mounting Parts | 9A10104G05 | 1 | |
| | Copper Adapter Top | | 3 | |
| | Copper Adapter Bottom | | 3 | |
| | Copper Adapter Cylinder | | 3 | |
| | Sensor Harness | | 1 | |
| | .313-18 × 2.00 Lng. Screw Brass F. H. | | 6 | |
| | .313 Flat Washer Brass | | 6 | |
| | .313 Lock Washer Bronze | | 6 | |
| | .313-18 Jam Nut Hex Brass | | 6 | |
| | .250-20 × 2.00 Lng. Bolt Brass | | 6 | |
| | .250-20 × .750 Lng. Bolt Brass | | 6 | |
| | .250 Flat Washer Brass | | 12 | |
| | .250 Lock Washer Bronze | | 12 | |
| | .250-20 Nut Hex Brass | | 6 | |
| | .190-16 × .500 Lng. Screw Pan T. C. | | 2 | |
| | .190 Flat Washer Stl. | | 2 | |
| | .190 Lock Washer Stl. | | 2 | |
| | Wire Tie Nylon | | 10 | |
| Cable Mount - Panduit | | 2 | | |
| Step 4 | Copper Adapter Bottom | | 3 | } From Step 3 |
| | Copper Adapter Cylinder | | 3 | |
| | Sensor | | 3 | |
| | Sensor Harness | | 1 | |
| | .250-20 × 2.00 Lng. Bolt Brass | | 3 | |
| | .250-20 × .750 Lng. Bolt Brass | | 6 | |
| | .250 Flat Washer Brass | | 6 | |
| | .250 Lock Washer Bronze | | 9 | |
| .250-20 Nut Hex Brass | | 3 | | |
| Step 5 | Aux. CT Module | 6506C454G | 1 | |
| | Aux. CT Module Mounting Parts | 9A10104G07 | 1 | |
| | .190-16 × .500 Lng. Screw T. C. | | 4 | |
| | .190 Flat Washer Stl. Extra Wide (.750) | | 2 | |
| | .190 Flat Washer Stl. Wide | | 1 | |
| | .190 Lock Washer Stl. | | 4 | |
| | PT Module | 6502C82G01 | 1 | } Comm. Only |
| | Ring Terminal (.190, .250, .312, .375, .500 -Each Size) | | 3 | |
| | PT Module Mounting Parts | 9A10104G04 | 1 | |
| | PT Module Mounting Bracket | | 1 | |
| | Insulation Barrier | | 1 | |
| | .190-16 × .500 Lng. Screw Pan T. C. | | 2 | |
| | .190 Flat Washer Stl. | | 2 | |
| .190 Lock Washer Stl. | | 2 | | |
| .138-32 × .500 Lng. Screw F. H. | | 2 | | |
| .138 Flat Washer Stl. | | 4 | | |

Digitrip Retrofit Kit Installation Components for Allis-Chalmers G-25 Breaker RMS/R Retrofits

| Step | Description | Qty. | Comment | |
|--------------------------------------|--|----------------------|---------|--------------------|
| Step 8 (cont.) | .250-20 × .375 Lng. Bolt Stl. | 2 | | |
| | .250 Flat Washer Stl. | 2 | | |
| | .250 Flat Washer Stl. Extra Wide (1.00") | 1 | | |
| | .250 Lock Washer Stl. | 4 | | |
| | .250-20 Nut Hex Stl. | 2 | | |
| | .190-32 × .625 Lng. Screw Pan Nylon | 2 | | |
| | .190 Flat Washer Stl. | 2 | | |
| | Loc-Tite® 243 | 2 | | |
| | Wire Tie Nylon | 6 | | |
| | Auxiliary Switch Kit | 9A10104G02 | 1 | } Comm. Only |
| | Microswitch | | 1 | |
| | .138-32 × 1.00 Lng. Screw Nylon | | 2 | |
| | .138 Flat Washer Stl. | | 2 | |
| | .138 Lock Washer Stl. | | 2 | |
| | Step 9 | .138-32 Nut Hex Stl. | 2 | |
| Trip Unit | | See Pick List | 1 | |
| Rating Plug | | See Pick List | 1 | |
| Trip Unit Mounting Parts | | 9A10104G06 | 1 | |
| Trip Unit Mounting Plate | | | 1 | |
| Insulation Barrier | | | 1 | |
| Support Clip R. H. | | | 1 | |
| Support Clip L. H. | | | 1 | |
| Insulation Barrier Mounting Bracket | | | 2 | |
| .250-20 × 1.75 Lng. Bolt Stl. | | | 2 | |
| .250 Flat Washer Stl. | | | 2 | |
| .250 Lock Washer Stl. | | | 2 | |
| .250-20 Nut Hex Stl. | | | 2 | |
| .190-32 × 4.00 Lng. Screw Fil. | | | 2 | |
| .190 Flat Washer Stl. | | | 2 | |
| .190 Lock Washer Stl. | | | 2 | |
| .164-32 × .375 Lng. Screw Stl. P. H. | | | 4 | |
| .164-32 × .250 Lng. Screw Stl. P. H. | | | 2 | |
| .164 Lock Washer Stl. | | | 6 | |
| .164-32 Nut Hex Stl. | | | 4 | |
| .112-40 × .250 Lng. Screw Stl. Fil. | | | 4 | |
| .112 Flat Washer Stl. | | | 4 | |
| .112 Lock Washer Stl. | | | 4 | |
| Spacer Brass | | | 2 | |
| Label Digitrip Retrofit | | | 1 | |
| Cable Mount - Panduit | | 2 | | |
| Wire Tie Nylon | | 8 | | |
| Step 10 | External Harness | 6502C83G_ | 1 | } Except 510 Basic |
| | External Harness Mounting Parts | 9A10104G10 | 1 | |
| | .164-32 × .500 Lng. Screw Stl. P. H. | | 2 | |
| | .164 Flat Washer Stl. | | 2 | |

Digitrip Retrofit Kit Installation Components for Allis-Chalmers G-25 Breaker RMS/R Retrofits

| Step | Description | Qty. | Comment | |
|---------|-----------------------|---------------|---------|------------|
| Step 10 | .164 Lock Washer Stl. | 2 | | |
| (cont.) | .138 Flat Washer Stl. | 1 | | |
| | .138 Lock Washer Stl. | 1 | | |
| | .138-32 Nut Hex Stl. | 1 | | |
| | Cable Mount - Panduit | 2 | | |
| | Wire Tie Nylon | 4 | | |
| | Aux. CT Harness | 6502C84G02 | 1 | |
| | PT Extension Harness | 6502C85G01 | 1 | Comm. Only |
| Step 12 | Cell Harness | See Pick List | 1 | |

NOTE: Due to the wide variety of Breakers and the multiple functions of the Retrofit components, some excess hardware may remain when the Retrofit is complete.

Table 5 Torque Values for General Mounting and Screw Size Conversion

| Decimal Size (in) | Standard Size | Torque (in-lbs) | Torque (ft-lbs) |
|-------------------|---------------|-----------------|-----------------|
| .112 | 4-40 | 10 | 0.8 |
| .138 | 6-32 | 18 | 1.5 |
| .164 | 8-32 | 36 | 3.0 |
| .190 | 10-32 | 46 | 3.8 |
| .250 | 1/4-20 | 100 | 8.3 |
| .312 | 5/16-18 | 206 | 17.2 |
| .375 | 3/8-16 | 356 | 29.7 |
| .438 | 7/16-14 | 572 | 47.7 |
| .500 | 1/2-13 | 856 | 71.3 |

Table 6 Torque Values for Copper BUS Connectors

| Decimal Size (in) | Standard Size | Torque (in-lbs) | Torque (ft-lbs) |
|-------------------|---------------|-----------------|-----------------|
| .250 | 1/4-20 | 60 | 5 |
| .312 | 5/16-18 | 144 | 12 |
| .375 | 3/8-16 | 240 | 20 |
| .500 | 1/2-13 | 600 | 50 |



Fig. 67 Retrofit Components

- | | |
|-------------------------------|-------------------------|
| A. Sensors | I. Sensor Harness |
| B. Trip Unit | J. External Harness |
| C. Aux. CT Module | K. Cell Terminal Block |
| D. Direct Trip Actuator (DTA) | L. Aux. Switch |
| E. CPT Transformer | M. PT Module |
| F. Rating Plug | N. PT Extension Harness |
| G. HV Wires | O. Adapters |
| H. Aux. CT Harness | P. CPT Harness |

We wish to thank you for purchasing the Digitrip Retrofit System. Digitrip Retrofit Kits are designed and manufactured in America with pride. All the components are engineered to fit the existing Circuit Breaker with little or no modifications to the existing Breaker. However due to the wide variety and vintage of Breakers in use today, an occasional problem may arise. Please contact us with any questions, comments or concerns.

Phone: 1-800-937-5487 Fax. (724) 779-5899

The instructions for installation, testing, maintenance, or repair herein are provided for the use of the product in general commercial applications and may not be appropriate for use in nuclear applications. Additional instructions may be available upon specific request to replace, amend, or supplement these instructions to qualify them for use with the product in safety-related applications in a nuclear facility.

The information, recommendations, descriptions, and safety notations in this document are based on Cutler-Hammer's experience and judgement with respect to Retrofitting of Power Breakers. This information should not be considered to be all inclusive or covering all contingencies. If further information is required, Cutler-Hammer should be consulted.

NO WARRANTIES, EXPRESSED OR IMPLIED, INCLUDING WARRANTIES OF FITNESS FOR A PARTICULAR PURPOSE OR MERCHANTABILITY, OR WARRANTIES ARISING FROM COURSE OF DEALING OR USAGE OF TRADE, ARE MADE REGARDING THE INFORMATION, RECOMMENDATIONS AND DESCRIPTIONS CONTAINED HEREIN. In no event will Cutler-Hammer be responsible to the user in contract, in tort (including negligence), strict liability or otherwise, for any special, indirect, incidental, or consequential damage or loss whatsoever, including but not limited to damage to or loss of use of equipment, plant or power system, cost of capital, loss of profits or revenues, cost of replacement power, additional expenses in the use of existing power facilities, or claims against the user by its customers resulting from the use of the information, recommendations, and descriptions contained herein.

Cutler-Hammer

Pittsburgh, Pennsylvania U.S.A.

Publication No. I.L. 33-AG6-1
February 2002
Printed in U.S.A./TBG00054

EATON