



# Instructions for Digitrip Models 1150 and 1150i Trip Units for use only in Cutler-Hammer Magnum and Magnum DS Circuit Breakers

## Table of Contents

1.0	General Description of Digitrip Units .....	5	4.2.4	Aux RELAYS .....	24
1.1	Protection .....	5	4.2.5	ALARMS .....	24
1.2	Mode of Trip and Status Information .....	5	4.2.6	ACCessory BUS (Relays).....	25
1.3.1	Installation of the Trip Unit .....	5	4.2.7	TripLink .....	26
1.3.2	Rating Plug Installation .....	6	4.2.8	Setting TIME .....	27
1.3.3	Trip Unit/Rating Plug Removal .....	7	4.2.9	Selecting DISPLAYS .....	27
1.4	Wiring .....	7	4.2.10	GENERAL Settings .....	27
1.6	DT 1150 Power/Relay Module .....	7	4.3	View Settings (VIEW SET) .....	27
1.6.1	Auxiliary Power .....	7	4.3.1	Firmware Menu .....	27
1.6.2	Alarm Contacts .....	7	4.4	METER .....	27
1.7	Standards .....	8	4.5	HARMONIC Menu .....	27
2.0	General Description of Magnum Circuit Breakers .....	8	4.6	EventLOG .....	28
2.1	General .....	8	4.7	Power and Energy Parameters .....	28
2.2	Low-Energy Trip Actuator .....	9	4.8	Power Quality .....	28
2.3	Ground Fault Protection .....	9	4.8.1	Power Factor, THD and Crest Factor .....	28
2.3.1	General .....	9	4.8.2	Alarms .....	29
2.3.2	Residual Sensing .....	10	4.9	WAVEFORM CAPTURE Feature .....	29
2.3.3	Source Ground Sensing .....	10	4.9.1	Six Cycle Waveform Capture on Trip .....	29
2.3.4	Zero Sequence Sensing .....	10	4.9.2	One Cycle Waveform Capture .....	29
2.3.5	Multiple Source/Multiple Ground .....	10	5.0	Test Procedure .....	29
2.3.6	Ground Fault Settings .....	10	5.1	General .....	29
2.4	Current Sensors (Magnum Frames less than or equal to 3200A) .....	11	5.2	When to Test .....	30
2.5	Current Sensors (Magnum Frames greater than 3200A) .....	11	5.2.1	Self Testing .....	30
3.0	Principles of Operation .....	11	5.2.2	Functional Field Testing .....	31
3.1	General .....	11	5.3	Performance Testing for Ground Fault Trip Units ....	31
3.2	Trip and Operation Indicators .....	11	5.3.1	Code Requirements .....	31
3.2.1	Status LED .....	12	5.3.2	Standard Requirements .....	31
3.2.2	Alarm LED .....	12	5.3.3	General Test Instructions .....	31
3.2.3	Trip LED .....	12	6.0	Battery .....	32
3.3	Making Current Release .....	12	6.1	General .....	32
3.4	Zone Interlocking .....	12	6.2	Battery Test .....	32
3.5	PT Module .....	12	6.3	Battery Installation and Removal .....	32
4.0	Programming/View Digitrip 1150 .....	17	7.0	Frame Ratings (Sensor Ratings and Rating Plugs) .....	33
4.1	Main Menu .....	17	8.0	Record Keeping .....	34
4.1.0	Power Up Sequence .....	17	9.0	References .....	34
4.1.1	Pushbutton Definition .....	17	9.1	Magnum and Magnum DS Circuit Breakers .....	34
4.1.2	Blink Mode .....	20	9.2	Time-Current Curves .....	34
4.1.3	Programming/Viewing Screens .....	20	Appendix A	Zone Interlocking Example .....	39
4.1.4	Reset Pushbutton Operation (After Trip) .....	20	Appendix B	Troubleshooting Guide .....	40
4.2	Program Settings PGM SET .....	20	Appendix C	Typical Breaker Master Connection Diagram .....	42
4.2.1	Curve Type Selection and Pickup/Time Settings .....	20	Appendix D	Display Menu Diagrams .....	43
4.2.2	AMP UNBALANCE, PHASE LOSS .....	23	Appendix E	Display Abbreviations .....	66
4.2.3	INCOM .....	24	Appendix F	Digitrip Settings Descriptions .....	68
			Appendix G	Auxiliary Relays .....	71
			Appendix H	Accessory Bus Digital Output Modules .....	72

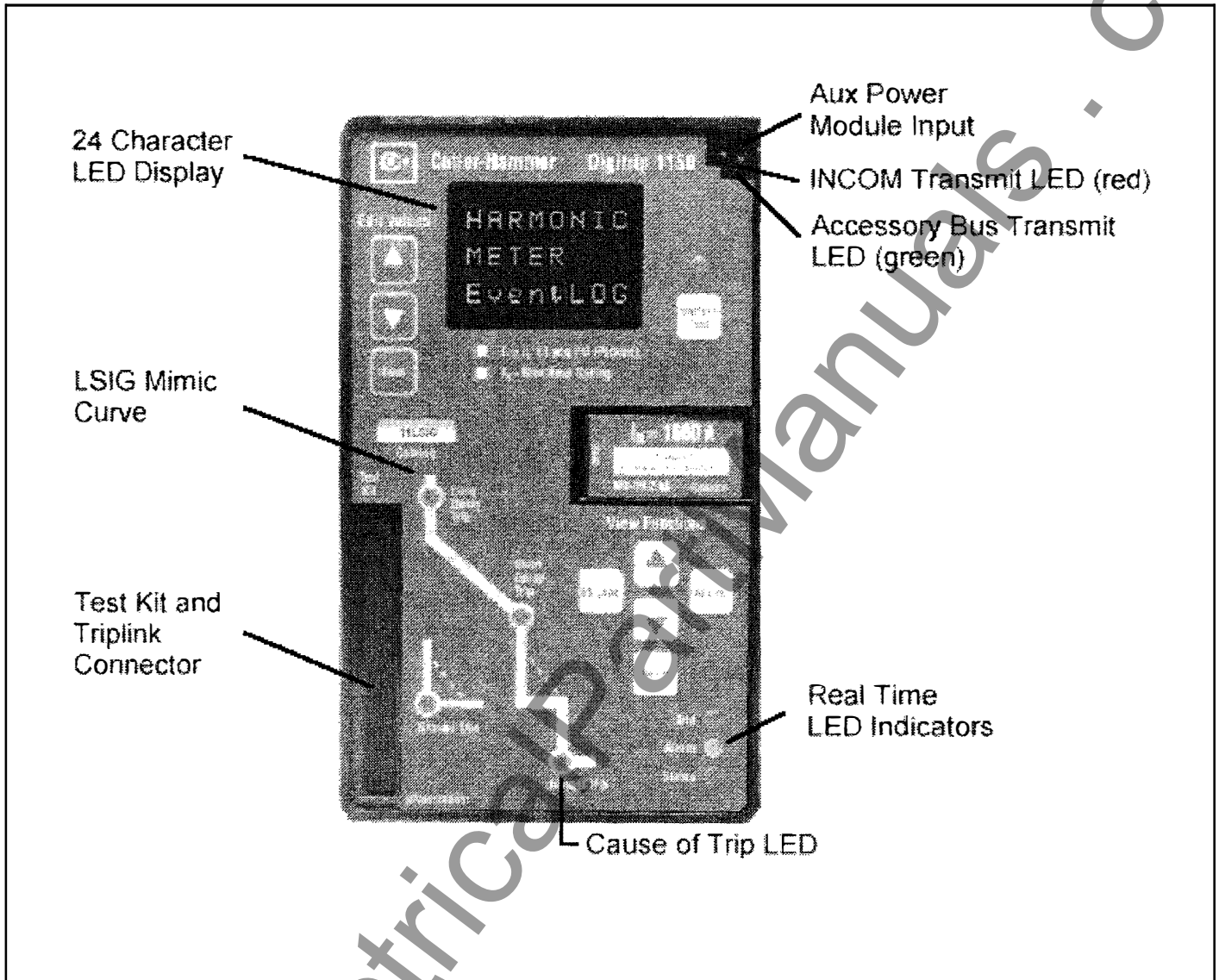

Figure 1.1 Digitrip 1150 Catalog # 11LSIG Trip Unit with Rating Plug

**⚠ WARNING**

**DO NOT ATTEMPT TO INSTALL OR PERFORM MAINTENANCE ON EQUIPMENT WHILE IT IS ENERGIZED. DEATH OR SEVERE PERSONAL INJURY CAN RESULT FROM CONTACT WITH ENERGIZED EQUIPMENT. ALWAYS VERIFY THAT NO VOLTAGE IS PRESENT BEFORE PROCEEDING. ALWAYS FOLLOW SAFETY PROCEDURES. CUTLER-HAMMER IS NOT LIABLE FOR THE MISAPPLICATION OR MISINSTALLATION OF ITS PRODUCTS.**

**⚠ WARNING**

**OBSERVE ALL RECOMMENDATIONS, NOTES, CAUTIONS, AND WARNINGS RELATING TO THE SAFETY OF PERSONNEL AND EQUIPMENT. OBSERVE AND COMPLY WITH ALL GENERAL AND LOCAL HEALTH AND SAFETY LAWS, CODES, AND PROCEDURES.**

**NOTE:** The recommendations and information contained herein are based on experience and judgement, but should not be considered to be all inclusive or to cover every application or circumstance which may arise.

Table 1.1a Protection Functions for Digitrip 1150/1150i Trip Units

Trip Unit Type		Digitrip 1150	Digitrip 1150i
Ampere Range		200A-5000A	200A-6300A
RMS Sensing		Yes	Yes
<b>Protection and Coordination</b>			
<b>Protection</b>	Ordering Options Catalog # Fixed Rating Plug ( $I_n$ ) OverTEMPerature TRIP Curve Type SLOPE	11LSI/11LSIG, 11LSIA Yes Yes LSI/LSIG, LSIA I2T, I4T IEEE <sup>5</sup>	11IEC/11IEC-EF Yes Yes LSI/LSIG I2T, I4T IEC <sup>5</sup>
<b>Long Delay Protection</b>	LONG delay Pick Up LONG delay TIME @ 6 x ( $I_n$ ) I2T LONG delay TIME @ 6 x ( $I_n$ ) I4T LONG delay thermal MEMORY	0.4-1.0 x ( $I_n$ ) 2-24 seconds 1-5 seconds Yes	0.4-1.0 x ( $I_n$ ) 2-24 seconds 1-5 seconds Yes
<b>Short Delay Protection</b>	SHORT delay Pick Up <sup>3</sup> SHORT delay TIME @ 8 x ( $I_n$ ) I2T <sup>4</sup> SHORT delay TIME FLAT SHORT delay TIME ZONE INTERLOCK	150-1000% x ( $I_n$ ) 0.10-0.50 s 0.10-0.50 s Yes	150-1000% x ( $I_n$ ) 0.10-0.50 s 0.10-0.50 s Yes
<b>Instantaneous Protection</b>	INSTAntaneous Pick Up <sup>3</sup> Off Setting Making Current Release	200-1000% x ( $I_n$ ) Yes Yes	200-1000% x ( $I_n$ ) Yes Yes
<b>Neutral Protection</b>	4 <sup>th</sup> Pole or External Neutral Trip	Yes-11LSI only (50%,100%)	Yes-11IEC only (50%,100%)
<b>Ground (Earth) Fault Protection</b>	GROUND fault option GROUND fault Pick Up Off Position GROUND fault delay @ .625 x ( $I_n$ ) I2T GROUND fault delay FLAT GROUND fault ZONE INTERLOCK GROUND fault memory	Yes 24-100% x ( $I_n$ ) <sup>1</sup> No 0.10-0.50 s 0.10-0.50 s Yes Yes	Yes 10-100% x ( $I_n$ ) Yes 0.10-0.50 s 0.10-0.50 s Yes Yes
<b>Phase Protection</b>			
AMP UNBALANCE		Yes	Yes
PHASE LOSS (current-based)		Yes	Yes
<b>System Diagnostics / Protection Related Alarms</b>			
Status/Long Pick Up LED		Yes	Yes
Cause of Trip LED's		Yes <sup>2</sup>	Yes <sup>2</sup>
HighLOAD ALARM		Yes	Yes
Long Delay Pick Up ALARM		Yes	Yes
GROUND ALARM		Yes-11LSIG	Yes-11IEC-EF
GROUND ALARM only - style		11LSIA	-
NEUTral AMPere ALARM		Yes	Yes
OPERation COUNT ALARM		Yes	Yes
<b>Auxiliary Relay Contacts (Programmable)</b>			
Block Close (1 contact)		Yes	Yes
ALARM/TRIP (2 contacts)		Yes	Yes

- Notes:
- ANSI/UL versions are limited to 1200 Amperes to comply with UL and NEC standards.
  - Four cause of trip LEDs indicate LONG, SHORT, INST or GROUND trip. Making Current Release and the separate High Instantaneous Module are indicated by the Instantaneous LED.
  - An additional setting is marked M1 where:
 

800 - 3200A Frame	M1 = 14 x $I_n$ for Plug Amps 200 through 1250A
	M1 = 12 x $I_n$ for Plug Amps 1600, 2000, 2500A
	M1 = 10 x $I_n$ for Plug Amps 3000, 3200A
4000 - 6300A Frame	M1 = 14 x $I_n$ for Plug Amps 2000, 2500A
	M1 = 12 x $I_n$ for Plug Amps 3200, 4000, 5000A (see Section 2.5)
	M1 = 10 x $I_n$ for Plug Amps 6300A
  - Only available when Long Time I2T is selected.
  - Phase protection with 3 response types.

Table 1.1b Metering Data for Digitrip 1150/1150i Trip Units

Current Metering	Units	Tolerance	Notes
IA, IB, IC, IN, IG	Amperes	±1% FS	Real time data, FS = In rating
IA, IB, IC (AVG)	Amperes		5 MINUTE AVERAGE
IN, IG (AVG)	Amperes		5 MINUTE AVERAGE
IA, IB, IC (Max)	Amperes		Group values held until Reset.
IN, IG (Max)	Amperes		Based on approximately 1 second
IA, IB, IC (Min)	Amperes		time interval
IN, IG (Min)	Amperes		
Voltage Metering			
VAB, VBC, VCA	Volts	±1% FS	FS (Full Scale) = 690 V
Power Metering			
Power	kW	±2% FS	Approximately 1 Second update
kVA	kVA	±2% FS	
kvar	kvar	±2% FS	
DEMAND kW	kW	±2% FS	LAST AVG - 5 MIN INTERVAL
DEMAND Max kW	kW	±2% FS	SLIDING or FIXED 15 MIN INTERVAL*
DEMAND kVA	kVA	±2% FS	LAST AVG - 5 MIN INTERVAL
DEMAND Max kVA	kVA	±2% FS	SLIDING or FIXED 15 MIN INTERVAL*
Energy Metering			
ENERGY kWh	kWh	±2% FS	
ENERGY Rev kWh	kWh	±2% FS	
KVAh	kVAh	±2% FS	
Metering Related Alarms			
kVA DEMAND ALARM	kVA	1 to 12500	LAST AVG - 5 min fixed interval
kW DEMAND ALARM	kW	1 to 12500	LAST AVG - 5 min fixed interval
Other			
kVAh PULSE INITIATE	kVAh	See section	INITIATE is an abbreviation for INITIATOR
kWh PULSE INITIATE	kWh	4.7	INITIATE is an abbreviation for INITIATOR

\* Only one of DEMAND Max kW or DEMAND Max kVA can be SLIDING INTERVAL

Table 1.1c Power Quality Data for Digitrip 1150/1150i Trip Units

Harmonic	Units	Notes
THD (Total Harmonic Distortion)		
THDA	0 to 99 percent	Phase A current
THDB	0 to 99 percent	Phase B current
THDC	0 to 99 percent	Phase C current
THDN	0 to 99 percent	Neutral current
Per Harmonic Data		Fundamental through 27 <sup>th</sup>
HARMON A	0 to 99 percent	Phase A current
HARMON B	0 to 99 percent	Phase B current
HARMON C	0 to 99 percent	Phase C current
HARMON N	0 to 99 percent	Phase N current
CF (Crest Factor)		
CFA	1.0 to 25.5	Phase A current
CFB	1.0 to 25.5	Phase B current
CFC	1.0 to 25.5	Phase C current
CFN	1.0 to 25.5	Phase N current
Power Factor / Frequency		
PF (Power Factor)	0 to 1.00	Located in METER menu, real time data
PF MIN	0 to 1.00	Value held until Reset
PF MAX	0 to 1.00	Value held until Reset
Hz (Frequency)	Hz	Located in METER menu
Power Quality Related Alarms (Programmable)		
LOW PF ALARM	50 to 95 percent	OFF setting available
THD ALARM	10 to 30 percent	OFF setting available

If you have any questions or need further information or instructions, please contact your local representative or the Customer Support Center at 1-800-356-1234.

## 1.0 GENERAL DESCRIPTION OF DIGITRIP TRIP UNITS

The Digitrip Trip Units are breaker subsystems that provide the protective functions of a circuit breaker. The trip unit is in a removable sealed housing, installed in the breaker, and can be replaced in the field by the end user.

This instruction book specifically covers the application of Digitrip Trip Units, as illustrated in Figure 1.1, installed in Magnum and Magnum DS Breakers. Throughout this Instructional Leaflet, the use of the term "Magnum Breakers" refers to both the Magnum and Magnum DS low-voltage, AC power circuit breakers.

The Magnum Digitrip line of trip units consists of the 1150 which conforms to UL standards, and model 1150*i* conforming to IEC standards. Throughout this Instructional Leaflet, the use of the term Digitrip 1150 trip units refers to both models unless otherwise stated. There are three possible styles of the DT 1150 (11LSI, 11LSIG, 11LSIA) and two styles of the DT 1150*i* (11IEC and 11IEC-EF).

The Digitrip 1150 trip units may be applied to either 50 or 60 Hz systems.

Digitrip DT1150 family of trip units incorporate two microprocessors in their design. One processor is devoted totally to the task of current protection functions. This processor provides true RMS current sensing for the proper coordination with the thermal characteristics of conductors and equipment. The Digitrip analyzes the secondary current signals from the circuit breaker current sensors and, when preset current levels and time delay settings are exceeded, sends an initiating trip signal to the Trip Actuator of the circuit breaker. The current sensors provide operating power to the trip unit. As current begins to flow through the breaker, the sensors generate a secondary current which powers the trip unit.

The second microprocessor provides the display, communications, metering, harmonic calculations, alarming and auxiliary relay functions. These additional features require that auxiliary power be provided to the circuit breaker.

### 1.1 Protection

Each Digitrip DT1150 Trip Unit is completely self-contained and requires no external control power to operate its basic over current protection functions. It operates from current signal levels derived through current sensors mounted in the circuit breaker. The types of protection available for each model are shown in Table 1.1.

The Digitrip 1150 family of trip units provides five phase and two ground (time-current) curve-shaping adjustments. To satisfy the protection needs of any specific installation, the exact selection of the available protection function is adjustable. The short delay and ground fault adjustments include either a FLAT or I<sup>2</sup>T response. A pictorial representation of the applicable time-current curves for the selected protection functions is provided, for user reference, on the face of the trip unit as shown in Figure 1.1.

**NOTE:** The Digitrip 1150 (11LSI style) and Digitrip 1150*i* (11IEC) are the two styles that can be used on 3-pole or 4-pole circuit breakers for the protection of the neutral circuit. For a 3-pole breaker an external sensor of the same rating as the phase sensor needs wired to the circuit breaker. Only these two styles can provide neutral protection, although all styles can provide neutral metering and alarming (one exception is that there is no metering for source or zero sequence Ground Fault application). These styles also have a protection setting called Neutral Ratio. The 100% setting is the default and is used when phase and neutral conductors are of the same ampacity. The 50% setting is for a half sized neutral conductor and essentially shifts the Long Time thermal curve to the left making it more sensitive. Refer to the National Electric Code (NEC) for the appropriate application for 4-pole breakers.

### 1.2 Mode of Trip and Status Information

On all DT1150 units, a green light emitting diode (LED), labeled Status, blinks approximately once each second to indicate that the trip unit is operating normally. This Status LED will blink at a faster rate if the Digitrip is in a pick-up, or overload, mode.

Red LEDs on the face of the 1150 family of trip units flash to indicate the cause, or trip mode, for an automatic trip operation (for example, ground fault, overload, or short circuit trip). A battery in the Digitrip unit maintains the trip indication until the Reset button is pushed. The battery is satisfactory if its LED lights green when the Battery Test button is pushed (see Section 6).

**NOTE:** The Digitrip 1150 family provides all protection functions regardless of the status of the battery. The battery is only needed to maintain the automatic trip indication when auxiliary power is not available.

### 1.3 Installation and Removal

#### 1.3.1 Installation of the Trip Unit

Align the Digitrip unit with the molded guide ears on the platform and spring clips of the Magnum Circuit Breaker. Before plugging into the black edge connector, align the

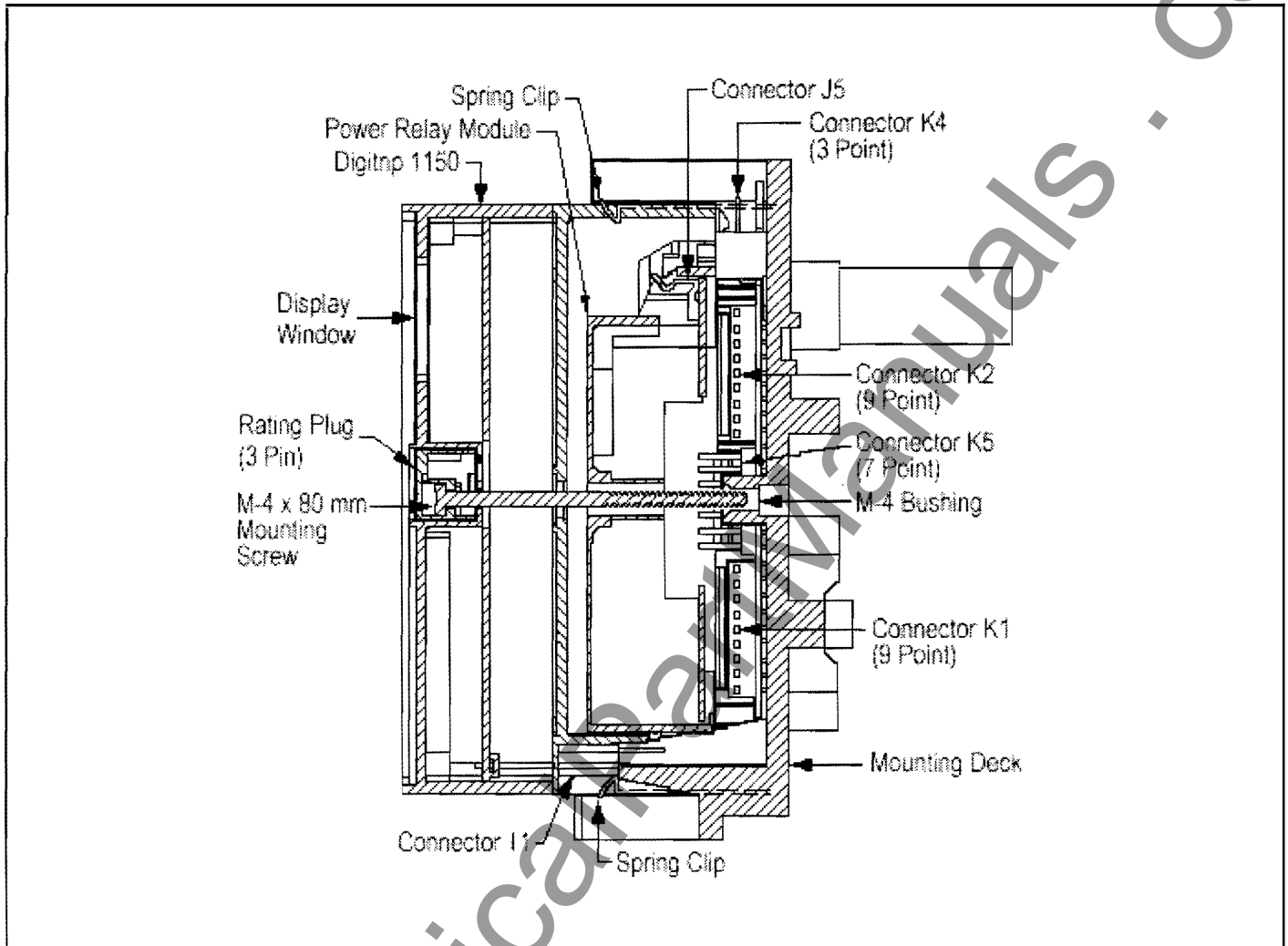

Figure 1.2 Installation of the Digitrip Unit into a Magnum Breaker (Side View)

long pins on the bottom of the Digitrip into the white, I1, connector. See Figure 1.2. Press the unit into breaker until the PC board edge engages into the connector and the spring clips engage over the Digitrip's housing.

### 1.3.2 Rating Plug Installation



#### WARNING

**DO NOT ENERGIZE THE MAGNUM BREAKER WITH THE DIGITRIP REMOVED OR DISCONNECTED FROM ITS CONNECTOR. DAMAGE TO INTERNAL CURRENT**

**TRANSFORMERS MAY OCCUR DUE TO AN OPEN CIRCUIT CONDITION.**



#### CAUTION

**IF A RATING PLUG IS NOT INSTALLED IN THE TRIP UNIT, THE UNIT WILL INITIATE A TRIP WHEN IT IS ENERGIZED. IN ADDITION THE INSTANTANEOUS LED WILL LIGHT ON A PLUG TRIP.**

Insert the rating plug into the cavity on the right-hand side of the trip unit. Align the three pins on the plug with the sockets in the cavity. The plug should fit with a slight insertion force.

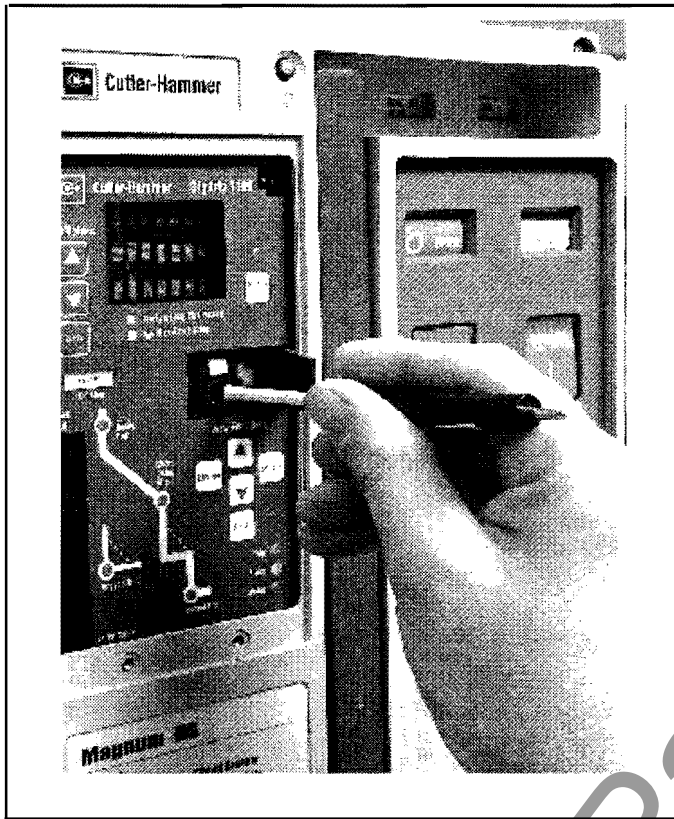

Figure 1.3 Installation of the Rating Plug and Mounting Screw

**! CAUTION**

**DO NOT FORCE THE RATING PLUG INTO THE CAVITY.**

Use a 1/8" (3 mm) wide screwdriver to tighten the M4 screw and secure the plug and the trip unit to the circuit breaker (see Figure 1.3). Close the rating plug door.

**! CAUTION**

**THE M4 SCREW SHOULD BE TIGHTENED ONLY UNTIL IT IS SNUG. DO NOT USE A LARGE SCREWDRIVER. A 1/8" (3 mm) WIDE SCREWDRIVER BLADE IS ADEQUATE.**

**1.3.3 Trip Unit/Rating Plug Removal**

To remove the rating plug from the trip unit, open the rating plug door. Use a 1/8" (3 mm) wide screwdriver to loosen the M4 screw. Pull the door to aid in releasing the rating plug from the unit.

To remove the trip unit from the circuit breaker, deflect the top and bottom spring clips to release the unit from the steel mounting plate. Pull the unit to disengage the trip unit's printed circuit board connectors J0 & I1 from the circuit breaker (see Figure 1.2 and Appendix C).

**1.4 Wiring**

The internal components of the breaker and their connection points to the secondary contacts, are shown in the breaker master connection diagram provided as Appendix C.

**1.5 Plexiglass Cover**

A clear, tamper-proof plexiglass door sits on the breaker cover. This door, if sealed, allows the settings to be viewed but not changed, except by authorized personnel. The plexiglass cover meets applicable tamper-proof requirements. The cover is held in place by two cover screws. Security is insured by the insertion of a standard meter seal through the holes in both of the cover retention screws. The plexiglass cover has an access cutout for the View Functions group of pushbuttons and the Battery Test pushbutton.

**1.6 DT 1150 Power/Relay Module**

The Power/Relay Module (see Figure 1.4) is a standard accessory for the Digitrip 1150 model. The module is installed on the molded platform under the trip unit in the Magnum Circuit Breaker. The module covers the following input voltage ratings: 120 VAC, 230 VAC, and 24/48 VDC. The burden of the Power/Relay Module is 10VA.

**1.6.1 Auxiliary Power**

When the module is wired and supplied with proper voltage, it will provide an auxiliary power supply so that the DT 1150's (LED) display will be functional even when the circuit breaker has no load. A Digitrip 1150 unit **without** auxiliary power will not display any data or communications.

**1.6.2 Alarm Contacts**

A second function of this module is to provide either a trip or alarm output contact via the two customer programmed relays within the module. An assortment of relay functions can be assigned to these relays. See the Aux Relay programming in Appendix D-15 and Appendix G. Each relay is a normally open contact with a programming identification of RELAY A and RELAY C. On the

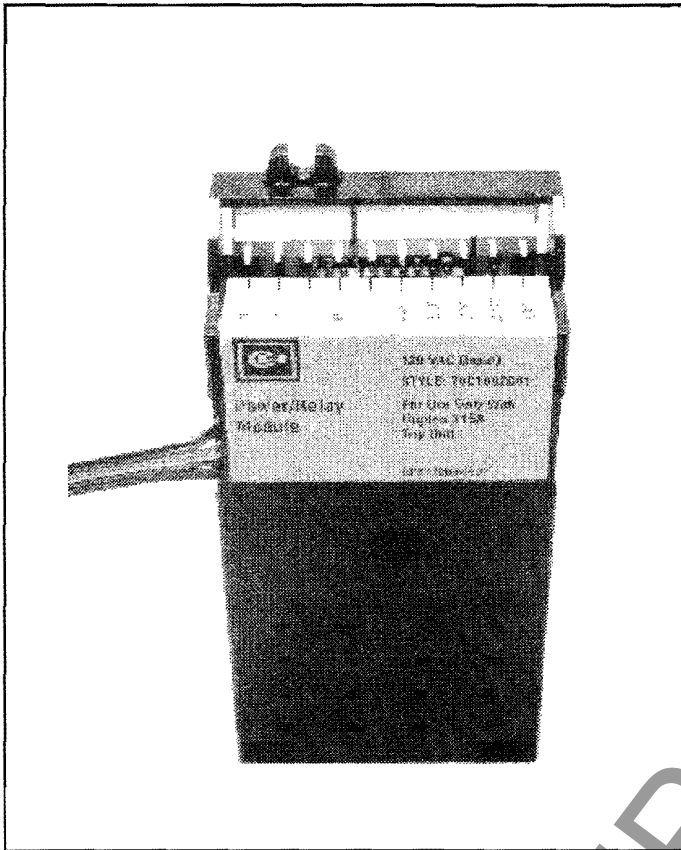

Figure 1.4 Power/Relay 1150 Trip Unit

Breaker Master Connection Diagram (Appendix C) these contacts are labeled ATR\_Alarm and ATR\_latch. The ATR\_latch is a latching relay that will hold contact status even if auxiliary power is lost to the breaker. This relay does require auxiliary power for resetting. The resetting of these relays requires depressing the RESET pushbutton on the front panel of the Digitrip 1150.

#### 1.6.2.2 Ground Alarm

A ground fault alarm is one of nine possible programmable alarms and can provide an early warning of a ground fault condition in progress via an alarm LED.

In addition, this unit can be programmed to energize an alarm relay upon this condition. The alarm relay will reset automatically if the ground current is less than the ground alarm pickup setting.

On the LSIA style unit, a red ALARM ONLY LED (see Figure 3.3) will indicate the presence of ground fault

current, when it is in excess of GROUND PICKUP setting. Ground tripping will not occur with the LSIA style unit.

#### 1.6.2.3 Block Close Relay

Also in this module is a relay that can block the remote closing of a circuit breaker after a trip condition. This Block function is enabled by programming the Aux Relay B via the front panel or via PowerNet communication. See Appendix D-15.

### 1.7 Standards

The Digitrip 1150 Trip Units are listed by the Underwriters Laboratories, Inc.<sup>®</sup> UL File E52096, for use in Magnum Circuit Breakers. These same units are also listed by the Canadian Standards Association (CSA) under file LR 43556.

All Digitrip units have also passed the IEC 947-2 test program which includes radiated and conducted emission testing. As a result, all units carry the CE mark.

## 2.0 GENERAL DESCRIPTION OF MAGNUM CIRCUIT BREAKERS

### 2.1 General

Magnum Circuit Breakers are tripped automatically on overload or fault current conditions by the combined action of three components:

1. The Sensors, which measure the current level and provide the energy to trip
2. The Digitrip Trip Unit, which provides a tripping signal to the Trip Actuator when current and time delay settings are exceeded
3. The low-energy Trip Actuator, which actually trips the circuit breaker

Figure 2.1 shows this tripping circuit for a typical Magnum Breaker. This arrangement provides a very flexible system, covering a wide range of tripping characteristics described by the time-current curves referenced in Section 9.2.

The automatic overload and short circuit tripping characteristics for a specific circuit breaker are determined by the ratings of the installed current sensors with a matching rating plug and the selected functional protection settings. Specific setting instructions are provided in Section 4.

When the functional protection settings are exceeded, the Digitrip unit supplies a trip signal to the Trip Actuator. As a result, all tripping operations initiated by the protection functions of the Digitrip Trip Unit are performed by its internal circuitry. There is no mechanical or direct mag-

netic action between the primary current and the mechanical tripping parts of the breaker, thus external control power is not required for overload or fault current tripping.

**! WARNING**

**IMPROPER POLARITY CONNECTIONS ON THE TRIP ACTUATOR COIL WILL DEFEAT THE OVERLOAD AND SHORT CIRCUIT PROTECTION, WHICH COULD RESULT IN PERSONAL INJURY.**

**OBSERVE POLARITY MARKINGS ON THE TRIP ACTUATOR LEADS AND CONNECT THEM PROPERLY USING THE INSTRUCTIONS PROVIDED.**

**2.2 Low-Energy Trip Actuator**

The mechanical force required to initiate the tripping action of a Magnum Circuit Breaker is provided by a special low-energy Trip Actuator. The Trip Actuator is located under the black molded platform on which the Digitrip unit is supported. The Trip Actuator contains a permanent magnet assembly, moving and stationary core assemblies, a spring and a coil. Nominal coil resistance is 25 ohms and the black lead is positive. The circuit breaker mechanism assembly contains a mechanism-actuated reset lever and

a trip lever to actuate the tripping action of the circuit breaker.

When the Trip Actuator is reset by the operating mechanism, the moving core assembly is held in readiness against the force of the compressed spring by the permanent magnet. When a tripping action is initiated, the low-energy Trip Actuator coil receives a tripping pulse from the Digitrip unit. This pulse overcomes the holding effect of the permanent magnet, and the moving core is released to trigger the tripping operation via the trip lever.

**2.3 Ground Fault Protection**

Only the Digitrip 1150 cat# 11LSIG and Digitrip 1150*i* cat# 11IEC-EF provide ground fault protection.

**2.3.1 General**

When the Digitrip 1150 family includes ground fault protection features, the distribution system characteristics (for example, system grounding, number of sources, number and location of ground points, and the like) must be considered along with the manner and location in which

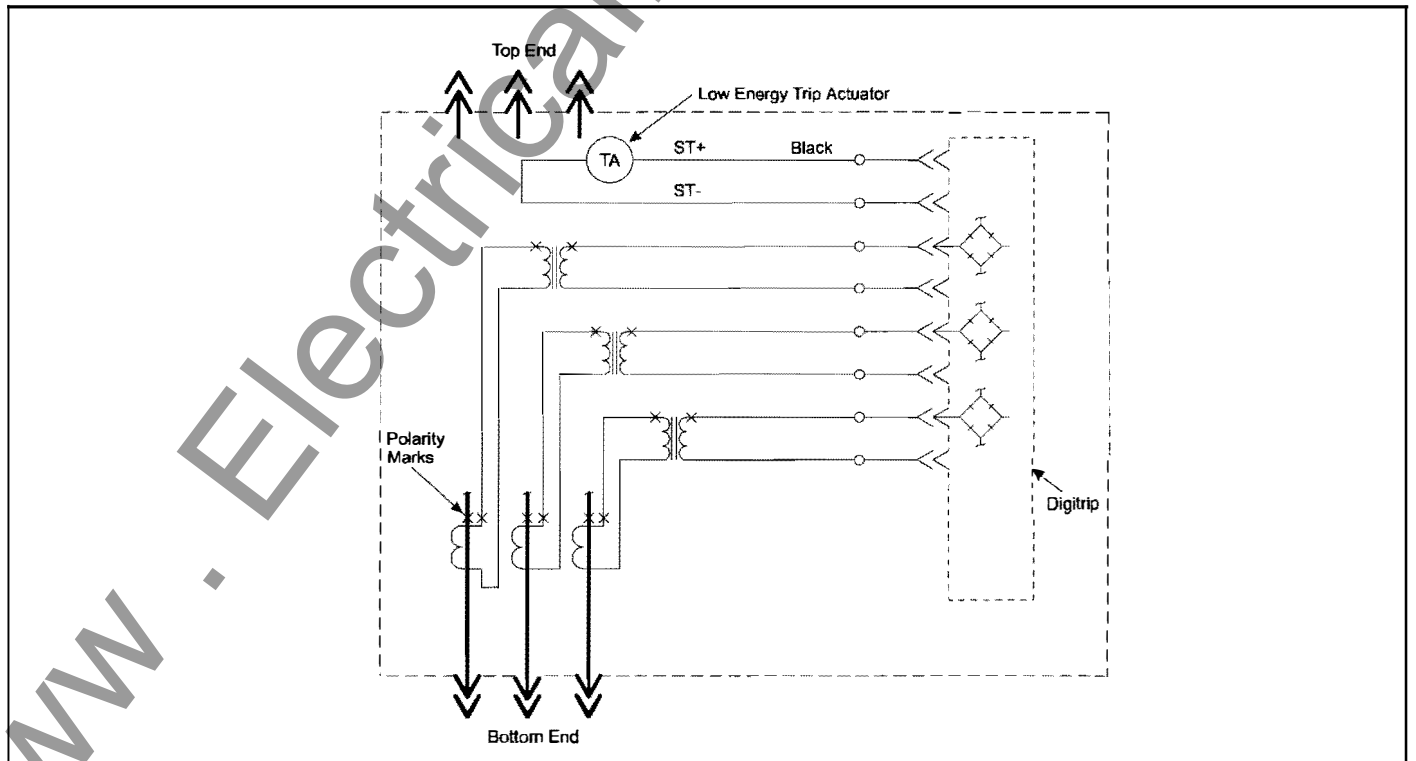

Figure 2.1 Tripping Circuit for a Typical Magnum Breaker (Partial)

the circuit breaker is applied to the system. These elements are discussed in Sections 2.3.3 through 2.3.6.

The Digitrip 1150 family uses three modes of sensing to detect ground fault currents: residual, source ground, and zero sequence (see Table 2.1). The breaker secondary contact inputs B-6 and B-7 are used to configure the trip unit. A jumper from B-6 to B-7 programs the trip unit for either a source ground or zero sequence configuration. Removing the jumper will program the unit for a residual ground fault scheme. This jumper resides on the stationary side of the switchgear assembly. In all three schemes, the proper current sensor input is required on the external sensor input terminals B-4, B-5 of the breaker secondary contacts.

Table 2.1 Digitrip Sensing Modes

Ground (Earth) Fault Sensing Method	Breaker Secondary Contacts Req'd	Applicable Breakers	Figure Reference	Digitrip GF Sensing Element Used
Residual	No Jumper	3 or 4 pole	2.2, 2.3, 2.5, 2.9	element R5
Source Ground	Jumper B6 to B7	3 pole only	2.7	element R4
Zero Sequence	Jumper B6 to B7	3 pole only	2.8	element R4

Note: This information applies to Trip Units with Ground

### 2.3.2 Residual Sensing

Residual Sensing is the standard mode of ground fault sensing in Magnum Circuit Breakers. This mode utilizes one current sensor on each phase conductor and one on the neutral for a 4-wire system (shown in Figures 2.2 and 2.3). If the system neutral is grounded, and no phase to neutral loads are used, the Digitrip 1150 with ground includes all of the components necessary for ground fault protection. This mode of sensing vectorially sums the outputs of the three or four individual current sensors. For separately-mounted neutrals, as long as the vectorial sum is zero, then no ground fault exists. The neutral sensor must have characteristics and a ratio which matches the three internally-mounted phase current sensors. Available types of neutral sensors are shown in Figure 2.4. Residual ground fault sensing features are adaptable to main and feeder breaker applications.

## ! CAUTION

**IF THE SENSOR CONNECTIONS ARE INCORRECT, A NUISANCE TRIP MAY OCCUR. ALWAYS OBSERVE THE POLARITY MARKINGS ON THE INSTALLATION DRAWINGS. TO INSURE CORRECT GROUND FAULT EQUIP-**

## MENT PERFORMANCE, CONDUCT FIELD TESTS TO COMPLY WITH NEC REQUIREMENTS UNDER ARTICLE 230-95(C).

### 2.3.3 Source Ground Sensing

Depending upon the installation requirements, alternate ground fault sensing schemes may be dictated (see Figures 2.6 and 2.7). The ground return method is usually applied when ground fault protection is desired only on the main circuit breaker in a simple radial system. This method is also applicable to double-ended systems where a midpoint grounding electrode is employed. For this mode of sensing, a single current sensor mounted on the equipment-bonding jumper directly measures the total ground current flowing in the grounding electrode conductor and all other equipment-grounding conductors.

In the CURRENT (protection) submenu, there is a setting (EXT GND CT RATIO) that enables the presentation of ground pickup in amperes and the display of ground current in amperes when an External Ground CT is employed. This screen is presented when jumper B-6 to B-7 is present on a trip unit equipped with GROUND. External Ground CT ratios of 10, 100, 200, 400, 800, 1000 A:1 and "none" settings are selectable, with "none" defaulting to the plug (In) rating. With the correct ratio selected the GF pickup settings are adjustable in amperes.

### 2.3.4 Zero Sequence Sensing

Zero Sequence Sensing, also referred to as vectorial summation (see Figure 2.8), is applicable to mains, feeders, and special schemes involving zone protection. Zero Sequence current transformers (4 1/2" x 13 1/2" [114 mm x 342 mm] rectangular inside dimensions) are available with 100:1 and 1000:1 ratios. The EXT GND CT RATIO setting described above is applicable for zero sequence.

### 2.3.5 Multiple Source/Multiple Ground

A Multiple Source/Multiple Ground scheme is shown in Figure 2.9. In this figure, a ground fault is shown which has two possible return paths, via the neutral, back to its source. The three neutral sensors are interconnected to sense and detect both ground fault and neutral currents.

Call Cutler-Hammer for more details on this scheme.

### 2.3.6 Ground Fault Settings

The adjustment of the ground fault functional settings and their effect upon the ground fault time-current curve is discussed in Section 4.2.1.7.

### 2.4 Current Sensors (Magnum Frames less than or equal to 3200A)

The three (3-pole) or four (4-pole) primary current sensors are located in the circuit breaker on the lower conductors of the breaker. The current sensor rating defines the breaker rating ( $I_n$ ). For example, 2000A:1A sensors are used on a 2000A rated breaker. There are also four auxiliary current transformers with a ratio of 10:1 which further step down the rated current to 100 milliamperes, which is equivalent to 100% ( $I_n$ ) in the Digitrip 1150.

The primary current sensors produce an output proportional to the load current and furnish the Digitrip 1150 family with the information and energy required to trip the circuit breaker when functional protection settings are exceeded.

## WARNING

**IF A SET OF CURRENT SENSORS WITH A DIFFERENT RATIO ARE INSTALLED IN THE FIELD, THE RATING PLUG MUST ALSO BE CHANGED. THE ASSOCIATED RATING PLUG MUST MATCH THE CURRENT SENSOR RATING SPECIFIED ON THE PLUG LABEL. THE CURRENT SENSOR RATING CAN BE VIEWED THROUGH OPENINGS IN THE BACK OF THE BREAKER. ALSO VERIFY DESIRED PROTECTION SETTINGS AFTER THESE COMPONENTS ARE CHANGED.**

### 2.5 Current Sensors (Magnum Frames greater than 3200A)

The six (3-pole) or eight (4-pole) current sensors installed in the circuit breaker are located on the lower conductors. The poles are paralleled and the corresponding current sensors are also paralleled (see Figure 2.3), for example, a 4000A breaker phase rating has two 2000:1 current sensors wired in parallel, which provides an overall ratio of 4000:2. The auxiliary current transformers have a ratio of 20:1 in this size breaker to further step down the full load current to 100 mA.

## 3.0 PRINCIPLES OF OPERATION

### 3.1 General

The Digitrip 1150 family of trip units is designed for industrial circuit breaker environments where the ambient temperatures can range from  $-20^{\circ}\text{C}$  to  $+85^{\circ}\text{C}$  but rarely exceed  $70^{\circ}$  to  $75^{\circ}\text{C}$ . If, however, ambient temperatures

exceed this range, the trip unit performance may be degraded. In order to insure that the tripping function is not compromised due to an over-temperature condition, the Digitrip 1150 microcomputer chip has a built-in over-temperature protection feature, factory set to trip the breaker if the chip temperature is excessive. If the unit trips on over-temperature, the red Long Delay Time LED will flash and the OVER TEMP TRIP message will appear on the display.

The Digitrip uses the Cutler-Hammer custom-designed S $\mu$ RE+CHIP<sup>™</sup>, an integrated circuit that includes a microcomputer to perform its numeric and logic functions. The principles of operation of the trip unit are shown in Figure 3.1.

All sensing and tripping power required to operate the protection function is derived from the current sensor secondary currents whenever the circuit breaker is carrying current. These current signals develop analog voltages across the current viewing resistors. The resulting analog voltages are digitized by the S $\mu$ RE+CHIP<sup>™</sup>.

The microcomputer continually digitizes these signals. This data is used to calculate true RMS current values, which are then continually compared with the protection function settings and other operating data stored in the memory. The embedded software then determines whether to initiate protection functions, including tripping the breaker through the Trip Actuator.

### 3.2 Trip and Operation Indicators

The four cause of trip LEDs on the face of the trip unit, shown in Figures 1.1 and 3.2 to 3.5, flash red to indicate the reason for any automatic trip operation. Each LED is strategically located in the related segment of the time-current curve depicted on the face of the trip unit. The reason for the trip is identified by the segment of the time-current curve where the LED is illuminated. Following an automatic trip operation, the backup battery shown in Figure 3.1 continues to supply power to the LEDs. The LED pulse circuit, also shown in Figure 3.1, is provided to reduce battery burden and will flash the trip LED approximately every 4 seconds. Therefore, it is important to view the unit for at least 5 seconds to detect a flashing cause of trip indicator. Pushing the Reset button extinguishes the LED.

#### 3.2.1 Status/Long Pickup LED

The green Status LED will indicate the operational status of the protection S $\mu$ RE A chip of the trip unit. Even with

no external power present, if the load current through the circuit breaker exceeds approximately 12 percent (3 phase power) of the current sensor rating, the LED will flash on and off once each second indicating that the trip unit is energized and operating properly. (See Figure 3.1)

In an overload (Long Pickup) condition this status LED flashes at approximately 4 times per second while the overload persists.

### 3.2.2 Alarm LED

In addition to the green status LED, a yellow alarm LED is provided to indicate real time alarm conditions existing on the power system. See Appendix D-16 for the programing of these alarms. Also, if an unusual condition is detected within the Digitrip's hardware or firmware, this LED will light along with an ALARM message.

### 3.2.3 Trip LED

The trip LED is illuminated upon any trip condition. It is also a real time display and incorporates the breaker's auxiliary switch input for its logic. Pushing the Reset pushbutton or closing the breaker will clear this LED.

## 3.3 Making Current Release

All Digitrip 1150 Trip Units have a Making Current Release function. This safety feature prevents the circuit breaker from being closed and latched-in on a faulted circuit. This is a nonadjustable sensing circuit. It is preset to trip at an instantaneous current numerically equivalent to  $25 \times (I_n)$ . (Note that currents of  $\sim 11 \times (I_n)$  with maximum asymmetry also reach this threshold.)

The Making Current Release is enabled only for the first two cycles following an initial circuit breaker closing operation. The Making Current Release will trip the circuit breaker instantaneously and flash the Instantaneous LED as well as indicating "Making Current Trip" on the display panel.

## 3.4 Zone Interlocking

### CAUTION

**IF ZONE INTERLOCKING IS NOT TO BE USED AND ONLY STANDARD TIME-DELAY COORDINATION IS INTENDED, JUMPER TERMINAL B8 TO B9 ON THE BREAKER SECONDARY CONNECTOR.**

Zone Selective Interlocking (or Zone Interlocking) is available on the Digitrip 1150 for the Short Delay and

Ground Fault protection functions (see Figure 3.1). The zone interlocking signal is wired via a single set of wires labeled Zone In ( $Z_{in}$ ) and Zone Out ( $Z_{out}$ ) along with a Zone Common wire. The Zone Selective Interlocking function combines the interlocking of Short Delay and Ground Fault. A zone out signal is issued if the ground fault pickup is exceeded or if the short delay pickup is exceeded or if the value of  $2 \times (I_r)$  is exceeded. Zone Selective Interlocking provides the fastest possible tripping for faults within the zone of protection of the breaker and yet also provides positive coordination among all breakers in the system (mains, ties, feeders, and downstream breakers) to limit a power outage to only the affected parts of the system. When Zone Interlocking is employed, a fault within the zone of protection of the breaker will cause the Digitrip 1150 to:

- Trip the affected breaker immediately and, at the same time,
- Issue a signal to upstream Digitrip units to restrain from tripping immediately. The restraining signal causes the upstream breakers to follow their set coordination times, so that the service is only locally disrupted while the fault is cleared in the shortest time possible.

For an example of how Zone Selective Interlocking may be used, see Appendix A of this Instructional Leaflet.

## 3.5 PT Module

The PT Module is internally wired in the breaker to the line side breaker terminals. It provides signal data to calculate voltage, power, energy and related data. The PT module is a three phase, three wire input and three wire output step down transformer with a wye to wye hookup.

### CAUTION

**A DIELECTRIC DISCONNECT PLUG LOCATED ON THE LEFT SIDE OF THE BREAKER IS PROVIDED WITH THIS MODULE AND IS TO BE REMOVED WHEN DIELECTRIC TESTING OF THE BREAKER IS CONDUCTED. FAILURE TO REMOVE PLUG WHEN TESTING CAN RESULT IN DAMAGE TO TRIP UNIT AND PT MODULE.**

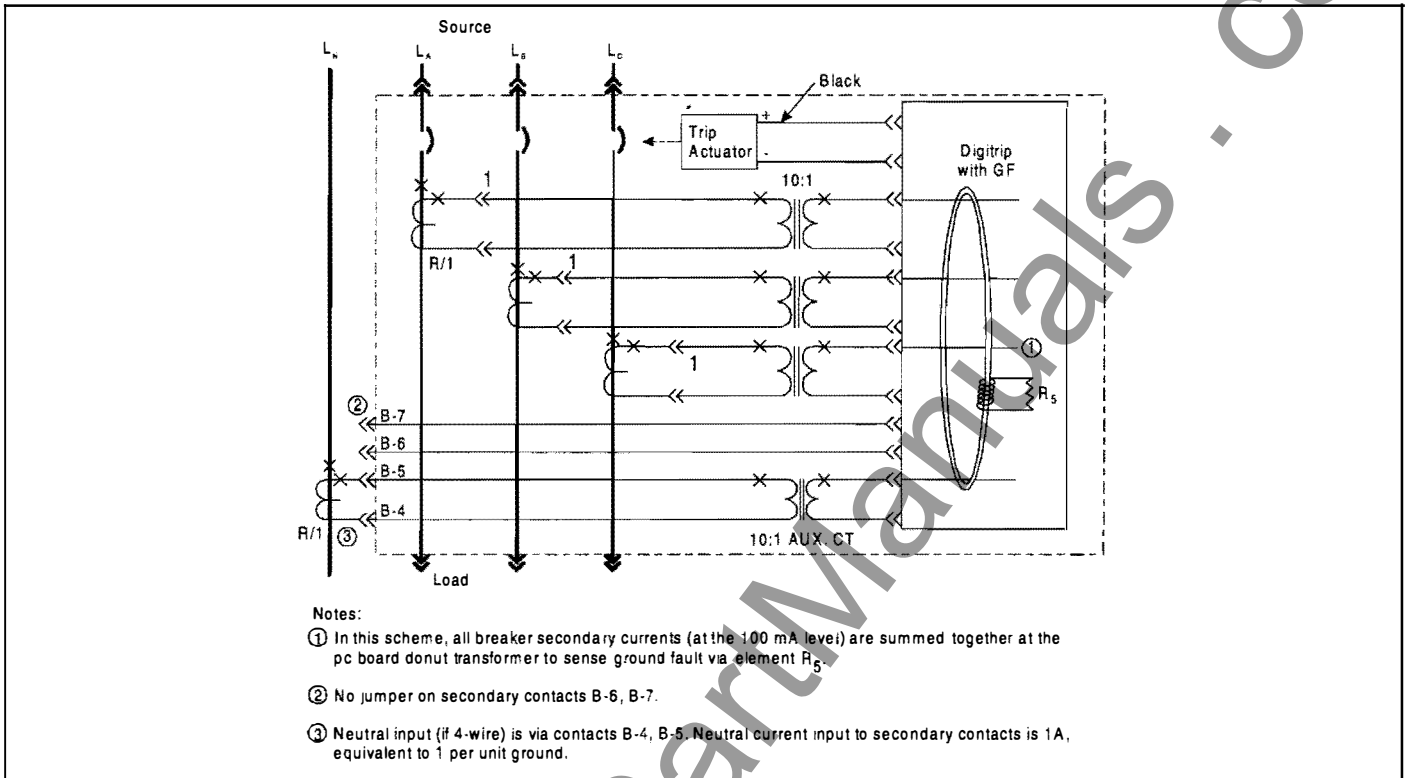

Figure 2.2 3-Pole, 4-Wire Breaker with Neutral Sensor Connections for 3200A Frame Using Residual GF Sensing

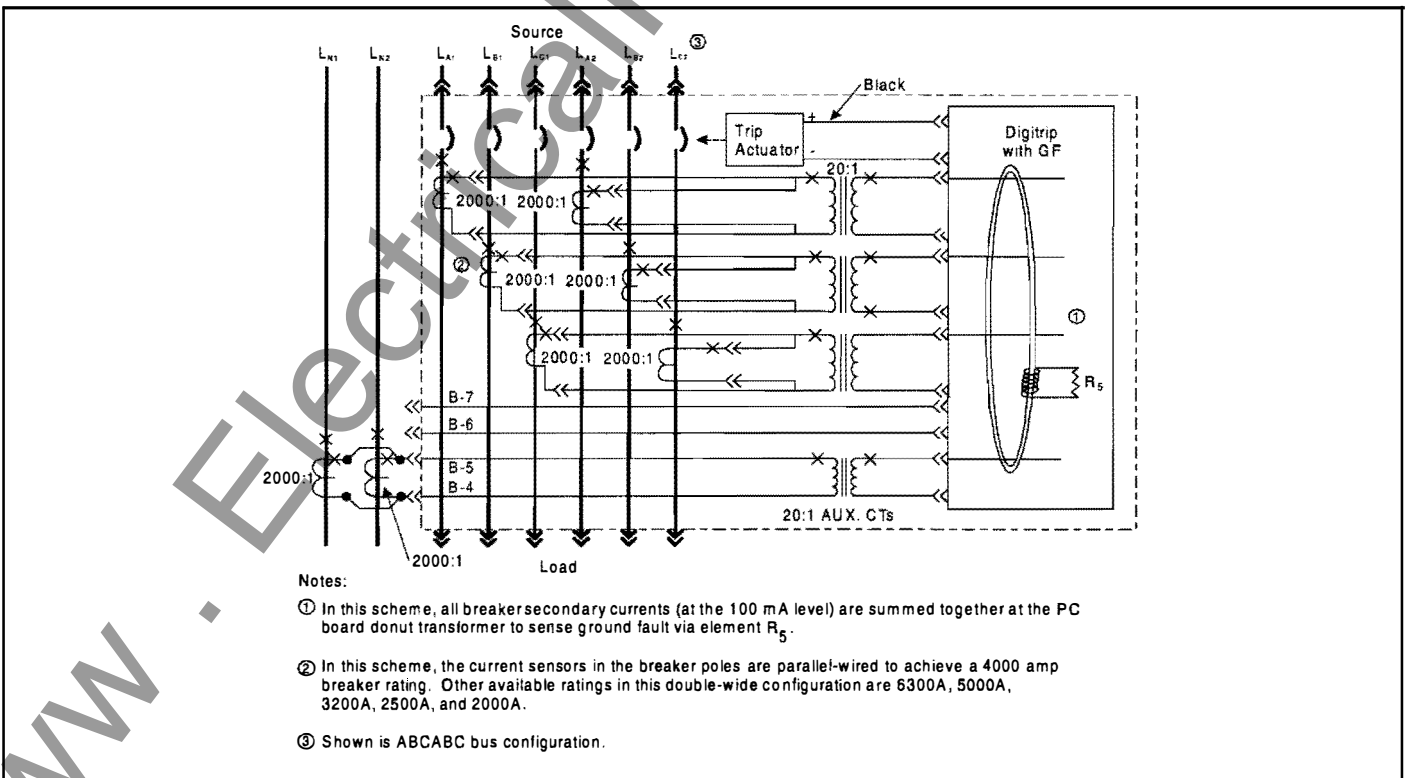

Figure 2.3 Neutral Sensor Connections for 4000A Frame Using Residual Ground Fault Sensing

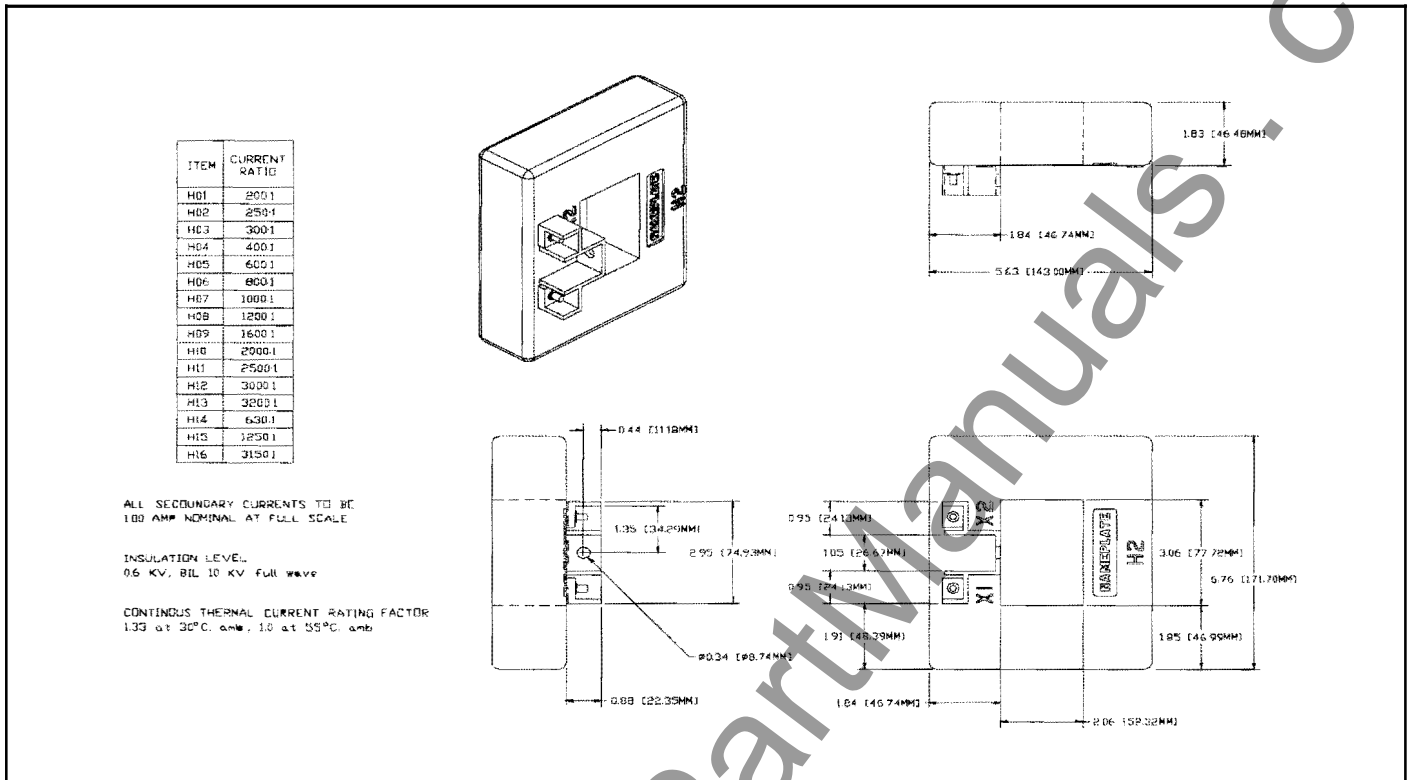

Figure 2.4 Digitrip Neutral Sensor Types

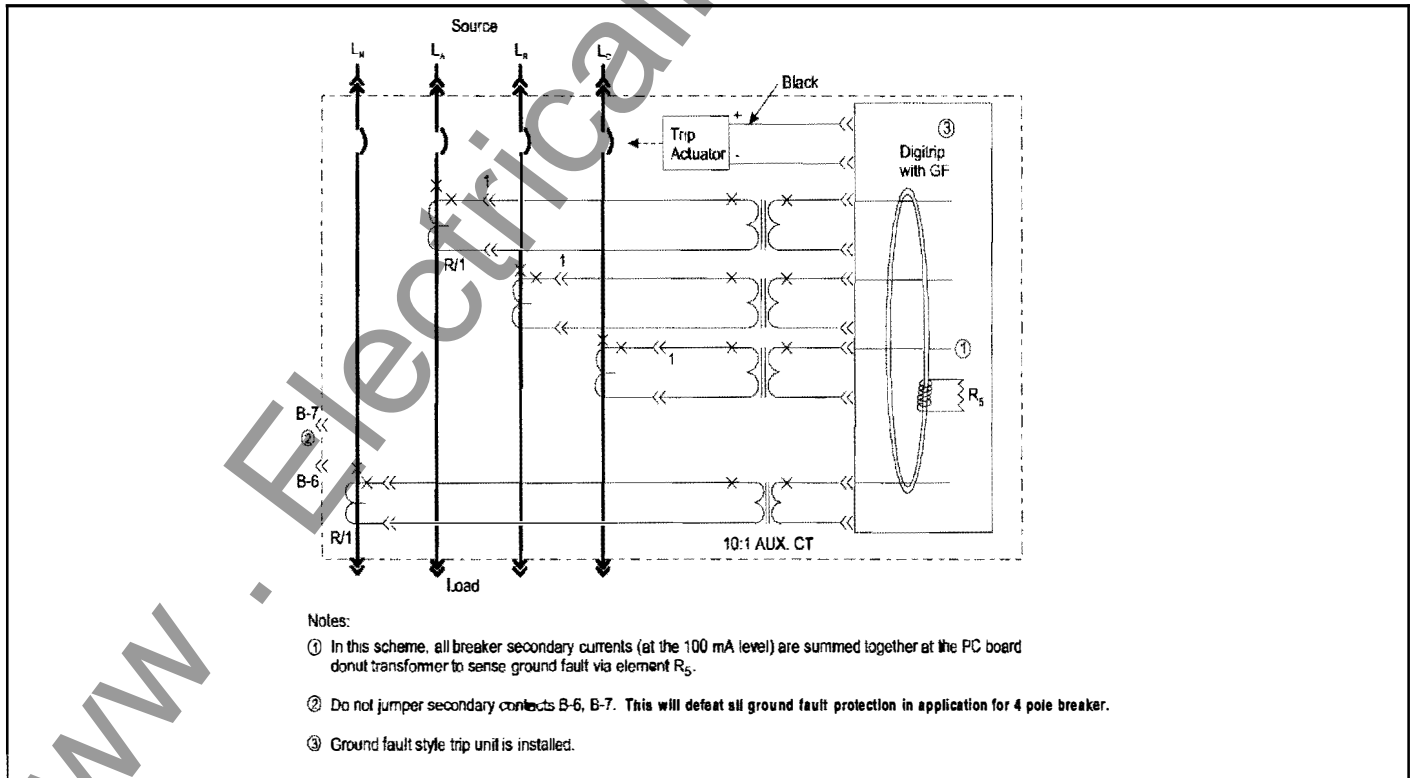

Figure 2.5 4-Pole-3200A Frame Using Residual Ground Fault (Earth-Fault) Sensing

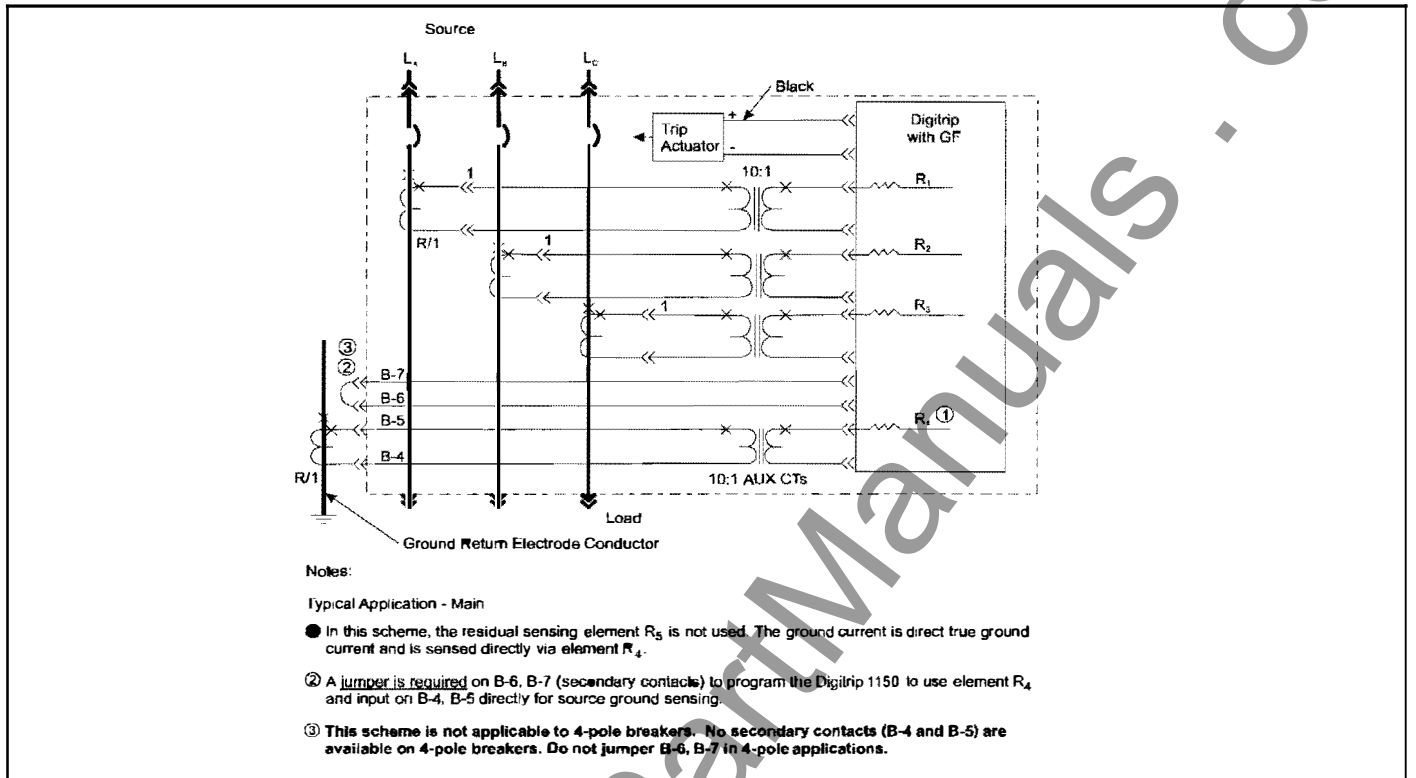

Figure 2.6 Source Ground Fault Sensing Scheme for 3200A Frame

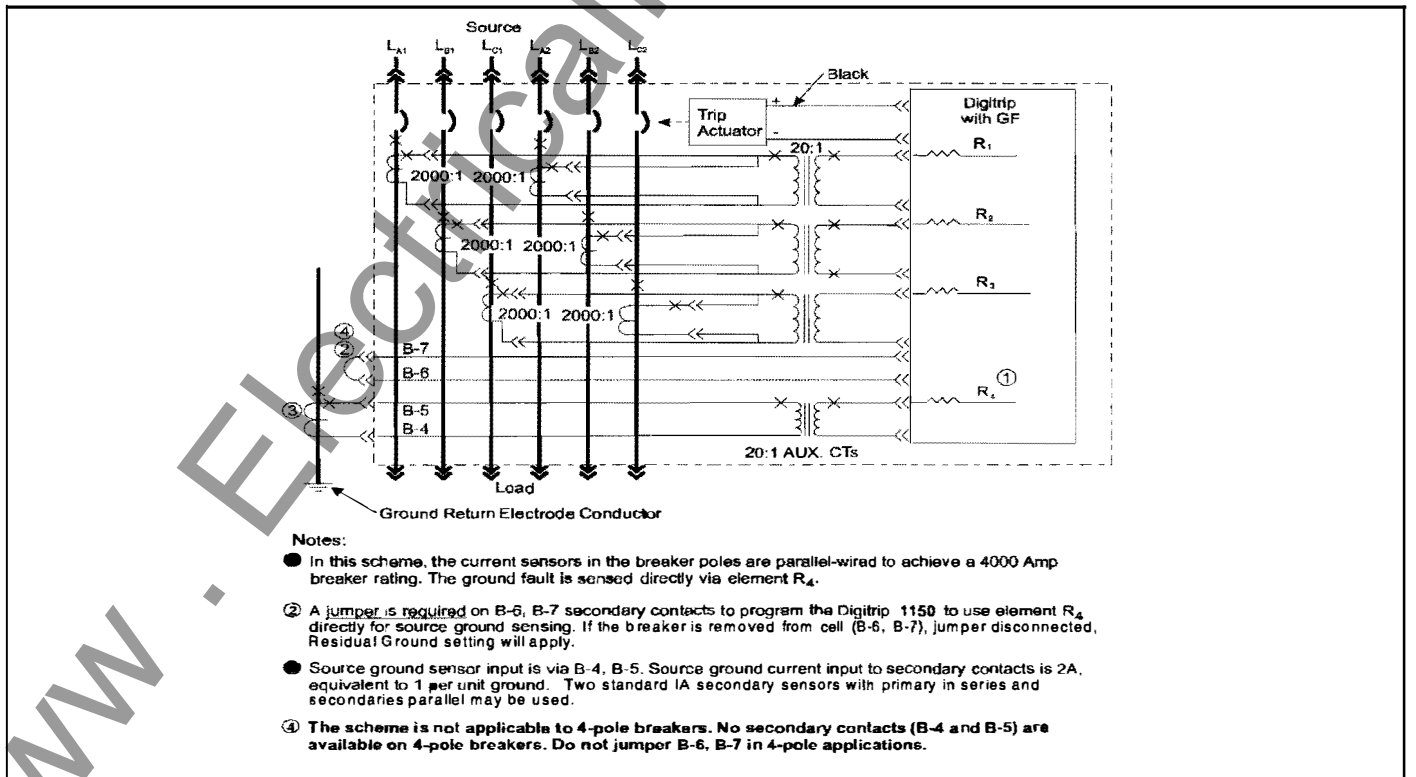

Figure 2.7 Source Ground Fault Sensing Scheme for 4000A Frame

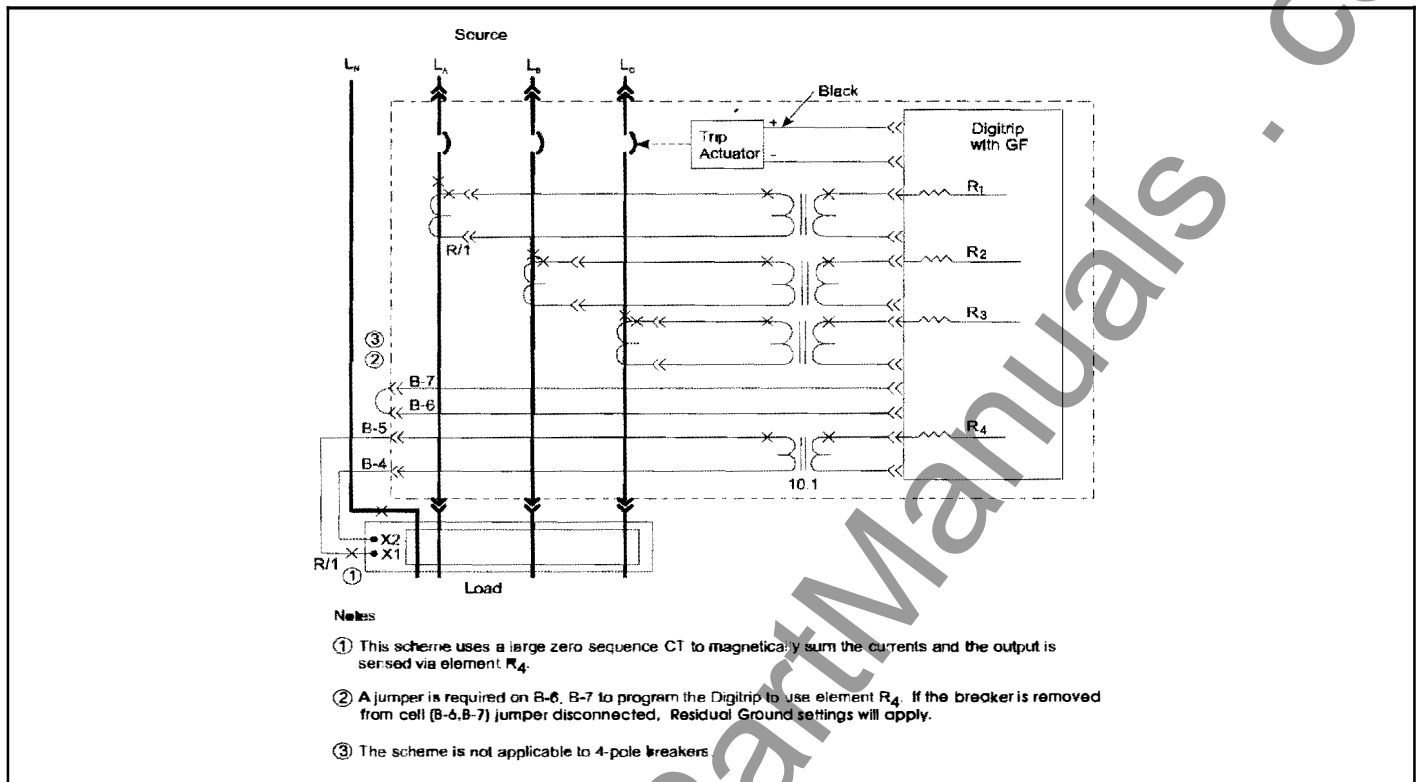

Figure 2.8 Zero Sequence Sensing Scheme for 3200A Frame

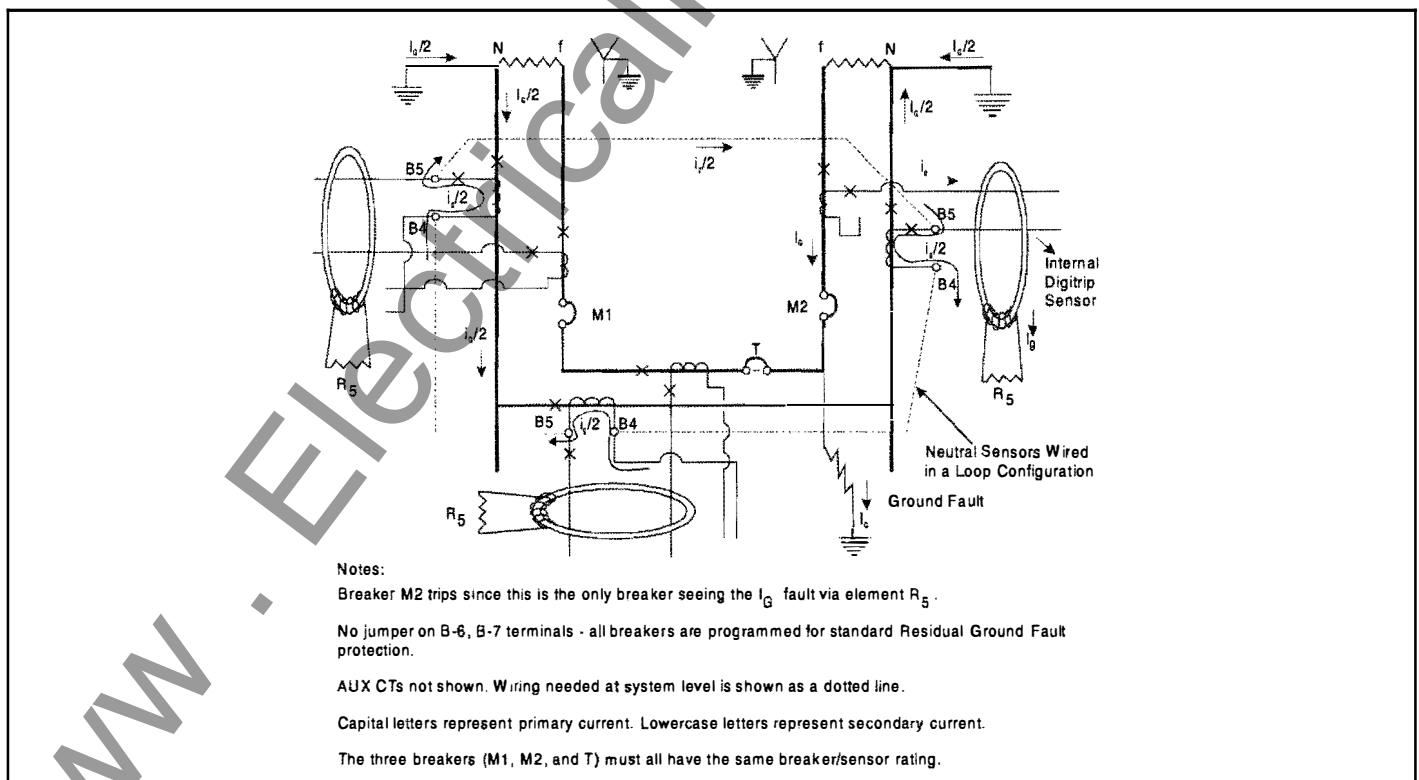

Figure 2.9 Multiple Source/Multiple Ground Scheme

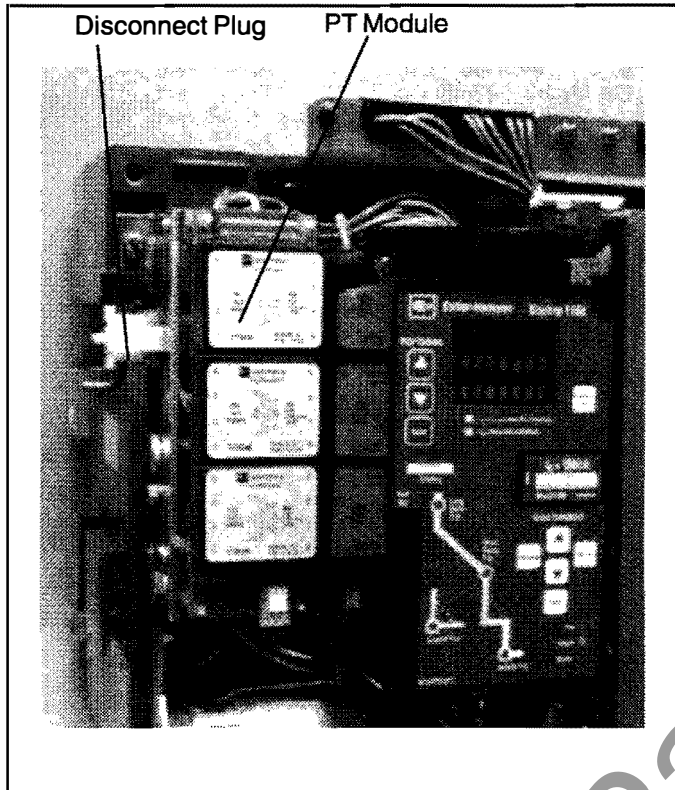

Figure 2.10 PT Module with Dielectric Disconnect Plug

## 4.0 PROGRAMMING/VIEWING DIGITRIP 1150 via FRONT PANEL

### 4.1 Main Menu

#### 4.1.0 Power Up Sequence

When the Digitrip 1150/1150i unit is first powered-up, two different display messages are possible. If the Digitrip has been previously commissioned with customer-made settings, the display will alternate between "Cutler-Hammer DT 1150" and "Customer Settings in Use" messages. Following this the display will enter into the main menu. See Appendix D-1.

If Digitrip settings have not been saved previously the trip unit is using the factory default values. On power up, the Digitrip will then display "CHANGE FACTORY SETUP?". This message will stay on the screen until the user presses ESCape or the SElect pushbutton or until an alarm or trip condition is detected.

The ESCape pushbutton action will keep the factory settings and then will enter the main menu. The factory settings are listed in Appendix D-23 and are not valid for most applications. The appropriate settings need to be defined by a qualified application engineer to provide best overall protection and coordination for the power system.

A SElect pushbutton action will provide direct entry into PROGRAM SETTING menu. The first item presented is the Current CURVE type. LSIG or IEEE or (IEC) current curve types are possible selections depending on trip unit style. Pressing SElect again will select the curve presented in the window center and then step into the individual elements that need programmed. The VIEW up and down arrow selects the function while the EDIT up and down arrow changes value. After they are set they need to be saved by depressing the SAVE pushbutton. The saving will place the customer settings in use. Verify the new settings. See Appendix D-13 for program curve and D-19 for saving and D-5 for view setting menu.

#### 4.1.1 Pushbutton Definition

##### View Functions

The "View Functions" group of pushbuttons is located in the lower right hand side of the unit and includes the View Up (up arrow), View Down (down arrow), ESCape, SElect, and Reset buttons.

*View Up / View Down* - View Up and View Down allow the user to scroll through any available menu or submenu in the Digitrip 1150 display.

*SElect* - The SElect pushbutton selects the submenu for the blinking selection located in the middle of the display.

*ESCape* - The ESCape pushbutton brings the user up to the previous menu in the display. Multiple ESC pushbutton operation will display Main Menu screen.

*Reset* - The Reset pushbutton will reset LEDs and screen data. (See Reset Sequence)

##### Edit Values

The "Edit Values" group located in the upper left hand corner of the Digitrip 1150 unit consists of 3 pushbuttons: Edit Up (indicated by an up arrow), Edit Down (down arrow) and Save. The Edit Values pushbuttons are covered by a Plexiglass cover which can be sealed.

*Edit Up / Edit Down* - Edit Up and Edit Down allow the user to scroll up or down, respectively, through available setting values while in any Program Settings submenu.

*Save* - The Save pushbutton allows the user to save a group of selected programmable settings from any submenu in the PGM SET menu. Save is also used in the TEST Menu. When prompted, pressing Save will begin the selected test.



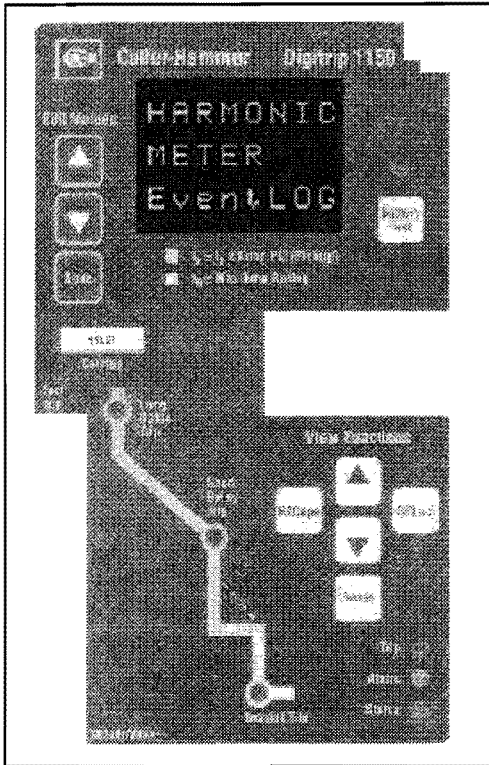

Figure 3.2 Digitrip 1150 LSI

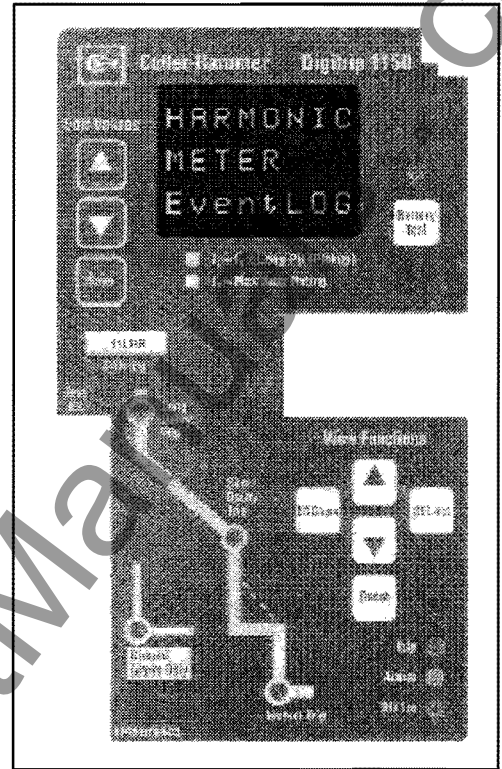

Figure 3.3 Digitrip 1150 LSIA

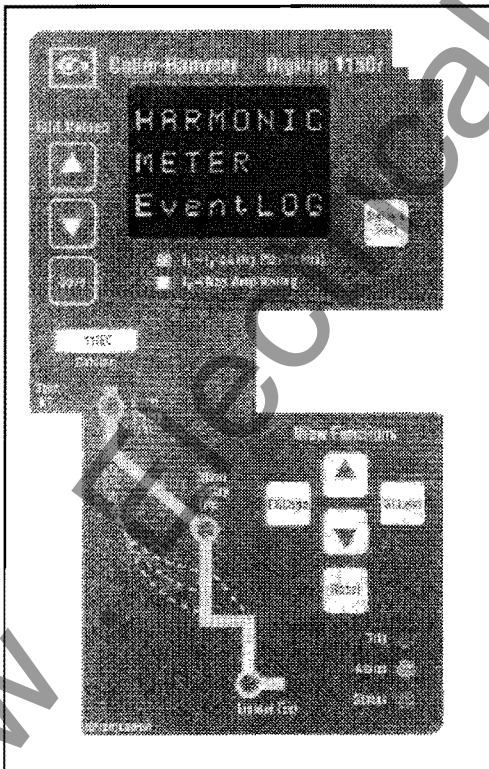

Figure 3.4 Digitrip 1150i IEC

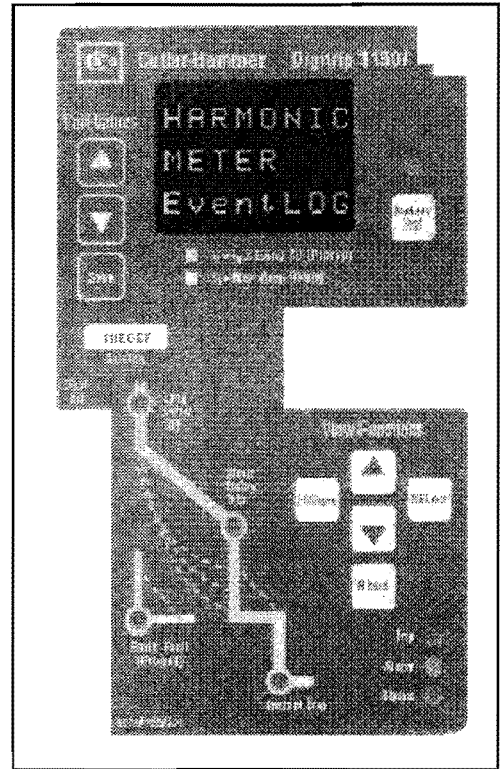

Figure 3.5 Digitrip 1150i IEC-EF

## Battery Test

The Battery Test pushbutton is located on the right side of the Digitrip 1150 unit, just above the rating plug door. Battery Test will light the green LED located above the pushbutton to ensure proper voltage in the battery.

### 4.1.2 Blink mode

#### Middle Blinking

The middle display, if blinking, indicates that the menu item is selectable or that a submenu exists when a selection brings up another menu with middle text blinking.

### 4.1.3 Programming/Viewing Screens

The View Functions control screen viewing, while Edit Functions apply to programming and storing settings. **ALWAYS VERIFY PROGRAMMED SETTINGS BY ENTERING VIEW SETTINGS AFTER SAVING.** All screens are viewable depending on the programmed settings and/or Digitrip 1150 model. In particular, the METER submenu may be programmed to include anywhere from one to 22 viewable screens when METER is selected, based on the settings chosen in the PGM SET\DISPLAY screens. Similarly, certain screens are only viewable based on availability. For example, in the PGM SET\AuxRLY menu, the selected relay determines the programmable groups displayed. See Appendix D.

Depending on the Digitrip 1150 model, certain menus or screens are not viewable or programmable. When using the LSI factory style unit, viewing and programming menu screens involving Ground or Earth settings are not accessible. When using the LSIG factory style unit, viewing and programming screens involving Neutral Protection are not displayed.

### 4.1.4 Reset Pushbutton Operation

#### 4.1.4.1 Trip Events

A Reset pushbutton operation does the following after a trip:

- Clears the cause of trip flashing LEDs (4) after a trip event
- Clears the Trip LED
- Clears Display data

#### Note: After a Trip Event

- Observe any Trip LED flashing on Mimic Curve.
- Observe message on LED display.
- Push View Down pushbutton to observe

timestamp of event and view down to observe trip current data. This data, along with timestamp will also be stored in Event Log.

**4. After any trip condition, the trip unit should be reset by pressing the Reset Pushbutton. Reclose breaker as desired.**

See Appendix D-4 for possible Trip Events and screen data displayed after a trip by using the View Down (down arrow) pushbutton.

#### 4.1.4.2 Alarm Events

Alarms are tracked in real time and a Reset pushbutton may momentarily clear the alarm but the Alarm LED and Alarm message will reappear if condition is still present.

The ESCape pushbutton activation will remove the alarm message from the display and return to normal menu viewing mode, but the yellow alarm LED will remain lit, as the alarm is in the system. See Appendix D-22.

**Note:** A way to clear an alarm if desired, after reviewing the alarm and its associated data, is to enter the PGM SET Menu followed by the ALARM submenu. The user can then revise or turn off the associated alarm set point value.

See Appendix D-4 for possible Alarm Events and D-22 for multiple Alarm conditions.

#### 4.1.4.3 Data resets in Meter screen

A Reset pushbutton operation will reset data values or group of values if the Reset pushbutton is depressed when screen value is displayed. See Appendix D-3 Meter Menu.

## 4.2 Program Settings PGM SET

### 4.2.1 Curve Type Selection and Pickup/Time Settings

#### 4.2.1.0 General

Before placing any circuit breaker in operation, set each trip unit protection setting to the values specified by the engineer responsible for the installation. Each setting is programmed using the front panel pushbuttons and Save when the desired settings are selected. A few settings are interdependent (the LONG PU ( $t_r$ ) rating will indirectly affect the SHORT PU value). Therefore, **always verify these settings after programming by entering View Settings Menu.**

The installed rating plug must match the current sensors which establish the maximum continuous current rating of

the circuit breaker ( $I_n$ ). Instantaneous and ground current settings are defined in multiples of ( $I_n$ ).

To illustrate the effect of each protection setting, simulated time-current curves are pictured on the face of the trip unit. Should an automatic trip occur (as a result of the current exceeding the pre-selected value), the LED in the appropriate segment of the simulated time-current curve will flash red, indicating the reason for the trip.

All Digitrip 1150 and Digitrip 1150i offer the LSI(G) curve as the standard factory default. The five segment straight line curve of LONG PU and Time, SHORT PU and Time, and INSTantaneous PU are depicted on the nameplate of the product. The GROUND (EARTH) element is shown also on styles with Ground Fault Protection. The LSIA style has Ground Alarm only function. See Appendix D-12.

A second curve selection is also possible for UL/ANSI styles. An IEEE curve that accurately follows the Inverse-Time characteristic equations can be selected (IEEE draft PC37.112-11/95). Curve shapes of moderately inverse, very inverse or extremely inverse are available under PHASE SLOPE. Each of these curve shapes have a PICKUP and TimeDIAL selection to position the curve. The short delay function is included as part of IEEE curve.

For the Digitrip 1150i, a second curve type is also possible for the international styles. An IEC curve type that accurately follows the IEC255 curve equations can be selected. The curve shapes of IEC-A (normal inverse), IEC-B (very inverse) and IEC-C (extremely inverse) are available under PHASE SLOPE. Each of these curve shapes have a PICKUP and TimeDIAL selection to position the curve. The short delay function is included as part of IEC curve.

The available settings, for the LSI(G) standard curve along with the effects of changing the settings, are described below and in Figures 4.1 through 4.8. Sample settings are represented in boxes (e.g. 2).

4.2.1.1 LONG SLOPE Setting

There is a  $I^2t$  or  $I^4t$  curve shape selection possible for LONG SLOPE.

4.2.1.2 LONG PU Setting

There are 13 available Long Delay Settings, as illustrated in Figure 4.1. Each setting, called ( $I_r$ ), is expressed as a multiple (ranging from .4 to 1) of the current ( $I_n$ ).

**NOTE:** ( $I_r$ ) is also the basis for the Short Delay Current Setting (see Section 4.4).

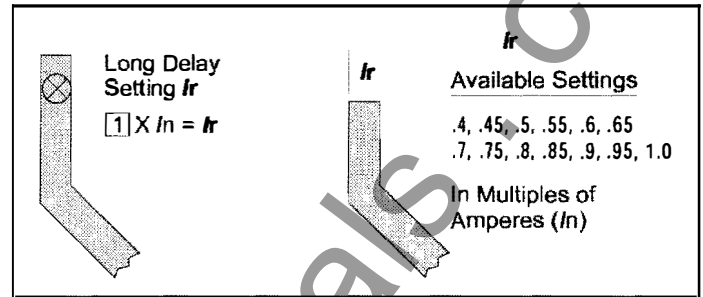

Figure 4.1 Long Delay Current Settings

4.2.1.3 Long TIME Setting

There are 45 available Long Delay Time Settings  $I^2T$ , as illustrated in Figure 4.2, ranging from 2 to 24 seconds. For the  $I^4t$  slope there are 9 settings ranging from 1 to 5 seconds. These settings are the total clearing times when the current value equals 6 times ( $I_r$ ).

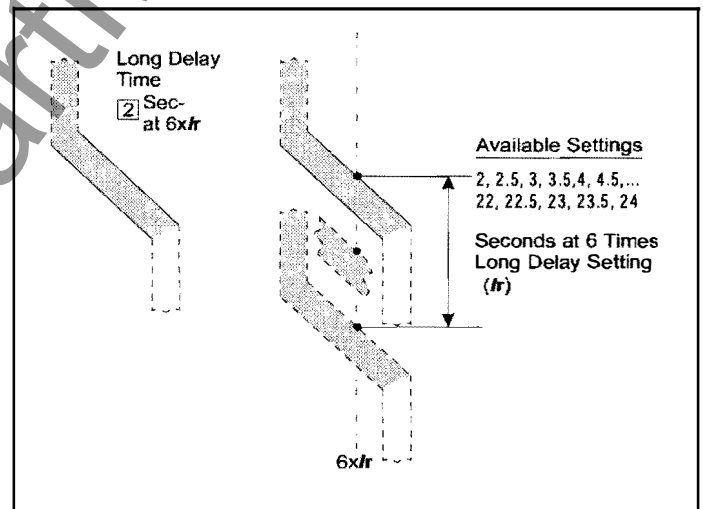

Figure 4.2 Long Delay Time Settings

**NOTE:** In addition to the standard Long Delay Protection Element, the Digitrip 1150 trip units using LONG SLOPE settings of  $I^2t$  or  $I^4t$  also have a Long Time Memory (LTM) function, which protects load circuits from the effects of repeated overload conditions. If a breaker is closed soon after a Long Delay Trip, and the current again exceeds the Long Delay Setting, ( $I_r$ ), the LTM automatically reduces the time to trip to allow for the fact that the load circuit temperature is already higher than normal because of the prior overload condition. Each time the overload condition is repeated, the LTM causes the breaker to trip in a progressively shorter time. When the load current returns to normal, the LTM begins to reset; after about 10 minutes it will have reset fully, so the next Long Delay trip time will again correspond to the Setting value.

**NOTE:** In certain applications, it may be desirable to disable the LTM function by disabling this function in Program Settings.

The action of the LTM must be considered when performing multiple Long Delay Time tests (see Section 5.4).

**4.2.1.4 SHORT PU Setting**

There are 19 available Short Delay Current Settings, as illustrated in Figure 4.4. Eighteen settings are in the range from 1.5 to 10 times ( $I_r$ ). (**REMEMBER:** ( $I_r$ ) is the Long Delay Current Setting.) The maximum value M1 depends on the sensor rating of the circuit breaker and is listed in Note 4 of Table 1.1.

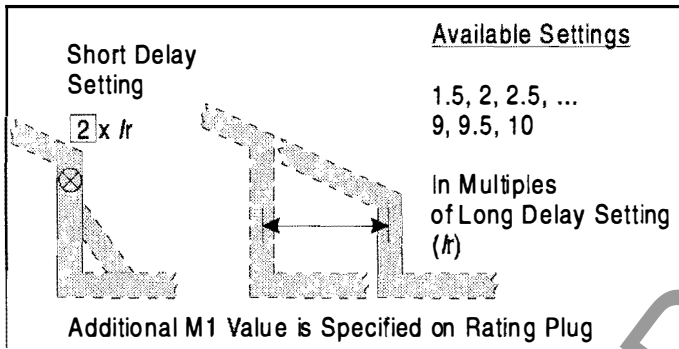

Figure 4.4 Short Delay Current Settings

**4.2.1.5 SHORT TIME Setting**

As illustrated in Figure 4.5, there are two different Short Delay Slopes: fixed and  $I^2t$ . The shape selected depends on the type of selective coordination chosen. The  $I^2t$  response curve will provide a longer time delay for current below  $8 \times I_r$  than will the FLAT response curve.

Nine FLAT and nine  $I^2t$  response time delay settings are available. The  $I^2t$  response is applicable to currents less than 8 times the ampere rating of the installed rating plug ( $I_r$ ). For currents greater than  $8 \times I_r$  the  $I^2t$  response reverts to the FLAT response.

**NOTE:** Also see Section 3.4, Zone Interlocking.

**4.2.1.6 INST PU Setting**

There are at least 18 available Instantaneous Current Settings, as illustrated in Figure 4.6. The value that M1 has depends upon the sensor rating of the circuit breaker and is specified both on the rating plug label and on the applicable time-current curves referenced in Section 9.2. The Instantaneous Pickup is based on the plug ( $I_n$ ) rating.

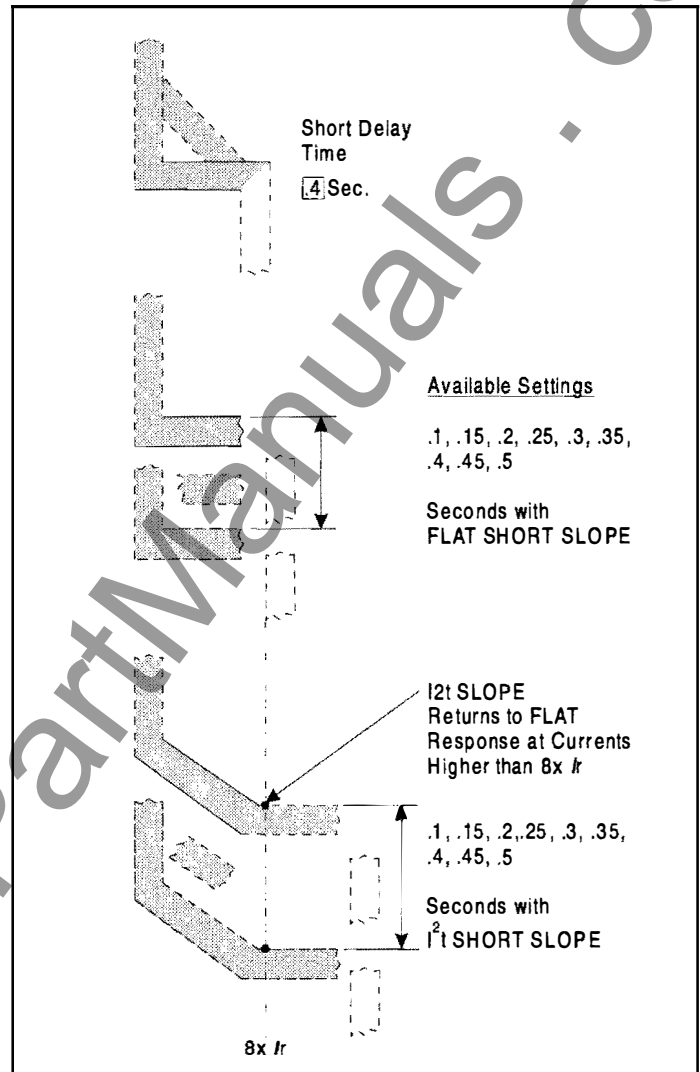

Figure 4.5 Short Delay Time Settings

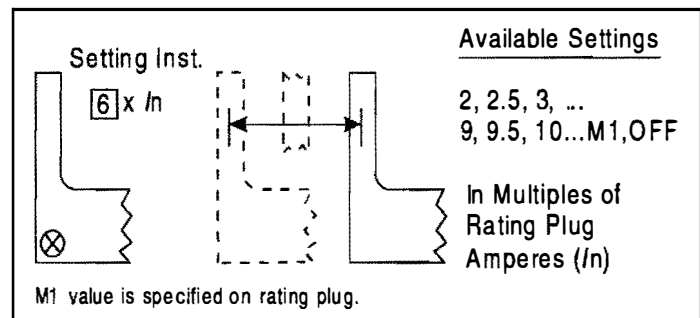

Figure 4.6 Instantaneous Current Settings

4.2.1.7 GND PU Setting

The Ground Fault Current Settings are labeled with values from .24 to 1.0x (*I<sub>n</sub>*) in 0.01 increments (see Figure 4.7). The ANSI/UL models are limited to 1200A, as shown in Table 1.1. The IEC-EF model Earth Pickup range is 0.10 to 1.0x (*I<sub>n</sub>*) with no 1200A limitation. External control power is required to insure earth fault tripping for fault currents and earth fault setting less than .24 per unit.

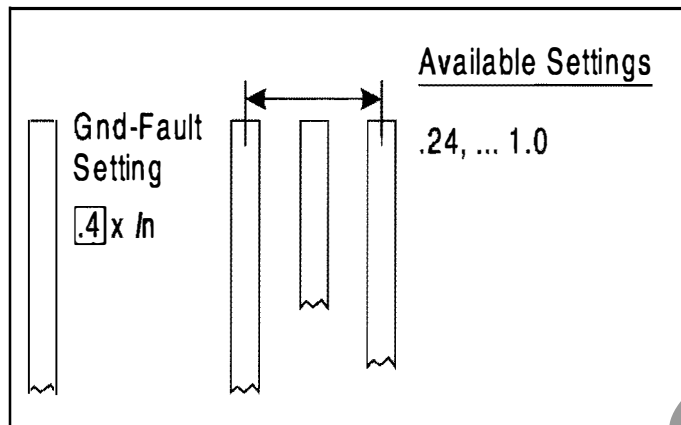

Figure 4.7 Ground Fault Current Settings

4.2.1.8 GROUND TIME Setting

As illustrated in Figure 4.8, there are two different Ground Fault Slopes: fixed time (FLAT) or *I*<sup>2</sup>*t* response. The shape selected depends on the type of selective coordination chosen. The *I*<sup>2</sup>*t* response will provide a longer time delay for current below 0.625 x *I<sub>n</sub>* than will the FLAT response.

Nine Ground Time Settings for both FLAT and *I*<sup>2</sup>*t* responses for currents less than 0.625 times the ampere rating of the installed rating plug (*I<sub>n</sub>*). For currents greater than 0.625 x (*I<sub>n</sub>*) the *I*<sup>2</sup>*t* response reverts to the FLAT response.

**NOTE:** Also see Section 3.4, Zone Interlocking.

In addition to standard Ground Fault protection, the Digitrip 1150 Trip Unit also has a GROUND FAULT MEMORY function which serves to protect loads in the event of a sputtering arc to ground. Without this function, the trip unit resets each time the arc sputters, and times out all over again, so that a sputtering fault may not be detected. With

the GROUND FAULT MEMORY function, the trip unit “remembers” the sputtering ground current for up to ten (10) times the Ground Fault Time Setting. After that time, it resets automatically. The GROUND FAULT MEMORY function resets quickly; on the 0.1 second setting, for example, the function will reset in 1.0 second.

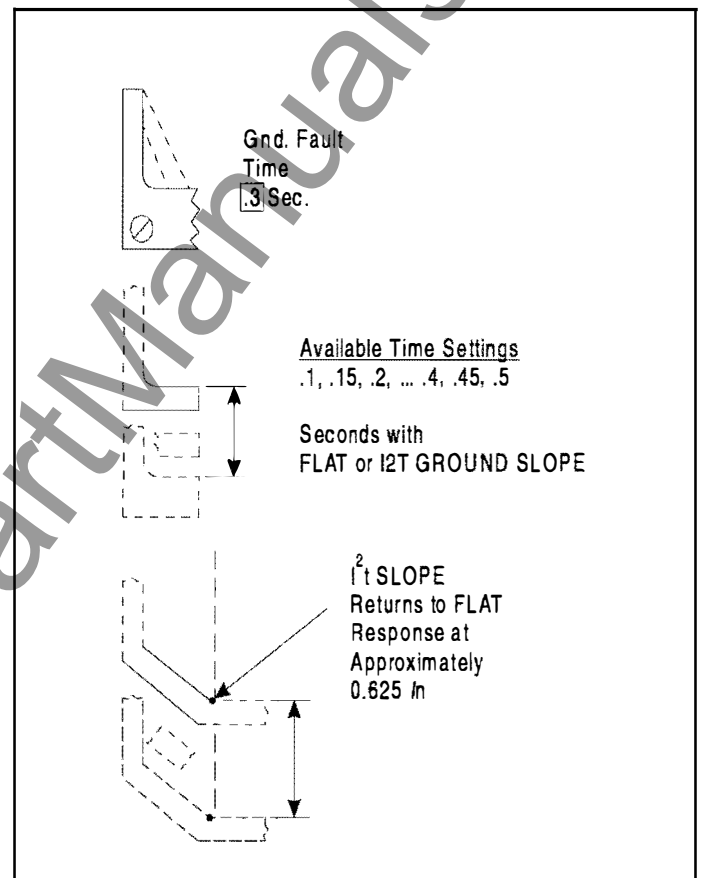

Figure 4.8 Ground Fault Time Delay Settings

4.2.2 AMP UNBALANCE, PHASE LOSS

4.2.2.1 Amp Unbalance

The Amp Unbalance trip function can be selected in the Program Settings - Program Curve menu (see Appendix D-12). It is set to OFF as a factory default. The pickup unbalance is adjustable from 5% to 25%. Once selected, an associated time delay is adjustable from 0 to 240 seconds with initial factory default of 10 seconds. A difference between Max phase and Min phase higher than

the Amp Unbalance % settings will trip with an AMPERES OUT OF BALANCE message and red Trip LED illuminated in the right corner of the Digitrip front panel. **This function does require external control power to the Digitrip unit.** To avoid unnecessary operation of this function the breaker must be carrying 55% of the  $I_r$  rating on at least one phase before it will trip via Amp Unbalance.

#### 4.2.2.2 Phase Loss

The phase loss trip function can be selected in the Program Settings - Program Curve Menu (see Appendix D-12). It is set to OFF initially as a factory default. By selecting a Time Delay of 1 to 30 seconds, SAVING will be enabled. If there exists a 75% difference between the Max phase and Min phase current and if maintained for the selected time delay, the breaker will trip with a PHASE LOSS TRIP message and red Trip LED illuminated in the right corner of the Digitrip front panel. **This function does require external power to the Digitrip unit.** To avoid unnecessary operation of this function the breaker must be carrying 55% of the  $I_r$  rating on at least one phase before it will trip via Phase Loss.

#### 4.2.3 INCOM

INCOM programming allows for five different setting options. These include address (001 – FFE in hexadecimal form), baud rate (9600 or 1200), and enabling or disabling external communications trip (EXT COMM TRIP) and external communications close (EXT COMM CLOSE). The latter two settings will allow or disallow remote control of the circuit breaker via the computer.

The fifth setting is the Digitrip 910 communications mode. When enabled, the trip unit will adopt the Digitrip 910 communications protocol. This means that while the trip unit continues to execute all Digitrip 1150 functionality, the unit only transmits those messages pertaining to the Digitrip 910 and will be identified as a 910 unit to a communicating master device.

##### 4.2.3.1 Assemblies Electronic Monitor (AEM) and Breaker Interface Monitor (BIM)

An Assemblies Electronic Monitor (AEM) can be applied in the same assembly with the circuit breakers or at a location remote from the breakers to monitor the information from any of the Digitrip 1150 Trip Units. The connections in the network are made by twisted pairs of wires. The AEM must use the Digitrip 910 communication setting. Its valid addresses are 001 through 050 decimal.

The Breaker Interface Monitor (BIM) can also be used to monitor the Digitrip 1150 trip unit. However, with BIM Firmware version 2.XX or earlier, the trip unit must be configured to be in the Digitrip 910 communications mode. Its range of acceptable addresses are 001 through 031 hexadecimal.

##### 4.2.3.2 Remote Master Computer and AEM

When desired, Digitrip 1150 Trip Units can communicate with both an Assemblies Electronic Monitor (AEM) and a remote master computer (IBM PC compatible with Cutler Hammer Inc. CONI card or MINT).

##### 4.2.3.3 INCOM Network Interconnections

INCOM sends bursts of data on a 92 to 115.2 kHz carrier at rates up to 9600 baud over twisted pair conductors to interconnect the many devices comprising the network.

The Digitrip 1150 will light the red LED shown in Figure 1.1 when transmitting on INCOM.

Recommended cable specifications:

- Cutler-Hammer Inc. cable catalog #IMPCABLE, Style #2A95705G01
- Belden 9463 cable family
- Identical Commscope or Quabbin cables

These bursts of data can be captured and used in a variety of ways depending upon the manner in which the master computer software program is written. For example, all the settings (protection and alarm) can be programmed and viewed via the master computer. Another example is that the data for the individual phase current values are available on the network, but the software must select the appropriate data, decode it and display it in a useful manner. Following an over-current trip operation, the sequence of coded data varies slightly. The cause of trip and the value and phase (or ground) current responsible for the trip are available on the network.

#### 4.2.4 Aux ReLaY

The programmable Auxiliary Relays in the Digitrip 1150 consist of Relay A (Alarming), Relay B (Blocking), and Relay C (Latching). If at least one relay function is enabled, an asterisk will appear beside the relay letter in the menu. More than one relay function can be assigned to a physical relay except for the pulse initiator selection. The selection of Relay A, B or C results in further selection of two "groups" of settings. Relay A, when selected, gives the option to enable or disable the pulse initiator and enable kVAh or kWh settings. When PULSE INITIATE is

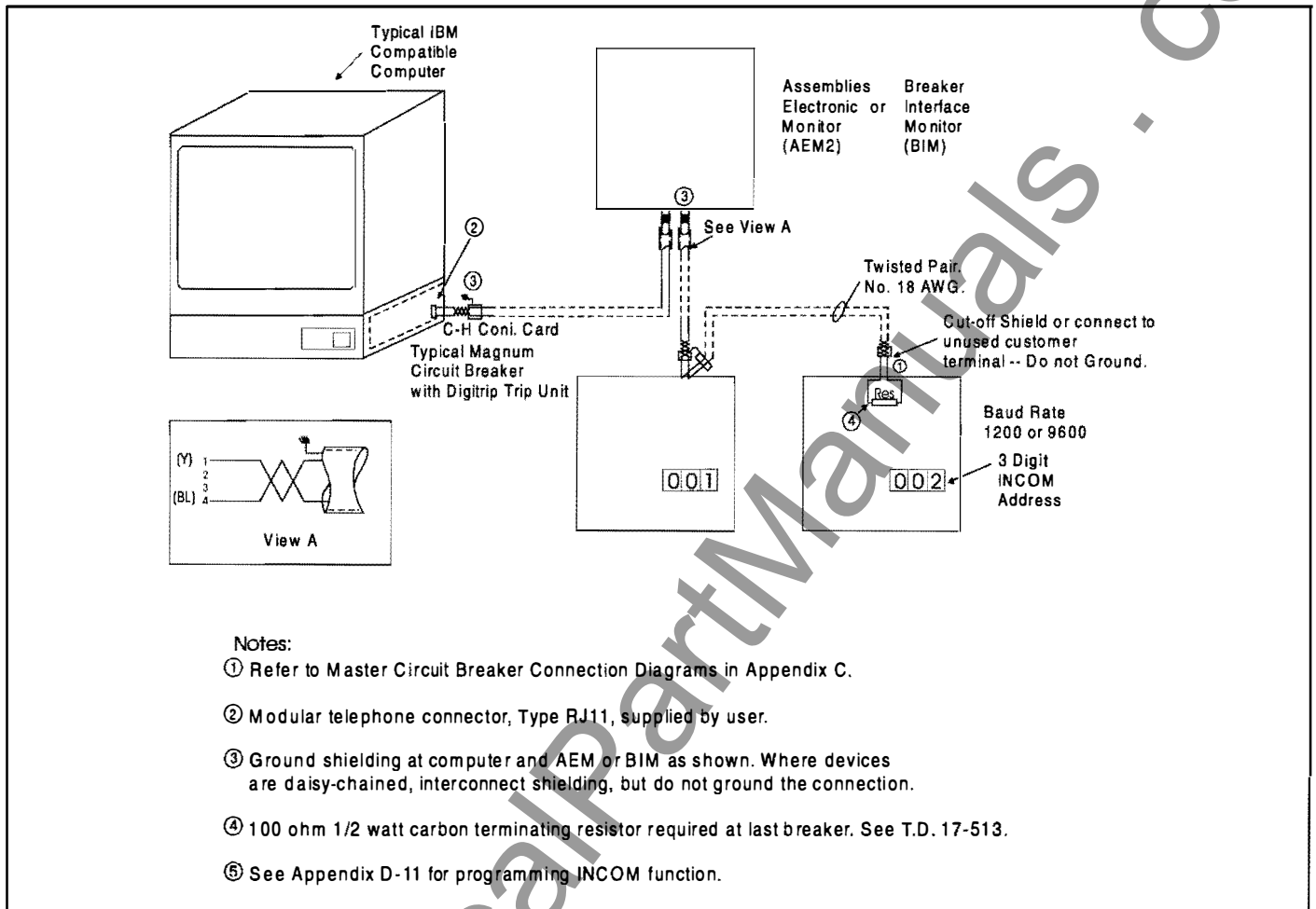

Figure 4.9 INCOM Network with Remote Master Computer and AEM or BIM

ENABLED, all groups for Relay A are skipped. When DISABLED, Groups 1, 2 may be programmed and saved for Relay A. Relays B and C do not have a PULSE INITIATE option and are only programmable for Group 1. (See Appendix D-15 and Appendix G.)

#### 4.2.5 ALARMS

Alarm programming functions the same way as other options. Ten alarm settings exist. A listing of these options and their settings can be found in Appendix D-16.

The selection of ALARM TO EventLOG setting will enable both alarm events as well as trip events to be time-stamped and placed in the three-position EventLOG.

#### 4.2.6 ACCESSORY BUS (RELAYS)

An Accessory Bus Digital Output Module is a separate device that is programmed via the Digitrip 1150. Available

module addresses are 1 through 4. Each module has four form C relay contacts numbered 1 through 4. Programmable relay functions (RLY FUNC) for each relay include AUX, ALRM, BELL, DEAD, WATCH and OFF. These options may be saved for any combination of relay functions and addresses. The Digitrip 1150 acts as a master to its Accessory Bus network and will light a green LED located in the upper right corner of the trip unit when transmitting. See Figure 1.1 and also Appendix H.

The AUX function can be used as a breaker auxiliary switch in application. BELL can be used as a breaker bell alarm trip function. ALRM (alarm) will drive the Accessory Bus relay in the same way as the assignment of Relay A. The one exception is the Accessory Bus relay will not function as a Pulse Initiator. The WATCH (watchdog) function, when programmed, can provide a status monitor of the Digitrip 1150 energizing the programmed relay when the internal diagnostics of the Digitrip are normal and will drop out if an abnormal condition exists within the Digitrip

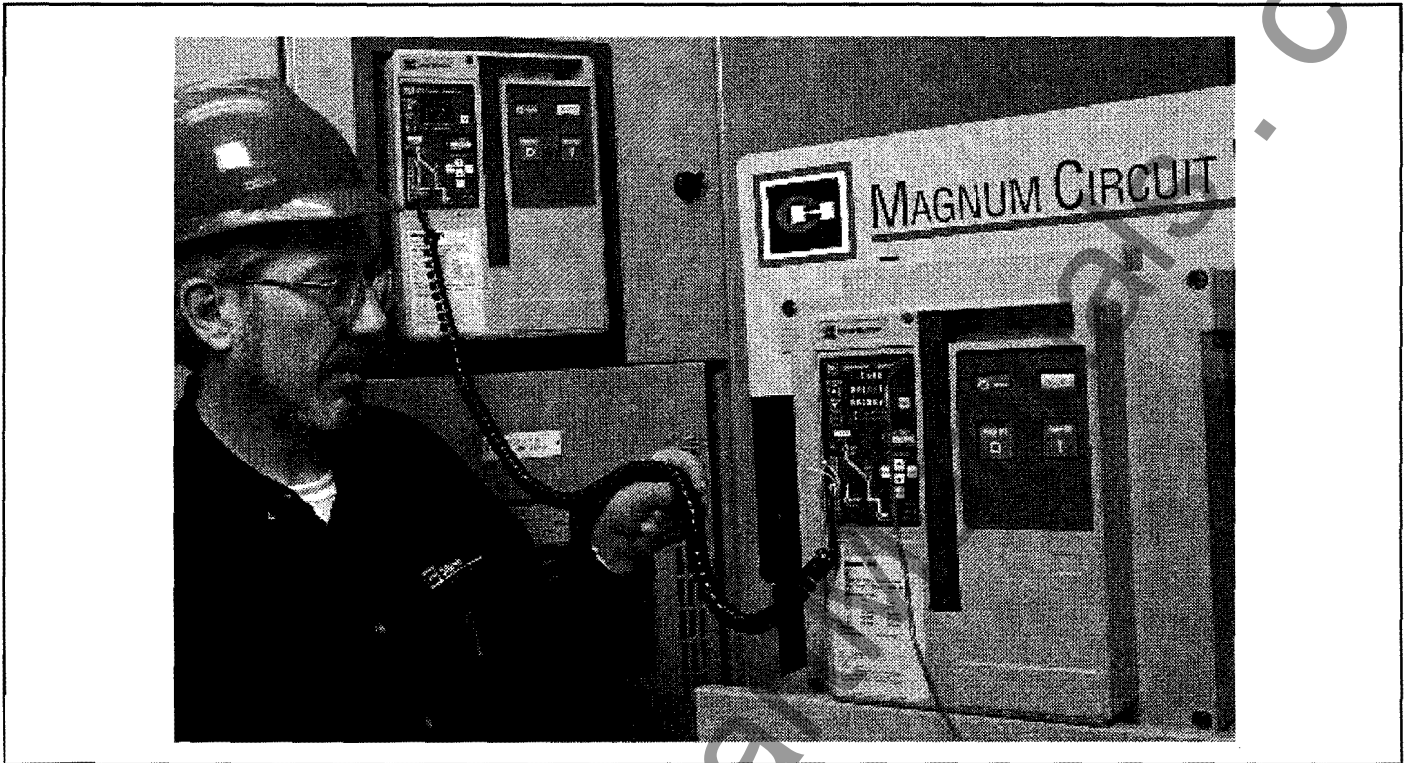

Figure 4.10 TripLink Transfer

or if auxiliary power is low voltage. The DEAD (deadman) function, when programmed, will pick up the relay if the Accessory Bus Module is communicating properly with the Digitrip 1150. It will drop out if the Accessory Bus Module is not communicating properly. This function should be assigned to the last physical Accessory Bus Module in a wiring lineup to verify the integrity of the wiring.

Accessory Bus is not available on PROTECT firmware version 8A.00.

#### 4.2.7 TripLink

TripLink is a means of transferring settings from one breaker to another. TripLink transfers all protection settings and time and date, and the breaker's circuit data. The transfer of these settings may be useful for cloning a lineup of breakers, cloning a breaker's settings for replacing the breaker with its clone for maintenance purposes, or for making common settings for a test program.

All INCOM settings including INCOM ADDRESS is transferred via TripLink. An INCOM network does require a unique address so the address may later have to be changed.

The procedure requires a TripLink cable to provide communication between breakers. The connector with the tagged end must be plugged into the breaker that will receive the settings. This cable must be plugged into the Test Kit pins on the lower left-hand corner on both breakers and both units must be powered up for the setting transfer to be successful. If power is not available, then use separate Auxiliary Power Module CAT No PRTAAPM and energize the unit by plugging keyed connector into upper right corner of the Digitrip 1150. See Figures: 1.1 and 4.10.

**Note:** A TripLink cable when installed will disconnect that unit from the INCOM communication network.

##### 4.2.7.1 Preliminary Requirements

1. Both units must be Digitrip 1150 and both must have the same Catalog (cat.) number, plug ampere rating and firmware revision for a successful transfer.
2. To send settings, the receiving breaker must be in open state and without line voltage on the breaker's main terminals.

##### 4.2.7.2 Transfer Procedure

**Note:** It is important to realize that the transfer must be performed from the RECEIVING breaker. (The breaker with the Tag.)

In the Program TripLink menu, if all preliminary requirements are met, the Digitrip 1150 display on the receiving breaker will read "THIS UNIT TO RECEIVE." Otherwise, an error message will appear reading "TripLink CONFIG ERROR" and the display will return to Program Settings menu.

If the breakers meet the preliminary requirements, the user will be prompted to "PRESS SAVE TO LEARN." When Save is pressed, settings will transfer and a "LOADING" message will appear on the display screen. Transfer will be confirmed if successful with a "TripLink TRANSFER COMPLETE" message. Otherwise, "TripLink TRANSFER ERROR" will appear on the display.

In the event of TripLink Configuration Error, check all preliminary requirements as well as the TripLink cable connections. Also ensure that transfer is being initiated and performed on the receiving breaker.

#### 4.2.8 Setting TIME

In the Digitrip 1150, dates are displayed in DD-MmmYY format (for example, 12-Mar98) and time is displayed in military-style format with hours from 0 to 23. The first screen in PGM SET\TIME is a view-only screen showing the current time setting for the unit. The View Down button changes screens to the DAY programming screen where the two digit date can be adjusted with the Edit Up or Edit Down pushbuttons. View Down then moves through the programmable three-character MONTH abbreviation, two digit YEAR selection, two digit HOURS, and two digit MINUTES which are all programmed with the Edit Up and/or Edit Down pushbuttons. Seconds are not programmable and begin at 00 when time settings are saved. Using View Up in the menu will move the user through the settings in reverse order as described above.

#### 4.2.9 Selecting DISPLAYS

Display programming options control the screens displayed in the Meter Menu. Program Display is located in the PGM SET\DISPLAY submenu. This submenu lists twenty-two programmable screens. The first screen sets metering for A, B, and C phase currents to AUTO or MANUAL. The remaining twenty-one screens meter current, power and energy and can be set to on or off, depending on user preference. Any settings turned to OFF will not be displayed when METER is selected from the Main Menu.

#### 4.2.10 General

##### 4.2.10.1 Sliding Demand

A sliding demand calculation can be chosen for either the Max kW demand or the Max kVA demand. If neither is required, the user can choose "OFF" by pressing the up/down Edit Value keys.

##### 4.2.10.2 Waveform Capture

The waveform capture function can be enabled on a 1, 5, or 10 minute basis. It can also be disabled by selecting "OFF" with the Edit Value keys. If the THD alarm setting has been enabled in the Alarms menu, the waveform capture function will automatically be set to 1 minute and the waveform capture OFF setting will not be available.

#### 4.3 View Settings (VIEW SET)

The VIEW SET menu will allow the user to view all of the settings presented in the PGM SET menus with the exception of the TripLink function. The user cannot edit or change settings in these menus.

##### 4.3.1 Firmware Menu

The Firmware menu enables the user to view the version and revision of the trip unit firmware. The protection firmware is displayed as PROTECT while DISPLAY firmware can be viewed by pressing the up/down View function keys.

#### 4.4 Meter Menu

The METER menu initially will show 6 screens of data via the factory display setup. They are phase current, neutral and ground currents (if supplied), phase voltages, forward power, power factor and frequency, and energy values. However, the program DISPLAY menu can be used to present metered data relevant to a specific customer application. There are 22 data screens selectable as listed in Appendix D-14 and D-3.

The Demand and the average, minimum and maximum current screens alternate between the data and additional information concerning the measured parameter. The min and max phase currents are actually reset as a group. See Appendix D-3. The OP COUNT screen displays breaker operation where an open/close is registered as one count. The OP COUNT can be reset also when this screen is active.

#### 4.5 Harmonic Menu

The Digitrip 1150 HARMONIC Menu provides capabilities to calculate and display the Total Harmonic Distortion (THD) for phase currents IA, IB and IC as well as IN if available.

The term THD is used to define the amount of harmonic current that the breaker is seeing or the system is experiencing in percentage of the power frequency current. This can be useful in troubleshooting to detect individual breaker current loads that could lead to system problems and early equipment failure. The equation used for calculating THD is:

$$\text{THD} = \sqrt{\frac{I_{\text{rms}}^2 - I_1^2}{I_1^2}} \times 100\%$$

Where  $I_{\text{rms}}$  is the rms current of the waveform and  $I_1$  is the rms current of the fundamental frequency.

For example, the THD calculation for a load having an equal rms value of the fundamental and third harmonic current would have a THD value of 100 percent. This would be a large value of THD and would not be typical.

In addition to individually displaying the THD for the phase currents, the Digitrip 1150 will also display the individual harmonic currents up through the 27th harmonic.

Local operation on the Digitrip to observe this data is done using the View Down pushbutton on the front panel of the Digitrip.

By selecting "HARMONIC" from the Main Menu, a waveform capture event and harmonic data calculation is accomplished locally. A second way is to automatically generate waveform capture on a 1 minute, 5 minute, 10 minute, or OFF basis by selecting "GENERAL" in the Program Settings submenu and scrolling to the "WAVEFORM CAPTURE" option. The third way is to remotely trigger the waveform capture via a PowerNet communication command. PowerNet software screens are available to show waveform capture oscillographs of each phase as well as bar graphs of the magnitudes and individual harmonics that make up the three-phase currents. See Section 4.9.

If less than 15% of the rated current is applied to the breaker, the trip unit will display three dashed lines ('- - -') for the THD and Crest Factor values since these cannot accurately be measured.

#### 4.6 Event Log

The Digitrip 1150 trip unit has the ability to record the cause, timestamp and associated current or related data for a maximum of three events. An event is defined as an alarm or trip condition experienced by the breaker. The user has the option to record only trip function events or to

record both trip and alarm functions by manipulating the Alarm to EventLOG setpoint located in the Alarms programming menu. The event data is stored in nonvolatile RAM and is maintained on a first-in, first-out basis. In the case where the Alarm to EventLOG setting is enabled, a new alarm event will replace either historic trip or historic alarm condition stored previously. See Appendix D-3.

#### 4.7 Power and Energy Parameters

Power has approximately a 1 second update rate and is shown as Forward or Reverse Power in kW units. The parameters kVA and kvar are also updated in a similar time period. Demand kW is presented as Forward or Reverse in kW units and is based on the last average - 5 minute interval. Demand kVA is also based on the last average - 5 minute interval. These parameters can be reset when this screen is in view and the Reset pushbutton action will start a new 5 minute period. Programming Alarms (kW or kVA) to exceed a threshold value will produce an Alarm. A timestamp is also provided if the Alarm to EventLOG setting is enabled.

Demand Max kW and Demand Max kVA are peak values that have been encountered since the last Reset of these parameters. A pushbutton Reset or INCOM Reset will start a new 15 minute interval. As a factory default, both kW and kVA demands are set for a "fixed" 15 minute window. The update rate for the calculation is 15 minutes. A "Sliding" window calculation is a possible setting which will calculate a continuous new Demand value and update the value if a new Max is encountered every minute. This SLIDING DEMAND setting is the first item in the GENERAL screen.

The Digitrip 1150 will display locally in kWh units of both Forward and Reverse Energy values. An additional energy parameter is kVAh. The rollover energy value is 9,999,999 for both.

The Auxiliary ReLaY A can be assigned to a Pulse Initiator function for either kVAh or kWh. When this feature is selected, ReLaY A will be dedicated for Pulse Initiator and no other relay function is possible for ReLaY A. See Appendix D-15. The Pulse Initiator provides a contact change of state to an external counter device whenever a value of  $2\% \times 3\% \times I_n$  (plug Amperes)  $\times 690V$  is exceeded. This value is based on an ANSI document.

#### 4.8 POWER QUALITY

The Digitrip 1150 in a Magnum Breaker can measure a variety of parameters relating to today's modern Power System. This data can be viewed locally or via a computer remotely in which case the data can be logged.

#### 4.8.1 Power Factor, THD and Crest Factor - CF

The System Power Factor is a real time measurement with approximately a 1 second update rate. The tolerance is the value  $\pm 0.02$ . Max PF and Min PF values are historic values that are held until Reset.

Total Harmonic Distortion (THD) of each phase and neutral (if valid) and corresponding per harmonic data up to the 27th harmonic and Crest Factor are available via a waveform capture trigger. This waveform capture trigger can be done locally by selecting HARMONIC in the Main Menu or by exceeding a THD alarm threshold programmed by the user. See section 4.8.2.

#### 4.8.2 Alarms

Alarming on low power factor can be accomplished by enabling this function in the ALARM programming screen. Any System Power Factor seen by the Digitrip 1150 less than the level programmed will initiate an alarm message on the 24 character display as well as illuminating the yellow LED and communicating to a host computer. Furthermore, the Auxiliary Relay A can be assigned to this Low PF Alarm.

The THD alarm feature is an alarm setting with a range of 10% to 30% THD that when exceeded will initiate waveform capture and also set the front panel alarm LED. The THD alarm has a 1 minute update rate. The Auxiliary Relay A can also be assigned to a THD alarm.

#### 4.9 WAVEFORM CAPTURE FEATURE

The Digitrip 1150 can respond to a command from a remote master to perform a waveform capture of phase currents IA, IB and IC, as well as waveform IN (on catalog 11LSI) or waveform IG (on catalog LSI) employing the source ground configuration). A total of 58 data points per phase per cycle is captured and can be sent to a host computer. From this data, parameters such as [THD], individual harmonics content and waveform displays can be fabricated.

There is a timer in the Digitrip unit that will limit the acceptance of a "WAVEFORM CAPTURE" software command to once per second. Three waveforms are held in a first in, first out manner in the Digitrip's volatile memory.

#### 4.9.1 Six Cycle Waveform Capture on Trip

On tripping events, the Digitrip 1150 will capture the curve waveforms to a buffer. The buffer as a waveform can be displayed on the master computer using the PowerNet software screen (Ref. I.L. 17384 for protocol and software commands). The six cycle waveform capture will typically contain one cycle of pre-interruption data and five cycles of

interruption and post-interruption data for analysis of the power system.

Note: PowerNet communications will require hardware and software specified in the Cutler-Hammer PowerNet Operations Manual and also the Digitrip 1150 Firmware must be DISPLAY VERsion 8B, REVision 02 or greater and PROTECT VERsion 8A, REVision 02 or greater. See Appendix page D-5.

#### 4.9.2 One Cycle Waveform Capture

There are two methods of obtaining a one cycle waveform capture from the Digitrip 1150. One method is via the PowerNet software to manually request a waveform capture. The second way is to trigger a waveform capture via an Alarm condition. This is accomplished by entering the PROGRAM - ALARM screen. Enable the ALARM type of interest as well as ALARM TO EventLOG. The one cycle waveform capture of the currents IA, IB, IC and IN, if applicable, can then be displayed on the master computer for analysis. IG waveform is not displayed for residual ground application. See Appendix D-16.

### 5.0 TEST PROCEDURES

#### 5.1 General

---

#### WARNING

---

**DO NOT ATTEMPT TO INSTALL, TEST, OR PERFORM MAINTENANCE ON EQUIPMENT WHILE IT IS ENERGIZED. DEATH OR SEVERE PERSONAL INJURY CAN RESULT FROM CONTACT WITH ENERGIZED EQUIPMENT.**

**DE-ENERGIZE THE CIRCUIT AND DISCONNECT THE CIRCUIT BREAKER BEFORE PERFORMING MAINTENANCE OR TESTS.**

---

#### WARNING

---

**ANY TRIPPING OPERATION WILL CAUSE DISRUPTION OF SERVICE AND POSSIBLE PERSONAL INJURY, RESULTING IN THE UNNECESSARY SWITCHING OF CONNECTED EQUIPMENT.**

---

**! CAUTION**

---

**TESTING A CIRCUIT BREAKER WHILE IT IS IN-SERVICE AND CARRYING LOAD CURRENT IS *NOT* RECOMMENDED.**

**TESTING OF A CIRCUIT BREAKER THAT RESULTS IN THE TRIPPING OF THE CIRCUIT BREAKER SHOULD BE DONE ONLY WITH THE CIRCUIT BREAKER IN THE TEST OR DISCONNECTED CELL POSITIONS OR WHILE THE CIRCUIT BREAKER IS ON A TEST BENCH.**

### 5.2 When to Test

Testing prior to start-up can best be accomplished with the breaker out of its cell or in the Test, Disconnected, or Withdrawn (or Removed) cell positions.

**NOTE:** Since time-current settings are based on desired system coordination and protection schemes, the protection settings selected and preset in accordance with Section 4 should be reset to their as-found conditions if altered during any routine test sequence.

### 5.2.1 Self Testing

Prior to any self testing, the plexiglass cover will need to be removed.

The Digitrip 1150 provides means via the TEST selection in the main menu to conduct Phase (PH) or Ground (GND) (if applicable) testing in either a TRIP or NON-TRIP mode. See Appendix D-20 for pushbutton sequence to conduct the testing. To conduct this testing as well as viewing setting (if applicable) a small Auxiliary Power Module, CAT No. PRTAAPM, is available for these functions.

This Module is an intermittent duty device that is powered via 120 VAC, 50/60 Hertz and will plug into the upper right corner of the product. See Figure 1.1.

When performing a trip unit self test in TRIP mode, **tripping** of the circuit breaker and **activation** of the associated Alarm or Accessory Bus relays can occur. This is important to consider before initiating a test, since a breaker or relay action can initiate other equipment responses in the system even if the breaker is in test position of a switchgear cell. The one exception to this is the Ground Trip self test function of the LSIA style unit. A Ground TRIP test will not actually trip the breaker but will only provide alarm display information and alarm relay operation (if enabled).

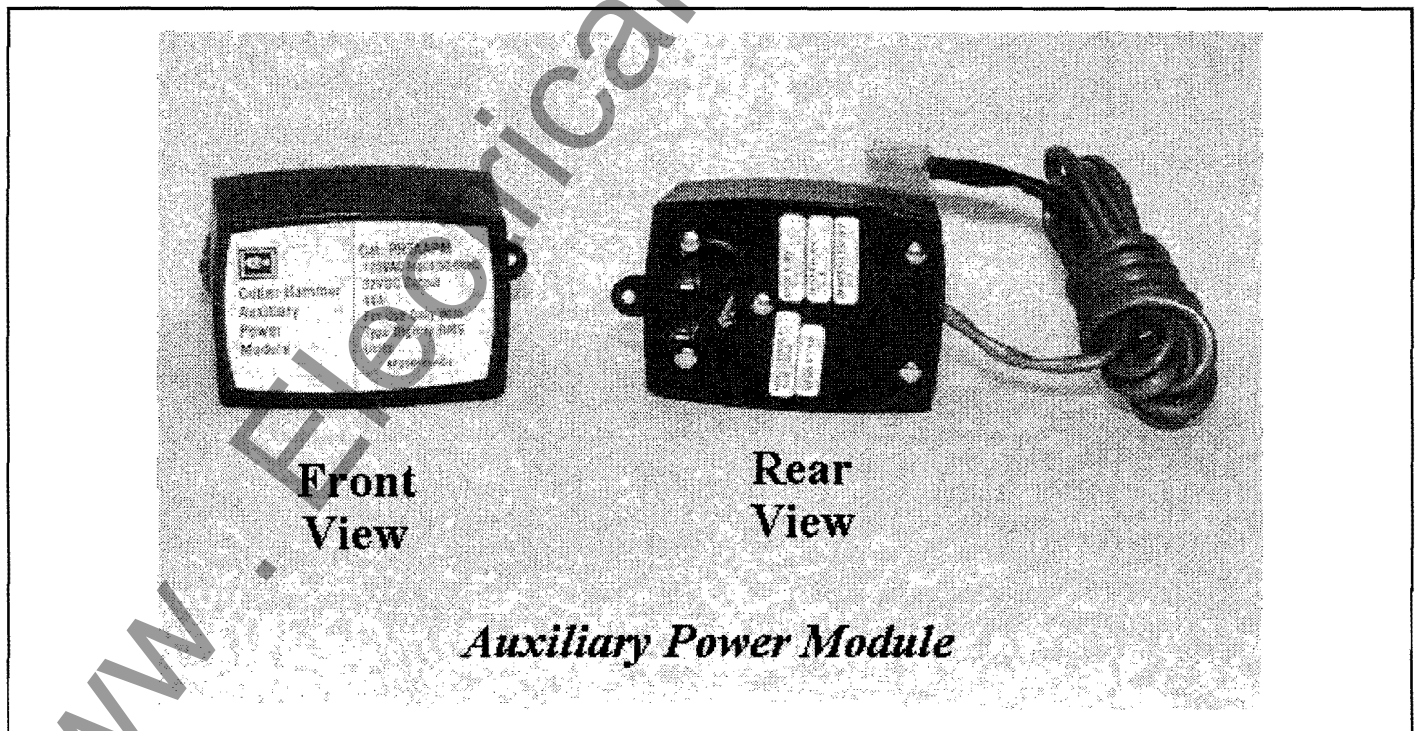

Figure 5.1 Auxiliary Power Module

In the NON-TRIP mode of self test, the breaker trip function and any associated relay will not operate when test alarm or test trips occur. The front panel indicating LED will light as well as display alarm/trip cause information.

The Self Test function cannot be entered if an alarm is already present. This alarm will need to be cleared before any self testing can be conducted. The self test function will terminate if any of the following conditions occur after the start of testing:

1. Any real Phase current exceeds an alarm setting
2. Any real Ground current exceeds 0.1 per unit.
3. If real Phase current exceeds  $1 \times (I_r)$  while conducting a NON-TRIP test.
4. If real Phase current exceeds  $0.5 \times (I_r)$  while conducting a TRIP test.

**5.2.2 Functional Field Testing**



**CAUTION**

**PERFORMING TESTS WITHOUT THE CUTLER-HAMMER-APPROVED TEST KIT MAY DAMAGE THE DIGITRIP UNIT.**

Use the test receptacle to verify a functional load test of a major portion of the electronic circuitry of the Digitrip and the mechanical trip assembly of the breaker. The testing can determine the accuracy of the desired trip settings by performing Long Delay, Short Delay, and Ground Fault functional tests. The Cutler-Hammer-approved test kit is listed below.

Model	Test Kit
Digitrip 1150	Test Kit (140D481G02R, 140D481G02RR, 140D481G03, or G04) with Test Kit Adapter 8779C02G04

The test port is located on the front left-hand corner of the DT1150 units (see Figure 1.1). To access the port, remove the plexiglass cover from the front of the circuit breaker. Using a small screwdriver, gently pry up on the test port cover to remove this item.

The test kit authorized by Cutler-Hammer for use with the Digitrip units plugs into the test port of the unit and provides a secondary injection test that simulates currents from the current transformers. Existing test kits, styles 140D481G02R, 140D481G02RR, 140D481G03 or G04, along with the Magnum Test Kit Adapter 8779C02G04, can be used to test the trip unit and breaker.

**5.3 Performance Testing for Ground Fault Trip Units**

**5.3.1 Code Requirements**

The NEC, under Article 230-95-C, requires that any ground fault protection system be performance tested when first installed. Conduct tests in accordance with the approved instructions provided with the equipment. Make a written record of this test and make the results available to the authority having inspection jurisdiction.

**5.3.2 Standard Requirements**

As a follow-up to the basic performance requirements stipulated by the NEC, UL Standard No. 1053 requires that certain minimum instructions must accompany each groundfault protection system. These statements (Section 5.4.3), plus a copy of the record forms (Figures 8.1, 8.2, and 8.3), are included as part of this Instructional Leaflet.

**5.3.3 General Test Instructions**

The interconnected system must be evaluated only by qualified personnel and in accordance with the equipment assembler's detailed instructions.

To avoid improper operations following apparently correct simulated test operations, the polarity of the neutral sensor connections (if used) must agree with the equipment assembler's detailed instructions. Where a question exists, consult the specifying engineer and/or equipment assembler.



**WARNING**

**PERSONAL INJURY CAN OCCUR WHEN WORKING ON POWER SYSTEMS. ALWAYS TURN OFF POWER SUPPLYING BREAKER BEFORE CONDUCTING TESTS. TEST OUT OF THE CELL, IF POSSIBLE. THERE IS A HAZARD OF ELECTRICAL SHOCK OR BURN WHENEVER WORKING IN OR AROUND ELECTRICAL EQUIPMENT.**

Verify the grounding points of the system using high-voltage testers and resistance bridges to ensure that ground paths do not exist that could bypass the sensors.

Use a low-voltage (0 to 24 volt), high-current, AC source to apply a test current of 125 percent of the Digitrip unit pick-up setting through one phase of the circuit breaker. This should cause the breaker to trip in less than 1 second and operate the alarm indicator. Reset the Digitrip and then reclose the breaker. Repeat the test on the other two phases (see Figure 5.2).

Apply the same current as described above through one phase of the breaker, returning through the neutral sensor. The breaker should not trip, and the alarm indicator should not operate. Repeat the test on the other two phases.

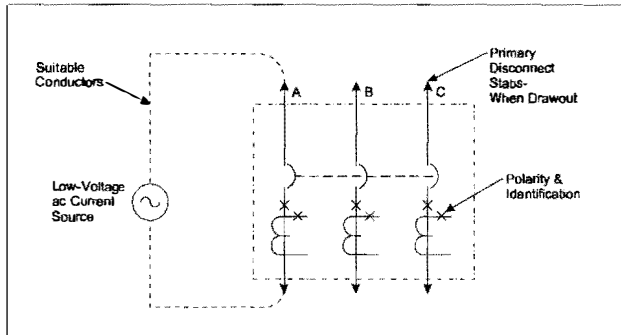

Figure 5.2 Connection Details for Conducting Single Pole, Single Phase Current Tests with the Breaker Removed from the Cell

Apply the same current as described above through any two phases of the breaker. The breaker should not trip. Repeat the test using the other two combinations of breaker phases (see Figure 5.3)

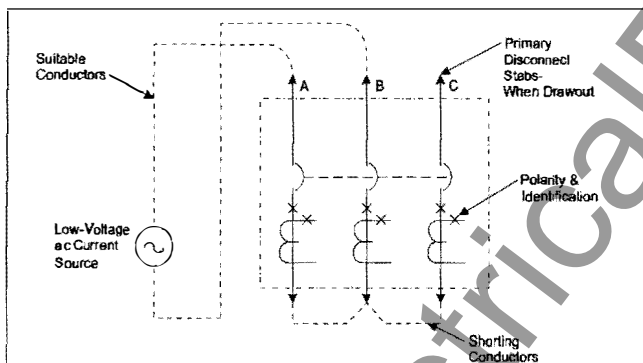

Figure 5.3 Connection Details for Conducting Single Phase Current Tests with the Breaker Removed from the Cell

### ! CAUTION

**RESTORE ALL TEMPORARY CONNECTIONS MADE FOR THE PURPOSE OF CONDUCTING TESTS TO PROPER OPERATING CONDITIONS BEFORE RETURNING THE BREAKER TO SERVICE.**

Record the test results on the test form provided with the equipment (Figure 8.3).

## 6.0 BATTERY

### 6.1 General

The battery plays no part in the protection function of the trip unit.

As indicated in Figure 3.1, the battery is provided to flash and power the red LED indication on the mimic curve. The battery is located under the rating plug door. A battery test pushbutton and a green Battery Test LED are also provided.

A second function of the battery is to provide backup power for the clock chip in the unit. The clock is used to timestamp trip and alarm events.

On initial installation of the circuit breaker, pull out the insulating tab with a quick pull. See Figure 6.1. This will activate the battery. Check the battery status using the Battery Test pushbutton.

### 6.2 Battery Test

The battery is a long-life, lithium, camera-type unit. Check the status of the battery at any time by pressing the Battery Test pushbutton and observing the green LED. If the Battery Test LED does not light green, replace the battery. The condition of the battery has no effect on the protection function of the trip unit. Even with the battery removed, the unit will still trip the breaker in accordance with its settings. However, without the battery, the Cause of Trip LED will not be lighted red if auxiliary power is lost to the Digitrip. If the battery is replaced, one or more of the Cause of Trip LEDs may be illuminated. Push the red Reset/Battery Test button to turn off the indicators; the trip unit will be ready to indicate the next cause of trip.

### 6.3 Battery Installation and Removal

The 3-volt lithium cell battery (see Figure 6.1) is easily removed and replaced. The battery is located in the cavity adjacent to the rating plug mounting screw, but is not part of the rating plug. Insert a small screwdriver at the left side of the rating plug, and to the left of the word OPEN, to open the rating plug door. Remove the old battery by pulling up on the removal tab that wraps under the battery cell. When inserting the new cell, pay special attention to ensure that the proper polarity is observed. The main body of the battery is the positive (+) side.

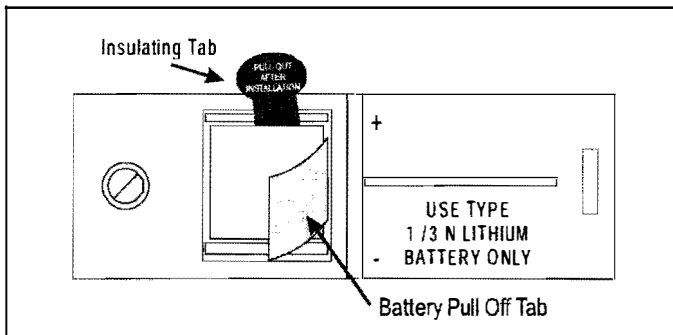

Figure 6.1 Digitrip Battery

**NOTE:** The battery can be replaced at any time, even while the circuit breaker is in-service, without affecting the operation of the circuit breaker or its protection functions.

**CAUTION**

**EXERCISE CARE WHEN REPLACING THE BATTERY TO ENSURE THAT THE CORRECT POLARITIES ARE OBSERVED. POLARITY MARKINGS ARE SHOWN ON THE RATING PLUG WHEN THE HINGED COVER IS OPEN. ACCIDENTALLY INSTALLING THE BATTERY IN THE REVERSE DIRECTION WILL NOT HARM EITHER THE TRIP UNIT OR THE BATTERY, BUT WILL DEFEAT THE FUNCTION OF THE BATTERY.**

The replacement battery should be the same type as that already in the trip unit or an equivalent. Acceptable 3.0 volt lithium batteries may be obtained from the following companies:

<b>Company</b>	<b>Model</b>
VARTA Batteries, Inc. 300 Elmsford Boulevard Elmsford, N.Y. 10523 914-592-2500 (www.varta.com)	CR 1/3N
Duracell, Inc. Berkshire Corporate Park Bethel, CT 06801 1-800-551-2355 (www.duracell.com)	DL 1/3N
Sanyo Energy Corporation 2055 Sanyo Avenue San Ysidro, CA 92173 619-661-6620 (www.sanyo.co.jp)	CR 1/3N

**7.0 FRAME RATINGS (SENSOR RATINGS AND RATING PLUGS)**

The frame rating of a circuit breaker is the maximum RMS current it can continuously carry. The maximum short-circuit current rating of the circuit breaker is usually related to the frame rating as well.

A current value, (*I<sub>n</sub>*), that is less than the full frame rating may be chosen to be the basis for the coordination of the protection function of the breaker without affecting its short-circuit current capability. For the Digitrip 1150, this is implemented by changing the current sensors and the corresponding rating plug. These sensors and rating plugs are available in kit form.

The current sensor rating is the maximum current the circuit breaker can carry with the specified current sensors installed. The sensor rating can be the same or less than the frame rating, but not greater.

This value, (*I<sub>n</sub>*), is the basis for the trip unit current settings:

1. The Instantaneous and Ground Current Settings (if provided) are multiples of (*I<sub>n</sub>*) (see Sections 4.2.1.6 and 4.2.1.7).
2. The Long Delay Current Setting, (*I<sub>r</sub>*), is a fractional multiple of (*I<sub>n</sub>*): Long Delay Current Setting = (*I<sub>r</sub>*) = LD x (*I<sub>n</sub>*) (see Section 4.2.1.2).
3. The Short Delay Current Setting is a multiple of (*I<sub>r</sub>*): Short Delay Current Setting = SD x (*I<sub>r</sub>*) = SD x [LD x (*I<sub>n</sub>*)] (see Section 4.2.1.4).

**CAUTION**

**BEFORE YOU FIT THE RATING PLUG INTO THE TRIP UNIT, BE SURE TO CHECK THAT THE SENSOR RATING MATCHES THAT PRINTED ON THE RATING PLUG DOOR. INSTALLING A RATING PLUG THAT DOES NOT MATCH THE SENSOR RATING CAN PRODUCE SERIOUS MISCOORDINATION AND/OR FAILURE OF THE PROTECTION SYSTEM.**

**NOTE:** Rating plugs from Digitrip models 210, 500, or 510 **CANNOT** be used with Digitrip 1150 Units.

## 8.0 RECORD KEEPING

Use the forms shown in Figures 8.1 and 8.2 for record keeping. Fill in these forms, giving the indicated reference information and initial time-current trip function settings. If desired, make a copy of the form and attach it to the interior of the breaker cell door or another visible location. Figure 8.3 provides a place for recording test data and actual trip values.

Ideally, sheets of this type should be used and maintained by those personnel in the user's organization that have the responsibility for protection equipment.

## 9.0 REFERENCES

### 9.1 Magnum and Magnum DS Circuit Breakers

I.B. 2C12060	Magnum DS Breaker Instructions
I.B. 2C13060	Magnum I. Breaker Instructions
4A36346	Zone Interlocking Application with Non-Magnum Breakers

### 9.2 Time-Current Curves

The Time-Current Curves are listed below for particular trip unit models. All protection function time-current settings should be made following the recommendations of the specifying engineer in charge of the installation.

70C1041	Digitrip 1150/1150i	Ground (Earth) Trip
70C1043	Digitrip 1150/1150i	Instantaneous Trip
70C1034	Digitrip 1150/1150i	I <sup>2</sup> t Long Time Trip
70C1035	Digitrip 1150/1150i	I <sup>4</sup> t Long Time Trip
70C1038	Digitrip 1150 IEEE	Moderately Inverse
70C1039	Digitrip 1150 IEEE	Very Inverse
70C1040	Digitrip 1150 IEEE	Extremely Inverse
70C1031	Digitrip 1150i IEC-A	Normal Inverse
70C1032	Digitrip 1150i IEC-B	Very Inverse
70C1033	Digitrip 1150i IEC-C	Extremely Inverse

<b>DIGITRIP</b>				
TRIP FUNCTION SETTINGS				
Circuit No./Address		Breaker Shop Order Reference		
PER UNIT MULTIPLIERS				
Rating Plug Amperes ( <i>h</i> )		<i>k</i> Continuous Ampere Rating = LDS x <i>h</i>		
Trip Function	Per Unit Setting	Multi	Ampere Equivalent Setting	Time Delay
Inst.		<i>h</i>		X
Long Delay		<i>h</i>		Sec.
Short Delay		<i>k</i>		Sec.
Ground Fault		<i>h</i>		Sec.
Date _____		By _____		

Figure 8.1 Typical Trip Function Record Nameplate

DIGITRIP				
AUTOMATIC TRIP OPERATION RECORD				
Circuit No./Address	Breaker Shop Order Reference			
Trip Function	Settings Reference			
	Factory	Rev. 1	Rev. 2	Rev. 3
Curve Type	LSIG*			
Slope	I2T			
I <sub>r</sub> = Long PU x I <sub>n</sub>	1.0			
Long Time	4s			
Long Memory	ON			
Short Slope	FLAT			
Short PU x I <sub>r</sub>	3.0			
Short Time	0.3s			
Inst PU x I <sub>n</sub>	4			
Ground* Slope	FLAT			
Ground* PU x I <sub>n</sub>	0.4 or 0.24			
Ground* Time	0.3s			
* if supplied				
Date of Trip	Trip Mode Indicator	Setting Ref.	Setting Change Made	Investigated By

Figure 8.2 Automatic Trip Operation Record

<b>GROUND FAULT TEST RECORD FORM</b>			
Ground Fault Test Record should be retained by those in charge of the building's electrical installation in order to be available to the authority having jurisdiction.			
<b>Test Date</b>	<b>Circuit Breaker Number</b>	<b>Results</b>	<b>Tested by</b>

Figure 8.3 Typical Performance Test Record Form

---

## NOTICE

---

**THE PROVISION FOR ZONE INTERLOCKING IS STANDARD ON MAGNUM CIRCUIT BREAKERS WITH DIGITRIP 1150 TRIP UNITS FOR SHORT TIME AND GROUND FAULT FUNCTIONS. THE APPROPRIATE JUMPER TO TERMINAL B8 AND B9 MUST BE ADDED ON THE BREAKER IF ZONE INTERLOCKING IS NOT DESIRED OR IF FIELD TESTING IS DESIRED.**

### APPENDIX A Zone Interlocking Examples

#### **CASE 1: There is no Zone Selective Interlocking. (Standard time delay coordination is used.)**

Assume that a ground fault of 2000 Amperes occurs and refer to Figure A.1.

##### *Fault at location 3*

The branch breaker will trip, clearing the fault in 0.1 seconds.

Main and feeder trip units will also begin to time out and, in the event that the branch breaker does not clear the fault, the feeder breaker will clear the fault in 0.3 seconds (as above). Similarly, in the event that the feeder breaker does not clear the fault, the main breaker will clear the fault in 0.5 seconds (as above).

##### *Fault at location 2*

The feeder breaker will trip, clearing the fault in 0.3 seconds.

The main trip unit will also begin to time out and, in the event that the feeder breaker Z2 does not clear the fault, the main breaker will clear the fault in 0.5 seconds (as above).

##### *Fault at location 1*

The main breaker will trip, clearing the fault in 0.5 seconds.

#### **CASE 2: There is Zone Selective Interlocking.**

Assume a ground fault of 2000 Amperes occurs and refer to Figure A.1.

##### *Fault at location 3*

The branch breaker trip unit will initiate the trip in 0.045 seconds to clear the fault and the branch will send a

restraint signal to the feeder trip unit; the feeder will send a restraint interlocking signal to Z1.

Main and feeder trip units will also begin to time out and, in the event that the branch breaker does not clear the fault, the feeder breaker will clear the fault in 0.3 seconds (as above). Similarly, in the event that the feeder breaker does not clear the fault, the main breaker will clear the fault in 0.5 seconds (as above).

##### *Fault at location 2*

The feeder breaker trip unit will initiate the trip in 0.045 seconds to clear the fault and will send an interlocking signal to the main trip unit.

The main trip unit will also begin to time out and, in the event that the feeder breaker Z2 does not clear the fault, the main breaker will clear the fault in 0.5 seconds (as above).

##### *Fault at location 1*

There are no interlocking signals. The main breaker trip unit will initiate the trip in 0.045 seconds.

Figure A.2 presents a Zone Selective Interlocking connection diagram for a system with two main breakers from incoming sources and a bus tie breaker. Note that the blocking diode D1 is needed so that the feeder breakers can send interlocking signals to both the main and the tie breakers and prevent the tie breaker from sending an interlocking signal to itself.

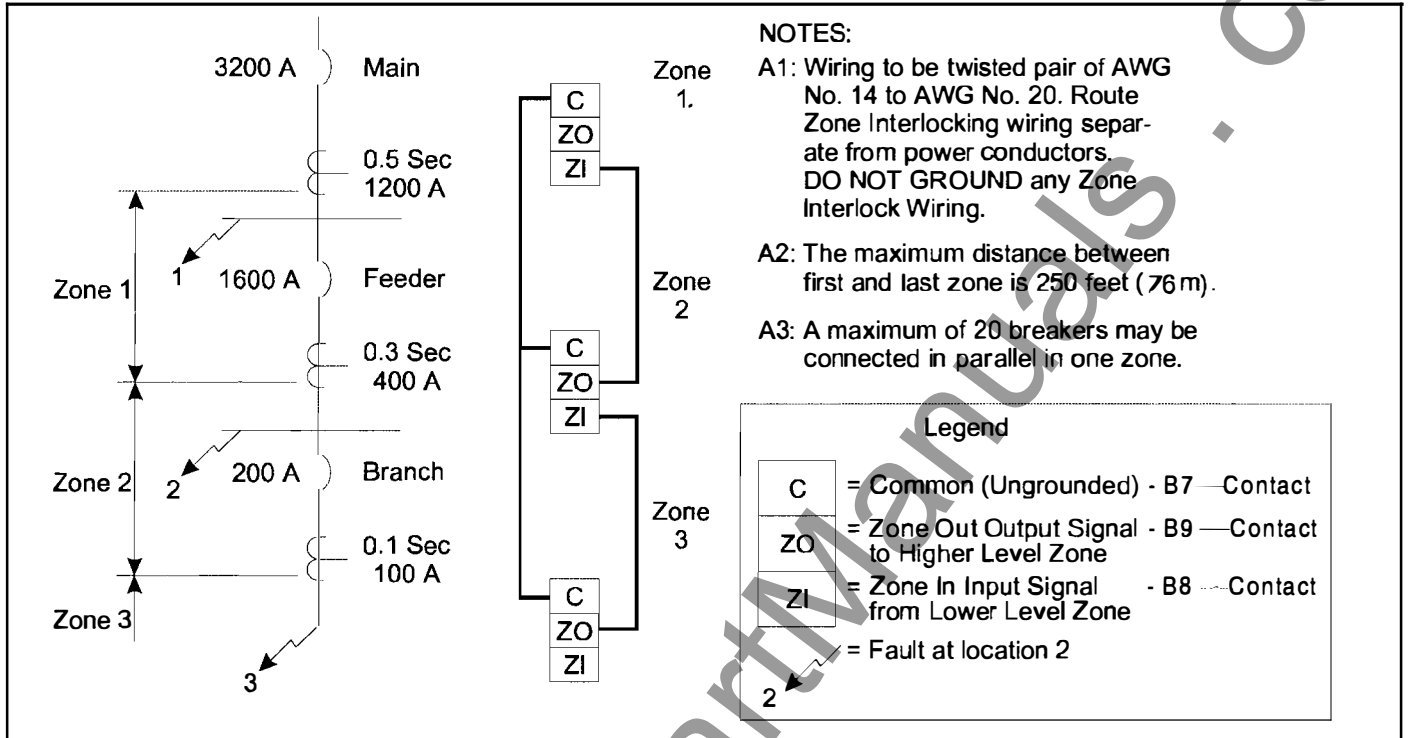

Figure A.1 Typical Zone Interlocking

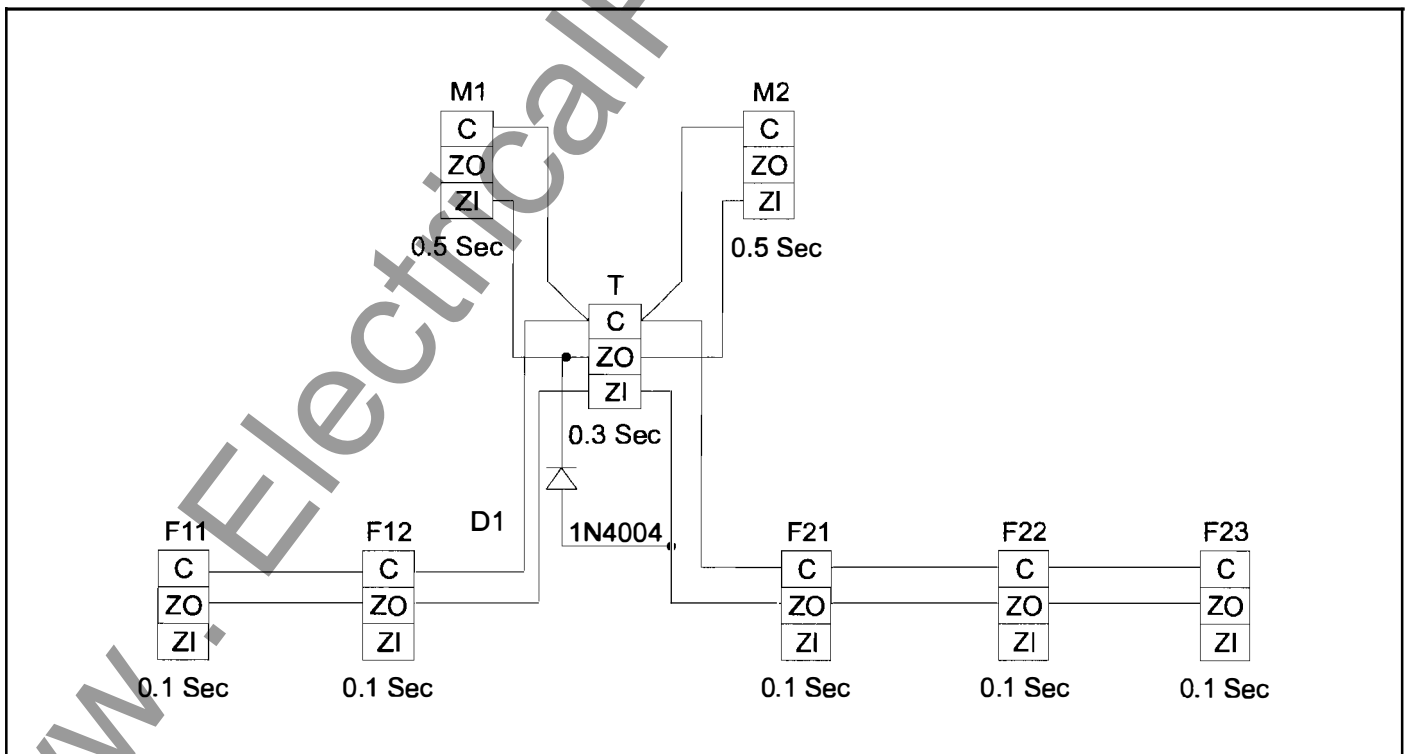
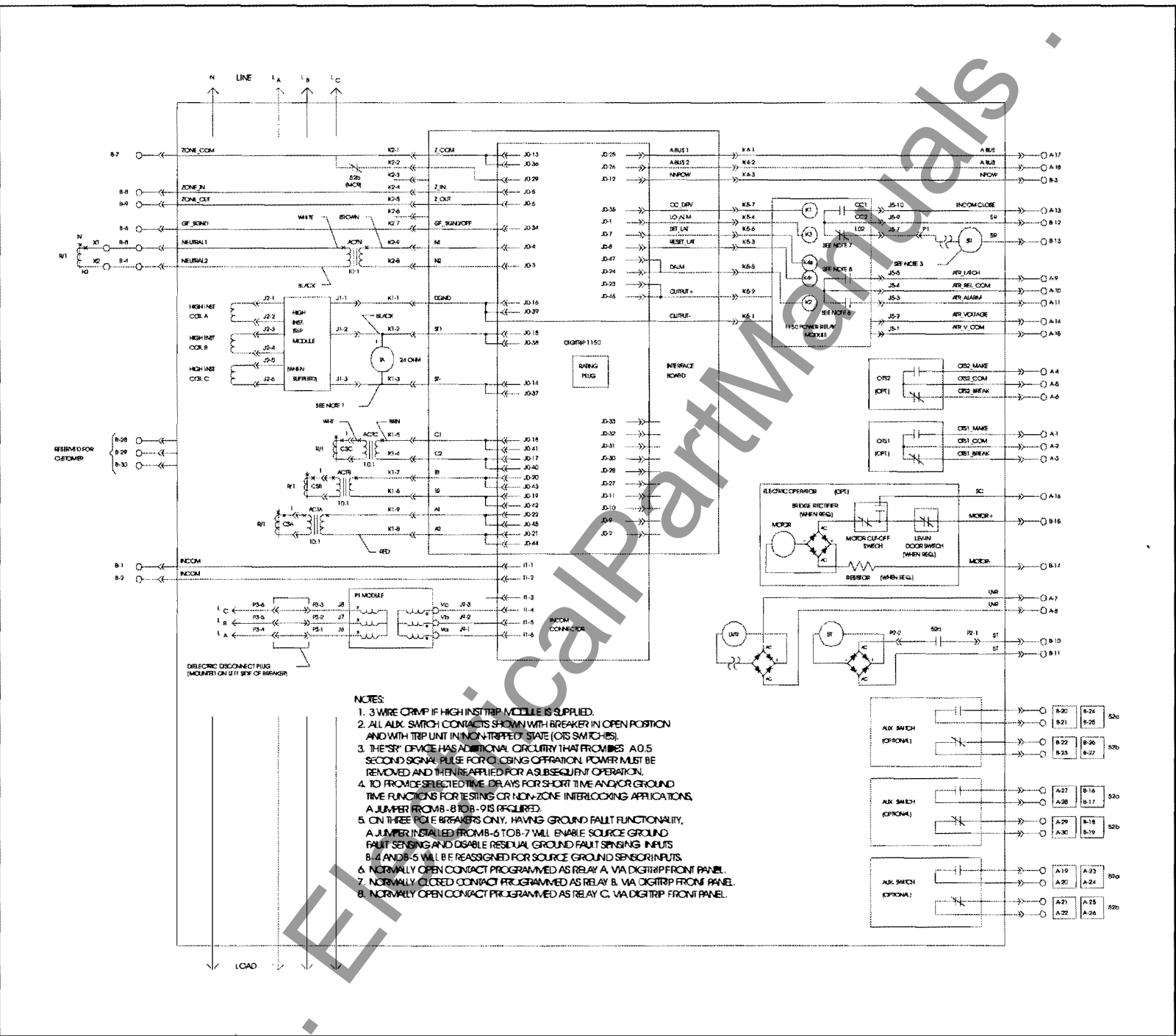

Figure A.2 Typical Zone Interlocking Connections with Two Main Breakers (M1, M2) and a Tie Breaker (T)

## Appendix B Troubleshooting Guide

Symptom	Probable Cause	Possible Solution(s)	Comments
LED display is not energized.	No auxiliary power input.		
	Wrong auxiliary power voltage.	Check voltage input terminals A14-A15.	Refer to Section 1.6.1.
As soon as current starts to flow through the breaker, it trips and the Instantaneous trip LED comes on.	Rating plug is not installed or is loose.	Install rating plug and/or check for loose connections.	
	Rating plug is open internally.	Replace rating plug.	
	Trip unit is malfunctioning.	Replace trip unit.	
LED does not come on when battery check button is pressed.	Battery installed backwards.	Install correctly.	
	Dead battery.	Replace battery.	
	Trip unit is malfunctioning.	Replace trip unit.	
Breaker trips on ground fault.	There actually is a ground fault.	Find location of the fault.	
	On 4-wire residual systems, the neutral current sensor may not have the correct ratio or be properly connected.	Check connections at terminals B4 and B5. Check that the neutral current sensor ratio matches the breaker. Check that the connections from the neutral current sensor to the breaker are not reversed. Check B6, B7 for correct programming of jumper.	See Section 2.3, Notes.
	Trip unit is malfunctioning.	Replace trip unit.	
Breaker trips too rapidly on ground fault or short delay (Zone Selective Interlocking not used).	Connection from Zout to Zin is missing.	Make connections B8 to B9.	Refer to Appendix A.
	Trip unit settings are not correct.	Change settings.	
	Trip unit is malfunctioning.	Replace trip unit.	
Breaker trips too rapidly on long delay.	Long Time Memory selected.	Disable Long Memory.	
	Trip unit settings are not correct.	Change settings. Long Time Delay setting is based on 6x $I_r$ .	

Symptom	Probable Cause	Possible Solution(s)	Comments
EEROM ALARM	Non fatal memory error	Note settings via view settings screen. Then enter Program Settings and SAVE CURRENT curve. If setpoint download is successful press Reset. Reverify settings	If alarm reappears after trying the possible solution, replace trip unit at first opportunity.
SETTINGS ERROR ALARM	Set point mismatch between Sure A and Sure B  Microcomputers	Note settings via view settings screen. Then enter Program Settings and SAVE CURRENT curve. If setpoint download is successful press Reset. Reverify settings	If alarm reappears after trying the possible solution, replace trip unit at first opportunity.  Ref. Fig. 3.1
WATCHDOG ALARM	Low line Voltage	Check input voltage for Aux Power A14, A15	See Appendix G and H.
WATCHDOG ALARM	Communication Problem Between Sure A and Sure B  Microcomputers	<ol style="list-style-type: none"> <li>1. Push Reset button.</li> <li>2. Replace unit if WATCHDOG alarm reappears or if status LED is not flashing.</li> </ol>	If alarm persists, protection (Sure A) function may still be present if STATUS LED is flashing. However, its values can not be communicated properly to the Display.  Ref. Fig. 3.1 and Section 3.2.1
CIRCUIT BREAKER DOES NOT COMMUNICATE WITH PowerNet, BIM	Firmware version 8B must be REV 02 or greater for 1150 mode communication	<ol style="list-style-type: none"> <li>1. Check for Aux Power A14, A15.</li> <li>2. Check address and board settings.</li> <li>3. Check status LED and Transmit LED.</li> <li>4. Check communication wiring B1, B2.</li> <li>5. Termination resistor missing. See Fig. 4.9.</li> </ol>	See Appendix G See section 4.2.3
CIRCUIT BREAKER DOES NOT COMMUNICATE WITH AEM	For communication with AEM use Digitrip 1150 in the 910 mode.	Same as above.	See Appendix G See section 4.2.3
NO VOLTAGE READINGS OR METER MENU	PT dielectric plug removed	<ol style="list-style-type: none"> <li>1. Breaker is backfed and open.</li> <li>2. Digitrip is not properly connected/inserted to breaker I1 connector</li> <li>3. Replace PT Module.</li> </ol>	Ref. Section 3.5.  Ref. Fig 1.2
VOLTAGE OR CURRENT OR FREQUENCY READINGS APPEAR WRONG OR VARYING	Digitrip METER needs both phase voltages and at least 20% phase A current available initially to lock in frequency	Apply both line voltage and 20% phase A current one time to setup metering.	This situation may occur on initial startup on 50 Hertz applications since breakers are typically tested in the factory at 60 Hz.



Appendix C Typical Breaker Master Connection Diagram

Appendix D Display Menu Diagrams

Appendix D Page D-1

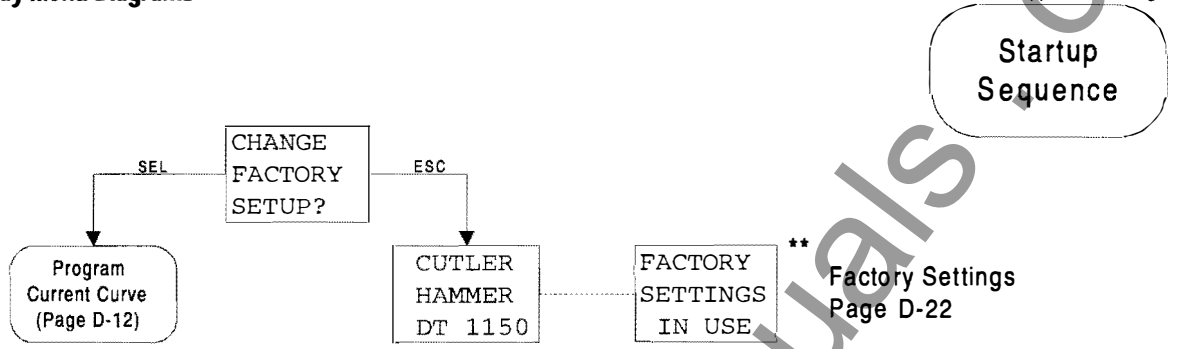

If any current curve setting (shown on pages D-12 and D-13) is changed from the Factory Settings (D-22), the unit will display the following screens on power up.



\*\* Screens will alternate back and forth for 6 seconds and then fall into the Main Menu.

Notes: **BOLDFACE** text is blinking.

Menu screens "wrap around" when using the VIEW buttons.  
 Editable values "wrap around" when using the EDIT buttons.

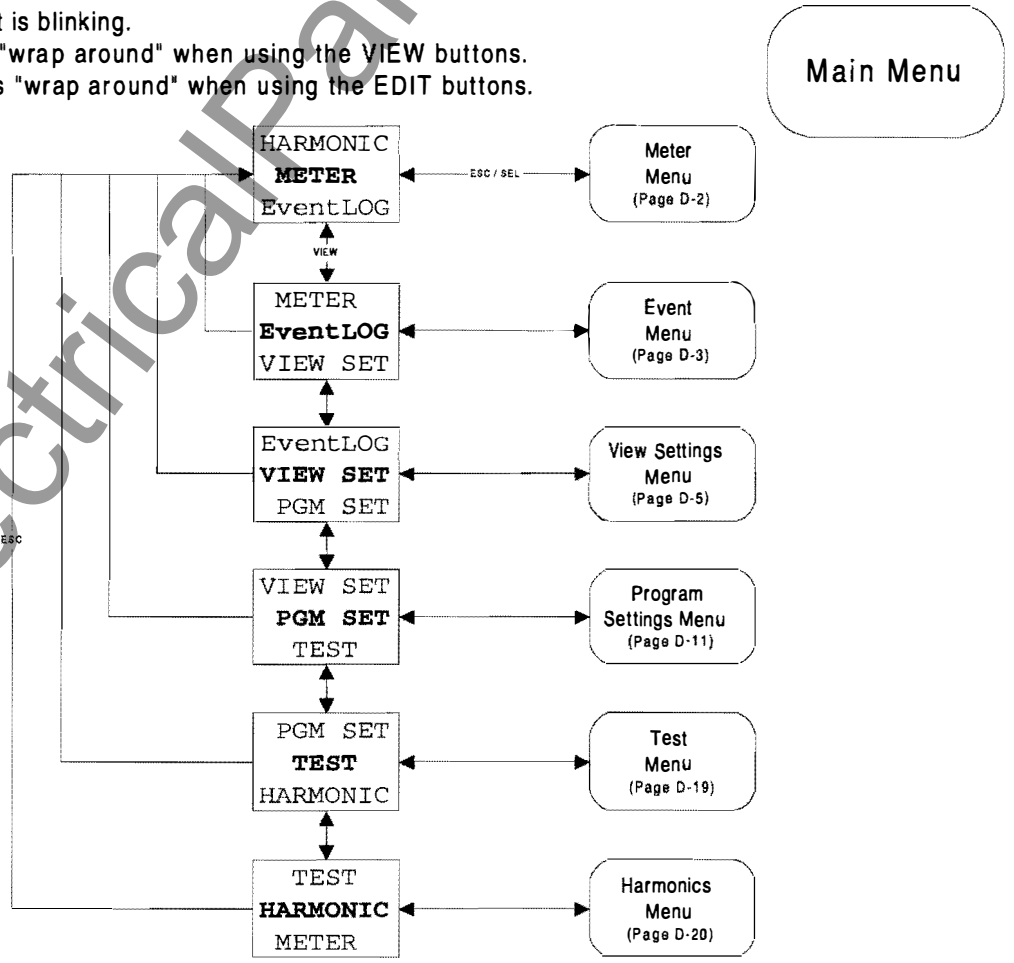

Appendix D Page D-3

(Continued from D-1)

Individual screens are only displayed if their Display Setting is set to "ON".

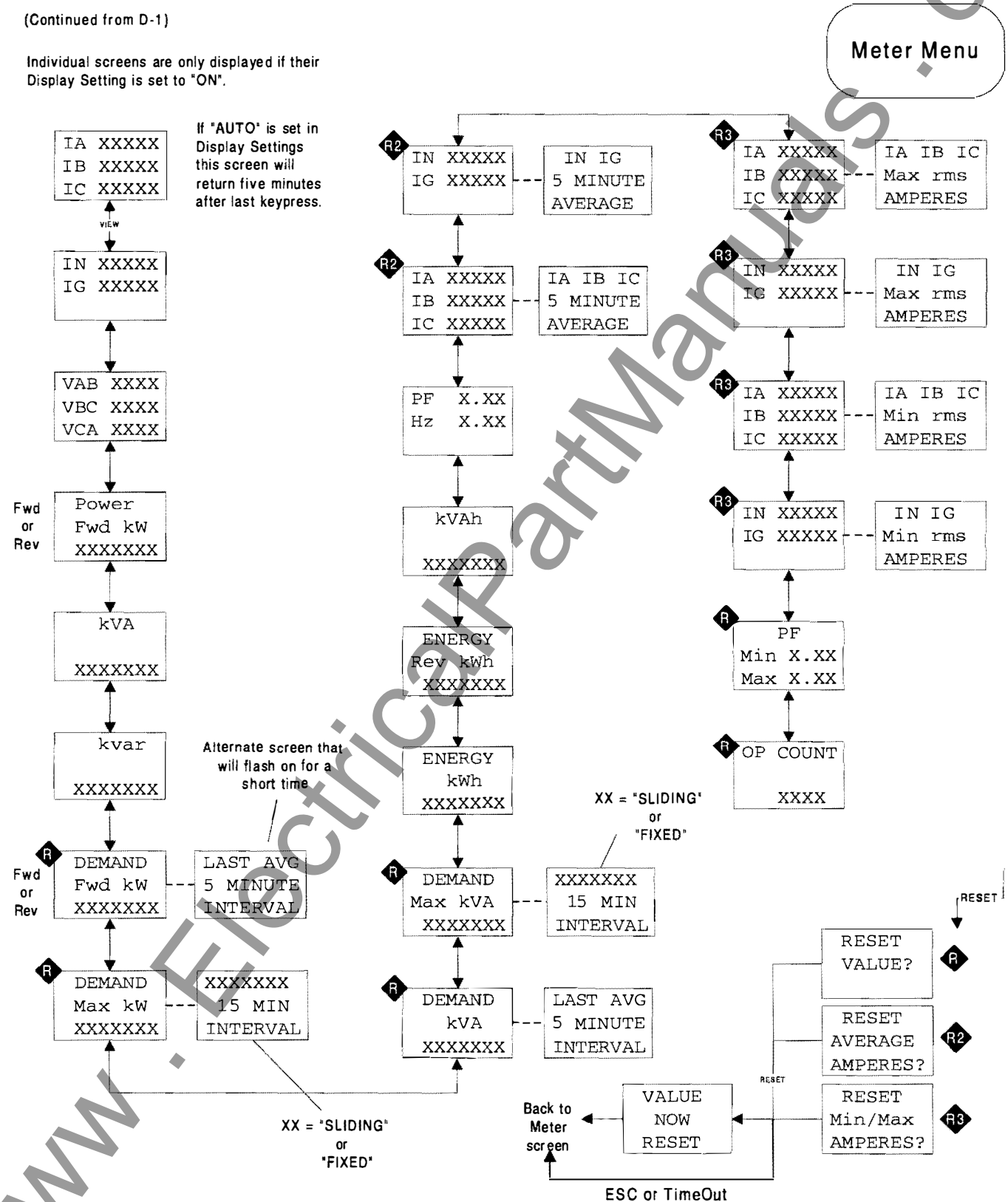

(Continued from D-1)

Event Menu

When a trip event occurs, data from the appropriate Meter Menu screens is captured and then logged for that event. The event numbering scheme (if a trip) is a first-in, first-out type, with the most recent event initially stored in Event #1. Subsequent events will then be placed in Event #2 and Event #3 followed by Event #1 again. An alarm event will be logged if "ALARM TO EventLOG" has been ENABLED (page D-16).

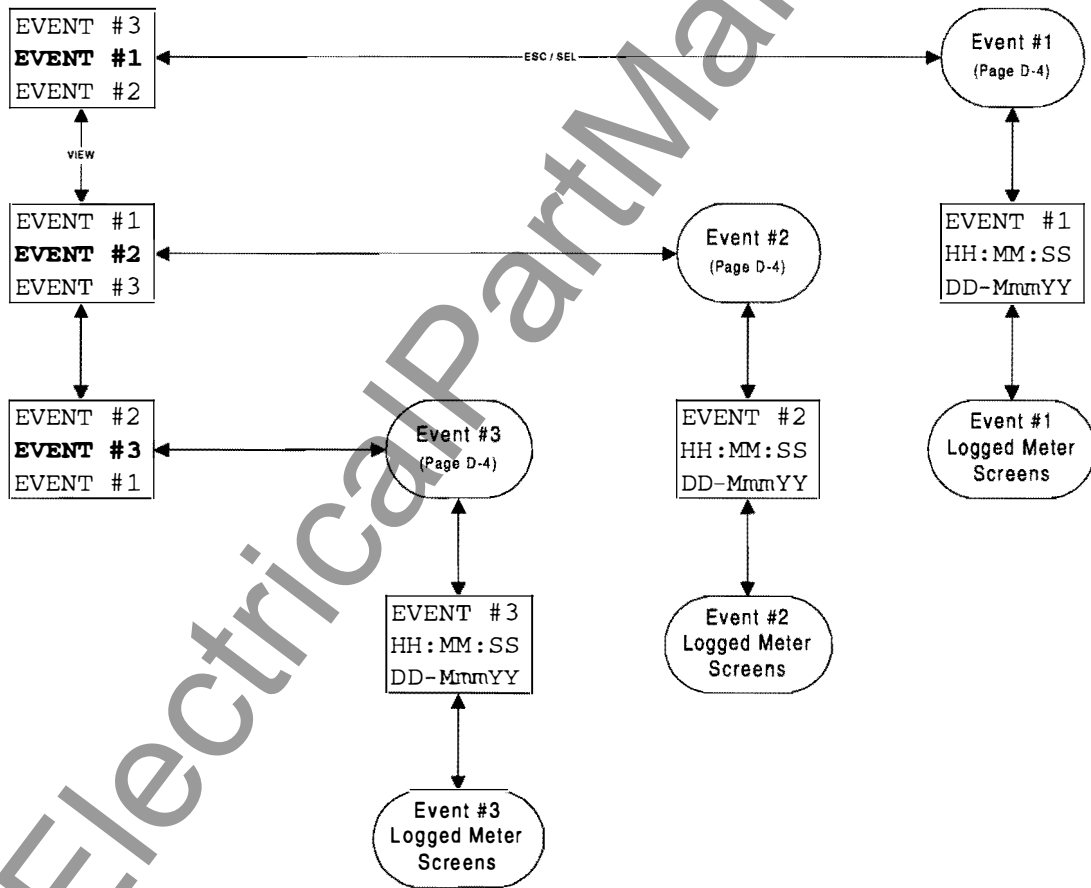

Possible Events and Logged Meter Menu screen(s) are listed on the following page. Default time is Jan with other values set to 0.

Appendix D Page D-4

(Continued from D-3)

Note: "Meter screens" refer to those on D-2

Possible Events

Data logged and shown for each event.

Alarm screens will be real-time messages

LONG DELAY TRIP

1st & 2nd Meter screens Note 1

OVER TEMP TRIP

No data displayed

NEUTRAL AMPERE ALARM

1st & 2nd Meter screens

SHORT DELAY TRIP

1st & 2nd Meter screens

RATING PLUG TRIP

No data displayed

HIGH LOAD ALARM

3rd Meter screen

INST TRIP

1st & 2nd Meter screens Note 2

MAKING CURRENT TRIP

No data displayed

LDCU ALARM

1st & 2nd Meter screens

NEUTRAL TRIP

1st & 2nd Meter screens Note 3

PHASE LOSS TRIP

3rd Meter screen

OP COUNT ALARM

Operate Counter Meter screen

GROUND FAULT TRIP

1st & 2nd Meter screens Note 4

HIGH INST TRIP

No data displayed

kW DEMAND ALARM

kW Meter screen

OPEN BY COMM

No data displayed

Alarm screen will be real-time messages

kVA DEMAND ALARM

kVA Meter screen

ACC BUS TRIP

No data displayed

LOW PF ALARM

PF Meter Screen

THD ALARM

THD Harmonics Screen

AMPERES OUT OF BALANCE

1st Meter screens

GROUND ALARM

1st & 2nd Meter screens Note 4

3. NEUTRAL TRIP is a Long Delay Trip on Neutral or 4th pole

1. LONG DELAY TRIP term is used by LSI, IEEE and IEC curve type indicating an overload trip.

2. INST TRIP values displayed could be less than actual fault levels due to fast response of this element.

4. If IEC -EF style, "EARTH" will replace "GROUND"

(Continued from D-1)

View Settings  
◆Menu

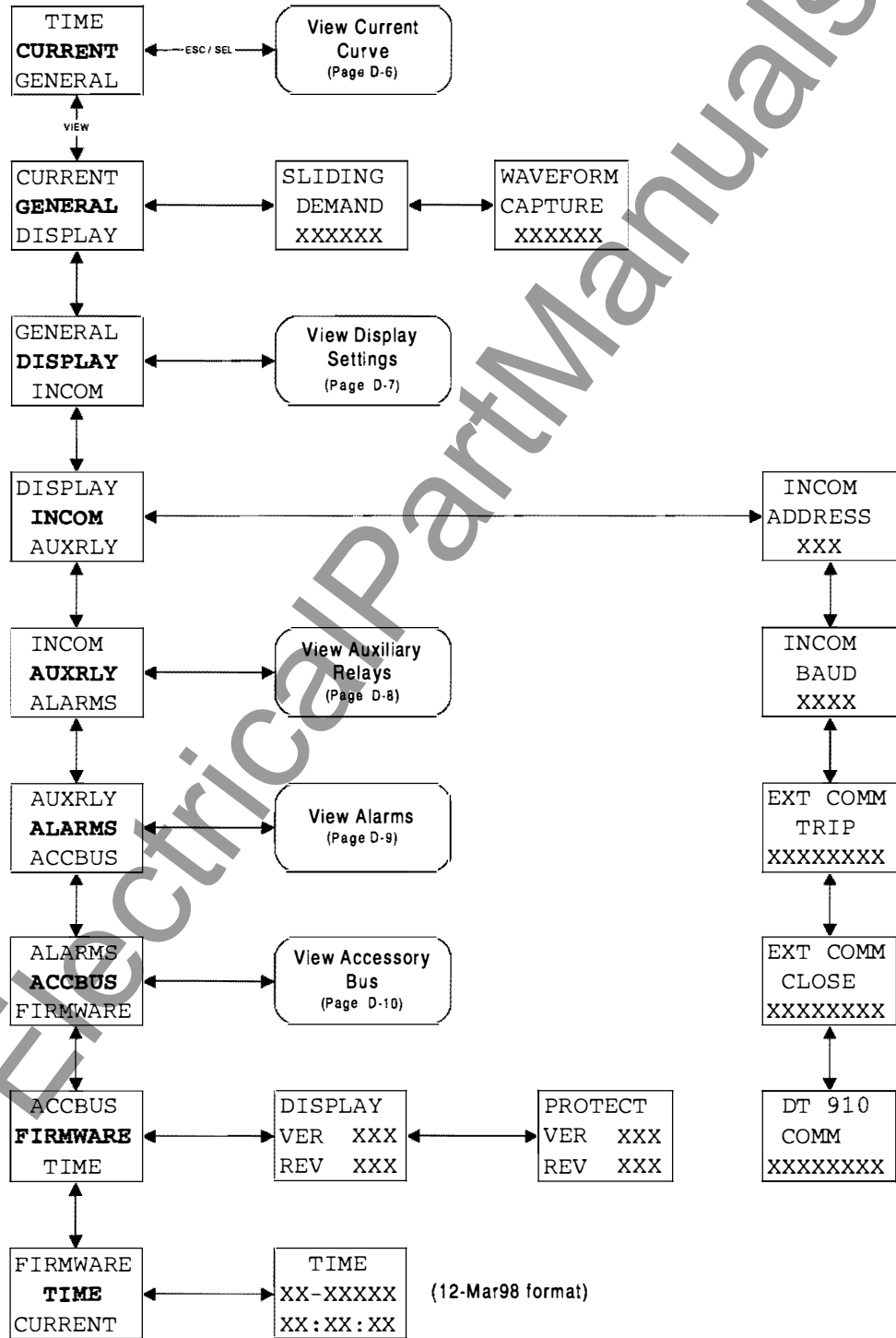

Appendix D Page D-6

(Continued from D-5)

Selected curve and trip style determines the menus shown. The user can only view the curve set in Program Settings Menu.

View Current Settings

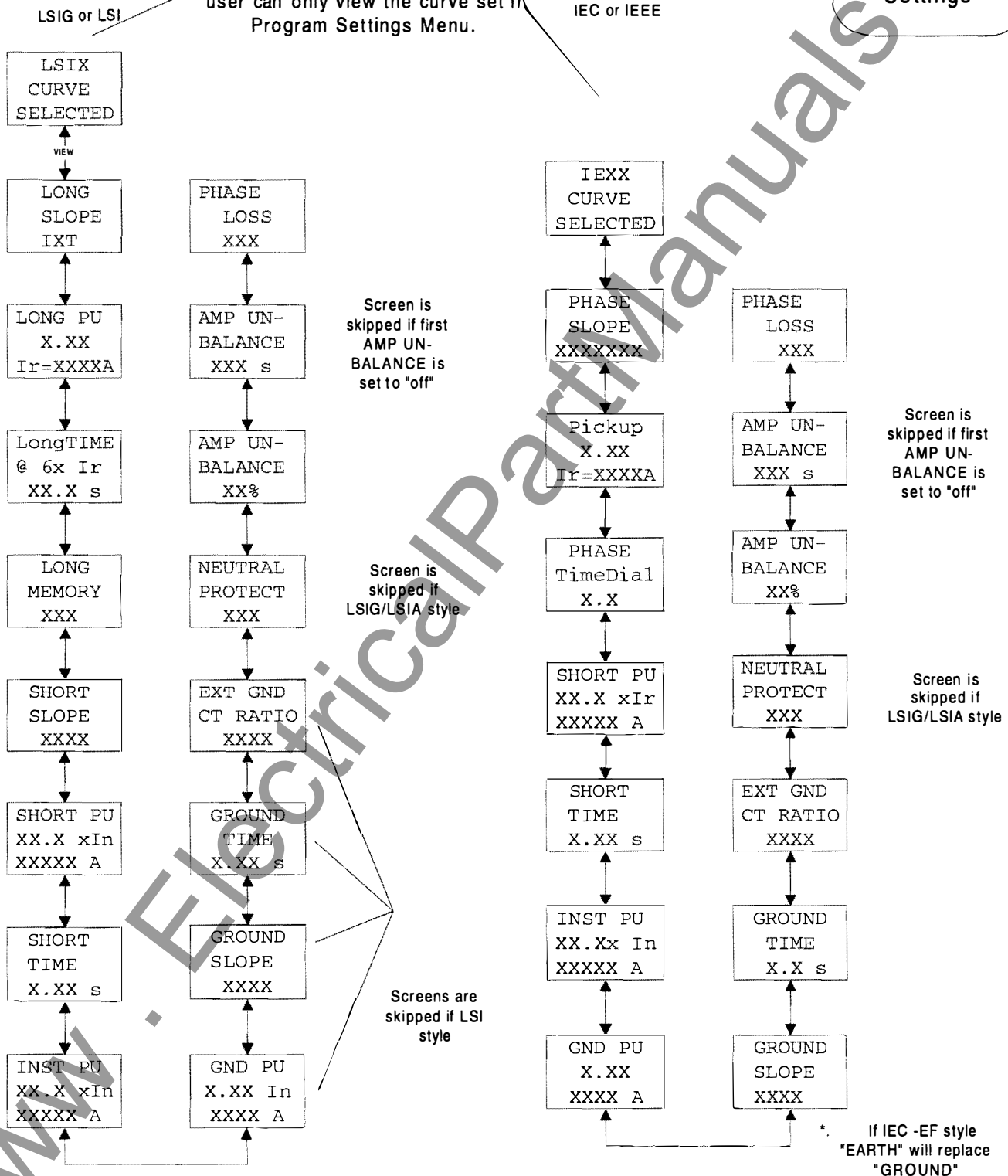

(Continued from D-5)

View Display Settings

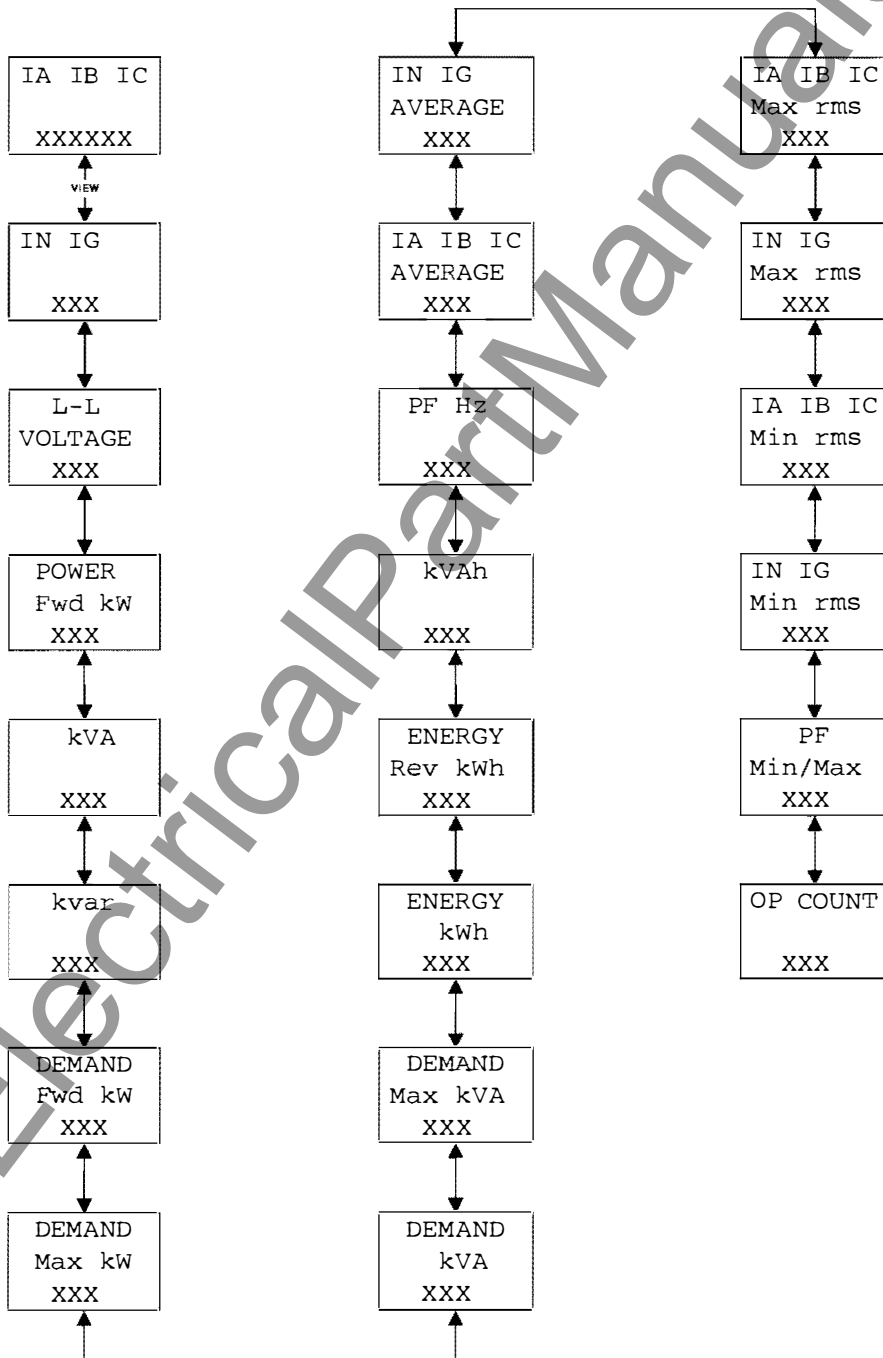

Appendix D Page D-8  
(Continued from D-5)

View Auxiliary Relay Menu

X = "\*" (asterisk) is placed beside the relay letter when at least one of its RELAY functions is ENABLED.

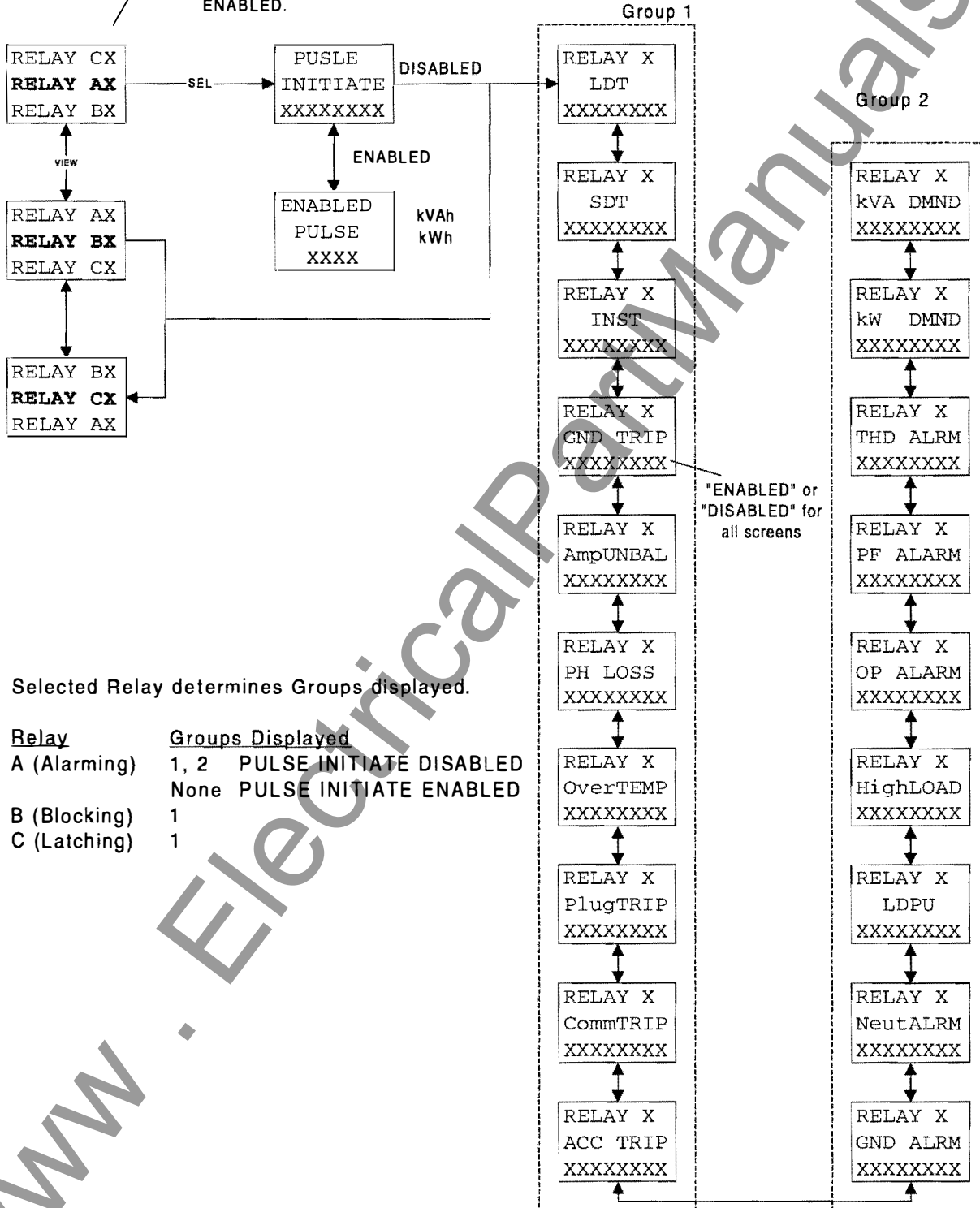

Selected Relay determines Groups displayed.

Relay	Groups Displayed
A (Alarming)	1, 2 PULSE INITIATE DISABLED
B (Blocking)	None PULSE INITIATE ENABLED
C (Latching)	1

(Continued from D-5)

View Alarms

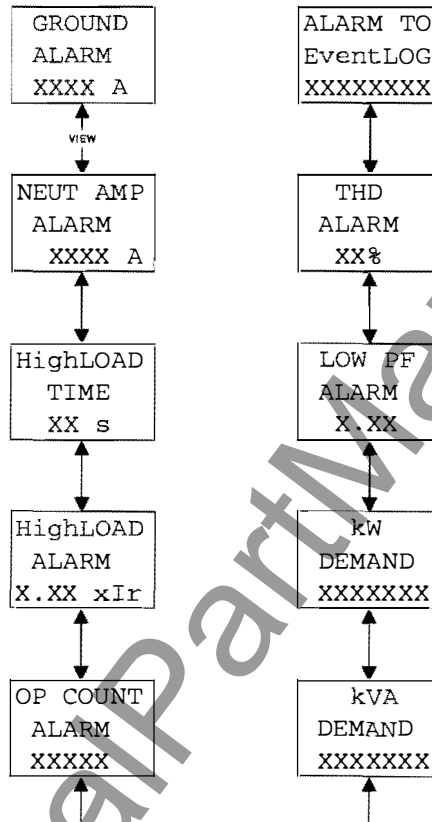

Non-Selectable Alarm

LDPU ALARM

WATCHDOG ALARM

SETTINGS ERROR ALARM

EEROM ALARM

The message LDPU indicates an overload condition. This term is used for a Pickup alarm on LSI, IEEE or IEC protection curves.

\*. If IEC -EF style "EARTH" will replace "GROUND"

(Continued from D-5)

View Accessory Bus Settings

"XXXXXXXX = NO SETTINGS If no relay functions are enabled  
XXXXXXXX" DIGITAL OUTPUT If any relay functions are enabled

Save (Page D-19)

Each of the 4 addresses is a separate Save group

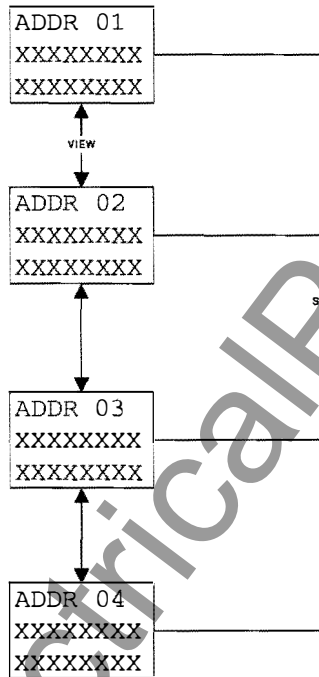

RLY	FUNC
1	□□□□
2	XXXX

RLY	FUNC
2	□□□□
3	XXXX

RLY	FUNC
3	□□□□
4	XXXX

RLY	FUNC
4	□□□□
1	XXXX

- OFF
- AUX
- BELL
- DEAD
- ALARM
- WATCH

(Continued from D-1)

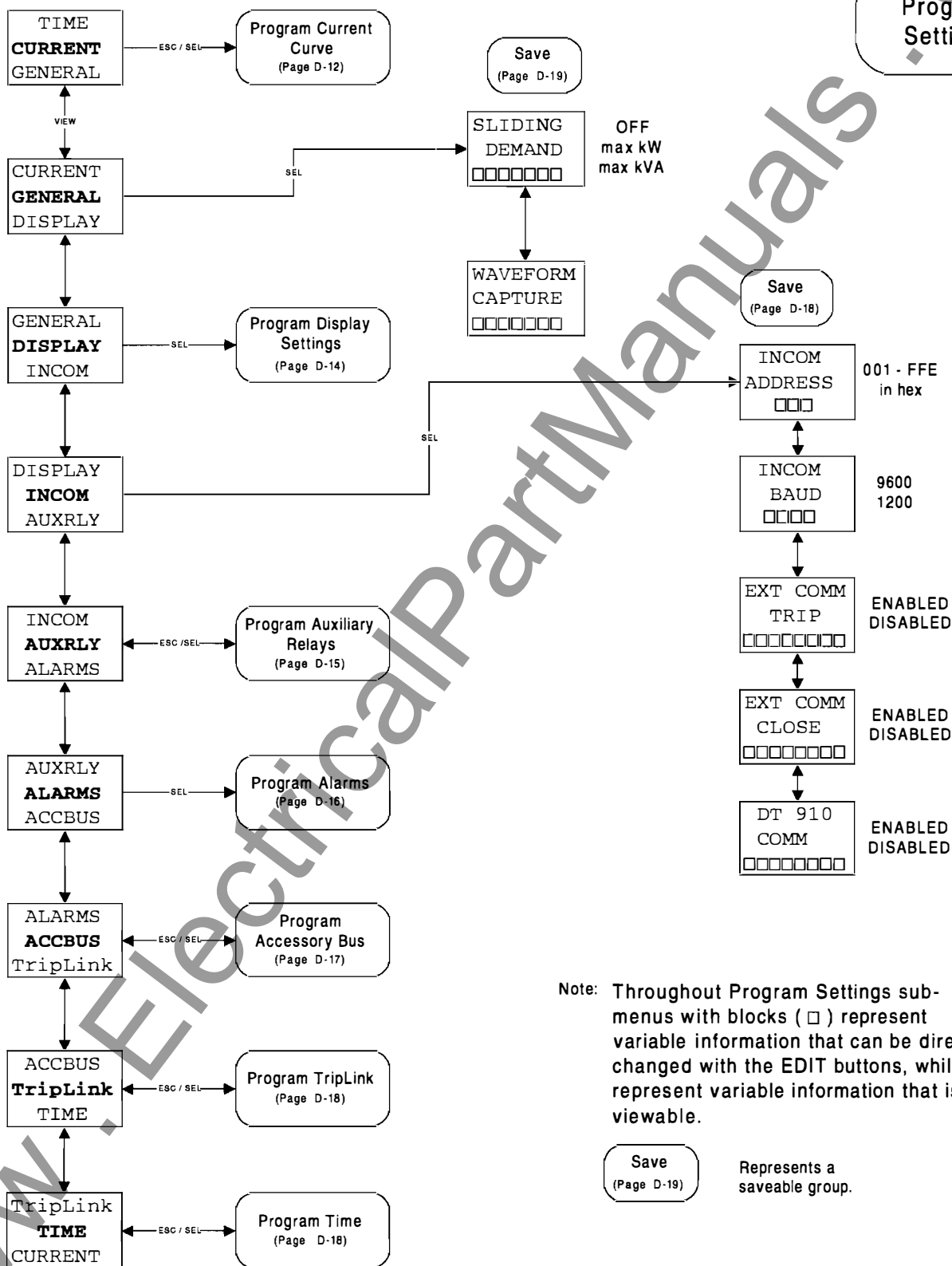

Appendix D Page D-12

(Continued from D-11)

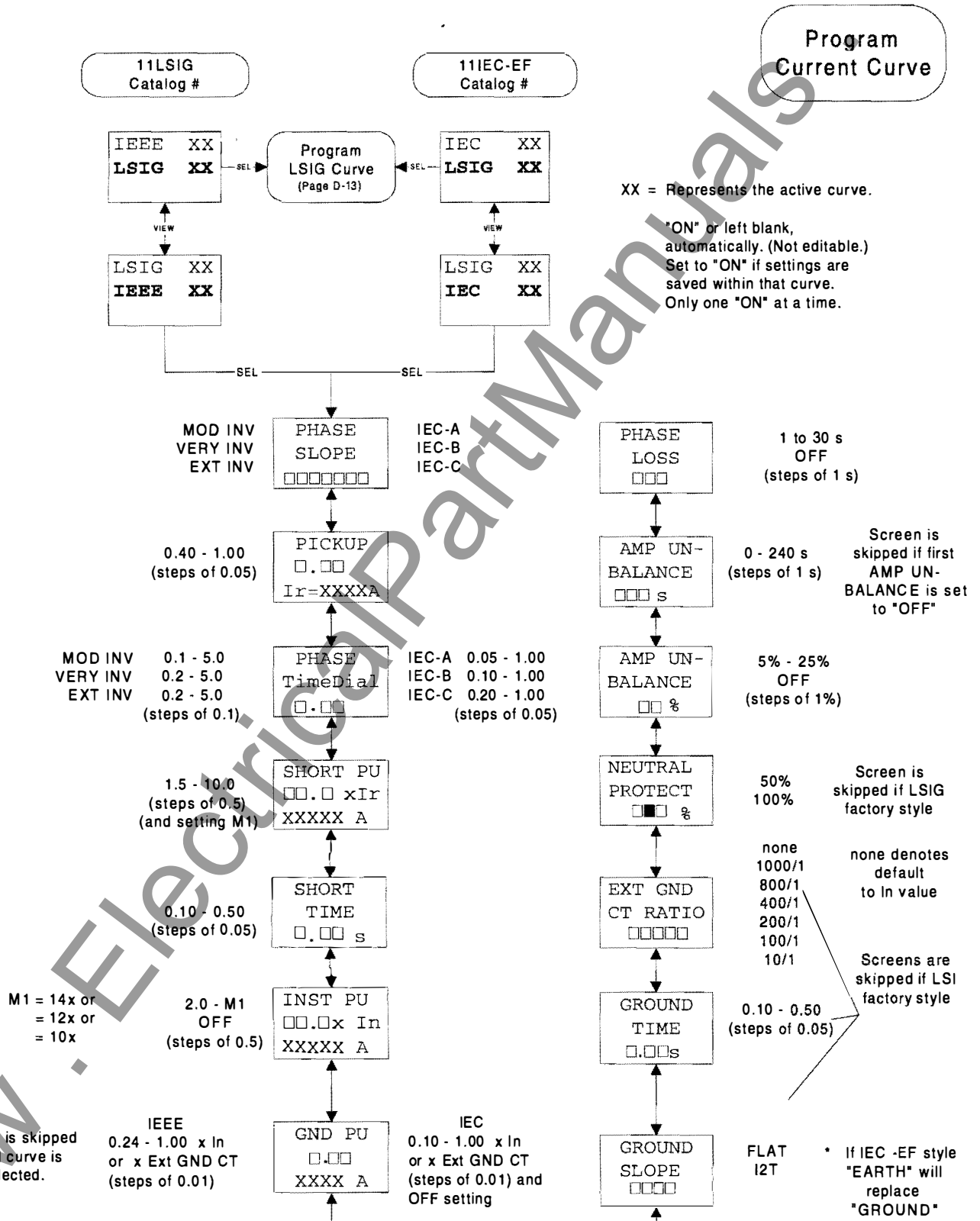

(Continued from D-12)

Save  
(Page D-19)

Program LSI-G  
Curve

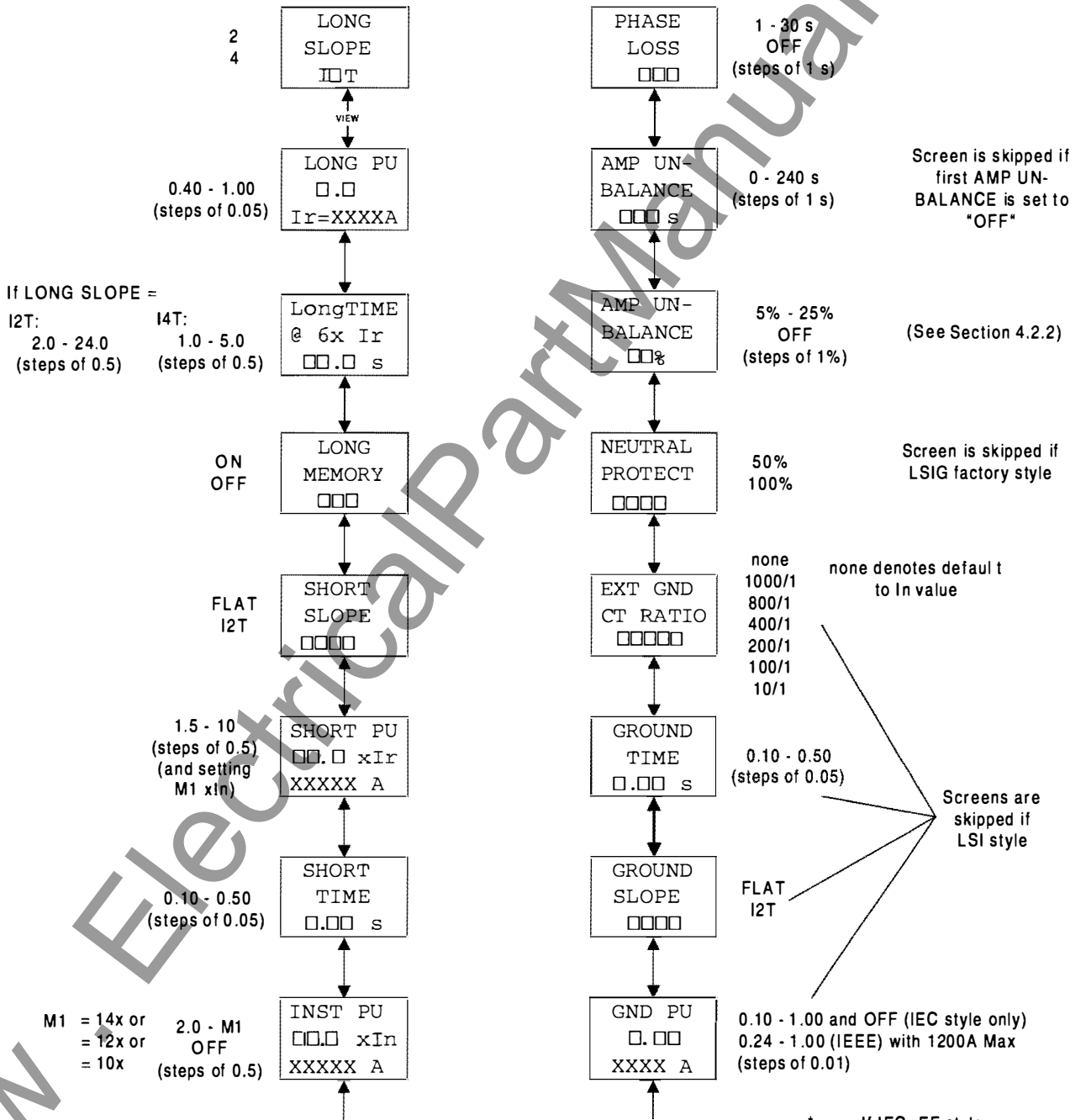

Appendix D Page D-14

(Continued from D-11)

Program  
Display  
Settings

Save  
(Page D-19)

AUTO  
MANUAL

ON  
OFF

All display screens except  
the first use "ON" or "OFF".

IA IB IC  
□□□□□

VIEW

IN IG  
□□□

L-L  
VOLTAGE  
□□□

POWER  
Fwd kW  
□□□

kVA  
□□□

kvar  
□□□

DEMAND  
Fwd kW  
□□□

DEMAND  
Max kW  
□□□

IN IG  
AVERAGE  
□□□

IA IB IC  
AVERAGE  
□□□

PF Hz  
□□□

kVAh  
□□□

ENERGY  
Rev kWh  
□□□

ENERGY  
kWh  
□□□

DEMAND  
Max kVA  
□□□

DEMAND  
kVA  
□□□

IA IB IC  
Max rms  
□□□

IN IG  
Max rms  
□□□

IA IB IC  
Min rms  
□□□

IN IG  
Min rms  
□□□

PF  
Min/Max  
□□□

OP COUNT  
□□□

(Continued from D-11)

X = "\*" (asterisk) is placed beside the relay letter when at least one of its TRIP or ALARM functions is ENABLED.

Save  
(Page D-19)

Program Aux  
Relays Menu

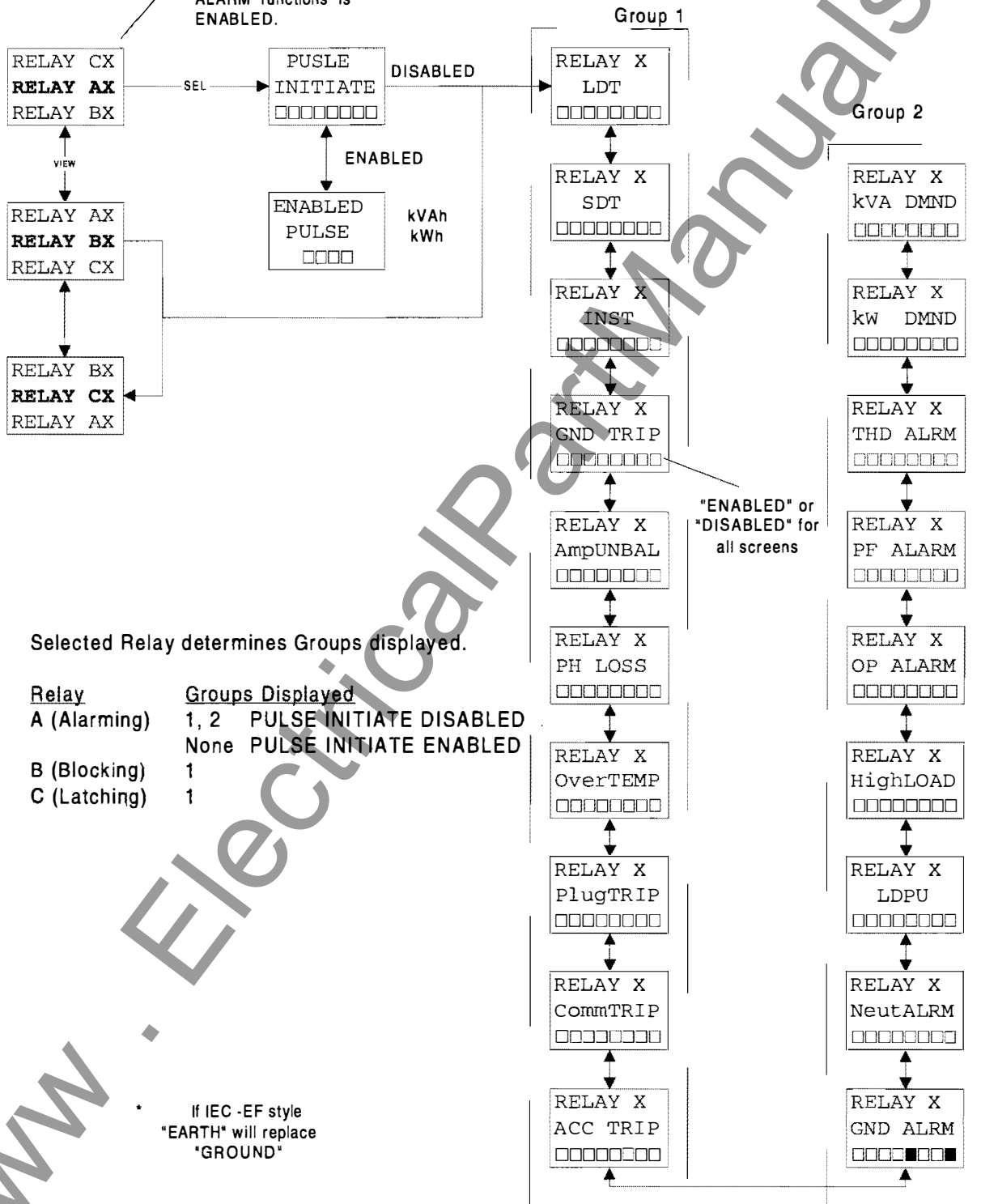

Selected Relay determines Groups displayed.

Relay	Groups Displayed
A (Alarming)	1, 2 PULSE INITIATE DISABLED
	None PULSE INITIATE ENABLED
B (Blocking)	1
C (Latching)	1

\* If IEC -EF style  
"EARTH" will replace  
"GROUND"

Appendix D Page D-16

(Continued from D-11)

Program Alarms

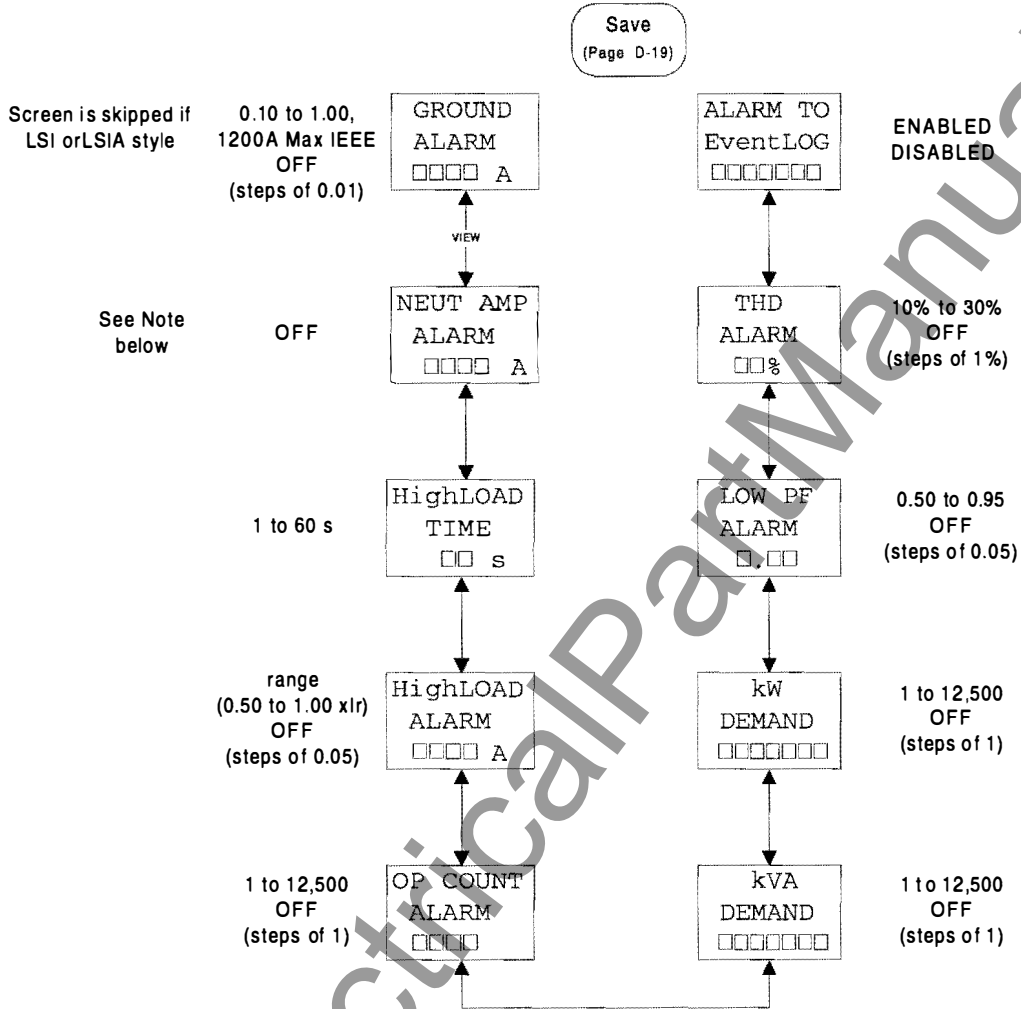

Notes: Front Panel Display of NEUTral AMPere ALARM will be in amperes. Equation used is:

$$\text{Amperes} = I_n (\text{amperes}) \times \text{Neutral Alarm Pickup Setting} \quad (0.10 \text{ to } 1.0 \times I_n \text{ is range})$$

The Neutral Alarm (if not set to OFF) will also alarm if Neutral (Long Pickup value) is exceeded.  
 The Neutral alarm function is not possible on breakers used in a Source Ground or Zero Sequence Ground Fault application.

\* If IEC -EF style  
 "EARTH" will replace  
 "GROUND"

(Continued from D-11)

Program Accessory Bus

"XXXXXXXX = NO SETTINGS If no relay functions are enabled  
XXXXXXXX " DIGITAL OUTPUT If any relay functions are enabled

Save (Page D-19)

Each of the 4 addresses is a separate Save group

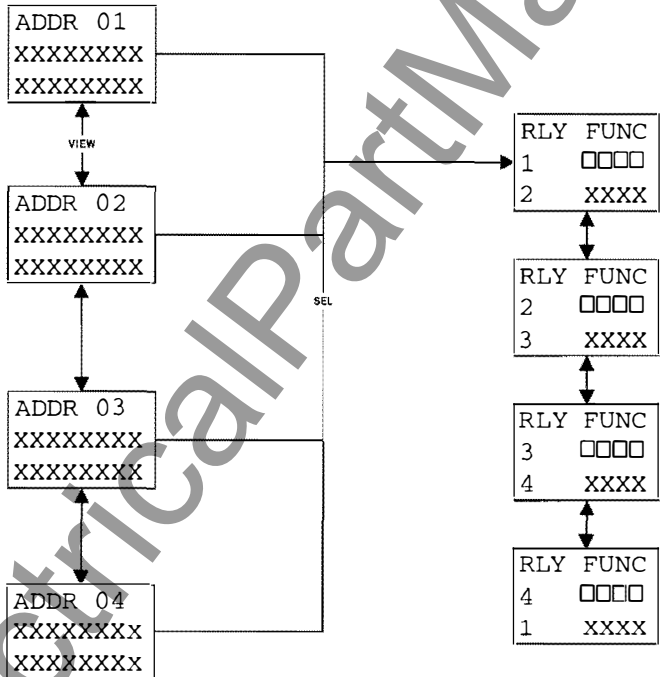

OFF  
AUX  
BELL  
DEAD  
ALARM  
WATCH

www.ElectricalPartManuals.com

Appendix D Page D-18

(Continued from D-11)

Receiving breaker is open,  $V_{L-L}=0$ , IA, IB, and IC phase currents =0, and both breakers involved have same rating plug/frame and style?

Program TripLink

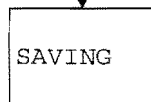
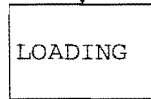
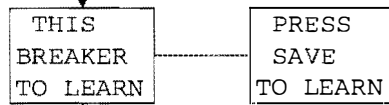
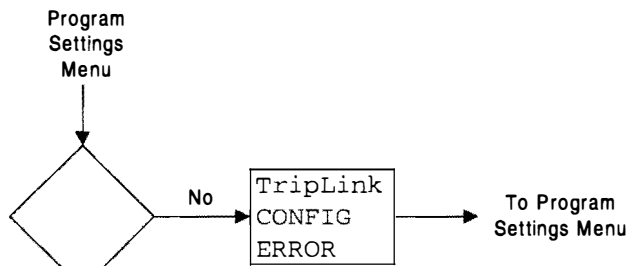

transfer successful?

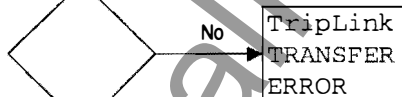

To Program Settings Menu



Program Time

Save (Page D-19)

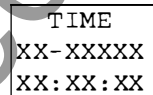

12-Mar98 format

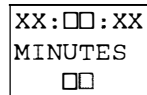

As each value is edited, the top line will reflect the change.

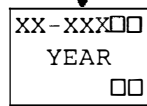
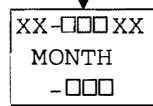
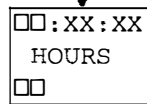
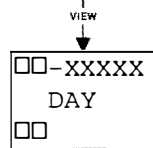

(Continued from D-11)

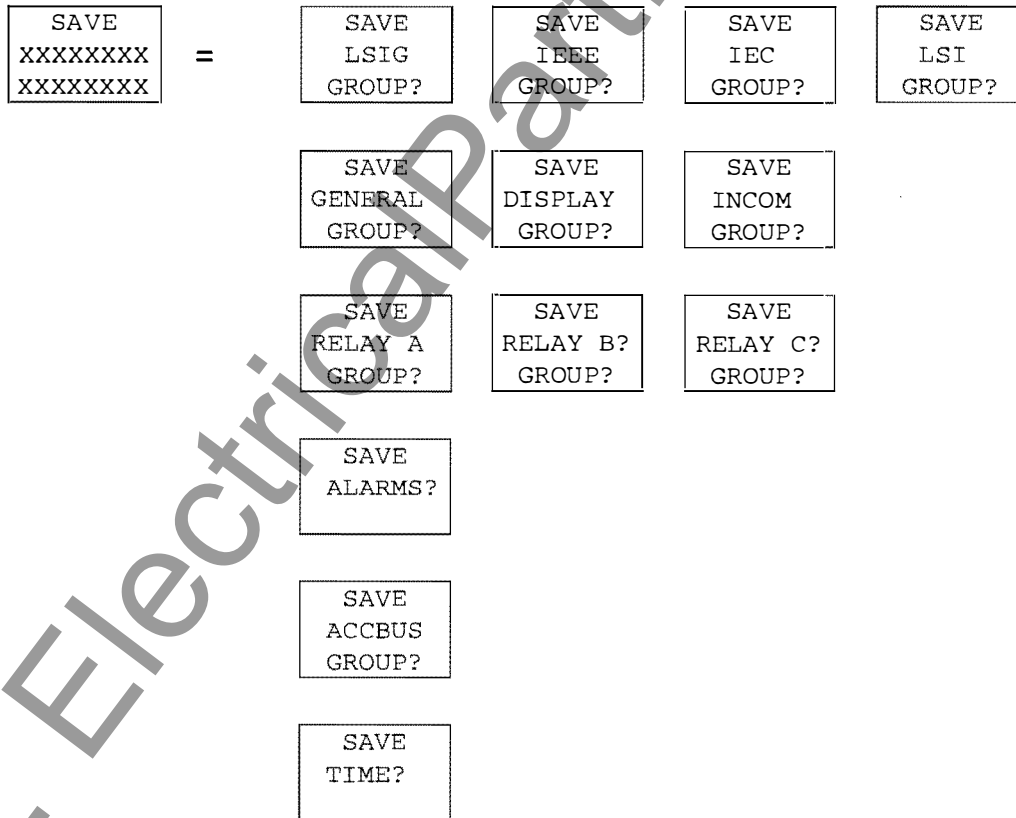
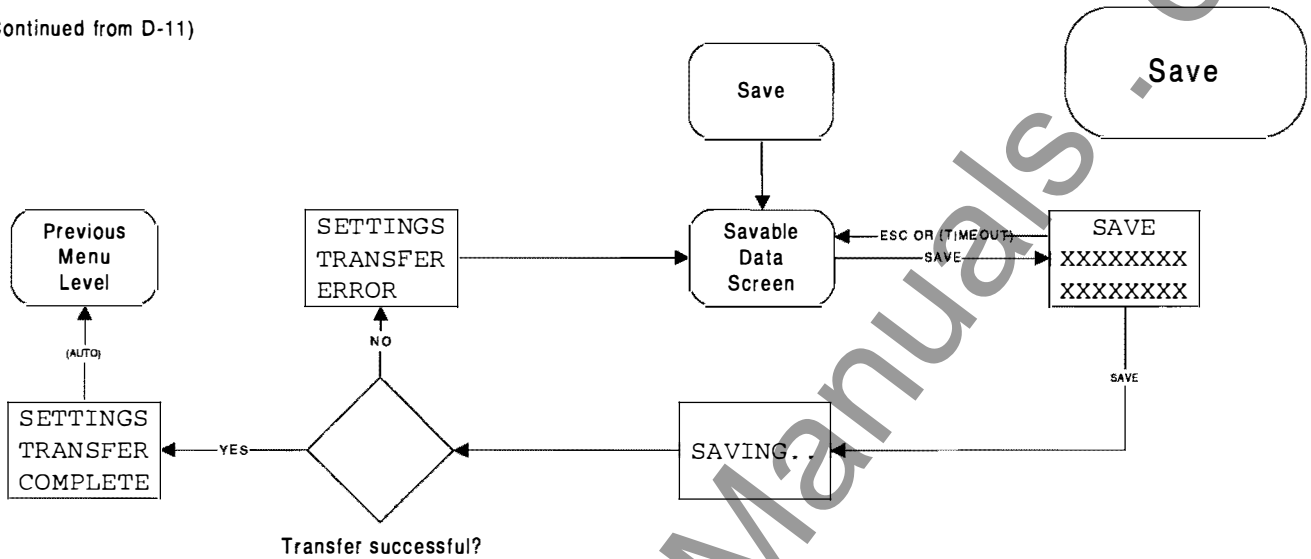

Appendix D Page D-20

(Continued from D- 1)

NOTE: If LSI curve is selected GND TEST will not be available

Test Menu

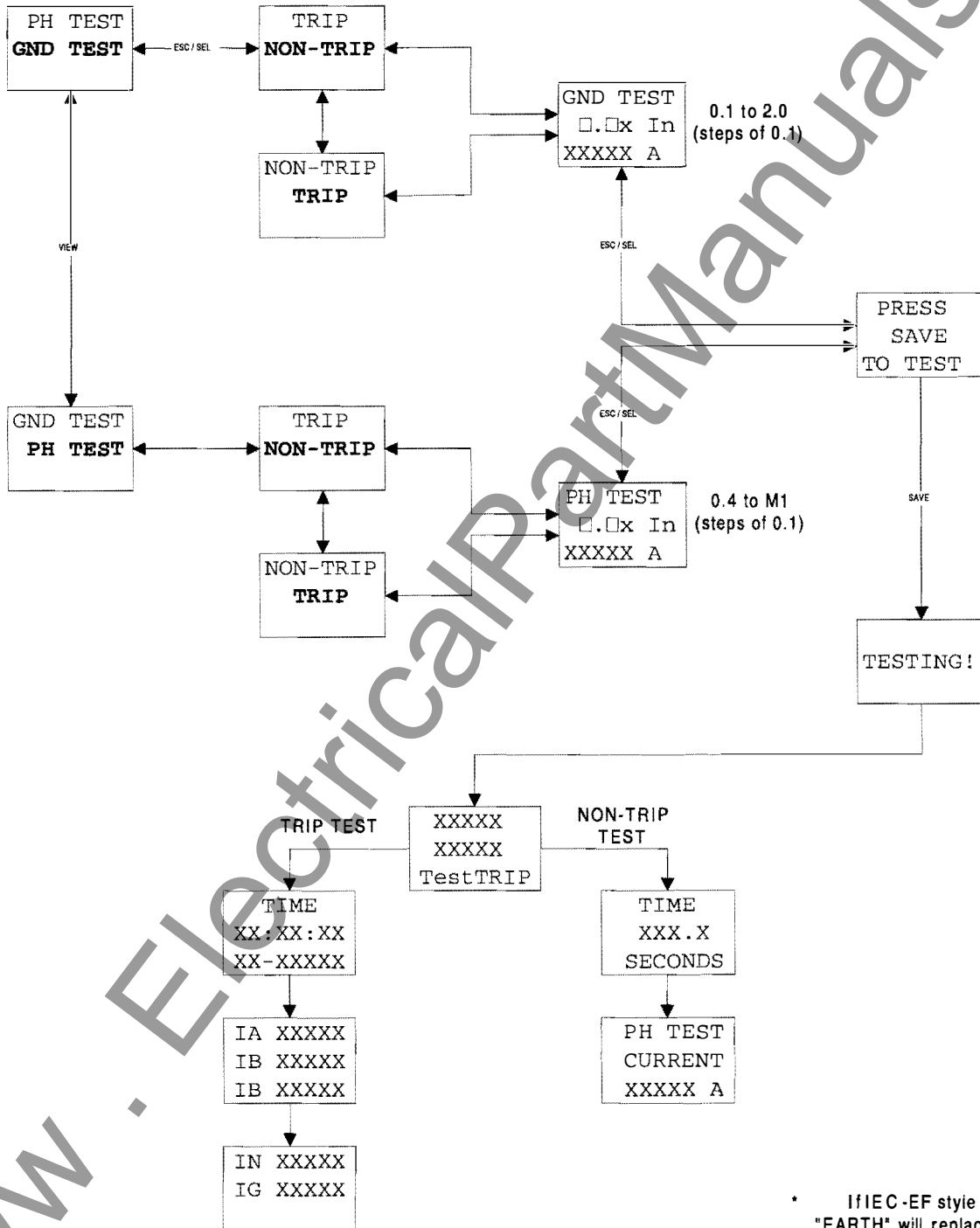

\* If IEC-EF style "EARTH" will replace "GROUND"

(Continued from D-1)

Harmonics  
Menu

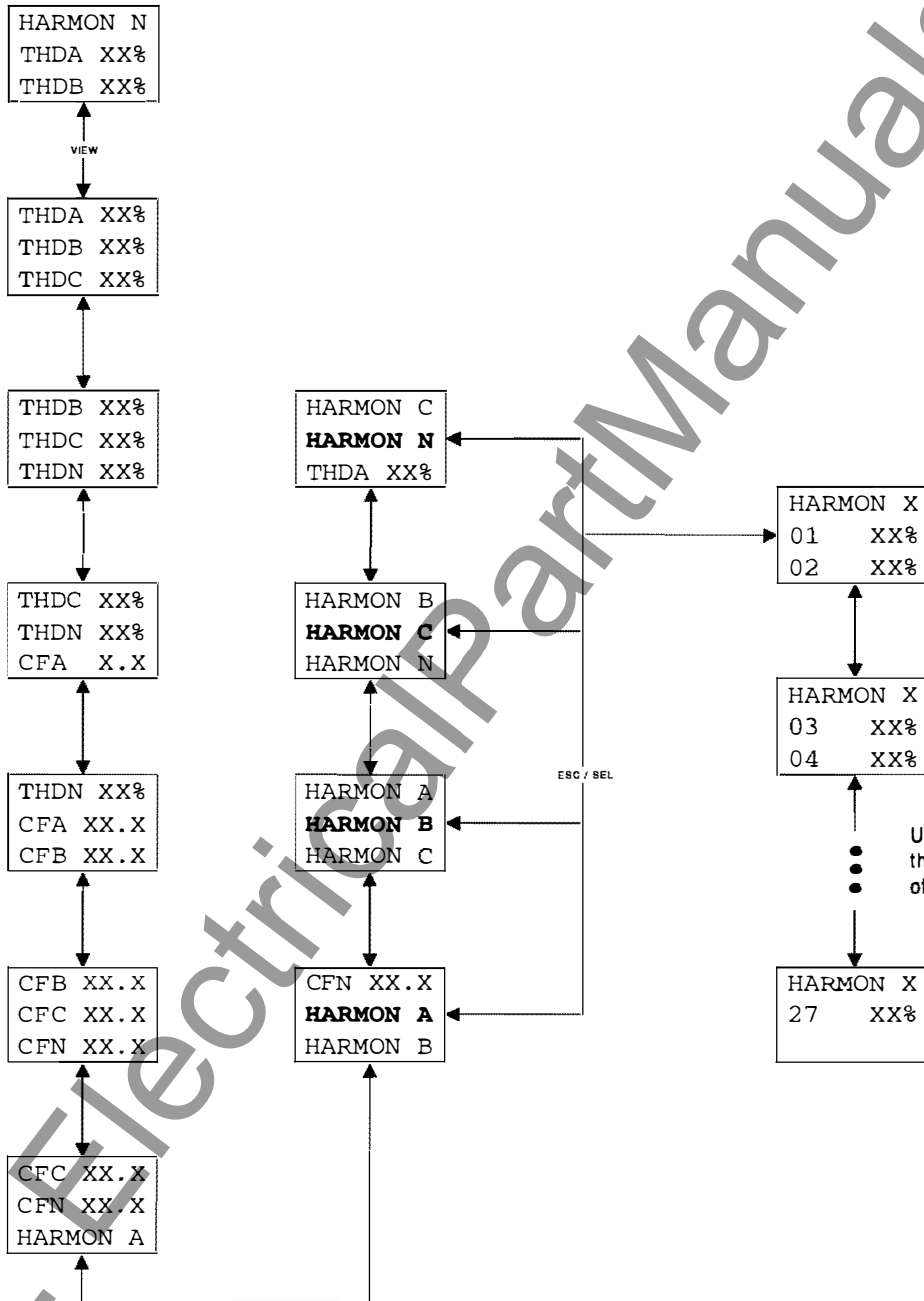

Using the View keys to scroll,  
the 1st through 27th harmonic  
of each line can be viewed.

## Multiple Alarm Screens

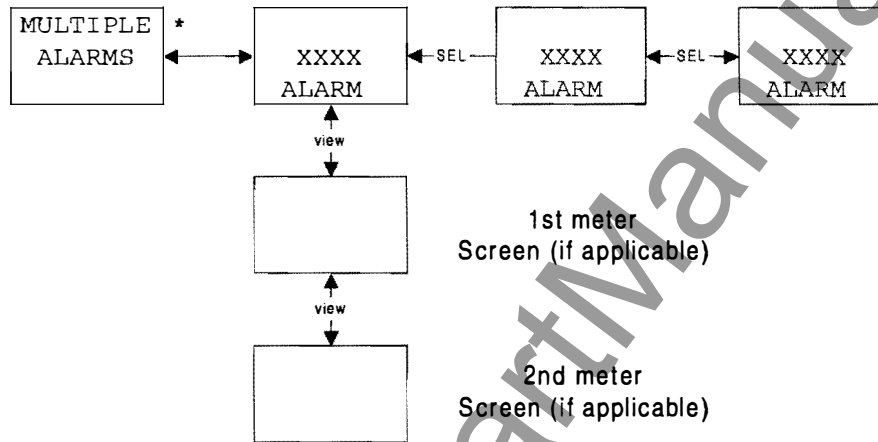

**\* Note:**

If more than one alarm condition exists in the system, the "Multiple Alarm" screen will be displayed and alternate with one of the alarm causes. Pressing the select pushbutton will display the next alarm condition. Pressing the ESCape will exit out and return to normal menu screen. However, the Alarm LED stays on as a reminder.

Factory Settings

LSIG ON

<u>LSIG Current Curve</u>		<u>IEEE Curve</u>		<u>IEC Curve</u>	
LONG SLOPE	I2T	PHASE SLOPE	MOD INV	PHASE SLOPE	IEC - A
LONG PU	1.00	Pickup	1.00	Pickup	1.00
LONG TIME	4.0 s	PHASE TimeDial	2.0	PHASE TimeDial	0.20
LONG MEMORY	ON	SHORT PU	3.0	SHORT PU	3.0
SHORT SLOPE	FLAT	SHORT TIME	0.30 s	SHORT TIME	0.30 s
SHORT PU	3.0	INST PU	4.0	INST PU	4.0
SHORT TIME	0.30 s	GROUND PU**	0.40 <sup>2</sup>	EARTH PU**	0.40
INST PU	4.0	GROUND SLOPE****	FLAT	EARTH SLOPE****	FLAT
GROUND PU**	0.40 <sup>2</sup>	GROUND TIME****	0.30 s	EARTH TIME****	0.30 s
GROUND SLOPE****	FLAT	EXT GND CT RATIO**	none	EXT EARTH CT RATIO**	none
GROUND TIME****	0.30 s	NEUTRAL PROTECT*	100%	NEUTRAL PROTECT*	100%
EXT GND CT RATIO**	none	AMP UNBALANCE	OFF	AMP UNBALANCE	OFF
NEUTRAL PROTECT*	100%	AMP UNBALANCE (time)	10 s	AMP UNBALANCE (time)	10 s
AMP UNBALANCE	OFF	PHASE LOSS	OFF	PHASE LOSS	OFF
AMP UNBALANCE (time)	10 s				
PHASE LOSS	OFF				

- \* Applicable on 11LSI or 11IEC factory styles only
- \*\* Applicable on 11LSIG, 11LSIA and 11IEC-EF
- \*\*\* Only available on LSIG, LSI, LSIA Current Curve. On IEEE curve and IEC curve, LONG MEMORY and SHORT I2T SLOPE settings are not available.
- \*\*\*\* Applicable on 11LSIG, 11IEC-EF

DISPLAY (6 active)

IA IB IC	AUTO
IN IG	ON
L-L VOLTAGE	ON
FwdPower	ON
PF HZ	ON
ENERGY FWD & REV (all others)	ON
	OFF

INCOM

INCOM ADDRESS	100 hex
INCOM BAUD RATE	9600
EXT COMM TRIP	ENABLED
EXT COMM CLOSE	ENABLED
DT 910 COMM	DISABLED

AuxReLaYs	All relays DISABLED
ALARMS	All alarms OFF <sup>1</sup>
ACC BUS Switch	Address 1 Relay 1 is Aux.-Aux All other addresses and relays OFF

TEST

PH TEST	0.4x In
GND TEST	0.1x In

1. Except LSIA will have Ground Alarm on @ .40x
2. Plug ratings 3200, 4000, 5000, 6300 A are set to .24

## Appendix E Display Abbreviations

Glossary  
of Terms  
A-L

	<u>Abbreviation</u>	<u>Definition</u>	<u>Notes</u>
<b>A</b>	A, AMP	amperes	
	ACC	accessory	
	ACCBUS	accessory bus	
	ADDR	address	
	ALRM	alarm	
	AmpUNBAL	amperes out of balance	
	AUX	auxiliary	
	AuxRLY	auxiliary relay	
<b>B</b>	AVG	average	
<b>C</b>	CF	crest factor	
	COMM	communications	
	CommTRIP	communications trip	
<b>D</b>	CT	current transformer	
	DD	day	
	DMND	demand	
<b>E</b>	DT	Digitrip	
	Erth	earth	
	ESC	ESCAPE pushbutton on Digitrip	
<b>F</b>	EVNT	event	
	EXT	external	
	FREQ	frequency	
<b>G</b>	FUNC	function	
	FwdPower	forward power	
	GND	ground	
<b>H</b>	GroundPU	ground pickup	
	HARMON	harmonic	
<b>I</b>	HH	hours	
	HZ	hertz	
	IA	phase A current	
<b>J</b>	IB	phase B current	
	IC	phase C current	
	IEC	International Electrotechnical Commission	
	IEEE	Institute of Electrical and Electronics Engineers	
	IG	ground current	
	IN	neutral current	
	INST	instantaneous	
	INV	inverse	
	In	max continuous current rating	
	Ir	continuous current rating	
<b>K</b>	kVA	kilovolt ampere	
	kVAh	kilovolt ampere hour	
	kvar	kilovolt ampere reactive	
	kW	kilowatt	
	kWh	kilowatt hour	
<b>L</b>	L-L	line-to-line	
	LONG PU	long delay pickup	
	LDPU	long delay pickup	
	LDT	long delay trip	
	LSI	Long, Short, Instantaneous Trip	
	LSIA	Long, Short, Instantaneous Trip, Ground Alarm Only	
	LSIG	Long, Short, Instantaneous, Ground Trip	

Glossary  
of Terms  
M-Z

	<u>Abbreviation</u>	<u>Definition</u>	<u>Notes</u>
<b>M</b>	Max	maximum	
	Min	minimum	
	MIN	minute	
	MM	minutes	
	Mmm	month	
<b>N</b>	NEUT	neutral	
	NeutALRM	neutral alarm	
<b>O</b>	OP	operation	
	OverTEMP	over temperature	
<b>P</b>	PF	power factor	
	PGM	program	
	PH	phase	
	PICKUP	pickup	Also known as Long PU and LDPU
	PlugTRIP	rating plug trip	
	PROTECT PU	protection pickup	
<b>Q</b>			
<b>R</b>	REV	revision	
	Rev	reverse	
	RevPower	reverse power	
	RLY	relay	
	rms	root-mean-squared	
<b>S</b>	s	seconds	
	SDT	short delay trip	
	SEL	SELEct pushbutton on Digitrip	
	SET	settings	
	SETTINGS	setting	
	SS	seconds	
<b>T</b>	TEMP	temperature	
	THD	total harmonic distortion	
<b>U</b>	UNBAL	unbalance	
<b>V</b>	V	volts	
	VAB	line voltage from phase A to phase B	
	VBC	line voltage from phase B to phase C	
	VCA	line voltage from phase C to phase A	
	VER	version	
<b>W</b>			
<b>X</b>			
<b>Y</b>	YY	year	
<b>Z</b>			

## Appendix F Digitrip Settings and Descriptions

## Digitrip 1150 Settings

Setting	Description
Protection Firmware version	The protection firmware version number, in hexadecimal.
Display Firmware version	The display firmware version number, in hexadecimal.
Curve Type	The curve type: LSI – Long, Short, Instantaneous LSIG – Long, Short, Instantaneous, Ground LSIA – Long, Short, Instantaneous, Alarm on Ground only IEEE – (IEEE Mod. Inv., Very Inv., Extremely Inv.) Short, Instantaneous IEC – (IEC-A, -B, -C) Short, Instantaneous
Rating (In)	Breaker MAX Full Load Current Continuous Rating (In) in Amperes (PLUG RATING).
Frequency	Measured system frequency of voltage.
Ground Current Sensing	Residual or Source ground or Zero Sequence.
Long Delay Pickup = Ir	Defines a current level where load current above this setting will cause an eventual trip.
Rating (Ir)	The continuous current setting of the breaker.
Long Delay Slope	Shape of the inverse-time-over-current (Long TIME) curve: I2T I4T
Long Delay Time	The time delay setting in seconds before tripping @ 6xIr current level.
Short Delay Pickup (a multiple of Ir)	Defines a current setting usually set much higher than continuous current that will initiate timing of this function.  When the current reaches and sustains the level of the pickup setting for the period defined by the Short Time setting, the breaker trips.
Short Delay Slope	Shape of the Short Time Curve. FLAT (fixed time) I2T (applicable with I2T Long Delay Slope only)
Short Delay Time	The delay time before tripping after short delay is picked up.
Instantaneous Pickup (a multiple of In)	Current above this setting will trip the breaker immediately.
Ground (Earth) Fault Pickup (a multiple of In)	Ground current above this setting will initiate a Ground trip or Ground alarm.
Ground (Earth) Slope	Shape of the Ground Curve: FLAT (fixed time) I2T
Ground (Earth) Time Pickup	The delay time before tripping on Ground.
Rating (Ir)	The continuous current setting of the breaker.
TimeDial	The TimeDial setting controls the time scale that determines the tripping of the inverse time characteristic for an IEEE or IEC curve.
Amperes Out of Balance Trip % Unbalance	Percent difference setting between the Max and Min phase currents which, when exceeded, will trip the breaker.
Amperes Out of Balance Trip Time	The required duration of the Amperes Out of Balance Trip condition before the breaker trips.
Phase Loss Trip Time	The Phase Loss Time is the duration of a phase loss condition before the breaker trips. This function will trip when a 75% difference between Max phase and the Min phase currents exists.
External Ground Scale Factor	User selectable Ground CT Ratio (when applicable).
Neutral Ratio	User selectable. 50% or 100%. Select 50% for protecting ½ size neutral conductors. (Applicable for non-ground fault units only.)
4 <sup>th</sup> Pole Protection	Neutral or 4 <sup>th</sup> pole protection. (Applicable for non-ground fault style units.)

## Digitrip 1150 Settings (continued)

Setting	Description
Long Memory (Thermal Memory)	Indicates whether over-current memory function is on or off. (Applicable on LSI, LSIG and LSIA curves only.)
Sliding Window Assignment	Determines if the maximum kW demand or the maximum kVA demand is calculated on a fixed or sliding 15-minute window.
Auto Waveform Capture Interval	The time between auto waveform captures.
High INST Trip	The breaker tripped at a high fault current via separate High INST Module. See Appendix C.
High Load Alarm	When the current reaches the setting, a High Load Alarm occurs.
High Load Time	The breaker waits the duration of the High Load Time before entering into an alarm condition.
Alarm to Event Log	When enabled, alarm events are stored into the Event Log.
Ground Pickup Alarm	When ground current exceeds this setting, a Ground Pickup Alarm occurs (when applicable).
Neutral Pickup Alarm	When neutral current exceeds this setting, a Neutral Pickup Alarm occurs.
Breaker Operations Count Alarm	When breaker operations count exceeds this setting, a Breaker Operations Count Alarm occurs.
Low Power Factor Alarm	When the power factor falls below this setting, a Low Power Factor Alarm occurs.
THD Alarm	When the percent THD exceeds this setting, a THD Alarm occurs.
kW Demand Alarm	When the kW demand reaches this setting, a kW Demand Alarm occurs.
kVA Demand Alarm	When the kVA demand reaches this setting, a kVA Demand Alarm occurs.
Activate Alarm Relay A on Trip	The trip conditions upon which Alarm Relay A is activated: Long Delay Short Delay Instantaneous Ground Fault Ampere Unbalance Phase Loss Over Temperature Rating Plug External Communications Accessory Bus
Pulse Initiate Relay A	The pulse initiator, a means of measuring kWh of kVAh energy, is on or off. If on, no other functions can be assigned to Relay A.
Activate Alarm Relay A on Alarm	The alarm conditions upon which Alarm Relay A is activated: Ground Neutral Amp Long Delay Pickup High Load Operations Count Low Power Factor THD kW Demand kVA Demand

## Digitrip 1150 Settings (continued)

Setting	Description
Activate Block Close Relay B on Trip	The trip conditions upon which Block Close Relay B is activated: Long Delay Short Delay Instantaneous Ground Fault Ampere Unbalance Phase Loss Over Temperature Rating Plug External Communications Accessory Bus (when applicable)
Activate Latch Relay C on Trip	The trip conditions upon which Latch Relay C is activated: Long Delay Short Delay Instantaneous Ground Fault Ampere Unbalance Phase Loss Over Temperature Rating Plug External Communications Accessory Bus (when applicable)
Return to Metered Current Display	When set to Automatic, returns the trip unit display to the metered phase A, B and C current screen if the unit keypad is idle for 5 minutes.
INCOM Address	Communication address 001 through FFE.

Appendix G Auxiliary Relays

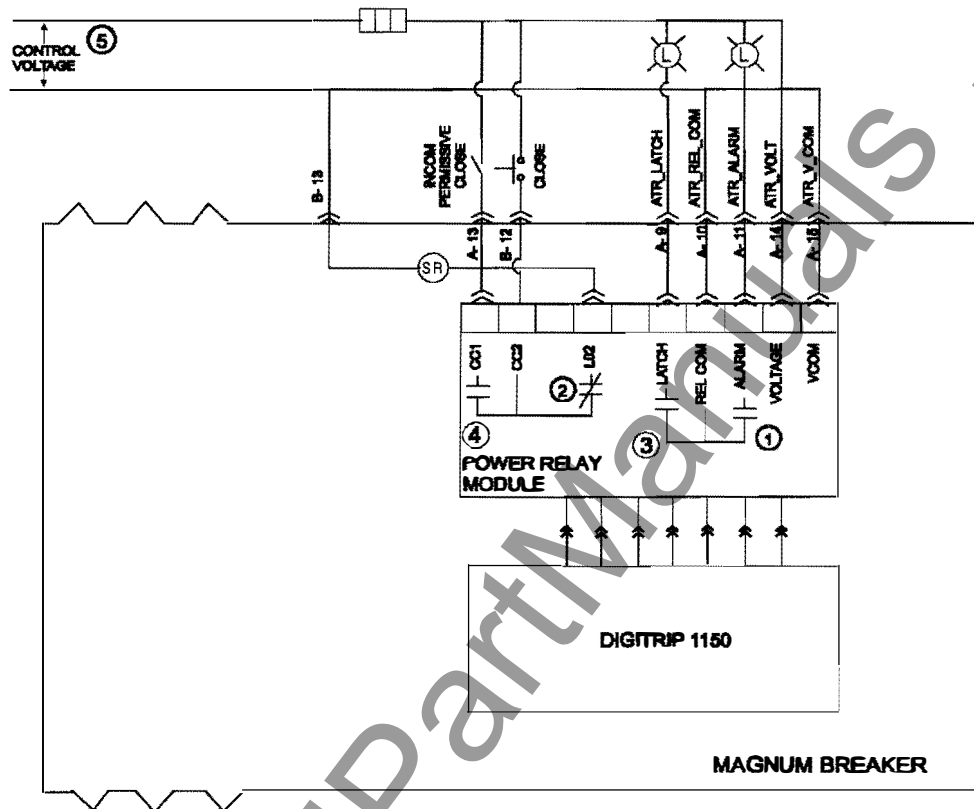

Available Input Voltage for Power / Relay Module (5)	Style Number
120 VAC +/- 10%	70C1002G01
230 VAC +/- 10%	70C1002G02
24/48 VDC +/- 10%	70C1005G01

Notes:

1. This relay contact is programmed via Digitrip 1150 as Relay A. See Appendix D-15.
2. This relay contact is programmed via Digitrip 1150 as Relay B. Block Close will prohibit the remote closing of the circuit breaker.
3. This relay contact is programmed via Digitrip 1150 as Relay C. This relay will hold contact status on loss of Auxiliary Power.
4. Contact rating (resistive load)
  - AC 0.5A @230 VAC
  - AC 1A @120 VAC
  - DC 1A @48 VDC
5. Verify Input voltage rating before energizing circuit.

## Appendix H Accessory Bus Digital Output Modules

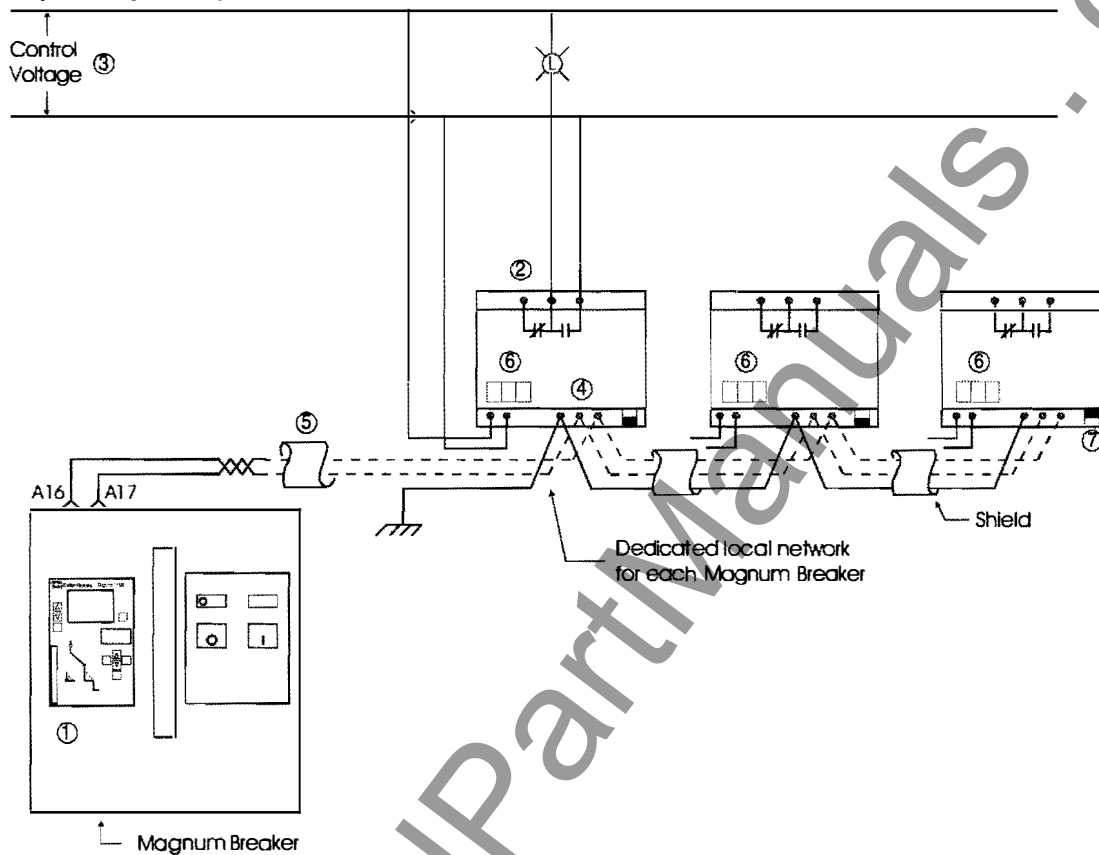

## Notes:

- ① The Digitrip 1150 front panel is used to program the external module and can be programmed for ReLaY FUNCTION of AUX Switch or BELL Alarm or DEAD man or WATCHDOG or ALARM (the Alarm relay tracks the function of the Aux ReLaY A programming) functions. See Appendix D-17.
- ② Each module has 4 relays. Each relay has a form C contact with each having a rating of 10A max @ 250 VAC.
- ③ Control voltage is 120 VAC  $\pm$  20%
- ④ Accessory Bus Modules use DIN rail mounting. Connector types are plug-in-Phoenix. Four form C contacts use 12 pin connectors. Power is 5 pin. Communication is 3 pin.
- ⑤ Cable is C-H style 2A957805G01 or Belden 9463 cable.
- ⑥ Set switch to corresponding address (001 through 004) programmed via the Digitrip front panel. See Appendix D-17.
- ⑦ Set switch up to insert 100 ohm terminating resistor on last relay of the network.

This instruction booklet is published solely for information purposes and should not be considered all inclusive. If further information is required, consult Cutler-Hammer, Inc.

The sale of the product shown in this literature is subject to the terms and conditions outlined in appropriate Cutler-Hammer, Inc., selling policies or other contractual agreements between the parties. This literature is not intended to and does not enlarge or add to any such contract. The sole source governing the rights and remedies of any purchaser of this equipment is the contract between the purchaser and Cutler-Hammer, Inc.

**NO WARRANTIES, EXPRESSED OR IMPLIED, INCLUDING WARRANTIES OF FITNESS FOR A PARTICULAR PURPOSE OR MERCHANTABILITY, OR WARRANTIES ARISING FROM THE COURSE OF DEALING OR USAGE OF TRADE, ARE MADE REGARDING THE INFORMATION, RECOMMENDATIONS, AND DESCRIPTIONS CONTAINED HEREIN.**

In no event will Cutler-Hammer, Inc., be responsible to the purchaser or user in contract, in tort (including negligence), strict liability, or otherwise for any special, indirect, incidental, or consequential damage or loss whatsoever, including, but not limited to, damage or loss of the use of equipment, plant or power system, cost of capital, loss of power, additional expenses in the use of existing power facilities, or claims against the purchaser or user by its customers resulting from the use of the information, recommendations, and descriptions contained herein.

www.ElectricalPartManuals.com

[www.ElectricalPartManuals.com](http://www.ElectricalPartManuals.com)

**Cutler-Hammer**

Pittsburgh, PA U.S.A.

Effective 03/2000

Printed in U.S.A.