

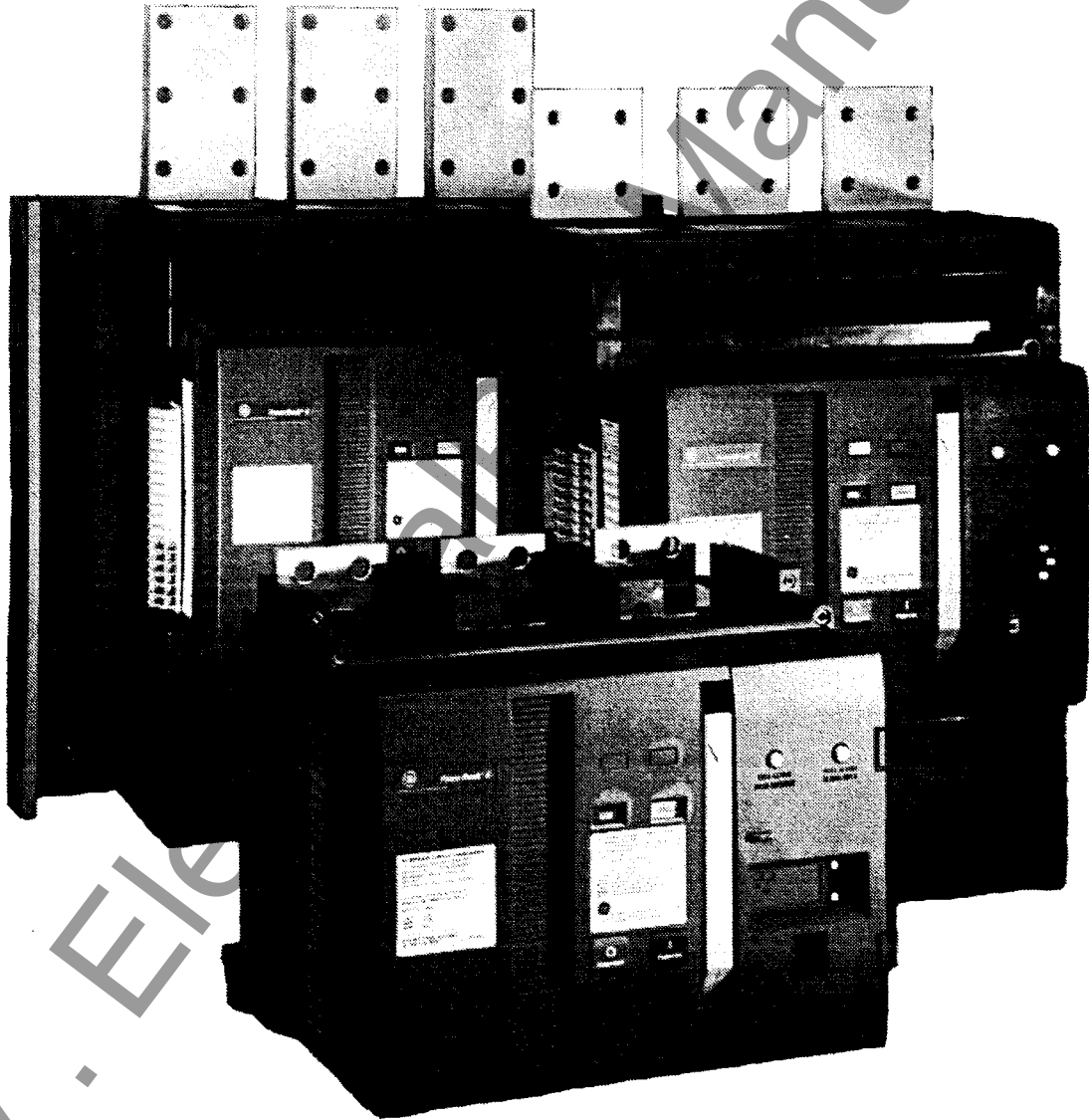

GEH-6270C

Power Break® II Circuit Breakers
800-4000 A Frames, 240-600 Vac

User's Guide



WWW.ELE

Manuals.COM

Power Break® II Circuit Breakers

Getting Started

Since this breaker is available in a variety of configurations, please take a moment to compare the catalog number of your purchased breaker with the catalog number key below. Installation of an incorrect breaker could result in misapplication, lack of system coordination, or reduced system selectivity. If you have any questions, call the GE Customer Support Center at 800-843-3742.

Code	Description	Function
S	Power Break® II	Breaker Family
S	Standard	Frame Type
H	Hi-Break	
B	Back-connected	Connection Type
D	Draw-out	
F	Front-connected	
08	800 A	Frame Rating
16	1600 A	
20	2000 A	
25	2500 A	
30	3000 A	
40	4000 A	
B2	up to 2000 A CTs	MicroVersaTrip Plus™ or MicroVersaTrip PM™ Trip Unit
B3	2500–3000 A CTs	
B4	4000 A CTs	
D2	up to 2000 A CTs	Power+™ Trip Unit
D3	2500–3000 A CTs	
D4	4000 A CTs	
02	200 A	Maximum CT Current Rating
04	400 A	
08	800 A	
10	1000 A	
16	1600 A	
20	2000 A	
25	2500 A	
30	3000 A	
40	4000 A	
H	Standard High-range instantaneous ^①	

① Available only with B-type Trip Units.

Power Break® II insulated-case circuit breaker catalog numbering system.

Example – a breaker with catalog number SHF16B210H has the following features:

- Power Break® II (S)
- Hi-Break® frame (H)
- Front-connected (F)
- 1600 A frame rating (16)
- Trip Unit with up to 2000 A CT(B2)
- 1000 A CT rating (10)
- High-range instantaneous CT (H)

GEH-6270C

WARNINGS, CAUTIONS, AND NOTES AS USED IN THIS PUBLICATION

WARNINGS

Warning notices are used in this publication to emphasize that hazardous voltages, currents, or other conditions that could cause personal injury are present in this equipment or may be associated with its use.

Warning notices are also used for situations in which inattention or lack of equipment knowledge could cause either personal injury or damage to equipment.

CAUTIONS

Caution notices are used for situations in which equipment might be damaged if care is not taken.

NOTES

Notes call attention to information that is especially significant to understanding and operating the equipment.

This document is based on information available at the time of its publication. While efforts have been made to ensure accuracy, the information contained herein does not cover all details or variations in hardware and software, nor does it provide for every possible contingency in connection with installation, operation, and maintenance. Features may be described herein that are not present in all hardware and software systems. GE Electrical Distribution & Control assumes no obligation of notice to holders of this document with respect to changes subsequently made.

GE Electrical Distribution & Control makes no representation or warranty, expressed, implied, or statutory, with respect to, and assumes no responsibility for the accuracy, completeness, sufficiency, or usefulness of the information contained herein. No warranties of merchantability or fitness for purpose shall apply.

The following are trademarks of GE Company:

Power Break®, MicroVersaTrip Plus™, MicroVersaTrip PM™, Power+™

Power Break® II Circuit Breakers

Table of Contents

Chapter 1. Introduction

1-1 Overview.....	1
1-2 Receiving the Breaker.....	1
Storage.....	1
1-3 Preparation for Installation.....	1
Bolted Electrical Connections.....	1
Panel Cutouts and Clearances.....	1
Accessory Installation.....	2
1-4 Breaker Installation.....	3

Chapter 2. Operation

2-1 Standard Features.....	4
2-2 Operating Instructions.....	4
Sequence of Operations.....	4
Operating Instructions for Manually Operated Breakers.....	4
Additional Instructions for Motor-Operated Breakers.....	6
Padlock Operation.....	6
Periodic Operational Checks.....	6
Wiring Notes.....	6
2-3 Trip Unit Setup.....	7

Chapter 3. Accessory Operation

3-1 Lug and Adapter Kits.....	8
Lug Kits (800–2000 A Frames).....	8
Lug Kits with Straps (2500–4000 A Frames).....	8
T-Studs.....	8
Adapter Kits.....	8
3-2 Plug-In Accessory Compartment.....	9
3-3 Bell Alarm—Alarm Only.....	9
Operation.....	9
3-4 Bell Alarm with Lockout.....	10
Operation.....	10
3-5 Shunt Trip.....	10
Operation.....	11
3-6 Shunt Trip with Lockout.....	11
Operation.....	12
3-6 Undervoltage Release.....	12
Operation.....	12
3-8 Accessory Configuration with MicroVersaTrip Plus™ and MicroVersaTrip PM™ Trip Units.....	12
Description of Switch Settings.....	13
3-9 Motor Operator Mechanism.....	13

Remote Operation.....	14
Automatic Operation.....	14
3-10 Remote Close.....	14
Remote Operation.....	14
3-11 Key Interlock Mounting Provision	14
Operation.....	15
3-12 Mechanical Counter.....	15
3-13 Auxiliary Switch Module.....	15
Operation.....	15
3-14 Door Interlock.....	16
Operation.....	16
3-15 Push Button Cover	17
Operation.....	17
Chapter 4. Trouble-Shooting Guide.....	18

Power Break® II Circuit Breakers

List of Figures

1. Locations of the front-panel escutcheon cutout and mounting holes, 800–2000 A frames.	2
2. Locations of the front-panel escutcheon cutout and mounting plate, 2500–4000 A frames.	2
3. Locations of the $\frac{1}{4}$ -20 x $\frac{3}{8}$ -inch deep screw inserts for mounting the breaker in equipment, 800–2000 A frames.	3
4. Locations of the $\frac{3}{8}$ -16 x $\frac{7}{16}$ -inch deep screw inserts for mounting the breaker in equipment, 2500–3000 A back-connected frames.	3
5. Locations of the $\frac{3}{4}$ -inch diameter through holes for mounting the breaker in equipment, 4000 A front-connected frame.	3
6. Front of the breaker, showing the locations of standard features.	4
7. Front of the breaker, with the Trip Unit and top cover removed.	4
8. Side view of the breaker, showing the padlock hasp extended.	6
9. Terminal block mounted on the right side of the breaker.	7
10. Locations of the plug-in accessory modules in the compartment on the front of the breaker.	9
11. Bell Alarm–Alarm Only module.	9
12. Bell Alarm–Alarm Only connections on the right terminal block.	9
13. Bell Alarm with Lockout module.	10
14. Bell Alarm with Lockout connections on the right terminal block.	10
15. Shunt Trip module.	10
16. Shunt Trip with Lockout module.	11
17. Undervoltage Release module.	12
18. Accessory configuration switch on the rear of MicroVersaTrip Plus™ and MicroVersaTrip PM™ Trip Units, showing the factory settings.	13
19. Motor Operator Mechanism.	13
20. Remote Close accessory.	14
21. Side view of the breaker, showing the padlock tab extended with the Key Interlock installed.	15
22. Mechanical Counter.	15
23. Auxiliary Switch Module with 12 switches.	16
25. Door Interlock accessory installed on the breaker.	17
26. Push Button Cover.	17

1. Weights of the various breaker frame sizes, with and without a motor operator.....	1
2. Bolt sizes and mounting torques for bus connections.....	1
3. Sequence of operations that may be performed with Power Break II circuit breakers.....	5
4. Accessory connections to the right terminal block B.....	7
5. Catalog numbers and wire sizes of Lug Kits for 800–2000 A frames.....	8
6. Catalog numbers and specifications of Lug Kits with Straps for 2500–4000 A frames.....	8
7. Catalog numbers and ratings of T-Studs.....	8
8. Catalog numbers and ratings of Adapter Kits.....	8
9. Bell Alarm–Alarm Only catalog numbers.....	9
10. Bell Alarm with Lockout catalog numbers.....	10
11. Catalog numbers and voltages for the Shunt Trip.....	11
12. Catalog numbers and voltages for the Shunt Trip with Lockout.....	11
13. Catalog numbers and voltages for the Undervoltage Release.....	12
14. Accessory configuration switch settings, including the factory defaults.....	13
15. Catalog numbers and operating voltages for the Motor Operator Mechanism.....	14
16. Catalog numbers and operating voltages for the Remote Close accessory.....	14
17. Catalog numbers of Key Interlock models.....	14
18. Auxiliary Switch Module catalog numbers.....	16
19. Auxiliary switch positions on the terminal board on the left side of the breaker, Block A.....	16

www.ElectricalPartManuals.com

1-1 Overview

Power Break® II insulated-case circuit breakers are designed to protect low-voltage power circuits and equipment. They are available with MicroVersaTrip Plus™, MicroVersaTrip PM™, and Power+™ Trip Units for fault detection.

1-2 Receiving the Breaker

Unpack the circuit breaker and inspect it for shipping damage. Ensure that the breaker has the proper current, voltage, and interruption ratings for the application by comparing the catalog number with the table in the Getting Started section on the inside front page.

The weights of the various frame sizes are listed in Table 1, for reference.

Frame Rating	Operation Type	Weight (lb)
800 A	Manual	71
	Electrical	80
1600 A or 2000 A	Manual	79
	Electrical	88
2500 A Front Connect	Manual	178
	Electrical	187
2500 A Back Connect	Manual	167
	Electrical	176
3000 A Front Connect	Manual	179
	Electrical	188
3000 A Back Connect	Manual	216
	Electrical	225
4000 A	Manual	320
	Electrical	329

Table 1. Weights of the various breaker frame sizes, with and without a motor operator.

Storage

The breaker should be placed in service immediately in its permanent location. However, if it must be stored for an indefinite period, it should be carefully protected against condensation, preferably by storage in a warm dry room. Circuit breakers for outdoor equipment should be stored in that equipment only when power is available and heaters are in operation, to prevent condensation.

The breaker should be stored in a clean location, free from corrosive gases or fumes. In particular, protect the breaker from moisture and cement dust, as that combination may be corrosive.

If the breaker is stored for any length of time, it should be inspected periodically to ensure good mechanical condition.

1-3 Preparation for Installation

Bolted Electrical Connections

Using an industry-accepted solvent, remove any foreign material from the line and load strap surfaces and the corresponding surfaces of the connecting bus. Ensure that the mating surfaces are smooth and free of burrs and nicks.

Place the bus connections in position and align the mounting holes. Insert and fasten the mounting bolts and washers according to specifications in Table 2.

Breaker Frame	Bus Connection	
	Bolt Diam.	Torque (in-lb)
800A	(1) 1/2 in.	300
1600-2000A	(2) 1/2 in.	300
2500 A	(4) 3/8 in.	225
3000 A	(4) 3/8 in.	225
4000 A	(6) 1/2 in.	300

Table 2. Bolt sizes and mounting torques for bus connections.

Panel Cutouts and Clearances

Use the following information to prepare the equipment and assure proper clearances for installation and operation of the breaker.

Figures 1 and 2 show the front-panel escutcheon cutout patterns and the locations of the breaker mounting bolts. The standard door cutout dimensions require a trim plate on the breaker. The optional dimensions are for flush front or non hinged door construction and the trim plate may be omitted. Ventilation cutouts are required for stationary-mounted breakers rated 1600 A and larger and for draw-out breakers rated 2000 A and larger. Ventilation cutouts are *not* required for draw-out-mounted 800 A or 1600 A frame breakers or for stationary-mounted 800 A frame breakers.

Power Break® II Circuit Breakers

Chapter 1. Introduction

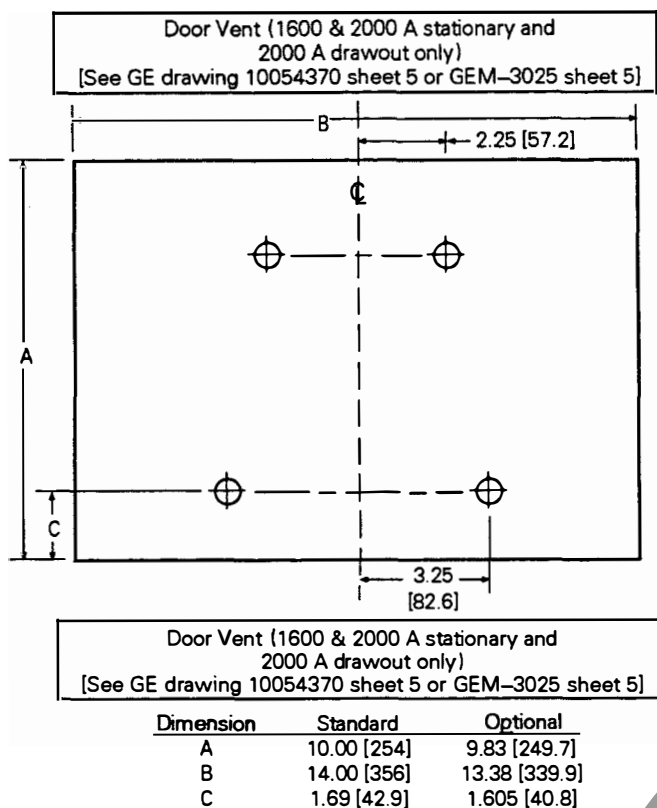

Figure 1. Locations of the front-panel escutcheon cutout and mounting holes, 800-2000 A frames.

Because of arc chamber venting, the minimum through-air distance from the top of the breaker's molded case to grounded metal for 800-2000 A breakers is 4.50 inches [114 mm] in an area 5.31 inches x 16.00 inches [135 mm x 406 mm], centered over the vent screens. (Refer to outline drawings 10054370, Sheets 1-5, for details.)

For 2500-4000 A breakers, the minimum through-air distance from the top of the breaker's molded case to grounded metal is 8.00 inches [203 mm] in an area 9.00 inches x 16.00 inches [227 mm x 406 mm], over the vent screens. (Refer to outline drawings 10055629, Sheets 1-7, for details.)

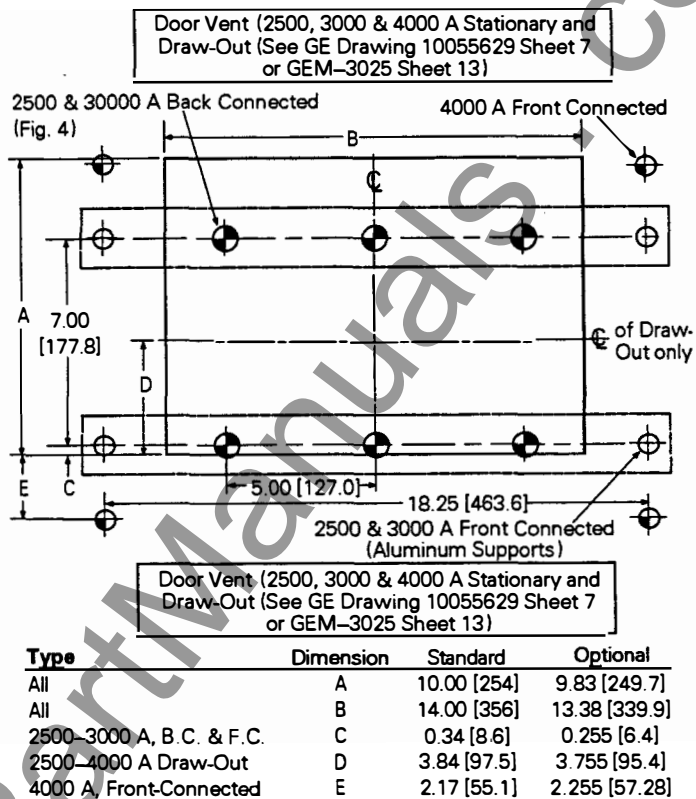

Figure 2. Locations of the front-panel escutcheon cutout and mounting plate, 2500-4000 A frames.

Accessory Installation

The following accessories may be installed in the breaker. Refer to Chapter 3 of this publication for catalog numbers and to the instruction sheet supplied with each accessory for installation instructions.

- Lugs and Adapters
- Motor Operator Mechanism
- Remote Close
- Undervoltage Release
- Shunt Trip
- Shunt Trip with Lockout
- Bell Alarm-Alarm Only
- Bell Alarm with Lockout
- Auxiliary Switch Module
- Mechanical Counter
- Key Interlock Mounting Provision
- Push Button Cover
- Door Interlock
- Mechanical Interlock

1-4 Breaker Installation

Ensure that all accessory connections are secure. Line up the bolt holes in the enclosure with the attachment points on the breaker, illustrated in Figures 3, 4 and 5, insert the bolts and tighten. Use *nonmagnetic* material in the area between the line and load terminals to support the breaker.

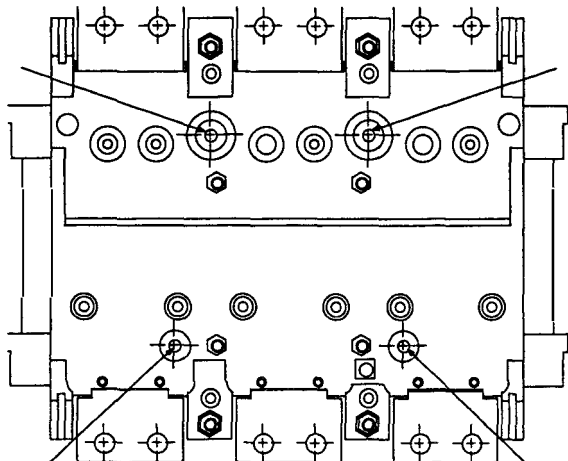

Figure 3. Locations of the $\frac{1}{4}$ -20 x $\frac{3}{8}$ -inch deep screw inserts for mounting the breaker in equipment, 800–2000 A frames.

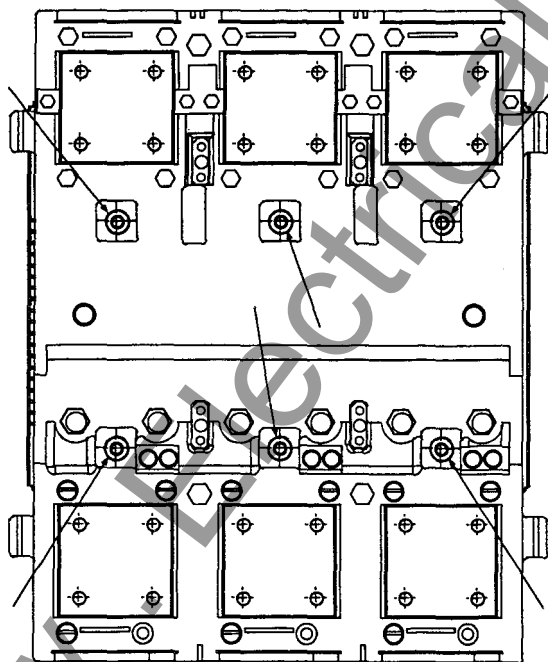

Figure 4. Locations of the $\frac{3}{8}$ -16 x $\frac{7}{16}$ -inch deep screw inserts for mounting the breaker in equipment, 2500–3000 A back-connected frames.

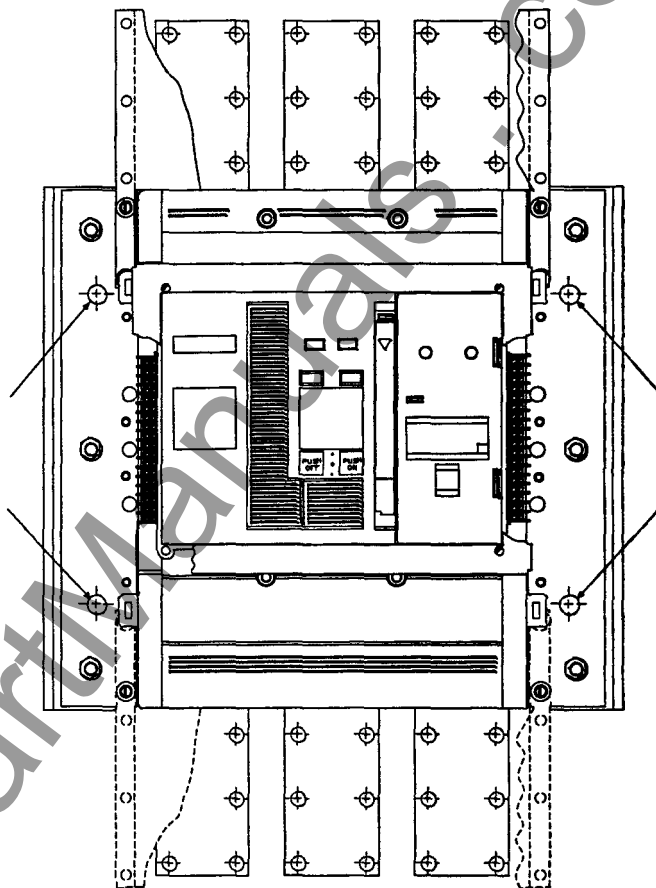

Figure 5. Locations of the $\frac{3}{4}$ -inch diameter through holes for mounting the breaker in equipment, 4000 A front-connected frame.

Power Break® II Circuit Breakers

Chapter 2. Operation

2-1 Standard Features

Power Break II circuit breakers are equipped with the following standard features. The letters are keyed to the breaker photographs in Figures 6 and 7.

- A Indicator: ON – Red
OFF – Green
- B Indicator: CHARGED – Yellow
DISCHARGED – White
- C ON button
- D OFF button
- E Manual charging handle
- F Integral 36-point terminal block (12 auxiliary switches, A-B type), Block “A”
- G Integral 36-point terminal block (all other connections), Block “B”
- H Sealable hinged cover
- I Cover mounting screws (4)
- K Trip Unit interchangeable rating plug
- L Test set connection port
- M Standard padlock provision
- N Dust-resistant ventilation slots

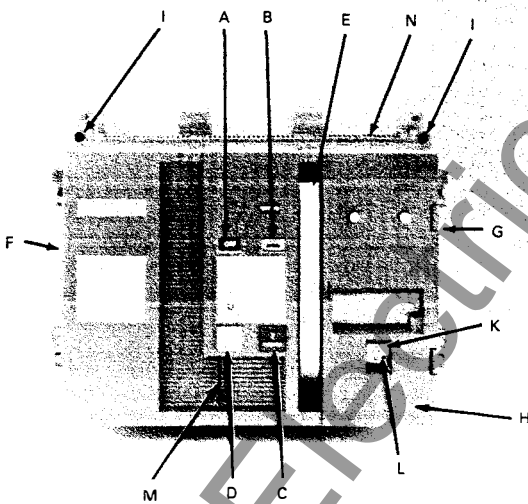

Figure 6. Front of the breaker, showing the locations of standard features.

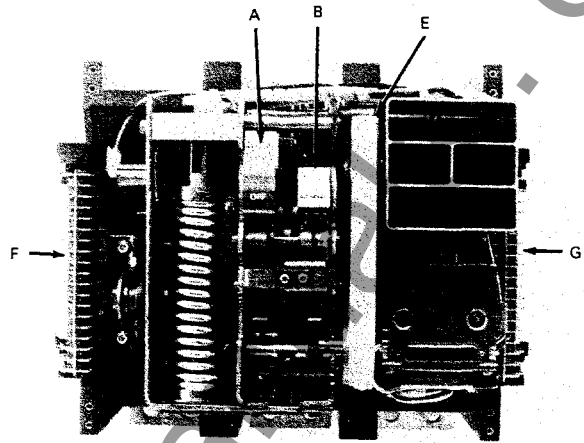

Figure 7. Front of the breaker, with the Trip Unit and top cover removed.

2-2 Operating Instructions

Sequence of Operations

The sequence of operations that may be performed on the circuit breaker are listed in Table 3. Refer to Chapter 3 for information about accessory operation.

Operating Instructions for Manually Operated Breakers

Charging the Mechanism Springs

Pull the operating handle down about 90° (until it stops). Repeat five more times to fully charge the springs. *This will not close the breaker contacts.* The charge indicator will show **CHARGED** on a yellow background. When the springs are fully charged, the handle locks in the stored position.

NOTE: The breaker cannot be closed unless the springs are fully charged and the handle is stored fully in.

NOTE: La fermeture du disjoncteur ne peut être réalisée à moins que les ressorts soient réarmés tout à fait, et le levier est complètement remis à la position d'emmagasinage.

On/Off Indicator	Charge Indicator	Main Breaker Contacts	Condition of Charging Springs	Next Permissible Operating Function
OFF	DISCHARGED	Open	Discharged	Mechanism may be charged
OFF	CHARGED	Open	Charged	Contacts may be closed
ON	DISCHARGED	Closed	Discharged	Mechanism may be recharged or Contacts may be opened
ON	CHARGED	Closed	Charged	Contacts may be opened

Table 3. Sequence of operations that may be performed with Power Break II circuit breakers.

Closing the Breaker

Close the breaker contacts with either of the following methods:

- Depress the ON button on the front of the breaker.
- Energize the (optional) Remote Close accessory by applying rated voltage to terminals 16 and 34 on terminal block B.

CAUTION: The main breaker contacts cannot be closed if the breaker latch is held in the tripped position by any of the following conditions:

- The Bell Alarm with Lockout was not reset after an overcurrent lockout.
- The Undervoltage Release is not energized.
- The Shunt Trip with Lockout is energized.

These conditions must be corrected before the breaker can be closed.

ATTENTION: Les contacts de disjoncteur principal peuvent être fermés où le loquet de disjoncteur est maintenu en position déclenchée à cause de toute des conditions suivantes:

- Si la réarmature du déclencheur n’est pas réalisée après le verrouillage en position “ouvert” provenant du courant de surcharge.
- Si le minimum de tension (UVR) n’est pas sous tension.
- Le déclenchement shunt avec blocage est actionné.

Ces conditions doivent être corrigées avant le disjoncteur peut être fermé.

CAUTION: If the breaker latch is held in the tripped position by any of the following conditions and an attempt is made to close the main breaker contacts, the mechanism will “crash” (the closing springs discharge with no motion of the breaker contact arms). The circuit breaker has been designed and tested to withstand more than 100 crash operations, but repeated attempts to close a locked-out breaker will damage the breaker mechanism.

- The Key interlock or padlock is in the locked OFF condition.
- The draw-out interlock is engaged with the carriage between the TEST and CONNECTED positions.
- The walking beam interlock or mechanical interlock is activated.

ATTENTION: Si le cliquet du disjoncteur est tenu en position de déclenchement dans n’importe quelle des conditions suivantes et que l’on tente de fermer les contacts du disjoncteur principal, le mécanisme subira un “crash” (les ressorts de fermeture se détendent sans que les bras des contacts du disjoncteur ne bougent). Le disjoncteur a été conçu et testé pour résister à plus de 100 opérations de type “crash,” cependant des tentatives répétées ayant pour but de fermer un disjoncteur bloqué endommageront le mécanisme du disjoncteur.

- Si le verrou de clé ou le cadenas est verrouillé en position OFF.
- Si le chariot du verrou débrochable est localisé entre les positions TEST et CONNECTED.
- L’enclenchement par support mobile ou enclenchement mécanique est activé.

Power Break® II Circuit Breakers

Chapter 2. Operation

Opening the Breaker

Open the breaker contacts with either of the following methods:

- Depress the OFF button on the front of the breaker.
- Energize the (optional) Shunt Trip or Shunt Trip with Lockout accessory or de-energize the (optional) Undervoltage Release accessory.

Additional Instructions for Motor-Operated Breakers

Charging the Mechanism Springs

The mechanism closing springs may also be charged by the following method:

- Short terminals 17 and 35 on the right terminal block, with a push button or similar device, for a minimum of five seconds.
- If power is lost during the charge cycle, finish charging the springs by cycling the charging handle until the indicator shows **CHARGED** on a yellow background. When the springs are fully charged, the handle locks in the stored position.

Automatic Operation

Connect terminals 17 and 35 on the terminal block on the right side of the breaker with a jumper wire. The Motor Operator will automatically recharge the breaker closing springs whenever the breaker closes.

CAUTION: Do not wire breakers for automatic close.

ATTENTION: Ne pas connecter les disjoncteurs pour la fermeture automatique.

Padlock Operation

The padlock prevents the breaker from closing by holding the trip latch in the tripped position. To install the padlock, use the following procedure:

1. Trip the breaker (press the OFF button).
2. Grasp the padlock tab (see Figure 6) and pull it out until it is fully extended, as illustrated in Figure 8. Note that if the breaker contacts are closed, the padlock tab will not extend.
3. Insert the padlock; the breaker will not close.

As many as three $\frac{1}{4}$ " to $\frac{3}{8}$ " padlocks may be attached at one time.

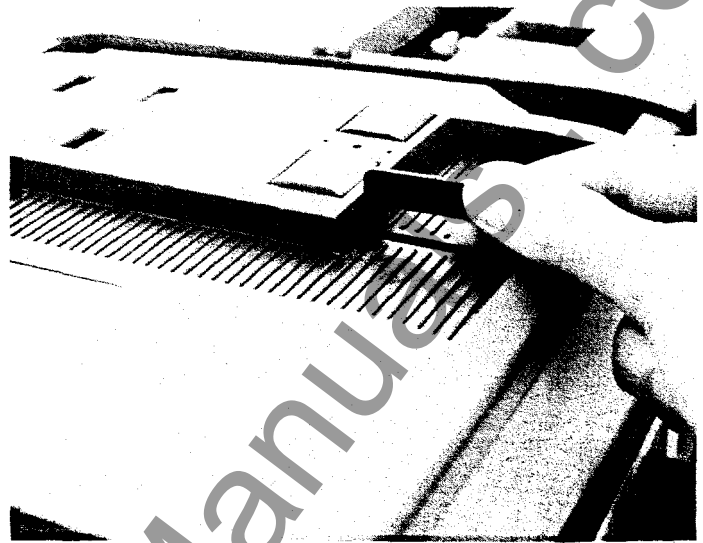

Figure 8. Side view of the breaker, showing the padlock tab extended.

Periodic Operational Checks

Approximately once a year, verify that the breaker is operating correctly by opening and closing the mechanism.

Wiring Notes

Figure 9 illustrates the terminal block installed on the right side of the breaker. Table 4 lists the device connections to the terminal block. Each terminal point will accept the following connections:

- Bare stripped wire – one #12 AWG or two #14 AWG.
- Ring or spade connectors – two per terminal.

The terminal screws should be tightened to 7–9 in-lb torque.

The left terminal block is blank unless the optional Auxiliary Switch Module accessory is ordered. See Table 16 for the device connections to the Auxiliary Switch Module terminal block.

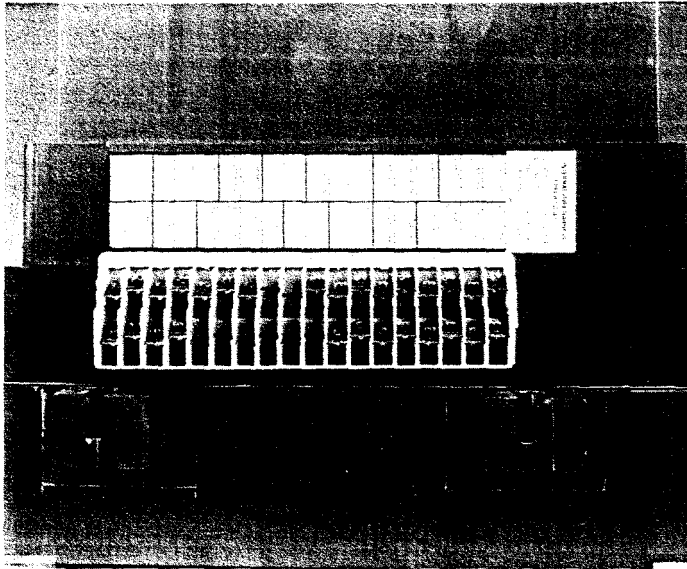

Figure 9. Terminal block mounted on the right side of the breaker.

2-3 Trip Unit Setup

See GEH-6273 for detailed instructions on setting up MicroVersaTrip Plus and MicroVersaTrip PM Trip Units.

The procedure for setting up the accessory configuration DIP switch on the rear of the Trip Unit is described in Chapter 3 of this publication.

See DEH-049 for detailed instructions on setting up Power+ Trip Units.

Terminal	Terminal
18 Motor Operator +	36 Motor Operator –
17 Remote Charge ①	35 Remote Charge ①
16 Remote Close +	34 Remote Close –
15 Bell Alarm only Com	33 Charge Indicator
14 Bell Alarm only NO	32 Shunt Trip
13 Bell Alarm only NC	31 Shunt Trip
12 Lockout Common	30 Undervoltage Release
11 Lockout NO	29 Undervoltage Release
10 Lockout NC	28 Reserved
9 Reserved	27 Reserved
8 Reserved	26 Zone-Select Input –
7 commnet –	25 Zone-Select Input +
6 commnet +	24 Zone-Select Output –
5 C Phase Volts	23 Zone-Select Output +
4 B Phase Volts	22 Draw-Out Switch ②
3 A Phase volts	21 Draw-Out Switch ②
2 24 Vdc –	20 N Tap
1 24 Vdc +	19 N Common

① Do not apply voltage; see wiring diagram.

② Not a user connection.

Table 4. Accessory connections to the right-side terminal block B.

Power Break® II Circuit Breakers

Chapter 3. Accessory Operation

Following are the operation procedures for each of the available breaker accessories. See the user guides supplied with the accessories for installation and removal.

3-1 Lug and Adapter Kits

Lug Kits (800–2000 A Frames)

Direct-mounting lugs bolt directly to the line or load strap of the circuit breaker. Order one Lug Kit per line or load pole. Lug Kit catalog numbers and wire sizes are listed in Table 5.

Cat. No.	Wires	Wire Sizes	Amps
TPLUG106	1	#2–600 kcmil CU/AL	400
	2	1/0–250 kcmil CU/AL	
TPLUG206	2	#2–600 kcmil CU/AL	600
TPLUG308	3	300–750 kcmil CU/AL	800
TPLUG408	4	500–800 kcmil CU/AL	1600

Table 5. Catalog numbers and wire sizes of Lug Kits for 800–2000 A frames.

Lug Kits with Straps (2500–4000 A Frames)

Lug Kits with Straps include copper straps that connect directly to breaker T-studs (must be ordered separately) to provide proper phase clearances for mounting lugs. Order one Lug Kit with Straps per line or load side. Catalog numbers are listed in Table 6.

Cat. No.	Lugs per Kit	Max. Wires per Pole	Wire Range	Frame Size (A)	Max. Amps
TSLUG08	9	3	3/0–800 kcmil Cu/Al	2500 or 3000	800
TSLUG12	12	4			1200
TSLUG16	15	5		1600	
TSLUG20	18	6		2000	
TSLUG25	21	7		2500	
TSLUG30	27	9		3000	3000
TSLUG40	33	11	4000	4000	

Table 6. Catalog numbers and specifications of Lug Kits with Straps for 2500–4000 A frames.

T-Studs

T-Studs bolt directly to the line or load terminals of the breaker. Order one T-Stud per line or load pole. T-Stud catalog numbers and ratings are listed in Table 7.

Cat. No.	Material	Frame (A)	Max. Amps	Breaker Connect
SP08FCA	Al	800	800	Front
SP08FCC	Cu	800	800	Front
SP20FCA	Al	1600–2000	2000	Front
SP20FCC	Cu	1600–2000	2000	Front
SPS20FCA	Al	2500	2000	Front
SPS20BCA	Al	2500	2000	Back
SPS25FCC	Cu	2500	2500	Front
SPS25BCC	Cu	2500	2500	Back
SPS30FCC	Cu	3000	3000	Front
N/A ^①	Cu	3000	3000	Back
SPS40FCC	Cu	4000	4000	Front
SPS40LFCC ^②	Cu	4000	4000	Front

① Integral T-Studs are not removable on 3000 A back-connected breakers.

② Long studs may be used in place of or alternated with SPS40FCC if desired.

Table 7. Catalog numbers and ratings of T-Studs.

Adapter Kits

Adapter Kits bolt directly to the line or load terminals on the rear of the breaker. They provide proper phase-to-phase clearances for mounting lugs or busbars. Order one Adapter Kit per three-phase line or load side. Lugs must be ordered separately. Adapter Kit catalog numbers and ratings are listed in Table 8.

Cat. No.	Frame (A)	Lug Oding Information (Per Line or Load Side)
TPLUGA08	800	9 TPLUG108 ^② Lugs or 9 Crimp Lugs ^③
TPLUGA16 ^①	1600	18 TPLUG108 ^② Lugs or 18 Crimp Lugs ^③
TPLUGA20 ^①	1600–2000	18 TPLUG108 ^② Lugs or 18 Crimp Lugs ^③

① Premounts in equipment, allowing cabling or bussing to be completed before breaker mounting.

② 3/0–800 kcmil Cu/Al wire range.

③ Anderson No. VCEL-075-12H1 or equivalent.

Table 8. Catalog numbers and ratings of Adapter Kits.

3-2 Plug-In Accessory Compartment

Several of the accessories are installed in the accessory compartment on the front of the breaker. Figure 10 illustrates this compartment and the locations of each of the plug-in accessory modules.

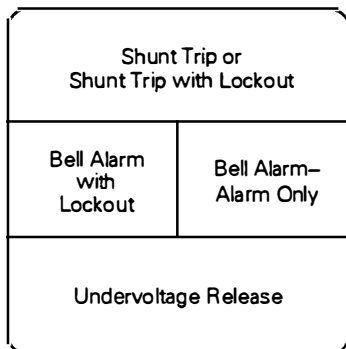

Figure 10. Locations of the plug-in accessory modules in the compartment on the front of the breaker.

3-3 Bell Alarm-Alarm Only

The Bell Alarm-Alarm Only module, shown in Figure 11, provides a switch to remotely indicate that the circuit breaker has tripped. It is reset either automatically when the circuit breaker is reclosed or manually when the reset button on the front of the Bell Alarm-Alarm Only module is pressed.



Figure 11. Bell Alarm-Alarm Only module.

In addition to activation by protection trips, the Bell Alarm-Alarm Only accessory module can be set up to interact with other Power Break II accessories, when used with a MicroVersaTrip Plus or MicroVersaTrip PM Trip Unit. DIP switches on the rear of the MicroVersaTrip Plus or MicroVersaTrip PM Trip Unit can configure the Bell Alarm-Alarm Only accessory to

activate when a Shunt Trip or Undervoltage Release trip occurs.

The Power+ Trip Unit activates the Bell Alarm-Alarm Only for protection trips only.

The catalog numbers for the Bell Alarm-Alarm Only are listed in Table 9. For installation instructions see GEH-6275.

Catalog No.	Contact Rating
SPBAA240	6 A at 240 Vac 0.25 A at 250 Vdc 0.50 A at 125 Vdc
SPBAA600 ^①	6 A at 600 Vac 0.25 A at 250 Vdc 0.50 A at 125 Vdc

^① 600 V version is not UL listed.

Table 9. Bell Alarm-Alarm Only catalog numbers.

Operation

The Bell Alarm-Alarm Only provides normally open (NO) and normally closed (NC) outputs available at the terminal block on the right side of the breaker, as illustrated in Figure 12. The outputs change state whenever a breaker trip occurs. This trip can be caused by an overcurrent condition detected by the Trip Unit. This trip can also be generated by the Shunt Trip or Undervoltage Release, if installed with a MicroVersaTrip Plus or MicroVersaTrip PM Trip Unit, and if the appropriate DIP switches have been set on the back of the Trip Unit (see Section 3-8, *Accessory Configuration at the Trip Unit*).

The Bell Alarm-Alarm Only accessory resets automatically, returning the outputs to their normal configuration, when the breaker is reclosed. The Bell Alarm-Alarm Only can also be reset manually, before the breaker is reclosed, by pressing the reset button on the front of the module.

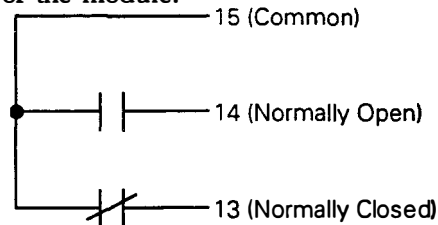

Figure 12. Bell Alarm-Alarm Only connections on the right terminal block. The contacts are shown in the reset state.

Power Break® II Circuit Breakers

Chapter 3. Accessory Operation

3-4 Bell Alarm with Lockout

The Bell Alarm with Lockout module, shown in Figure 13, prevents reclosing of the breaker after a trip until the Bell Alarm with Lockout is reset. It can only be reset by pressing the button on the top of the module. This module also provides a switch to remotely indicate that the circuit breaker has tripped.



Figure 13. Bell Alarm with Lockout module.

In addition to activation by protection trips, the Bell Alarm with Lockout accessory module can be set up to interact with other Power Break II accessories when used with a MicroVersaTrip Plus or MicroVersaTrip PM Trip Unit. DIP switches on the rear of the MicroVersaTrip Plus or MicroVersaTrip PM Trip Unit can configure the Bell Alarm with Lockout accessory to activate when a Shunt Trip or Undervoltage Release trip occurs.

The Power+ Trip Unit activates the Bell Alarm with Lockout for protection trips only.

The catalog numbers for the Bell Alarm with Lockout are listed in Table 10. For installation instructions see GEH-6278.

Catalog No.	Contact Rating
SPBAL240	6 A at 240 Vac 0.25 A at 250 Vdc 0.50 A at 125 Vdc
SPBAL600 ^①	6 A at 600 Vac 0.25 A at 250 Vdc 0.50 A at 125 Vdc

^① The 600 V version is not UL listed.

Table 10. Bell Alarm with Lockout catalog numbers.

Operation

The Bell Alarm with Lockout prevents reclosing of the breaker after a trip until the reset button on the front

of the module is pressed. This trip can be caused by an overcurrent condition detected by the Trip Unit. This trip can also be generated by the Shunt Trip, Shunt Trip with Lockout, or Undervoltage Release, if installed with a MicroVersaTrip Plus or MicroVersaTrip PM Trip Unit, and if the appropriate DIP switches have been set on the back of the Trip Unit (see Section 3-8, *Accessory Configuration at the Trip Unit*).

In addition, the Bell Alarm with Lockout provides normally open (NO) and normally closed (NC) alarm outputs available at the terminal block on the right side of the breaker, as illustrated in Figure 14. These outputs are returned to their normal state when the Bell Alarm with Lockout reset button is firmly pressed.

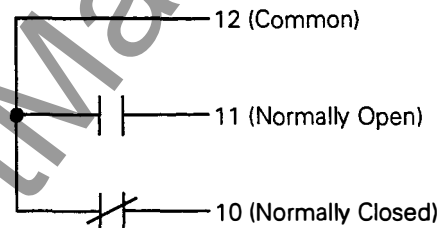

Figure 14. Bell Alarm with Lockout connections on the right terminal block. The contacts are shown in the reset state.

3-5 Shunt Trip

The Shunt Trip module, shown in Figure 15, allows the breaker to be tripped electrically from a remote location.

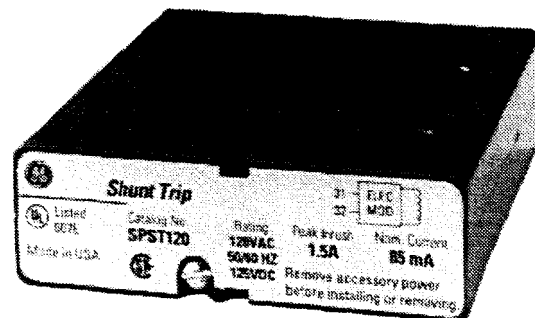

Figure 15. Shunt Trip module.

In addition to providing a trip signal to the breaker, the Shunt Trip accessory module can be set up to interact with other Power Break II accessories, when used with a MicroVersaTrip Plus or MicroVersaTrip PM Trip Unit. DIP switches on the rear of the Trip Unit can configure the Shunt Trip accessory to activate a Bell Alarm-Alarm Only accessory or a Bell Alarm with

Lockout accessory when a Shunt trip occurs. (See Section 3-8, *Accessory Configuration at the Trip Unit.*) If the breaker is equipped with a Power+ Trip Unit, it is configured so that only protection trips will activate a Bell Alarm—Alarm Only or Bell Alarm with Lockout.

The catalog numbers for the Shunt Trip for various voltage applications are listed in Table 11. For installation instructions see GEH-6284 or GEH-6519.

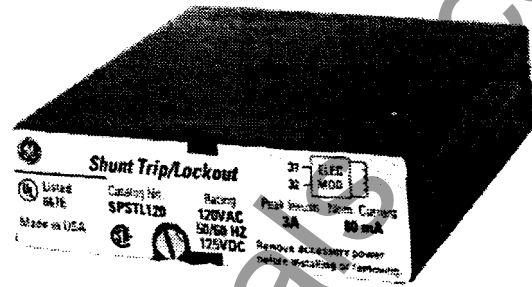

Figure 16. Shunt Trip with Lockout module.

Catalog Number	Voltage Rating ①	Peak Inrush Current, A ②	Nominal RMS Current, mA
SPST012	12 Vdc	3.0	200
SPST024	24 Vac 24 Vdc	1.5	140
SPST048	48 Vac 48 Vdc	1.5	110
SPST120	120 Vac 125 Vdc	1.5	85
SPST208	208 Vac	1.5	50
SPST240	240 Vac 250 Vdc	1.5	40
SPST480 ③	480 Vac	0.375	21
SPST600 ③	600 Vac	0.3	17

① 24–600 Vac devices are rated for 50/60 Hz.

② Peak inrush current is present for 2–6 ms after activation. This number is provided so that fuses and supplies can be chosen appropriately.

③ Ratings for 480 Vac and 600 Vac devices are at the input of the upstream transformer, included with the accessory and specified in GEH-6519, which powers the device. For voltage and current ratings at the breaker terminal block, see SPST120.

Table 11. Catalog numbers and voltages for the Shunt Trip.

Operation

Apply control voltage to terminals 31 and 32 of the terminal strip on the right side of the breaker to trip the circuit breaker. The Shunt Trip will cause the circuit breaker to trip when the control voltage is greater than 75% of the dc-rated value or 55% of the ac-rated value.

3-6 Shunt Trip with Lockout

The Shunt Trip with Lockout module, shown in Figure 16, allows the breaker to be tripped electrically from a remote location and prevents the circuit breaker from closing while the accessory is energized.

In addition to providing a trip signal to the breaker, the Shunt Trip with Lockout accessory module can be set up to interact with other Power Break II accessories, when used with a MicroVersaTrip Plus or MicroVersaTrip PM Trip Unit. DIP switches on the rear of the Trip Unit can configure the Shunt Trip with Lockout accessory to activate a Bell Alarm—Alarm Only accessory or a Bell Alarm with Lockout accessory when a Shunt trip occurs. (See Section 3-8, *Accessory Configuration at the Trip Unit.*) If the breaker is equipped with a Power+ Trip Unit, it is configured so that only protection trips will activate a Bell Alarm—Alarm Only or Bell Alarm with Lockout.

The catalog numbers for the Shunt Trip for various voltage applications are listed in Table 12. For installation instructions see GEH-6284 or GEH-6519.

Catalog Number	Voltage Rating ①	Peak Inrush Current, A ②	Nominal RMS Current, mA
SPSTL012	12 Vdc	19	300
SPSTL024	24 Vac 24 Vdc	15	300
SPSTL048	48 Vac 48 Vdc	7.5	200
SPSTL120	120 Vac 125 Vdc	3.0	80
SPSTL208	208 Vac	1.9	60
SPSTL240	240 Vac 250 Vdc	1.5	45
SPSTL480 ③	480 Vac	0.75	20
SPSTL600 ③	600 Vac	0.60	16

① 24–600 Vac devices are rated for 50/60 Hz.

② Peak inrush current is present for 2–6 ms after activation. This number is provided so that fuses and supplies can be chosen appropriately.

③ Ratings for 480 Vac and 600 Vac devices are at the input of the upstream transformer, included with the accessory and specified in GEH-6519, which powers the device. For voltage and current ratings at the breaker terminal block, see SPSTL120.

Table 12. Catalog numbers and voltages for the Shunt Trip with Lockout

Power Break® II Circuit Breakers

Chapter 3. Accessory Operation

Operation

Apply control voltages to terminals 31 and 32 of the terminal strip on the right side of the breaker to trip the circuit breaker. The Shunt Trip with Lockout will cause the circuit breaker to trip when the control voltage is greater than 75% of the dc-rated value or 55% of the ac-rated value.

3-7 Undervoltage Release

The Undervoltage Release (UVR) module, shown in Figure 17, trips the circuit breaker when the input control voltage drops to 35–60% of its rated value and prevents an open breaker from closing until the input control voltage is greater than 80% of the rated value.

In addition to providing a trip signal to the breaker, the UVR accessory module can be set up to interact with other Power Break II accessories, when used with a MicroVersaTrip Plus or MicroVersaTrip PM Trip Unit. DIP switches on the rear of the Trip Unit can configure the UVR accessory to activate a Bell Alarm–Alarm Only accessory or a Bell Alarm with Lockout accessory when a UVR trip occurs. (See Section 3-8, *Accessory Configuration at the Trip Unit*.) If the breaker is equipped with a Power+ Trip Unit, it is configured so that only protection trips will activate a Bell Alarm–Alarm Only or Bell Alarm with Lockout.

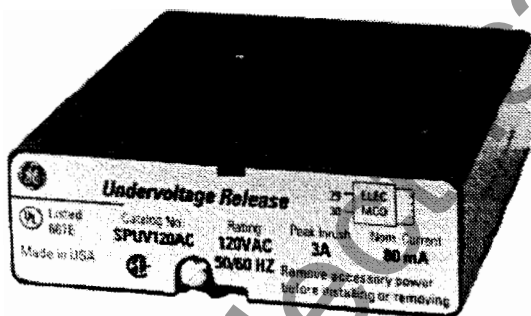

Figure 17. Undervoltage Release module.

The catalog numbers for the UVR for various voltage applications are listed in Table 13. For installation instructions see GEH-6285 or GEH-6520.

Catalog Number	Voltage Rating ^①	Peak Inrush Current, A ^②	Nominal RMS Current, mA
SPUV012DC	12 Vdc	19	300
SPUV024DC	24 Vdc	15	140
SPUV048DC	48 Vdc	7.5	70
SPUV125DC	125 Vdc	3	30
SPUV250DC	250 Vdc	1.5	15
SPUV024AC	24 Vac	15	370
SPUV048AC	48 Vac	7.5	210
SPUV120AC	120 Vac	3	80
SPUV208AC	208 Vac	1.9	60
SPUV240AC	240 Vac	1.5	45
SPUV480AC	480 Vac	0.75	20
SPUV600AC	600 Vac	0.60	16

^① 24–600 Vac devices are rated for 50/60 Hz.

^② Peak inrush current is present for 2–6 ms after activation. This number is provided so that fuses and supplies can be chosen appropriately.

^③ Ratings for 480 Vac and 600 Vac devices are at the input of the upstream transformer, included with the accessory and specified in GEH-6520, which powers the device. For voltage and current ratings at the breaker terminal block, see SPUV120AC.

Table 13. Catalog numbers and voltages for the Undervoltage Release.

Operation

Apply control voltage to terminals 29 and 30 of the terminal strip on the right side of the breaker. When the applied control voltage is above 80% of the UVR's rated value, the breaker can be closed. When the voltage drops to 35–60% of the rated value, the UVR will trip the breaker.

3-8 Accessory Configuration with MicroVersaTrip Plus™ and MicroVersaTrip PM™ Trip Units

MicroVersaTrip Plus and MicroVersaTrip PM Trip Units have a six-position DIP switch module on the rear of the unit that controls the configuration of the Power Break II integrated accessories. These switches can be set up to define the types of signals (protection trip, Shunt trip, or Undervoltage Release trip) that activate the Bell Alarm–Alarm Only and Bell Alarm with Lockout accessories on the Power Break II breaker. Each of the six switches enables or disables a different path to activate these accessories from the different types of trip signals.

The MicroVersaTrip Plus and MicroVersaTrip PM Trip Unit DIP switches are illustrated in Figure 18,

with the factory settings shown. Table 14 lists the switch functions.

There are no DIP switches on the rear of the Power+ Trip Unit, which performs according to the default settings in Table 14. Therefore, only protection trips activate Bell Alarm–Alarm Only and Bell Alarm with Lockout accessories when a Power+ Trip Unit is installed in the breaker.

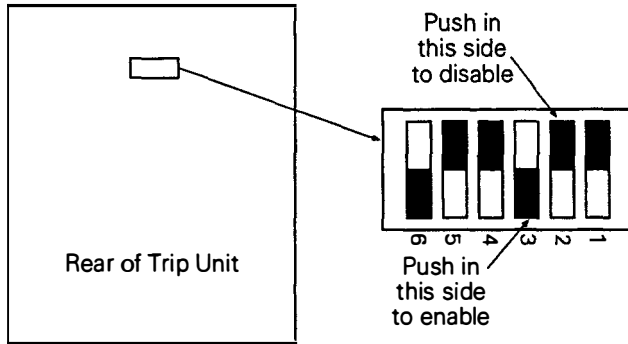

Figure 18. Accessory configuration switch on the rear of MicroVersaTrip Plus™ and MicroVersaTrip PM™ Trip Units, showing the factory settings (solid part indicates that the switch is pushed in on that side).

Switch	Factory Setting	Function
1	Disabled	Shunt trip activates Bell Alarm–Alarm Only
2	Disabled	UVR trip activates Bell Alarm–Alarm Only
3	Enabled	Protection trip activates Bell Alarm–Alarm Only
4	Disabled	Shunt trip activates Bell Alarm with Lockout
5	Disabled	UVR trip activates Bell Alarm with Lockout
6	Enabled	Protection trip activates Bell Alarm with Lockout

Table 14. Accessory configuration switch settings, including the factory defaults.

Description of Switch Settings

Following are descriptions of the effects of each accessory switch when it is *enabled*:

1. When a Shunt Trip accessory causes the breaker to trip, the contacts of the Bell Alarm–Alarm Only also change state. The factory switch setting is *disabled*.

2. When an Undervoltage Release accessory causes the breaker to trip, the contacts of the Bell Alarm–Alarm Only also change state. The factory switch setting is *disabled*.
3. When the protection trip (long-time, short-time, instantaneous, or protective-relay) occurs, the contacts of the Bell Alarm–Alarm Only also change state. The factory switch setting is *enabled*.
4. When the Shunt Trip accessory causes the breaker to trip, the contacts of the Bell Alarm with Lockout also change state. The factory switch setting is *disabled*.
5. When the Undervoltage Release accessory causes the breaker to trip, the contacts of the Bell Alarm with Lockout also change state. The factory switch setting is *disabled*.
6. When a protection trip (long-time, short-time, instantaneous, or protective-relay) occurs, the contacts of the Bell Alarm with Lockout also change state. The factory switch setting is *enabled*.

3-9 Motor Operator Mechanism

The Motor Operator Mechanism, shown in Figure 19, provides a means of remotely or automatically charging the springs that close the breaker. Table 15 lists the catalog numbers for the available Motor Operator Mechanism models. For installation instructions see GEH-6281.

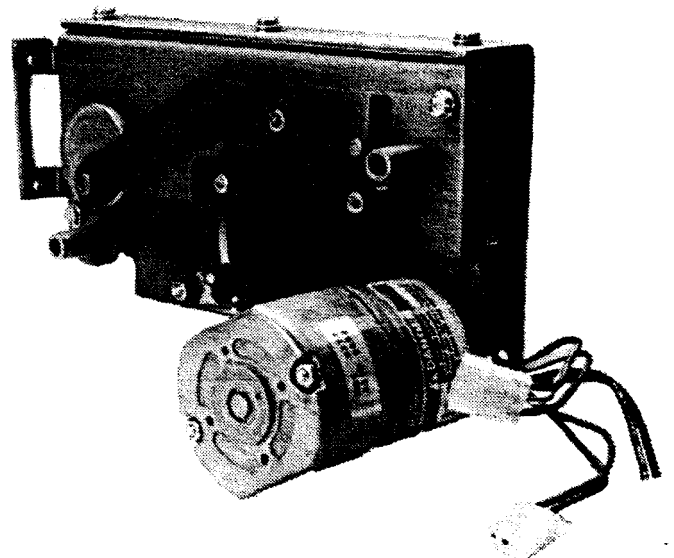

Figure 19. Motor Operator Mechanism.

Power Break® II Circuit Breakers

Chapter 3. Accessory Operation

Catalog No.	Voltage Rating
SPE024	24 Vdc
SPE048	48 Vdc
SPE072	72 Vdc
SPE120	120 Vac
SPE125	125 Vdc
SPE240	240 Vac

Table 15. Catalog numbers and operating voltages for the Motor Operator Mechanism.

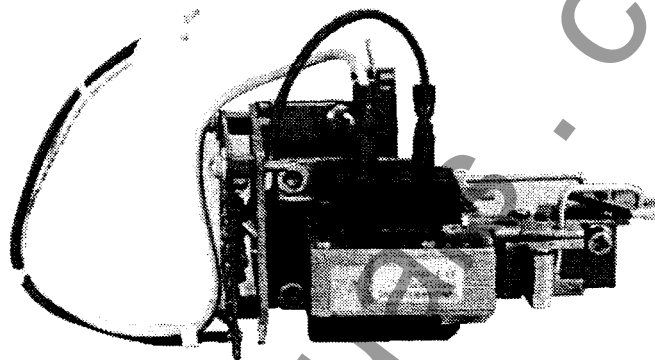

Figure 20. Remote Close accessory.

Remote Operation

The circuit breaker closing springs can be charged remotely by shorting terminals 17 and 35 on the terminal block on the right side of the breaker, with a push button or similar device, for a minimum of five seconds.

Automatic Operation

Connect terminals 17 and 35 on the terminal block on the right side of the breaker with a jumper wire. The Motor Operator will automatically recharge the breaker closing springs whenever the breaker closes.

CAUTION: Do not wire breakers for both automatic charge and automatic close.

ATTENTION: Ne pas câbler les disjoncteurs pour tous les deux l'armement automatique et la fermeture automatique.

Catalog No.	Voltage Rating
SPRCS024	24 Vdc
SPRCS048	48 Vdc
SPRCS072	72 Vdc
SPRCS120	120 Vac
SPRCS125	125 Vdc
SPRCS240	240 Vac

Table 16. Catalog numbers and operating voltages for the Remote Close accessory.

3-11 Key Interlock Mounting Provision

The Key Interlock Mounting Provision provides mounting for one to four key locks. The GE catalog number is SPK4.

The key locks must have a zero extension when the bolt is withdrawn with 0.75-inch extension when the bolt is extended. The lock may be up to 1.50 inch wide. Catalog numbers for suitable locks from ABB-Kirk® and Superior Interlock are listed in Table 17. For installation instructions see GEH-6279.

# Locks	ABB-Kirk® Cat. No.	Superior Cat. No.	Approx. Lock Length
1	KFN00001_①	S105827Y	2.38"
2	KFN00002_①	S105828Y	3.38"
3	KFN00003_①	S105829Y	4.38"
4	KFN00004_①	S105827-4Y	5.48"

① Final digit may be 0, 1, 2, or 3 depending on key removable positions.

Table 17. Catalog numbers of Key Interlock models.

3-10 Remote Close

The Remote Close accessory, shown in Figure 20, provides a means of remotely closing the circuit breaker after the springs have been charged. Table 16 lists the catalog numbers for the available models. For installation instructions see GEH-6283.

Remote Operation

The circuit breaker can be closed remotely, provided that the springs are charged, by applying the rated voltage to terminals 16 and 34 on the terminal block on the right side of the breaker.

The Remote Close accessory is continuously rated and has an anti-pump feature that prevents a motor-operated breaker from repeatedly closing into a fault. Closing control voltage must be removed and reapplied for each breaker closure.

Operation

The Key Interlock prevents the breaker from closing by holding the padlock tab extended, thus keeping the trip latch in the tripped position. A secondary padlock lever is included with the Key Interlock, since the Key Interlock blocks easy access to the standard padlock hasp. To operate, use the following procedure:

1. Trip the breaker (press the OFF button).
2. Grasp the padlock tab and pull it out, as illustrated in Figure 21. Note that if the breaker contacts are closed, the padlock tab will not pull out.
3. Turn the key, securing the padlock tab in the extended position. The breaker cannot be closed until the Key Interlock is disengaged.
4. Rotate the secondary padlock lever out and assemble padlocks as desired.

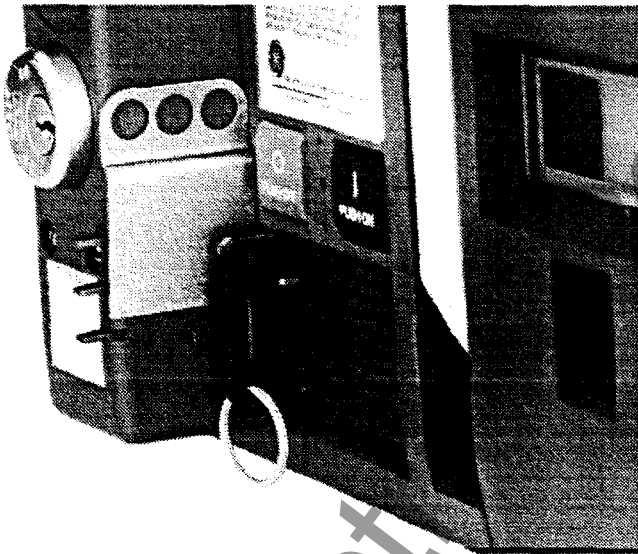

Figure 21. Side view of the breaker, showing the padlock tab extended with the Key Interlock installed.

CAUTION: Repeated attempts to close a locked-out circuit breaker will damage the breaker mechanism.

ATTENTION: Les tentatives à maintes fermer un disjoncteur verrouillé en position "ouvert" endommageront le mécanisme de disjoncteur.

3-12 Mechanical Counter

The Mechanical Counter, shown in Figure 22, counts the number of times the breaker is closed. The catalog number of the Mechanical Counter is SPCOUNTER. For installation instructions see GEH-6280.

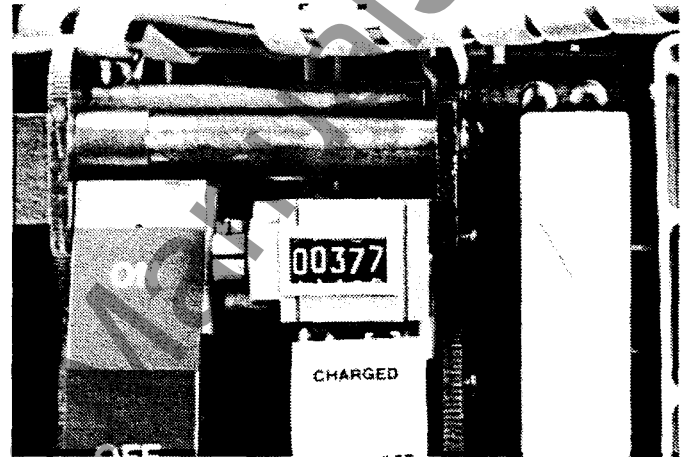

Figure 22. Mechanical Counter.

3-13 Auxiliary Switch Module

The Auxiliary Switch Module, shown in Figure 23, provides remote indication of the breaker main contact position through the terminals on the terminal block on the left side of the breaker.

Auxiliary Switch Modules are available with 4, 8, and 12 switches with ratings of 6 A at 240 Vac or 600 Vac. Additional ratings of 0.5 A at 125 Vdc and 0.25 A at 250 Vdc apply to all models. Catalog numbers are listed in Table 18. For installation instructions see GEH-6274.

Operation

Each auxiliary switch provides two outputs that can be used to indicate breaker main contact position. The A output is open or closed the same as the breaker, while the B output is the opposite to the breaker contacts. Figure 24 is a wiring diagram of each auxiliary switch.

The connections for the auxiliary switch outputs are found on the terminal block on the left side of the breaker and are listed in Table 19.

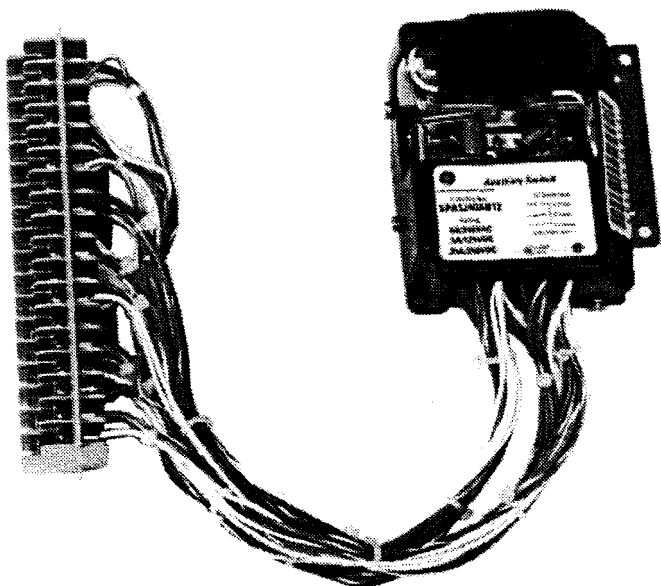

Figure 23. Auxiliary Switch Module with 12 switches.

# Switches	240 Vac	600 Vac [Ⓢ]
4	SPAS240AB4	SPAS600AB4
8	SPAS240AB8	SPAS600AB8
12	SPAS240AB12	SPAS600AB12

[Ⓢ] 600 Vac devices are not UL listed.

Table 18. Auxiliary Switch Module catalog numbers.

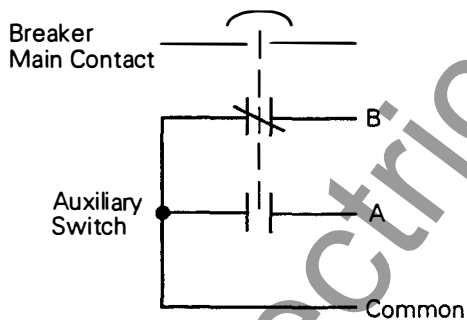

Figure 24. Auxiliary switch wiring diagram.

Terminal (upper)		Terminal (lower)	
1	Auxiliary 12 A	19	Auxiliary 11 A
2	Auxiliary 12 B	20	Auxiliary 11 B
3	Auxiliary 12 common	21	Auxiliary 11 common
4	Auxiliary 10 A	22	Auxiliary 9 A
5	Auxiliary 10 B	23	Auxiliary 9 B
6	Auxiliary 10 common	24	Auxiliary 9 common
7	Auxiliary 8 A	25	Auxiliary 7 A
8	Auxiliary 8 B	26	Auxiliary 7 B
9	Auxiliary 8 common	27	Auxiliary 7 common
10	Auxiliary 6 A	28	Auxiliary 5 A
11	Auxiliary 6 B	29	Auxiliary 5 B
12	Auxiliary 6 common	30	Auxiliary 5 common
13	Auxiliary 4 A	31	Auxiliary 3 A
14	Auxiliary 4 B	32	Auxiliary 3 B
15	Auxiliary 4 common	33	Auxiliary 3 common
16	Auxiliary 2 A	34	Auxiliary 1 A
17	Auxiliary 2 B	35	Auxiliary 1 B
18	Auxiliary 2 common	36	Auxiliary 1 common

Table 19. Auxiliary switch positions on the terminal board on the left side of the breaker, Block A.

3-14 Door Interlock

The Door Interlock, shown in Figure 25, prevents the casual opening of the enclosure door, particularly while the breaker is ON. The catalog number of the Door Interlock is SPDIL. For installation instructions see GEH-6276.

Operation

The Door Interlock prevents the opening of the enclosure door unless the locking lever is disengaged. The lever can be disengaged easily with the breaker OFF or with somewhat greater difficulty with the breaker ON, as described below.

Opening Door with Breaker Off

To open the enclosure door when the breaker is OFF, pull up on the padlock tab and slide the Door Interlock lever counter-clockwise until it no longer obstructs the door. When the door is reclosed, simply slide the lever back into the locking position.

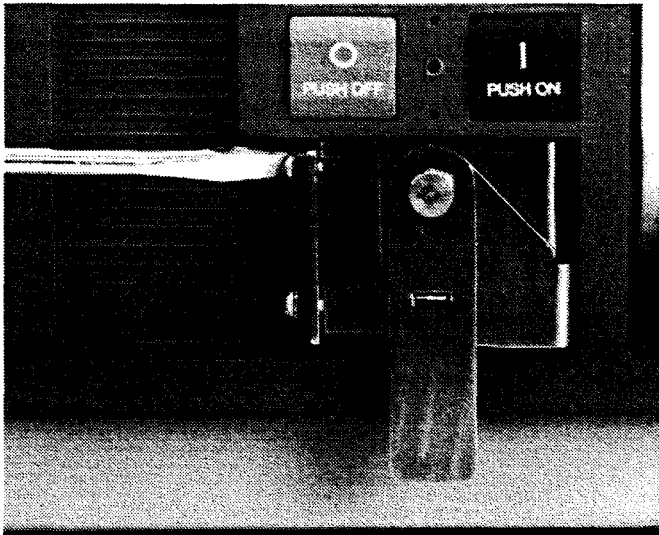

Figure 25. Door Interlock accessory installed on the breaker.

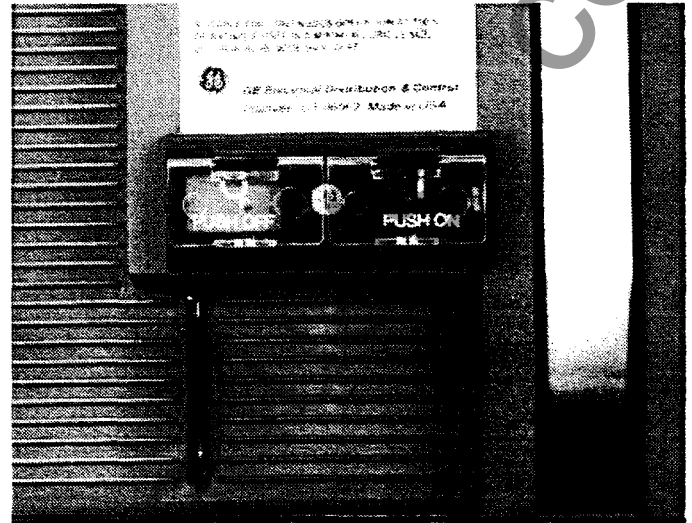

Figure 26. Push Button Cover.

Opening Door with Breaker On

The Door Interlock can be defeated, to allow opening the enclosure door with the breaker ON, even though the padlock tab cannot be lifted. Depress the interlock spring with a screwdriver in the slot on the top of the locking lever and push the lever counter-clockwise to disengage it from the spring. Remove the screwdriver, then continue rotating the locking lever until it clears the door.

3-15 Push Button Cover

The Push Button Cover, shown in Figure 26, prevents accidental or unauthorized closing or opening of the circuit breaker with the local push buttons. It consists of two unbreakable, individually sealable Lexan® shields, one over the PUSH ON button and one over the PUSH OFF button. The catalog number is SPPBCOVER. For installation instructions see GEH-6282.

Operation

Close the cover and put a sealing wire or wire tie in the slot. Each of the covers may be sealed independently.

Power Break® II Circuit Breakers

Chapter 4– Trouble-Shooting Guide

The following guide is provided for trouble-shooting and isolating common problems. It does not cover every possible situation. Contact the ED&C Customer Support Center at 800-843-3742 if any problem is not resolved by these procedures.

Symptom	Possible Cause	Corrective Action
1. The breaker does not close when the ON button is pressed and there is no sound of the closing spring releasing.	The closing spring is not fully charged.	On a manually operated breaker, operate the handle until the indicator shows CHARGED. On an electrically operated breaker, check that the voltage to the motor operator is at least 85% of nominal. See GEH-6281, <i>Motor Operator Mechanism</i> .
	The Bell Alarm with Lockout is deployed.	Correct the condition that initiated the bell alarm, then depress the yellow plunger on the Bell Alarm with Lockout module to reset the lockout. See GEH-6278, <i>Bell Alarm with Lockout</i> .
	The Undervoltage Release is not energized. The Trip Unit is not properly installed.	See GEH-6285, <i>Undervoltage Release</i> , for details on energizing the UVR. See GEH-6273, <i>MicroVersaTrip Plus™ and MicroVersaTrip PM™ Trip Units</i> , or DEH-049, <i>Power+™ Trip Units</i> , for the Trip Unit installation procedure.
2. The breaker does not close when the ON button is pressed, but the closing spring is heard to release.	The Trip Unit detected a fault and immediately tripped the breaker.	Clear the fault, then recharge the closing spring and close the breaker. For fault diagnostics, see GEH-6273, <i>MicroVersaTrip Plus™ and MicroVersaTrip PM™ Trip Units</i> , or DEH-049, <i>Power+™ Trip Units</i> .
	The Shunt Trip is energized.	See GEH-6284, <i>Shunt Trip</i> , for instructions on de-energizing the unit.
	The breaker is locked in the OFF position by a padlock or key interlock.	After ensuring that the safety reason for locking the breaker no longer applies, remove the padlock or key interlock. See GEH-6279, <i>Key Interlock Mounting Provision</i> .
	The breaker is interlocked with another breaker with a walking beam. If a draw-out breaker, it is not fully inserted in the substructure (between the TEST and CONNECTED positions).	See GEH-6286, <i>Walking-Beam Interlock</i> , for the removal procedure. Ensure that the breaker is fully racked in to the substructure. See GEH-6272, <i>Draw-Out Substructure, 800-4000 Amperes</i> .
3. The breaker can be opened locally, but not remotely.	There is a problem with the Shunt Trip.	See the trouble-shooting instructions in GEH-6284, <i>Shunt Trip</i> .
	There is a problem with the Undervoltage Release.	See the trouble-shooting instructions in GEH-6285, <i>Undervoltage Release</i> .

For any other problems related to Power Break II accessories, consult the corresponding User's Guide:

- GEH-6271, *Draw-Out 800-4000 Ampere Frames*
- GEH-6272, *Draw-Out Substructure, 800-4000 Ampere*
- GEH-6273, *MicroVersaTrip Plus™ and MicroVersaTrip PM™ Trip Units*
- GEH-6274, *Auxiliary Switch Module*
- GEH-6275, *Bell Alarm – Alarm Only*
- GEH-6276, *Door Interlock*
- GEH-4546, *Lugs & Adapters for 800-2000 A Frames*
- GEH-6278, *Bell Alarm with Lockout*
- GEH-6279, *Key Interlock Mounting Provision*
- GEH-6280, *Mechanical Counter*
- GEH-6281, *Motor Operator Mechanism*
- GEH-6282, *Push Button Cover*
- GEH-6283, *Remote Close*
- GEH-6284, *Shunt Trip and Shunt Trip with Lockout (except 480 and 600 Vac)*
- GEH-6519, *Shunt Trip and Shunt Trip with Lockout, 480 & 600 Vac*
- GEH-6285, *Undervoltage Release (except 480 and 600 Vac)*
- GEH-6520, *Undervoltage Release, 480 & 600 Vac*
- GEH-6286, *Mechanical Interlock*
- GEH-6440, *Draw-Out Substructure Rail Kit*
- GEH-6460, *Secondary Disconnect*
- DEH-049, *Power+™ Trip Units*



GE Electrical Distribution & Control

General Electric Company
41 Woodford Ave., Plainville, CT 06062

GEH-6270C 0697

© 1997 General Electric Company