



INSTRUCTIONS

GEK-39672F

SUPERSEDES GEK-39672E

**POWER/VAC* METAL-CLAD SWITCHGEAR
TYPES 4.16 AND 13.8**

**FOR POWER-VAC CIRCUIT BREAKER
TYPES VB-4.16, VB-7.2, VB-13.8, VB1-4.16, AND VB1-13.8**

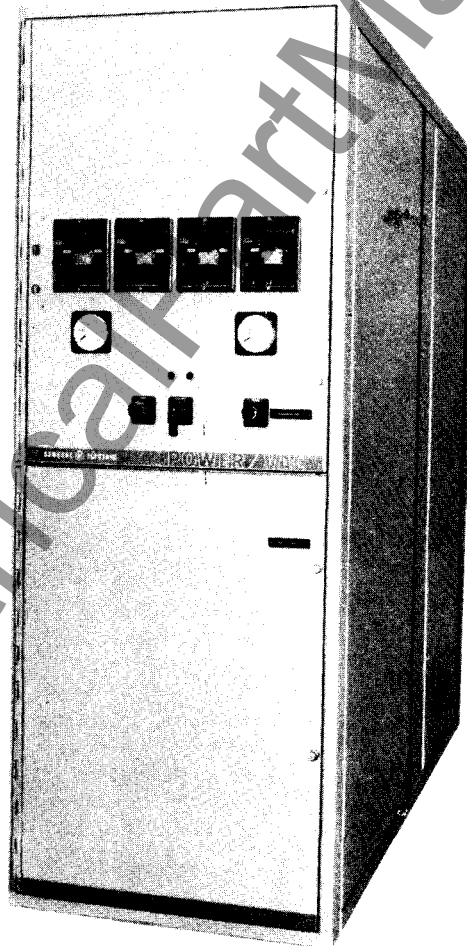

GENERAL  ELECTRIC

CONTENTS

	Page
Introduction	5
Safety	5
General	5
Specific	7
Receiving, Handling & Storage	7
Receiving	7
Handling	9
Storage of Indoor Equipment	9
Storage of Outdoor Equipment	10
Description	17
Secondary Enclosure	17
Primary Enclosure	17
Breaker Removable Element	17
Breaker Lift Truck	17
Breaker Racking Mechanism	18
Remote Racking Operator	18
Primary Disconnects	18
Bus Compartment	19
Current Transformer Compartment	19
Primary Termination Space	19
Voltage Transformers	19
Current-Limiting Fuses and Control Power Transformer	19
Dummy Removable Element	20
Ground and Test Device	20
Installation	21
Location	21
Anchoring	21
Indoor Equipment — Floor Preparation	21
Outdoor Equipment	21
Outdoor Equipment With Protected Aisle	25
Outdoor Equipment With Common Aisle	25
Breaker Removable Element	26
Test Cabinet	26
Addition of Units to Existing Equipment	26
Connections	28
Main Bus Assembly	28
Taped Insulation Instructions for 5 & 15kV Equipment	29
Bus Duct	32
Primary Cables	32
Insulating Primary Cable Terminations	33
Potheads	34
Termination Without Pothead	34
Ground Fault Current Transformers (Through-Type)	34
Control Cables	35
Ground Bus	35
Lightning Protection	35
Surge Suppressors	35
Roof Entrance Bushing	35

Testing and Inspection	35
Operation	36
Breaker Installation	36
Breaker Racking with Front Door Closed	39
Remote Racking Attachment	39
Positive Interlock	39
Negative Interlock	39
Spring Discharge Interlock	40
Interference Interlock	41
Closing Spring Gag Interlock	42
Key Lock	42
Padlocks	42
Stationary Auxiliary Switch	42
Breaker Position Switch	42
Space Heaters	42
Maintenance	43
Recommended Maintenance	44
Indoor and Outdoor Acrylic Paint Finish	44
Renewal Parts	45

www.ElectricalPartManuals.com

LIST OF ILLUSTRATIONS

Figure		Page
1	Typical Indoor Power/ Vac* Metal-clad Switchgear Equipment	6
2	Typical Outdoor Power/ Vac* Metal-clad Switchgear Equipment	6
3	Typical Outdoor Power/ Vac* Metal-clad Switchgear Equipment with Protected Aisle	7
5	Installation Details for Indoor Power/ Vac* Metal-clad Switchgear	8,9
6	Installation Details for Outdoor Power/ Vac* Metal-clad Switchgear	10,11
7	Installation Details for Outdoor Power/ Vac* Metal-clad Switchgear with Protected Aisle	12, 13
8	Installation Details for Outdoor Power/ Vac* Metal-clad Switchgear with Aisle Extension	14, 15
9	Side Section View Power/ Vac* Metal-clad Switchgear	16
10	Power/ Vac* Breaker and Lift Truck	16
11	Remote Racking Operator	17
12	Primary Disconnects 1200, 2000, 3000 Amp	18
14	Voltage Transformer Drawout Carriage	19
15	Control Power Transformer Drawout Carriage	19
16	Metal-clad Equipment Detail Views	22, 23, 24
17	Test Cabinet	26
18a	Outdoor Metal-clad Switchgear Addition of Units to a Line-up	27
18b	Outdoor Metal-clad Switchgear with Protected Common Aisle — Addition of Units to Line-up	27
19	Bolt Torque Values for Power/ Vac* Switchgear	28
20	Typical Shipping Splits	28
21	Bus Compartment Cover	29
22	Bus Insulating Boot	29
23	Bus Bars	30
24	Bus Connection Joint	30
25	Dead End Bus Joint	30
26	Current Transformer Joint	30
27	Tee Connection Joint	31
28	Double Bus Bar Joint	31
29	Pothead or Bushing or Terminator	31
30	#6 Cable Termination Joint	31
31	Insulation Materials for Field Installation — 5kV & 15kV	32
32	Bus Duct Gasket	32
33	Installation of Primary Cables	33
34	Cable Termination Without Pothead, Single Conductor	33
35	Rear View of Unit Showing Through - Type Ground Fault Current Transformers	34
36	Control Cable Guide	36
37	Racking Mechanism	37
38	Lift Truck Connection to Rails	37
39	Racking Arm Position Indicator Lever	38
40	Positive Interlock	40
41	Negative Interlock	41
42	Key Lock and Padlocks	41
43	Closing Spring Discharge Interlock	42
44	Interference Interlock	42
45	Stationary Auxiliary Switch and Breaker Position Switch	43
46	Right Hand Track Assembly for Vacuum Metal-clad	45
47	Left Hand Track Assembly for Vacuum Metal-clad	46
48	Spreader Bar, Chain and Idler Sprocket for Vacuum Metal-clad	46
49	Connection Boots for Primary Disconnect, Surge Suppressors, and Bus	47
50	4.16kV Inter Unit Barrier	47
51	13.8kV Inter Unit Barrier	48
52	4.16kV Primary Disconnect	48
53	13.8kV Primary Disconnect	48
54	Vacuum Metal-clad Breaker Unit	49

**POWER/VAC* METAL-CLAD SWITCHGEAR
TYPES 4.16 AND 13.8**

**FOR POWER-VAC CIRCUIT BREAKER
TYPES VB-4.16, VB-7.2, VB-13.8, VB1-4.16, and VB1-13.8**

INTRODUCTION

Metal-clad switchgear is equipment designed for the protection, instrumentation and control of various types of electrical apparatus and power circuits.

The switchgear consists of one or more vertical sections which are mounted side by side and connected mechanically and electrically to form a complete switching equipment. Typical pieces of equipment are shown in Figs. 1, 2 and 3.

The circuit breakers are easily removable to provide maximum accessibility for maintenance with minimum interruption of services. The switchgear is designed to provide a high degree of safety to the operator. All equipment is enclosed in grounded metal compartments.

The equipment is available in the ratings listed in the following table. The ratings of the equipment and devices are based on usual service conditions as covered in ANSI standards. Operation at currents above the equipment rating will result in temperature rises in excess of these standards, and is not recommended. For outdoor installation the same basic equipment is built into a weatherproof housing as in Figs. 2, 3

and 4. The equipment is not designed for exposure to dripping liquids as this condition is not a usual ANSI service condition. Dripping liquids can destroy the integrity of the insulation system and must be avoided.

TYPE EQUIPMENT	CIRCUIT BREAKER	MAXIMUM VOLTAGE KV	CONTINUOUS CURRENT AMPERES	NOMINAL INTERRUPTING CAPACITY MVA
VM-4.16	VB-4.16-250	4.76	1200-2000	250
VM-4.16	VB-4.16-350	4.76	1200-2000 3000	350
VM-13.8	VB-7.2-500	8.25	1200-2000	500
VM-13.8	VB-13.8-500	15.0	1200-2000	500
VM-13.8	VB-13.8-750	15.0	1200-2000	750
VM-13.8	VB-13.8-1000	15.0	1200-2000 3000	1000
FOR VB-1 SERIES SEE GEK 86132A				

SAFETY

Each user is responsible for communicating all safety instructions and practices to personnel associated with this equipment.

The following practices should be included in a user's safety program. These do not supplant the user's responsibility for devising a complete safety program. They are rather suggestions concerning some aspects of personnel safety related to circuit breakers and metalclad switchgear equipment. General Electric assumes no responsibility for user practices which deviate from these recommendations.

Although the interlock linkage has been designed to be rugged, inadvertent bending of the spring discharge and/or negative interlock actuating linkages during breaker storage, lift truck or stack insertion operations could negate their proper functioning and therefore create a safety risk. This type of handling damage must be avoided by any user.

These instructions do not purport to cover all details or variations in equipment nor to provide for every possible contingency to be met in connection with installation, operation or maintenance. Should further information be desired or should particular problems arise which are not covered sufficiently for the purchaser's purposes, the matter should be referred to the General Electric Company.

To the extent required the products described herein meet applicable ANSI, IEEE and NEMA standards; but no such assurance is given with respect to local codes and ordinances because they vary greatly.

*Registered Trademark of the General Electric Company

All servicing of switchgear must be performed only by trained personnel, with **BOTH THE PRIMARY AND CONTROL POWER CIRCUITS DE-ENERGIZED.**

GENERAL

1. The term "metalclad switchgear" includes circuit breakers, associated interrupting, switching control, metering and protective devices, together with their supporting metal structures, enclosures, electrical connections and accessories.
2. All personnel associated with installation, operation and maintenance of metalclad switchgear should be thoroughly instructed and supervised regarding power equipment in general as well as the particular model of equipment with which they are working. Instruction books should be closely studied and followed.

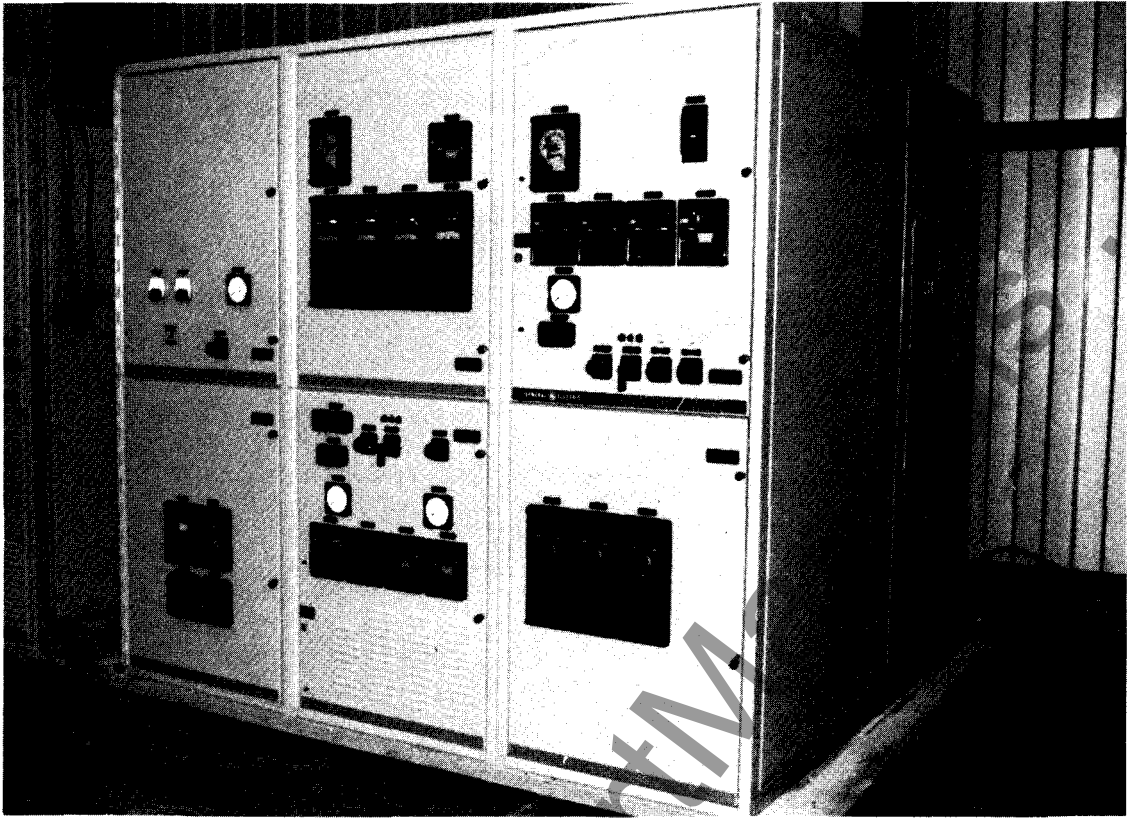

Fig. 1 Typical Indoor Power/Vac* Metal-Clad Switchgear Equipment

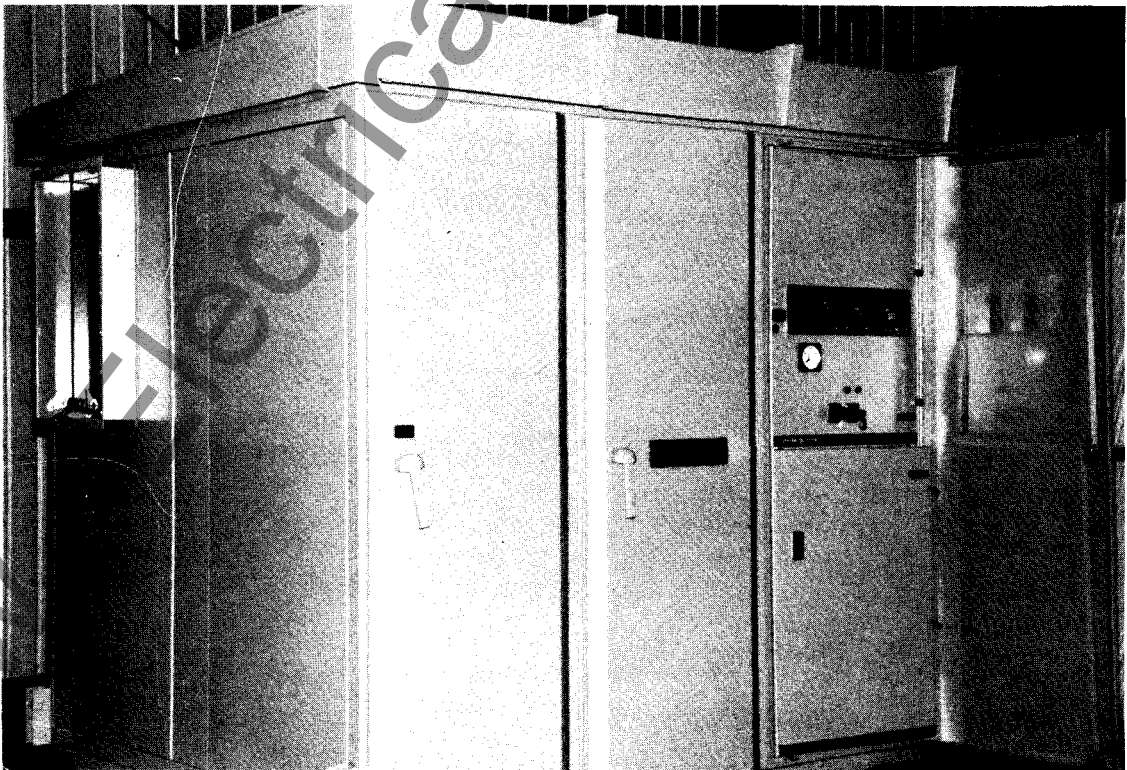

Fig. 2 Typical Outdoor Power/Vac* Metal-Clad Switchgear Equipment

Fig. 1 (8918455D)

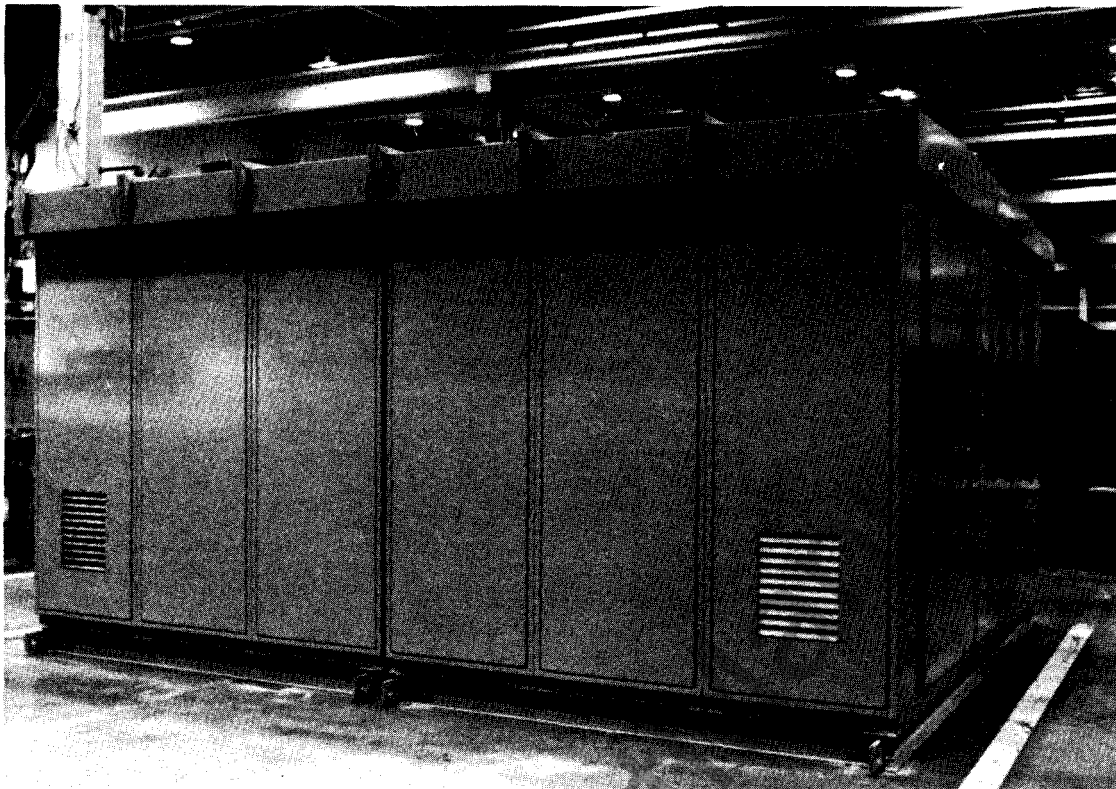

Fig. 3 Typical Outdoor Power/Vac* Metal-Clad Switchgear with Protected Aisle

3. Maintenance programs must be well planned and carried out in a manner consistent with both customer experience and manufacturer's recommendations. Good maintenance is essential to electrical equipment reliability and safety.

SPECIFIC

1. DO NOT work on any energized breaker. If work has to be performed on the breaker, rack it out and de-energize the spring-charged mechanism. Once the breaker has been de-energized, all control power must be disconnected before servicing.
2. All spring-charged mechanisms related to a breaker must be serviced only by skilled and knowledgeable personnel capable of releasing each spring load in a

controlled manner. Particular care must be exercised to keep personnel clear of mechanisms which are to be operated or released. Information on construction of such mechanisms is provided in the instruction book for the particular breaker.

3. DO NOT approach or service any equipment which is normally energized by any switchgear unless the breaker is in the disconnect/test position. In this disconnect/test position the load bus must be adequately grounded and the breaker secured.
4. If there is any evidence of or suspected deterioration of breaker dielectric capability, adjacent areas should be promptly cleared of personnel. The breaker should then be de-energized by "back-ups" and isolated.

RECEIVING, HANDLING AND STORAGE

RECEIVING

Every case or crate leaving the factory is plainly marked at convenient places with case number, requisition number, customer's order, front or rear, and, when for size and other reasons it is necessary to divide the equipment for shipment, with the section numbers of the portion of equipment enclosed in each shipping case.

The contents of each package of the shipment are listed in the Packing Details. This list is forwarded with the shipment, packed in one of the cases. The case is especially marked and its number can also be obtained from the Mem-

orandum of Shipment. To avoid the loss of small parts when unpacking, the contents of each case should be carefully checked against the Packing Details before discarding the packing material. Notify the nearest General Electric Company representative at once if any shortage of material is discovered.

Before leaving the factory all elements are carefully inspected and packed by workmen experienced in the proper handling and packing of electrical equipment. Upon receipt of any apparatus an immediate inspection should be

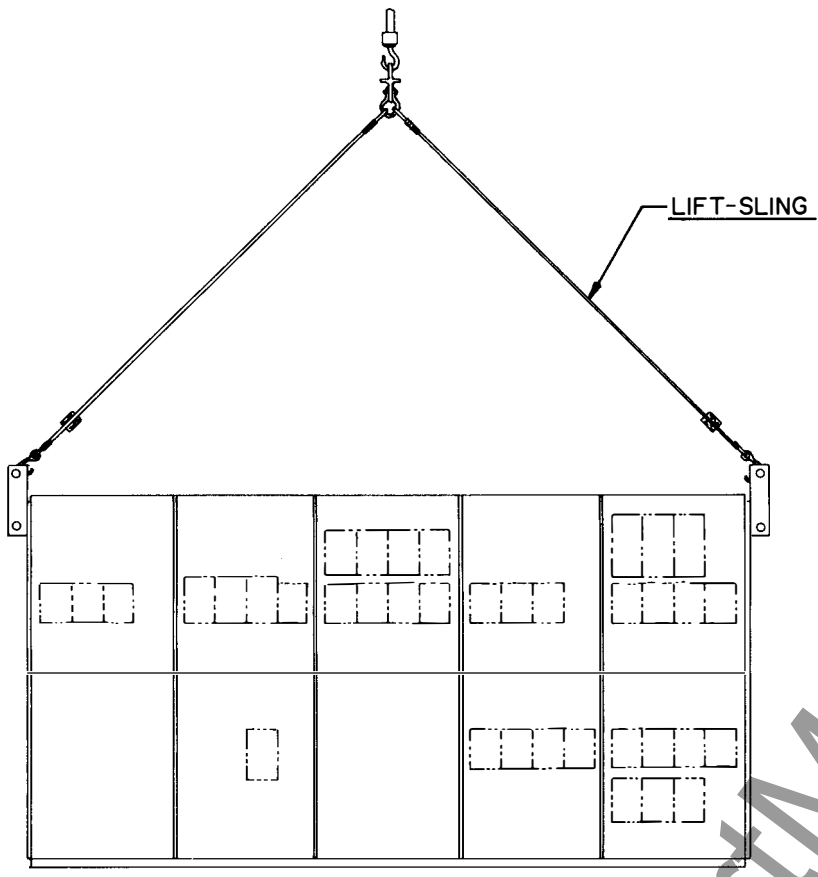

FRONT VIEW

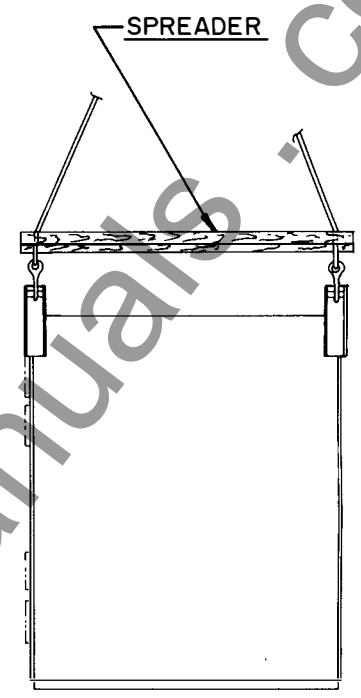

SIDE VIEW

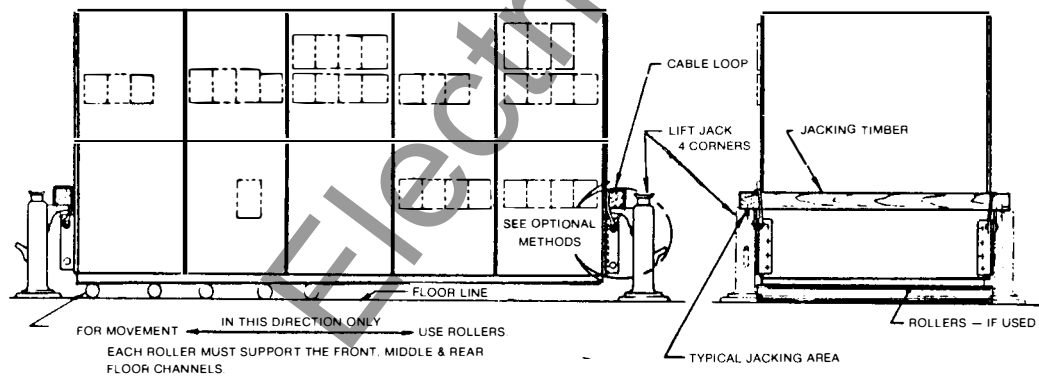

LIFT JACKING METHOD

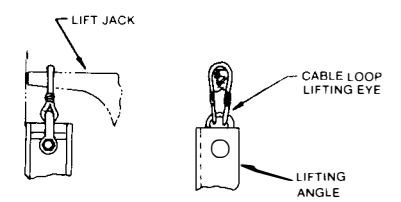

OPTIONAL METHOD -AB-

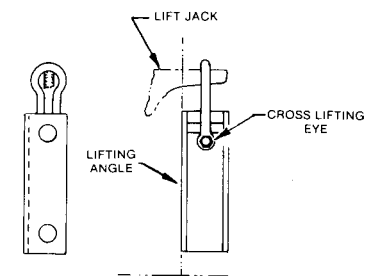

OPTIONAL METHOD -AA-

Fig. 5 Installation Details for Indoor Power/ Vac* Metal-Clad Switchgear

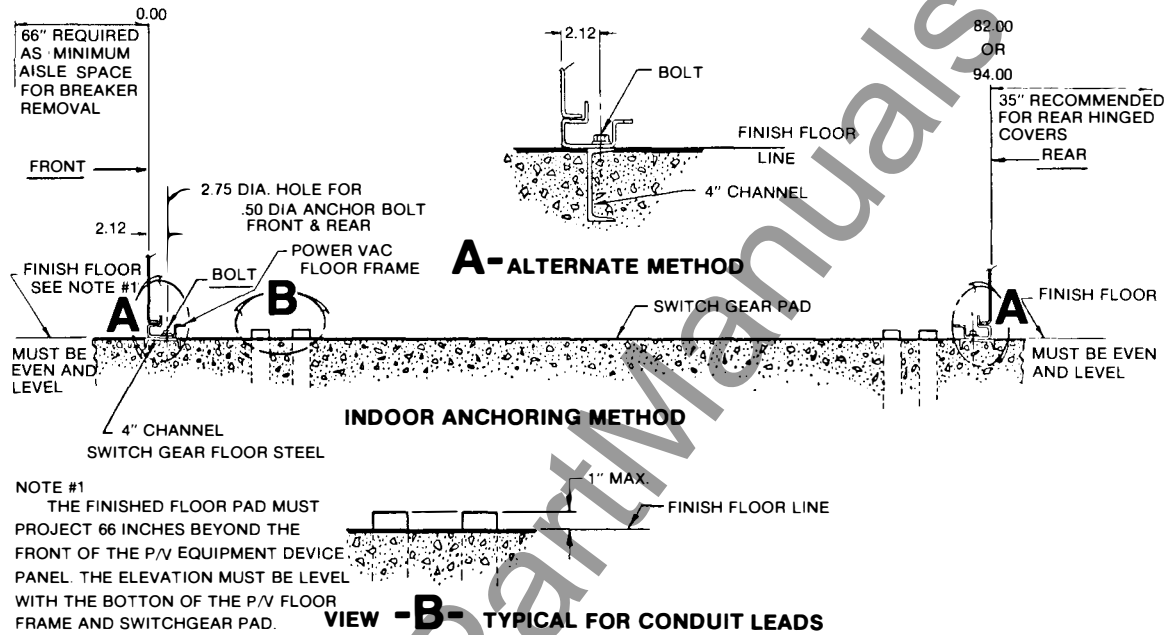

Fig. 5 Installation Details for Indoor Power/Vac* Metal-Clad Switchgear (Continued)

made for any damage sustained while enroute. If damage is evident or an indication of rough handling is visible, a claim for damage should be filed at once with the transportation company and the General Electric Company notified promptly. Information as to damaged parts, part number, case number, requisition number, etc., should accompany the claim.

HANDLING

Before uncrating, indoor equipment may be moved by crane with slings under the skids. Spreaders should be used to keep the cables from rubbing against the equipment. If crane facilities are unavailable, rollers under the skids may be used. Fig. 5 shows the suggested method of anchoring the switchgear after it is removed from the skids. After the equipment is in place, the lifting brackets should be removed.

Methods of handling outdoor equipment are shown in Figs. 6, 7 and 8. After the equipment is in place, the lifting brackets should be removed.

STORAGE OF INDOOR EQUIPMENT

If it is necessary to store the equipment for any length of time, the following precautions should be taken to prevent breakage, corrosion, damage or deterioration:

1. Uncrate the equipment. Check it thoroughly for damage.
2. Cover important parts such as jack screws, gears and chain of racking mechanism, linkage and moving parts with a heavy oil or grease, such as 0282A2048 P009 which is supplied with the gear.
3. Store in a clean, dry place with a moderate temperature (such as 40-100°F) and cover with a suitable cover to prevent deposits of dirt or other foreign substances upon movable parts and electrical contact surfaces.
4. Batteries should be uncrated and put on trickle charge immediately upon receipt.

- If dampness or condensation is encountered in the storage location, (can occur with rapid temperature changes) heaters should be placed inside the equipment to prevent moisture damage. Approximately 300 watts of heat per vertical stack will be required. The suggested arrangement is one 75-watt heat element in each breaker and primary cable compartment. Remove all cartons and other miscellaneous materials packed inside units before energizing any heaters. If the equipment has been subjected to moisture, it should be carefully dried out using forced warm air and then tested with a 1000 or 2500 volt megger. A reading of at least 200 megohms should be obtained.
- Breakers should be prepared for storage separately. Refer to the breaker instruction book GEK-39671 for details.

STORAGE OF OUTDOOR EQUIPMENT

- Uncrate the equipment. Check it thoroughly for damage.

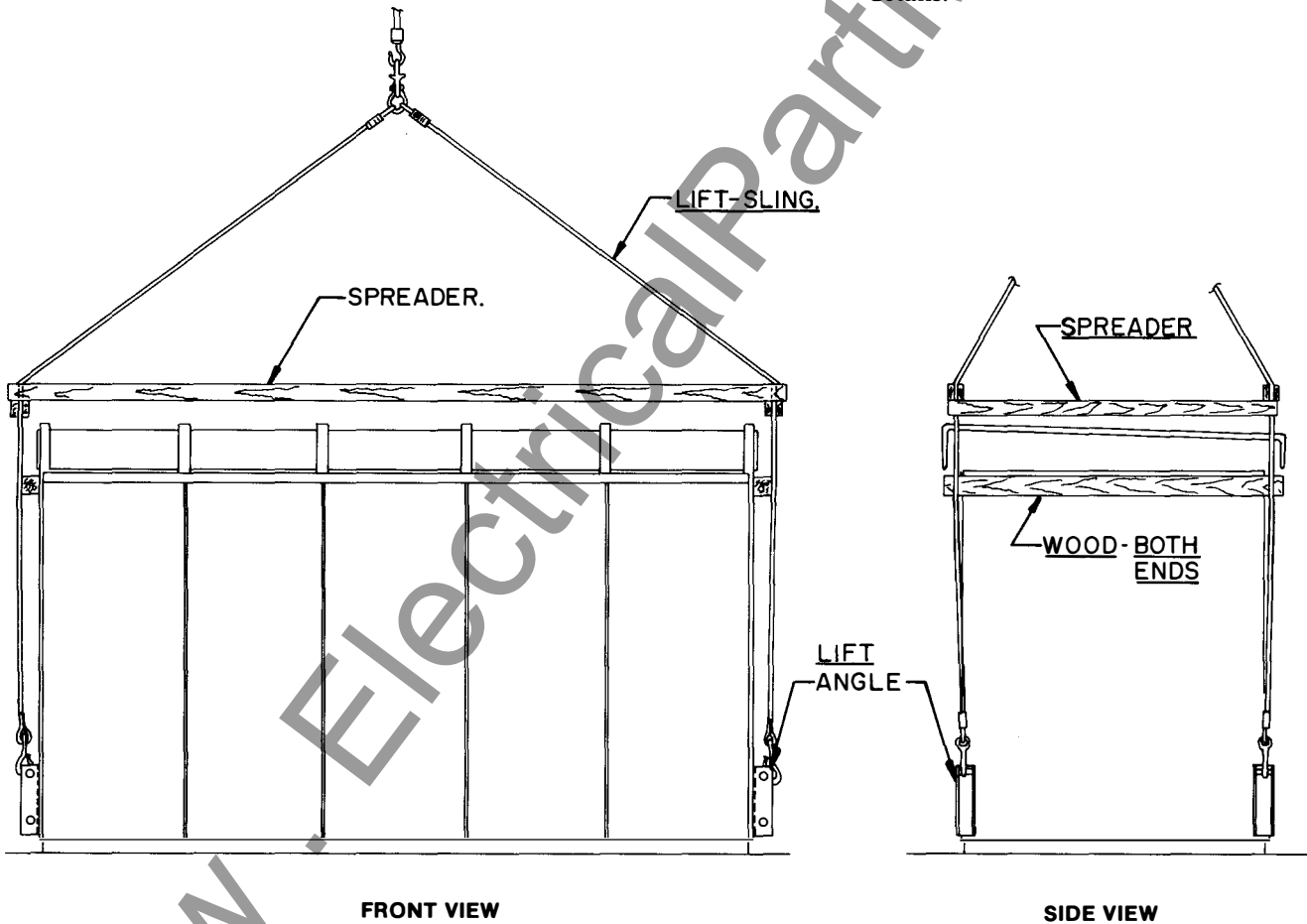

Fig. 6 Installation Details for Outdoor Power/Vac* Metal-Clad Switchgear

- Cover important parts such as jack screws, gears and chain of racking mechanism, linkage and moving machine-finished parts with a heavy oil or grease such as 0282A2048P009 supplied.
- Batteries should be uncrated and put on trickle charge immediately upon receipt.
- Dampness or condensation can be prevented by making a temporary power supply connection to the heaters already installed in the equipment. If the equipment has been subjected to moisture it should be dried out in the same manner as described for indoor equipment.

CAUTION: BE SURE THAT FUSES TO CPT SECONDARY HAVE BEEN REMOVED BEFORE ENERGIZING THE TEMPORARY CONNECTION TO THE HEATERS. THIS IS TO PREVENT A BACK FEED OF HIGH VOLTAGE AT CPT PRIMARY.

- Breakers should be prepared for storage separately. Refer to the breaker instruction book GEK-39671 for details.

Fig. 9 (0209B4646 Rev. 0)

Fig. 6 (0209B4647 Rev. 0)

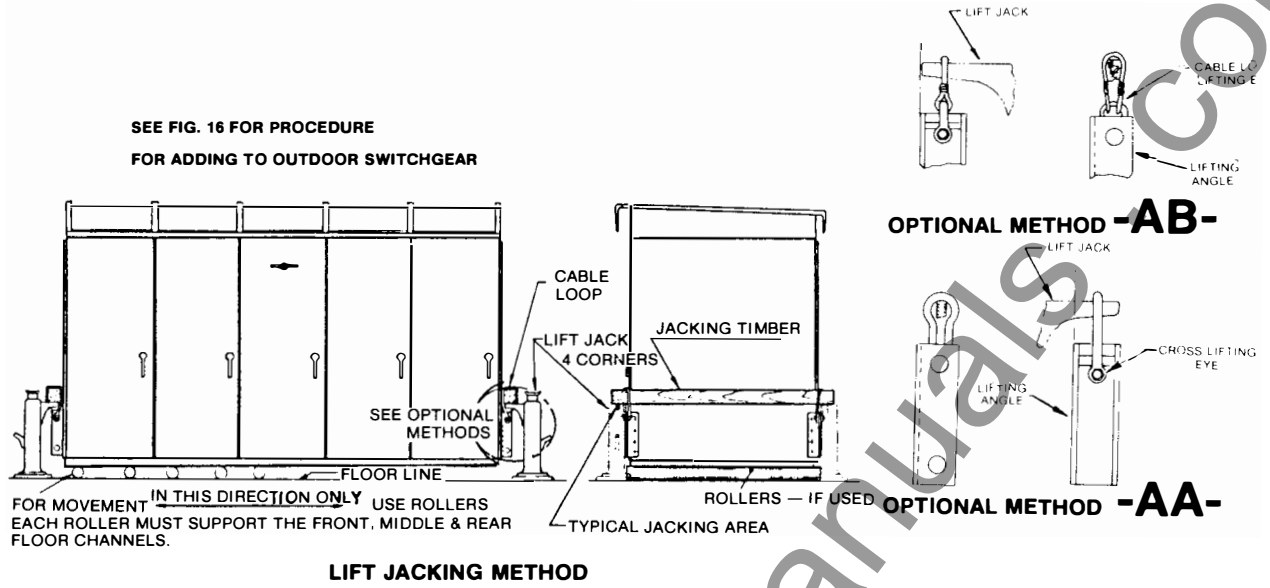

Fig. 6 (0209B4644 Rev. 4)

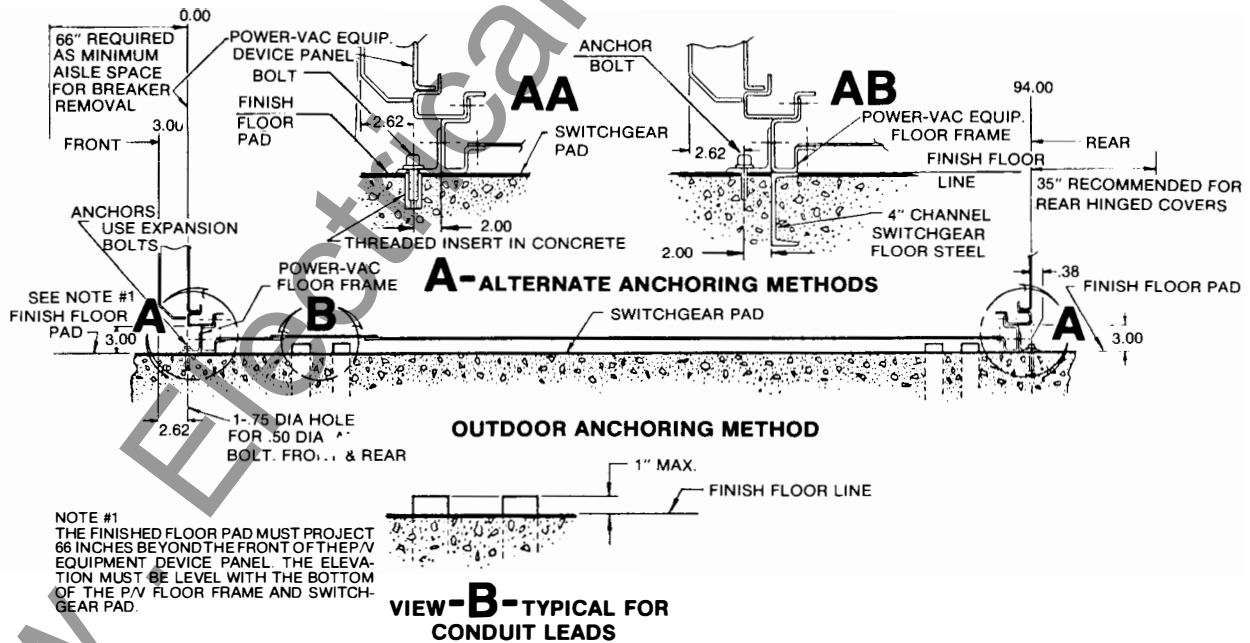

Fig. 6 Installation Details for Outdoor Power/Vac* Metal-Clad Switchgear (Continued)

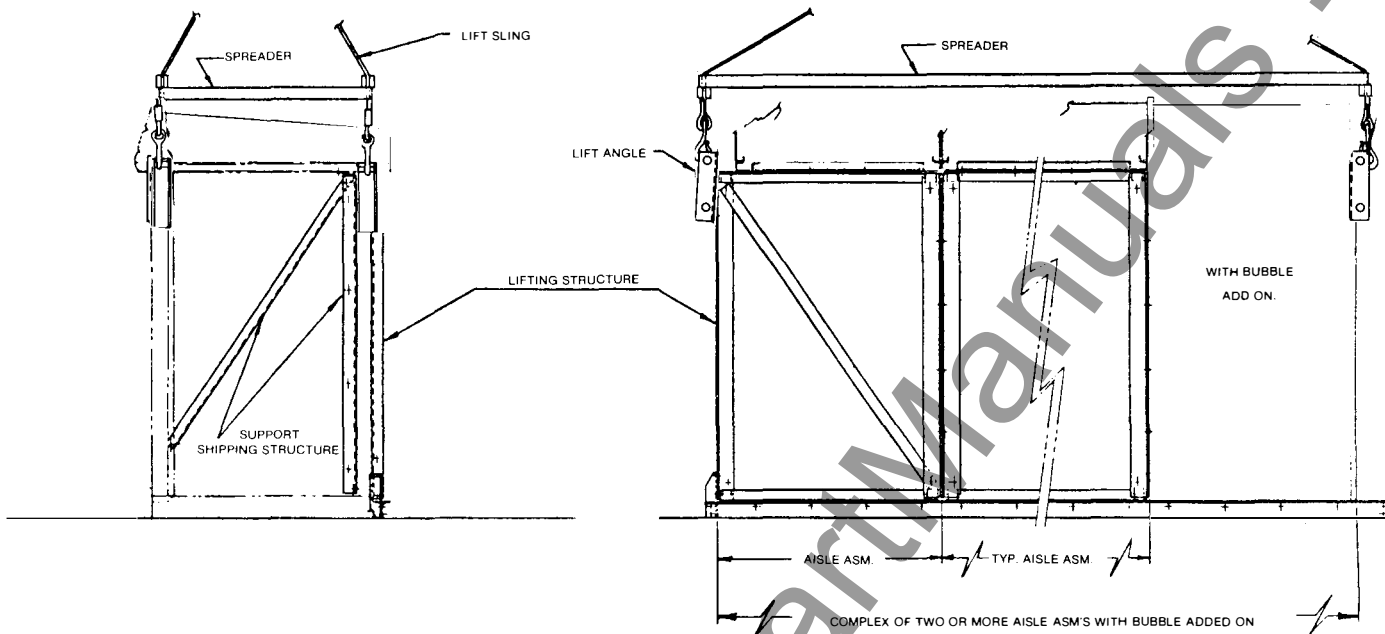

Fig. 7 (0209B4652 Rev. 0)

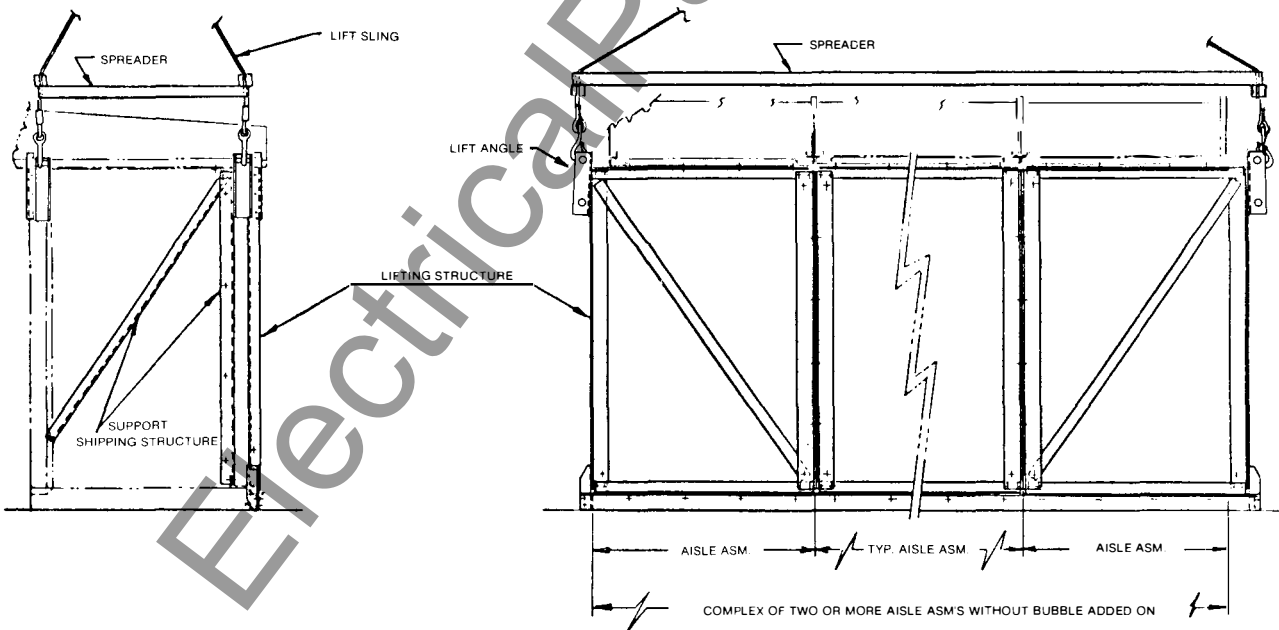

Fig. 7 (0209B4651 Rev. 0)

Fig. 7 Installation Details for Outdoor Power/Vac* Metal-Clad Switchgear with Protected Aisle

Fig. 7 (0209B4649-1 Rev. 1)

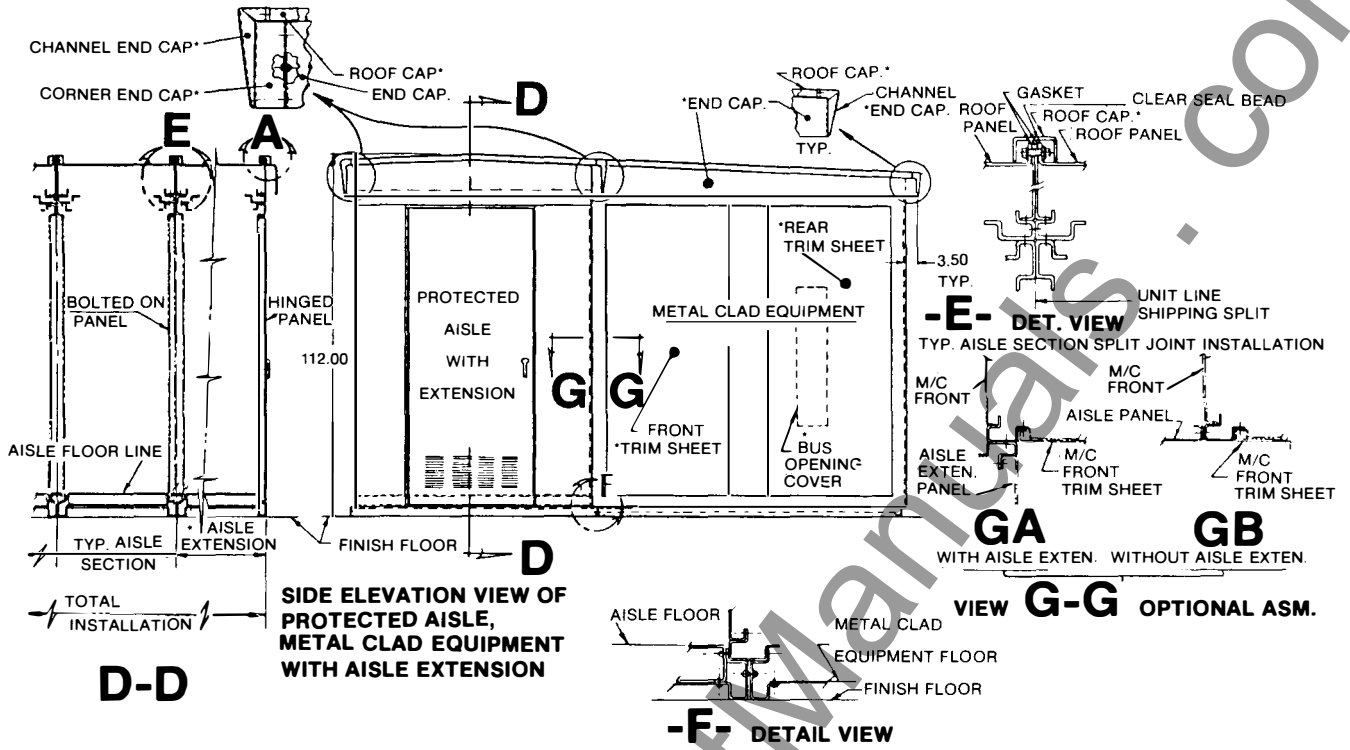

Fig. 7 (0209B4649-2 Rev. 1)

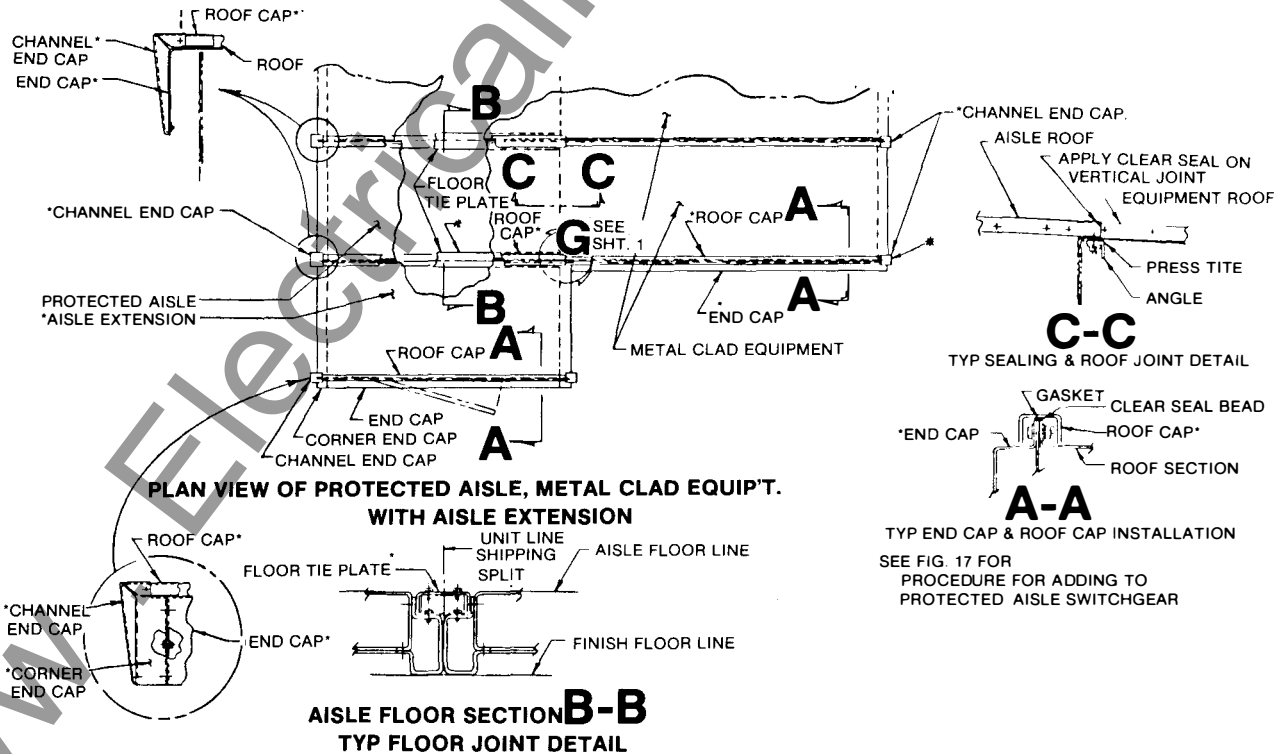

Fig. 7 Installation Details for Outdoor Power/Vac* Metal-Clad Switchgear with Protected Aisle (continued)

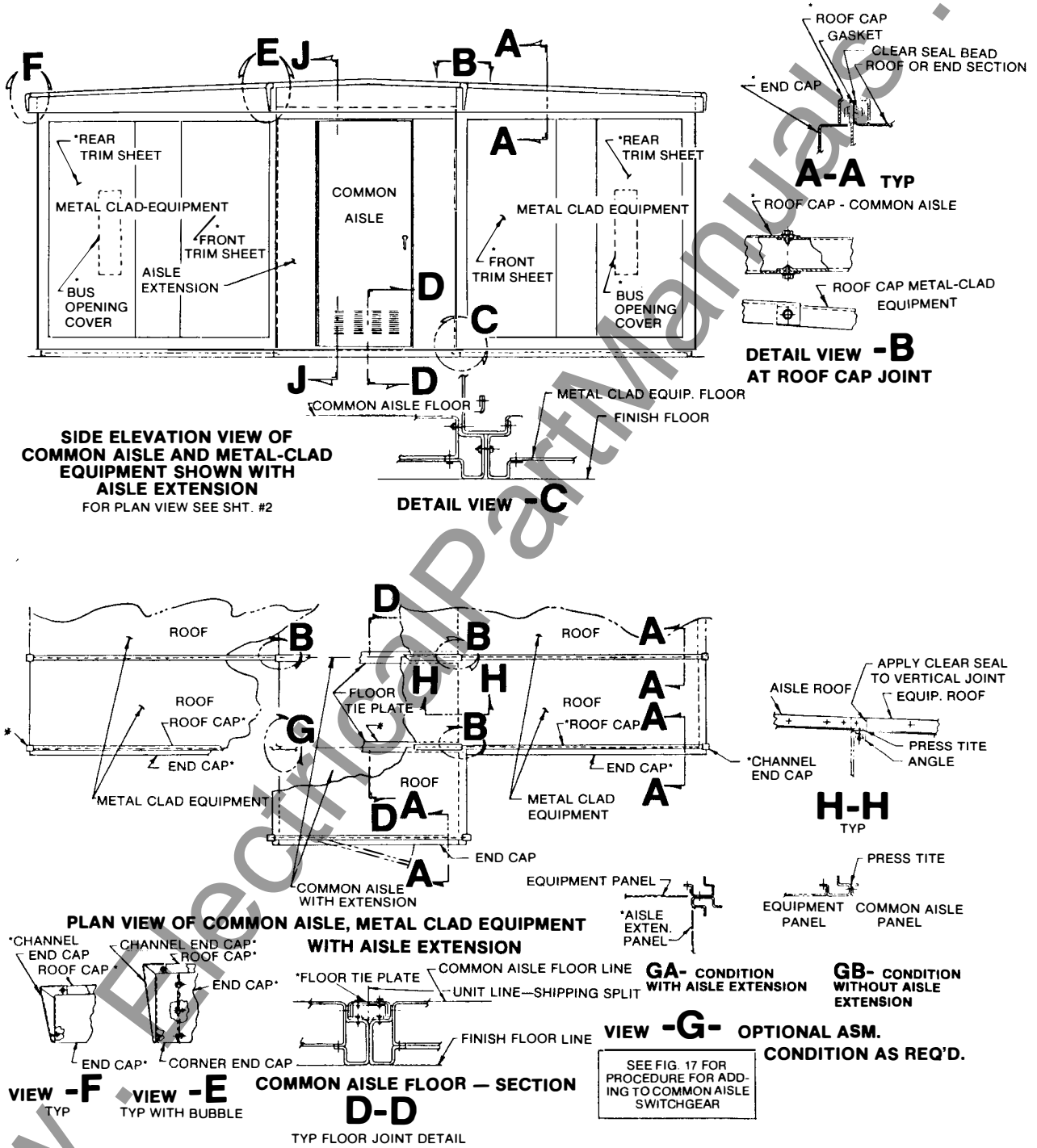

Fig. 8 (0209B4648-1 Rev. 1)

Fig. 8 (0209B4648-2 Rev. 1)

Fig. 8. Installation Details for Outdoor Power/Vac* Metal-Clad Switchgear with Aisle Extension

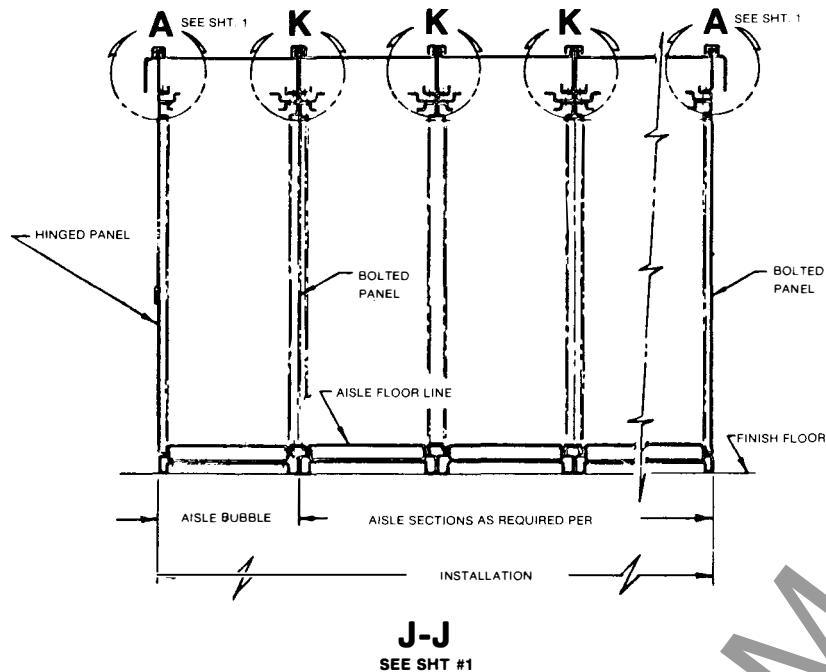

Fig. 8. Installation Details for Outdoor Power/Vac* Metal-Clad Switchgear with Aisle Extension (continued)

After final installation the device doors of both indoor and outdoor switchgear may need an alignment adjustment. The procedure for aligning device doors is outlined below.

TOOLS REQUIRED

- 1 — 12" pry bar
- 1 — 5 lb. soft face mallet

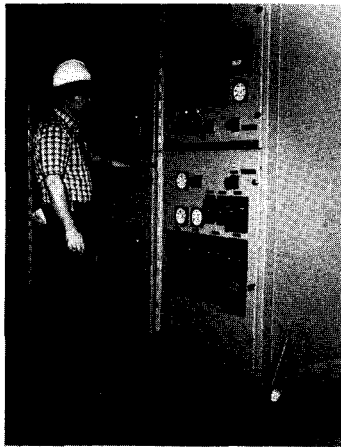

Fig. A



Fig. B

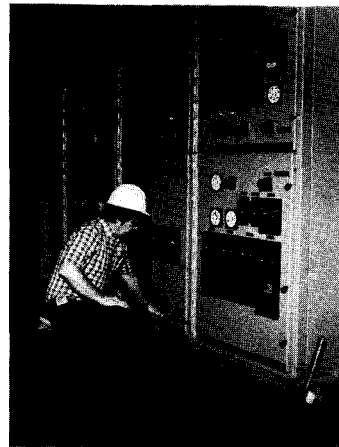

Fig. C

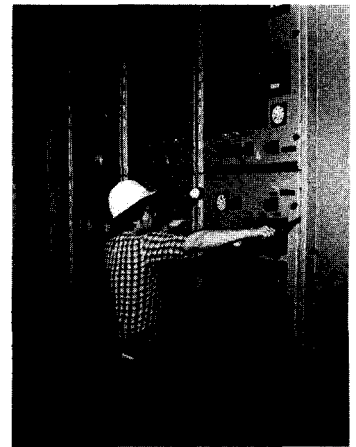

Fig. D

FIGS A & B

These figures illustrate the procedure for adjusting a door which is close at the top and at the lower right corner. To move the door down and the top to the right, place a pry bar behind the hinge near the top of the door and pull forward as shown in Fig. A. Extreme caution must be used not to spring the hinge. To move the bottom of the door to the left, place a pry bar between the frame and door, pull to the left and lightly tap the hinge near the bottom as shown in Fig. B. Adjustments are best done a little at a time to avoid springing the hinge.

FIGS. C & D

These figures illustrate the procedure for adjusting a door which is close at the bottom and at the upper right corner. To move the door up and the bottom to the right, place a pry bar behind the hinge near the bottom of the door and pull forward as shown in Fig. C. Extreme caution must be used not to spring the hinge. To move the top of the door to the left, place a pry bar between the frame and door, pull to the left and lightly tap the hinge near the top as shown in Fig. D. Adjustments are best done a little at a time to avoid springing the hinge.

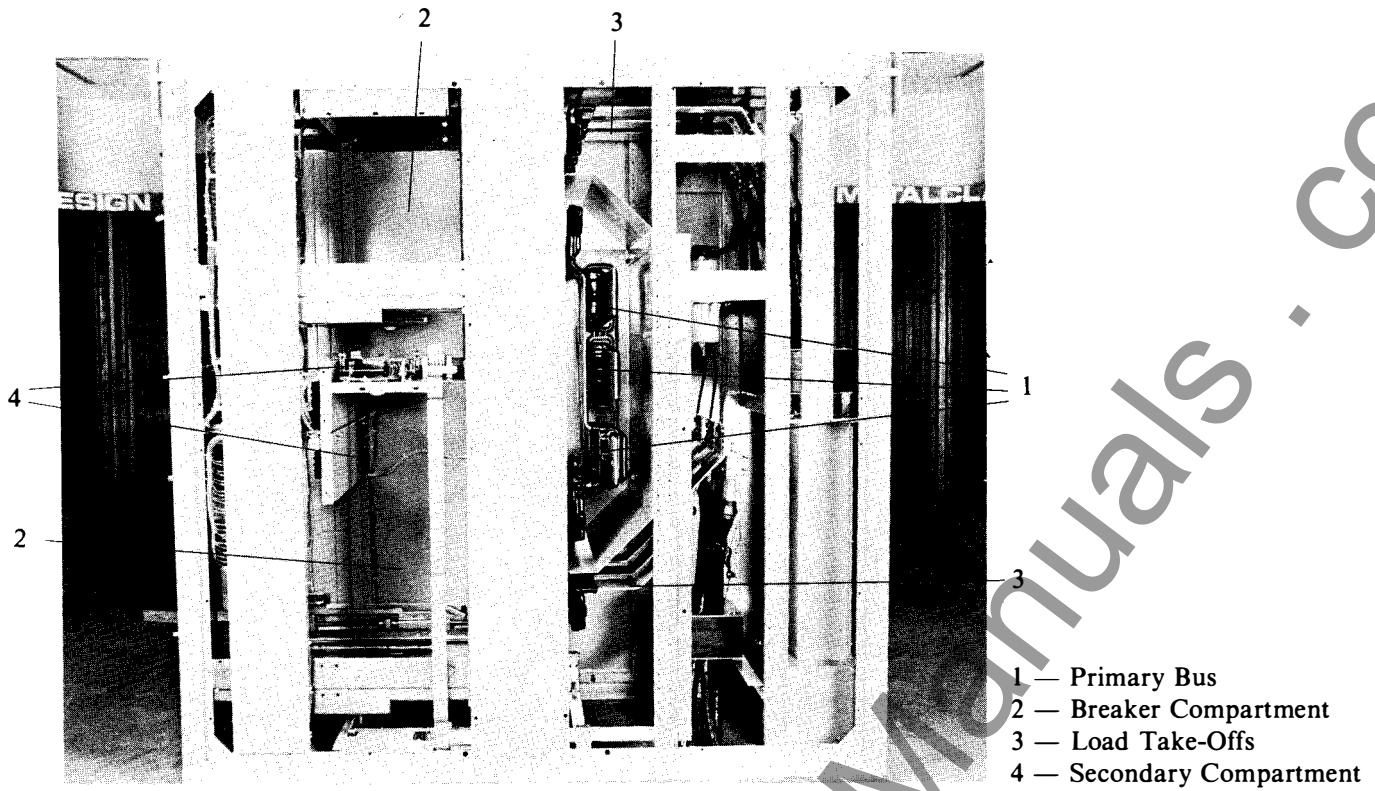

Fig. 9 (8918455A)

Fig. 9 Side Section View Power/Vac* Metal-Clad Switchgear

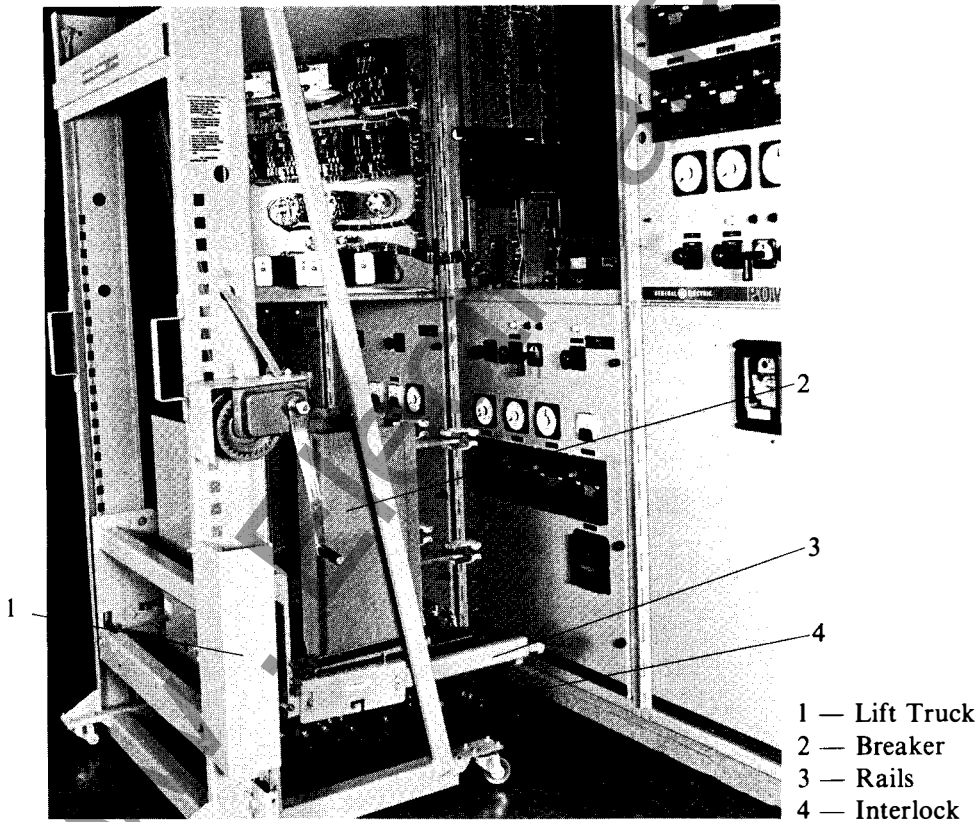

Fig. 10 (8918438C)

Fig. 10 Power/Vac* Breaker and Lift Truck

Fig. 11 (89I8455B)

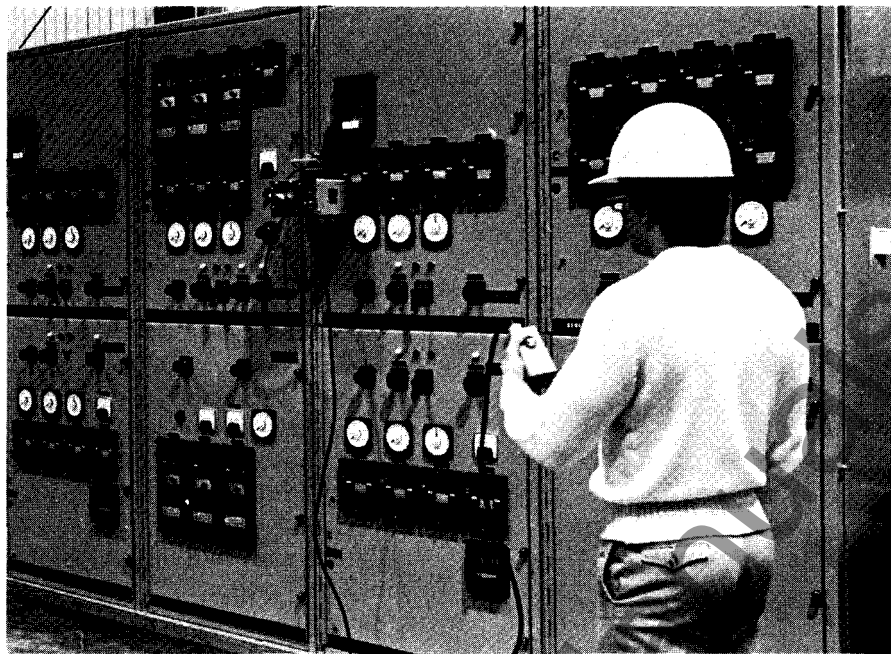

Fig. 11 Remote Racking Operator

DESCRIPTION

Each unit is made up of a secondary enclosure and a primary enclosure as shown in Fig. 9.

SECONDARY ENCLOSURE

The secondary enclosure is located at the front of the unit where the breaker is withdrawn. This enclosure consists of a compartment with a hinged panel upon which are mounted the necessary instruments, control and protective devices. The terminal blocks, fuse blocks, and some control devices are mounted inside the enclosure on the side sheets and on the internal device panel. A wiring space is provided across the top of the unit to run wires between vertical sections.

PRIMARY ENCLOSURE

The primary enclosure contains the high voltage equipment and connections. It consists of the breaker compartments, the bus compartment, the cable termination compartment, and auxiliary compartments for voltage and control power transformers. Each of these compartments is separated from the others by metal barriers for reliability and safety.

Interference Interlocks (Fig. 44) are provided on the metal-clad unit to permit only the circuit breaker with the correct voltage, continuous current, MVA and momentary rating to be inserted.

BREAKER REMOVABLE ELEMENT

The removable element consists of a Power/Vac* circuit breaker which includes an operating mechanism, interlocks, primary and secondary disconnecting devices. The Power/Vac* breakers are equipped with wheels for easy movement along the floor.

A lift truck (Fig. 10) is provided for insertion and removal of the circuit breaker from the metal-clad unit.

Power/Vac* circuit breakers of the same rating are interchangeable in their corresponding metal-clad units. An interference interlock is provided on the rear of each circuit breaker to insure that the properly rated breaker is used within the proper metal-clad unit. (See OPERATION — INTERFERENCE INTERLOCK, FIGURE 44.

For a detailed description of the Power/Vac* breaker and its operation, the breaker instruction book GEK 39671 should be consulted.

BREAKER LIFT TRUCK

For ease of breaker handling during installation and removal, a breaker lift truck is furnished as a standard

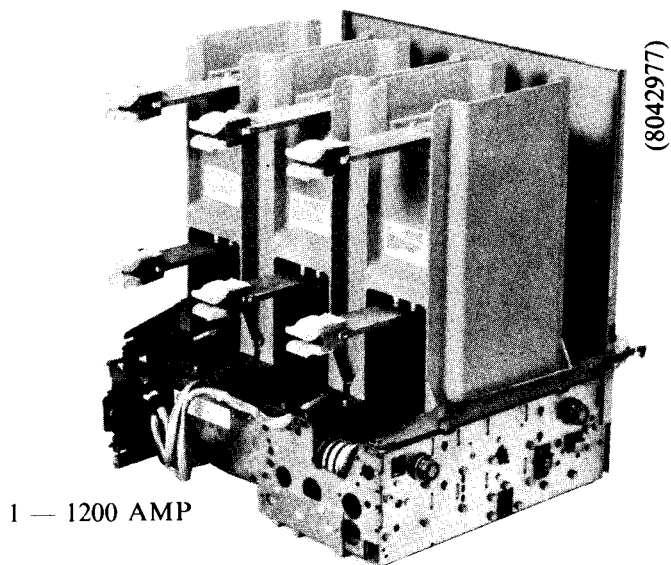

1 — 1200 AMP

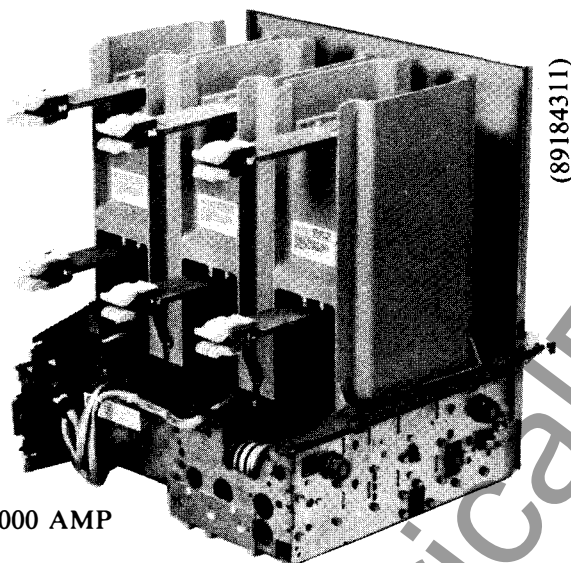

2 — 2000 AMP

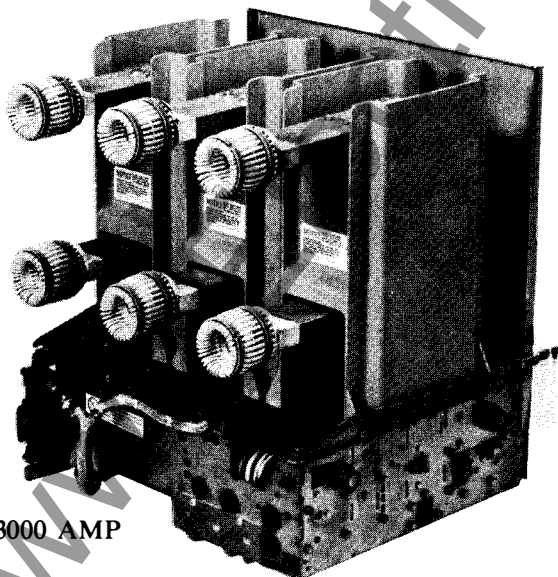

3 — 3000 AMP

Fig. 12 Primary Disconnects

accessory with each Power/ Vac* switchgear order (Fig. 10). This accessory device is used to elevate the breaker from the floor or working platform to the level of the tracks in the switchgear cubicle. Docking of the lifting device rails to the switchgear tracks is provided for maximum safety. (See OPERATION — BREAKER INSTALLATION AND REMOVAL, PAGE 36 OR GEK 90214).

BREAKER RACKING MECHANISM

When installed in the switchgear cubicle, the removable element is supported by two horizontal steel tracks, one on each side of the cubicle. The racking mechanism moves the breaker element along these tracks between the connected and test positions. This mechanism consists of heavy-duty steel jack screws which carry nuts that engage the sides of the removable element. The racking mechanism may be manually operated with the racking handle which is furnished with each equipment.

The breaker cannot be moved between the connected and test/disconnect positions unless it has been tripped. The breaker cannot be closed unless it is in the connected or test/disconnect position.

For a detailed explanation of the racking mechanism refer to description under OPERATION — CLOSED DOOR BREAKER RACKING, PAGE 39.

REMOTE RACKING OPERATOR

The optional electrically operated racking device (see Fig. 11) provides a convenient means for racking a breaker between the connected and test positions from a remote location. It is easily mounted to the breaker unit front door and is designed for quick transfer between units.

The remote racking operator is furnished in two operating voltage versions. The 115 VAC, 50/60 hertz model has a four foot electrical cord with standard three prong plug to fit a grounded receptacle or extension cord. The 230 VAC, 50/60 hertz model has a three wire four foot cord to which the purchaser applies his standard plug.

The remote racking operator is provided with a two position directional switch, an "On-Off" circuit breaker and a push button control box attached with a 30 foot extension cord.

Instructions for the remote racking operator are found in GEK 86130 (115 VAC) & GEK 86131 (230 VAC).

PRIMARY DISCONNECTS

The 1200 and 2000 ampere primary disconnects consist of two rows of silver-plated copper fingers mounted on either side of the circuit breaker studs. These fingers are held in place with a spider which positions the fingers and fastens them to the breaker. Wipe pressure is obtained by tension springs between the rows of fingers which pull them together. When the circuit breaker is connected to the metal-

clad studs, the spring force on the fingers is divided between the breaker stud and metal-clad studs. See Fig. 12.

On 3000 ampere primary disconnects, silver-plated copper fingers are positioned in a circular configuration and are supported by a non-magnetic spider. This spider spaces the fingers equally around the breaker stud and fastens them to the end of the stud. The fingers are held in contact with the breaker stud by a stainless steel garter spring. A second garter spring on the outer end of the finger provides contact pressure when the finger assembly is connected to the tube in the metal-clad unit. See Fig. 12.

BUS COMPARTMENT

The main buses are enclosed in a metal compartment with removable front covers to provide accessibility. The bus is supported and insulated by molded glass-reinforced polyester barriers which are flame retardant and track resistant. Polyester supports with porcelain sleeves may be furnished as a customer option in 5 and 15kV equipment.

Bus bars are insulated with an extruded thermoplastic insulation sleeving or an applied epoxy insulation using the fluidized bed process. All bolted joints have silver-to-silver connections for low contact resistance. Most joints are insulated with a molded polyvinylchloride boot.

CURRENT TRANSFORMER COMPARTMENT

Current transformers are mounted over the primary bushings in the rear of the breaker compartment and are isolated from the breaker by the shutter barrier. They are front-accessible by removal of the shutter barrier. The equipment must be de-energized before any component is touched or serious injury could result.

PRIMARY TERMINATION SPACE

The primary termination space of each breaker unit is isolated from the other equipment by metal barriers. Space is provided in this compartment for connecting the purchaser's primary cable by means of potheads or clamp-type terminals. Two-hole NEMA drilling for two cables per phase is provided at all cable connection points.

In double breaker vertical sections, a steel duct serves as a pull-box and barrier to separate the two outgoing cable circuits.

The primary termination space of a unit is accessible by removal of the bolted rear cover.

VOLTAGE TRANSFORMERS

Voltage transformers are located in an auxiliary unit. Up to three transformers can be mounted on a movable carriage equipped with primary and secondary disconnecting devices. When the voltage transformers are disconnected, they are at a safe striking distance from all live parts of the switchgear. In addition, a grounding device is provided which contacts the fuses when the voltage transformers are disconnected, effectively discharging the transformers. In this position the transformer fuses may be safely removed and replaced. A barrier mounted at the rear of the carriage moves with the carriage to a position in front of the stationary part of the primary disconnect device, providing a safe striking distance from all live parts. See Fig. 14.

CURRENT-LIMITING FUSES AND CONTROL POWER TRANSFORMER

Current-limiting fuses with high interrupting rating are sometimes used in metal-clad switchgear to protect small transformers or circuits where circuit breakers cannot be economically or functionally justified.

Fig. 14 (8918432D)

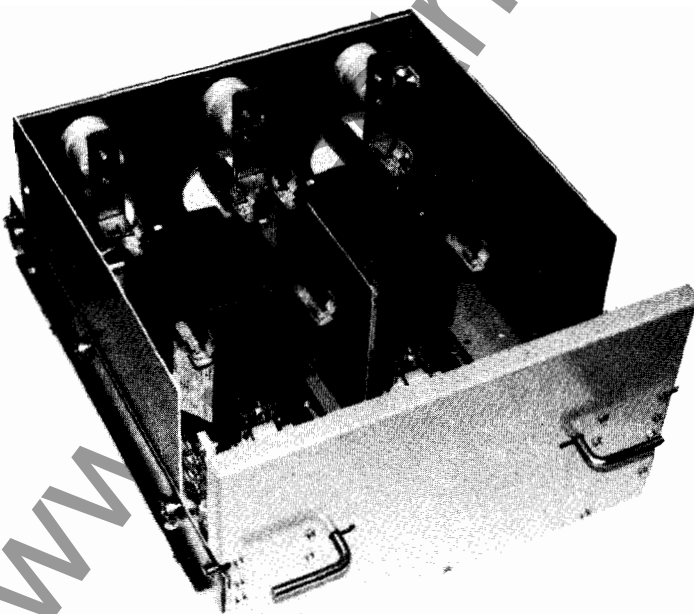

Fig. 14 Voltage Transformer Drawout Carriage

Fig. 15 (8919432B)

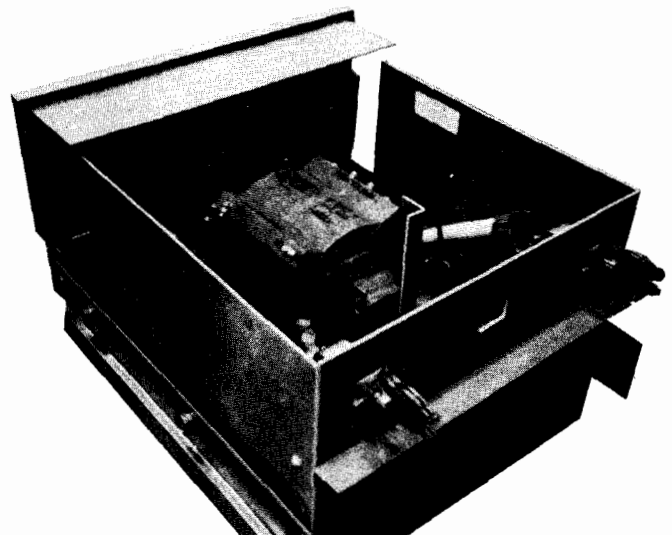

Fig. 15 Control Power Transformer Drawout Carriage

The fuses are mounted on a movable carriage equipped with primary and secondary disconnecting devices. Single phase control power transformers of 15kVA and smaller and their secondary breaker are mounted on the carriage with the fuses. See Fig. 15. Larger control power transformers, up to 37.5 kVA single phase or 45 kVA 3 phase, are located in the cable compartment behind their associated fuse carriage and their secondary breaker is located behind a hinged cover on the upper cable compartment.

When the fuses are disconnected, they are at a safe striking distance from all live parts of the switchgear. In addition a grounding device is provided which contacts the fuses after they are disconnected, effectively removing any static charge from the fuses. In this position the fuses may be safely removed and replaced. The disconnecting devices are capable of interrupting transformer magnetizing current, but should not be used to interrupt load current. Mechanical or key interlocks are applied to prevent operating the disconnecting device while the load is connected. This is generally accomplished by interlocking so that the transformer secondary breaker must be locked in the open position before the disconnecting device can be connected or disconnected.

Current-limiting fuse and control power transformer roll-outs are located in auxiliary units.

DUMMY REMOVABLE ELEMENT, TYPE PVD (GEK 39678)

Dummy removable elements are used as a means of isolating circuits or bus sections where operation is infrequent and a circuit breaker cannot be economically justified. The device consists of a circuit breaker mechanism frame and primary insulator supports with six primary studs including disconnecting devices. Copper rods are bolted in the location normally occupied by vacuum interrupters. The stationary structure is the same as for a circuit breaker. When the device is fully racked in, it connects the top set of metal-clad primary disconnects to the bottom set.

An interlock system, consisting of a side extension identical to the positive interlock extension of a standard circuit breaker when the breaker is closed, insures that the dummy element cannot be racked in or out unless all sources to which it may connect are de-energized.

A key lock is provided on the dummy element. It takes a key which becomes available only when all sources to which the dummy might connect are de-energized. When the key is available, the key interlock can be operated to withdraw the positive interlock extension. The dummy element now looks like an open breaker, and it can be racked in or out. As long as the positive interlock extension is withdrawn, the key is captured and it cannot be released unless the dummy element is in the CONNECTED or TEST position or completely withdrawn. Hence, the sources to which the dummy may connect cannot be re-energized until the dummy is in one of these three positions.

The key for the dummy element interlock will usually be obtained from a transfer lock at which all the source keys are accumulated and captured before the dummy element key can be obtained.

GROUND AND TEST DEVICE

This device is designed to make either the upper or lower primary conductors in the breaker unit readily accessible. The type PVV manual ground and test device, provides a convenient means of grounding the cables or the bus in order to safeguard personnel who may be working on the cables or the equipment. The device can be used for applying power for high-potential tests or for fault location. It can be used to measure insulation resistance (megger). By using voltage transformers, it can also be used for phasing out cables. Refer to the instruction book provided for this device. If "hotsticks" are used, they should be insulated. See GEK 39686.

CAUTION — NOTE THAT THE MAIN SWITCHGEAR BUS IS CONNECTED TO THE LOWER STUDS WHEN THE DEVICE IS INSTALLED IN AN UPPER COMPARTMENT AND TO THE UPPER STUDS WHEN THE DEVICE IS INSTALLED IN A LOWER COMPARTMENT. Refer to Fig. 9, which shows a side section view of the switchgear, for clarification.

In addition to the device described above, there is available the deluxe power-operated type GMV device which has a self-contained bus or line selector switch and a separately controlled, power operated, three-phase grounding switch. The GMV device is a dead-front design with mechanical and electrical interlocks, provision for remote control and plug-type cable testing and phasing. The primary conductors required for grounding are self-contained, with no external cable connections required.

The GMV device is designed for maximum safety to personnel while accomplishing all the basic required grounding and testing functions. Refer to the instruction book GEK 39684 for more details.

INSTALLATION

Before any installation work is done, consult and study all drawings furnished by the General Electric Company for the particular requisition. These drawings include arrangement and floor plan drawings, elementary, connection and inter-connection diagrams and a device summary.

Occasionally additional shipping members are installed in the primary area to protect against shipping damage.

CAUTION — Shipping braces must be removed prior to energizing. Shipping braces are marked with yellow labels. Shipping braces may be applied to devices as well as to current-carrying conductors.

After the shipping braces have been removed, all joints must be properly tightened and insulated before energizing the bus.

Mats, screens, railings, etc. which are external to the switchgear, but which may be required to meet any local codes, must be furnished by the purchaser.

LOCATION

The recommended aisle space required at the front and at the rear of the equipment is shown on the floor plan drawing furnished for the particular requisition. The space at the front must be sufficient to permit the insertion and withdrawal of the circuit breakers, and their transfer to other units. No part of a foundation "PAD" or "SILL" may extend more than 3 inches beyond the front of the equipment.

The space at the rear must be sufficient for installation of cables, and for inspection and maintenance.

ANCHORING

INDOOR EQUIPMENT — FLOOR PREPARATION

The station floor must be strong enough to prevent sagging due to weight of the switchgear structure and to withstand the impact stress caused by the opening of the circuit breakers under short circuit conditions. The impact loading is approximately $1\frac{1}{2}$ times the static load.

Suitable means must be provided by the purchaser for anchoring the equipment to the floor. It is essential that the floor be level to avoid distortion of the switchgear structure and that the equipment be completely aligned prior to final anchoring. The recommended floor construction is shown in Fig. 5. The floor channels must be level and straight with respect to each other. Steel shims should be used for final leveling of the switchgear, if necessary. Care should be taken to provide a smooth, hard, and level floor under and in front of the units to facilitate installation and removal of the breaker. If the floor is not level and flush with the floor channels, it will be difficult to handle the breaker because it

will not be level with respect to the stationary element.

The switchgear structure can be secured by bolting it to the floor channels using at least 5/8 inch bolts at locations shown in Fig. 5. Plug welding can also be used at the same locations if desired.

Provision should be made in the floor for conduits for primary and secondary cables, located as shown on the floor plan drawing furnished for the particular requisition. If desired, the conduits may be installed before the switchgear. Consideration should be given to conduits which might be required for future connections. Conduits must extend no more than one inch above the finished floor prior to the installation of the switchgear. If shipped in more than one section, shipping sections must be assembled in the proper sequence due to the location of conduits. The left-hand section of a switchgear line-up must be positioned in its final location first. Then the section located immediately to the right must be positioned as close as the lifting members permit with the front in alignment with the first section. Remove the lifting members and then push or jack the unit to the left until it is flush with the first section. Be sure to distribute the forces over the side frame using appropriate timbers so as not to deform or damage the surface of the structure.

OUTDOOR EQUIPMENT

Switchgear support should be concrete or reinforced concrete with depth, fill, drainage, etc., according to recommended foundation design for the loading, type of construction, and local conditions involved. The base furnished with the switchgear should be supported on a level surface over the full area of the switchgear. Steel supporting members should be furnished if required for leveling the foundation and supporting the switchgear. Refer to Fig. 6 for recommended foundation and anchoring.

Primary and secondary conduits should be installed in accordance with the requisition drawings, before the equipment is put into place. Conduits must extend no more than one inch above the finished floor prior to the installation of the switchgear.

When outdoor pieces of equipment are shipped in more than one section, the roof joint between the sections must be assembled as shown in Fig. 7. Shipping sections must be assembled in the proper sequence due to the location of conduits. The left-hand section of a switchgear line-up must be positioned in its final location first. Then the section located immediately to the right must be positioned as close as the lifting members permit with the front in alignment with the first section. Remove the lifting members and then push or jack the unit to the left until it is flush with the first section. Be sure to distribute the forces over the side frame using appropriate timbers so as not to deform or damage the surface of the structure.

Fig. 16

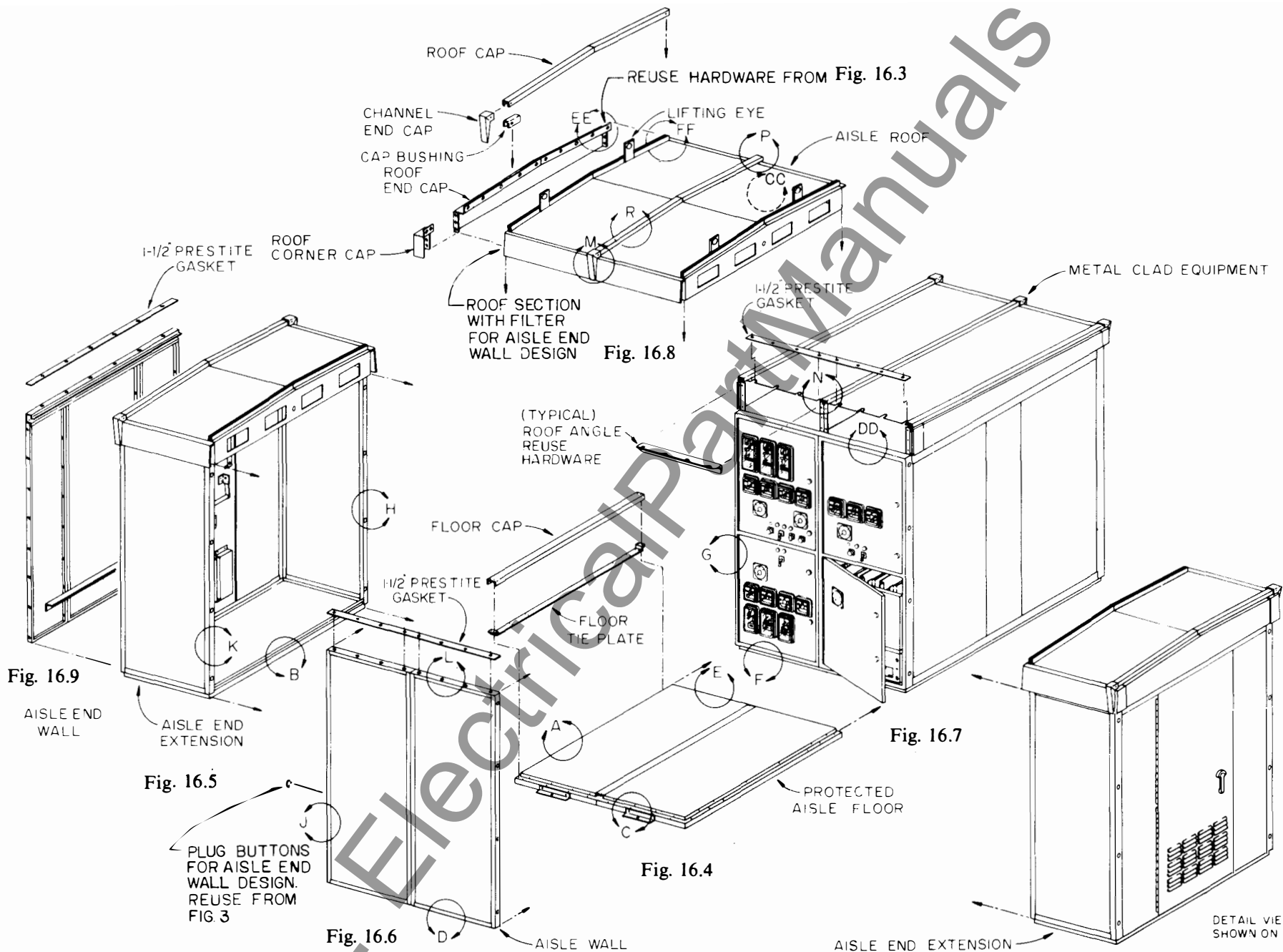

Fig. 16.9

Fig. 16.8

Fig. 16.7

Fig. 16.4

Fig. 16.6

Fig. 16.5

DETAIL VIEWS SHOWN ON SHEET 3

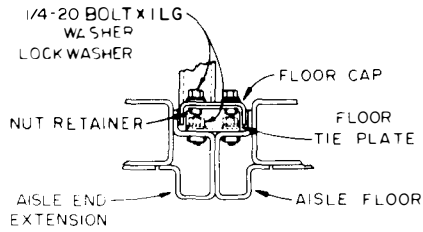

ASSEMBLY OF DETAILS A&B

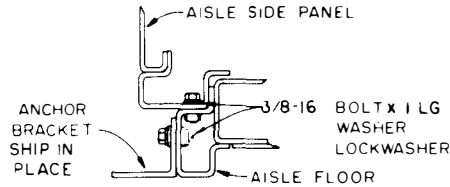

ASSEMBLY OF DETAILS C&D

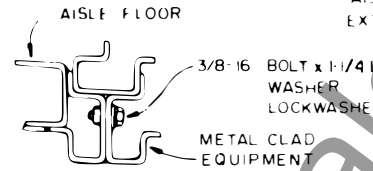

ASSEMBLY OF DETAILS E&F

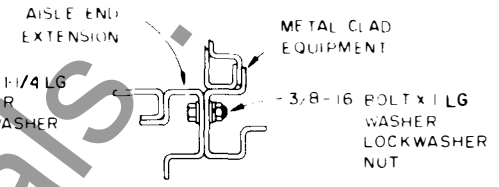

ASSEMBLY OF DETAILS G&H

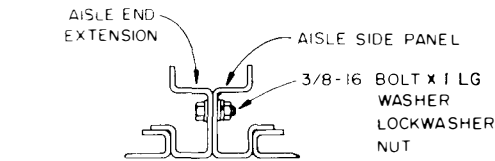

ASSEMBLY OF DETAILS J&K

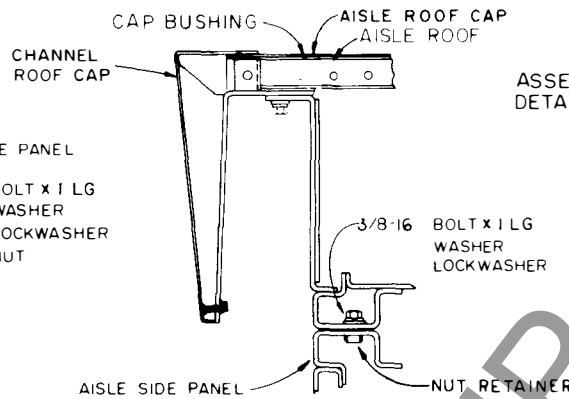

ASSEMBLY OF DETAILS L&M

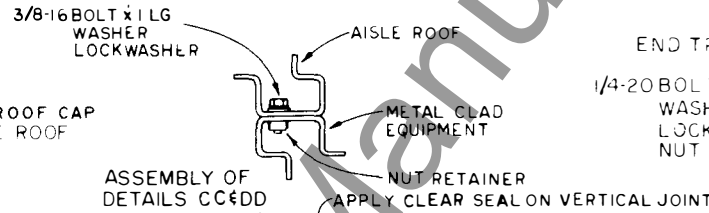

ASSEMBLY OF DETAILS CC&DD

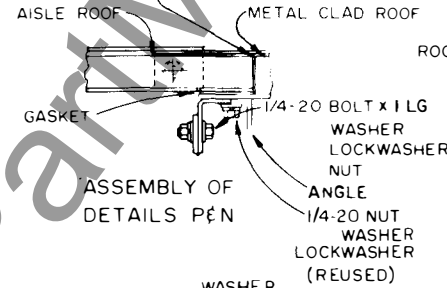

ASSEMBLY OF DETAILS P&N

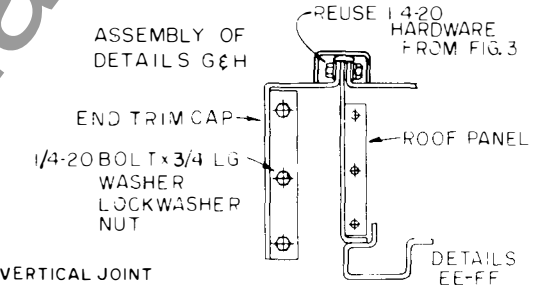

DETAILS EE-FF

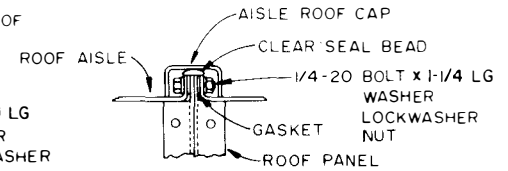

DETAIL R WITH END CAP REMOVED

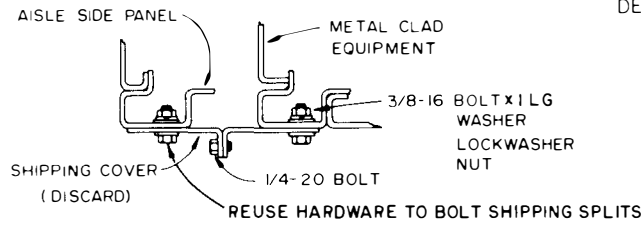

SHIPPING ASSEMBLY OF DETAILS S&T

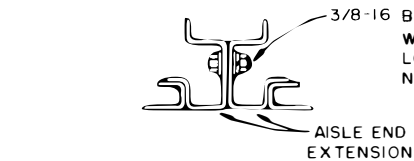

SHIPPING ASSEMBLY OF DETAILS Y&Z

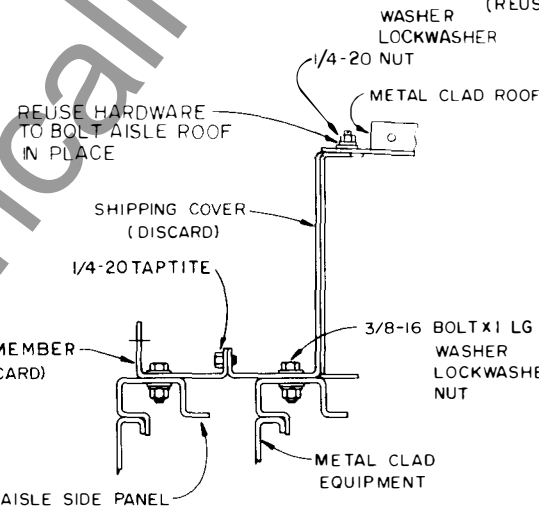

SHIPPING ASSEMBLY OF DETAILS U&V

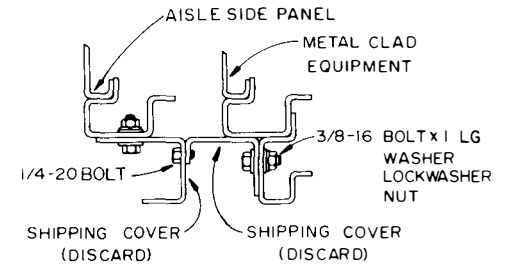

SHIPPING ASSEMBLY OF DETAILS W&X

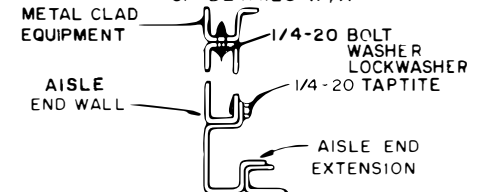

SHIPPING ASSEMBLY OF DETAILS AA&BB

OUTDOOR EQUIPMENT WITH PROTECTED AISLE

1. Remove aisle front wall from the front of the metal-clad switchgear equipment, discard all yellow shipping covers on aisle wall and front of metal-clad equipment except lifting members. Re-use 3/8-16 hardware. See Fig. 16.1, details S-T, U-V, W-X. Since the relay and instrument cases are not weatherproof, the control panels should be protected from inclement weather until the installation of the aisle enclosure is completed.
2. Lay down aisle floor in front of each metal-clad unit (Fig. 16.4). Secure at each unit line with tie plate and floor cap per detail A-B. Secure to metal-clad per detail E-F.
3. For aisle end wall design, disassemble channel cap, cap bushing, roof cap, end trim and corner cap (Fig. 16.3). Reassemble at end of aisle that has the aisle end wall. Re-use 1/4-20 hardware and plug buttons. Fig. 16.8 and detail EE-FF.
4. Disassemble aisle end extensions (Fig. 16.2, detail Y-Z) or aisle end extension and aisle end wall. Fig. 16.3, detail BB & AA. Do not remove shipping support from aisle end wall.
5. Position aisle end extension(s) and/or aisle end wall(s) at ends of the line up. Secure aisle extension to aisle floor and metal-clad Fig. 16.5, detail A-B, H-G. Secure aisle end wall per detail AA-BB.
6. Set up aisle wall and secure to aisle floor, aisle end extension(s), aisle end wall(s) and shipping split. Figures 16.4, 16.5, 16.6 details J-K, C-D, AA-BB.
7. Apply prestite gasketing material to top of aisle wall (Fig. 16.6), metal-clad roof (Fig. 16.7), and aisle end wall (Fig. 16.9). Punch holes in gasket with drift pin.
8. Remove roof angle (re-use 1/4-20 hardware) and set aisle roofs in place, taking care to align the lap joint between the aisle and switchgear roof assemblies before contacting prestite gasket. Secure roof sections to each other, to aisle wall and to metal-clad per Figures 16.6 and 16.7, details R, L-M and P-N.
9. Apply RTV clear seal and assemble roof caps, cap bushings and channel end caps. Fig. 16.8 details L-M, P-N.
10. After steel erection is complete, check to certify that all bolted, butt or overlapped joints are resistant to water leaks. A source of outside light in a darkened aisle is an indication that RTV108 clear seal should be applied to the exterior surfaces.
11. Assemble Hayco grommets in the aisle roof sections.
12. Assemble and wire the light switches, receptacles, lamp sockets, etc. in accordance with the wiring diagrams furnished for the equipment.

13. Anchor the base of the protected aisle assembly to the concrete pad using the anchor clips provided. Install anchor bolts in accordance with the requisition drawing.

OUTDOOR EQUIPMENT WITH COMMON AISLE

1. Remove and discard the yellow shipping covers on front of metal-clad equipment. Since the relay and instrument cases are not weatherproof, the control panel should be protected from inclement weather until the installation of the aisle enclosure is completed.
2. Lay down aisle floor in front of each metal-clad unit of first switchgear line-up. Secure to metal-clad per detail E-F.
3. Move second switchgear line-up into position and secure to aisle floor per detail E-F. After the switchgear is secured to the aisle floor, it should be anchored to the concrete pad using the anchor clips provided. Install anchor bolts in accordance with the requisition drawing.
4. For aisle end wall design, disassemble channel cap, cap bushing, roof cap, end trim and corner cap (Fig. 16.3). Reassemble at end of aisle that has the aisle end wall. Re-use 1/4-20 hardware and plug buttons. Fig. 16.8 and detail EE-FF.
5. Disassemble aisle end extensions (Fig. 16.2, detail Y-Z) or aisle end extension and aisle end wall. Fig. 15.3, detail AA & BB. Do not remove shipping support from aisle end wall.
6. Position aisle end extension(s) and/or aisle end wall(s) at ends of the line-up. Secure aisle extension to aisle floor and metal-clad Fig. 16.5, detail A-B, H-G. Secure aisle end wall per detail AA-BB.
7. Apply prestite gasketing material to top of metal-clad roof (Fig. 16.7), and aisle end wall (Fig. 16.9). Punch holes in gasket with drift pin.
8. Remove roof angle (re-use 1/4-20 hardware) and set aisle roofs in place taking care to align the lap joint between the aisle and switchgear roof assemblies before contacting prestite gasket. Secure roof sections to each other and to metal-clad per Figures 16.6 and 16.7, details R, L-M, and P-N.
9. Apply RTV clear seal and assemble roof caps, cap bushing and channel end caps. Fig. 16.8, details L-M, P-N.
10. After steel erection is complete, check to certify that all bolted, butt or overlapped joints are resistant to water leaks. A source of outside light in a darkened aisle is an indication that RTV108 clear seal should be applied to the exterior surfaces.
11. Assemble Hayco grommets in the aisle roof sections.

12. Assemble and wire the light switches, receptacles, lamp sockets, etc. in accordance with the wiring diagrams furnished for the equipment.

BREAKER REMOVABLE ELEMENT

Before installing or operating the removable element, consult the circuit breaker instruction book GEK 39671 for directions on installation and inspection.

The operation of the racking mechanism, positive and negative interlocks and associated features are described under OPERATION OF EQUIPMENT and should be reviewed before installing removable element.



Fig. 17 (8043125)

Fig. 17 Test Cabinet

TEST CABINET

The test cabinet, Fig. 17, is used to operate a breaker that has been removed from the metal-clad equipment. It should be installed on the wall at a location where maintenance and testing of the breaker can be conveniently done. Conduits must be installed for cables to supply control power for testing. Make certain that the green ground conductor is connected to the electrical ground.

ADDITION OF UNITS TO EXISTING EQUIPMENT

Before adding units to existing equipment, consult and study all drawings furnished with the equipment. In addition to the usual drawings furnished with new equipment, special drawings may be furnished covering complicated or special assembly work. Also, check to make sure all necessary parts are on hand.

BEFORE ANY COVERS ARE REMOVED OR ANY DOORS OPENED WHICH PERMIT ACCESS TO THE PRIMARY CIRCUITS, IT IS ESSENTIAL THAT THE

CIRCUIT OR CIRCUITS BE DE-ENERGIZED AND BREAKERS BE WITHDRAWN TO THE TEST POSITION AND TAGGED.

Fig. 18b indicates that special procedures required to add new metal-clad units to outdoor equipment without a protected aisle, and Fig. 18a indicates the special procedures required to add new metal-clad units to outdoor equipment with a protected aisle. For indoor equipment, it is usually necessary only to remove the end trim sheets and to reassemble them on the new units after these are located and bolted to the existing units. Otherwise, the installation procedure is the same as described above.

When the units are in place and bolted together, assemble the main bus and other primary connections per the instructions below.

Secondary wiring and control bus connections should be made in accordance with the wiring diagrams furnished with the equipment.

PROCEDURE FOR ADDING TO PROTECTED/Common AISLE

- A. REMOVE THE FOLLOWING ITEMS FROM THE FROM THE EXISTING PROTECTED/Common AISLE AND METAL-CLAD SECTION AND MOVE TO THE END OF THE NEW ADDITION. (EXCEPT AS NOTED)
 1. CHANNEL END CAPS
 2. ROOF CAPS
 3. METAL-CLAD END CAP(S)
 4. FLOOR TIE PLATE
 5. AISLE END BUBBLE ENCLOSURE
 6. METAL-CLAD FRONT TRIM SHEET — DISCARD
 7. METAL-CLAD REAR TRIM SHEET — DISCARD
 8. BUS OPENING COVER — DISCARD
- B. TO INSTALL NEW METAL-CLAD UNITS.
 1. SET NEW UNITS IN PLACE & BOLT TOGETHER.
 2. ASSEMBLE BUS OPENING COVER, FRONT & REAR TRIM SHEETS.
 3. ASSEMBLE NEW ROOF CAPS & REAR CHANNEL END CAP.
 4. ASSEMBLE GROUND BUS SPLICE BETWEEN EXISTING & NEW GROUND BUS.
 5. ASSEMBLE BUS BARS & INSULATING BOOTS.
- C. TO INSTALL NEW PROTECTED AISLE UNITS
 1. APPLY PRESTITE SEALER TO METAL-CLAD ROOF.
 2. INSTALL NEW AISLE ASSEMBLY, BOLT IN PLACE
 3. ASSEMBLE NEW ROOF CAP & CHANNEL END CAP.
 4. ASSEMBLE NEW FLOOR TIE PLATE.
 5. REASSEMBLE ITEMS A-1 THROUGH A-5

Fig. 18a Outdoor Metal-Clad Switchgear Addition of Units to a Line-up (Refer to Fig. 7 and 8)

PROCEDURE FOR ADDING TO OUTDOOR (NO AISLE)

- A. REMOVE THE FOLLOWING ITEMS FROM THE EXISTING METAL-CLAD SECTION AND MOVE TO THE END OF THE NEW ADDITON. (EXCEPT AS NOTED)
 1. CHANNEL END CAPS
 2. ROOF CAPS
 3. METAL-CLAD END AND CORNER CAP
 4. METAL-CLAD FRONT TRIM SHEET — DISCARD
 5. METAL-CLAD REAR TRIM SHEET — DISCARD
 6. BUS OPENING COVER — DISCARD
- B. TO INSTALL NEW METAL-CLAD UNITS.
 1. SET NEW UNIT IN PLACE & BOLT TOGETHER.
 2. ASSEMBLE BUS OPENING COVER, FRONT & REAR TRIM SHEETS.
 3. ASSEMBLE NEW ROOF CAPS & FRONT & REAR CHANNEL END CAPS.
 4. ASSEMBLE GROUND BUS SPLICE BETWEEN EXISTING & NEW GROUND BUS.
 5. ASSEMBLE BUS BARS & INSULATING BOOTS.
 6. REASSEMBLE A-1 THROUGH A-3

Fig. 18b Outdoor Metal-Clad Switchgear with Protected Common Aisle — Addition of Units to Line-up (Refer to Fig. 6)

CONNECTIONS

The main bus bars and other connection bars will be either copper or aluminum. In either case, the contact surfaces will be silver surfaced or equivalent. Do not use unplated copper or aluminum bars exception, ground bus. All field-assembled joints in primary conductors, regardless of material or method of insulation, should be made as described below:

INSTRUCTIONS FOR APPLICATION OF BLACK & RED GREASES (0282A2048 PTS 001, 002, 009, 010, 012) METAL-CLAD SWITCHGEAR.

1a. BOLTED JOINTS — FACTORY ASSEMBLED — ADJACENT TO A50H404 FLUID BED OR A50H225 BAYBLEND BUS SLEEVING OR A50H229 H.V. TAPE INSULATIONS.

First, wipe contact surfaces with a clean, soft, dry, lint-free cloth to remove dirt and grease from silvered areas. Do not use any abrasives such as sand paper, emery cloth or steel wool for this purpose. Avoid handling of the contact surfaces after cleaning.

Then apply a sufficient quantity of D50H47 **BLACK** grease (0282A2048 P002) to all surfaces being bolted together to cover them completely. Sufficient D50H47 must be evenly applied so that excess will be squeezed out along the edges of the conductors when the bolts are tightened. Wipe off excess grease. Be sure none contaminates any insulation surface. NOTE: In the region where the edge of the silver plating is not covered by insulation, e.g. ground bus and ground risers, the D50H47 must be applied to overlap this interface for a minimum of 1/2 inch.

Finally, after the connection bolts have been tightened to the proper torque (Fig. 19), a thin coat of D50H47 **BLACK** grease must be applied to all external surfaces of the joint (including bar edges and hardware). This applies to all silvered connections, booted or uninsulated.

NOTE: Tape-insulated and non-silvered connections do not require D50H47 on EXTERNAL surfaces, but require a thin coating on all INTERNAL surfaces.

1b. BOLTED JOINTS — FIELD ASSEMBLED — ADJACENT TO A50H404 FLUID BED OR A50H225 BAYBLEND BUS SLEEVING OR A50H229 H.V. TAPE INSULATIONS.

Prepare contact surfaces and apply D50H47 **BLACK** grease as described in Part 1A of this instruction. Whenever possible, splice plates and hardware should be assembled in the same position they will be when the joint is completed in the field. The external surfaces, including hardware, must be protected with a thin coat of D50H47 just prior to shipment.

1c. CONDUCTORS SHIPPED "XS"

The contact surfaces of bus and connection bars shipped "XS" must be prepared as described in Part 1a of this instruction and covered with a thin coat of D50H47 just prior to shipment.

2a. SLIDING CONNECTIONS, (STATIONARY PRIMARY DISCONNECT DEVICES, BREAKERS AND ROLLOUTS)

First, wipe contact surfaces with a clean, soft, dry, lint-free cloth to remove dirt and grease from silvered areas. Do not use any abrasives such as sand paper, emery cloth or steel wool for this purpose. Avoid handling of the contact surfaces after cleaning.

Then apply a thin coat of D6A15A2 **RED** grease to the front two inches of all breaker and rollout primary disconnect devices. Cover all surfaces, front, sides, top and bottom evenly.

2b. SLIDING CONNECTIONS, (STATIONARY GROUND CONTACT CLUSTER)

Prepare the contact surfaces as described in Part 3a of this instruction, giving special attention to the facing curved surfaces to be sure no sharp edges or burrs exist at the narrowest dimension. Apply a thin coat of D6A15A2 **RED** grease to the facing curved surfaces for a distance of no less than 3/4 inch centered around the point of narrowest dimension.

2c. SLIDING CONNECTIONS, (MOVABLE PRIMARY DISCONNECT DEVICES-ROLLOUTS)

Before assembling the contact fingers, prepare the contact surfaces (double thickness segment) of the primary tangs and apply a thin coat of D6A15A2 **RED** grease as described in Part 3a of this instruction. Assemble and pin the contact fingers in place. Apply a thin coat of D6A15A2 to the facing curved surfaces of the contact fingers as described in Part 3b of this instruction.

Bolt Size	Torque Foot Pounds
1/4 - 20	5 - 7
1/2 - 16	20 - 25
1/2 - 13	30 - 35
5/8 - 11	43 - 47

The material may be aluminum or copper

Fig. 19 Bolt Torque Values for Power/Vac Switchgear MAIN BUS ASSEMBLY

The procedure shown below should be followed when assembling the main bus at shipping splits or when adding new units to existing equipment. (Fig. 20).

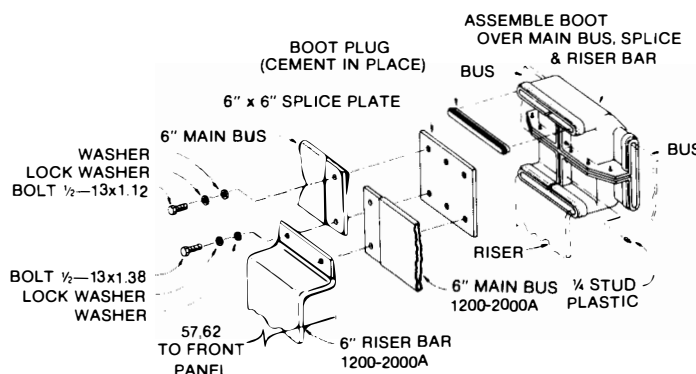
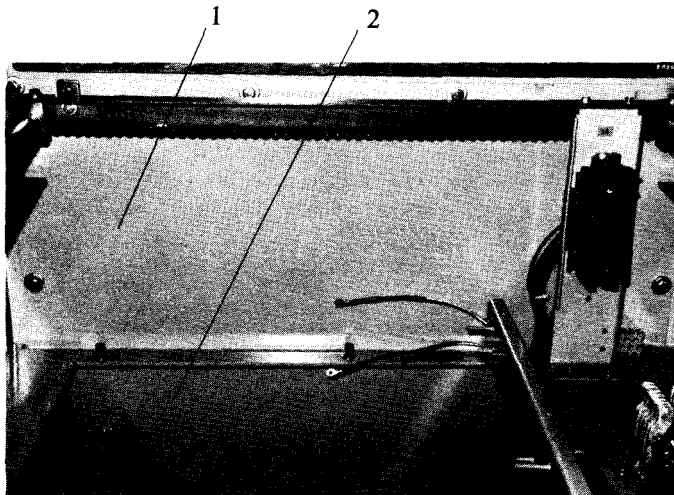

Fig. 20 Typical Shipping Splits

- (1) Unbolt and remove the inter-unit horizontal barriers from the vertical sections to be joined. Do not remove the small trays on which the position switch, auxiliary switch and ground shoe are mounted. See Fig. 45.
- (2) Unbolt and remove first the lower and then the upper unit bus cover from the vertical sections to be joined. The bus compartments to the two sections will now be exposed. It is not necessary to remove the secondary coupler or the racking mechanism chain in order to assemble the bus bars. See Fig. 21.



1. Vertical Bus Covers
2. Horizontal Inter-unit Barrier

Fig. 21 Bus Compartment Cover

- (3) Install the lower (phase 3) bus bar(s) from the right-hand section. If the main bus uses porcelain inserts, take extreme care not to chip the porcelain when installing the bus bars. Position the rubber bushings (furnished on the bus bars) in the middle of the porcelain through which they assemble. Bolt splice plates and bus bars together, following assembly instructions as given under CONNECTIONS. The sequence of parts from rear to front is: (1) splice plate with press nuts, (2) main bus bar (with spacers if 2 bar bus) (3) riser bars to breakers or roll-outs. Next, install the middle phase 2 bus bar(s) in the same fashion.
- (4) From the left-hand section install the upper (phase 1) bus bar(s) as described above.
- (5) Place the PVC bus-insulating boots, such as shown in Fig. 22, over the joints and secure with furnished nylon fasteners. Joint insulation is now complete.
- (6) Replace all barriers and cover plates previously removed.

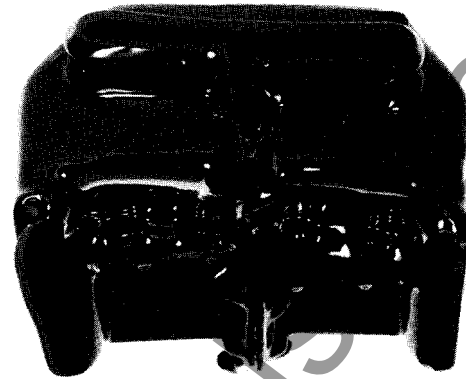

Fig. 22 Bus Insulating Boot

TAPED INSULATION INSTRUCTIONS FOR 5 & 15kV EQUIPMENT

The following insulation system involves the use of high-voltage insulating tape & electrical grade rubber-based putty*, 0282A3529, pts 4, 5 & 8. The high-voltage tape will be used both as a filler and also as the final insulation covering. Overlap any expired roll by 1/2 turn.

*NOTE: Electrical grade putty will be used only when required to grade voids and smooth out sharp edges of joints and pothead, terminator or entrance bushing connections.

SECTION 1: BUS BARS 5 & 15kV

Apply appropriate number of layers of high-voltage tape 0282A3529 pts 4 or 5 (2" or 4" wide), mastic side down, at a medium (Δ) tension to bus bars per Fig. 23 (5kV and 15kV).

NOTE: All bus bars are to be round edge type.

SECTION 2: TAPED JOINTS 5 or 15kV, Figs. 24, 25, 26, 27, 28, 29 and 30.

STEP (A) — FILLER 5 & 15kV

Apply three (3) layers — 1/2 lap of high-voltage tape 0282A3529 pts 4 or 5 (2" or 4" wide), mastic side down, at medium (Δ) tension over all bolt heads, nuts, bars and splice plates to form a smooth surface for taping (see* note above). Any bars with sharp burrs and edges must be deburred and smoothed before applying tape.

STEP (B) — OUTERWRAP 5 & 15kV

Apply two (2) layers, 1/2 lap of high-voltage tape 0282A3529 P-4 (2" wide), mastic side down, maintaining a medium (Δ) tension on the tape while wrapping. Begin the wrap away from the joints, overlapping the adjacent insulation, (epoxy fluid dip, thermoplastic sleeving, cable or tape) by three (3) inches minimum. Where potheads or porcelain bushings, etc., are to be wrapped, the tape must overlap the first porcelain skirt. When completing the wrapping of the joint, do not keep tension on the last 2" or 3" of tape. These last few inches should be laid in place without tension. This will prevent the tape end from lifting.

No other taping or paint is required.

NOTE: Medium tension thins a .030"x2" tape to approx. .024x1 3/4", and .030x4" thins to approx. .024x3 1/2".

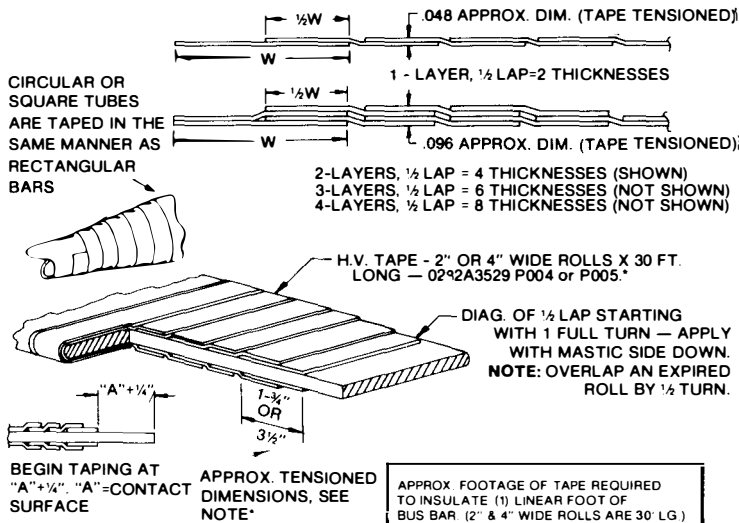

INSULATION RANGE	NUMBER OF LAYERS	TAPING METHOD	BAR SIZES							
			1/4 x 2	1/4 x 3	1/2 x 3	3/4 x 4	1/2 x 4	3/4 x 6	1/2 x 6	3/4 x 6
600 TO 5,000 V	1 LAYER	*	2"	4"	5"	6"	8"	9"	11"	12"
	1/2 LAP	+	4"	2'	3'	3'	4'	5'	5'	6'
5,001 TO 15,000V	2 LAYERS	*	2"	9"	11"	12"	18"	19"	23"	24"
	1/2 LAP	+	4"	5'	6'	6'	9'	10'	11'	12'

*NOTE: APPLY 3 LAYERS — 1/2 LAP FOR CONDUCTORS PASSING THROUGH C.T.'S
 *NOTE: APPLY TAPE AT MEDIUM TENSION TO PRODUCE A VOID-FREE, UNIFORM BUILD-UP OF TAPE. A MEDIUM TENSION THIN A .030" X 2" TAPE DOWN TO .024" X 1 1/4", and .030" X 4" DOWN TO .024" X 3 1/2". APPLY WITH MASTIC SIDE DOWN.

Fig. 23 Bus Bars

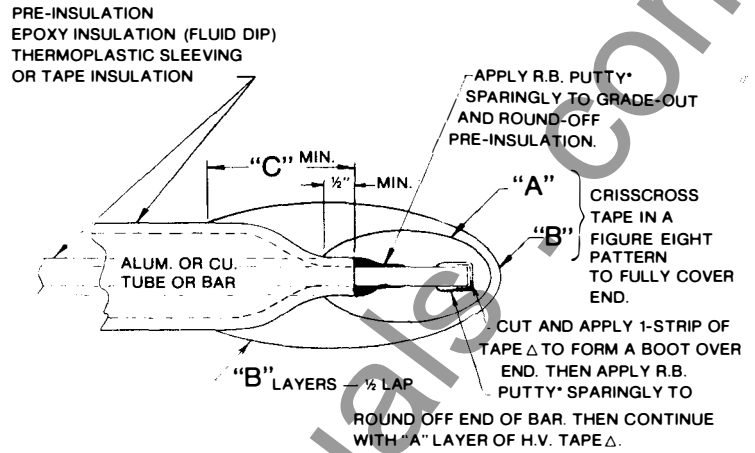

INSULATION LEVEL	INNER FILLER "A"	OUTER WRAP "B"	"C"	APPROX. NO. ROLLS PER JOINT OF H.V. TAPE Δ	
				2" OR 3" BARS OR TUBES	4" OR 6" BARS
5 OR 15KV	R.B. PUTTY* & 3-LAYERS TAPE	3-LAYERS TAPE Δ	3"	1/2 ROLL PUTTY* & 1/2 ROLL TAPE	1 ROLL PUTTY* & 1 ROLL TAPE

NOTES: * ELECTRICAL GRADE RUBBER-BASED PUTTY 0282A3529 P008 IN ROLL FORM WILL BE USED TO GRADE VOIDS AND SMOOTH OUT SHARP EDGES OF JOINTS. THIS PUTTY HAS NO INSULATION VALUE. 1-ROLL IS 1/2" X 1 1/2" X 5 FT. LG.
 Δ—HIGH VOLTAGE INSULATING TAPE 0282A3529 P004 ROLL IS .030" X 2" X 30' LG. APPLY WITH MASTIC SIDE DOWN.

Fig. 25 Dead End Bus Joint

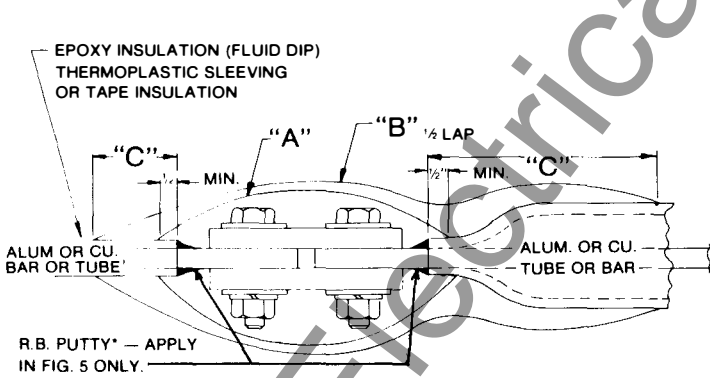

INSULATION LEVEL	INNER "A"	OUTER WRAP "B"	"C"	APPROX. NO. ROLLS PER JOINT OF H.V. TAPE Δ	
				2" OR 3" BARS	4" OR 6" BARS
5 OR 15 kV	3 LAYERS H.V. TAPE Δ	2 LAYERS H.V. TAPE Δ	3"	1 ROLL H.V. TAPE	2 ROLLS H.V. TAPE Δ

NOTES: * ELECTRICAL GRADE RUBBER-BASE PUTTY 0282A3529 P008 IN ROLL FORM WILL BE USED TO GRADE VOIDS AND SMOOTH OUT SHARP EDGES OF JOINTS. THIS PUTTY HAS NO INSULATION VALUE. 1 ROLL IS 1/2" X 1 1/2" X 5 FT. LG.
 Δ—HIGH VOLTAGE INSULATING TAPE 0282A3529 P004 — ROLL IS .030" X 2" X 30' LG. APPLY WITH MASTIC SIDE DOWN.

Fig. 24 Bus Connection Joint

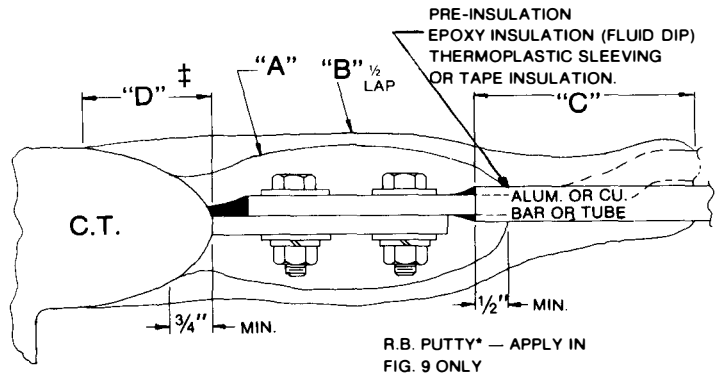

INSULATION LEVEL	INNER FILLER "A"	OUTER WRAP "B"	"C"	"D"	APPROX. NO. OF ROLLS PER JOINT OF H.V. TAPE Δ	
					2" OR 3" BARS OR TUBES	4" OR 6" BARS
5 OR 15 kV	3-LAYERS H.V. TAPE Δ	2-LAYERS H.V. TAPE Δ	3"	3" ‡	1/2 ROLL TAPE	1 1/2 ROLLS TAPE Δ

NOTES: *—ELECTRICAL GRADE RUBBER-BASED PUTTY 0282A3529 P008 IN ROLL FORM WILL BE USED TO GRADE VOIDS AND SMOOTH OUT SHARP EDGES OF JOINTS. THIS PUTTY HAS NO INSULATION VALUE. 1-ROLL IS 1/2" X 1 1/2" X 5 FT. LG.
 ‡—INSULATE AS FAR AS POSSIBLE — DO NOT COVER POLARITY MARKS.
 Δ—HIGH VOLTAGE INSULATING TAPE 0282A3529 P004 — ROLL IS .030" X 2" X 30' LG. — APPLY WITH MASTIC SIDE DOWN.

Fig. 26 Current Transformer Joint

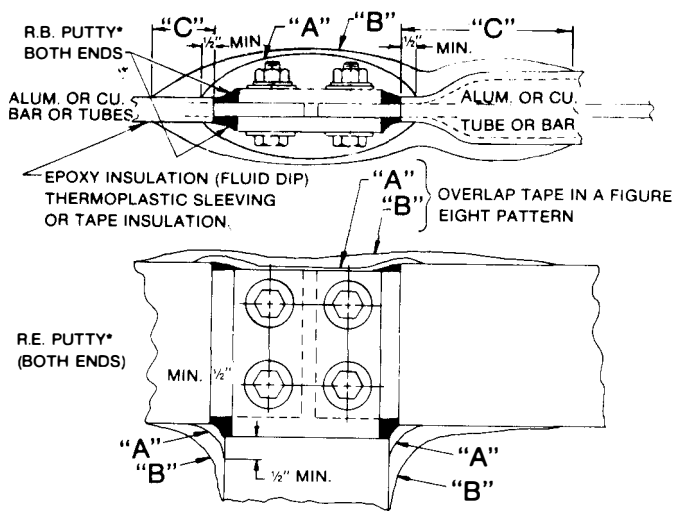

INSULATION LEVEL	INNER FILLER	APPROX. NO. OF ROLLS PER JOINT OF H.V. TAPE Δ			
		"A"	"B"	"C"	
5 OR 15 kV	R.B. PUTTY* & 3-LAYERS TAPE Δ	2-LAYERS TAPE Δ	3"	1/2 ROLL PUTTY* & 1 ROLL TAPE Δ	1 ROLL PUTTY* & 2 ROLLS TAPE Δ

NOTES: *—ELECTRICAL GRADE RUBBER-BASED PUTTY 0282A3529 P008 IN ROLL FORM WILL BE USED TO GRADE VOIDS AND SMOOTH OUT SHARP EDGES OF JOINTS. THIS PUTTY HAS NO INSULATION VALUE. 1-ROLL IS 1/2" x 1 1/2" x 5 FT. LG. Δ HIGH VOLTAGE INSULATING TAPE 0282A3529 P004 ROLL IS .030" x 2" x 30' LG. APPLY WITH MASTIC SIDE DOWN.

Fig. 27 Tee Connection Joint

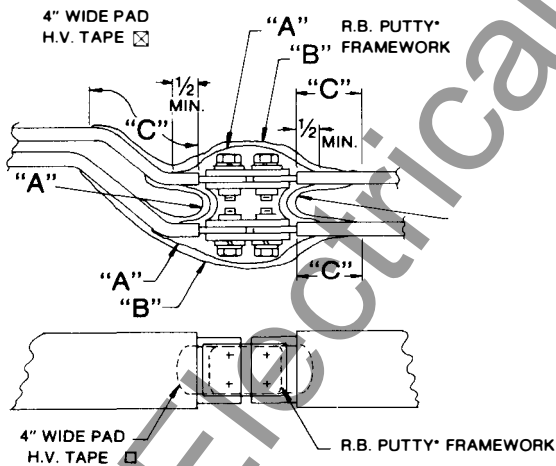

INSULATION LEVEL	INNER FILLER	APPROX. NO. OF ROLLS PER JOINT OF H.V. TAPE Δ			
		"A"	"B"	"C"	
5 OR 15 kV	R.B. PUTTY* & 3-LAYERS TAPE Δ	2-LAYERS TAPE Δ	3"	1/2 ROLL PUTTY* & 1 ROLL TAPE Δ	1 ROLL PUTTY* & 2 ROLLS TAPE Δ

NOTES: *—ELECTRICAL GRADE RUBBER-BASED PUTTY 0282A3529 P008 IN ROLL FORM WILL BE USED TO GRADE VOIDS AND SMOOTH OUT SHARP EDGES OF JOINTS. THIS PUTTY HAS NO INSULATION VALUE. 1-ROLL IS 1/2" x 1 1/2" x 5 FT. LG. Δ HIGH VOLTAGE INSULATING TAPE 0282A3529 P004 ROLL IS .030" x 2" x 30' LG. APPLY WITH MASTIC SIDE DOWN. \boxtimes H.V. TAPE 0282A3529 P005 — ROLL IS .030" x 4" x 30' LG.

Fig. 28 Double Bus Bar Joint

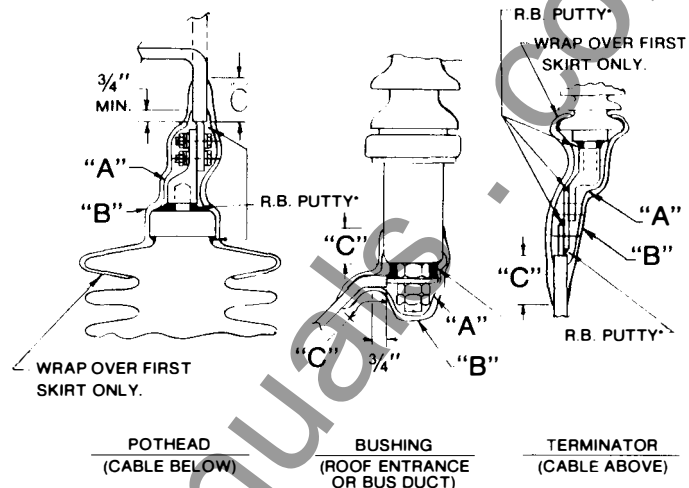

INSULATION LEVEL	INNER FILLER	APPROX. NO. OF ROLLS PER JOINT OF H.V. TAPE Δ			
		"A"	"B"	"C"	
5 OR 15 kV	R.B. PUTTY* & 3-LAYERS TAPE Δ	2-LAYERS TAPE Δ	3"	1/2 ROLL PUTTY* & 1 ROLL TAPE Δ	1 ROLL PUTTY* & 2 ROLLS TAPE Δ

NOTES: *—ELECTRICAL GRADE RUBBER-BASED PUTTY 0282A3529 P008 IN ROLL FORM WILL BE USED TO GRADE VOIDS AND SMOOTH OUT SHARP EDGES OF JOINTS. THIS PUTTY HAS NO INSULATION VALUE. 1-ROLL IS 1/2" x 1 1/2" x 5 FT. LG. Δ HIGH VOLTAGE INSULATING TAPE 0282A3529 P004 ROLL IS .030" x 2" x 30' LG. APPLY WITH MASTIC SIDE DOWN.

Fig. 29 Pothead or Bushing or Terminator

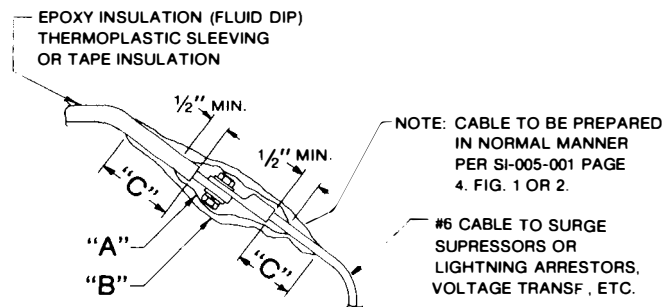

INSULATION LEVEL	INNER FILLER	APPROX. NO. OF ROLLS PER JOINT OF H.V. TAPE Δ			
		"A"	"B"	"C"	
5 OR 15 kV	R.B. PUTTY* & 3-LAYERS TAPE Δ	2-LAYERS TAPE Δ	3"	1/2 ROLL PUTTY* & 1 ROLL TAPE Δ	1 ROLL PUTTY* & 2 ROLLS TAPE Δ

NOTES: *—ELECTRICAL GRADE RUBBER-BASED PUTTY 0282A3529 P008 IN ROLL FORM WILL BE USED TO GRADE VOIDS AND SMOOTH OUT SHARP EDGES OF JOINTS. THIS PUTTY HAS NO INSULATION VALUE. 1-ROLL IS 1/2" x 1 1/2" x 5 FT. LG. Δ HIGH VOLTAGE INSULATING TAPE 0282A3529 P004 ROLL IS .030" x 2" x 30' LG. APPLY WITH MASTIC SIDE DOWN.

Fig. 30 #6 Cable Termination Joint

INSULATION MATERIALS FOR FIELD INSTALLATION — 5kV & 15kV MEDIUM VOLTAGE SWITCHGEAR

ORDERING INSTRUCTIONS															REVISIONS		
1. ORDER APPROPRIATE GROUP BASED ON TOTAL NUMBER OF JOINTS TO BE INSULATED. TO OBTAIN QUANTITIES NOT LISTED, ORDER A COMPOSITE OR MULTIPLE OF GROUPS.															2	1	
2. REFER TO DWG. 0144D2907 SHT. 1 FOR TYPICAL JOINTS AND RECOMMENDED METHODS OF INSULATING.																	
*NOTE: THE GROUPS LISTED PROVIDE TAPING MATERIALS FOR FIELD INSULATION OF BARE PRIMARY CONDUCTOR JOINTS. QUANTITIES SHOWN ARE FOR AVERAGE JOINTS BASED ON 2" - 3" or 4" - 6". CONDUCTORS, SLICES, TERMINATIONS, ETC.															Revised Quan. of P001 J. Rule 7-11-83 Removed Vend. Design J. Rule 3-11-81		
5kV CONDUCTOR JOINTS																	
2" or 3" WIDE BARS*							4" or 6" WIDE BARS*										
NO. OF JOINTS	1	2	3	6	9	12	15	1	2	3	6	9	12	15	Pt.	MATERIAL IDENTITY	MATERIAL DESCRIPTION
GRP. NO. †	1	2	3	4	5	6	7	8	9	10	11	12	13	14	No.		
NO. OF ROLLS	1	1	2	4	6	8	10	1	2	3	6	9	12	15	001	0282A3529P008	Elec. Grade Putty Tape ½" x 1½" x 5'
	1	1	2	4	6	8	10	1	2	3	6	9	12	15	002	0282A3529P004	H.V. Insul. Tape .030" x 2" x 30'
15kV CONDUCTOR JOINTS																	
2" or 3" WIDE BARS*							4" or 6" WIDE BARS*										
NO. OF JOINTS	1	2	3	6	9	12	15	1	2	3	6	9	12	15	Pt.	MATERIAL IDENTITY	MATERIAL DESCRIPTION
GRP. NO. †	15	16	17	18	19	20	21	22	23	24	25	26	27	28	No.		
NO. OF ROLLS	1	1	1	1	2	2	3	1	1	1	2	3	4	5	001	0282A3529P008	Elec. Grade Putty Tape ½" x 1½" x 5'
	1	1	2	4	6	8	10	2	4	6	12	18	24	30	002	0282A3529P004	H.V. Insul. Tape .030" x 2" x 30'

BUS DUCT

Fig. 31

Bus ducts connecting between groups of metal-clad switchgear, or between metal-clad switchgear and other apparatus, should be installed as shown on the arrangement drawings furnished with the ducts. Supports should be provided as indicated on the drawings.

All joints in the bus, including adjustable joints, should be assembled and insulated as described above for main buses. Adjustable joints are provided in long runs of bus duct to allow for variations in building construction, etc. These joints should be loosened before installation of the duct, then tightened after being set in the position required by the fixed points at the ends of the duct.

Outdoor bus ducts must be gasketed at the joints between shipping sections. Coat both sides of the flat gasket and the flanges of both duct sections with Sterling U310 varnish before assembly. Bolt the two duct sections together. Remove the top cover from one duct section and place 3/8 inch elastic compound bead along top of joint, slightly overlapping the sides. Bolt top cover in place and fasten roof cap in place over the joint. See Fig. 32. When top covers are removed after installation for inspection, the 3/8 inch elastic compound bead must be replaced to insure a tight seal.

Removable front and rear covers of vertical sections of bus duct must also be gasketed. Coat both sides of the gasket, the flange of the duct, and the edges of the inside surface of the cover with Sterling U310 varnish before as-

sembly. Do not bolt these covers in place until all interior assembly work on the duct is completed and access will no longer be required.

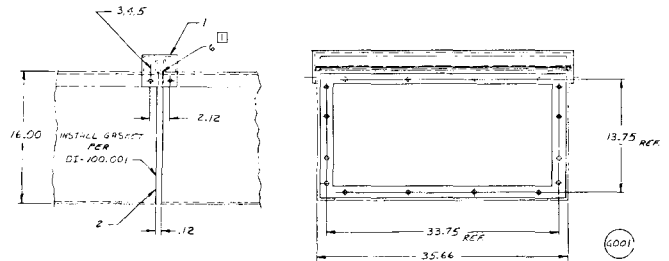

Fig. 32 Bus Duct Gasket

Outdoor bus ducts of the 13.8 kV class are provided with heaters. Connect these heaters in accordance with the wiring diagrams furnished with the equipment before energizing the bus duct.

PRIMARY CABLES

The primary cable connections are reached by removing the rear bolted covers.

When circuit breakers are stacked two-high and primary cable terminations must be made in both upper and lower units, the procedure described below should be followed. (Refer to Fig. 33.)

Fig. 32 (0121A6285 Rev. 4)

1. Remove rear bolted covers.
2. Remove batten (1), Fig. 33.

Fig. 33 (0282A3015)

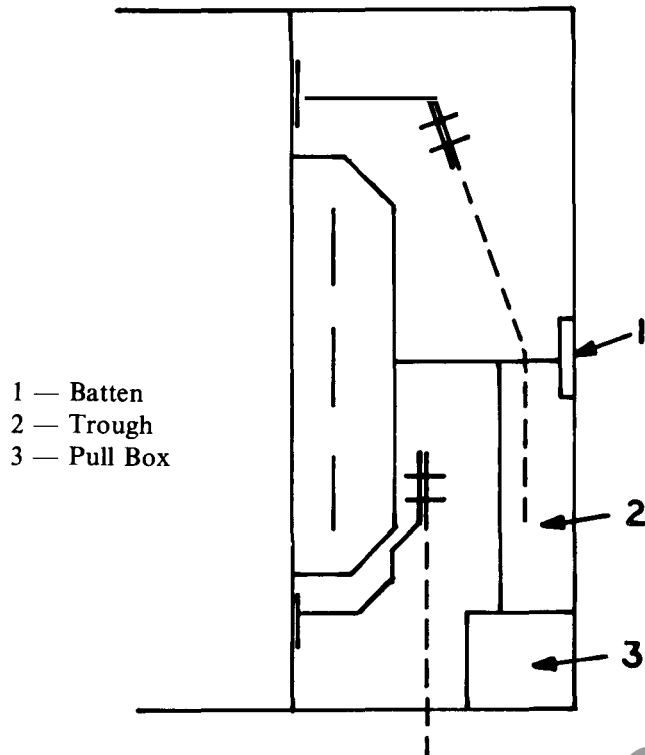

Fig. 33 Installation of Primary Cables

3. Remove cable trough cover and pull-box cover.
4. Remove cable trough (2), Fig. 33.
5. If primary cables enter switchgear from below, terminate cables for lower unit first. If primary cables enter from above, terminate cables for upper unit first.
6. Replace cable trough.
7. Terminate primary cables in remaining unit. (Pulling cables thru cable trough.)
8. Replace pull-box cover, cable trough cover, batten and rear bolted covers.

Before any primary cable connections are made, the cables should be identified to indicate their phase relationship with the switchgear connections. This is necessary to assure that motors will rotate in the proper direction and that the phase rotation is the same when interconnecting two different sources of power.

There are two common methods of making primary cable connections:

(a) Potheads

Potheads are used when it is desired to hermetically seal the end of the cable to make a moisture-proof

connection between the cable and switchgear bus. A pothead also prevents seeping of oil from the end of oil-impregnated varnish cambric or paper insulated cable.

(b) Clamp-type terminals and stress cones.

No insulation materials are furnished for cable terminations. When potheads are supplied as part of switchgear, insulation materials are furnished for the bar terminations to the pothead studs.

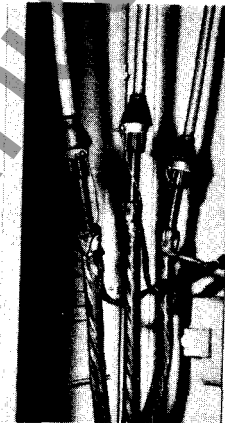

Fig. 34 (8918431C)

Fig. 34 Cable Termination without Pothead, Single Conductor

In all cases, carefully follow the cable manufacturer's recommendations for installation of the type of cable being used. A typical example of terminating a shielded cable is shown in Fig. 34. If the cable is aluminum, the conductor surface must be carefully abraded and the cable covered liberally with a joint compound recommended by the cable manufacturer.

INSULATING PRIMARY CABLE TERMINATIONS

All field-assembled joints for primary cable terminations should be prepared as outlined under CONNECTIONS. Upon completion of the cable termination, care must be exercised when taping the exposed joint.

1. Check to see that a sufficient area of insulating tape extends beyond the insulation furnished on the terminal bars (2 inches for 5 kV, 3 inches for 15 kV). Refer to Fig. 23.
2. All terminations should be insulated as outlined in table, Fig. 23, for correct layers of insulation.
3. The instructions for application of the tape insulation is the same as outlined for TAPED JOINTS.

POTHEADS

Installation procedures for a three-conductor lead-sheathed cable with a wiping sleeve cable entrance fitting on the pothead are outlined in Russgreen Cat. No. P66. This is the type most generally used. The factory does not furnish insulating materials for completing stress cones and cable terminations. In all cases, carefully follow the cable manufacturer's recommendation for installation of the type cable being used.

TERMINATION WITHOUT POTHEAD

The factory does not furnish insulating materials for completing the termination of primary cables, nor does it furnish stress cone material. The cable manufacturer's recommendations should be followed for the type of cable being used.

When stress cones are required, packaged stress cone kits such as the GE Termi-Matic[®] Cable Termination System are frequently used. Information and ordering data can be found in GEA-1017. Since the termination is inside the metal-clad enclosure, the Indoor Type A system is generally applicable. If excessive contamination is a problem, the padmount type G system may be desirable. No matter which system is used, step-by-step pictorial instructions will be furnished as part of the kit.

The space provided for primary cable terminations in the standard Power-Vac arrangements is more than sufficient for the Termi-Matic[®] system. Hand-taped stress cones require more space. However, the cable termination space provided in Power/Vac* is never less than the minimum recommended for a hand-taped stress cone.

In making up stress cone terminations, ground clamps and ground leads are installed. Care must be taken to assure that these grounded elements are installed such that the required clearance to energized parts is maintained. For insulated bars or unshielded cables, these are

For 5kV equipments — at least 2 inches
For 15kV equipments — at least 3 inches

When terminating three conductor cables which flare out to single conductor terminations, the crotch at the root of the flare-out should be adequately sealed to prevent possible entrance of moisture into the three conductor jackets.

For long cable runs within the equipment, a support to restrain lateral movement of the cables under short circuit conditions will be provided approximately 20 inches from the termination point. The customer's incoming cables should be lashed securely to this support.

There is no provision in the Power/Vac* equipment to support the weight of primary cables.

GROUND FAULT CURRENT TRANSFORMERS (THROUGH-TYPE)

Through-type current transformers (see Fig. 35) are furnished where specified for sensitive protection against ground faults. These transformers are normally installed in a horizontal position directly above or below the primary cable terminals so that the primary cable or cables can pass through them. One transformer is required for each three-phase circuit.

Where armored cable is used, the armor must be terminated and grounded before the cable passes through the transformer. Armor clamps are furnished for this purpose when specified.

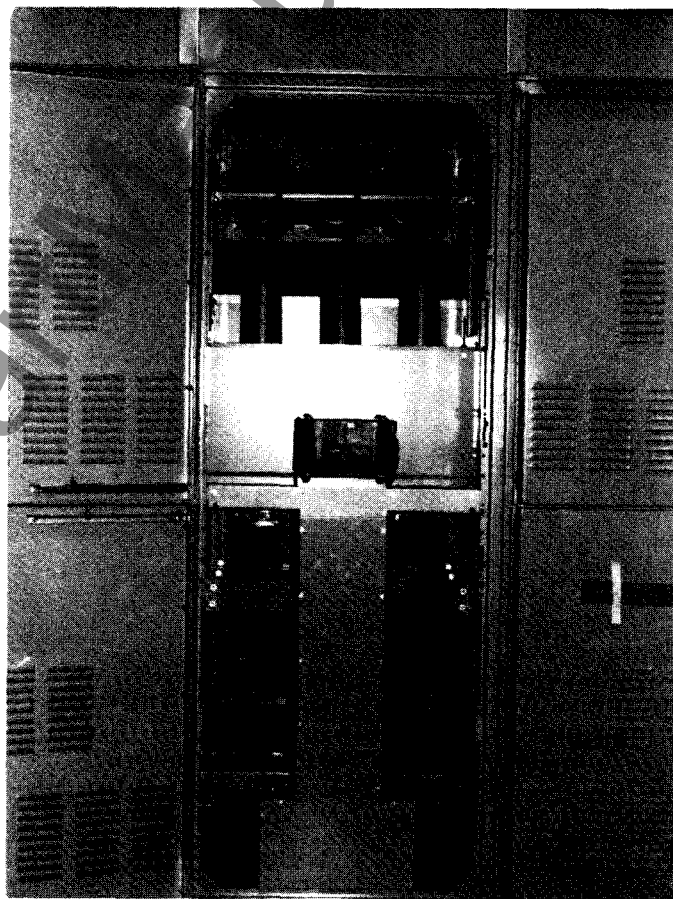

Fig. 35 (8043127)

Fig. 35 Rear View of Unit Showing
Through-Type Ground Fault Current Transformers

When lead or other conducting sheath cable, or cable with shielding tape or braid is used, it is recommended that the sheath or shield be grounded solidly to the switchgear ground bus. The ground lead should be bonded to the sheath or shield on the side of the current transformer away from the primary terminals. In cases where the ground cannot be applied before the cable passes through the transformer, bond the lead to the sheath or shield between the transformer and the primary terminals. The ground conductor must then be passed back along the cable path through the current transformer before being connected to the ground bus.

Where potheads are used in units provided with ground fault current transformers, the pothead mountings must be insulated from ground.

CONTROL CABLES

When control cables enter the unit from below, the conduit should not extend more than one inch above the floor. The control cables may be pulled through the conduits before or after the switchgear is installed, whichever is more convenient.

Control cables should be guided toward the side sheet and run behind the track assembly as shown in Fig. 36. This will prevent the circuit breaker or roll-out carriage from interfering.

Connect the cables to the terminal blocks in accordance with the wiring diagrams furnished for the requisition.

The cables from the control power source to the switchgear should be large enough to avoid excessive voltage drop when the circuit breakers are operated. See testing instructions.

Where units have been split for shipment, any control or other secondary leads which must connect across the split will be arranged with terminal blocks at the top or on the side sheet so that the wires can be reconnected. The wires will be cut to length and formed before being folded back so that a minimum of time will be required for reconnecting them.

GROUND BUS

Where the equipment is shipped in more than one section, the ground bus must be connected by using the splice plates furnished with the equipment. Assemble the ground bus joints as outlined under CONNECTIONS.

The ground bus is bolted to the rear of the frame near the bottom. It is arranged so that connections to the station ground can be made in any vertical section. Ground bus risers are provided in each cable compartment to provide a convenient place to ground cable armor, cable sheath, shields or ground wires. The switchgear ground bus must be connected to the station ground bus by a conductor having a

current-carrying capacity equal to that of the switchgear ground bus. It is very important that the equipment be properly grounded to protect the operator from injury when short circuits or other abnormal occurrences take place, and to ensure that all parts of the equipment, other than live parts, are at ground potential.

LIGHTNING PROTECTION

It will be the responsibility of the purchaser to specify suitable surge arresters to protect the switchgear from damage due to lightning. The General Electric Company's recommendations as to the types of circuits requiring protection, and a list of recommended surge arresters, are contained in Bulletin GET -6460, copies of which are available upon request.

When surge arresters are furnished, the primary cable terminal will be insulated at the factory unless it must be disconnected for shipment. When this connection is completed in the field it will be necessary to insulate the primary connection before the switchgear is energized.

SURGE SUPPRESSORS

General Electric surge suppressors are provided on each feeder circuit. These are self-contained units which require no maintenance.

ROOF ENTRANCE BUSHING

When assembling the connection bare end of roof entrance bushing inside the switchgear and other terminations where porcelain insulators are used, insulation should be applied as shown in TAPE INSULATION INSTRUCTIONS FOR 5 & 15 kV.

TESTING AND INSPECTION

After the equipment has been installed and all connections made, it should be tested and inspected before putting it in service. Although the equipment and devices have been completely tested at the factory, a final field test should be made to be sure that the equipment has been properly installed and that all connections are correct and have not become loose in transportation. The primary equipment should be completely de-energized while the tests are in progress.

Directions for testing devices such as relays, instruments and meters are given in the instruction book furnished for each device. The settings of the protective relays must be coordinated with the other relays on the system and therefore these relays must be set by the purchaser. General instructions on setting the relays are given in the relay instruction books. Special instruction books are furnished for complicated automatic equipment, describing the sequence of operation of the devices required to perform the desired function.

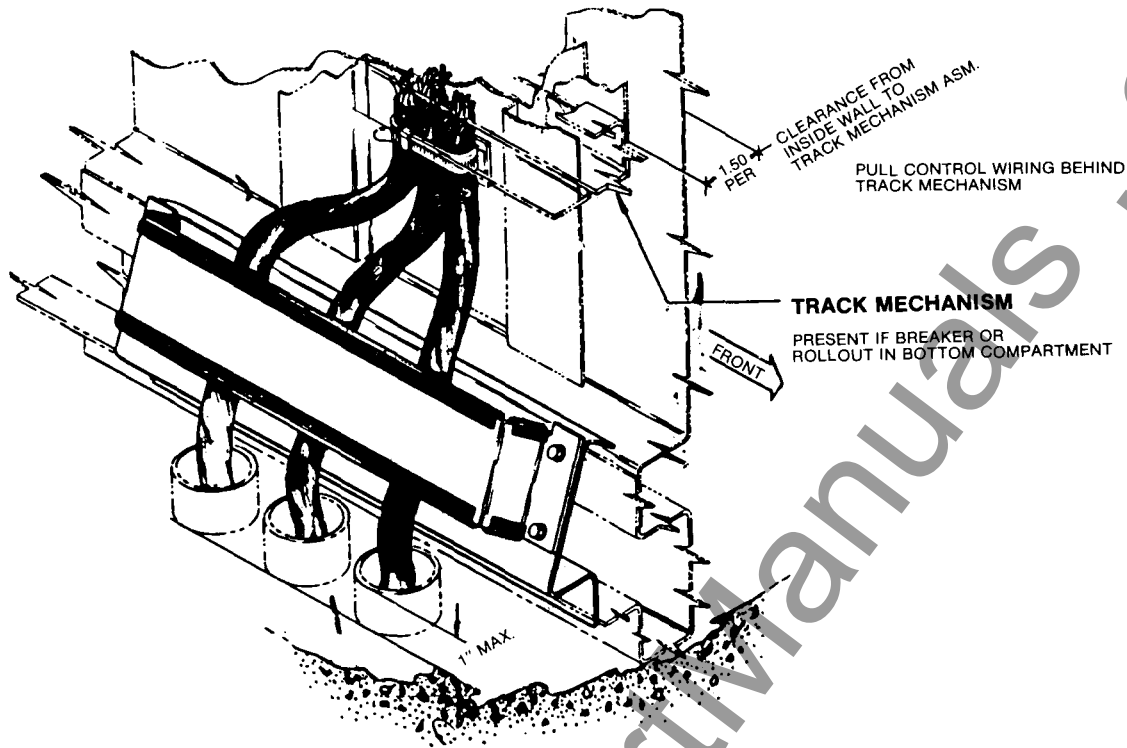

Fig. 36 Control Cable Guide

When transformers are furnished to supply the control power, the primary taps should be selected so that the control voltage indicated on the wiring diagram is obtained on the secondary of the transformer. When a battery is used to supply the control power, the cables from the battery to the switchgear should be large enough to avoid excessive voltage drop. The voltage at the terminals of the breaker closing coils, when the breaker is being closed, should not be less than 112.5 volts for 125-volt coils and 225 volts for 250-volt coils.

The operation of the breaker with its associated devices may be tested in the unit while the equipment control power is energized by racking the breaker into the test position and engaging the secondary coupler. This is accomplished by lowering the handle on the right-hand side of the breaker mechanism and pushing forward until the coupler engages.

High-potential tests to check the integrity of the insulation are not necessary if the insulation instructions in this book are carefully followed. Should the purchaser desire to make high-potential tests, the "test voltage" should not exceed 14 kV alternating current for 4.16 kV and 27 kV alternating current for 13.8 kV equipment. These voltages are 75 percent of factory test voltages and are in accordance with ANSI standards.

Voltage transformers, control power transformers, surge arresters and surge suppressors must be disconnected during high potential testing. When bus ground studs and caps are

furnished, the caps are removed in order to attach grounding cables. The purchaser must replace the ground stud caps after testing and/or maintenance is complete.

OPERATION

The metal-clad switchgear provides safe operation and easy removal and replacement of the circuit breaker. Circuit breakers of the same type, rating and duplicate wiring may be interchanged. Various interlocks are provided between the metal-clad and breaker to insure safe operation. The following instructions explain how these interlocks should function. If the breaker and metal-clad do not function in the manner called for in these instructions, do not force, modify, adjust or remove any interlocks. Consult your local General Electric Company Apparatus and Service Engineering office for instructions. Failure to adhere to the following instructions could result in serious injury.

BREAKER INSTALLATION AND REMOVAL

With all primary and control power circuits de-energized and before installing the breaker, clean the mating surfaces of the metal-clad and circuit breaker primary disconnects, secondary disconnects and ground shoe, and apply a thin coating of 0282A2048 P009 contact grease. This will prevent galling of the silvered contact surfaces.

Check the racking mechanism to make certain that it is in the disconnect position, see Fig. 37. The tape indicator

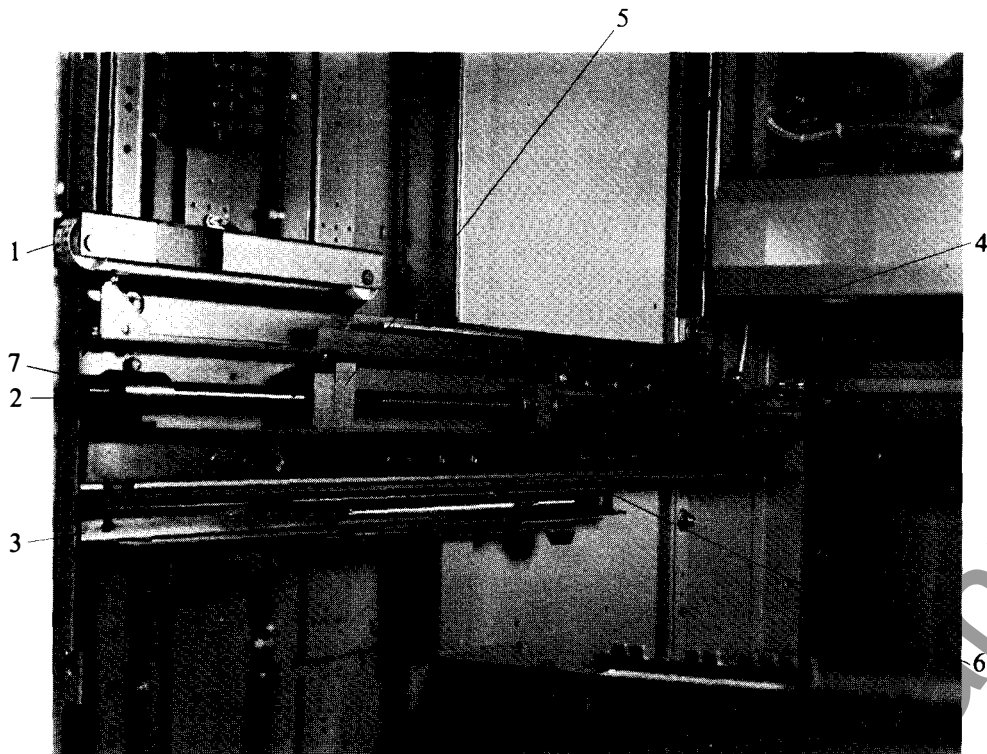

- 1 — Racking Position Indicator
- 2 — Racking Shaft
- 3 — Rail
- 4 — Shaft Bearing
- 5 — Racking Nut
- 6 — Jack Screw
- 7 — Interlock

Fig. 37 Racking Mechanism



- 1 — Lift Truck Brace
- 2 — Wheel Locking Plate
- 3 — Truck Locking Bar Handle
- 4 — Safety Latch Handle

Fig. 38 Lift Truck Connection to Rails

should read "Disc/Test" and the drive nuts on the jack screws should be in the forward position against their respective stops. The racking mechanism is accurately leveled and checked at the factory and should need no adjustment.

Check the circuit breaker to ensure that it is in the "OPEN" and "DISCHARGED" position.

Attach the lift truck to the equipment, after it has been prepared for docking, by adjusting the height of the carriage until the docking hooks at the ends of the arms are slightly higher than the rail surface in the equipment. When this is done, position the hooks over the slots in the rails, and lower them into the slots (See Fig. 38 for parts 1-4). Depress both track roller blocking interlocks (2) slightly and extend the docking interlock bars (1). They will pass under the equipment rails and lock the lift truck arms to the rails. Do this on both sides. The track roller blocking interlocks are now in the raised position and are thus no longer blocking the track rollers. The lift truck arms should be approximately level. The breaker can now be rolled onto or off the lift truck.

To load the breaker onto the lift truck, extend each docking interlock bar (1) by slightly depressing the track roller blocking interlock (2) and then moving the handle (3) away from the mast as far as it will go toward the end of the arms. This permits the track roller blocking interlocks to be in their raised position. The height of the arms should be adjusted to engage the track rollers on the sides of the breaker. Depress each track roller blocking interlock (2) fully, and return each docking interlock bar to its retracted position by means of handle (3). The breaker is now blocked in position on the lift truck.

Remove the breaker from the equipment by releasing and rolling it fully onto the lift truck rails until it touches the stop on the rails. Depress both track roller blocking interlocks (2) fully and then move handles (3) as far as they can go toward the mast. Release the track roller blocking interlocks. Raise the carriage slightly to release the docking hooks from the slots in the equipment rail; move the load a short distance from the equipment, and lower it to just above floor level before transporting it away from the area.

To remove the lift truck and set the breaker on the floor, lower the carriage until the breaker is resting on the floor and the load of the track rollers is no longer being supported by the lift truck arms. Depress the track roller blocking interlocks (2) slightly and move handles (3) as far as they can go away from the mast. Do this on both sides. The track roller blocking interlocks (2) are now in their raised position. The lift truck can now be pulled away from the breaker, but the truck safety latch must be held in the released position by moving the handle (4) located on the right arm, away from the mast. This permits the track rollers to pass under the latch.

Lift the breaker for insertion into the equipment as follows. After the breaker has been loaded onto the lift truck and before raising it from the floor, check to make sure that

the track roller blocking interlocks (2) are in their depressed position and that the docking interlock bars (1) are retracted by moving handles (3) towards the masts. Raise the load by turning the winch handle clockwise. If the cable has been slack, guide it so that it winds evenly on the drum until it starts to tighten under load. As the load is lifted, there will be clicking noise due to the winch pawl. If the noise stops, maintain grip on the handle and lower the load to the floor. Investigate why the pawl is not engaging and make repairs before attempting to lift the load any further. Raise the load to the required height and proceed as instructed earlier in attaching the lift truck to the equipment.

To move the breaker from the lift truck into the equipment, the safety latch must be held in the released position by moving the handle (4) located on the right arm, away from the mast. When moving the breaker onto the lift truck the track rollers will lift this latch, making it unnecessary to operate the handle. The purpose of the safety latch is to provide an automatic means of retaining the breaker on the truck if the track roller blocking interlock has not been operated to its blocking position before lifting the breaker from the ground (See GEK-90214).

After the safety catch on the right-hand rail has been disengaged, the breaker can now be rolled forward onto the lift truck for transporting.

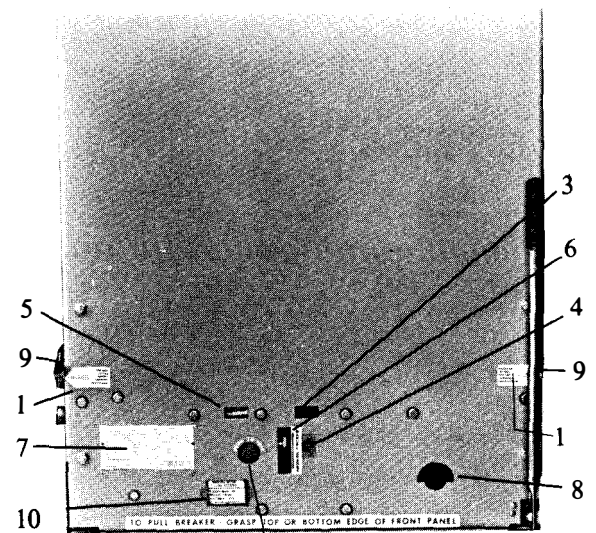

VBI Breaker

- | | |
|--------------------------|------------------------------|
| 1 — Indicator | 6 — Manual Charge |
| 2 — Push to Trip Open | 7 — Nameplate |
| 3 — Open-Close Indicator | 8 — Manual Close |
| 4 — Counter | 9 — Breaker Racking Arm |
| 5 — Charge Indicator | 10 — Close Spring Gag Access |

Fig. 39 Racking Arm Position Indicator Lever

After the breaker has been racked fully into the connected position and then is removed from the unit, the engagement and alignment of the primary disconnect fingers on the breaker studs may be checked with respect to the stationary conductor in the unit. (THE SWITCHGEAR MUST BE DE-ENERGIZED FOR THIS CHECK.)

Use the racking handle to turn the jackscrew several turns toward the connected position, until the shutters are opened to uncover the opening to the insulation tube and stationary conductor in the unit. Inspect the impression made in the coating of contact lubricant 0282A2048P009 in the stationary conductor surface by the breaker primary disconnect fingers.

On 1200 and 2000 ampere ratings, there must be heavy impressions of all the fingers on both the top and bottom of the stationary conductor bar. The impression should extend back from the front end of the bar a minimum of 1/2 inch and should be no closer than 3/16 inch to either side of the bar.

On 3000 ampere ratings, there must be heavy impressions of all the fingers on the cylindrical conductor. The impressions should extend back from the front end a minimum of 1/2 inch.

IF THE CONTACT WIPE IS NOT PROPER, DO NOT MAKE ANY ADJUSTMENT. COMMUNICATE WITH THE NEAREST GENERAL ELECTRIC COMPANY APPARATUS AND SERVICE ENGINEERING OFFICE FOR INSTRUCTIONS.

BREAKER RACKING WITH FRONT DOOR CLOSED

The circuit breaker can be racked in and out of the "Connect" position with the front door of the metal-clad closed. For maximum safety the breaker must always be racked with the front door closed when primary power is connected to the metal-clad. Make sure the breaker is open before attempting to rack the breaker. The breaker is installed in the metal-clad unit as described in BREAKER INSTALLATION. Engage the racking arms and then close the front door of the unit and secure it. Insert the racking handle into the hole in the left side of the front door and engage the racking mechanism by pushing it in fully. Rack the breaker by rotating the handle clockwise (60 turns are required) until a positive stop is felt. The breaker is now in the fully connected position and the tape indicator should read "Conn".

DO NOT EXCEED 60 FT. LBS. TORQUE.

To rack the circuit breaker from the "Connected" to the "Disconnect/ Test" position be sure that the breaker is open then turn the handle counterclockwise.

REMOTE RACKING ATTACHMENT

The breaker can be racked between the "Disconnect/ Test" and "Connected" positions electrically using the remote racking device. See DESCRIPTION — REMOTE RACKING ATTACHMENT.

POSITIVE INTERLOCK

The positive interlock functions to prevent racking a breaker between the "Connect" and "Disconnect/Test" positions except when the primary contacts are open.

The positive interlock consists of a bar which protrudes from the left side of a closed breaker to engage a slot in the left-side racking mechanism when the breaker is in either the "Disconnect/Test" or "Connected" position. When the interlock is engaged the racking mechanism cannot be operated (See Fig. 40.)

To test the function of the positive interlock install a circuit breaker following the instructions given under BREAKER INSTALLATION. For the test the control power circuits in the metal-clad must be energized.

Place the breaker in the "Disconnect/Test" position and connect the secondary disconnect device by pulling down on the breaker handle and horizontally inserting the lever arm fully into the breaker to engage the secondary disconnects. This will actuate the spring-charging motor and charge the breaker-closing springs. BEFORE PROCEEDING WITH THIS CHECK, IT IS NECESSARY THAT THE PRIMARY CIRCUITS BE DE-ENERGIZED. Close the breaker with the control switch on the front of the door then attempt to insert the racking handle into the hole in the unit door. A definite stop should be encountered, preventing the socket on the racking handle from engaging the racking mechanism.

Trip the breaker and rack it into the connected position. THE PRIMARY CIRCUITS MUST BE DE-ENERGIZED BEFORE MAKING THIS CHECK OF THE POSITIVE INTERLOCK. Close the breaker and attempt to insert the racking handle into the hole in the unit door. A definite stop should be encountered, preventing the socket on the racking handle from engaging the racking mechanism.

If the interlock does not function as indicated in either of the above cases DO NOT MAKE ANY ADJUSTMENT. COMMUNICATE WITH THE NEAREST GENERAL ELECTRIC COMPANY APPARATUS AND SERVICE ENGINEERING OFFICE FOR INSTRUCTIONS.

NEGATIVE INTERLOCK

The negative interlock functions to hold the breaker in a mechanical and electrical trip-free mode when it is being racked between the "Disconnect/ Test" and "Connect" positions. As an added precaution, the negative interlock will trip the breaker and hold it trip-free if an attempt is made to

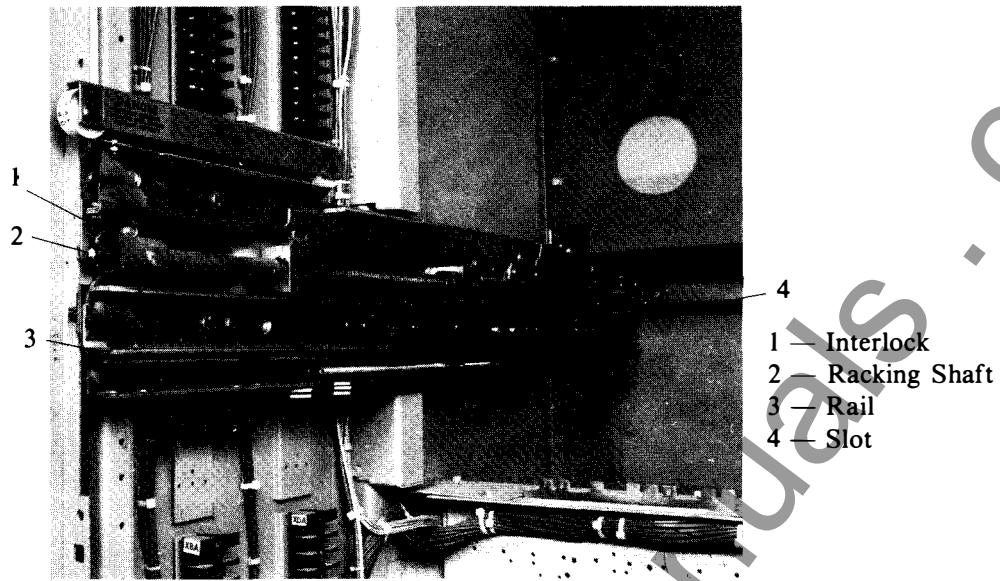

Fig. 40 Positive Interlock

Fig. 40 (8918438D-1)

operate the racking mechanism when the breaker is closed and in either the “Disconnect/Test” or “Connect” position, and the positive interlock fails to function.

The negative interlock consists of two notched members in the left-side track assembly which operate the negative (trip latch) interlock roller on the left side of the breaker. Refer to Fig. 41. On the metal-clad, one member is stationary and the other is a spring-loaded slide attached to the racking mechanism. A third member, a notched sliding link, provides the key lock functions and is described under KEY LOCKS. See Fig. 42.

To test the function of the negative interlock, install a circuit breaker following the instructions given under BREAKER INSTALLATION. For this test the control power circuits in the metal-clad must be energized.

Place the breaker in the “Disconnect/Test” position and connect the secondary disconnect device by pulling down on the breaker handle and inserting the level arm fully into the breaker. This will actuate the spring-charging motor and charge the breaker-closing springs. Push the sliding link located on the front of the left track to the rear. Refer to Fig. 42. This will cause the negative interlock roller on the breaker to depress and keep the breaker in the trip-free mode. Leave the sliding link in the rear position and attempt to close the breaker using the control switch. Nothing should happen. Now attempt to close the breaker by depressing the manual close button. The closing springs will discharge but the breaker should remain open. Return the sliding link to the forward position.

Rack the circuit breaker into the connected position and close it either manually or electrically. With the sliding link in the rear position, attempt to close the breaker using the control switch. Again, nothing should happen. Now attempt to close the breaker by depressing the manual close

button. Again, the closing springs will discharge but the breaker should remain open.

If the interlock does not function as indicated in either of the above cases DO NOT MAKE ANY ADJUSTMENT. COMMUNICATE WITH THE NEAREST GENERAL ELECTRIC COMPANY APPARATUS AND SERVICE ENGINEERING OFFICE FOR ADDITIONAL INSTRUCTIONS.

SPRING DISCHARGE INTERLOCK

The spring discharge interlock consists of a notched member in the right-side track assembly which activates the spring discharge roller on the right side of the breaker. Refer to Fig. 43.

The function of the spring discharge interlock is to prevent the breaker-closing spring from being charged unless the breaker is in the “Connect” or “Disconnect/Test” position or removed from the cubicle. In addition, it will mechanically discharge the breaker springs when the breaker is moved between any of the above mentioned positions and prevent recharging by opening the close-latch-monitoring switch in the breaker spring-charging circuit.

To test the function of the spring-discharge interlock, install a circuit breaker following the instructions given under BREAKER INSTALLATION. For this test the control power circuits in the metal-clad must be energized.

Place the breaker in the “Disconnect/Test” position and connect the secondary disconnect device by pulling down on the breaker handle and inserting the level arm fully in the breaker. This will actuate the spring-charging motor and charge the breaker-closing springs.

Rack the breaker toward the connected position using the manual racking handle. The spring-discharge interlock should discharge the breaker springs in three to five turns.

Fig. 41 (8918431F)

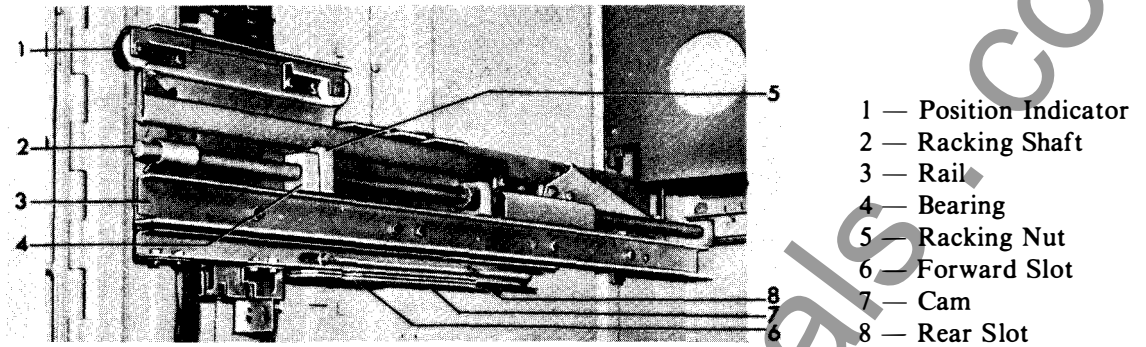

Fig. 41 Negative Interlock

Fig. 42 (8918438D-2)

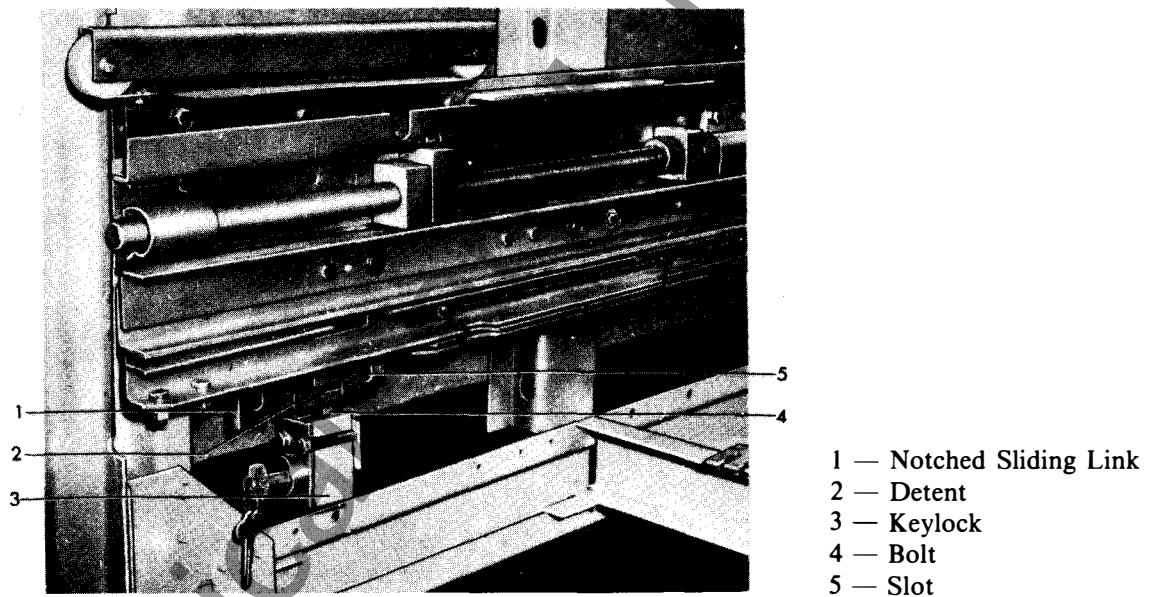

Fig. 42 Key Lock and Padlocks

Continue to rack the breaker to the connected position. Just before reaching the connected position, the spring charging motor will be re-energized to charge the closing spring. Close the breaker. Attempt to install the racking crank. This should not be possible because it should be blocked by the positive interlock. Trip the breaker. Rack the breaker toward the disconnected position. The spring-discharge interlock should discharge the breaker closing springs in 3 to 5 turns. Continue to rack the breaker to the disconnected position. Re-energize the secondary disconnect device as before to cause the spring-charging motor to charge the breaker closing springs. Raise the racking arms to the release position and roll the breaker forward. The spring-discharge interlock should discharge the breaker closing springs before traveling 1/2 inch.

If the interlock does not function as indicated DO NOT MAKE ANY ADJUSTMENT. COMMUNICATE WITH THE NEAREST GENERAL ELECTRIC COMPANY APPARATUS AND SERVICE ENGINEERING OFFICE FOR INSTRUCTIONS.

INTERFERENCE INTERLOCK

The function of the mechanical interference interlock is to permit only breakers with the same ratings to be inserted in any specific compartment.

This interlock consists of two mated comb-like plates, one on the equipment and one on the breaker. The equipment interference plate is permanently fastened to a cross member located just below the breaker mechanism frame device panel. (See Fig. 44)

TO PREVENT DAMAGE DO NOT REMOVE, REPLACE OR READJUST THE RATING INTERFERENCE PLATES ON EITHER THE METAL-CLAD UNIT OR THE POWER VAC* CIRCUIT BREAKER. IN CASE OF A PROBLEM CONSULT YOUR NEAREST GENERAL ELECTRIC COMPANY APPARATUS AND SERVICE ENGINEERING OFFICE.

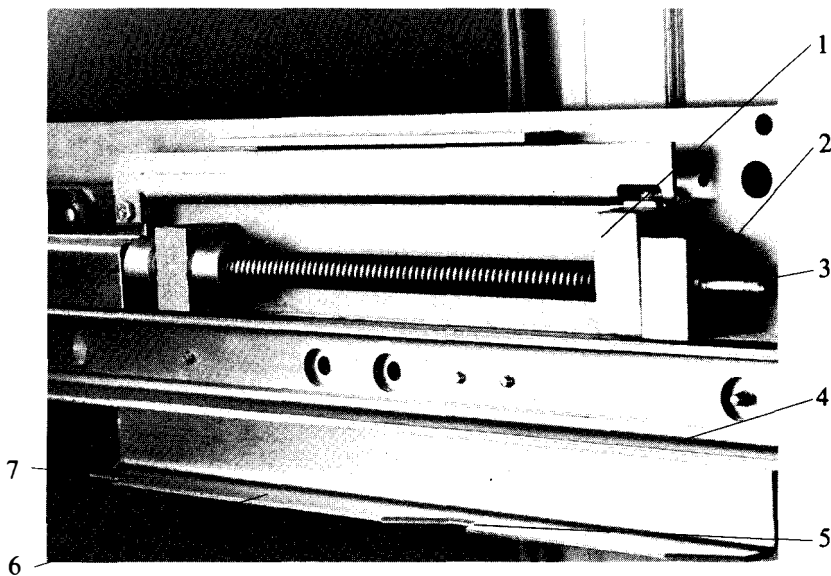

Fig. 43 Closing Spring Discharge Interlock

- 1 — Racking Nut
- 2 — Bearing
- 3 — Jack Screw
- 4 — Rail
- 5 — Disconnect/ Test Slot
- 6 — Operating CAM
- 7 — Connect Slot

Fig. 43 (80184380)

CLOSING SPRING GAG INTERLOCK

An interlock is provided at either the front or rear on the left side of the breaker frame to prevent racking in a breaker which has the spring-blocking device (pin or plate) in the gagged position. The spring-blocking device must be removed so that the interlock interference may reset to allow the breaker to be racked.

See breaker instruction book GEK 90207 or GEK 90208 for use of the closing spring blocking device.

CAUTION: Gagging closing springs when they are in the discharged position can damage the breaker. The breaker side frame may be deformed and/or the gearmotor may be damaged.

KEY LOCKS

On the lefthand breaker racking mechanism track is a provision for a key lock. The purpose of this lock is to keep the breaker from closing in the "Test" and "Connect" positions by operating the negative interlock see Fig. 41. To remove the key (3), push slide (1) to the rear and extend the bolt (4) of the lock into slot. This allows the key to be removed and prevents the breaker from closing. The key lock does not prevent motion of the racking mechanism.

PADLOCKS

Two positions for a possible 3 padlocks each are provided on the racking mechanism. See Fig. 42. The front position keeps the breaker from closing in the "Test" and "Connect" position. To obtain this position push slide (1) Fig. 42 to the rear and insert the padlock in the slotted opening just forward of the keylock (3). This gives the same interlocking functions as the keylock and does not block the motion of the racking mechanism.

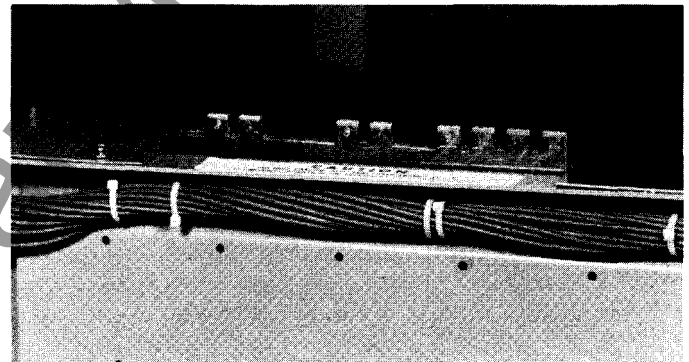

Fig. 44 Interference Interlock

The second position for padlocks (5) is behind the key lock. A padlock in this slot will prevent any motion of the racking mechanism by keeping the hexagon turning shaft covered.

STATIONARY AUXILIARY SWITCH

An auxiliary switch can be provided at the bottom of the breaker compartment so that additional contacts can be actuated by the operation of the breaker. The breaker will operate this switch when it is in the "Test" or "Connect" position. See Fig. 45.

BREAKER POSITION SWITCH

A position switch can be provided at the bottom of a breaker compartment so that it will be operated by a bracket on the breaker frame when the breaker is in the "Connect" position. When the breaker is withdrawn, a spring will return the switch to its normal position. See Fig. 45.

SPACE HEATERS

Space heaters are provided in all outdoor equipment in order to keep the inside temperature several degrees higher

Fig. 44 (8043071)

Fig. 45 (8918438H)

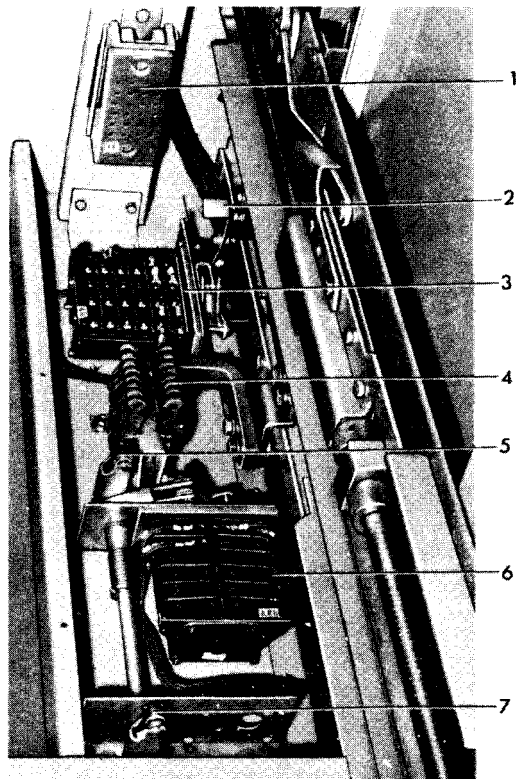

- 1 — Secondary Coupler
- 2 — Position Switch Actuator
- 3 — Position Switch
- 4 — Ground Shoe
- 5 — Stationary Auxiliary Switch Connect Position Actuator
- 6 — Stationary Auxiliary Switch
- 7 — Stationary Auxiliary Switch Test Position Actuator

Fig. 45

Stationary Auxiliary Switch and Breaker Position Switch

than the outside. Heaters are also furnished for indoor equipment when it is known that abnormal atmospheric conditions exist at the installation, or when specified by the purchaser.

By maintaining a slight temperature differential, the heaters help facilitate drying and prevent condensation and the resulting corrosion and insulation deterioration which might occur.

Four 75-watt heaters are provided in each vertical section. One heater is located in each breaker or auxiliary compartment on the bottom at the rear. One heater is also located at the bottom of each cable compartment when breakers are stacked two high. When there is only one breaker per section both heaters are located in the cable compartment at the bottom of the section. Heaters may also be located in transition compartments and in bus ducts if the operating conditions require them.

Before energizing the heaters, be sure the power source is of the proper voltage, frequency, and is connected in accordance with the wiring diagrams furnished with the equipment. Also, be sure to remove all cartons and miscellaneous material packed inside the units before energizing the heaters.

The heater circuit should be inspected several times a year to make sure that it is energized.

MAINTENANCE

CAUTION: BEFORE ANY COVERS ARE REMOVED OR ANY DOORS OPENED WHICH MAY PERMIT ACCESS TO THE PRIMARY CIRCUITS, IT IS ESSENTIAL THAT THE CIRCUITS BE DE-ENERGIZED AND BREAKERS BE WITHDRAWN TO THE TEST POSITION AND TAGGED.

A ten-year preventative maintenance recommendation is effective for Power/Vac* Switchgear shipped after May 1, 1982. It is not a guarantee or warranty, but rather a recommendation for preventive maintenance based on extensive tests and proven reliability. While the user is totally responsible for determining his/her own maintenance policy and inspection routine, this recommendation may be applied to Power/Vac* Switchgear operating under service

conditions with mild environments as defined in ANSI Std. C37-04 — 1979.

For specific information regarding the maintenance of devices such as circuit breakers, relays, meters, etc., refer to the separate instruction book furnished for each device. The test cabinet, which is furnished, provides a convenient means for maintaining the circuit breakers.

A permanent record of all maintenance work should be kept, the degree of detail depending on the operating conditions. In any event, it will be a valuable reference for subsequent maintenance work and for station operation. It is recommended that the records include reports of tests made, the condition of equipment, repairs and adjustments that were made.

The primary circuits of metal-clad switchgear are insulated in order to reduce the size of the equipment. However, this insulation, except in one or two instances, requires a certain amount of air gap between phases and to ground to complete the insulation. Inserting any object in this air space when equipment is energized, whether it be a tool or a part of the body, may under certain conditions short circuit this air gap and may cause a breakdown in the primary circuit to ground and cause serious damage or injury or both.

Care should be exercised in the maintenance and checking procedures that accidental tripping or operation is not initiated.

RECOMMENDED MAINTENANCE

The switchgear structure and connections should be given the following overall maintenance at each maintenance period. All maintenance work must be done with both the primary and control power circuits de-energized.

1. Thoroughly clean the equipment, preferably using a heavy-duty vacuum cleaner to remove all dust and other accumulations. Wipe clean the buses and supports. Inspect the buses and connections carefully for evidence of overheating or weakening of the insulation.
2. Measure the resistance to ground and between phases of the insulation of buses and connections with a 1000 or 2500 volt megger. Since definite limits cannot be given for satisfactory insulation resistance values, a record must be kept of the reading. Weakening of the insulation from one maintenance period to the next can be recognized from the recorded readings. The readings should be taken under similar conditions each time if possible, and the record should include the temperature and humidity.

High-potential tests are not required, but if it seems advisable, based on the insulation resistance tests or after repairs, the test voltage should not exceed 14kV alternating current for 4.16kV and 27kV alternating current for 13.8kV equipment. These voltages are 75 percent of factory test voltages and are in accordance with ANSI standards.

Voltage transformers and control power transformers, surge arresters and surge suppressors must be disconnected during high-voltage testing.

3. Clean racking mechanism and lubricate jack screws and gears with lubricant 0282A2048P009. A periodic overhaul of the racking system should be carried out if more than 500 operations are expected in its lifeline.

4. Check primary disconnecting device contacts for signs of abnormal wear or overheating. Discoloration of the silvered surfaces is not ordinarily harmful unless atmospheric conditions cause deposits such as sulphides on the contacts. If necessary, the deposits can be removed with a good grade of silver polish.

Sandpaper, steel wool or abrasive cleaners should never be used on silver-plated parts. ♦

Before replacing breaker, apply a thin coat of contact lubricant 0282A2048P009 to breaker studs for lubrication.

5. Check to see that all anchor bolts and bolts in the structure are tight. Check tightness and continuity of all control connections and wiring.
6. If the switchgear is equipped with heaters, check to see that all heaters are energized and operating.

Inspect individual heater elements and replace any which have failed.

7. All louvered exterior openings in outdoor equipment are furnished with air filters. The foam filter elements should be removed, washed in warm soapy water, rinsed, dried and then re-assembled at least annually. Elements should be inspected before re-assembly and replaced if any signs of deterioration are evident.

INDOOR AND OUTDOOR ACRYLIC PAINT FINISH

The outside of outdoor switchgear has an acrylic paint finish providing improved resistance to all atmospheric conditions, longer life and less maintenance than with ordinary paint finishes.

PAINT REFINISH/REPAIR

The STANDARD exterior finish for Indoor and Outdoor equipment is *acrylic enamel* ANSI 61 light gray, G.E. number (0282A4534P001).

SPECIAL exterior finishes (optional): ANSI 24 blue-gray (0282A4534P002), Berkshire (medium) green (0282A4534P003) and ANSI 70 sky-gray (0282A4534P004) are *acrylic lacquer*.

If it is necessary to refinish or repair the paint finish, one of the following procedures should be used to secure the best adhesion of the paint to the original finish.

A. REFINISHING WITH ACRYLIC ENAMEL

After lightly sanding, feathering and cleaning the area to be refinished, apply a coat of good acrylic enamel primer-sealer (0282A4534P005). Air-dry the primer for 1/2 hour, then apply the finish color coat of acrylic enamel.

If the area is to be spray-coated, thin the acrylic enamel with (0282A4534P006). (This thinning is only necessary if the paint was received in a five gallon drum.) Use one (1) part

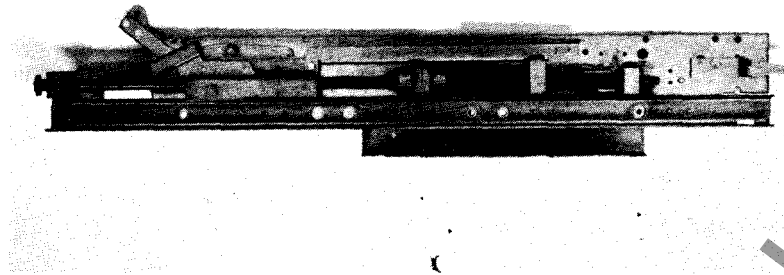

Fig. 46 Right Hand Track Assembly for Vacuum Metal-Clad

thinner to four (4) parts enamel as a starting point to obtain the correct spraying viscosity. When paint is received in less than five gallon quantities the paint has been factory-thinned. Both the primer and paint should be applied only when the temperature is above 55 degrees fahrenheit.

B. REFINISHING WITH ACRYLIC LACQUER

After lightly sanding, feathering and cleaning the area to be refinished, apply a coat of good acrylic lacquer primer-sealer (0282A4534P005). Air-dry the primer for 1/2 hour, then apply the finish color coat of acrylic lacquer.

If the area is to be spray-coated, thin the acrylic lacquer with a blush resistant thinner (0282A4534P007). (This thinning is only necessary if the paint was received in a five gallon drum.) Use one (1) part thinner to one (1) part lacquer as a starting point to obtain the correct spraying viscosity. When paint is received in less than five gallon quantities, the paint has been factory-thinned. Both the primer and paint should be applied only when the temperature is above 55 degrees fahrenheit.

For prices, refer to the nearest office of the General Electric Company.

If insulation material, such as tape, is required, it must be ordered separately from 0282A4530. (Fig. 31)

If parts listed separately are to be assembled at the factory, order must so state.

Not all parts shown herein will be used on all equipment. Parts not used in original equipment should not be ordered as renewal parts. Complete listings of the recommended renewal parts are shown in GEK 39671F and GEK 86132A for ML-17 and ML-18 mechanisms respectively.

RENEWAL PARTS

ORDERING INSTRUCTIONS

Renewal parts should be ordered from the Switchgear Operations.

Always specify the requisition number on which the equipment was originally furnished.

Specify the quantity, reference number, description and this bulletin number; and if possible, pictures of the damaged area.

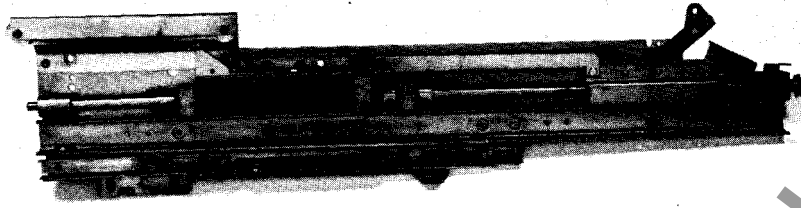

Fig. 47 (8042974)

Fig. 47 Left Hand Track Assembly for Vacuum Metal-Clad

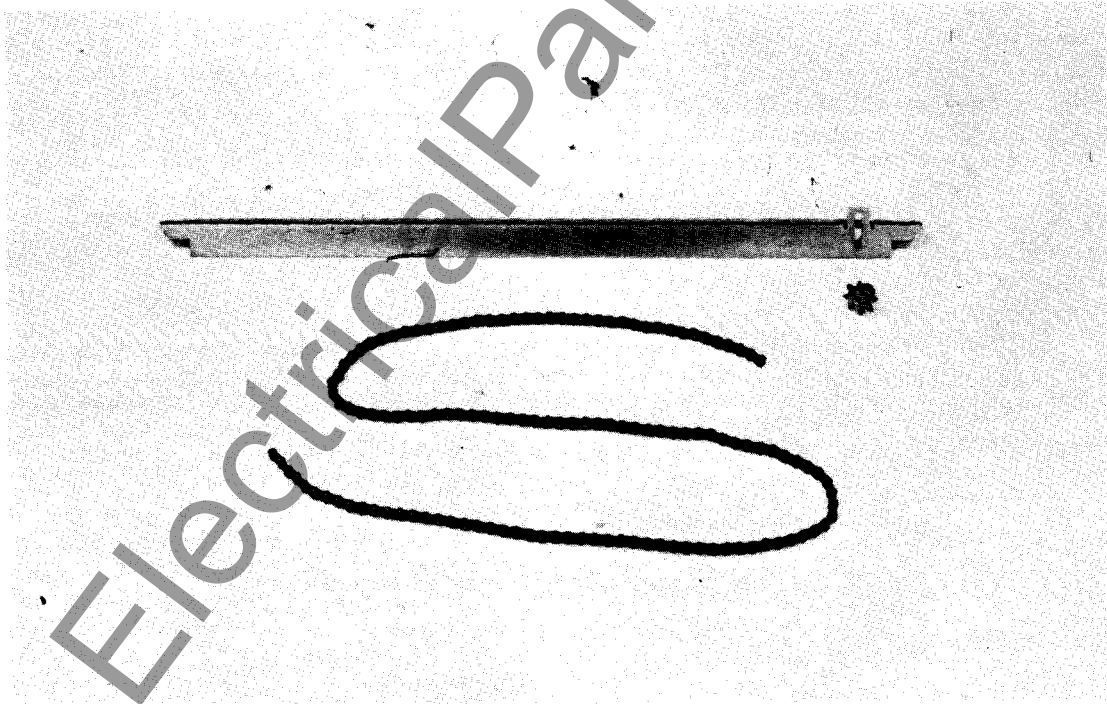

Fig. 48 (8042972)

Fig. 48 Spreader Bar, Chain and Idler Sprocket for Vacuum Metal-Clad

Fig. 49 (80429730)



Fig. 49 Connection Boots for Primary Disconnects, Surge Suppressors, and Bus

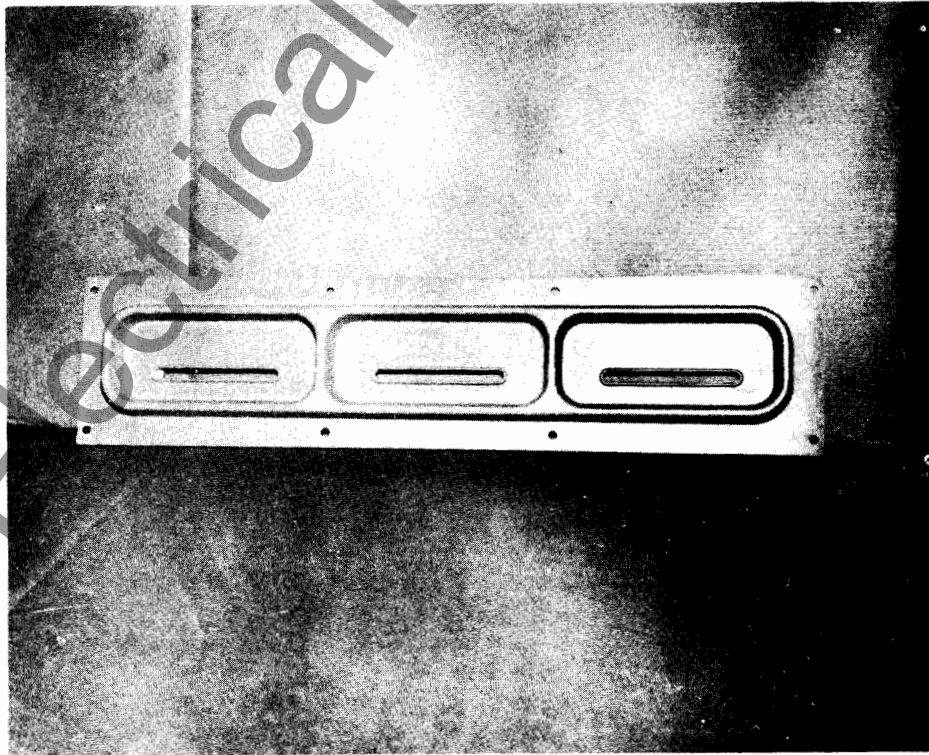

Fig. 50 (8043070)

Fig. 50 Polyester Inter Unit Barrier

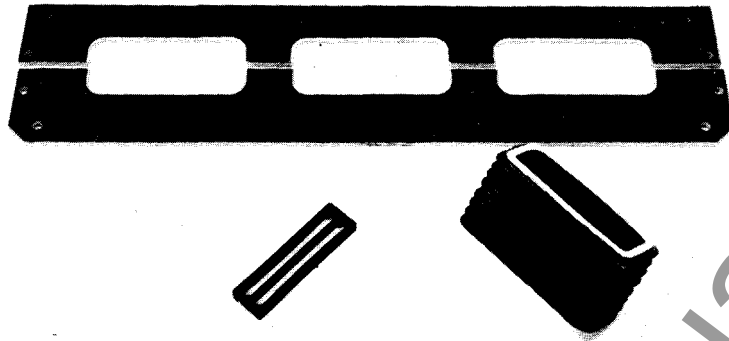

Fig. 51 Porcelain Inter Unit Barrier

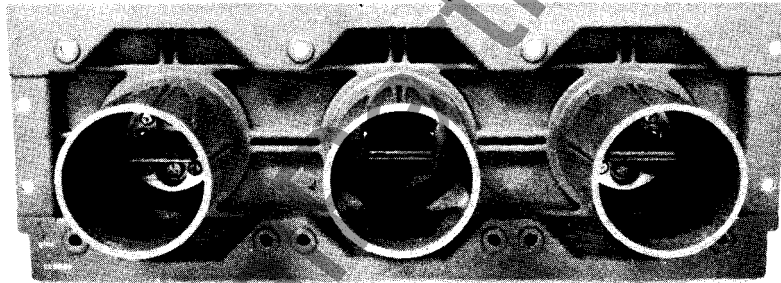

Fig. 52 Polyester Primary Disconnect

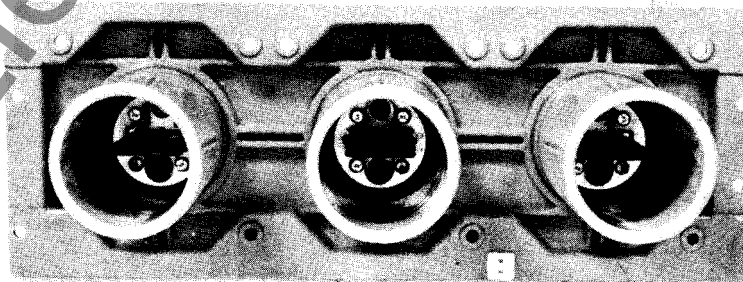

Fig. 53 Porcelain Primary Disconnect

Fig. 51 (8043114)

Fig. 52 (8043057)

Fig. 53 (8043056)

Fig. 54 (8042978)

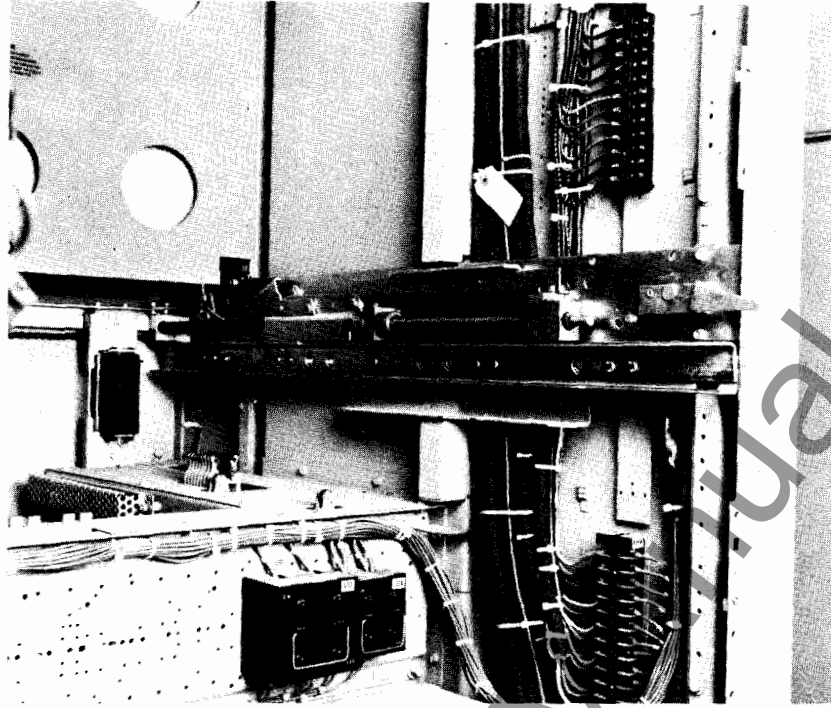

Fig. 54 Vacuum Metal-Clad Breaker Unit

www.ElectricalPartsmaterials.com

www.ElectricalPartManuals.com

www.ElectricalPartManuals.com

GENERAL ELECTRIC COMPANY
SWITCHGEAR OPERATION
BURLINGTON, IOWA 52601

GENERAL  ELECTRIC