

DSP OHMNI

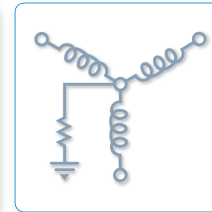

DSP OHMNI

HIGH RESISTANCE
GROUNDING SYSTEM

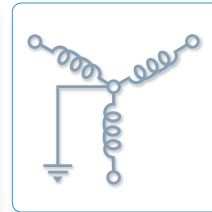
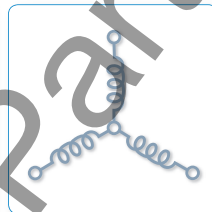
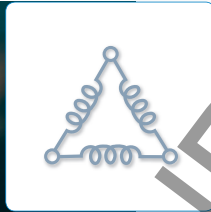
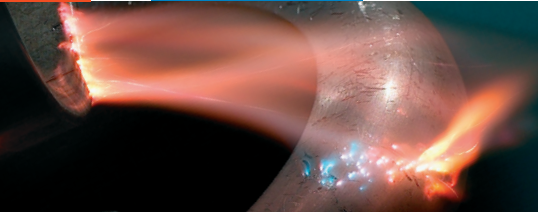

the power to protect

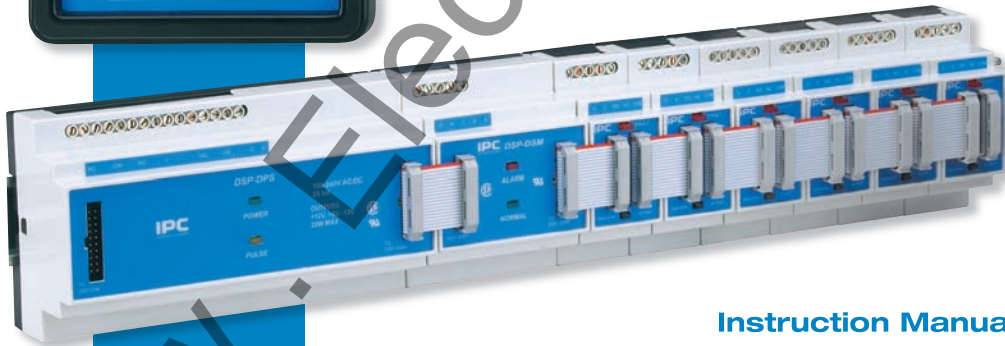

Instruction Manual C-409

IPC

www

HIGH RESISTANCE GROUNDING

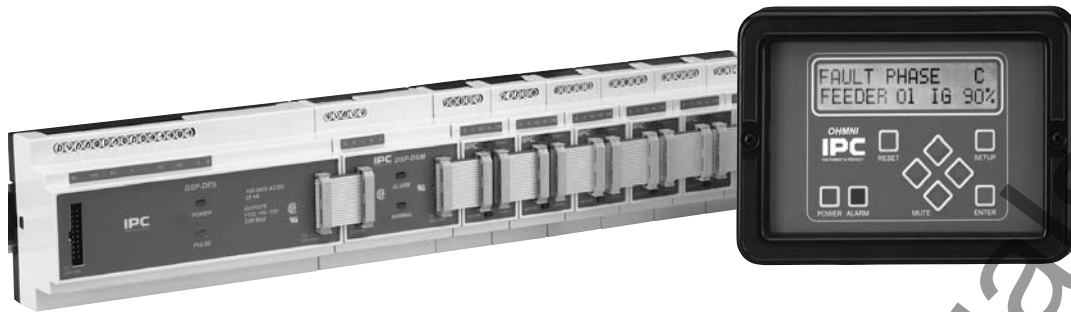

DSP Second Fault Protection – unnecessary outages of electrical power in continuous process industries or in critical systems applications such as hospitals, air traffic control towers etc cannot be tolerated and this has increased the usage of high resistance grounding systems.

The new DSP Ohmni System is designed to provide an alarm, but not trip when one ground fault occurs in the system thus retaining system continuity. If a second fault develops on the system, before an existing fault has been cleared, then the potential for serious damage results.

IMPORTANT

Each DSP module is carefully inspected before packed in a specially designed carton. The unit should be examined immediately upon receipt. If damage or indication of rough handling is apparent, a claim should be filed without delay with the transport company. I-Gard should be notified promptly if replacements for damaged goods are necessary. If units received are not to be installed immediately they should be stored in their original containers in an area free of dust and moisture.

TABLE OF CONTENTS

1 Introduction	3
2 Application	4
3 Installation	5
4 Wiring	6
5 Display	10
6 Setup	11
7 Operation	18
8 Alarm Indications	20
9 Self-Test	22
10 Events	23
11 Maintenance and Testing	24
12 Service	25
13 Communications	25
14 Specifications	31
15 Outline Dimensions	33
16 Additional Information	36
17 Instruction Manuals	ibc

TABLES

<i>Table 3.1 System Module Requirements</i>	5
<i>Table 3.2 Standard Ribbon Cables</i>	5
<i>Table 6.1 Pulsing Frequency Selection</i>	17
<i>Table 13.1 MODBUS RTU Standard 8 Byte Holding Register Read Function (03)</i>	26
<i>Table 13.2 Returned Information Structure for Holding Register Request</i>	26
<i>Table 13.3 Request to Write to Set a Bit on a Register (Modbus Force Coil)</i>	26
<i>Table 13.4 Returned Information from Dsp Following a Force Bit Request</i>	27
<i>Table 13.5 Feeder Module Ground Current Addresses</i>	28
<i>Table 13.6 Feeder Module Status Addresses</i>	29
<i>Table 13.7 Feeder Module Priority Addresses</i>	30
<i>Table 13.8 System Function Registers</i>	31

TABLE OF FIGURES

Figure 4.1 a) Typical One-Line Installation - Unit Substation	b) System Module DSP-DSM Wiring	7
Figure 4.1 c) Power Supply DSP-DPS wiring		7
Figure 4.2 Preferred Feeder Module DSP-DFM Wiring		8
Figure 4.3 Alternative Sensor Wiring		8
Figure 4.4 Typical 4-wire Communications Connection		9
Figure 4.5 Alternative two-wire connection for RS-485		10
Figure 5.1 Home Screen		10
Figure 5.2 Alarm Screen		10
Figure 6.1 Communications Set-up		11
Figure 6.2 Communications Set-up		11
Figure 6.3 Grounding Resistor Set-up		12
Figure 6.4 Feeder Module Set-up		12
Figure 6.5 I/D Check indication		13
Figure 6.6 Feeder Module Set-up		14
Figure 6.7 a) Feeder Module Successful	b) Set-up Not Successful	14
Figure 6.8 a) DSP-DM allows further Feeder Module set-up	b) If previous set-up had not been successful	14
Figure 6.9 Pulse Set-up Request		15
Figure 6.10 Pulse Mode Set-up		15
Figure 6.11 Typical Examples of Pulse Circuit Connection		16
Figure 6.12 Alarm relay Setup		17
Figure 6.13 Alarm relay Options		17
Figure 6.14 Save Screen		18
Figure 6.15 Self-Test Prompt		18
Figure 7.1 Normal Home Screen		18
Figure 7.2 System leakage current I_G		19
Figure 7.3 Feeder Current I_{Gr}		19
Figure 7.4 Trip Defeated		19
Figure 7.5 Pulse Control		20
Figure 7.6 New Home screen indicates Pulsing ON		20
Figure 8.1 Alarm Screen		21
Figure 8.2 Bus Fault		22
Figure 9.1 System-Test Prompt		22
Figure 9.2 Prompt for Feeder Test		22
Figure 9.3 Feeder Module Test		23
Figure 9.4 Test Result		23
Figure 10.1 Event Notification		23
Figure 10.2 Momentary Feeder Fault Example		23
Figure 15.1 DIN Rail Mounted Modules		33
Figure 15.2 DSP-DM Display Module with cut-out detail		34
Figure 15.3 DSP-DPS Power Supply Connections		35
Figure 15.4 DSP-DSM System Module Connection		35
Figure 15.5 DSP-DFM Feeder Module Connection		35
Figure 15.6 DSP-DM Display Module Connections		36

1 INTRODUCTION

High-Resistance-Grounding is becoming more prevalent in industrial and commercial electrical power systems. As the need for reliable and stable power increases the inconvenience of unwanted downtime in processing, robotics and data service also become more critical and costly.

Single Ground Faults in motors and equipment are common and will cause interruption of service in Solidly Grounded systems. HRG prevents this event from happening by limiting the fault current to a sustainable level for an indefinite time.

The DSP system is designed to detect the event of a single fault and signal an alarm condition and point to the affected branch or feeder. Thus maintenance can be immediately alerted to the problem and an operator dispatched to locate the fault to isolate it promptly. The DSP system can assist in locating the fault with a pulsing fault location circuit that modulates the current in the fault. This allows the operator to identify which branch circuit is carrying fault current using a portable clamp-on current probe connected to an ordinary Multi-meter.

The DSP system consists of a number of modules that are mounted on a 35mm DIN rail typically located in a control compartment of switchgear. The modules are connected together through 20-conductor standard ribbon cable. A panel-mounted Display module provides a human interface to the system and communications to a RS-485 network allows set-up and control.

There are four DSP modules as follows:

DSP-DM Display Module

DSP-DPS Power Supply

DSP-DSM System Module

DSP-DFM Feeder Module

The Display Module is a panel-mounted enclosure designed for flush mounting in a door. It is connected by a ribbon cable to the Power Supply unit. The DSP-DM indicates faulted phase, total system leakage current, feeder branch current level and provides other information such as priority settings and Resistor setting etc. It is used to set-up the system and provide manual control of the pulse location system.

The POWER Supply unit DSP-DPS is a DIN rail-mounted modular unit constructed with an ABS enclosure and provides +5V, +12V and -12V regulated supplies to all of the modules through the front ribbon cables. It is capable of operation with a wide range of voltage supplies from 100V to 240V ac without selection of any jumpers or switches. DC voltage can also be used from 125V to 250V DC.

The System Module monitors the system line-to-ground voltages through a standard I-Gard Corp. DDR2 voltage dividing resistor unit. It determines if there is voltage unbalance in the system and the level of ground fault current in the grounding resistor, without any connection to the Resistor.

The Feeder Modules measure the fault current level in the branch circuits that are protected. This module uses standard I-Gard current sensors Type T2A, T3A, T6A and T9A. It is equipped with a form C 10A output Relay that can be used for breaker control. The DSP-DFM detects two fault levels. Firstly it detects the single fault, which creates a System Alarm condition, and secondly through a priority level system it provides breaker control to disconnect the least important circuit breaker.

Communications is provided by a 4-wire RS-485 network connection from a jack located at the rear of the DSP-DM Display module. The communications protocol supported is MODBUS RTU, which is a master/slave system with selectable baud rates from 4800 to 19200. The DSP supports the MODBUS function Read Holding Registers only, without exception support. Additionally it will support remote RESET using the Force Coil function.

2 APPLICATION

The DSP system is used in conjunction with I-Gard, Alarm Resistor Unit Type DDR2. The DDR2 matches the DSP-DSM input circuits to the system voltage and is available in 4 types as follows:

Type	System Voltage
DDR2-1	120V*
DDR2-2	240V
DDR2-4	480V
DDR2-6	600V

* Also used with potential transformers up to 13.8KV

The DDR2 provides output voltages V_{AG} , V_{BG} , V_{CG} that are proportional to the phase to ground voltage and also voltage V_{NG} that is proportional to the neutral resistor voltage. (i.e. Total leakage/fault current of the system)

On large systems provision is usually made to ground the system using a current-limiting resistance (I-Gard Type OHMNI-PM or NGR). On ungrounded systems there is always leakage capacitance to ground from each line. Re-striking ground faults may cause an excessive build up of line to ground voltage due to this capacitance. It may be stabilized with the addition of a grounding resistance, thus preventing costly breakdown of insulation.

The Type OHMNI-PM is connected between ground and the star point of the transformer on Wye systems. On Delta systems an artificial neutral device (I-Gard Type DDAI) is required to provide a star point. Both OHMNI-PM and DDAI devices are selected for appropriate current 'let-through', i.e.: The current, which will flow to ground, if there is a direct short from line to ground (on any one phase).

NOTE: A good Rule-of-Thumb for Resistor current selection is 1 ampere per 2000KVA, if no surge capacitors are on the system, and 1 ampere per 1000KVA with surge capacitors. For further information please refer to www.i-gard.com/appguides.htm

DDAI and OHMNI-PM devices are available for continuous currents of 1 ampere to 10 amperes for most systems. For further information regarding the use of these devices refer to:

Instruction Manual Type DDAI Artificial Neutrals	C-430EM
Instruction Manual Type DDR2 Alarm Resistor Units	C-440EM
Instruction Manual Type OHMNI-PM Neutral Grounding Resistors	C-450EM

3 INSTALLATION

A typical installation will include for each power source (transformer/generator) 1 DSP-DM, 1 DSP-DPS, 1 DSP-DSM and a number of DSP-DFM Feeder Modules as required with 1 for each branch protected. Additionally there will be a DSP-PM pulsing resistor to ground the system. A voltage-sensing resistor DDR2 is required for the DSP-DSM input, as well as one current sensor for each DSP-DFM for current detection. See Table 3.1 for typical requirements.

TABLE 3.1 SYSTEM MODULE REQUIREMENTS

Catalog Number	Description	No Required/System
DSP-DM	Display Module	1
DSP-DPS	Power Supply	1
DSP-DSM	System Voltage Module	1
DSP-DFM	Feeder Module	As required 1/ Circuit
OHMNI-PM	Pulse Equipped Resistor	1
DDR2	Voltage Sensing Resistor	1
DDAI	Artificial Neutral	Required only for delta system
T	Toroidal Current Sensor	1/Feeder Module

TABLE 3.2. STANDARD RIBBON CABLES

Length	Function	Catalog Number
365cm (12ft)	DSP-DM to DSP-DPS	DRC-365
150cm (5ft)	DSP-DM to DSP-DPS	DRC-150
5cm (2 in.)	Module to Module connection	RC-3
30cm (12 in.)	Module to Module connection	RC-30

DSP modules are mounted on a 35mm DIN Rail generally located at the rear wall of a switchgear compartment. They should be mounted side by side and connected with 20-conductor ribbon cable in a daisy chain configuration. This applies to the DSP-DPS, DSP-DSM and DSP-DFM modules only.

DSP (Outline Dimensions). Care should be taken not to over tighten the 8-32 nuts used to retain the DSP-DM

It will be necessary to provide a reliable power source (which is not interrupted by operation of the DSP output contacts) for control power. The supply should be 100-240 V AC/DC. The control supply must be fused by 1 Ampere fuses as shown in Fig. 4.1 a (Connection Diagram). Ideally the alarm, warning bell should be connected to a separate control supply from the DSP (see para. 8.3.1).

4 WIRING

No. 14 or No. 16 switchboard wire is used for all current sensor, control and DDR2 connections, which need not be shielded. 4-wire shielded cable should be used for the serial communications, however. A typical wiring schematic is shown in Figure 4.1a.

Sensor wiring is not generally limited by length and may be up to a kilometer without degradation of performance, since the sensor is a current source. Sensor wiring should be run in separate conduit from Power wiring. The recommended sensor wiring connections are shown in Figure 4.2. Two wires should be run from each sensor X1 and X2 as indicated to prevent cross coupling between Modules. If existing wiring does not allow this connection because of common connection at X2 as has been common in some installations, then the G terminals of the DSP-DFM modules should be connected as shown in Figure 4.3.

Ribbon cables are available in different lengths as shown in Table 3.2. For other lengths contact I-Gard. The DRC-cable from the DSP-DM to the DSP-DPS, apart from being different in length, also differs in the orientation of the connector. This allows the cable to be run easily from the DSP-DM towards the DSP-DPS power supply. The RC-cables are used for Module to Module connections and are short in length. Note the orientation of the plug as marked on the DSP-DM display module. If a second row of modules is installed on another DIN rail, the last module on the right can be connected to the last module on the right on the second row using the RC-30 cable. Either slot can be used on the DSP-DFM feeder modules for connection.

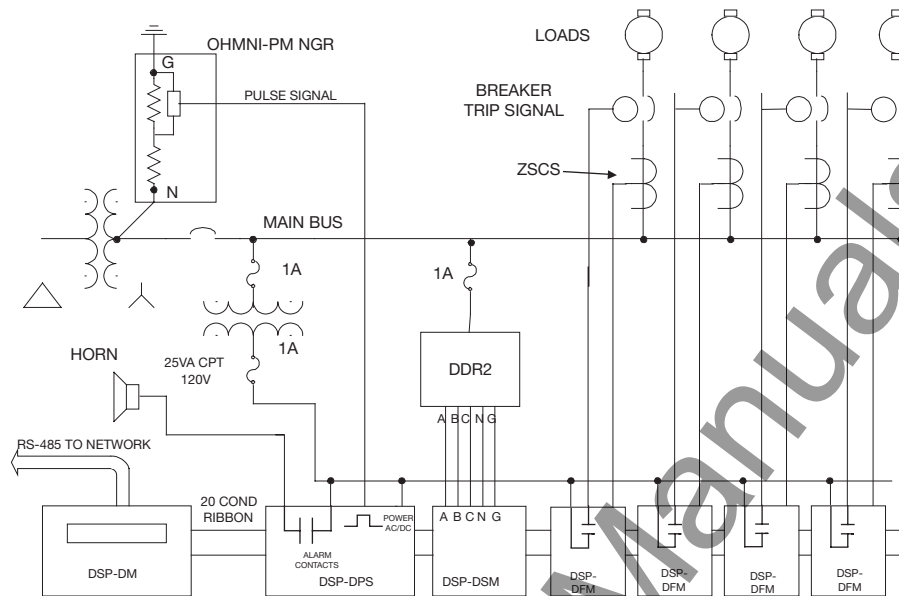

Figure 4.1a Typical One-Line Installation - Unit Substation

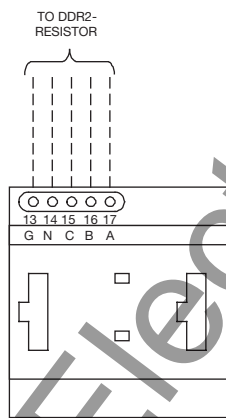

Figure 4.1b System Module DSP-DSM Wiring

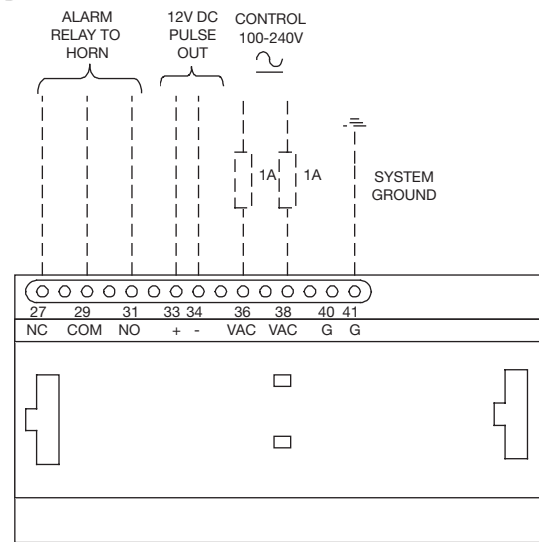

Figure 4.1c Power Supply DSP-DPS wiring

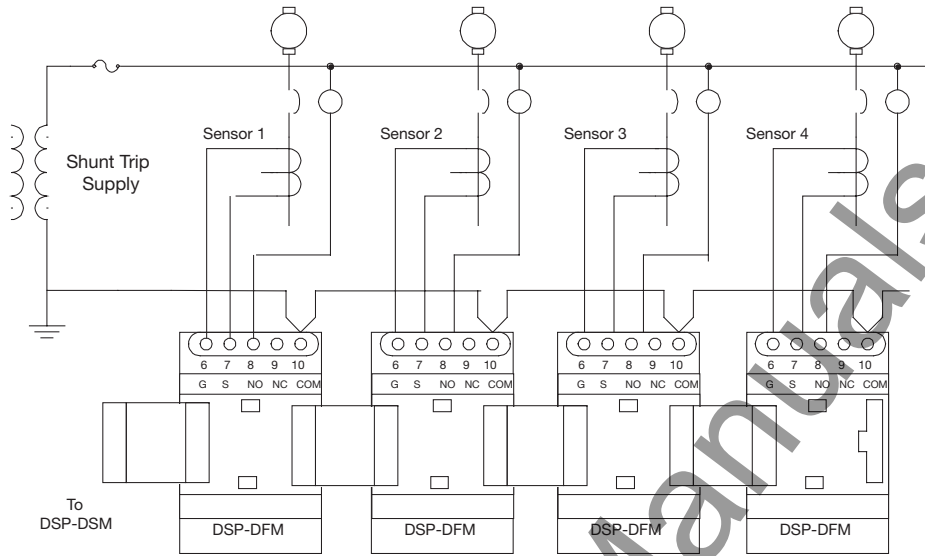

Figure 4.2 Preferred Feeder Module DSP-DFM Wiring

NOTE: For Main-Tie-Main systems and multiple sources with tie breakers the priority buses can be joined together with the use of I-Gard devices DSP-CAS and DSP-CA Modules. The DSP-CA module converts ribbon cable to an 8-conductor shielded cable for this purpose. The DSP-CAS does the same thing except that it includes an electronic switch to make or break the connections when the tie breakers are closed or open. This eliminates the use of 8-pole contactor arrangements of previous systems. The two modules are DIN rail mounted similar to the other DSP modules in 70mm wide housing. See information on DSP-CA(S) or manual C-414EM for typical wiring.

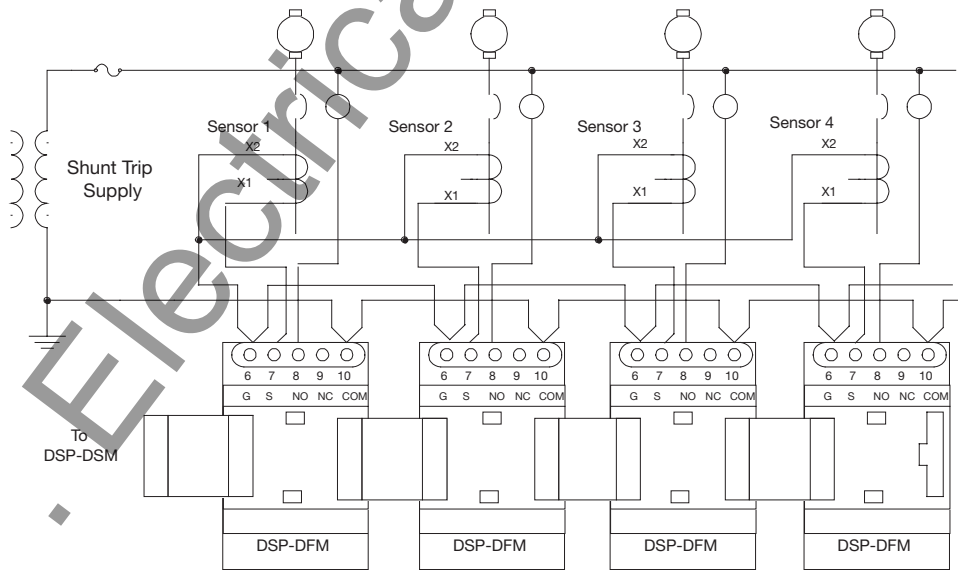

Figure 4.3 Alternative Sensor Wiring

The RS-485 cable shield should be grounded at the ground terminal provided on the 5-pin jack as shown in Figure 4.4, which shows a typical installation with a local computer and LAN.

Communications may be supported as a node in an existing MODBUS network or may be connected through a standard RS-485 to RS-232 converter to a PC with supporting software.

The Alarm contacts are available at the DSP-DPS as a Form C type and should be connected to operate a horn or other means to alert an operator to the fact that a fault has occurred on the HRG system. The contacts are rated at 10A, 240VAC Resistive.

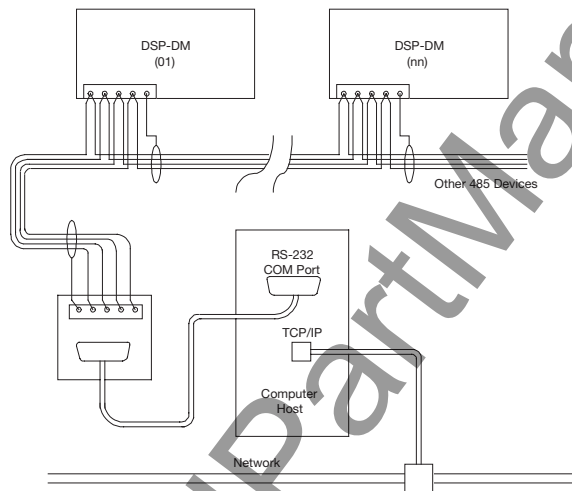

Figure 4.4 Typical 4-wire Communications Connection

Communications wiring may be 2-wire or 4-wire but must use shielded cable with low capacitance. Wire lengths up to 2000 metres can generally be used without the need for termination resistors.

Figures 4.4 and 4.5 show typical RS-485 arrangements with a RS-485/RS-232 converter and a host PC connected to a LAN.

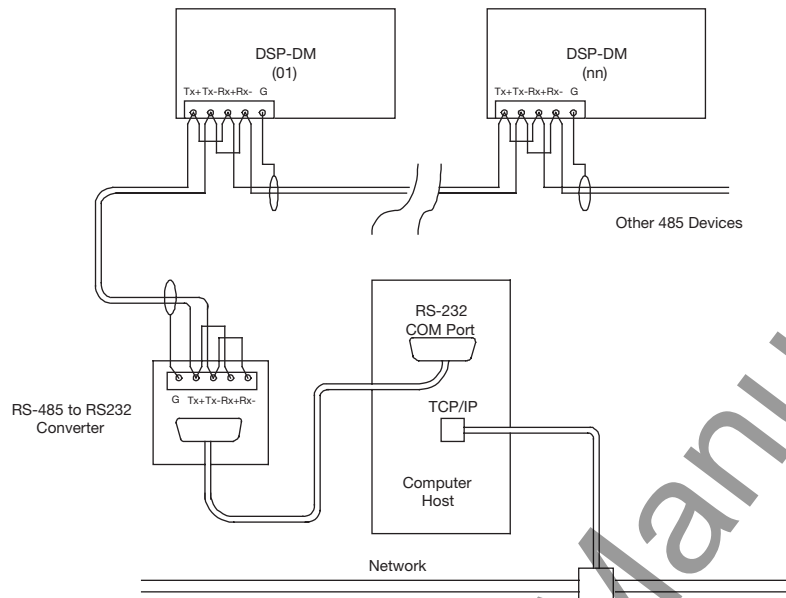

Figure 4.5 Alternative two-wire connection for RS-485

For Fault location the DSP system is equipped with Pulse modulation for the ground current to identify the fault more readily. Pulse current is provided at the DSP-DPS (+) and (-) terminals, which may be directly connected to the Pulse Relay in the DSP-PM grounding Resistor. It is important to observe the polarity of the connection. This 12V wiring need not be shielded but should be 14 AWG switchboard wire for durability.

5 DISPLAY

Following successful installation of the DSP system and connection of the control voltage, the DSP-DM display module should indicate a Green NORMAL light and the screen should show the following message.

**I-GARD
HRG SYSTEM OK**

Figure 5.1 Home Screen

If the following screen appears and the local Alarm sounds, then most likely the DDR2 resistor is not energized or connected.

**3 PHASES LOST
CHECK DDR2 FUSE**

Figure 5.2 Alarm Screen

Most of the screen navigation is done with the ► key on the faceplate label of the DSP-DM. Pressing this key once will switch screens to the System Status screen which shows the total system leakage IG. This is derived from voltage measurement of the system voltages and is proportional to the current through the grounding resistor of the system. It should appear as in Figure 5.1. This is the Home Screen, Screen1, which is the NORMAL starting screen after RESET is pressed. Various messages may modify this screen following an event such as a fault, loss of fuse, or during pulsing to provide some diagnostic information.

6 SETUP

On a new installation some simple set-up is required with at least Maximum System Current (NGR set-up) and Feeder Modules being set prior to use of the equipment. Optional settings are Communications and Pulse Control.

6.1 Communications

To enter the Set-Up Mode press SETUP when the Home Screen or Alarm Screen is showing (SETUP will not enter from any other screens). If confused at any point, press RESET and the Home Screen (or Alarm Screen - if a fault has occurred) will be shown. Figure 6.1 shows the first set-up screen that will be encountered – COMMS set-up mode.

<p>SETUP COMMS? Y/N</p>

Figure 6.1 Communications Set-up

If you are not using the RS-485 connection, then press **ENTER** to skip to the next set-up, otherwise press ◀ to move the flashing cursor to select Y (for Yes) and press **ENTER**. The communications screen will appear similar to Figure 6.2. The screen will show the set-up presently in use, or the default as shown.

<p>MODBUS 1/D 01 BAUD RATE 4800</p>

Figure 6.2 Communications Set-up

The DSP system must be identified by a number from 01 to 32, to distinguish between it and other MODBUS devices that may be connected on the same RS-485 network. If only one device is used then it will typically be set to 01, which is the default value. (Ensure that no other device has the same I/D setting on the RS-485 network or data will not be valid). To change the number, use the ▲▼ arrows to increase/decrease the digit under the flashing cursor and ►◀ to change digits.

When a desired number has been entered press ENTER to change the Baud Rate setting if required. The present rate will be shown. Press ▲ to select another setting. Only three baud rates are provided (4800, 9600 and 19.2K).

Keep pressing the ▲ button and the selection will simply scroll through the three settings until ENTER is pressed to finalize the Communications Set-up and show the screen of Figure 6.3. Select Y to enter this set-up or ENTER to move to Feeder Module Set-up.

6.2 NGR

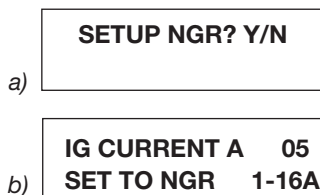

Figure 6.3 Grounding Resistor Set-up

The next screen following Communications is the Grounding Resistor Setting. This setting must be set according to the current limiting value of the grounding Resistor of the HRG system. The default value is 1A. To change the number, use the ▲▼ arrows to increase/decrease the digit under the flashing cursor and ►◀ to change digits.

The final value must be between 01 and 16 for 1-16A range. Press ENTER when completed.

CAUTION! THE SYSTEM WILL ALLOW YOU TO SELECT INVALID NUMBERS OUT OF RANGE, WITHOUT WARNING, BUT THE RESULTS WILL BE INDETERMINATE.

6.3 Feeder Module

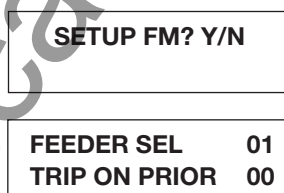

Figure 6.4 Feeder Module Set-up

Following the OHMNI-PM set-up the display prompts for Feeder Module Set-up. Select Y to enter the Feeder Module setup screen as shown in Figure 6.4 (b).

After installation of Feeder Modules they must be given identification numbers from 01 to 50 (maximum) so that the Display unit can determine which module it is talking to. Each module must have a different number. To change the number, use the ▲▼ arrows to increase/decrease the digit under the flashing cursor and ►◀ to change digits.

The Display module is the master module and is constantly sending requests for data from each feeder module from 1 to 50. The Feeder Modules compare the request I/D with their own I/D to decide whether or not they are being asked for data. If the I/D is the same then that Feeder Module replies with Current, Priority and Status information to the master Display Module. **Therefore it is very important that there are not modules in the chain with the same I/D.** The Feeder Select program checks for duplicate I/D when ENTER is pressed following an entry of FEEDER SEL xx. If an existing I/D is detected, the screen will indicate as in Figure 6.5.

I/D IN USE	01
TRIP ON PRIOR	00

Figure 6.5 I/D Check indication

In this case the user must enter a different I/D number before proceeding further. The user is allowed another chance to enter a valid I/D number before the cursor moves to TRIP ON/OFF selection. This permits the TRIP and Priority of previously set modules to be changed while retaining the same I/D number.

CAUTION! IT IS ENTIRELY POSSIBLE FOR THE USER TO ENTER A NUMBER OUTSIDE THE RANGE 01 TO 50 AND THE SYSTEM WILL ACCEPT IT WITHOUT WARNING, DATA WILL NOT BE COLLECTED FROM SUCH MODULES, ALTHOUGH THEY WILL CONTINUE TO PROVIDE FAULT PROTECTION.

Typically, the numbers will be in the sequence 1,2,3,4... but they can be in any order physically. The Display Module does not care. The identification number, however, must be known for each feeder circuit since the Display does not support the use of Text Labelling to identify circuits. Note: This can be done with user-provided software from the RS-485 network if required or by use of the DSP.net server package downloadable from the I-Gard web site. See communications section.

Press ENTER to select the Ident Number. The cursor then drops to TRIP ON setting which is the normal setting. To disable the TRIP function of the Feeder Module press ◀ arrow in which case no priority is required to be set and the Screen of Figure 6.6 is presented.

If the TRIP feature is to be retained (normal setting) pressing ENTER will then allow the user to set the priority of the selected Feeder I/D. To change the number, use the ▲▼ arrows to increase/decrease the digit under the flashing cursor and ▶◀ to change digits. The range of priority numbers is from 00 to 15 with 0 being a lower priority than 15. In the case of Priority numbers it is OK to use the same number more than once unlike the I/D numbers, so that unimportant circuits can all be set to 00, for example.

When the desired priority for a given I/D number has been selected, press ENTER. You will then be prompted with the screen of Figure 6.6

**PUSH FM BUTTON
AND THEN ENTER**

Figure 6.6 Feeder Module Set-up

At this point select the DSP-FM module that is to have the I/D that was set-up, and press the TEST button on that module. The red FAULT light will turn on to indicate the received I/D signal.

Press ENTER to complete the process. The DSP-DM will display either of the following messages depending on whether or not the setup was successful.

**FM ACCEPTED
CONTINUE →**

a) Feeder Module Successful

**FM NOT ACCEPTED
CONTINUE →**

b) Set-up Not Successful

Figure 6.7

Press ► to exit the screen and the DSP-DM will allow the user to set-up more Feeder Modules with screen 10 a) and b)

**FM ACCEPTED
ANOTHER? Y/N**

a) DSP-DM allows further Feeder Module set-up

**FM NOT ACCEPTED
ANOTHER? Y/N**

b) If previous set-up had not been successful

Figure 6.8

If more Feeder Modules need to be set-up then select Y and ENTER to repeat, or if not select N and ENTER to exit the Feeder Module Set-up and enter the PULSE Set-up. The Pulse set-up screen allows the pulsing mode for fault location to be changed for different frequencies and mode of operation. The screen of Figure 6.9 is shown.

6.4 Pulsing

SETUP PULSE? Y/N

Figure 6.9 Pulse Set-up Request

PULSE INVRT? OFF
FREQ 0 LOCK? OFF

Figure 6.10 Pulse Mode Set-up

Select Y to enter the Pulse Set-up Screen which looks like Figure 6.10 which will show the existing set-up of the PULSE module. The pulsing information is stored in the DSP-DSM, which must be installed during setup. Press ◀ to toggle the setting ON or OFF as required.

6.4.1 Invert / NDR MAL

The output from the DSP-DPS module is connected to a solid state relay. Normally (non Inverted operation) the output from the '+' and '-' terminals of the DSP-DPS module is zero prior to any pulsing operation, and the relay is OFF. If Inverted mode is selected, then this voltage is 12V dc. And the relay is, therefore, energized continuously. The choice of NORMAL or INVERTED operation depends on how the Grounding Resistor current is connected. If the Grounding resistor consists of two series or two parallel resistors (one main resistor and one pulse resistor) with the pulse resistor to be switched in and out by a solid state relay then the following two options exist.

a) Pulse Up current

Pulsing upwards means to increase current from IGmax 5A to IGmax 10A, for example. In this case the pulse resistor is normally OFF and the INVRT OFF would be selected. Pulsing would then change the current to a higher level from 5A to 10A alternating when a 100% fault exists.

b) Pulse Down current

Pulsing downwards means to reduce the current from IGmax 5A to IGmax 2.5A, for example. In this case the pulse resistor will be Normally ON and thus the INVRT ON mode would have to be selected. This will mean that the solid state relay will be ON when the system is normal (no fault) and will open when pulsing is started thus reducing current.

See Diagram 6.11 for examples of both series and parallel connected resistor arrangements.

NOTE: the INVRTed mode is the mode used with the standard OHMNI-PM resistors as supplied by I-GARD.

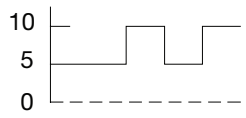
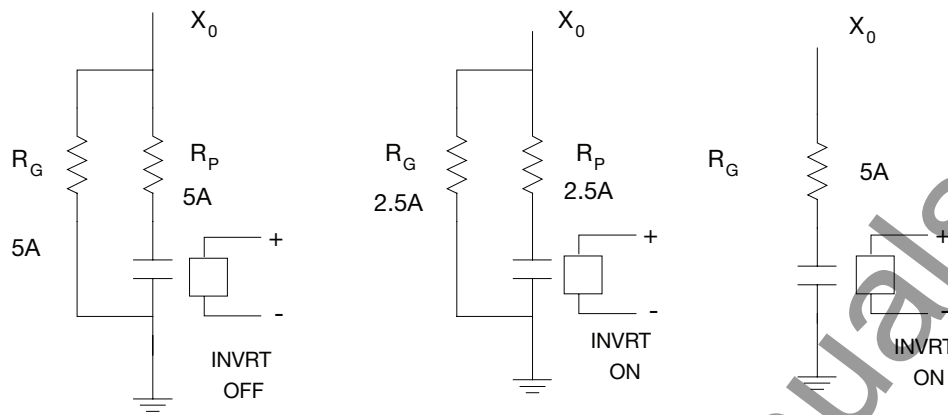

a) Pulse UP Parallel Resistors

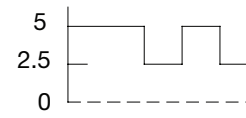

b) Pulse Down Parallel Resistors

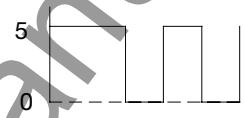

c) Single Resistor

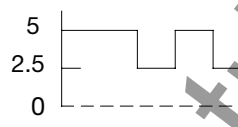
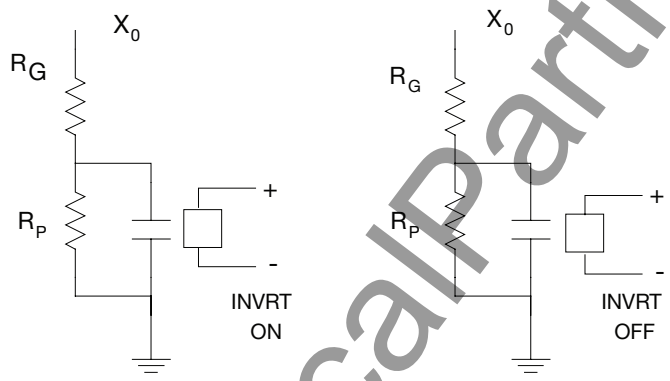

a) Pulse UP Parallel Resistors

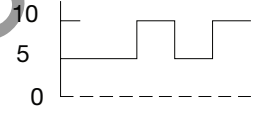

a) Pulse UP Parallel Resistors

Figure 6.11 Typical Examples of Pulse Circuit Connection

6.4.2 Pulsing Frequency

Press ENTER when the selection is chosen. The cursor will then move to the FREQUENCY position. Press ▲▼ to select a pulse frequency from 0 to 9 with frequency increasing with the number selected. It is not important to know exactly the frequency selected, however, Table 6.1. Indicates the frequency for each setting.

TABLE 6.1 PULSING FREQUENCY SELECTION

Select	0	1	2	3	4	5	6	7	8	9
Freq Hz.	1.0	1.25	1.50	1.75	.2.00	.2.25	2.50	2.75	3.00	3.25

6.4.3 Interlock

Press ENTER after a value has been selected and the cursor moves to the interLOCK position. The interlock prevents pulsing from occurring when there is no fault on the system. Press ◀ to toggle ON or OFF and then ENTER to complete the Pulse set-up.

6.5 Alarm Relay

For the next Setup the user will then be presented with the option to change the operation of the MUTE function. The MUTE button normally disables the Alarm Relay and the local Beeper Alarm when pressed to following a fault. However, the designer might use the Alarm Relay for some other function, for example another contactor or cooling fan operation of the grounding resistors. In this case it is undesirable to MUTE the relay. For this reason the operator may choose to disallow the MUTE button to change the state of the Alarm Relay. The Screen of Figure 6.12 is presented.



Figure 6.12 Alarm relay Setup

Selection of 'Y' provides the option selection screen of Figure 6.13.



Figure 6.13 Alarm relay Options

The default is with the Alarm Relay MUTE control Enabled to allow Silence control of an external Horn system. Pressing ← button will toggle the ENABLED to DISABLED to defeat the MUTE switch operation of the Alarm Relay and allow it to be used for other purposes which depend on whether or not the system is in a Faulted condition.

NOTE: This does not affect the local Beeper function which will still continue to be MUTED by the MUTE button.

That completes the set-up. At this point you may be presented with the option of saving the values changed or not with the screen of Figure 6.14.

SAVE CHANGES Y/N

Figure 6.14 Save Screen

Note: You may not see this screen. If no changes were made in the set-up, or changes were made to the Feeder Module set-up or the Pulse Set-up, it will not appear. This is because those changes are actually saved in the DSP-DFM and DSP-DSM respectively. The changes selected will be saved in non-volatile EEPROM memory until the next time the set-up is changed and re-saved.

Pressing ENTER after selecting Y/N.

6.6 Self Test

At this point the user is asked if SELF-TEST is desired with screen of Figure 6.15.

SELF-TEST? Y/N

Figure 6.15 Self-Test Prompt

The user can just press ENTER to ignore and return to the Home Screen, or select Y ENTER to perform Self-Test on the system. See Self-Test section for details. See Section 9 for Self-Test.

7 OPERATION

7.1 Screen Navigation

Normally with an un-faulted system and recent RESET, the Display Module will display the Normal Home screen of Figure 7.1 with a green NORMAL light on the front panel and no Alarm. The System Module will indicate a green NORMAL light and the DSP-DFM modules will show no light indication at all. The DSP-DPS supply will also indicate POWER with a green light when power is supplied to it. The yellow PULSE light may, or may not, be ON, depending on whether, or not, the INVERTed mode of operation has been selected for the pulse operation. If the Inverted Mode is selected the Pulse Relay will be normally energized and will de-energize with each pulse. The PULSE light will indicate when the pulse relay is energized. In the Normal pulse mode, the light will be OFF and will light with each pulse. The Display Module will indicate the Normal Home screen as in Figure 7.1.

I-GARD RESISTORS
HRG SYSTEM OK

Figure 7.1 Normal Home Screen

Pressing ► takes the user to the Screen 2 which shows the total system ground current I_G as a percentage of the maximum ground current allowed by the grounding Resistor. As a reference, the setting for the Maximum Ground current is shown as $I_G \text{ max}$ (5A in the example of Figure 7.2). The $I_G \text{ max}$ current must agree with that of the Neutral Grounding Resistor of the system. If it does not then the OHMNI-PM set-up must be repeated.

IG SYSTEM A =10%
100%(IGmax) =05A

Figure 7.2 System leakage current I_G

NOTE this screen can only be seen when the system does not have a fault as will be seen.

Press ► again to view Screen 3 which is the Feeder Module screen in Figure 7.3 below. It allows the user to examine the status of the installed DSP-DFM modules. Feeder Modules are identified by their I/D numbers from 1 to 50 and may be scrolled through with the ▲▼ keys. Priority settings can be observed (10 in this case) and Ground Current I_{Gf} for the Feeder is displayed as a percentage of the maximum Ground Current of the System. A reading of "- -" would represent a direct short to ground for the Feeder while 00% represents no current leakage at all. STATus is indicated as well which shows whether or not the Feeder Module is **OK** (leakage below 50%), **FLT** (faulted) leakage greater than 50% or **TRP** (Tripped) which may happen if a second fault caused current in the sensor to exceed 100A for 200mS or more.

FDR 01 PRIOR 10
1Gf 07% STAT OK

Figure 7.3. Feeder Current I_{Gf}

Only those DSP-DFM modules that have valid I/D settings will indicate successfully. All others will indicate as though they were not installed with blank characters in the display fields.

NOTE: to identify which DSP-DFM is which, if not sure, the user can push the I/D/TEST button on each DSP-DFM until the Status indicator on the Feeder Screen shows **TST**. This will be the FM selected and the I/D can be read on this screen.

If the TRIP function was defeated in the Setup Mode, then the Feeder Modules that are disabled will indicate with a screen similar to Figure 7.4

FDR 01 TRIP OFF!
1Gf 07% STAT OK

Figure 7.4 Trip Defeated

7.2 Pulsing

Press ► to move to the next screen. This is the Pulsing Control Screen. It appears as in Figure 7.5.



Figure 7.5 Pulse Control

This screen is only used to turn on the Pulsing System for fault location. It will cause the OHMNI-PM Grounding Resistor value to be modulated to permit readings to be easily detected on portable current probes. Pulsing is toggled ON and OFF with the ◀ button. The bottom line of the display indicates the Status of the Pulsing Module. It should change to ON when pulsing is ON. Note: If the Pulsing cannot be turned ON, it could be because the InterLOCK setting has been set to ON in the Pulse Set-up. In this case Pulsing cannot be turned ON unless there is an actual fault on the system. This can be easily changed in the Set-up configuration.

If Pulsing is selected ON, then it will remain ON until turned OFF again or RESET is pressed. The Home screen will remind the Operator that pulsing is ON with the screen of Figure 7.6.



Figure 7.6 New Home screen indicates Pulsing ON

12V DC Pulse current is sent from the DSP-DPS '+' and '-' terminals to the DSP-PM Grounding Resistor to energize the solid-state relay in the Resistor and by-pass part of its elements to modulate the Ground Current (if any).

When finished with the Pulse operation press ► to exit and return to the Home Screen.

8 ALARM INDICATIONS

If a fault greater than 50% of IG develops somewhere on the system, and Alarm is declared by the System Module, this causes several events to occur.

LED indications

DSP-DM display module green NORMAL changes to red ALARM

DSP-DSM system module red ALARM light

- ◆ DSP-DFM Fault Indication is enabled to provide indication if Fault is detected by Feeder Module (Fault may not be detected by a Feeder Module - if it is on the Main Bus for example)

Alarms

Alarm Relay (Form C) on DSP-DPS will operate to energize customers' alarm device (Horn etc.)

A local beeper will sound in the DSP-DM to indicate the fault

The Alarms both local and external can be cancelled by the MUTE button, which is actually the key when in the Alarm Screen. It will not work on the Feeder or Pulse Screens. Once cancelled the Alarm will remain OFF until about an hour after the last button has been pressed on the keypad of the DSP-DM when it will resume if an Alarm condition still exists. RESET will also cancel the MUTE effect.

Display

The Home screen will change to an Alarm Screen which will indicate which phase is faulted, and the branch circuit that is affected, with a screen similar to that of Figure 8.1.



FAULT PHASE A
FEEDER 01 IG 67%

Figure 8.1 Alarm Screen

The faulted Feeder is identified by I/D number. The Total System Current IG will indicate the system current as determined by the voltage from the DDR2 resistor unit (See 8.1 above). Note this may not be exactly the same as the Feeder Current I_{gf} that is indicated in the Feeder Module Screen since the sum of all leakages will not necessarily be the same as that of one particular Feeder branch.

Feeder fault information can be determined by pressing ► to move to the Feeder Screen. The Faulted Feeder (if any) can be located by scrolling with ▲▼ keys to the faulted one. The current reading I_{gf} relating to that feeder is shown. It should exceed 50%. The **FLT** status will also confirm that this is the faulted circuit. In addition, there will be an Alarm Indication on the faulted Feeder Module which is indicated by a continuous red LED.

In this situation it then becomes necessary to determine the source of the fault. In some cases this might be known problem but if the fault is not quickly identified then the risk is that a second fault may develop and cause shutdown of one of the breakers.

To locate the fault easily the Pulse system can be turned on using ► to enter the Pulse Control screen. See Fault Finding section.

If no Feeder Faults are identified the Display Module will indicate BUS FAULT as in Figure 8.2 to indicate this special situation. In this case the probability is that there is a fault upstream of the current sensors and usually indicates a fault in the main transformer or bus duct which supplies the switchgear.

**FAULT PHASE A
BUS FAULT IG 67%**

Figure 8.2 Bus Fault

This screen may also be observed under other situations as well. For example if a fault develops on a faulty DSP-DFM or the Module is missing or a Feeder has no protection on it at all, the same indication will result. Another situation might be on a main-tie-main system with two DSP systems and a fault develops on one side of the gear. The DSP-DM on the other side will indicate Alarm with a BUS FAULT if the tie is closed since it does not 'see' any DSP-DFM on its side with a fault.

9 SELF - TEST

Basic functionality testing of the system can be done without interrupting circuit breakers. To enter the Test the operator must be in the Home Screen and without a fault on the system at the time. Press SETUP button. Using the ENTER key press 4 times until the SELF-TEST screen is reached, Select Y and ENTER to access the Self-Test. The operator is prompted with the TEST SYSTEM test as in Figure 9.1

**TEST SYSTEM?
Y/N**

Figure 9.1 System-Test Prompt

To check the SYSTEM Module DSP-DSM, select Y and ENTER otherwise just push ENTER to move to the Feeder Module Test.

If the SYSTEM was selected when ENTER is pressed, the Red Alarm lights on System Module and Display Module will light and both the local and remote Alarm devices will sound. Check that the MUTE button silences the Alarms effectively.

The prompt figure 9.2 for Feeder Module DSP-DFM automatically appears at this time. Select Y or ENTER to perform the Feeder Module Test. Pressing ENTER will return the display to the Home Screen.

TEST FEEDER? Y/N

Figure 9.2 Prompt for Feeder Test

The second line of the display will indicate that it is ready for a Feeder Module Test with the screen of Figure 9.3.

**TEST FEEDER? Y/N
FM NO.**

Figure 9.3 Feeder Module Test

At this point the operator may press any DSP-DFM TEST button and if it is good the Display will respond with the I/D number of the selected Feeder Module and acknowledges with "OK" as in the example of Figure 9.4

**TEST FEEDER? Y/N
FM NO. 5 OK**

Figure 9.4 Test Result

Press any other Feeder TEST button to check other modules similarly.

Press ENTER to leave the Self-Test and return to the Home Screen.

10 EVENTS

When a fault occurs sufficient to cause an alarm the event is recorded along with the fault current level and location so that it can be checked on the DSP-DM display module, even if the fault has disappeared. This can be seen on the Home screen which indicates a fault occurrence with a message as in Figure 10.1.

**I-GARD
FAULT CLEARED ←**

Figure 10.1 Event Notification

To observe what event occurred press ◀ as indicated and hold to read the data. The display will show the type of fault, phase faulted and the branch location if any. For example Figure 10.2 shows a typical Feeder Fault that was momentary.

**FAULT PHASE A
FEEDER 03 IG 78%**

Figure 10.2 Momentary Feeder Fault Example

The following Events are supported:

Type of Event	Interpretation	Possible Cause
Bus Fault	Fault occurred which was not identified by any Feeder Module	a) Fault upstream in duct or transformer
		b) Fault in unprotected Feeder branch
Phase Loss	Loss of a phase on the DDR2 resistor	Fuse Open
3- Phases Lost Feeder Fault	No power on DDR2 resistor unit Fault occurred on identified Feeder	Power Disconnected Momentary Ground Fault on Feeder



The event will remain until superseded by another fault, which will rewrite over the previous data. The data is volatile and will be cleared on a power interruption or operation of the RESET button.

11 MAINTENANCE AND TESTING

Due to the solid state design and the use of sealed components, it is not necessary to service the DSP other than occasionally dusting with a damp cloth or vacuum cleaner during regular switchboard maintenance.

To test the DSP it will normally be sufficient to use the SELF-TEST procedure (as described in section 9).

To test the system in the field involves placing a ground fault on one of the lines. This should only be performed with the permission of the owner and by qualified individuals using proper techniques, to ensure safety to plant, equipment and personnel.

 DANGER 
Hazard of Electrical Shock, Burn or Explosion
All installation, servicing and testing referred to in this manual must be performed by qualified personnel. All power should be disconnected prior to removing covers or enclosures and where live conductors may otherwise be exposed.
Failure to observe these precautions may result in death or severe personal injury and damage to equipment.
Before placing an intentional ground fault on the power system, check that a fault does not already exist. Any test ground fault equipment must be rated for full system voltage and be fused for protection.

A complete test of the system can be accomplished with the connection of a resistive fault between one of the three lines and ground at a location downstream of one of the Feeder current sensors. This simple test will identify the integrity of sensor, Feeder Module circuits, connections, communications, System Module operation, DDR2 resistor OHMNI-PM resistor and Pulsing without causing a Trip to occur on any of the breakers. The only thing it will not test is the priority of the double-fault trip process. For this two such resistors would be required, with resistor value low enough to provide more than the 100A trip current.

NEVER USE A PIECE OF WIRE TO CREATE A TEST FAULT. IT IS POSSIBLE THAT THE PROTECTION MAY NOT BE OPERATIONAL DUE TO MIS-WIRING OR OTHER PROBLEMS AND CANNOT CLEAR THE FAULT CURRENT RESULTING IN A SERIOUS ARCING SITUATION WHICH MAY SEVERELY DAMAGE THE EQUIPMENT AND CAUSE INJURY OR DEATH.

12 SERVICE

For assistance in installation, setup or testing please call I-Gard toll free at **1-888-737-4787 (1-888-RESISTR)**

There are no user-serviceable parts in the DSP, therefore all service should be referred to qualified factory representatives, other than direct replacement of entire Modules to I-Gard. Please visit the I-Gard website for information regarding field service representatives in your area. (www.i-gard.com)

NOTE: Please ensure that proper authorisation is obtained from I-Gard before returning the equipment.

13 COMMUNICATIONS

Installation

To allow communications to a remote terminal or network, a 4-wire RS-485 communications jack is provided at the rear of the DSP-DM Display Module. The 5-pin connector supplied has screw terminals and allows disconnection without breaking the RS-485 daisy chain. A ground connection is supplied for grounding the shield of the 4-wire cable. The protocol supported is MODBUS RTU. The baud rate can be changed in the DSP-DM set-up to 4800, 9600 or 19200 as desired. The frame set-up is 8 bit, No Parity and 1 Stop Bit. The VD number for the DSP-DM must be entered in the set-up within the range of 1 to 32. Cable should be standard 4-wire with two twisted-pairs ideally, and a grounding shield for emc protection. The shield of the cable between nodes should not be continuously grounded, but each section of cable should be grounded at GND pin of J3. When installing cable, avoid star connections and make connections flow from node to node. Cable length of 1-2 kilometres or more should be easily accommodated.

DSP MODBUS output structure

Two functions are supported
 Read Holding Register (03)
 Set Coil (05)

There are 154 registers available, which can be accessed by an external host system. This document summarizes the format and function of these registers.

The request from the master is always 8 bytes long and are as shown in Table 13.1.

TABLE 13.1 MODBUS RTU STANDARD 8 BYTE HOLDING REGISTER READ FUNCTION (03)

Unit I/D	Function	Starting Address		No. of Registers requested		CRC	
		High	Low	High	Low	High	Low
01	03	00	01	00	02	nn	nn

All bytes are in hexadecimal. Numbers above are, for example, a request for 2 registers only, starting from address 01. CRC checksum is 16 bit CRC as described in MODBUS information. The high bytes are not used in any requests.

If successful the DSP will return the message shown in Table 13.2.

TABLE 13.2 RETURNED INFORMATION STRUCTURE FOR HOLDING REGISTER REQUEST

Unit I/D	Function	No. of bytes		Data 1		Data 2		CRC	
		High	Low	High	Low	High	Low	High	Low
0103	00	02	00	02	00	01	nn	nn	

Register contents are shown in Tables 1 to 3 as follows.

NOTE: Register number is shown in decimal but must be sent in hexadecimal form in the request.

The only write functions presently supported in the DSP system are RESET control and PULSE ON/OFF which will require the use of Set Coil function in MODBUS. The format for Setting is as shown in Figure 13.3

TABLE 13.3 REQUEST TO WRITE TO SET A BIT ON A REGISTER (MODBUS FORCE COIL)

Unit I/D	Function	Coil Address		Force Coil		CRC	
		Low	High	Low	High	Low	High
01	05	00	00	ff	00	nn	nn

In this case there will only be two 'coils' (actually DSP functions)

'Coil' No	Name	Force Coil Data	
00	Reset	ff00 =on	0000=off
01	Pulse	ff00 =on	0000=off

The response of Table 13.4 will confirm the request

TABLE 13.4 RETURNED INFORMATION FROM DSP FOLLOWING A FORCE BIT REQUEST

Unit I/D	Function	Coil Address		Force Coil		CRC	
		High	Low	High	Low	High	Low
01	05	00	00	ff	00	nn	nn

Which is just an echo of the request.

The registers can be read either one at a time or in a continuous block up to a maximum of 100 registers at a time.

There are times when the DSP processor will not be able to respond to a request since it is busy with other tasks and no response will be returned. For this reason it is recommended to request the maximum number of registers used by the system in a single request. Since the DSP is set up to 50 current registers, 50 Status registers and 50 Priority registers followed by the System function registers, it is best to read the data with three consecutive requests.

NOTE that the DSP will not respond to requests if the DSP-DM is in the SETUP mode.

The Feeder Module currents I_{gf} values are contained in the first 50 registers as follows. The values range from 0x00 to 0xff although maximum for a first fault condition will be 0x64 or 100%. Table 13.5 lists the register addresses in the MODBUS convention.

www.ElectricalPartManuals.com

TABLE 13.5 FEEDER MODULE GROUND CURRENT ADDRESSES

Register No	Contents	Format	Register No.	Contents	Format
40001	Feeder 1 lgf	0x00nn	40026	Feeder 26 lgf	0x00nn
40002	Feeder 2 lgf		40027	Feeder 27 lgf	
40003	Feeder 3 lgf		40028	Feeder 28 lgf	
40004	Feeder 4 lgf		40029	Feeder 29 lgf	
40005	Feeder 5 lgf		40030	Feeder 30 lgf	
40006	Feeder 6 lgf		40031	Feeder 31 lgf	
40007	Feeder 7 lgf		40032	Feeder 32 lgf	
40008	Feeder 8 lgf		40033	Feeder 33 lgf	
40009	Feeder 9 lgf		40034	Feeder 34 lgf	
40010	Feeder 10 lgf		40035	Feeder 35 lgf	
40011	Feeder 11 lgf		40036	Feeder 36 lgf	
40012	Feeder 12 lgf		40037	Feeder 37 lgf	
40013	Feeder 13 lgf		40038	Feeder 38 lgf	
40014	Feeder 14 lgf		40039	Feeder 39 lgf	
40015	Feeder 15 lgf		40040	Feeder 40 lgf	
40016	Feeder 16 lgf		40041	Feeder 41 lgf	
40017	Feeder 17 lgf		40042	Feeder 42 lgf	
40018	Feeder 18 lgf		40043	Feeder 43 lgf	
40019	Feeder 19 lgf		40044	Feeder 44 lgf	
40020	Feeder 20 lgf		40045	Feeder 45 lgf	
40021	Feeder 21 lgf		40046	Feeder 46 lgf	
40022	Feeder 22 lgf		40047	Feeder 47 lgf	
40023	Feeder 23 lgf		40048	Feeder 48 lgf	
40024	Feeder 24 lgf		40049	Feeder 49 lgf	
40025	Feeder 25 lgf		40050	Feeder 50 lgf	

Feeder Module Status is represented by five valid states as follows:

0x00 = OK

0x01 = Faulted feeder

0x02 = Feeder Tripped

0x03 = Test Button pushed

0x0f = Not available

The registers following return two bytes – The first byte is always 0x00 with the second returning status in hexadecimal as above.

TABLE 13.6 FEEDER MODULE STATUS ADDRESSES

Register No.	Contents		Register No.	Contents	
	Function	Format		Function	Format
40051	Feeder 1 Status	0x00nn	40076	Feeder 26 Status	0x00nn
40052	Feeder 2 Status		40077	Feeder 27 Status	
40053	Feeder 3 Status		40078	Feeder 28 Status	
40054	Feeder 4 Status		40079	Feeder 29 Status	
40055	Feeder 5 Status		40080	Feeder 30 Status	
40056	Feeder 6 Status		40081	Feeder 31 Status	
40057	Feeder 7 Status		40082	Feeder 32 Status	
40058	Feeder 8 Status		40083	Feeder 33 Status	
40059	Feeder 9 Status		40084	Feeder 34 Status	
40060	Feeder10 Status		40085	Feeder 35 Status	
40061	Feeder 11 Status		40086	Feeder 36 Status	
40062	Feeder 12 Status		40087	Feeder 37 Status	
40063	Feeder 13 Status		40088	Feeder 38 Status	
40064	Feeder 14 Status		40089	Feeder 39 Status	
40065	Feeder 15 Status		40090	Feeder 40 Status	
40066	Feeder16 Status		40091	Feeder 41 Status	
40067	Feeder 17 Status		40092	Feeder 42 Status	
40068	Feeder 18 Status		40093	Feeder 43 Status	
40069	Feeder 19 Status		40094	Feeder 44 Status	
40070	Feeder 20 Status		40095	Feeder 45 Status	
40071	Feeder 21 Status		40096	Feeder 46 Status	
40072	Feeder 22 Status		40097	Feeder 47 Status	
40073	Feeder 23 Status		40098	Feeder 48 Status	
40074	Feeder 24 Status		40099	Feeder 49 Status	
40075	Feeder 25 Status		40100	Feeder 50 Status	

TABLE 13.7 FEEDER MODULE PRIORITY ADDRESSES

Register No.	Contents		Register No.	Contents	
	Function	Format		Function	Format
40101	Feeder 1 Priority	0x00nn	40126	Feeder 26 Priority	0x00nn
40102	Feeder 2 Priority		40127	Feeder 27 Priority	
40103	Feeder 3 Priority		40128	Feeder 28 Priority	
40104	Feeder 4 Priority		40129	Feeder 29 Priority	
40105	Feeder 5 Priority		40130	Feeder 30 Priority	
40106	Feeder 6 Priority		40131	Feeder 31 Priority	
40107	Feeder 7 Priority		40132	Feeder 32 Priority	
40108	Feeder 8 Priority		40133	Feeder 33 Priority	
40109	Feeder 9 Priority		40134	Feeder 34 Priority	
40110	Feeder10 Priority		40135	Feeder 35 Priority	
40111	Feeder 11 Priority		40136	Feeder 36 Priority	
40112	Feeder 12 Priority		40137	Feeder 37 Priority	
40113	Feeder 13 Priority		40138	Feeder 38 Priority	
40114	Feeder 14 Priority		40139	Feeder 39 Priority	
40115	Feeder 15 Priority		40140	Feeder 40 Priority	
40116	Feeder16 Priority		40141	Feeder 41 Priority	
40117	Feeder 17 Priority		40142	Feeder 42 Priority	
40118	Feeder 18 Priority		40143	Feeder 43 Priority	
40119	Feeder 19 Priority		40144	Feeder 44 Priority	
40120	Feeder 20 Priority		40145	Feeder 45 Priority	
40121	Feeder 21 Priority		40146	Feeder 46 Priority	
40122	Feeder 22 Priority		40147	Feeder 47 Priority	
40123	Feeder 23 Priority		40148	Feeder 48 Priority	
40124	Feeder 24 Priority		40149	Feeder 49 Priority	
40125	Feeder 25 Priority		40150	Feeder 50 Status	

TABLE 13.8 SYSTEM FUNCTION REGISTERS

Register	Function	Format	Description
40151	System IG current	0x00nn	nn = 0-100% Total System leakage current I _g
40152	System Status	0x00nn	Nn 01 = Normal no fault 10 = A phase low 20 = B phase low 40 = C phase low 70 = All phases low 82 = A phase faulted 84 = B phase faulted 88 = C phase faulted
40153	Pulse setup	0x00nn	nn lower byte is a composite byte upper nibble is Mode of operation while lower nibble of nn is pulse frequency 0 – 9. nn 0n = Normal, interlock OFF 1n = Inverted, interlock OFF 2n = Normal , interlock ON 3n = Inverted, interlock ON
40154	Pulse Status	0x000n	n 0=Pulsing OFF 1=Pulsing ON

14 SPECIFICATIONS

14.1 Power Requirements DSP-DPS

100-240V, 50/60Hz or DC, 25VA

14.2 Maximum Ratings DSP-DPS

Control voltage	250V AC/DC
Dielectric	
Relay contacts to chassis	1500V rms. for 1 minute
Control terminals to chassis	1500V rms. for 1 minute
DC output maximum rating	22W max for +5, +12 and 12V supplies

Settings DSP-DSM System Module

Alarm Level Pickup	50% of system Ground Current I_G
Trip Level Inhibit	25% of system Ground Current

14.3 Pulse Set-up

Pulse Rates	
0 to 9 Setting in 0.25Hz increments	
1.0, 1.25, 1.50, 1.75, 2.0, 2.25, 2.50, 2.75, 3.0, 3.25Hz.	
Pulse Modes	Normal, Inverted
Pulse Interlock	Normal, Interlocked with Fault Detect.
Pulse Output current	0.5A @ 12V DC

14.4 DSP-DFM

Ground Current Settings I_G	1, 2, 3, 4, 5, 6, 7, 8, 9, 10, 11, 12, 13, 14, 15, 16A
Trip Level Current	100A
Trip Level Delay	10xP + 200mS (Where P=Priority setting)
Priority Levels	0 – 15 (16 settings)

14.5 Contact Ratings

DSP-DFM Trip Contacts – Form C SPDT	10 amperes, 240V AC resistive
DSP-DPS Alarm Contacts – Form C SPDT	8 amperes, 240V AC resistive

14.6 Performance

DSP-DFM	
Pickup accuracy	±10% of system let-through current
Trip Level accuracy	±10A
DSP-DSM	
Alarm Level Accuracy	±10% of I_G
Meter accuracy	±10% of I_G

NOTE: Accuracy based on single resistance fault, at nominal line voltage, without system capacitance.

Temperature Range:	Operating temperature 0°C–+50°C
Standards	CSA File number LR65287 UL E232710

Physical

Weight 1.5kg

Dimension

See Fig. 17(next)

I-Gard reserves the right to change specifications of its products without notice.

15 OUTLINE DIMENSIONS

Figure 15.1 shows typical Dimensional details of the Polymeric enclosures used for the modules.

All have the same cross-section dimensions but with different widths *W* as shown.

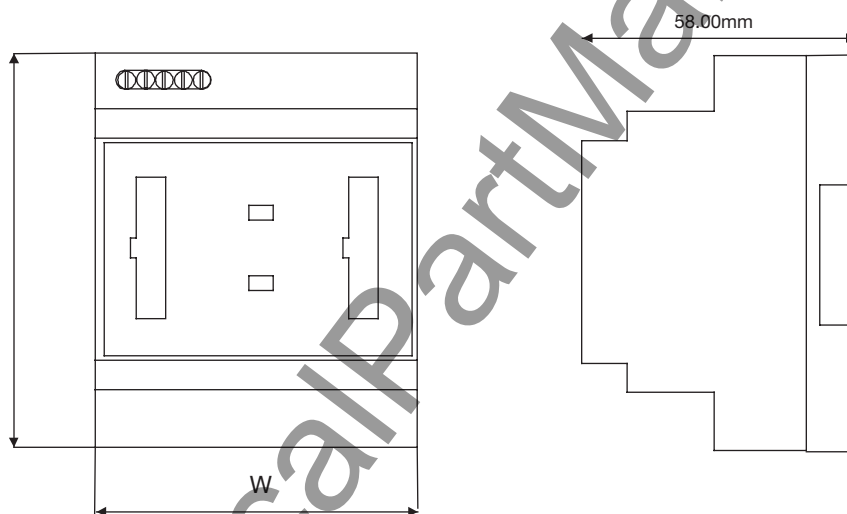

Figure 15.1 DIN Rail Mounted Modules

Module	W
DSP-DFM	35mm (1.377 in.)
DSP-DSM	70mm (2.755 in.)
DSP-DPS	155mm (6.102 in.)
DSP-CAS	70mm (2.755in.)
DSP-CA	70mm (2.755in.)

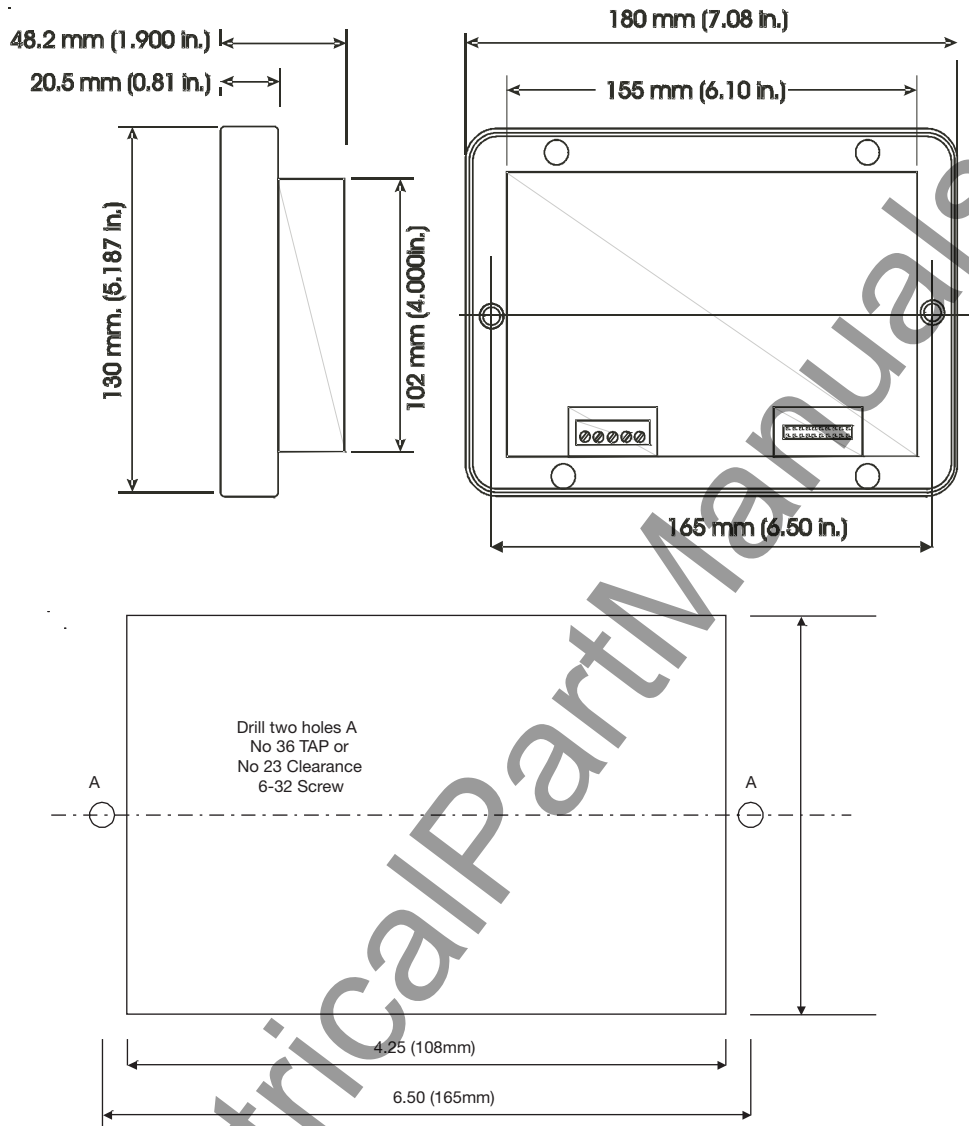

Figure 15.2 DSP-DM Display Module with cut-out detail

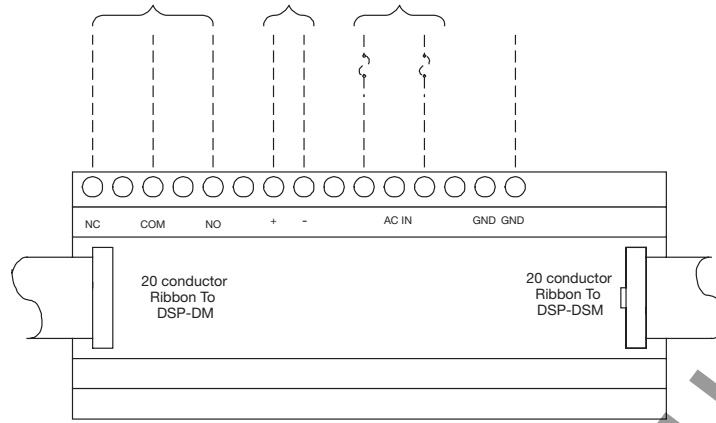

Figure 15.3 DSP-DPS Power Supply Connections

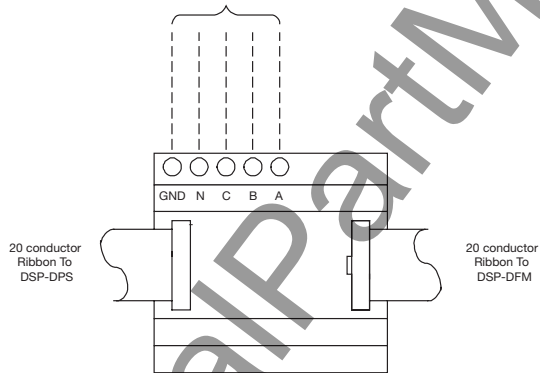

Figure 15.4 DSP-DSM System Module Connection

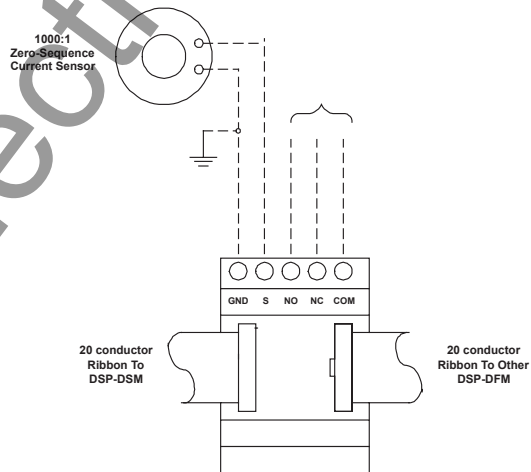

Figure 15.5 DSP-DFM Feeder Module Connection

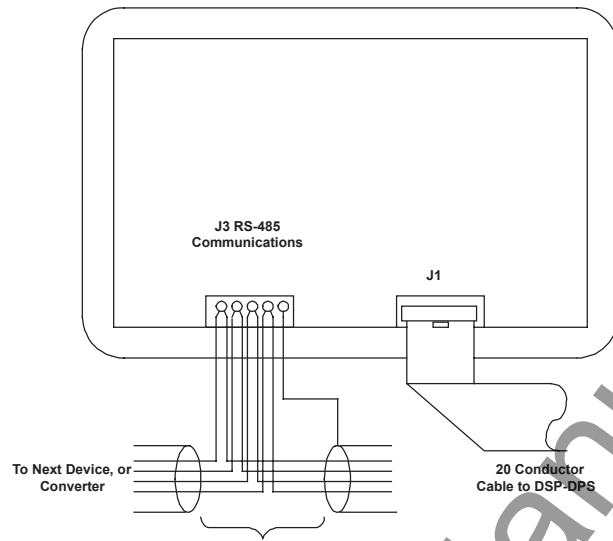

Figure 15.6 DSP-DM Display Module Connections

16 ADDITIONAL INFORMATION

If you require more information or experience problems with your equipment that persist after taking the steps identified in this manual, please contact I-Gard Customer Service.

17 INSTRUCTION MANUALS



C-101 Stoplight
High Resistance Grounding System Manual



C-102 Gemini
High Resistance Grounding System Manual

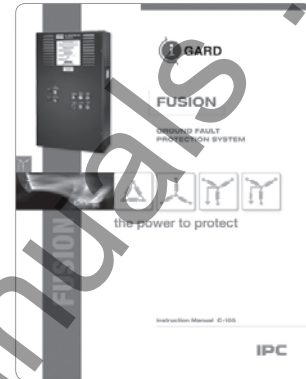

C-105 Fusion
Ground Fault Protection System Manual



C-322 MGFR
Ground Fault Relay Manual



C-407 GCHK-100 Mining Relay
Ground Fault Protection System Manual



C-408 Sleuth
High Resistance Grounding System Manual

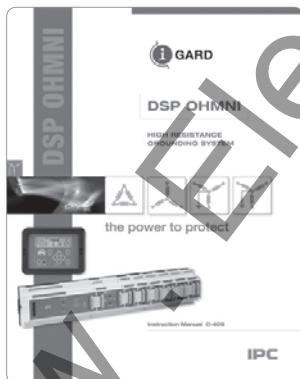

C-409 DSP OHMNI
High Resistance Grounding System Manual



C-403 GFR-RM SIGMA
Resistor Monitoring and Ground Fault Relay



C-107 SENTINEL
High Resistance Grounding System

www.the power to protect

ElectricalPartManuals.com



7615 Kimbel St., Unit 1
Mississauga, Ontario
Canada L5S 1A8

Phone 905-673-1553
Toll Free 1-800-737-4787
Fax 905-673-8472
e-mail: sales@i-gard.com
www.i-gard.com