

# MERLIN GERIN

## molded case circuit breaker

The CF type covers continuous current ratings from 70 to 250A with the following standard features :

- 2 and 3-pole versions
- moisture and fungus protection
- true positive break indication
- reinforced insulation
- integral partitioning (insulated accessory compartment)
- snap-in field installable accessories
- internal accessories designed with screw terminals – no wires
- push to trip
- ease of installation
- reverse feeding
- maintenance-free operation

## compliance with international standards

In addition to UL489 and CSA C22-2 no.5 the Compact line circuit breakers has been designed to comply with the international standard IEC 157-1 as well as with these other major standards :

- british BS 4752,
- german VDE 660,
- french NF C63-120,
- australian AS 2184

The Compact line circuit breakers have been approved for marine application by American Bureau of Shipping, Bureau Veritas, Lloyd's Register of Shipping, Registro Italiano Navale, Germanische, Lloyd's and Det Norske Veritas.

## ratings

9 ratings from 70 to 250 Amperes.  
Non interchangeable trip units.

ampere ratings(A)	magnetic setting (A)	
	low	high
<b>CF 250N - CF 250H - CF 250L</b>		
70	fixed at 700	
90	fixed at 900	
100	fixed at 1000	
125	750	1250
150	900	1500
175	1050	1750
200	1200	2000
225	1350	2250
250	1500	2500
<b>CF 250HC - CF 250LC</b>		
150	900	1500
250	1500	2500

## interrupting ratings

CF type	UL listed - CSA approved interrupting ratings		
3-pole	RMS Sym. Amps		
600Y/347V AC	240V	480V	600V

### standard breakers

CF 250N	65,000	35,000	10,000
---------	--------	--------	--------

### high interrupting breakers

CF 250H	100,000	42,000	10,000
---------	---------	--------	--------

### current limiting breakers

CF 250L	150,000	150,000	65,000
---------	---------	---------	--------

### motor circuit protectors

CF 250HC	100,000	42,000	10,000
----------	---------	--------	--------

CF 250LC	150,000	150,000	65,000
----------	---------	---------	--------

## mounting

- fixed
- plug-in on insulated plug-in base
- drawout on fixed cradle (not UL - not CSA)

## terminals

- standard pads for bars or cable lugs
- optional pressure type terminals for bare cables
- optional rear connections for bars or cable lugs

## compact CF CF 250



mastering electrical power



## accessories

- 1 SPDT auxiliary switch plus 1 SPDT alarm switch or
- 2 SPDT auxiliary switches
- shunt trip or
- undervoltage release (voltages available : 120, 240, 480, 600V AC 60 Hz, 12, 24, 48, 125V DC).
- 1 overcurrent trip switch (operates through trip unit and only when breaker trips)
- motor operator (voltages available : 120, 240V AC, 24, 48, 125V DC)

- padlocking device
- mechanical interlock between 2 breakers
- rotary operating handle (direct or door mounted)
- MCC type operating handle
- boot for handle
- label holder
- door escutcheon

## dimensions

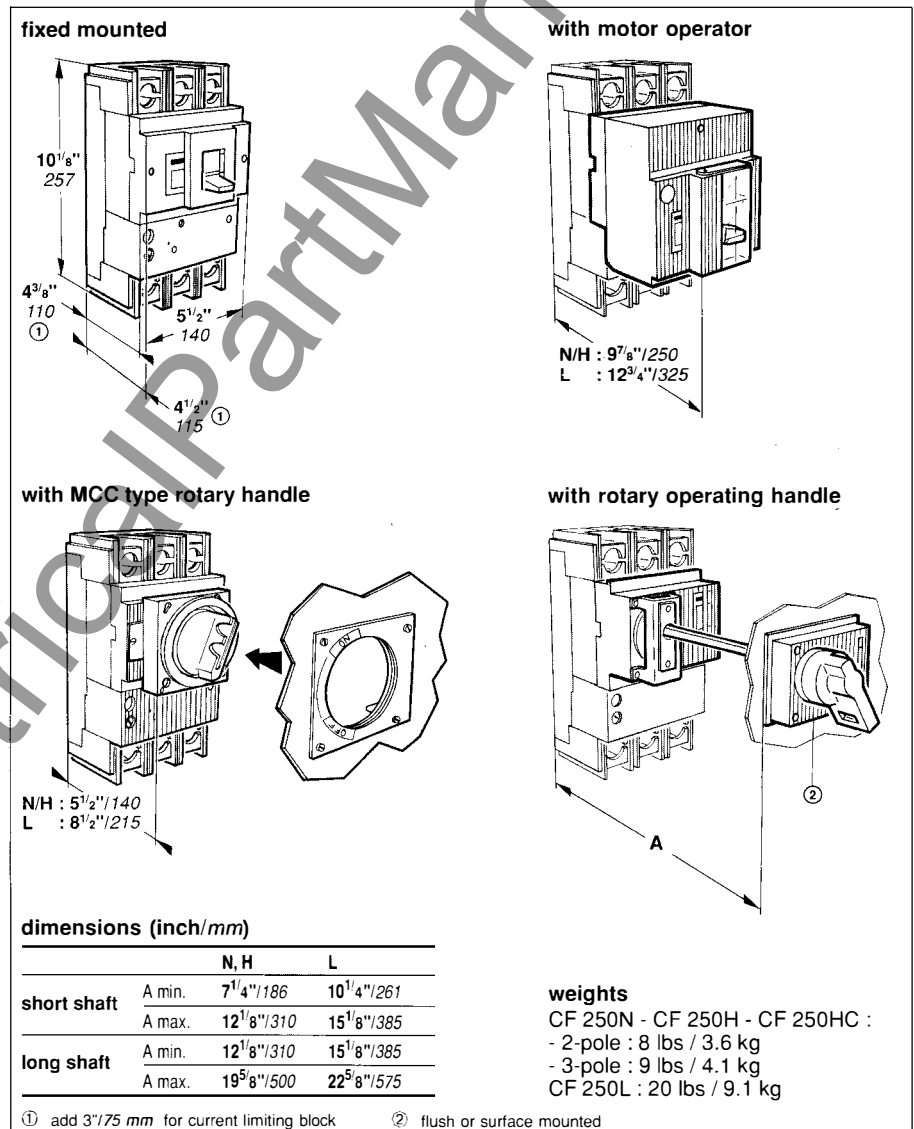

MERLIN GERIN CANADA LTD  
 L TEE  
 855 Matheson Blvd. East, Unit 14, Mississauga,  
 Ontario L4W 4L8  
 tel.: (416) 238-9025  
 fax: (416) 238-9028

1375 Graham Boucherville, Québec J4b 6A1  
 tel.: (514) 641-1340 Telex : 05-268734  
 fax: (514) 641-1472

**GROUPE SCHNEIDER**

VK19

MERLIN GERIN INC.  
 5000 Highlands Pkwy, Suite 150  
 SMYRNA, GA 30082, USA  
 tel.: (404) 432-2744  
 fax: (404) 432-9179

"As standard specifications and designs change from time to time, please ask for confirmation of the information given in the publication".

design by AMEG - DBTP - 05/90