

SIEMENS-ALLIS

Switchgear

INSTRUCTIONS

TYPES FB-500A1 7.2-kV AND

FC-500B 13.8-kV

**AIR MAGNETIC CIRCUIT BREAKERS
WITH STORED ENERGY OPERATOR**

TYPE 515-2

**18X10065
April, 1978**

INTRODUCTION

This instruction manual contains installation, operation and maintenance information for Types FB-500A 1 7.2-kv and FC-500B 13.8-kv stored energy operated air magnetic circuit breakers.

WARRANTY

The sales contract carries all information on warranty coverage.

RECEIVING

Circuit breakers are shipped from the factory completely assembled. Observe weight markings on crates and ensure that capable handling equipment is used.

Remove crating carefully with the correct tools. Check each item with the shipping manifest. If any shortage or damage is found, immediately call it to the attention of the local freight agent handling the shipment. Proper notation should be made by him on the freight bill. This prevents any controversy when claim is made and facilitates adjustment.

Use a spreader to prevent frame distortion and/or damage to arc chutes. Do not attach lifting hooks, rope, etc., to bushings, insulating parts, fittings, etc. Do not slide breaker off shipping skid without using ramp blocks provided as interlock plunger and linkage may be damaged.

STORAGE

Indoor - The circuit breaker should be installed as soon as possible. If storage is necessary, it should be kept in a clean dry place where it will not be exposed to dirt, corrosive atmospheres or mechanical abuse.

Outdoor - Outdoor storage of circuit breakers is not recommended. If breakers must be stored outdoors, they must be covered completely and a heat source provided to prevent condensation and subsequent corrosion.

If the circuit breaker must be stored for some time, "As Found" tests are desirable. (See page 19.)

CIRCUIT BREAKER PREPARATION

Prepare the circuit breaker for insertion into its cubicle as follows:

1. Remove Packaging. Note: Breakers are shipped in closed position with the trip rod and foot lever enclosed by packaging to prevent opening during shipment. (Refer to Fig. 1.)
2. Push manual trip rod to open breaker.
3. Remove phase barriers and unfasten both front and rear blowout coil connections. (See "Phase Barrier Assembly", page 11.)

4. With arc chute support in place at the rear of the breaker, tilt the arc chutes (refer to page 11 for details) to expose contact area.
 5. Remove dust, foreign particles, etc., from breaker.
 - 5A. Inspect ceramics for possible shipping damage.
 6. Check for mechanical freedom of disconnect arm movements by slowly closing the breaker. Reference page 15 for Slow Close Procedure.
 7. Trip breaker by depressing trip rod, Fig. 2, Item 43.
 8. Return arc chutes to upright position, fasten both front and rear blowout coil connections and replace phase barriers. Be sure screws on all phases are tightened securely.
 9. Install plug jumper and energize control. (Springs should charge.)
 10. Close breaker
 11. Trip breaker
- } with control switch on cubicle panel.
12. Depress foot lever and close electrically (*).
 13. Release foot lever and repeat steps 10 (#) and 11.
 14. De-energize control power and remove plug jumper.
 15. Coat movable primary and secondary disconnects with a film of A-C contact lubricant, 15-171-370-002.
 16. Insert breaker into its cubicle to "disconnect" position and close manually (*).
 17. Complete movement of breaker to "test" position and repeat steps (10 (#) and 11.
 18. Check for proper alignment between stationary and movable secondary contacts. Check for proper alignment between aux. switch bayonet on cubicle wall and operating fork on breaker.
 19. With line and bus de-energized, rack breaker into fully connected position. Close and trip breaker from main control panel. If bus or line are energized, get clearance before beginning this step.
 20. Lock out Kirk interlock (if provided) and repeat step 10 (*).
 21. Open interlock and repeat steps 10 (#) and 11.
 22. Breaker is now ready for normal operation.

(*) Breaker is trip free.

(#) Breaker will close.

CIRCUIT BREAKER DESCRIPTION

A typical circuit breaker consists of primary disconnect, arc chute, and operator sections. The primary disconnect section contains the main contact which supplies power to the load. The arc chute section dissipates the power arc energy drawn during the opening of the main contacts. The operator section contains the mechanism used to close and open the main contacts. This mechanism consists of a stored energy operator with its associated control circuitry.

ARC INTERRUPTION

Arc interruption is accomplished in free air at atmospheric pressure with the aid of a self-induced, magnetic blowout field and forced air draft. When the trip solenoid is energized, load current is being carried by the main contacts. As the contacts open, the main contacts part first and the current is transferred to the arcing contacts. When the arcing contacts part, an arc is established between them.

The arc between the arcing contacts is transferred to the arc runners as the arcing contacts open. The transfer of the arc to the arc runner establishes full current flow through the blowout coils, setting up a strong magnetic field. The magnetic field, accompanied by the natural thermal effects of the heated arc, tends to force the arc upward into the barrier stack. The large surfaces of the barrier stack cool and de-ionize the arc, while the V-shaped slots in the stack reduce its cross-section and elongate it, leading to rapid extinction. The arc runners are made of wide, heavy material for maximum heat dissipation and for minimum metal vaporization.

A puffer mechanism provides a forced air draft through the main contact area. This aids the magnetic blowout field and natural thermal effects in forcing the arc into the barrier stack for easy extinction.

OPERATOR

The breaker is closed by the stored energy operator straightening a toggle in the four-bar linkage (Fig. 7 Item 12). The operator is powered by precharged springs (stored energy).

Stored Energy Operator

The stored energy operator (Fig. 3) uses charged springs to power the closing operation. Opening is spring-powered also, but not with the same springs used for closing. A stored energy operator consists of three systems: spring charging drive, cam and ratchet assembly, and the four bar toggle linkage (Fig. 4, A - D). These systems are disengaged from each other except while performing their specific functions. For example - the spring charging drive and cam-ratchet assembly are disengaged except when the cam-ratchet arrangement is being charged. Similarly, the cam-ratchet and four bar linkage are free of each other except during closing.

Stored energy operated breakers normally require a single commercial relay for control. This relay is furnished to match the control voltage.

Reclosing Control (Optional – For Reclosing Applications Only)

The trip latch check system provides the necessary control to perform the reclosing function when the switchgear is equipped with reclosing relays.

The system is comprised of three elements; a magnetic actuator, a non-contacting magnetically operated hall effect switch (sensor) and a timer module. The system performs two distinct functions prior to enabling the reclosing operation.

1. It senses that the trip latch has returned to its reset position, and is ready to receive a reclosing operation.
2. Imposes a delay following latch reset to insure the linkage assembly has fully reset and then applies power to the spring release coil.

The non-contacting magnetically operated Hall effect switch and magnet actuator combine to perform proximity detection of the trip latch coil. The speed of operation and life expectancy of this proximity sensor system is not limited by mechanical actuation as no physical contact between the actuating magnet and Hall switch exist. The switch consists of a Hall sensor, trigger, and amplifier integrated on a silicon chip. Its complete encapsulation isolates the device from environmental effects.

AUXILIARY EQUIPMENT

Auxiliary Switch

Mounted on the breaker, the auxiliary switch is normally used to open the trip circuit when the circuit breaker is opened. As this multi-stage switch operates from the breaker disconnect blades, circuitry dependent on the position of the breaker, such as indicator lights, etc., is wired through this switch. The individual stages are easily converted to "a" or "b" without disassembling the switch (Figure 5).

Capacitor Trip Device

A capacitor trip device is commonly used with circuit breakers having an ac control supply installed in remote locations or unattended substations where battery cost and maintenance are undesirable.

In these cases, the capacity trip device may be charged from the same stepdown transformer that is used to energize the breaker control. This stepdown transformer should be connected to the LINE side of the breaker.

To apply the capacitor trip device to existing breakers originally shipped with dc trip coils, contact your Allis-Chalmers sales representative.

Trip Solenoid

Normal electrical tripping (opening) is caused by the trip solenoid (Fig. 8, 17) which is designated 52TC on the schematic of Fig. 9. The trip solenoid is energized by operation of the circuit breaker control switch and the protective relays which are mounted on the switchgear.

ARC CHUTE ASSEMBLY

Each arc chute (Fig. 6) consists of a frame retardant envelope which provides phase isolation for interruption and venting of the by-product gases of interruption. The arc chute contains -

1. The stationary end arc runner (4) and moving end arc runner (3) to which the arc terminals transfer from the arcing contacts. The arc runners form paths for the arc terminals to travel up the arc chute.
2. The stationary end blowout coil (15) and moving end blowout coil (13) which connect their respective arc runners to the top and bottom bushings. The current in these coils creates the magnetic flux which passes through cores (18), pole pieces (22) and the space between the pole pieces. The action of this flux on the arc forces the arc up the barrier stack.
3. The barrier stack (23) consisting of a number of refractory plates, with "V-shaped" slots, cemented together. The barrier stack cools, squeezes and stretches the arc to force a quick interruption.
4. The barrier (1) containing coolers (6) through which the by-product gases of interruption pass, completes the cooling and deionizing of the arc products.

Arc chutes can be tilted to expose contact area and for inspection of barrier stack (23). The arc chutes may also be lifted and removed for the breaker. Unfasten front and rear coil connections before tilting or removing arc chutes.

NOTE:

After arc chutes have been tilted back to their normal position, make sure that all screws have been replaced and tightened securely on all phases before phase barriers are replaced. Also ensure that blowout coils have been reconnected.

CIRCUIT BREAKER OPERATION

Normal -- Normal circuit breaker operation is controlled by cubicle mounted controls or other control devices. The closing springs of stored energy operated breakers will charge as soon as the breaker control is energized.

Opening Breaker -- Stored energy operated breakers can be tripped manually by depressing the trip rod (43), Fig. 2, or electrically by energizing the trip circuit. This rotates the latch that allows the closing linkage to collapse and reset.

Closing Breaker -- When the springs of a stored energy operated breaker are fully charged, it can be closed by pulling the manual close pull rod (21), Fig. 7, or electrically by energizing the closing circuit. This rotates the latch that allows the springs to close the breaker.

STORED ENERGY OPERATOR DESCRIPTION OF OPERATION

SPRING CHARGING CYCLE

Energization of the Breaker Control Circuit will cause the spring charging motor (1, Fig. 7) to start charging the closing springs (6, Fig. 3). The spring charging motor (1) will drive the driving pawl (2, Fig. 3) through an eccentric drive shaft (3, Fig. 3). The driving pawl (2) will turn the ratchet wheel (4, Fig. 3) counter-clockwise one tooth at a time. The holding pawl (5, Fig. 3) will hold the ratchet in position between driving strokes of driving pawl (2). This charging operation will continue turning the ratchet wheel (4) counter-clockwise a tooth at a time until the closing springs (6) are fully charged (dead center). The motor will drive the ratchet wheel past this dead center position and the closing springs (6) will aid rotation driving the ratchet wheel and cams counter-clockwise until spring release rollers (8, Fig. 8) on the inside surfaces of cams (7, Fig. 7) engage the spring release latch (9, Fig. 7). This arrests the motion of the ratchet wheel (4) and the cams (7) and holds the operator in the fully charged position. As the cams and ratchet wheel go over center, the motor cutoff switch (10, Fig. 3) is actuated to de-energize the spring charging motor (1). The spring charging motor then coasts to a stop, driving pawl (2) oscillating freely in the smooth toothless section of the ratchet wheel.

The motor cutoff switch (10) has four functions:

1. It de-energizes the spring charging motor (1);
2. It opens a contact in the anti-pump relay circuit;
3. It sets up the closing coil circuit;
4. It can be used to energize an indicating light to indicate that the closing springs (6) are fully charged.

NOTE:

The close latch check switch (16, Fig. 3) is in the motor circuit. The close latch check switch monitors the position of the close latch (9) and will prevent charging of the closing springs (6) electrically unless the close latch (9) is in the correct position.

As energy is stored in the closing springs, the four bar linkage (12, Fig. 7) will be positioned by the linkage reset spring (11, Fig. 8) which acts to cause cam follower rollers (14, Fig. 7) to follow the surface of cam (7, Fig. 7) until the links are in a reset position, and allowing latch rollers (20, Fig. 7) to be positioned in front of trip latch (18, Fig. 7).

See Fig. 4 for sequence of operation.

RECLOSING CONTROL (Optional – For Reclosing Applications Only)

The electronic solid state time delay module works in concert with the trip latch sensor system. The time delay module consists of an electronic timer and an electro-magnetic relay. The diagram, Figure 9, shows the timer module receiving power between terminals 1 and 3. Terminal 3 is connected to the common side of the closing control source. Terminal 1 is connected to the high side of the closing control source thru auxiliary contact (52B) and the closing source contact "CSC". The trip latch sensor system consists of the magnetic actuator and the Hall effect switch.

The time delay module is not energized until the breaker is charged, open and the closing source switch "CSC" is closed. With the latch reset at the instant "CSC" closes, the timer module's internal relay with normally open contact operates with no intentional delay (40ms electro-mechanical delay) to connect the spring release solenoid thru timer module terminal 2 to the high side of the closing source initiating the breakers closing sequence.

If at the time the closing source is applied, the trip latch is not reset, the timer module will assume a delaying mode of operation. Upon latch reset a predetermined delay will be imposed before the timer's relay closes energizing the spring release solenoid. The complete trip latch check system is not affected by broad variation of closing source voltage. The time delay error caused by temperature extremes of -40° to 65° C is a minus 3% to plus 5%.

BREAKER CLOSING CYCLE

Energizing the spring release solenoid (13, Fig. 7) will drive the close latch (9, Fig. 7) away from the spring release rollers (8, Fig. 8) on the cams (7, Fig. 7) releasing the stored energy in the closing springs (6, Fig. 7). The closing springs (6) will drive the ratchet wheel (4, Fig. 3) and the cams (7, Fig. 7) counter-clockwise at a high rate of speed. The cams (7) will engage the cam follower rollers (14, Fig. 7) of the four bar linkage (12, Fig. 7) and drive them forward causing the four bar linkage to become straight. As the four bar linkage (12) becomes straight, it drives the radius arm (15, Fig. 7) upward causing the breaker contacts to close and the opening springs to be charged. The cams (7) drive the four bar linkage (12) over toggle and against the frame thereby latching the breaker contacts in the closed position.

SPRING RECHARGE AFTER CLOSING

When the closing cycle has been initiated and the cams (7, Fig. 7) begin to turn, the motor cutoff switch (10, Fig. 3) resets itself. A "b" aux. switch of the breaker opens de-energizing the closing solenoid (13, Fig. 7). The close latch (9, Fig. 7) returns to its reset position and the close latch check switch (16, Fig. 3) closes and energizes the spring charging motor (1). The closing springs (6) are then recharged as described earlier.

TRIPPING CYCLE

Energizing the trip solenoid (17, Fig. 3) will drive the trip latch (18, Fig. 3) away from latch roller (20, Fig. 3) on the four bar linkage (12, Fig. 3). This allows the four bar linkage to collapse and the breaker contacts will open. If the closing springs (6) are in the charged position, the linkage reset spring (11, Fig. 8) will immediately reset the four bar linkage (12). If the closing springs (6) are not charged, the linkage reset spring (11) will not reset the four bar linkage (12) until just before the closing springs (6) are completely charged.

STORED ENERGY OPERATOR-COMPONENTS NOMENCLATURE

To be used with "Description of Operation" Figures 3, 7 and 8.

1. Spring Charging Motor
2. Driving Pawl
3. Eccentric Drive Shaft
4. Ratchet Wheel
5. Holding Pawl
6. Closing Springs
7. Cams
8. Spring Release Rollers
9. Close Latch
10. Motor Cutoff Switch
11. Linkage Reset Spring
12. Four Bar Linkage
13. Close Solenoid
14. Cam Follower Rollers (Main Toggle Roll)
15. Radius Arm
16. Close Latch Check Switch
17. Trip Solenoid
18. Trip Latch

20. Lotch Roller
21. Manual Close Pull Rod
22. Spring Discharge Roller Free Height Adjustment
23. Spring Discharge Close Lotch Yoke End Adjustment.
24. Spring Discharge Roller
25. Charge Discharge Indicator
26. Discharge Indication Adjustment
27. Charge Indication Adjustment
28. Mechanical Charging Interlock Adjustment
29. Manual Chorging Shaft and Gear Box
30. Anti-Pumping Relay
31. Trip Latch Bite Adjusting Screw
32. Trip Lotch Bite Adjusting Screw Locking Nut
33. Close Lotch Bite Adjusting Screw
34. Close Lotch Bite Adjusting Screw Locking Nut
35. Motor Cutoff Switch Actuator
36. Lower Link Stop
37. Roll Pin Striker
38. Aluminum Spring Drive Blocks
39. Spring Discharge Connecting Rod

*See Figs. 9 and 12 for Trip Latch Check System.

ELECTRICAL CONTROL

The normal control for this operator is contained in a control panel mounted at the rear of the unit. It consists of motor cutoff switch (10, Fig. 3), anti-pumping relay (30, Fig. 3), and the close latch check (16). The typical control arrangement's elementary diagram is shown in Fig. 9. (Check schematic furnished with switchgear as wiring arrangements may vary.)

Spring Charging

The spring charging motor power is supplied through terminals 3 and 4, Fig. 9. The mechanical interlock is a switch operated by the breaker release lever (foot lever) which opens the motor circuit when the lever is depressed. The close latch check switch is closed when the close latch (9, Fig. 3) is in the reset position. The 88 switches are shown with the closing springs discharged. When the control is energized, the motor starts to charge the springs. The 88 switch is operated by a roll pin striker (37, Fig. 3) mounted in the ratchet wheel (4, Figs. 3 and 14). As the ratchet wheel and drive blocks charge the springs, the ratchet wheel revolves to the position of full compression, dead center. Beyond dead center position, the springs aid rotation and cause the motor cutoff switch striker to depress the actuator (35, Fig. 3) of the 88-1 switch, opening the motor circuit and the 88-3 contact in the anti-pumping relay circuit. The spring charging motor coasts to a stop with the driving pawl (2, Fig. 3) oscillating freely on the smooth portion of the ratchet wheel.

Closing Circuit

The standard control circuit for a stored energy operator is shown in Fig. 9. When the close control switch is closed, the circuit from terminal 7 through 88-2 and 52Y1 to 52B through trip latch timer, Fig. 12 (when furnished), to terminal 6 energizes the closing coil, closing the breaker. As soon as the closing springs are discharged, and 88-3 switch contact closes to energize the 52Y relay. If the close control switch remains closed, the 52Y relay remains picked up through contact 52Y2. Control switch has to be released to reset control for another closing operation. This forms the anti-pumping relay circuit which prevents the circuit breaker from reclosing immediately after a trip free operation. If control power is momentarily lost during closing, upon re-energization, the 52Y relay picks up instantaneously through contact 88-3 maintaining the anti-pumping relay circuit prior to complete spring charging.

Close Latch – Mechanical and Electrical Interlocks

The close latch (9, Fig. 3) must be fully reset to receive the cam mounted spring release rollers at the end of the charging cycle. To insure the close latch is in this fully reset position, an electrical and mechanical interlock is provided.

The close latch check switch (16, Fig. 3 and 15) consists of snap-action type switch mounted in close proximity to the close latch. A striker plate at the tail of the close latch engages the switch's actuator slightly before the fully reset position is achieved and actuates the switch prior to the latches reaching the fully reset position. At the time of actuation, a contact closes initiating the charging sequence. The switch operates with very small differential, and this sensitivity coupled with the close latch biased engagement of the spring release rollers provides a positive sensitive interlock.

The mechanical interlock (Fig. 17) prevents manual charging of the breaker if the close latch is not adequately reset. A linkage attached by a clevis to the close latch, extends down the side of the breaker frame to the driving pawl mechanism. An extension of the interlock linkage passes above the driving pawl constant force return spring. If the close latch fails to return to a fully reset position, the linkage extension thrusts the driving pawl's return spring downward preventing the driving pawl's engagement of the ratchet wheel, thus mechanically inhibiting either manual or electrical spring charging.

www.ElectricalPartManuals.com

ADJUSTMENTS

Adjustments are factory set and checked before and after numerous mechanical operations on every breaker to insure correctness. No adjustment checking should be necessary on new breakers. If a malfunction occurs, check for hidden shipping damage.

The following will help you make the correct adjustments when replacing a broken or worn part.

CIRCUIT BREAKER TIMING

A comparison of circuit breaker timing at any period of maintenance with that taken when the breaker was new will indicate the operational condition of the breaker mechanism. A time variance of more than 1/2 cycle on opening and 2 cycles on closing indicates a maladjustment or friction buildup. A hole in the movable contact arm is provided for connection of a speed analyzer (item 29, Fig. 10).

PHASE BARRIER ASSEMBLY

Full height barriers of high dielectric flame retardant material isolate each phase (Fig. 2).

To remove phase barriers, remove screws (13), barrier (60) and channels (9) on rear of breaker. Lower panel (32) and loosen three screws (23). Remove three screws (24) and panel (22) on front of breaker. Phase barrier assemblies (5) may now be removed from the front of the breaker.

To return phase barriers to normal position, replace parts in reverse order. Make sure that barriers are seated properly and that channels (9) are located inside of washers (8).

TILTING ARC CHUTES

Remove phase barriers as described under "Phase Barriers Assembly." Refer to Fig. 2. Remove screws (1, 37) on each phase. Remove screw (39).

Position arc chute support at the rear of the breaker and tilt back the arc chutes as shown in Fig. 2A

After arc chutes are tilted back to their normal position, make sure all screws are tightened securely on all phases before phase barriers are replaced.

Note: MAKE SURE THAT BLOWOUT COILS HAVE BEEN RECONNECTED.

BARRIER STACKS

The barrier stacks (Fig. 6) are fragile and must be handled carefully. Inspect the barrier stacks for erosion of the plates in the areas of the slots. The barrier stacks should be replaced when a milky glaze appears on the full length of the edges of most of the slots. They should also be replaced if plates are broken or cracked. When cleaning the breaker and cubicle, inspect for pieces of barrier stack refractory material which would obviously indicate breakage.

To remove the barrier stacks, tilt back the arc chutes, remove four screws (26), two barriers (1) from each arc chute. Remove barrier assembly and slide barrier stack (23) through top of arc chute. When replacing barrier stack be sure the v-shaped slots go in first.

CONTACT PRESSURE OF DISCONNECT ARM HINGE JOINT

The hinge joint contact pressure is in proper adjustment when a pull of 2 to 4 pounds (0.91 - 1.82 kg) is required to move the disconnect toward the open position.

This measurement is obtained as follows: (Fig. 10)

Remove pin (46) and detach link (47) from the disconnect arms (18) and (19). Move the disconnect to a position just short of contact make. Attach a spring scale to the disconnect 10-1/2 inches (266.7 mm) above screw (24), and in a direction perpendicular to the longest edge of the disconnect arm. Measure the pull to move the disconnect toward the open position. Read scale while disconnect is moving through normal opening stroke.

Adjustment is made by tightening (or loosening) nut (14).

Before attaching link (47) to disconnect arms (18 and 19), check contact alignment and arcing contact lead (below and next page).

ARCING CONTACT HINGE JOINT

The arcing contact hinge joint (Fig. 10) is in proper adjustment when each spring washer (15) is deflected approximately 0.015 inches (0.4 mm).

This adjustment is obtained by tightening nut (4) until all parts just touch, then tighten the nut 3/4 to 1 turn more.

CONTACT ALIGNMENT AND REPLACEMENT

The main and arcing contacts are on integral part of the bushing assemblies and are carefully aligned with the upper and lower bushings before shipment. Normally, no further adjustment is necessary.

Use these procedures if it becomes necessary to change contacts or reset contact alignment (refer to Fig. 10).

Procedure A. Horizontal Alignment

1. Push stationary contact fingers as far back (tap with soft mallet) as they will go on stud (11, Fig. 10).
2. Using maintenance closing procedure, move the disconnect towards the closed position until it touches a main contact finger (view A-A, Main Contacts Engaging, Fig. 10). Dimension "C" should be no greater than .020 (0.51 mm) with one contact touching.
3. Adjustment is made by removing two nuts (100) and bumper assembly (101), loosening two nuts (22) and rotating the entire contact assembly. Check alignment (dimension "C") after nuts (22) are tightened. Install bumper (101) and nuts (100). Tighten securely.

4. Alignment is checked and adjusted on each phase separately. Be sure there is no binding between contacts (11) that could prevent wiping action with the disconnect arm.

Procedure B. Contact Penetration (Stroke) 10

1. Contact penetration should be checked and adjusted only when the contacts are properly aligned.
2. Check that open gap "d" is approximately correct to avoid over penetration (see Procedure D).
3. Using power closing procedures, close and latch breaker. The spread of the contacts (view "A-A", Breaker Latched) should be $1/8$ to $3/16$ inch (3.2 - 4.8 mm). This is the total of the two gap dimensions "a" measured on each side of the contact centering tube between the brass tube and the flat top surface on the contact. Each "a" dimension is normally $1/16$ to $3/32$ inch (1.6 - 2.4 mm).
4. With the breaker open, adjust by increasing or decreasing length of link (47) by turning nut (13). Adjust each phase separately.

Procedure C. Arcing Contact Lead 2

Arcing contacts are adjusted only after the main contacts have the proper alignment and penetration. The arcing contacts should make before the main contacts. To measure and adjust each phase:

1. Push stationary contacts back on stud.
2. Using the maintenance closing procedure, slowly move the disconnect arms toward the closed position until a dimension of $1/4" \pm 1/32$ (6.4 \pm 0.8 mm) can be measured between the lower stationary main fingers and the disconnect arms of the closest phase. (See fig. 10 dim. b view A-A arcing contact engaging.) The moving disconnect arms should be pushed back when making the measurement.
3. With the disconnect arms in proper position established in step 2, adjust nut (1) to have the moving arcing contact touch the stationary arcing contacts. (Push the moving arcing contact back when setting.)
4. Advance maintenance closing to obtain proper individual positions of the other phase disconnect arms in accordance with step 2 and set arcing contact lead in accordance with step 3. (Simultaneous touching of arcing contacts on all three phases is not required. Do not impair penetration of arcing contact lead setting in an attempt to optimize.)

Procedure D. Check Breaker Open Position 3

Dimension "d" (Breaker Open illustration of Fig. 10) is measured between the disconnect arm and the bottom of the second finger in the main contact assembly. The open position is determined by the setting of the rod end (40, Fig. 2) at the top of the puffer piston rod. The rod end (if set too low) can affect the trip latch roller clearance (Fig. 11). The optimum setting is to obtain the maximum open contact gap "d" while maintaining the specified trip latch roller clearance (see trip latch adjustment page 14). A dimension "d" of less than $5-11/16$ in. (144.5 mm) indicates improper adjustment.

AUXILIARY SWITCH

The type Q-10 auxiliary switch has been tested and adjusted at the factory. Contacts used in the breaker control circuit should not require further adjustment.

The switch (Fig. 5) is designed so that the individual contacts may be repositioned in fifteen degree steps without disassembling the switch.

Using long-nosed pliers, move the rotor contact (16) in the slot of the shell (14), compressing spring (15). This will free the rotor from the retainer (17). Rotate the rotor to the desired position and release. Be sure the rotor springs solidly back against the retainer to fully engage the rotor and retainer teeth.

INTERLOCK PLUNGER

The foot lever interlock release (20, Fig. 2) operates the interlock plunger (18, Fig 2) as well as the trip latch. Depressing the lever trips the breaker and raises the plunger. This frees the breaker so that it can be moved in its cubicle. The interlock system is in proper adjustment when the plunger is positioned 1-11/16 to 1-13/16 inch above the floor line, and causes tripping of breaker contacts when it is raised to a level not more than 2-1/16 inch above the floor line. The latch tripping rod associated with the foot lever should be clear of the trip latch (18, Fig. 3) by 1/32 to 1/16 inch in the relaxed position.

The foot lever can be padlocked by matching holes in the breaker frame with those in the lever arm. In the padlocked position, the foot lever will be halfway down; the breaker will be trip-free; the interlock plunger will be between 2 and 2-1/4 inches from the floor line and will hold the breaker in any of the three positions within the cubicle.

TRIP LATCH ADJUSTMENTS

Trip Latch Clearance Adjustment (Fig. 11) - this adjustment is to be performed after completing the arcing contact touch and main contact penetration adjustments referenced above.

This adjustment is necessary to insure proper clearance between the trip latch and trip latch rollers.

The puffer (or snubber) height adjustment will accomplish this purpose, and in no way will affect the penetration adjustment.

Loosen Lower Link Stop (36, Fig. 11) and rotate to permit maximum Lower Trip Link movement.

Adjust puffer (or snubber) (16, Fig. 2) height to rotate radius arm and four bar linkage until a .030" to .060" gap appears between the latch and latch roller. Lock in place. Rotate Lower Link Stop until it touches lower link and lock in place. Recheck dimension "d" as described in procedure D, page 13.

Trip Latch Bite Adjustment - trip latch bite is established by setting the latch tail top surface 5/16" below surface of self clinching nut as shown in Fig. 12-(A). Lock securely with jam nut. One turn of adjusting screw will alter the gap 0.062 inches. This adjustment will produce a latch bite of approximately 1/8" - 1/4" as shown in Fig. 12-(C).

030-060
60-28432 Feeler Gauge

$$\frac{19}{64} - \frac{31}{64} \leftarrow \frac{5}{16} \pm \frac{1}{64}$$

TRIP LATCH CHECK SENSOR ADJUSTMENTS (FIGURE 12(B) AND 12(D))

This adjustment is to be completed only after establishing the "bite" adjustment described above.

The magnetically operated Hall effect switch (sensor) and actuating magnet are to be preassembled to the operator. The unit can be adjusted by advancing the threaded bushing through the tapped hole in shelf until a gap of .040 – .000 + .015 inches is achieved between the surface of the switch and the top of the shrink tubing holding the magnet actuator assembly to the trip latch. With this gap achieved, the sensor may be locked in place.

Functional electrical test on breaker may be made to confirm sensors operation. The timing modules nameplate and rated voltage should be checked to insure it matches breaker closing control voltage. The timers delay adjustment has been previously set and should not be altered. Remove wire from terminal 2 on timer module and insulate. Open breaker and charge opening springs.

Apply closing voltage and observe light emitting diode (led) adjacent to delay adjustment. The led should be brightly illuminated when the trip latch is fully reset. Depress latch with manual trip lever and observe the led goes out. Release trip lever and the led should come on. This sequence confirms sensors operation. Do not apply closing control voltage for longer than two minutes while performing this test.

MANUAL CHARGING OF CLOSING SPRINGS

To charge the closing springs manually, disconnect control power before inserting the manual charging crank in the socket located in the center of the left hand operator panel. Turn the crank in a counter-clockwise direction to charge the springs. The effort to charge the closing springs will fluctuate and will increase to a peak and then decrease. At the point of least effort an audible click will be heard and the effort to turn the crank will drop to near zero. The mechanism is now fully charged. Remove manual charging crank. The breaker may be closed by pulling the manual close pull rod.

CAUTION!!

MAINTAIN A FIRM GRIP ON CRANK

The closing springs are charged through the driving pawl and ratchet wheel and are thereby indexed by the holding pawl. Some springback can occur between tooth positions on the ratchet wheel.

MAINTENANCE SLOW CLOSE

With the breaker removed from the cubicle, manually charge the closing springs as previously described and remove charging handle. Then, from the rear or stud side of the breaker, attach the spring blocking device, Fig. 13, by fastening it in the slots in the closing spring tubes.

Stay clear of the breaker contacts and pull the manual close pull rod at the front of the breaker. This will discharge the closing springs against the spring blocking device during which the breaker contacts will move slightly toward the closed position.

Place the manual spring charging crank back in the socket at the lower left corner of the breaker. By turning the crank counter-clockwise the breaker contacts may be slowly closed for checking contact alignment.

CAUTION

MAINTAIN A FIRM GRIP ON CRANK

As the contacts will close in increments predicated by the teeth on the ratchet wheel, spring-back will occur between tooth positions.

REMOVAL OF SPRING BLOCKING DEVICE

To remove the closing spring blocking device, Fig. 13, the closing spring must be fully charged. The spring may be charged manually by inserting the charging crank and continuing counter-clockwise rotation. The main contacts will go fully closed as the four bar linkage toggles. Upon continued rotation, the closing springs will be picked-up as noted by increased effort in cranking. Continue rotation until the springs are fully charged. A sharp click will be heard as the spring release rollers engage the close latch indicating full spring charge has been achieved. The spring blocking device may now be easily removed by pulling the blocking portion from the slots in the spring tubes.

REMOVAL OF CLOSING SPRINGS

The closing springs may be quickly and safely removed from the breaker. Remove two of the four bolts holding the spring bearing block at the rear of the breaker. These bolts should be diagonally opposite each other. Insert studs approximately 6" long in place of bolts. Remove the remaining two bolts by shifting the spring lead to the 6" long studs. The spring bearing block can then be backed off by alternating backing off the studs. To install the power spring the reverse procedure should be used. The spring bearing block top surface should be even with the bracket of the frame. The four bolts should be torqued to 50 ft. lbs.

If the charging ratchet and cams are to be revolved with springs removed, it is advisable to remove two aluminum spring drive blocks (Item 38, Fig. 8) secured to the ratchet and cam crankpins by retaining rings. These pins if not removed or held essentially in a horizontal position may jam while revolving the cam and ratchet assembly.

Motor Cutoff Switch - The 88 motor control switch assembly (Fig. 14) is factory adjusted. If it should become inoperative, entire unit must be removed and inspected for contact wear. Replacement may be necessary.

Motor Cutoff Switch Adjustment - This adjustment is most conveniently performed before installing the charging springs.

Advance ratchet and cam assemblies to position shown (Fig. 14). The holding pawl must occupy the ninth (9) tooth position on the ratchet as counted counter-clockwise from area on ratchet periphery which lacks two teeth.

With ratchet in the position described above, adjust the motor cutoff switch vertically until its actuator makes positive contact with the rollpin striker. Lock switch assembly in this position.

Check lateral movement of actuator. Lateral play at end of actuator (tip) should be no more than 1/16" max. If adjustment is necessary, snug pivot screw to just bind actuator, and then back off 1/16 to 1/8 turn. Rotate ratchet and cam assembly to insure actuator rides in gap between ratchet and cam without striking or binding.

Close Latch Bite Adjustment - free jam nut and place latch in horizontal position (Fig. 15). Visual accuracy. Measure "D" directly above latch pivot. Reproduce this dimension plus 0.062" at the latch face as shown in the figure above by rotating the adjustment screw. Secure jam nut. This adjustment should produce a latch bite of 0.151 to 0.216 inches. Springs 5

Close Latch Check Switch Adjustment (Fig. 15) - This adjustment is to be performed only after completing the latch bite adjustment described above. Spring Check 6
Breaker open

A clearly audible "click" should be heard from the switch as latch is moved 1/32" from latch adjustment screw. The latch switch actuator may be bent slightly to obtain switch operation at this point. Maximum permissible bend is 1/8" as shown.

If switch actuator is bent, observe latch fully closed against adjusting screw and make certain the switch actuator has not contacted the switch body. A 1/64" clearance should exist as shown above.

Free Height Adjustment (Fig. 16) - is achieved by blocking the actuating roller to the indicated height and adjusting a pair of jam nuts, located on the manual closing pull rod, to maintain the roller in this position with blocking removed. Return spring adjusting nut should be set to produce 0.5 ± .06 inch deflection in return spring. 7

The following adjustments are to be made only after completing the close latch bite adjustment described on the previous page and after adjusting connecting link as shown on Fig. 16.

Trip adjustment (Fig. 16) is made by varying the penetration of the "curved actuating rod" in its attachment clevis. A 1/4" (.250) drill is placed between the upper latch surface and the latch adjusting bolt. A 2.906" block is to be inserted between the actuating roller and floor. The "curved" rod's upper yoke is nested against a forward roll pin in the closing latch and the lower clevis is adjusted to insure the closing latch will not move more than 1/16 (.062) inches as measured between adjusting screw and latch surface when the 1/4" (.250") drill is removed. 8

Overtrovel (Fig. 16) - no adjustment required. Check with 3.125" blocking below actuating roller. Closing solenoid link should provide freedom of latch movement without jamming.

Close Latch Mechanical Interlock (Fig. 17) - this adjustment is to be undertaken only after completing the close latch bite adjustment described above. Fig. 15. 9

Adjust actuator rod displacement from support angle to 1.06 ± .015 inches. See detail of adjusting nut "A" (Fig. 17). 1/64 - 1/64

Insert 1/4 (.250) drill between upper surface of close latch and latch adjustment screw.

Check guide bushings to insure they stand off the frame $1/4$ " as shown.

Free Nut "B" below attachment clevis, and adjust Nuts "B" and "C" to depress pawl return spring and pawl until $1/16$ to $3/32$ clearance is obtained between tip of pawl and ratchet teeth. This clearance is measured during the clockwise rotation of the pawl as its tip is toward the ratchet (power stroke). 062-093

The pawl must be rotated using a $1/2$ " square insert in the eccentric drive shaft or by low voltage (slow rotation) of drive motor or manual charging.

Return the jam nut "C" attachment clevis to bottom an bracket, and tighten external jam nut "B" securely. MAINTAIN CLEVIS PARALLEL TO FRAME.

Remove $1/4$ " (.250) drill, restoring latch to its normal position. Again rotate eccentric drive shaft. The tip of the drive pawl should engage the full face of each ratchet tooth with a clearance of $.030$ " between the base of the tooth and the engaged tip of the drive pawl.

MAINTENANCE AND TESTING

General

Thorough, periodic inspection is important to satisfactory operation. Inspection and maintenance frequency depends on installation, site, weather and atmospheric conditions, experience of operating personnel and special operation requirements. Because of this, a well-planned and effective maintenance program depends largely on experience and practice.

ALWAYS INSPECT A BREAKER WHICH HAS INTERRUPTED HEAVY FAULT CURRENT. All contacts, arc runners and arc chutes should be examined to determine if repair or replacement of parts is required. Inspect for pieces of barrier stack refractory material in the cubicle as well as the circuit breaker.

"As Found" Tests

Some users perform "As Found" insulation tests using a megger or Doble testing to give an "As Found" value for future comparative indication of insulation change. This is desirable for new circuit breakers if they are to be stored for extended periods, and may absorb moisture and contaminants. Contact resistance tests can also be made using a ductor.

Since wide variations can occur in insulation values and contact resistance because of atmospheric conditions, contamination and test equipment, discrete values cannot be given. However, making and recording these tests on new equipment, and at regular intervals will give a comparative indication of insulation and/or contact resistance change. Maintaining a permanent record of these values for each circuit breaker should be part of the Maintenance Program.

Periodic Inspection and Maintenance

Prior to performing any maintenance work, make certain all control circuits are open, and that the breaker has been completely withdrawn from the metal-clad unit.

CAUTION

DO NOT WORK ON THE BREAKER OR OPERATING MECHANISM WHILE THE BREAKER IS IN THE CLOSED POSITION. DO NOT WORK ON THE BREAKER OR OPERATOR WHILE THE CLOSING SPRINGS ARE CHARGED.

1. Remove interphase barriers (Refer to Page 11, Phase Barrier Assembly) and clean them and all other insulating surfaces with dry compressed air – a vacuum cleaner, or clean lint free rags. Inspect for signs of corona, tracking or thermal damage.
2. Tilt the arc chutes to expose the main contacts. (Refer to Page 11, Tilting Arc Chutes).
3. **Contacts** ♦

Examine the contacts, Fig. 10. The major function of the air circuit breaker depends upon correct operation of its contacts. These circuit breakers have two distinct sets of contacts – main and arcing – on each pole. When closed, practically the entire load current passes through the main

contacts. If the resistance of these contacts becomes high, they will overheat. Increased contact resistance can be caused by pitted contact surfaces, corrosion of contact surfaces, or weakened contact spring pressure. This will cause excessive current to be diverted through the arcing contacts, with consequent overheating and burning. Verify proper main contact pressure by checking penetration (Refer to Page 13, Procedure B).

Arcing contacts are the last to open, and arcing originates on them. In circuit interruption, they carry current only momentarily, but that current may be equal to the interrupting rating of the breaker. In closing against a short circuit, they are the first to close and may momentarily carry considerably more than the short circuit interrupting rating. Therefore, they must make contact prior to the main contacts. If not, the main contacts can be badly burned.

On the magnetic blow-out air circuit breaker, the arc is quickly removed from the arcing contacts by magnetic forces and transferred to arc runners in the arc chute (Fig. 6.) The arcing contacts are expendable and may eventually burn enough to require replacement.

The main and arcing contacts are made of tungsten alloy to resist deterioration due to arcing. If the surfaces are only roughened or slightly pitted, they can be smoothed with crocus cloth or draw filed. Be careful not to remove much material, as this would shorten the contact life. If significant erosion has occurred, the arcing contact lead must be checked and adjusted using Procedure C on Page 13.

If they are badly pitted or burned, they should be replaced. (Refer to Page 12).

The main contacts may be lubricated per Fig. 20, but DO NOT LUBRICATE THE ARCING CONTACTS.

4. Disconnect Arm Hinge Joint

Check contact pressure of the disconnect arm hinge joint per Page 12. If the pull is within the 2 to 4 pound (0.91 - 1.82 kg) acceptable range, the joint should be satisfactory. If not, then it should be maintained as follows:

Refer to Fig. 10. Remove disconnect arms as a unit by removing screw (24), nut (14) and spring washer (23). Carefully inspect all contact surfaces in hinge joint. Replace any damaged parts. Silver washer (25) and adjacent surfaces should be clean and free of roughness or galling. However, discoloration of the silvered surfaces is not usually harmful unless caused by sulfide (insulating) deposits. These should be removed with alcohol or a silver cleaner. Lubricate silver washer and mating surfaces by applying electrical contact lubricant (Fig. 20, J). Reassemble hinge joint. Tighten screw (24) and nut (14). Spring washer (23) and silver washer (25) must be assembled in their original position to assure proper adjustment. Adjust per Page 12, "Contact Pressure of Disconnect Arm Hinge Joint and Arcing Contact Hinge Joint".

5. Arc Chutes

Inspect the arc chutes. This includes inspection of the ceramic parts (barrier stack and flash plates) for breakage, erosion and dirt; inspection of the blowout coil insulation; and of the entire arc chute for dirt, moisture or contaminants which might affect insulation strength.

Dirt or contaminants may be removed from the barrier stack with a cloth, by light sanding or by scraping with the end of a file. Wire brushing or emery cloth is not approved because metallic particles may become embedded in the insulating material.

Arc flash plates in the lower portion of the arc chute may be cleaned by sand blasting or by sanding with coarse grain paper, to remove glaze and metal deposits from the surface.

Blow out particles with dry compressed air.

Small cracks or pieces chipped or broken from ceramic parts may be ignored. A barrier stack split vertically along a rope seam may be repaired with epoxy cement. A barrier stack split horizontally or one with several broken plates should be replaced.

The action of the arc on ceramic causes slight melting. Small milky glass nodules on the edges and surfaces of the ceramic barrier stack plates are normal after interruption. With severity and number of operations, this melting and glazing increases. When barriers are heavily glazed (milky white along the edges of the V slots) the barrier stacks should be replaced.

Blowout coil and core insulation should be inspected for evidence of abrasion, heating or mechanical stress which could lead to electrical discharge between coil and core.

Mechanically damaged, burned or punctured blowout coils and core insulation should be repaired or replaced.

6. Mechanism – Stored Energy Operator

The circuit breaker mechanism should be inspected at 2000 operation intervals. This inspection should check for loose hardware and any broken parts. The control wiring should be checked for loose connections and frayed or damaged insulation. The "spring release latch check switch", "trip latch check system" (if furnished), and "mechanical interlock" switch should be checked for mounting tightness. The satisfactory operation of each switch element should be assured with a continuity meter and manual manipulation of the switching element, and adjusted if necessary. Verify that operation of "Close Latch Mechanical Interlock" is proper (Refer to Page 17 and Fig. 17).

After 10,000 operations, the operating mechanism should be given a general overhaul and all worn parts replaced. Excessive wear will usually be indicated when adjustments can no longer be satisfactorily made. The general overhaul will require disassembly of the operating mechanism. All bearings and surfaces receiving wear should be examined carefully and re-lubricated in accordance with lubrication instructions which follow.

The removal of the closing springs will be necessary in order to permit overhaul of the breaker. These springs may be removed as described on Page 16.

7. Lubrication

NOTE: The lubricant supplied with the accessories is intended to be used exclusively on the contacts and must not be used on any part of the circuit breaker mechanism.

Recommended circuit breaker lubrication points are shown in Fig. 18 and 19. The chart (Fig. 20) outlines two methods of lubrication. Refer to this chart for recommended lubricant and points of application. The first method requires no disassembly and is suggested for the prevention of problems which could be created by severe environmental or operating conditions. The second method follows procedures similar to those performed on the breaker at the factory. Follow this procedure only in case of a general overhaul or disassembly.

Needle and roller bearings are factory lubricated for life and should not require attention. However, the best of greases are affected by time and atmospheric conditions and may require service.

To lubricate these bearings when parts are disassembled, the following procedure is recommended. Clean in solvent, wash in alcohol, spin in light machine oil, drain and repack with Beacon P-325 grease. DO NOT REMOVE NEEDLE BEARINGS FROM THE RETAINING PART.

8. Air Puffers

Air puffers (E, Fig. 19) are important to the interruption process because they provide a flow of air which assists in controlling the shape of the arc column at low current values. This control causes the arc to make an earlier transfer to the arc runners, thereby energizing the magnetic circuit which drives the arc into the barrier stack. This action produces a shorter arcing time than would be possible by relying only on the thermal effects of the arc to achieve the transfer to the arc runners.

Puffers should be inspected during regular breaker maintenance periods. Hoses should be checked for flexibility, freedom from kinking or collapse and soundness of connection to mating parts. Cylinders should be checked for cleanliness and freedom from deposits which might retard the motion of the piston. Pistons should be checked for free movement within the cylinder and that the seals are flexible and contact the walls of the cylinder. Transformer oil is used on felt seals to keep the material pliable, reduce shrinkage and to provide lubrication. The oil should moisten but not saturate the felt.

Replace seal material if it becomes inflexible or does not make contact with the cylinder walls.

The air output from the puffer nozzle may be checked with the arc chutes tilted (refer to "Tilting Arc Chutes", Page 11 and Fig. 2A). Crush a 4-1/2 x 4-1/2 inch sheet of tissue paper, place it in the nozzle opening and check to see that it is dislodged when the breaker is opened.

9. Inspect for foreign objects which may have been left in the circuit breaker during previous steps. Check for loose hardware.
10. Check for mechanical freedom of disconnect arm movements by slowly closing the breaker. Reference Page 15 for "Maintenance Slow Close" Procedure.
11. Trip breaker by depressing trip rod. Fig. 2, Item 43.
12. Return arc chutes to upright position, fasten both front and rear blowout coil connections and replace phase barriers. Be sure screws on all phases are tightened securely.

13. "As Left" Tests

- a. Insulation resistance tests should be made to verify the insulation integrity. These can include megger or Dobel tests. If possible, a high-potential test should be made for one minute at values shown below. With the breaker open, check each phase across the open contacts by connecting from the upper to the lower primary disconnects. With the circuit breaker closed, check phase-to-phase and each phase-to-ground.

	HI-POT. TEST KV	
	AC	DC
FB-500A1	14.3	20.2
FC-500B	27.0	38.2

- b. A dielectric test on secondary and control circuits should be made at 1200 volts.
 - c. If desired, contact resistance tests can be made using a Ductor.
 - d. Make a permanent record of all tests performed.
 - e. Compare with prior tests. (See "As Found" Tests on Page 19).
14. Inspect the primary disconnect contact finger assemblies, Fig. 2 (3).

The main contact surfaces should be clean and bright. However, discoloration of the silvered surfaces is not usually harmful unless caused by sulfide (insulating) deposits. These should be removed with alcohol or a silver cleaner. Slight impressions on the contacts will be caused by the pressure and wiping action of the contacts. Minor burrs or pitting can be allowed and projecting burrs may be removed by dressing. Nothing more abrasive than crocus cloth should be used on the silvered contact surfaces. Where serious overheating is indicated by discoloration of metal and surrounding insulation, the contacts and spring assemblies should be replaced. In this case, also investigate the cubicle mounted stationary disconnects, (with the switchgear de-energized) determine the cause of overheating, and take corrective action.

15. Prepare the circuit breaker for service by repeating steps 9 through 22 on Page 2.

HANDLING INSTRUCTIONS

- Move breaker to installation location with fork lift or crane (A).
- Carefully remove protective plastic cover or crate.
- Remove ramp pieces nailed to the pallet at the front of the breaker (B).
- Remove hold down bolts located on each side of breaker (C).
- Place ramp pieces in front of the pallet in line with breaker wheels and nail to pallet as shown by arrows in (D).
- Slowly roll breaker off pallet (E & F).

CAUTION – REMOVE PACKAGING. BREAKERS ARE SHIPPED IN CLOSED POSITION WITH THE TRIP ROD AND FOOT LEVER ENCLOSED BY PACKAGING TO PREVENT OPENING DURING SHIPMENT.

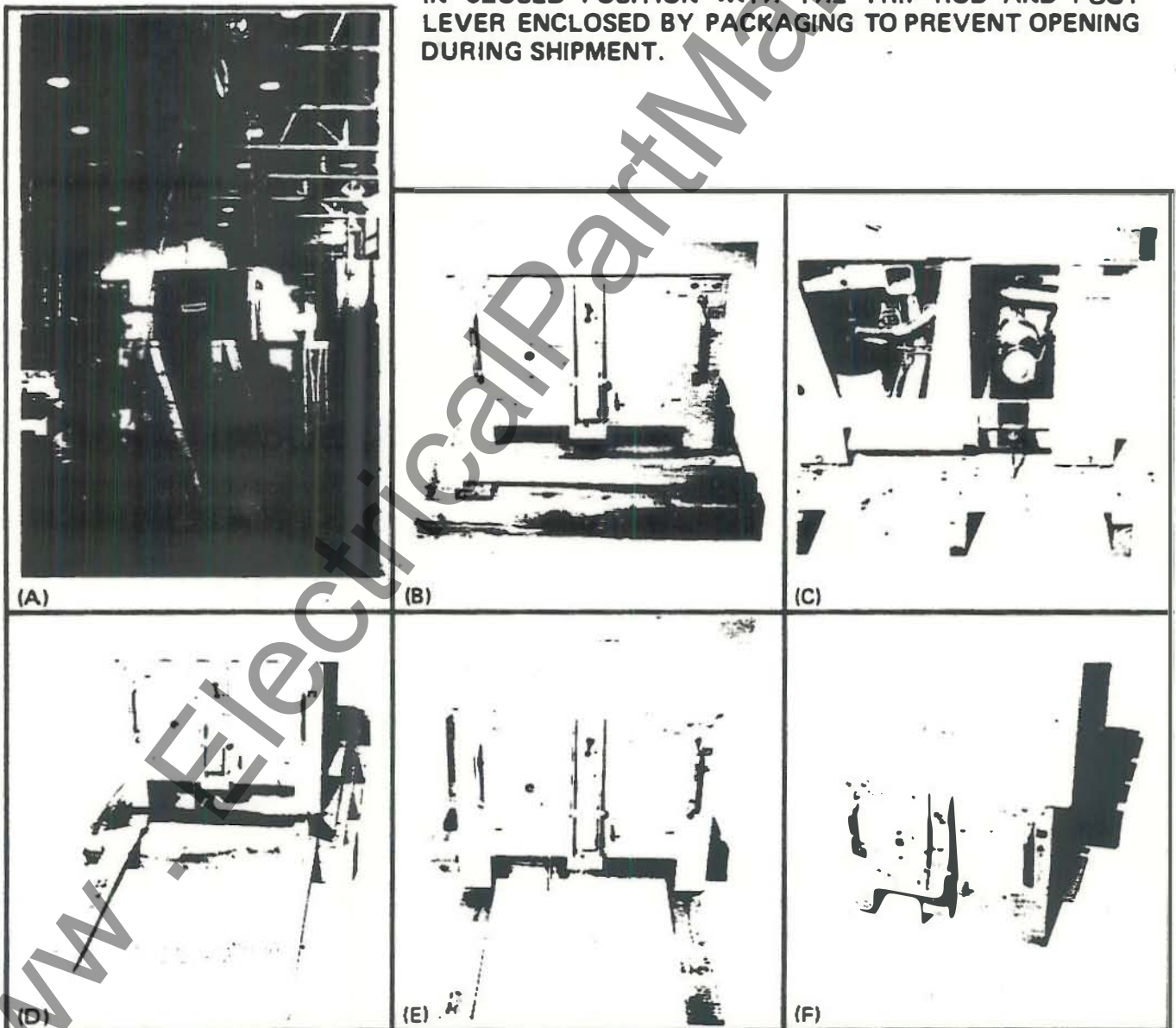
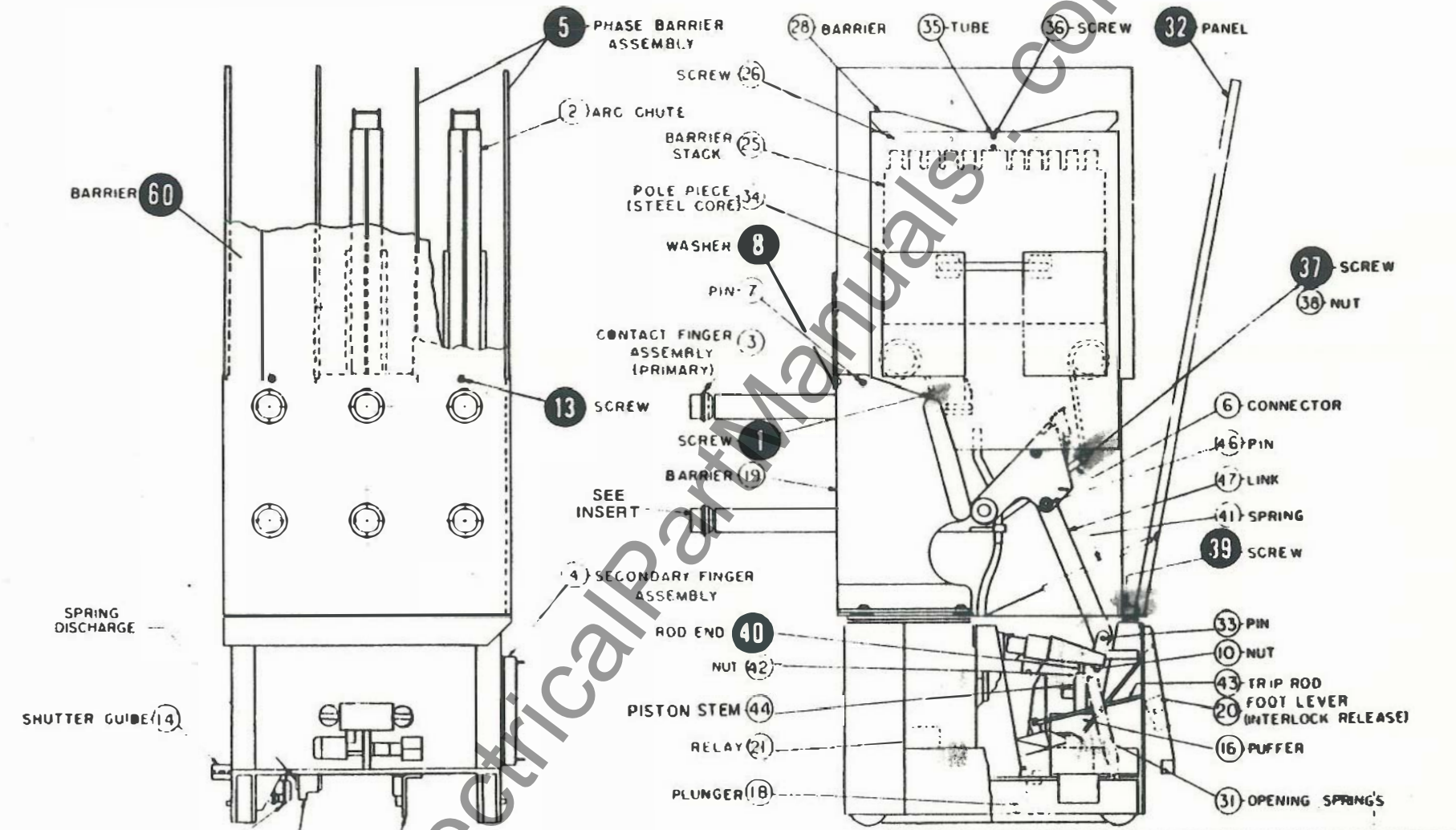

Fig. 1 – Circuit Breaker Handling Instructions



FC-500A-1, FB-500A-1

NOTE
 BE SURE THAT THE SMALL BRASS SPACER WASHER IS INSTALLED NEXT TO CUP INSERT IN CONTACT ASSEMBLY TO ALLOW FOR FLOATING ACTION OF ASSEMBLY. THIS IS REQUIRED AS PART OF SELF ALIGNING FEATURE.

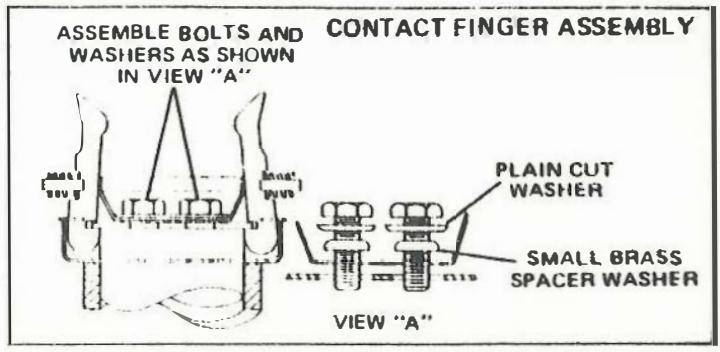

Fig 2 - Typical Circuit Breaker Assemblies



Fig. 2A Arc Chute Support in Position

WARNING: DO NOT ATTEMPT TO MOVE BREAKER WHILE IN THIS CONDITION.

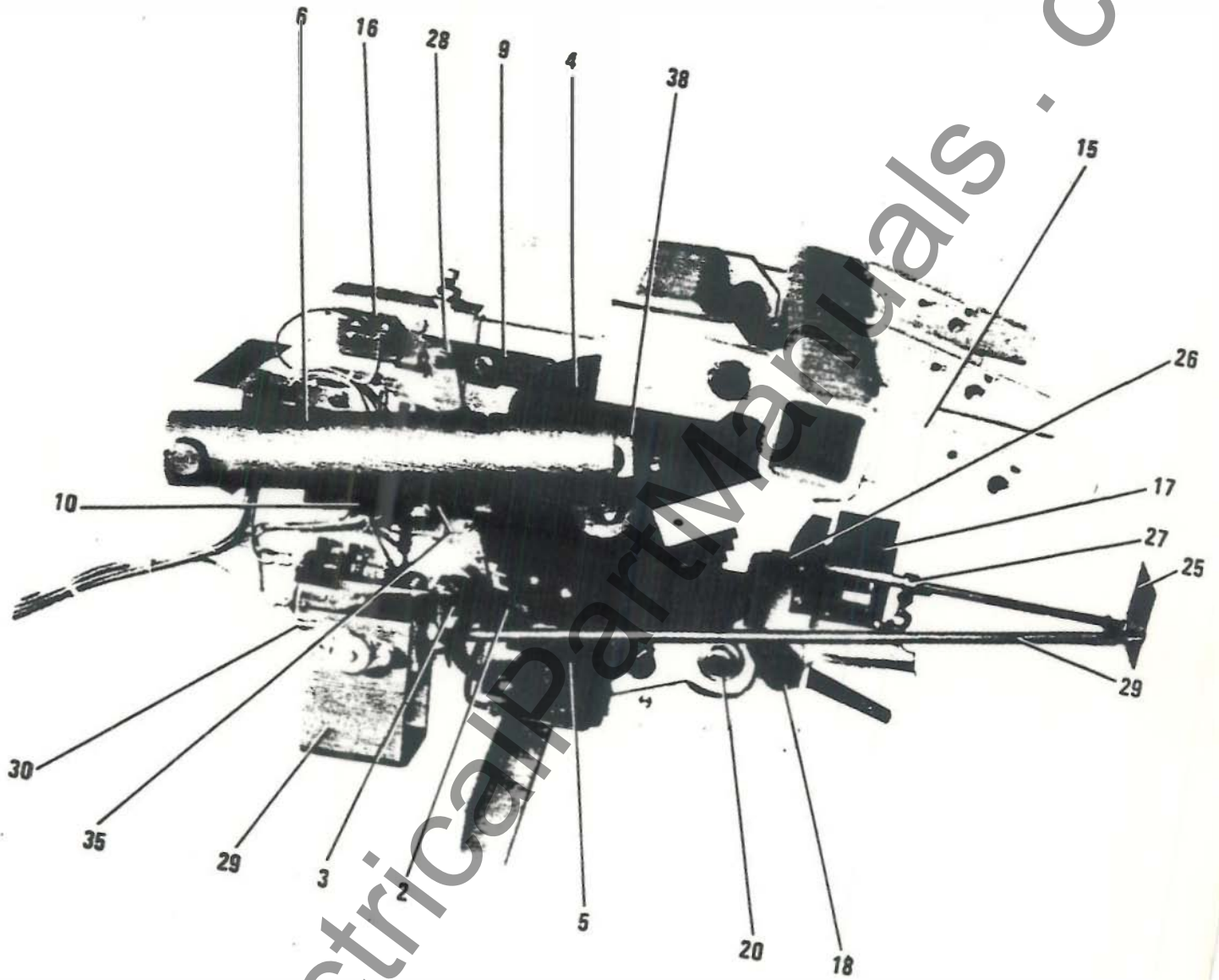
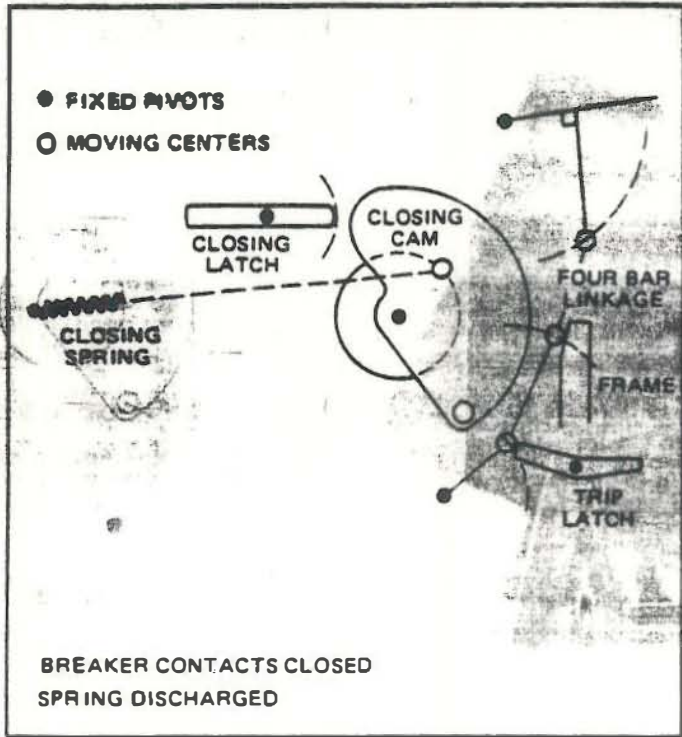
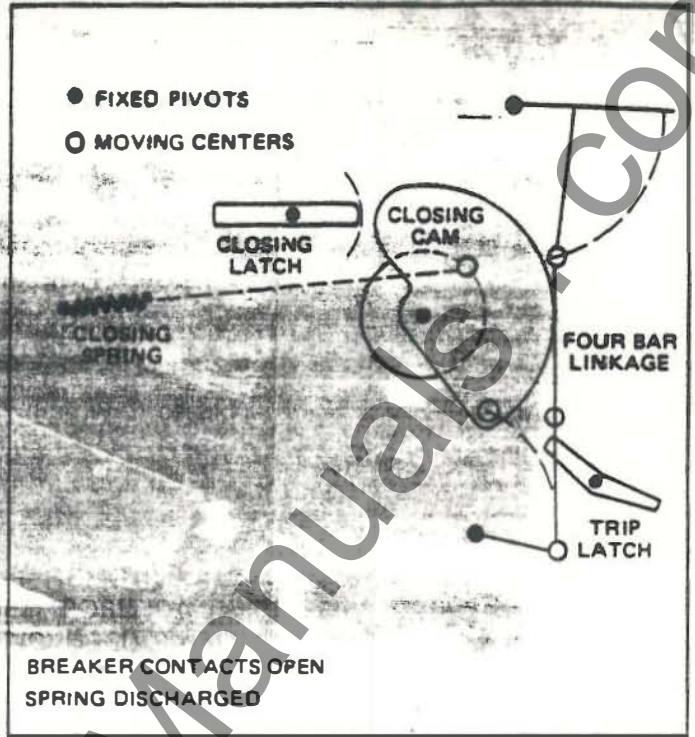

Fig. 3 515-2 Operator L.H. View



-A-



-B-

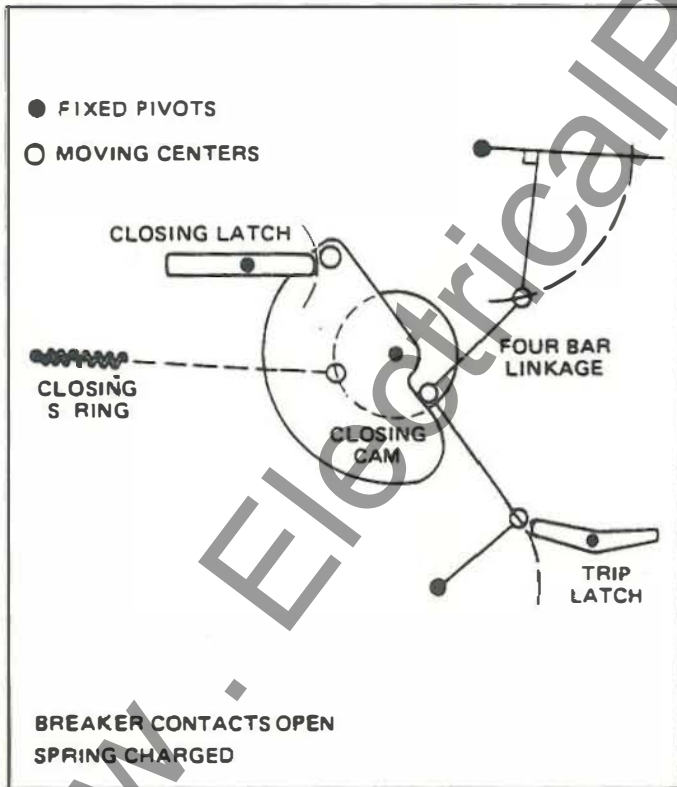

-C-

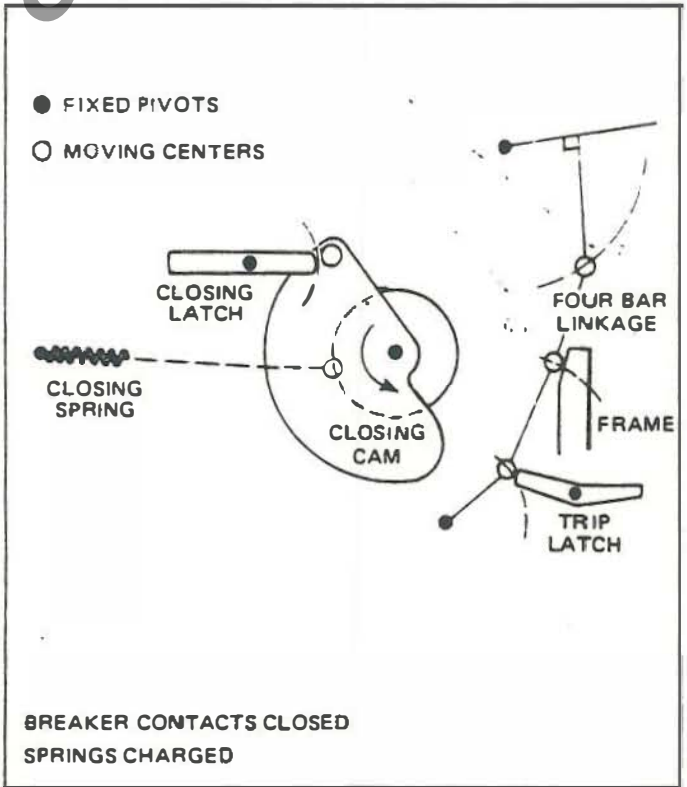

-D-

Fig. 4 - Sequence of Operation

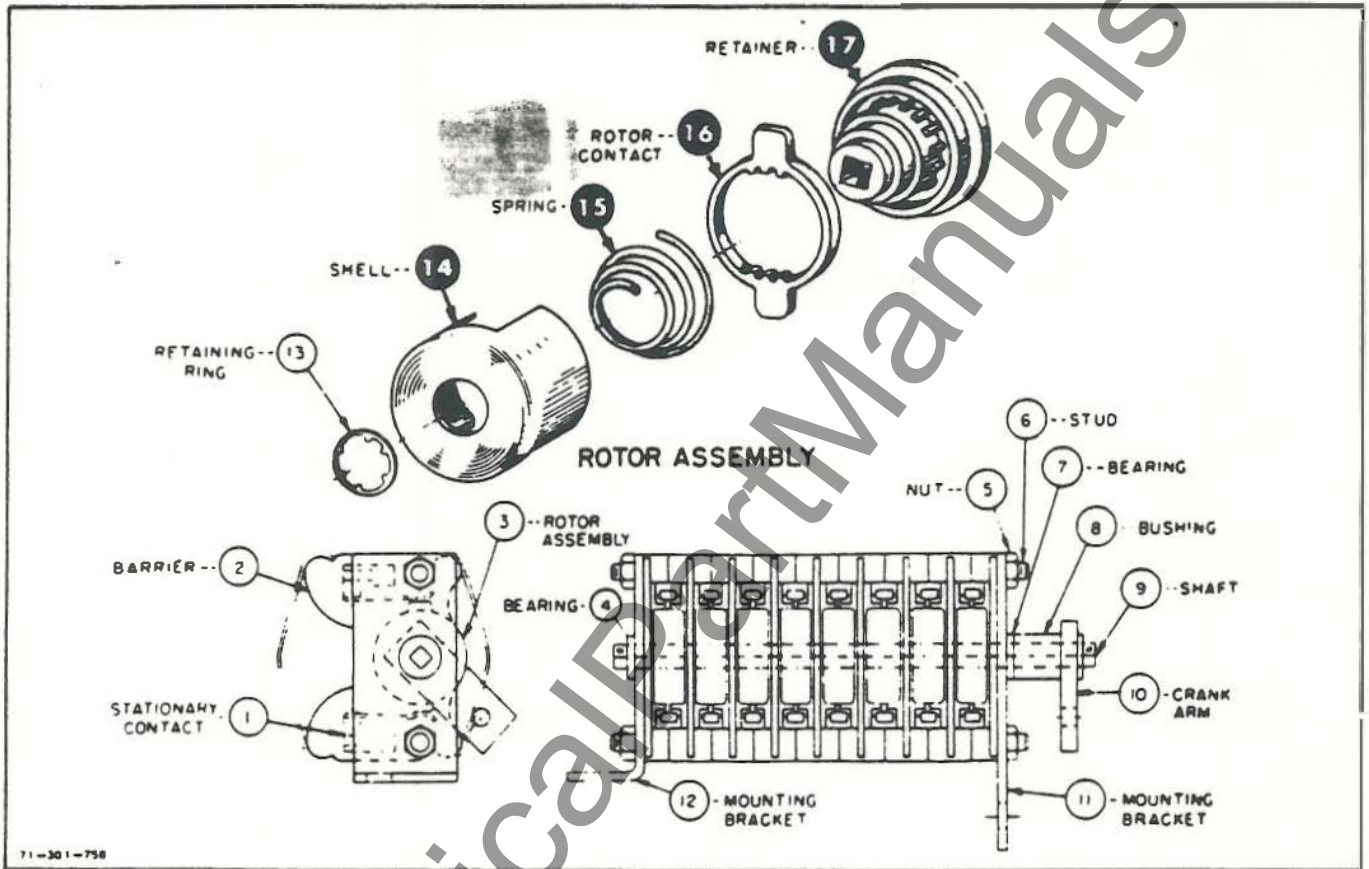
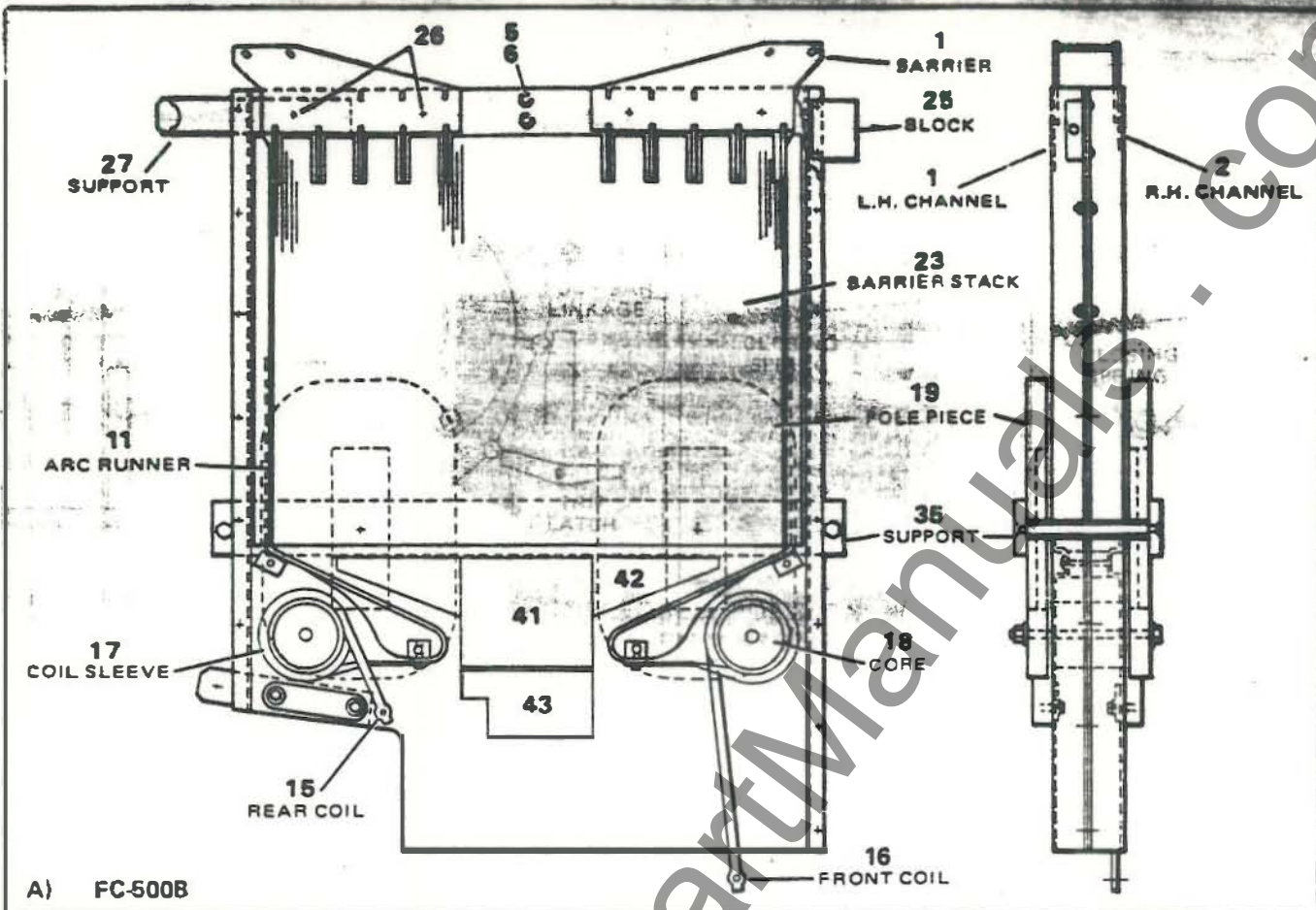

Fig. 5 - Type Q-10 Auxiliary Switch



71-401-532-401

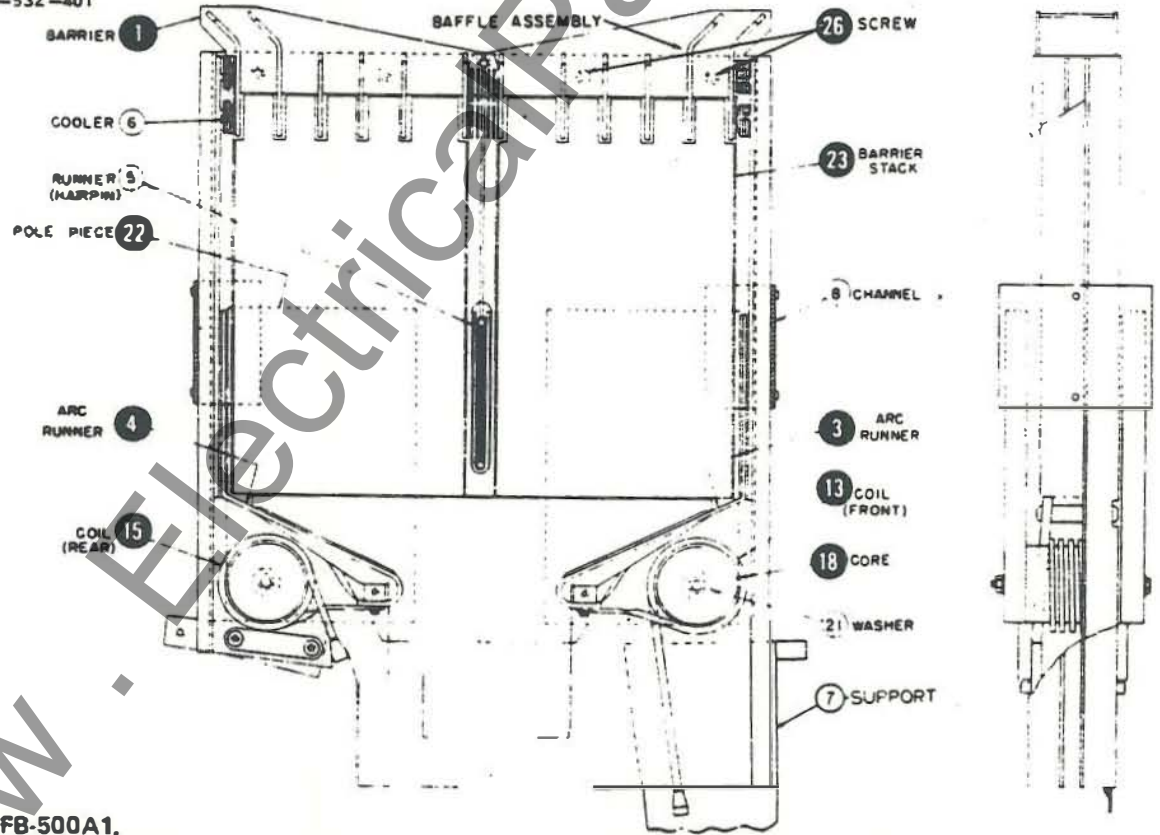

Fig.6 - Arc Chutes

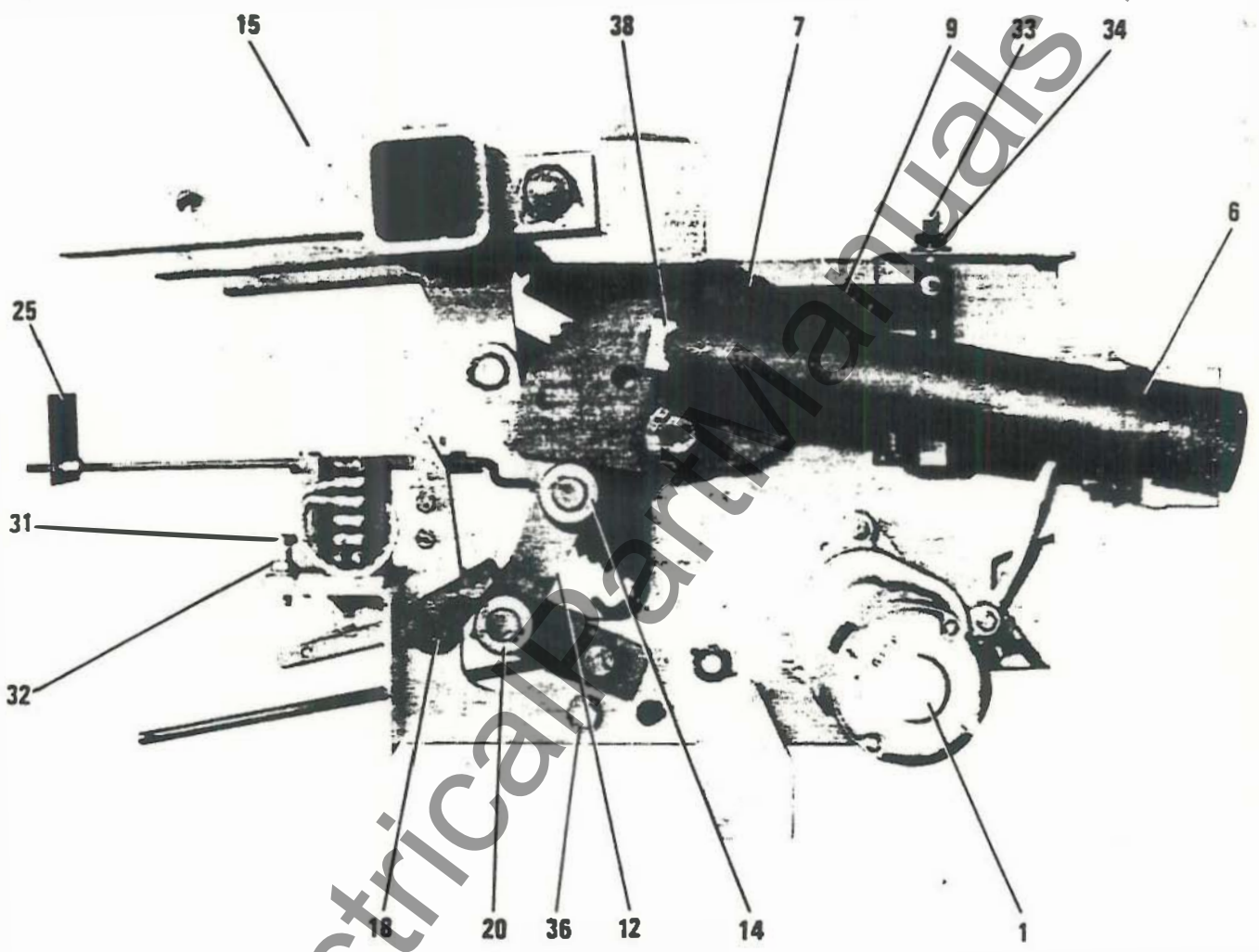

Fig. 7 515-2 Operator R.H. View

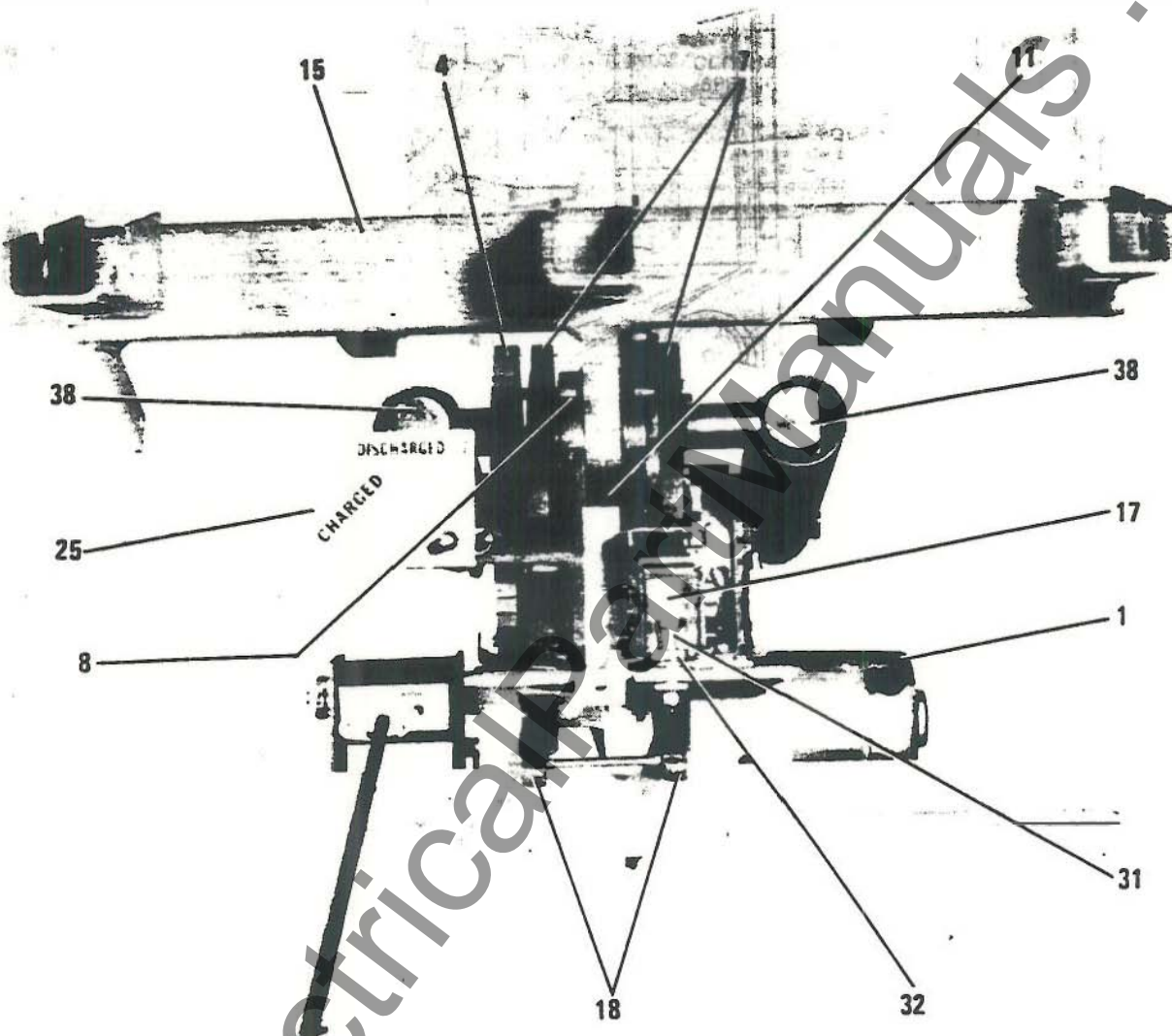
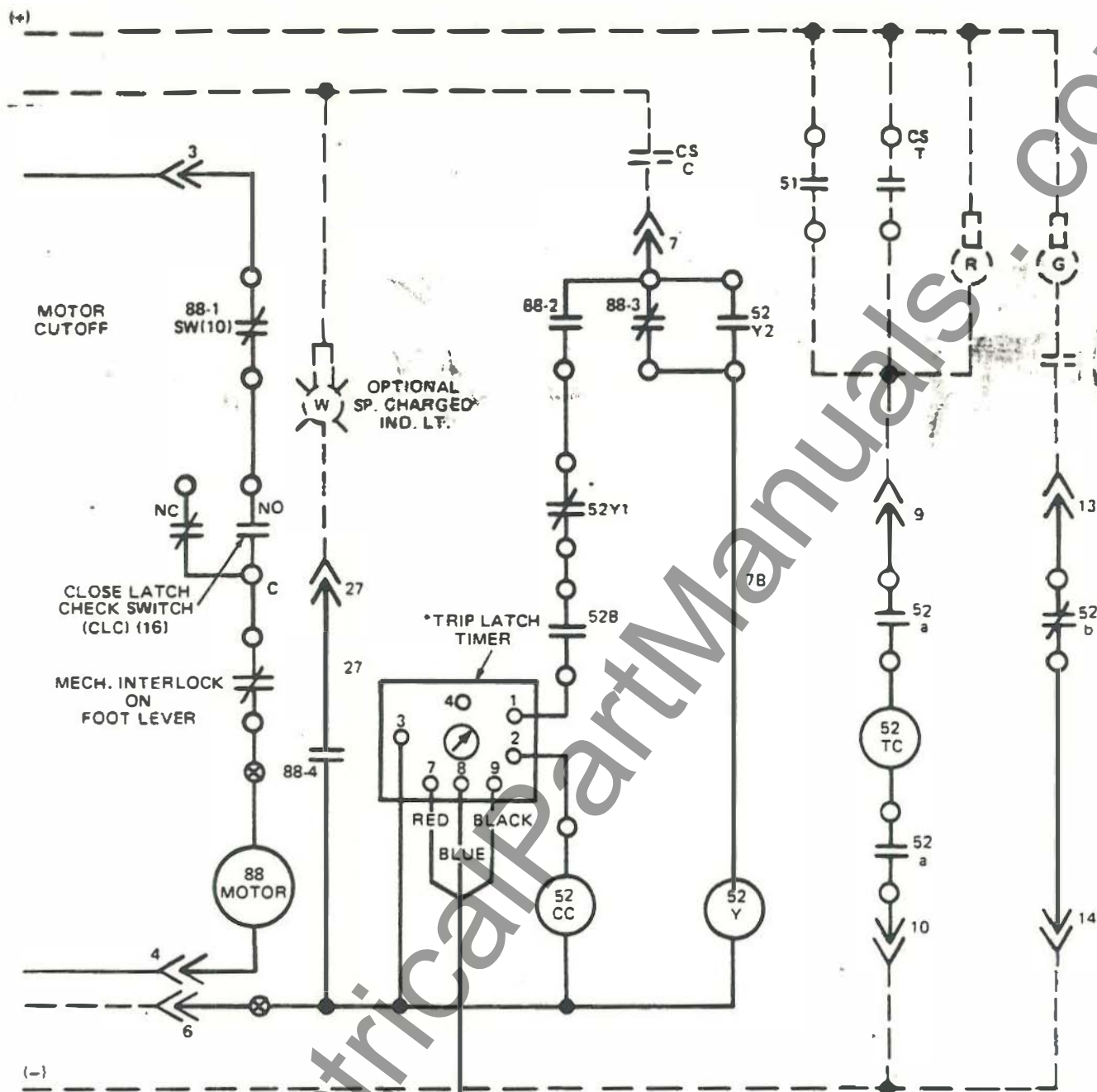

Fig. 8 515-2 Operator Front View



- 52 TC - CIRCUIT BREAKER TRIP COIL
- 52 CC - CIRCUIT BREAKER CLOSING COIL
- 52 Y - AUX. CLOSING RELAY ANTI PUMP
- MCO - MOTOR CUTOFF SWITCH
- 88 - SPRING CHARGING MOTOR
- CLC - CLOSE LATCH CHECK SWITCH
- TLC - TRIP LATCH CHECK SWITCH
- CSC - CONTROL SWITCH - CLOSE CONTACT
- CST - CONTROL SWITCH - TRIP CONTACT
- R - RED INDICATING LAMP
- G - GREEN INDICATING LAMP
- a - AUX. SWITCH - OPEN WHEN BR'KR. IS OPEN
- b - AUX. SWITCH - CLOSED WHEN BR.KR. IS OPEN
- * - OPTIONAL ITEMS FOR RECLOSING APPLICATIONS ONLY

Fig. 9 - Control Scheme for Stored Energy Operator

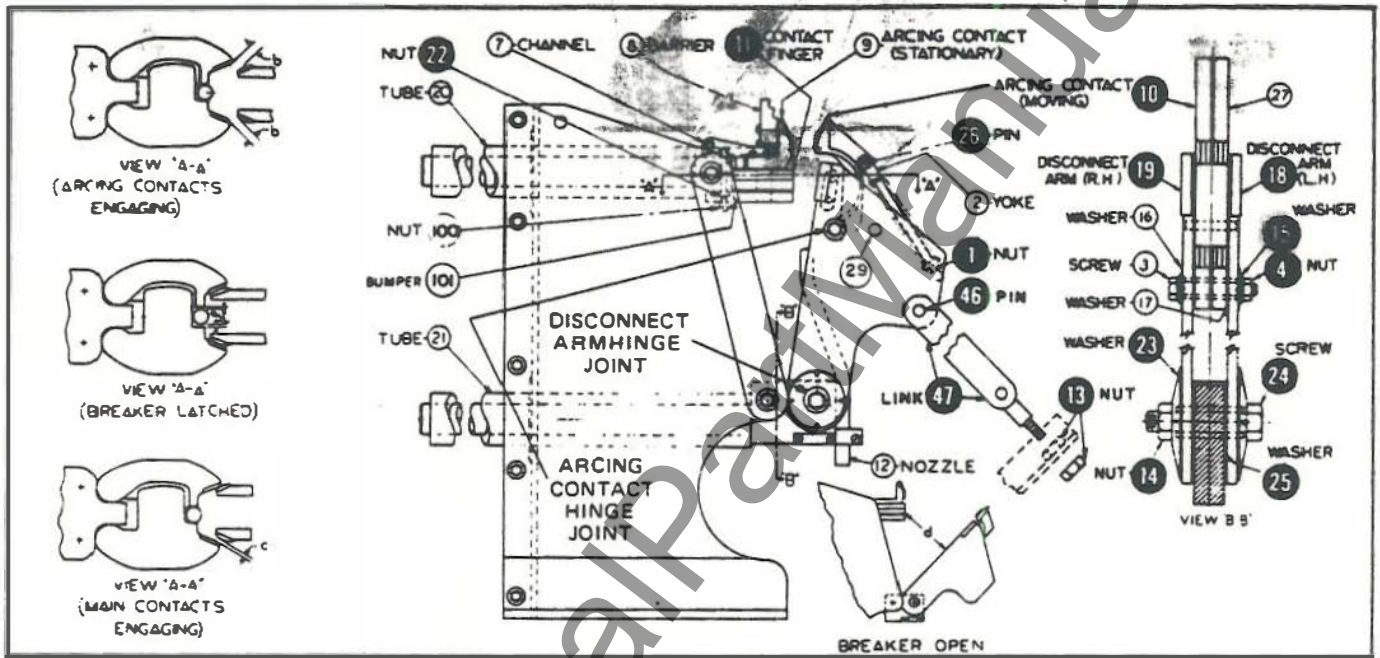

Fig. 10 — Stud and Support Assembly

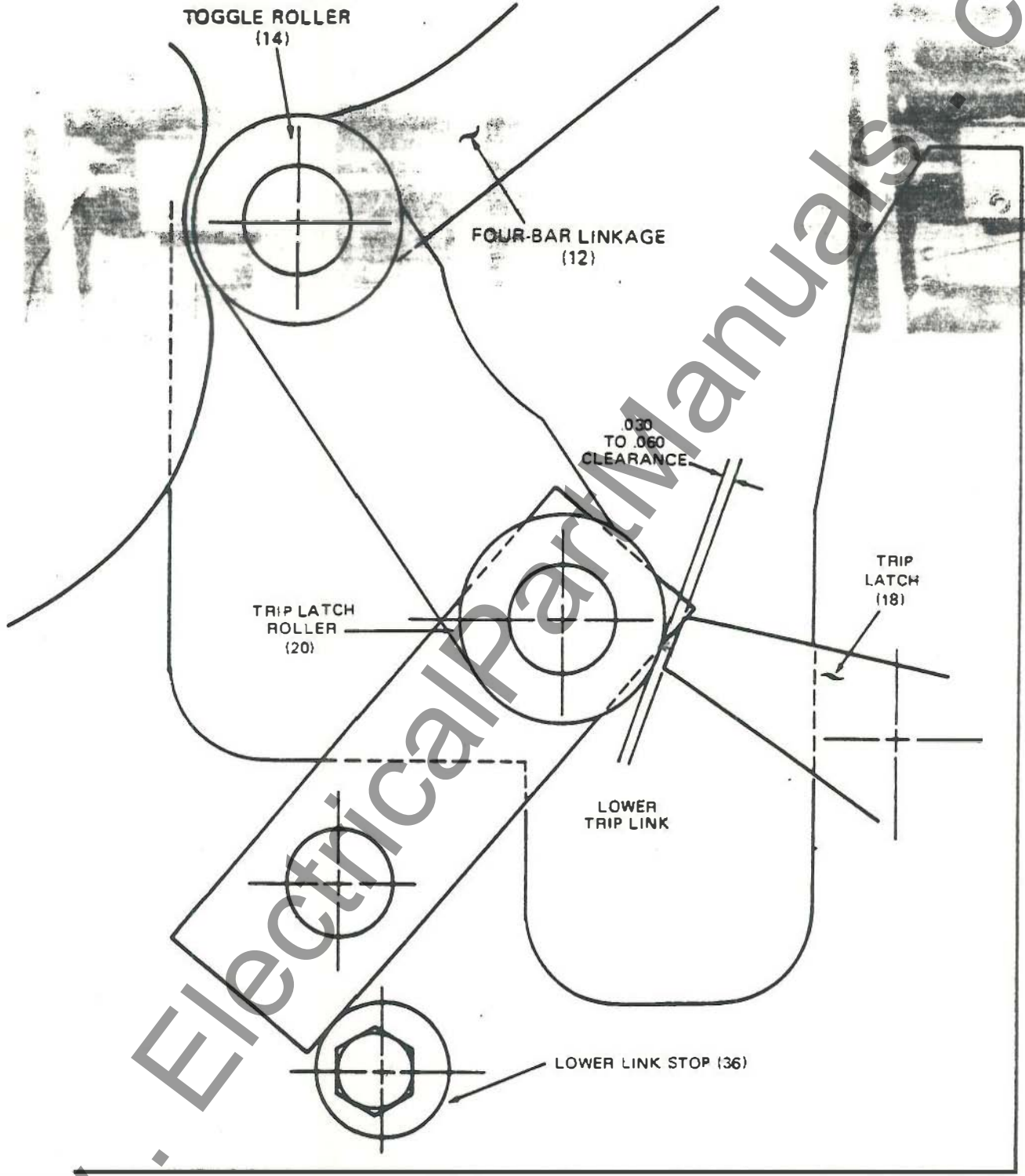
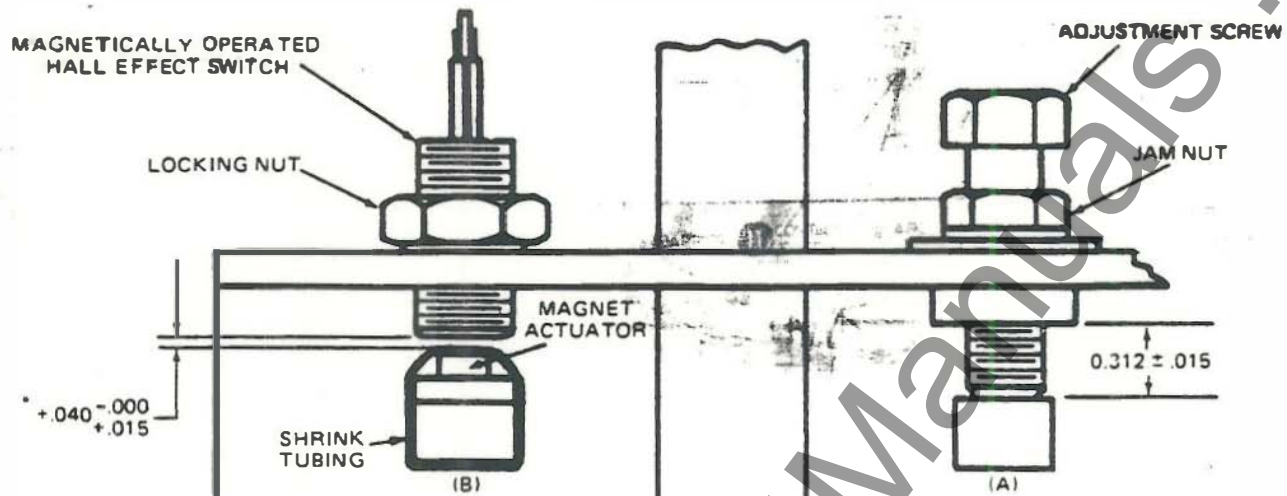

Fig. 11 - Trip Latch Clearance Adjustment



*THIS DIMENSION MUST BE BETWEEN HALL EFFECT SWITCH BASE AND TOP OF SHRINK TUBING AS SHOWN.

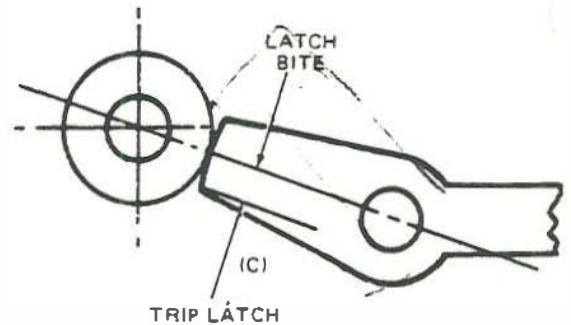
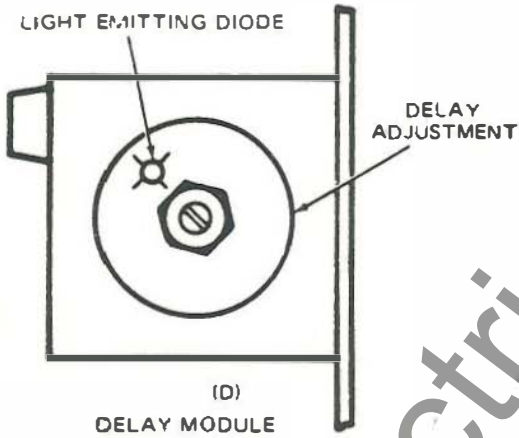
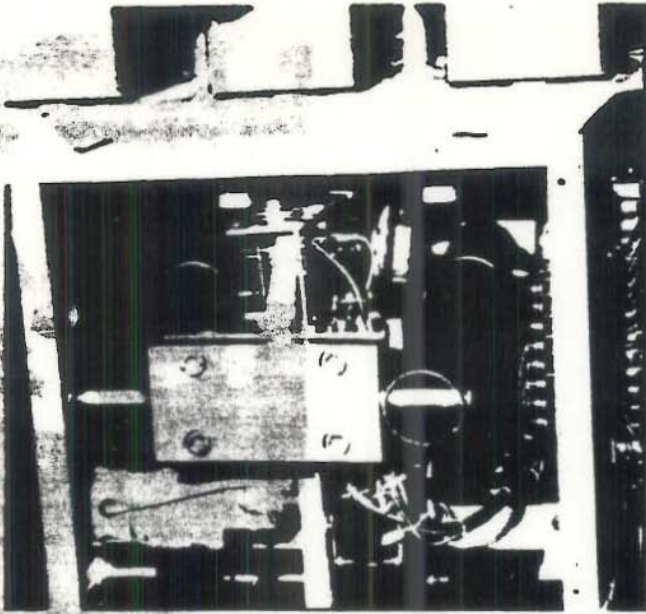
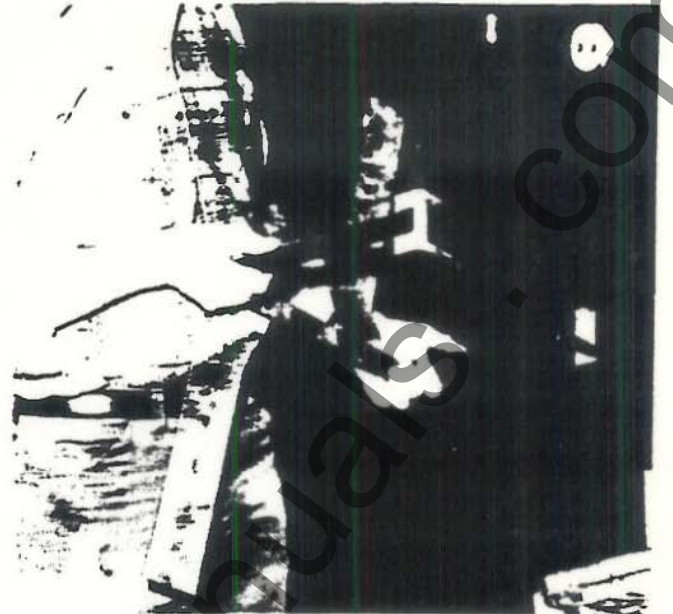

Fig. 12 - Trip Latch Bite and Check Switch Adjustments



340064

BREAKER CHARGED AND READY TO RECEIVE SPRING BLOCKING DEVICE:



340063

SPRING BLOCKING DEVICE IN CORRECT POSITION FOR INSERTION

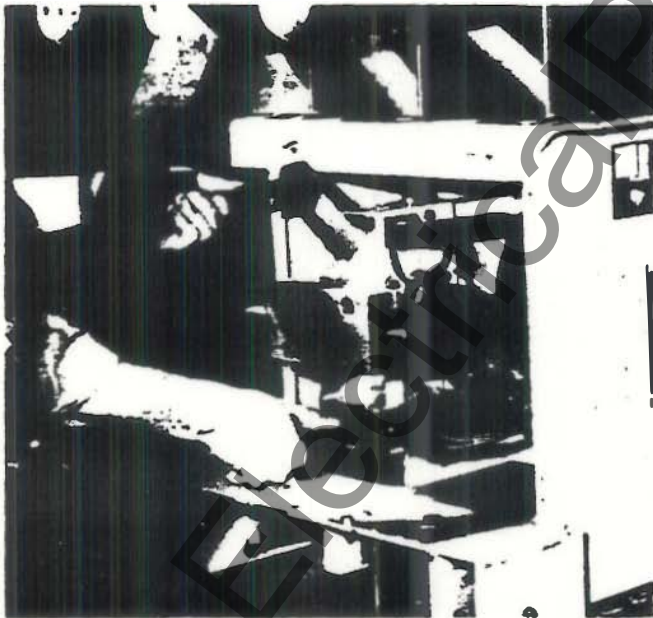

340065

INSERTION OF THE SPRING BLOCKING DEVICE. NOTE: SPRING BLOCKING DEVICE MUST BE DIAGONALLY INSERTED TO CLEAR BREAKER FRAME.

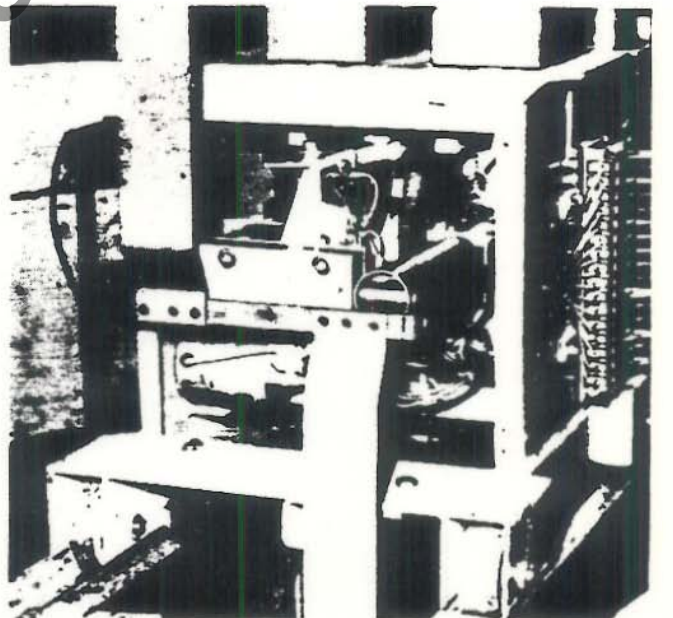

340066

SPRING BLOCKING DEVICE IN PLACE READY FOR CLOSING SPRING RELEASE.

Fig. 13. Maintenance Close Spring Blocking Device Insertion

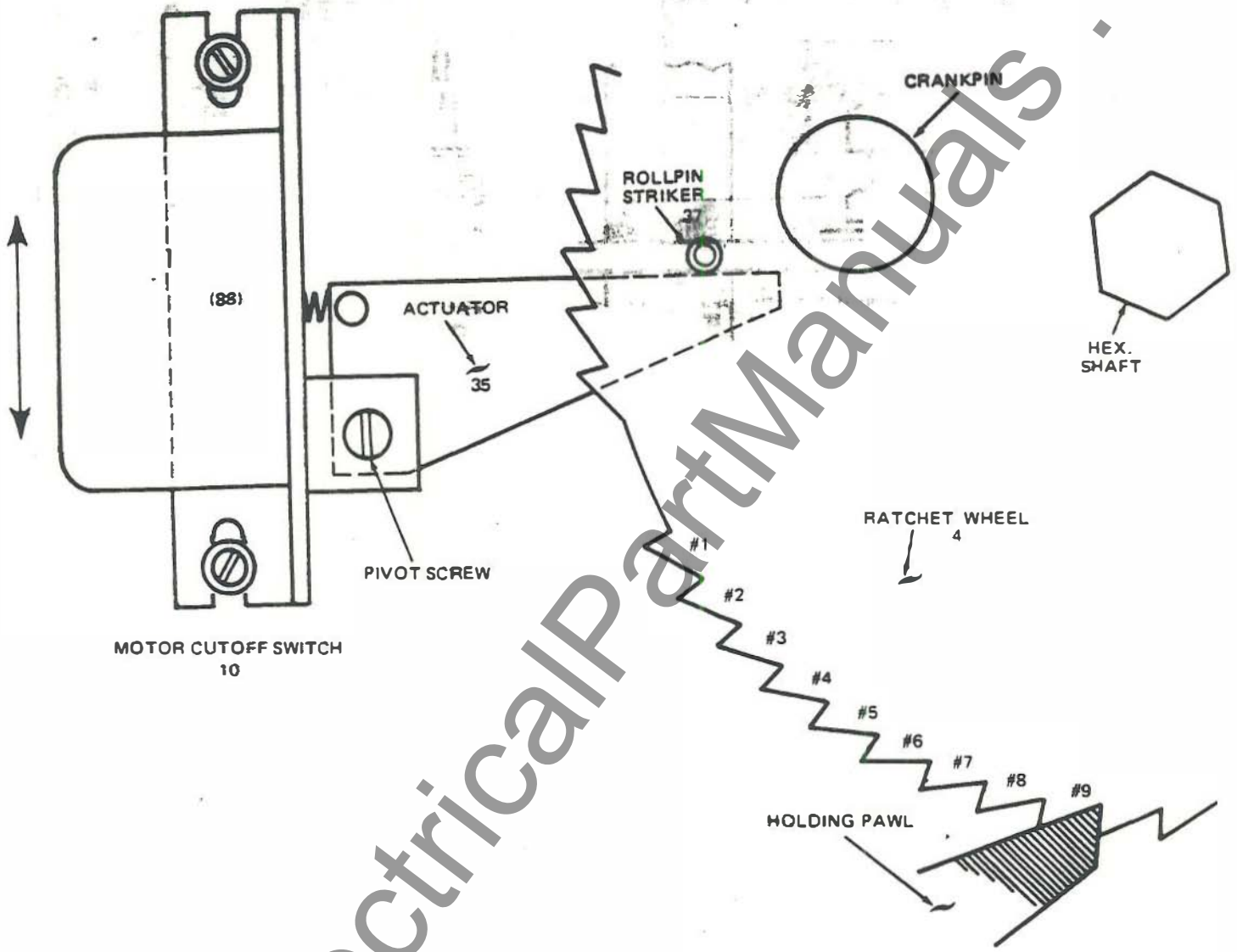

Fig. 14 — Motor Cutoff Switch

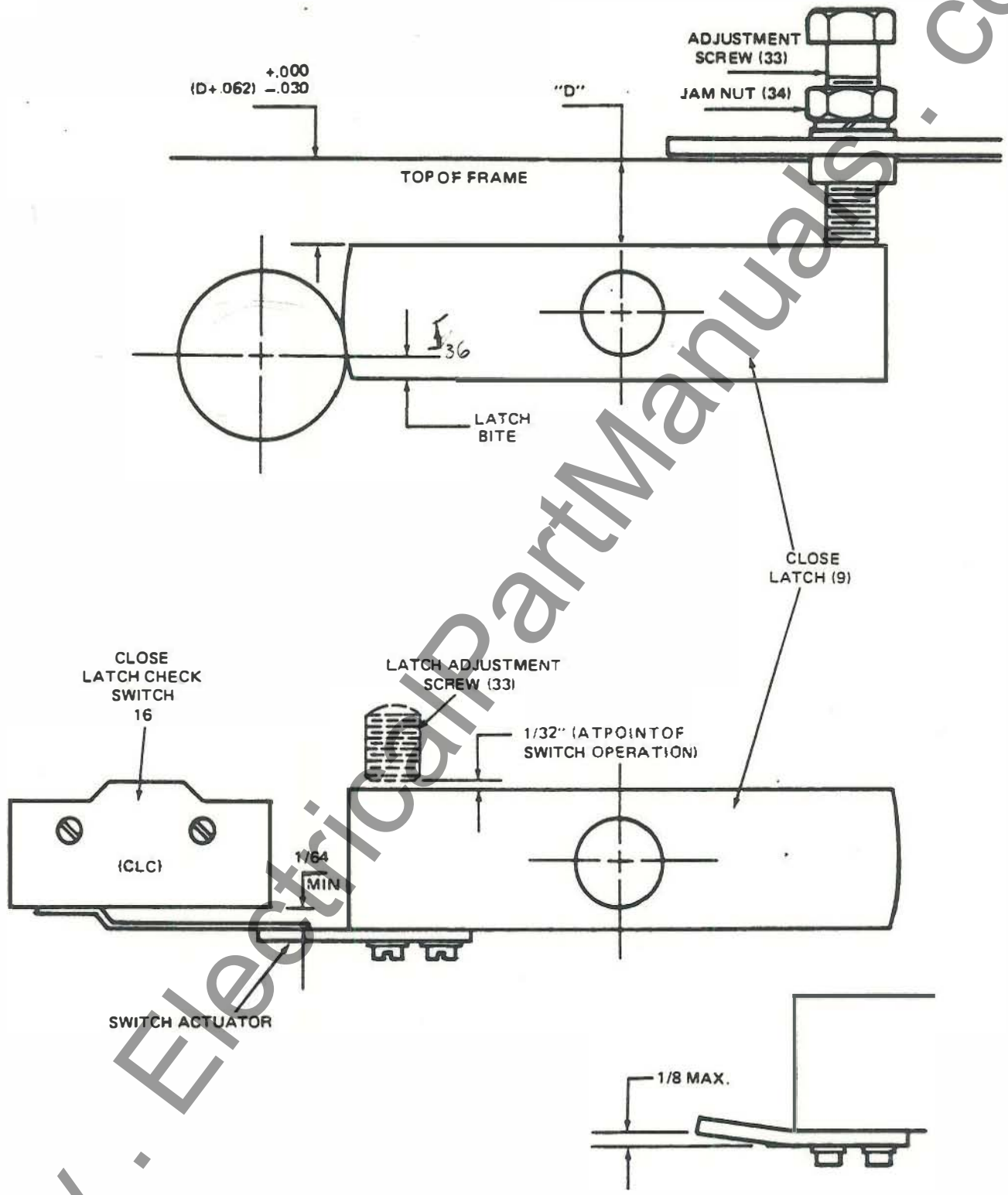

Fig. 15 - Close Latch Bite and Check Switch Adjustments

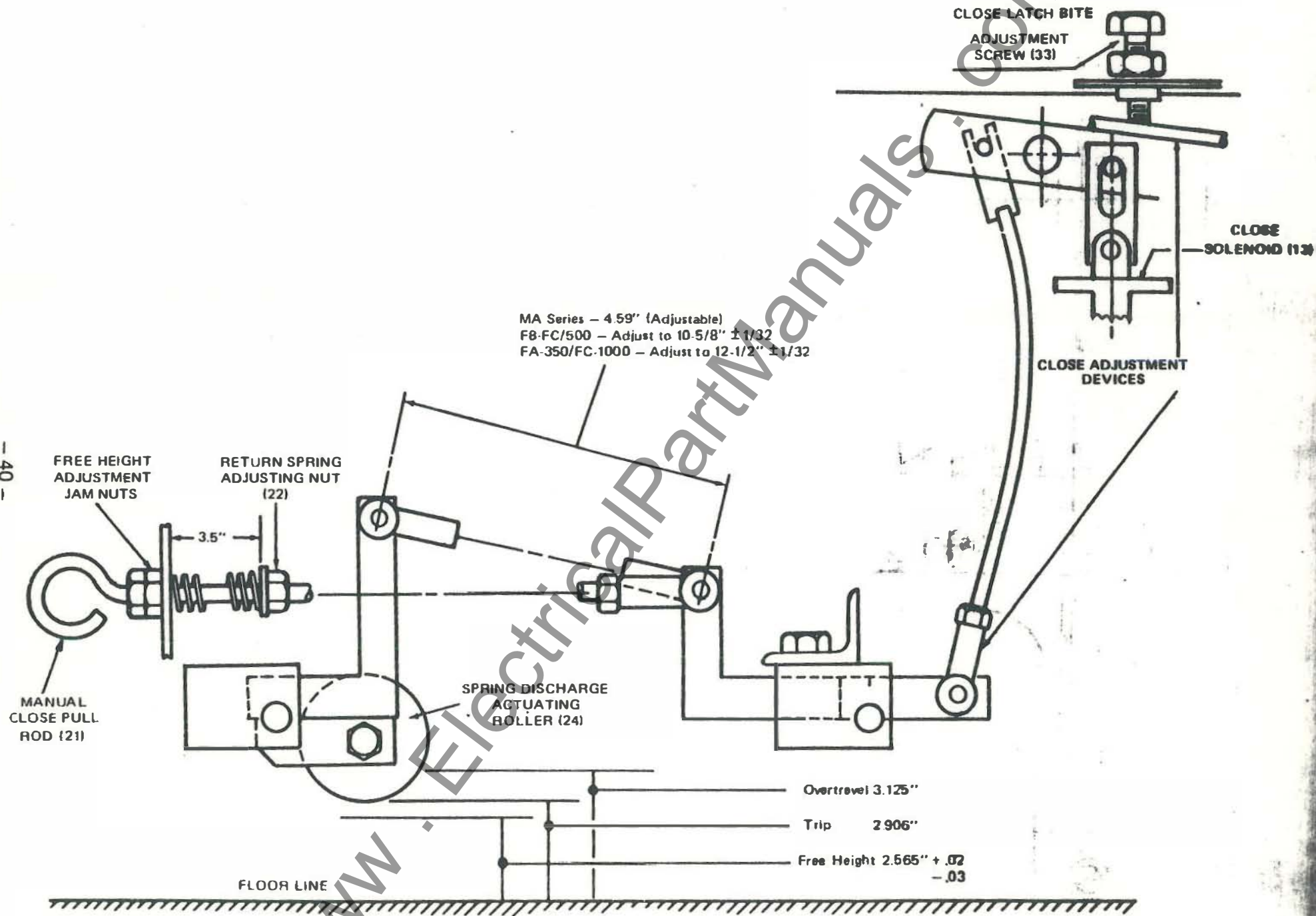

Fig. 16 - Closing Spring Discharge Mechanism

www.ElectricalPartManuals.com

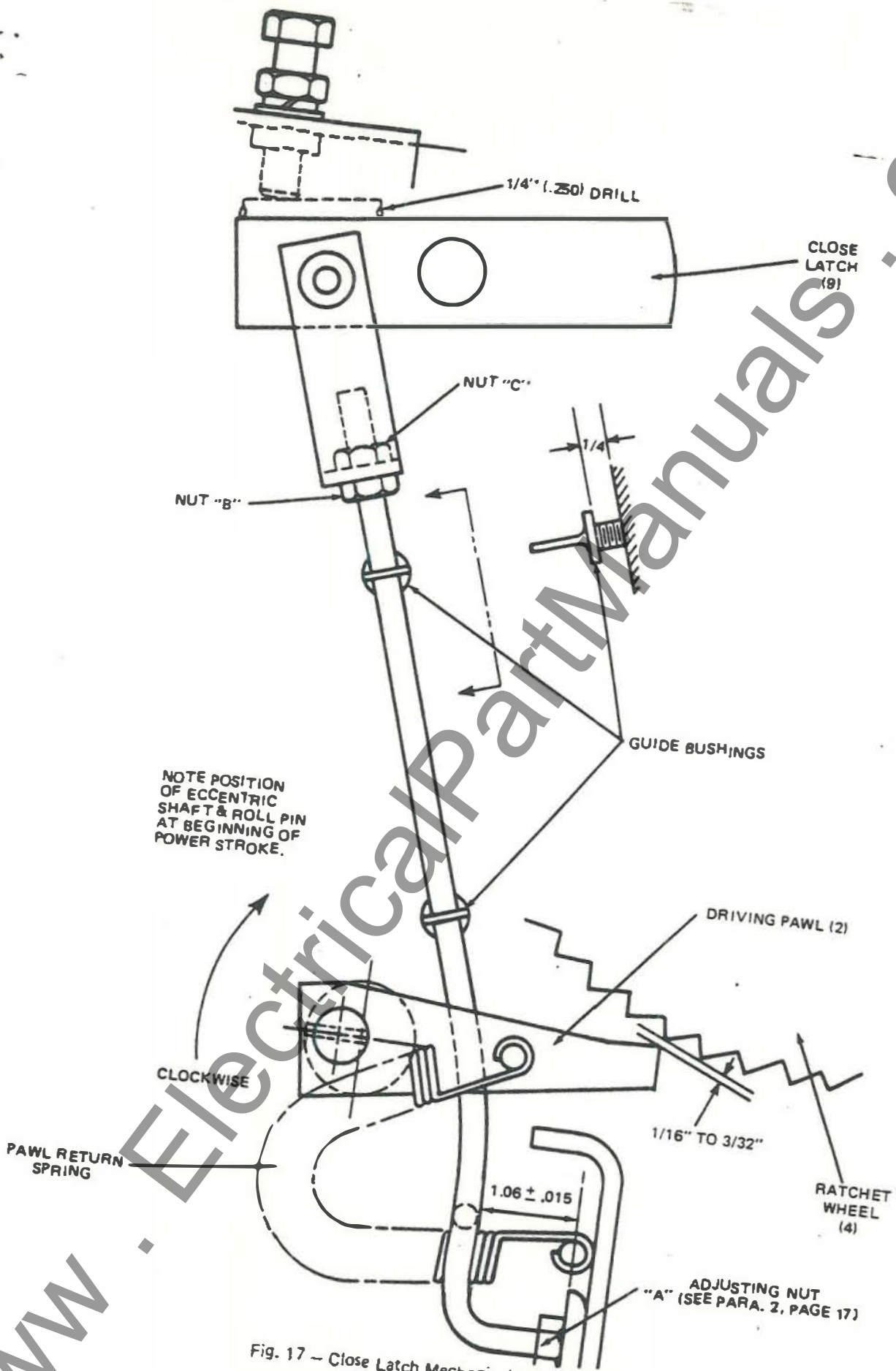

Fig. 17 -- Close Latch Mechanical Interlock

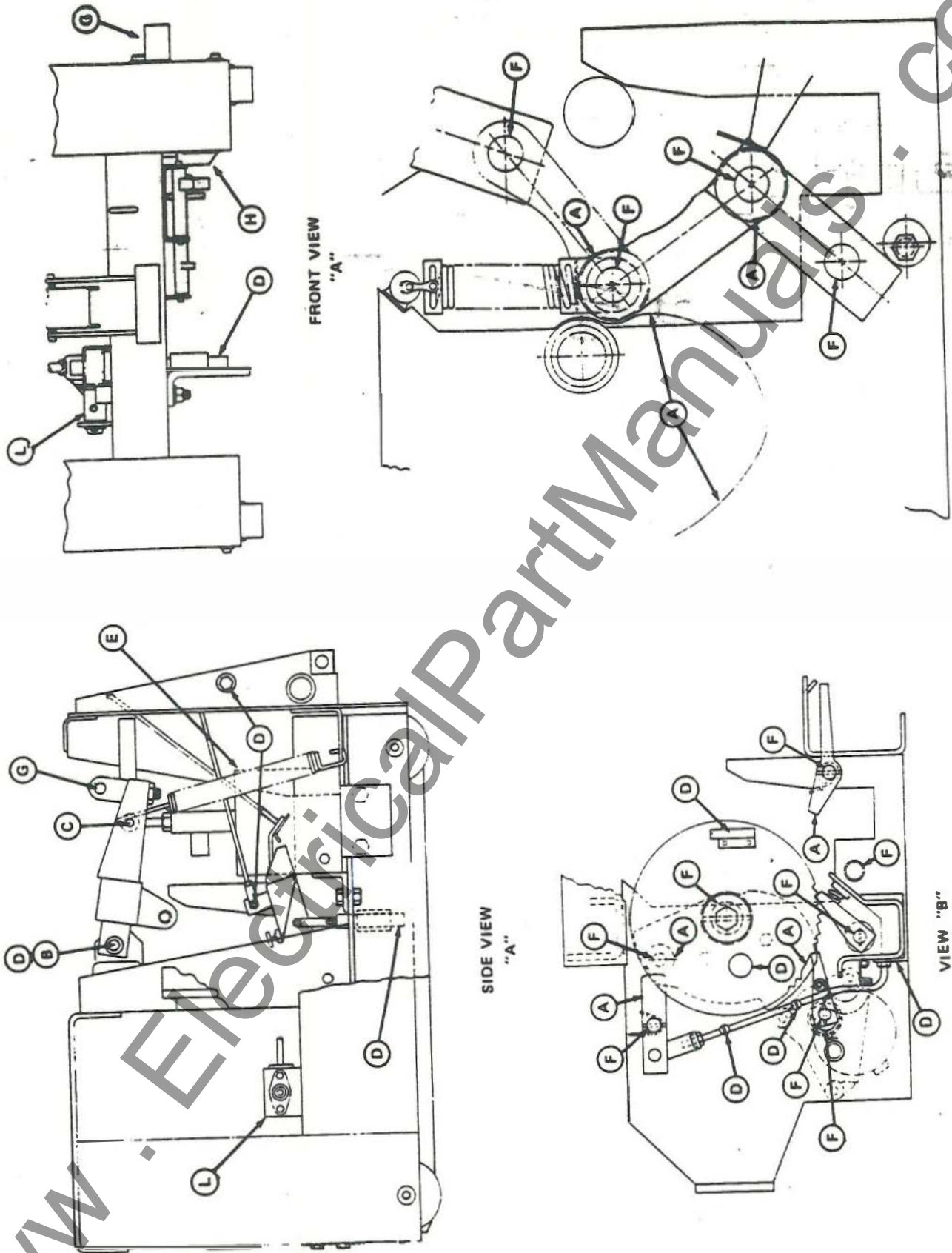

Fig. 18 -- Lubrication Points On Frame And Operator (View A) Drive Assembly (View B) And Linkage Assembly (View C).

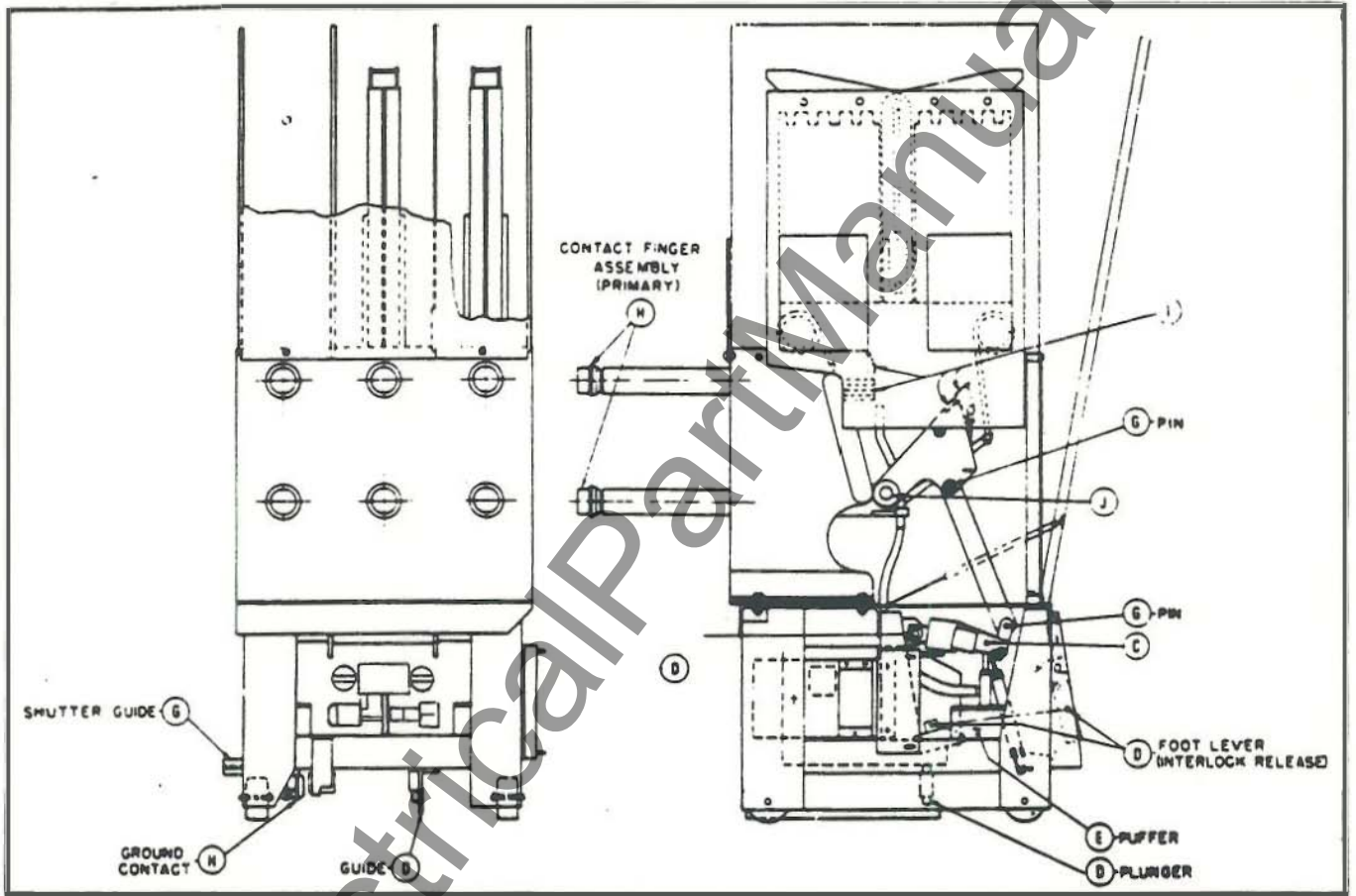

Fig. 19 Lubrication Points on Breaker

LUBRI- CATION KEY	PART DESCRIPTION	SUGGESTED LUBRICATION AT EVERY 2000 OPERATIONS OR ONCE EVERY YEAR.	ALTERNATE LUBRICATION (RE- QUIRES DISASSEMBLY) RECOM- MENDED AFTER EVERY 10,000 OPER.
A	GROUND SURFACES SUCH AS LATCHES, ROLLERS, PROPS, ETC.	WIPE CLEAN AND SPRAY WITH "MOLYCOTE 557" 15-171-270-001.	WASH CLEAN AND SPRAY WITH "MOLYCOTE 557" 15-171-270-001.
B	NYLON SLEEVE BEARINGS, SUCH AS: THE CONTACT ARM HINGE PIN.	NO LUBRICATION REQUIRED.	NO LUBRICATION REQUIRED.
C	SLEEVE BEARINGS AND PIVOT PINS, ROTATING PARTS SUCH AS DRIVE PINION, DRIVING CRANKS, SLIDE AND PIVOT PINS.	LIGHT APPLICATION OF "MOLYCOTE PENELUBE" 15-171-270-002.	REMOVE PINS OR BEARINGS. CLEAN PER INSTRUCTIONS AND APPLY "BEACON P-290" 00-337-131-001.
D	SLIDING SURFACES.	LIGHT APPLICATION OF "MOLYCOTE 557".	WIPE CLEAN AND APPLY "MOLY- COTE 557" LIBERALLY.
E	AIR PUFFER CYLINDERS.	WIPE CLEAN AND APPLY TRANSFORMER OIL # 3 TO FELT. 15-171-729-001	WASH CLEAN AND WET FELT RING IN TRANSFORMER OIL # 3.
F	ROLLER AND NEEDLE BEARINGS.	NO LUBRICATION REQUIRED.	CLEAN PER INSTRUCTIONS AND REPACK WITH "BEACON P-325".
G	DRY PIVOT POINTS.	NO LUBRICATION REQUIRED.	NO LUBRICATION REQUIRED.
H	PRIMARY AND SECONDARY DISCONNECT FINGERS, ARCING CONTACT HINGE, GROUNDING CONTACT AND AUX. SWITCH CONTACTS.	WIPE CLEAN AND APPLY A FILM OF ALLIS-CHALMERS CONTACT LUBRICANT 15-171-370-002.	
I	ARCING CONTACTS.	DO NOT LUBRICATE.	DO NOT LUBRICATE.
J	DISCONNECT ARM HINGE JOINT SILVER WASHER BETWEEN BUSHING AND THE CONTACT ARM.	WIPE CLEAN AND APPLY A FILM OF ALLIS-CHALMERS CONTACT LUBRICANT 15-171-370-002.	
K	CHARGING SPRINGS & SPRING RETAINERS	NO LUBRICATION REQUIRED	WIPE CLEAN AND COAT WITH OF "BEACON P-325."
L	MANUAL CHARGING BEVEL GEAR TRAIN, FB & FC SERIES ONLY.	REMOVE SNAP ON COVER & COAT TEETH LIGHTLY WITH "BEACON P-325."	REMOVE SNAP ON COVER & COAT TEETH LIGHTLY WITH "BEACON P-325." 15-337-131-001
M	ARCING CONTACT HINGE ASSEMBLY.	WIPE CLEAN AND APPLY A FILM OF ALLIS-CHALMERS CONTACT LUBRICANT 15-171-370-002.	

Fig. 20 Lubrication Chart

INDEX	PAGE	PAGE	
INTRODUCTION	1	Barrier Stacks	11
Warranty	1	Contact Pressure of Hinge Joint	12
Receiving	1	Arcing Contact Hinge Joint	12
Storage	1	Contact Alignment and Replacement	12
Circuit Breaker Preparation	1	Auxiliary Switch	14
CIRCUIT BREAKER DESCRIPTION	3	Interior Plunger	14
Arc Interruption	3	Trip Latch Adjustments	14
Operator	3	Trip Latch Check Sensor Adjustments	15
Stored Energy Operator	3	Manual Charging of Closing Springs	15
Reclosing Control	4	Maintenance Slow Close	15
Auxiliary Equipment	4	Removal of Spring Blocking Device	16
Auxiliary Switch	4	Removal of Closing Springs	16
Capacitor Trip Device	4	Motor Cutoff Switch	16
Trip Solenoid	4	Motor Cutoff Switch Adjustment	16
Arc Chute Assembly	5	Close Latch Bite Adjustment	17
CIRCUIT BREAKER OPERATION	5	Close Latch Check Switch Adjustment	17
STORED ENERGY OPERATOR DESCRIPTION OF OPERATION	6	Free Height Adjustment	17
Spring Charging Cycle	6	Trip Adjustment	17
Reclosing Control	6	Overtravel	17
Breaker Closing Cycle	7	Close Latch Mechanical Interlock	17
Spring Recharge After Closing	7	MAINTENANCE AND TESTING	19
Tripping Cycle	7	General	19
Stored Energy Operator -- Components Nomenclature	8	"As Found" Tests	19
Electrical Control	9	Periodic Inspection and Maintenance	19
Spring Charging	9	Contacts	19
Closing Circuit	9	Disconnect Arm Hinge Joint	20
Close Latch -- Mechanical and Electrical Interlocks	9	Arc Chutes	20
ADJUSTMENTS	11	Mechanism -- Stored Energy Operator	21
Circuit Breaker Timing	11	Lubrication	21
Phase Barrier Assembly	11	Air Puffers	22
Tilting Arc Chutes	11	"As Left" Tests	22
ILLUSTRATIONS			
Fig. 1 Circuit Breaker Handling Instructions	24	Fig. 11 Trip Latch Clearance Adjustment	35
Fig. 2 Typical Circuit Breaker Assemblies	25	Fig. 12 Trip Latch Bite and Check Switch Adjustments	36
Fig. 2A Arc Chute Support in Position	26	Fig. 13 Maintenance Close Spring Blocking Device Insertion	37
Fig. 3 515-2 Operator Left Hand View	27	Fig. 14 Motor Cutoff Switch	38
Fig. 4 Breaker Contacts	28	Fig. 15 Close Latch Bite and Check Switch Adjustments	39
Fig. 5 Type Q-10 Auxiliary Switch	29	Fig. 16 Closing Spring Discharge Mechanism	40
Fig. 6 Arc Chutes	30	Fig. 17 Close Latch Mechanical Interlock	41
Fig. 7 515-2 Operator Right Hand View	31	Fig. 18 Frame and Operator, Drive Assembly and Linkage Assembly Lubrication	42
Fig. 8 515-2 Operator Front View	32	Fig. 19 Lubrication Points on Breaker	43
Fig. 9 Control Scheme for Stored Energy Operator	33	Fig. 20 Lubrication Chart	44
Fig. 10 Stud and Support Assembly	34		

SIEMENS-ALLIS

www.ElectricalPartManuals.com

Switchgear Division
P. O. Box 14505
West Allis, Wisconsin 53214
414 475-3600